



Lenovo System x3250 M6 Installation and Service Guide



Machine Types: 3633 and 3943

Note: Before using this information and the product it supports, ensure that you read the *Warranty Information*, the *Safety Information*, and *Environmental Notices and User Guide* on the Lenovo® *Documentation CD* that comes with your product.

First Edition (April 2016)

© Copyright Lenovo 2016.

LIMITED AND RESTRICTED RIGHTS NOTICE: If data or software is delivered pursuant to a General Services Administration "GSA" contract, use, reproduction, or disclosure is subject to restrictions set forth in Contract No. GS-35F-05925.

Contents

Safety	v
Guidelines for trained service technicians	vi
Inspecting for unsafe conditions	vi
Guidelines for servicing electrical equipment	vii
Safety statements	viii

Chapter 1. Documentation and notice types. **1**

The Lenovo <i>System x Documentation</i> CD	1
System requirements	1
Documentation Browser	1
Related documentation	2
Notices in this document	2

Chapter 2. About the Lenovo System x3250 M6 server. **5**

Server features and specifications	6
What your server offers	9
Reliability, Availability, and Serviceability	12
Turning on or turning off the server	13
Turning on the server	13
Turning off the server	13

Chapter 3. Component locations **15**

Front view	15
Rear view.	17
Operator information panel	18
Server components.	19
System-board connectors	21
System-board switches and jumpers	22
System-board LEDs	24

Chapter 4. Configuration information **25**

Updating the firmware.	25
Configuring the server.	26
Using the ServerGuide Setup and Installation CD	27
Using the Setup Utility program	28
Using the Boot Manager program	34
Starting the backup server firmware	34
UpdateXpress System Pack Installer	34
Changing the Power Policy option to the default settings after loading UEFI defaults.	34
Using the Integrated Management Module II (IMM2)	35
Using the remote presence and blue-screen capture features	36

Using the embedded hypervisor	37
Ethernet controller information.	38
Enabling Features on Demand Ethernet and Demand RAID software	38
Accessing RAID configuration utility	39
Lenovo ToolsCenter Suite CLI program	39
Using Lenovo XClarity Administrator	39
Updating the Universal Unique Identifier (UUID)	40
Updating the DMI/SMBIOS data	42
Configuring onboard SATA software RAID	44
Enabling the onboard SATA RAID functionality	44
Creating RAID volumes	44
Deleting RAID volumes	45
Marking disks as spare	45

Chapter 5. Troubleshooting **47**

Start here.	47
Diagnosing a problem	47
Opening an online service request	49
Service bulletins	49
Checkout procedure	50
Precautions before performing the checkout procedure.	50
Performing the checkout procedure	50
Diagnostic tools	51
Light path diagnostics	53
Error LEDs	53
Power-supply LEDs	54
System pulse LEDs	55
Event logs.	56
POST	58
Dynamic System Analysis	58
Automated service request (call home)	60
Electronic Service Agent	60
Error messages	60
Troubleshooting by symptom	61
General problems.	61
Optical drive problems.	62
Hard disk drive problems.	62
Hypervisor problems	64
Intermittent problems	64
Keyboard, mouse, or USB-device problems	65
Memory problems	65
Monitor problems.	66
Network connection problems.	68

Optional-device problems	68
Operating system boot problem	68
Power problems	69
Serial port problems.	70
ServerGuide problems.	70
Software problems	71
USB connector problems.	71
Solving power problems	71
Solving Ethernet controller problems	72
Solving undetermined problems	72
Problem determination tips.	73
Recovering the server firmware (UEFI update failure)	74
In-band manual recovery method	75
In-band automated boot recovery method	75
Out-of-band method	76
Automated boot recovery (ABR)	76
Nx-boot failure.	76

Chapter 6. Parts listing, Lenovo System x3250 M6 77

Replaceable server components.	77
Structural parts.	83
Power cords	83

Chapter 7. Removing and installing server components 87

Before removing or installing server components	87
System reliability guidelines.	87
Working inside the server with the power on	87
Handling static-sensitive devices	88
Removing and installing server components	88
Removing and installing structural parts	88
Removing and installing Tier 1 CRUs	96
Removing and installing Tier 2 CRUs	145
Internal cable routing	158
Completing the parts replacement	172
Instructions for Business Partners	173
Sending DSA data to Lenovo	173
Returning a device or component	174

Appendix A. Integrated Management Module II (IMM2) error messages . 175

List of IMM events	176
IMM Events that automatically notify Support	487

Appendix B. UEFI (POST) error codes 491

List of UEFI events	491
-------------------------------	-----

Appendix C. DSA diagnostic test results 503

DSA Broadcom network test results	503
Test results for the DSA Broadcom network test	503
DSA Brocade test results	513
Test results for the DSA Brocade test	513
DSA checkpoint panel test results	522
Test results for the DSA checkpoint panel test	522
DSA CPU stress test results	524
Test results for the DSA CPU stress test	524
DSA Emulex adapter test results.	527
Test results for the DSA Emulex adapter test	527
DSA EXA port ping test results	531
Test results for the DSA EXA port ping test	531
DSA hard drive test results	534
Test results for the DSA hard drive test	534
DSA Intel network test results.	535
Test results for the DSA Intel network test	535
DSA LSI hard drive test results	542
Test results for the DSA LSI hard drive test	542
DSA Mellanox adapter test results	543
Test results for the DSA Mellanox adapter test	544
DSA memory isolation test results	546
Test results for the DSA memory isolation test	546
DSA memory stress test results	624
Test results for the DSA memory stress test	624
DSA Nvidia GPU test results	627
Test results for the DSA Nvidia GPU test.	628
DSA optical drive test results	634
Test results for the DSA optical drive test	634
DSA system management test results	639
Test results for the DSA system management test	639
DSA tape drive test results	655
Test results for the DSA tape drive test	655

Appendix D. Getting help and technical assistance 661

Before you call.	661
Using the documentation	662
Getting help and information from the World Wide Web	662
How to send DSA data	662
Creating a personalized support web page	662
Software service and support	663
Hardware service and support	663
Taiwan product service	663

Appendix E. Notices	665
Trademarks	666
Important notes	666
Recycling information	667
Particulate contamination	667
Telecommunication regulatory statement	667
Electronic emission notices.	668
Federal Communications Commission (FCC) statement	668
Industry Canada Class A emission compliance statement	668
Avis de conformité à la réglementation d'Industrie Canada	668
Australia and New Zealand Class A statement	668
European Union EMC Directive conformance statement	668

Germany Class A statement	669
Japan VCCI Class A statement	669
Japanese statement for ac power consumption for JEITA harmonics guideline	670
Japanese statement of compliance for products less than or equal to 20 A per phase for JEITA harmonics guideline	670
Korea Communications Commission (KCC) statement	670
Russia Electromagnetic Interference (EMI) Class A statement	670
People's Republic of China Class A electronic emission statement	670
Taiwan Class A compliance statement	671
Taiwan BSMI RoHS declaration	672

Index.	673
-----------------------	------------

Safety

Before installing this product, read the Safety Information.

قبل تركيب هذا المنتج، يجب قراءة الملاحظات الأمنية

Antes de instalar este produto, leia as Informações de Segurança.

在安裝本產品之前，請仔細閱讀 **Safety Information**
(安全信息)。

安裝本產品之前，請先閱讀「安全資訊」。

Prije instalacije ovog produkta obavezno pročitajte Sigurnosne Upute.

Před instalací tohoto produktu si přečtěte příručku bezpečnostních instrukcí.

Læs sikkerhedsforskrifterne, før du installerer dette produkt.

Lees voordat u dit product installeert eerst de veiligheidsvoorschriften.

Ennen kuin asennat tämän tuotteen, lue turvaohjeet kohdasta Safety Information.

Avant d'installer ce produit, lisez les consignes de sécurité.

Vor der Installation dieses Produkts die Sicherheitshinweise lesen.

Πριν εγκαταστήσετε το προϊόν αυτό, διαβάστε τις πληροφορίες ασφάλειας
(safety information).

לפני שתתקינו מוצר זה, קראו את הוראות הבטיחות.

A termék telepítése előtt olvassa el a Biztonsági előírásokat!

Prima di installare questo prodotto, leggere le Informazioni sulla Sicurezza.

製品の設置の前に、安全情報をお読みください。

본 제품을 설치하기 전에 안전 정보를 읽으십시오.

Пред да се инсталира овој продукт, прочитајте информацијата за безбедност.

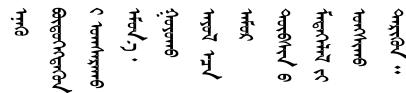

Les sikkerhetsinformasjonen (Safety Information) før du installerer dette produktet.

Przed zainstalowaniem tego produktu, należy zapoznać się
z książką "Informacje dotyczące bezpieczeństwa" (Safety Information).

Antes de instalar este produto, leia as Informações sobre Segurança.

Перед установкой продукта прочтите инструкции по технике безопасности.

Pred inštaláciou tohto zariadenia si pečítajte Bezpečnostné predpisy.

Pred namestitvijo tega proizvoda preberite Varnostne informacije.

Antes de instalar este producto, lea la información de seguridad.

Läs säkerhetsinformationen innan du installerar den här produkten.

ཐོན་རྒྱུ་འདི་བདེ་སྤྱོད་མ་བྱས་གོང་། རྒྱུ་མི་ཡིད་གཟབ་
བྱ་འདྲ་མིན་ཡོད་པའི་འོད་ཟེར་བལྟ་དགོས།

Bu ürünü kurmadan önce güvenlik bilgilerini okuyun.

مەزكۇر مەھسۇلاتنى ئورنىتىشتىن بۇرۇن بىخەتەرلىك ئۇچۇرلىرىنى ئوقۇپ چىقىڭ.

Youq mwngz yungh canjbinj neix gaxgonq, itdingh aeu doeg aen
canjbinj soengq cungj vahgangj ancien siusik.

Guidelines for trained service technicians

This section contains information for trained service technicians.

Inspecting for unsafe conditions

Use this information to help you identify potential unsafe conditions in a device that you are working on.

Each device, as it was designed and manufactured, has required safety items to protect users and service technicians from injury. The information in this section addresses only those items. Use good judgment to identify potential unsafe conditions that might be caused by unsupported alterations or attachment of unsupported features or optional devices that are not addressed in this section. If you identify an unsafe condition, you must determine how serious the hazard is and whether you must correct the problem before you work on the product.

Consider the following conditions and the safety hazards that they present:

- Electrical hazards, especially primary power. Primary voltage on the frame can cause serious or fatal electrical shock.
- Explosive hazards, such as a damaged CRT face or a bulging capacitor.
- Mechanical hazards, such as loose or missing hardware.

To inspect the product for potential unsafe conditions, complete the following steps:

1. Make sure that the power is off and the power cords are disconnected.
2. Make sure that the exterior cover is not damaged, loose, or broken, and observe any sharp edges.
3. Check the power cords:
 - Make sure that the third-wire ground connector is in good condition. Use a meter to measure third-wire ground continuity for 0.1 ohm or less between the external ground pin and the frame ground.
 - Make sure that the power cords are the correct type.
 - Make sure that the insulation is not frayed or worn.
4. Remove the cover.

5. Check for any obvious unsupported alterations. Use good judgment as to the safety of any unsupported alterations.
6. Check inside the system for any obvious unsafe conditions, such as metal filings, contamination, water or other liquid, or signs of fire or smoke damage.
7. Check for worn, frayed, or pinched cables.
8. Make sure that the power-supply cover fasteners (screws or rivets) have not been removed or tampered with.

Guidelines for servicing electrical equipment

Observe these guidelines when you service electrical equipment.

- Check the area for electrical hazards such as moist floors, nongrounded power extension cords, and missing safety grounds.
- Use only approved tools and test equipment. Some hand tools have handles that are covered with a soft material that does not provide insulation from live electrical current.
- Regularly inspect and maintain your electrical hand tools for safe operational condition. Do not use worn or broken tools or testers.
- Do not touch the reflective surface of a dental mirror to a live electrical circuit. The surface is conductive and can cause personal injury or equipment damage if it touches a live electrical circuit.
- Some rubber floor mats contain small conductive fibers to decrease electrostatic discharge. Do not use this type of mat to protect yourself from electrical shock.
- Do not work alone under hazardous conditions or near equipment that has hazardous voltages.
- Locate the emergency power-off (EPO) switch, disconnecting switch, or electrical outlet so that you can turn off the power quickly in the event of an electrical accident.
- Disconnect all power before you perform a mechanical inspection, work near power supplies, or remove or install main units.
- Before you work on the equipment, disconnect the power cord. If you cannot disconnect the power cord, have the customer power-off the wall box that supplies power to the equipment and lock the wall box in the off position.
- Never assume that power has been disconnected from a circuit. Check it to make sure that it has been disconnected.
- If you have to work on equipment that has exposed electrical circuits, observe the following precautions:
 - Make sure that another person who is familiar with the power-off controls is near you and is available to turn off the power if necessary.
 - When you work with powered-on electrical equipment, use only one hand. Keep the other hand in your pocket or behind your back to avoid creating a complete circuit that could cause an electrical shock.
 - When you use a tester, set the controls correctly and use the approved probe leads and accessories for that tester.
 - Stand on a suitable rubber mat to insulate you from grounds such as metal floor strips and equipment frames.
- Use extreme care when you measure high voltages.
- To ensure proper grounding of components such as power supplies, pumps, blowers, fans, and motor generators, do not service these components outside of their normal operating locations.
- If an electrical accident occurs, use caution, turn off the power, and send another person to get medical aid.

Safety statements

These statements provide the caution and danger information that is used in this documentation.

Important: Each caution and danger statement in this documentation is labeled with a number. This number is used to cross reference an English-language caution or danger statement with translated versions of the caution or danger statement in the *Safety Information* document.

For example, if a caution statement is labeled Statement 1, translations for that caution statement are in the *Safety Information* document under Statement 1.

Be sure to read all caution and danger statements in this documentation before you perform the procedures. Read any additional safety information that comes with your system or optional device before you install the device.

Statement 1



Electrical current from power, telephone, and communication cables is hazardous.

To avoid a shock hazard:

- **Do not connect or disconnect any cables or perform installation, maintenance, or reconfiguration of this product during an electrical storm.**
- **Connect all power cords to a properly wired and grounded electrical outlet.**
- **Connect to properly wired outlets any equipment that will be attached to this product.**
- **When possible, use one hand only to connect or disconnect signal cables.**
- **Never turn on any equipment when there is evidence of fire, water, or structural damage.**
- **Disconnect the attached power cords, telecommunications systems, networks, and modems before you open the device covers, unless instructed otherwise in the installation and configuration procedures.**
- **Connect and disconnect cables as described in the following table when installing, moving, or opening covers on this product or attached devices.**

To Connect:

1. Turn everything OFF.
2. First, attach all cables to devices.
3. Attach signal cables to connectors.
4. Attach power cords to outlet.
5. Turn device ON.

To Disconnect:

1. Turn everything OFF.
2. First, remove power cords from outlet.
3. Remove signal cables from connectors.
4. Remove all cables from devices.

Statement 2



CAUTION:

When replacing the lithium battery, use only Part Number 33F8354 or an equivalent type battery recommended by the manufacturer. If your system has a module containing a lithium battery, replace it only with the same module type made by the same manufacturer. The battery contains lithium and can explode if not properly used, handled, or disposed of.

Do not:

- Throw or immerse into water
- Heat to more than 100°C (212°F)
- Repair or disassemble

Dispose of the battery as required by local ordinances or regulations.

Statement 3



CAUTION:

When laser products (such as CD-ROMs, DVD drives, fiber optic devices, or transmitters) are installed, note the following:

- Do not remove the covers. Removing the covers of the laser product could result in exposure to hazardous laser radiation. There are no serviceable parts inside the device.
- Use of controls or adjustments or performance of procedures other than those specified herein might result in hazardous radiation exposure.



DANGER

Some laser products contain an embedded Class 3A or Class 3B laser diode. Note the following.

Laser radiation when open. Do not stare into the beam, do not view directly with optical instruments, and avoid direct exposure to the beam.

Class 1 Laser Product

Laser Klasse 1

Laser Klass 1

Luokan 1 Laserlaite

Appareil À Laser de Classe 1

Statement 4



CAUTION:
Use safe practices when lifting.

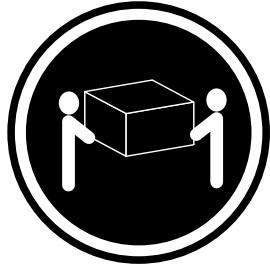

≥ 18 kg (39.7 lb)

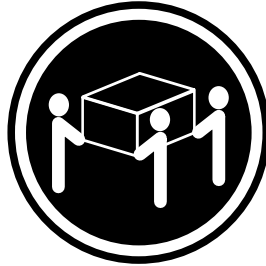

≥ 32 kg (70.5 lb)

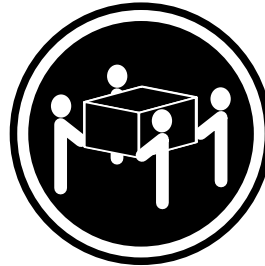

≥ 55 kg (121.2 lb)

Statement 5



CAUTION:
The power control button on the device and the power switch on the power supply do not turn off the electrical current supplied to the device. The device also might have more than one power cord. To remove all electrical current from the device, ensure that all power cords are disconnected from the power source.



Statement 6



CAUTION:
If you install a strain-relief bracket option over the end of the power cord that is connected to the device, you must connect the other end of the power cord to an easily accessible power source.

Statement 8



CAUTION:

Never remove the cover on a power supply or any part that has the following label attached.

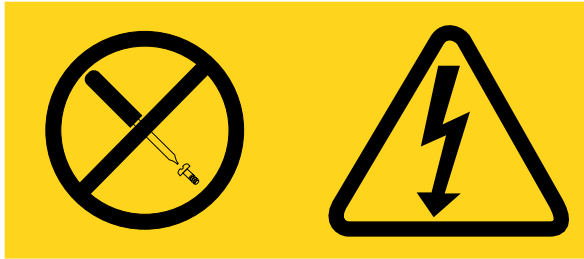

Hazardous voltage, current, and energy levels are present inside any component that has this label attached. There are no serviceable parts inside these components. If you suspect a problem with one of these parts, contact a service technician.

Statement 12



CAUTION:

The following label indicates a hot surface nearby.



Statement 26



CAUTION:

Do not place any object on top of rack-mounted devices.

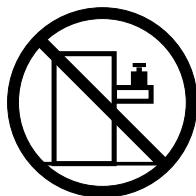

Statement 27



CAUTION:

Hazardous moving parts are nearby.



Rack Safety Information, Statement 2



 **DANGER**

- **Always lower the leveling pads on the rack cabinet.**
- **Always install stabilizer brackets on the rack cabinet.**
- **Always install servers and optional devices starting from the bottom of the rack cabinet.**
- **Always install the heaviest devices in the bottom of the rack cabinet.**

Chapter 1. Documentation and notice types

This topic provides general descriptions of the various documentation and notices for your server and instructions on how to obtain all the documentation.

The Lenovo System x Documentation CD

The Lenovo *System x Documentation* CD contains documentation for the server in Portable Document Format (PDF) and includes the Lenovo Documentation Browser to help you find information quickly.

System requirements

The Lenovo *System x Documentation* CD has the following system requirements:

- Microprocessor: at least 100 MHz
- Random access memory (RAM): at least 32 MB
- Operating system: Microsoft® Windows® or Red Hat® Enterprise Linux®
- PDF reader: Adobe Acrobat Reader DC or Xpdf

Documentation Browser

The Documentation Browser enables you to browse the contents of the CD by viewing document descriptions and reading the documents with a PDF reader (Adobe Acrobat Reader DC or Xpdf).

The Documentation Browser automatically detects the regional settings in use in your server and displays the documents in the language for that region (if available). If a document is not available in the language for that region, the English-language version is displayed.

Use one of the following procedures to start the Documentation Browser:

- If Autostart is enabled, insert the documentation CD into the CD or DVD drive. The Documentation Browser starts automatically.
- If Autostart is disabled or is not enabled for all users, do one of the following:
 - For Windows: insert the CD into the CD or DVD drive and click **Start → Run**. In the **Open** field, type:
e:\win32.bat
where e is the drive letter of the CD or DVD drive, and click **OK**.
 - For Red Hat Enterprise Linux: insert the CD into the CD or DVD drive; then, run the following command from the /mnt/cdrom directory:
sh runlinux.sh

After the Documentation Browser starts, select your server from the **Product** menu. The **Available Topics** list displays all the documents for the server. Some documents might be in folders. A plus sign (+) indicates each folder or document that has additional documents under it. Click the plus sign to display the additional documents.

After you select a document, a description of the document is displayed under **Topic Description**. To select more than one document, press and hold the Ctrl key while you select the documents. Click **View** to open the selected document or documents in Acrobat Reader or Xpdf. If you selected more than one document, all the selected documents are opened in Acrobat Reader or Xpdf.

To search all the documents, type a word or word string in the **Search** field and click **Search**. The documents in which the word or word string appears are listed in order of the most occurrences. Click a

document to view it, and press Ctrl+F to use the Acrobat search function, or press Alt+F to use the Xpdf search function within the document.

Click **Help** for detailed information about using the Documentation Browser.

Related documentation

Refer to the documentation in this topic to help you use and maintain your server.

<i>Installation and Service Guide</i>	This document contains general information about the server including how to set up and cable the server, how to install supported optional devices, how to configure the server, and information to help you solve problems yourself and information for service technicians. You can view the document on the Lenovo Web site.
<i>Important Notices (printed)</i>	This document comes with the server. It contains information about the safety, environmental, and electronic emission notices for your Lenovo product.
<i>Rack Installation Instructions (printed)</i>	This document contains instructions for installing the server in a rack and comes with the rack kit.
<i>Safety, Support, and Warranty Information (printed)</i>	This document comes with the server. It contains warranty terms and a pointer to the Lenovo Statement of Limited Warranty on the Lenovo Web site.

The following documentation is in PDF on the Lenovo *Documentation CD*.

<i>Environmental Notices and User Guide</i>	It contains translated environmental notices.
<i>Lenovo License Agreement for Machine Code</i>	It provides translated versions of the <i>Lenovo License Agreement for Machine Code</i> for your product.
<i>Safety Information</i>	It contains translated caution and danger statements. Each caution and danger statement that appears in the documentation has a number that you can use to locate the corresponding statement in your language in the <i>Safety Information</i> document.
<i>Rack Safety Information</i>	This multilingual document provides translated versions of the caution and danger statements that appear in the rack documentation. Each caution and danger statement has an assigned number, which you can use to locate the corresponding statement in your native language.
<i>Safety Information Labels</i>	This document provides the Simplified Chinese, Mongolian, Tibetan, Uygur, and Zhuang translated versions of the product safety labels.
<i>Licenses and Attributions Documents</i>	It provides the open source notices.

Depending on the server model, additional documentation might be included on the Lenovo *System x Documentation CD*.

The System x and BladeCenter Tools Center is an online information center that contains information about tools for updating, managing, and deploying firmware, device drivers, and operating systems. The System x and BladeCenter Tools Center is at <https://support.lenovo.com/us/en/documents/LNVO-CENTER>.

Notices in this document

The caution and danger notices in this document are also in the multilingual *Safety Information* document, which is on the Lenovo *System x Documentation CD*. Each notice is numbered for reference to the corresponding notice in your language in the *Safety Information* document.

The following notices and notices are used in this document:

- **Note:** These notices provide important tips, guidance, or advice.
- **Important:** These notices provide information or advice that might help you avoid inconvenient or problem situations.
- **Attention:** These notices indicate potential damage to programs, devices, or data. An attention notice is placed just before the instruction or situation in which damage might occur.
- **CAUTION:** These notices indicate situations that can be potentially hazardous to you. A caution notice is placed just before the description of a potentially hazardous procedure, step, or situation.
- **DANGER:** These notices indicate situations that can be potentially lethal or extremely hazardous to you. A danger notice is placed just before the description of a potentially lethal or extremely hazardous procedure, step, or situation.

Chapter 2. About the Lenovo System x3250 M6 server

This chapter provides a summary of server features, technologies the server offers, and instructions on turning on and turning off the server.

General information

The Lenovo System x3250 M6 server is a 1-U¹-high rack model server for high-volume network transaction processing. This high-performance, multi-core server is ideally suited for networking environments that require superior microprocessor performance, input/output (I/O) flexibility, and high manageability.

The hot-swap server models support up to eight 2.5-inch hot-swap hard disk drives or four 3.5-inch hot-swap hard disk drives. The simple-swap server models support up to eight 2.5-inch simple-swap hard disk drives or four 3.5-inch simple-swap hard disk drives. The Lenovo System x3250 M6 server supports 2.5-inch hot-swap or simple-swap Serial Attached SCSI (SAS) or SATA hard disk drives, or 3.5-inch hot-swap SAS or SATA hard disk drives, or 3.5-inch simple-swap SATA hard disk drives.

For a list of supported optional devices for the server, go to:
<http://www.lenovo.com/serverproven/>

Record information about the server in the following table.

Table 1. Record of the system information

Product name	Machine types	Model number	Serial number
Lenovo System x3250 M6 server	Type 3633 and 3943		

The model number and serial number are on the ID label on the rack release latch of the server, as shown in the following illustration.

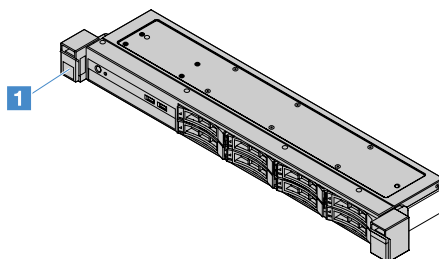

Figure 1. ID label on the front of the server

Performance, ease of use, reliability, and expansion capabilities were key considerations in the design of the server. These design features make it possible for you to customize the system hardware to meet your needs today and provide flexible expansion capabilities for the future.

Business Partners must also complete the steps in “Instructions for Business Partners” on page 173.

1. Racks are measured in vertical increments of 4.45 cm (1.75 inches) each. Each increment is called a "U." A 1-U-high device is 1.75 inches tall

Warranty and service information

The server comes with a limited warranty. For information about the terms of the warranty and getting service and assistance, see the *Lenovo Warranty Information* document that comes with the server.

The system service label, which is on the cover of the server, provides a QR code for mobile access to service information. You can scan the QR code using a QR code reader and scanner with a mobile device and get quick access to the Lenovo Service Information Web site. The Lenovo Service Information Web site provides additional information for parts installation and replacement videos, and error codes for server support.

If firmware and documentation updates are available, you can download them from the Lenovo Web site. The server might have features that are not described in the documentation that comes with the server, and the documentation might be updated occasionally to include information about those features, or technical updates might be available to provide additional information that is not included in the server documentation. To check for updates, go to <http://www.lenovo.com/support>.

You can obtain up-to-date information about the server and other Lenovo server products at <http://shop.lenovo.com/us/en/systems/>. At <http://www.lenovo.com/support>, you can create a personalized support page by identifying Lenovo products that are of interest to you. From this personalized page, you can subscribe to weekly email notifications about new technical documents, search for information and downloads, and access various administrative services.

Technologies and software information

The server contains X-Architecture next generation technologies, which help increase performance and reliability. For more information, see “What your server offers” on page 9 and “Reliability, Availability, and Serviceability” on page 12.

If you participate in the Lenovo client reference program, you can share information about your use of technology, best practices, and innovative solutions; build a professional network; and gain visibility for your business. For more information about the Lenovo client reference program, go to <http://www.ibm.com/ibm/clientreference/>.

Server features and specifications

The following information is a summary of the server features and specifications of the server. Depending on the model, some features might not be available, or some specifications might vary.

Microprocessor (depending on the model):

- One Intel® quad-core (Xeon® E3-1200 v5 series) or dual-core (Pentium® series, Celeron®, or Core™ i3 series) microprocessor
- Multi-chip package microprocessor architecture
- Designed for Land Grid Array (LGA) 1151 socket
- Scalable up to four cores
- Support Intel Flex Memory Technology

For the specific type and speed of the server microprocessor, view the information in the Setup Utility program. See “Using the Setup Utility program” on page 28.

For a list of supported microprocessors, go to:
<http://www.lenovo.com/serverproven/>

Memory:

- Minimum: 4 GB

- Maximum: 64 GB
- Types: PC4-17000 (dual-rank), 2133 MHz, error correcting code (ECC), double-data-rate 4 (DDR4) unbuffered dual inline memory modules (DIMMs) only
- Slots: four DIMM slots, two-way interleaved

Note: When a 4 GB or more of memory (physical or logical) is installed, part of the memory is reserved for various system resources and is unavailable to the operating system. The amount of memory that is reserved for system resources depends on the operating system, the server configuration, and the configured PCI options.

Optical drive:

- UltraSlim DVD-ROM combo
- Multi-burner

Hard disk drive expansion bays (depending on the model):

- Four 2.5-inch hot-swap SAS/SATA hard disk drive bays
- Four 2.5-inch simple-swap SAS/SATA hard disk drive bays
- Eight 2.5-inch hot-swap SAS/SATA hard disk drive bays
- Eight 2.5-inch simple-swap SAS/SATA hard disk drive bays
- Four 3.5-inch hot-swap SAS/SATA hard disk drive bays
- Four 3.5-inch simple-swap SATA hard disk drive bays

Attention: As a general consideration, do not mix standard 512 byte and advanced 4 KB format drives in the same Redundant Array of Independent Disks (RAID) array because doing so might lead to potential performance issues.

Peripheral Component Interconnect (PCI) Express expansion slots:

The server supports two PCIe riser slots on the riser card:

- Slot 1: dedicated to the ServeRAID M1210 SAS/SATA controller
- Slot 2: supports one PCI Express Gen3 x8 half-length, full-height adapter

Power supply (depending on the model):

- One fixed 300-watt power supply
- One or two 460-watt power supplies (hot-swap when two installed)

RAID controller:

ServeRAID C110 capabilities that support RAID levels 0, 1, 5, and 10

Integrated functions:

- Integrated Management Module II (IMM2), which consolidates multiple management functions in a single chip
- Intel i350-AM2 Gigabit Ethernet controller and Wake on LAN support
- Universal Serial Bus (USB):
 - Two USB 3.0 connectors on the front

Note: Due to the limitation of USB 3.0 connectors, the front USB connectors are not usable for the VMware ESXi 5.5 hypervisor.

- Two USB 3.0 connectors on the rear

- One USB 3.0 internal connector on the system board for the USB hypervisor key
- Four-port integrated SATA controller
- One-port integrated SATA port for the optical drive (optional)
- One serial port header (functional with Serial Port Upgrade Kit installed)
- One video graphics array (VGA) connector on the rear

Video controller (integrated into IMM2):

- Matrox G200eR2
- SVGA compatible video controller
- AAVICA hardware video compression
- Video memory is not expandable
- Maximum video resolution: 1600 x 1200 at 75 Hz

Size:

- 1U
- Height: 43 mm (1.69 inches)
- Depth: 576 mm (22.68 inches)
- Width:
 - Without Electronic Industries Association (EIA) brackets: 434.6 mm (17.11 inches)
 - With EIA brackets: 482 mm (18.98 inches)
- Maximum weight: 13.8 kg (30.36 lb)

Acoustical noise emissions:

Sound power: 5.4 bels for both idle and operating environment

In the idle environment, the server is only running the operating system. In the operating environment, the microprocessor is active and the thermal design power (TDP) is occupied 50%.

The noise emission level stated is the declared upper limit sound power level, in bels, for a random sample of machines. All measurements are made in accordance with ISO 7779 and reported in conformance with ISO 9296.

Environment:

- Air temperature:
 - Server on: 10°C to 35°C (50.0°F to 95.0°F); altitude: 0 m to 914.4 m (0 ft to 3000 ft)
 - Server on: 10°C to 32°C (50.0°F to 89.6°F); altitude: 914.4 m to 2133.6 m (3000 ft to 7000 ft)
 - Server on: 10°C to 28°C (50.0°F to 83°F); altitude: 2133.6 m to 3050 m (7000 ft to 10 000 ft)
 - Server off: 10°C to 43°C (50°F to 109.4°F)
 - Shipping: -40°C to 60°C (-40°F to 140°F)
- Humidity: 8% to 80%
- Particulate contamination:

Airborne particulates and reactive gases acting alone or in combination with other environmental factors such as humidity or temperature might pose a risk to the server. For information about the limits for particulates and gases, see “Particulate contamination” on page 667.

When the operating temperature enhancement kit is installed, the temperature response for the fan speed control is more accurate.

Heat output:

- Minimum configuration: 143 BTU per hour (42 watts)
- Maximum configuration: 710 BTU per hour (208 watts)

Electrical input:

- Sine-wave input (50 Hz to 60 Hz) required
- Input voltage low range:
 - Minimum: 100 V ac
 - Maximum: 127 V ac
- Input voltage high range:
 - Minimum: 200 V ac
 - Maximum: 240 V ac
- Input kilovolt-amperes (kVA):
 - Minimum: 0.042 kVA
 - Maximum: 0.508 kVA

Note: Power consumption and heat output vary depending on the number and type of optional features installed and the power-management optional features in use.

What your server offers

The server offers the following features and technologies:

- **Dynamic System Analysis (DSA)**

The server comes with the Dynamic System Analysis (DSA) Preboot diagnostic program stored in the integrated USB memory on the server. DSA collects and analyzes system information to aid in diagnosing server problems, as well as offering a rich set of diagnostic tests of the major components of the server. DSA creates a DSA log, which is a chronologically ordered merge of the system-event log (as the IPMI event log), the Integrated Management Module II (IMM2) event log (as the ASM event log), and the operating-system event logs. You can send the DSA log as a file to Lenovo Support or view the information as a text file or Hypertext Markup Language (HTML) file.

- **Features on Demand**

If the Features on Demand feature is integrated in the server or in an optional device that is installed in the server, you can purchase an activation key to activate the feature. For information about Features on Demand, go to <http://www.ibm.com/systems/x/fod/>.

- **ServerGuide Setup and Installation CD**

The *ServerGuide Setup and Installation CD*. You can download the ISO image of the CD from the Web site, provides programs to help you set up the server and install a Windows operating system. The ServerGuide program detects installed optional hardware devices and provides the correct configuration programs and device drivers. For more information about the *ServerGuide Setup and Installation CD*, see “Using the ServerGuide Setup and Installation CD” on page 27.

- **Lenovo XClarity Administrator**

Lenovo XClarity Administrator is a centralized, resource-management solution that simplifies infrastructure management, speeds responses, and enhances the availability of Lenovo server systems and solutions. It runs as a virtual appliance that automates discovery, inventory, tracking, monitoring, and provisioning for Lenovo servers in a secure environment. For more information, see “Using Lenovo XClarity Administrator” on page 39.

- **Lenovo ThinkServer Power Planner**

The Lenovo ThinkServer Power Planner program provides power consumption information and electric current calculation based on the different configurations of servers and other devices. The program also helps to plan servers and devices deployment in an efficient way.

For more information about using the Lenovo ThinkServer Power Planner program, refer to the help system of the program.

- **Lenovo ToolsCenter Suite CLI**

Lenovo ToolsCenter Suite CLI is a collection of server management tools that utilize a command-line interface program to manage firmware, hardware, and operating systems for CMM, IMM, and Flex-IOM based systems using the applications. Lenovo ToolsCenter Suite CLI is comprised of individual ToolsCenter application modules that are easily updated. For more information, go to <https://support.lenovo.com/us/en/documents/LNVO-CENTER>.

- **Integrated Management Module II (IMM2)**

The Integrated Management Module II (IMM2) combines service processor functions, video controller, and remote presence and blue-screen capture features in a single chip. The IMM2 provides advanced service-processor control, monitoring, and alerting function. If an environmental condition exceeds a threshold or if a system component fails, the IMM2 lights LEDs to help you diagnose the problem, records the error in the IMM2 event log, and alerts you to the problem. Optionally, the IMM2 also provides a virtual presence capability for remote server management. The IMM2 provides remote server management through the following industry-standard interfaces:

- Intelligent Platform Management Interface (IPMI) 2.0
- Simple Network Management Protocol (SNMP) 3.0
- Common Information Model (CIM)
- Web browser

For more information, see “Using the Integrated Management Module II (IMM2)” on page 35 and the *Integrated Management Module II User’s Guide* at: <http://www.lenovo.com/support>

- **Integrated network support**

The server comes with an integrated dual-port Intel Gigabit Ethernet controller, which supports connection to a 10 Mbps, 100 Mbps, or 1000 Mbps network. For more information, see “Ethernet controller information” on page 38.

- **Integrated Trusted Platform Module (TPM)**

This integrated security chip performs cryptographic functions and stores private and public secure keys. It provides the hardware support for the Trusted Computing Group (TCG) specification. You can download the software to support the TCG specification, when the software is available. For details about the TPM implementation, go to <http://www.ibm.com/systems/x/hardware/enterprise/index.html>. You can enable TPM support through the **System Security** menu of the Setup Utility program. See “Using the Setup Utility program” on page 28.

- **Large data-storage capacity and hot-swap capability**

The server supports a maximum of eight 2.5-inch hot-swap or simple-swap Serial Attached SCSI (SAS) or Serial ATA (SATA) hard disk drives, or four 3.5-inch hot-swap or simple-swap SAS/SATA hard disk drives, depending on the server model.

- **Large system-memory capacity**

The server supports up to 64 GB of system memory. The memory controller supports error correcting code (ECC) for up to four industry-standard PC4-17000 (DDR4-2133) UDIMMs.

- **Mobile access to the Lenovo Service Information Web site**

The server provides a QR code on the system service label, which is on the cover of the server. You can scan the QR code using a QR code reader and scanner with a mobile device to get quick access to the Lenovo Service Information Web site. The Lenovo Service Information Web site provides additional

information for server support, such as parts installation and replacement videos, and error codes for server support.

The following illustration shows the QR code

<http://support.lenovo.com/us/en/products/servers/lenovo-x86-servers/lenovo-system-x3250-m6>



Figure 2. QR code

- **Multi-core processing**

The server supports an Intel Pentium, Celeron, Core i3, or Xeon E3-1200 v5 series multi-core microprocessor.

- **PCIe adapter capabilities**

The server has two PCIe interface slots. Both slots can support PCI Express adapters. See “Installing an adapter” on page 111 for detailed information.

- **Cooling and optional power capabilities**

The server supports four speed-controlled simple-swap fans for a full configuration. The server comes with one 300-watt fixed power supply, or one 460-watt hot-swap power supply installed. The server supports a maximum of two 460-watt hot-swap power supplies. For redundancy support on hot-swap models, two power-supplies must be installed in the server. Two power supplies enable continued operation if one of the power supplies fails.

- **ServeRAID support**

The standard RAID adapter provides RAID levels 0, 1, and 10. Additional optional RAID adapters that provide RAID level 5 are available for purchase. The ServeRAID M5200 Series adapters provide RAID level 6 if a Features on Demand upgrade key for RAID is available.

- **System-management capabilities**

The server comes with an Integrated Management Module II (IMM2). The IMM2, when used with the system-management software that comes with the server, enables you to manage the functions of the server locally and remotely. The IMM2 also provides system monitor, event record, and network alert capability. The system-management connector for the IMM2 is on the rear of the server.

- **UEFI-compliant server firmware**

The Unified Extensible Firmware Interface (UEFI) firmware offers several features, including UEFI version 2.1 compliance; enhanced reliability, availability, and serviceability (RAS), and basic input/output system (BIOS) compatibility support. UEFI replaces the traditional BIOS interface with a better BIOS and defines a standard interface between the operating system, platform firmware, and external devices. The server is capable of booting UEFI-compliant operating systems, BIOS-based operating systems, and BIOS-based adapters as well as UEFI-compliant adapters. For more information about UEFI-compliant firmware, go to: <http://www.ibm.com/support/entry/portal/docdisplay?Indocid=MIGR-5083207>

Note: The server does not support Disk Operating System (DOS).

- **VMware ESXi embedded hypervisor**

An optional USB flash device with VMware ESXi embedded hypervisor software is available for purchase. Hypervisor is virtualization software that enables multiple operating systems to run on a host system at the same time. For more information, see “Using the embedded hypervisor” on page 37.

Reliability, Availability, and Serviceability

Three important computer design features are reliability, availability, and serviceability (RAS). The RAS features help to ensure the integrity of the data that is stored on the server, the availability of the server when you need it, and the ease with which you can diagnose and correct problems.

Your server has the following RAS features:

- 3-year parts and 3-year labor limited warranty (Machine Type 3633)
- 1-year parts and 1-year labor limited warranty (Machine Type 3943)
- Backup basic input/output system switching under the control of the Integrated Management Module II (IMM2)
- 24-hour support center
- Call Home Service
- First Failure Data Capture (FFDC) for determining failure root cause
- Extended Error Handling (EEH) for PCIe host and root complex, PCIe link, and PCIe adapter failures
- Power-supply error detection
- VRD Fault Detection
- I/O Fault Handling
- Microprocessor Internal Error Detection
- Microprocessor Internal Thermal Trip
- Error correcting code (ECC) L2 cache and system memory
- Redundant hot-swap power supplies
- Hot-swap hard disk drives
- Advanced memory features:
 - Single-bit memory error detection
 - Single-bit memory error hardware correction
 - Multi single-bit memory error detection
- Microprocessor Throttling
- Memory Thermal Throttling
- Predictive Failure Analysis (PFA) alerts
- Integrated management module (IMM)
- system-management monitoring through the Inter-Integrated Circuit (IC) protocol bus
- Standby voltage for system-management features and monitoring
- Power managed and Advanced Configuration and Power Interface (ACPI) compliant
- Power-on self-test (POST)
- System-error logging (POST and IMM)
- Error codes and messages
- Information and light path diagnostics LED panels
- Memory SPD and TruDDR4 Initiative
- NIC Failover Support
- Automatic restart on nonmaskable interrupt (NMI)
- Force O/S-dump (NMI Button)
- Boot from USB Device
- Remote System Reboot
- Automatic error retry and recovery
- Excessive Temperature Recovery
- Restore default CMOS settings button
- Vital product data (VPD) unique identifiers on blade server and all major electronic components with information stored in nonvolatile memory for remote viewing
- Ambient Temperature monitors and alerts
- Memory Temperature monitors and alerts
- Processor Temperature monitors and alerts
- Upgradeable POST, Unified Extensible Firmware Interface (UEFI), diagnostics, IMM firmware, and read-only memory (ROM) resident code, locally or over the LAN

- On-Board Pre-Boot Diagnostics
- Ethernet Diagnostics
- RAID Diagnostics
- Installation and Service Guide

Turning on or turning off the server

When the server is connected to an ac power source but is not turned on, the operating system does not run, and all core logic except for the Integrated Management Module II (IMM2) is shut down.

However, the server can respond to requests from Integrated Management Module II (IMM2), such as a remote request to turn on the server. The power-on LED flashes to indicate that the server is connected to ac power but is not turned on.

Turning on the server

Approximately 20 seconds after the server is connected to ac power, one or more fans might start running to provide cooling and the power-on button LED starts blinking quickly. Approximately one to three minutes after the server is connected to ac power, the power-control button becomes active and the blink of the power-on button LED turns slow.

You can turn on the server by pressing the power-control button.

You also can turn on the server through the Wake on LAN feature if supported by the operating system. You can send a request through the Wake on LAN feature to turn on the server remotely.

Besides, if a power failure occurs while the server is turned on, the server will restart automatically when power is restored.

Turning off the server

Use this information to turn off the server.

When you turn off the server and leave it connected to ac power, the server can respond to requests from the Integrated Management Module II (IMM2), such as a remote request to turn on the server. While the server remains connected to ac power, one or more fans might continue to run. To remove all power from the server, you must disconnect the server from the power source.

Some operating systems require an orderly shutdown before you turn off the server. For information about shutting down the operating system, see your operating-system documentation or help system.



CAUTION:

The power control button on the device and the power switch on the power supply do not turn off the electrical current supplied to the device. The device also might have more than one power cord. To remove all electrical current from the device, ensure that all power cords are disconnected from the power source.

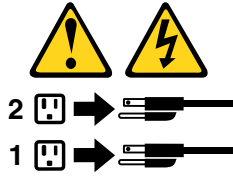

The server can be turned off in any of the following ways:

- You can turn off the server from the operating system, if your operating system supports this feature. After an orderly shutdown of the operating system, the server turns off automatically.
- You can press the power-control button to start an orderly shutdown of the operating system and turn off the server, if your operating system supports this feature.
- If the operating system stops functioning, you can press and hold the power-control button for more than four seconds to turn off the server.
- The server can be turned off through Wake on LAN.

Note: When you install any PCIe adapter, the power cords must be disconnected from the power source before you remove the PCI riser-card assembly. Otherwise, the Wake on LAN feature might not work.

- The Integrated Management Module II (IMM2) can turn off the server as an automatic response to a critical system failure.

Chapter 3. Component locations

This chapter provides information to help you locate server components.

Note: The illustrations in this document might differ slightly from your server.

Front view

The following illustration shows the controls, LEDs, and connectors on the front of the server.

Note: * Available on server models with hot-swap hard disk drives

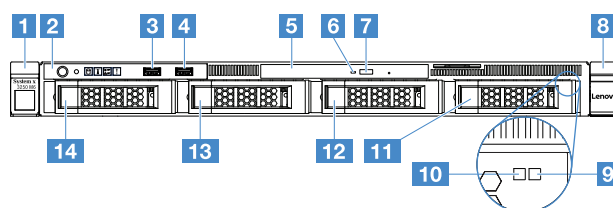

Figure 3. Front view of server models with four 3.5-inch hard disk drives

1 Rack release latch (left)	2 Operator information panel
3 USB connector 1	4 USB connector 2
5 Optical drive bay	6 Optical drive activity LED
7 Optical drive eject button	8 Rack release latch (right)
9 Hard disk drive status LED* (yellow)	10 Hard disk drive activity LED* (green)
11 Hard disk drive bay 3	12 Hard disk drive bay 2
13 Hard disk drive bay 1	14 Hard disk drive bay 0

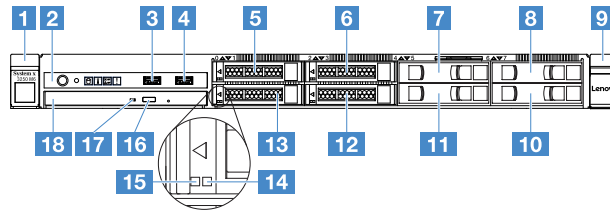

Figure 4. Front view of server models with four 2.5-inch hard disk drives

1 Rack release latch (left)	2 Operator information panel
3 USB connector 1	4 USB connector 2
5 Hard disk drive bay 0	6 Hard disk drive bay 2
7 Hard disk drive bay 4	8 Hard disk drive bay 6
9 Rack release latch (right)	10 Hard disk drive bay 7
11 Hard disk drive bay 5	12 Hard disk drive bay 3
13 Hard disk drive bay 1	14 Hard disk drive status LED* (yellow)
15 Hard disk drive activity LED* (green)	16 Optical drive eject button
17 Optical drive activity LED	18 Optical drive bay

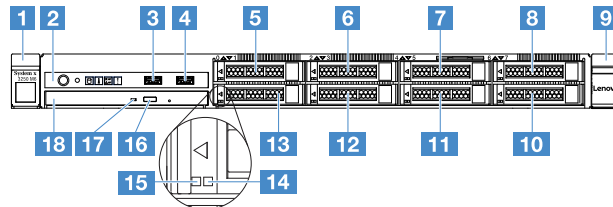

Figure 5. Front view of server models with eight 2.5-inch hard disk drives

1 Rack release latch (left)	2 Operator information panel
3 USB connector 1	4 USB connector 2
5 Hard disk drive bay 0	6 Hard disk drive bay 2
7 Hard disk drive bay 4	8 Hard disk drive bay 6
9 Rack release latch (right)	10 Hard disk drive bay 7
11 Hard disk drive bay 5	12 Hard disk drive bay 3
13 Hard disk drive bay 1	14 Hard disk drive status LED* (yellow)
15 Hard disk drive activity LED* (green)	16 Optical drive eject button
17 Optical drive activity LED	18 Optical drive bay

- **Rack release latches:**

Press the latches on each front side of the server to remove the server from the rack.

- **Hard disk drive activity LED:**

This LED is used on hot-swap SAS or SATA hard disk drives. When this LED is flashing, it indicates that the drive is in use.

- **Hard disk drive status LED:**

This LED is used on hot-swap SAS or SATA hard disk drives. When this LED is lit, it indicates that the drive has failed. If an optional ServeRAID controller is installed in the server, when this LED is flashing slowly (one flash per second), it indicates that the drive is being rebuilt. When this LED is flashing rapidly (three flashes per second), it indicates that the controller is identifying the drive.

- **USB connectors:**

Connect a USB device, such as a USB mouse, keyboard, or other device to any of these connectors.

- **Optical drive eject button:**

Press this button to eject the disc tray from the optical drive.

- **Optical drive activity LED:**

When this LED is lit, it indicates that the optical drive is in use.

- **Operator information panel:**

This panel contains controls and LEDs that provide information about the status of the server.

Rear view

The following illustrations show the connectors and LEDs on the rear of the server.

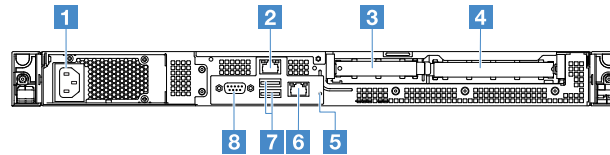

Figure 6. Rear view of the server with fixed power-supply

1 Power-cord connector	2 Ethernet connector 2
3 PCI slot 1	4 PCI slot 2
5 NMI button	6 Ethernet connector 1 for system management
7 USB connectors	8 VGA connector

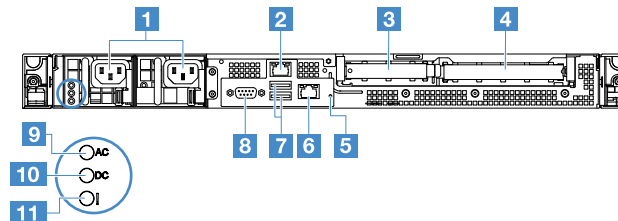
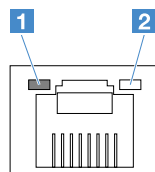

Figure 7. Rear view of the server with the redundant power-supply model

1 Power-cord connectors	2 Ethernet connector 2
3 PCI slot 1	4 PCI slot 2

5 NMI button	6 Ethernet connector 1 for system management
7 USB connectors	8 Video connector
9 ac power LED (green)	10 dc power LED (green)
11 Power-supply error LED (yellow)	



1 Ethernet link LED

2 Ethernet activity LED

- **Ethernet link LEDs:** When these LEDs are lit, they indicate that there is an active link connection on the 10BASE-T, 100BASE-TX, or 1000BASE-TX interface for the Ethernet connector.
- **Ethernet activity LEDs:** When these LEDs are lit, they indicate that there is activity between the server and the network.
- **ac power LED**
- **dc power LED**
These LEDs show the status of the power supply. During normal operation, both of them are lit in green. For more power-supply status information, see “Power-supply LEDs” on page 54.
- **Power-supply error LED:** When this yellow LED is lit, it indicates that the power supply has failed.
- **Power cord connector:** Connect the power cord to this connector.
- **VGA connector:** Connect a monitor to this connector.
- **USB connectors:** Connect a USB device, such as a USB mouse, keyboard, or other device to any of these connectors.
- **Ethernet connectors:** Use either of these connectors to connect the server to a network. When you use the Ethernet 1 connector, the network can be shared with the IMM2 through a single network cable.
- **NMI button:** Press this button to force a nonmaskable interrupt (NMI) to the microprocessor. By this way, you can blue screen the server and take a memory dump. You might have to use a pen or the end of a straightened paper clip to press the button.

Note: Use this button only when directed by the Lenovo service support

- **PCI slot 1:** This slot is dedicated to ServeRAID M1210 SAS/SATA controller
- **PCI slot 2:** This slot supports one PCI Express Gen3 x8 half-length, full-height adapter

Operator information panel

The following illustration shows the controls and LEDs on the operator information panel.

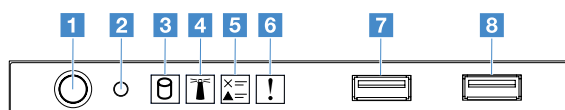

Figure 8. Operator information panel

1 Power-control button and power-on LED	Press this button to turn on or turn off the server manually. The states of the power-on LED are as follows:
	<ul style="list-style-type: none"> • Off: Power is not present, otherwise the power supply or the LED itself has failed. • Flashing rapidly (four times per second): The server is turned off and is not ready to be turned on. The power-control button is disabled. This will last approximately 20 seconds. • Flashing slowly (once per second): The server is turned off and is ready to be turned on. You can press the power-control button to turn on the server. • On: The server is turned on.
2 Reset button	Press this button to reset the server and run the power-on self-test (POST). You might have to use a pen or the end of a straightened paper clip to press the button.
3 Hard disk drive activity LED	When this LED is flashing, it indicates that the associated hard disk drive is in use.
4 System-locator LED	Use this blue LED to locate the server among other servers visually. This LED is also used as a presence detection button. You can use Lenovo XClarity Administrator to light this LED remotely.
5 Check log LED	When this yellow LED is lit, it indicates that a system error has occurred. Check the event log for additional information. For more information, see “Event logs” on page 56.
6 System-error LED	When this yellow LED is lit, it indicates that a system error has occurred. For more information, see “Event logs” on page 56.
7 USB connector 1	Connect a USB device, such as a USB mouse, keyboard, or other device to any of these connectors.
8 USB connector 2	

Server components

The following illustration shows the major components in the server.

The illustrations in this document might differ slightly from your hardware.

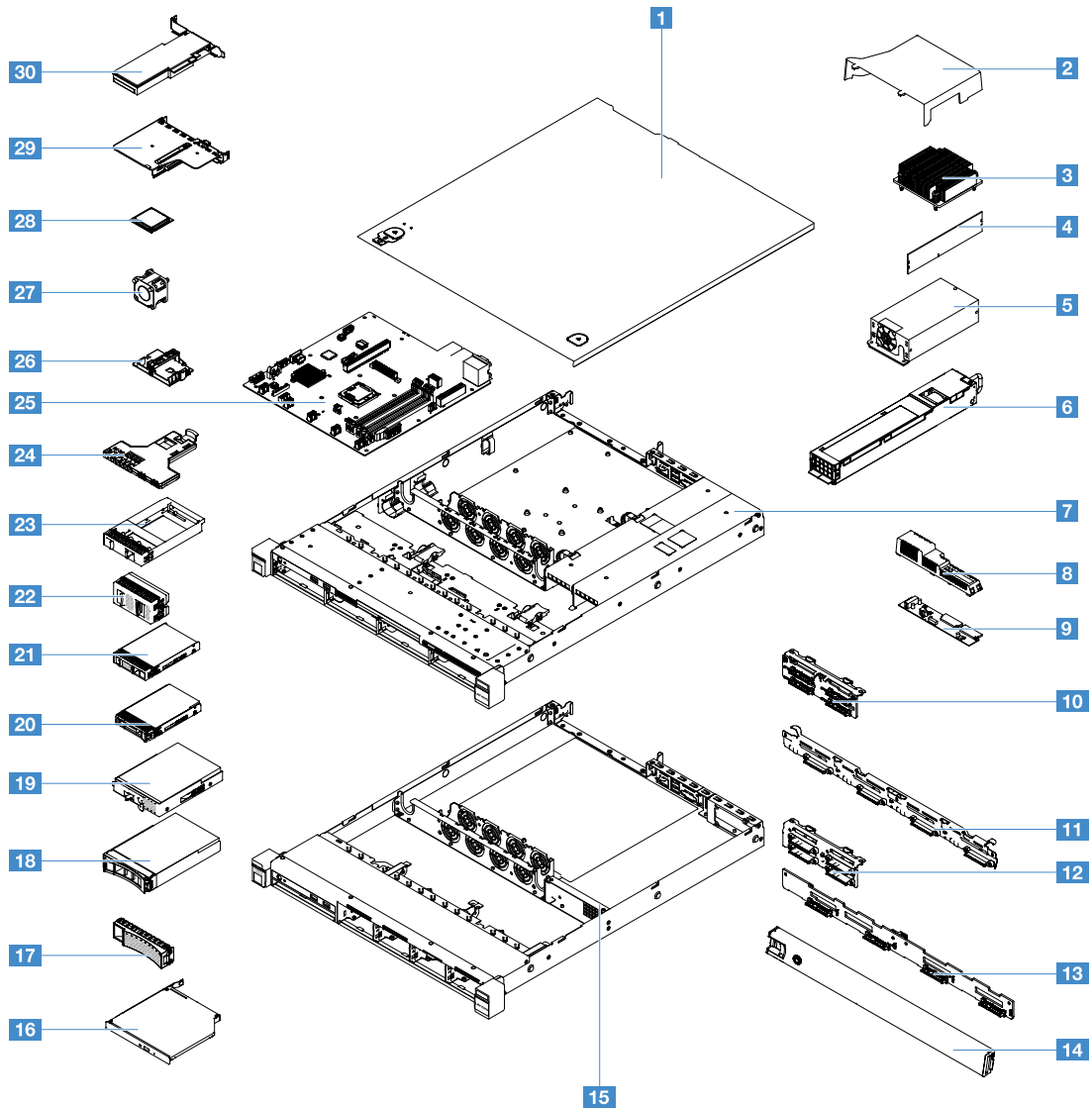

Figure 9. Server components

1 Server cover ⁴	2 Air baffle ⁴
3 Heat sink ²	4 Memory module ¹
5 Fixed power supply* ²	6 Hot-swap power supply* ¹
7 Chassis of 3.5-inch hard disk drive model with hot-swap power supply* ⁴	8 Power distribution board cover* ⁴
9 Power distribution board* ²	10 2.5-inch simple-swap hard-disk-drive backplate assembly* ²
11 3.5-inch simple-swap hard-disk-drive backplate assembly* ²	12 2.5-inch hot-swap hard-disk-drive backplane* ¹
13 3.5-inch hot-swap hard-disk-drive backplane* ¹	14 Security bezel ³
15 Chassis of 2.5-inch hard disk drive model with fixed power supply* ⁴	16 Optical drive ¹
17 3.5-inch hard disk drive filler* ⁴	18 3.5-inch hot-swap hard disk drive* ¹

19 3.5-inch simple-swap hard disk drive* ¹	20 2.5-inch hot-swap hard disk drive* ¹
21 2.5-inch simple-swap hard disk drive* ¹	22 2.5-inch hard disk drive filler (for two hard disk drives)* ³
23 2.5-inch hard disk drive filler (for one hard disk drive)* ¹	24 Front I/O assembly ¹
25 System board ²	26 RAID adapter battery or flash power module holder* ⁴
27 System fan ¹	28 Microprocessor ²
29 PCI riser-card assembly* ¹	30 RAID card* ¹

Blue on a component indicates touch points, where you can grip the component to remove it from or install it in the server, open or close a latch, and so on.

Orange on a component or an orange label on or near a component indicates that the component can be hot-swapped. This means that if the server and operating system support hot-swap capability, you can remove or install the component while the server is running. Orange can also indicate touch points on hot-swap components.

Notes:

- * Available on some models
- ¹ Tier 1 customer replaceable unit (CRU): Replacement of Tier 1 CRUs is your responsibility. If Lenovo installs a Tier 1 CRU at your request, you will be charged for the installation.
- ² Tier 2 customer replaceable unit (CRU): You may install a Tier 2 CRU yourself or request Lenovo to install it, at no additional charge, under the type of warranty service that is designated for your server.
- ³ Structural parts: Purchase and replacement of structural parts (such as chassis assembly, cover, and bezel) is your responsibility. If Lenovo acquires or installs a structural part at your request, you will be charged for the service.
- ⁴ Consumable parts: Parts that are purchased separately and not covered by the Lenovo Statement of Limited Warranty.

Before servicing a Lenovo product, ensure that you read and understand “Safety” on page v. Use only parts provided by Lenovo for replacement. For a complete listing of FRU information, such as FRU part numbers and supported server models, go to:
<http://www.lenovo.com/serviceparts-lookup>

System-board connectors

The following illustration shows the connectors on the system board.

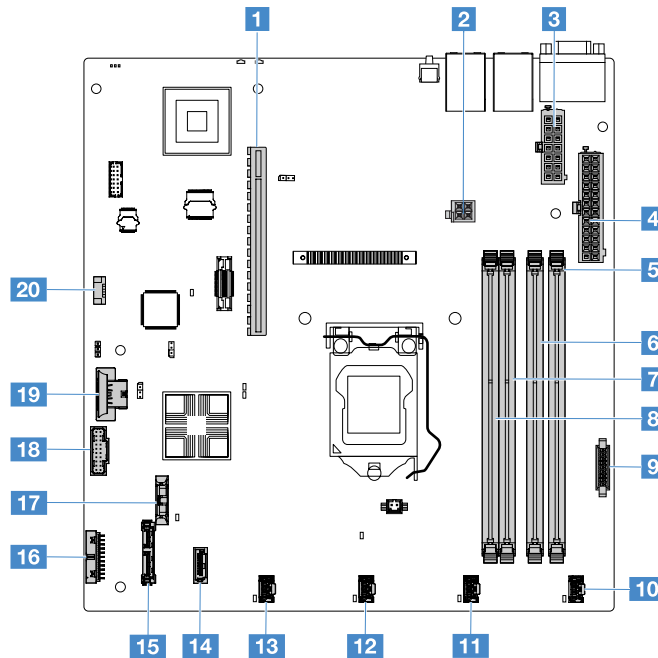

Figure 10. Connectors on the system board

1 PCI riser card connector	2 Microprocessor power connector
3 Power supply connector	4 Backplane power connector
5 DIMM slot 1	6 DIMM slot 2
7 DIMM slot 3	8 DIMM slot 4
9 Power distribution board connector	10 System fan 1 connector
11 System fan 2 connector	12 System fan 3 connector
13 System fan 4 connector	14 Mini-SAS connector
15 SATA optical drive connector	16 Operation information panel connector
17 Coin-cell battery connector	18 Front USB connector
19 USB hypervisor key connector	20 Operating temperature enhancement kit connector

System-board switches and jumpers

This topic helps you locate the jumpers and switches on the system board and get familiar with their functions.

Important:

- Before you change any switch settings or move any jumpers, turn off the server. Then, disconnect all power cords and external cables. Review the information in “Safety” on page v, “Before removing or installing server components” on page 87, and “Turning off the server” on page 13.
- Any system-board switch or jumper block that is not shown in the illustrations in this document are reserved.
- If there is a clear protective sticker on the switch blocks, you must remove and discard it to access the switches.

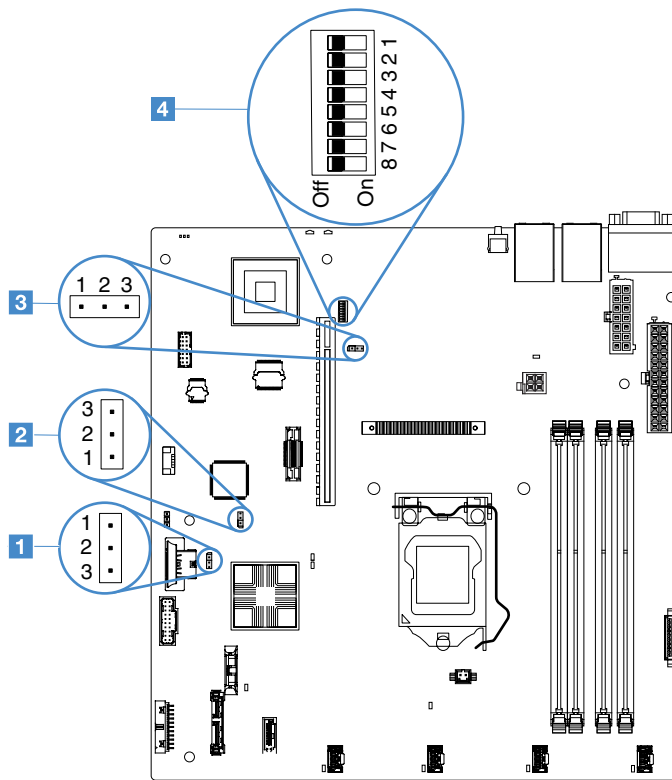

Figure 11. Switches and jumpers on the system board

1 Clear CMOS jumper	2 UEFI boot backup jumper (JP24)
3 TPM physical presence jumper (JP39)	4 SW1 switch block

The following table describes the jumpers on the system board.

Table 2. Jumpers definition

Jumper name	Description
Clear CMOS jumper	<ul style="list-style-type: none"> Pins 1 and 2 (default): Keep the CMOS data. Pins 2 and 3: Clear the CMOS data.
UEFI boot backup jumper	<ul style="list-style-type: none"> Pins 1 and 2 (default): Load the primary server firmware ROM page. Pins 2 and 3: Boot from backup and load the secondary (backup) server firmware ROM page.
TPM physical presence jumper	<ul style="list-style-type: none"> Pins 1 and 2: Default off Pins 2 and 3: Indicates a physical presence to the system TPM

If no jumper is present, the server responds as if the pins are set to the default.

Note: Changing the position of the UEFI boot backup jumper from pins 1 and 2 to pins 2 and 3 before the server is turned on alters which flash ROM page is loaded. Do not change the jumper pin position after the server is turned on. This can cause an unpredictable problem.

Table 3. SW1 switch block definition

Switch number	Default position	Description
1, 3, 4, 5, 6, 7, 8	Off	Reserved.
2	Off	<p>Power-on password overrides. Changing the position of this switch bypasses the power-on password check the next time the server is turned on and starts the Setup Utility so that you can change or delete the power-on password. You do not have to move the switch back to the default position after the power-on password is overridden.</p> <p>Changing the position of this switch does not affect the administrator password check if an administrator password is set.</p> <p>See “Passwords” on page 32 for additional information about passwords.</p>

System-board LEDs

The following illustration shows the light-emitting diodes (LEDs) on the system board.

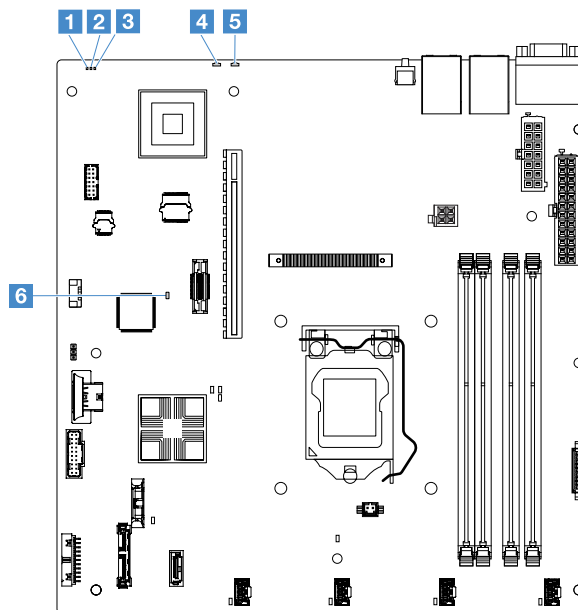

Figure 12. LEDs on the system board

1 Complex Programmable Logic Device (CPLD) heartbeat LED	2 Power LED
3 IMM heartbeat LED	4 System-error LED
5 System-locator LED	6 Field-Programmable Gate Array (FPGA) error LED

Chapter 4. Configuration information

This chapter provides information about updating the firmware and using the configuration utilities.

Updating the firmware

Important:

- Some cluster solutions require specific code levels or coordinated code updates. If the device is part of a cluster solution, verify that the latest level of code is supported for the cluster solution before you update the code.
- Before you update the firmware, be sure to back up any data that is stored in the Trusted Platform Module (TPM), in case any of the TPM characteristics are changed by the new firmware. For instructions, see your encryption software documentation.
- Installing the wrong firmware or device-driver update might cause the server to malfunction. Before you install a firmware or device-driver update, read any readme and change history files that are provided with the downloaded update. These files contain important information about the update and the procedure for installing the update, including any special procedure for updating from an early firmware or device-driver version to the latest version.

You can install code updates that are packaged as an UpdateXpress System Pack or UpdateXpress CD image. An UpdateXpress System Pack contains an integration-tested bundle of online firmware and device-driver updates for your server. Use UpdateXpress System Pack Installer to acquire and apply UpdateXpress System Packs and individual firmware and device-driver updates. For additional information and to download the UpdateXpress System Pack Installer, go to the ToolsCenter for System x and BladeCenter at <https://support.lenovo.com/us/en/documents/LNVO-CENTER> and click **UpdateXpress System Pack Installer**.

When you click an update, an information page is displayed, including a list of the problems that the update fixes. Review this list for your specific problem; however, even if your problem is not listed, installing the update might solve the problem.

Be sure to separately install any listed critical updates that have release dates that are later than the release date of the UpdateXpress System Pack or UpdateXpress image.

The firmware for the server is periodically updated and is available for download on the Lenovo Web site. To check for the latest level of firmware, such as the UEFI firmware, device drivers, and Integrated Management Module II (IMM2) firmware, go to <http://www.ibm.com/support/fixcentral>.

Download the latest firmware for the server; then, install the firmware, using the instructions that are included with the downloaded files.

When you replace a device in the server, you might have to update the firmware that is stored in memory on the device or restore the pre-existing firmware from a CD or DVD image.

The following list indicates where the firmware is stored:

- UEFI firmware is stored in ROM on the system board.
- IMM2 firmware is stored in ROM on the system board.
- Ethernet firmware is stored in ROM on the Ethernet controller and on the system board.
- ServeRAID firmware is stored in ROM on the PCIe RAID adapter (if one is installed).

- SAS/SATA firmware is stored in ROM on the SAS/SATA controller on the system board.

Configuring the server

To configure your server, consider the following various aspects:

- **Setup Utility**

Setup Utility is part of the UEFI firmware. Use Setup Utility to change interrupt request (IRQ) settings, change the startup-device sequence, set system date and time, set passwords, and perform other configuration tasks. For more information, see “Using the Setup Utility program” on page 28.

- **Boot Manager**

Boot Manager is part of the UEFI firmware. Use Boot Manager to override the startup sequence that is set in the Setup Utility and temporarily assign a first startup device. For more information, see “Using the Boot Manager program” on page 34.

- **Lenovo ServerGuide Setup and Installation CD**

The ServerGuide program is available on the *ServerGuide Setup and Installation* CD. This program provides software-setup tools and installation tools that are designed for the server. Use this CD during the installation of the server to configure basic hardware features, such as an integrated SAS/SATA controller with RAID capabilities, and to simplify the installation of your operating system. For more information, see “Using the ServerGuide Setup and Installation CD” on page 27.

- **Integrated Management Module II (IMM2)**

Use the Integrated Management Module II (IMM2) for configure the server, update the firmware, update the sensor data record/field replaceable unit (SDR/FRU) data, and remotely manage a network. For information about using the IMM2, see “Using the Integrated Management Module II (IMM2)” on page 35.

- **VMware ESXi embedded hypervisor**

An optional USB flash device with VMware ESXi embedded hypervisor software is available for purchase. Hypervisor is virtualization software that enables multiple operating systems to run on a host system at the same time. For more information about using the embedded hypervisor, see “Using the embedded hypervisor” on page 37.

- **Remote presence capability and blue-screen capture**

The remote presence and blue-screen capture are integrated features of the Integrated Management Module II (IMM2). The remote presence feature provides the following functions:

- Remotely viewing videos with graphics resolutions up to 1600 x 1200 at 75 Hz, regardless of the system state
- Remotely accessing the server, using the keyboard and mouse from a remote client
- Mapping the CD or DVD drive, and USB flash drive on a remote client, and mapping ISO image files as virtual drives that are available for use by the server
- Uploading a diskette image to the IMM2 memory and mapping it to the server as a virtual drive

The blue-screen capture feature captures the video display contents before the IMM2 restarts the server when the IMM2 detects an operating-system hang condition. A system administrator can use the blue-screen capture feature to assist in determining the cause of the hang condition. For more information, see “Using the remote presence and blue-screen capture features” on page 36.

- **Ethernet controller configuration**

For information about configuring the Ethernet controller, see “Ethernet controller information” on page 38.

- **Features on Demand**

The server provides the Features on Demand (FoD) software Ethernet support. You can purchase a FoD software upgrade key for Fibre Channel over Ethernet (FCoE) and iSCSI storage protocols. For more information, see “Enabling Features on Demand Ethernet and Demand RAID software” on page 38.

- **ToolsCenter Suit CLI program**

The Lenovo ToolsCenter Suite CLI program is a collection of server management tools that utilize a command-line interface program to manage firmware, hardware, and operating systems. It covers the configuration function, which is an alternative to Setup Utility for modifying UEFI settings. For more information about using this program, see “Lenovo ToolsCenter Suite CLI program” on page 39.

- **RAID configuration**

For information about configuring RAID, see “Accessing RAID configuration utility” on page 39.

The following table lists the applications that are available for configuring and managing RAID.

Table 4. Server configuration and applications for configuring and managing RAID

Server configuration	RAID configuration (before operating system is installed)	RAID management (after installing the operating system)
ServeRAID M1210 SAS/SATA Controller ServeRAID M1215 SAS/SATA Controller ServeRAID M5210 SAS/SATA Controller ServeRAID M5225-2 GB SAS/SATA Controller	<ul style="list-style-type: none"> – LSI Utility: (Press Ctrl+C in Setup Utility when under the legacy BIOS boot.) – ServerGuide – Human Interface Infrastructure (HII) 	<ul style="list-style-type: none"> – MegaRAID Storage Manager (MSM), – StorCLI (Command Line) Utility for Storage Management
Software RAID	<ul style="list-style-type: none"> – Intel Utility: (Press Ctrl+I in Setup Utility when under the legacy BIOS boot) – ServerGuide – Human Interface Infrastructure (HII) 	<ul style="list-style-type: none"> – Graphical utility (Windows only) – Command Line: rstcli (Windows) and mdadm (Linux) Utility for Storage Management

For more information about Human Interface Infrastructure (HII) and StorCLI, go to:
ftp://ftp.software.ibm.com/systems/support/system_x_pdf/ibm_doc_mpt2sas_hiic-2011-09_user-guide.pdf

For more information about MegaRAID, go to:
<http://www.ibm.com/support/entry/portal/docdisplay?Indocid=MIGR-5073015>

Using the ServerGuide Setup and Installation CD

Use this information as an overview for using the *ServerGuide Setup and Installation CD*.

The *ServerGuide Setup and Installation CD* provides software setup tools and installation tools that are designed for your server. The ServerGuide program detects the server model and optional hardware devices that are installed and uses that information during setup to configure the hardware. ServerGuide simplifies the operating-system installations by providing updated device drivers and, in some cases, installing them automatically.

When using ServerGuide to deploy Windows 2008 series, ServerGuide might run into a blue screen on your system with or without ServeRAID C110 enabled. To avoid this problem, do the following:

1. Set UEFI settings.
2. View the **Device and I/O Ports** setting.
3. Do one of the following and save the changes:
 - If the ServeRAID C110 is enabled, change the **onboard SATA ports as** into **RAID** or **IDE**.
 - If the ServeRAID C110 is not enabled, change the **onboard SATA ports as** into **IDE**.

After saving the settings, the system will return to normal when rebooting from ServerGuide.

You can download a free image of the *ServerGuide Setup and Installation CD* from:
<http://www.ibm.com/support/entry/portal/docdisplay?Indocid=SERV-GUIDE>

In addition to the *ServerGuide Setup and Installation CD*, you must have your operating-system disc to install the operating system.

ServerGuide features

Available features might vary slightly with different versions of the ServerGuide program. To learn more about the version that you have, start the *ServerGuide Setup and Installation CD* and read the online overview. Not all features are supported on all server models.

The ServerGuide program has the following features:

- An easy-to-use interface
- Diskette-free setup, and configuration programs that are based on the detected hardware
- Device drivers that are provided for the server model and detected hardware
- Selectable operating-system partition size and file-system type during setup
- Online readme file with links to tips for your hardware and operating-system installation
- Setting system date and time

Setup and configuration overview

You can use the *ServerGuide Setup and Installation CD* to configure any supported Lenovo server model. The setup program provides a list of tasks that are required to set up your server model. On a server with a ServeRAID adapter or SAS/SATA controller with RAID capabilities, you can run the SAS/SATA RAID configuration program to create logical drives.

Typical operating-system installation by using ServerGuide

This section details the ServerGuide typical operating-system installation.

The ServerGuide program can reduce the time for installing an operating system. It provides the device drivers that are required for your hardware and for the operating system that you are installing. Refer to the following list for a typical operating-system installation by using ServerGuide:

1. After you have completed the setup process, the operating-system installation program starts. (You need your operating-system disc to complete the installation.)
2. The ServerGuide program stores information about the server model, service processor, hard disk drive controllers, and Ethernet controllers. Then, the program checks the CD for any updated device drivers. This information is stored and then passed to the operating-system installation program.
3. The ServerGuide program presents operating-system partition options that are based on your operating-system selection and the installed hard disk drives.
4. The ServerGuide program prompts you to insert your operating-system CD and restart the server. At this point, the installation program for the operating system takes control to complete the installation.

Operating-system installation without using ServerGuide

If you have already configured the server hardware and you are not using the ServerGuide program to install your operating system, you can download operating-system installation instructions for the server from <http://www.lenovo.com/support>.

Using the Setup Utility program

Use the Unified Extensible Firmware Interface (UEFI) Setup Utility program to perform the following tasks:

- View configuration information.
- View and change assignments for devices and I/O ports.

- Set the date and time.
- Set and change passwords.
- Set the startup characteristics of the server and the order of startup devices.
- Set and change settings for advanced hardware features.
- View, set, and change settings for power-management features.
- View and clear error logs.
- Change interrupt request (IRQ) settings.
- Resolve configuration conflicts.

Starting the Setup Utility program

To start the Setup Utility program, do the following:

Step 1. Turn on the server.

Note: Approximately 20 seconds after the server is connected to power, the power-control button becomes active.

Step 2. When the prompt **<F1> Setup** is displayed, press F1. If you have set an administrator password, you must type the administrator password to access the full Setup Utility menu. If you do not type the administrator password, a limited Setup Utility menu is available.

Step 3. Select settings to view or change according to your needs.

Setup Utility menu choices

Use the Setup Utility main menu to view and configure the server settings.

The following choices are on the Setup Utility main menu for the UEFI. Depending on the version of the firmware, some menu choices might differ slightly from these descriptions.

- **System Information** (available on the full Setup Utility menu only)

Select this choice to view information about the server. When you make changes through other choices in the Setup Utility, some of those changes are reflected in the system information; you cannot change settings directly in the system information.

- **System Summary**

Select this choice to view configuration information, including the ID, speed, and cache size of the microprocessors; machine type and model of the server; the serial number, the system UUID; and the amount of installed memory. When you make configuration changes through other options in Setup Utility, the changes are reflected in the system summary; you cannot change settings directly in the system summary.

- **Product Data** (available on the full Setup Utility menu only)

Select this choice to view the system-board identifier, the revision level or issue date of the firmware, the Integrated Management Module II (IMM2) and diagnostics code, and the version and date.

- **System Settings**

Select this choice to view or change the server component settings.

- **Adapters and UEFI Drivers**

Select this choice to view information about the UEFI 1.10 and UEFI 2.0 compliant adapters and drivers installed in the server.

- **Processors**

Select this choice to view or change the processor settings.

- **Memory**
Select this choice to view or change the memory settings.
- **Devices and I/O Ports**
Select this choice to view or change assignments for devices and input/output (I/O) ports. You can configure the serial ports and remote console redirection. You also can enable or disable integrated Ethernet controllers, the SAS/SATA controllers, SATA optical drive channels, PCI slots, and video controller. If you disable a device, it cannot be configured, and the operating system will not be able to detect it (this is equivalent to disconnecting the device).
- **Operating Modes**
Select this choice to view or change the operating profile (performance and power utilization).
- **Legacy Support**
Select this choice to view or set the legacy support.
 - **Force Legacy Video on Boot**
Select this choice to force INT video support, if the operating system does not support UEFI video output standards.
 - **Rehook INT 19h**
Select this choice to enable or disable devices from taking control of the boot process. The default setting is **Disable**.
 - **Legacy Thunk Support**
Select this choice to enable or disable UEFI to interact with PCI mass storage devices that are non-UEFI compliant. The default is **Enable**.
 - **Infinite Boot Retry**
Select this choice to enable or disable UEFI to retry the legacy boot order infinitely. The default is **Disable**.
 - **Non-Planar PXE**
Select this choice to enable or disable non-system-board Preboot Execution Environment (PXE) for legacy mode.
 - **BBS Boot**
Select this choice to enable or disable legacy boot in BIOS Boot Specification (BBS) manner. The default is **Enable**.
- **System Security**
Select this choice to view or configure the Trusted Platform Module (TPM) support.
- **Integrated Management Module II (IMM2)**
Select this choice to view or change the settings for the Integrated Management Module II (IMM2).
 - **Power Restore Policy**
Select this choice to set the mode of operation after power loss.
 - **Commands on USB Interface**
Select this choice to enable or disable the Ethernet over USB interface on IMM2. The default is **Enable**.
 - **Network Configuration**
Select this choice to view the system management network interface port, the IMM2 MAC address, the current IMM2 IP address, and host name; define the static IMM2 IP address, subnet mask, and gateway address; specify whether to use the static IP address or have DHCP assign the IMM2 IP address; save the network changes; and reset the IMM2.

- **Reset IMM2 to Defaults**
Select this choice to view or reset the IMM2 to the default settings.
- **Reset IMM2**
Select this choice to reset IMM2.
- **Recovery and RAS**
Select this choice to view or change the POST attempts and system recovery settings.
 - **POST Attempts**
Select this choice to view or change the number of attempts to POST.
 - **POST Attempts Limit**
Select this choice to view or change the Nx boot failure parameters.
 - **System Recovery**
Select this choice to view or change system recovery settings.
 - **POST Watchdog Timer**
Select this choice to view or enable the POST watchdog timer.
 - **POST Watchdog Timer Value**
Select this choice to view or set the POST loader watchdog timer value.
 - **Reboot System on NMI**
Select this choice to enable or disable restarting the system whenever a nonmaskable interrupt (NMI) occurs. The default is **Enable**.
- **Storage**
Select this choice to view or change the storage device settings.
- **Network**
Select this choice to view or change the network device options, such as iSCSI.
- **Drive Health**
Select this choice to view the status of the controllers installed in the blade server.
- **Date and Time** (available on the full Setup Utility menu only)
Select this choice to set the date and time in the server, in 24-hour format (*hour:minute:second*).
- **Start Options** (available on the full Setup Utility menu only)
Select this choice to view or change the start options, including the startup sequence, keyboard NumLock state, PXE boot option, and PCI device boot priority. Changes in the startup options take effect when you start the server.

The startup sequence specifies the order in which the server checks devices to find a boot record. The server starts from the first boot record that it finds. If the server has Wake on LAN hardware and software and the operating system supports Wake on LAN functions, you can specify a startup sequence for the Wake on LAN functions. For example, you can define a startup sequence that checks for a disc in the CD-RW/DVD drive, then checks the hard disk drive, and then checks a Ethernet controller.
- **Boot Manager**
Select this choice to view, add, delete, or change the device boot priority, boot from a file, select a one-time boot, or reset the boot order to the default setting.
- **System Event Log** (available on the full Setup Utility menu only)
Select this choice to enter the System Event Manager, where you can view the POST event log and the system-event log. You can use the arrow keys to move between pages in the error log.
POST event log contains the most recent error codes and messages that were generated during the POST.

System-event log contains POST and system management interrupt (SMI) events and all events that are generated by the baseboard management controller that is embedded in the Integrated Management Module II (IMM2).

Important: If the system-error LED on the front of the server is lit but there are no other error indications, clear the system-event log. Also, after you complete a repair or correct an error, clear the system-event log to turn off the system-error LED on the front of the server.

- **POST Event Viewer**

Select this choice to enter the POST event viewer to view the POST error messages.

- **System Event Log**

Select this choice to view the system event log.

- **Clear System Event Log**

Select this choice to clear the system event log.

- **User Security**

Select this choice to set, change, or clear passwords. For more information, see “Passwords” on page 32.

- **Set Power-on Password**

Select this choice to set or change a power-on password. For more information, see “Power-on password” on page 33.

- **Clear Power-on Password**

Select this choice to clear a power-on password. For more information, see “Power-on password” on page 33.

- **Set Administrator Password**

Select this choice to set or change an administrator password. An administrator password is intended to be used by a system administrator; it limits access to the full Setup Utility menu. If an administrator password is set, the full Setup Utility menu is available only if you type the administrator password at the password prompt. For more information, see “Administrator password” on page 33.

- **Clear Administrator Password**

Select this choice to clear an administrator password. For more information, see “Administrator password” on page 33.

- **Save Settings**

Select this choice to save the changes that you have made in Setup Utility.

- **Restore Settings**

Select this choice to cancel the changes that you have made in Setup Utility and restore the previous settings.

- **Load Default Settings**

Select this choice to cancel the changes that you have made in Setup Utility and restore the factory settings.

- **Exit Setup**

Select this choice to exit Setup Utility. If you have not saved the changes that you have made in Setup Utility, you will be asked whether you want to save the changes or exit without saving them.

Passwords

From the **User Security** menu choice, you can set, change, and delete a power-on password and an administrator password.

The **User Security** menu choice is on the full Setup Utility menu only.

If you set only a power-on password, you must type the power-on password to complete the system startup and to have access to the full Setup Utility menu.

An administrator password is intended to be used by a system administrator; it limits access to the full Setup Utility menu. If you set only an administrator password, you do not have to type a password to complete the system startup, but you must type the administrator password to access the Setup Utility menu.

If you set a power-on password for a user and an administrator password for a system administrator, you must type the power-on password to complete the system startup. A system administrator who types the administrator password has access to the full Setup Utility menu; the system administrator can give the user authority to set, change, and delete the power-on password. A user who types the power-on password has access to only the limited Setup Utility menu; the user can set, change, and delete the power-on password, if the system administrator has given the user that authority.

Power-on password

If a power-on password is set, when you turn on the server, you must type the power-on password to complete the system startup. You can use any combination of 6-20 printable ASCII characters for the password.

When a power-on password is set, you can enable the Unattended Start mode, in which the keyboard and mouse remain locked but the operating system can start. You can unlock the keyboard and mouse by typing the power-on password.

If you forget the power-on password, you can regain access to the server in any of the following ways:

- If an administrator password is set, type the administrator password at the password prompt. Start the Setup Utility and reset the power-on password.

Attention: If you set an administrator password and then forget it, there is no way to change, override, or remove it. You must replace the system board.

- Remove the battery from the server, wait 30 seconds, and then reinstall it.
- Change the position of the power-on password switch by enabling switch 2 of the system board switch block (SW1) to bypass the password check (see “System-board switches and jumpers” on page 22 for more information).

Attention: Before you change any switch settings or move any jumpers, turn off the server; then, disconnect all power cords and external cables. For the safety information, see “Safety” on page v. Do not change settings or move jumpers on any system-board switch or jumper blocks that are not shown in this document.

The default position for all switches on the switch block SW1 is Off.

While the server is turned off, move switch 2 of the switch block SW1 to the On position to enable the power-on password override. You can then start the Setup Utility and reset the power-on password. You do not have to return the switch to the previous position.

The power-on password override switch does not affect the administrator password.

Administrator password

If an administrator password is set, you must type the administrator password for access to the full Setup Utility menu. You can use any combination of 6-20 printable ASCII characters for the password.

Attention: If you set an administrator password and then forget it, there is no way to change, override, or remove it. You must replace the system board.

Using the Boot Manager program

Boot Manager is a built-in, menu-driven configuration program that you can use to temporarily redefine the first startup device without changing settings in Setup Utility.

To use the Boot Manager program, do the following:

- Step 1. Turn off the server.
- Step 2. Restart the server.
- Step 3. When the prompt <F12> Select Boot Device is displayed, press F12.
- Step 4. Use the Up arrow and Down arrow keys to select an item from the menu and press Enter.

The next time the server starts, it returns to the startup sequence that is set in the Setup Utility.

Starting the backup server firmware

The system board contains a backup copy area for the server firmware. During the process of updating the server firmware, if the primary copy of the server firmware becomes damaged, use this backup copy.

To force the server to start from the backup copy, turn off the server; then, place the UEFI boot backup jumper in the backup position (pins 2 and 3) to enable the UEFI recovery mode. For the location of the UEFI boot backup jumper, see “System-board switches and jumpers” on page 22.

Use the backup copy of the server firmware until the primary copy is restored. After the primary copy is restored, turn off the server; then, move the UEFI boot backup jumper back to the primary position (pins 1 and 2).

UpdateXpress System Pack Installer

The UpdateXpress System Pack Installer detects supported and installed device drivers and firmware in the server and installs available updates.

For additional information and to download the UpdateXpress System Pack Installer, go to the ToolsCenter for System x and BladeCenter at <http://publib.boulder.ibm.com/infocenter/toolsctr/v1r0/> and click **UpdateXpress System Pack Installer**.

Changing the Power Policy option to the default settings after loading UEFI defaults

The default settings for the Power Policy option are set by the IMM2.

To change the Power Policy option to the default settings, do the following:

- Step 1. Turn on the server.

Note: Approximately 20 seconds after the server is connected to ac power, the power-control button becomes active.

- Step 2. When the prompt <F1> Setup is displayed, press F1. If you have set an administrator password, you must type the administrator password to access the full Setup Utility menu; otherwise if you do not type the administrator password, a limited Setup Utility menu is available.

- Step 3. Select **System Settings** → **Integrated Management Module**, and then set **Power Restore Policy** setting to **Restore**.

- Step 4. Go back to **System Configuration and Boot Management** → **Save Settings**.

Step 5. Go back and check the **Power Policy** setting to verify that it is set to **Restore** (the default).

Using the Integrated Management Module II (IMM2)

Integrated Management Module II (IMM2) is a second generation of the functions that were formerly provided by the baseboard management controller hardware. It combines service processor functions, video controller, and remote presence function in a single chip.

IMM2 supports the following basic system-management features:

- Alerts (in-band and out-of-band alerting, PET traps - IPMI style, SNMP, e-mail)
- Auto Boot Failure Recovery (ABR)
- Automatic Server Restart (ASR) when POST is not completed or the operating system hangs and the operating system watchdog timer times out
- A virtual media key, which enables remote presence support (remote video, remote keyboard/mouse, and remote storage)
- Boot sequence manipulation
- Command-line interface
- Configurations save and restore
- DIMM error assistance. The UEFI disables a failing DIMM that is detected during POST, and the IMM2 lights the associated system error LED
- Environmental monitor with fan speed control for temperature, voltages, fan failure, power supply failure, and power backplane failure
- Intelligent Platform Management Interface (IPMI) Specification V2.0 and Intelligent Platform Management Bus (IPMB) support
- Invalid system configuration (CONFIG) LED support
- Local firmware code flash update
- Nonmaskable interrupt (NMI) detection and reporting
- Operating-system failure blue screen capture
- PCI configuration data
- Power/reset control (power-on, hard and soft shutdown, hard and soft reset, schedule power control)
- Query power-supply input power
- ROM-based IMM2 firmware flash updates
- Serial over LAN (SOL)
- Serial port redirection over telnet or ssh protocols
- SMI handling
- System event log (SEL) - user readable event log

The IMM2 also provides the following remote server management capabilities through the ipmitool, a management utility program:

- **Command-line interface (IPMI Shell)**

The command-line interface provides direct access to server management functions through the IPMI 2.0 protocol. Use the command-line interface to issue commands to control the server power, view system information, and identify the server. You can also save one or more commands as a text file and run the file as a script.

- **Serial over LAN**

Establish a Serial over LAN (SOL) connection to manage servers from a remote location. You can remotely view and change the UEFI settings, restart the server, identify the server, and perform other management functions. Any standard telnet client application can access the SOL connection.

For more information about IMM2, see the *Integrated Management Module II User's Guide* at: http://publib.boulder.ibm.com/infocenter/systemx/documentation/topic/com.lenovo.sysx.imm2.doc/product_page.html

Using the remote presence and blue-screen capture features

The remote presence and blue-screen capture features are integrated in the Integrated Management Module II (IMM2).

The remote presence feature provides the following functions:

- Remotely viewing video with graphics resolutions up to 1600 x 1200 at 75 Hz, regardless of the system state
- Remotely accessing the server, using the keyboard and mouse from a remote client
- Mapping the CD or DVD drive, and USB flash drive on a remote client, and mapping ISO image files as virtual drives that are available for use by the server

The blue-screen capture feature captures the video display contents before the IMM2 restarts the server when the IMM2 detects an operating-system hang condition. A system administrator can use the blue-screen capture to assist in determining the cause of the hang condition.

Obtaining the IMM2 host name

If you are logging on to the IMM2 for the first time after installation, the IMM2 defaults to DHCP. If a DHCP server is not available, the IMM2 uses a static IP address of 192.168.70.125. The default IPv4 host name is "IMM-" (plus the last 12 characters on the IMM2 MAC address). The default host name also comes on the IMM2 network access tag, which is attached to the power supply on the rear of the server. You can get the host name without starting the server.

The IPv6 link-local address (LLA) is derived from the IMM2 default host name. To derive the link-local address, do the following:

- Step 1. Take the last 12 characters on the IMM2 MAC address (for example, 5CF3FC5EAAD0).
- Step 2. Separate the number into pairs of hexadecimal characters (for example, 5C:F3:FC:5E:AA:D0).
- Step 3. Separate the first six and last six hexadecimal characters.
- Step 4. Add "FF" and "FE" in the middle of the 12 characters (for example, 5C F3 FC FF FE 5E AA D0).
- Step 5. Convert the first pair of hexadecimal characters to binary (for example, 5=0101, C=1100, which results in 01011100 F3 FC FF FE 5E AA D0).
- Step 6. Flip the seventh binary character from left (0 to 1 or 1 to 0), which results in 01011110 F3 FF FE 5E AA D0.
- Step 7. Convert the binary back to hexadecimal (for example, 5E F3FCFFFE5EAAD0).

Obtaining the IP address for the IMM2

To access the Web interface to use the remote presence feature, you need the IP address or host name of the IMM2. You can obtain the IMM2 IP address through the Setup Utility and you can obtain the IMM2 host name from the IMM2 network access tag. The server comes with a default IP address (192.168.70.125) for the IMM2.

To obtain the IP address, do the following:

Step 1. Turn off the server.

Note: Approximately 20 seconds after the server is connected to power, the power-control button becomes active.

Step 2. When the prompt <F1> Setup is displayed, press F1. (This prompt is displayed on the screen for only a few seconds. You must press F1 quickly.) If you have set both a power-on password and an administrator password, you must type the administrator password to access the full Setup Utility menu.

Step 3. Select **System Settings** from the Setup Utility main menu.

Step 4. Select **Integrated Management Module**.

Step 5. Select **Network Configuration**.

Step 6. Find the IP address and write it down.

Step 7. Exit Setup Utility.

Logging in to the Web interface

To log in to the IMM2 Web interface, do the following:

Step 1. On a system that is connected to the server, open a Web browser. In the **Address** or **URL** field, type the IP address or host name of the IMM2 to which you want to connect.

Note: If you are logging on to the IMM2 for the first time after installation, the IMM2 defaults to DHCP. If a DHCP host is not available, the IMM2 assigns a static IP address of 192.168.70.125. The IMM2 network access tag provides the default host name of the IMM2 and does not require you to start the server.

Step 2. On the Login page, type the user name and password. If you are using the IMM2 for the first time, you can obtain the user name and password from your system administrator. All login attempts are documented in the system-event log.

Note: The IMM2 is set initially with a user name of USERID and password of PASSWORD (with a zero, not the letter O). You have read and write access. You must change the default password the first time you log in.

Step 3. Click **Log in** to start the session. The System Status and Health page provides a quick view of the system status.

Note: If you boot to the operating system while in the IMM2 GUI and the message “Booting OS or in unsupported OS” is displayed under **System Status** → **System State**, disable Windows 2008 or 2012 firewall or type the following command in the Windows Server® 2008 or 2012 console. This might also affect blue-screen capture features.

```
netsh advfirewall firewall set icmpsetting type=8 mode=ENABLE
```

By default, the icmp packet is blocked by Windows Server firewall. The IMM2 GUI will then change to the “OS booted” status after you change the setting as indicated above in both the Web and CLI interfaces.

Using the embedded hypervisor

The VMware ESXi embedded hypervisor is available on the optional Lenovo USB flash device.

The USB flash device can be connected to the USB connectors on the system board. To locate the connectors, see “System-board connectors” on page 21. Hypervisor is a type of software that enables multiple operating systems to run on a host system at the same time. The USB flash device is required to activate the hypervisor.

To start using the embedded hypervisor, you must add the USB flash device to the startup sequence in the Setup Utility.

To add the USB flash device to the startup sequence, do the following:

Step 1. Turn on the server.

Note: Approximately 20 seconds after the server is connected to power, the power-control button becomes active.

Step 2. When the prompt <F1> Setup is displayed, press F1.

Step 3. From the Setup Utility main menu, select **Boot Manager**.

Step 4. Select **Add Boot Option**; then, select **Generic Boot Option → Embedded Hypervisor**. Press Enter, and then press Esc.

Step 5. Select **Change Boot Order → Change the order**. Use the up and down arrow keys to select **Embedded Hypervisor** and use the plus (+) and minus (-) keys to move Embedded Hypervisor in the boot order. When **Embedded Hypervisor** is in the correct location in the boot order, press Enter. Select **Commit Changes** and press Enter.

Step 6. Select **Save Settings** and then select **Exit Setup**.

If the embedded hypervisor flash device image becomes corrupt, you can download the image from <https://my.vmware.com/web/vmware/downloads>.

For more information, see the VMware vSphere Documentation at http://www.vmware.com/support/pubs/vs_pages/vsp_pubs_esxi41_e_vc41.html or the *VMware vSphere Installation and Setup Guide* at <http://pubs.vmware.com/vsphere-50/topic/com.vmware.ICbase/PDF/vsphere-esxi-vcenter-server-50-installation-setup-guide.pdf>.

Ethernet controller information

The Ethernet controllers are integrated on the system board. They provide an interface for connecting to a 10 Mbps, 100 Mbps, or 1 Gbps network and provide full-duplex (FDX) capability, which enables simultaneous transmission and reception of data on the network. If the Ethernet connectors in the server support auto-negotiation, the controllers detect the data-transfer rate (10BASE-T, 100BASE-TX, or 1000BASE-T) and duplex mode (full-duplex or half-duplex) of the network and automatically operate at that rate and mode.

You do not have to set any jumpers or configure the controllers. However, you must install a device driver to enable the operating system to address the controllers.

To find device drivers, go to <http://www.lenovo.com/support>.

Enabling Features on Demand Ethernet and Demand RAID software

You can activate the Features on Demand (FoD) software upgrade key for the following:

- Fibre Channel over Ethernet (FCoE)
- iSCSI storage protocol
- RAID

The FCoE and iSCSI storage protocols and RAID are integrated in the IMM2.

For more information, see the *Lenovo Features on Demand User's Guide*. To download the document, go to <http://www.ibm.com/systems/x/fod/>, log in, and click **Help**.

Accessing RAID configuration utility

Through the Setup Utility, you can access utilities to configure RAID arrays.

The specific procedure for configuring arrays depends on the RAID card that you are using. For details, see the documentation for your RAID card. To access the utility for your RAID card, do the following:

Step 1. Turn on the server.

Note: Approximately 20 seconds after the server is connected to power, the power-control button becomes active.

Step 2. When prompted, <F1 Setup> is displayed, press F1. If you have set an administrator password, you must type the administrator password to access the full Setup Utility menu. If you do not type the administrator password, a limited Setup Utility menu is available.

Step 3. Select **System Settings → Storage**.

Step 4. Select the device driver for your RAID card and press Enter. Then, follow the instructions in the documentation for your RAID card.

Lenovo ToolsCenter Suite CLI program

The Lenovo ToolsCenter Suite CLI program is a collection of server management tools and the program also covers the configuration function, which is an alternative to the Setup Utility for modifying UEFI settings.

Lenovo ToolsCenter Suite CLI has the following features:

- Utilizing a command-line interface to manage firmware, hardware, and operating systems
- Modifying UEFI settings from the command line without restarting the system to access the Setup Utility
- Configuring the optional remote presence features or other IMM2 settings
- Providing IMM2 LAN over USB interface configuration and issuing setup commands through the command-line interface
- Scripting environments through a batch-processing mode
- Saving any of the settings as a file and running the file as a script

For more information and to download Lenovo ToolsCenter Suite CLI, go to <https://support.lenovo.com/us/en/documents/LNVO-CENTER>.

Using Lenovo XClarity Administrator

The initial setup of Lenovo XClarity Administrator includes the following:

- Preparing the network
- Installing and configuring the Lenovo XClarity Administrator virtual appliance
- Managing systems
- Setting up automatic problem notification optionally

To manage systems based on the network topology that is implemented in your environment, there are a number of different ways to connect manageable systems to the network and to set up the Lenovo XClarity Administrator. If you plan to use Lenovo XClarity Administrator to manage the server, you must check for the latest applicable Lenovo XClarity Administrator updates. For installing the Lenovo XClarity Administrator in VMware ESXi-based and Hyper-V environments and downloading Lenovo XClarity Administrator updates, go to:

<https://support.lenovo.com/us/en/documents/LNVO-XCLARIT>

Lenovo XClarity Administrator offers a free, 90-day trial license that enables you to use all available features (including operating-system deployment, firmware maintenance, and configuration management) for a limited time. To continue using Lenovo XClarity Administrator after the 90-day trial period, you are required to purchase a full-function-enablement license for each Lenovo XClarity Administrator instance. You can purchase and download the license from:

<https://www-947.ibm.com/support/entry/portal/docdisplay?Indocid=LNVO-XCLAREF>

Updating the Universal Unique Identifier (UUID)

The Universal Unique Identifier (UUID) must be updated when the system board is replaced. Use the Lenovo ToolsCenter Suite CLI to update the UUID in the UEFI-based server.

Lenovo ToolsCenter Suite CLI is an online tool that supports several operating systems. Make sure that you download the version for your operating system. You can download Lenovo ToolsCenter Suite CLI from the Lenovo Web site. To download Lenovo ToolsCenter Suite CLI and update the UUID, do the following:

Note: Changes are made periodically to the Lenovo Web site. The actual procedure might vary slightly from what is described in this document.

Step 1. Download Lenovo ToolsCenter Suite CLI:

- a. Go to <http://www.lenovo.com/support>.
- b. Click the **Downloads** tab at the top of the panel.
- c. Under **ToolsCenter**, select **View ToolsCenter downloads**.
- d. Select **Lenovo ToolsCenter Suite CLI**.
- e. Scroll down, click the link, and download the Lenovo ToolsCenter Suite CLI version for your operating system.

Step 2. Lenovo ToolsCenter Suite CLI sets the UUID in the Integrated Management Module II (IMM2). Select one of the following methods to access the Integrated Management Module II (IMM2) to set the UUID:

- Online from the target system, such as LAN or keyboard console style (KCS) access
- Remote access to the target system (LAN based)
- Bootable medium containing Lenovo ToolsCenter Suite CLI (LAN or KCS, depending upon the bootable media)

Step 3. Copy and unpack the Lenovo ToolsCenter Suite CLI package, which also includes other required files, to the server. Make sure that you unpack the Lenovo ToolsCenter Suite CLI and the required files to the same directory.

Step 4. After you install Lenovo ToolsCenter Suite CLI, use the following command syntax to set the UUID:

```
onecli config set SYSTEM_PROD_DATA.SysInfoUUID <uuid_value> [access_method]
```

Where:

<uuid_value>

Up to 16-byte hexadecimal value assigned by you.

[access_method]

The access method that you selected to use from the following methods:

- Online authenticated LAN access, type the command:

```
[--imm imm_user_id:imm_password@imm_internal_ip]
```

Where:

imm_internal_ip

The IMM2 internal LAN/USB IP address. The default value is 169.254.95.118.

imm_user_id

The IMM2 account (1 of 12 accounts). The default value is USERID.

imm_password

The IMM2 account password (1 of 12 accounts). The default value is PASSWORD (with a zero 0 not an O).

Note: If you do not specify any of these parameters, Lenovo ToolsCenter Suite CLI will use the default values. When the default values are used and Lenovo ToolsCenter Suite CLI is unable to access the IMM2 using the online authenticated LAN access method, Lenovo ToolsCenter Suite CLI will automatically use the unauthenticated KCS access method.

Example that does not use the user ID and password default values:
onecli config set SYSTEM_PROD_DATA.SysInfoUUID <uuid_value> -user <user_id>
-password <password>

Example that uses the user ID and password default values:
onecli config set SYSTEM_PROD_DATA.SysInfoUUID <uuid_value>

- Online KCS access (unauthenticated and user restricted):

You do not need to specify a value for *access_method* when you use this access method.

Example:

```
onecli config set SYSTEM_PROD_DATA.SysInfoUUID <uuid_value>
```

The KCS access method uses the IPMI/KCS interface. This method requires that the IPMI driver be installed. Some operating systems have the IPMI driver installed by default. Lenovo ToolsCenter Suite CLI provides the corresponding mapping layer. For more details, see the *Lenovo ToolsCenter Suite CLI Users Guide*. To access this guide, do the following:

1. Go to <http://www.lenovo.com/support>.
 2. Click the **Downloads** tab at the top of the panel.
 3. Under **ToolsCenter**, select **View ToolsCenter downloads**.
 4. Select **Lenovo ToolsCenter Suite CLI**.
 5. Scroll down and click the link and download the Lenovo ToolsCenter Suite CLI version for your operating system. Scroll down and look under **Online Help** to download the *Lenovo ToolsCenter Suite CLI Users Guide*.
- Remote LAN access, type the command:

Note: When using the remote LAN access method to access IMM2 using the LAN from a client, the *host* and the *imm_external_ip* address are required parameters.

```
[--imm imm_user_id:imm_password@imm_external_ip]
```

Where:

imm_external_ip

The external IMM2 LAN IP address. There is no default value. This parameter is required.

imm_user_id

The IMM2 account (1 of 12 accounts). The default value is USERID.

imm_password

The IMM2 account password (1 of 12 accounts). The default value is PASSWORD (with a zero 0 not an O).

Example that does not use the user ID and password default values:
onecli config set SYSTEM_PROD_DATA.SysInfoUUID <uuid_value> [--imm imm_user_id:imm_password@imm_internal_ip]

Example that does use the user ID and password default values:
onecli config set SYSTEM_PROD_DATA.SysInfoUUID <uuid_value>

- Bootable media:

You can also build a bootable medium using the applications available through the ToolsCenter Web site at <https://support.lenovo.com/us/en/documents/LNVO-CENTER>. From the **ToolsCenter** page, scroll down for the available tools.

Step 5. Restart the server.

Updating the DMI/SMBIOS data

The Desktop Management Interface (DMI) must be updated when the system board is replaced. Use the Lenovo ToolsCenter Suite CLI to update the DMI in the UEFI-based server. Lenovo ToolsCenter Suite CLI is an online tool that supports several operating systems. Make sure that you download the version for your operating system. You can download Lenovo ToolsCenter Suite CLI from the Lenovo Web site. To download Lenovo ToolsCenter Suite CLI and update the DMI, do the following:

Note: Changes are made periodically to the Lenovo Web site. The actual procedure might vary slightly from what is described in this document.

Step 1. Go to <https://support.lenovo.com/us/en/documents/LNVO-TCLI>. Then, find and download the Lenovo ToolsCenter Suite CLI version for your operating system.

Step 2. Lenovo ToolsCenter Suite CLI sets the DMI in the Integrated Management Module II (IMM2). Select one of the following methods to access the Integrated Management Module II (IMM2) to set the DMI:

- Online from the target system, such as LAN or keyboard console style (KCS) access
- Remote access to the target system (LAN based)
- Bootable medium containing the Lenovo ToolsCenter Suite CLI (LAN or KCS, depending upon the bootable media)

Step 3. Copy and unpack the Lenovo ToolsCenter Suite CLI package, which also includes other required files, to the server. Make sure that you unpack the Lenovo ToolsCenter Suite CLI and the required files to the same directory. In addition to the application executable (Lenovo ToolsCenter Suite CLI or Lenovo ToolsCenter Suite CLI64), the following files are required:

- For Windows based operating systems:
 - *ibm_rndis_server_os.inf*
 - *device.cat*
- For Linux based operating systems:
 - *cdc_interface.sh*

Step 4. After you install Lenovo ToolsCenter Suite CLI, type the following commands to set the DMI:

```
onecli config set SYSTEM_PROD_DATA.SysInfoProdName <m/t_model> [access_method]
onecli config set SYSTEM_PROD_DATA.SysInfoSerialNum <s/n> [access_method]
onecli config set SYSTEM_PROD_DATA.SysEncloseAssetTag <asset_tag> [access_method]
```

Where:

<m/t_model>

The server machine type and model number. Type mtm xxxxyyy, where xxxx is the machine type and yyy is the server model number.

<s/n>

The serial number on the server. Type sn zzzzzzz, where zzzzzzz is the serial number.

<asset_method>

The server asset tag number. Type asset aaaaaaaaaaaaaaaaaaaaaaaaaaaaaa, where aaaaaaaaaaaaaaaaaaaaaaaaaaaaaa is the asset tag number.

[access_method]

The access method that you select to use from the following methods:

- Online authenticated LAN access, type the command: [--imm imm_user_id:imm_password@imm_internal_ip]

Where:

imm_internal_ip

The IMM2 internal LAN/USB IP address. The default value is 169.254.95.118.

imm_user_id

The IMM2 account (1 of 12 accounts). The default value is USERID.

imm_password

The IMM2 account password (1 of 12 accounts). The default value is PASSWORD (with a zero 0 not an O).

Note: If you do not specify any of these parameters, Lenovo ToolsCenter Suite CLI will use the default values. When the default values are used and Lenovo ToolsCenter Suite CLI is unable to access the IMM2 using the online authenticated LAN access method, Lenovo ToolsCenter Suite CLI will automatically use the unauthenticated KCS access method.

Examples that do use the user ID and password default values:

```
onecli config set SYSTEM_PROD_DATA.SysInfoProdName <m/t_model>
onecli config set SYSTEM_PROD_DATA.SysInfoSerialNum <s/n>
onecli config set SYSTEM_PROD_DATA.SysEncloseAssetTag <asset_tag>
```

- Online KCS access (unauthenticated and user restricted): You do not need to specify a value for *access_method* when you use this access method.

The KCS access method uses the IPMI/KCS interface. This method requires that the IPMI driver be installed. Some operating systems have the IPMI driver installed by default. Lenovo ToolsCenter Suite CLI provides the corresponding mapping layer. To download the *Lenovo ToolsCenter Suite CLI Users Guide*, do the following:

1. Go to <http://www.lenovo.com/support>.
2. Click **Downloads** tab at the top of the panel.
3. Under **ToolsCenter**, select **View ToolsCenter downloads**.
4. Select **Lenovo ToolsCenter Suite CLI**.
5. Scroll down and click the link and download the Lenovo ToolsCenter Suite CLI version for your operating system. Scroll down and look under **Online Help** to download the *Lenovo ToolsCenter Suite CLI Users Guide*.

The following commands are examples of not using the user ID and password default values:

```
onecli config set SYSTEM_PROD_DATA.SysInfoProdName <m/t_model>
onecli config set SYSTEM_PROD_DATA.SysInfoSerialNum <s/n>
onecli config set SYSTEM_PROD_DATA.SysEncloseAssetTag <asset_tag>
```

- Remote LAN access, type the command:

Note: When using the remote LAN access method to access IMM2 using the LAN from a client, the *host* and the *imm_external_ip* address are required parameters.

```
[--imm imm_user_id:imm_password@imm_external_ip]
```

Where:

imm_external_ip

The external IMM2 LAN IP address. There is no default value. This parameter is required.

imm_user_id

The IMM2 account (1 of 12 accounts). The default value is USERID.

imm_password

The IMM2 account password (1 of 12 accounts). The default value is PASSWORD (with a zero 0 not an O).

Examples that do use the user ID and password default values:

```
onecli config set SYSTEM_PROD_DATA.SysInfoProdName <m/t_model> -host <imm_ip>
```

```
onecli config set SYSTEM_PROD_DATA.SysInfoSerialNum <s/n> -host <imm_ip>
```

```
onecli config set SYSTEM_PROD_DATA.SysEncloseAssetTag <asset_tag> -host <imm_ip>
```

- Bootable media:

You can also build a bootable medium using the applications available through the ToolsCenter Web site at <https://support.lenovo.com/us/en/documents/LNVO-CENTER>. From the **ToolsCenter** page, scroll down for the available tools.

Step 5. Restart the server.

Configuring onboard SATA software RAID

You can configure onboard SATA software RAID by enabling the onboard SATA RAID functionality, creating RAID volumes, deleting RAID volumes, and marking disks as spare.

Enabling the onboard SATA RAID functionality

Note: Use the arrow keys on the keyboard to make selections.

To enable onboard SATA RAID functionality, do the following:

1. Start the Setup Utility program. See “Starting the Setup Utility program” on page 29.
2. Select **System settings** → **Devices and I/O prots**.
3. Select **Onboard SATA mode** and press Enter.
4. Select **RAID** and press Enter.
5. Press ESC twice to return to the main menu of the Setup Utility program.
6. Select **Save Settings** and press Enter.
7. Exit the Setup Utility program.

Creating RAID volumes

This section describes how to use the Intel Rapid Storage Technology enterprise UEFI HII to create RAID volumes.

To create RAID volumes, do the following:

1. Start the Setup Utility program. See “Starting the Setup Utility program” on page 29.
2. Select **System settings** → **Storage** and press Enter.
3. Select **Intel RSTe SATA Controller** and press Enter.
4. Select **Create RAID Volume** and press Enter.
5. Type a proper RAID volume name in the **Name** field and press Enter.
6. Use the arrow keys to select a RAID level in the **RAID Level** field and press Enter.
7. Use the arrow keys to select a hard disk drive in the **Select Disk** field and press Enter.

8. If necessary, repeat step 7 to select multiple hard disk drives.
9. Use the arrow keys to select a stripe size in the **Stripe Size** field and press Enter.
10. Type a volume size in the **Capacity (MB)** field and press Enter.
11. Select **Create Volume** and press Enter.
12. When prompted, press Y to accept the warning message and create the volume.
13. If desired, return to step 4 to create additional RAID volumes.

Deleting RAID volumes

This section describes how to use the Intel Rapid Storage Technology enterprise UEFI HII to delete RAID volumes.

To delete RAID volumes, do the following:

1. Start the Setup Utility program. See “Starting the Setup Utility program” on page 29.
2. Select **System settings** → **Storage** and press Enter.
3. Select **Intel RSTe SATA Controller** and press Enter.
4. Use the arrow keys to select the RAID volume to be deleted in the **RAID Volume** field and press Enter.
5. Select **Delete** and press Enter.
6. When prompted, press Y to confirm the deletion of the selected RAID volume. Deleting a RAID volume will reset the hard disk drives to non-RAID.
7. After deleting a RAID volume, you can:
 - Return to step 4 to delete additional RAID volumes.
 - See “Creating RAID volumes” on page 44 for RAID volume creation.
 - Exit the Setup Utility program.

Marking disks as spare

To mark hard disk drives as spare drives, do the following:

1. Start the Setup Utility program. See “Starting the Setup Utility program” on page 29.
2. Select **System settings** → **Storage** and press Enter.
3. Select **Intel RSTe SATA Controller** and press Enter.
4. Use the up and down arrow keys to select a Non-RAID physical disk in the **Non-RAID Physical Disks** field and press Enter.
5. Select **Mark as Spare** and press Enter.
6. When prompted, press Y to confirm the operation.

Note: Marking a hard disk drive as a spare drive will remove all data on the drive.

Notes: If your server has one of the following Linux operating systems installed, continue with the corresponding actions:

- For the Redhat Enterprise Linux 6.7 operating system, add the following line to the end of the `/etc/mdadm.conf` file and restart the operating system.
`POLICY domain=DOMAIN path=* metadata=imsm action=spare-same-slot`
- For the SUSE Linux Enterprise Server 11.4 operating system, do the following:
 1. Add the following line to the end of the `/etc/mdadm.conf` file.
`POLICY domain=DOMAIN path=* metadata=imsm action=spare-same-slot`
 2. Run the following commands as a root user.
`# chkconfig -s mdadm on`
`# /etc/init.d/mdadm start`

Chapter 5. Troubleshooting

This chapter describes the diagnostic tools and troubleshooting information that are available to help you solve problems that might occur in the server.

If you cannot diagnose and correct a problem by using the information in this chapter, see Appendix D “Getting help and technical assistance” on page 661.

Start here

You can solve many problems without outside assistance by following the troubleshooting procedures in this documentation and on the World Wide Web.

This document describes the diagnostic tests that you can perform, troubleshooting procedures, and error messages and error codes. The documentation that comes with your operating system and software also contains troubleshooting information.

Diagnosing a problem

Before you contact IBM or a Lenovo-approved warranty service provider, perform the following steps in the order in which they are presented to diagnose a problem with your server.

Step 1. **Return the server to the condition it was in before the problem occurred.**

If any hardware, software, or firmware was changed before the problem occurred, if possible, reverse those changes. This action might involve any of the following items:

- Hardware components
- Device drivers and firmware
- System software
- UEFI firmware
- System input power or network connections

Step 2. **View the light path diagnostics LEDs, event logs, and error codes.** The following items are available to help you diagnose hardware and software problems easily:

- **Light path diagnostics LEDs** (see “Light path diagnostics” on page 53)
- **Event logs** (see “Event logs” on page 56)
- **Software or operating-system error codes** (see the documentation or tips on the manufacturer's Web site)

Step 3. **Run Lenovo Dynamic System Analysis (DSA) and collect the system data.**

Run Dynamic System Analysis (DSA) to collect information about the hardware, firmware, software, and operating system. Have this information available when you contact IBM or an approved warranty service provider. For instructions on how to run DSA, see the *Dynamic System Analysis Installation and User's Guide*.

To download the latest version of DSA code and the *Dynamic System Analysis Installation and User's Guide*, go to <https://support.lenovo.com/us/en/documents/LNVO-DSA>.

Step 4. **Check for and apply code updates.**

Fixes or workarounds for many problems might be available in updated UEFI firmware, device firmware, or device drivers. To display a list of available updates for the server, go to <http://www.ibm.com/support/fixcentral>.

Attention: Installing the wrong firmware or device-driver update might cause the server to malfunction. Before you install a firmware or device-driver update, read any readme and change history files that are provided with the downloaded update. These files contain important information about the update and the procedure for installing the update, including any special procedure for updating from an early firmware or device-driver version to the latest version.

Important: Some cluster solutions require specific code levels or coordinated code updates. If the device is part of a cluster solution, verify that the latest level of code is supported for the cluster solution before you update the code.

a. **Install UpdateXpress system updates.**

You can install code updates that are packaged as an UpdateXpress System Pack or UpdateXpress CD image. An UpdateXpress System Pack contains an integration-tested bundle of online firmware and device-driver updates for your server. In addition, you can use Lenovo ToolsCenter Bootable Media Creator to create bootable media that is suitable for applying firmware updates and running preboot diagnostics. For more information about UpdateXpress System Packs, go to:

<http://www.ibm.com/support/entry/portal/docdisplay?lnocid=SERV-XPRESS> For more information about the Bootable Media Creator program, go to:
<https://support.lenovo.com/us/en/documents/LNVO-BOMC>

Be sure to separately install any listed critical updates that have a release date later than the release date of the UpdateXpress System Pack or UpdateXpress image. Refer to the following two steps for installing manual system updates.

b. **Install manual system updates.**

1. **Determine the existing code levels.**

In DSA, click **Firmware/VPD** to view system firmware levels, or click **Software** to view operating-system levels.

2. **Download and install updates for any code that is not at the latest level.**

To display a list of available updates for the server, go to <http://www.ibm.com/support/fixcentral>.

When you click an update, an information page is displayed, including a list of the problems that the update fixes. Review this list for your specific problem; however, even if your problem is not listed, installing the update might solve the problem.

Step 5. **Check for and correct an incorrect configuration.**

If the server is incorrectly configured, a system function can fail to work when you enable it; if you make an incorrect change to the server configuration, a system function that has been enabled can stop working.

a. **Make sure that all installed hardware and software are supported.**

To verify that the server supports the installed operating system, optional devices, and software levels, go to <http://www.lenovo.com/serverproven/>. If any hardware or software component is not supported, remove the hardware or uninstall the software to determine whether it is causing the problem. You must remove nonsupported hardware before you contact IBM or an approved warranty service provider for support.

b. **Make sure that the server, operating system, and software are installed and configured correctly.**

Many configuration problems are caused by loose power or signal cables or improperly seated adapters. You might be able to solve the problem by turning off the server, reconnecting cables, reseating adapters, and turning the server back on. For information about performing the checkout procedure, see “Precautions before performing the checkout procedure” on page 50. For information about configuring the server, see Chapter 4 “Configuration information” on page 25.

Step 6. Consult the controller and management software documentation.

If the problem is associated with a specific function (for example, if a RAID hard disk drive is marked offline in the RAID array), see the documentation for the associated controller and management or controlling software to verify that the controller is correctly configured.

Problem determination information is available for many devices such as RAID and Ethernet controllers.

For problems with operating systems or IBM software or devices, go to <http://www.lenovo.com/support>.

Step 7. Check for troubleshooting procedures and retain tips.

Troubleshooting procedures and retain tips document known problems and suggested solutions. To search for troubleshooting procedures and retain tips, go to <http://www.lenovo.com/support>.

Step 8. Use the troubleshooting tables.

To find a solution to a problem that has identifiable symptoms, see “Troubleshooting by symptom” on page 61.

A single problem might cause multiple symptoms. Follow the troubleshooting procedure for the most obvious symptom. If that procedure does not solve the problem, use the procedure for another symptom, if possible.

If the problem remains, contact IBM or an approved warranty service provider for assistance with additional problem determination and possible hardware replacement. To open an online service request, go to http://www.ibm.com/support/entry/portal/Open_service_request. Be prepared to provide information about any error codes and collected data.

Opening an online service request

If you have completed the diagnostic procedure and the problem remains, the problem might not have been previously identified by IBM. After you have verified that all codes are at the latest level, all hardware and software configurations are valid, and no light path diagnostics LEDs or log entries indicate a hardware component failure, contact IBM or an approved warranty service provider for assistance.

To open an online service request, go to http://www.ibm.com/support/entry/portal/Open_service_request. Be prepared to provide information about any error codes and collected data and the problem determination procedures that you have used.

Service bulletins

Lenovo continually updates the support Web site with the latest tips and techniques that you can use to solve problem that you might have with the Lenovo System x3250 M6 server.

To find service bulletins that are available for the Lenovo System x3250 M6 server, go to <http://www.lenovo.com/support> and search for 3633 and 3943, and retain.

Checkout procedure

This section provides additional information for you to diagnose a problem.

Precautions before performing the checkout procedure

Before you perform the checkout procedure for diagnosing hardware problems, review the following information.

- Read the safety information. See “Safety” on page v.
- Dynamic System Analysis (DSA) provides the primary methods of testing the major components of the server, such as the system board, Ethernet controller, keyboard, mouse (pointing device), serial ports, and hard disk drives. You can also use DSA to test some external devices. If you are not sure whether a problem is caused by the hardware or by the software, you can use DSA to confirm that the hardware is working properly.
- When you run DSA, a single problem might cause more than one error message. When this happens, correct the cause of the first error message. The other error messages usually will not occur the next time you run DSA.

Important: If multiple error codes or light path diagnostics LEDs indicate a microprocessor error, the error might be related to the microprocessor or the microprocessor socket.

- Before you run DSA, you must determine whether the failing server is part of a shared hard disk drive cluster (two or more servers sharing external storage devices). If it is part of a cluster, you can run all diagnostic programs except the ones that test the storage unit (that is, a hard disk drive in the storage unit) or the storage adapter that is attached to the storage unit. The failing server might be part of a cluster if any of the following conditions is true:
 - You have identified the failing server as part of a cluster (two or more servers sharing external storage devices).
 - One or more external storage units are attached to the failing server and at least one of the attached storage units is also attached to another server or unidentifiable device.
 - One or more servers are located near the failing server.

Important: If the server is part of a shared HDD cluster, run one test at a time. Do not run any suite of tests, such as “quick” or “normal” tests, because this might enable the hard disk drive diagnostic tests.

- If the server is halted and a POST error code is displayed, see Appendix B “UEFI (POST) error codes” on page 491. If the server is halted and no error message is displayed, see “Troubleshooting by symptom” on page 61 and “Solving undetermined problems” on page 72.
- For information about power-supply problems, see “Solving power problems” on page 71, “Power problems” on page 69, and “Power-supply LEDs” on page 54.
- For intermittent problems, check the event log; see “Event logs” on page 56 and Appendix C “DSA diagnostic test results” on page 503.

Performing the checkout procedure

To perform the checkout procedure, do the following:

Step 1. Is the server part of a cluster?

- **No:** Go to Step 2 on page 50.
- **Yes:** Shut down all failing servers that are related to the cluster. Go to Step 3 on page 51.

Step 2. Do the following:

- a. Check the power supply LEDs. See “Power-supply LEDs” on page 54.
- b. Turn off the server and all external devices.
- c. Check all internal and external devices for compatibility at <http://www.lenovo.com/serverproven/>.
- d. Check all cables and power cords.
- e. Set all display controls to the middle positions.
- f. Turn on all external devices.
- g. Turn on the server. If the server does not start, see “Troubleshooting by symptom” on page 61.
- h. Check the system-error LED on the operator information panel. If it is lit, check the light path diagnostics LEDs. See “Light path diagnostics” on page 53.
- i. Check for the following results:
 - Successful completion of the POST. (see “POST” on page 58)
 - Successful completion of startup, which is indicated by a readable display of the operating-system desktop

Step 3. Is there a readable image on the monitor screen?

- **No:** Find the failure symptom in “Troubleshooting by symptom” on page 61; if necessary, see “Solving undetermined problems” on page 72.
- **Yes:** Run DSA. See “Running DSA Preboot diagnostic program” on page 59.
 - If DSA reports an error, follow the instructions in Appendix C “DSA diagnostic test results” on page 503.
 - If DSA does not report an error but you still suspect a problem, see “Solving undetermined problems” on page 72.

Diagnostic tools

The following tools are available to help you diagnose and solve hardware-related problems.

- **Light path diagnostics**

Use light path diagnostics to diagnose system errors quickly. For more information, see “Light path diagnostics” on page 53.

- **Event logs**

The event logs list the error codes and messages that are generated when an error is detected. For more information, see “Event logs” on page 56.

- **Integrated Management Module II (IMM2)**

The Integrated Management Module II (IMM2) combines service processor functions, video controller, and remote presence and blue-screen capture features in a single chip. The IMM2 provides advanced service-processor control, monitoring, and alerting function. If an environmental condition exceeds a threshold or if a system component fails, the IMM2 lights LEDs to help you diagnose the problem, records the error in the IMM2 event log, and alerts you to the problem. Optionally, the IMM2 also provides a virtual presence capability for remote server management capabilities. The IMM2 provides remote server management through the following industry-standard interfaces:

- Intelligent Platform Management Protocol (IPMI) version 2.0
- Simple Network Management Protocol (SNMP) version 3
- Common Information Model (CIM)
- Web browser

For more information about the Integrated Management Module II (IMM2), see “Using the Integrated Management Module II (IMM2)” on page 35, Appendix A “Integrated Management Module II (IMM2) error messages” on page 175, and the *Integrated Management Module II User's Guide* at http://publib.boulder.ibm.com/infocenter/systemx/documentation/topic/com.lenovo.sysx.imm2.doc/product_page.html.

- **Dynamic System Analysis Preboot (DSA Preboot)**

The DSA Preboot diagnostic program is stored in the integrated USB memory on the server. DSA Preboot collects and analyzes system information to aid in diagnosing server problems, as well as offering a rich set of diagnostic tests for the major server components. DSA Preboot collects the following information about the server:

- Drive health information
- IMM2 configuration information
- IMM2 environmental information
- Installed hardware, including PCI and USB information
- Light path diagnostics status
- Microprocessor, input/output hub, and UEFI error logs
- Network interfaces and settings
- Option card driver and firmware information
- RAID controller configuration
- Service processor (Integrated Management Module II (IMM2)) status and configuration
- System configuration
- Vital product data, firmware, and UEFI configuration

DSA Preboot also provides diagnostics for the following system components (when they are installed):

- Emulex Ethernet controller
- IMM2 I2C bus
- Light path diagnostics panel
- Memory modules
- Microprocessors
- Optical devices (CD or DVD)
- SAS or SATA drives
- LSI controller
- Broadcom Ethernet controller
- FusionIO storage
- Intel GPU
- NVIDIA GPU

For more information about running DSA Preboot on the server, see “Running DSA Preboot diagnostic program” on page 59.

You can also diagnose and solve problems by symptom. For more information, see “Troubleshooting by symptom” on page 61.

- Follow the suggested actions in the order in which they are listed in the Action column until the problem is solved.

- If an action step is preceded by '(Trained technician only)', that step must be performed only by a trained technician.
- Go to the Lenovo support Web site at <http://www.lenovo.com/support> to check for technical information, hints, tips, and new device drivers or to submit a request for information.

Light path diagnostics

Light path diagnostics is a system of LEDs on various external and internal components of the server that leads you to the failed component. When an error occurs, LEDs are lit along the path of the front panel, the operator information panel, then on the failed component. By viewing the LEDs in a particular order, you can often identify the source of the error.



When LEDs are lit to indicate an error, they remain lit when the server is turned off, if the server is still connected to power and the power supply is operating correctly.

Before you work inside the server to view light path diagnostics LEDs, read the safety information “Safety” on page v and “Handling static-sensitive devices” on page 88.

If an error occurs, view the light path diagnostics LEDs and look at the operator information panel on the front of the server.

The following table describes the LEDs on the operator information panel and suggested actions to correct the detected problems.

Table 5. Light path diagnostics: LED status and actions

LED	Description	Action
System-locator LED  (blue)	This LED is used as a presence detection LED. You can use Systems Director or IMM2 to light this LED remotely.	Use this LED to locate the server among other servers visually.
Check log LED  (amber)	LED on: An error has occurred and cannot be isolated without performing certain procedures.	<ol style="list-style-type: none"> 1. Check the IMM2 event log and the system-error log for information about the error. 2. Save the log if necessary and clear the log afterward.
System-error LED  (amber)	LED on: An error has occurred.	<ol style="list-style-type: none"> 1. Check the system-locator LED and check log LED and follow the instructions. 2. Check the IMM2 event log and the system-error log for information about the error. 3. Save the log if necessary and clear the log afterward.

Error LEDs

This section describes the error LEDs on the system board and the suggested actions to correct the detected problems.

The system board has error LEDs that will help to locate the source of the error. Run the diagnostic programs to find out the cause of the error. See “Dynamic System Analysis” on page 58.

The server is designed so that LEDs remain lit when the server is connected to an ac power source but is not turned on, provided that the power supply is operating correctly. This feature helps you to isolate the problem when the operating system is shut down.

Note: When you disconnect the power source from the server, you lose the ability to view the LEDs because the LEDs are not lit when the power source is removed. Before you disconnect the power source, make a note of which LEDs are lit, including the LEDs that are lit on the operation information panel and LEDs inside the server on the system board.

Many errors are first indicated by the lit system-error LED on the operator information panel of the server. If this LED is lit, one or more LEDs elsewhere in the server might also be lit and can direct you to the source of the error.

Before you work inside the server to view the LEDs, read the “Safety” on page v and “Handling static-sensitive devices” on page 88.

If an error occurs or you suspect a system error, do the following:

1. Check the operator information panel on the front of the server. If the system-error LED is lit, it confirms that an error has occurred.
2. Check the IMM2 event log and the system-error log for information about the error.
3. Look at the system service label inside the cover of the server, which gives an overview of internal components. This label also usually includes helpful instructions to help you correct the error.

For the locations of the error LEDs, see “System-board LEDs” on page 24.

The following table describes the LEDs on the system board and suggested actions to correct the detected problems:

- IMM2 heartbeat LED: When the server is connected to power, this LED flashes quickly to indicate that the IMM2 code is loading. When the loading is completed, the LED stops flashing quickly and then flashes slowly, which means that the IMM2 is fully operational and you can press the power-control button to start the server.

If the LED does not begin flashing within 30 seconds after the server is connected to power, do the following:

1. (Trained technician only) Recover the firmware. See “Recovering the server firmware (UEFI update failure)” on page 74.
 2. (Trained technician only) Replace the system board.
- System-error LED: When the LED is lit, it indicates that the microprocessor VRD and/or power voltage regulators have failed. Then, you need to ask trained technician to replace the system board.
 - CPLD heartbeat LED: If the LED flashes at 1 Hz, it is functioning properly and no action is necessary. If the LED is not flashing, replace the system board (Trained technician only).

Power-supply LEDs

This section describes the power-supply LEDs on the rear of the server and the suggested actions to correct the detected problems.

The following minimum configuration is required for the server to start:

- One microprocessor
- One 4 GB DIMM
- Power supply
- Power cord
- Four cooling fans

For the locations of the LEDs and connectors on the rear of the server, see “Rear view” on page 17.

The following table describes the problems that are indicated by various combinations of the power-supply LEDs and suggested actions to correct the detected problems.

Table 6. Power-supply LEDs

ac power LED	dc power LED	Power-supply error LED	Description	Action
On	On	Off	Normal operation	No action needed.
Off	Off	Off	No ac power to the server or a problem with the ac power source. This symptom is a normal condition when no ac power is present.	<ol style="list-style-type: none"> 1. Check the ac power to the server. 2. Make sure that the power cord is connected to a functioning power source. 3. Restart the server. If the error remains, check the power-supply LEDs. 4. If the problem remains, replace the power-supply.
On	Off	Off	Faulty system board or faulty power supply The symptom typically indicates that a power supply is not fully seated. This is a normal condition before turning on the system.	<ol style="list-style-type: none"> 1. Turn off the server and disconnect the power cord from the server; then, reconnect the power cord. 2. If the system board error (fault) LED is not lit, replace the power supply. 3. (Trained technician only) If the system board error LED is lit, replace the system board.
On	Off or Flashing	On	Faulty power supply	Replace the power supply.
On	On	On	Power supply is faulty but still operational.	Replace the power supply.

System pulse LEDs

This section describes the system pulse LEDs on the system board that monitors the system power-on and power-off and boot progress.

The following LEDs are on the system board and monitor the system power-on and power-off sequencing and boot progress. For the location of these LEDs, see “System-board LEDs” on page 24.

CPLD heartbeat LED: If the LED flashes at 1 Hz, it is functioning properly and no action is necessary. If the LED is not flashing, replace the system board (Trained technician only).

IMM2 heartbeat LED: The LED status shows the following different stages of the IMM2 heartbeat sequencing process:

1. When this LED is blinking fast (approximately 4 Hz), this indicates that the IMM2 code is in the loading process.
2. When this LED goes off momentarily, this indicates that the IMM2 code has loaded completely.
3. When this LED goes off momentarily and then starts blinking slowly (approximately 1 Hz), this indicates that IMM2 is fully operational. You can now press the power-control button to power on the server.

4. (Trained technician only) If this LED does not blink within 30 seconds of connecting a power source to the server, replace the system board.

Event logs

Error codes and messages are recorded in various event logs, including the POST event log, system-event log, Integrated Management Module II (IMM2) event log, and DSA event log.

- **POST event log:** This log contains the most recent error codes and messages that were generated during the POST. You can view the contents of the POST event log from Setup Utility. See “Starting the Setup Utility program” on page 29. For more information about POST error codes, see Appendix B “UEFI (POST) error codes” on page 491.
- **System-event log:** This log contains POST and system management interrupt (SMI) events and all events that are generated by the baseboard management controller that is embedded in the Integrated Management Module II (IMM2). You can view the contents of the system-event log through Setup Utility and through the Dynamic System Analysis (DSA) program (as IPMI event log). The system-event log is limited in size. When it is full, new entries will not overwrite existing entries; therefore, you must periodically clear the system-event log through the Setup Utility. When you are troubleshooting an error, you might have to save and then clear the system-event log to make the most recent events available for analysis. For more information about the system-event log, see Appendix A “Integrated Management Module II (IMM2) error messages” on page 175.

Messages are listed on the left side of the screen, and details about the selected message are displayed on the right side of the screen. To move from one entry to the next, use the up and down arrow keys.

Some IMM2 sensors cause assertion events to be logged when their setpoints are reached. When a setpoint condition no longer exists, a corresponding event is logged. However, not all events are assertion-type events.

- **Integrated Management Module II (IMM2) event log:** This log contains a filtered subset of all IMM2, POST, and system management interrupt (SMI) events. You can view the IMM2 event log through the IMM2 Web interface. For more information, see “Logging in to the Web interface” on page 37. You can also view the IMM2 event log through the Dynamic System Analysis (DSA) program (as the ASM event log). For more information about IMM2 error messages, see Appendix A “Integrated Management Module II (IMM2) error messages” on page 175.
- **DSA event log:** This log is generated by the Dynamic System Analysis (DSA) program, and it is a chronologically ordered merge of the system-event log (as the IPMI event log), the IMM2 chassis-event log (as the ASM event log), and the operating-system event logs. You can view the DSA event log through the DSA program. See “Viewing event logs without restarting the server” on page 57. For more information about DSA and DSA messages, see “Dynamic System Analysis” on page 58 and Appendix C “DSA diagnostic test results” on page 503.

Viewing event logs through Setup Utility

To view the POST event log or system-event log after starting the server, do the following:

- Step 1. Turn on the server.
- Step 2. When the prompt **<F1> Setup** is displayed, press F1. If you have set both a power-on password and an administrator password, you must type the administrator password to view the event logs.
- Step 3. Select **System Event Log** and do one of the following:
 - To view the POST event log, select **POST Event Viewer**.
 - To view the system-event log, select **System Event Log**.

Viewing event logs without restarting the server

If the server is not hung and the IMM2 is connected to a network, methods are available for you to view one or more event logs without having to restart the server.

If you have installed Lenovo ToolsCenter Suite CLI, you can use it to view the system-event log (as the IPMI event log), or the IMM2 event log (as the Chassis event log), the operating-system event logs, or the merged Lenovo ToolsCenter Suite CLI log. You can also use DSA Preboot to view these logs, although you must restart the server. To install Lenovo ToolsCenter Suite CLI or check for and download a later version of Lenovo ToolsCenter Suite CLI image, go to:

<https://support.lenovo.com/us/en/documents/LNVO-CENTER>

If IPMItool is installed in the server, you can use it to view the system-event log. Most recent versions of the Linux operating system come with a latest version of IPMItool. For an overview of IPMI, go to <http://www.ibm.com/developerworks/linux/blueprints/> and click **Using Intelligent Platform Management Interface (IPMI) on Lenovo Linux platforms**.

You can view the IMM2 event log through the **Event Log** link in the Integrated Management Module II (IMM2) Web interface. For more information, see “Logging in to the Web interface” on page 37.

The following table describes the methods that you can use to view the event logs, depending on the condition of the server. The first three conditions generally do not require that you restart the server.

Table 7. Methods for viewing event logs

Condition	Action
The server is not hung and is connected to a network (using an operating system controlled network ports).	Use any of the following methods: <ul style="list-style-type: none">• Run Lenovo ToolsCenter Suite CLI to view the system event log (requires IPMI driver) or create an output file that you can send to Lenovo service and support (using ftp or local copy).• Use IPMItool to view the system-event log (requires the IPMI driver).• Use the Web browser interface to the IMM2 to view the system-event log locally (requires RNDIS USB LAN driver).
The server is not hung and is not connected to a network (using an operating system controlled network ports).	<ul style="list-style-type: none">• Run Lenovo ToolsCenter Suite CLI to view the system event log (requires IPMI driver) or create an output file that you can send to Lenovo service and support (using ftp or local copy).• Use IPMItool to view the system-event log (requires the IPMI driver).• Use the Web browser interface to the IMM2 to view the system-event log locally (requires RNDIS USB LAN driver).
The server is not hung and the Integrated Management Module II (IMM2) is connected to a network.	In a Web browser, type the IP address for the IMM2 and go to the Event Log page. For more information, see “Obtaining the IMM2 host name” on page 36 and “Logging in to the Web interface” on page 37.
The server is hung, and no communication can be made with the IMM2.	<ul style="list-style-type: none">• If DSA Preboot is installed, restart the server and press F2 to start DSA Preboot and view the event logs. For more information, see “Running DSA Preboot diagnostic program” on page 59.• Alternatively, you can restart the server and press F1 to start the Setup Utility and view the POST event log or system-event log. For more information, see “Viewing event logs through Setup Utility” on page 56.

Clearing the event logs

To clear the event logs, do the following:

Note: The POST error log is automatically cleared each time the server restarts.

Step 1. Turn on the server.

- Step 2. When the prompt **<F1> Setup** is displayed, press F1. If you have set both a power-on password and an administrator password, you must type the administrator password to view the event logs.
- Step 3. To clear the IMM2 system-event log, select **System Event Log → Clear System Event Log**, then, press **Enter** twice.

POST

When you turn on the server, it performs a series of tests to check the operation of the server components and some optional devices in the server. This series of tests is called power-on self-test, or POST.

Note: You cannot view the server status through beep codes.

If a power-on password is set, you must type the password when required and then press **Enter** to allow the POST to start running.

If a problem is detected during the POST, an error message is displayed on the screen and also sent to the POST event log. For more information, see Appendix B “UEFI (POST) error codes” on page 491.

If POST detects a problem, an error message is sent to the POST event log. For more information, see “Event logs” on page 56.

Dynamic System Analysis

Dynamic System Analysis (DSA) collects and analyzes system information to aid in diagnosing server problems. Lenovo provides DSA Preboot edition to users.

DSA collects the following information about the server:

- Drive health information
- Event logs for ServeRAID controllers and service processors
- Hardware inventory, including PCI and USB information
- Light path diagnostics status
- Network interfaces and settings
- Performance data and details about processes that are running
- RAID controller configuration
- Service processor (Integrated Management Module II (IMM2)) status and configuration
- System configuration
- Vital product data and firmware information

For system-specific information about the action that you should take as a result of a message that DSA generates, see Appendix C “DSA diagnostic test results” on page 503.

If you cannot find a problem by using DSA, see “Solving undetermined problems” on page 72 for information about testing the server.

Note: DSA Preboot might appear to be unresponsive when you start the program. This is normal symptom while the program loads.

Make sure that the server has the latest version of the DSA code. To obtain DSA codes and the *Dynamic System Analysis Installation and User's Guide*, go to:
<https://support.lenovo.com/us/en/documents/LNVO-DSA>

DSA Preboot

DSA Preboot runs outside of the operating system; you must restart the server to run it. It is provided in the flash memory on the server, or you can create a bootable medium such as a CD or DVD using ToolsCenter Bootable Media Creator (BoMC). For more details, refer to the BoMC user guide. You can download the user guide at:

<https://support.lenovo.com/us/en/documents/LNVO-BOMC>

DSA Preboot includes diagnostic routines that would be disruptive to run within the operating-system environment (such as resetting devices). It has a graphical user interface that you can use to specify which diagnostics to run and to view the diagnostic and data collection results.

DSA Preboot provides diagnostics for the following system components, if they are installed:

- Emulex Ethernet controller
- Optical devices (CD or DVD)
- Tape drives (SCSI, SAS, or SATA)
- Memory
- Microprocessor
- Checkpoint panel
- I2C bus
- SAS and SATA drives

If you are able to restart the server or if you need comprehensive diagnostics, use DSA Preboot.

For more information and to download DSA Preboot, go to:

<https://support.lenovo.com/us/en/documents/LNVO-DSA>

Running DSA Preboot diagnostic program

Note: The DSA memory test might take up to 30 minutes to finish. If the problem is not a memory problem, skip the memory test.

To run the DSA Preboot diagnostic program, do the following:

Step 1. If the server is running, turn off the server and all attached devices.

Step 2. Turn on all attached devices; then, turn on the server.

Step 3. When the prompt **<F2> Diagnostics** is displayed, press F2.

Note: The DSA Preboot diagnostic program might appear to be unresponsive for an unusual length of time when you start the program. This is normal symptom while the program loads. The loading process might take up to 10 minutes.

Step 4. Optionally, select **Quit to DSA** to exit from the stand-alone memory diagnostic program.

Note: After you exit the stand-alone memory diagnostic environment, you must restart the server to access the stand-alone memory diagnostic environment again.

Step 5. Type `gui` to display the graphical user interface, or type `cmd` to display the DSA interactive menu.

Step 6. Follow the instructions on the screen to select the diagnostic tests to run.

If the diagnostic program does not detect any hardware errors but the problem remains during normal server operation, the diagnostic program error might be the cause. If you suspect a diagnostic program error, see the information that comes with your program.

A single problem might cause more than one error message. When this happens, correct the cause of the first error message. The other error messages usually will not occur the next time you run the diagnostic programs.

If the server is hung during testing and you cannot continue, restart the server and try running the DSA Preboot diagnostic programs again. If the problem remains, replace the component that was being tested when the server is hung.

Diagnostic text messages

Diagnostic text messages are displayed while the tests are running.

A diagnostic text message contains one of the following results:

Passed: The test was completed without any errors.

Failed: The test detected an error.

Aborted: The test could not proceed because of the server configuration.

Additional information concerning test failures is available in the extended diagnostic results for each test.

Viewing the test log results and transferring the DSA collection

To view the test log for the results when the tests are completed, do one of the following:

- Click the **Success** link in the Status column, if you are running the DSA graphical user interface.
- Type :x to exit the **Execute Tests** menu, if you are running the DSA interactive menu. Then, select **completed tests** to view the results.
- Select **Diagnostic Event Log** in the graphical user interface.

To transfer DSA Preboot collections to an external USB device, type the `copy` command in the DSA interactive menu.

You can also send the DSA error log to Lenovo service and support to aid in diagnosing the server problems.

Automated service request (call home)

Lenovo provides a tool that can automatically collect and send data or call Lenovo Support when an error is detected.

This tool can help Lenovo Support speed up the process of diagnosing problems.

Electronic Service Agent

Electronic Service Agent™ monitors, tracks, and captures system hardware errors as well as hardware and software inventory information. It also reports serviceable problems directly to Lenovo Support.

Although you can collect these system data manually, Electronic Service Agent could also be a good alternative because it uses minimal system resources and can be easily downloaded from <http://www.ibm.com/support/esa/>.

Error messages

Lenovo provide error messages on the Web site and PDF file. If you are viewing the Web site, the list of error codes and messages for UEFI/POST, IMM2, and DSA that are generated when a problem is detected will display.

If you are viewing PDF file, refer to the following topics:

- Appendix A “Integrated Management Module II (IMM2) error messages” on page 175
- Appendix B “UEFI (POST) error codes” on page 491
- Appendix C “DSA diagnostic test results” on page 503

Troubleshooting by symptom

Use the troubleshooting tables to find solutions to problems that have identifiable symptoms.

If you cannot find a solution to the problem in these tables, see Appendix C “DSA diagnostic test results” on page 503 for information about testing the server and “Running DSA Preboot diagnostic program” on page 59 for additional information about running DSA Preboot program. For additional information to help you solve problems, see “Start here” on page 47.

Notes:

- Follow the suggested actions in the order in which they are listed in the Action column until the problem is solved.
- If an action step is preceded by '(Trained technician only)', that step must be performed only by a trained technician.
- Go to the Lenovo support Web site at <http://www.lenovo.com/support> to check for technical information, hints, tips, and new device drivers or to submit a request for information.

If you have added new software or a new optional device and the server is not working, do the following before you use the troubleshooting tables:

- Step 1. Check the system-error LED on the operator information panel; if it is lit, check the light path diagnostics LEDs (see “Light path diagnostics” on page 53).
- Step 2. Remove the software or device that you just added.
- Step 3. Run Dynamic System Analysis (DSA) to determine whether the server is running properly (see Appendix C “DSA diagnostic test results” on page 503).
- Step 4. Reinstall the new software or new device.

General problems

Table 8. General symptoms and actions

Symptom	Action
A cover latch is broken, an LED is not working, or a similar problem has occurred.	If the part is a CRU, replace it. If the part is a microprocessor or the system board, the part must be replaced by a trained technician.
The server is hung while the screen is on. You cannot start Setup Utility by pressing F1.	See “Nx-boot failure” on page 76 and “Recovering the server firmware (UEFI update failure)” on page 74.

Optical drive problems

Table 9. Optical drive symptoms and actions

Symptom	Action
The optical drive is not recognized.	<ol style="list-style-type: none"> Make sure that: <ul style="list-style-type: none"> The SATA connector to which the optical drive is attached (primary or secondary) is enabled in Setup Utility. All cables and jumpers are installed correctly. The correct device driver is installed for the optical drive. Run the optical drive diagnostic programs. Reseat the following components: <ol style="list-style-type: none"> Optical drive Optical drive cable Replace the components listed in step 3 one at a time, in the order shown, restarting the server each time. (Trained technician only) Replace the system board.
A CD or DVD is not working properly.	<ol style="list-style-type: none"> Clean the CD or DVD. Replace the CD or DVD with new CD or DVD media. Run the optical drive diagnostic programs. Check the connector and signal cable for bent pins or damage. Reseat the optical drive. Replace the optical drive.
The optical drive tray is not working.	<ol style="list-style-type: none"> Make sure that the server is turned on. Insert the end of a straightened paper clip into the manual tray-release hole. Reseat the optical drive. Replace the optical drive.

Hard disk drive problems

Table 10. Hard disk drive symptoms and actions

Symptom	Action
Not all drives are recognized by the hard disk drive diagnostic test.	Remove the drive that is indicated by the diagnostic tests; then, run the hard disk drive diagnostic test again. If the remaining drives are recognized, replace the drive that you removed with a new one.
The server stops responding during the hard disk drive diagnostic test.	Remove the hard disk drive that was being tested when the server stopped responding, and run the diagnostic test again. If the hard disk drive diagnostic test runs successfully, replace the drive that you removed with a new one.
A hard disk drive was not detected while the operating system was being started.	Reseat all hard disk drives and cables; then, run the hard disk drive diagnostic test.
A hard disk drive passes the diagnostic Fixed Disk Test, but the problem remains.	Run the diagnostic SCSI Fixed Disk Test. See "Running DSA Preboot diagnostic program" on page 59. Note: This test is not available on servers that have RAID arrays or servers that have SATA hard disk drives.

Table 10. Hard disk drive symptoms and actions (continued)

Symptom	Action
A hard disk drive has failed, and the associated yellow hard disk drive status LED is lit. (hot-swap hard disk drives)	<ol style="list-style-type: none"> 1. Reconfigure the integrated SAS/SATA controller with RAID capabilities and the devices that are attached to it. 2. Run the DSA disk drive test. See “Dynamic System Analysis” on page 58. 3. If the drive fails the test, replace the drive.
A newly installed hard disk drive is not recognized.	<ol style="list-style-type: none"> 1. Observe the associated yellow hard disk drive status LED. If the LED is lit, it indicates a drive fault. 2. If the LED is lit, remove the drive from the bay, wait 45 seconds, and reinsert the drive, making sure that the drive assembly connects to the hard-disk-drive backplane. 3. Observe the associated green hard disk drive activity LED and the yellow status LED: <ul style="list-style-type: none"> • If the green activity LED is flashing and the yellow status LED is not lit, the drive is recognized by the controller and is working correctly. Run the DSA hard disk drive test to determine whether the drive is detected. • If the green activity LED is flashing and the yellow status LED is flashing slowly, the drive is recognized by the controller and is rebuilding. • If neither LED is lit or flashing, check the hard-disk-drive backplane (go to step 4). • If the green activity LED is flashing and the yellow status LED is lit, replace the drive. If the activity of the LEDs remains the same, go to step 4. If the activity of the LEDs changes, return to step 1. 4. Make sure that the hard-disk-drive backplane is correctly seated. When it is correctly seated, the drive assemblies correctly connect to the backplane without bowing or causing movement of the backplane. 5. Reseat the backplane power cable and repeat steps 1 through 3. 6. Reseat the backplane signal cable and repeat steps 1 through 3. 7. Suspect the backplane signal cable or the backplane: <ul style="list-style-type: none"> • Replace the affected backplane signal cable. • Replace the affected backplane. 8. Run the DSA tests for the SAS/SATA adapter and hard disk drives. See “Dynamic System Analysis” on page 58. <ul style="list-style-type: none"> • If the adapter passes the test but the drives are not recognized, replace the backplane signal cable and run the tests again. • Replace the backplane. • If the adapter fails the test, disconnect the backplane signal cable from the adapter and run the tests again. • If the adapter fails the test, replace the adapter. 9. See “Problem determination tips” on page 73.
Multiple hard disk drives fail.	<p>Make sure that the hard disk drive, RAID card, and server device drivers and firmware are at the latest level.</p> <p>Important: Some cluster solutions require specific code levels or coordinated code updates. If the device is part of a cluster solution, verify that the latest level of code is supported for the cluster solution before you update the code.</p>
Multiple hard disk drives are offline.	<ol style="list-style-type: none"> 1. Review the storage subsystem logs for indications of problems within the storage subsystem, such as backplane or cable problems. 2. See “Problem determination tips” on page 73.

Table 10. Hard disk drive symptoms and actions (continued)

Symptom	Action
A replacement hard disk drive does not rebuild.	<ol style="list-style-type: none"> 1. Make sure that the hard disk drive is recognized by the adapter (the green hard disk drive activity LED is flashing). 2. Review the SAS/SATA RAID adapter documentation to determine the correct configuration parameters and settings.
A green hard disk drive activity LED does not accurately represent the actual state of the associated drive. (hot-swap hard disk drives)	<ol style="list-style-type: none"> 1. If the green hard disk drive activity LED does not flash when the drive is in use, run the DSA disk drive test. See “Dynamic System Analysis” on page 58. 2. Use one of the following procedures: <ul style="list-style-type: none"> • If the drive passes the test, replace the backplane. • If the drive fails the test, replace the drive.
A yellow hard disk drive status LED does not accurately represent the actual state of the associated drive. (hot-swap hard disk drives)	<ol style="list-style-type: none"> 1. If the yellow hard disk drive LED and the RAID card software do not indicate the same status for the drive, do the following: <ol style="list-style-type: none"> a. Turn off the server. b. Reseat the SAS/SATA adapter. c. Reseat the backplane signal cable and power cable. d. Reseat the hard disk drive. e. Turn on the server and observe the activity of the hard disk drive LEDs. 2. See “Problem determination tips” on page 73.

Hypervisor problems

Table 11. Hypervisor symptoms and actions

Symptom	Action
If an optional embedded hypervisor flash device is not listed in the expected boot order, does not appear in the list of boot devices, or a similar problem has occurred.	<ol style="list-style-type: none"> 1. Make sure that the optional embedded hypervisor flash device is selected on the boot manager <F12> Select Boot Device at startup. 2. Make sure that the embedded hypervisor flash device is seated in the connector correctly. See “Removing a USB embedded hypervisor flash device” on page 117 and “Installing a USB embedded hypervisor flash device” on page 118. 3. See the documentation that comes with the optional embedded hypervisor flash device for setup and configuration information. 4. Make sure that other software works on the server.

Intermittent problems

Table 12. Intermittent problems and actions

Symptom	Action
A problem occurs only occasionally and is difficult to diagnose.	<ol style="list-style-type: none"> 1. Make sure that: <ul style="list-style-type: none"> • All cables and cords are connected securely to the rear of the server and attached devices. • When the server is turned on, air is flowing from the fan grille. If there is no airflow, the fan is not working. This can cause the server to overheat and shut down. 2. Check the system-error log or IMM2 event log. See “Event logs” on page 56.

Keyboard, mouse, or USB-device problems

Table 13. Keyboard, mouse, or USB-device symptoms and actions

Symptom	Action
All or some keys on the keyboard do not work.	<ol style="list-style-type: none"> 1. Make sure that: <ul style="list-style-type: none"> • The keyboard cable is securely connected. • The server and the monitor are turned on. 2. Run the Setup Utility and enable the USB device option. 3. If the keyboard is connected to a USB hub, disconnect the keyboard from the hub and connect it directly to the server. 4. Replace the keyboard.
The mouse or USB-device does not work.	<ol style="list-style-type: none"> 1. Make sure that: <ul style="list-style-type: none"> • The mouse or USB device cable is securely connected to the server. • The mouse or USB device drivers are installed correctly. • The server and the monitor are turned on. • The mouse option is enabled in the Setup Utility. 2. If you are using a USB mouse or USB device and it is connected to a USB hub, disconnect the mouse or USB device from the hub and connect it directly to the server. 3. Replace the mouse or USB device.

Memory problems

Note: Each time you install or remove a DIMM, you must disconnect the server from the power source; then, wait 10 seconds before restarting the server.

Table 14. Memory problems and actions

Symptom	Action
The amount of system memory that is displayed in Setup Utility is less than the amount of installed physical memory.	<ol style="list-style-type: none"> 1. Make sure that: <ul style="list-style-type: none"> • No error LEDs are lit on the operator information panel. • No DIMM error LEDs are lit on the system board. • The memory modules are seated correctly. • You have installed the correct type of memory. • If you changed the memory, you updated the memory configuration in the Setup Utility. • All banks of memory are enabled. The server might have automatically disabled a memory bank when it detected a problem, or a memory bank might have been manually disabled. • There is no memory mismatch when the server is at the minimum memory configuration. 2. Reseat the DIMMs, and then restart the server. 3. Check the POST error log: <ul style="list-style-type: none"> • If a DIMM was disabled by a system-management interrupt (SMI), replace the DIMM. • If a DIMM was disabled by the user or by the POST, reseat the DIMM; then, run the Setup Utility and enable the DIMM. 4. Check that all DIMMs are initialized in the Setup Utility; then, run memory diagnostics. See “Running DSA Preboot diagnostic program” on page 59.

Table 14. Memory problems and actions (continued)

Symptom	Action
	<ol style="list-style-type: none"> 5. Add one pair of DIMMs at a time, making sure that the DIMMs in each pair match. 6. Reseat the DIMM. 7. Re-enable all DIMMs using the Setup Utility, and then restart the server. 8. Replace the following components one at a time, in the order shown, restarting the server each time: <ol style="list-style-type: none"> a. DIMMs b. (Trained technician only) system board
Multiple rows of DIMMs in a branch are identified as failing.	<ol style="list-style-type: none"> 1. Reseat the DIMMs; then, restart the server. 2. Replace the failing DIMM. 3. (Trained technician only) Replace the system board
A memory error occurs indicating that one memory module in a channel is failing.	<p>For example, if you suspect memory module in slot 1 or slot 2 is failing, do the following:</p> <ol style="list-style-type: none"> 1. Exchange memory module in slot 1 with memory module in slot 3. 2. Restart the server. 3. Check whether this error still occurs. <ol style="list-style-type: none"> a. If yes, it means that memory module in slot 2 is failing. Then, replace memory module in slot 2 with a new memory module. b. If no, it means that memory module in slot 1 is failing. Then, replace memory module in slot 1 with a new memory module. <p>For more information, refer to the tip files at: http://www.lenovo.com/support</p>

Monitor problems

Some Lenovo monitors have their own self-tests. If you suspect a problem with your monitor, see the documentation that comes with the monitor for instructions for testing and adjusting the monitor. If you cannot diagnose the problem, call for service.

Table 15. Monitor and video symptoms and actions

Symptom	Action
Testing the monitor.	<ol style="list-style-type: none"> 1. Make sure that the monitor cables are firmly connected. 2. Try using a different monitor on the server, or try using the monitor that is being tested on a different server. 3. Run the diagnostic programs. If the monitor passes the diagnostic programs, the problem might be caused by a video device driver. 4. (Trained technician only) Replace the system board.
The screen is blank.	<ol style="list-style-type: none"> 1. If the server is attached to a KVM switch, bypass the KVM switch to eliminate it as a possible cause of the problem: connect the monitor cable directly to the correct connector on the rear of the server. 2. Make sure that: <ul style="list-style-type: none"> • The server is turned on. If there is no power to the server, see “Power problems” on page 69. • The monitor cables are connected correctly. • The monitor is turned on and the brightness and contrast controls are adjusted correctly. • No POST errors are generated when the server is turned on.

Table 15. Monitor and video symptoms and actions (continued)

Symptom	Action
	<ol style="list-style-type: none"> 3. Make sure that the correct server is controlling the monitor, if applicable. 4. Make sure that damaged server firmware is not affecting the video. See “Updating the firmware” on page 25. 5. Observe the checkpoint LEDs on the system board; if the codes are changing, go to the next step. 6. Replace the following components one at a time, in the order shown, restarting the server each time: <ol style="list-style-type: none"> a. Monitor b. Video adapter (if one is installed) c. (Trained technician only) System board
<p>The monitor works when you turn on the server, but the screen goes blank when you start some application programs.</p>	<ol style="list-style-type: none"> 1. Make sure that: <ul style="list-style-type: none"> • The application program is not setting a display mode that is higher than the capability of the monitor. • You installed the necessary device drivers for the application. 2. Run video diagnostics. See “Running DSA Preboot diagnostic program” on page 59. <ul style="list-style-type: none"> • If the server passes the video diagnostics, the video is good. Then, you can refer to “Solving undetermined problems” on page 72. • (Trained technician only) If the server fails the video diagnostics, replace the system board.
<p>The monitor has screen jitter, or the screen image is wavy, unreadable, rolling, or distorted.</p>	<ol style="list-style-type: none"> 1. If the monitor self-tests show that the monitor is working properly, consider the location of the monitor. Magnetic fields around other devices (such as transformers, appliances, fluorescents, and other monitors) can cause screen jitter or wavy, unreadable, rolling, or distorted screen images. If this happens, turn off the monitor. <p>Attention: Moving a color monitor while it is turned on might cause screen discoloration.</p> <p>Move the device and the monitor at least 305 mm (12 inches.) apart, and turn on the monitor.</p> <p>Note: Non-Lenovo monitor cables might cause unpredictable problems.</p> 2. Reseat the monitor and cable. 3. Replace the following components one at a time, in the order shown, restarting the server each time: <ol style="list-style-type: none"> a. Monitor b. (Trained technician only) System board
<p>Wrong characters appear on the screen.</p>	<ol style="list-style-type: none"> 1. If the wrong language is displayed, update the server firmware to the latest level (see “Updating the firmware” on page 25) with the correct language. 2. Reseat the monitor and cable. 3. Replace the following components one at a time, in the order shown, restarting the server each time: <ol style="list-style-type: none"> a. Monitor b. (Trained technician only) System board

Network connection problems

Table 16. Network connection problems and actions

Symptom	Action
Login failed by using LDAP account with SSL enabled.	<ol style="list-style-type: none"> 1. Make sure that the license key is valid. 2. Generate a new license key and log in again.

Optional-device problems

Table 17. Optional-device problems and actions

Symptom	Action
A Lenovo optional device that was installed does not work.	<ol style="list-style-type: none"> 1. Make sure that: <ul style="list-style-type: none"> • The device is designed for the server. Go to: http://www.lenovo.com/serverproven/ • You followed the installation instructions that came with the device and the device is installed correctly. • You have not loosened any other installed devices or cables. • You updated the configuration information in the Setup Utility. Whenever memory or any other device is changed, you must update the configuration. 2. Reset the device that you installed. 3. Replace the device that you installed.
A Lenovo optional device that worked previously does not work now.	<ol style="list-style-type: none"> 1. Make sure that all of the cable connections for the device are secure. 2. If the device comes with test instructions, use those instructions to test the device. 3. Reseat the failing device. 4. Replace the failing device.

Operating system boot problem

Table 18. Operating system boot problem and action

Symptom	Action
<p>You cannot boot automatically in the following operating systems:</p> <ul style="list-style-type: none"> • SUSE Linux® Enterprise Server 11 with Service Pack 1 • Red Hat® Enterprise Linux 6 	<p>To recreate the boot entry manually, do the following:</p> <ol style="list-style-type: none"> 1. Turn on the server and press F1 to enter Setup Utility. 2. Select Boot manager. 3. Select Add Boot Option. 4. Select the boot entry with the string "*.efi" 5. Type the description such as "OS_Install". Then, select Commit Changes. <p>For more information, refer to the tip files at: http://www.lenovo.com/support</p>

Power problems

Table 19. Power problems and actions

Symptom	Action
<p>The power-control button does not work, and the reset button does not work (the server does not start).</p> <p>Note: The power-control button will not function until approximately 20 seconds after the server has been connected to power.</p>	<ol style="list-style-type: none"> 1. Disconnect the server power cords. 2. Reconnect the power cords. 3. (Trained technician only) Reseat the operator information panel cable, and then repeat steps 1a and 1b. <ul style="list-style-type: none"> • (Trained technician only) If the server starts, reseat the operator information panel. If the problem remains, replace the operator information panel. • If the server does not start, bypass the power-control button by using the force power-on jumper. See “System-board switches and jumpers” on page 22. If the server starts, reseat the operator information panel. If the problem remains, replace the operator information panel. 4. Make sure that: <ol style="list-style-type: none"> a. The power cords are correctly connected to the server and to a working electrical outlet. b. The type of memory that is installed is correct. c. The DIMM is fully seated. d. The LEDs on the power supply do not indicate a problem. 5. Reseat the following components: <ol style="list-style-type: none"> a. DIMMs b. (Trained technician only) Power-supply cables to all internal components c. (Trained technician only) Power switch connector 6. Replace the following components one at a time, in the order shown, restarting the server each time: <ol style="list-style-type: none"> a. DIMMs b. Power supply c. (Trained technician only) System board 7. If you installed an optional device, remove it, and restart the server. If the server now starts, you might have installed more devices than the total devices that power supply could support. 8. See “Power-supply LEDs” on page 54.
<p>The server does not turn off.</p>	<ol style="list-style-type: none"> 1. Determine whether you are using an Advanced Configuration and Power Interface (ACPI) or a non-ACPI operating system. If you are using a non-ACPI operating system, do the following: <ol style="list-style-type: none"> a. Press Ctrl+Alt+Delete. b. Turn off the server by pressing the power-control button for five seconds. c. Restart the server. d. If the server fails the POST and the power-control button does not work, disconnect the power cord for five seconds; then, reconnect the power cord and restart the server. 2. If the problem remains or if you are using an ACPI-aware operating system, suspect the system board.
<p>The server unexpectedly shuts down, and the LEDs on the operator information panel are not lit.</p>	<p>See “Solving undetermined problems” on page 72.</p>

Serial port problems

Table 20. Serial port problems and actions

Symptom	Action
The number of serial ports that are identified by the operating system is less than the number of installed serial ports.	<ol style="list-style-type: none"> Make sure that: <ul style="list-style-type: none"> Each port is assigned a unique address in the Setup Utility and none of the serial ports are disabled. The serial-port adapter (if one is present) is seated correctly. Reseat the serial port adapter. Replace the serial port adapter.
A serial device does not work.	<ol style="list-style-type: none"> Make sure that: <ul style="list-style-type: none"> The device is compatible with the server. The serial port is enabled and is assigned a unique address. The device is connected to the correct connector. Reseat the following components: <ol style="list-style-type: none"> Failing serial device Serial cable Replace the following components one at a time, in the order shown, restarting the server each time: <ol style="list-style-type: none"> Failing serial device Serial cable (Trained technician only) System board

ServerGuide problems

Table 21. ServerGuide problems and actions

Symptom	Action
The <i>ServerGuide Setup and Installation</i> CD will not start.	<ol style="list-style-type: none"> Make sure that the server supports the ServerGuide program and has a startable (bootable) DVD drive. If the startup (boot) sequence settings have been changed, make sure that the DVD drive is the first in the startup sequence. If more than one DVD drive is installed, make sure that only one drive is set as the primary drive. Start the CD from the primary drive.
The ServeRAID Manager program cannot view all installed drives, or the operating system cannot be installed.	<ol style="list-style-type: none"> Make sure that the hard disk drive is connected correctly. Make sure that the SAS hard disk drive cables are securely connected.
The operating-system installation program continuously loops.	Make more space available on the hard disk.
The ServerGuide program will not start the operating-system CD.	Make sure that the operating-system CD is supported by the ServerGuide program. For a list of supported operating-system versions, go to http://www.ibm.com/support/entry/portal/docdisplay?Indocid=SERV-GUIDE , click the link for your ServerGuide version, and scroll down to the list of supported Microsoft Windows operating systems.
The operating system cannot be installed; the option is not available.	Make sure that the server supports the operating system. If it does, either no logical drive is defined (SCSI RAID servers), or the ServerGuide System Partition is not present. Run the ServerGuide program and make sure that setup is complete.

Software problems

Table 22. Software problems and actions

Symptom	Action
You suspect a software problem.	<ol style="list-style-type: none">1. To determine whether the problem is caused by the software, make sure that:<ul style="list-style-type: none">• The server has the minimum memory that is needed to use the software. For memory requirements, see the information that comes with the software. If you have installed an adapter or a memory module, the server might have a memory-address conflict.• The software is designed to operate on the server.• Other software works on the server.• The software works on another server.2. If you received any error messages when using the software, see the information that comes with the software for a description of the messages and suggested solutions to the problem.3. Contact the software vendor.

USB connector problems

Table 23. USB connector problems and actions

Symptom	Action
A USB device does not work.	<ol style="list-style-type: none">1. Make sure that:<ul style="list-style-type: none">• The correct USB device driver is installed.• The operating system supports USB devices.2. Make sure that the USB configuration options are set correctly in the Setup Utility. For more information, see “Using the Setup Utility program” on page 28.3. If you are using a USB hub, disconnect the USB device from the hub and connect it directly to the server.

Solving power problems

Power problems can be difficult to solve. For example, a short circuit can exist anywhere on any of the power distribution buses. Usually, a short circuit will cause the power subsystem to shut down because of an overcurrent condition. To diagnose a power problem, use the following general procedure:

- Step 1. Turn off the server and disconnect all power cords.
- Step 2. Check for loose cables in the power subsystem. Besides, check for short circuits, for example, if a loose screw is causing a short circuit on a circuit board.
- Step 3. Turn on the server and check the lit LEDs on the system board. See “System-board LEDs” on page 24.
- Step 4. Turn off the server and disconnect all power cords.
- Step 5. Remove the adapters and disconnect the cables and power cords to all internal and external devices until the server is at the minimum configuration that is required for the server to start. See “Solving undetermined problems” on page 72.
- Step 6. Reconnect all ac power cords and turn on the server. If the server starts successfully, turn off the server, reseal the adapters, and then turn on the server. Repeat the operation to reseal other devices one at a time until the problem is isolated.

If the server does not start from the minimum configuration, see “Power-supply LEDs” on page 54 to replace the components in the minimum configuration one at a time until the problem is isolated.

Solving Ethernet controller problems

The method that you use to test the Ethernet controller depends on which operating system you are using. For information about Ethernet controllers, see the Ethernet controller device-driver readme file and the operating-system documentation.

Try the following procedures:

- Step 1. Make sure that the correct device drivers, which come with the server, are installed and that they are at the latest level.
- Step 2. Make sure that the Ethernet cable is installed correctly.
 - The cable must be securely attached at all connections. If the cable is attached but the problem remains, try a different cable.
 - If you set the Ethernet controller to operate at 100 Mbps, you must use Category 5 cabling.
 - If you directly connect two servers (without a hub), or if you are not using a hub with X ports, use a crossover cable. To determine whether a hub has an X port, check the port label. If the label contains an X, the hub has an X port.
- Step 3. Determine whether the hub supports auto-negotiation. If it does not, try configuring the integrated Ethernet controller manually to match the speed and duplex mode of the hub.
- Step 4. Check the Ethernet controller LEDs on the rear panel of the server. These LEDs indicate whether there is a problem with the connector, cable, or hub.
 - The Ethernet link status LED is lit when the Ethernet controller receives a link pulse from the hub. If the LED is off, there might be a defective connector or cable or a problem with the hub.
 - The Ethernet transmit/receive activity LED is lit when the Ethernet controller sends or receives data over the Ethernet network. If the Ethernet transmit/receive activity LED is off, make sure that the hub and network are operating and that the correct device drivers are installed.
- Step 5. Check the LAN activity LED on the rear of the server. The LAN activity LED is lit when data is active on the Ethernet network. If the LAN activity LED is off, make sure that the hub and network are operating and that the correct device drivers are installed.
- Step 6. Check for operating-system-specific causes of the problem.
- Step 7. Make sure that the device drivers on the client and server are using the same protocol.

If the Ethernet controller still cannot connect to the network but the hardware appears to be working, the network administrator must investigate other possible causes of the error.

Solving undetermined problems

If Dynamic System Analysis (DSA) cannot diagnose the failure or if the server is inoperative, use the information in this section to solve the undetermined problems.

If you suspect that a software problem is causing failures (continuous or intermittent), see “Software problems” on page 71.

Corrupted data in CMOS memory or corrupted UEFI firmware can cause undetermined problems. To reset the CMOS data, use the CMOS clear jumper (JP1) to clear the CMOS memory and override the power-on password. See “System-board connectors” on page 21 for more information. If you suspect that the UEFI firmware is corrupted, see “Recovering the server firmware (UEFI update failure)” on page 74.

If the power supplies are working properly, do the following:

- Step 1. Turn off the server.
- Step 2. Make sure that the server is cabled correctly.
- Step 3. Remove or disconnect the following devices, one at a time, until you find the failure. Turn on the server and reconfigure it each time.
- Any external devices (such as printer, mouse, and non-Lenovo devices).
 - Surge-suppressor device (on the server).
 - Each adapter.
 - Hard disk drives.

Note: The minimum configuration required for the server to start is one microprocessor and one 4 GB DIMM.

- Step 4. Turn on the server. If the problem remains, suspect the following components in the following order:
1. Power supply
 2. Memory
 3. Microprocessor
 4. System board

If the problem is solved when you remove an adapter from the server but the problem recurs when you reinstall the same adapter, suspect the adapter; if the problem recurs when you replace the adapter with a different one, suspect the riser card.

If you suspect a networking problem and the server passes all the system tests, suspect a network cabling problem that is external to the server.

Problem determination tips

Because of the variety of hardware and software combinations that can encounter, use the following information to assist you in problem determination. If possible, have this information available when requesting assistance from Lenovo.

The model number and serial number of the server are on the ID label attached on the front bezel.

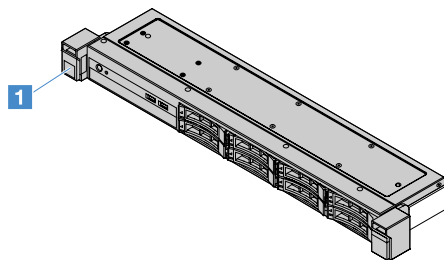

Figure 13. ID label on the front of the server

- Machine type and model
- Microprocessor or hard disk drive upgrades
- Failure symptom
 - Does the server fail the diagnostic tests?
 - What occurs? When? Where?
 - Does the failure occur on a single server or on multiple servers?

- Is the failure repeatable?
- Has this configuration ever worked?
- What changes, if any, were made before the configuration failed?
- Is this the original reported failure?
- Diagnostic program type and version level
- Hardware configuration (print screen of the system summary)
- UEFI firmware level
- IMM firmware level
- Operating system software

You can solve some problems by comparing the configuration and software setups between working and nonworking servers. When you compare servers to each other for diagnostic purposes, consider them identical only if all the following factors are the same in all the servers:

- Machine type and model
- UEFI firmware level
- IMM firmware level
- Adapters and attachments, in the same locations
- Address jumpers, terminators, and cabling
- Software versions and levels
- Diagnostic program type and version level
- Configuration option settings
- Operating-system control-file setup

For information about calling Lenovo for service, see Appendix D “Getting help and technical assistance” on page 661.

Recovering the server firmware (UEFI update failure)

Important: Some cluster solutions require specific code levels or coordinated code updates. If the device is part of a cluster solution, verify that the latest level of code is supported for the cluster solution before you update the code.

If the server firmware has become corrupted, such as from a power failure during an update, you can recover the server firmware in the following ways:

- **In-band method:** Recover server firmware, using either the boot block jumper (Automated Boot Recovery) or a server firmware update package.
- **Out-of-band method:** Use the IMM2 Web interface to update the firmware and the latest server firmware update package.

Note: You can obtain a server-firmware update package through one of the following ways:

- Search and download the update package from <http://www.lenovo.com/support>.
- Contact your Lenovo service representative. Phone numbers are available at <http://www.ibm.com/services> or <http://www.ibm.com/planetwide>.

The flash memory of the server consists of a primary bank and a backup bank. You must maintain a bootable UEFI firmware image in the backup bank. If the server firmware in the primary bank becomes corrupted,

you can manually boot the backup bank with the UEFI boot backup jumper (JP16). In the case of image corruption, this will occur automatically with the Automated Boot Recovery function.

In-band manual recovery method

To recover the server firmware and restore the server operation to the primary bank, do the following:

- Step 1. Read “Safety” on page v and “Before removing or installing server components” on page 87.
- Step 2. Turn off the server, and disconnect all power cords and external cables.
- Step 3. Unlock and remove the server cover. See “Removing the server cover” on page 88.
- Step 4. Locate the UEFI boot backup jumper on the system board. See “System-board switches and jumpers” on page 22.
- Step 5. Move the UEFI boot backup jumper from pins 1 and 2 to pins 2 and 3 to enable the UEFI recovery mode.
- Step 6. Reinstall the server cover; then, reconnect all power cords.
- Step 7. Restart the server. The system begins the power-on self-test (POST).
- Step 8. Boot the server to an operating system that is supported by the firmware update package that you downloaded.
- Step 9. Perform the firmware update by following the instructions that are in the firmware update package readme file.
- Step 10. Turn off the server and disconnect all power cords and external cables, and then remove the server cover. See “Removing the server cover” on page 88.
- Step 11. Move the UEFI boot backup jumper from pins 2 and 3 back to the primary position (pins 1 and 2).
- Step 12. Reinstall the cover. See “Installing the server cover” on page 89.
- Step 13. Reconnect the power cord and any cables that you removed.
- Step 14. Turn on the server. The system begins the power-on self-test (POST). If this does not recover the primary bank, continue with the following steps.
- Step 15. Remove the server cover. See “Removing the server cover” on page 88.
- Step 16. Reset the CMOS by removing the coin-cell battery. See “Removing the coin-cell battery” on page 126.
- Step 17. Leave the coin-cell battery out of the server for approximately 5 to 15 minutes.
- Step 18. Reinstall the coin-cell battery. See “Installing the coin-cell battery” on page 127.
- Step 19. Reinstall the cover. See “Installing the server cover” on page 89.
- Step 20. Reconnect the power cord and any cables that you removed.
- Step 21. Turn on the server. The system begins the power-on self-test (POST).
- Step 22. If these recovery efforts fail, contact your Lenovo service representative for support.

In-band automated boot recovery method

Note: Use this method there is a log entry or Booting Backup Image displayed on the firmware splash screen; otherwise, use the in-band manual recovery method.

Before the automated boot recovery process starts, observe the following:

- Boot the server to an operating system that is supported by the firmware update package that you downloaded.
- Perform the firmware update by following the instructions that are in the firmware update package readme file.

Out-of-band method

See the IMM2 documentation (*Integrated Management Module II User's Guide*) at http://publib.boulder.ibm.com/infocenter/systemx/documentation/topic/com.lenovo.sysx.imm2.doc/product_page.html.

Automated boot recovery (ABR)

While the server is starting, if the integrated management module II detects problems with the server firmware in the primary bank, the server automatically switches to the backup firmware bank and gives you the opportunity to recover the firmware in the primary bank. For instructions for recovering the UEFI firmware, see “Recovering the server firmware (UEFI update failure)” on page 74. After you have recovered the firmware in the primary bank, do the following:

- Step 1. Restart the server.
- Step 2. When the prompt **Press F3 to restore to primary** is displayed, press F3 to start the server from the primary bank.

Nx-boot failure

Configuration changes, such as added devices or adapter firmware updates, and firmware or application code problems can cause the server to fail POST (the power-on self-test). If this occurs, the server responds in either of the following ways:

- The server restarts automatically and attempts POST again.
- The server hangs, and you must manually restart the server for the server to attempt POST again.

After a specified number of consecutive attempts (automatic or manual), the Nx-boot failure feature causes the server to revert to the default UEFI configuration and start the Setup Utility so that you can make the necessary corrections to the configuration and restart the server. If the server is unable to complete POST with the default configuration successfully, there might be a problem with the system board.

You can set the number of consecutive restart attempts that will trigger the Nx-boot failure feature, in the Setup Utility. To specify the number, click **System Settings** → **Recovery** → **POST Attempts** → **POST Attempts Limit**. Then, choose the item from the following available options: **3**, **6**, **9**, and **Disable Nx-boot failure**.

Chapter 6. Parts listing, Lenovo System x3250 M6

The following replaceable components are available for the Lenovo System x3250 M6 server, except as specified otherwise in “Replaceable server components” on page 77. For an updated parts listing, go to <http://www.lenovo.com/support>.

Replaceable server components

This topic describes the replaceable server components for Lenovo System x3250 M6.

Replaceable components consist of structural parts, and field replaceable units (FRUs):

- **Structural parts:** Purchase and replacement of structural parts (components, such as chassis assembly, cover, and bezel) is your responsibility. If Lenovo acquires or installs a structural component at your request, you will be charged for the service. For the list of structural parts, see “Structural parts” on page 83.
- **Tier 1 customer replaceable unit (CRU):** Replacement of Tier 1 CRUs is your responsibility. If Lenovo installs a Tier 1 CRU at your request, you will be charged for the installation.
- **Tier 2 customer replaceable unit:** You may install a Tier 2 CRU yourself or request Lenovo to install it, at no additional charge, under the type of warranty service that is designated for your server.

For information about the terms of the warranty and getting service and assistance, see the *Warranty Information* document that comes with the server. For more information about getting service and assistance, see Appendix D “Getting help and technical assistance” on page 661.

Visit <http://www.lenovo.com/serverproven/> for the latest options supporting plan.

The following illustration shows the major components in the server. The illustrations in this document might differ slightly from your hardware. For a list of structural parts, see “Structural parts” on page 83.

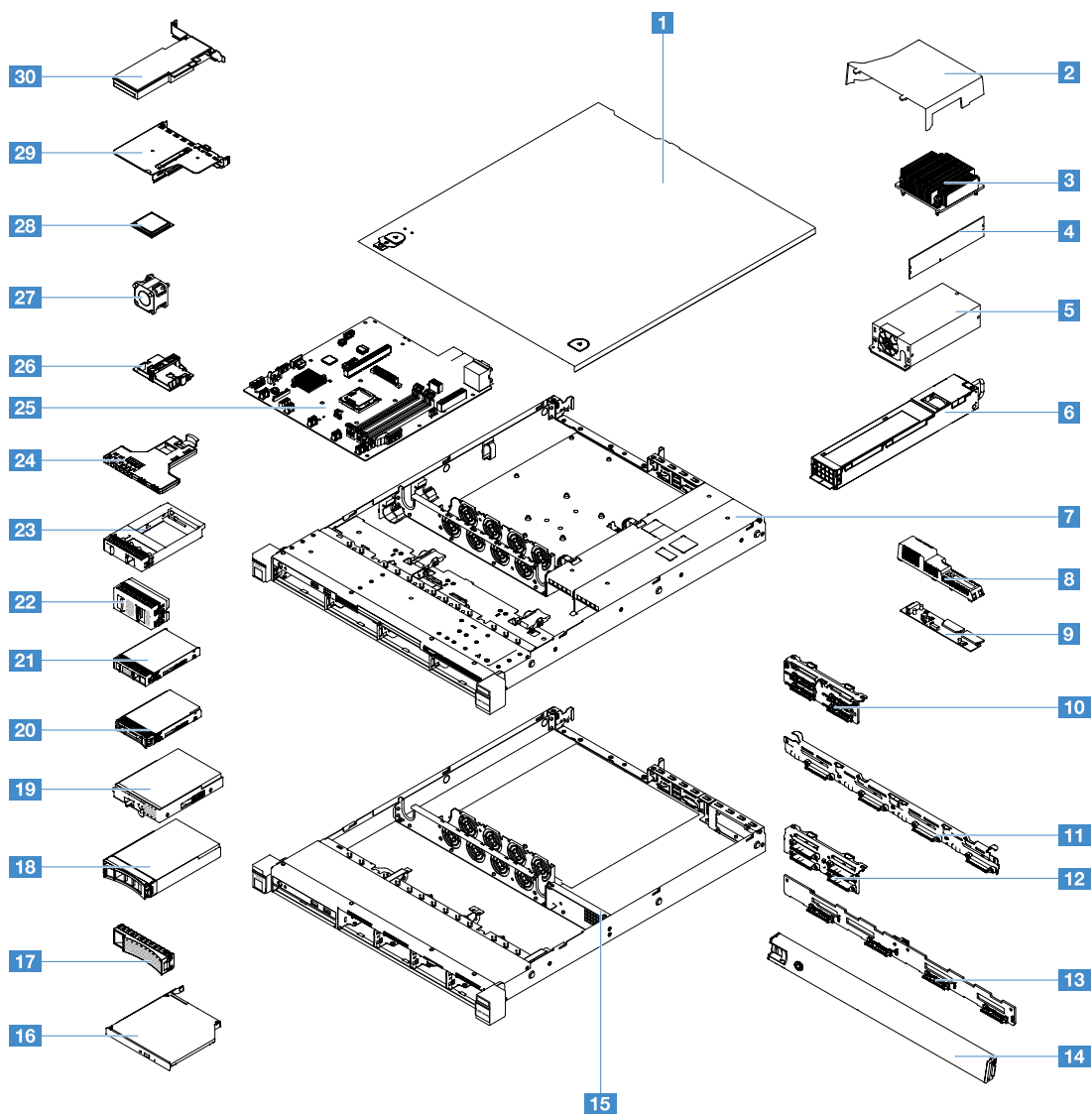

The following table lists the part numbers for the server replaceable components.

Index	Description	CRU part number (Tier 1)	CRU part number (Tier 2)
3	Heat sink		00YJ784
4	Memory, 4 GB dual-rank 1.2 V, DDR4, 2133 MHz, ECC UDIMM	46W0811	
4	Memory, 8 GB dual-rank 1.2 V, DDR4, 2133 MHz, ECC UDIMM	46W0819	
4	Memory, 16 GB dual-rank 1.2 V, DDR4, 2133 MHz, ECC UDIMM	46W0815	
5	Fixed power supply, 300 watts		00YD993
6	Hot-swap power supply, 460 watts	69Y5939	
9	Power distribution board		00YJ453
10	Backplate assembly, four 2.5-inch simple-swap hard disk drives, software RAID		00YE174
10	Backplate assembly, four 2.5-inch simple-swap hard disk drives, hardware RAID		00YE172

Index	Description	CRU part number (Tier 1)	CRU part number (Tier 2)
10	Backplate assembly, eight 2.5-inch simple-swap hard disk drives, hardware RAID		00YE173
11	Backplate assembly, four 3.5-inch simple-swap hard disk drives, software RAID		00YE171
10	Backplate assembly, four 3.5-inch simple-swap hard disk drives, hardware RAID		00YE170
12	Backplane, four 2.5-inch hot-swap hard disk drives	00FJ755	
13	Backplane, four 3.5-inch hot-swap hard disk drives	00FJ752	
16	Ultra-Slim SATA DVD-ROM, 9.5 mm	00FL352	
16	Ultra-Slim SATA Multi-Burner, 9.5 mm	00FL353	
18	Hard disk drive, 3.5-inch hot-swap, SATA, 500 GB, 7.2 K	81Y9787	
18	Hard disk drive, 3.5-inch hot-swap, SATA, 2 TB, 7.2 K	00FN114	
18	Hard disk drive, 3.5-inch hot-swap, SATA, 4 TB, 7.2 K	00FN144	
18	Hard disk drive, 3.5-inch hot-swap, SATA, 6 TB, 7.2 K	00FN174	
18	Hard disk drive, 3.5-inch hot-swap, SAS, 2 TB, 7.2 K	00FN189	
18	Hard disk drive, 3.5-inch hot-swap, SAS, 4 TB, 7.2 K	00FN209	
18	Hard disk drive, 3.5-inch hot-swap, SAS, 6 TB, 7.2 K	00FN229	
19	Hard disk drive, 3.5-inch simple-swap, SATA, 500 GB, 7.2 K	81Y9803	
19	Hard disk drive, 3.5-inch simple-swap, SATA, 2 TB, 7.2 K	00FN119	
19	Hard disk drive, 3.5-inch simple-swap, SATA, 4 TB, 7.2 K	00FN149	
20	Hard disk drive, 2.5-inch hot-swap, SATA, 1 TB, 7.2 K	00AJ142	
20	Hard disk drive, 2.5-inch hot-swap, SATA, 2 TB, 7.2 K	00NA527	
20	Hard disk drive, 2.5-inch hot-swap, SAS, 1 TB, 7.2 K	00NA492	
20	Hard disk drive, 2.5-inch hot-swap, SAS, 2 TB, 7.2 K	00NA497	
20	Hard disk drive, 2.5-inch hot-swap, SAS, 300 GB, 15 K	00WG661	
20	Hard disk drive, 2.5-inch hot-swap, SAS, 600 GB, 15 K	00WG666	
20	Hard disk drive, 2.5-inch hot-swap, SAS, 300 GB, 10 K	00WG686	
20	Hard disk drive, 2.5-inch hot-swap, SAS, 600 GB, 10 K	00WG691	
20	Hard disk drive, 2.5-inch hot-swap, SAS, 900 GB, 10 K	00WG696	
20	Hard disk drive, 2.5-inch hot-swap, SAS, 1.2 TB, 10 K	00WG701	
20	Hard disk drive, 2.5-inch hot-swap, SAS, 1.8 TB, 10 K	00NA272	
20	Solid-state drive, 2.5-inch hot-swap, SATA, 120 GB	00WG621	
20	Solid-state drive, 2.5-inch hot-swap, SATA, 240 GB	00WG626	
20	Solid-state drive, 2.5-inch hot-swap, SATA, 480 GB	00WG631	
20	Solid-state drive, 2.5-inch hot-swap, SATA, 800 GB	00WG636	
21	Hard disk drive, 2.5-inch simple-swap, SATA, 1 TB, 7.2 K	00NA627	
21	Hard disk drive, 2.5-inch simple-swap, SATA, 2 TB, 7.2 K	00NA537	
23	Hard disk drive filler, one 2.5-inch hard disk drive	00FW856	

Index	Description	CRU part number (Tier 1)	CRU part number (Tier 2)
24	Front I/O assembly	00AL324	
25	System board		00YJ451
27	System fan	00YJ785	
28	Microprocessor, Intel Pentium G4520, 3.6 GHz, 3 MB, 2133 MHz, 65 W (2-core)		00YE094
28	Microprocessor, Intel Pentium G4500, 3.5 GHz, 3 MB, 2133 MHz, 65 W (2-core)		00YE095
28	Microprocessor, Intel Pentium G4500T, 3.0 GHz, 3 MB, 2133 MHz, 35 W (2-core)		00YE096
28	Microprocessor, Intel Pentium G4400, 3.3 GHz, 3 MB, 2133 MHz, 65 W (2-core)		00YE097
28	Microprocessor, Intel Pentium G4400T, 2.9 GHz, 3 MB, 2133 MHz, 35 W (2-core)		00YE098
28	Microprocessor, Intel Core-i3 6320, 3.9 GHz, 4 MB, 2133 MHz, 65 W (2-core)		00YE089
28	Microprocessor, Intel Core-i3 6300, 3.8 GHz, 4 MB, 2133 MHz, 65 W (2-core)		00YE090
28	Microprocessor, Intel Core-i3 6300T, 3.3 GHz, 4 MB, 2133 MHz, 35 W (2-core)		00YE091
28	Microprocessor, Intel Core-i3 6100, 3.7 GHz, 3 MB, 2133 MHz, 65 W (2-core)		00YE092
28	Microprocessor, Intel Core-i3 6100T, 3.2 GHz, 3 MB, 2133 MHz, 35 W (2-core)		00YE093
28	Microprocessor, Intel Xeon E3-1280 v5, 3.7 GHz, 8 MB cache, 2133 MHz, 80 W (4-core)		00YE086
28	Microprocessor, Intel Xeon E3-1270 v5, 3.6 GHz, 8 MB cache, 2133 MHz, 80 W (4-core)		00YE082
28	Microprocessor, Intel Xeon E3-1260L v5, 2.9 GHz, 8 MB cache, 2133 MHz, 45 W (4-core)		00YE087
28	Microprocessor, Intel Xeon E3-1240L v5, 2.1 GHz, 8 MB cache, 2133 MHz, 25 W (4-core)		00YE088
28	Microprocessor, Intel Xeon E3-1240 v5, 3.5 GHz, 8 MB cache, 2133 MHz, 80 W (4-core)		00YE083
28	Microprocessor, Intel Xeon E3-1230 v5, 3.4 GHz, 8 MB cache, 2133 MHz, 80 W (4-core)		00YE084
28	Microprocessor, Intel Xeon E3-1220 v5, 3.0 GHz, 8 MB cache, 2133 MHz, 80 W (4-core)		00YE085
28	Microprocessor, Intel Celeron G3920, 2.9 GHz, 2 MB, 2133 MHz, 65 W (2-core)		00YE099
28	Microprocessor, Intel Celeron G3900, 2.8 GHz, 2 MB, 2133 MHz, 65 W (2-core)		00YE100
28	Microprocessor, Intel Celeron G3900T, 2.6 GHz, 2 MB, 2133 MHz, 35 W (2-core)		00YE101
30	ServeRAID M1210 SAS/SATA Controller	00JY196	

Index	Description	CRU part number (Tier 1)	CRU part number (Tier 2)
30	ServeRAID M1215 SAS/SATA Controller	46C9115	
30	ServeRAID M5225 SAS/SATA Controller	00AE939	
30	ServeRAID M5210 SAS/SATA Controller	46C9111	
30	ServeRAID M5200 Series 1GB Cache (RAID 5 Upgrade)	47C8657	
30	ServeRAID M5200 Series 1GB Flash (RAID 5 Upgrade)	47C8661	
30	ServeRAID M5200 Series 2GB Flash (RAID 5 Upgrade)	47C8665	
30	ServeRAID M5200 Series 4GB Flash (RAID 5 Upgrade)	47C8669	
30	N2215 SAS/SATA HBA	47C8676	
30	N2225 SAS/SATA HBA	00AE914	
30	QLogic 8 Gb FC Single-port HBA	00Y5628	
30	QLogic 8 Gb FC Dual-port HBA	00Y5629	
30	Emulex 8 Gb FC Single-port HBA	42D0491	
30	Emulex 8 Gb FC Dual-port HBA	00JY848	
30	Intel X710 2x10GbE SFP+ Adapter	81Y3522	
30	Broadcom NetXtreme I Dual Port GbE Adapter	90Y9373	
30	Intel I350-T2 2xGbE BaseT Adapter	00AG512	
30	Intel I350-T4 4xGbE BaseT Adapter	00AG522	
30	Emulex VFA5.2 2x10 GbE SFP+ PCIe Adapter	00AG573	
30	Intel X550-T2 Dual Port 10GBase-T Adapter	00MM862	
	Operating temperature enhancement kit	46W9221	
	Battery, 3.0 volts	33F8354	
	Label, chassis	00YE179	
	Serial Port Upgrade Kit	00KC965	
	PCI riser card	00YJ452	
	RDX 3.0 external tape drive	00MW718	
	Keyboard, professional, US English 103P RoHS v2	00AL883	
	Keyboard, pointing device, US English 103P RoHS v2	00MW364	
	Mouse, two button optical wheel	00MW370	
	RDX 3.0 External TD	00MW718	
	Cable, 3 meters external USB 3.0	00MW395	
	Cable, Mini-SAS, four 3.5-inch hard-disk-drive backplate, software RAID	00YJ410	
	Cable, Mini-SAS, four 2.5-inch hard-disk-drive backplate, software RAID	00YJ411	
	Cable, Mini-SAS, four 3.5-inch hard-disk-drive backplate, hardware RAID	00YJ412	
	Cable, Mini-SAS, the first four 2.5-inch hard-disk-drive backplate, hardware RAID	00YJ413	

Index	Description	CRU part number (Tier 1)	CRU part number (Tier 2)
	Cable, Mini-SAS, the second four 2.5-inch hard-disk-drive backplate, hardware RAID	00YJ414	
	Cable, Mini-SAS, four 3.5-inch or the first four 2.5-inch hard-disk-drive backplane	00YJ415	
	Cable, Mini-SAS, the second four 2.5-inch hard-disk-drive backplane	00YJ416	
	Power cable, backplane, four 2.5-inch hot-swap hard disk drive	00YJ417	
	Power cable, backplane, four 3.5-inch hot-swap hard disk drive	00YJ418	
	Power cable, system board	00YJ419	
	Power cable, microprocessor	00YJ420	
	Signal cable, power distribution board to system board	00YJ421	
	Cable, SATA Slimline	81Y6774	
	Cable, Mini-SAS 1 m, 6 Gbps, SFF-8644 to SFF-8088	00YE304	
	Cable, Mini-SAS 2 m, 6 Gbps, SFF-8644 to SFF-8088	00YE305	
	Cable, Mini-SAS 4 m, 6 Gbps, SFF-8644 to SFF-8088	00YE306	
	Cable, Mini-SAS 6 m, 6 Gbps, SFF-8644 to SFF-8088	00YE307	
	ServeRAID M5100 Series flash power module	00JY023	
	Cable, configuration (eight HDDs)		
	Cable, power (for four hot-swap HDDs)		
	Cable, SATA slimline		
	Cable, SAS signal (840 mm)		

Consumable parts (parts that are purchased separately) are not covered by the Lenovo Statement of Limited Warranty. The following consumable parts are available for purchase from the retail store.

Index	Description	Part number
1	Server cover, for server models with hot swap power supply	00YE167
1	Server cover, for server models with fixed power supply	00YE168
2	Air baffle	00AL326
7	Chassis assembly, 3.5-inch HDD (hot-swap power supply model)	00YE164
15	Chassis assembly, 2.5-inch HDD (fixed power supply model)	00YE165
	Chassis assembly, 2.5-inch HDD (hot-swap power supply model)	00YE166
	Chassis assembly, 3.5-inch HDD (fixed power supply model)	00YE163
8	Power distribution board cover	00YE169
17	Hard disk drive filler, 3.5-inch hot-swap	69Y5364
17	Hard disk drive filler, 3.5-inch simple-swap	69Y5368
26	RAID adapter battery or flash power module holder	00Y8545
	Optical drive filler	00YE175
	Rack release latch (Left)	00YE176
	Rack release latch (Right)	00YE177

Index	Description	Part number
	PCI riser-card cage	00YE192
	Label, system service, FRU/CRU	00YE353
	Rail kit	00MV390
	Power-supply filler	49Y4821

Structural parts

Structural parts are not covered by the Lenovo Statement of Limited Warranty. You can place an order on the structural parts from the Lenovo retail store.

The following structural parts are available for purchase from the retail store.

Table 24. Structural parts, Type 3633 and 3943

Index	Description	Part number
14	Security bezel	00KF695
22	2.5-inch hard disk drive filler (for two hard disk drives)	00KF683

To order a structural part, do the following:

Note: Changes are made periodically to the Lenovo Web site. The actual procedure might vary slightly from what is described in this document.

1. Go to <http://www.ibm.com>.
2. From the **Products** menu, select **Upgrades, accessories & parts**.
3. Click **Obtain maintenance parts**; then, follow the instructions to order the part from the retail store.

If you need help with your order, call the toll-free number that is listed on the retail parts page, or contact your local Lenovo representative for assistance.

Power cords

For your safety, a power cord with a grounded attachment plug is provided to use with this product. To avoid electrical shock, always use the power cord and plug with a properly grounded outlet.

Lenovo power cords used in the United States and Canada are listed by Underwriter's Laboratories (UL) and certified by the Canadian Standards Association (CSA).

For units intended to be operated at 115 volts: Use a UL-listed and CSA-certified cord set consisting of a minimum 18 AWG, Type SVT or SJT, three-conductor cord, a maximum of 15 feet in length and a parallel blade, grounding-type attachment plug rated 15 amperes, 125 volts.

For units intended to be operated at 230 volts (U.S. use): Use a UL-listed and CSA-certified cord set consisting of a minimum 18 AWG, Type SVT or SJT, three-conductor cord, a maximum of 15 feet in length and a tandem blade, grounding-type attachment plug rated 15 amperes, 250 volts.

For units intended to be operated at 230 volts (outside the U.S.): Use a cord set with a grounding-type attachment plug. The cord set should have the appropriate safety approvals for the country in which the equipment will be installed.

Power cords for a specific country or region are usually available only in that country or region.

Power cord part number	Used in these countries and regions
39M5206	China
39M5102	Australia, Fiji, Kiribati, Nauru, New Zealand, Papua New Guinea
39M5123	Afghanistan, Albania, Algeria, Andorra, Angola, Armenia, Austria, Azerbaijan, Belarus, Belgium, Benin, Bosnia and Herzegovina, Bulgaria, Burkina Faso, Burundi, Cambodia, Cameroon, Cape Verde, Central African Republic, Chad, Comoros, Congo (Democratic Republic of), Congo (Republic of), Cote D'Ivoire (Ivory Coast), Croatia (Republic of), Czech Republic, Dahomey, Djibouti, Egypt, Equatorial Guinea, Eritrea, Estonia, Ethiopia, Finland, France, French Guyana, French Polynesia, Germany, Greece, Guadeloupe, Guinea, Guinea Bissau, Hungary, Iceland, Indonesia, Iran, Kazakhstan, Kyrgyzstan, Laos (People's Democratic Republic of), Latvia, Lebanon, Lithuania, Luxembourg, Macedonia (former Yugoslav Republic of), Madagascar, Mali, Martinique, Mauritania, Mauritius, Mayotte, Moldova (Republic of), Monaco, Mongolia, Morocco, Mozambique, Netherlands, New Caledonia, Niger, Norway, Poland, Portugal, Reunion, Romania, Russian Federation, Rwanda, Sao Tome and Principe, Saudi Arabia, Senegal, Serbia, Slovakia, Slovenia (Republic of), Somalia, Spain, Suriname, Sweden, Syrian Arab Republic, Tajikistan, Tahiti, Togo, Tunisia, Turkey, Turkmenistan, Ukraine, Upper Volta, Uzbekistan, Vanuatu, Vietnam, Wallis and Futuna, Yugoslavia (Federal Republic of), Zaire
39M5130 39M5179	Denmark
39M5144	Bangladesh, Lesotho, Macao, Maldives, Namibia, Nepal, Pakistan, Samoa, South Africa, Sri Lanka, Swaziland, Uganda
39M5151	Abu Dhabi, Bahrain, Botswana, Brunei Darussalam, Channel Islands, China (Hong Kong S.A.R.), Cyprus, Dominica, Gambia, Ghana, Grenada, Iraq, Ireland, Jordan, Kenya, Kuwait, Liberia, Malawi, Malaysia, Malta, Myanmar (Burma), Nigeria, Oman, Polynesia, Qatar, Saint Kitts and Nevis, Saint Lucia, Saint Vincent and the Grenadines, Seychelles, Sierra Leone, Singapore, Sudan, Tanzania (United Republic of), Trinidad and Tobago, United Arab Emirates (Dubai), United Kingdom, Yemen, Zambia, Zimbabwe
39M5158	Liechtenstein, Switzerland
39M5165	Chile, Italy, Libyan Arab Jamahiriya
39M5172	Israel
39M5095	220 - 240 V Antigua and Barbuda, Aruba, Bahamas, Barbados, Belize, Bermuda, Bolivia, Caicos Islands, Canada, Cayman Islands, Colombia, Costa Rica, Cuba, Dominican Republic, Ecuador, El Salvador, Guam, Guatemala, Haiti, Honduras, Jamaica, Mexico, Micronesia (Federal States of), Netherlands Antilles, Nicaragua, Panama, Peru, Philippines, Saudi Arabia, Thailand, Taiwan, United States of America, Venezuela
39M5076 39M5081	110 - 120 V Antigua and Barbuda, Aruba, Bahamas, Barbados, Belize, Bermuda, Bolivia, Caicos Islands, Canada, Cayman Islands, Colombia, Costa Rica, Cuba, Dominican Republic, Ecuador, El Salvador, Guam, Guatemala, Haiti, Honduras, Jamaica, Mexico, Micronesia (Federal States of), Netherlands Antilles, Nicaragua, Panama, Peru, Philippines, Saudi Arabia, Thailand, Taiwan, United States of America, Venezuela
39M5463	Taiwan
39M5087	Thailand
39M5219	Korea (Democratic People's Republic of), Korea (Republic of)
39M5199	Japan
39M5068	Argentina, Paraguay, Uruguay

Power cord part number	Used in these countries and regions
39M5226	India
39M5240 39M5241	Brazil
39M5375 39M5377 39M5378 39M5509 39M5512	Canada, United States of America

Chapter 7. Removing and installing server components

This chapter provides instructions on how to remove and install hardware for your server. You can expand the capabilities of your server by adding new hardware devices, such as memory modules, PCIe cards, or other server options, and maintain your server by replacing the failing hardware devices. If you are handling a server option, refer to the appropriate installation and or removal instructions in this topic along with the instructions that come with the option.

For information about warranty terms, see the *Warranty Information* document that comes with the server. For more information about getting service and assistance, see Appendix D “Getting help and technical assistance” on page 661.

Before removing or installing server components

Attention: Static electricity that is released to internal server components when the server is powered-on might cause the system to halt, which might result in the loss of data. To avoid this potential problem, always use an electrostatic-discharge wrist strap or other grounding system when removing or installing a device.

System reliability guidelines

To help ensure proper system cooling and system reliability, make sure that the following requirements are met:

- Each of the drive bays has a drive in it, otherwise a filler and electromagnetic compatibility (EMC) shield installed must be installed.
- If the server has redundant power, each of the power-supply bays has a power supply installed.
- There is adequate space around the server to ensure the server cooling system works properly. Leave approximately 50 mm (2.0 inches) of open space around the front and rear of the server. Do not place objects in front of the fans. For proper cooling and airflow, install the server cover before you turn on the server. Operating the server for extended periods of time (more than 30 minutes) with the server cover removed might damage server components.
- You have followed the cabling instructions that come with optional adapters.
- You have replaced a failed fan as soon as possible.
- You have replaced a hot-swap drive within two minutes of removal.
- You operate the server with the air baffle installed. Operating the server without the air baffle might cause the microprocessor to overheat.

Working inside the server with the power on

Guidelines to work inside the server with the power on.

Attention: Static electricity that is released to internal server components when the server is powered-on might cause the server to halt, which might result in the loss of data. To avoid this potential problem, always use an electrostatic-discharge wrist strap or other grounding system when you work inside the server with the power on.

You might have to have the server turned on while the cover is off, to look at system-board LEDs or replace hot-swap components. Follow these guidelines when you work inside a server that is turned on:

- Avoid wearing loose-fitting clothing on your forearms. Button long-sleeved shirts before working inside the server; do not wear cuff links while you are working inside the server.

- Do not allow your necktie or scarf to hang inside the server.
- Remove jewelry, such as bracelets, necklaces, rings, and loose-fitting wrist watches.
- Remove items from your shirt pocket, such as pens and pencils, that could fall into the server as you lean over it.
- Avoid dropping any metallic objects, such as paper clips, hairpins, and screws, into the server.

Handling static-sensitive devices

Attention: Static electricity can damage the server and other electronic devices. To avoid damage, keep static-sensitive devices in their static-protective packages until you are ready to install them.

To reduce the possibility of damage from electrostatic discharge, observe the following precautions:

- Limit your movement. Movement can cause static electricity to build up around you.
- The use of a grounding system is recommended. For example, wear an electrostatic-discharge wrist strap, if one is available. Always use an electrostatic-discharge wrist strap or other grounding system when working inside the server with the power on.
- Handle the device carefully, holding it by its edges or its frame.
- Do not touch solder joints, pins, or exposed circuitry.
- Do not leave the device where others can handle and damage it.
- While the device is still in its static-protective package, touch it to an unpainted metal surface on the outside of the server for at least two seconds. This drains static electricity from the package and from your body.
- Remove the device from its package and install it directly into the server without setting down the device. If it is necessary to set down the device, put it back into its static-protective package. Do not place the device on the server cover or on a metal surface.
- Take additional care when handling devices during cold weather. Heating reduces indoor humidity and increases static electricity.

Removing and installing server components

This section provides information for removing and installing server components.

Removing and installing structural parts

Installation of structural parts is your responsibility. If Lenovo installs a structural part at your request, you will be charged.

The illustrations in this document might differ slightly from your hardware.

Removing the server cover

To remove the server cover, do the following:

- Step 1. Turn off the server. Then, disconnect all external cables and remove all peripheral devices.
- Step 2. If the server has been installed in a rack, remove the server from the rack. See the *Rack Installation Instructions* that comes with the server.
- Step 3. Put the server on a working area before you remove any server components from the server.

- Step 4. Put your thumbs on the blue cover-release buttons **1** and **2**. Firmly press the button **1** and slide the server cover toward the rear of the server until the cover is disengaged from the chassis.

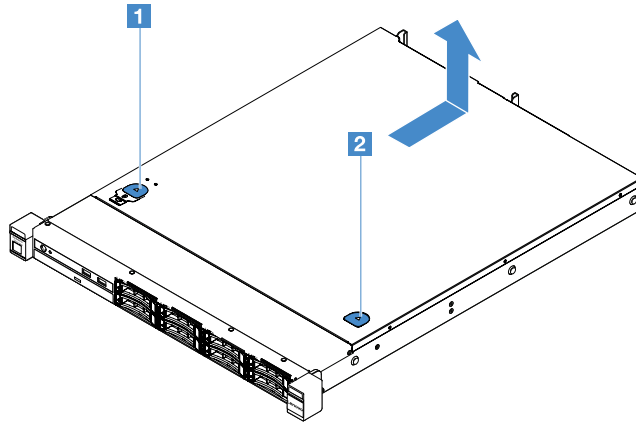

Figure 14. Server cover removal

- Step 5. Lift the server cover off the server and set it aside.

Attention: For proper cooling and airflow, install the server cover before you turn on the server.

Installing the server cover

To install the server cover, do the following:

Note: Ensure that all components have been reassembled properly and that no tools or loose screws are left inside your server.

- Step 1. Position the server cover on top of the server.
Step 2. Slide the server cover toward the front of the server. Make sure that the server cover properly engages all the inset tabs on the server.

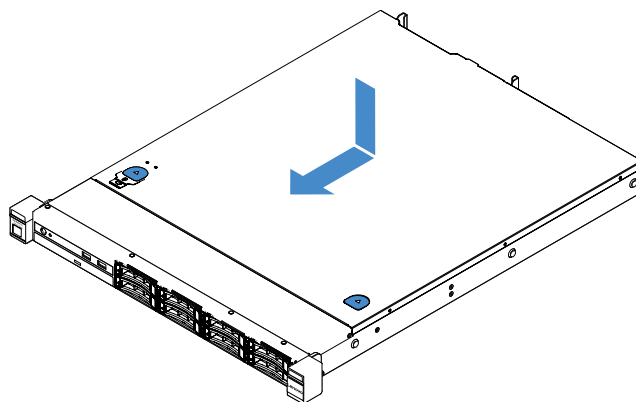

Figure 15. Server cover installation

- Step 3. Install the server into the rack. See the *Rack Installation Instructions* that comes with the server.
Step 4. Reconnect all the external cables. Then, turn on the server and peripheral devices.

Removing the air baffle

To remove the air baffle, do the following:

- Step 1. Turn off the server. Then, disconnect all external cables and remove all peripheral devices.
- Step 2. Remove the server cover. See “Removing the server cover” on page 88.
- Step 3. Hold the air baffle and lift it out of the server.

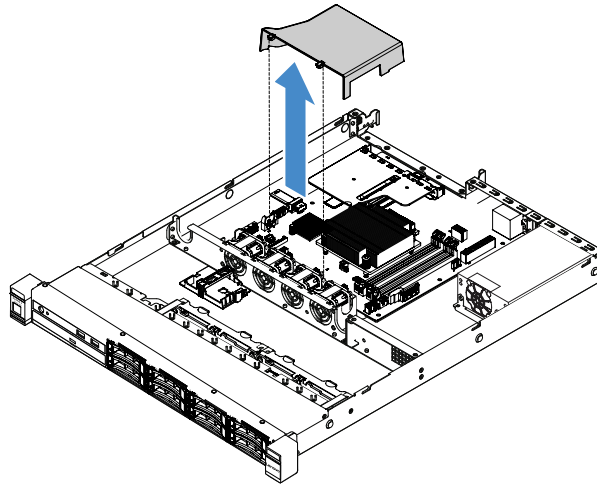

Figure 16. Air baffle removal

Attention: For proper cooling and airflow, install the air baffle before you turn on the server. Operating the server with the air baffle removed might damage server components.

Installing the air baffle

If you have removed the air baffle, you need to reinstall the air baffle or install a new one if the old one is broken.

To install the air baffle, do the following:

Step 1. Align the air baffle tabs **1** with the notches in the server fan cage. Then, lower the air baffle into the server and press the air baffle down until it is securely seated.

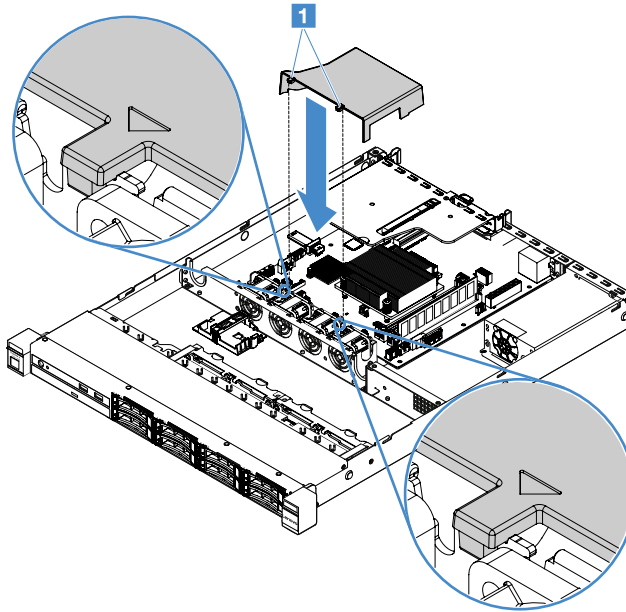

Figure 17. Air baffle installation

Step 2. Complete the parts replacement. See “Completing the parts replacement” on page 172.

Removing the security bezel

To remove the security bezel, do the following:

Step 1. Turn off the server.

Step 2. Use the key to unlock the security bezel to the open position.

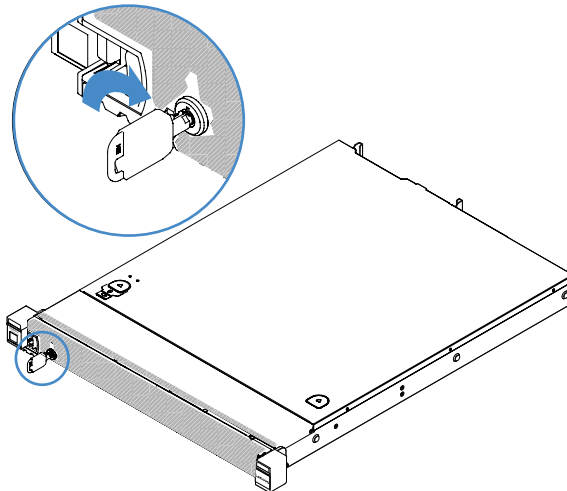

Figure 18. Unlocking the security bezel

Step 3. Press the release latch **1** and pivot the security bezel outward to remove it from the chassis.

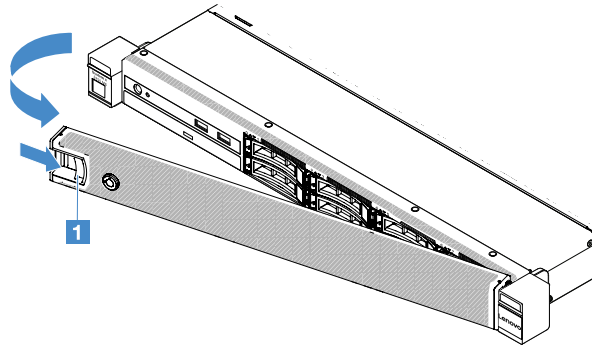

Figure 19. Security bezel removal

Installing the security bezel

To install the security bezel, do the following:

Step 1. Turn off the server.

Step 2. Carefully insert the tab on the security bezel into the slot on the right side of the chassis. Then, press and hold the release latch and pivot the security bezel inward until the other side clicks into place.

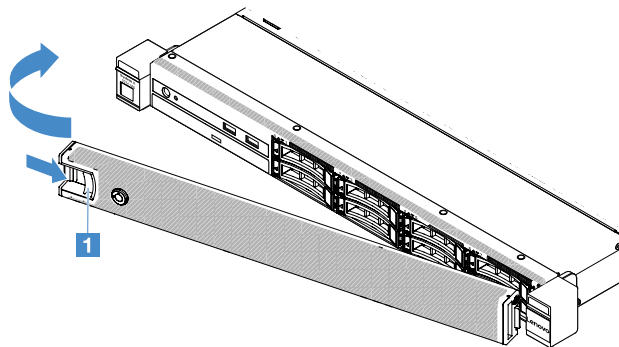

Figure 20. Security bezel installation

Step 3. Use the key to lock the security bezel to the closed position.

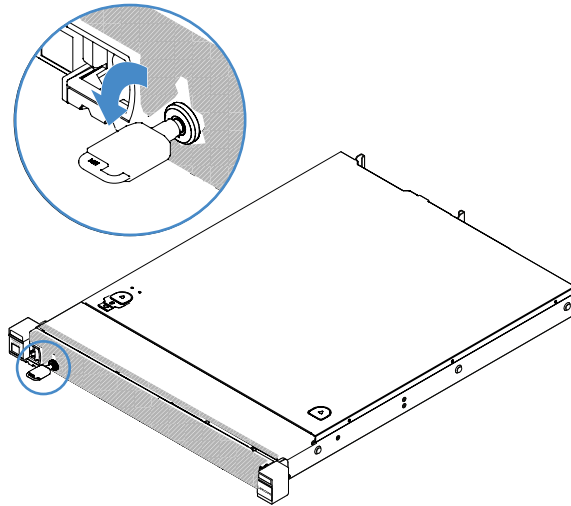

Figure 21. Locking the security bezel

Removing the PCI riser-card assembly

To remove the PCI riser-card assembly, do the following:

- Step 1. Turn off the server. Then, disconnect all external cables and remove all peripheral devices.
- Step 2. Remove the server cover. See “Removing the server cover” on page 88.
- Step 3. Grasp the blue tabs on the PCI riser-card assembly and lift the PCI riser-card assembly to release it from the chassis.

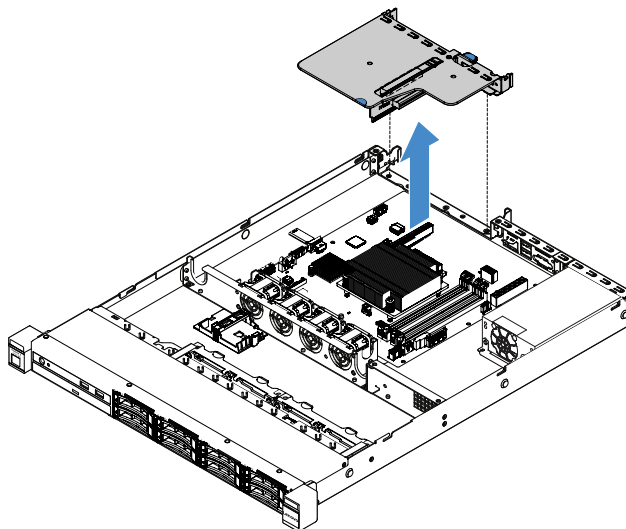

Figure 22. PCI riser-card assembly removal

- Step 4. Disconnect any cables from the adapters on the PCI riser-card assembly.
- Step 5. Remove the adapter from the PCI riser-card assembly. See “Removing an adapter” on page 110.
- Step 6. Place the PCI riser-card assembly on a flat, static-protective surface.

Step 7. Install the PCI riser-card assembly. See “Installing the PCI riser-card assembly” on page 94.

Installing the PCI riser-card assembly

If you have removed the PCI riser-card assembly, you need to install it the before turning on the server. To install the PCI riser-card assembly, do the following:

- Step 1. Install the appropriate adapters onto the PCI riser-card assembly. See “Installing an adapter” on page 111.
- Step 2. Reconnect any adapter cables that you disconnected when you removed the PCI riser-card assembly.
- Step 3. Carefully align the PCI riser-card assembly with the guides on the rear of the server and with the PCI riser-card connector on the system board. Then, place your fingers on the blue tabs and press down on the PCI riser-card assembly. Make sure that the riser-card assembly is fully seated in the connector on the system board.

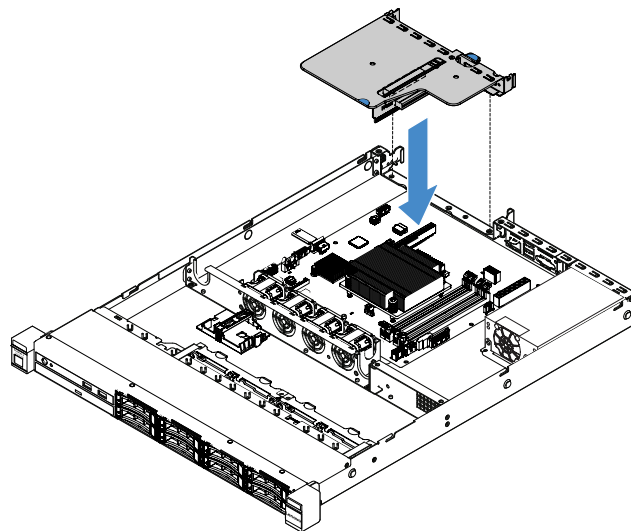

Figure 23. PCI riser-card assembly installation

Step 4. Complete the parts replacement. See “Completing the parts replacement” on page 172.

Removing the flash power module holder

Note: The flash power module holder is supported on the 2.5-inch-drive server models only.

To remove the flash power module holder, do the following:

- Step 1. Turn off the server. Then, disconnect all external cables and remove all peripheral devices.
- Step 2. Remove the server cover. See “Removing the server cover” on page 88.
- Step 3. Remove the flash power module. See “Removing a RAID adapter battery or flash power module” on page 114.

Step 4. Remove the two screws that secure the holder and then remove the holder.

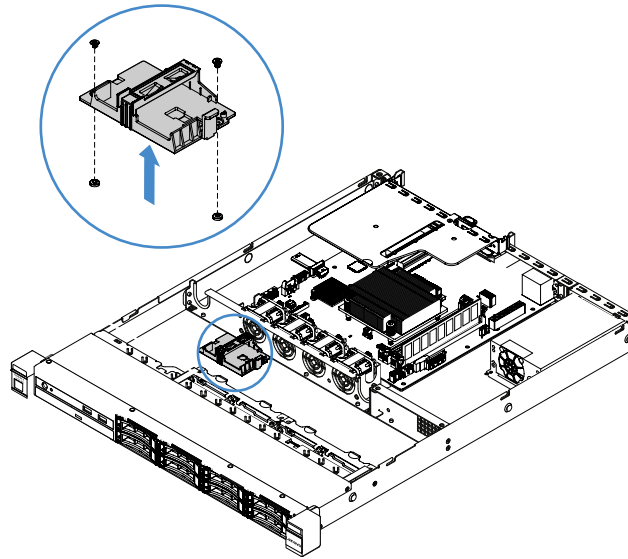

Figure 24. Flash power module holder removal

Step 5. Complete the parts replacement. See “Completing the parts replacement” on page 172.

Installing flash power module holder

Note: The RAID adapter battery or flash power module holder is supported on the 2.5-inch-drive server models only.

To install flash power module holder, do the following:

Step 1. Turn off the server. Then, disconnect all external cables and remove all peripheral devices.

Step 2. Remove the server cover. See “Removing the server cover” on page 88.

- Step 3. Place the holder on the chassis as shown and align the screw holes in the holder with the ones in the chassis. Then, install the two screws and make sure that the holder is secured firmly on the chassis.

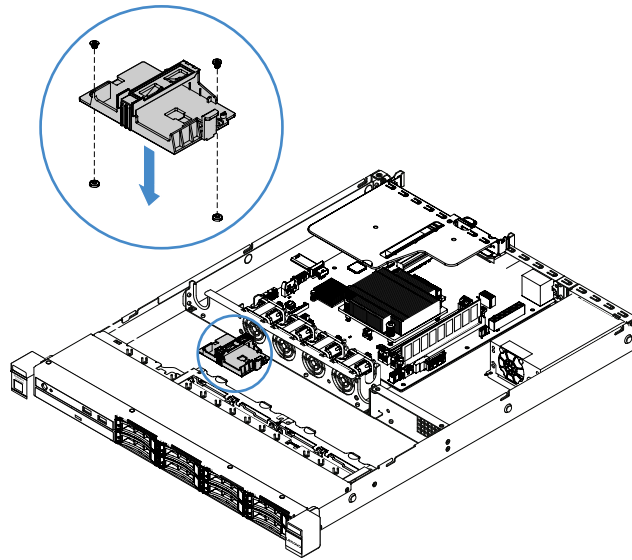

Figure 25. Flash power module holder installation

- Step 4. Install a flash power module. See “Installing a RAID adapter battery or flash power module” on page 115.
- Step 5. Complete the parts replacement. See “Completing the parts replacement” on page 172.

Removing and installing Tier 1 CRUs

Installation of Tier 1 CRUs is your responsibility. If Lenovo installs a Tier 1 CRU at your request, you will be charged.

The illustrations in this document might differ slightly from your hardware.

Removing a DIMM

To remove a DIMM, do the following:

- Step 1. Turn off the server. Then, disconnect all external cables and remove all peripheral devices.
- Step 2. Remove the server cover. See “Removing the server cover” on page 88.
- Step 3. Remove the air baffle. See “Removing the air baffle” on page 90.

Step 4. Carefully open the retaining clips **1** on each end of the DIMM slot and remove the DIMM.

Attention: To avoid breaking the retaining clips or damaging the DIMM slots, handle the clips gently.

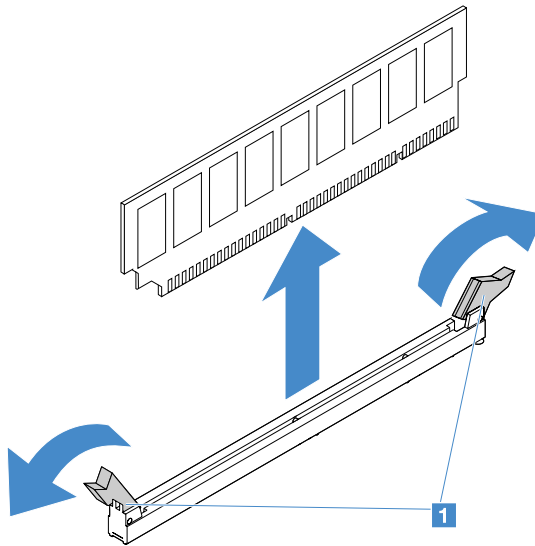

Figure 26. DIMM removal

Step 5. Install a new DIMM if you have installed only one DIMM. See “Installing a DIMM” on page 99.

DIMM installation guidelines

The following tips describe the types of DIMMs that the server supports and other information that you must consider when you install DIMMs.

- Confirm that the server supports the DIMM that you are installing. Go to: <http://www.lenovo.com/serverproven/>
- When you install or remove DIMMs, the server configuration information changes. When you restart the server, the system displays a message indicating that the memory configuration has been changed. You can use the Setup Utility program to view the server configuration information. See “Using the Setup Utility program” on page 28.
- The server supports only industry-standard DDR4, 2133 MHz, PC4-17000 (single-rank or dual-rank), unbuffered DIMMs with error correcting code (ECC).
- The server supports a maximum of four single-rank or dual-rank unbuffered DIMMs.
- The maximum operating speed of the server is determined by the slowest DIMM in the server.
- If you install a pair of DIMMs in DIMM slots 3 and 1, the size and speed of the DIMMs that you install in DIMM slots 1 and 3 must match each other. However, they do not have to be the same size and speed as the DIMMs that are installed in DIMM slots 4 and 2.
- You can use compatible DIMMs from various manufacturers in the same pair.
- To determine the type of a DIMM, see the label on the DIMM. The information on the label is in the format x GB nRxx PC4-xxxxxx-xx-xx-xx. The “nRxx” indicates whether the DIMM is single-rank (n=1) or dual-rank (n=2).
- The amount of usable memory is reduced, depending on the system configuration. A certain amount of memory must be reserved for system resources. To view the total amount of installed memory

and the amount of configured memory, run Setup Utility. For additional information, see “Configuring the server” on page 26.

- The specifications of a DDR4 DIMM are on a label on the DIMM, in the following format:
gggGBpheRxff PC4-wwwwaa-mccd-bb

where:

- *gggGB* is the total capacity of the DIMM (for example, 1 GB, 2 GB, or 4 GB)
- *pheR* is the number of package ranks and number of logical ranks per package rank
p has the following variables:
 - 1 = 1 package rank of SDRAMs installed
 - 2 = 2 package ranks of SDRAMs installed
 - 3 = 3 package ranks of SDRAMs installed
 - 4 = 4 package ranks of SDRAMs installed
- *he*: blank for monolithic DRAMs and others for modules using stacked DRAM.
h is the DRAM package type. It has the following variables:
 - D = multi-load DRAM stacking (DDP)
 - Q = multi-load DRAM stacking (QDP)
 - D = single load DRAM stacking (3DS)
- e*: blank for SDP, DDP and QDP and others for modules using 3DS stacks, logical ranks per package rank
It has the following variables:
 - 2 = 2 logical ranks in each package rank
 - 4 = 4 logical ranks in each package rank
 - 8 = 8 logical ranks in each package rank
- *xff* is the device organization or bit width of SDRAMs (for example, x4, x8, or x16)
 - x4 = x4 organization (four DQ lines per SDRAM)
 - x8 = x8 organization
 - x16 = x16 organization
- *wwww* is the DIMM speed, in MBps (for example, 2133, 2400, 2666, 2933, or 3200)
aa is the SDRAM speed grade
- *m* is the DIMM type
 - E = Unbuffered DIMM (UDIMM) (x64-bit primary data bus) with ECC (x8-bit module data bus)
 - L = Load Reduced DIMM (LRDIMM) (x64-bit primary data bus) with ECC (x8-bit module data bus)
 - R = Registered DIMM (RDIMM) (x64-bit primary data bus) with ECC (x8-bit module data bus)
 - U = Unbuffered DIMM with no ECC (x64-bit primary data bus)
- cc* is the reference design file for the design of the DIMM
d is the revision number of the used reference design
- *bb* is the JEDEC SPD Revision Encoding and Additions level

To locate the DIMM slots on the system board, see “System-board connectors” on page 21.

The following sections provide additional information specific to unbuffered DIMMs that you must consider.

Unbuffered DIMMs (UDIMMs)

The following tips provide information that you must consider when you install UDIMMs.

- The memory channels run at the lowest common frequency of the DIMMs installed.
- The UDIMM options that are available for the server are 4 GB, 8 GB, and 16 GB DIMMs.
- The server supports up to two single-rank or dual-rank UDIMMs per channel.
- The following table lists the supported UDIMM population.

Table 25. Supported UDIMM population per channel

DIMM slots per channel	DIMMs installed in each channel	DIMM type	DIMM speed	Ranks per DIMM (any combination)
2	1	Unbuffered DDR4 ECC	2133	Dual-rank
2	2	Unbuffered DDR4 ECC	2133	Dual-rank

- The following table lists the maximum DIMM population using ranked UDIMMs.

Table 26. Maximum memory population using ranked UDIMMs (depending on your model)

Number of UDIMMs	DIMM type	Size	Total memory
4	Dual-rank UDIMMs	16 GB	64 GB

- The following table shows the UDIMM memory installation sequence to optimize the system performance.

Table 27. DIMM installation sequence

Number of DIMMs	Installation sequence (DIMM slots)
First pair of DIMMs	3, 1
Second pair of DIMMs	4, 2

Installing a DIMM

To install a DIMM, do the following:

- Step 1. Turn off the server. Then, disconnect all external cables and remove all peripheral devices.
- Step 2. Remove the server cover. See “Removing the server cover” on page 88.
- Step 3. Remove the air baffle. See “Removing the air baffle” on page 90.
- Step 4. Locate the DIMM slots on the system board. Then, refer to “Unbuffered DIMMs (UDIMMs)” on page 99 and ensure that you observe the installation rules and sequence.
- Step 5. Touch the static-protective package that contains the DIMM to any unpainted metal surface on the outside of the server. Then, remove the DIMM from the package.

Step 6. Open the retaining clips **1** on each end of the DIMM slot. Then, install the DIMM into the slot.

Attention: To avoid breaking the retaining clips or damaging the DIMM slots, open and close the clips gently.

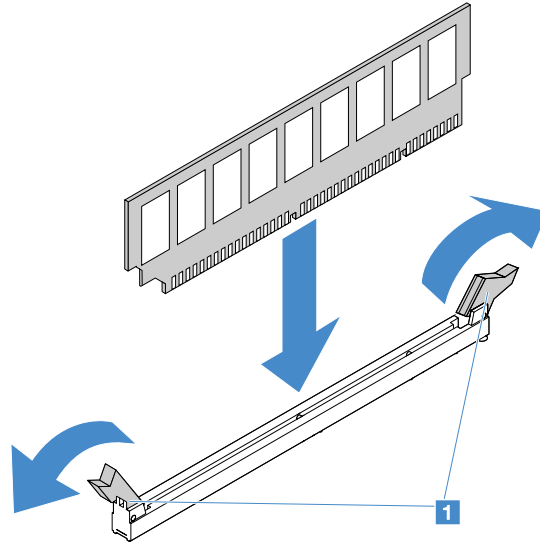

Figure 27. DIMM installation

Step 7. Firmly press the DIMM straight down into the connector by applying pressure on both ends of the DIMM simultaneously. The retaining clips snap into the locked position when the DIMM is firmly seated in the connector.

Note: If there is a gap between the DIMM and the retaining clips, the DIMM has not been correctly inserted; open the retaining clips, remove the DIMM, and then reinsert it.

Step 8. Complete the parts replacement. See “Completing the parts replacement” on page 172.

Removing a hot-swap hard disk drive

The drive ID that is assigned to each drive is printed on the front of the server. The ID numbers and the drive bay numbers are the same. For detailed information, see “Front view” on page 15.

Attention:

- To avoid damage to the hard disk drive connectors, make sure that the server cover is in place and fully closed whenever you install or remove a hard disk drive.
- To ensure adequate system cooling, do not operate the server for more than two minutes without either a hard disk drive or a filler installed in each bay.
- Before you change hard disk drives, HDD controllers (including controllers that are integrated on the system board), HDD backplanes, or HDD cables, back up all important data that is stored on the hard disk drives.
- Before you remove any component of a RAID array, back up all RAID configuration information and data on your drive.

To remove a hot-swap hard disk drive, do the following:

- Step 1. Remove the security bezel. See “Removing the security bezel” on page 91.
- Step 2. Press the release button **1** to open the handle **2** of the drive. Then, grasp the handle and pull the hot-swap hard disk drive out of the drive bay.

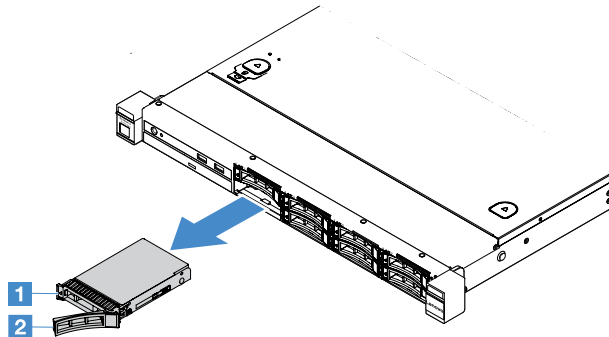

Figure 28. 2.5-inch hot-swap hard disk drive removal

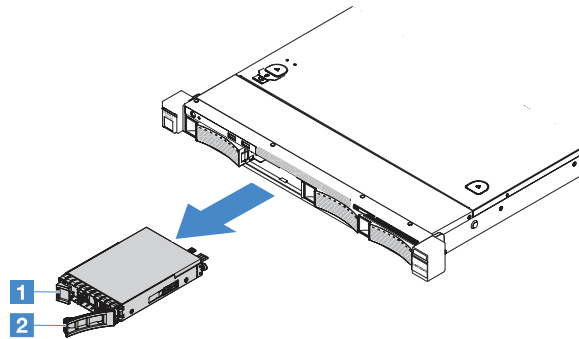

Figure 29. 3.5-inch hot-swap hard disk drive removal

- Step 3. Install a new hot-swap hard disk drive or install a filler into the bay.
- Step 4. Reinstall the security bezel. See “Installing the security bezel” on page 92.

Installing a hot-swap hard disk drive

The drive ID that is assigned to each drive is printed on the front of the server. The ID numbers and the drive bay numbers are the same. For detailed information, see “Front view” on page 15.

Attention: To avoid damage to the hard disk drive connectors, make sure that the server cover is in place and fully closed whenever you install or remove a hard disk drive.

The following tips describe the type of hard disk drives that the server supports and other information that you must consider when you install a hard disk drive.

- Locate the documentation that comes with the hard disk drive and follow those instructions in addition to the instructions in this topic.
- Make sure that you have all the cables and other equipment specified in the documentation that comes with the drive.
- Select the bay in which you want to install the drive.

- Check the instructions that come with the drive to determine whether you have to set any switches or jumpers on the drive. If you are installing a SAS or SATA hard disk drive, be sure to set the SAS or SATA ID for that device.
- You can install up to eight 2.5-inch or four 3.5-inch hot-swap SAS or SATA hard disk drives in the server.
- The electromagnetic interference (EMI) integrity and cooling of the server are protected by having all bays and PCI and PCI Express slots covered or occupied. When you install a drive, save the EMC shield and filler from the bay in case you later remove the device.
- For a complete list of supported optional devices for the server, go to:
<http://www.lenovo.com/serverproven/>

To install a hot-swap hard disk drive, do the following:

Step 1. Remove the security bezel. See “Removing the security bezel” on page 91.

Step 2. Touch the static-protective package that contains the drive to any unpainted metal surface on the server. Then, remove the drive from the package and place it on a static-protective surface.

- Step 3. Install the hard disk drive into the drive bay:
- Remove the hard-disk-drive filler **1**. Keep the filler in a safe place. Make sure that the tray handle **2** is in the open (unlocked) position.
 - Gently push the drive into the bay until the drive stops.
 - Close the tray handle to the locked position.

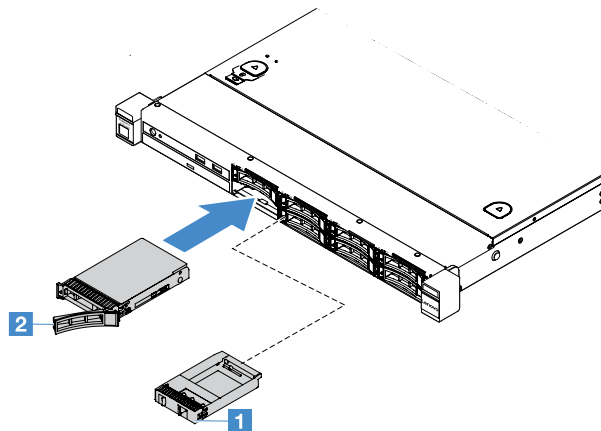

Figure 30. 2.5-inch hot-swap hard disk drive installation

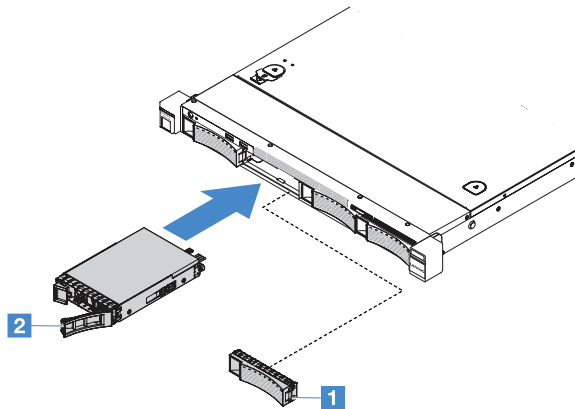

Figure 31. 3.5-inch hot-swap hard disk drive installation

- Step 4. Check the hard disk drive status LED to verify that the hard disk drive is operating properly. If the yellow hard disk drive status LED of a drive is lit continuously, that drive is faulty and must be reinstalled. If the green hard disk drive activity LED is flashing, the drive is being accessed.

Note: If the server is configured for RAID operation using a ServeRAID adapter, you might have to reconfigure your disk arrays after you install hard disk drives. For additional information about RAID operation and complete instructions for using the ServeRAID adapter, see the ServeRAID adapter documentation.

- Step 5. Reinstall the security bezel. See “Installing the security bezel” on page 92.

Removing a simple-swap hard disk drive

The drive ID that is assigned to each drive is printed on the front of the server. The ID numbers and the drive bay numbers are the same. For detailed information, see “Front view” on page 15.

Attention:

- To avoid damage to the hard disk drive connectors, make sure that the server cover is in place and fully closed whenever you install or remove a hard disk drive.
- To ensure adequate system cooling, do not operate the server for more than two minutes without either a hard disk drive or a filler installed in each bay.

To remove a simple-swap hard disk drive, do the following:

Step 1. Turn off the server. Then, disconnect all external cables and remove all peripheral devices.

Step 2. Remove the security bezel. See “Removing the security bezel” on page 91.

Step 3. Remove a simple-swap hard disk drive.

- For the 2.5-inch drive, slide the release latch **1** to the left and pull the hard disk drive out of the drive bay at the same time.

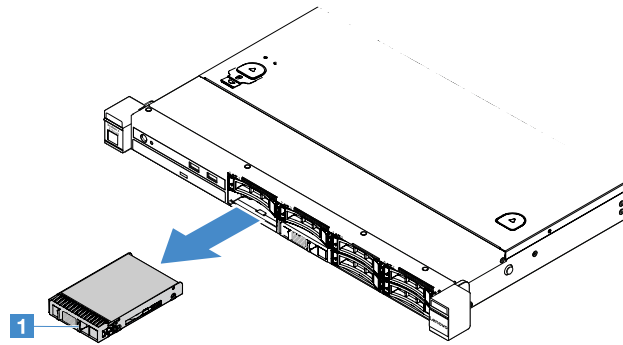

Figure 32. 2.5-inch simple-swap hard disk drive removal

- For the 3.5-inch drive, remove the drive bay filler **1** from the server. Then, slide the release latch **2** to the right and pull the hard disk drive out of the drive bay at the same time.

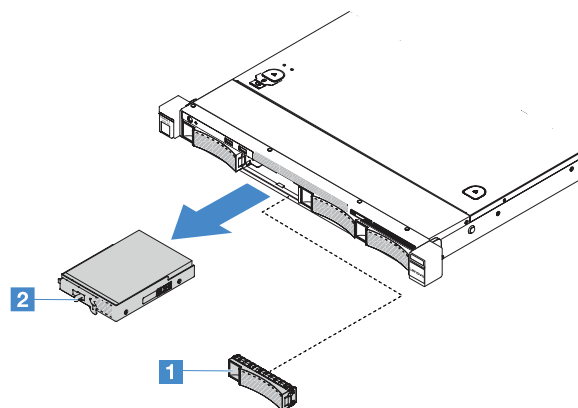

Figure 33. 3.5-inch simple-swap hard disk drive removal

Step 4. Depending on your needs, install a new drive and then reinstall the filler or install the filler directly.

Step 5. Complete the parts replacement. See “Completing the parts replacement” on page 172.

Step 6. Reinstall the security bezel. See “Installing the security bezel” on page 92.

Installing a simple-swap hard disk drive

The drive ID that is assigned to each drive is printed on the front of the server. The ID numbers and the drive bay numbers are the same. For detailed information, refer to “Front view” on page 15.

Before you install a simple-swap SAS or SATA hard disk drive, read the following information. For a list of supported hard disk drives, go to <http://www.lenovo.com/serverproven/>.

- Locate the documentation that comes with the hard disk drive and follow those instructions in addition to the instructions in this topic.
- Make sure that you have all the cables and other equipment specified in the documentation that comes with the drive.
- Select the bay in which you want to install the drive.
- Check the instructions that come with the drive to determine whether you have to set any switches or jumpers on the drive. If you are installing a SAS or SATA device, be sure to set the SAS or SATA ID for that device.
- You can install up to eight 2.5-inch or four 3.5-inch simple-swap SAS or SATA hard disk drives in the server.
- The electromagnetic interference (EMI) integrity and cooling of the server are protected by having all bays and PCI and PCI Express slots covered or occupied. When you install a drive, save the EMC shield and filler from the bay in case you later remove the device.
- For a complete list of supported optional devices for the server, go to: <http://www.lenovo.com/serverproven/>

To install a simple-swap hard disk drive, do the following:

- Step 1. Turn off the server. Then, disconnect all external cables and remove all peripheral devices.
- Step 2. Remove the security bezel. See “Removing the security bezel” on page 91.
- Step 3. Remove the filler from the empty drive bay.
- Step 4. Touch the static-protective package that contains the drive to any unpainted metal surface on the server. Then, remove the drive from the package and place it on a static-protective surface.

Step 5. Install the hard disk drive into the drive bay.

- For the 2.5-inch drive, slide the release latch **1** to the left. Then, gently push the drive into the bay until the drive stops.

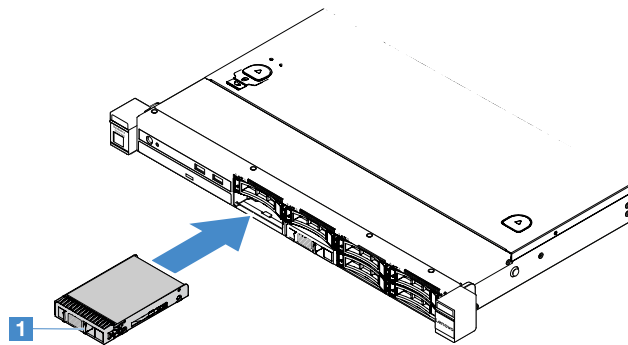

Figure 34. 2.5-inch simple-swap hard disk drive installation

- For the 3.5-inch drive, slide the release latch **2** to the right and gently push the drive into the bay until the drive stops. Then, install a new drive and then reinstall the filler or install the filler directly.

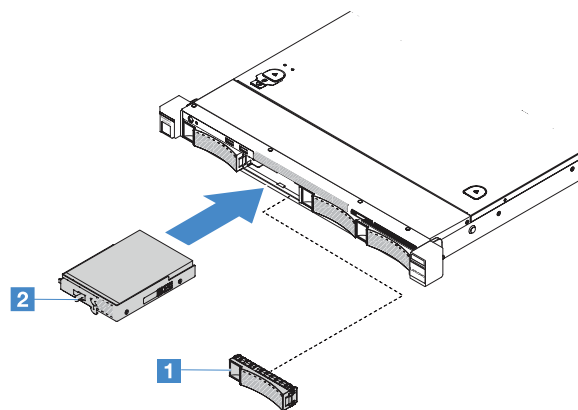

Figure 35. 3.5-inch simple-swap hard disk drive installation

Step 6. Complete the parts replacement. See “Completing the parts replacement” on page 172.

Step 7. Reinstall the security bezel. See “Installing the security bezel” on page 92.

Removing the optical drive

To remove the optical drive, do the following:

Step 1. Turn off the server. Then, disconnect all external cables and remove all peripheral devices.

Step 2. Remove the security bezel. See “Removing the security bezel” on page 91.

Step 3. Remove the server cover. See “Removing the server cover” on page 88.

Step 4. Press the release tab **1** as shown, hold the optical drive, and push the drive from the rear at the same time to slide it out of the bay.

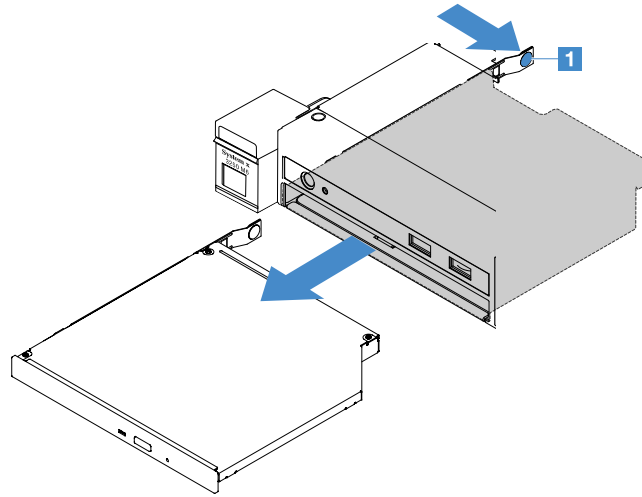

Figure 36. Optical drive removal

- Step 5. Disconnect the optical drive cable.
- Disconnect the optical drive cable from the system board.
 - Press the connector latch (on the left of the cable connector) as shown, grasp the cable connector, and slide it to the right. Then, remove the optical drive cable from the connector bracket on the chassis.

Attention: Do not disconnect the optical drive cable by using excessive force.

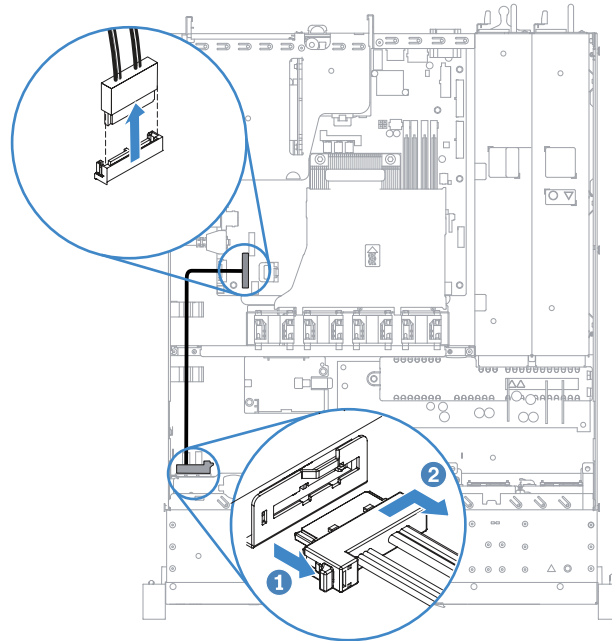

Figure 37. Optical drive cable disconnection

- Step 6. Attach the drive retention clip that you removed from the optical drive to the side of the optical drive filler. See “Installing the optical drive” on page 109. Then, slide the optical drive filler into the optical drive bay until the optical drive filler clicks into place.

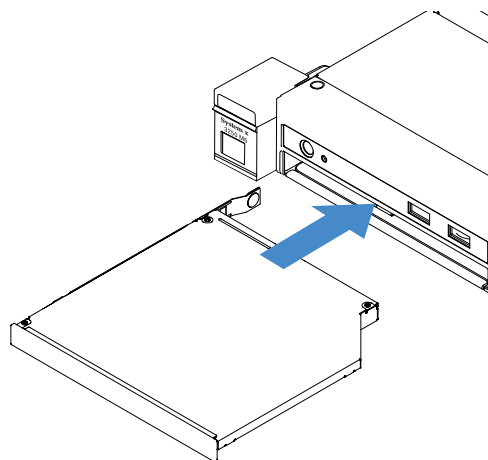

Figure 38. Optical drive filler installation

Step 7. Complete the parts replacement. See “Completing the parts replacement” on page 172.

Step 8. Reinstall the security bezel. See “Installing the security bezel” on page 92.

Installing the optical drive

The following tips describe the type of optical drives that the server supports and other information that you must consider when you install an optical drive. For a list of supported optical drives, go to:

<http://www.lenovo.com/serverproven/>

- Locate the documentation that comes with the optical drive and follow those instructions in addition to the instructions in this topic.
- Make sure that you have all the cables and other equipment specified in the documentation that comes with the optical drive.
- The server supports one ultra-slim SATA optical drive.

To install the optical drive, do the following:

Step 1. Turn off the server. Then, disconnect all external cables and remove all peripheral devices.

Step 2. Remove the security bezel. See “Removing the security bezel” on page 91.

Step 3. Remove the server cover. See “Removing the server cover” on page 88.

Step 4. Remove the optical drive filler.

Step 5. Connect the optical drive cable. Make sure that the cable is not pinched and does not cover any connectors or obstruct any components on the system board.

- a. Align the cable connector with the connector bracket on the chassis, insert the cable connector into the bracket, and slide it to the left until it is firmly seated.
- b. Connect the other end of the cable to the system board.

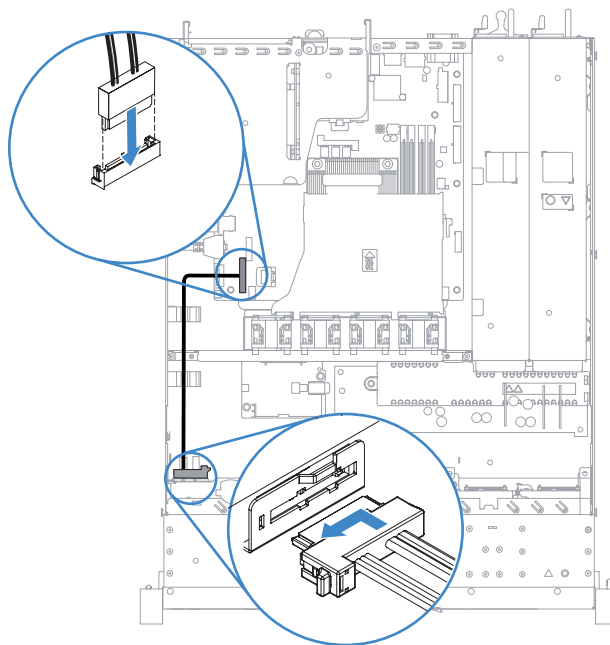

Figure 39. Optical drive cable connection

- Step 6. Touch the static-protective package that contains the new optical drive to any unpainted metal surface on the server. Then, remove the optical drive from the package and place it on a static-protective surface.
- Step 7. Follow the instructions that come with the optical drive to set any jumpers or switches.
- Step 8. Attach the drive retention clip that you removed from the optical drive filler to the side of the new optical drive. Ensure that the alignment pins **1** on the retention clip are aligned with the corresponding holes in the optical drive.

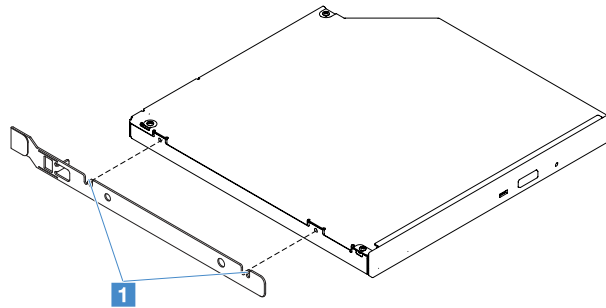

Figure 40. Optical drive retention clip installation

- Step 9. Align the optical drive with the drive bay. Then, slide the optical drive into the bay until the optical drive clicks into place.

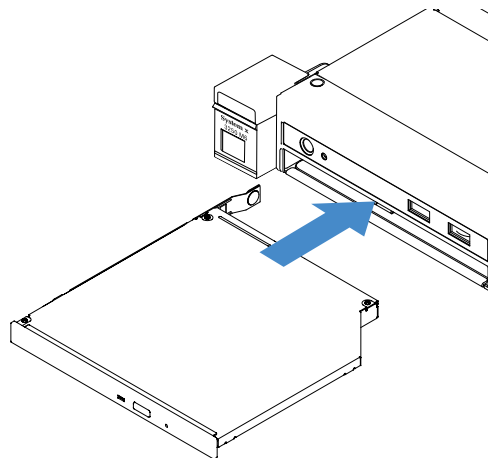

Figure 41. Optical drive installation

- Step 10. Complete the parts replacement. See “Completing the parts replacement” on page 172.
- Step 11. Reinstall the security bezel. See “Installing the security bezel” on page 92.

Removing an adapter

To remove an adapter, do the following:

- Step 1. Turn off the server. Then, disconnect all external cables and remove all peripheral devices.
- Step 2. Remove the server cover. See “Removing the server cover” on page 88.
- Step 3. Remove the PCI riser-card assembly. See “Removing the PCI riser-card assembly” on page 93.

Step 4. Disconnect cables from the adapter.

Step 5. Carefully grasp the adapter by its top edge and remove the adapter from the PCI riser-card assembly.

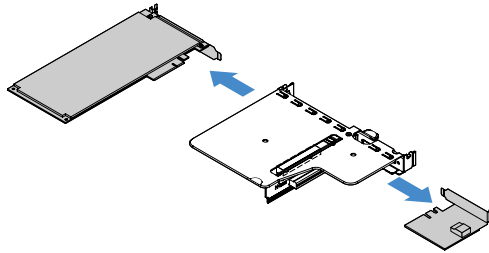

Figure 42. Adapter removal

Step 6. Complete the parts replacement. See “Completing the parts replacement” on page 172.

Installing an adapter

The following tips describe the types of adapters that the server supports and other information that you must consider when you install an adapter:

- To confirm that the server supports the adapter that you are installing, go to:
<http://www.lenovo.com/serverproven/>
- Locate the documentation that comes with the adapter and follow those instructions in addition to the instructions in this topic.
- To ensure that any of your adapters function properly on UEFI-based servers, make sure that the adapter firmware and supporting device drivers are updated to the latest version.
- The adapter slots are on the PCI riser-card assembly. You must first remove the PCI riser-card assembly to access the adapter slots 1 and 2.
 - **1** Dedicated to ServeRAID M1210 SAS/SATA Controller
 - **2** Support one PCI Express Gen3 x8 half-length, full-height adapter

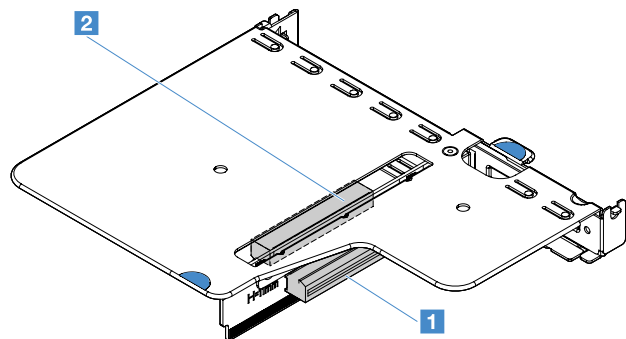

Figure 43. PCI riser-card assembly

Notes:

- If your adapter was previously configured, backup or record its configuration information, if possible, before replacing the adapter. See the documentation for your adapter for information and instructions.

- If you are replacing a ServeRAID adapter, import your RAID configuration to the replacement adapter as a foreign configuration after you finish the replacement. For more information, see *ServeRAID-M Software User Guide* at <https://support.lenovo.com/us/en/documents/migr-5086126>.

To install an adapter, do the following:

- Step 1. Turn off the server. Then, disconnect all external cables and remove all peripheral devices.
- Step 2. Remove the server cover. See “Removing the server cover” on page 88.
- Step 3. Remove the PCI riser-card assembly. See “Removing the PCI riser-card assembly” on page 93.
- Step 4. Touch the static-protective package that contains the adapter to any unpainted metal surface on the server; then, remove the adapter from the package.
- Step 5. Place the adapter, component side up, on a flat, static-protective surface and set any jumpers or switches as described by the adapter manufacturer, if necessary.
- Step 6. Connect the cables to the adapter.
- Step 7. Position the adapter near the slot on the PCI riser-card assembly. Then, press the adapter firmly into the PCI riser-card assembly. Ensure that the adapter is securely installed in the PCI riser-card assembly.

Important: Make sure that the U-shaped opening in the metal adapter bracket engages the tab **2** on the PCI riser-card cage **1**.

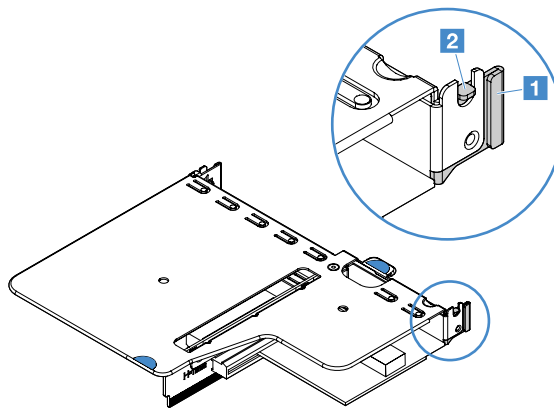

Figure 44. Adapter installation

- Step 8. Route the adapter cables. Refer to “Internal cable routing” on page 158.
- Step 9. Reinstall the PCI riser-card assembly. See “Installing the PCI riser-card assembly” on page 94.

Attention: When you install an adapter, make sure that the adapter is correctly seated in the PCI riser-card assembly and that the PCI riser-card assembly is securely seated in the riser-card connector on the system board before you turn on the server. An incorrectly seated adapter might damage the system board, the PCI riser-card assembly, or the adapter.

- Step 10. Complete the parts replacement. See “Completing the parts replacement” on page 172.

Notes:

- If the server is configured for RAID operation through an optional ServeRAID adapter, you might have to reconfigure your disk arrays after you install an adapter. For additional information about RAID operation and complete instructions for using ServeRAID Manager, see the ServeRAID documentation on the *Lenovo ServeRAID Support CD*.

- When you restart the server, you are prompted to import the existing RAID configuration to the new ServeRAID SAS/SATA controller.

Removing a ServeRAID SAS/SATA controller memory module

Note: For brevity, in this documentation the Lenovo ServeRAID SAS/SATA controller is often referred to as the SAS/SATA adapter or the ServeRAID adapter.

To remove a ServeRAID adapter memory module, do the following:

- Step 1. Turn off the server. Then, disconnect all external cables and remove all peripheral devices.
- Step 2. Remove the server cover. See “Removing the server cover” on page 88.
- Step 3. Remove the PCI riser-card assembly. See “Removing the PCI riser-card assembly” on page 93.
- Step 4. Remove the ServeRAID adapter. See “Removing an adapter” on page 110.
- Step 5. Grasp the memory module and lift to remove it from the ServeRAID adapter.

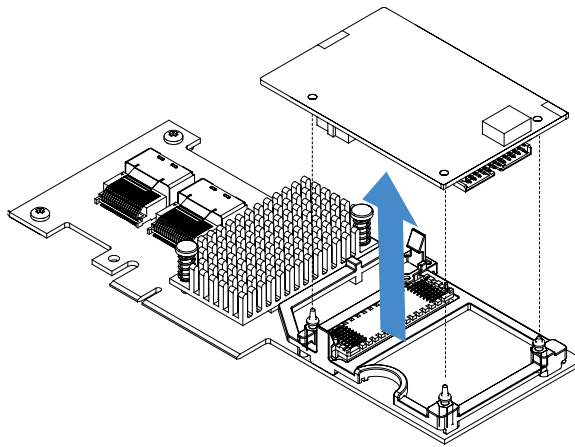

Figure 45. ServeRAID adapter memory module removal

- Step 6. Complete the parts replacement. See “Completing the parts replacement” on page 172.

Installing a ServeRAID SAS/SATA controller memory module

Note: For brevity, in this documentation the Lenovo ServeRAID SAS/SATA controller is often referred to as the SAS/SATA adapter or the ServeRAID adapter.

To install a ServeRAID adapter memory module, do the following:

- Step 1. Turn off the server. Then, disconnect all external cables and remove all peripheral devices.
- Step 2. Remove the server cover. See “Removing the server cover” on page 88.
- Step 3. Remove the PCI riser-card assembly. See “Removing the PCI riser-card assembly” on page 93.
- Step 4. Remove the ServeRAID adapter. See “Removing an adapter” on page 110.
- Step 5. Touch the static-protective package that contains the memory module to any unpainted metal surface on the server; then, remove the memory module from the package.

Step 6. Align the board-to-board connector **1** on the bottom of the memory module with the connector **2** on the ServeRAID adapter. Ensure that the three mounting studs on the ServeRAID adapter are aligned with the corresponding holes in the memory module. Carefully press the memory module onto the ServeRAID adapter until the two connectors (**1** and **2**) are firmly joined.

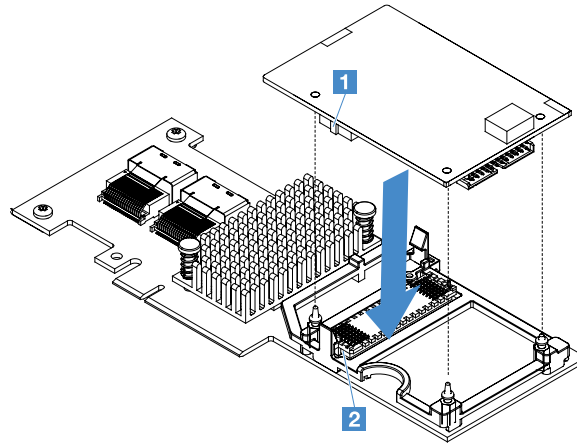

Figure 46. ServeRAID adapter memory module installation

Step 7. Reinstall the ServeRAID adapter. See “Installing an adapter” on page 111.

Step 8. Complete the parts replacement. See “Completing the parts replacement” on page 172.

Removing a RAID adapter battery or flash power module

Note: The RAID adapter battery or flash power module is supported on the 2.5-inch-drive server models only.

To remove a RAID adapter battery or flash power module, do the following:

Step 1. Turn off the server. Then, disconnect all external cables and remove all peripheral devices.

Step 2. Remove the server cover. See “Removing the server cover” on page 88.

- Step 3. Remove the RAID adapter battery or flash power module.
- Remove the retainer.
 - Open the retention clip.
 - Pull the release tab outward.
 - Lift the battery or flash power module up to remove the battery or flash power module from the holder.

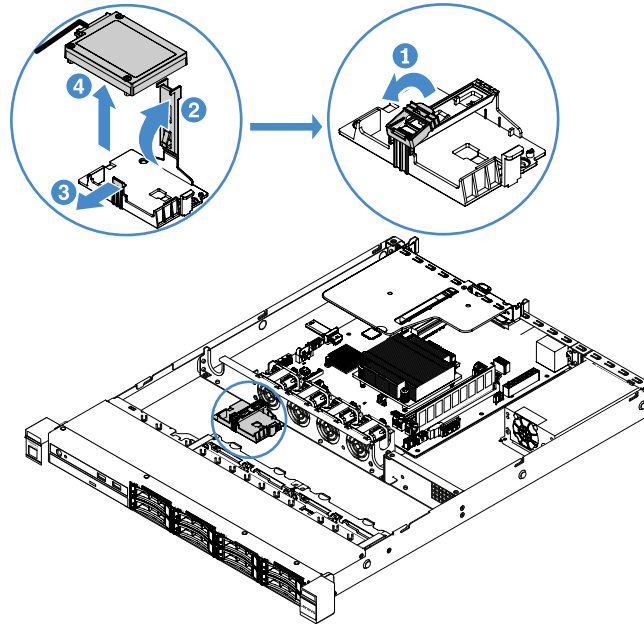

Figure 47. RAID adapter battery or flash power module removal

- Step 4. Disconnect the cable from the battery or flash power module.
- Step 5. Complete the parts replacement. See “Completing the parts replacement” on page 172.

Installing a RAID adapter battery or flash power module

When you install any RAID adapter that comes with batteries or flash power modules, sometimes it is necessary to install the batteries or flash power modules in another location in the server to prevent the batteries or flash power modules from overheating. Depending on your server model, a battery must be installed remotely near the optical drive cage or the backplane.

Note: The RAID adapter battery or flash power module is supported on the 2.5-inch-drive server models only.

To install a RAID adapter battery or flash power module in the server, do the following:

- Turn off the server. Then, disconnect all external cables and remove all peripheral devices.
- Remove the server cover. See “Removing the server cover” on page 88.
- Remove the PCI riser-card assembly. See “Removing the PCI riser-card assembly” on page 93.
- Install a RAID adapter in the PCI riser-card assembly. See “Installing an adapter” on page 111.

- Step 5. Connect one end of the cable to the connector on the RAID adapter. Make sure the relevant cables pass through the cable clips and no cables cover or obstruct the battery holder.

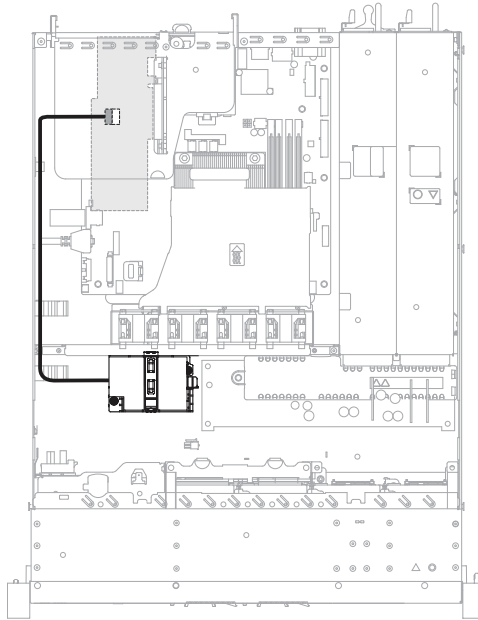

Figure 48. RAID adapter battery or flash power module cable connection

Attention: Make sure that the cable is not pinched and does not cover any connectors or obstruct any components on the system board.

- Step 6. Connect the other end of the cable to the battery or flash power module. Then, remove the retainer and open the retention clip of the battery or module holder.

- Step 7. Install the battery or flash power module.
- Pull the release tab outward.
 - Place the battery or flash power module into the holder and ensure that the holder engages the battery or flash power module securely.
 - Lower and press down on the retention clip until it snaps in place to hold the battery or flash power module firmly in place.
 - Install the retainer.

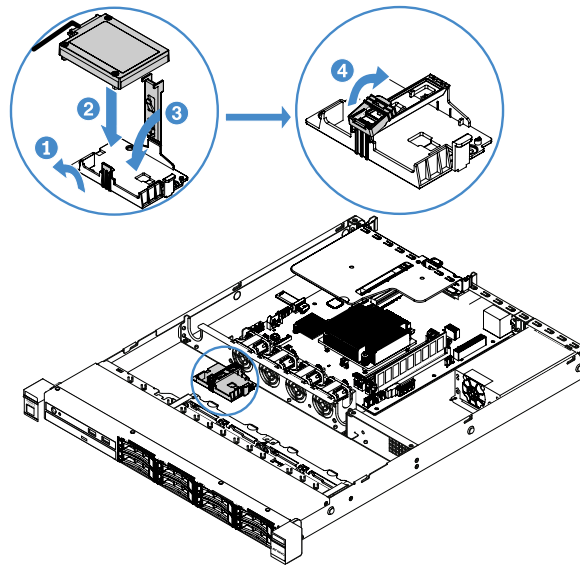

Figure 49. RAID adapter battery or flash power module installation

Note: The positioning of the remote battery or flash power module depends on the type of the remote batteries or flash power modules that you install.

- Step 8. Complete the parts replacement. See “Completing the parts replacement” on page 172.

Removing a USB embedded hypervisor flash device

To remove a USB embedded hypervisor flash device, do the following:

- Turn off the server. Then, disconnect all external cables and remove all peripheral devices.
- Remove the server cover. See “Removing the server cover” on page 88.
- Remove the air baffle. See “Removing the air baffle” on page 90.
- Remove the PCI riser-card assembly. See “Removing the PCI riser-card assembly” on page 93.
- Locate the USB embedded hypervisor flash device connector on the system board. See “System-board connectors” on page 21.

Step 6. Slide the lock bar on the flash device connector to the unlocked position and pull the USB flash device out of the connector.

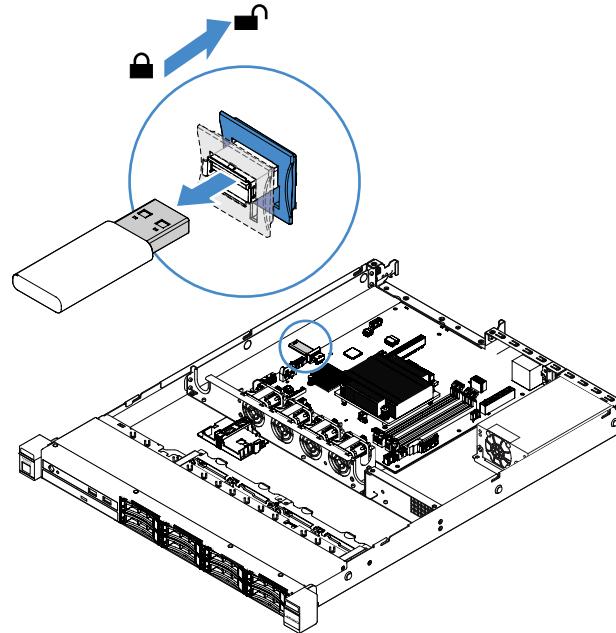

Figure 50. USB embedded hypervisor flash device removal

Step 7. Complete the parts replacement. See “Completing the parts replacement” on page 172.

Installing a USB embedded hypervisor flash device

To install a USB embedded hypervisor flash device, do the following:

- Step 1. Turn off the server. Then, disconnect all external cables and remove all peripheral devices.
- Step 2. Remove the server cover. See “Removing the server cover” on page 88.
- Step 3. Remove the air baffle. See “Removing the air baffle” on page 90.
- Step 4. Remove the PCI riser-card assembly. See “Removing the PCI riser-card assembly” on page 93.
- Step 5. Locate the USB embedded hypervisor flash device connector on the system board. See “System-board connectors” on page 21.

Step 6. Align the USB flash device with the connector on the system board and push it into the connector until it is firmly seated. Then, slide the lock bar on the flash device connector to the locked position.

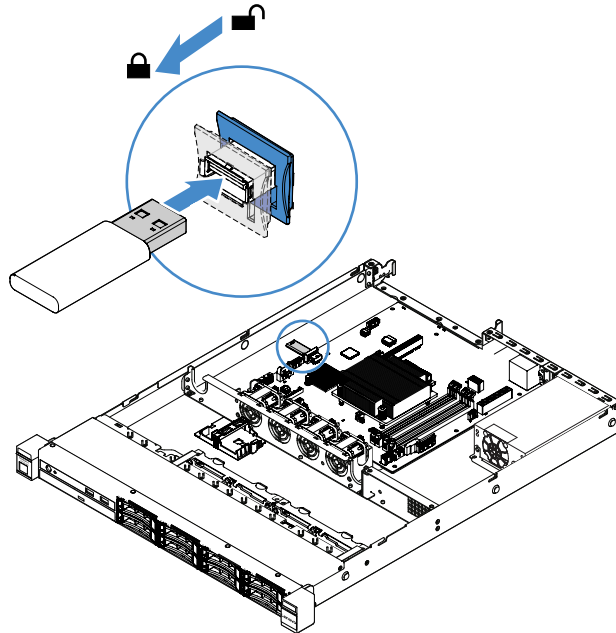

Figure 51. USB embedded hypervisor flash device installation

Step 7. Complete the parts replacement. See “Completing the parts replacement” on page 172.

Removing the front I/O assembly

The front I/O assembly contains an operator information panel and two cables.

To remove the front I/O assembly, do the following:

- Step 1. Turn off the server. Then, disconnect all external cables and remove all peripheral devices.
- Step 2. Remove the server cover. See “Removing the server cover” on page 88.

Step 3. Disconnect the USB cable and the operator information panel cable from the system board.

- To release the USB cable connector, press the release latch **1** on the top of the USB cable connector. Then, pull out and disengage the USB cable connector from the USB connector on the system board.
- To release the operator information panel cable connector, press the release latches **2** on both sides of the cable connector. Then, pull out and disengage the cable connector from the operator information panel connector on the system board.

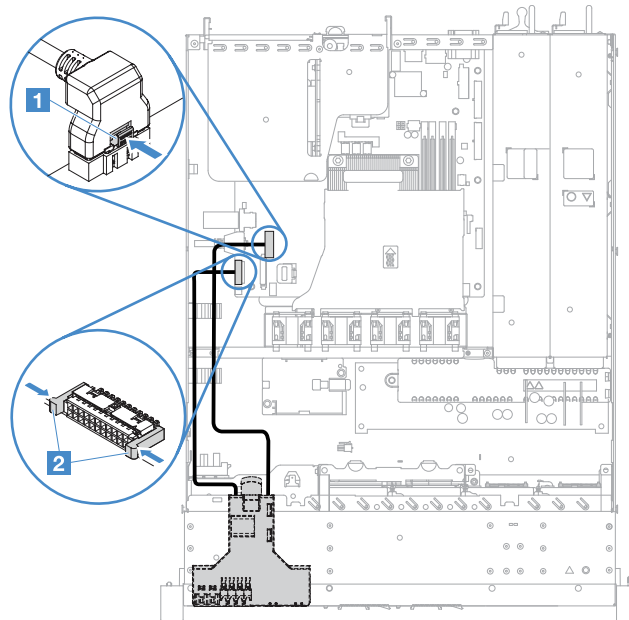

Figure 52. USB cable and operator information panel cable disconnection

Step 4. Locate the release tab on the rear of the front I/O assembly. Then, lift the release tab and carefully pull out the front I/O assembly.

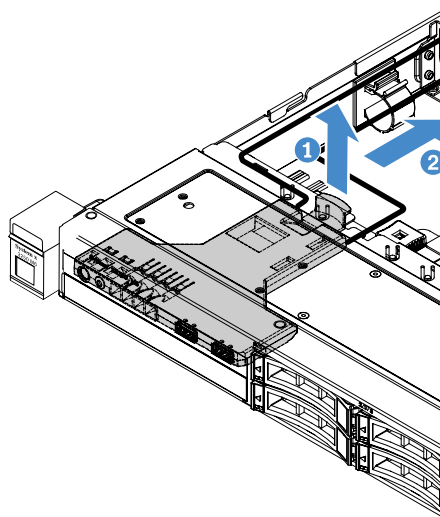

Figure 53. Front I/O assembly removal

Step 5. Install a new front I/O assembly. See “Installing the front I/O assembly” on page 121.

Installing the front I/O assembly

The front I/O assembly contains an operator information panel and two cables. If you have removed the front I/O assembly, install a new one before turning on the server.

To install the front I/O assembly, do the following:

Step 1. Carefully push the front I/O assembly into the server as shown until the front I/O assembly clicks into place.

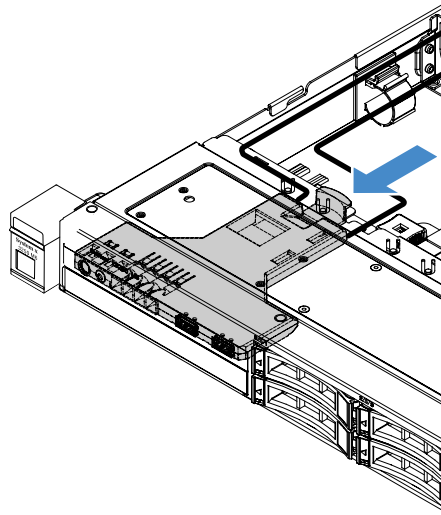

Figure 54. Front I/O assembly installation

Step 2. Reconnect the USB cable and the operator information panel cable to the connectors on the system board. Make sure the relevant cables pass through the cable clips.

Step 3. Complete the parts replacement. See “Completing the parts replacement” on page 172.

Removing the operating temperature enhancement kit

To remove the operating temperature enhancement kit, do the following:

Step 1. Turn off the server. Then, disconnect all external cables and remove all peripheral devices.

Step 2. Remove the server cover. See “Removing the server cover” on page 88.

Step 3. Remove the PCI riser-card assembly. See “Removing the PCI riser-card assembly” on page 93.

Step 4. Disconnect the operating temperature enhancement kit connector from the system board.

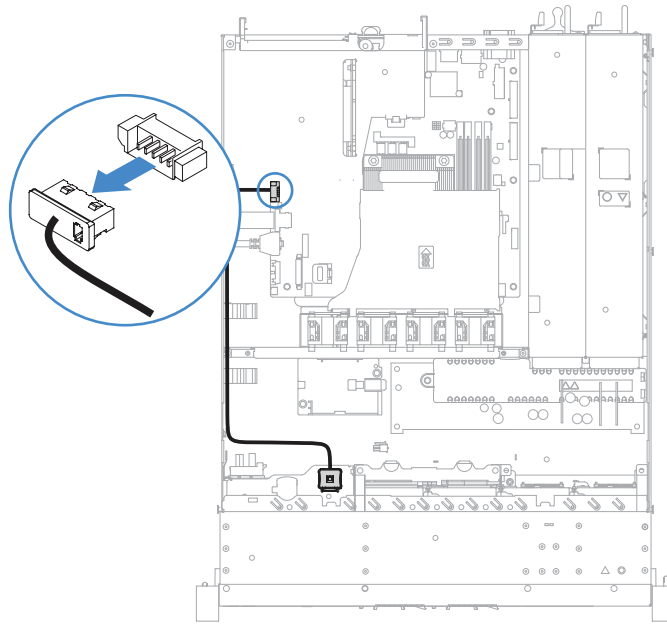

Figure 55. Operating temperature enhancement kit cable disconnection for 2.5-inch-drive model

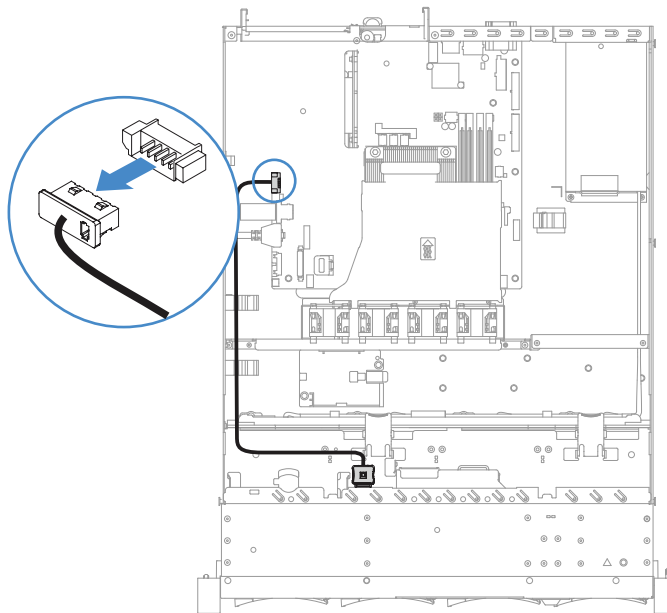

Figure 56. Operating temperature enhancement kit cable disconnection for 3.5-inch-drive model

Step 5. Detach the operating temperature enhancement kit **1** from the slot **2** on the hard disk drive cage.

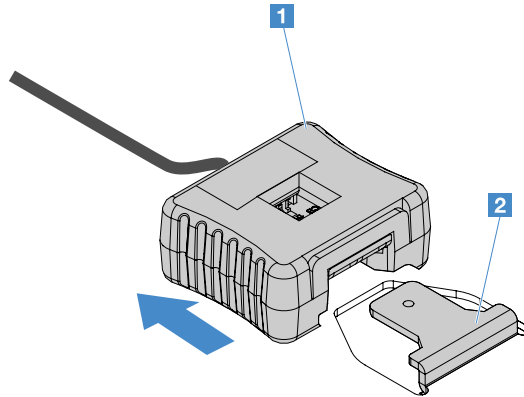

Figure 57. Operating temperature enhancement kit removal

Step 6. Complete the parts replacement. See “Completing the parts replacement” on page 172.

Installing the operating temperature enhancement kit

To install the operating temperature enhancement kit, do the following:

- Step 1. Turn off the server. Then, disconnect all external cables and remove all peripheral devices.
- Step 2. Remove the server cover. See “Removing the server cover” on page 88.
- Step 3. Remove the PCI riser-card assembly. See “Removing the PCI riser-card assembly” on page 93.
- Step 4. Connect the operating temperature enhancement kit connector to the system board.
- Step 5. Route the cable along the chassis. Make sure the relevant cables pass through the cable clips.

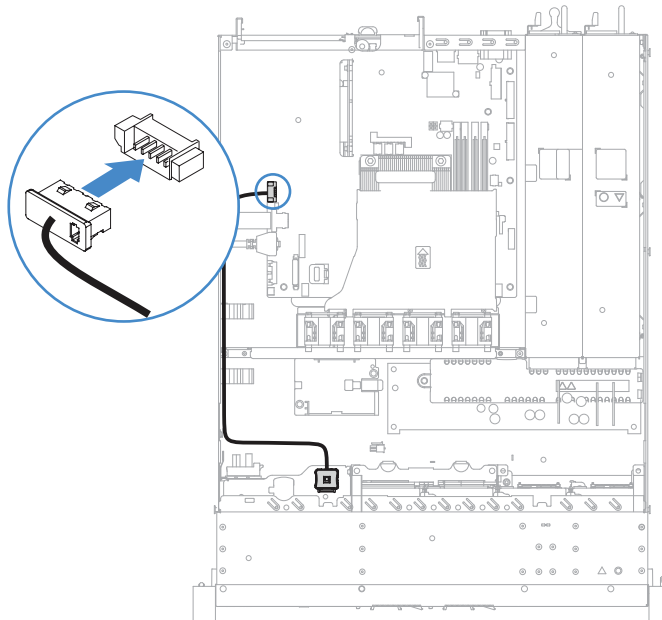

Figure 58. Operating temperature enhancement kit cable connection for 2.5-inch-drive model

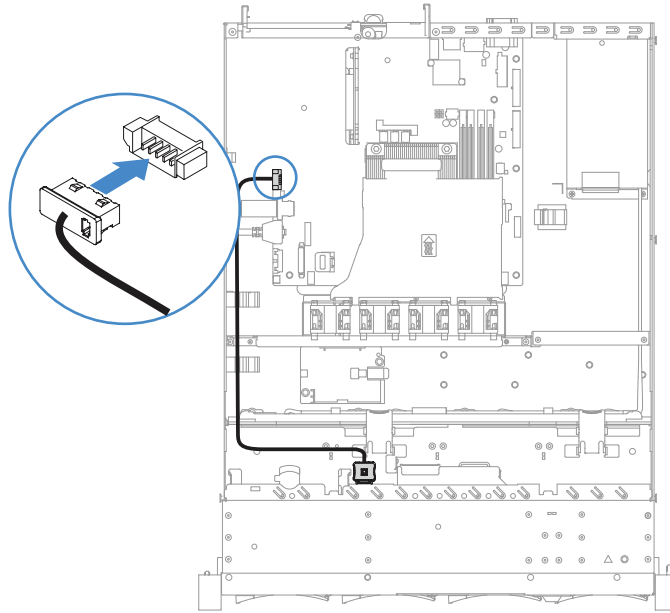

Figure 59. Operating temperature enhancement kit cable connection for 3.5-inch-drive model

Attention: Make sure that the cable is not pinched and does not cover any connectors or obstruct any components on the system board.

- Step 6. Slide the operating temperature enhancement kit **1** into the slot **2** on the hard disk drive cage until the operating temperature enhancement kit locks into place with an audible click.

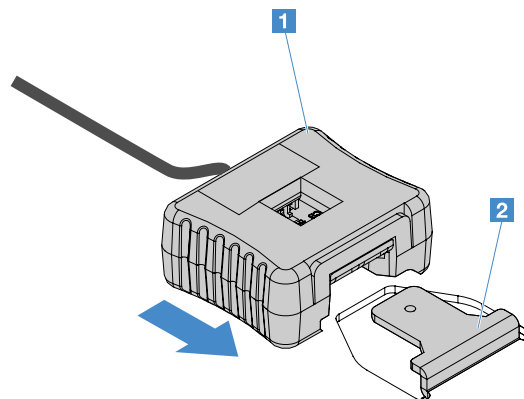

Figure 60. Operating temperature enhancement kit installation

- Step 7. Complete the parts replacement. See “Completing the parts replacement” on page 172.

Removing a system fan

To remove a system fan, do the following:

- Step 1. Check the IMM2 event log to find out which fan needs to be replaced. Refer to Appendix A “Integrated Management Module II (IMM2) error messages” on page 175 for the error messages.
- Step 2. Turn off the server. Then, disconnect all external cables and remove all peripheral devices.
- Step 3. Remove the server cover. See “Removing the server cover” on page 88.

- Step 4. Remove the air baffle. See “Removing the air baffle” on page 90.
- Step 5. Disconnect the fan cable from the system board. Record the routing of the fan cable; you will have to route the fan cable the same way when you install the fan.
- Step 6. Grasp the top of the fan with your index finger and thumb and lift the fan out of the server.

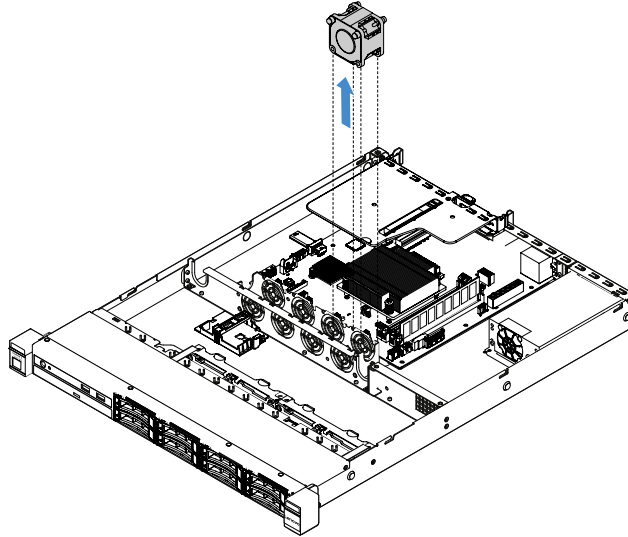

Figure 61. System fan removal

- Step 7. Complete the parts replacement. See “Completing the parts replacement” on page 172.

Installing a system fan

To install a system fan, do the following:

- Step 1. Turn off the server. Then, disconnect all external cables and remove all peripheral devices.
- Step 2. Remove the server cover. See “Removing the server cover” on page 88.
- Step 3. Remove the air baffle. See “Removing the air baffle” on page 90.
- Step 4. Position the new fan so that the airflow arrow on the fan points toward the rear of the server.

Note: The correct airflow is from the front to the rear of the server.

- Step 5. Insert the fan into the bracket. Then, route the fan cable into the fan cable slot in the fan bracket. Make sure that each of the gray soft tabs on the fan is fully seated in its slot in the fan bracket.

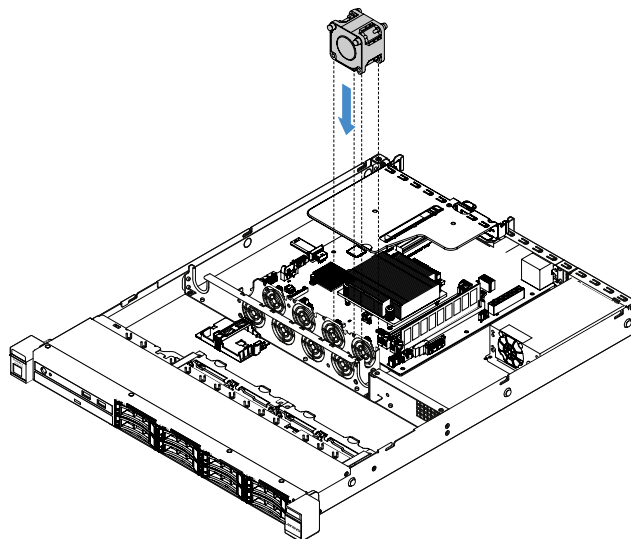

Figure 62. System fan installation

- Step 6. Connect the new fan cable to the system board. To locate the fan connectors on the system board, see “System-board connectors” on page 21.
- Step 7. Complete the parts replacement. See “Completing the parts replacement” on page 172.

Removing the coin-cell battery

The following tips describe information that you must consider when removing the coin-cell battery.

- Lenovo has designed this product with your safety in mind. The lithium coin-cell battery must be handled correctly to avoid possible danger. If you replace the coin-cell battery, you must adhere to the following instructions.

Note: In the U.S., call 1-800-IBM-4333 for information about battery disposal.

- If you replace the original lithium battery with a heavy-metal battery or a battery with heavy-metal components, be aware of the following environmental consideration. Batteries and accumulators that contain heavy metals must not be disposed of with normal domestic waste. They will be taken back free of charge by the manufacturer, distributor, or representative, to be recycled or disposed of in a proper manner.
- To order replacement batteries, call 1-800-IBM-SERV within the U.S., and 1-800-465-7999 or 1-800-465-6666 within Canada. Outside the U.S. and Canada, call your support center or business partner.

Note: After you replace the coin-cell battery, you must reconfigure the server and reset the system date and time.



CAUTION:

When replacing the lithium battery, use only Part Number 33F8354 or an equivalent type battery

recommended by the manufacturer. If your system has a module containing a lithium battery, replace it only with the same module type made by the same manufacturer. The battery contains lithium and can explode if not properly used, handled, or disposed of.

Do not:

- **Throw or immerse into water**
- **Heat to more than 100°C (212°F)**
- **Repair or disassemble**

Dispose of the battery as required by local ordinances or regulations.

Note: After you remove the coin-cell battery, you need to install a new one. See “Installing the coin-cell battery” on page 127.

To remove the coin-cell battery, do the following:

- Step 1. Turn off the server. Then, disconnect all external cables and remove all peripheral devices.
- Step 2. Remove the server cover. See “Removing the server cover” on page 88.
- Step 3. If necessary, remove the air baffle. See “Removing the air baffle” on page 90.
- Step 4. Locate the coin-cell battery, see “System-board connectors” on page 21.
- Step 5. Remove the coin-cell battery.

Attention:

- Failing to remove the coin-cell battery properly might damage the socket on the system board. Any damage to the socket might require replacing the system board.
- Do not tilt or push the coin-cell battery by using excessive force.

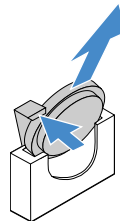

Figure 63. Coin-cell battery removal

- Step 6. Dispose of the coin-cell battery as required by local ordinances or regulations. For more information, see the *Environmental Notices and User's Guide* on the documentation CD.

Installing the coin-cell battery

The following tips describe information that you must consider when installing the coin-cell battery.

- Follow any special handling and installation instructions that come with the coin-cell battery.
- Lenovo has designed this product with your safety in mind. The lithium battery must be handled correctly to avoid possible danger. If you install the coin-cell battery, you must adhere to the following instructions.

Note: In the U. S., call 1-800-IBM-4333 for information about battery disposal.

- If you replace the original lithium battery with a heavy-metal battery or a battery with heavy-metal components, be aware of the following environmental consideration. Batteries and accumulators that

contain heavy metals must not be disposed of with normal domestic waste. They will be taken back free of charge by the manufacturer, distributor, or representative, to be recycled or disposed of in a proper manner.

- To order replacement batteries, call 1-800-IBM-SERV within the U.S., and 1-800-465-7999 or 1-800-465-6666 within Canada. Outside the U.S. and Canada, call your support center or business partner.

Note: After you install the coin-cell battery, you must reconfigure the server and reset the system date and time.



CAUTION:

When installing the lithium battery, use only Part Number 33F8354 or an equivalent type battery recommended by the manufacturer. If your system has a module containing a lithium battery, install it only with the same module type made by the same manufacturer. The battery contains lithium and can explode if not properly used, handled, or disposed of.

Do not:

- **Throw or immerse into water**
- **Heat to more than 100°C (212°F)**
- **Repair or disassemble**

Dispose of the battery as required by local ordinances or regulations.

To install the coin-cell battery, do the following:

Step 1. Install the new coin-cell battery. Ensure that the coin-cell battery retainer holds the battery securely.

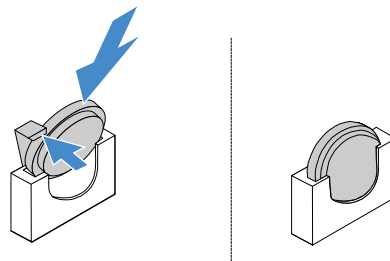

Figure 64. Coin-cell battery installation

Step 2. Complete the parts replacement. See “Completing the parts replacement” on page 172.

Step 3. Start Setup Utility and reset the configuration:

- a. Set the system date and time.
- b. Set the power-on password.
- c. Reconfigure the server.

For more information, see “Starting the Setup Utility program” on page 29.

Removing the fixed power supply

When you remove the fixed power supply, observe the following precautions.



CAUTION:

Never remove the cover on a power supply or any part that has the following label attached.



Hazardous voltage, current, and energy levels are present inside any component that has this label attached. There are no serviceable parts inside these components. If you suspect a problem with one of these parts, contact a service technician.

Note: After you remove the fixed power supply, you need to install a new one. See “Installing the fixed power supply” on page 130.

To remove the fixed power supply, do the following:

- Step 1. Turn off the server. Then, disconnect all external cables and remove all peripheral devices.
- Step 2. Remove the server cover. See “Removing the server cover” on page 88.
- Step 3. Disconnect the power-supply cables from the connectors on the system board and internal devices. Then, disengage the cables from any retention clips.

Note: Record the routing of all power-supply cables; you will route the power-supply cables the same way when you install the power supply.

- Step 4. Remove the fixed power supply.
 - a. Remove the screws that secure the power supply to the rear of the chassis.
 - b. Push the power supply toward the front of the server until the power supply has disengaged from the chassis.
 - c. Lift the power supply out of the chassis.

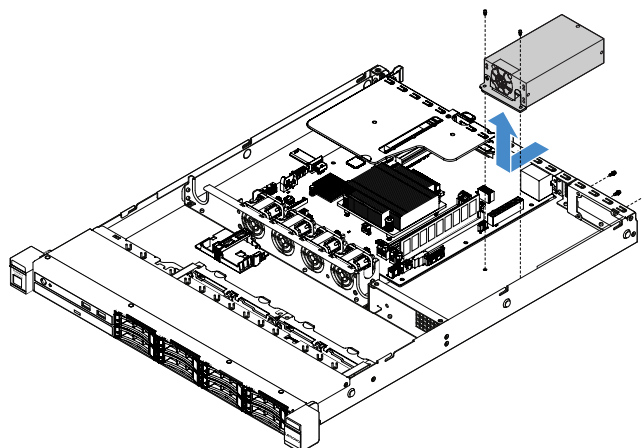

Figure 65. Fixed power supply removal

Installing the fixed power supply

When you install the fixed power supply, observe the following precautions.



CAUTION:

Never remove the cover on a power supply or any part that has the following label attached.



Hazardous voltage, current, and energy levels are present inside any component that has this label attached. There are no serviceable parts inside these components. If you suspect a problem with one of these parts, contact a service technician.

To install the fixed power supply, do the following:

- Step 1. Install the fixed power supply.
- Position the power supply on the chassis.
 - Push the power supply toward the rear of the server until the power supply engages the chassis.
 - Install the screws to secure the power supply to the chassis.

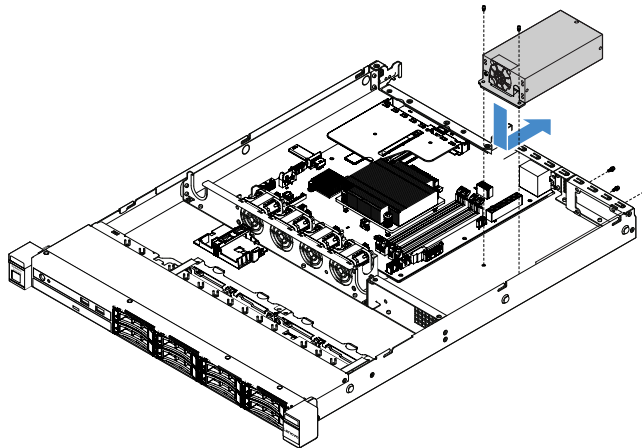

Figure 66. Fixed power supply installation

- Step 2. Connect the internal power-supply cables from the power supply to the power supply connector and CPU power connector on the system board. To locate the power connectors on the system board, see “System-board connectors” on page 21.
- Step 3. Route the internal power-supply cables, securing them with the retention clips.
- Step 4. Test the power supply:
- Connect one end of the ac power cord for the new power supply into the power supply connector, and connect the other end of the power cord into a properly grounded electrical outlet. Make sure that the standby power LED on the system board is lit. See “System-board LEDs” on page 24.
 - If the standby power LED is not lit, discontinue this procedure and obtain a new power supply.
 - Press the power-control button. Make sure that the power-on LED on the front of the server is lit.
- If the server starts, proceed to the next step. If the server does not start, disconnect the ac power cord and call for service.
- Step 5. Turn off the server and disconnect the ac power cord.
- Step 6. Complete the parts replacement. See “Completing the parts replacement” on page 172.
- Step 7. Press the power-control button. Make sure that the power-on LED on the front of the server is lit.

Removing a hot-swap power supply

When you remove a power supply, observe the following precautions.



CAUTION:

The power control button on the device and the power switch on the power supply do not turn off the electrical current supplied to the device. The device also might have more than one power cord. To remove all electrical current from the device, ensure that all power cords are disconnected from the power source.

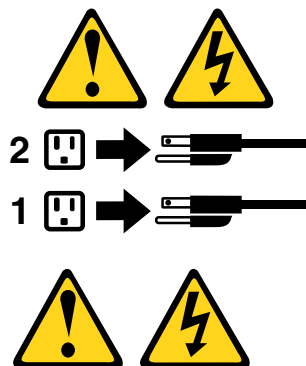

CAUTION:

Never remove the cover on a power supply or any part that has the following label attached.



Hazardous voltage, current, and energy levels are present inside any component that has this label attached. There are no serviceable parts inside these components. If you suspect a problem with one of these parts, contact a service technician.

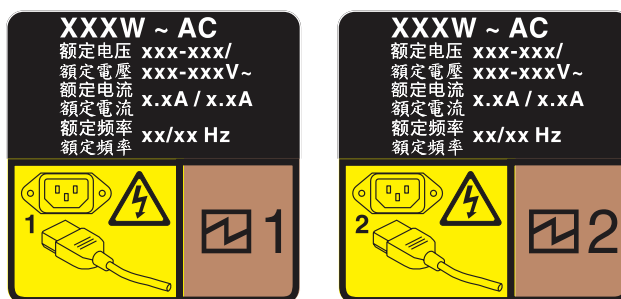

Figure 67. Hot-swap power supply label on the cover

To remove a hot-swap power supply, do the following:

Attention: This type of power supply is hot-swap only when two power supplies are installed for redundancy. If only one power supply is installed, you must turn off the server first before removing the power supply.

Step 1. If the server is in a rack, pull back the cable management arm to gain access to the rear of the server and the power supply.

- Step 2. Disconnect the power cord from the hot-swap power supply.
- Step 3. Press the release tab toward the handle and carefully pull the handle at the same time to slide the hot-swap power supply out of the chassis.

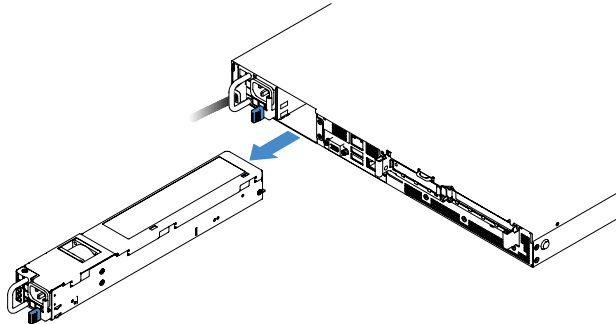

Figure 68. Hot-swap power supply removal

- Step 4. Install the power-supply filler or a new power supply to cover the power supply bay. See “Installing a hot-swap power supply” on page 133.

Installing a hot-swap power supply

The following tips describe the type of power supply that the server supports and other information that you must consider when you install a power supply:

- For 460-watt power-supply server models, the standard shipping has only one 460-watt power supply installed in the server. For redundancy and hot-swap support, you must install an additional 460-watt hot-swap power supply. Certain customized models might be shipped with two power supplies installed.
- Make sure that the devices that you are installing are supported. For a list of supported optional devices for the server, go to <http://www.lenovo.com/serverproven/>.

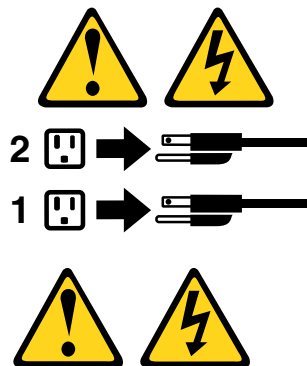

CAUTION:
Never remove the cover on a power supply or any part that has the following label attached.

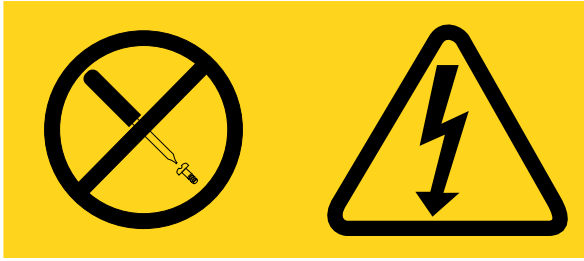

Hazardous voltage, current, and energy levels are present inside any component that has this label attached. There are no serviceable parts inside these components. If you suspect a problem with one of these parts, contact a service technician.

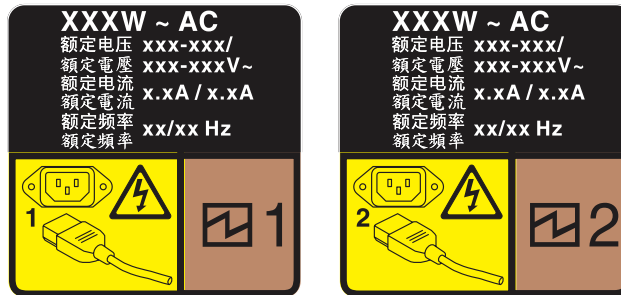

Figure 69. Hot-swap power supply label on the cover

To install a hot-swap power supply, do the following:

- Step 1. Remove the power-supply filler. Then, slide the hot-swap power supply into the bay until the release latch clicks into place.

Important: To ensure proper cooling during normal server operation, both of the power supply bays must be occupied. This means that each bay must have a power supply installed; or one has a power supply installed and the other has a power-supply filler installed.

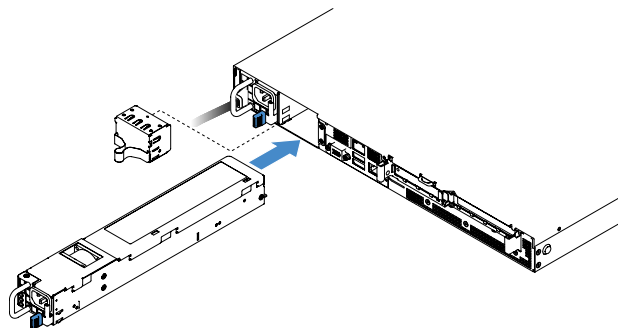

Figure 70. Hot-swap power supply installation

- Step 2. Connect one end of the power cord to the new power supply connector; then, connect the other end of the power cord into a properly grounded electrical outlet.
- Step 3. If the server is turned off, turn on the server. Make sure that the ac power LED on the power supply is lit, indicating that the power supply is operating properly. If the server is turned on, make sure that the dc power LED on the power supply is lit also.

Removing the PCI riser card from the PCI riser-card assembly

To remove the PCI riser card from the PCI riser-card assembly, do the following:

- Step 1. Turn off the server. Then, disconnect all external cables and remove all peripheral devices.
- Step 2. Remove the server cover. See “Removing the server cover” on page 88.
- Step 3. Remove the PCI riser-card assembly. See “Removing the PCI riser-card assembly” on page 93.
- Step 4. Remove the screws that secure the PCI riser card to the riser card bracket. Then, remove the PCI riser card.

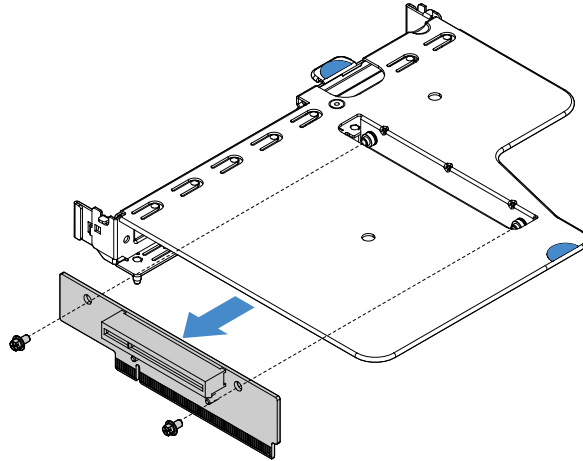

Figure 71. PCI riser card removal

- Step 5. Install a new PCI riser card to the PCI riser-card assembly. See “Installing the PCI riser card to the PCI riser-card assembly” on page 135.

Installing the PCI riser card to the PCI riser-card assembly

If you have removed PCI riser card from the PCI riser-card assembly, install a new PCI riser card to the PCI riser-card assembly before turning on the server.

To install the PCI riser card to the PCI riser-card assembly, do the following:

- Step 1. Align the holes in the PCI riser card with the holes in the riser-card bracket. Then, install the screws to secure the PCI riser card to the riser-card bracket.

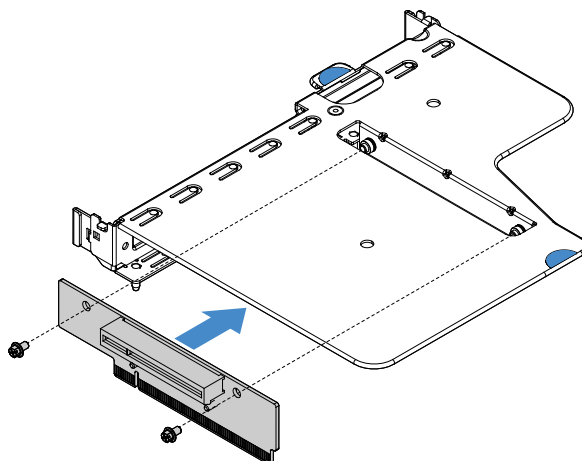

Figure 72. PCI riser-card bracket installation

- Step 2. If needed, install an adapter. See “Installing an adapter” on page 111. Then, connect the cables for the adapter.
- Step 3. Reinstall the PCI riser-card assembly. See “Installing the PCI riser-card assembly” on page 94.
- Step 4. Complete the parts replacement. See “Completing the parts replacement” on page 172.

Removing the 2.5-inch hot-swap hard-disk-drive backplane

Note: After you remove the 2.5-inch hot-swap hard-disk-drive backplane, you need to install a new one. See “Installing the 2.5-inch hot-swap hard-disk-drive backplane” on page 137.

To remove the 2.5-inch hot-swap hard-disk-drive backplane, do the following:

- Step 1. Turn off the server. Then, disconnect all external cables and remove all peripheral devices.
- Step 2. Remove the server cover. See “Removing the server cover” on page 88.
- Step 3. Remove the hard disk drives or fillers out of the server. See “Removing a hot-swap hard disk drive” on page 100.
- Step 4. Disconnect all cables from the hard-disk-drive backplane.

Step 5. Lift the blue tabs on the backplane to disengage and remove the backplane from the chassis.

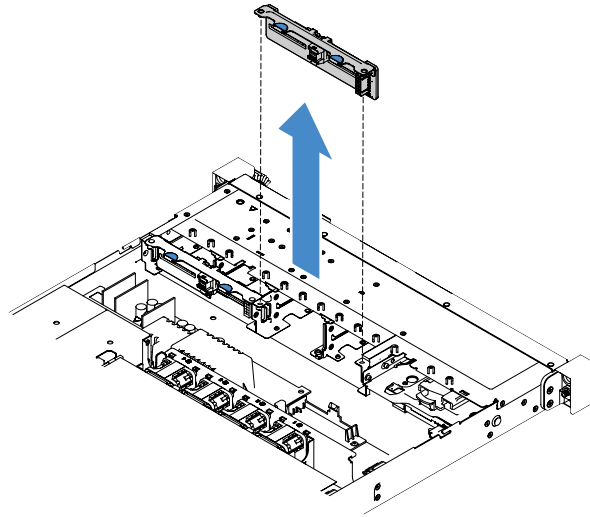

Figure 73. 2.5-inch hot-swap hard-disk-drive backplane removal

Installing the 2.5-inch hot-swap hard-disk-drive backplane

The following illustration shows contents of the second 2.5-inch hard-disk-drive backplane upgrade kit:

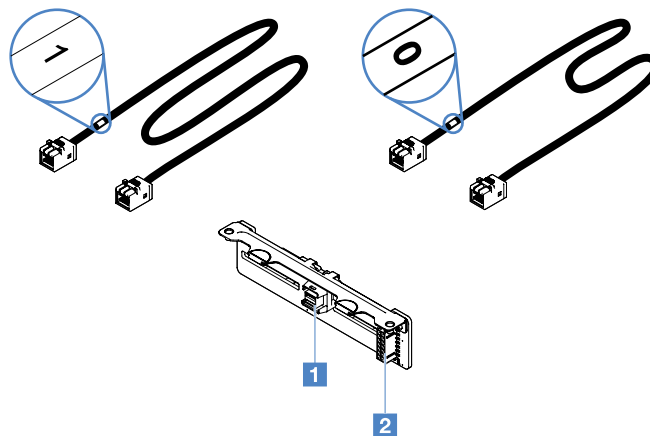

Figure 74. The second 2.5-inch hard-disk-drive backplane upgrade kit

1 Mini-SAS signal cable connector

2 Power connector

To install the 2.5-inch hot-swap hard-disk-drive backplane, do the following:

- Step 1. Align the backplane with the backplane alignment slots in the chassis. Then, carefully lower the hard-disk-drive backplane until it is fully seated in the chassis.

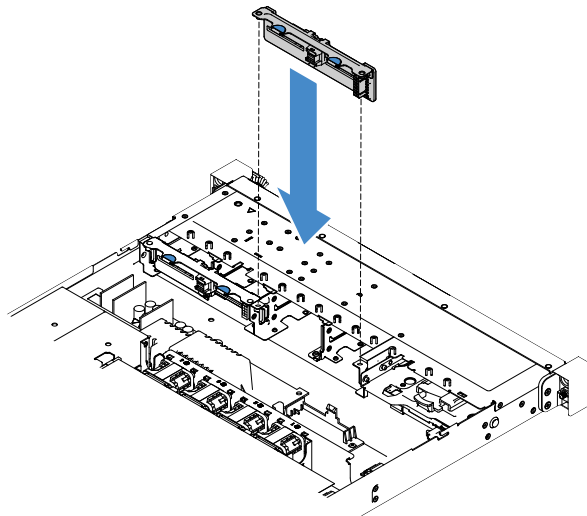

Figure 75. 2.5-inch hot-swap hard-disk-drive backplane installation

- Step 2. Reconnect all cables that you removed from the hard-disk-drive backplane.
- Step 3. If you need to install the second backplane, repeat step 4.
- Step 4. Install a RAID adapter. See “Installing an adapter” on page 111.
- Step 5. Connect power and signal cables. Refer to the following topics:
- “Hot-swap HDD cable connection: ServeRAID SAS/SATA controller and hot-swap power supply ” on page 168
 - “Hot-swap HDD cable connection: ServeRAID SAS/SATA controller and fixed power supply” on page 164
- Step 6. Reinstall the hard disk drives and fillers. See “Installing a hot-swap hard disk drive” on page 101.
- Step 7. Complete the parts replacement. See “Completing the parts replacement” on page 172.

Removing the 2.5-inch simple-swap hard-disk-drive backplate assembly

Note: After you remove the 2.5-inch simple-swap hard-disk-drive backplate assembly, you need to install a new one. See “Installing the 2.5-inch simple-swap hard-disk-drive backplate assembly” on page 139.

To remove the 2.5-inch simple-swap hard-disk-drive backplate assembly, do the following:

- Step 1. Turn off the server. Then, disconnect all external cables and remove all peripheral devices.
- Step 2. Remove the server cover. See “Removing the server cover” on page 88.
- Step 3. Remove the PCI riser-card assembly if installed. See “Removing the PCI riser-card assembly” on page 93.
- Step 4. Disconnect the cables from the RAID adapter or system board. See “Internal cable routing” on page 158. Then, remove the corresponding cables from the cable clips.
- Step 5. Remove the installed hard disk drives or fillers from the drive bays. See “Removing a simple-swap hard disk drive” on page 103.
- Step 6. Grasp the blue tabs on the backplate assembly to lift the backplate assembly from the chassis.

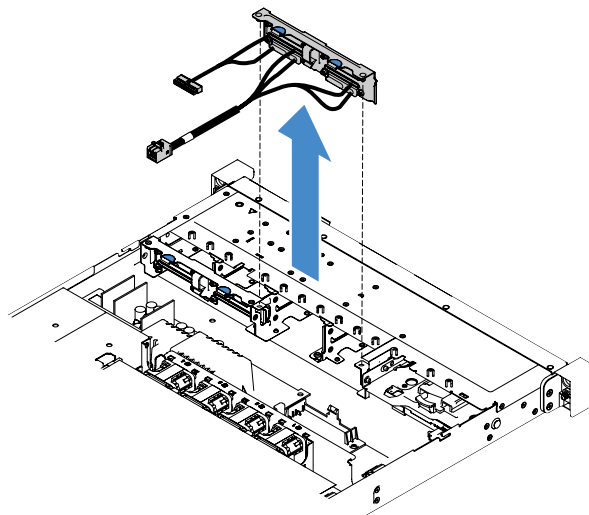

Figure 76. 2.5-inch simple-swap hard-disk-drive backplate assembly removal

Installing the 2.5-inch simple-swap hard-disk-drive backplate assembly

There are three types of 2.5-inch simple-swap hard-disk-drive backplate assemblies. In the following illustrations, type a and b are for server models with RAID adapters and type c is for server models with onboard software RAID configuration.

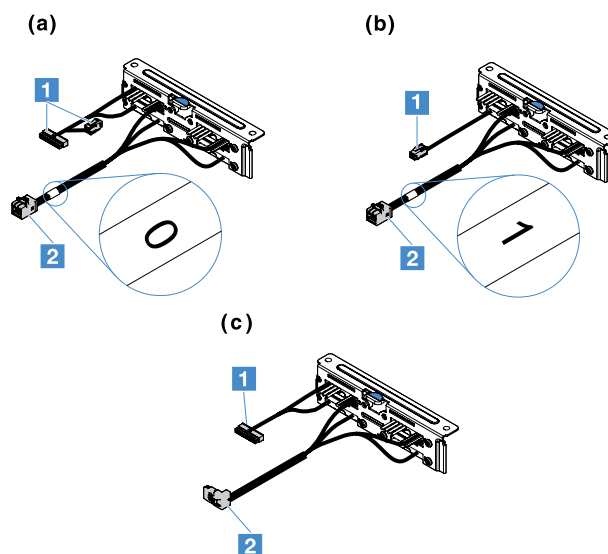

Figure 77. 2.5-inch simple-swap hard-disk-drive backplate assemblies

1 Power connector

2 Mini-SAS signal connector

To install the 2.5-inch simple-swap hard-disk-drive backplate assembly, do the following:

Step 1. Align the backplate assembly with the backplate assembly alignment slots in the chassis. Then, carefully lower the backplate assembly into the chassis until it is seated firmly.

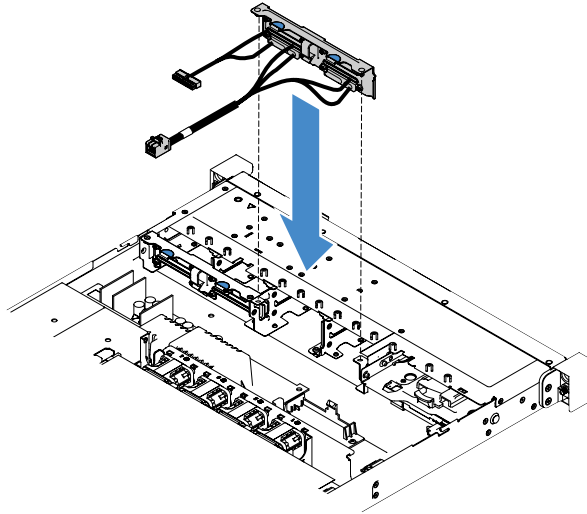

Figure 78. 2.5-inch simple-swap hard-disk-drive backplate assembly installation

- Step 2. Connect the cables to the RAID adapter or system board. Refer to the following topics:
- “Simple-swap HDD cable connection: onboard RAID” on page 162
 - “Simple-swap HDD cable connection: ServeRAID SAS/SATA controller and fixed power supply” on page 166
 - “Simple-swap HDD cable connection: ServeRAID SAS/SATA controller and redundant power supply” on page 170

Step 3. Reinstall the hard disk drives or fillers. See “Installing a simple-swap hard disk drive” on page 105.

Step 4. Complete the parts replacement. See “Completing the parts replacement” on page 172.

Removing the 3.5-inch hot-swap hard-disk-drive backplane

Note: After you remove the 3.5-inch hot-swap hard-disk-drive backplane, you need to install a new one. See “Installing the 3.5-inch hot-swap hard-disk-drive backplane” on page 141.

To remove the 3.5-inch hot-swap hard-disk-drive backplane, do the following:

- Step 1. Turn off the server. Then, disconnect all external cables and remove all peripheral devices.
- Step 2. Remove the server cover. See “Removing the server cover” on page 88.
- Step 3. Remove the PCI riser-card assembly if installed. See “Removing the PCI riser-card assembly” on page 93.
- Step 4. Remove the installed hard disk drives or fillers from the drive bays. See “Removing a hot-swap hard disk drive” on page 100.

Step 5. Pivot the retention latches on the chassis as shown in the following illustration. Then, carefully pull the backplane assembly outwards and lift it up to remove it out of the chassis.

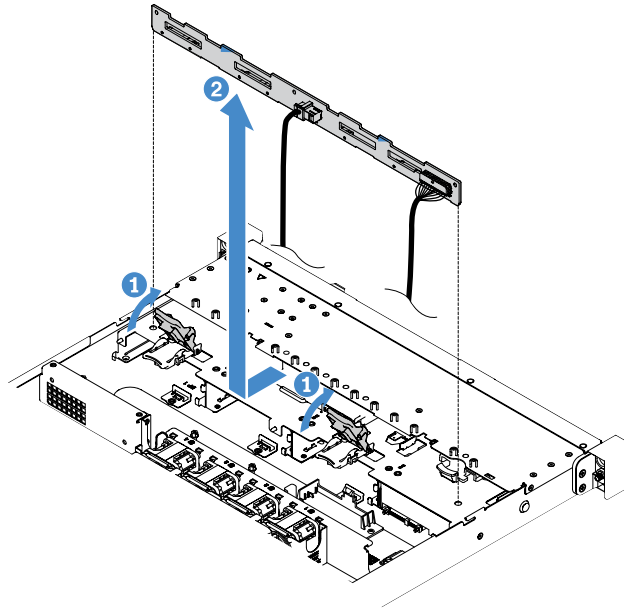

Figure 79. 3.5-inch hot-swap hard-disk-drive backplane removal

Step 6. Disconnect all cables from the hard-disk-drive backplane.

Installing the 3.5-inch hot-swap hard-disk-drive backplane

To install the 3.5-inch hot-swap hard-disk-drive backplane, do the following:

Step 1. Connect cables to the hard-disk-drive backplane.

- Step 2. Carefully lower the backplane assembly into the alignment slots in the chassis. Then, close the retention latches to secure the backplane to the chassis.

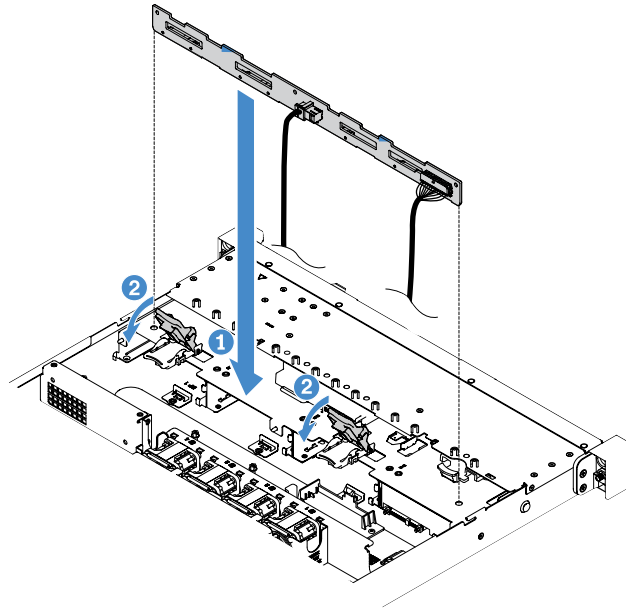

Figure 80. 3.5-inch hot-swap hard-disk-drive backplane installation

- Step 3. Connect all cables to the system board or RAID adapter. See “Hot-swap HDD cable connection: ServeRAID SAS/SATA controller and fixed power supply” on page 164.
- Step 4. Install the hard disk drives and fillers. See “Installing a hot-swap hard disk drive” on page 101.
- Step 5. Complete the parts replacement. See “Completing the parts replacement” on page 172.

Removing the 3.5-inch simple-swap hard-disk-drive backplate assembly

Note: After you remove the 3.5-inch simple-swap hard-disk-drive backplate assembly, you need to install a new one. See “Installing the 3.5-inch simple-swap hard-disk-drive backplate assembly” on page 144.

To remove the 3.5-inch simple-swap hard-disk-drive backplate assembly, do the following:

- Step 1. Turn off the server. Then, disconnect all external cables and remove all peripheral devices.
- Step 2. Remove the server cover. See “Removing the server cover” on page 88.
- Step 3. Remove the PCI riser-card assembly if installed. See “Removing the PCI riser-card assembly” on page 93.
- Step 4. Disconnect the cables from the RAID adapter or system board. See “Internal cable routing” on page 158. Then, remove the corresponding cables from the cable clips.
- Step 5. Remove the installed hard disk drives or fillers from the drive bays. See “Removing a simple-swap hard disk drive” on page 103.

Step 6. Pivot the retention latches on the chassis upward. Then, carefully pull the backplate assembly outwards and lift it up to remove it out of the chassis.

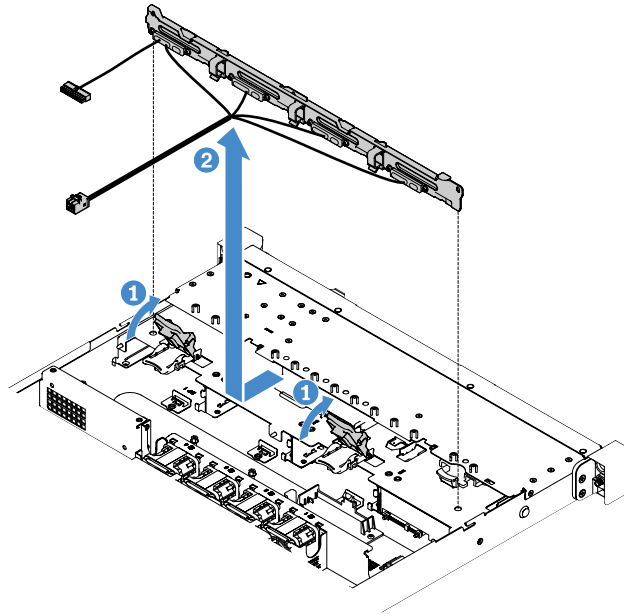

Figure 81. 3.5-inch simple-swap hard-disk-drive backplate assembly removal

Installing the 3.5-inch simple-swap hard-disk-drive backplate assembly

There are two types of 3.5-inch simple-swap hard-disk-drive backplate assemblies. In the following illustration, type b is for server models with onboard software RAID configuration.

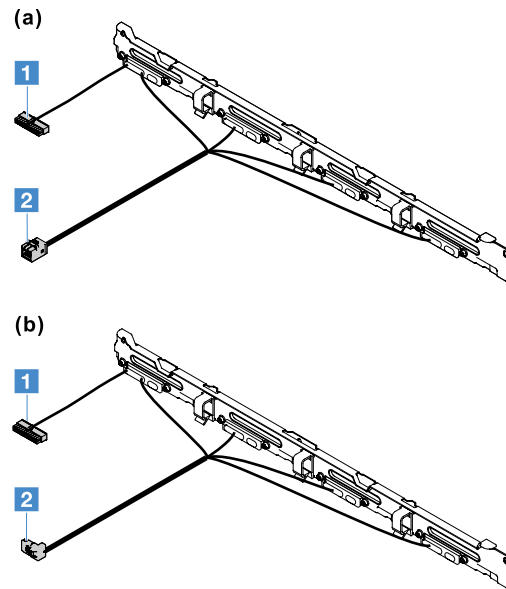

Figure 82. 3.5-inch simple-swap hard-disk-drive backplate assemblies

- 1** Power connector
- 2** Mini-SAS signal connector

To install the 3.5-inch simple-swap hard-disk-drive backplate assembly, do the following:

Step 1. Carefully lower the backplate assembly into the alignment slots in the chassis. Then, close the retention latches to secure the backplate assembly to the chassis.

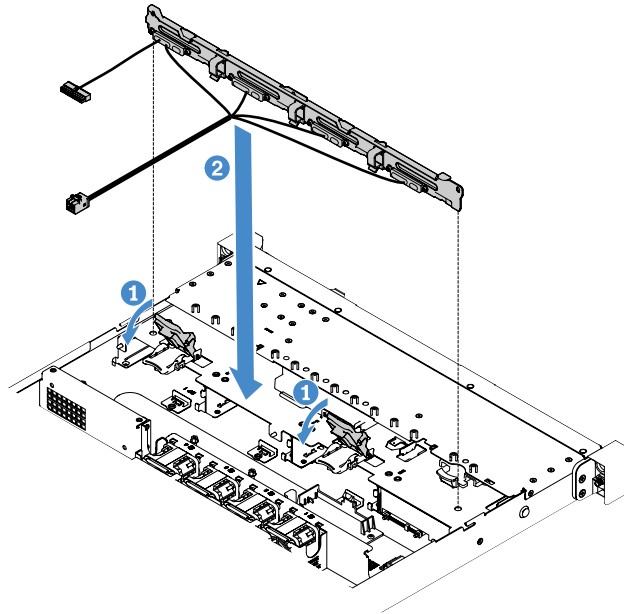

Figure 83. 3.5-inch simple-swap hard-disk-drive backplate assembly installation

Step 2. Connect cables to the RAID adapter or system board. Refer to the following topics:

- “Simple-swap HDD cable connection: onboard RAID” on page 162
- “Simple-swap HDD cable connection: ServeRAID SAS/SATA controller and redundant power supply” on page 170
- “Simple-swap HDD cable connection: ServeRAID SAS/SATA controller and fixed power supply” on page 166

Step 3. Install the hard disk drives and fillers. See “Installing a simple-swap hard disk drive” on page 105.

Step 4. Complete the parts replacement. See “Completing the parts replacement” on page 172.

Removing and installing Tier 2 CRUs

This section provides information about removing and installing Tier 2 CRUs.

You may install a Tier 2 CRU yourself or request Lenovo to install it, at no additional charge, under the type of warranty service that is designated for your server. The illustrations in this document might differ slightly from your hardware.

Removing the microprocessor and heat sink (Trained technician only)

The following notes describe the type of microprocessor that the server supports and other information that you must consider when you install or remove a microprocessor and heat sink:

- The server supports one Intel land grid array (LGA) 1151 dual-core or quad-core microprocessor. The type, speed, and L3 cache of the microprocessor depends on the server model.
- Read the documentation that comes with the microprocessor to determine whether you have to update the server firmware. To download the most current level of server firmware, go to <http://www.lenovo.com/support> and <http://www.ibm.com/support/fixcentral>.

- The microprocessor uses an integrated voltage regulator on the system board.

Attention:

- Do not allow the thermal grease on the microprocessor and heat sink to come in contact with anything. Contact with any surface can compromise the thermal grease and the microprocessor socket.
- Dropping the microprocessor during installation or removal can damage the contacts.
- Do not touch the microprocessor contacts; handle the microprocessor by the edges only. Contaminants on the microprocessor contacts, such as oil from your skin, can cause connection failures between the contacts and the socket.
- The pins on the sockets are fragile. Any damage to the pins might require replacing the system board.
- Removing the heat sink from the microprocessor destroys the even distribution of the thermal grease, you must wipe off the thermal grease with the alcohol wipes and reapply clean thermal grease. See “Thermal grease” on page 150.
- After you remove a new microprocessor or a new heat sink, you need to install a new one. See “Installing the microprocessor and heat sink (Trained technician only)” on page 148.

To remove the microprocessor and heat sink, do the following:

Step 1. Turn off the server. Then, disconnect all external cables and remove all peripheral devices.

Step 2. Remove the server cover. See “Removing the server cover” on page 88.

Step 3. Remove the air baffle. See “Removing the air baffle” on page 90.

Step 4. Remove the heat sink.

CAUTION:



The heat sink might become very hot during normal operation. Allow time for the heat sink to cool down before you touch it.

- a. Use a screwdriver to loosen the captive screws **1** by rotating screws until each screw is loose.
- b. Alternate among the screws until they break the seal with the microprocessor.
- c. Gently twist the heat sink to free it from the microprocessor and then lift the heat sink off the system board.

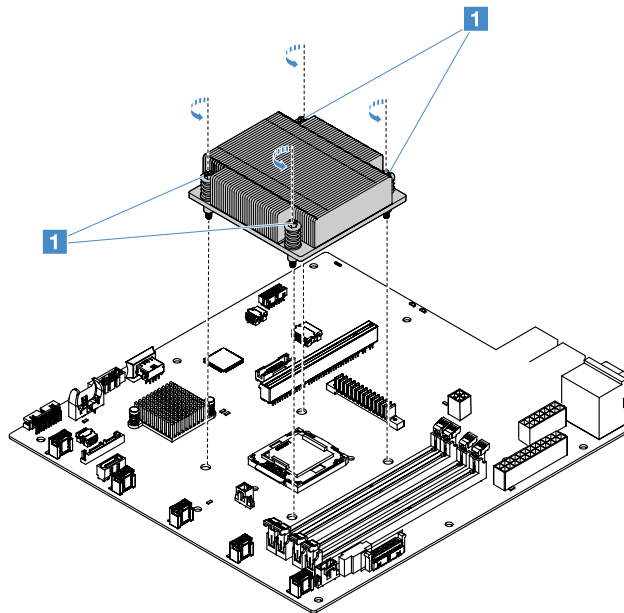

Figure 84. Heat sink removal

Step 5. Place the heat sink on its side on a clean, flat surface after removal.

Step 6. Remove the microprocessor.

- a. Open the microprocessor retention latch by gently pressing down the handle a little bit and then pushing the handle outward.
- b. Open the microprocessor bracket. Keep the bracket in the open position.
- c. Hold the microprocessor by its edges and carefully lift the microprocessor straight up and out of the socket.

Attention: Handle the microprocessor carefully. Dropping the microprocessor during removal can damage the contacts. In addition, contaminants on the microprocessor contacts, such as oil from your skin, can cause connection failures between the contacts and the socket.

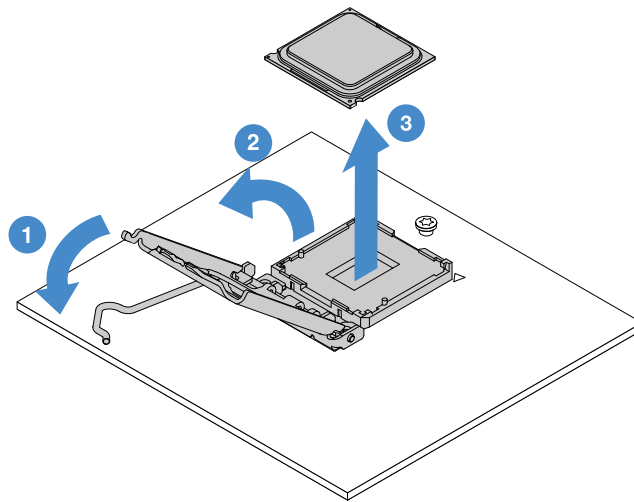

Figure 85. Microprocessor removal

Step 7. Place the microprocessor on a static-protective surface.

Attention: The pins on the sockets are fragile. Any damage to the pins might require replacing the system board.

Installing the microprocessor and heat sink (Trained technician only)

The following notes describe the type of microprocessor that the server supports and other information that you must consider when you install a microprocessor and heat sink:

- The server supports one Intel land grid array (LGA) 1151 dual-core or quad-core microprocessor. The type, speed, and L3 cache of the microprocessor depends on the server model.
- Read the documentation that comes with the microprocessor to determine whether you have to update the server firmware. To download the most current level of server firmware, go to <http://www.lenovo.com/support> and <http://www.ibm.com/support/fixcentral>.
- The microprocessor uses an integrated voltage regulator on the system board.
- The microprocessor speeds are automatically set for this server; therefore, you do not have to set any microprocessor frequency-selection jumpers or switches.
- If the thermal-grease protective cover (for example, a plastic cap or tape liner) is removed from the heat sink, do not touch the thermal grease on the bottom of the heat sink or set down the heat sink. For more information about applying or working with thermal grease, see “Thermal grease” on page 150.

Note: Removing the heat sink from the microprocessor destroys the even distribution of the thermal grease and requires reapplying the thermal grease.

Attention:

- Do not allow the thermal grease on the microprocessor and heat sink to come in contact with anything. Contact with any surface can compromise the thermal grease and the microprocessor socket.
- Dropping the microprocessor during installation or removal can damage the contacts.
- The microprocessor contacts are fragile. Do not touch the microprocessor contacts; handle the microprocessor by the edges only. Contaminants on the microprocessor contacts, such as oil from your skin, can cause connection failures between the contacts and the socket.
- The pins on the sockets are fragile. Any damage to the pins might require replacing the system board.
- When you handle static-sensitive devices, take precautions to avoid damage from static electricity. For details about handling these devices, see “Handling static-sensitive devices” on page 88.
- The microprocessor fits only one way on the socket.
- Removing the heat sink from the microprocessor destroys the even distribution of the thermal grease, you must wipe off the thermal grease with the alcohol wipes and reapply clean thermal grease. See “Thermal grease” on page 150.

To install the microprocessor and heat sink, do the following:

Step 1. Install the microprocessor.

- a. Align the microprocessor with the socket (note the alignment marks **1** and the position of the notches) and carefully place the microprocessor on the socket.
- b. Close the microprocessor bracket frame.
- c. Close the microprocessor retention latch by securing the handle back to its position.

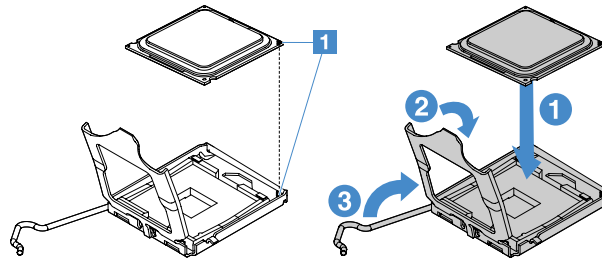

Figure 86. Microprocessor installation

Step 2. Install the heat sink on the microprocessor.

Attention: Do not touch the thermal grease on the bottom of the heat sink. Touching the thermal grease will contaminate it. If the thermal grease on the microprocessor or heat sink becomes contaminated, you must wipe off the contaminated thermal grease on the microprocessor or heat sink with the alcohol wipes and reapply clean thermal grease to the heat sink.

- a. Align the heat sink so that the arrows on the label point toward the DIMMs and place the heat sink on top of the microprocessor, thermal grease side down.
- b. Align the screws on the heat sink with the screw holes in the system board.
- c. Tighten the screws **1** with a screwdriver, alternating among the screws until they are tight. If possible, each screw should be rotated two full rotations at a time. Repeat until the screws are tight.

Attention: When the two screws that are closer to the rear of the server are tightened, the screw heads are not level with the surface of the heat sink. Do not overtighten the screws by using excessive force.

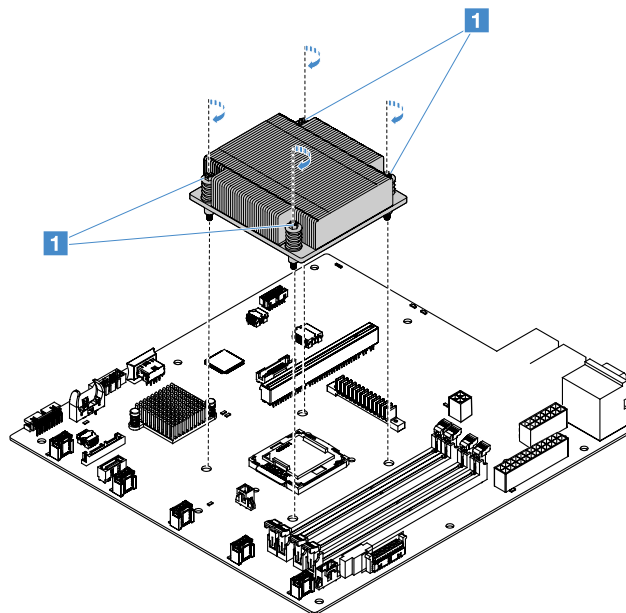

Figure 87. Heat sink installation

Step 3. Complete the parts replacement. See “Completing the parts replacement” on page 172.

Thermal grease

The thermal grease must be replaced whenever the heat sink has been removed from the top of the microprocessor. Use the following information to replace damaged or contaminated thermal grease on the microprocessor and heat sink.

Read “Handling static-sensitive devices” on page 88.

To replace damaged or contaminated thermal grease on the microprocessor and heat sink, do the following:

Step 1. Place the heat sink on a clean work surface.

Step 2. Remove the cleaning pad from its package and unfold it completely.

Step 3. Use the cleaning pad to wipe the thermal grease from the bottom of the heat sink.

Note: Make sure that all of the thermal grease is removed.

Step 4. Use a clean area of the cleaning pad to wipe the thermal grease from the microprocessor. Then, dispose of the cleaning pad after all of the thermal grease is removed.

Step 5. Use the thermal-grease syringe to place nine uniformly spaced dots **1** of 0.02 mL each on the top of the microprocessor or on the bottom of the heat sink. The outermost dots must be within approximately 5 mm of the edge of the microprocessor. This is to ensure uniform distribution of the grease.

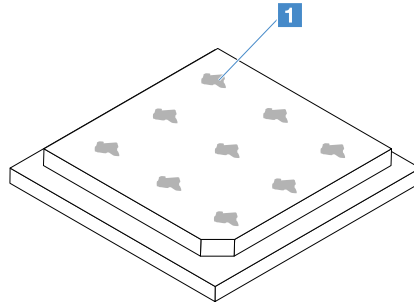

Figure 88. Thermal grease on the microprocessor

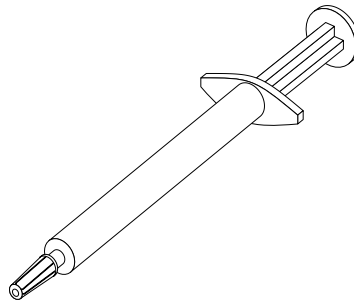

Figure 89. Thermal-grease syringe

Note: One tick mark on the syringe is 0.01 mL. If the grease is properly applied, approximately half (0.22 mL) of the grease will remain in the syringe.

Step 6. Install the heat sink onto the microprocessor. See “Installing the microprocessor and heat sink (Trained technician only)” on page 148.

Removing the power distribution board cover

To remove the power distribution board cover, do the following:

Step 1. Turn off the server. Then, disconnect all external cables and remove all peripheral devices.

Step 2. Remove the server cover. See “Removing the server cover” on page 88.

Step 3. Remove any connected SAS/SATA signal cable and all other cables that pass through the power distribution board cover. See “Internal cable routing” on page 158.

- Step 4. Remove the screw from the power distribution board cover. Then, lift the power distribution board cover up to remove it from the server.

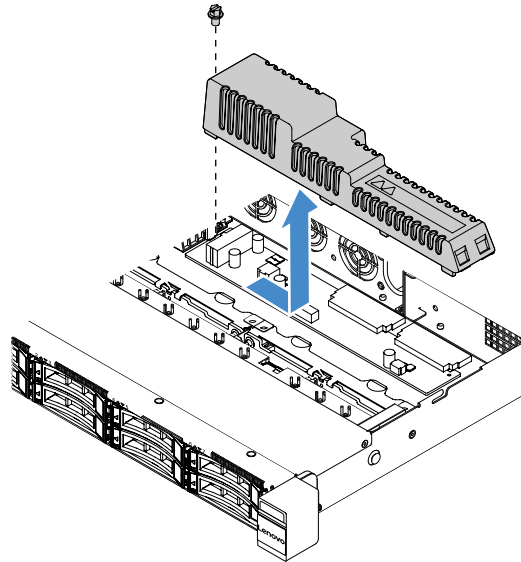

Figure 90. Power distribution board cover removal

- Step 5. Reinstall the power distribution board cover or install a new one. See “Installing the power distribution board cover” on page 152.

Installing the power distribution board cover

If you have moved the power distribution board cover, reinstall it or install a new one if the old one is broken.

To install the power distribution board cover, do the following:

- Step 1. Install the power distribution board cover.
- Align the screw hole in the power distribution board cover with the mounting stud on the chassis.
 - Lower the power distribution board cover onto the power distribution board.
 - Install the screw to secure the power distribution board cover.

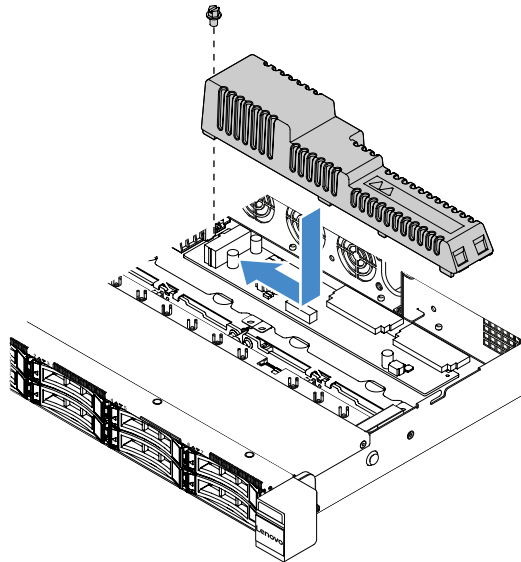

Figure 91. Power distribution board cover installation

- Step 2. Complete the parts replacement. See “Completing the parts replacement” on page 172.

Removing the power distribution board

To remove the power distribution board, do the following:

- Step 1. Turn off the server. Then, disconnect all external cables and remove all peripheral devices.
- Step 2. Remove the server cover. See “Removing the server cover” on page 88.
- Step 3. Remove the power distribution board cover. See “Removing the power distribution board cover” on page 151. Then, Loosen the cables from the cable tie.
- Step 4. Disconnect the power distribution board cables from the system board. Then, disconnect all other cables on the system board that block the removal of the power distribution board.

Step 5. Remove the screws. Then, lift the power distribution board up to remove it from the server.

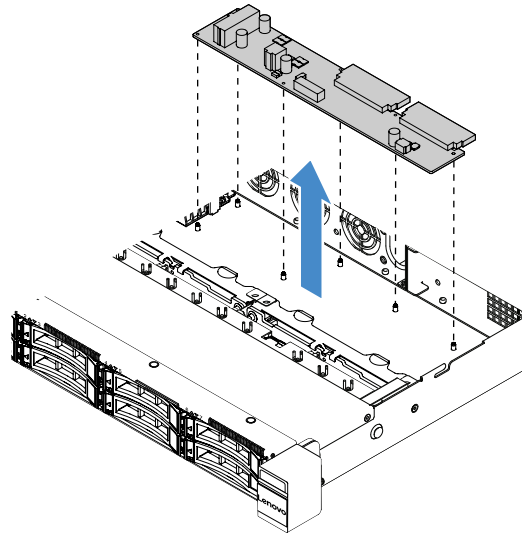

Figure 92. Power distribution board removal

Step 6. Install a new power distribution board. See “Installing the power distribution board” on page 154.

Installing the power distribution board

If you have moved the power distribution board, install a new one before turning on the server.

To install the power distribution board, do the following:

Step 1. Align the screw holes in the power distribution board with the mounting studs on the chassis and lower the power distribution board onto the chassis. Then, install the screws to secure the power distribution board.

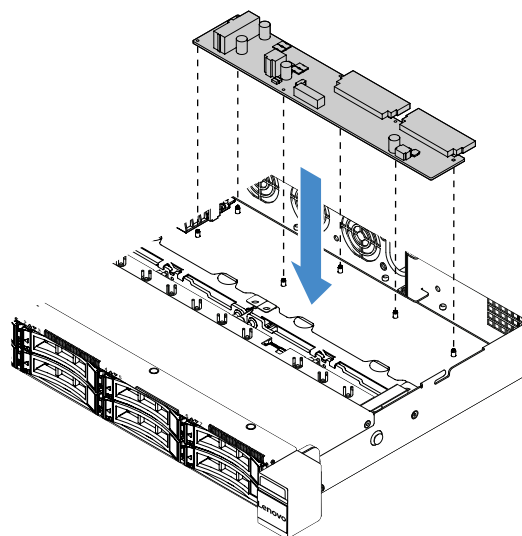

Figure 93. Power distribution board installation

- Step 2. Connect cables to the power distribution board.
- Step 3. Install the power distribution board cover. See “Installing the power distribution board cover” on page 152.
- Step 4. Connect the cables to the power supply connector, microprocessor power connector, and power distribution board connector on the system board. See “System-board connectors” on page 21.

Attention: When connecting the cable to the system board, do not grab the wires. Grab the connector to vertically connect the cable to the system board.

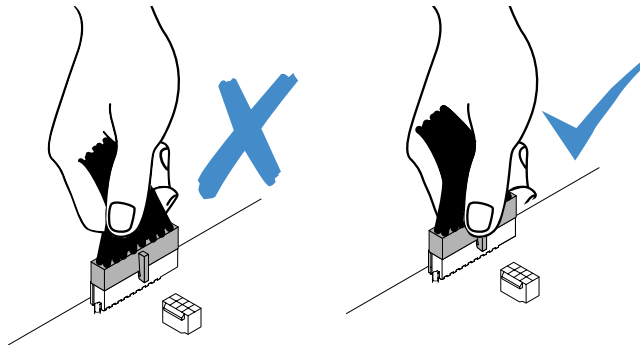

Figure 94. Connecting the power cable connector to the system board

- Step 5. Complete the parts replacement. See “Completing the parts replacement” on page 172.

Removing the system board

Before you start, notice the following information:

- After you replace the system board, you must either update the server with the latest firmware or restore the pre-existing firmware that the customer provides on a CD image. Make sure that you have the latest firmware or a copy of the pre-existing firmware before you proceed.
- When you replace the system board, make sure that you remove the Integrated Management Module II (IMM2) Advanced Upgrade and place it on the new system board. .
- Before you replace the system board, make sure that you back up any Features on Demand (FoD) keys that were enabled. Reactivate FoD after replacing the system board. To activate FoD and install activation keys automatically, refer to the instructions in the *Lenovo Features on Demand User's Guide*. To download the document, go to <http://www.ibm.com/systems/x/fod/>, log in, and click **Help**.

Note: After you remove the system board, you need to install a new one. See “Installing the system board” on page 157.

To remove the system board, do the following:

- Step 1. Turn off the server. Then, disconnect all external cables and remove all peripheral devices.
- Step 2. Remove the server cover. See “Removing the server cover” on page 88.
- Step 3. Remove the air baffle. See “Removing the air baffle” on page 90.
- Step 4. Remove the PCI riser-card assembly. See “Removing the PCI riser-card assembly” on page 93.
- Step 5. Record where the cables are connected to the system board; then, disconnect them.

Attention: Disengage all latches, cable clips, release tabs, or locks on cable connectors beforehand. See “Internal cable routing” on page 158. Failing to release them before removing

the cables will damage the cable connectors on the system board. Any damage to the cable connectors may require replacing the system board.

Step 6. Remove any of the following components that are installed on the system board and put them in a safe, static-protective place:

- Adapters (see “Removing an adapter” on page 110)
- DIMMs (see “Removing a DIMM” on page 96)
- Microprocessor and heat sink (see “Removing the microprocessor and heat sink (Trained technician only)” on page 145)

Notes:

- Do not allow the thermal grease to come in contact with anything. Contact with any surface can compromise the thermal grease and the microprocessor socket.
- Keep each heat sink paired with its microprocessor for reinstallation. A mismatch between the microprocessor and its original heat sink can require the installation of a new heat sink.
- The RAID battery holder (see “Removing the flash power module holder” on page 94)

Step 7. Remove the system board.

- a. Remove the nine screws that secure the system board to the chassis, and put the screws in a safe place.
- b. Hold the two corners **1** of the system board carefully. Avoid touching the connectors on the system board.
- c. Lift and tilt the system board upwards and slightly pull the system board towards the front of the server.
- d. Lift and remove the system board from the server carefully.

Note: When you remove the system board from the server, avoid touching the cable clips on the side of the chassis and the connectors on the system board. Do not damage any surrounding components inside the chassis.

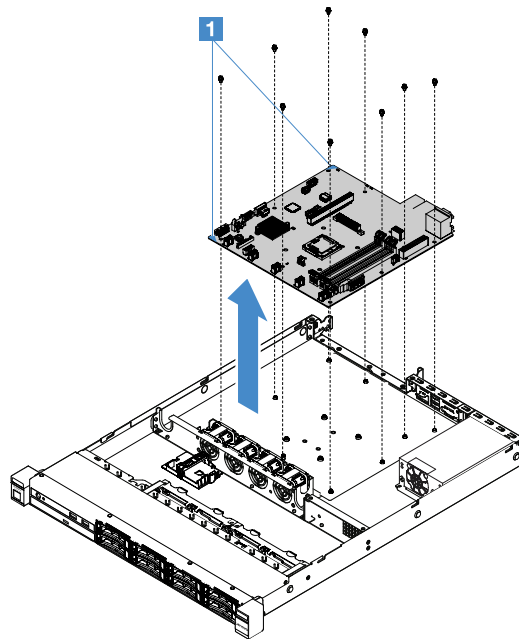

Figure 95. System board removal

If you are instructed to return the server component or optional device, follow all packaging instructions, and use any packaging materials for shipping that are supplied to you.

Before returning the failing system board, ensure that you remove the microprocessor socket cover from the new system board and install it onto the failing system board.

Installing the system board

Before you start, notice the following information:

- After you reassemble the components in the server, route all cables carefully so that they are not exposed to excessive pressure.
- When you install the system board, ensure that you remove the Integrated Management Module II (IMM2) Advanced Upgrade from the failing system board and place it on the new system board. For information about the Advanced Upgrade, see “Using the remote presence and blue-screen capture features” on page 36
- Some cluster solutions require specific code levels or coordinated code updates. If the device is part of a cluster solution, verify that the latest level of code is supported for the cluster solution before you update the code.

To install the system board, do the following:

- Step 1. Touch the static-protective package that contains the system board to any unpainted metal surface on the server; then, remove the system board from the package.

Note: When you are holding or installing the system board in the server, avoid touching the cable clips on the side of the chassis and the connectors on the system board. Do not damage any surrounding components inside the chassis.

- Step 2. Hold the two corners **1** of the system board carefully, align the screw holes in the system board with the corresponding mounting studs on the chassis, and then install the nine screws that you removed.

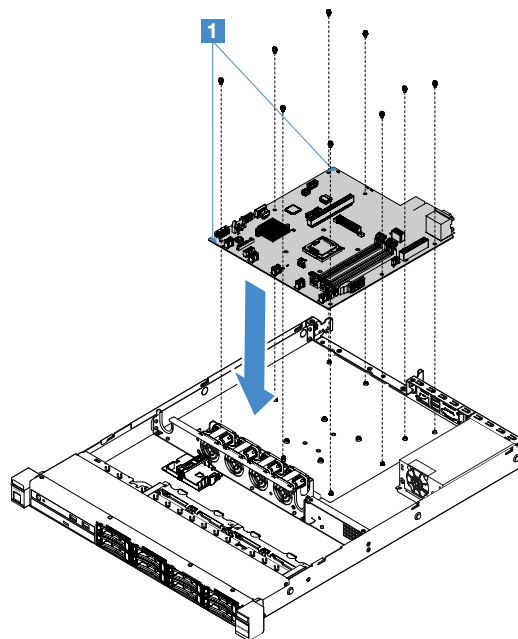

Figure 96. System board installation

Step 3. Install any of the following components that you removed from the failing system board:

Note: Make sure that none of the server cables are caught under the system board.

1. Microprocessor and heat sink (see “Installing the microprocessor and heat sink (Trained technician only)” on page 148)
2. DIMMs (see “Installing a DIMM” on page 99)
3. Adapters (see “Installing an adapter” on page 111)
4. The RAID battery holder (see “Installing flash power module holder” on page 95).

Step 4. Complete the parts replacement. See “Completing the parts replacement” on page 172.

Step 5. Remove the microprocessor socket cover from the new system board and install it onto the failing system board.

Step 6. Start the Setup Utility and reset the configuration.

- a. Set the system date and time.
- b. Set the power-on password.
- c. Reconfigure the server.

For more information, see “Using the Setup Utility program” on page 28.

Step 7. Either update the server with the latest RAID firmware or restore the pre-existing firmware from a CD image. See “Updating the firmware” on page 25.

Step 8. Update the UUID. See “Updating the Universal Unique Identifier (UUID)” on page 40.

Step 9. Update the DMI/SMBIOS. See “Updating the DMI/SMBIOS data” on page 42.

Step 10. Reactivate FoD. To activate FoD and install activation keys automatically, refer to the instructions in the *Features on Demand User's Guide*. To download the document, go to <http://www.ibm.com/systems/x/fod/>, log in, and click **Help**.

Internal cable routing

This section provides information about routing the cables when you install some components in the server.

To connect cables, observe the following instructions:

- Turn off the server before you connect or disconnect any internal cables.
- See the documentation that comes with any external devices for additional cabling instructions. It might be easier for you to route cables before you connect the devices to the server.
- Cable identifiers of some cables are printed on the cables that come with the server and optional devices. Use these identifiers to connect the cables to the correct connectors.

Optical drive cable connection

This topic provides information about the internal cable routing for the optical drive.

Notes:

- Ensure that the cable is not pinched and does not cover any connectors or obstruct any components on the system board.
- Ensure the relevant cables pass through the cable clips.

To connect the optical drive to the system board, do the following:

1. Insert one end of the optical drive cable into the slot in the connector bracket. Then slide the connector to the left as shown until it is firmly seated in the bracket.
2. Connect the other end of the optical drive cable to the system board.

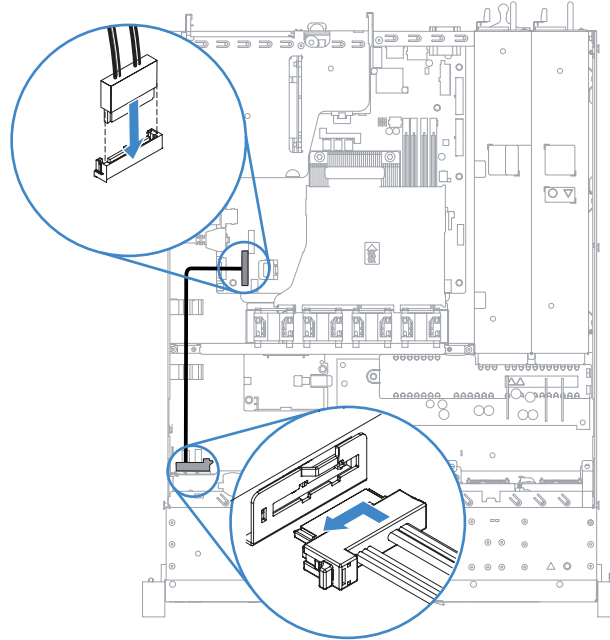

Figure 97. Optical drive cable connection

Operating temperature enhancement kit cable connection

This topic provides information about the internal cable routing for the operating temperature enhancement kit.

Notes:

- Ensure that the cable is not pinched and does not cover any connectors or obstruct any components on the system board.
- Ensure the relevant cables pass through the cable clips.

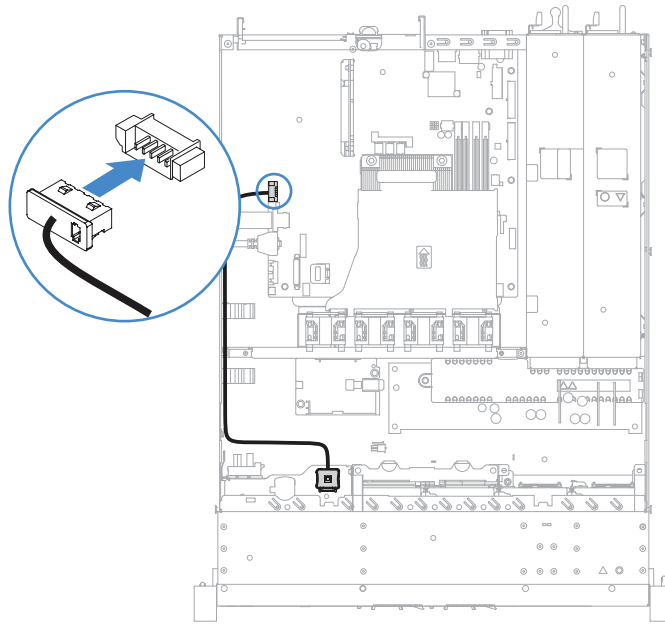

Figure 98. Operating temperature enhancement kit cable connection for the 2.5-inch hard disk drive model

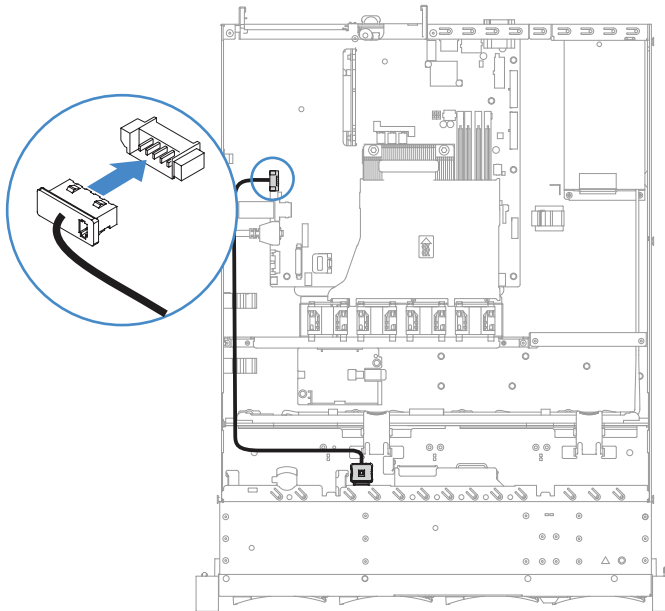

Figure 99. Operating temperature enhancement kit cable connection for the 3.5-inch hard disk drive model

Fixed power supply cable connection

This topic provides information about the cable routing for the fixed power supply.

Notes:

- Ensure that the cable is not pinched and does not cover any connectors or obstruct any components on the system board.
- Ensure the relevant cables pass through the cable clips.
- **1**: Connect to the power connector on the system board.
- **2**: Connect to the microprocessor power connector on the system board.

See “System-board connectors” on page 21.

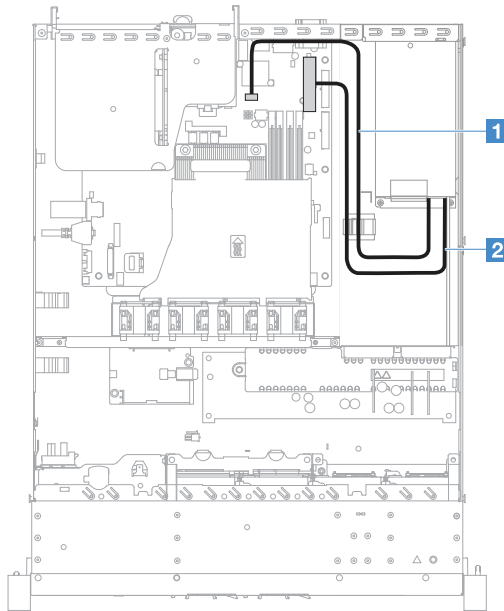

Figure 100. Fixed power supply cable connection

Front USB module and operator information panel cable connection

This topic provides information about the internal cable routing for the front USB module and the operator information panel.

Notes:

- Ensure that the cable is not pinched and does not cover any connectors or obstruct any components on the system board.
- Ensure the relevant cables pass through the cable clips.

- **1:** Press the release latch and connect to the front USB connector on the system board.
- **2:** Press evenly on the release latches and connect to the operator information panel connector on the system board.

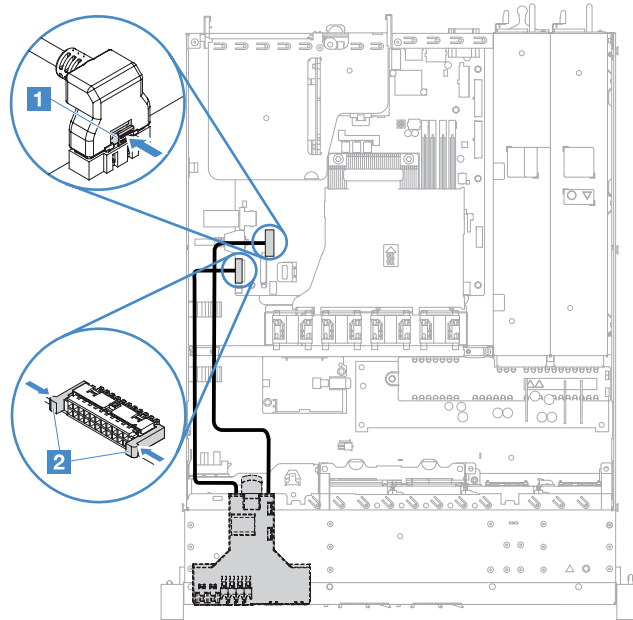

Figure 101. Operator information panel cable connection

Simple-swap HDD cable connection: onboard RAID

This topic provides information about the internal cable connection for the simple-swap hard disk drive with onboard RAID.

- **1:** Connect to the backplane power connector on the system board and the power connector on the hard-disk-drive backplate assembly.
- **2:** Connect to the Mini-SAS connector on the system board and the four connectors of the Mini-SAS cable to the hard-disk-drive backplate assembly.

Notes:

- The Mini-SAS cable has been installed to the hard-disk-drive backplate assembly by default.
- Ensure that the cable is not pinched and does not cover any connectors or obstruct any components on the system board.
- Ensure the power cable and Mini-SAS cable pass through the cable clips.

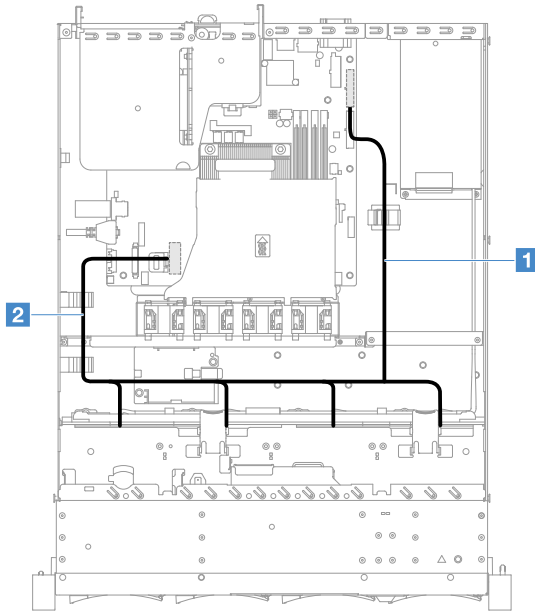

Figure 102. Simple-swap HDD cable connection: 3.5-inch, onboard RAID, and fixed power supply

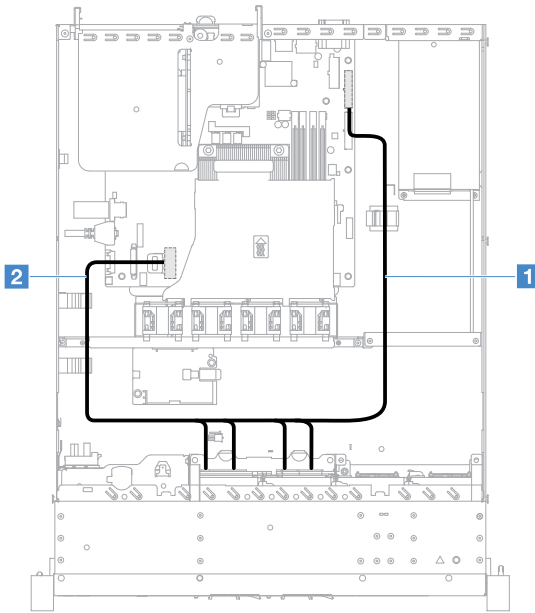

Figure 103. Simple-swap HDD cable connection: 2.5-inch, onboard RAID, and fixed power supply

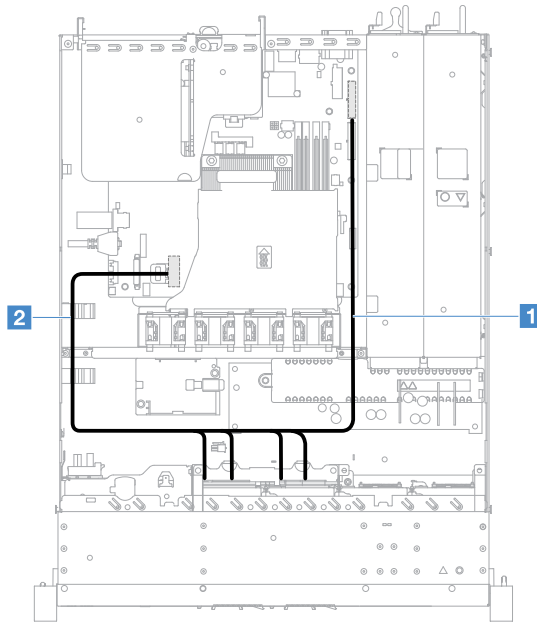

Figure 104. Simple-swap HDD cable connection: 2.5-inch, onboard RAID, and hot-swap power supply

Hot-swap HDD cable connection: ServeRAID SAS/SATA controller and fixed power supply

- **1:** Connect to the backplane power connector on the system board and the power connector on the hard-disk-drive backplane.
- **2:** Connect to the connector 0 on the ServeRAID SAS/SATA controller and the Mini-SAS connector on the hard-disk-drive backplane.

Notes:

- Ensure that the cable is not pinched and does not cover any connectors or obstruct any components on the system board.
- Ensure the relevant cables pass through the cable clips.

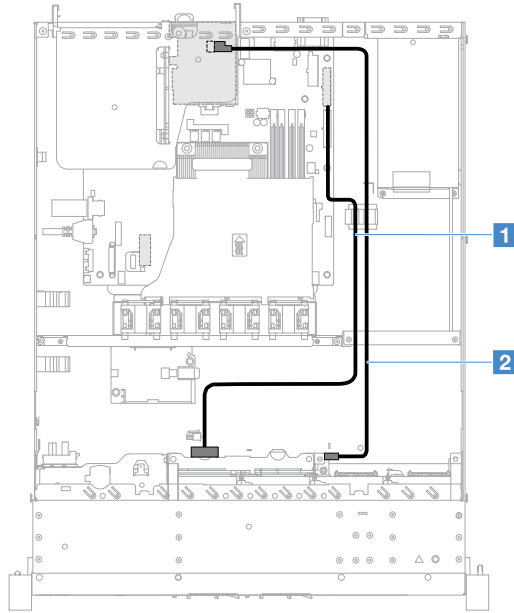

Figure 105. Hot-swap HDD cable connection: 2.5-inch, ServeRAID SAS/SATA controller installed on the right side

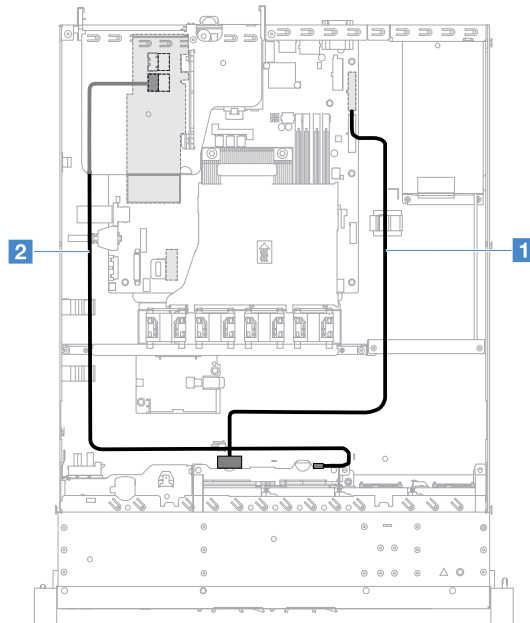

Figure 106. Hot-swap HDD cable connection: 2.5-inch, ServeRAID SAS/SATA controller installed on the left side

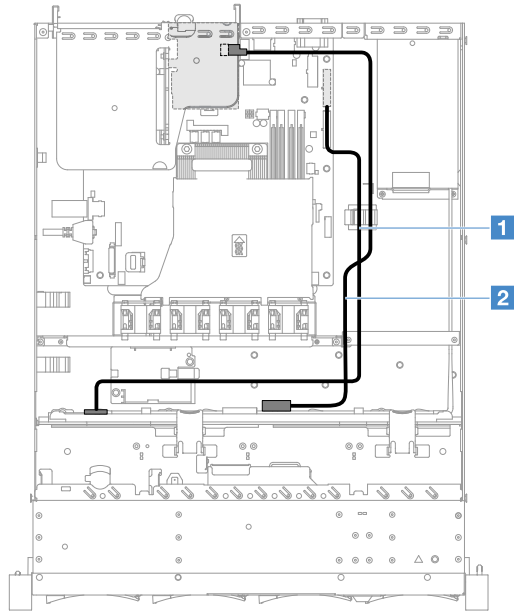

Figure 107. Hot-swap HDD cable connection: 3.5-inch, ServeRAID SAS/SATA controller installed on the right side

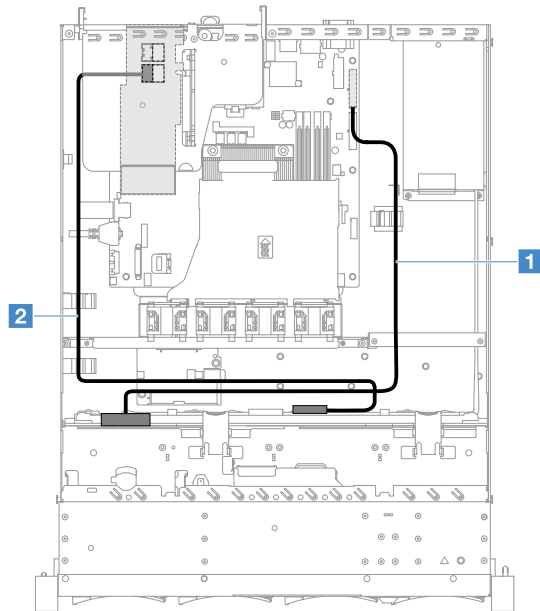

Figure 108. Hot-swap HDD cable connection: 3.5-inch, ServeRAID SAS/SATA controller installed on the left side

Simple-swap HDD cable connection: ServeRAID SAS/SATA controller and fixed power supply

- **1**: Connect to the backplane power connector on the system board and the power connector on the hard-disk-drive backplate assembly.
- **2**: Connect to the connector 0 on the ServeRAID SAS/SATA controller and the four connectors on the hard-disk-drive backplate assembly.

Notes:

- The Mini-SAS cable has been installed to the hard-disk-drive backplate assembly by default.
- Ensure that the cable is not pinched and does not cover any connectors or obstruct any components on the system board.
- Ensure the power cable and Mini-SAS cable pass through the cable clips.

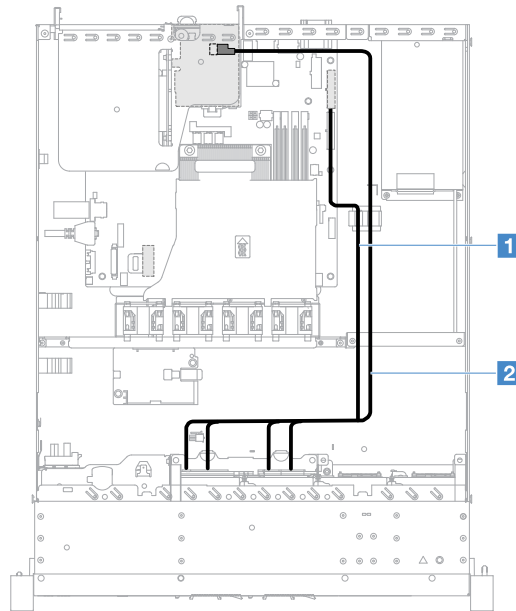

Figure 109. Simple-swap HDD cable connection: 2.5-inch, ServeRAID SAS/SATA controller installed on the right side

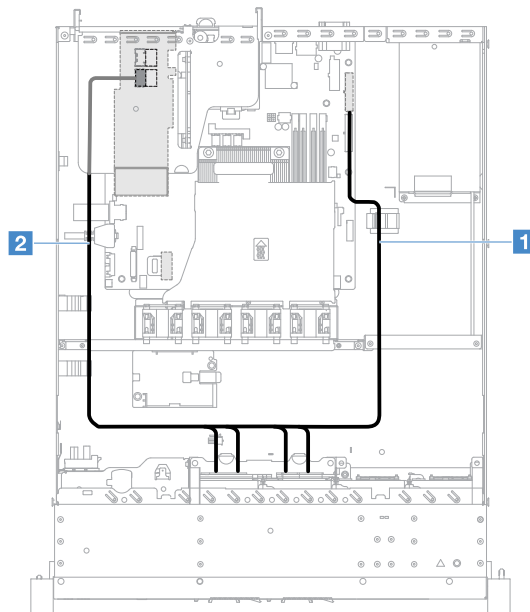

Figure 110. Simple-swap HDD cable connection: 2.5-inch, ServeRAID SAS/SATA controller installed on the left side

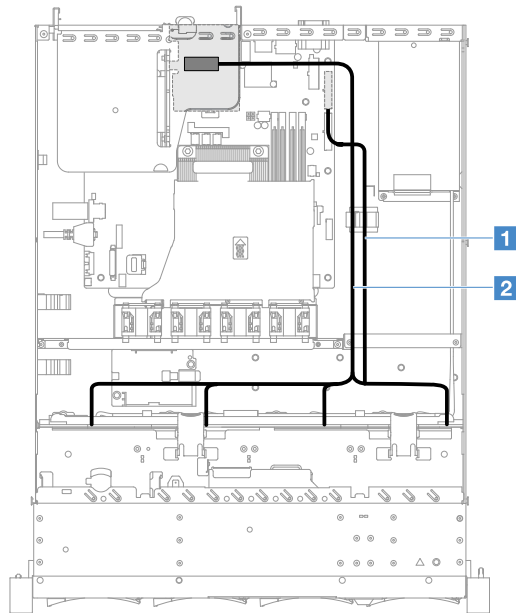

Figure 111. Simple-swap HDD cable connection: 3.5-inch, ServeRAID SAS/SATA controller installed on the right side

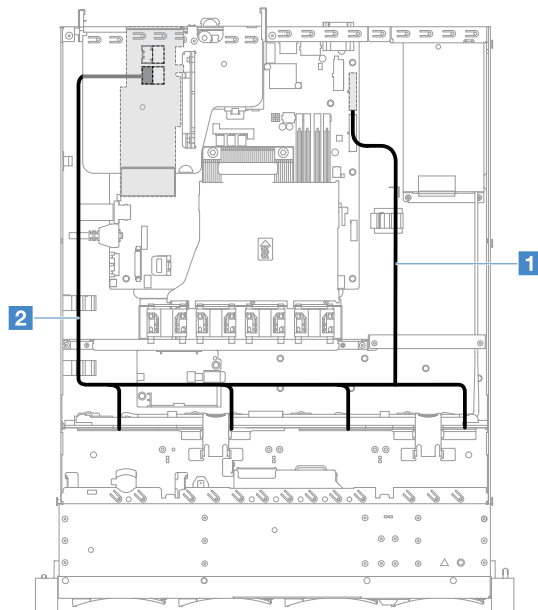

Figure 112. Simple-swap HDD cable connection: 3.5-inch, ServeRAID SAS/SATA controller installed on the left side

Hot-swap HDD cable connection: ServeRAID SAS/SATA controller and hot-swap power supply

- **1**: Connect to the backplane power connector on the system board and the power connector on the hard-disk-drive backplane.
- **2**: Connect to the connector 0 on the ServeRAID SAS/SATA controller and the Mini-SAS connector on the hard-disk-drive backplane.

Notes:

- Ensure that the cable is not pinched and does not cover any connectors or obstruct any components on the system board.
- Ensure the relevant cables pass through the cable clips.

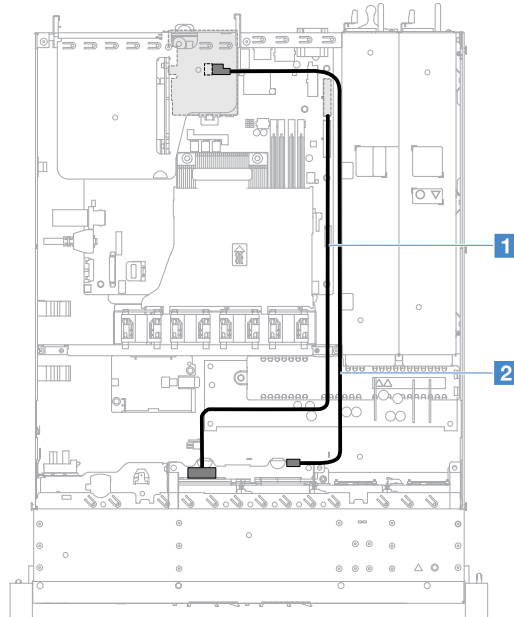

Figure 113. Hot-swap HDD cable connection: four HDDs, ServeRAID SAS/SATA controller installed on the right side

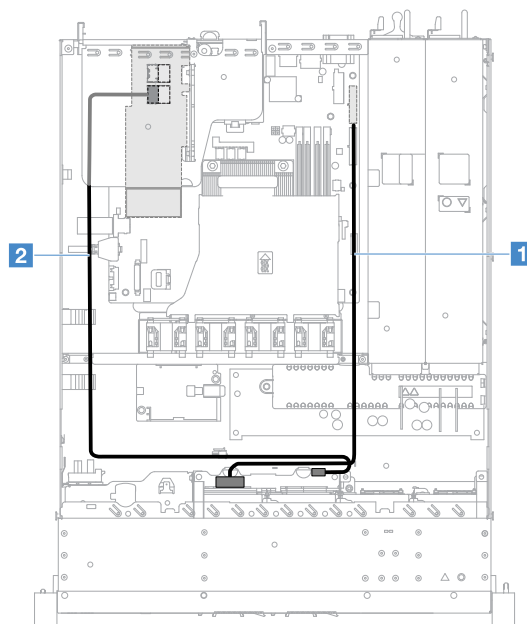

Figure 114. Hot-swap HDD cable connection: four HDDs, ServeRAID SAS/SATA controller installed on the left side

To connect cables for the server models with eight hot-swap hard disk drives, do the following:

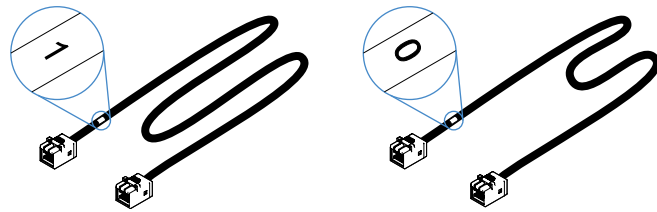

Figure 115. Cables for the 2.5-inch hard-disk-drive backplanes

1. Connect the cable labeled with 0 to the connector 0 on the ServeRAID SAS/SATA controller and the hot-swap hard-disk-drive backplane 1.
2. Connect the cable labeled with 1 to the connector 1 on the ServeRAID SAS/SATA controller and the hot-swap hard-disk-drive backplane 2.
3. Connect one connector on one end of the power cable **1** to the backplane power connector on the system board. Then, connect the two connectors on the other end of the power cable to the power connectors on the hard-disk-drive backplane 1 and 2.

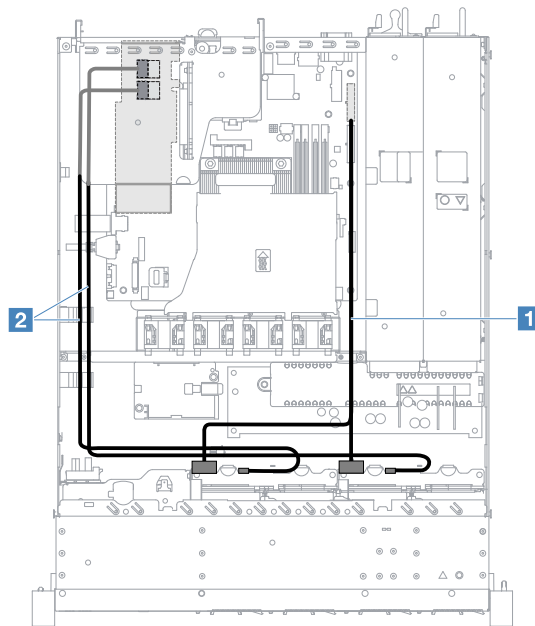

Figure 116. Hot-swap HDD cable connection: eight HDDs, ServeRAID SAS/SATA controller installed on the left side

Simple-swap HDD cable connection: ServeRAID SAS/SATA controller and redundant power supply

- **1**: Connect to the backplane power connector on the system board and the power connector on the hard-disk-drive backplate assembly.
- **2**: Connect to the connector 0 on the ServeRAID SAS/SATA controller and the four connectors on the hard-disk-drive backplate assembly.

Notes:

- The Mini-SAS cable has been installed to the hard-disk-drive backplate assembly by default.

- Ensure that the cable is not pinched and does not cover any connectors or obstruct any components on the system board.
- Ensure the power cable and Mini-SAS cable pass through the cable clips.

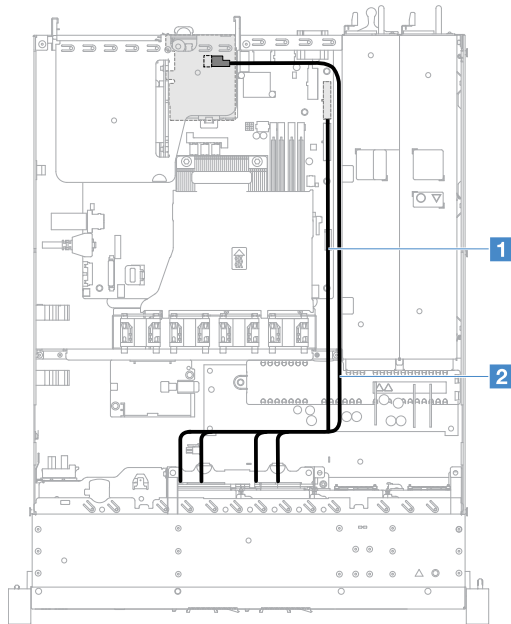

Figure 117. Simple-swap HDD cable connection: four HDDs, ServeRAID SAS/SATA controller installed on the right side

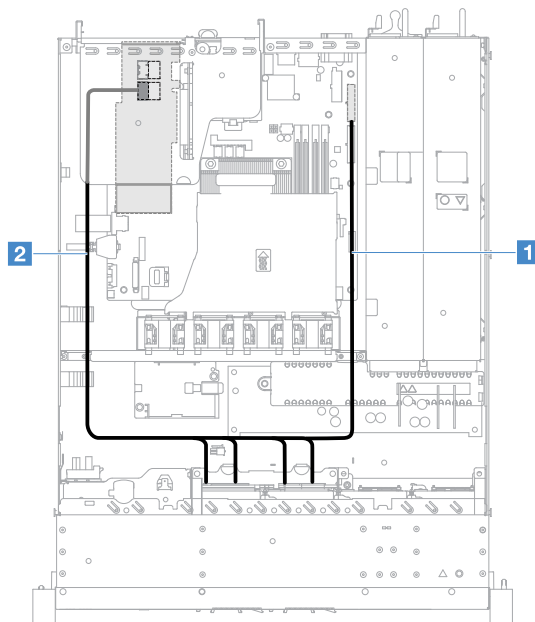

Figure 118. Simple-swap HDD cable connection: four HDDs, ServeRAID SAS/SATA controller installed on the left side

To connect cables for the server models with eight simple-swap hard disk drives, do the following:

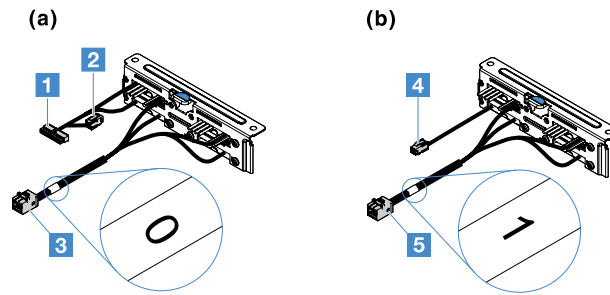

Figure 119. 2.5-inch simple-swap hard-disk-drive backplate assemblies

- **1**: Connect to the backplane power connector on the system board.
- **3**: Connect to the connector 0 on the ServeRAID SAS/SATA controller.
- **4**: Connect to the power connector **2**.
- **5**: Connect to the connector 1 on the ServeRAID SAS/SATA controller.

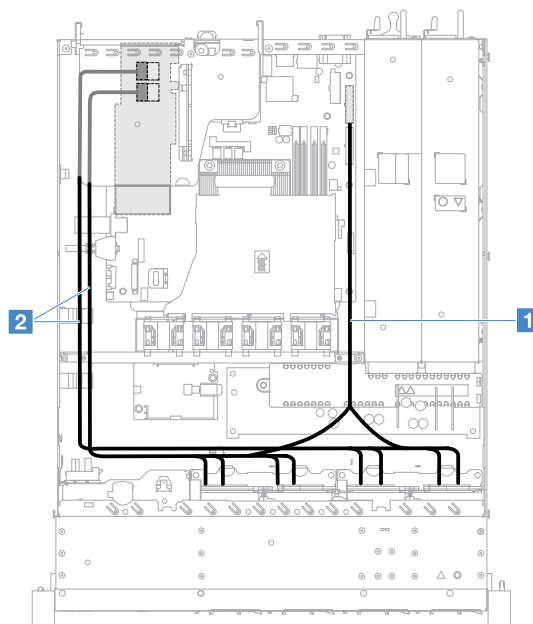

Figure 120. Simple-swap HDD cable connection: eight HDDs, ServeRAID SAS/SATA controller installed on the left side

Completing the parts replacement

To complete the parts replacement, do the following:

Note: Ensure that all components have been reassembled properly and that no tools or loose screws are left inside your server.

1. Properly route and secure the cables in the server. Refer to the cable connecting and routing information for each component. See “Internal cable routing” on page 158.
2. If you removed the server cover, reinstall it. See “Installing the server cover” on page 89.
3. Install the server into the rack. See the *Rack Installation Instructions* that comes with the server.

4. Reconnect the power cords.
5. Update the server configuration.
 - a. Save the new configuration settings when starting the server for the first time after you add or remove a device. The Setup Utility program starts automatically.
 - b. Install device drivers for some optional devices. See the documentation that comes with each device
 - c. Reconfigure the disk arrays if you have installed or removed an HDD and a RAID adapter. See the documentation that comes with the RAID adapter
 - d. Configure the Ethernet controller, see “Ethernet controller information” on page 38.
6. Start the server. Confirm that it starts properly and recognizes the newly installed devices, and make sure that no error LEDs are lit.
7. For Business Partners only: Complete the additional steps in “Instructions for Business Partners” on page 173.

Instructions for Business Partners

This topic provides instructions for Business Partners on verifying the newly installed devices by running the Dynamic System Analysis (DSA) stress test.

In addition to the instructions in this chapter for installing optional hardware devices, updating firmware and device drivers, and completing the installation, Business Partners must also do the following:

1. After you have confirmed that the server starts correctly and recognizes the newly installed devices and that no error LEDs are lit, run the DSA stress test. For information about using DSA, see “Dynamic System Analysis” on page 58.
2. Shut down and restart the server multiple times to ensure that the server is correctly configured and functions properly with the newly installed devices.
3. Save the DSA log as a file and send it to Lenovo. See “Sending DSA data to Lenovo” on page 173.
4. To ship the server, repackage it in the original undamaged packing material and observe Lenovo procedures for shipping.

Support information for Business Partners is available at <http://www.ibm.com/partnerworld>.

Sending DSA data to Lenovo

Before you send DSA data to Lenovo, read the terms of use at:
<http://www.ibm.com/de/support/ecurep/terms.html>

You can use any of the following methods to send the DSA data to Lenovo:

- **Standard upload:**
http://www.ibm.com/de/support/ecurep/send_http.html
- **Standard upload with the system serial number:**
http://www.ecurep.ibm.com/app/upload_hw
- **Secure upload:**
http://www.ibm.com/de/support/ecurep/send_http.html#secure
- **Secure upload with the system serial number:**
https://www.ecurep.ibm.com/app/upload_hw

Returning a device or component

If you are instructed to return a device or component, follow all packaging instructions, and use any packaging materials that are supplied to you for shipping.

Appendix A. Integrated Management Module II (IMM2) error messages

This section details the Integrated Management Module II (IMM2) error messages.

When a hardware event is detected by the IMM2 on the server, the IMM2 logs that event in the system-event log in the server.

For each event code, the following fields are displayed:

Event identifier

A hexadecimal identifier that uniquely identifies an event or class of events. In this documentation, the event identifiers are prefixed with 0x and followed by eight characters.

Event description

The logged message string that appears for an event. When the event string is displayed in the event log, information such as a specific component is displayed. In this documentation, that additional information appears as variables, such as [arg1] or [arg2].

Explanation

Provides additional information to explain why the event occurred.

Severity

An indication of the level of concern for the condition. In the system-event log, severity is abbreviated to the first character. The following severities can be displayed.

Info:

The event was recorded for audit purposes, usually a user action or a change of states that is normal behavior.

Warning:

The event is not as severe as an error, but if possible, the condition should be corrected before it becomes an error. It might also be a condition that requires additional monitoring or maintenance.

Error:

The event is a failure or critical condition that impairs service or an expected function.

Alert Category

Similar events are grouped together in categories. The alert category is in the following format:

severity - device

severity is one of the following severity levels:

- **Critical:** A key component in the server is no longer functioning.
- **Warning:** The event might progress to a critical level.
- **System:** The event is the result of a system error or a configuration change.

device is the specific device in the server that caused the event to be generated.

Serviceable

Specifies whether user action is required to correct the problem.

CIM Information

Provides the prefix of the message ID and the sequence number that is used by the CIM message registry.

SNMP Trap ID

The SNMP trap ID that is found in the SNMP alert management information base (MIB).

Automatically contact Service

If this field is set to **Yes**, and you have enabled Electronic Service Agent (ESA), IBM Support will be notified automatically if the event is generated.

While you wait for IBM Support to call, you can perform the recommended actions for the event.

User response

Indicates what actions you should perform to solve the event.

Perform the steps listed in this section in the order shown until the problem is solved. After you perform all of the actions that are described in this field, if you cannot solve the problem, contact IBM Support.

Note: This list includes error codes and messages that might not apply to this machine type and model.

The following is the list of IMM2 error messages and suggested actions to correct the detected server problems. For more information about IMM2, see the *Integrated Management Module II User's Guide* at http://publib.boulder.ibm.com/infocenter/systemx/documentation/topic/com.lenovo.sysx.imm2.doc/product_page.html.

List of IMM events

This section lists all messages that can be sent from the IMM.

- **40000001-00000000 : Management Controller [arg1] Network Initialization Complete.**

This message is for the use case where a Management Controller network has completed initialization.

May also be shown as 4000000100000000 or 0x4000000100000000

Severity

Info

Serviceable

No

Automatically notify support

No

Alert Category

System - IMM Network event

SNMP Trap ID

37

CIM Information

Prefix: IMM ID: 0001

User Response

Information only; no action is required.

- **40000002-00000000 : Certificate Authority [arg1] has detected a [arg2] Certificate Error.**

This message is for the use case when there is an error with an SSL Server, SSL Client, or SSL Trusted CA Certificate.

May also be shown as 4000000200000000 or 0x4000000200000000

Severity

Error

Serviceable

No

Automatically notify support

No

Alert Category

System - SSL certification

SNMP Trap ID

22

CIM Information

Prefix: IMM ID: 0002

User Response

Make sure that the certificate that you are importing is correct and properly generated.

- **40000003-00000000 : Ethernet Data Rate modified from [arg1] to [arg2] by user [arg3].**

This message is for the use case where a user modifies the Ethernet Port data rate.

May also be shown as 4000000300000000 or 0x4000000300000000

Severity

Info

Serviceable

No

Automatically notify support

No

Alert Category

none

SNMP Trap ID

CIM Information

Prefix: IMM ID: 0003

User Response

Information only; no action is required.

- **40000004-00000000 : Ethernet Duplex setting modified from [arg1] to [arg2] by user [arg3].**

This message is for the use case where A user modifies the Ethernet Port duplex setting.

May also be shown as 4000000400000000 or 0x4000000400000000

Severity

Info

Serviceable

No

Automatically notify support

No

Alert Category

none

SNMP Trap ID

CIM Information

Prefix: IMM ID: 0004

User Response

Information only; no action is required.

- **40000005-00000000 : Ethernet MTU setting modified from [arg1] to [arg2] by user [arg3].**

This message is for the use case where a user modifies the Ethernet Port MTU setting.

May also be shown as 4000000500000000 or 0x4000000500000000

Severity

Info

Serviceable

No

Automatically notify support

No

Alert Category

none

SNMP Trap ID

CIM Information

Prefix: IMM ID: 0005

User Response

Information only; no action is required.

- **40000006-00000000 : Ethernet locally administered MAC address modified from [arg1] to [arg2] by user [arg3].**

This message is for the use case where a user modifies the Ethernet Port MAC address setting.

May also be shown as 4000000600000000 or 0x4000000600000000

Severity

Info

Serviceable

No

Automatically notify support

No

Alert Category

none

SNMP Trap ID

CIM Information

Prefix: IMM ID: 0006

User Response

Information only; no action is required.

- **40000007-00000000 : Ethernet interface [arg1] by user [arg2].**

This message is for the use case where a user enables or disabled the ethernet interface.

May also be shown as 4000000700000000 or 0x4000000700000000

Severity

Info

Serviceable

No

Automatically notify support

No

Alert Category

none

SNMP Trap ID

CIM Information

Prefix: IMM ID: 0007

User Response

Information only; no action is required.

- **40000008-00000000 : Hostname set to [arg1] by user [arg2].**

This message is for the use case where user modifies the Hostname of a Management Controller.

May also be shown as 4000000800000000 or 0x4000000800000000

Severity

Info

Serviceable

No

Automatically notify support

No

Alert Category

System - IMM Network event

SNMP Trap ID

37

CIM Information

Prefix: IMM ID: 0008

User Response

Information only; no action is required.

- **40000009-00000000 : IP address of network interface modified from [arg1] to [arg2] by user [arg3].**

This message is for the use case where user modifies the IP address of a Management Controller.

May also be shown as 4000000900000000 or 0x4000000900000000

Severity

Info

Serviceable

No

Automatically notify support

No

Alert Category

System - IMM Network event

SNMP Trap ID

37

CIM Information

Prefix: IMM ID: 0009

User Response

Information only; no action is required.

- **4000000a-00000000 : IP subnet mask of network interface modified from [arg1] to [arg2] by user [arg3].**

This message is for the use case where a user modifies the IP subnet mask of a Management Controller.

May also be shown as 4000000a00000000 or 0x4000000a00000000

Severity

Info

Serviceable

No

Automatically notify support

No

Alert Category

none

SNMP Trap ID**CIM Information****Prefix: IMM ID:** 0010**User Response**

Information only; no action is required.

- **4000000b-00000000 : IP address of default gateway modified from [arg1] to [arg2] by user [arg3].**

This message is for the use case where a user modifies the default gateway IP address of a Management Controller.

May also be shown as 4000000b00000000 or 0x4000000b00000000

Severity

Info

Serviceable

No

Automatically notify support

No

Alert Category

none

SNMP Trap ID**CIM Information****Prefix: IMM ID:** 0011**User Response**

Information only; no action is required.

- **4000000c-00000000 : OS Watchdog response [arg1] by [arg2].**

This message is for the use case where an OS Watchdog has been enabled or disabled by a user.

May also be shown as 4000000c00000000 or 0x4000000c00000000

Severity

Warning

Serviceable

No

Automatically notify support

No

Alert Category

none

SNMP Trap ID**CIM Information**

Prefix: IMM ID: 0012

User Response

Information only; no action is required.

- **4000000d-00000000 : DHCP[[arg1]] failure, no IP address assigned.**

This message is for the use case where a DHCP server fails to assign an IP address to a Management Controller.

May also be shown as 4000000d00000000 or 0x4000000d00000000

Severity

Warning

Serviceable

No

Automatically notify support

No

Alert Category

none

SNMP Trap ID**CIM Information**

Prefix: IMM ID: 0013

User Response

Complete the following steps until the problem is solved:

1. Make sure that the IMM network cable is connected.
2. Make sure that there is a DHCP server on the network that can assign an IP address to the IMM.

- **4000000e-00000000 : Remote Login Successful. Login ID: [arg1] from [arg2] at IP address [arg3].**

This message is for the use case where a user successfully logs in to a Management Controller.

May also be shown as 4000000e00000000 or 0x4000000e00000000

Severity

Info

Serviceable

No

Automatically notify support

No

Alert Category

System - Remote Login

SNMP Trap ID

30

CIM Information

Prefix: IMM ID: 0014

User Response

Information only; no action is required.

- **4000000f-00000000 : Attempting to [arg1] server [arg2] by user [arg3].**

This message is for the use case where a user is using the Management Controller to perform a power function on the system.

May also be shown as 4000000f00000000 or 0x4000000f00000000

Severity

Info

Serviceable

No

Automatically notify support

No

Alert Category

none

SNMP Trap ID

CIM Information

Prefix: IMM ID: 0015

User Response

Information only; no action is required.

- **40000010-00000000 : Security: Userid: [arg1] had [arg2] login failures from WEB client at IP address [arg3].**

This message is for the use case where a user has failed to log in to a Management Controller from a web browser.

May also be shown as 4000001000000000 or 0x4000001000000000

Severity

Warning

Serviceable

No

Automatically notify support

No

Alert Category

System - Remote Login

SNMP Trap ID

30

CIM Information

Prefix: IMM ID: 0016

User Response

Complete the following steps until the problem is solved:

1. Make sure that the correct login ID and password are being used.
2. Have the system administrator reset the login ID or password.

- **40000011-00000000 : Security: Login ID: [arg1] had [arg2] login failures from CLI at [arg3].**

This message is for the use case where a user has failed to log in to a Management Controller from the Legacy CLI.

May also be shown as 4000001100000000 or 0x4000001100000000

Severity

Warning

Serviceable

No

Automatically notify support

No

Alert Category

System - Remote Login

SNMP Trap ID

30

CIM Information

Prefix: IMM ID: 0017

User Response

Complete the following steps until the problem is solved:

1. Make sure that the correct login ID and password are being used.
2. Have the system administrator reset the login ID or password.

- **40000012-00000000 : Remote access attempt failed. Invalid userid or password received. Userid is [arg1] from WEB browser at IP address [arg2].**

This message is for the use case where a remote user has failed to establish a remote control session from a Web browser session.

May also be shown as 4000001200000000 or 0x4000001200000000

Severity

Info

Serviceable

No

Automatically notify support

No

Alert Category

System - Remote Login

SNMP Trap ID

30

CIM Information

Prefix: IMM ID: 0018

User Response

Make sure that the correct login ID and password are being used.

- **40000013-00000000 : Remote access attempt failed. Invalid userid or password received. Userid is [arg1] from TELNET client at IP address [arg2].**

This message is for the use case where a user has failed to log in to a Management Controller from a telnet session.

May also be shown as 4000001300000000 or 0x4000001300000000

Severity

Info

Serviceable

No

Automatically notify support

No

Alert Category

System - Remote Login

SNMP Trap ID

30

CIM Information

Prefix: IMM ID: 0019

User Response

Make sure that the correct login ID and password are being used.

- **40000014-00000000 : The [arg1] on system [arg2] cleared by user [arg3].**

This message is for the use case where a Management Controller Event Log on a system is cleared by a user.

May also be shown as 4000001400000000 or 0x4000001400000000

Severity

Info

Serviceable

No

Automatically notify support

No

Alert Category

none

SNMP Trap ID**CIM Information**

Prefix: IMM ID: 0020

User Response

Information only; no action is required.

- **40000015-00000000 : Management Controller [arg1] reset was initiated by user [arg2].**

This message is for the use case where a Management Controller reset is initiated by a user.

May also be shown as 4000001500000000 or 0x4000001500000000

Severity

Info

Serviceable

No

Automatically notify support

No

Alert Category

none

SNMP Trap ID**CIM Information**

Prefix: IMM ID: 0021

User Response

Information only; no action is required.

- **40000016-00000000 : ENET[[arg1]] DHCP-HSTN=[arg2], DN=[arg3], IP@=[arg4], SN=[arg5], GW@=[arg6], DNS1@=[arg7].**

This message is for the use case where a Management Controller IP address and configuration has been assigned by the DHCP server.

May also be shown as 4000001600000000 or 0x4000001600000000

Severity

Info

Serviceable

No

Automatically notify support

No

Alert Category

none

SNMP Trap ID**CIM Information**

Prefix: IMM ID: 0022

User Response

Information only; no action is required.

- **40000017-00000000 : ENET[[arg1]] IP-Cfg:HstName=[arg2], IP@[arg3] ,NetMsk=[arg4], GW@[arg5].**

This message is for the use case where a Management Controller IP address and configuration has been assigned statically using user data.

May also be shown as 4000001700000000 or 0x4000001700000000

Severity

Info

Serviceable

No

Automatically notify support

No

Alert Category

none

SNMP Trap ID**CIM Information**

Prefix: IMM ID: 0023

User Response

Information only; no action is required.

- **40000018-00000000 : LAN: Ethernet[[arg1]] interface is no longer active.**

This message is for the use case where a Management Controller ethernet interface is no longer active.

May also be shown as 4000001800000000 or 0x4000001800000000

Severity

Info

Serviceable

No

Automatically notify support

No

Alert Category

none

SNMP Trap ID

CIM Information

Prefix: IMM ID: 0024

User Response

Information only; no action is required.

- **40000019-00000000 : LAN: Ethernet[[arg1]] interface is now active.**

This message is for the use case where a Management Controller ethernet interface is now active.

May also be shown as 4000001900000000 or 0x4000001900000000

Severity

Info

Serviceable

No

Automatically notify support

No

Alert Category

none

SNMP Trap ID

CIM Information

Prefix: IMM ID: 0025

User Response

Information only; no action is required.

- **4000001a-00000000 : DHCP setting changed to [arg1] by user [arg2].**

This message is for the use case where a user changes the DHCP setting.

May also be shown as 4000001a00000000 or 0x4000001a00000000

Severity

Info

Serviceable

No

Automatically notify support

No

Alert Category

none

SNMP Trap ID

CIM Information

Prefix: IMM ID: 0026

User Response

Information only; no action is required.

- **4000001b-00000000 : Management Controller [arg1]: Configuration restored from a file by user [arg2].**

This message is for the use case where a user restores a Management Controller configuration from a file.

May also be shown as 4000001b00000000 or 0x4000001b00000000

Severity

Info

Serviceable

No

Automatically notify support

No

Alert Category

none

SNMP Trap ID

CIM Information

Prefix: IMM ID: 0027

User Response

Information only; no action is required.

- **4000001c-00000000 : Watchdog [arg1] Screen Capture Occurred.**

This message is for the use case where an operating system error has occurred and the screen was captured.

May also be shown as 4000001c00000000 or 0x4000001c00000000

Severity

Info

Serviceable

No

Automatically notify support

No

Alert Category

System - other

SNMP Trap ID

22

CIM Information

Prefix: IMM ID: 0028

User Response

If there was no operating-system error, complete the following steps until the problem is solved:

1. Reconfigure the watchdog timer to a higher value.
2. Make sure that the IMM Ethernet-over-USB interface is enabled.
3. Reinstall the RNDIS or cdc_ether device driver for the operating system.
4. Disable the watchdog.

If there was an operating-system error, check the integrity of the installed operating system.

- **4000001d-00000000 : Watchdog [arg1] Failed to Capture Screen.**

This message is for the use case where an operating system error has occurred and the screen capture failed.

May also be shown as 4000001d00000000 or 0x4000001d00000000

Severity

Error

Serviceable

No

Automatically notify support

No

Alert Category

System - other

SNMP Trap ID

22

CIM Information

Prefix: IMM ID: 0029

User Response

Complete the following steps until the problem is solved:

1. Reconfigure the watchdog timer to a higher value.
2. Make sure that the IMM Ethernet over USB interface is enabled.
3. Reinstall the RNDIS or cdc_ether device driver for the operating system.
4. Disable the watchdog. Check the integrity of the installed operating system.
5. Update the IMM firmware. Important: Some cluster solutions require specific code levels or coordinated code updates. If the device is part of a cluster solution, verify that the latest level of code is supported for the cluster solution before you update the code.

- **4000001e-00000000 : Running the backup Management Controller [arg1] main application.**

This message is for the use case where a Management Controller has resorted to running the backup main application.

May also be shown as 4000001e00000000 or 0x4000001e00000000

Severity

Warning

Serviceable

No

Automatically notify support

No

Alert Category

System - other

SNMP Trap ID

22

CIM Information

Prefix: IMM ID: 0030

User Response

Update the IMM firmware. Important: Some cluster solutions require specific code levels or coordinated code updates. If the device is part of a cluster solution, verify that the latest level of code is supported for the cluster solution before you update the code.

- **4000001f-00000000 : Please ensure that the Management Controller [arg1] is flashed with the correct firmware. The Management Controller is unable to match its firmware to the server.**

This message is for the use case where a Management Controller firmware version does not match the server.

May also be shown as 4000001f00000000 or 0x4000001f00000000

Severity

Error

Serviceable

No

Automatically notify support

No

Alert Category

System - other

SNMP Trap ID

22

CIM Information

Prefix: IMM ID: 0031

User Response

Update the IMM firmware to a version that the server supports. Important: Some cluster solutions require specific code levels or coordinated code updates. If the device is part of a cluster solution, verify that the latest level of code is supported for the cluster solution before you update the code.

- **40000020-00000000 : Management Controller [arg1] Reset was caused by restoring default values.**

This message is for the use case where a Management Controller has been reset due to a user restoring the configuration to default values.

May also be shown as 4000002000000000 or 0x4000002000000000

Severity

Info

Serviceable

No

Automatically notify support

No

Alert Category

none

SNMP Trap ID

CIM Information

Prefix: IMM ID: 0032

User Response

Information only; no action is required.

- **40000021-00000000 : Management Controller [arg1] clock has been set from NTP server [arg2].**

This message is for the use case where a Management Controller clock has been set from the Network Time Protocol server.

May also be shown as 4000002100000000 or 0x4000002100000000

Severity

Info

Serviceable

No

Automatically notify support

No

Alert Category

none

SNMP Trap ID

CIM Information

Prefix: IMM ID: 0033

User Response

Information only; no action is required.

- **40000022-00000000 : SSL data in the Management Controller [arg1] configuration data is invalid. Clearing configuration data region and disabling SSL.**

This message is for the use case where a Management Controller has detected invalid SSL data in the configuration data and is clearing the configuration data region and disabling the SSL.

May also be shown as 4000002200000000 or 0x4000002200000000

Severity

Error

Serviceable

No

Automatically notify support

No

Alert Category

System - other

SNMP Trap ID

22

CIM Information

Prefix: IMM ID: 0034

User Response

Complete the following steps until the problem is solved:

1. Make sure that the certificate that you are importing is correct.
2. Try to import the certificate again.

- **40000023-00000000 : Flash of [arg1] from [arg2] succeeded for user [arg3].**

This message is for the use case where a user has successfully flashed the firmware component (MC Main Application, MC Boot ROM, BIOS, Diagnostics, System Power Backplane, Remote Expansion Enclosure Power Backplane, Integrated System Management Processor, or Remote Expansion Enclosure Processor) from the interface and IP address (%d.

May also be shown as 4000002300000000 or 0x4000002300000000

Severity

Info

Serviceable

No

Automatically notify support

No

Alert Category

none

SNMP Trap ID

CIM Information

Prefix: IMM ID: 0035

User Response

Information only; no action is required.

- **40000024-00000000 : Flash of [arg1] from [arg2] failed for user [arg3].**

This message is for the use case where a user has not flashed the firmware component from the interface and IP address due to a failure.

May also be shown as 4000002400000000 or 0x4000002400000000

Severity

Info

Serviceable

No

Automatically notify support

No

Alert Category

System - other

SNMP Trap ID

22

CIM Information

Prefix: IMM ID: 0036

User Response

Information only; no action is required.

- **40000025-00000000 : The [arg1] on system [arg2] is 75% full.**

This message is for the use case where a Management Controller Event Log on a system is 75% full.

May also be shown as 4000002500000000 or 0x4000002500000000

Severity

Info

Serviceable

No

Automatically notify support

No

Alert Category

System - Event Log 75% full

SNMP Trap ID

35

CIM Information

Prefix: IMM ID: 0037

User Response

Information only; no action is required.

- **40000026-00000000 : The [arg1] on system [arg2] is 100% full.**

This message is for the use case where a Management Controller Event Log on a system is 100% full.

May also be shown as 4000002600000000 or 0x4000002600000000

Severity

Info

Serviceable

No

Automatically notify support

No

Alert Category

System - Event Log Fullness

SNMP Trap ID

35

CIM Information

Prefix: IMM ID: 0038

User Response

To avoid losing older log entries, save the log as a text file and clear the log.

- **40000027-00000000 : Platform Watchdog Timer expired for [arg1].**

This message is for the use case when an implementation has detected a Platform Watchdog Timer Expired

May also be shown as 4000002700000000 or 0x4000002700000000

Severity

Error

Serviceable

No

Automatically notify support

No

Alert Category

System - OS Timeout

SNMP Trap ID

21

CIM Information

Prefix: IMM ID: 0039

User Response

Complete the following steps until the problem is solved:

1. Reconfigure the watchdog timer to a higher value.
2. Make sure that the IMM Ethernet-over-USB interface is enabled.
3. Reinstall the RNDIS or cdc_ether device driver for the operating system.
4. Disable the watchdog.
5. Check the integrity of the installed operating system.

- **40000028-00000000 : Management Controller Test Alert Generated by [arg1].**

This message is for the use case where a user has generated a Test Alert.

May also be shown as 4000002800000000 or 0x4000002800000000

Severity

Info

Serviceable

No

Automatically notify support

No

Alert Category

System - other

SNMP Trap ID

22

CIM Information

Prefix: IMM ID: 0040

User Response

Information only; no action is required.

- **40000029-00000000 : Security: Userid: [arg1] had [arg2] login failures from an SSH client at IP address [arg3].**

This message is for the use case where a user has failed to log in to a Management Controller from SSH.

May also be shown as 4000002900000000 or 0x4000002900000000

Severity

Info

Serviceable

No

Automatically notify support

No

Alert Category

System - Remote Login

SNMP Trap ID

30

CIM Information**Prefix: IMM ID: 0041****User Response**

Complete the following steps until the problem is solved:

1. Make sure that the correct login ID and password are being used.
2. Have the system administrator reset the login ID or password.

- **4000002a-00000000 : [arg1] firmware mismatch internal to system [arg2]. Please attempt to flash the [arg3] firmware.**

This message is for the use case where a specific type of firmware mismatch has been detected.

May also be shown as 4000002a00000000 or 0x4000002a00000000

Severity

Error

Serviceable

No

Automatically notify support

No

Alert Category

System - Other

SNMP Trap ID

22

CIM Information**Prefix: IMM ID: 0042****User Response**

Reflash the IMM firmware to the latest version.

- **4000002b-00000000 : Domain name set to [arg1].**

Domain name set by user

May also be shown as 4000002b00000000 or 0x4000002b00000000

Severity

Info

Serviceable

No

Automatically notify support

No

Alert Category

none

SNMP Trap ID

CIM Information

Prefix: IMM ID: 0043

User Response

Information only; no action is required.

- **4000002c-00000000 : Domain Source changed to [arg1] by user [arg2].**

Domain source changed by user

May also be shown as 4000002c00000000 or 0x4000002c00000000

Severity

Info

Serviceable

No

Automatically notify support

No

Alert Category

none

SNMP Trap ID

CIM Information

Prefix: IMM ID: 0044

User Response

Information only; no action is required.

- **4000002d-00000000 : DDNS setting changed to [arg1] by user [arg2].**

DDNS setting changed by user

May also be shown as 4000002d00000000 or 0x4000002d00000000

Severity

Info

Serviceable

No

Automatically notify support

No

Alert Category

none

SNMP Trap ID

CIM Information

Prefix: IMM ID: 0045

User Response

Information only; no action is required.

- **4000002e-00000000 : DDNS registration successful. The domain name is [arg1].**

DDNS registration and values

May also be shown as 4000002e00000000 or 0x4000002e00000000

Severity

Info

Serviceable

No

Automatically notify support

No

Alert Category

none

SNMP Trap ID**CIM Information**

Prefix: IMM ID: 0046

User Response

Information only; no action is required.

- **4000002f-00000000 : IPv6 enabled by user [arg1].**

IPv6 protocol is enabled by user

May also be shown as 4000002f00000000 or 0x4000002f00000000

Severity

Info

Serviceable

No

Automatically notify support

No

Alert Category

none

SNMP Trap ID**CIM Information**

Prefix: IMM ID: 0047

User Response

Information only; no action is required.

- **40000030-00000000 : IPv6 disabled by user [arg1].**

IPv6 protocol is disabled by user

May also be shown as 4000003000000000 or 0x4000003000000000

Severity

Info

Serviceable

No

Automatically notify support

No

Alert Category

none

SNMP Trap ID

CIM Information

Prefix: IMM ID: 0048

User Response

Information only; no action is required.

- **40000031-00000000 : IPv6 static IP configuration enabled by user [arg1].**

IPv6 static address assignment method is enabled by user

May also be shown as 4000003100000000 or 0x4000003100000000

Severity

Info

Serviceable

No

Automatically notify support

No

Alert Category

none

SNMP Trap ID

CIM Information

Prefix: IMM ID: 0049

User Response

Information only; no action is required.

- **40000032-00000000 : IPv6 DHCP enabled by user [arg1].**

IPv6 DHCP assignment method is enabled by user

May also be shown as 4000003200000000 or 0x4000003200000000

Severity

Info

Serviceable

No

Automatically notify support

No

Alert Category

none

SNMP Trap ID

CIM Information

Prefix: IMM ID: 0050

User Response

Information only; no action is required.

- **40000033-00000000 : IPv6 stateless auto-configuration enabled by user [arg1].**

IPv6 statless auto-assignment method is enabled by user

May also be shown as 4000003300000000 or 0x4000003300000000

Severity

Info

Serviceable

No

Automatically notify support

No

Alert Category

none

SNMP Trap ID

CIM Information

Prefix: IMM ID: 0051

User Response

Information only; no action is required.

- **40000034-00000000 : IPv6 static IP configuration disabled by user [arg1].**

IPv6 static assignment method is disabled by user

May also be shown as 4000003400000000 or 0x4000003400000000

Severity

Info

Serviceable

No

Automatically notify support

No

Alert Category

none

SNMP Trap ID

CIM Information

Prefix: IMM ID: 0052

User Response

Information only; no action is required.

- **40000035-00000000 : IPv6 DHCP disabled by user [arg1].**

IPv6 DHCP assignment method is disabled by user

May also be shown as 4000003500000000 or 0x4000003500000000

Severity

Info

Serviceable

No

Automatically notify support

No

Alert Category

none

SNMP Trap ID

CIM Information

Prefix: IMM ID: 0053

User Response

Information only; no action is required.

- **40000036-00000000 : IPv6 stateless auto-configuration disabled by user [arg1].**

IPv6 statless auto-assignment method is disabled by user

May also be shown as 4000003600000000 or 0x4000003600000000

Severity

Info

Serviceable

No

Automatically notify support

No

Alert Category

none

SNMP Trap ID

CIM Information

Prefix: IMM ID: 0054

User Response

Information only; no action is required.

- **40000037-00000000 : ENET[[arg1]] IPv6-LinkLocal:HstName=[arg2], IP@=[arg3] ,Pref=[arg4].**

IPv6 Link Local address is active

May also be shown as 4000003700000000 or 0x4000003700000000

Severity

Info

Serviceable

No

Automatically notify support

No

Alert Category

none

SNMP Trap ID

CIM Information

Prefix: IMM ID: 0055

User Response

Information only; no action is required.

- **40000038-00000000 : ENET[[arg1]] IPv6-Static:HstName=[arg2], IP@=[arg3] ,Pref=[arg4], GW@=[arg5].**

IPv6 Static address is active

May also be shown as 4000003800000000 or 0x4000003800000000

Severity

Info

Serviceable

No

Automatically notify support

No

Alert Category

none

SNMP Trap ID

CIM Information

Prefix: IMM ID: 0056

User Response

Information only; no action is required.

- **40000039-00000000 : ENET[[arg1]] DHCPv6-HSTN=[arg2], DN=[arg3], IP@[arg4], Pref=[arg5].**

IPv6 DHCP-assigned address is active

May also be shown as 4000003900000000 or 0x4000003900000000

Severity

Info

Serviceable

No

Automatically notify support

No

Alert Category

none

SNMP Trap ID

CIM Information

Prefix: IMM ID: 0057

User Response

Information only; no action is required.

- **4000003a-00000000 : IPv6 static address of network interface modified from [arg1] to [arg2] by user [arg3].**

A user modifies the IPv6 static address of a Management Controller

May also be shown as 4000003a00000000 or 0x4000003a00000000

Severity

Info

Serviceable

No

Automatically notify support

No

Alert Category

none

SNMP Trap ID**CIM Information**

Prefix: IMM ID: 0058

User Response

Information only; no action is required.

- **4000003b-00000000 : DHCPv6 failure, no IP address assigned.**

S DHCP6 server fails to assign an IP address to a Management Controller.

May also be shown as 4000003b00000000 or 0x4000003b00000000

Severity

Warning

Serviceable

No

Automatically notify support

No

Alert Category

none

SNMP Trap ID**CIM Information**

Prefix: IMM ID: 0059

User Response

Complete the following steps until the problem is solved:

1. Make sure that the IMM network cable is connected.
2. Make sure that there is a DHCPv6 server on the network that can assign an IP address to the IMM.

- **4000003c-00000000 : Platform Watchdog Timer expired for [arg1].**

An implementation has detected an OS Loader Watchdog Timer Expired

May also be shown as 4000003c00000000 or 0x4000003c00000000

Severity

Error

Serviceable

No

Automatically notify support

No

Alert Category

System - Loader timeout

SNMP Trap ID

26

CIM Information

Prefix: IMM ID: 0060

User Response

1. Reconfigure the watchdog timer to a higher value.
2. Make sure that the IMM Ethernet over USB interface is enabled.
3. Reinstall the RNDIS or cdc_ether device driver for the operating system.
4. Disable the watchdog.
5. Check the integrity of the installed operating system.

- **4000003d-00000000 : Telnet port number changed from [arg1] to [arg2] by user [arg3].**

A user has modified the telnet port number

May also be shown as 4000003d00000000 or 0x4000003d00000000

Severity

Info

Serviceable

No

Automatically notify support

No

Alert Category

none

SNMP Trap ID

CIM Information

Prefix: IMM ID: 0061

User Response

Information only; no action is required.

- **4000003e-00000000** : SSH port number changed from [arg1] to [arg2] by user [arg3].

A user has modified the SSH port number

May also be shown as 4000003e00000000 or 0x4000003e00000000

Severity

Info

Serviceable

No

Automatically notify support

No

Alert Category

none

SNMP Trap ID

CIM Information

Prefix: IMM ID: 0062

User Response

Information only; no action is required.

- **4000003f-00000000** : Web-HTTP port number changed from [arg1] to [arg2] by user [arg3].

A user has modified the Web HTTP port number

May also be shown as 4000003f00000000 or 0x4000003f00000000

Severity

Info

Serviceable

No

Automatically notify support

No

Alert Category

none

SNMP Trap ID

CIM Information

Prefix: IMM ID: 0063

User Response

Information only; no action is required.

- **40000040-00000000** : Web-HTTPS port number changed from [arg1] to [arg2] by user [arg3].

A user has modified the Web HTTPS port number

May also be shown as 4000004000000000 or 0x4000004000000000

Severity

Info

Serviceable

No

Automatically notify support

No

Alert Category

none

SNMP Trap ID

CIM Information

Prefix: IMM ID: 0064

User Response

Information only; no action is required.

- **40000041-00000000 : CIM/XML HTTP port number changed from [arg1] to [arg2] by user [arg3].**

A user has modified the CIM HTTP port number

May also be shown as 4000004100000000 or 0x4000004100000000

Severity

Info

Serviceable

No

Automatically notify support

No

Alert Category

none

SNMP Trap ID

CIM Information

Prefix: IMM ID: 0065

User Response

Information only; no action is required.

- **40000042-00000000 : CIM/XML HTTPS port number changed from [arg1] to [arg2] by user [arg3].**

A user has modified the CIM HTTPS port number

May also be shown as 4000004200000000 or 0x4000004200000000

Severity

Info

Serviceable

No

Automatically notify support

No

Alert Category

none

SNMP Trap ID**CIM Information**

Prefix: IMM ID: 0066

User Response

Information only; no action is required.

- **40000043-00000000 : SNMP Agent port number changed from [arg1] to [arg2] by user [arg3].**

A user has modified the SNMP Agent port number

May also be shown as 4000004300000000 or 0x4000004300000000

Severity

Info

Serviceable

No

Automatically notify support

No

Alert Category

none

SNMP Trap ID**CIM Information**

Prefix: IMM ID: 0067

User Response

Information only; no action is required.

- **40000044-00000000 : SNMP Traps port number changed from [arg1] to [arg2] by user [arg3].**

A user has modified the SNMP Traps port number

May also be shown as 4000004400000000 or 0x4000004400000000

Severity

Info

Serviceable

No

Automatically notify support

No

Alert Category

none

SNMP Trap ID

CIM Information

Prefix: IMM ID: 0068

User Response

Information only; no action is required.

- **40000045-00000000 : Syslog port number changed from [arg1] to [arg2] by user [arg3].**

A user has modified the Syslog receiver port number

May also be shown as 4000004500000000 or 0x4000004500000000

Severity

Info

Serviceable

No

Automatically notify support

No

Alert Category

none

SNMP Trap ID

CIM Information

Prefix: IMM ID: 0069

User Response

Information only; no action is required.

- **40000046-00000000 : Remote Presence port number changed from [arg1] to [arg2] by user [arg3].**

A user has modified the Remote Presence port number

May also be shown as 4000004600000000 or 0x4000004600000000

Severity

Info

Serviceable

No

Automatically notify support

No

Alert Category

none

SNMP Trap ID

CIM Information

Prefix: IMM ID: 0070

User Response

Information only; no action is required.

- **40000047-00000000 : LED [arg1] state changed to [arg2] by [arg3].**

A user has modified the state of an LED

May also be shown as 4000004700000000 or 0x4000004700000000

Severity

Info

Serviceable

No

Automatically notify support

No

Alert Category

none

SNMP Trap ID

CIM Information

Prefix: IMM ID: 0071

User Response

Information only; no action is required.

- **40000048-00000000 : Inventory data changed for device [arg1], new device data hash=[arg2], new master data hash=[arg3].**

Something has caused the physical inventory to change

May also be shown as 4000004800000000 or 0x4000004800000000

Severity

Info

Serviceable

No

Automatically notify support

No

Alert Category

none

SNMP Trap ID

CIM Information

Prefix: IMM ID: 0072

User Response

Information only; no action is required.

- **40000049-00000000 : SNMP [arg1] enabled by user [arg2].**

A user enabled SNMPv1 or SNMPv3 or Traps

May also be shown as 4000004900000000 or 0x4000004900000000

Severity

Info

Serviceable

No

Automatically notify support

No

Alert Category

none

SNMP Trap ID

CIM Information

Prefix: IMM ID: 0073

User Response

Information only; no action is required.

- **4000004a-00000000 : SNMP [arg1] disabled by user [arg2].**

A user disabled SNMPv1 or SNMPv3 or Traps

May also be shown as 4000004a00000000 or 0x4000004a00000000

Severity

Info

Serviceable

No

Automatically notify support

No

Alert Category

none

SNMP Trap ID**CIM Information**

Prefix: IMM ID: 0074

User Response

Information only; no action is required.

- **4000004b-00000000 : SNMPv1 [arg1] set by user [arg2]: Name=[arg3], AccessType=[arg4], Address=[arg5].**

A user changed the SNMP community string

May also be shown as 4000004b00000000 or 0x4000004b00000000

Severity

Info

Serviceable

No

Automatically notify support

No

Alert Category

none

SNMP Trap ID**CIM Information**

Prefix: IMM ID: 0075

User Response

Information only; no action is required.

- **4000004c-00000000 : LDAP Server configuration set by user [arg1]: SelectionMethod=[arg2], DomainName=[arg3], Server1=[arg4], Server2=[arg5], Server3=[arg6], Server4=[arg7].**

A user changed the LDAP server configuration

May also be shown as 4000004c00000000 or 0x4000004c00000000

Severity

Info

Serviceable

No

Automatically notify support

No

Alert Category

none

SNMP Trap ID

CIM Information

Prefix: IMM ID: 0076

User Response

Information only; no action is required.

- **4000004d-00000000 : LDAP set by user [arg1]: RootDN=[arg2], UIDSearchAttribute=[arg3], BindingMethod=[arg4], EnhancedRBS=[arg5], TargetName=[arg6], GroupFilter=[arg7], GroupAttribute=[arg8], LoginAttribute=[arg9].**

A user configured an LDAP Miscellaneous setting

May also be shown as 4000004d00000000 or 0x4000004d00000000

Severity

Info

Serviceable

No

Automatically notify support

No

Alert Category

none

SNMP Trap ID

CIM Information

Prefix: IMM ID: 0077

User Response

Information only; no action is required.

- **4000004e-00000000 : Serial Redirection set by user [arg1]: Mode=[arg2], BaudRate=[arg3], StopBits=[arg4], Parity=[arg5], SessionTerminateSequence=[arg6].**

A user configured the Serial Port mode

May also be shown as 4000004e00000000 or 0x4000004e00000000

Severity

Info

Serviceable

No

Automatically notify support

No

Alert Category

none

SNMP Trap ID

CIM Information

Prefix: IMM ID: 0078

User Response

Information only; no action is required.

- **4000004f-00000000 : Date and Time set by user [arg1]: Date=[arg2], Time=[arg3], DST Auto-adjust=[arg4], Timezone=[arg5].**

A user configured the Date and Time settings

May also be shown as 4000004f00000000 or 0x4000004f00000000

Severity

Info

Serviceable

No

Automatically notify support

No

Alert Category

none

SNMP Trap ID

CIM Information

Prefix: IMM ID: 0079

User Response

Information only; no action is required.

- **40000050-00000000 : Server General Settings set by user [arg1]: Name=[arg2], Contact=[arg3], Location=[arg4], Room=[arg5], RackID=[arg6], Rack U-position=[arg7].**

A user configured the Location setting

May also be shown as 4000005000000000 or 0x4000005000000000

Severity

Info

Serviceable

No

Automatically notify support

No

Alert Category

none

SNMP Trap ID

CIM Information

Prefix: IMM ID: 0080

User Response

Information only; no action is required.

- **40000051-00000000 : Server Power Off Delay set to [arg1] by user [arg2].**

A user configured the Server Power Off Delay

May also be shown as 4000005100000000 or 0x4000005100000000

Severity

Info

Serviceable

No

Automatically notify support

No

Alert Category

none

SNMP Trap ID

CIM Information

Prefix: IMM ID: 0081

User Response

Information only; no action is required.

- **40000052-00000000 : Server [arg1] scheduled for [arg2] at [arg3] by user [arg4].**

A user configured a Server Power action at a specific time

May also be shown as 4000005200000000 or 0x4000005200000000

Severity

Info

Serviceable

No

Automatically notify support

No

Alert Category

none

SNMP Trap ID

CIM Information

Prefix: IMM ID: 0082

User Response

Information only; no action is required.

- **40000053-00000000 : Server [arg1] scheduled for every [arg2] at [arg3] by user [arg4].**

A user configured a recurring Server Power Action

May also be shown as 4000005300000000 or 0x4000005300000000

Severity

Info

Serviceable

No

Automatically notify support

No

Alert Category

none

SNMP Trap ID

CIM Information

Prefix: IMM ID: 0083

User Response

Information only; no action is required.

- **40000054-00000000 : Server [arg1] [arg2] cleared by user [arg3].**

A user cleared a Server Power Action.

May also be shown as 4000005400000000 or 0x4000005400000000

Severity

Info

Serviceable

No

Automatically notify support

No

Alert Category

none

SNMP Trap ID

CIM Information

Prefix: IMM ID: 0084

User Response

Information only; no action is required.

- **40000055-00000000 : Synchronize time setting by user [arg1]: Mode=[arg2], NTPServerHost1=[arg3]:[arg4],NTPServerHost2=[arg5]:[arg6],NTPServerHost3=[arg7]:[arg8],NTPServerHost4=[arg9]**

A user configured the Date and Time synchronize settings

May also be shown as 4000005500000000 or 0x4000005500000000

Severity

Info

Serviceable

No

Automatically notify support

No

Alert Category

none

SNMP Trap ID**CIM Information**

Prefix: IMM ID: 0085

User Response

Information only; no action is required.

- **40000056-00000000 : SMTP Server set by user [arg1] to [arg2]:[arg3].**

A user configured the SMTP server

May also be shown as 4000005600000000 or 0x4000005600000000

Severity

Info

Serviceable

No

Automatically notify support

No

Alert Category

none

SNMP Trap ID**CIM Information**

Prefix: IMM ID: 0086

User Response

Information only; no action is required.

- **40000057-00000000 : Telnet [arg1] by user [arg2].**

A user enables or disables Telnet services

May also be shown as 4000005700000000 or 0x4000005700000000

Severity

Info

Serviceable

No

Automatically notify support

No

Alert Category

none

SNMP Trap ID

CIM Information

Prefix: IMM ID: 0087

User Response

Information only; no action is required.

- **40000058-00000000 : DNS servers set by user [arg1]: UseAdditionalServers=[arg2], PreferredDNStype=[arg3], IPv4Server1=[arg4], IPv4Server2=[arg5], IPv4Server3=[arg6], IPv6Server1=[arg7], IPv6Server2=[arg8], IPv6Server3=[arg9].**

A user configures the DNS servers

May also be shown as 4000005800000000 or 0x4000005800000000

Severity

Info

Serviceable

No

Automatically notify support

No

Alert Category

none

SNMP Trap ID

CIM Information

Prefix: IMM ID: 0088

User Response

Information only; no action is required.

- **40000059-00000000 : LAN over USB [arg1] by user [arg2].**

A user configured USB-LAN

May also be shown as 4000005900000000 or 0x4000005900000000

Severity

Info

Serviceable

No

Automatically notify support

No

Alert Category

none

SNMP Trap ID

CIM Information

Prefix: IMM ID: 0089

User Response

Information only; no action is required.

- **4000005a-00000000 : LAN over USB Port Forwarding set by user [arg1]: ExternalPort=[arg2], USB-LAN port=[arg3].**

A user configured USB-LAN port forwarding

May also be shown as 4000005a00000000 or 0x4000005a00000000

Severity

Info

Serviceable

No

Automatically notify support

No

Alert Category

none

SNMP Trap ID

CIM Information

Prefix: IMM ID: 0090

User Response

Information only; no action is required.

- **4000005b-00000000 : Secure Web services (HTTPS) [arg1] by user [arg2].**

A user enables or disables Secure web services

May also be shown as 4000005b00000000 or 0x4000005b00000000

Severity

Info

Serviceable

No

Automatically notify support

No

Alert Category

none

SNMP Trap ID

CIM Information

Prefix: IMM ID: 0091

User Response

Information only; no action is required.

- **4000005c-00000000 : Secure CIM/XML(HTTPS) [arg1] by user [arg2].**

A user enables or disables Secure CIM/XML services

May also be shown as 4000005c00000000 or 0x4000005c00000000

Severity

Info

Serviceable

No

Automatically notify support

No

Alert Category

none

SNMP Trap ID

CIM Information

Prefix: IMM ID: 0092

User Response

Information only; no action is required.

- **4000005d-00000000 : Secure LDAP [arg1] by user [arg2].**

A user enables or disables Secure LDAP services

May also be shown as 4000005d00000000 or 0x4000005d00000000

Severity

Info

Serviceable

No

Automatically notify support

No

Alert Category

none

SNMP Trap ID**CIM Information**

Prefix: IMM ID: 0093

User Response

Information only; no action is required.

- **4000005e-00000000 : SSH [arg1] by user [arg2].**

A user enables or disables SSH services

May also be shown as 4000005e00000000 or 0x4000005e00000000

Severity

Info

Serviceable

No

Automatically notify support

No

Alert Category

none

SNMP Trap ID**CIM Information**

Prefix: IMM ID: 0094

User Response

Information only; no action is required.

- **4000005f-00000000 : Server timeouts set by user [arg1]: EnableOSWatchdog=[arg2], OSWatchdogTimeout=[arg3], EnableLoaderWatchdog=[arg4], LoaderTimeout=[arg5].**

A user configures Server Timeouts

May also be shown as 4000005f00000000 or 0x4000005f00000000

Severity

Info

Serviceable

No

Automatically notify support

No

Alert Category

none

SNMP Trap ID**CIM Information****Prefix: IMM ID:** 0095**User Response**

Information only; no action is required.

- **40000060-00000000 : License key for [arg1] added by user [arg2].**

A user installs License Key

May also be shown as 4000006000000000 or 0x4000006000000000

Severity

Info

Serviceable

No

Automatically notify support

No

Alert Category

none

SNMP Trap ID**CIM Information****Prefix: IMM ID:** 0096**User Response**

Information only; no action is required.

- **40000061-00000000 : License key for [arg1] removed by user [arg2].**

A user removes a License Key

May also be shown as 4000006100000000 or 0x4000006100000000

Severity

Info

Serviceable

No

Automatically notify support

No

Alert Category

none

SNMP Trap ID**CIM Information**

Prefix: IMM ID: 0097

User Response

Information only; no action is required.

- **40000062-00000000 : Global Login General Settings set by user [arg1]: AuthenticationMethod=[arg2], LockoutPeriod=[arg3], SessionTimeout=[arg4].**

A user changes the Global Login General Settings

May also be shown as 4000006200000000 or 0x4000006200000000

Severity

Info

Serviceable

No

Automatically notify support

No

Alert Category

none

SNMP Trap ID**CIM Information**

Prefix: IMM ID: 0098

User Response

Information only; no action is required.

- **40000063-00000000 : Global Login Account Security set by user [arg1]: PasswordRequired=[arg2], PasswordExpirationPeriod=[arg3], MinimumPasswordReuseCycle=[arg4], MinimumPasswordLength=[arg5], MinimumPasswordChangeInterval=[arg6], MaxmumLoginFailures=[arg7], LockoutAfterMaxFailures=[arg8], MinimumDifferentCharacters=[arg9], DefaultIDExpired=[arg10], ChangePasswordFirstAccess=[arg11].**

A user changes the Global Login Account Security Settings to Legacy

May also be shown as 4000006300000000 or 0x4000006300000000

Severity

Info

Serviceable

No

Automatically notify support

No

Alert Category

none

SNMP Trap ID**CIM Information****Prefix: IMM ID:** 0099**User Response**

Information only; no action is required.

- **40000064-00000000 : User [arg1] created.**

A user account was created

May also be shown as 4000006400000000 or 0x4000006400000000

Severity

Info

Serviceable

No

Automatically notify support

No

Alert Category

none

SNMP Trap ID**CIM Information****Prefix: IMM ID:** 0100**User Response**

Information only; no action is required.

- **40000065-00000000 : User [arg1] removed.**

A user account was deleted

May also be shown as 4000006500000000 or 0x4000006500000000

Severity

Info

Serviceable

No

Automatically notify support

No

Alert Category

none

SNMP Trap ID**CIM Information**

Prefix: IMM ID: 0101

User Response

Information only; no action is required.

- **40000066-00000000 : User [arg1] password modified.**

A user account was changed

May also be shown as 4000006600000000 or 0x4000006600000000

Severity

Info

Serviceable

No

Automatically notify support

No

Alert Category

none

SNMP Trap ID**CIM Information**

Prefix: IMM ID: 0102

User Response

Information only; no action is required.

- **40000067-00000000 : User [arg1] role set to [arg2].**

A user account role assigned

May also be shown as 4000006700000000 or 0x4000006700000000

Severity

Info

Serviceable

No

Automatically notify support

No

Alert Category

none

SNMP Trap ID

CIM Information

Prefix: IMM ID: 0103

User Response

Information only; no action is required.

- **40000068-00000000 : User [arg1] custom privileges set: [arg2].**

User account privileges assigned

May also be shown as 4000006800000000 or 0x4000006800000000

Severity

Info

Serviceable

No

Automatically notify support

No

Alert Category

none

SNMP Trap ID

CIM Information

Prefix: IMM ID: 0104

User Response

Information only; no action is required.

- **40000069-00000000 : User [arg1] for SNMPv3 set: AuthenticationProtocol=[arg2], PrivacyProtocol=[arg3], AccessType=[arg4], HostforTraps=[arg5].**

User account SNMPv3 settings changed

May also be shown as 4000006900000000 or 0x4000006900000000

Severity

Info

Serviceable

No

Automatically notify support

No

Alert Category

none

SNMP Trap ID**CIM Information**

Prefix: IMM ID: 0105

User Response

Information only; no action is required.

- **4000006a-00000000 : SSH Client key added for user [arg1].**

User locally defined an SSH Client key

May also be shown as 4000006a00000000 or 0x4000006a00000000

Severity

Info

Serviceable

No

Automatically notify support

No

Alert Category

none

SNMP Trap ID**CIM Information**

Prefix: IMM ID: 0106

User Response

Information only; no action is required.

- **4000006b-00000000 : SSH Client key imported for user [arg1] from [arg2].**

User imported an SSH Client key

May also be shown as 4000006b00000000 or 0x4000006b00000000

Severity

Info

Serviceable

No

Automatically notify support

No

Alert Category

none

SNMP Trap ID

CIM Information

Prefix: IMM ID: 0107

User Response

Information only; no action is required.

- **4000006c-00000000 : SSH Client key removed from user [arg1].**
User removed an SSH Client key
May also be shown as 4000006c00000000 or 0x4000006c00000000

Severity

Info

Serviceable

No

Automatically notify support

No

Alert Category

none

SNMP Trap ID

CIM Information

Prefix: IMM ID: 0108

User Response

Information only; no action is required.

- **4000006d-00000000 : Management Controller [arg1]: Configuration saved to a file by user [arg2].**
A user saves a Management Controller configuration to a file.
May also be shown as 4000006d00000000 or 0x4000006d00000000

Severity

Info

Serviceable

No

Automatically notify support

No

Alert Category

none

SNMP Trap ID

CIM Information

Prefix: IMM ID: 0109

User Response

Information only; no action is required.

- **4000006e-00000000 : Alert Configuration Global Event Notification set by user [arg1]: RetryLimit=[arg2], RetryInterval=[arg3], EntryInterval=[arg4].**

A user changes the Global Event Notification settings.

May also be shown as 4000006e00000000 or 0x4000006e00000000

Severity

Info

Serviceable

No

Automatically notify support

No

Alert Category

none

SNMP Trap ID**CIM Information**

Prefix: IMM ID: 0110

User Response

Information only; no action is required.

- **4000006f-00000000 : Alert Recipient Number [arg1] updated: Name=[arg2], DeliveryMethod=[arg3], Address=[arg4], IncludeLog=[arg5], Enabled=[arg6], EnabledAlerts=[arg7], AllowedFilters=[arg8].**

A user adds or updates an Alert Recipient

May also be shown as 4000006f00000000 or 0x4000006f00000000

Severity

Info

Serviceable

No

Automatically notify support

No

Alert Category

none

SNMP Trap ID**CIM Information**

Prefix: IMM ID: 0111

User Response

Information only; no action is required.

- **40000070-00000000 : SNMP Traps enabled by user [arg1]: EnabledAlerts=[arg2], AllowedFilters=[arg3].**

A user enabled the SNMP Traps configuration

May also be shown as 4000007000000000 or 0x4000007000000000

Severity

Info

Serviceable

No

Automatically notify support

No

Alert Category

none

SNMP Trap ID

CIM Information

Prefix: IMM ID: 0112

User Response

Information only; no action is required.

- **40000071-00000000 : The power cap value changed from [arg1] watts to [arg2] watts by user [arg3].**

Power Cap values changed by user

May also be shown as 4000007100000000 or 0x4000007100000000

Severity

Info

Serviceable

No

Automatically notify support

No

Alert Category

none

SNMP Trap ID

CIM Information

Prefix: IMM ID: 0113

User Response

Information only; no action is required.

- **40000072-00000000** : The minimum power cap value changed from [arg1] watts to [arg2] watts.

Minimum Power Cap value changed

May also be shown as 4000007200000000 or 0x4000007200000000

Severity

Info

Serviceable

No

Automatically notify support

No

Alert Category

none

SNMP Trap ID**CIM Information**

Prefix: IMM ID: 0114

User Response

Information only; no action is required.

- **40000073-00000000** : The maximum power cap value changed from [arg1] watts to [arg2] watts.

Maximum Power Cap value changed

May also be shown as 4000007300000000 or 0x4000007300000000

Severity

Info

Serviceable

No

Automatically notify support

No

Alert Category

none

SNMP Trap ID**CIM Information**

Prefix: IMM ID: 0115

User Response

Information only; no action is required.

- **40000074-00000000** : The soft minimum power cap value changed from [arg1] watts to [arg2] watts.

Soft Minimum Power Cap value changed

May also be shown as 4000007400000000 or 0x4000007400000000

Severity

Info

Serviceable

No

Automatically notify support

No

Alert Category

none

SNMP Trap ID

CIM Information

Prefix: IMM ID: 0116

User Response

Information only; no action is required.

- **40000075-00000000** : The measured power value exceeded the power cap value.

Power exceeded cap

May also be shown as 4000007500000000 or 0x4000007500000000

Severity

Warning

Serviceable

No

Automatically notify support

No

Alert Category

Warning - Power

SNMP Trap ID

164

CIM Information

Prefix: IMM ID: 0117

User Response

Information only; no action is required.

- **40000076-00000000** : The new minimum power cap value exceeded the power cap value.

Minimum Power Cap exceeds Power Cap

May also be shown as 4000007600000000 or 0x4000007600000000

Severity

Warning

Serviceable

No

Automatically notify support

No

Alert Category

Warning - Power

SNMP Trap ID

164

CIM Information

Prefix: IMM ID: 0118

User Response

Information only; no action is required.

- **40000077-00000000 : Power capping was activated by user [arg1].**

Power capping activated by user

May also be shown as 4000007700000000 or 0x4000007700000000

Severity

Info

Serviceable

No

Automatically notify support

No

Alert Category

none

SNMP Trap ID

CIM Information

Prefix: IMM ID: 0119

User Response

Information only; no action is required.

- **40000078-00000000 : Power capping was deactivated by user [arg1].**

Power capping deactivated by user

May also be shown as 4000007800000000 or 0x4000007800000000

Severity

Info

Serviceable

No

Automatically notify support

No

Alert Category

none

SNMP Trap ID**CIM Information**

Prefix: IMM ID: 0120

User Response

Information only; no action is required.

- **40000079-00000000 : Static Power Savings mode has been turned on by user [arg1].**

Static Power Savings mode turned on by user

May also be shown as 4000007900000000 or 0x4000007900000000

Severity

Info

Serviceable

No

Automatically notify support

No

Alert Category

none

SNMP Trap ID**CIM Information**

Prefix: IMM ID: 0121

User Response

Information only; no action is required.

- **4000007a-00000000 : Static Power Savings mode has been turned off by user [arg1].**

Static Power Savings mode turned off by user

May also be shown as 4000007a00000000 or 0x4000007a00000000

Severity

Info

Serviceable

No

Automatically notify support

No

Alert Category

none

SNMP Trap ID

CIM Information

Prefix: IMM ID: 0122

User Response

Information only; no action is required.

- **4000007b-00000000 : Dynamic Power Savings mode has been turned on by user [arg1].**

Dynamic Power Savings mode turned on by user

May also be shown as 4000007b00000000 or 0x4000007b00000000

Severity

Info

Serviceable

No

Automatically notify support

No

Alert Category

none

SNMP Trap ID

CIM Information

Prefix: IMM ID: 0123

User Response

Information only; no action is required.

- **4000007c-00000000 : Dynamic Power Savings mode has been turned off by user [arg1].**

Dynamic Power Savings mode turned off by user

May also be shown as 4000007c00000000 or 0x4000007c00000000

Severity

Info

Serviceable

No

Automatically notify support

No

Alert Category

none

SNMP Trap ID

CIM Information

Prefix: IMM ID: 0124

User Response

Information only; no action is required.

- **4000007d-00000000 : Power cap and external throttling occurred.**

Power cap and external throttling occurred

May also be shown as 4000007d00000000 or 0x4000007d00000000

Severity

Info

Serviceable

No

Automatically notify support

No

Alert Category

none

SNMP Trap ID

CIM Information

Prefix: IMM ID: 0125

User Response

Information only; no action is required.

- **4000007e-00000000 : External throttling occurred.**

External throttling occurred

May also be shown as 4000007e00000000 or 0x4000007e00000000

Severity

Info

Serviceable

No

Automatically notify support

No

Alert Category

none

SNMP Trap ID

CIM Information

Prefix: IMM ID: 0126

User Response

Information only; no action is required.

- **4000007f-00000000 : Power cap throttling occurred.**

Power cap throttling occurred

May also be shown as 4000007f00000000 or 0x4000007f00000000

Severity

Info

Serviceable

No

Automatically notify support

No

Alert Category

none

SNMP Trap ID

CIM Information

Prefix: IMM ID: 0127

User Response

Information only; no action is required.

- **40000080-00000000 : Remote Control session started by user [arg1] in [arg2] mode.**

Remote Control session started

May also be shown as 4000008000000000 or 0x4000008000000000

Severity

Info

Serviceable

No

Automatically notify support

No

Alert Category

none

SNMP Trap ID

CIM Information

Prefix: IMM ID: 0128

User Response

Information only; no action is required.

- **40000081-00000000 : PXE boot requested by user [arg1].**

PXE boot requested

May also be shown as 4000008100000000 or 0x4000008100000000

Severity

Info

Serviceable

No

Automatically notify support

No

Alert Category

none

SNMP Trap ID

CIM Information

Prefix: IMM ID: 0129

User Response

Information only; no action is required.

- **40000082-00000000 : The measured power value has returned below the power cap value.**

Power exceeded cap recovered

May also be shown as 4000008200000000 or 0x4000008200000000

Severity

Info

Serviceable

No

Automatically notify support

No

Alert Category

Warning - Power

SNMP Trap ID

164

CIM Information

Prefix: IMM ID: 0130

User Response

Information only; no action is required.

- **40000083-00000000 : The new minimum power cap value has returned below the power cap value.**

Minimum Power Cap exceeds Power Cap recovered

May also be shown as 4000008300000000 or 0x4000008300000000

Severity

Info

Serviceable

No

Automatically notify support

No

Alert Category

Warning - Power

SNMP Trap ID

164

CIM Information

Prefix: IMM ID: 0131

User Response

Information only; no action is required.

- **40000084-00000000 : IMM firmware mismatch between nodes [arg1] and [arg2]. Please attempt to flash the IMM firmware to the same level on all nodes.**

A mismatch of IMM firmware has been detected between nodes

May also be shown as 4000008400000000 or 0x4000008400000000

Severity

Error

Serviceable

No

Automatically notify support

No

Alert Category

System - Other

SNMP Trap ID

22

CIM Information

Prefix: IMM ID: 0132

User Response

Attempt to flash the IMM firmware to the same level on all nodes.

- **40000085-00000000 : FPGA firmware mismatch between nodes [arg1] and [arg2]. Please attempt to flash the FPGA firmware to the same level on all nodes.**

A mismatch of FPGA firmware has been detected between nodes

May also be shown as 4000008500000000 or 0x4000008500000000

Severity

Error

Serviceable

No

Automatically notify support

No

Alert Category

System - Other

SNMP Trap ID

22

CIM Information

Prefix: IMM ID: 0133

User Response

Attempt to flash the FPGA firmware to the same level on all nodes.

- **40000086-00000000 : Test Call Home Generated by user [arg1].**

Test Call Home generated by user.

May also be shown as 4000008600000000 or 0x4000008600000000

Severity

Info

Serviceable

No

Automatically notify support

Yes

Alert Category

none

SNMP Trap ID

CIM Information

Prefix: IMM ID: 0134

User Response

Information only; no action is required.

- **40000087-00000000 : Manual Call Home by user [arg1]: [arg2].**

Manual Call Home by user.

May also be shown as 4000008700000000 or 0x4000008700000000

Severity

Info

Serviceable

No

Automatically notify support

Yes

Alert Category

none

SNMP Trap ID**CIM Information**

Prefix: IMM ID: 0135

User Response

Lenovo Support will address the problem.

- **40000088-00000000 : Management Controller [arg1]: Configuration restoration from a file by user [arg2] completed.**

This message is for the use case where a user restores a Management Controller configuration from a file and it completes.

May also be shown as 4000008800000000 or 0x4000008800000000

Severity

Info

Serviceable

No

Automatically notify support

No

Alert Category

none

SNMP Trap ID**CIM Information**

Prefix: IMM ID: 0136

User Response

Information only; no action is required.

- **40000089-00000000 : Management Controller [arg1]: Configuration restoration from a file by user [arg2] failed to complete.**

This message is for the use case where a user restores a Management Controller configuration from a file and the restoration fails to complete.

May also be shown as 4000008900000000 or 0x4000008900000000

Severity

Error

Serviceable

No

Automatically notify support

No

Alert Category

System - Other

SNMP Trap ID

22

CIM Information

Prefix: IMM ID: 0137

User Response

1. Turn off the server and disconnect it from the power source. You must disconnect the server from ac power to reset the IMM.
2. After 45 seconds, reconnect the server to the power source and turn on the server.
3. Retry the operation.

- **4000008a-00000000 : Management Controller [arg1]: Configuration restoration from a file by user [arg2] failed to start.**

This message is for the use case where a user restores a Management Controller configuration from a file and the restoration fails to start.

May also be shown as 4000008a00000000 or 0x4000008a00000000

Severity

Error

Serviceable

No

Automatically notify support

No

Alert Category

System - Other

SNMP Trap ID

22

CIM Information**Prefix: IMM ID:** 0138**User Response**

1. Turn off the server and disconnect it from the power source. You must disconnect the server from ac power to reset the IMM.
2. After 45 seconds, reconnect the server to the power source and turn on the server.
3. Retry the operation.

- **4000008b-00000000 : Storage [arg1] has changed.**

This message is for the use case where an IP address for the Storage Management has changed

May also be shown as 4000008b00000000 or 0x4000008b00000000

Severity

Info

Serviceable

No

Automatically notify support

No

Alert Category

System - IMM Network event

SNMP Trap ID

37

CIM Information**Prefix: IMM ID:** 0139**User Response**

Information only; no action is required.

- **4000008c-00000000 : Security: Userid: [arg1] had [arg2] login failures from a CIM client at IP address [arg3].**

This message is for the use case where a user has failed to log in to a Management Controller from CIM.

May also be shown as 4000008c00000000 or 0x4000008c00000000

Severity

Info

Serviceable

No

Automatically notify support

No

Alert Category

System - Remote Login

SNMP Trap ID

30

CIM Information

Prefix: IMM ID: 0140

User Response

Information only; no action is required.

- **4000008d-00000000 : Remote access attempt failed. Invalid userid or password received. Userid is [arg1] from a CIM client at IP address [arg2].**

This message is for the use case where a remote user has failed to establish a remote control session from CIM.

May also be shown as 4000008d00000000 or 0x4000008d00000000

Severity

Info

Serviceable

No

Automatically notify support

No

Alert Category

System - Remote Login

SNMP Trap ID

30

CIM Information

Prefix: IMM ID: 0141

User Response

Information only; no action is required.

- **4000008e-00000000 : Device [arg1] VPD is not valid.**

The VPD for a device is invalid

May also be shown as 4000008e00000000 or 0x4000008e00000000

Severity

Warning

Serviceable

No

Automatically notify support

No

Alert Category

System - Other

SNMP Trap ID

22

CIM Information

Prefix: IMM ID: 0142

User Response

Lenovo Support will address the problem.

- **4000008f-00000000 : The bare metal connection process has been started.**

Bare Metal Connection process has been started

May also be shown as 4000008f00000000 or 0x4000008f00000000

Severity

Info

Serviceable

No

Automatically notify support

No

Alert Category

System - Other

SNMP Trap ID

22

CIM Information

Prefix: IMM ID: 0143

User Response

Information only; no action is required.

- **40000090-00000000 : The bare metal update application reports a status of [arg1].**

Bare Metal Update Application Status

May also be shown as 4000009000000000 or 0x4000009000000000

Severity

Info

Serviceable

No

Automatically notify support

No

Alert Category

System - Other

SNMP Trap ID

22

CIM Information

Prefix: IMM ID: 0144

User Response

Information only; no action is required.

- **40000091-00000000 : User [arg1] has terminated an active console session.**

A user has terminated an active console session

May also be shown as 4000009100000000 or 0x4000009100000000

Severity

Info

Serviceable

No

Automatically notify support

No

Alert Category

none

SNMP Trap ID**CIM Information**

Prefix: IMM ID: 0145

User Response

Information only; no action is required.

- **40000092-00000000 : TKLM servers set by user [arg1]: TKLMServer1=[arg2] Port=[arg3], TKLMServer2=[arg4] Port=[arg5], TKLMServer3=[arg6] Port=[arg7], TKLMServer4=[arg8] Port=[arg9].**

A user configured the TKLM servers

May also be shown as 4000009200000000 or 0x4000009200000000

Severity

Info

Serviceable

No

Automatically notify support

No

Alert Category

none

SNMP Trap ID

CIM Information

Prefix: IMM ID: 0146

User Response

Information only; no action is required.

- **40000093-00000000 : TKLM servers device group set by user [arg1]: TKLMServerDeviceGroup=[arg2].**

A user configured the TKLM device group

May also be shown as 4000009300000000 or 0x4000009300000000

Severity

Info

Serviceable

No

Automatically notify support

No

Alert Category

none

SNMP Trap ID**CIM Information**

Prefix: IMM ID: 0147

User Response

Information only; no action is required.

- **40000094-00000000 : User [arg1] has generated a new encryption key pair and installed a self-signed certificate for the TKLM client.**

User generated a new encryption key pair and installed a self-signed certificate for the TKLM client

May also be shown as 4000009400000000 or 0x4000009400000000

Severity

Info

Serviceable

No

Automatically notify support

No

Alert Category

none

SNMP Trap ID

CIM Information

Prefix: IMM ID: 0148

User Response

Information only; no action is required.

- **40000095-00000000 : User [arg1] has generated a new encryption key and certificate signing request for the TKLM client.**

User generated a new encryption key and certificate signing request for the TKLM client

May also be shown as 4000009500000000 or 0x4000009500000000

Severity

Info

Serviceable

No

Automatically notify support

No

Alert Category

none

SNMP Trap ID

CIM Information

Prefix: IMM ID: 0149

User Response

Information only; no action is required.

- **40000096-00000000 : User [arg1] has imported a signed certificate for the TKLM client from [arg2].**

User imported a signed certificate for the TKLM client

May also be shown as 4000009600000000 or 0x4000009600000000

Severity

Info

Serviceable

No

Automatically notify support

No

Alert Category

none

SNMP Trap ID

CIM Information

Prefix: IMM ID: 0150

User Response

Information only; no action is required.

- **40000097-00000000 : User [arg1] has imported a server certificate for the TKLM server.**

User imported a server certificate for the TKLM Server

May also be shown as 4000009700000000 or 0x4000009700000000

Severity

Info

Serviceable

No

Automatically notify support

No

Alert Category

none

SNMP Trap ID**CIM Information**

Prefix: IMM ID: 0151

User Response

Information only; no action is required.

- **40000098-00000000 : The UEFI Definitions have been changed.**

UEFI Definitions change has been detected

May also be shown as 4000009800000000 or 0x4000009800000000

Severity

Info

Serviceable

No

Automatically notify support

No

Alert Category

none

SNMP Trap ID**CIM Information**

Prefix: IMM ID: 0152

User Response

Information only; no action is required.

- **40000099-00000000 : Security: Userid: [arg1] had [arg2] login failures from IPMI client at IP address [arg3].**

This message is for the use case where a user has failed to log in to a Management Controller from IPMI.

May also be shown as 4000009900000000 or 0x4000009900000000

Severity

Info

Serviceable

No

Automatically notify support

No

Alert Category

System - Remote Login

SNMP Trap ID

30

CIM Information

Prefix: IMM ID: 0153

User Response

Information only; no action is required.

- **4000009a-00000000 : Security: Userid: [arg1] had [arg2] login failures from SNMP client at IP address [arg3].**

This message is for the use case where a user has failed to access a Management Controller from SNMP.

May also be shown as 4000009a00000000 or 0x4000009a00000000

Severity

Info

Serviceable

No

Automatically notify support

No

Alert Category

System - Remote Login

SNMP Trap ID

30

CIM Information

Prefix: IMM ID: 0154

User Response

Information only; no action is required.

- **4000009b-00000000 : Security: Userid: [arg1] had [arg2] login failures from IPMI serial client.**
This message is for the use case where a user has failed to log in to a Management Controller from IPMI serial client

May also be shown as 4000009b00000000 or 0x4000009b00000000

Severity

Info

Serviceable

No

Automatically notify support

No

Alert Category

System - Remote Login

SNMP Trap ID

30

CIM Information

Prefix: IMM ID: 0155

User Response

Information only; no action is required.

- **4000009c-00000000 : Remote Login Successful. Login ID: [arg1] from [arg2] serial interface.**
This message is for the use case where a user successfully logs in to a Management Controller.

May also be shown as 4000009c00000000 or 0x4000009c00000000

Severity

Info

Serviceable

No

Automatically notify support

No

Alert Category

System - Remote Login

SNMP Trap ID

30

CIM Information

Prefix: IMM ID: 0156

User Response

Information only; no action is required.

- **4000009d-00000000 : Login ID: [arg1] from [arg2] at IP address [arg3] has logged off.**

This message is for the use case where a user has logged off of a Management Controller.

May also be shown as 4000009d00000000 or 0x4000009d00000000

Severity

Info

Serviceable

No

Automatically notify support

No

Alert Category

System - Remote Login

SNMP Trap ID

30

CIM Information

Prefix: IMM ID: 0157

User Response

Information only; no action is required.

- **4000009e-00000000 : Login ID: [arg1] from [arg2] at IP address [arg3] has been logged off.**

This message is for the use case where a user has been logged off of a Management Controller.

May also be shown as 4000009e00000000 or 0x4000009e00000000

Severity

Info

Serviceable

No

Automatically notify support

No

Alert Category

System - Remote Login

SNMP Trap ID

30

CIM Information

Prefix: IMM ID: 0158

User Response

Information only; no action is required.

- **4000009f-00000000 : User [arg1] has initiated a TKLM Server Connection Test to check connectivity to server [arg2].**

User initiated a TKLM Server Connection test.

May also be shown as 4000009f00000000 or 0x4000009f00000000

Severity

Info

Serviceable

No

Automatically notify support

No

Alert Category

none

SNMP Trap ID

CIM Information

Prefix: IMM ID: 0159

User Response

Information only; no action is required.

- **400000a0-00000000 : User [arg1] has initiated an SMTP Server Connection Test.**

User initiated an SMTP Server Connection test.

May also be shown as 400000a000000000 or 0x400000a000000000

Severity

Info

Serviceable

No

Automatically notify support

No

Alert Category

none

SNMP Trap ID

CIM Information

Prefix: IMM ID: 0160

User Response

Information only; no action is required.

- **400000a1-00000000 : UEFI Reported: [arg1].**

UEFI audit event logged.

May also be shown as 400000a100000000 or 0x400000a100000000

Severity

Info

Serviceable

No

Automatically notify support

No

Alert Category

none

SNMP Trap ID**CIM Information**

Prefix: IMM ID: 0161

User Response

Information only; no action is required.

- **400000a2-00000000 : User [arg1] has [arg2] file [arg3] from [arg4].**

User has mounted/unmounted file from URL or server

May also be shown as 400000a200000000 or 0x400000a200000000

Severity

Info

Serviceable

No

Automatically notify support

No

Alert Category

System - Other

SNMP Trap ID

22

CIM Information

Prefix: IMM ID: 0162

User Response

Information only; no action is required.

- **400000a3-00000000 : User [arg1] has set the SMTP Server reverse-path to [arg2].**

User set SMTP Server reverse-path address

May also be shown as 400000a300000000 or 0x400000a300000000

Severity

Info

Serviceable

No

Automatically notify support

No

Alert Category

System - Other

SNMP Trap ID

22

CIM Information

Prefix: IMM ID: 0163

User Response

Information only; no action is required.

- **400000a4-00000000 : User [arg1] has removed a certificate.**

User removed certificate

May also be shown as 400000a400000000 or 0x400000a400000000

Severity

Info

Serviceable

No

Automatically notify support

No

Alert Category

System - Other

SNMP Trap ID

22

CIM Information

Prefix: IMM ID: 0164

User Response

Information only; no action is required.

- **400000a5-00000000 : A certificate has been revoked.**

A certificate has been revoked

May also be shown as 400000a500000000 or 0x400000a500000000

Severity

Info

Serviceable

No

Automatically notify support

No

Alert Category

System - Other

SNMP Trap ID

22

CIM Information

Prefix: IMM ID: 0165

User Response

Information only; no action is required.

- **400000a6-00000000 : The server was restarted for an unknown reason.**

The server was restarted for an unknown reason

May also be shown as 400000a600000000 or 0x400000a600000000

Severity

Info

Serviceable

No

Automatically notify support

No

Alert Category

System - Other

SNMP Trap ID

22

CIM Information

Prefix: IMM ID: 0166

User Response

Information only; no action is required.

- **400000a7-00000000 : The server is restarted by chassis control command.**

Server is restarted by chassis control command

May also be shown as 400000a700000000 or 0x400000a700000000

Severity

Info

Serviceable

No

Automatically notify support

No

Alert Category

System - Other

SNMP Trap ID

22

CIM Information

Prefix: IMM ID: 0167

User Response

Information only; no action is required.

- **400000a8-00000000 : The server was reset via pushbutton.**

Server was reset via pushbutton

May also be shown as 400000a800000000 or 0x400000a800000000

Severity

Info

Serviceable

No

Automatically notify support

No

Alert Category

System - Other

SNMP Trap ID

22

CIM Information

Prefix: IMM ID: 0168

User Response

Information only; no action is required.

- **400000a9-00000000 : The server was powered-up via power pushbutton.**

Server was power-up via power pushbutton

May also be shown as 400000a900000000 or 0x400000a900000000

Severity

Info

Serviceable

No

Automatically notify support

No

Alert Category

System - Other

SNMP Trap ID

22

CIM Information**Prefix: IMM ID:** 0169**User Response**

Information only; no action is required.

- **400000aa-00000000 : The server was restarted when the watchdog expired..**

Server was restarted when the watchdog expired.

May also be shown as 400000aa00000000 or 0x400000aa00000000

Severity

Info

Serviceable

No

Automatically notify support

No

Alert Category

System - Other

SNMP Trap ID

22

CIM Information**Prefix: IMM ID:** 0170**User Response**

Information only; no action is required.

- **400000ab-00000000 : The server was restarted for OEM reason.**

Server was restarted for OEM reason

May also be shown as 400000ab00000000 or 0x400000ab00000000

Severity

Info

Serviceable

No

Automatically notify support

No

Alert Category

System - Other

SNMP Trap ID

22

CIM Information

Prefix: IMM ID: 0171

User Response

Information only; no action is required.

- **400000ac-00000000 : The server was automatically powered on because the power restore policy is set to always restore..**

Server was automatically powered on because the power restore policy is set to always restore.

May also be shown as 400000ac00000000 or 0x400000ac00000000

Severity

Info

Serviceable

No

Automatically notify support

No

Alert Category

System - Other

SNMP Trap ID

22

CIM Information

Prefix: IMM ID: 0172

User Response

Information only; no action is required.

- **400000ad-00000000 : The server was automatically powered on because the power restore policy is set to restore previous power state..**

Server was automatically powered on because the power restore policy is set to restore previous power state.

May also be shown as 400000ad00000000 or 0x400000ad00000000

Severity

Info

Serviceable

No

Automatically notify support

No

Alert Category

System - Other

SNMP Trap ID

22

CIM Information

Prefix: IMM ID: 0173

User Response

Information only; no action is required.

- **400000ae-00000000 : The server was reset via Platform Event Filter.**

Server was reset via Platform Event Filter

May also be shown as 400000ae00000000 or 0x400000ae00000000

Severity

Info

Serviceable

No

Automatically notify support

No

Alert Category

System - Other

SNMP Trap ID

22

CIM Information

Prefix: IMM ID: 0174

User Response

Information only; no action is required.

- **400000af-00000000 : The server was power-cycled via Platform Event Filter.**

Server was power-cycled via Platform Event Filter

May also be shown as 400000af00000000 or 0x400000af00000000

Severity

Info

Serviceable

No

Automatically notify support

No

Alert Category

System - Other

SNMP Trap ID

22

CIM Information

Prefix: IMM ID: 0175

User Response

Information only; no action is required.

- **400000b0-00000000 : The server was soft reset.**

Server was soft reset

May also be shown as 400000b000000000 or 0x400000b000000000

Severity

Info

Serviceable

No

Automatically notify support

No

Alert Category

System - Other

SNMP Trap ID

22

CIM Information

Prefix: IMM ID: 0176

User Response

Information only; no action is required.

- **400000b1-00000000 : The server was powered up via Real Time Clock (scheduled power on).**

Server was powered up via Real Time Clock (scheduled power on)

May also be shown as 400000b100000000 or 0x400000b100000000

Severity

Info

Serviceable

No

Automatically notify support

No

Alert Category

System - Other

SNMP Trap ID

22

CIM Information

Prefix: IMM ID: 0177

User Response

Information only; no action is required.

- **400000b2-00000000 : The server was powered off for an unknown reason.**

Server was powered off for an unknown reason

May also be shown as 400000b200000000 or 0x400000b200000000

Severity

Info

Serviceable

No

Automatically notify support

No

Alert Category

System - Other

SNMP Trap ID

22

CIM Information

Prefix: IMM ID: 0178

User Response

Information only; no action is required.

- **400000b3-00000000 : The server was powered off by chassis control command.**

Server was powered off by chassis control command

May also be shown as 400000b300000000 or 0x400000b300000000

Severity

Info

Serviceable

No

Automatically notify support

No

Alert Category

System - Other

SNMP Trap ID

22

CIM Information

Prefix: IMM ID: 0179

User Response

Information only; no action is required.

- **400000b4-00000000 : The server was powered off via pushbutton.**

Server was powered off via pushbutton

May also be shown as 400000b400000000 or 0x400000b400000000

Severity

Info

Serviceable

No

Automatically notify support

No

Alert Category

System - Other

SNMP Trap ID

22

CIM Information

Prefix: IMM ID: 0180

User Response

Information only; no action is required.

- **400000b5-00000000 : The server was powered off when the watchdog expired.**

Server was powered off when the watchdog expired.

May also be shown as 400000b500000000 or 0x400000b500000000

Severity

Info

Serviceable

No

Automatically notify support

No

Alert Category

System - Other

SNMP Trap ID

22

CIM Information

Prefix: IMM ID: 0181

User Response

Information only; no action is required.

- **400000b6-00000000 : The server stayed powered off because the power restore policy is set to always restore..**

Server stayed powered off because the power restore policy is set to always restore.

May also be shown as 400000b600000000 or 0x400000b600000000

Severity

Info

Serviceable

No

Automatically notify support

No

Alert Category

System - Other

SNMP Trap ID

22

CIM Information

Prefix: IMM ID: 0182

User Response

Information only; no action is required.

- **400000b7-00000000 : The server stayed powered off because the power restore policy is set to restore previous power state..**

Server stayed powered off because the power restore policy is set to restore previous power state.

May also be shown as 400000b700000000 or 0x400000b700000000

Severity

Info

Serviceable

No

Automatically notify support

No

Alert Category

System - Other

SNMP Trap ID

22

CIM Information

Prefix: IMM ID: 0183

User Response

Information only; no action is required.

- **400000b8-00000000 : The server was popowered off via Platform Event Filter.**

Server was power off via Platform Event Filter

May also be shown as 400000b800000000 or 0x400000b800000000

Severity

Info

Serviceable

No

Automatically notify support

No

Alert Category

System - Other

SNMP Trap ID

22

CIM Information

Prefix: IMM ID: 0184

User Response

Information only; no action is required.

- **400000b9-00000000 : The server was powered off via Real Time Clock (scheduled power off).**
Server was powered up via Real Time Clock (scheduled power off)
May also be shown as 400000b900000000 or 0x400000b900000000

Severity

Info

Serviceable

No

Automatically notify support

No

Alert Category

System - Other

SNMP Trap ID

22

CIM Information

Prefix: IMM ID: 0185

User Response

Information only; no action is required.

- **400000ba-00000000 : Management Controller [arg1] reset was initiated due to Power-On-Reset.**
Management Controller reset was initiated due to Power-On-Reset
May also be shown as 400000ba00000000 or 0x400000ba00000000

Severity

Info

Serviceable

No

Automatically notify support

No

Alert Category

System - Other

SNMP Trap ID

22

CIM Information

Prefix: IMM ID: 0186

User Response

Information only; no action is required.

- **400000bb-00000000 : Management Controller [arg1] reset was initiated by PRESET.**

Management Controller reset was initiated by PRESET

May also be shown as 400000bb00000000 or 0x400000bb00000000

Severity

Info

Serviceable

No

Automatically notify support

No

Alert Category

System - Other

SNMP Trap ID

22

CIM Information

Prefix: IMM ID: 0187

User Response

Information only; no action is required.

- **400000bc-00000000 : Management Controller [arg1] reset was initiated by CMM.**

Management Controller reset was initiated by CMM

May also be shown as 400000bc00000000 or 0x400000bc00000000

Severity

Info

Serviceable

No

Automatically notify support

No

Alert Category

System - Other

SNMP Trap ID

22

CIM Information

Prefix: IMM ID: 0188

User Response

Information only; no action is required.

- **400000bd-00000000 : Management Controller [arg1] reset was initiated by IMM firmware.**

Management Controller reset was initiated by IMM firmware

May also be shown as 400000bd00000000 or 0x400000bd00000000

Severity

Info

Serviceable

No

Automatically notify support

No

Alert Category

System - Other

SNMP Trap ID

22

CIM Information

Prefix: IMM ID: 0189

User Response

Information only; no action is required.

- **400000be-00000000 : The [arg1] certificate is expired and has been removed.**

Expired certificate has been removed

May also be shown as 400000be00000000 or 0x400000be00000000

Severity

Info

Serviceable

No

Automatically notify support

No

Alert Category

System - Other

SNMP Trap ID

22

CIM Information

Prefix: IMM ID: 0190

User Response

Information only; no action is required.

- **400000bf-00000000 : Operating System status has changed to [arg1].**

Operating System status change

May also be shown as 400000bf00000000 or 0x400000bf00000000

Severity

Info

Serviceable

No

Automatically notify support

No

Alert Category

System - Other

SNMP Trap ID

22

CIM Information

Prefix: IMM ID: 0191

User Response

Information only; no action is required.

- **400000c1-00000000 : System running in setup.**

System running in setup

May also be shown as 400000c100000000 or 0x400000c100000000

Severity

Info

Serviceable

No

Automatically notify support

No

Alert Category

System - Other

SNMP Trap ID

22

CIM Information

Prefix: IMM ID: 0193

User Response

Information only; no action is required.

- **400000c2-00000000 : Remote Control session started by user [arg1] in [arg2] mode has been closed.**

Remote Control session closed

May also be shown as 400000c200000000 or 0x400000c200000000

Severity

Info

Serviceable

No

Automatically notify support

No

Alert Category

System - Other

SNMP Trap ID

22

CIM Information

Prefix: IMM ID: 0194

User Response

Information only; no action is required.

- **400000c3-00000000 : Call Home to [arg1] failed to complete: [arg2].**

Call Home failed to complete.

May also be shown as 400000c300000000 or 0x400000c300000000

Severity

Info

Serviceable

No

Automatically notify support

No

Alert Category

System - Other

SNMP Trap ID

22

CIM Information**Prefix: IMM ID:** 0195**User Response**

Information only; no action is required.

- **400000c4-00000000 : IMM failed to log previous event [arg1].**

IMM failed to log a previous event.

May also be shown as 400000c400000000 or 0x400000c400000000

Severity

Info

Serviceable

No

Automatically notify support

No

Alert Category

System - Other

SNMP Trap ID

22

CIM Information**Prefix: IMM ID:** 0196**User Response**

Information only; no action is required.

- **400000c5-00000000 : UEFI deployment boot mode is enabled for NextBoot.**

UEFI deployment boot mode is enabled for NextBoot

May also be shown as 400000c500000000 or 0x400000c500000000

Severity

Info

Serviceable

No

Automatically notify support

No

Alert Category

System - Other

SNMP Trap ID

22

CIM Information

Prefix: IMM ID: 0197

User Response

Information only; no action is required.

- **400000c6-00000000 : UEFI deployment boot mode is enabled for NextAc.**

UEFI deployment boot mode is enabled for NextAC

May also be shown as 400000c600000000 or 0x400000c600000000

Severity

Info

Serviceable

No

Automatically notify support

No

Alert Category

System - Other

SNMP Trap ID

22

CIM Information

Prefix: IMM ID: 0198

User Response

Information only; no action is required.

- **400000c7-00000000 : UEFI deployment boot mode has been disabled.**

UEFI deployment boot mode has been disabled

May also be shown as 400000c700000000 or 0x400000c700000000

Severity

Info

Serviceable

No

Automatically notify support

No

Alert Category

System - Other

SNMP Trap ID

22

CIM Information

Prefix: IMM ID: 0199

User Response

Information only; no action is required.

- **400000c9-00000000 : User [arg1] made system [arg2] Encapsulation lite Mode.**

Encapsulation lite mode status change

May also be shown as 400000c900000000 or 0x400000c900000000

Severity

Info

Serviceable

No

Automatically notify support

No

Alert Category

System - Other

SNMP Trap ID

22

CIM Information

Prefix: IMM ID: 0201

User Response

Information only; no action is required.

- **400000ca-00000000 : Battery error was detected by RAID controller. The battery unit needs replacement.([arg1],[arg2],[arg3],[arg4],[arg5])**

Battery error was detected by RAID controller

May also be shown as 400000ca00000000 or 0x400000ca00000000

Severity

Info

Serviceable

No

Automatically notify support

No

Alert Category

System - Other

SNMP Trap ID

22

CIM Information

Prefix: IMM ID: 0202

User Response

Check storage documentation by LSI Event ID.

- **400000cb-00000000 : The RAID controller has problem with the battery. Please contact technical support to resolve this issue.([arg1],[arg2],[arg3],[arg4],[arg5])**

The RAID controller has problem with the battery

May also be shown as 400000cb00000000 or 0x400000cb00000000

Severity

Info

Serviceable

No

Automatically notify support

Yes

Alert Category

System - Other

SNMP Trap ID

22

CIM Information

Prefix: IMM ID: 0203

User Response

Check storage documentation by LSI Event ID.

- **400000cc-00000000 : The RAID controller detected unrecoverable error. The controller needs replacement.([arg1],[arg2],[arg3],[arg4],[arg5])**

The RAID controller detected unrecoverable error

May also be shown as 400000cc00000000 or 0x400000cc00000000

Severity

Info

Serviceable

No

Automatically notify support

Yes

Alert Category

System - Other

SNMP Trap ID

22

CIM Information

Prefix: IMM ID: 0204

User Response

Check storage documentation by LSI Event ID.

- **40000cd-00000000** : The RAID controller detected one or more problems. Please contact technical support for additional assistance.([arg1],[arg2],[arg3],[arg4],[arg5])

The RAID controller detected one or more problems

May also be shown as 40000cd00000000 or 0x40000cd00000000

Severity

Info

Serviceable

No

Automatically notify support

No

Alert Category

System - Other

SNMP Trap ID

22

CIM Information

Prefix: IMM ID: 0205

User Response

Check storage documentation by LSI Event ID.

- **40000ce-00000000** : The RAID controller detected one or more possible configuration changes within the subsystem. Please check the drive LED status. If necessary, contact technical support for additional assistance.([arg1],[arg2],[arg3],[arg4],[arg5])

The RAID controller detected one or more possible configuration changes within the subsystem

May also be shown as 40000ce00000000 or 0x40000ce00000000

Severity

Info

Serviceable

No

Automatically notify support

No

Alert Category

System - Other

SNMP Trap ID

22

CIM Information

Prefix: IMM ID: 0206

User Response

Check storage documentation by LSI Event ID.

- **400000cf-00000000 : Enclosure issue detected with one or more units. Please check the enclosure units to repair the problem.([arg1],[arg2],[arg3],[arg4],[arg5])**

Enclosure issue detected with one or more units

May also be shown as 400000cf00000000 or 0x400000cf00000000

Severity

Info

Serviceable

No

Automatically notify support

No

Alert Category

System - Other

SNMP Trap ID

22

CIM Information

Prefix: IMM ID: 0207

User Response

Lenovo Support will address the problem.

- **400000d0-00000000 : Connectivity issue detected with the enclosure. Please check your cable configurations to repair the problem.([arg1],[arg2],[arg3],[arg4],[arg5])**

Connectivity issue detected with the enclosure

May also be shown as 400000d000000000 or 0x400000d000000000

Severity

Info

Serviceable

No

Automatically notify support

No

Alert Category

System - Other

SNMP Trap ID

22

CIM Information

Prefix: IMM ID: 0208

User Response

Lenovo Support will address the problem.

- **400000d1-00000000 : Fan problem detected with the enclosure. Please check the enclosure unit fan for correct operation.([arg1],[arg2],[arg3],[arg4],[arg5])**

Fan problem detected with the enclosure

May also be shown as 400000d100000000 or 0x400000d100000000

Severity

Info

Serviceable

No

Automatically notify support

No

Alert Category

System - Other

SNMP Trap ID

22

CIM Information

Prefix: IMM ID: 0209

User Response

Lenovo Support will address the problem.

- **400000d2-00000000 : Enclosure power supply has problem. Please check the enclosure unit power supply for correct operation.([arg1],[arg2],[arg3],[arg4],[arg5])**

Enclosure power supply has problem

May also be shown as 400000d200000000 or 0x400000d200000000

Severity

Info

Serviceable

No

Automatically notify support

No

Alert Category

System - Other

SNMP Trap ID

22

CIM Information

Prefix: IMM ID: 0210

User Response

Lenovo Support will address the problem.

- **400000d3-00000000** : One or more virtual drive are in abnormal status that may cause unavailable virtual drive. Please check the event logs and if events are targeted to the same disk then replace the drive. If necessary, contact technical support for additional assistance.([arg1],[arg2],[arg3],[arg4],[arg5])

One or more virtual drive are in abnormal status that may cause unavailable virtual drive

May also be shown as 400000d300000000 or 0x400000d300000000

Severity

Info

Serviceable

No

Automatically notify support

No

Alert Category

System - Other

SNMP Trap ID

22

CIM Information

Prefix: IMM ID: 0211

User Response

Check storage documentation by LSI Event ID.

- **400000d4-00000000** : The RAID controller detected one or more possible configuration problem within the subsystem. Please check the event logs and if events are targeted to the same disk then replace the drive. If necessary, contact technical support for additional assistance.([arg1],[arg2],[arg3],[arg4],[arg5])

The RAID controller detected one or more possible configuration problem within the subsystem

May also be shown as 400000d400000000 or 0x400000d400000000

Severity

Info

Serviceable

No

Automatically notify support

No

Alert Category

System - Other

SNMP Trap ID

22

CIM Information

Prefix: IMM ID: 0212

User Response

Check storage documentation by LSI Event ID.

- **400000d5-00000000 : One or more virtual drive have problem. Please contact technical support to resolve this issue.([arg1],[arg2],[arg3],[arg4],[arg5])**

One or more virtual drive have problem

May also be shown as 400000d500000000 or 0x400000d500000000

Severity

Info

Serviceable

No

Automatically notify support

Yes

Alert Category

System - Other

SNMP Trap ID

22

CIM Information

Prefix: IMM ID: 0213

User Response

Check storage documentation by LSI Event ID.

- **400000d6-00000000 : Drive error was detected by RAID controller. Please contact technical support to resolve this issue.([arg1],[arg2],[arg3],[arg4],[arg5])**

Drive error was detected by RAID controller

May also be shown as 400000d600000000 or 0x400000d600000000

Severity

Info

Serviceable

No

Automatically notify support

Yes

Alert Category

System - Other

SNMP Trap ID

22

CIM Information

Prefix: IMM ID: 0214

User Response

Check storage documentation by LSI Event ID.

- **400000d7-00000000 : Drive error was detected by RAID controller. Please check the event logs and if events are targeted to the same disk then replace the drive. If necessary, contact technical support for additional assistance.([arg1],[arg2],[arg3],[arg4],[arg5])**

Drive error was detected by RAID controller

May also be shown as 400000d700000000 or 0x400000d700000000

Severity

Info

Serviceable

No

Automatically notify support

No

Alert Category

System - Other

SNMP Trap ID

22

CIM Information

Prefix: IMM ID: 0215

User Response

Check storage documentation by LSI Event ID.

- **80010002-0701ffff : Numeric sensor [NumericSensorElementName] going low (lower non-critical) has asserted. (CMOS Battery)**

This message is for the use case when an implementation has detected a Lower Non-critical sensor going low has asserted.

May also be shown as 800100020701ffff or 0x800100020701ffff

Severity

Warning

Serviceable

Yes

Automatically notify support

No

Alert Category

Warning - Voltage

SNMP Trap ID

13

CIM Information

Prefix: PLAT ID: 0476

User Response

Replace the system battery.

- **80010202-0701ffff : Numeric sensor [NumericSensorElementName] going low (lower critical) has asserted. (CMOS Battery)**

This message is for the use case when an implementation has detected a Lower Critical sensor going low has asserted.

May also be shown as 800102020701ffff or 0x800102020701ffff

Severity

Error

Serviceable

Yes

Automatically notify support

Yes

Alert Category

Critical - Voltage

SNMP Trap ID

1

CIM Information

Prefix: PLAT ID: 0480

User Response

If the specified sensor is CMOS battery, replace the system battery. If the specified sensor is Planar 3.3V or Planar 5V, (trained technician only) replace the system board. If the specified sensor is Planar 12V, complete the following steps until the problem is solved:

1. Check power supply n LED.
2. Remove the failing power supply.
3. Follow actions in "Power Problems and Solving Power Problems".
4. (Trained technician only) Replace the system board. (n = power supply number)

SysBrd 12V : SysBrd 3.3V : SysBrd 5V :

- **80010204-1d01ffff : Numeric sensor [NumericSensorElementName] going low (lower critical) has asserted. (Fan 1 Tach)**

This message is for the use case when an implementation has detected a Lower Critical sensor going low has asserted.

May also be shown as 800102041d01ffff or 0x800102041d01ffff

Severity

Error

Serviceable

Yes

Automatically notify support

No

Alert Category

Critical - Fan Failure

SNMP Trap ID

11

CIM Information

Prefix: PLAT ID: 0480

User Response

1. Reseat the failing fan n, which is indicated by a lit LED near the fan connector on the system board.
2. Replace the failing fan. (n = fan number)

- **80010204-1d02ffff : Numeric sensor [NumericSensorElementName] going low (lower critical) has asserted. (Fan 2 Tach)**

This message is for the use case when an implementation has detected a Lower Critical sensor going low has asserted.

May also be shown as 800102041d02ffff or 0x800102041d02ffff

Severity

Error

Serviceable

Yes

Automatically notify support

No

Alert Category

Critical - Fan Failure

SNMP Trap ID

11

CIM Information

Prefix: PLAT ID: 0480

User Response

1. Reseat the failing fan n, which is indicated by a lit LED near the fan connector on the system board.
2. Replace the failing fan. (n = fan number)

- **80010204-1d03ffff : Numeric sensor [NumericSensorElementName] going low (lower critical) has asserted. (Fan 3 Tach)**

This message is for the use case when an implementation has detected a Lower Critical sensor going low has asserted.

May also be shown as 800102041d03ffff or 0x800102041d03ffff

Severity

Error

Serviceable

Yes

Automatically notify support

No

Alert Category

Critical - Fan Failure

SNMP Trap ID

11

CIM Information**Prefix: PLAT ID: 0480****User Response**

1. Reseat the failing fan n, which is indicated by a lit LED near the fan connector on the system board.
2. Replace the failing fan. (n = fan number)

- **80010204-1d04ffff : Numeric sensor [NumericSensorElementName] going low (lower critical) has asserted. (Fan 4 Tach)**

This message is for the use case when an implementation has detected a Lower Critical sensor going low has asserted.

May also be shown as 800102041d04ffff or 0x800102041d04ffff

Severity

Error

Serviceable

Yes

Automatically notify support

No

Alert Category

Critical - Fan Failure

SNMP Trap ID

11

CIM Information**Prefix: PLAT ID: 0480****User Response**

1. Reseat the failing fan n, which is indicated by a lit LED near the fan connector on the system board.
2. Replace the failing fan. (n = fan number)

- **80010701-0701ffff : Numeric sensor [NumericSensorElementName] going high (upper non-critical) has asserted. (Ambient 1 Temp)**

This message is for the use case when an implementation has detected an Upper Non-critical sensor going high has asserted.

May also be shown as 800107010701ffff or 0x800107010701ffff

Severity

Warning

Serviceable

Yes

Automatically notify support

No

Alert Category

Warning - Temperature

SNMP Trap ID

12

CIM Information

Prefix: PLAT ID: 0490

User Response

1. Reduce the ambient temperature.
2. Ensure the air baffle is installed correctly.
3. Check the server airflow. Make sure that nothing is blocking the air from coming into or preventing the air from exiting the server.

- **80010701-0704ffff : Numeric sensor [NumericSensorElementName] going high (upper non-critical) has asserted. (PCIE Temp)**

This message is for the use case when an implementation has detected an Upper Non-critical sensor going high has asserted.

May also be shown as 800107010704ffff or 0x800107010704ffff

Severity

Warning

Serviceable

Yes

Automatically notify support

No

Alert Category

Warning - Temperature

SNMP Trap ID

12

CIM Information

Prefix: PLAT ID: 0490

User Response

1. Reduce the ambient temperature.
2. Ensure the air baffle is installed correctly.
3. Check the server airflow. Make sure that nothing is blocking the air from coming into or preventing the air from exiting the server.

- **80010701-0705ffff : Numeric sensor [NumericSensorElementName] going high (upper non-critical) has asserted. (CPU VRM Temp)**

This message is for the use case when an implementation has detected an Upper Non-critical sensor going high has asserted.

May also be shown as 800107010705ffff or 0x800107010705ffff

Severity

Warning

Serviceable

Yes

Automatically notify support

No

Alert Category

Warning - Temperature

SNMP Trap ID

12

CIM Information

Prefix: PLAT ID: 0490

User Response

1. Reduce the ambient temperature.
2. Ensure the air baffle is installed correctly.
3. Check the server airflow. Make sure that nothing is blocking the air from coming into or preventing the air from exiting the server.

- **80010701-2701ffff : Numeric sensor [NumericSensorElementName] going high (upper non-critical) has asserted. (Ambient 2 Temp)**

This message is for the use case when an implementation has detected an Upper Non-critical sensor going high has asserted.

May also be shown as 800107012701ffff or 0x800107012701ffff

Severity

Warning

Serviceable

Yes

Automatically notify support

No

Alert Category

Warning - Temperature

SNMP Trap ID

12

CIM Information

Prefix: PLAT ID: 0490

User Response

1. Reduce the ambient temperature.
2. Ensure the air baffle is installed correctly.
3. Check the server airflow. Make sure that nothing is blocking the air from coming into or preventing the air from exiting the server.

- **80010701-2d01ffff : Numeric sensor [NumericSensorElementName] going high (upper non-critical) has asserted. (PCH Temp)**

This message is for the use case when an implementation has detected an Upper Non-critical sensor going high has asserted.

May also be shown as 800107012d01ffff or 0x800107012d01ffff

Severity

Warning

Serviceable

Yes

Automatically notify support

No

Alert Category

Warning - Temperature

SNMP Trap ID

12

CIM Information

Prefix: PLAT ID: 0490

User Response

1. Reduce the ambient temperature.
2. Ensure the air baffle is installed correctly.

3. Check the server airflow. Make sure that nothing is blocking the air from coming into or preventing the air from exiting the server.

- **80010901-0701ffff : Numeric sensor [NumericSensorElementName] going high (upper critical) has asserted. (Ambient 1 Temp)**

This message is for the use case when an implementation has detected an Upper Critical sensor going high has asserted.

May also be shown as 800109010701ffff or 0x800109010701ffff

Severity

Error

Serviceable

Yes

Automatically notify support

No

Alert Category

Critical - Temperature

SNMP Trap ID

0

CIM Information

Prefix: PLAT ID: 0494

User Response

1. Reduce the ambient temperature.
2. Ensure the air baffle is installed correctly.
3. Check the server airflow. Make sure that nothing is blocking the air from coming into or preventing the air from exiting the server.

- **80010901-0704ffff : Numeric sensor [NumericSensorElementName] going high (upper critical) has asserted. (PCIe Temp)**

This message is for the use case when an implementation has detected an Upper Critical sensor going high has asserted.

May also be shown as 800109010704ffff or 0x800109010704ffff

Severity

Error

Serviceable

Yes

Automatically notify support

No

Alert Category

Critical - Temperature

SNMP Trap ID

0

CIM Information

Prefix: PLAT ID: 0494

User Response

1. Reduce the ambient temperature.
2. Ensure the air baffle is installed correctly.
3. Check the server airflow. Make sure that nothing is blocking the air from coming into or preventing the air from exiting the server.

- **80010901-0705ffff : Numeric sensor [NumericSensorElementName] going high (upper critical) has asserted. (CPU VRM Temp)**

This message is for the use case when an implementation has detected an Upper Critical sensor going high has asserted.

May also be shown as 800109010705ffff or 0x800109010705ffff

Severity

Error

Serviceable

Yes

Automatically notify support

No

Alert Category

Critical - Temperature

SNMP Trap ID

0

CIM Information

Prefix: PLAT ID: 0494

User Response

1. Reduce the ambient temperature.
2. Ensure the air baffle is installed correctly.
3. Check the server airflow. Make sure that nothing is blocking the air from coming into or preventing the air from exiting the server.

- **80010901-2701ffff : Numeric sensor [NumericSensorElementName] going high (upper critical) has asserted. (Ambient 2 Temp)**

This message is for the use case when an implementation has detected an Upper Critical sensor going high has asserted.

May also be shown as 800109012701ffff or 0x800109012701ffff

Severity

Error

Serviceable

Yes

Automatically notify support

No

Alert Category

Critical - Temperature

SNMP Trap ID

0

CIM Information

Prefix: PLAT ID: 0494

User Response

1. Reduce the ambient temperature.
2. Ensure the air baffle is installed correctly.
3. Check the server airflow. Make sure that nothing is blocking the air from coming into or preventing the air from exiting the server.

- **80010901-2d01ffff : Numeric sensor [NumericSensorElementName] going high (upper critical) has asserted. (PCH Temp)**

This message is for the use case when an implementation has detected an Upper Critical sensor going high has asserted.

May also be shown as 800109012d01ffff or 0x800109012d01ffff

Severity

Error

Serviceable

Yes

Automatically notify support

No

Alert Category

Critical - Temperature

SNMP Trap ID

0

CIM Information

Prefix: PLAT ID: 0494

User Response

1. Reduce the ambient temperature.
2. Ensure the air baffle is installed correctly.
3. Check the server airflow. Make sure that nothing is blocking the air from coming into or preventing the air from exiting the server.

- **80010902-0701ffff : Numeric sensor [NumericSensorElementName] going high (upper critical) has asserted. (SysBrd 12V)**

This message is for the use case when an implementation has detected an Upper Critical sensor going high has asserted.

May also be shown as 800109020701ffff or 0x800109020701ffff

Severity

Error

Serviceable

Yes

Automatically notify support

Yes

Alert Category

Critical - Voltage

SNMP Trap ID

1

CIM Information

Prefix: PLAT **ID:** 0494

User Response

If the specified sensor is Planar 3.3V or Planar 5V, (Trained technician only) replace the system board.

If the specified sensor is Planar 12V, complete the following steps until the problem is solved:

1. Check power supply n LED.
2. Remove the failing power supply.
3. (Trained technician only) Replace the system board. (n = power supply number)

SysBrd 3.3V : SysBrd 5V :

- **80010b01-0701ffff : Numeric sensor [NumericSensorElementName] going high (upper non-recoverable) has asserted. (Ambient 1 Temp)**

This message is for the use case when an implementation has detected an Upper Non-recoverable sensor going high has asserted.

May also be shown as 80010b010701ffff or 0x80010b010701ffff

Severity

Error

Serviceable

Yes

Automatically notify support

No

Alert Category

Critical - Temperature

SNMP Trap ID

0

CIM Information

Prefix: PLAT ID: 0498

User Response

1. Make sure that the fans are operating, that there are no obstructions to the airflow (front and rear of the server), that the air baffle is in place and correctly installed, and that the server cover is installed and completely closed.
2. Check the ambient temperature. You must be operating within the specifications (see Server Features and specifications for more information).
3. Make sure that the heat sink for microprocessor n is installed correctly.
4. (Trained technician only) Replace system board.

- **80010b01-0704ffff : Numeric sensor [NumericSensorElementName] going high (upper non-recoverable) has asserted. (PCIE Temp)**

This message is for the use case when an implementation has detected an Upper Non-recoverable sensor going high has asserted.

May also be shown as 80010b010704ffff or 0x80010b010704ffff

Severity

Error

Serviceable

Yes

Automatically notify support

No

Alert Category

Critical - Temperature

SNMP Trap ID

0

CIM Information

Prefix: PLAT ID: 0498

User Response

1. Make sure that the fans are operating, that there are no obstructions to the airflow (front and rear of the server), that the air baffle is in place and correctly installed, and that the server cover is installed and completely closed.
2. Check the ambient temperature. You must be operating within the specifications (see Server Features and specifications for more information).

3. Make sure that the heat sink for microprocessor n is installed correctly.
4. (Trained technician only) Replace system board.

- **80010b01-0705ffff : Numeric sensor [NumericSensorElementName] going high (upper non-recoverable) has asserted. (CPU VRM Temp)**

This message is for the use case when an implementation has detected an Upper Non-recoverable sensor going high has asserted.

May also be shown as 80010b010705ffff or 0x80010b010705ffff

Severity

Error

Serviceable

Yes

Automatically notify support

No

Alert Category

Critical - Temperature

SNMP Trap ID

0

CIM Information

Prefix: PLAT ID: 0498

User Response

1. Make sure that the fans are operating, that there are no obstructions to the airflow (front and rear of the server), that the air baffle is in place and correctly installed, and that the server cover is installed and completely closed.
2. Check the ambient temperature. You must be operating within the specifications (see Server Features and specifications for more information).
3. Make sure that the heat sink for microprocessor n is installed correctly.
4. (Trained technician only) Replace system board.

- **80010b01-2701ffff : Numeric sensor [NumericSensorElementName] going high (upper non-recoverable) has asserted. (Ambient 2 Temp)**

This message is for the use case when an implementation has detected an Upper Non-recoverable sensor going high has asserted.

May also be shown as 80010b012701ffff or 0x80010b012701ffff

Severity

Error

Serviceable

Yes

Automatically notify support

No

Alert Category

Critical - Temperature

SNMP Trap ID

0

CIM Information

Prefix: PLAT ID: 0498

User Response

1. Make sure that the fans are operating, that there are no obstructions to the airflow (front and rear of the server), that the air baffle is in place and correctly installed, and that the server cover is installed and completely closed.
2. Check the ambient temperature. You must be operating within the specifications (see Server Features and specifications for more information).
3. Make sure that the heat sink for microprocessor n is installed correctly.
4. (Trained technician only) Replace system board.

- **80010b01-2d01ffff : Numeric sensor [NumericSensorElementName] going high (upper non-recoverable) has asserted. (PCH Temp)**

This message is for the use case when an implementation has detected an Upper Non-recoverable sensor going high has asserted.

May also be shown as 80010b012d01ffff or 0x80010b012d01ffff

Severity

Error

Serviceable

Yes

Automatically notify support

No

Alert Category

Critical - Temperature

SNMP Trap ID

0

CIM Information

Prefix: PLAT ID: 0498

User Response

1. Make sure that the fans are operating, that there are no obstructions to the airflow (front and rear of the server), that the air baffle is in place and correctly installed, and that the server cover is installed and completely closed.
2. Check the ambient temperature. You must be operating within the specifications (see Server Features and specifications for more information).

3. Make sure that the heat sink for microprocessor n is installed correctly.
4. (Trained technician only) Replace system board.

- **80030006-2101ffff : Sensor [SensorElementName] has deasserted. (Sig Verify Fail)**

This message is for the use case when an implementation has detected a Sensor has deasserted.

May also be shown as 800300062101ffff or 0x800300062101ffff

Severity

Info

Serviceable

No

Automatically notify support

No

Alert Category

System - Other

SNMP Trap ID

CIM Information

Prefix: PLAT ID: 0509

User Response

No action; information only.

- **80030012-2301ffff : Sensor [SensorElementName] has deasserted. (OS RealTime Mod)**

This message is for the use case when an implementation has detected a Sensor has deasserted.

May also be shown as 800300122301ffff or 0x800300122301ffff

Severity

Info

Serviceable

No

Automatically notify support

No

Alert Category

System - Other

SNMP Trap ID

CIM Information

Prefix: PLAT ID: 0509

User Response

No action; information only.

- **80030021-0782ffff : Sensor [SensorElementName] has deasserted. (PCIe Dev LK Down)**

This message is for the use case when an implementation has detected a Sensor has deasserted.

May also be shown as 800300210782ffff or 0x800300210782ffff

Severity

Info

Serviceable

No

Automatically notify support

No

Alert Category

System - Other

SNMP Trap ID

CIM Information

Prefix: PLAT ID: 0509

User Response

No action; information only.

- **8003010c-2581ffff : Sensor [SensorElementName] has asserted. (Non-Auth DIMMs)**

This message is for the use case when an implementation has detected a Sensor has asserted.

May also be shown as 8003010c2581ffff or 0x8003010c2581ffff

Severity

Info

Serviceable

No

Automatically notify support

No

Alert Category

System - Other

SNMP Trap ID

CIM Information

Prefix: PLAT ID: 0508

User Response

1. Replace the power supply with higher rated power.
2. Reduce the total power consumption by removing newly added or unused option like drives or adapters.

- **8003010f-2101ffff : Sensor [SensorElementName] has asserted. (IMM FW Corrupted)**

This message is for the use case when an implementation has detected a Sensor has asserted.

May also be shown as 8003010f2101ffff or 0x8003010f2101ffff

Severity

Info

Serviceable

No

Automatically notify support

No

Alert Category

System - Other

SNMP Trap ID

CIM Information

Prefix: PLAT ID: 0508

User Response

1. Replace the power supply with higher rated power.
2. Reduce the total power consumption by removing newly added or unused option like drives or adapters.

- **80030112-0601ffff : Sensor [SensorElementName] has asserted. (SMM Mode)**

This message is for the use case when an implementation has detected a Sensor has asserted.

May also be shown as 800301120601ffff or 0x800301120601ffff

Severity

Info

Serviceable

No

Automatically notify support

No

Alert Category

System - Other

SNMP Trap ID

CIM Information

Prefix: PLAT ID: 0508

User Response

1. Replace the power supply with higher rated power.
2. Reduce the total power consumption by removing newly added or unused option like drives or adapters.

SMM Monitor :

- **80030121-0782ffff : Sensor [SensorElementName] has asserted. (PCIe Dev LK Down)**

This message is for the use case when an implementation has detected a Sensor has asserted.

May also be shown as 800301210782ffff or 0x800301210782ffff

Severity

Info

Serviceable

No

Automatically notify support

No

Alert Category

System - Other

SNMP Trap ID

CIM Information

Prefix: PLAT ID: 0508

User Response

1. Replace the power supply with higher rated power.
2. Reduce the total power consumption by removing newly added or unused option like drives or adapters.

- **8007000d-2582ffff : Sensor [SensorElementName] has transitioned to normal state. (RAID Vol State)**

This message is for the use case when an implementation has detected a Sensor transition to the normal state.

May also be shown as 8007000d2582ffff or 0x8007000d2582ffff

Severity

Info

Serviceable

No

Automatically notify support

No

Alert Category

Warning - Other

SNMP Trap ID

60

CIM Information

Prefix: PLAT ID: 0518

User Response

No action; information only.

- **8007010d-2582ffff : Sensor [SensorElementName] has transitioned from normal to non-critical state. (RAID Vol State)**

This message is for the use case when an implementation has detected a Sensor transitioned to non-critical from normal.

May also be shown as 8007010d2582ffff or 0x8007010d2582ffff

Severity

Warning

Serviceable

Yes

Automatically notify support

No

Alert Category

Warning - Other

SNMP Trap ID

60

CIM Information

Prefix: PLAT ID: 0520

User Response

None

- **8007010f-2201ffff : Sensor [SensorElementName] has transitioned from normal to non-critical state. (GPT Status)**

This message is for the use case when an implementation has detected a Sensor transitioned to non-critical from normal.

May also be shown as 8007010f2201ffff or 0x8007010f2201ffff

Severity

Warning

Serviceable

Yes

Automatically notify support

No

Alert Category

Warning - Other

SNMP Trap ID

60

CIM Information

Prefix: PLAT ID: 0520

User Response

Complete the following step to solve PCI I/O resource errors:

1. Go to F1 Setup-> System Settings-> Device and I/O ports-> PCI 64 bit Resource and choose enable.

- **8007010f-2582ffff : Sensor [SensorElementName] has transitioned from normal to non-critical state. (I/O Resources)**

This message is for the use case when an implementation has detected a Sensor transitioned to non-critical from normal.

May also be shown as 8007010f2582ffff or 0x8007010f2582ffff

Severity

Warning

Serviceable

Yes

Automatically notify support

No

Alert Category

Warning - Other

SNMP Trap ID

60

CIM Information

Prefix: PLAT ID: 0520

User Response

Complete the following step to solve PCI I/O resource errors:

1. Go to F1 Setup-> System Settings-> Device and I/O ports-> PCI 64 bit Resource and choose enable.

- **80070114-2201ffff : Sensor [SensorElementName] has transitioned from normal to non-critical state. (TPM Phy Pres Set)**

This message is for the use case when an implementation has detected a Sensor transitioned to non-critical from normal.

May also be shown as 800701142201ffff or 0x800701142201ffff

Severity

Warning

Serviceable

Yes

Automatically notify support

No

Alert Category

Warning - Other

SNMP Trap ID

60

CIM Information

Prefix: PLAT ID: 0520

User Response

1. Complete the administrative tasks that require the TPM physical presence switch to be in the ON position.
2. Restore the physical presence switch to the OFF position.
3. Reboot the system.
4. (Trained technician only) If the error continues, replace the planar.

- **80070128-2e01ffff : Sensor [SensorElementName] has transitioned from normal to non-critical state. (ME Recovery)**

This message is for the use case when an implementation has detected a Sensor transitioned to non-critical from normal.

May also be shown as 800701282e01ffff or 0x800701282e01ffff

Severity

Warning

Serviceable

Yes

Automatically notify support

No

Alert Category

Warning - Other

SNMP Trap ID

CIM Information

Prefix: PLAT ID: 0520

User Response

1. Restart IMM. If the error doesn't disappear, please proceed step 2.
2. Update to the latest level of iMM/uEFI code, please proceed step 3.
3. Replace node.

- **80070201-0301ffff : Sensor [SensorElementName] has transitioned to critical from a less severe state. (CPU 1 OverTemp)**

This message is for the use case when an implementation has detected a Sensor transitioned to critical from less severe.

May also be shown as 800702010301ffff or 0x800702010301ffff

Severity

Error

Serviceable

Yes

Automatically notify support

No

Alert Category

Critical - Temperature

SNMP Trap ID

0

CIM Information

Prefix: PLAT ID: 0522

User Response

1. Make sure that the fans are operating, that there are no obstructions to the airflow (front and rear of the server), that the air baffles are in place and correctly installed, and that the server cover is installed and completely closed.
2. Check the ambient temperature. You must be operating within the specifications (see Features and specifications for more information).
3. Make sure that the heat sink for microprocessor n is installed correctly.
4. (Trained technician only) Replace microprocessor n. (n = microprocessor number)

- **80070202-0701ffff : Sensor [SensorElementName] has transitioned to critical from a less severe state. (SysBrd Vol Fault)**

This message is for the use case when an implementation has detected a Sensor transitioned to critical from less severe.

May also be shown as 800702020701ffff or 0x800702020701ffff

Severity

Error

Serviceable

Yes

Automatically notify support

No

Alert Category

Critical - Voltage

SNMP Trap ID

1

CIM Information

Prefix: PLAT ID: 0522

User Response

1. Check the system-event log.
2. Check for an error LED on the system board.
3. Replace any failing device.
4. Check for a server firmware update. Important: Some cluster solutions require specific code levels or coordinated code updates. If the device is part of a cluster solution, verify that the latest level of code is supported for the cluster solution before you update the code.
5. (Trained technician only) Replace the system board.

- **80070204-0a01ffff : Sensor [SensorElementName] has transitioned to critical from a less severe state. (PS 1 Fan Fault)**

This message is for the use case when an implementation has detected a Sensor transitioned to critical from less severe.

May also be shown as 800702040a01ffff or 0x800702040a01ffff

Severity

Error

Serviceable

Yes

Automatically notify support

No

Alert Category

Critical - Fan Failure

SNMP Trap ID

11

CIM Information

Prefix: PLAT ID: 0522

User Response

1. Make sure that there are no obstructions, such as bundled cables, to the airflow from the power-supply fan.
2. Replace power supply n. (n = power supply number)

- **80070204-0a02ffff : Sensor [SensorElementName] has transitioned to critical from a less severe state. (PS 2 Fan Fault)**

This message is for the use case when an implementation has detected a Sensor transitioned to critical from less severe.

May also be shown as 800702040a02ffff or 0x800702040a02ffff

Severity

Error

Serviceable

Yes

Automatically notify support

No

Alert Category

Critical - Fan Failure

SNMP Trap ID

11

CIM Information

Prefix: PLAT ID: 0522

User Response

1. Make sure that there are no obstructions, such as bundled cables, to the airflow from the power-supply fan.
2. Replace power supply n. (n = power supply number)

- **80070208-0a01ffff : Sensor [SensorElementName] has transitioned to critical from a less severe state. (PS 1 Therm Fault)**

This message is for the use case when an implementation has detected a Sensor transitioned to critical from less severe.

May also be shown as 800702080a01ffff or 0x800702080a01ffff

Severity

Error

Serviceable

Yes

Automatically notify support

No

Alert Category

Critical - Power

SNMP Trap ID

4

CIM Information

Prefix: PLAT ID: 0522

User Response

1. Make sure that there are no obstructions, such as bundled cables, to the airflow from the power-supply fan.
2. Use the Lenovo Power Configurator utility to ensure current system power consumption is under limitation. For more information and to download the utility, go to <https://www.ibm.com/support/entry/myportal/docdisplay?Indocid=LNVO-PWRCONF>.
3. Replace power supply n. (n = power supply number)

- **80070208-0a02ffff : Sensor [SensorElementName] has transitioned to critical from a less severe state. (PS 2 Therm Fault)**

This message is for the use case when an implementation has detected a Sensor transitioned to critical from less severe.

May also be shown as 800702080a02ffff or 0x800702080a02ffff

Severity

Error

Serviceable

Yes

Automatically notify support

No

Alert Category

Critical - Power

SNMP Trap ID

4

CIM Information

Prefix: PLAT **ID:** 0522

User Response

1. Make sure that there are no obstructions, such as bundled cables, to the airflow from the power-supply fan.
2. Use the Lenovo Power Configurator utility to ensure current system power consumption is under limitation. For more information and to download the utility, go to <https://www.ibm.com/support/entry/myportal/docdisplay?Indocid=LNVO-PWRCONF>.
3. Replace power supply n. (n = power supply number)

- **8007020d-2582ffff : Sensor [SensorElementName] has transitioned to critical from a less severe state. (RAID Vol State)**

This message is for the use case when an implementation has detected a Sensor transitioned to critical from less severe.

May also be shown as 8007020d2582ffff or 0x8007020d2582ffff

Severity

Error

Serviceable

Yes

Automatically notify support

No

Alert Category

Critical - Other

SNMP Trap ID

50

CIM Information**Prefix: PLAT ID: 0522****User Response**

None

- **8007020f-2201ffff : Sensor [SensorElementName] has transitioned to critical from a less severe state. (TXT ACM Module)**

This message is for the use case when an implementation has detected a Sensor transitioned to critical from less severe.

May also be shown as 8007020f2201ffff or 0x8007020f2201ffff

Severity

Error

Serviceable

Yes

Automatically notify support

No

Alert Category

Critical - Other

SNMP Trap ID

50

CIM Information**Prefix: PLAT ID: 0522****User Response**

1. If enabling TXT is not required, disable TXT from the Setup Utility.
2. If enabling TXT is required, verify that the TPM is enabled and activated from the Setup Utility.
3. If the problem remains, contact your service representative.

- **8007020f-2582ffff : Sensor [SensorElementName] has transitioned to critical from a less severe state. (I/O Resources)**

This message is for the use case when an implementation has detected a Sensor transitioned to critical from less severe.

May also be shown as 8007020f2582ffff or 0x8007020f2582ffff

Severity

Error

Serviceable

Yes

Automatically notify support

No

Alert Category

Critical - Other

SNMP Trap ID

50

CIM Information

Prefix: PLAT ID: 0522

User Response

1. If enabling TXT is not required, disable TXT from the Setup Utility.
2. If enabling TXT is required, verify that the TPM is enabled and activated from the Setup Utility.
3. If the problem remains, contact your service representative.

- **80070214-2201ffff : Sensor [SensorElementName] has transitioned to critical from a less severe state. (TPM Lock)**

This message is for the use case when an implementation has detected a Sensor transitioned to critical from less severe.

May also be shown as 800702142201ffff or 0x800702142201ffff

Severity

Error

Serviceable

No

Automatically notify support

No

Alert Category

Critical - Other

SNMP Trap ID

50

CIM Information

Prefix: PLAT ID: 0522

User Response

1. Update the server firmware (see Recovering the server firmware).
2. If the problem persists, (trained technician only) replace the system board (see Removing the system board and Installing the system board).

- **80070219-0701ffff : Sensor [SensorElementName] has transitioned to critical from a less severe state. (SysBrd Fault)**

This message is for the use case when an implementation has detected a Sensor transitioned to critical from less severe.

May also be shown as 800702190701ffff or 0x800702190701ffff

Severity

Error

Serviceable

Yes

Automatically notify support

No

Alert Category

Critical - Other

SNMP Trap ID

50

CIM Information

Prefix: PLAT **ID:** 0522

User Response

1. Check for an error LED on the system board.
2. Check the system-event log.
3. Check for the system firmware version and update to the latest version. Important: Some cluster solutions require specific code levels or coordinated code updates. If the device is part of a cluster solution, verify that the latest level of code is supported for the cluster solution before you update the code.
4. Unplug and restore AC power cord, then, perform step 1 and 2 again.
5. If problems still occurred, (trained technician only) replace the system board.

- **80070228-2e01ffff : Sensor [SensorElementName] has transitioned to critical from a less severe state. (ME Error)**

This message is for the use case when an implementation has detected a Sensor transitioned to critical from less severe.

May also be shown as 800702282e01ffff or 0x800702282e01ffff

Severity

Error

Serviceable

Yes

Automatically notify support

No

Alert Category

Critical - Other

SNMP Trap ID

50

CIM Information

Prefix: PLAT ID: 0522

User Response

If the specified sensor is IPMB IO Error, Me Error or ME Flash Error, complete the following steps until the problem is solved:

1. Restart IMM. If the error still appears, proceed step 2.
2. Update the firmware (UEFI and IMM) to the latest level. If the error still appears, proceed step 3.
3. Replace the node.

ME Flash Error :

- **80070301-0301ffff : Sensor [SensorElementName] has transitioned to non-recoverable from a less severe state. (CPU 1 OverTemp)**

This message is for the use case when an implementation has detected a Sensor transitioned to non-recoverable from less severe.

May also be shown as 800703010301ffff or 0x800703010301ffff

Severity

Error

Serviceable

Yes

Automatically notify support

No

Alert Category

Critical - Temperature

SNMP Trap ID

0

CIM Information

Prefix: PLAT ID: 0524

User Response

1. Make sure that the fans are operating, that there are no obstructions to the airflow (front and rear of the server), that the air baffle is in place and correctly installed, and that the server cover is installed and completely closed.

2. Check the ambient temperature. You must be operating within the specifications (see Server Features and specifications for more information).
3. Make sure that the heat sink for microprocessor n is installed correctly.
4. (Trained technician only) Replace microprocessor n. (n = microprocessor number)

- **8007030d-2582ffff : Sensor [SensorElementName] has transitioned to non-recoverable from a less severe state. (RAID Vol State)**

This message is for the use case when an implementation has detected a Sensor transitioned to non-recoverable from less severe.

May also be shown as 8007030d2582ffff or 0x8007030d2582ffff

Severity

Error

Serviceable

Yes

Automatically notify support

No

Alert Category

Critical - Other

SNMP Trap ID

50

CIM Information

Prefix: PLAT ID: 0524

User Response

None

- **80070608-0a01ffff : Sensor [SensorElementName] has transitioned to non-recoverable. (PS1 12V OC Fault)**

This message is for the use case when an implementation has detected a Sensor transitioned to non-recoverable.

May also be shown as 800706080a01ffff or 0x800706080a01ffff

Severity

Error

Serviceable

Yes

Automatically notify support

No

Alert Category

Critical - Power

SNMP Trap ID

CIM Information**Prefix: PLAT ID: 0530****User Response**

If the specified sensor is PS n 12V OC Fault, complete the following steps until the problem is solved:

1. Use the Lenovo Power Configurator utility to determine current system power consumption. For more information and to download the utility, go to <https://www.ibm.com/support/entry/myportal/docdisplay?Indocid=LNVO-PWRCONF>.
2. Follow actions in "Power Problems and Solving Power Problems".

If the specified sensor is PS n 12V OV Fault, complete the following steps until the problem is solved:

1. Check power supply n LED.
2. Remove the failing power supply.
3. (Trained technician only) Replace the system board. (n = power supply number)

If the specified sensor is PS n 12V UV Fault, complete the following steps until the problem is solved:

1. Check power supply n LED.
2. Remove the failing power supply.
3. Follow actions in "Power Problems and Solving Power Problems".
4. (Trained technician only) Replace the system board. (n = power supply number)

If the specified sensor is PS n 12Vaux Fault, complete the following steps until the problem is solved:

1. Check power supply n LED.
2. Replace power supply n. (n = power supply number)

PS1 12V OV Fault : PS1 12V UV Fault : PS1 12Vaux Fault :

- **80070608-0a02ffff : Sensor [SensorElementName] has transitioned to non-recoverable. (PS2 12V OC Fault)**

This message is for the use case when an implementation has detected a Sensor transitioned to non-recoverable.

May also be shown as 800706080a02ffff or 0x800706080a02ffff

Severity

Error

Serviceable

Yes

Automatically notify support

No

Alert Category

Critical - Power

SNMP Trap ID

4

CIM Information**Prefix: PLAT ID: 0530****User Response**

If the specified sensor is PS n 12V OC Fault, complete the following steps until the problem is solved:

1. Use the Lenovo Power Configurator utility to determine current system power consumption. For more information and to download the utility, go to <https://www.ibm.com/support/entry/myportal/docdisplay?Indocid=LNVO-PWRCONF>.
2. Follow actions in "Power Problems and Solving Power Problems".

If the specified sensor is PS n 12V OV Fault, complete the following steps until the problem is solved:

1. Check power supply n LED.
2. Remove the failing power supply.
3. (Trained technician only) Replace the system board. (n = power supply number)

If the specified sensor is PS n 12V UV Fault, complete the following steps until the problem is solved:

1. Check power supply n LED.
2. Remove the failing power supply.
3. Follow actions in "Power Problems and Solving Power Problems".
4. (Trained technician only) Replace the system board. (n = power supply number)

If the specified sensor is PS n 12Vaux Fault, complete the following steps until the problem is solved:

1. Check power supply n LED.
2. Replace power supply n. (n = power supply number)

PS2 12V OV Fault : PS2 12V UV Fault : PS2 12Vaux Fault :

- **80070614-2201ffff : Sensor [SensorElementName] has transitioned to non-recoverable. (TPM Phy Pres Set)**

This message is for the use case when an implementation has detected a Sensor transitioned to non-recoverable.

May also be shown as 800706142201ffff or 0x800706142201ffff

Severity

Error

Serviceable

Yes

Automatically notify support

No

Alert Category

Critical - Other

SNMP Trap ID

50

CIM Information

Prefix: PLAT ID: 0530

User Response

1. Update the server firmware (see Recovering the server firmware).
2. If the problem persists, (trained technician only) replace the system board (see Removing the system board and Installing the system board).

- **80080025-3701ffff : Device [LogicalDeviceElementName] has been removed from unit [PhysicalPackageElementName]. (Thermal Board)**

This message is for the use case when an implementation has detected a Device was removed.

May also be shown as 800800253701ffff or 0x800800253701ffff

Severity

Info

Serviceable

No

Automatically notify support

No

Alert Category

System - Other

SNMP Trap ID

CIM Information

Prefix: PLAT ID: 0537

User Response

No action; information only.

- **80080125-3701ffff : Device [LogicalDeviceElementName] has been added. (Thermal Board)**

This message is for the use case when an implementation has detected a Device was inserted.

May also be shown as 800801253701ffff or 0x800801253701ffff

Severity

Info

Serviceable

No

Automatically notify support

No

Alert Category

System - Other

SNMP Trap ID

CIM Information

Prefix: PLAT ID: 0536

User Response

No action; information only.

- **80080128-2101ffff : Device [LogicalDeviceElementName] has been added. (Low Security Jmp)**

This message is for the use case when an implementation has detected a Device was inserted.
May also be shown as 800801282101ffff or 0x800801282101ffff

Severity

Info

Serviceable

No

Automatically notify support

No

Alert Category

System - Other

SNMP Trap ID

CIM Information

Prefix: PLAT ID: 0536

User Response

No action; information only.

- **800b0008-1301ffff : Redundancy [RedundancySetElementName] has been restored. (Power Unit)**

This message is for the use case when an implementation has detected Redundancy was Restored.

May also be shown as 800b00081301ffff or 0x800b00081301ffff

Severity

Info

Serviceable

No

Automatically notify support

No

Alert Category

Warning - Redundant Power Supply

SNMP Trap ID

10

CIM Information

Prefix: PLAT ID: 0561

User Response

No action; information only.

- **800b0108-1301ffff : Redundancy Lost for [RedundancySetElementName] has asserted. (Power Unit)**

This message is for the use case when Redundancy Lost has asserted.

May also be shown as 800b01081301ffff or 0x800b01081301ffff

Severity

Error

Serviceable

Yes

Automatically notify support

No

Alert Category

Critical - Redundant Power Supply

SNMP Trap ID

9

CIM Information

Prefix: PLAT ID: 0802

User Response

1. Check the LEDs for both power supplies.
2. Follow the actions in Power-supply LEDs.

• **806f0007-0301ffff : [ProcessorElementName] has Failed with IERR. (CPU 1)**

This message is for the use case when an implementation has detected a Processor Failed - IERR Condition.

May also be shown as 806f00070301ffff or 0x806f00070301ffff

Severity

Error

Serviceable

Yes

Automatically notify support

No

Alert Category

Critical - CPU

SNMP Trap ID

40

CIM Information

Prefix: PLAT ID: 0042

User Response

1. Make sure that the latest level of firmware and device drivers are installed for all adapters and standard devices, such as Ethernet, SCSI, and SAS. Important: Some cluster solutions require specific code levels or coordinated code updates. If the device is part of a cluster solution, verify that the latest level of code is supported for the cluster solution before you update the code.

2. Update the firmware (UEFI and IMM) to the latest level (Updating the firmware).
3. Run the DSA program.
4. Reseat the adapter.
5. Replace the adapter.
6. (Trained technician only) Replace microprocessor n.
7. (Trained technician only) Replace the system board. (n = microprocessor number)

- **806f0008-0a01ffff : [PowerSupplyElementName] has been added to container [PhysicalPackageElementName]. (Power Supply 1)**

This message is for the use case when an implementation has detected a Power Supply has been added.

May also be shown as 806f00080a01ffff or 0x806f00080a01ffff

Severity

Info

Serviceable

No

Automatically notify support

No

Alert Category

System - Other

SNMP Trap ID

CIM Information

Prefix: PLAT ID: 0084

User Response

No action; information only.

- **806f0008-0a02ffff : [PowerSupplyElementName] has been added to container [PhysicalPackageElementName]. (Power Supply 2)**

This message is for the use case when an implementation has detected a Power Supply has been added.

May also be shown as 806f00080a02ffff or 0x806f00080a02ffff

Severity

Info

Serviceable

No

Automatically notify support

No

Alert Category

System - Other

SNMP Trap ID

CIM Information

Prefix: PLAT ID: 0084

User Response

No action; information only.

- **806f0009-1301ffff : [PowerSupplyElementName] has been turned off. (Host Power)**

This message is for the use case when an implementation has detected a Power Unit that has been Disabled.

May also be shown as 806f00091301ffff or 0x806f00091301ffff

Severity

Info

Serviceable

No

Automatically notify support

No

Alert Category

System - Power Off

SNMP Trap ID

23

CIM Information

Prefix: PLAT ID: 0106

User Response

No action; information only.

- **806f000d-0400ffff : The Drive [StorageVolumeElementName] has been added. (Drive 0)**

This message is for the use case when an implementation has detected a Drive has been Added.

May also be shown as 806f000d0400ffff or 0x806f000d0400ffff

Severity

Info

Serviceable

No

Automatically notify support

No

Alert Category

System - Other

SNMP Trap ID

22

CIM Information**Prefix:** PLAT ID: 0162**User Response**

No action; information only.

- **806f000d-0401ffff : The Drive [StorageVolumeElementName] has been added. (Drive 1)**

This message is for the use case when an implementation has detected a Drive has been Added.

May also be shown as 806f000d0401ffff or 0x806f000d0401ffff

Severity

Info

Serviceable

No

Automatically notify support

No

Alert Category

System - Other

SNMP Trap ID

22

CIM Information**Prefix:** PLAT ID: 0162**User Response**

No action; information only.

- **806f000d-0402ffff : The Drive [StorageVolumeElementName] has been added. (Drive 2)**

This message is for the use case when an implementation has detected a Drive has been Added.

May also be shown as 806f000d0402ffff or 0x806f000d0402ffff

Severity

Info

Serviceable

No

Automatically notify support

No

Alert Category

System - Other

SNMP Trap ID

22

CIM Information**Prefix:** PLAT ID: 0162

User Response

No action; information only.

- **806f000d-0403ffff : The Drive [StorageVolumeElementName] has been added. (Drive 3)**

This message is for the use case when an implementation has detected a Drive has been Added.

May also be shown as 806f000d0403ffff or 0x806f000d0403ffff

Severity

Info

Serviceable

No

Automatically notify support

No

Alert Category

System - Other

SNMP Trap ID

22

CIM Information

Prefix: PLAT ID: 0162

User Response

No action; information only.

- **806f000d-0404ffff : The Drive [StorageVolumeElementName] has been added. (Drive 4)**

This message is for the use case when an implementation has detected a Drive has been Added.

May also be shown as 806f000d0404ffff or 0x806f000d0404ffff

Severity

Info

Serviceable

No

Automatically notify support

No

Alert Category

System - Other

SNMP Trap ID

22

CIM Information

Prefix: PLAT ID: 0162

User Response

No action; information only.

- **806f000d-0405ffff : The Drive [StorageVolumeElementName] has been added. (Drive 5)**
This message is for the use case when an implementation has detected a Drive has been Added.
May also be shown as 806f000d0405ffff or 0x806f000d0405ffff

Severity

Info

Serviceable

No

Automatically notify support

No

Alert Category

System - Other

SNMP Trap ID

22

CIM Information

Prefix: PLAT ID: 0162

User Response

No action; information only.

- **806f000d-0406ffff : The Drive [StorageVolumeElementName] has been added. (Drive 6)**
This message is for the use case when an implementation has detected a Drive has been Added.
May also be shown as 806f000d0406ffff or 0x806f000d0406ffff

Severity

Info

Serviceable

No

Automatically notify support

No

Alert Category

System - Other

SNMP Trap ID

22

CIM Information

Prefix: PLAT ID: 0162

User Response

No action; information only.

- **806f000d-0407ffff : The Drive [StorageVolumeElementName] has been added. (Drive 7)**

This message is for the use case when an implementation has detected a Drive has been Added.

May also be shown as 806f000d0407ffff or 0x806f000d0407ffff

Severity

Info

Serviceable

No

Automatically notify support

No

Alert Category

System - Other

SNMP Trap ID

22

CIM Information

Prefix: PLAT ID: 0162

User Response

No action; information only.

- **806f000d-0410ffff : The Drive [StorageVolumeElementName] has been added. (Ext Drive)**

This message is for the use case when an implementation has detected a Drive has been Added.

May also be shown as 806f000d0410ffff or 0x806f000d0410ffff

Severity

Info

Serviceable

No

Automatically notify support

No

Alert Category

System - Other

SNMP Trap ID

22

CIM Information

Prefix: PLAT ID: 0162

User Response

No action; information only.

- **806f000f-220101ff : The System [ComputerSystemElementName] has detected no memory in the system. (ABR Status)**

This message is for the use case when an implementation has detected that memory was detected in the system.

May also be shown as 806f000f220101ff or 0x806f000f220101ff

Severity

Error

Serviceable

Yes

Automatically notify support

No

Alert Category

Critical - Memory

SNMP Trap ID

41

CIM Information

Prefix: PLAT ID: 0794

User Response

1. Make sure the server meets the minimum configuration to start (see Power-supply LEDs).
2. Recover the server firmware from the backup page: a. Restart the server. b. At the prompt, press F3 to recover the firmware.
3. Update the server firmware on the primary page. Important: Some cluster solutions require specific code levels or coordinated code updates. If the device is part of a cluster solution, verify that the latest level of code is supported for the cluster solution before you update the code.
4. Remove components one at a time, restarting the server each time, to see if the problem goes away.
5. If the problem remains, (trained technician only) replace the system board.

Firmware Error : Sys Boot Status :

- **806f000f-220102ff : Subsystem [MemoryElementName] has insufficient memory for operation. (ABR Status)**

This message is for the use case when an implementation has detected that the usable Memory is insufficient for operation.

May also be shown as 806f000f220102ff or 0x806f000f220102ff

Severity

Error

Serviceable

Yes

Automatically notify support

No

Alert Category

Critical - Memory

SNMP Trap ID

CIM Information**Prefix:** PLAT ID: 0132**User Response**

1. Make sure the server meets the minimum configuration to start (see Power-supply LEDs).
2. Update the server firmware on the primary page. Important: Some cluster solutions require specific code levels or coordinated code updates. If the device is part of a cluster solution, verify that the latest level of code is supported for the cluster solution before you update the code.
3. (Trained technician only) Replace the system board.

Firmware Error : Sys Boot Status :

- **806f000f-220103ff : The System [ComputerSystemElementName] encountered firmware error - unrecoverable boot device failure. (ABR Status)**

This message is for the use case when an implementation has detected that System Firmware Error Unrecoverable boot device failure has occurred.

May also be shown as 806f000f220103ff or 0x806f000f220103ff

Severity

Error

Serviceable

Yes

Automatically notify support

No

Alert Category

Critical - Hard Disk drive

SNMP Trap ID

5

CIM Information**Prefix:** PLAT ID: 0770**User Response**

This is a UEFI detected event. The UEFI(POST) error for this event can be found in the logged IMM message text. Please refer to the UEFI(POST) error code in the "UEFI(POST) error code" section of the Information Center for the appropriate user response. Firmware Error : Sys Boot Status :

- **806f000f-220104ff : The System [ComputerSystemElementName]has encountered a motherboard failure. (ABR Status)**

This message is for the use case when an implementation has detected that a fatal motherboard failure in the system.

May also be shown as 806f000f220104ff or 0x806f000f220104ff

Severity

Error

Serviceable

Yes

Automatically notify support

No

Alert Category

Critical - Other

SNMP Trap ID

50

CIM Information**Prefix: PLAT ID: 0795****User Response**

This is a UEFI detected event. The UEFI(POST) error for this event can be found in the logged IMM message text. Please refer to the UEFI(POST) error code in the "UEFI(POST) error code" section of the Information Center for the appropriate user response. Firmware Error : Sys Boot Status :

- **806f000f-220107ff : The System [ComputerSystemElementName] encountered firmware error - unrecoverable keyboard failure. (ABR Status)**

This message is for the use case when an implementation has detected that System Firmware Error Unrecoverable Keyboard failure has occurred.

May also be shown as 806f000f220107ff or 0x806f000f220107ff

Severity

Error

Serviceable

Yes

Automatically notify support

No

Alert Category

Critical - Other

SNMP Trap ID

50

CIM Information**Prefix: PLAT ID: 0764****User Response**

This is a UEFI detected event. The UEFI(POST) error for this event can be found in the logged IMM message text. Please refer to the UEFI(POST) error code in the "UEFI(POST) error code" section of the Information Center for the appropriate user response. Firmware Error : Sys Boot Status :

- **806f000f-22010aff : The System [ComputerSystemElementName] encountered firmware error - no video device detected. (ABR Status)**

This message is for the use case when an implementation has detected that System Firmware Error No video device detected has occurred.

May also be shown as 806f000f22010aff or 0x806f000f22010aff

Severity

Error

Serviceable

Yes

Automatically notify support

No

Alert Category

Critical - Other

SNMP Trap ID

50

CIM Information

Prefix: PLAT **ID:** 0766

User Response

This is a UEFI detected event. The UEFI(POST) error for this event can be found in the logged IMM message text. Please refer to the UEFI(POST) error code in the "UEFI(POST) error code" section of the Information Center for the appropriate user response. Firmware Error : Sys Boot Status :

- **806f000f-22010bff : Firmware BIOS (ROM) corruption was detected on system [ComputerSystemElementName] during POST. (ABR Status)**

Firmware BIOS (ROM) corruption was detected on the system during POST.

May also be shown as 806f000f22010bff or 0x806f000f22010bff

Severity

Error

Serviceable

Yes

Automatically notify support

No

Alert Category

Critical - Other

SNMP Trap ID

50

CIM Information

Prefix: PLAT **ID:** 0850

User Response

1. Make sure the server meets the minimum configuration to start (see Power-supply LEDs).

2. Recover the server firmware from the backup page: a.Restart the server. b.At the prompt, press F3 to recover the firmware.
3. Update the server firmware to the latest level (see Updating the firmware). Important: Some cluster solutions require specific code levels or coordinated code updates. If the device is part of a cluster solution, verify that the latest level of code is supported for the cluster solution before you update the code.
4. Remove components one at a time, restarting the server each time, to see if the problem goes away.
5. If the problem remains, (trained service technician) replace the system board.

Firmware Error : Sys Boot Status :

- **806f000f-22010cff : CPU voltage mismatch detected on [ProcessorElementName]. (ABR Status)**

This message is for the use case when an implementation has detected a CPU voltage mismatch with the socket voltage.

May also be shown as 806f000f22010cff or 0x806f000f22010cff

Severity

Error

Serviceable

Yes

Automatically notify support

No

Alert Category

Critical - CPU

SNMP Trap ID

40

CIM Information

Prefix: PLAT ID: 0050

User Response

This is a UEFI detected event. The UEFI diagnostic code for this event can be found in the logged IMM message text. Please refer to the UEFI diagnostic code in the "UEFI diagnostic code" section of the Info Center for the appropriate user response. Firmware Error : Sys Boot Status :

- **806f000f-2201ffff : The System [ComputerSystemElementName] encountered a POST Error. (ABR Status)**

This message is for the use case when an implementation has detected a Post Error.

May also be shown as 806f000f2201ffff or 0x806f000f2201ffff

Severity

Error

Serviceable

Yes

Automatically notify support

No

Alert Category

Critical - Other

SNMP Trap ID

50

CIM Information

Prefix: PLAT ID: 0184

User Response

This is a UEFI detected event. The UEFI(POST) error code for this event can be found in the logged IMM message text. Please refer to the UEFI(POST) error code in the "UEFI(POST) error code" section of the Information Center for the appropriate user response. Firmware Error : Sys Boot Status :

- **806f0013-1701ffff : A diagnostic interrupt has occurred on system [ComputerSystemElementName]. (NMI State)**

This message is for the use case when an implementation has detected a Front Panel NMI / Diagnostic Interrupt.

May also be shown as 806f00131701ffff or 0x806f00131701ffff

Severity

Error

Serviceable

Yes

Automatically notify support

No

Alert Category

Critical - Other

SNMP Trap ID

50

CIM Information

Prefix: PLAT ID: 0222

User Response

If the NMI button has not been pressed, complete the following steps:

1. Make sure that the NMI button is not pressed.
2. Replace the operator information panel cable.
3. Replace the operator information panel.

- **806f001e-2201ffff : No bootable media available for system [ComputerSystemElementName]. (No Boot Device)**

This message is for the use case when an implementation has detected a System with No Bootable Media.

May also be shown as 806f001e2201ffff or 0x806f001e2201ffff

Severity

Info

Serviceable

No

Automatically notify support

No

Alert Category

System - Other

SNMP Trap ID**CIM Information**

Prefix: PLAT ID: 0286

User Response

No action; information only.

- **806f0021-2201ffff : Fault in slot [PhysicalConnectorSystemElementName] on system [ComputerSystemElementName]. (No Op ROM Space)**

This message is for the use case when an implementation has detected a Fault in a slot.

May also be shown as 806f00212201ffff or 0x806f00212201ffff

Severity

Error

Serviceable

Yes

Automatically notify support

Yes

Alert Category

Critical - Other

SNMP Trap ID

50

CIM Information

Prefix: PLAT ID: 0330

User Response

1. Check the PCI LED.
2. Reseat the affected adapters and riser card.
3. Update the server firmware (UEFI and IMM) and adapter firmware. Important: Some cluster solutions require specific code levels or coordinated code updates. If the device is part of a cluster solution, verify that the latest level of code is supported for the cluster solution before you update the code.
4. Replace the affected adapters.

5. Replace the riser card.
6. (Trained service technicians only) Replace the system board.

- **806f0021-2582ffff : Fault in slot [PhysicalConnectorSystemElementName] on system [ComputerSystemElementName]. (All PCI Error)**

This message is for the use case when an implementation has detected a Fault in a slot.

May also be shown as 806f00212582ffff or 0x806f00212582ffff

Severity

Error

Serviceable

Yes

Automatically notify support

Yes

Alert Category

Critical - Other

SNMP Trap ID

50

CIM Information

Prefix: PLAT **ID:** 0330

User Response

1. Check the PCI LED.
2. Reseat the affected adapters and riser card.
3. Update the server firmware (UEFI and IMM) and adapter firmware. Important: Some cluster solutions require specific code levels or coordinated code updates. If the device is part of a cluster solution, verify that the latest level of code is supported for the cluster solution before you update the code.
4. Replace the affected adapters.
5. Replace the riser card.
6. (Trained service technicians only) Replace the system board.

One of PCI Error :

- **806f0021-3001ffff : Fault in slot [PhysicalConnectorSystemElementName] on system [ComputerSystemElementName]. (PCI 1)**

This message is for the use case when an implementation has detected a Fault in a slot.

May also be shown as 806f00213001ffff or 0x806f00213001ffff

Severity

Error

Serviceable

Yes

Automatically notify support

Yes

Alert Category

Critical - Other

SNMP Trap ID

50

CIM Information

Prefix: PLAT ID: 0330

User Response

1. Check the PCI LED.
 2. Reseat the affected adapters and riser card.
 3. Update the server firmware (UEFI and IMM) and adapter firmware. Important: Some cluster solutions require specific code levels or coordinated code updates. If the device is part of a cluster solution, verify that the latest level of code is supported for the cluster solution before you update the code.
 4. Replace the affected adapters.
 5. Replace the riser card.
 6. (Trained service technicians only) Replace the system board.
- **806f0021-3002ffff : Fault in slot [PhysicalConnectorSystemElementName] on system [ComputerSystemElementName]. (PCI 2)**

This message is for the use case when an implementation has detected a Fault in a slot.

May also be shown as 806f00213002ffff or 0x806f00213002ffff

Severity

Error

Serviceable

Yes

Automatically notify support

Yes

Alert Category

Critical - Other

SNMP Trap ID

50

CIM Information

Prefix: PLAT ID: 0330

User Response

1. Check the PCI LED.

2. Reseat the affected adapters and riser card.
3. Update the server firmware (UEFI and IMM) and adapter firmware. Important: Some cluster solutions require specific code levels or coordinated code updates. If the device is part of a cluster solution, verify that the latest level of code is supported for the cluster solution before you update the code.
4. Replace the affected adapters.
5. Replace the riser card.
6. (Trained service technicians only) Replace the system board.

- **806f0023-2101ffff : Watchdog Timer expired for [WatchdogElementName]. (IPMI Watchdog)**

This message is for the use case when an implementation has detected a Watchdog Timer Expired.

May also be shown as 806f00232101ffff or 0x806f00232101ffff

Severity

Info

Serviceable

No

Automatically notify support

No

Alert Category

System - Other

SNMP Trap ID

CIM Information

Prefix: PLAT **ID:** 0368

User Response

No action; information only.

- **806f0107-0301ffff : An Over-Temperature Condition has been detected on [ProcessorElementName]. (CPU 1)**

This message is for the use case when an implementation has detected an Over-Temperature Condition Detected for Processor.

May also be shown as 806f01070301ffff or 0x806f01070301ffff

Severity

Error

Serviceable

Yes

Automatically notify support

No

Alert Category

Critical - Temperature

SNMP Trap ID

0

CIM Information

Prefix: PLAT ID: 0036

User Response

1. Make sure that the fans are operating. There are no obstructions to the airflow (front and rear of the server), the air baffles are in place and correctly installed, and the server cover is installed and completely closed.
2. Make sure that the heat sink for microprocessor n is installed correctly.
3. (Trained technician only) Replace microprocessor n. (n = microprocessor number)

- **806f0108-0a01ffff : [PowerSupplyElementName] has Failed. (Power Supply 1)**

This message is for the use case when an implementation has detected a Power Supply has failed.

May also be shown as 806f01080a01ffff or 0x806f01080a01ffff

Severity

Error

Serviceable

Yes

Automatically notify support

Yes

Alert Category

Critical - Power

SNMP Trap ID

4

CIM Information

Prefix: PLAT ID: 0086

User Response

1. Reseat power supply n.
2. If the power-on LED is not lit and the power-supply error LED is lit, replace power supply n.
3. If both the power-on LED and the power-supply error LED are not lit, see Power problems for more information. (n = power supply number)

- **806f0108-0a02ffff : [PowerSupplyElementName] has Failed. (Power Supply 2)**

This message is for the use case when an implementation has detected a Power Supply has failed.

May also be shown as 806f01080a02ffff or 0x806f01080a02ffff

Severity

Error

Serviceable

Yes

Automatically notify support

Yes

Alert Category

Critical - Power

SNMP Trap ID

4

CIM Information

Prefix: PLAT **ID:** 0086

User Response

1. Reseat power supply n.
2. If the power-on LED is not lit and the power-supply error LED is lit, replace power supply n.
3. If both the power-on LED and the power-supply error LED are not lit, see Power problems for more information. (n = power supply number)

- **806f0109-1301ffff : [PowerSupplyElementName] has been Power Cycled. (Host Power)**

This message is for the use case when an implementation has detected a Power Unit that has been power cycled.

May also be shown as 806f01091301ffff or 0x806f01091301ffff

Severity

Info

Serviceable

No

Automatically notify support

No

Alert Category

System - Other

SNMP Trap ID**CIM Information**

Prefix: PLAT **ID:** 0108

User Response

No action; information only.

- **806f010c-2001ffff : Uncorrectable error detected for [PhysicalMemoryElementName] on Subsystem [MemoryElementName]. (DIMM 1)**

This message is for the use case when an implementation has detected a Memory uncorrectable error.

May also be shown as 806f010c2001ffff or 0x806f010c2001ffff

Severity

Error

Serviceable

Yes

Automatically notify support

Yes

Alert Category

Critical - Memory

SNMP Trap ID

41

CIM Information

Prefix: PLAT ID: 0138

User Response

Note: Each time you install or remove a DIMM, you must disconnect the server from the power source; then, wait 10 seconds before restarting the server.

1. Refer to TIP H212293 for minimum code level.
2. Check the Lenovo support website for an applicable retain tip or firmware update that applies to this memory error.
3. Swap the affected DIMMs (as indicated by the error LEDs on the system board or the event logs) to a different memory channel or microprocessor.
4. If the problem follows the DIMM, replace the failing DIMM.
5. (Trained technician only) If the problem occurs on the same DIMM connector, check the DIMM connector. If the connector contains any foreign material or is damaged, replace the system board.
6. (Trained technician only) Remove the affected microprocessor and check the microprocessor socket pins for any damaged pins. If a damage is found, replace the system board.
7. (Trained technician only) Replace the affected microprocessor.
8. Manually re-enable all affected DIMMs if the server firmware version is older than UEFI v1.10. If the server firmware version is UEFI v1.10 or newer, disconnect and reconnect the server to the power source and restart the server.
9. (Trained Service technician only) Replace the affected microprocessor.

- **806f010c-2002ffff : Uncorrectable error detected for [PhysicalMemoryElementName] on Subsystem [MemoryElementName]. (DIMM 2)**

This message is for the use case when an implementation has detected a Memory uncorrectable error.

May also be shown as 806f010c2002ffff or 0x806f010c2002ffff

Severity

Error

Serviceable

Yes

Automatically notify support

Yes

Alert Category

Critical - Memory

SNMP Trap ID

41

CIM Information**Prefix:** PLAT **ID:** 0138**User Response**

Note: Each time you install or remove a DIMM, you must disconnect the server from the power source; then, wait 10 seconds before restarting the server.

1. Refer to TIP H212293 for minimum code level.
2. Check the Lenovo support website for an applicable retain tip or firmware update that applies to this memory error.
3. Swap the affected DIMMs (as indicated by the error LEDs on the system board or the event logs) to a different memory channel or microprocessor.
4. If the problem follows the DIMM, replace the failing DIMM.
5. (Trained technician only) If the problem occurs on the same DIMM connector, check the DIMM connector. If the connector contains any foreign material or is damaged, replace the system board.
6. (Trained technician only) Remove the affected microprocessor and check the microprocessor socket pins for any damaged pins. If a damage is found, replace the system board.
7. (Trained technician only) Replace the affected microprocessor.
8. Manually re-enable all affected DIMMs if the server firmware version is older than UEFI v1.10. If the server firmware version is UEFI v1.10 or newer, disconnect and reconnect the server to the power source and restart the server.
9. (Trained Service technician only) Replace the affected microprocessor.

- **806f010c-2003ffff : Uncorrectable error detected for [PhysicalMemoryElementName] on Subsystem [MemoryElementName]. (DIMM 3)**

This message is for the use case when an implementation has detected a Memory uncorrectable error.

May also be shown as 806f010c2003ffff or 0x806f010c2003ffff

Severity

Error

Serviceable

Yes

Automatically notify support

Yes

Alert Category

Critical - Memory

SNMP Trap ID

41

CIM Information**Prefix:** PLAT ID: 0138**User Response**

Note: Each time you install or remove a DIMM, you must disconnect the server from the power source; then, wait 10 seconds before restarting the server.

1. Refer to TIP H212293 for minimum code level.
2. Check the Lenovo support website for an applicable retain tip or firmware update that applies to this memory error.
3. Swap the affected DIMMs (as indicated by the error LEDs on the system board or the event logs) to a different memory channel or microprocessor.
4. If the problem follows the DIMM, replace the failing DIMM.
5. (Trained technician only) If the problem occurs on the same DIMM connector, check the DIMM connector. If the connector contains any foreign material or is damaged, replace the system board.
6. (Trained technician only) Remove the affected microprocessor and check the microprocessor socket pins for any damaged pins. If a damage is found, replace the system board.
7. (Trained technician only) Replace the affected microprocessor.
8. Manually re-enable all affected DIMMs if the server firmware version is older than UEFI v1.10. If the server firmware version is UEFI v1.10 or newer, disconnect and reconnect the server to the power source and restart the server.
9. (Trained Service technician only) Replace the affected microprocessor.

- **806f010c-2004ffff : Uncorrectable error detected for [PhysicalMemoryElementName] on Subsystem [MemoryElementName]. (DIMM 4)**

This message is for the use case when an implementation has detected a Memory uncorrectable error.

May also be shown as 806f010c2004ffff or 0x806f010c2004ffff

Severity

Error

Serviceable

Yes

Automatically notify support

Yes

Alert Category

Critical - Memory

SNMP Trap ID

41

CIM Information**Prefix:** PLAT ID: 0138

User Response

Note: Each time you install or remove a DIMM, you must disconnect the server from the power source; then, wait 10 seconds before restarting the server.

1. Refer to TIP H212293 for minimum code level.
2. Check the Lenovo support website for an applicable retain tip or firmware update that applies to this memory error.
3. Swap the affected DIMMs (as indicated by the error LEDs on the system board or the event logs) to a different memory channel or microprocessor.
4. If the problem follows the DIMM, replace the failing DIMM.
5. (Trained technician only) If the problem occurs on the same DIMM connector, check the DIMM connector. If the connector contains any foreign material or is damaged, replace the system board.
6. (Trained technician only) Remove the affected microprocessor and check the microprocessor socket pins for any damaged pins. If a damage is found, replace the system board.
7. (Trained technician only) Replace the affected microprocessor.
8. Manually re-enable all affected DIMMs if the server firmware version is older than UEFI v1.10. If the server firmware version is UEFI v1.10 or newer, disconnect and reconnect the server to the power source and restart the server.
9. (Trained Service technician only) Replace the affected microprocessor.

- **806f010c-2581ffff : Uncorrectable error detected for [PhysicalMemoryElementName] on Subsystem [MemoryElementName]. (All DIMMS)**

This message is for the use case when an implementation has detected a Memory uncorrectable error.

May also be shown as 806f010c2581ffff or 0x806f010c2581ffff

Severity

Error

Serviceable

Yes

Automatically notify support

Yes

Alert Category

Critical - Memory

SNMP Trap ID

41

CIM Information

Prefix: PLAT ID: 0138

User Response

Note: Each time you install or remove a DIMM, you must disconnect the server from the power source; then, wait 10 seconds before restarting the server.

1. Refer to TIP H212293 for minimum code level.
2. Check the Lenovo support website for an applicable retain tip or firmware update that applies to this memory error.

3. Swap the affected DIMMs (as indicated by the error LEDs on the system board or the event logs) to a different memory channel or microprocessor.
4. If the problem follows the DIMM, replace the failing DIMM.
5. (Trained technician only) If the problem occurs on the same DIMM connector, check the DIMM connector. If the connector contains any foreign material or is damaged, replace the system board.
6. (Trained technician only) Remove the affected microprocessor and check the microprocessor socket pins for any damaged pins. If a damage is found, replace the system board.
7. (Trained technician only) Replace the affected microprocessor.
8. Manually re-enable all affected DIMMs if the server firmware version is older than UEFI v1.10. If the server firmware version is UEFI v1.10 or newer, disconnect and reconnect the server to the power source and restart the server.
9. (Trained Service technician only) Replace the affected microprocessor.

One of the DIMMs :

- **806f010d-0400ffff : The Drive [StorageVolumeElementName] has been disabled due to a detected fault. (Drive 0)**

This message is for the use case when an implementation has detected a Drive was Disabled due to fault.

May also be shown as 806f010d0400ffff or 0x806f010d0400ffff

Severity

Error

Serviceable

Yes

Automatically notify support

Yes

Alert Category

Critical - Hard Disk drive

SNMP Trap ID

5

CIM Information

Prefix: PLAT **ID:** 0164

User Response

1. Run the hard disk drive diagnostic test on drive n.
2. Reseat the following components: a. Hard disk drive (wait 1 minute or more before reinstalling the drive) b. Cable from the system board to the backplane
3. Replace the following components one at a time, in the order shown, restarting the server each time: a. Hard disk drive b. Cable from the system board to the backplane c. Hard disk drive backplane (n = hard disk drive number)

- **806f010d-0401ffff : The Drive [StorageVolumeElementName] has been disabled due to a detected fault. (Drive 1)**

This message is for the use case when an implementation has detected a Drive was Disabled due to fault.

May also be shown as 806f010d0401ffff or 0x806f010d0401ffff

Severity

Error

Serviceable

Yes

Automatically notify support

Yes

Alert Category

Critical - Hard Disk drive

SNMP Trap ID

5

CIM Information

Prefix: PLAT **ID:** 0164

User Response

1. Run the hard disk drive diagnostic test on drive n.
2. Reseat the following components: a. Hard disk drive (wait 1 minute or more before reinstalling the drive) b. Cable from the system board to the backplane
3. Replace the following components one at a time, in the order shown, restarting the server each time: a. Hard disk drive b. Cable from the system board to the backplane c. Hard disk drive backplane (n = hard disk drive number)

- **806f010d-0402ffff : The Drive [StorageVolumeElementName] has been disabled due to a detected fault. (Drive 2)**

This message is for the use case when an implementation has detected a Drive was Disabled due to fault.

May also be shown as 806f010d0402ffff or 0x806f010d0402ffff

Severity

Error

Serviceable

Yes

Automatically notify support

Yes

Alert Category

Critical - Hard Disk drive

SNMP Trap ID

5

CIM Information

Prefix: PLAT **ID:** 0164

User Response

1. Run the hard disk drive diagnostic test on drive n.
2. Reseat the following components: a. Hard disk drive (wait 1 minute or more before reinstalling the drive) b. Cable from the system board to the backplane
3. Replace the following components one at a time, in the order shown, restarting the server each time: a. Hard disk drive b. Cable from the system board to the backplane c. Hard disk drive backplane (n = hard disk drive number)

- **806f010d-0403ffff : The Drive [StorageVolumeElementName] has been disabled due to a detected fault. (Drive 3)**

This message is for the use case when an implementation has detected a Drive was Disabled due to fault.

May also be shown as 806f010d0403ffff or 0x806f010d0403ffff

Severity

Error

Serviceable

Yes

Automatically notify support

Yes

Alert Category

Critical - Hard Disk drive

SNMP Trap ID

5

CIM Information

Prefix: PLAT ID: 0164

User Response

1. Run the hard disk drive diagnostic test on drive n.
2. Reseat the following components: a. Hard disk drive (wait 1 minute or more before reinstalling the drive) b. Cable from the system board to the backplane
3. Replace the following components one at a time, in the order shown, restarting the server each time: a. Hard disk drive b. Cable from the system board to the backplane c. Hard disk drive backplane (n = hard disk drive number)

- **806f010d-0404ffff : The Drive [StorageVolumeElementName] has been disabled due to a detected fault. (Drive 4)**

This message is for the use case when an implementation has detected a Drive was Disabled due to fault.

May also be shown as 806f010d0404ffff or 0x806f010d0404ffff

Severity

Error

Serviceable

Yes

Automatically notify support

Yes

Alert Category

Critical - Hard Disk drive

SNMP Trap ID

5

CIM Information

Prefix: PLAT **ID:** 0164

User Response

1. Run the hard disk drive diagnostic test on drive n.
2. Reseat the following components: a. Hard disk drive (wait 1 minute or more before reinstalling the drive) b. Cable from the system board to the backplane
3. Replace the following components one at a time, in the order shown, restarting the server each time: a. Hard disk drive b. Cable from the system board to the backplane c. Hard disk drive backplane (n = hard disk drive number)

- **806f010d-0405ffff : The Drive [StorageVolumeElementName] has been disabled due to a detected fault. (Drive 5)**

This message is for the use case when an implementation has detected a Drive was Disabled due to fault.

May also be shown as 806f010d0405ffff or 0x806f010d0405ffff

Severity

Error

Serviceable

Yes

Automatically notify support

Yes

Alert Category

Critical - Hard Disk drive

SNMP Trap ID

5

CIM Information

Prefix: PLAT **ID:** 0164

User Response

1. Run the hard disk drive diagnostic test on drive n.
2. Reseat the following components: a. Hard disk drive (wait 1 minute or more before reinstalling the drive) b. Cable from the system board to the backplane

3. Replace the following components one at a time, in the order shown, restarting the server each time: a. Hard disk drive b. Cable from the system board to the backplane c. Hard disk drive backplane (n = hard disk drive number)

- **806f010d-0406ffff : The Drive [StorageVolumeElementName] has been disabled due to a detected fault. (Drive 6)**

This message is for the use case when an implementation has detected a Drive was Disabled due to fault.

May also be shown as 806f010d0406ffff or 0x806f010d0406ffff

Severity

Error

Serviceable

Yes

Automatically notify support

Yes

Alert Category

Critical - Hard Disk drive

SNMP Trap ID

5

CIM Information

Prefix: PLAT **ID:** 0164

User Response

1. Run the hard disk drive diagnostic test on drive n.
2. Reseat the following components: a. Hard disk drive (wait 1 minute or more before reinstalling the drive) b. Cable from the system board to the backplane
3. Replace the following components one at a time, in the order shown, restarting the server each time: a. Hard disk drive b. Cable from the system board to the backplane c. Hard disk drive backplane (n = hard disk drive number)

- **806f010d-0407ffff : The Drive [StorageVolumeElementName] has been disabled due to a detected fault. (Drive 7)**

This message is for the use case when an implementation has detected a Drive was Disabled due to fault.

May also be shown as 806f010d0407ffff or 0x806f010d0407ffff

Severity

Error

Serviceable

Yes

Automatically notify support

Yes

Alert Category

Critical - Hard Disk drive

SNMP Trap ID

5

CIM Information

Prefix: PLAT ID: 0164

User Response

1. Run the hard disk drive diagnostic test on drive n.
 2. Reseat the following components: a. Hard disk drive (wait 1 minute or more before reinstalling the drive) b. Cable from the system board to the backplane
 3. Replace the following components one at a time, in the order shown, restarting the server each time: a. Hard disk drive b. Cable from the system board to the backplane c. Hard disk drive backplane (n = hard disk drive number)
- **806f010d-0410ffff : The Drive [StorageVolumeElementName] has been disabled due to a detected fault. (Ext Drive)**

This message is for the use case when an implementation has detected a Drive was Disabled due to fault.

May also be shown as 806f010d0410ffff or 0x806f010d0410ffff

Severity

Error

Serviceable

Yes

Automatically notify support

Yes

Alert Category

Critical - Hard Disk drive

SNMP Trap ID

5

CIM Information

Prefix: PLAT ID: 0164

User Response

1. Run the hard disk drive diagnostic test on drive n.
2. Reseat the following components: a. Hard disk drive (wait 1 minute or more before reinstalling the drive) b. Cable from the system board to the backplane
3. Replace the following components one at a time, in the order shown, restarting the server each time: a. Hard disk drive b. Cable from the system board to the backplane c. Hard disk drive backplane (n = hard disk drive number)

- **806f010f-2201ffff : The System [ComputerSystemElementName] encountered a firmware hang. (Firmware Error)**

This message is for the use case when an implementation has detected a System Firmware Hang.

May also be shown as 806f010f2201ffff or 0x806f010f2201ffff

Severity

Error

Serviceable

Yes

Automatically notify support

No

Alert Category

System - Boot failure

SNMP Trap ID

25

CIM Information

Prefix: PLAT ID: 0186

User Response

1. Make sure the server meets the minimum configuration to start (see Power-supply LEDs).
2. Update the server firmware on the primary page. Important: Some cluster solutions require specific code levels or coordinated code updates. If the device is part of a cluster solution, verify that the latest level of code is supported for the cluster solution before you update the code.
3. (Trained technician only) Replace the system board.

- **806f0123-2101ffff : Reboot of system [ComputerSystemElementName] initiated by [WatchdogElementName]. (IPMI Watchdog)**

This message is for the use case when an implementation has detected a Reboot by a Watchdog occurred.

May also be shown as 806f01232101ffff or 0x806f01232101ffff

Severity

Info

Serviceable

No

Automatically notify support

No

Alert Category

System - Other

SNMP Trap ID

CIM Information

Prefix: PLAT ID: 0370

User Response

No action; information only.

- **806f0125-1001ffff : [ManagedElementName] detected as absent. (PCI Riser 1)**

This message is for the use case when an implementation has detected a Managed Element is Absent.

May also be shown as 806f01251001ffff or 0x806f01251001ffff

Severity

Info

Serviceable

No

Automatically notify support

No

Alert Category

System - Other

SNMP Trap ID

CIM Information

Prefix: PLAT ID: 0392

User Response

If there is no GPU/storage tray installed in the system, then the log event is a normal condition. If there is a GPU/storage tray installed in the system, then check the following two portions:

1. PDB (Power Distribution Board) cable is correctly connected from riser card to PDB.
2. Replace another PDB cable.

- **806f0207-0301ffff : [ProcessorElementName] has Failed with FRB1/BIST condition. (CPU 1)**

This message is for the use case when an implementation has detected a Processor Failed - FRB1/BIST condition.

May also be shown as 806f02070301ffff or 0x806f02070301ffff

Severity

Error

Serviceable

Yes

Automatically notify support

Yes

Alert Category

Critical - CPU

SNMP Trap ID

CIM Information**Prefix:** PLAT ID: 0044**User Response**

1. Make sure that the latest levels of firmware and device drivers are installed for all adapters and standard devices, such as Ethernet, SCSI, and SAS. Important: Some cluster solutions require specific code levels or coordinated code updates. If the device is part of a cluster solution, verify that the latest level of code is supported for the cluster solution before you update the code.
 2. Update the firmware (UEFI and IMM) to the latest level (Updating the firmware).
 3. Run the DSA program.
 4. Reseat the adapter.
 5. Replace the adapter.
 6. (Trained technician only) Replace microprocessor n.
 7. (Trained technician only) Replace the system board. (n = microprocessor number)
- **806f020d-0400ffff : Failure Predicted on drive [StorageVolumeElementName] for array [ComputerSystemElementName]. (Drive 0)**

This message is for the use case when an implementation has detected an Array Failure is Predicted.

May also be shown as 806f020d0400ffff or 0x806f020d0400ffff

Severity

Warning

Serviceable

Yes

Automatically notify support

Yes

Alert Category

System - Predicted Failure

SNMP Trap ID

27

CIM Information**Prefix:** PLAT ID: 0168**User Response**

1. Run the hard disk drive diagnostic test on drive n.
2. Reseat the following components: a. Hard disk drive (wait 1 minute or more before reinstalling the drive) b. Cable from the system board to the backplane
3. Replace the following components one at a time, in the order shown, restarting the server each time: a. Hard disk drive b. Cable from the system board to the backplane c. Hard disk drive backplane (n = hard disk drive number)

- **806f020d-0401ffff : Failure Predicted on drive [StorageVolumeElementName] for array [ComputerSystemElementName]. (Drive 1)**

This message is for the use case when an implementation has detected an Array Failure is Predicted.

May also be shown as 806f020d0401ffff or 0x806f020d0401ffff

Severity

Warning

Serviceable

Yes

Automatically notify support

Yes

Alert Category

System - Predicted Failure

SNMP Trap ID

27

CIM Information

Prefix: PLAT ID: 0168

User Response

1. Run the hard disk drive diagnostic test on drive n.
2. Reseat the following components: a. Hard disk drive (wait 1 minute or more before reinstalling the drive) b. Cable from the system board to the backplane
3. Replace the following components one at a time, in the order shown, restarting the server each time: a. Hard disk drive b. Cable from the system board to the backplane c. Hard disk drive backplane (n = hard disk drive number)

- **806f020d-0402ffff : Failure Predicted on drive [StorageVolumeElementName] for array [ComputerSystemElementName]. (Drive 2)**

This message is for the use case when an implementation has detected an Array Failure is Predicted.

May also be shown as 806f020d0402ffff or 0x806f020d0402ffff

Severity

Warning

Serviceable

Yes

Automatically notify support

Yes

Alert Category

System - Predicted Failure

SNMP Trap ID

27

CIM Information

Prefix: PLAT ID: 0168

User Response

1. Run the hard disk drive diagnostic test on drive n.
2. Reseat the following components: a. Hard disk drive (wait 1 minute or more before reinstalling the drive) b. Cable from the system board to the backplane
3. Replace the following components one at a time, in the order shown, restarting the server each time: a. Hard disk drive b. Cable from the system board to the backplane c. Hard disk drive backplane (n = hard disk drive number)

- **806f020d-0403ffff : Failure Predicted on drive [StorageVolumeElementName] for array [ComputerSystemElementName]. (Drive 3)**

This message is for the use case when an implementation has detected an Array Failure is Predicted.

May also be shown as 806f020d0403ffff or 0x806f020d0403ffff

Severity

Warning

Serviceable

Yes

Automatically notify support

Yes

Alert Category

System - Predicted Failure

SNMP Trap ID

27

CIM Information

Prefix: PLAT ID: 0168

User Response

1. Run the hard disk drive diagnostic test on drive n.
2. Reseat the following components: a. Hard disk drive (wait 1 minute or more before reinstalling the drive) b. Cable from the system board to the backplane
3. Replace the following components one at a time, in the order shown, restarting the server each time: a. Hard disk drive b. Cable from the system board to the backplane c. Hard disk drive backplane (n = hard disk drive number)

- **806f020d-0404ffff : Failure Predicted on drive [StorageVolumeElementName] for array [ComputerSystemElementName]. (Drive 4)**

This message is for the use case when an implementation has detected an Array Failure is Predicted.

May also be shown as 806f020d0404ffff or 0x806f020d0404ffff

Severity

Warning

Serviceable

Yes

Automatically notify support

Yes

Alert Category

System - Predicted Failure

SNMP Trap ID

27

CIM Information

Prefix: PLAT **ID:** 0168

User Response

1. Run the hard disk drive diagnostic test on drive n.
2. Reseat the following components: a. Hard disk drive (wait 1 minute or more before reinstalling the drive) b. Cable from the system board to the backplane
3. Replace the following components one at a time, in the order shown, restarting the server each time: a. Hard disk drive b. Cable from the system board to the backplane c. Hard disk drive backplane (n = hard disk drive number)

- **806f020d-0405ffff : Failure Predicted on drive [StorageVolumeElementName] for array [ComputerSystemElementName]. (Drive 5)**

This message is for the use case when an implementation has detected an Array Failure is Predicted.

May also be shown as 806f020d0405ffff or 0x806f020d0405ffff

Severity

Warning

Serviceable

Yes

Automatically notify support

Yes

Alert Category

System - Predicted Failure

SNMP Trap ID

27

CIM Information

Prefix: PLAT **ID:** 0168

User Response

1. Run the hard disk drive diagnostic test on drive n.

2. Reseat the following components: a. Hard disk drive (wait 1 minute or more before reinstalling the drive) b. Cable from the system board to the backplane
3. Replace the following components one at a time, in the order shown, restarting the server each time: a. Hard disk drive b. Cable from the system board to the backplane c. Hard disk drive backplane (n = hard disk drive number)

- **806f020d-0406ffff : Failure Predicted on drive [StorageVolumeElementName] for array [ComputerSystemElementName]. (Drive 6)**

This message is for the use case when an implementation has detected an Array Failure is Predicted.

May also be shown as 806f020d0406ffff or 0x806f020d0406ffff

Severity

Warning

Serviceable

Yes

Automatically notify support

Yes

Alert Category

System - Predicted Failure

SNMP Trap ID

27

CIM Information

Prefix: PLAT ID: 0168

User Response

1. Run the hard disk drive diagnostic test on drive n.
2. Reseat the following components: a. Hard disk drive (wait 1 minute or more before reinstalling the drive) b. Cable from the system board to the backplane
3. Replace the following components one at a time, in the order shown, restarting the server each time: a. Hard disk drive b. Cable from the system board to the backplane c. Hard disk drive backplane (n = hard disk drive number)

- **806f020d-0407ffff : Failure Predicted on drive [StorageVolumeElementName] for array [ComputerSystemElementName]. (Drive 7)**

This message is for the use case when an implementation has detected an Array Failure is Predicted.

May also be shown as 806f020d0407ffff or 0x806f020d0407ffff

Severity

Warning

Serviceable

Yes

Automatically notify support

Yes

Alert Category

System - Predicted Failure

SNMP Trap ID

27

CIM Information

Prefix: PLAT ID: 0168

User Response

1. Run the hard disk drive diagnostic test on drive n.
2. Reseat the following components: a. Hard disk drive (wait 1 minute or more before reinstalling the drive) b. Cable from the system board to the backplane
3. Replace the following components one at a time, in the order shown, restarting the server each time: a. Hard disk drive b. Cable from the system board to the backplane c. Hard disk drive backplane (n = hard disk drive number)

- **806f020d-0410ffff : Failure Predicted on drive [StorageVolumeElementName] for array [ComputerSystemElementName]. (Ext Drive)**

This message is for the use case when an implementation has detected an Array Failure is Predicted.

May also be shown as 806f020d0410ffff or 0x806f020d0410ffff

Severity

Warning

Serviceable

Yes

Automatically notify support

Yes

Alert Category

System - Predicted Failure

SNMP Trap ID

27

CIM Information

Prefix: PLAT ID: 0168

User Response

1. Run the hard disk drive diagnostic test on drive n.
2. Reseat the following components: a. Hard disk drive (wait 1 minute or more before reinstalling the drive) b. Cable from the system board to the backplane
3. Replace the following components one at a time, in the order shown, restarting the server each time: a. Hard disk drive b. Cable from the system board to the backplane c. Hard disk drive backplane (n = hard disk drive number)

- **806f0223-2101ffff : Powering off system [ComputerSystemElementName] initiated by [WatchdogElementName]. (IPMI Watchdog)**

This message is for the use case when an implementation has detected a Poweroff by Watchdog has occurred.

May also be shown as 806f02232101ffff or 0x806f02232101ffff

Severity

Info

Serviceable

No

Automatically notify support

No

Alert Category

System - Other

SNMP Trap ID

CIM Information

Prefix: PLAT ID: 0372

User Response

No action; information only.

- **806f0308-0a01ffff : [PowerSupplyElementName] has lost input. (Power Supply 1)**

This message is for the use case when an implementation has detected a Power Supply that has input that has been lost.

May also be shown as 806f03080a01ffff or 0x806f03080a01ffff

Severity

Info

Serviceable

No

Automatically notify support

No

Alert Category

System - Other

SNMP Trap ID

CIM Information

Prefix: PLAT ID: 0100

User Response

1. Reconnect the power cords.

2. Check power supply n LED.
3. See Power-supply LEDs for more information. (n = power supply number)

- **806f0308-0a02ffff : [PowerSupplyElementName] has lost input. (Power Supply 2)**

This message is for the use case when an implementation has detected a Power Supply that has input that has been lost.

May also be shown as 806f03080a02ffff or 0x806f03080a02ffff

Severity

Info

Serviceable

No

Automatically notify support

No

Alert Category

System - Other

SNMP Trap ID

CIM Information

Prefix: PLAT ID: 0100

User Response

1. Reconnect the power cords.
2. Check power supply n LED.
3. See Power-supply LEDs for more information. (n = power supply number)

- **806f030c-2001ffff : Scrub Failure for [PhysicalMemoryElementName] on Subsystem [MemoryElementName]. (DIMM 1)**

This message is for the use case when an implementation has detected a Memory Scrub failure.

May also be shown as 806f030c2001ffff or 0x806f030c2001ffff

Severity

Error

Serviceable

Yes

Automatically notify support

No

Alert Category

Critical - Memory

SNMP Trap ID

CIM Information**Prefix:** PLAT ID: 0136**User Response**

Note: Each time you install or remove a DIMM, you must disconnect the server from the power source; then, wait 10 seconds before restarting the server.

1. Refer to TIP H212293 for minimum code level.
2. Check the Lenovo support website for an applicable retain tip or firmware update that applies to this memory error.
3. Make sure that the DIMMs are firmly seated and no foreign material is found in the DIMM connector. Then, retry with the same DIMM.
4. If the problem is related to a DIMM, replace the failing DIMM indicated by the error LEDs.
5. If the problem occurs on the same DIMM connector, swap the affected DIMMs (as indicated by the error LEDs on the system board or the event logs) to a different memory channel or microprocessor.
6. (Trained technician only) If the problem occurs on the same DIMM connector, check the DIMM connector. If the connector contains any foreign material or is damaged, replace the system board.
7. (Trained service technician only) Remove the affected microprocessor and check the microprocessor socket pins for any damaged pins. If a damage is found, replace the system board.
8. (Trained service technician only) If the problem is related to microprocessor socket pins, replace the system board.

- **806f030c-2002ffff : Scrub Failure for [PhysicalMemoryElementName] on Subsystem [MemoryElementName]. (DIMM 2)**

This message is for the use case when an implementation has detected a Memory Scrub failure.

May also be shown as 806f030c2002ffff or 0x806f030c2002ffff

Severity

Error

Serviceable

Yes

Automatically notify support

No

Alert Category

Critical - Memory

SNMP Trap ID

41

CIM Information**Prefix:** PLAT ID: 0136**User Response**

Note: Each time you install or remove a DIMM, you must disconnect the server from the power source; then, wait 10 seconds before restarting the server.

1. Refer to TIP H212293 for minimum code level.
2. Check the Lenovo support website for an applicable retain tip or firmware update that applies to this memory error.
3. Make sure that the DIMMs are firmly seated and no foreign material is found in the DIMM connector. Then, retry with the same DIMM.
4. If the problem is related to a DIMM, replace the failing DIMM indicated by the error LEDs.
5. If the problem occurs on the same DIMM connector, swap the affected DIMMs (as indicated by the error LEDs on the system board or the event logs) to a different memory channel or microprocessor.
6. (Trained technician only) If the problem occurs on the same DIMM connector, check the DIMM connector. If the connector contains any foreign material or is damaged, replace the system board.
7. (Trained service technician only) Remove the affected microprocessor and check the microprocessor socket pins for any damaged pins. If a damage is found, replace the system board.
8. (Trained service technician only) If the problem is related to microprocessor socket pins, replace the system board.

- **806f030c-2003ffff : Scrub Failure for [PhysicalMemoryElementName] on Subsystem [MemoryElementName]. (DIMM 3)**

This message is for the use case when an implementation has detected a Memory Scrub failure.

May also be shown as 806f030c2003ffff or 0x806f030c2003ffff

Severity

Error

Serviceable

Yes

Automatically notify support

No

Alert Category

Critical - Memory

SNMP Trap ID

41

CIM Information

Prefix: PLAT **ID:** 0136

User Response

Note: Each time you install or remove a DIMM, you must disconnect the server from the power source; then, wait 10 seconds before restarting the server.

1. Refer to TIP H212293 for minimum code level.
2. Check the Lenovo support website for an applicable retain tip or firmware update that applies to this memory error.
3. Make sure that the DIMMs are firmly seated and no foreign material is found in the DIMM connector. Then, retry with the same DIMM.
4. If the problem is related to a DIMM, replace the failing DIMM indicated by the error LEDs.

5. If the problem occurs on the same DIMM connector, swap the affected DIMMs (as indicated by the error LEDs on the system board or the event logs) to a different memory channel or microprocessor.
6. (Trained technician only) If the problem occurs on the same DIMM connector, check the DIMM connector. If the connector contains any foreign material or is damaged, replace the system board.
7. (Trained service technician only) Remove the affected microprocessor and check the microprocessor socket pins for any damaged pins. If a damage is found, replace the system board.
8. (Trained service technician only) If the problem is related to microprocessor socket pins, replace the system board.

- **806f030c-2004ffff : Scrub Failure for [PhysicalMemoryElementName] on Subsystem [MemoryElementName]. (DIMM 4)**

This message is for the use case when an implementation has detected a Memory Scrub failure.

May also be shown as 806f030c2004ffff or 0x806f030c2004ffff

Severity

Error

Serviceable

Yes

Automatically notify support

No

Alert Category

Critical - Memory

SNMP Trap ID

41

CIM Information

Prefix: PLAT **ID:** 0136

User Response

Note: Each time you install or remove a DIMM, you must disconnect the server from the power source; then, wait 10 seconds before restarting the server.

1. Refer to TIP H212293 for minimum code level.
2. Check the Lenovo support website for an applicable retain tip or firmware update that applies to this memory error.
3. Make sure that the DIMMs are firmly seated and no foreign material is found in the DIMM connector. Then, retry with the same DIMM.
4. If the problem is related to a DIMM, replace the failing DIMM indicated by the error LEDs.
5. If the problem occurs on the same DIMM connector, swap the affected DIMMs (as indicated by the error LEDs on the system board or the event logs) to a different memory channel or microprocessor.
6. (Trained technician only) If the problem occurs on the same DIMM connector, check the DIMM connector. If the connector contains any foreign material or is damaged, replace the system board.

7. (Trained service technician only) Remove the affected microprocessor and check the microprocessor socket pins for any damaged pins. If a damage is found, replace the system board.
8. (Trained service technician only) If the problem is related to microprocessor socket pins, replace the system board.

- **806f030c-2581ffff : Scrub Failure for [PhysicalMemoryElementName] on Subsystem [MemoryElementName]. (All DIMMS)**

This message is for the use case when an implementation has detected a Memory Scrub failure.

May also be shown as 806f030c2581ffff or 0x806f030c2581ffff

Severity

Error

Serviceable

Yes

Automatically notify support

No

Alert Category

Critical - Memory

SNMP Trap ID

41

CIM Information

Prefix: PLAT ID: 0136

User Response

Note: Each time you install or remove a DIMM, you must disconnect the server from the power source; then, wait 10 seconds before restarting the server.

1. Refer to TIP H212293 for minimum code level.
2. Check the Lenovo support website for an applicable retain tip or firmware update that applies to this memory error.
3. Make sure that the DIMMs are firmly seated and no foreign material is found in the DIMM connector. Then, retry with the same DIMM.
4. If the problem is related to a DIMM, replace the failing DIMM indicated by the error LEDs.
5. If the problem occurs on the same DIMM connector, swap the affected DIMMs (as indicated by the error LEDs on the system board or the event logs) to a different memory channel or microprocessor.
6. (Trained technician only) If the problem occurs on the same DIMM connector, check the DIMM connector. If the connector contains any foreign material or is damaged, replace the system board.
7. (Trained service technician only) Remove the affected microprocessor and check the microprocessor socket pins for any damaged pins. If a damage is found, replace the system board.
8. (Trained service technician only) If the problem is related to microprocessor socket pins, replace the system board.

One of the DIMMs :

- **806f030d-0400ffff : Hot Spare enabled for [ComputerSystemElementName]. (Drive 0)**
This message is for the use case when an implementation has detected a Hot Spare has been Enabled.
May also be shown as 806f030d0400ffff or 0x806f030d0400ffff

Severity

Info

Serviceable

No

Automatically notify support

No

Alert Category

System - Other

SNMP Trap ID

CIM Information

Prefix: PLAT ID: 0170

User Response

No action; information only.

- **806f030d-0401ffff : Hot Spare enabled for [ComputerSystemElementName]. (Drive 1)**
This message is for the use case when an implementation has detected a Hot Spare has been Enabled.
May also be shown as 806f030d0401ffff or 0x806f030d0401ffff

Severity

Info

Serviceable

No

Automatically notify support

No

Alert Category

System - Other

SNMP Trap ID

CIM Information

Prefix: PLAT ID: 0170

User Response

No action; information only.

- **806f030d-0402ffff : Hot Spare enabled for [ComputerSystemElementName]. (Drive 2)**

This message is for the use case when an implementation has detected a Hot Spare has been Enabled.
May also be shown as 806f030d0402ffff or 0x806f030d0402ffff

Severity

Info

Serviceable

No

Automatically notify support

No

Alert Category

System - Other

SNMP Trap ID

CIM Information

Prefix: PLAT ID: 0170

User Response

No action; information only.

- **806f030d-0403ffff : Hot Spare enabled for [ComputerSystemElementName]. (Drive 3)**

This message is for the use case when an implementation has detected a Hot Spare has been Enabled.
May also be shown as 806f030d0403ffff or 0x806f030d0403ffff

Severity

Info

Serviceable

No

Automatically notify support

No

Alert Category

System - Other

SNMP Trap ID

CIM Information

Prefix: PLAT ID: 0170

User Response

No action; information only.

- **806f030d-0404ffff : Hot Spare enabled for [ComputerSystemElementName]. (Drive 4)**

This message is for the use case when an implementation has detected a Hot Spare has been Enabled.
May also be shown as 806f030d0404ffff or 0x806f030d0404ffff

Severity

Info

Serviceable

No

Automatically notify support

No

Alert Category

System - Other

SNMP Trap ID**CIM Information**

Prefix: PLAT ID: 0170

User Response

No action; information only.

- **806f030d-0405ffff : Hot Spare enabled for [ComputerSystemElementName]. (Drive 5)**

This message is for the use case when an implementation has detected a Hot Spare has been Enabled.

May also be shown as 806f030d0405ffff or 0x806f030d0405ffff

Severity

Info

Serviceable

No

Automatically notify support

No

Alert Category

System - Other

SNMP Trap ID**CIM Information**

Prefix: PLAT ID: 0170

User Response

No action; information only.

- **806f030d-0406ffff : Hot Spare enabled for [ComputerSystemElementName]. (Drive 6)**

This message is for the use case when an implementation has detected a Hot Spare has been Enabled.

May also be shown as 806f030d0406ffff or 0x806f030d0406ffff

Severity

Info

Serviceable

No

Automatically notify support

No

Alert Category

System - Other

SNMP Trap ID

CIM Information

Prefix: PLAT ID: 0170

User Response

No action; information only.

- **806f030d-0407ffff : Hot Spare enabled for [ComputerSystemElementName]. (Drive 7)**

This message is for the use case when an implementation has detected a Hot Spare has been Enabled.

May also be shown as 806f030d0407ffff or 0x806f030d0407ffff

Severity

Info

Serviceable

No

Automatically notify support

No

Alert Category

System - Other

SNMP Trap ID

CIM Information

Prefix: PLAT ID: 0170

User Response

No action; information only.

- **806f030d-0410ffff : Hot Spare enabled for [ComputerSystemElementName]. (Ext Drive)**

This message is for the use case when an implementation has detected a Hot Spare has been Enabled.

May also be shown as 806f030d0410ffff or 0x806f030d0410ffff

Severity

Info

Serviceable

No

Automatically notify support

No

Alert Category

System - Other

SNMP Trap ID

CIM Information

Prefix: PLAT ID: 0170

User Response

No action; information only.

- **806f0313-1701ffff : A software NMI has occurred on system [ComputerSystemElementName]. (NMI State)**

This message is for the use case when an implementation has detected a Software NMI.

May also be shown as 806f03131701ffff or 0x806f03131701ffff

Severity

Error

Serviceable

Yes

Automatically notify support

No

Alert Category

Critical - Other

SNMP Trap ID

50

CIM Information

Prefix: PLAT ID: 0228

User Response

1. Check the device driver.
2. Reinstall the device driver.
3. Update all device drivers to the latest level.
4. Update the firmware (UEFI and IMM).

- **806f0323-2101ffff : Power cycle of system [ComputerSystemElementName] initiated by watchdog [WatchdogElementName]. (IPMI Watchdog)**

This message is for the use case when an implementation has detected a Power Cycle by Watchdog occurred.

May also be shown as 806f03232101ffff or 0x806f03232101ffff

Severity

Info

Serviceable

No

Automatically notify support

No

Alert Category

System - Other

SNMP Trap ID**CIM Information**

Prefix: PLAT ID: 0374

User Response

No action; information only.

- **806f040c-2001ffff : [PhysicalMemoryElementName] Disabled on Subsystem [MemoryElementName]. (DIMM 1)**

This message is for the use case when an implementation has detected that Memory has been Disabled.

May also be shown as 806f040c2001ffff or 0x806f040c2001ffff

Severity

Info

Serviceable

No

Automatically notify support

No

Alert Category

System - Other

SNMP Trap ID**CIM Information**

Prefix: PLAT ID: 0131

User Response

1. Make sure the DIMM is installed correctly.
2. If the DIMM was disabled because of a memory fault (memory uncorrectable error or memory logging limit reached), follow the suggested actions for that error event and restart the server.
3. Check the Lenovo support website for an applicable retain tip or firmware update that applies to this memory event. If no memory fault is recorded in the logs and no DIMM connector error LED is lit, you can re-enable the DIMM through the Setup utility.

- **806f040c-2002ffff : [PhysicalMemoryElementName] Disabled on Subsystem [MemoryElementName]. (DIMM 2)**

This message is for the use case when an implementation has detected that Memory has been Disabled.

May also be shown as 806f040c2002ffff or 0x806f040c2002ffff

Severity

Info

Serviceable

No

Automatically notify support

No

Alert Category

System - Other

SNMP Trap ID

CIM Information

Prefix: PLAT ID: 0131

User Response

1. Make sure the DIMM is installed correctly.
2. If the DIMM was disabled because of a memory fault (memory uncorrectable error or memory logging limit reached), follow the suggested actions for that error event and restart the server.
3. Check the Lenovo support website for an applicable retain tip or firmware update that applies to this memory event. If no memory fault is recorded in the logs and no DIMM connector error LED is lit, you can re-enable the DIMM through the Setup utility.

- **806f040c-2003ffff : [PhysicalMemoryElementName] Disabled on Subsystem [MemoryElementName]. (DIMM 3)**

This message is for the use case when an implementation has detected that Memory has been Disabled.

May also be shown as 806f040c2003ffff or 0x806f040c2003ffff

Severity

Info

Serviceable

No

Automatically notify support

No

Alert Category

System - Other

SNMP Trap ID

CIM Information

Prefix: PLAT ID: 0131

User Response

1. Make sure the DIMM is installed correctly.
2. If the DIMM was disabled because of a memory fault (memory uncorrectable error or memory logging limit reached), follow the suggested actions for that error event and restart the server.
3. Check the Lenovo support website for an applicable retain tip or firmware update that applies to this memory event. If no memory fault is recorded in the logs and no DIMM connector error LED is lit, you can re-enable the DIMM through the Setup utility.

- **806f040c-2004ffff : [PhysicalMemoryElementName] Disabled on Subsystem [MemoryElementName]. (DIMM 4)**

This message is for the use case when an implementation has detected that Memory has been Disabled.

May also be shown as 806f040c2004ffff or 0x806f040c2004ffff

Severity

Info

Serviceable

No

Automatically notify support

No

Alert Category

System - Other

SNMP Trap ID

CIM Information

Prefix: PLAT ID: 0131

User Response

1. Make sure the DIMM is installed correctly.
2. If the DIMM was disabled because of a memory fault (memory uncorrectable error or memory logging limit reached), follow the suggested actions for that error event and restart the server.
3. Check the Lenovo support website for an applicable retain tip or firmware update that applies to this memory event. If no memory fault is recorded in the logs and no DIMM connector error LED is lit, you can re-enable the DIMM through the Setup utility.

- **806f040c-2581ffff : [PhysicalMemoryElementName] Disabled on Subsystem [MemoryElementName]. (All DIMMS)**

This message is for the use case when an implementation has detected that Memory has been Disabled.

May also be shown as 806f040c2581ffff or 0x806f040c2581ffff

Severity

Info

Serviceable

No

Automatically notify support

No

Alert Category

System - Other

SNMP Trap ID**CIM Information****Prefix: PLAT ID:** 0131**User Response**

1. Make sure the DIMM is installed correctly.
2. If the DIMM was disabled because of a memory fault (memory uncorrectable error or memory logging limit reached), follow the suggested actions for that error event and restart the server.
3. Check the Lenovo support website for an applicable retain tip or firmware update that applies to this memory event. If no memory fault is recorded in the logs and no DIMM connector error LED is lit, you can re-enable the DIMM through the Setup utility.

One of the DIMMs :

- **806f0413-2582ffff : A PCI PERR has occurred on system [ComputerSystemElementName]. (PCIs)**

This message is for the use case when an implementation has detected a PCI PERR.

May also be shown as 806f04132582ffff or 0x806f04132582ffff

Severity

Error

Serviceable

Yes

Automatically notify support

No

Alert Category

Critical - Other

SNMP Trap ID

50

CIM Information**Prefix: PLAT ID:** 0232**User Response**

1. Check the PCI LED.

2. Reseat the affected adapters and riser cards.
3. Update the server firmware (UEFI and IMM) and adapter firmware. Important: Some cluster solutions require specific code levels or coordinated code updates. If the device is part of a cluster solution, verify that the latest level of code is supported for the cluster solution before you update the code.
4. Remove both adapters.
5. Replace the PCIe adapters.
6. Replace the riser card.

- **806f0507-0301ffff : [ProcessorElementName] has a Configuration Mismatch. (CPU 1)**

This message is for the use case when an implementation has detected a Processor Configuration Mismatch has occurred.

May also be shown as 806f05070301ffff or 0x806f05070301ffff

Severity

Error

Serviceable

Yes

Automatically notify support

No

Alert Category

Critical - CPU

SNMP Trap ID

40

CIM Information

Prefix: PLAT ID: 0062

User Response

1. Check the CPU LED. See more information about the CPU LED in Light path diagnostics.
2. Check for a server firmware update. Important: Some cluster solutions require specific code levels or coordinated code updates. If the device is part of a cluster solution, verify that the latest level of code is supported for the cluster solution before you update the code.
3. Make sure that the installed microprocessors are compatible with each other.
4. (Trained technician only) Reseat microprocessor n.
5. (Trained technician only) Replace microprocessor n. (n = microprocessor number)

- **806f050c-2001ffff : Memory Logging Limit Reached for [PhysicalMemoryElementName] on Subsystem [MemoryElementName]. (DIMM 1)**

This message is for the use case when an implementation has detected that the Memory Logging Limit has been Reached.

May also be shown as 806f050c2001ffff or 0x806f050c2001ffff

Severity

Warning

Serviceable

Yes

Automatically notify support

Yes

Alert Category

Warning - Memory

SNMP Trap ID

43

CIM Information

Prefix: PLAT ID: 0144

User Response

Note: Each time you install or remove a DIMM, you must disconnect the server from the power source; then, wait 10 seconds before restarting the server.

1. Refer to TIP H212293 for minimum code level.
2. Check the Lenovo support website for an applicable retain tip or firmware update that applies to this memory error.
3. Swap the affected DIMMs (as indicated by the error LEDs on the system board or the event logs) to a different memory channel or microprocessor.
4. If the error still occurs on the same DIMM, replace the affected DIMM.
5. (Trained technician only) If the problem occurs on the same DIMM connector, check the DIMM connector. If the connector contains any foreign material or is damaged, replace the system board.
6. (Trained technician only) Remove the affected microprocessor and check the microprocessor socket pins for any damaged pins. If a damage is found, replace the system board.
7. (Trained technician only) Replace the affected microprocessor.

- **806f050c-2002ffff : Memory Logging Limit Reached for [PhysicalMemoryElementName] on Subsystem [MemoryElementName]. (DIMM 2)**

This message is for the use case when an implementation has detected that the Memory Logging Limit has been Reached.

May also be shown as 806f050c2002ffff or 0x806f050c2002ffff

Severity

Warning

Serviceable

Yes

Automatically notify support

Yes

Alert Category

Warning - Memory

SNMP Trap ID

43

CIM Information**Prefix:** PLAT **ID:** 0144**User Response**

Note: Each time you install or remove a DIMM, you must disconnect the server from the power source; then, wait 10 seconds before restarting the server.

1. Refer to TIP H212293 for minimum code level.
2. Check the Lenovo support website for an applicable retain tip or firmware update that applies to this memory error.
3. Swap the affected DIMMs (as indicated by the error LEDs on the system board or the event logs) to a different memory channel or microprocessor.
4. If the error still occurs on the same DIMM, replace the affected DIMM.
5. (Trained technician only) If the problem occurs on the same DIMM connector, check the DIMM connector. If the connector contains any foreign material or is damaged, replace the system board.
6. (Trained technician only) Remove the affected microprocessor and check the microprocessor socket pins for any damaged pins. If a damage is found, replace the system board.
7. (Trained technician only) Replace the affected microprocessor.

- **806f050c-2003ffff : Memory Logging Limit Reached for [PhysicalMemoryElementName] on Subsystem [MemoryElementName]. (DIMM 3)**

This message is for the use case when an implementation has detected that the Memory Logging Limit has been Reached.

May also be shown as 806f050c2003ffff or 0x806f050c2003ffff

Severity

Warning

Serviceable

Yes

Automatically notify support

Yes

Alert Category

Warning - Memory

SNMP Trap ID

43

CIM Information**Prefix:** PLAT **ID:** 0144**User Response**

Note: Each time you install or remove a DIMM, you must disconnect the server from the power source; then, wait 10 seconds before restarting the server.

1. Refer to TIP H212293 for minimum code level.

2. Check the Lenovo support website for an applicable retain tip or firmware update that applies to this memory error.
3. Swap the affected DIMMs (as indicated by the error LEDs on the system board or the event logs) to a different memory channel or microprocessor.
4. If the error still occurs on the same DIMM, replace the affected DIMM.
5. (Trained technician only) If the problem occurs on the same DIMM connector, check the DIMM connector. If the connector contains any foreign material or is damaged, replace the system board.
6. (Trained technician only) Remove the affected microprocessor and check the microprocessor socket pins for any damaged pins. If a damage is found, replace the system board.
7. (Trained technician only) Replace the affected microprocessor.

- **806f050c-2004ffff : Memory Logging Limit Reached for [PhysicalMemoryElementName] on Subsystem [MemoryElementName]. (DIMM 4)**

This message is for the use case when an implementation has detected that the Memory Logging Limit has been Reached.

May also be shown as 806f050c2004ffff or 0x806f050c2004ffff

Severity

Warning

Serviceable

Yes

Automatically notify support

Yes

Alert Category

Warning - Memory

SNMP Trap ID

43

CIM Information

Prefix: PLAT **ID:** 0144

User Response

Note: Each time you install or remove a DIMM, you must disconnect the server from the power source; then, wait 10 seconds before restarting the server.

1. Refer to TIP H212293 for minimum code level.
2. Check the Lenovo support website for an applicable retain tip or firmware update that applies to this memory error.
3. Swap the affected DIMMs (as indicated by the error LEDs on the system board or the event logs) to a different memory channel or microprocessor.
4. If the error still occurs on the same DIMM, replace the affected DIMM.
5. (Trained technician only) If the problem occurs on the same DIMM connector, check the DIMM connector. If the connector contains any foreign material or is damaged, replace the system board.
6. (Trained technician only) Remove the affected microprocessor and check the microprocessor socket pins for any damaged pins. If a damage is found, replace the system board.

7. (Trained technician only) Replace the affected microprocessor.

- **806f050c-2581ffff : Memory Logging Limit Reached for [PhysicalMemoryElementName] on Subsystem [MemoryElementName]. (All DIMMS)**

This message is for the use case when an implementation has detected that the Memory Logging Limit has been Reached.

May also be shown as 806f050c2581ffff or 0x806f050c2581ffff

Severity

Warning

Serviceable

Yes

Automatically notify support

Yes

Alert Category

Warning - Memory

SNMP Trap ID

43

CIM Information

Prefix: PLAT **ID:** 0144

User Response

Note: Each time you install or remove a DIMM, you must disconnect the server from the power source; then, wait 10 seconds before restarting the server.

1. Refer to TIP H212293 for minimum code level.
2. Check the Lenovo support website for an applicable retain tip or firmware update that applies to this memory error.
3. Swap the affected DIMMs (as indicated by the error LEDs on the system board or the event logs) to a different memory channel or microprocessor.
4. If the error still occurs on the same DIMM, replace the affected DIMM.
5. (Trained technician only) If the problem occurs on the same DIMM connector, check the DIMM connector. If the connector contains any foreign material or is damaged, replace the system board.
6. (Trained technician only) Remove the affected microprocessor and check the microprocessor socket pins for any damaged pins. If a damage is found, replace the system board.
7. (Trained technician only) Replace the affected microprocessor.

One of the DIMMs :

- **806f050d-0400ffff : Array [ComputerSystemElementName] is in critical condition. (Drive 0)**

This message is for the use case when an implementation has detected that an Array is Critical.

May also be shown as 806f050d0400ffff or 0x806f050d0400ffff

Severity

Error

Serviceable

Yes

Automatically notify support

No

Alert Category

Critical - Hard Disk drive

SNMP Trap ID

5

CIM Information**Prefix: PLAT ID: 0174****User Response**

1. Make sure that the RAID adapter firmware and hard disk drive firmware are at the latest level.
2. Make sure that the SAS cable is connected correctly.
3. Replace the SAS cable.
4. Check backplane cable connection.
5. Replace the RAID adapter.
6. Replace the hard disk drive that is indicated by a lit status LED.

- **806f050d-0401ffff : Array [ComputerSystemElementName] is in critical condition. (Drive 1)**

This message is for the use case when an implementation has detected that an Array is Critical.

May also be shown as 806f050d0401ffff or 0x806f050d0401ffff

Severity

Error

Serviceable

Yes

Automatically notify support

No

Alert Category

Critical - Hard Disk drive

SNMP Trap ID

5

CIM Information**Prefix: PLAT ID: 0174****User Response**

1. Make sure that the RAID adapter firmware and hard disk drive firmware are at the latest level.
2. Make sure that the SAS cable is connected correctly.

3. Replace the SAS cable.
4. Check backplane cable connection.
5. Replace the RAID adapter.
6. Replace the hard disk drive that is indicated by a lit status LED.

- **806f050d-0402ffff : Array [ComputerSystemElementName] is in critical condition. (Drive 2)**

This message is for the use case when an implementation has detected that an Array is Critical.

May also be shown as 806f050d0402ffff or 0x806f050d0402ffff

Severity

Error

Serviceable

Yes

Automatically notify support

No

Alert Category

Critical - Hard Disk drive

SNMP Trap ID

5

CIM Information

Prefix: PLAT ID: 0174

User Response

1. Make sure that the RAID adapter firmware and hard disk drive firmware are at the latest level.
2. Make sure that the SAS cable is connected correctly.
3. Replace the SAS cable.
4. Check backplane cable connection.
5. Replace the RAID adapter.
6. Replace the hard disk drive that is indicated by a lit status LED.

- **806f050d-0403ffff : Array [ComputerSystemElementName] is in critical condition. (Drive 3)**

This message is for the use case when an implementation has detected that an Array is Critical.

May also be shown as 806f050d0403ffff or 0x806f050d0403ffff

Severity

Error

Serviceable

Yes

Automatically notify support

No

Alert Category

Critical - Hard Disk drive

SNMP Trap ID

5

CIM Information

Prefix: PLAT ID: 0174

User Response

1. Make sure that the RAID adapter firmware and hard disk drive firmware are at the latest level.
2. Make sure that the SAS cable is connected correctly.
3. Replace the SAS cable.
4. Check backplane cable connection.
5. Replace the RAID adapter.
6. Replace the hard disk drive that is indicated by a lit status LED.

• **806f050d-0404ffff : Array [ComputerSystemElementName] is in critical condition. (Drive 4)**

This message is for the use case when an implementation has detected that an Array is Critical.

May also be shown as 806f050d0404ffff or 0x806f050d0404ffff

Severity

Error

Serviceable

Yes

Automatically notify support

No

Alert Category

Critical - Hard Disk drive

SNMP Trap ID

5

CIM Information

Prefix: PLAT ID: 0174

User Response

1. Make sure that the RAID adapter firmware and hard disk drive firmware are at the latest level.
2. Make sure that the SAS cable is connected correctly.
3. Replace the SAS cable.
4. Check backplane cable connection.
5. Replace the RAID adapter.
6. Replace the hard disk drive that is indicated by a lit status LED.

- **806f050d-0405ffff : Array [ComputerSystemElementName] is in critical condition. (Drive 5)**

This message is for the use case when an implementation has detected that an Array is Critical.

May also be shown as 806f050d0405ffff or 0x806f050d0405ffff

Severity

Error

Serviceable

Yes

Automatically notify support

No

Alert Category

Critical - Hard Disk drive

SNMP Trap ID

5

CIM Information

Prefix: PLAT ID: 0174

User Response

1. Make sure that the RAID adapter firmware and hard disk drive firmware are at the latest level.
2. Make sure that the SAS cable is connected correctly.
3. Replace the SAS cable.
4. Check backplane cable connection.
5. Replace the RAID adapter.
6. Replace the hard disk drive that is indicated by a lit status LED.

- **806f050d-0406ffff : Array [ComputerSystemElementName] is in critical condition. (Drive 6)**

This message is for the use case when an implementation has detected that an Array is Critical.

May also be shown as 806f050d0406ffff or 0x806f050d0406ffff

Severity

Error

Serviceable

Yes

Automatically notify support

No

Alert Category

Critical - Hard Disk drive

SNMP Trap ID

5

CIM Information

Prefix: PLAT ID: 0174

User Response

1. Make sure that the RAID adapter firmware and hard disk drive firmware are at the latest level.
2. Make sure that the SAS cable is connected correctly.
3. Replace the SAS cable.
4. Check backplane cable connection.
5. Replace the RAID adapter.
6. Replace the hard disk drive that is indicated by a lit status LED.

- **806f050d-0407ffff : Array [ComputerSystemElementName] is in critical condition. (Drive 7)**

This message is for the use case when an implementation has detected that an Array is Critical.

May also be shown as 806f050d0407ffff or 0x806f050d0407ffff

Severity

Error

Serviceable

Yes

Automatically notify support

No

Alert Category

Critical - Hard Disk drive

SNMP Trap ID

5

CIM Information

Prefix: PLAT ID: 0174

User Response

1. Make sure that the RAID adapter firmware and hard disk drive firmware are at the latest level.
2. Make sure that the SAS cable is connected correctly.
3. Replace the SAS cable.
4. Check backplane cable connection.
5. Replace the RAID adapter.
6. Replace the hard disk drive that is indicated by a lit status LED.

- **806f050d-0410ffff : Array [ComputerSystemElementName] is in critical condition. (Ext Drive)**

This message is for the use case when an implementation has detected that an Array is Critical.

May also be shown as 806f050d0410ffff or 0x806f050d0410ffff

Severity

Error

Serviceable

Yes

Automatically notify support

No

Alert Category

Critical - Hard Disk drive

SNMP Trap ID

5

CIM Information

Prefix: PLAT ID: 0174

User Response

1. Make sure that the RAID adapter firmware and hard disk drive firmware are at the latest level.
2. Make sure that the SAS cable is connected correctly.
3. Replace the SAS cable.
4. Check backplane cable connection.
5. Replace the RAID adapter.
6. Replace the hard disk drive that is indicated by a lit status LED.

- **806f0513-2582ffff : A PCI SERR has occurred on system [ComputerSystemElementName]. (PCIs)**

This message is for the use case when an implementation has detected a PCI SERR.

May also be shown as 806f05132582ffff or 0x806f05132582ffff

Severity

Error

Serviceable

Yes

Automatically notify support

No

Alert Category

Critical - Other

SNMP Trap ID

50

CIM Information

Prefix: PLAT ID: 0234

User Response

1. Check the PCI LED.

2. Reseat the affected adapters and riser card.
3. Update the server firmware (UEFI and IMM) and adapter firmware. Important: Some cluster solutions require specific code levels or coordinated code updates. If the device is part of a cluster solution, verify that the latest level of code is supported for the cluster solution before you update the code.
4. Make sure that the adapter is supported. For a list of supported optional devices, see <http://www.lenovo.com/serverproven/>.
5. Remove both adapters.
6. Replace the PCIe adapters.
7. Replace the riser card.

- **806f052b-2101ffff : Invalid or Unsupported firmware or software was detected on system [ComputerSystemElementName]. (IMM2 FW Failover)**

This message is for the use case when an implementation has detected an Invalid/Unsupported Firmware/Software Version.

May also be shown as 806f052b2101ffff or 0x806f052b2101ffff

Severity

Error

Serviceable

Yes

Automatically notify support

No

Alert Category

Critical - Other

SNMP Trap ID

50

CIM Information

Prefix: PLAT ID: 0446

User Response

1. Make sure the server meets the minimum configuration to start (see Power-supply LEDs).
2. Recover the server firmware from the backup page by restarting the server.
3. Update the server firmware to the latest level (see Updating the firmware). Important: Some cluster solutions require specific code levels or coordinated code updates. If the device is part of a cluster solution, verify that the latest level of code is supported for the cluster solution before you update the code.
4. Remove components one at a time, restarting the server each time, to see if the problem goes away.
5. If the problem remains, (trained service technician) replace the system board.

- **806f0607-0301ffff : An SM BIOS Uncorrectable CPU complex error for [ProcessorElementName] has asserted. (CPU 1)**

This message is for the use case when an SM BIOS Uncorrectable CPU complex error has asserted.

May also be shown as 806f06070301ffff or 0x806f06070301ffff

Severity

Error

Serviceable

Yes

Automatically notify support

No

Alert Category

Critical - CPU

SNMP Trap ID

40

CIM Information

Prefix: PLAT ID: 0816

User Response

1. Make sure that the installed microprocessors are compatible with each other (see Installing a microprocessor and heat sink for information about microprocessor requirements).
2. Update the server firmware to the latest level (see Updating the firmware).
3. (Trained technician only) Replace the incompatible microprocessor.

- **806f060d-0400ffff : Array [ComputerSystemElementName] has failed. (Drive 0)**

This message is for the use case when an implementation has detected that an Array Failed.

May also be shown as 806f060d0400ffff or 0x806f060d0400ffff

Severity

Error

Serviceable

Yes

Automatically notify support

Yes

Alert Category

Critical - Hard Disk drive

SNMP Trap ID

5

CIM Information

Prefix: PLAT ID: 0176

User Response

1. Make sure that the RAID adapter firmware and hard disk drive firmware are at the latest level.
2. Make sure that the SAS cable is connected correctly.
3. Replace the SAS cable.
4. Replace the RAID adapter.
5. Replace the hard disk drive that is indicated by a lit status LED.

- **806f060d-0401ffff : Array [ComputerSystemElementName] has failed. (Drive 1)**

This message is for the use case when an implementation has detected that an Array Failed.

May also be shown as 806f060d0401ffff or 0x806f060d0401ffff

Severity

Error

Serviceable

Yes

Automatically notify support

Yes

Alert Category

Critical - Hard Disk drive

SNMP Trap ID

5

CIM Information

Prefix: PLAT **ID:** 0176

User Response

1. Make sure that the RAID adapter firmware and hard disk drive firmware are at the latest level.
2. Make sure that the SAS cable is connected correctly.
3. Replace the SAS cable.
4. Replace the RAID adapter.
5. Replace the hard disk drive that is indicated by a lit status LED.

- **806f060d-0402ffff : Array [ComputerSystemElementName] has failed. (Drive 2)**

This message is for the use case when an implementation has detected that an Array Failed.

May also be shown as 806f060d0402ffff or 0x806f060d0402ffff

Severity

Error

Serviceable

Yes

Automatically notify support

Yes

Alert Category

Critical - Hard Disk drive

SNMP Trap ID

5

CIM Information

Prefix: PLAT ID: 0176

User Response

1. Make sure that the RAID adapter firmware and hard disk drive firmware are at the latest level.
2. Make sure that the SAS cable is connected correctly.
3. Replace the SAS cable.
4. Replace the RAID adapter.
5. Replace the hard disk drive that is indicated by a lit status LED.

- **806f060d-0403ffff : Array [ComputerSystemElementName] has failed. (Drive 3)**

This message is for the use case when an implementation has detected that an Array Failed.

May also be shown as 806f060d0403ffff or 0x806f060d0403ffff

Severity

Error

Serviceable

Yes

Automatically notify support

Yes

Alert Category

Critical - Hard Disk drive

SNMP Trap ID

5

CIM Information

Prefix: PLAT ID: 0176

User Response

1. Make sure that the RAID adapter firmware and hard disk drive firmware are at the latest level.
2. Make sure that the SAS cable is connected correctly.
3. Replace the SAS cable.
4. Replace the RAID adapter.
5. Replace the hard disk drive that is indicated by a lit status LED.

- **806f060d-0404ffff : Array [ComputerSystemElementName] has failed. (Drive 4)**

This message is for the use case when an implementation has detected that an Array Failed.

May also be shown as 806f060d0404ffff or 0x806f060d0404ffff

Severity

Error

Serviceable

Yes

Automatically notify support

Yes

Alert Category

Critical - Hard Disk drive

SNMP Trap ID

5

CIM Information

Prefix: PLAT ID: 0176

User Response

1. Make sure that the RAID adapter firmware and hard disk drive firmware are at the latest level.
2. Make sure that the SAS cable is connected correctly.
3. Replace the SAS cable.
4. Replace the RAID adapter.
5. Replace the hard disk drive that is indicated by a lit status LED.

- **806f060d-0405ffff : Array [ComputerSystemElementName] has failed. (Drive 5)**

This message is for the use case when an implementation has detected that an Array Failed.

May also be shown as 806f060d0405ffff or 0x806f060d0405ffff

Severity

Error

Serviceable

Yes

Automatically notify support

Yes

Alert Category

Critical - Hard Disk drive

SNMP Trap ID

5

CIM Information

Prefix: PLAT ID: 0176

User Response

1. Make sure that the RAID adapter firmware and hard disk drive firmware are at the latest level.
2. Make sure that the SAS cable is connected correctly.
3. Replace the SAS cable.
4. Replace the RAID adapter.
5. Replace the hard disk drive that is indicated by a lit status LED.

- **806f060d-0406ffff : Array [ComputerSystemElementName] has failed. (Drive 6)**

This message is for the use case when an implementation has detected that an Array Failed.

May also be shown as 806f060d0406ffff or 0x806f060d0406ffff

Severity

Error

Serviceable

Yes

Automatically notify support

Yes

Alert Category

Critical - Hard Disk drive

SNMP Trap ID

5

CIM Information

Prefix: PLAT ID: 0176

User Response

1. Make sure that the RAID adapter firmware and hard disk drive firmware are at the latest level.
2. Make sure that the SAS cable is connected correctly.
3. Replace the SAS cable.
4. Replace the RAID adapter.
5. Replace the hard disk drive that is indicated by a lit status LED.

- **806f060d-0407ffff : Array [ComputerSystemElementName] has failed. (Drive 7)**

This message is for the use case when an implementation has detected that an Array Failed.

May also be shown as 806f060d0407ffff or 0x806f060d0407ffff

Severity

Error

Serviceable

Yes

Automatically notify support

Yes

Alert Category

Critical - Hard Disk drive

SNMP Trap ID

5

CIM Information

Prefix: PLAT ID: 0176

User Response

1. Make sure that the RAID adapter firmware and hard disk drive firmware are at the latest level.
2. Make sure that the SAS cable is connected correctly.
3. Replace the SAS cable.
4. Replace the RAID adapter.
5. Replace the hard disk drive that is indicated by a lit status LED.

• **806f060d-0410ffff : Array [ComputerSystemElementName] has failed. (Ext Drive)**

This message is for the use case when an implementation has detected that an Array Failed.

May also be shown as 806f060d0410ffff or 0x806f060d0410ffff

Severity

Error

Serviceable

Yes

Automatically notify support

Yes

Alert Category

Critical - Hard Disk drive

SNMP Trap ID

5

CIM Information

Prefix: PLAT ID: 0176

User Response

1. Make sure that the RAID adapter firmware and hard disk drive firmware are at the latest level.
2. Make sure that the SAS cable is connected correctly.
3. Replace the SAS cable.
4. Replace the RAID adapter.
5. Replace the hard disk drive that is indicated by a lit status LED.

- **806f070c-2001ffff : Configuration Error for [PhysicalMemoryElementName] on Subsystem [MemoryElementName]. (DIMM 1)**

This message is for the use case when an implementation has detected a Memory DIMM configuration error has been corrected.

May also be shown as 806f070c2001ffff or 0x806f070c2001ffff

Severity

Error

Serviceable

Yes

Automatically notify support

No

Alert Category

Critical - Memory

SNMP Trap ID

41

CIM Information

Prefix: PLAT ID: 0126

User Response

Make sure that DIMMs are installed in the correct sequence and have the same size, type, speed, and technology.

- **806f070c-2002ffff : Configuration Error for [PhysicalMemoryElementName] on Subsystem [MemoryElementName]. (DIMM 2)**

This message is for the use case when an implementation has detected a Memory DIMM configuration error has been corrected.

May also be shown as 806f070c2002ffff or 0x806f070c2002ffff

Severity

Error

Serviceable

Yes

Automatically notify support

No

Alert Category

Critical - Memory

SNMP Trap ID

41

CIM Information

Prefix: PLAT ID: 0126

User Response

Make sure that DIMMs are installed in the correct sequence and have the same size, type, speed, and technology.

- **806f070c-2003ffff : Configuration Error for [PhysicalMemoryElementName] on Subsystem [MemoryElementName]. (DIMM 3)**

This message is for the use case when an implementation has detected a Memory DIMM configuration error has been corrected.

May also be shown as 806f070c2003ffff or 0x806f070c2003ffff

Severity

Error

Serviceable

Yes

Automatically notify support

No

Alert Category

Critical - Memory

SNMP Trap ID

41

CIM Information

Prefix: PLAT ID: 0126

User Response

Make sure that DIMMs are installed in the correct sequence and have the same size, type, speed, and technology.

- **806f070c-2004ffff : Configuration Error for [PhysicalMemoryElementName] on Subsystem [MemoryElementName]. (DIMM 4)**

This message is for the use case when an implementation has detected a Memory DIMM configuration error has been corrected.

May also be shown as 806f070c2004ffff or 0x806f070c2004ffff

Severity

Error

Serviceable

Yes

Automatically notify support

No

Alert Category

Critical - Memory

SNMP Trap ID

41

CIM Information

Prefix: PLAT ID: 0126

User Response

Make sure that DIMMs are installed in the correct sequence and have the same size, type, speed, and technology.

- **806f070c-2581ffff : Configuration Error for [PhysicalMemoryElementName] on Subsystem [MemoryElementName]. (All DIMMS)**

This message is for the use case when an implementation has detected a Memory DIMM configuration error has been corrected.

May also be shown as 806f070c2581ffff or 0x806f070c2581ffff

Severity

Error

Serviceable

Yes

Automatically notify support

No

Alert Category

Critical - Memory

SNMP Trap ID

41

CIM Information

Prefix: PLAT ID: 0126

User Response

Make sure that DIMMs are installed in the correct sequence and have the same size, type, speed, and technology. One of the DIMMs :

- **806f070d-0400ffff : Rebuild in progress for Array in system [ComputerSystemElementName]. (Drive 0)**

This message is for the use case when an implementation has detected that an Array Rebuild is in Progress.

May also be shown as 806f070d0400ffff or 0x806f070d0400ffff

Severity

Info

Serviceable

No

Automatically notify support

No

Alert Category

System - Other

SNMP Trap ID**CIM Information**

Prefix: PLAT ID: 0178

User Response

No action; information only.

- **806f070d-0401ffff : Rebuild in progress for Array in system [ComputerSystemElementName]. (Drive 1)**

This message is for the use case when an implementation has detected that an Array Rebuild is in Progress.

May also be shown as 806f070d0401ffff or 0x806f070d0401ffff

Severity

Info

Serviceable

No

Automatically notify support

No

Alert Category

System - Other

SNMP Trap ID**CIM Information**

Prefix: PLAT ID: 0178

User Response

No action; information only.

- **806f070d-0402ffff : Rebuild in progress for Array in system [ComputerSystemElementName]. (Drive 2)**

This message is for the use case when an implementation has detected that an Array Rebuild is in Progress.

May also be shown as 806f070d0402ffff or 0x806f070d0402ffff

Severity

Info

Serviceable

No

Automatically notify support

No

Alert Category

System - Other

SNMP Trap ID

CIM Information

Prefix: PLAT ID: 0178

User Response

No action; information only.

- **806f070d-0403ffff : Rebuild in progress for Array in system [ComputerSystemElementName]. (Drive 3)**

This message is for the use case when an implementation has detected that an Array Rebuild is in Progress.

May also be shown as 806f070d0403ffff or 0x806f070d0403ffff

Severity

Info

Serviceable

No

Automatically notify support

No

Alert Category

System - Other

SNMP Trap ID

CIM Information

Prefix: PLAT ID: 0178

User Response

No action; information only.

- **806f070d-0404ffff : Rebuild in progress for Array in system [ComputerSystemElementName]. (Drive 4)**

This message is for the use case when an implementation has detected that an Array Rebuild is in Progress.

May also be shown as 806f070d0404ffff or 0x806f070d0404ffff

Severity

Info

Serviceable

No

Automatically notify support

No

Alert Category

System - Other

SNMP Trap ID**CIM Information**

Prefix: PLAT ID: 0178

User Response

No action; information only.

- **806f070d-0405ffff : Rebuild in progress for Array in system [ComputerSystemElementName]. (Drive 5)**

This message is for the use case when an implementation has detected that an Array Rebuild is in Progress.

May also be shown as 806f070d0405ffff or 0x806f070d0405ffff

Severity

Info

Serviceable

No

Automatically notify support

No

Alert Category

System - Other

SNMP Trap ID**CIM Information**

Prefix: PLAT ID: 0178

User Response

No action; information only.

- **806f070d-0406ffff : Rebuild in progress for Array in system [ComputerSystemElementName]. (Drive 6)**

This message is for the use case when an implementation has detected that an Array Rebuild is in Progress.

May also be shown as 806f070d0406ffff or 0x806f070d0406ffff

Severity

Info

Serviceable

No

Automatically notify support

No

Alert Category

System - Other

SNMP Trap ID

CIM Information

Prefix: PLAT ID: 0178

User Response

No action; information only.

- **806f070d-0407ffff : Rebuild in progress for Array in system [ComputerSystemElementName]. (Drive 7)**

This message is for the use case when an implementation has detected that an Array Rebuild is in Progress.

May also be shown as 806f070d0407ffff or 0x806f070d0407ffff

Severity

Info

Serviceable

No

Automatically notify support

No

Alert Category

System - Other

SNMP Trap ID

CIM Information

Prefix: PLAT ID: 0178

User Response

No action; information only.

- **806f070d-0410ffff : Rebuild in progress for Array in system [ComputerSystemElementName]. (Ext Drive)**

This message is for the use case when an implementation has detected that an Array Rebuild is in Progress.

May also be shown as 806f070d0410ffff or 0x806f070d0410ffff

Severity

Info

Serviceable

No

Automatically notify support

No

Alert Category

System - Other

SNMP Trap ID**CIM Information**

Prefix: PLAT ID: 0178

User Response

No action; information only.

- **806f072b-2101ffff : A successful software or firmware change was detected on system [ComputerSystemElementName]. (IMM Promotion)**

This message is for the use case when an implementation has detected a Successful Software or Firmware Change.

May also be shown as 806f072b2101ffff or 0x806f072b2101ffff

Severity

Info

Serviceable

No

Automatically notify support

No

Alert Category

System - Other

SNMP Trap ID**CIM Information**

Prefix: PLAT ID: 0450

User Response

No action; information only. IMM Recovery :

- **806f072b-2201ffff : A successful software or firmware change was detected on system [ComputerSystemElementName]. (Bkup Auto Update)**

This message is for the use case when an implementation has detected a Successful Software or Firmware Change.

May also be shown as 806f072b2201ffff or 0x806f072b2201ffff

Severity

Info

Serviceable

No

Automatically notify support

No

Alert Category

System - Other

SNMP Trap ID

CIM Information

Prefix: PLAT ID: 0450

User Response

No action; information only. ROM Recovery :

- **806f0807-0301ffff : [ProcessorElementName] has been Disabled. (CPU 1)**

This message is for the use case when an implementation has detected a Processor has been Disabled.

May also be shown as 806f08070301ffff or 0x806f08070301ffff

Severity

Info

Serviceable

No

Automatically notify support

No

Alert Category

System - Other

SNMP Trap ID

CIM Information

Prefix: PLAT ID: 0061

User Response

No action; information only.

- **806f0813-2582ffff : An Uncorrectable Bus Error has occurred on system [ComputerSystemElementName]. (PCIs)**

This message is for the use case when an implementation has detected a Bus Uncorrectable Error.

May also be shown as 806f08132582ffff or 0x806f08132582ffff

Severity

Error

Serviceable

Yes

Automatically notify support

Yes

Alert Category

Critical - Other

SNMP Trap ID

50

CIM Information

Prefix: PLAT ID: 0240

User Response

1. Check the system-event log.
2. (Trained technician only) Remove the failing microprocessor from the system board (see Removing a microprocessor and heat sink).
3. Check for a server firmware update. Important: Some cluster solutions require specific code levels or coordinated code updates. If the device is part of a cluster solution, verify that the latest level of code is supported for the cluster solution before you update the code.
4. Make sure that the two microprocessors are matching.
5. (Trained technician only) Replace the system board.

- **806f0813-2584ffff : An Uncorrectable Bus Error has occurred on system [ComputerSystemElementName]. (CPUs)**

This message is for the use case when an implementation has detected a Bus Uncorrectable Error.

May also be shown as 806f08132584ffff or 0x806f08132584ffff

Severity

Error

Serviceable

Yes

Automatically notify support

Yes

Alert Category

Critical - Other

SNMP Trap ID

50

CIM Information

Prefix: PLAT ID: 0240

User Response

1. Check the system-event log.
2. (Trained technician only) Remove the failing microprocessor from the system board (see Removing a microprocessor and heat sink).

3. Check for a server firmware update. Important: Some cluster solutions require specific code levels or coordinated code updates. If the device is part of a cluster solution, verify that the latest level of code is supported for the cluster solution before you update the code.
4. Make sure that the two microprocessors are matching.
5. (Trained technician only) Replace the system board.

- **806f0823-2101ffff : Watchdog Timer interrupt occurred for [WatchdogElementName]. (IPMI Watchdog)**

This message is for the use case when an implementation has detected a Watchdog Timer interrupt occurred.

May also be shown as 806f08232101ffff or 0x806f08232101ffff

Severity

Info

Serviceable

No

Automatically notify support

No

Alert Category

System - Other

SNMP Trap ID

CIM Information

Prefix: PLAT **ID:** 0376

User Response

No action; information only.

- **806f090c-2001ffff : [PhysicalMemoryElementName] on Subsystem [MemoryElementName] Throttled. (DIMM 1)**

This message is for the use case when an implementation has detected Memory has been Throttled.

May also be shown as 806f090c2001ffff or 0x806f090c2001ffff

Severity

Warning

Serviceable

Yes

Automatically notify support

No

Alert Category

System - Other

SNMP Trap ID

CIM Information**Prefix:** PLAT ID: 0142**User Response**

1. Reseat the DIMM, and then restart the server.
2. Replace DIMM n. (n = DIMM number)

- **806f090c-2002ffff : [PhysicalMemoryElementName] on Subsystem [MemoryElementName] Throttled. (DIMM 2)**

This message is for the use case when an implementation has detected Memory has been Throttled.

May also be shown as 806f090c2002ffff or 0x806f090c2002ffff

Severity

Warning

Serviceable

Yes

Automatically notify support

No

Alert Category

System - Other

SNMP Trap ID

22

CIM Information**Prefix:** PLAT ID: 0142**User Response**

1. Reseat the DIMM, and then restart the server.
2. Replace DIMM n. (n = DIMM number)

- **806f090c-2003ffff : [PhysicalMemoryElementName] on Subsystem [MemoryElementName] Throttled. (DIMM 3)**

This message is for the use case when an implementation has detected Memory has been Throttled.

May also be shown as 806f090c2003ffff or 0x806f090c2003ffff

Severity

Warning

Serviceable

Yes

Automatically notify support

No

Alert Category

System - Other

SNMP Trap ID

22

CIM Information

Prefix: PLAT ID: 0142

User Response

1. Reseat the DIMM, and then restart the server.
2. Replace DIMM n. (n = DIMM number)

• **806f090c-2004ffff : [PhysicalMemoryElementName] on Subsystem [MemoryElementName] Throttled. (DIMM 4)**

This message is for the use case when an implementation has detected Memory has been Throttled.

May also be shown as 806f090c2004ffff or 0x806f090c2004ffff

Severity

Warning

Serviceable

Yes

Automatically notify support

No

Alert Category

System - Other

SNMP Trap ID

22

CIM Information

Prefix: PLAT ID: 0142

User Response

1. Reseat the DIMM, and then restart the server.
2. Replace DIMM n. (n = DIMM number)

• **806f0a07-0301ffff : [ProcessorElementName] is operating in a Degraded State. (CPU 1)**

This message is for the use case when an implementation has detected a Processor is running in the Degraded state.

May also be shown as 806f0a070301ffff or 0x806f0a070301ffff

Severity

Warning

Serviceable

Yes

Automatically notify support

No

Alert Category

Warning - CPU

SNMP Trap ID

42

CIM Information

Prefix: PLAT ID: 0038

User Response

1. Make sure that the fans are operating, that there are no obstructions to the airflow (front and rear of the server), that the air baffles are in place and correctly installed, and that the server cover is installed and completely closed.
2. Check the ambient temperature. You must be operating within the specifications.
3. Make sure that the heat sink for microprocessor n is installed correctly.
4. (Trained technician only) Replace microprocessor n. (n = microprocessor number)

- **806f0a0c-2001ffff : An Over-Temperature Condition has been detected on the [PhysicalMemoryElementName] on Subsystem [MemoryElementName]. (DIMM 1)**

This message is for the use case when an implementation has detected an Over Temperature Condition for Memory that has been Detected.

May also be shown as 806f0a0c2001ffff or 0x806f0a0c2001ffff

Severity

Error

Serviceable

Yes

Automatically notify support

No

Alert Category

Critical - Temperature

SNMP Trap ID

0

CIM Information

Prefix: PLAT ID: 0146

User Response

1. Make sure that the fans are operating, that there are no obstructions to the airflow, that the air baffles are in place and correctly installed, and that the server cover is installed and completely closed.

2. Make sure that ambient temperature is within the specifications.
3. If a fan has failed, complete the action for a fan failure.
4. Replace DIMM n. (n = DIMM number)

- **806f0a0c-2002ffff : An Over-Temperature Condition has been detected on the [PhysicalMemoryElementName] on Subsystem [MemoryElementName]. (DIMM 2)**

This message is for the use case when an implementation has detected an Over Temperature Condition for Memory that has been Detected.

May also be shown as 806f0a0c2002ffff or 0x806f0a0c2002ffff

Severity

Error

Serviceable

Yes

Automatically notify support

No

Alert Category

Critical - Temperature

SNMP Trap ID

0

CIM Information

Prefix: PLAT **ID:** 0146

User Response

1. Make sure that the fans are operating, that there are no obstructions to the airflow, that the air baffles are in place and correctly installed, and that the server cover is installed and completely closed.
2. Make sure that ambient temperature is within the specifications.
3. If a fan has failed, complete the action for a fan failure.
4. Replace DIMM n. (n = DIMM number)

- **806f0a0c-2003ffff : An Over-Temperature Condition has been detected on the [PhysicalMemoryElementName] on Subsystem [MemoryElementName]. (DIMM 3)**

This message is for the use case when an implementation has detected an Over Temperature Condition for Memory that has been Detected.

May also be shown as 806f0a0c2003ffff or 0x806f0a0c2003ffff

Severity

Error

Serviceable

Yes

Automatically notify support

No

Alert Category

Critical - Temperature

SNMP Trap ID

0

CIM Information

Prefix: PLAT ID: 0146

User Response

1. Make sure that the fans are operating, that there are no obstructions to the airflow, that the air baffles are in place and correctly installed, and that the server cover is installed and completely closed.
2. Make sure that ambient temperature is within the specifications.
3. If a fan has failed, complete the action for a fan failure.
4. Replace DIMM n. (n = DIMM number)

- **806f0a0c-2004ffff : An Over-Temperature Condition has been detected on the [PhysicalMemoryElementName] on Subsystem [MemoryElementName]. (DIMM 4)**

This message is for the use case when an implementation has detected an Over Temperature Condition for Memory that has been Detected.

May also be shown as 806f0a0c2004ffff or 0x806f0a0c2004ffff

Severity

Error

Serviceable

Yes

Automatically notify support

No

Alert Category

Critical - Temperature

SNMP Trap ID

0

CIM Information

Prefix: PLAT ID: 0146

User Response

1. Make sure that the fans are operating, that there are no obstructions to the airflow, that the air baffles are in place and correctly installed, and that the server cover is installed and completely closed.
2. Make sure that ambient temperature is within the specifications.
3. If a fan has failed, complete the action for a fan failure.

4. Replace DIMM n. (n = DIMM number)

- **81010002-0701ffff : Numeric sensor [NumericSensorElementName] going low (lower non-critical) has deasserted. (CMOS Battery)**

This message is for the use case when an implementation has detected a Lower Non-critical sensor going low has deasserted.

May also be shown as 810100020701ffff or 0x810100020701ffff

Severity

Info

Serviceable

No

Automatically notify support

No

Alert Category

Warning - Voltage

SNMP Trap ID

13

CIM Information

Prefix: PLAT ID: 0477

User Response

No action; information only.

- **81010202-0701ffff : Numeric sensor [NumericSensorElementName] going low (lower critical) has deasserted. (CMOS Battery)**

This message is for the use case when an implementation has detected a Lower Critical sensor going low has deasserted.

May also be shown as 810102020701ffff or 0x810102020701ffff

Severity

Info

Serviceable

No

Automatically notify support

No

Alert Category

Critical - Voltage

SNMP Trap ID

1

CIM Information

Prefix: PLAT ID: 0481

User Response

No action; information only. SysBrd 12V : SysBrd 3.3V : SysBrd 5V :

- **81010204-1d01ffff : Numeric sensor [NumericSensorElementName] going low (lower critical) has deasserted. (Fan 1 Tach)**

This message is for the use case when an implementation has detected a Lower Critical sensor going low has deasserted.

May also be shown as 810102041d01ffff or 0x810102041d01ffff

Severity

Info

Serviceable

No

Automatically notify support

No

Alert Category

Critical - Fan Failure

SNMP Trap ID

11

CIM Information

Prefix: PLAT **ID:** 0481

User Response

No action; information only.

- **81010204-1d02ffff : Numeric sensor [NumericSensorElementName] going low (lower critical) has deasserted. (Fan 2 Tach)**

This message is for the use case when an implementation has detected a Lower Critical sensor going low has deasserted.

May also be shown as 810102041d02ffff or 0x810102041d02ffff

Severity

Info

Serviceable

No

Automatically notify support

No

Alert Category

Critical - Fan Failure

SNMP Trap ID

11

CIM Information

Prefix: PLAT ID: 0481

User Response

No action; information only.

- **81010204-1d03ffff : Numeric sensor [NumericSensorElementName] going low (lower critical) has deasserted. (Fan 3 Tach)**

This message is for the use case when an implementation has detected a Lower Critical sensor going low has deasserted.

May also be shown as 810102041d03ffff or 0x810102041d03ffff

Severity

Info

Serviceable

No

Automatically notify support

No

Alert Category

Critical - Fan Failure

SNMP Trap ID

11

CIM Information

Prefix: PLAT ID: 0481

User Response

No action; information only.

- **81010204-1d04ffff : Numeric sensor [NumericSensorElementName] going low (lower critical) has deasserted. (Fan 4 Tach)**

This message is for the use case when an implementation has detected a Lower Critical sensor going low has deasserted.

May also be shown as 810102041d04ffff or 0x810102041d04ffff

Severity

Info

Serviceable

No

Automatically notify support

No

Alert Category

Critical - Fan Failure

SNMP Trap ID

11

CIM Information

Prefix: PLAT ID: 0481

User Response

No action; information only.

- **81010701-0701ffff : Numeric sensor [NumericSensorElementName] going high (upper non-critical) has deasserted. (Ambient 1 Temp)**

This message is for the use case when an implementation has detected an Upper Non-critical sensor going high has deasserted.

May also be shown as 810107010701ffff or 0x810107010701ffff

Severity

Info

Serviceable

No

Automatically notify support

No

Alert Category

Warning - Temperature

SNMP Trap ID

12

CIM Information

Prefix: PLAT ID: 0491

User Response

No action; information only.

- **81010701-0704ffff : Numeric sensor [NumericSensorElementName] going high (upper non-critical) has deasserted. (PCIE Temp)**

This message is for the use case when an implementation has detected an Upper Non-critical sensor going high has deasserted.

May also be shown as 810107010704ffff or 0x810107010704ffff

Severity

Info

Serviceable

No

Automatically notify support

No

Alert Category

Warning - Temperature

SNMP Trap ID

12

CIM Information

Prefix: PLAT **ID:** 0491

User Response

No action; information only.

- **81010701-0705ffff : Numeric sensor [NumericSensorElementName] going high (upper non-critical) has deasserted. (CPU VRM Temp)**

This message is for the use case when an implementation has detected an Upper Non-critical sensor going high has deasserted.

May also be shown as 810107010705ffff or 0x810107010705ffff

Severity

Info

Serviceable

No

Automatically notify support

No

Alert Category

Warning - Temperature

SNMP Trap ID

12

CIM Information

Prefix: PLAT **ID:** 0491

User Response

No action; information only.

- **81010701-2701ffff : Numeric sensor [NumericSensorElementName] going high (upper non-critical) has deasserted. (Ambient 2 Temp)**

This message is for the use case when an implementation has detected an Upper Non-critical sensor going high has deasserted.

May also be shown as 810107012701ffff or 0x810107012701ffff

Severity

Info

Serviceable

No

Automatically notify support

No

Alert Category

Warning - Temperature

SNMP Trap ID

12

CIM Information**Prefix:** PLAT ID: 0491**User Response**

No action; information only.

- **81010701-2d01ffff : Numeric sensor [NumericSensorElementName] going high (upper non-critical) has deasserted. (PCH Temp)**

This message is for the use case when an implementation has detected an Upper Non-critical sensor going high has deasserted.

May also be shown as 810107012d01ffff or 0x810107012d01ffff

Severity

Info

Serviceable

No

Automatically notify support

No

Alert Category

Warning - Temperature

SNMP Trap ID

12

CIM Information**Prefix:** PLAT ID: 0491**User Response**

No action; information only.

- **81010901-0701ffff : Numeric sensor [NumericSensorElementName] going high (upper critical) has deasserted. (Ambient 1 Temp)**

This message is for the use case when an implementation has detected an Upper Critical sensor going high has deasserted.

May also be shown as 810109010701ffff or 0x810109010701ffff

Severity

Info

Serviceable

No

Automatically notify support

No

Alert Category

Critical - Temperature

SNMP Trap ID

0

CIM Information

Prefix: PLAT ID: 0495

User Response

No action; information only.

- **81010901-0704ffff : Numeric sensor [NumericSensorElementName] going high (upper critical) has deasserted. (PCIE Temp)**

This message is for the use case when an implementation has detected an Upper Critical sensor going high has deasserted.

May also be shown as 810109010704ffff or 0x810109010704ffff

Severity

Info

Serviceable

No

Automatically notify support

No

Alert Category

Critical - Temperature

SNMP Trap ID

0

CIM Information

Prefix: PLAT ID: 0495

User Response

No action; information only.

- **81010901-0705ffff : Numeric sensor [NumericSensorElementName] going high (upper critical) has deasserted. (CPU VRM Temp)**

This message is for the use case when an implementation has detected an Upper Critical sensor going high has deasserted.

May also be shown as 810109010705ffff or 0x810109010705ffff

Severity

Info

Serviceable

No

Automatically notify support

No

Alert Category

Critical - Temperature

SNMP Trap ID

0

CIM Information

Prefix: PLAT ID: 0495

User Response

No action; information only.

- **81010901-2701ffff : Numeric sensor [NumericSensorElementName] going high (upper critical) has deasserted. (Ambient 2 Temp)**

This message is for the use case when an implementation has detected an Upper Critical sensor going high has deasserted.

May also be shown as 810109012701ffff or 0x810109012701ffff

Severity

Info

Serviceable

No

Automatically notify support

No

Alert Category

Critical - Temperature

SNMP Trap ID

0

CIM Information

Prefix: PLAT ID: 0495

User Response

No action; information only.

- **81010901-2d01ffff : Numeric sensor [NumericSensorElementName] going high (upper critical) has deasserted. (PCH Temp)**

This message is for the use case when an implementation has detected an Upper Critical sensor going high has deasserted.

May also be shown as 810109012d01ffff or 0x810109012d01ffff

Severity

Info

Serviceable

No

Automatically notify support

No

Alert Category

Critical - Temperature

SNMP Trap ID

0

CIM Information

Prefix: PLAT ID: 0495

User Response

No action; information only.

- **81010902-0701ffff : Numeric sensor [NumericSensorElementName] going high (upper critical) has deasserted. (SysBrd 12V)**

This message is for the use case when an implementation has detected an Upper Critical sensor going high has deasserted.

May also be shown as 810109020701ffff or 0x810109020701ffff

Severity

Info

Serviceable

No

Automatically notify support

No

Alert Category

Critical - Voltage

SNMP Trap ID

1

CIM Information

Prefix: PLAT ID: 0495

User Response

No action; information only. SysBrd 3.3V : SysBrd 5V :

- **81010b01-0701ffff : Numeric sensor [NumericSensorElementName] going high (upper non-recoverable) has deasserted. (Ambient 1 Temp)**

This message is for the use case when an implementation has detected an Upper Non-recoverable sensor going high has deasserted.

May also be shown as 81010b010701ffff or 0x81010b010701ffff

Severity

Info

Serviceable

No

Automatically notify support

No

Alert Category

Critical - Temperature

SNMP Trap ID

0

CIM Information

Prefix: PLAT ID: 0499

User Response

No action; information only.

- **81010b01-0704ffff : Numeric sensor [NumericSensorElementName] going high (upper non-recoverable) has deasserted. (PCIE Temp)**

This message is for the use case when an implementation has detected an Upper Non-recoverable sensor going high has deasserted.

May also be shown as 81010b010704ffff or 0x81010b010704ffff

Severity

Info

Serviceable

No

Automatically notify support

No

Alert Category

Critical - Temperature

SNMP Trap ID

0

CIM Information

Prefix: PLAT ID: 0499

User Response

No action; information only.

- **81010b01-0705ffff : Numeric sensor [NumericSensorElementName] going high (upper non-recoverable) has deasserted. (CPU VRM Temp)**

This message is for the use case when an implementation has detected an Upper Non-recoverable sensor going high has deasserted.

May also be shown as 81010b010705ffff or 0x81010b010705ffff

Severity

Info

Serviceable

No

Automatically notify support

No

Alert Category

Critical - Temperature

SNMP Trap ID

0

CIM Information

Prefix: PLAT ID: 0499

User Response

No action; information only.

- **81010b01-2701ffff : Numeric sensor [NumericSensorElementName] going high (upper non-recoverable) has deasserted. (Ambient 2 Temp)**

This message is for the use case when an implementation has detected an Upper Non-recoverable sensor going high has deasserted.

May also be shown as 81010b012701ffff or 0x81010b012701ffff

Severity

Info

Serviceable

No

Automatically notify support

No

Alert Category

Critical - Temperature

SNMP Trap ID

0

CIM Information

Prefix: PLAT ID: 0499

User Response

No action; information only.

- **81010b01-2d01ffff : Numeric sensor [NumericSensorElementName] going high (upper non-recoverable) has deasserted. (PCH Temp)**

This message is for the use case when an implementation has detected an Upper Non-recoverable sensor going high has deasserted.

May also be shown as 81010b012d01ffff or 0x81010b012d01ffff

Severity

Info

Serviceable

No

Automatically notify support

No

Alert Category

Critical - Temperature

SNMP Trap ID

0

CIM Information

Prefix: PLAT ID: 0499

User Response

No action; information only.

- **81030006-2101ffff : Sensor [SensorElementName] has asserted. (Sig Verify Fail)**

This message is for the use case when an implementation has detected a Sensor has asserted.

May also be shown as 810300062101ffff or 0x810300062101ffff

Severity

Info

Serviceable

No

Automatically notify support

No

Alert Category

System - Other

SNMP Trap ID**CIM Information**

Prefix: PLAT ID: 0508

User Response

No action; information only.

- **81030012-2301ffff : Sensor [SensorElementName] has asserted. (OS RealTime Mod)**

This message is for the use case when an implementation has detected a Sensor has asserted.

May also be shown as 810300122301ffff or 0x810300122301ffff

Severity

Info

Serviceable

No

Automatically notify support

No

Alert Category

System - Other

SNMP Trap ID**CIM Information**

Prefix: PLAT ID: 0508

User Response

No action; information only.

- **81030021-0782ffff : Sensor [SensorElementName] has asserted. (PCIe Dev LK Down)**

This message is for the use case when an implementation has detected a Sensor has asserted.

May also be shown as 810300210782ffff or 0x810300210782ffff

Severity

Info

Serviceable

No

Automatically notify support

No

Alert Category

System - Other

SNMP Trap ID**CIM Information**

Prefix: PLAT ID: 0508

User Response

No action; information only.

- **8103010c-2581ffff : Sensor [SensorElementName] has deasserted. (Non-Auth DIMMs)**

This message is for the use case when an implementation has detected a Sensor has deasserted.

May also be shown as 8103010c2581ffff or 0x8103010c2581ffff

Severity

Info

Serviceable

No

Automatically notify support

No

Alert Category

System - Other

SNMP Trap ID**CIM Information**

Prefix: PLAT ID: 0509

User Response

No action; information only.

- **81030112-0601ffff : Sensor [SensorElementName] has deasserted. (SMM Mode)**

This message is for the use case when an implementation has detected a Sensor has deasserted.

May also be shown as 810301120601ffff or 0x810301120601ffff

Severity

Info

Serviceable

No

Automatically notify support

No

Alert Category

System - Other

SNMP Trap ID**CIM Information**

Prefix: PLAT ID: 0509

User Response

No action; information only. SMM Monitor :

- **81030121-0782ffff : Sensor [SensorElementName] has deasserted. (PCIe Dev LK Down)**

This message is for the use case when an implementation has detected a Sensor has deasserted.

May also be shown as 810301210782ffff or 0x810301210782ffff

Severity

Info

Serviceable

No

Automatically notify support

No

Alert Category

System - Other

SNMP Trap ID

CIM Information

Prefix: PLAT ID: 0509

User Response

No action; information only.

- **8107010d-2582ffff : Sensor [SensorElementName] has deasserted the transition from normal to non-critical state. (RAID Vol State)**

This message is for the use case when an implementation has detected that a Sensor has deasserted a transition to non-critical from normal.

May also be shown as 8107010d2582ffff or 0x8107010d2582ffff

Severity

Info

Serviceable

No

Automatically notify support

No

Alert Category

Warning - Other

SNMP Trap ID

60

CIM Information

Prefix: PLAT ID: 0521

User Response

No action; information only.

- **8107010f-2201ffff : Sensor [SensorElementName] has deasserted the transition from normal to non-critical state. (GPT Status)**

This message is for the use case when an implementation has detected that a Sensor has deasserted a transition to non-critical from normal.

May also be shown as 8107010f2201ffff or 0x8107010f2201ffff

Severity

Info

Serviceable

No

Automatically notify support

No

Alert Category

Warning - Other

SNMP Trap ID

60

CIM Information

Prefix: PLAT ID: 0521

User Response

No action; information only.

- **8107010f-2582ffff : Sensor [SensorElementName] has deasserted the transition from normal to non-critical state. (I/O Resources)**

This message is for the use case when an implementation has detected that a Sensor has deasserted a transition to non-critical from normal.

May also be shown as 8107010f2582ffff or 0x8107010f2582ffff

Severity

Info

Serviceable

No

Automatically notify support

No

Alert Category

Warning - Other

SNMP Trap ID

60

CIM Information

Prefix: PLAT ID: 0521

User Response

No action; information only.

- **81070128-2e01ffff : Sensor [SensorElementName] has deasserted the transition from normal to non-critical state. (ME Recovery)**

This message is for the use case when an implementation has detected that a Sensor has deasserted a transition to non-critical from normal.

May also be shown as 810701282e01ffff or 0x810701282e01ffff

Severity

Info

Serviceable

No

Automatically notify support

No

Alert Category

Warning - Other

SNMP Trap ID

60

CIM Information

Prefix: PLAT ID: 0521

User Response

No action; information only.

- **81070201-0301ffff : Sensor [SensorElementName] has transitioned to a less severe state from critical. (CPU 1 OverTemp)**

This message is for the use case when an implementation has detected a Sensor transition to less severe from critical.

May also be shown as 810702010301ffff or 0x810702010301ffff

Severity

Info

Serviceable

No

Automatically notify support

No

Alert Category

Critical - Temperature

SNMP Trap ID

0

CIM Information

Prefix: PLAT ID: 0523

User Response

No action; information only.

- **81070202-0701ffff : Sensor [SensorElementName] has transitioned to a less severe state from critical. (SysBrd Vol Fault)**

This message is for the use case when an implementation has detected a Sensor transition to less severe from critical.

May also be shown as 810702020701ffff or 0x810702020701ffff

Severity

Info

Serviceable

No

Automatically notify support

No

Alert Category

Critical - Voltage

SNMP Trap ID

1

CIM Information

Prefix: PLAT ID: 0523

User Response

No action; information only.

- **81070204-0a01ffff : Sensor [SensorElementName] has transitioned to a less severe state from critical. (PS 1 Fan Fault)**

This message is for the use case when an implementation has detected a Sensor transition to less severe from critical.

May also be shown as 810702040a01ffff or 0x810702040a01ffff

Severity

Info

Serviceable

No

Automatically notify support

No

Alert Category

Critical - Fan Failure

SNMP Trap ID

11

CIM Information

Prefix: PLAT ID: 0523

User Response

No action; information only.

- **81070204-0a02ffff : Sensor [SensorElementName] has transitioned to a less severe state from critical. (PS 2 Fan Fault)**

This message is for the use case when an implementation has detected a Sensor transition to less severe from critical.

May also be shown as 810702040a02ffff or 0x810702040a02ffff

Severity

Info

Serviceable

No

Automatically notify support

No

Alert Category

Critical - Fan Failure

SNMP Trap ID

11

CIM Information

Prefix: PLAT ID: 0523

User Response

No action; information only.

- **81070208-0a01ffff : Sensor [SensorElementName] has transitioned to a less severe state from critical. (PS 1 Therm Fault)**

This message is for the use case when an implementation has detected a Sensor transition to less severe from critical.

May also be shown as 810702080a01ffff or 0x810702080a01ffff

Severity

Info

Serviceable

No

Automatically notify support

No

Alert Category

Critical - Power

SNMP Trap ID

4

CIM Information

Prefix: PLAT ID: 0523

User Response

No action; information only.

- **81070208-0a02ffff : Sensor [SensorElementName] has transitioned to a less severe state from critical. (PS 2 Therm Fault)**

This message is for the use case when an implementation has detected a Sensor transition to less severe from critical.

May also be shown as 810702080a02ffff or 0x810702080a02ffff

Severity

Info

Serviceable

No

Automatically notify support

No

Alert Category

Critical - Power

SNMP Trap ID

4

CIM Information

Prefix: PLAT ID: 0523

User Response

No action; information only.

- **8107020d-2582ffff : Sensor [SensorElementName] has transitioned to a less severe state from critical. (RAID Vol State)**

This message is for the use case when an implementation has detected a Sensor transition to less severe from critical.

May also be shown as 8107020d2582ffff or 0x8107020d2582ffff

Severity

Info

Serviceable

No

Automatically notify support

No

Alert Category

Critical - Other

SNMP Trap ID

50

CIM Information

Prefix: PLAT ID: 0523

User Response

No action; information only.

- **8107020f-2201ffff : Sensor [SensorElementName] has transitioned to a less severe state from critical. (TXT ACM Module)**

This message is for the use case when an implementation has detected a Sensor transition to less severe from critical.

May also be shown as 8107020f2201ffff or 0x8107020f2201ffff

Severity

Info

Serviceable

No

Automatically notify support

No

Alert Category

Critical - Other

SNMP Trap ID

50

CIM Information

Prefix: PLAT ID: 0523

User Response

No action; information only.

- **8107020f-2582ffff : Sensor [SensorElementName] has transitioned to a less severe state from critical. (I/O Resources)**

This message is for the use case when an implementation has detected a Sensor transition to less severe from critical.

May also be shown as 8107020f2582ffff or 0x8107020f2582ffff

Severity

Info

Serviceable

No

Automatically notify support

No

Alert Category

Critical - Other

SNMP Trap ID

50

CIM Information

Prefix: PLAT ID: 0523

User Response

No action; information only.

- **81070214-2201ffff : Sensor [SensorElementName] has transitioned to a less severe state from critical. (TPM Lock)**

This message is for the use case when an implementation has detected a Sensor transition to less severe from critical.

May also be shown as 810702142201ffff or 0x810702142201ffff

Severity

Info

Serviceable

No

Automatically notify support

No

Alert Category

Critical - Other

SNMP Trap ID

50

CIM Information

Prefix: PLAT ID: 0523

User Response

No action; information only.

- **81070219-0701ffff : Sensor [SensorElementName] has transitioned to a less severe state from critical. (SysBrd Fault)**

This message is for the use case when an implementation has detected a Sensor transition to less severe from critical.

May also be shown as 810702190701ffff or 0x810702190701ffff

Severity

Info

Serviceable

No

Automatically notify support

No

Alert Category

Critical - Other

SNMP Trap ID

50

CIM Information

Prefix: PLAT ID: 0523

User Response

No action; information only.

- **81070228-2e01ffff : Sensor [SensorElementName] has transitioned to a less severe state from critical. (ME Error)**

This message is for the use case when an implementation has detected a Sensor transition to less severe from critical.

May also be shown as 810702282e01ffff or 0x810702282e01ffff

Severity

Info

Serviceable

No

Automatically notify support

No

Alert Category

Critical - Other

SNMP Trap ID

50

CIM Information

Prefix: PLAT ID: 0523

User Response

No action; information only. ME Flash Error :

- **81070301-0301ffff : Sensor [SensorElementName] has deasserted the transition to non-recoverable from a less severe state. (CPU 1 OverTemp)**

This message is for the use case when an implementation has detected that the Sensor transition to non-recoverable from less severe has deasserted.

May also be shown as 810703010301ffff or 0x810703010301ffff

Severity

Info

Serviceable

No

Automatically notify support

No

Alert Category

Critical - Temperature

SNMP Trap ID

0

CIM Information

Prefix: PLAT ID: 0525

User Response

No action; information only.

- **8107030d-2582ffff : Sensor [SensorElementName] has deasserted the transition to non-recoverable from a less severe state. (RAID Vol State)**

This message is for the use case when an implementation has detected that the Sensor transition to non-recoverable from less severe has deasserted.

May also be shown as 8107030d2582ffff or 0x8107030d2582ffff

Severity

Info

Serviceable

No

Automatically notify support

No

Alert Category

Critical - Other

SNMP Trap ID

50

CIM Information**Prefix: PLAT ID: 0525****User Response**

No action; information only.

- **81070608-0a01ffff : Sensor [SensorElementName] has deasserted the transition to non-recoverable. (PS1 12V OC Fault)**

This message is for the use case when an implementation has detected that the Sensor transition to non-recoverable has deasserted.

May also be shown as 810706080a01ffff or 0x810706080a01ffff

Severity

Info

Serviceable

No

Automatically notify support

No

Alert Category

Critical - Power

SNMP Trap ID

4

CIM Information**Prefix: PLAT ID: 0531****User Response**

No action; information only. PS1 12V OV Fault : PS1 12V UV Fault : PS1 12Vaux Fault :

- **81070608-0a02ffff : Sensor [SensorElementName] has deasserted the transition to non-recoverable. (PS2 12V OC Fault)**

This message is for the use case when an implementation has detected that the Sensor transition to non-recoverable has deasserted.

May also be shown as 810706080a02ffff or 0x810706080a02ffff

Severity

Info

Serviceable

No

Automatically notify support

No

Alert Category

Critical - Power

SNMP Trap ID

4

CIM Information

Prefix: PLAT ID: 0531

User Response

No action; information only. PS2 12V OV Fault : PS2 12V UV Fault : PS2 12Vaux Fault :

- **81080025-3701ffff : Device [LogicalDeviceElementName] has been added. (Thermal Board)**

This message is for the use case when an implementation has detected a Device was inserted.

May also be shown as 810800253701ffff or 0x810800253701ffff

Severity

Info

Serviceable

No

Automatically notify support

No

Alert Category

System - Other

SNMP Trap ID**CIM Information**

Prefix: PLAT ID: 0536

User Response

No action; information only.

- **81080125-3701ffff : Device [LogicalDeviceElementName] has been removed from unit [PhysicalPackageElementName]. (Thermal Board)**

This message is for the use case when an implementation has detected a Device was removed.

May also be shown as 810801253701ffff or 0x810801253701ffff

Severity

Info

Serviceable

No

Automatically notify support

No

Alert Category

System - Other

SNMP Trap ID**CIM Information**

Prefix: PLAT ID: 0537

User Response

No action; information only.

- **816f0007-0301ffff : [ProcessorElementName] has Recovered from IERR. (CPU 1)**

This message is for the use case when an implementation has detected a Processor Recovered - IERR Condition.

May also be shown as 816f00070301ffff or 0x816f00070301ffff

Severity

Info

Serviceable

No

Automatically notify support

No

Alert Category

Critical - CPU

SNMP Trap ID

40

CIM Information

Prefix: PLAT ID: 0043

User Response

No action; information only.

- **816f0008-0a01ffff : [PowerSupplyElementName] has been removed from container [PhysicalPackageElementName]. (Power Supply 1)**

This message is for the use case when an implementation has detected a Power Supply has been removed.

May also be shown as 816f00080a01ffff or 0x816f00080a01ffff

Severity

Info

Serviceable

No

Automatically notify support

No

Alert Category

System - Other

SNMP Trap ID**CIM Information**

Prefix: PLAT ID: 0085

User Response

No action; information only.

- **816f0008-0a02ffff : [PowerSupplyElementName] has been removed from container [PhysicalPackageElementName]. (Power Supply 2)**

This message is for the use case when an implementation has detected a Power Supply has been removed.

May also be shown as 816f00080a02ffff or 0x816f00080a02ffff

Severity

Info

Serviceable

No

Automatically notify support

No

Alert Category

System - Other

SNMP Trap ID**CIM Information**

Prefix: PLAT ID: 0085

User Response

No action; information only.

- **816f0009-1301ffff : [PowerSupplyElementName] has been turned on. (Host Power)**

This message is for the use case when an implementation has detected a Power Unit that has been Enabled.

May also be shown as 816f00091301ffff or 0x816f00091301ffff

Severity

Info

Serviceable

No

Automatically notify support

No

Alert Category

System - Power On

SNMP Trap ID

24

CIM Information

Prefix: PLAT ID: 0107

User Response

No action; information only.

- **816f000d-0400ffff : The Drive [StorageVolumeElementName] has been removed from unit [PhysicalPackageElementName]. (Drive 0)**

This message is for the use case when an implementation has detected a Drive has been Removed.

May also be shown as 816f000d0400ffff or 0x816f000d0400ffff

Severity

Info

Serviceable

No

Automatically notify support

No

Alert Category

System - Other

SNMP Trap ID

22

CIM Information

Prefix: PLAT ID: 0163

User Response

1. Reseat hard disk drive n.(n = hard disk drive number). Wait 1 minute or more before reinstalling the drive.
2. Replace the hard disk drive.
3. Make sure that the disk firmware and RAID controller firmware are at the latest level.
4. Check the SAS cable.

- **816f000d-0401ffff : The Drive [StorageVolumeElementName] has been removed from unit [PhysicalPackageElementName]. (Drive 1)**

This message is for the use case when an implementation has detected a Drive has been Removed.

May also be shown as 816f000d0401ffff or 0x816f000d0401ffff

Severity

Info

Serviceable

No

Automatically notify support

No

Alert Category

System - Other

SNMP Trap ID

22

CIM Information

Prefix: PLAT ID: 0163

User Response

1. Reseat hard disk drive n.(n = hard disk drive number). Wait 1 minute or more before reinstalling the drive.
2. Replace the hard disk drive.
3. Make sure that the disk firmware and RAID controller firmware are at the latest level.
4. Check the SAS cable.

- **816f000d-0402ffff : The Drive [StorageVolumeElementName] has been removed from unit [PhysicalPackageElementName]. (Drive 2)**

This message is for the use case when an implementation has detected a Drive has been Removed.

May also be shown as 816f000d0402ffff or 0x816f000d0402ffff

Severity

Info

Serviceable

No

Automatically notify support

No

Alert Category

System - Other

SNMP Trap ID

22

CIM Information

Prefix: PLAT ID: 0163

User Response

1. Reseat hard disk drive n.(n = hard disk drive number). Wait 1 minute or more before reinstalling the drive.
2. Replace the hard disk drive.
3. Make sure that the disk firmware and RAID controller firmware are at the latest level.
4. Check the SAS cable.

- **816f000d-0403ffff : The Drive [StorageVolumeElementName] has been removed from unit [PhysicalPackageElementName]. (Drive 3)**

This message is for the use case when an implementation has detected a Drive has been Removed.

May also be shown as 816f000d0403ffff or 0x816f000d0403ffff

Severity

Info

Serviceable

No

Automatically notify support

No

Alert Category

System - Other

SNMP Trap ID

22

CIM Information

Prefix: PLAT **ID:** 0163

User Response

1. Reseat hard disk drive n.(n = hard disk drive number). Wait 1 minute or more before reinstalling the drive.
2. Replace the hard disk drive.
3. Make sure that the disk firmware and RAID controller firmware are at the latest level.
4. Check the SAS cable.

- **816f000d-0404ffff : The Drive [StorageVolumeElementName] has been removed from unit [PhysicalPackageElementName]. (Drive 4)**

This message is for the use case when an implementation has detected a Drive has been Removed.

May also be shown as 816f000d0404ffff or 0x816f000d0404ffff

Severity

Info

Serviceable

No

Automatically notify support

No

Alert Category

System - Other

SNMP Trap ID

22

CIM Information

Prefix: PLAT ID: 0163

User Response

1. Reseat hard disk drive n.(n = hard disk drive number). Wait 1 minute or more before reinstalling the drive.
2. Replace the hard disk drive.
3. Make sure that the disk firmware and RAID controller firmware are at the latest level.
4. Check the SAS cable.

- **816f000d-0405ffff : The Drive [StorageVolumeElementName] has been removed from unit [PhysicalPackageElementName]. (Drive 5)**

This message is for the use case when an implementation has detected a Drive has been Removed.

May also be shown as 816f000d0405ffff or 0x816f000d0405ffff

Severity

Info

Serviceable

No

Automatically notify support

No

Alert Category

System - Other

SNMP Trap ID

22

CIM Information

Prefix: PLAT ID: 0163

User Response

1. Reseat hard disk drive n.(n = hard disk drive number). Wait 1 minute or more before reinstalling the drive.
2. Replace the hard disk drive.
3. Make sure that the disk firmware and RAID controller firmware are at the latest level.
4. Check the SAS cable.

- **816f000d-0406ffff : The Drive [StorageVolumeElementName] has been removed from unit [PhysicalPackageElementName]. (Drive 6)**

This message is for the use case when an implementation has detected a Drive has been Removed.

May also be shown as 816f000d0406ffff or 0x816f000d0406ffff

Severity

Info

Serviceable

No

Automatically notify support

No

Alert Category

System - Other

SNMP Trap ID

22

CIM Information

Prefix: PLAT ID: 0163

User Response

1. Reseat hard disk drive n.(n = hard disk drive number). Wait 1 minute or more before reinstalling the drive.
2. Replace the hard disk drive.
3. Make sure that the disk firmware and RAID controller firmware are at the latest level.
4. Check the SAS cable.

- **816f000d-0407ffff : The Drive [StorageVolumeElementName] has been removed from unit [PhysicalPackageElementName]. (Drive 7)**

This message is for the use case when an implementation has detected a Drive has been Removed.

May also be shown as 816f000d0407ffff or 0x816f000d0407ffff

Severity

Info

Serviceable

No

Automatically notify support

No

Alert Category

System - Other

SNMP Trap ID

22

CIM Information

Prefix: PLAT ID: 0163

User Response

1. Reseat hard disk drive n.(n = hard disk drive number). Wait 1 minute or more before reinstalling the drive.
2. Replace the hard disk drive.
3. Make sure that the disk firmware and RAID controller firmware are at the latest level.
4. Check the SAS cable.

- **816f000d-0410ffff : The Drive [StorageVolumeElementName] has been removed from unit [PhysicalPackageElementName]. (Ext Drive)**

This message is for the use case when an implementation has detected a Drive has been Removed.

May also be shown as 816f000d0410ffff or 0x816f000d0410ffff

Severity

Info

Serviceable

No

Automatically notify support

No

Alert Category

System - Other

SNMP Trap ID

22

CIM Information

Prefix: PLAT ID: 0163

User Response

1. Reseat hard disk drive n.(n = hard disk drive number). Wait 1 minute or more before reinstalling the drive.
2. Replace the hard disk drive.
3. Make sure that the disk firmware and RAID controller firmware are at the latest level.
4. Check the SAS cable.

- **816f000f-2201ffff : The System [ComputerSystemElementName] has detected a POST Error deassertion. (ABR Status)**

This message is for the use case when an implementation has detected that Post Error has deasserted.

May also be shown as 816f000f2201ffff or 0x816f000f2201ffff

Severity

Info

Serviceable

No

Automatically notify support

No

Alert Category

Critical - Other

SNMP Trap ID

50

CIM Information

Prefix: PLAT ID: 0185

User Response

No action; information only. Firmware Error : Sys Boot Status :

- **816f0013-1701ffff : System [ComputerSystemElementName] has recovered from a diagnostic interrupt. (NMI State)**

This message is for the use case when an implementation has detected a recovery from a Front Panel NMI / Diagnostic Interrupt

May also be shown as 816f00131701ffff or 0x816f00131701ffff

Severity

Info

Serviceable

No

Automatically notify support

No

Alert Category

Critical - Other

SNMP Trap ID

50

CIM Information

Prefix: PLAT ID: 0223

User Response

No action; information only.

- **816f0021-2201ffff : Fault condition removed on slot [PhysicalConnectorElementName] on system [ComputerSystemElementName]. (No Op ROM Space)**

This message is for the use case when an implementation has detected a Fault condition in a slot has been removed.

May also be shown as 816f00212201ffff or 0x816f00212201ffff

Severity

Info

Serviceable

No

Automatically notify support

No

Alert Category

Critical - Other

SNMP Trap ID

50

CIM Information

Prefix: PLAT ID: 0331

User Response

No action; information only.

- **816f0021-2582ffff : Fault condition removed on slot [PhysicalConnectorElementName] on system [ComputerSystemElementName]. (All PCI Error)**

This message is for the use case when an implementation has detected a Fault condition in a slot has been removed.

May also be shown as 816f00212582ffff or 0x816f00212582ffff

Severity

Info

Serviceable

No

Automatically notify support

No

Alert Category

Critical - Other

SNMP Trap ID

50

CIM Information

Prefix: PLAT ID: 0331

User Response

No action; information only. One of PCI Error :

- **816f0021-3001ffff : Fault condition removed on slot [PhysicalConnectorElementName] on system [ComputerSystemElementName]. (PCI 1)**

This message is for the use case when an implementation has detected a Fault condition in a slot has been removed.

May also be shown as 816f00213001ffff or 0x816f00213001ffff

Severity

Info

Serviceable

No

Automatically notify support

No

Alert Category

Critical - Other

SNMP Trap ID

50

CIM Information**Prefix: PLAT ID: 0331****User Response**

No action; information only.

- **816f0021-3002ffff : Fault condition removed on slot [PhysicalConnectorElementName] on system [ComputerSystemElementName]. (PCI 2)**

This message is for the use case when an implementation has detected a Fault condition in a slot has been removed.

May also be shown as 816f00213002ffff or 0x816f00213002ffff

Severity

Info

Serviceable

No

Automatically notify support

No

Alert Category

Critical - Other

SNMP Trap ID

50

CIM Information**Prefix: PLAT ID: 0331****User Response**

No action; information only.

- **816f0107-0301ffff : An Over-Temperature Condition has been removed on [ProcessorElementName]. (CPU 1)**

This message is for the use case when an implementation has detected a Over-Temperature Condition has been Removed for Processor.

May also be shown as 816f01070301ffff or 0x816f01070301ffff

Severity

Info

Serviceable

No

Automatically notify support

No

Alert Category

Critical - Temperature

SNMP Trap ID

0

CIM Information

Prefix: PLAT ID: 0037

User Response

No action; information only.

- **816f0108-0a01ffff : [PowerSupplyElementName] has returned to OK status. (Power Supply 1)**

This message is for the use case when an implementation has detected a Power Supply return to normal operational status.

May also be shown as 816f01080a01ffff or 0x816f01080a01ffff

Severity

Info

Serviceable

No

Automatically notify support

No

Alert Category

Critical - Power

SNMP Trap ID

4

CIM Information

Prefix: PLAT ID: 0087

User Response

No action; information only.

- **816f0108-0a02ffff : [PowerSupplyElementName] has returned to OK status. (Power Supply 2)**

This message is for the use case when an implementation has detected a Power Supply return to normal operational status.

May also be shown as 816f01080a02ffff or 0x816f01080a02ffff

Severity

Info

Serviceable

No

Automatically notify support

No

Alert Category

Critical - Power

SNMP Trap ID

4

CIM Information

Prefix: PLAT ID: 0087

User Response

No action; information only.

- **816f010c-2001ffff : Uncorrectable error recovery detected for [PhysicalMemoryElementName] on Subsystem [MemoryElementName]. (DIMM 1)**

This message is for the use case when an implementation has detected a Memory uncorrectable error recovery.

May also be shown as 816f010c2001ffff or 0x816f010c2001ffff

Severity

Info

Serviceable

No

Automatically notify support

No

Alert Category

Critical - Memory

SNMP Trap ID

41

CIM Information

Prefix: PLAT ID: 0139

User Response

No action; information only.

- **816f010c-2002ffff : Uncorrectable error recovery detected for [PhysicalMemoryElementName] on Subsystem [MemoryElementName]. (DIMM 2)**

This message is for the use case when an implementation has detected a Memory uncorrectable error recovery.

May also be shown as 816f010c2002ffff or 0x816f010c2002ffff

Severity

Info

Serviceable

No

Automatically notify support

No

Alert Category

Critical - Memory

SNMP Trap ID

41

CIM Information**Prefix: PLAT ID: 0139****User Response**

No action; information only.

- **816f010c-2003ffff : Uncorrectable error recovery detected for [PhysicalMemoryElementName] on Subsystem [MemoryElementName]. (DIMM 3)**

This message is for the use case when an implementation has detected a Memory uncorrectable error recovery.

May also be shown as 816f010c2003ffff or 0x816f010c2003ffff

Severity

Info

Serviceable

No

Automatically notify support

No

Alert Category

Critical - Memory

SNMP Trap ID

41

CIM Information**Prefix: PLAT ID: 0139****User Response**

No action; information only.

- **816f010c-2004ffff : Uncorrectable error recovery detected for [PhysicalMemoryElementName] on Subsystem [MemoryElementName]. (DIMM 4)**

This message is for the use case when an implementation has detected a Memory uncorrectable error recovery.

May also be shown as 816f010c2004ffff or 0x816f010c2004ffff

Severity

Info

Serviceable

No

Automatically notify support

No

Alert Category

Critical - Memory

SNMP Trap ID

41

CIM Information**Prefix: PLAT ID: 0139****User Response**

No action; information only.

- **816f010c-2581ffff : Uncorrectable error recovery detected for [PhysicalMemoryElementName] on Subsystem [MemoryElementName]. (All DIMMS)**

This message is for the use case when an implementation has detected a Memory uncorrectable error recovery.

May also be shown as 816f010c2581ffff or 0x816f010c2581ffff

Severity

Info

Serviceable

No

Automatically notify support

No

Alert Category

Critical - Memory

SNMP Trap ID

41

CIM Information**Prefix: PLAT ID: 0139****User Response**

No action; information only. One of the DIMMs :

- **816f010d-0400ffff : The Drive [StorageVolumeElementName] has been enabled. (Drive 0)**

This message is for the use case when an implementation has detected a Drive was Enabled.

May also be shown as 816f010d0400ffff or 0x816f010d0400ffff

Severity

Info

Serviceable

No

Automatically notify support

No

Alert Category

Critical - Hard Disk drive

SNMP Trap ID

5

CIM Information

Prefix: PLAT ID: 0167

User Response

No action; information only.

- **816f010d-0401ffff : The Drive [StorageVolumeElementName] has been enabled. (Drive 1)**

This message is for the use case when an implementation has detected a Drive was Enabled.

May also be shown as 816f010d0401ffff or 0x816f010d0401ffff

Severity

Info

Serviceable

No

Automatically notify support

No

Alert Category

Critical - Hard Disk drive

SNMP Trap ID

5

CIM Information

Prefix: PLAT ID: 0167

User Response

No action; information only.

- **816f010d-0402ffff : The Drive [StorageVolumeElementName] has been enabled. (Drive 2)**

This message is for the use case when an implementation has detected a Drive was Enabled.

May also be shown as 816f010d0402ffff or 0x816f010d0402ffff

Severity

Info

Serviceable

No

Automatically notify support

No

Alert Category

Critical - Hard Disk drive

SNMP Trap ID

5

CIM Information

Prefix: PLAT ID: 0167

User Response

No action; information only.

- **816f010d-0403ffff : The Drive [StorageVolumeElementName] has been enabled. (Drive 3)**

This message is for the use case when an implementation has detected a Drive was Enabled.

May also be shown as 816f010d0403ffff or 0x816f010d0403ffff

Severity

Info

Serviceable

No

Automatically notify support

No

Alert Category

Critical - Hard Disk drive

SNMP Trap ID

5

CIM Information

Prefix: PLAT ID: 0167

User Response

No action; information only.

- **816f010d-0404ffff : The Drive [StorageVolumeElementName] has been enabled. (Drive 4)**

This message is for the use case when an implementation has detected a Drive was Enabled.

May also be shown as 816f010d0404ffff or 0x816f010d0404ffff

Severity

Info

Serviceable

No

Automatically notify support

No

Alert Category

Critical - Hard Disk drive

SNMP Trap ID

5

CIM Information

Prefix: PLAT ID: 0167

User Response

No action; information only.

- **816f010d-0405ffff : The Drive [StorageVolumeElementName] has been enabled. (Drive 5)**

This message is for the use case when an implementation has detected a Drive was Enabled.

May also be shown as 816f010d0405ffff or 0x816f010d0405ffff

Severity

Info

Serviceable

No

Automatically notify support

No

Alert Category

Critical - Hard Disk drive

SNMP Trap ID

5

CIM Information

Prefix: PLAT ID: 0167

User Response

No action; information only.

- **816f010d-0406ffff : The Drive [StorageVolumeElementName] has been enabled. (Drive 6)**

This message is for the use case when an implementation has detected a Drive was Enabled.

May also be shown as 816f010d0406ffff or 0x816f010d0406ffff

Severity

Info

Serviceable

No

Automatically notify support

No

Alert Category

Critical - Hard Disk drive

SNMP Trap ID

5

CIM Information

Prefix: PLAT ID: 0167

User Response

No action; information only.

- **816f010d-0407ffff : The Drive [StorageVolumeElementName] has been enabled. (Drive 7)**

This message is for the use case when an implementation has detected a Drive was Enabled.

May also be shown as 816f010d0407ffff or 0x816f010d0407ffff

Severity

Info

Serviceable

No

Automatically notify support

No

Alert Category

Critical - Hard Disk drive

SNMP Trap ID

5

CIM Information

Prefix: PLAT ID: 0167

User Response

No action; information only.

- **816f010d-0410ffff : The Drive [StorageVolumeElementName] has been enabled. (Ext Drive)**

This message is for the use case when an implementation has detected a Drive was Enabled.

May also be shown as 816f010d0410ffff or 0x816f010d0410ffff

Severity

Info

Serviceable

No

Automatically notify support

No

Alert Category

Critical - Hard Disk drive

SNMP Trap ID

CIM Information**Prefix:** PLAT ID: 0167**User Response**

No action; information only.

- **816f010f-2201ffff : The System [ComputerSystemElementName] has recovered from a firmware hang. (Firmware Error)**

This message is for the use case when an implementation has recovered from a System Firmware Hang.

May also be shown as 816f010f2201ffff or 0x816f010f2201ffff

Severity

Info

Serviceable

No

Automatically notify support

No

Alert Category

Critical - Other

SNMP Trap ID

50

CIM Information**Prefix:** PLAT ID: 0187**User Response**

No action; information only.

- **816f0125-1001ffff : [ManagedElementName] detected as present. (PCI Riser 1)**

This message is for the use case when an implementation has detected a Managed Element is now Present.

May also be shown as 816f01251001ffff or 0x816f01251001ffff

Severity

Info

Serviceable

No

Automatically notify support

No

Alert Category

System - Other

SNMP Trap ID

CIM Information

Prefix: PLAT ID: 0390

User Response

No action; information only.

- **816f0207-0301ffff : [ProcessorElementName] has Recovered from FRB1/BIST condition. (CPU 1)**

This message is for the use case when an implementation has detected a Processor Recovered - FRB1/BIST condition.

May also be shown as 816f02070301ffff or 0x816f02070301ffff

Severity

Info

Serviceable

No

Automatically notify support

No

Alert Category

Critical - CPU

SNMP Trap ID

40

CIM Information

Prefix: PLAT ID: 0045

User Response

No action; information only.

- **816f020d-0400ffff : Failure no longer Predicted on drive [StorageVolumeElementName] for array [ComputerSystemElementName]. (Drive 0)**

This message is for the use case when an implementation has detected an Array Failure is no longer Predicted.

May also be shown as 816f020d0400ffff or 0x816f020d0400ffff

Severity

Info

Serviceable

No

Automatically notify support

No

Alert Category

System - Predicted Failure

SNMP Trap ID

27

CIM Information

Prefix: PLAT ID: 0169

User Response

No action; information only.

- **816f020d-0401ffff : Failure no longer Predicted on drive [StorageVolumeElementName] for array [ComputerSystemElementName]. (Drive 1)**

This message is for the use case when an implementation has detected an Array Failure is no longer Predicted.

May also be shown as 816f020d0401ffff or 0x816f020d0401ffff

Severity

Info

Serviceable

No

Automatically notify support

No

Alert Category

System - Predicted Failure

SNMP Trap ID

27

CIM Information

Prefix: PLAT ID: 0169

User Response

No action; information only.

- **816f020d-0402ffff : Failure no longer Predicted on drive [StorageVolumeElementName] for array [ComputerSystemElementName]. (Drive 2)**

This message is for the use case when an implementation has detected an Array Failure is no longer Predicted.

May also be shown as 816f020d0402ffff or 0x816f020d0402ffff

Severity

Info

Serviceable

No

Automatically notify support

No

Alert Category

System - Predicted Failure

SNMP Trap ID

CIM Information

Prefix: PLAT ID: 0169

User Response

No action; information only.

- **816f020d-0403ffff : Failure no longer Predicted on drive [StorageVolumeElementName] for array [ComputerSystemElementName]. (Drive 3)**

This message is for the use case when an implementation has detected an Array Failure is no longer Predicted.

May also be shown as 816f020d0403ffff or 0x816f020d0403ffff

Severity

Info

Serviceable

No

Automatically notify support

No

Alert Category

System - Predicted Failure

SNMP Trap ID

27

CIM Information

Prefix: PLAT ID: 0169

User Response

No action; information only.

- **816f020d-0404ffff : Failure no longer Predicted on drive [StorageVolumeElementName] for array [ComputerSystemElementName]. (Drive 4)**

This message is for the use case when an implementation has detected an Array Failure is no longer Predicted.

May also be shown as 816f020d0404ffff or 0x816f020d0404ffff

Severity

Info

Serviceable

No

Automatically notify support

No

Alert Category

System - Predicted Failure

SNMP Trap ID

27

CIM Information

Prefix: PLAT ID: 0169

User Response

No action; information only.

- **816f020d-0405ffff : Failure no longer Predicted on drive [StorageVolumeElementName] for array [ComputerSystemElementName]. (Drive 5)**

This message is for the use case when an implementation has detected an Array Failure is no longer Predicted.

May also be shown as 816f020d0405ffff or 0x816f020d0405ffff

Severity

Info

Serviceable

No

Automatically notify support

No

Alert Category

System - Predicted Failure

SNMP Trap ID

27

CIM Information

Prefix: PLAT ID: 0169

User Response

No action; information only.

- **816f020d-0406ffff : Failure no longer Predicted on drive [StorageVolumeElementName] for array [ComputerSystemElementName]. (Drive 6)**

This message is for the use case when an implementation has detected an Array Failure is no longer Predicted.

May also be shown as 816f020d0406ffff or 0x816f020d0406ffff

Severity

Info

Serviceable

No

Automatically notify support

No

Alert Category

System - Predicted Failure

SNMP Trap ID

27

CIM Information

Prefix: PLAT ID: 0169

User Response

No action; information only.

- **816f020d-0407ffff : Failure no longer Predicted on drive [StorageVolumeElementName] for array [ComputerSystemElementName]. (Drive 7)**

This message is for the use case when an implementation has detected an Array Failure is no longer Predicted.

May also be shown as 816f020d0407ffff or 0x816f020d0407ffff

Severity

Info

Serviceable

No

Automatically notify support

No

Alert Category

System - Predicted Failure

SNMP Trap ID

27

CIM Information

Prefix: PLAT ID: 0169

User Response

No action; information only.

- **816f020d-0410ffff : Failure no longer Predicted on drive [StorageVolumeElementName] for array [ComputerSystemElementName]. (Ext Drive)**

This message is for the use case when an implementation has detected an Array Failure is no longer Predicted.

May also be shown as 816f020d0410ffff or 0x816f020d0410ffff

Severity

Info

Serviceable

No

Automatically notify support

No

Alert Category

System - Predicted Failure

SNMP Trap ID

27

CIM Information

Prefix: PLAT ID: 0169

User Response

No action; information only.

- **816f0308-0a01ffff : [PowerSupplyElementName] has returned to a Normal Input State. (Power Supply 1)**

This message is for the use case when an implementation has detected a Power Supply that has input that has returned to normal.

May also be shown as 816f03080a01ffff or 0x816f03080a01ffff

Severity

Info

Serviceable

No

Automatically notify support

No

Alert Category

System - Other

SNMP Trap ID**CIM Information**

Prefix: PLAT ID: 0099

User Response

No action; information only.

- **816f0308-0a02ffff : [PowerSupplyElementName] has returned to a Normal Input State. (Power Supply 2)**

This message is for the use case when an implementation has detected a Power Supply that has input that has returned to normal.

May also be shown as 816f03080a02ffff or 0x816f03080a02ffff

Severity

Info

Serviceable

No

Automatically notify support

No

Alert Category

System - Other

SNMP Trap ID

CIM Information

Prefix: PLAT ID: 0099

User Response

No action; information only.

- **816f030c-2001ffff : Scrub Failure for [PhysicalMemoryElementName] on Subsystem [MemoryElementName] has recovered. (DIMM 1)**

This message is for the use case when an implementation has detected a Memory Scrub failure recovery.

May also be shown as 816f030c2001ffff or 0x816f030c2001ffff

Severity

Info

Serviceable

No

Automatically notify support

No

Alert Category

Critical - Memory

SNMP Trap ID

41

CIM Information

Prefix: PLAT ID: 0137

User Response

No action; information only.

- **816f030c-2002ffff : Scrub Failure for [PhysicalMemoryElementName] on Subsystem [MemoryElementName] has recovered. (DIMM 2)**

This message is for the use case when an implementation has detected a Memory Scrub failure recovery.

May also be shown as 816f030c2002ffff or 0x816f030c2002ffff

Severity

Info

Serviceable

No

Automatically notify support

No

Alert Category

Critical - Memory

SNMP Trap ID

41

CIM Information

Prefix: PLAT ID: 0137

User Response

No action; information only.

- **816f030c-2003ffff : Scrub Failure for [PhysicalMemoryElementName] on Subsystem [MemoryElementName] has recovered. (DIMM 3)**

This message is for the use case when an implementation has detected a Memory Scrub failure recovery.

May also be shown as 816f030c2003ffff or 0x816f030c2003ffff

Severity

Info

Serviceable

No

Automatically notify support

No

Alert Category

Critical - Memory

SNMP Trap ID

41

CIM Information

Prefix: PLAT ID: 0137

User Response

No action; information only.

- **816f030c-2004ffff : Scrub Failure for [PhysicalMemoryElementName] on Subsystem [MemoryElementName] has recovered. (DIMM 4)**

This message is for the use case when an implementation has detected a Memory Scrub failure recovery.

May also be shown as 816f030c2004ffff or 0x816f030c2004ffff

Severity

Info

Serviceable

No

Automatically notify support

No

Alert Category

Critical - Memory

SNMP Trap ID

41

CIM Information

Prefix: PLAT ID: 0137

User Response

No action; information only.

- **816f030c-2581ffff : Scrub Failure for [PhysicalMemoryElementName] on Subsystem [MemoryElementName] has recovered. (All DIMMS)**

This message is for the use case when an implementation has detected a Memory Scrub failure recovery.

May also be shown as 816f030c2581ffff or 0x816f030c2581ffff

Severity

Info

Serviceable

No

Automatically notify support

No

Alert Category

Critical - Memory

SNMP Trap ID

41

CIM Information

Prefix: PLAT ID: 0137

User Response

No action; information only. One of the DIMMs :

- **816f030d-0400ffff : Hot spare disabled for [ComputerSystemElementName]. (Drive 0)**

This message is for the use case when an implementation has detected a Hot Spare has been Disabled.

May also be shown as 816f030d0400ffff or 0x816f030d0400ffff

Severity

Info

Serviceable

No

Automatically notify support

No

Alert Category

System - Other

SNMP Trap ID

CIM Information

Prefix: PLAT ID: 0171

User Response

No action; information only.

- **816f030d-0401ffff : Hot spare disabled for [ComputerSystemElementName]. (Drive 1)**

This message is for the use case when an implementation has detected a Hot Spare has been Disabled.

May also be shown as 816f030d0401ffff or 0x816f030d0401ffff

Severity

Info

Serviceable

No

Automatically notify support

No

Alert Category

System - Other

SNMP Trap ID

CIM Information

Prefix: PLAT ID: 0171

User Response

No action; information only.

- **816f030d-0402ffff : Hot spare disabled for [ComputerSystemElementName]. (Drive 2)**

This message is for the use case when an implementation has detected a Hot Spare has been Disabled.

May also be shown as 816f030d0402ffff or 0x816f030d0402ffff

Severity

Info

Serviceable

No

Automatically notify support

No

Alert Category

System - Other

SNMP Trap ID

CIM Information

Prefix: PLAT ID: 0171

User Response

No action; information only.

- **816f030d-0403ffff : Hot spare disabled for [ComputerSystemElementName]. (Drive 3)**

This message is for the use case when an implementation has detected a Hot Spare has been Disabled.

May also be shown as 816f030d0403ffff or 0x816f030d0403ffff

Severity

Info

Serviceable

No

Automatically notify support

No

Alert Category

System - Other

SNMP Trap ID**CIM Information**

Prefix: PLAT ID: 0171

User Response

No action; information only.

- **816f030d-0404ffff : Hot spare disabled for [ComputerSystemElementName]. (Drive 4)**

This message is for the use case when an implementation has detected a Hot Spare has been Disabled.

May also be shown as 816f030d0404ffff or 0x816f030d0404ffff

Severity

Info

Serviceable

No

Automatically notify support

No

Alert Category

System - Other

SNMP Trap ID**CIM Information**

Prefix: PLAT ID: 0171

User Response

No action; information only.

- **816f030d-0405ffff : Hot spare disabled for [ComputerSystemElementName]. (Drive 5)**

This message is for the use case when an implementation has detected a Hot Spare has been Disabled.

May also be shown as 816f030d0405ffff or 0x816f030d0405ffff

Severity

Info

Serviceable

No

Automatically notify support

No

Alert Category

System - Other

SNMP Trap ID**CIM Information**

Prefix: PLAT ID: 0171

User Response

No action; information only.

- **816f030d-0406ffff : Hot spare disabled for [ComputerSystemElementName]. (Drive 6)**

This message is for the use case when an implementation has detected a Hot Spare has been Disabled.

May also be shown as 816f030d0406ffff or 0x816f030d0406ffff

Severity

Info

Serviceable

No

Automatically notify support

No

Alert Category

System - Other

SNMP Trap ID**CIM Information**

Prefix: PLAT ID: 0171

User Response

No action; information only.

- **816f030d-0407ffff : Hot spare disabled for [ComputerSystemElementName]. (Drive 7)**

This message is for the use case when an implementation has detected a Hot Spare has been Disabled.

May also be shown as 816f030d0407ffff or 0x816f030d0407ffff

Severity

Info

Serviceable

No

Automatically notify support

No

Alert Category

System - Other

SNMP Trap ID

CIM Information

Prefix: PLAT ID: 0171

User Response

No action; information only.

- **816f030d-0410ffff : Hot spare disabled for [ComputerSystemElementName]. (Ext Drive)**

This message is for the use case when an implementation has detected a Hot Spare has been Disabled.

May also be shown as 816f030d0410ffff or 0x816f030d0410ffff

Severity

Info

Serviceable

No

Automatically notify support

No

Alert Category

System - Other

SNMP Trap ID

CIM Information

Prefix: PLAT ID: 0171

User Response

No action; information only.

- **816f0313-1701ffff : System [ComputerSystemElementName] has recovered from an NMI. (NMI State)**

This message is for the use case when an implementation has detected a Software NMI has been Recovered from.

May also be shown as 816f03131701ffff or 0x816f03131701ffff

Severity

Info

Serviceable

No

Automatically notify support

No

Alert Category

Critical - Other

SNMP Trap ID

50

CIM Information

Prefix: PLAT **ID:** 0230

User Response

No action; information only.

- **816f040c-2001ffff : [PhysicalMemoryElementName] Enabled on Subsystem [MemoryElementName]. (DIMM 1)**

This message is for the use case when an implementation has detected that Memory has been Enabled.

May also be shown as 816f040c2001ffff or 0x816f040c2001ffff

Severity

Info

Serviceable

No

Automatically notify support

No

Alert Category

System - Other

SNMP Trap ID

CIM Information

Prefix: PLAT **ID:** 0130

User Response

No action; information only.

- **816f040c-2002ffff : [PhysicalMemoryElementName] Enabled on Subsystem [MemoryElementName]. (DIMM 2)**

This message is for the use case when an implementation has detected that Memory has been Enabled.
May also be shown as 816f040c2002ffff or 0x816f040c2002ffff

Severity

Info

Serviceable

No

Automatically notify support

No

Alert Category

System - Other

SNMP Trap ID

CIM Information

Prefix: PLAT ID: 0130

User Response

No action; information only.

- **816f040c-2003ffff : [PhysicalMemoryElementName] Enabled on Subsystem [MemoryElementName]. (DIMM 3)**

This message is for the use case when an implementation has detected that Memory has been Enabled.
May also be shown as 816f040c2003ffff or 0x816f040c2003ffff

Severity

Info

Serviceable

No

Automatically notify support

No

Alert Category

System - Other

SNMP Trap ID

CIM Information

Prefix: PLAT ID: 0130

User Response

No action; information only.

- **816f040c-2004ffff : [PhysicalMemoryElementName] Enabled on Subsystem [MemoryElementName]. (DIMM 4)**

This message is for the use case when an implementation has detected that Memory has been Enabled.

May also be shown as 816f040c2004ffff or 0x816f040c2004ffff

Severity

Info

Serviceable

No

Automatically notify support

No

Alert Category

System - Other

SNMP Trap ID

CIM Information

Prefix: PLAT ID: 0130

User Response

No action; information only.

- **816f040c-2581ffff : [PhysicalMemoryElementName] Enabled on Subsystem [MemoryElementName]. (All DIMMS)**

This message is for the use case when an implementation has detected that Memory has been Enabled.

May also be shown as 816f040c2581ffff or 0x816f040c2581ffff

Severity

Info

Serviceable

No

Automatically notify support

No

Alert Category

System - Other

SNMP Trap ID

CIM Information

Prefix: PLAT ID: 0130

User Response

No action; information only. One of the DIMMs :

- **816f0413-2582ffff : A PCI PERR recovery has occurred on system [ComputerSystemElementName]. (PCIs)**

This message is for the use case when an implementation has detected a PCI PERR recovered.

May also be shown as 816f04132582ffff or 0x816f04132582ffff

Severity

Info

Serviceable

No

Automatically notify support

No

Alert Category

Critical - Other

SNMP Trap ID

50

CIM Information

Prefix: PLAT ID: 0233

User Response

No action; information only.

- **816f0507-0301ffff : [ProcessorElementName] has Recovered from a Configuration Mismatch. (CPU 1)**

This message is for the use case when an implementation has Recovered from a Processor Configuration Mismatch.

May also be shown as 816f05070301ffff or 0x816f05070301ffff

Severity

Info

Serviceable

No

Automatically notify support

No

Alert Category

Critical - CPU

SNMP Trap ID

40

CIM Information

Prefix: PLAT ID: 0063

User Response

No action; information only.

- **816f050c-2001ffff : Memory Logging Limit Removed for [PhysicalMemoryElementName] on Subsystem [MemoryElementName]. (DIMM 1)**

This message is for the use case when an implementation has detected that the Memory Logging Limit has been Removed.

May also be shown as 816f050c2001ffff or 0x816f050c2001ffff

Severity

Info

Serviceable

No

Automatically notify support

No

Alert Category

Warning - Memory

SNMP Trap ID

43

CIM Information

Prefix: PLAT ID: 0145

User Response

No action; information only.

- **816f050c-2002ffff : Memory Logging Limit Removed for [PhysicalMemoryElementName] on Subsystem [MemoryElementName]. (DIMM 2)**

This message is for the use case when an implementation has detected that the Memory Logging Limit has been Removed.

May also be shown as 816f050c2002ffff or 0x816f050c2002ffff

Severity

Info

Serviceable

No

Automatically notify support

No

Alert Category

Warning - Memory

SNMP Trap ID

43

CIM Information

Prefix: PLAT ID: 0145

User Response

No action; information only.

- **816f050c-2003ffff : Memory Logging Limit Removed for [PhysicalMemoryElementName] on Subsystem [MemoryElementName]. (DIMM 3)**

This message is for the use case when an implementation has detected that the Memory Logging Limit has been Removed.

May also be shown as 816f050c2003ffff or 0x816f050c2003ffff

Severity

Info

Serviceable

No

Automatically notify support

No

Alert Category

Warning - Memory

SNMP Trap ID

43

CIM Information

Prefix: PLAT ID: 0145

User Response

No action; information only.

- **816f050c-2004ffff : Memory Logging Limit Removed for [PhysicalMemoryElementName] on Subsystem [MemoryElementName]. (DIMM 4)**

This message is for the use case when an implementation has detected that the Memory Logging Limit has been Removed.

May also be shown as 816f050c2004ffff or 0x816f050c2004ffff

Severity

Info

Serviceable

No

Automatically notify support

No

Alert Category

Warning - Memory

SNMP Trap ID

43

CIM Information

Prefix: PLAT ID: 0145

User Response

No action; information only.

- **816f050c-2581ffff : Memory Logging Limit Removed for [PhysicalMemoryElementName] on Subsystem [MemoryElementName]. (All DIMMS)**

This message is for the use case when an implementation has detected that the Memory Logging Limit has been Removed.

May also be shown as 816f050c2581ffff or 0x816f050c2581ffff

Severity

Info

Serviceable

No

Automatically notify support

No

Alert Category

Warning - Memory

SNMP Trap ID

43

CIM Information

Prefix: PLAT ID: 0145

User Response

No action; information only. One of the DIMMs :

- **816f050d-0400ffff : Critical Array [ComputerSystemElementName] has deasserted. (Drive 0)**

This message is for the use case when an implementation has detected that an Critical Array has deasserted.

May also be shown as 816f050d0400ffff or 0x816f050d0400ffff

Severity

Info

Serviceable

No

Automatically notify support

No

Alert Category

Critical - Hard Disk drive

SNMP Trap ID

5

CIM Information

Prefix: PLAT ID: 0175

User Response

No action; information only.

- **816f050d-0401ffff : Critical Array [ComputerSystemElementName] has deasserted. (Drive 1)**

This message is for the use case when an implementation has detected that an Critical Array has deasserted.

May also be shown as 816f050d0401ffff or 0x816f050d0401ffff

Severity

Info

Serviceable

No

Automatically notify support

No

Alert Category

Critical - Hard Disk drive

SNMP Trap ID

5

CIM Information

Prefix: PLAT ID: 0175

User Response

No action; information only.

- **816f050d-0402ffff : Critical Array [ComputerSystemElementName] has deasserted. (Drive 2)**

This message is for the use case when an implementation has detected that an Critical Array has deasserted.

May also be shown as 816f050d0402ffff or 0x816f050d0402ffff

Severity

Info

Serviceable

No

Automatically notify support

No

Alert Category

Critical - Hard Disk drive

SNMP Trap ID

5

CIM Information

Prefix: PLAT ID: 0175

User Response

No action; information only.

- **816f050d-0403ffff : Critical Array [ComputerSystemElementName] has deasserted. (Drive 3)**

This message is for the use case when an implementation has detected that an Critical Array has deasserted.

May also be shown as 816f050d0403ffff or 0x816f050d0403ffff

Severity

Info

Serviceable

No

Automatically notify support

No

Alert Category

Critical - Hard Disk drive

SNMP Trap ID

5

CIM Information

Prefix: PLAT **ID:** 0175

User Response

No action; information only.

- **816f050d-0404ffff : Critical Array [ComputerSystemElementName] has deasserted. (Drive 4)**

This message is for the use case when an implementation has detected that an Critical Array has deasserted.

May also be shown as 816f050d0404ffff or 0x816f050d0404ffff

Severity

Info

Serviceable

No

Automatically notify support

No

Alert Category

Critical - Hard Disk drive

SNMP Trap ID

5

CIM Information

Prefix: PLAT **ID:** 0175

User Response

No action; information only.

- **816f050d-0405ffff : Critical Array [ComputerSystemElementName] has deasserted. (Drive 5)**

This message is for the use case when an implementation has detected that an Critical Array has deasserted.

May also be shown as 816f050d0405ffff or 0x816f050d0405ffff

Severity

Info

Serviceable

No

Automatically notify support

No

Alert Category

Critical - Hard Disk drive

SNMP Trap ID

5

CIM Information

Prefix: PLAT ID: 0175

User Response

No action; information only.

- **816f050d-0406ffff : Critical Array [ComputerSystemElementName] has deasserted. (Drive 6)**

This message is for the use case when an implementation has detected that an Critical Array has deasserted.

May also be shown as 816f050d0406ffff or 0x816f050d0406ffff

Severity

Info

Serviceable

No

Automatically notify support

No

Alert Category

Critical - Hard Disk drive

SNMP Trap ID

5

CIM Information

Prefix: PLAT ID: 0175

User Response

No action; information only.

- **816f050d-0407ffff : Critical Array [ComputerSystemElementName] has deasserted. (Drive 7)**

This message is for the use case when an implementation has detected that an Critical Array has deasserted.

May also be shown as 816f050d0407ffff or 0x816f050d0407ffff

Severity

Info

Serviceable

No

Automatically notify support

No

Alert Category

Critical - Hard Disk drive

SNMP Trap ID

5

CIM Information

Prefix: PLAT ID: 0175

User Response

No action; information only.

- **816f050d-0410ffff : Critical Array [ComputerSystemElementName] has deasserted. (Ext Drive)**

This message is for the use case when an implementation has detected that an Critical Array has deasserted.

May also be shown as 816f050d0410ffff or 0x816f050d0410ffff

Severity

Info

Serviceable

No

Automatically notify support

No

Alert Category

Critical - Hard Disk drive

SNMP Trap ID

5

CIM Information

Prefix: PLAT ID: 0175

User Response

No action; information only.

- **816f0513-2582ffff : A PCI SERR on system [ComputerSystemElementName] has deasserted. (PCIs)**

This message is for the use case when an implementation has detected a PCI SERR deassertion.

May also be shown as 816f05132582ffff or 0x816f05132582ffff

Severity

Info

Serviceable

No

Automatically notify support

No

Alert Category

Critical - Other

SNMP Trap ID

50

CIM Information

Prefix: PLAT ID: 0235

User Response

No action; information only.

- **816f0607-0301ffff : An SM BIOS Uncorrectable CPU complex error for [ProcessorElementName] has deasserted. (CPU 1)**

This message is for the use case when an SM BIOS Uncorrectable CPU complex error has deasserted.

May also be shown as 816f06070301ffff or 0x816f06070301ffff

Severity

Info

Serviceable

No

Automatically notify support

No

Alert Category

Critical - CPU

SNMP Trap ID

40

CIM Information

Prefix: PLAT ID: 0817

User Response

No action; information only.

- **816f060d-0400ffff : Array in system [ComputerSystemElementName] has been restored. (Drive 0)**

This message is for the use case when an implementation has detected that a Failed Array has been Restored.

May also be shown as 816f060d0400ffff or 0x816f060d0400ffff

Severity

Info

Serviceable

No

Automatically notify support

No

Alert Category

Critical - Hard Disk drive

SNMP Trap ID

5

CIM Information

Prefix: PLAT ID: 0177

User Response

No action; information only.

- **816f060d-0401ffff : Array in system [ComputerSystemElementName] has been restored. (Drive 1)**

This message is for the use case when an implementation has detected that a Failed Array has been Restored.

May also be shown as 816f060d0401ffff or 0x816f060d0401ffff

Severity

Info

Serviceable

No

Automatically notify support

No

Alert Category

Critical - Hard Disk drive

SNMP Trap ID

5

CIM Information

Prefix: PLAT ID: 0177

User Response

No action; information only.

- **816f060d-0402ffff : Array in system [ComputerSystemElementName] has been restored. (Drive 2)**

This message is for the use case when an implementation has detected that a Failed Array has been Restored.

May also be shown as 816f060d0402ffff or 0x816f060d0402ffff

Severity

Info

Serviceable

No

Automatically notify support

No

Alert Category

Critical - Hard Disk drive

SNMP Trap ID

5

CIM Information**Prefix:** PLAT ID: 0177**User Response**

No action; information only.

- **816f060d-0403ffff : Array in system [ComputerSystemElementName] has been restored. (Drive 3)**

This message is for the use case when an implementation has detected that a Failed Array has been Restored.

May also be shown as 816f060d0403ffff or 0x816f060d0403ffff

Severity

Info

Serviceable

No

Automatically notify support

No

Alert Category

Critical - Hard Disk drive

SNMP Trap ID

5

CIM Information**Prefix:** PLAT ID: 0177**User Response**

No action; information only.

- **816f060d-0404ffff : Array in system [ComputerSystemElementName] has been restored. (Drive 4)**

This message is for the use case when an implementation has detected that a Failed Array has been Restored.

May also be shown as 816f060d0404ffff or 0x816f060d0404ffff

Severity

Info

Serviceable

No

Automatically notify support

No

Alert Category

Critical - Hard Disk drive

SNMP Trap ID

5

CIM Information

Prefix: PLAT ID: 0177

User Response

No action; information only.

- **816f060d-0405ffff : Array in system [ComputerSystemElementName] has been restored. (Drive 5)**

This message is for the use case when an implementation has detected that a Failed Array has been Restored.

May also be shown as 816f060d0405ffff or 0x816f060d0405ffff

Severity

Info

Serviceable

No

Automatically notify support

No

Alert Category

Critical - Hard Disk drive

SNMP Trap ID

5

CIM Information

Prefix: PLAT ID: 0177

User Response

No action; information only.

- **816f060d-0406ffff : Array in system [ComputerSystemElementName] has been restored. (Drive 6)**

This message is for the use case when an implementation has detected that a Failed Array has been Restored.

May also be shown as 816f060d0406ffff or 0x816f060d0406ffff

Severity

Info

Serviceable

No

Automatically notify support

No

Alert Category

Critical - Hard Disk drive

SNMP Trap ID

5

CIM Information

Prefix: PLAT ID: 0177

User Response

No action; information only.

- **816f060d-0407ffff : Array in system [ComputerSystemElementName] has been restored. (Drive 7)**

This message is for the use case when an implementation has detected that a Failed Array has been Restored.

May also be shown as 816f060d0407ffff or 0x816f060d0407ffff

Severity

Info

Serviceable

No

Automatically notify support

No

Alert Category

Critical - Hard Disk drive

SNMP Trap ID

5

CIM Information

Prefix: PLAT ID: 0177

User Response

No action; information only.

- **816f060d-0410ffff : Array in system [ComputerSystemElementName] has been restored. (Ext Drive)**

This message is for the use case when an implementation has detected that a Failed Array has been Restored.

May also be shown as 816f060d0410ffff or 0x816f060d0410ffff

Severity

Info

Serviceable

No

Automatically notify support

No

Alert Category

Critical - Hard Disk drive

SNMP Trap ID

5

CIM Information

Prefix: PLAT ID: 0177

User Response

No action; information only.

- **816f070c-2001ffff : Configuration error for [PhysicalMemoryElementName] on Subsystem [MemoryElementName]has deasserted. (DIMM 1)**

This message is for the use case when an implementation has detected a Memory DIMM configuration error has deasserted.

May also be shown as 816f070c2001ffff or 0x816f070c2001ffff

Severity

Info

Serviceable

No

Automatically notify support

No

Alert Category

Critical - Memory

SNMP Trap ID

41

CIM Information

Prefix: PLAT ID: 0127

User Response

No action; information only.

- **816f070c-2002ffff : Configuration error for [PhysicalMemoryElementName] on Subsystem [MemoryElementName]has deasserted. (DIMM 2)**

This message is for the use case when an implementation has detected a Memory DIMM configuration error has deasserted.

May also be shown as 816f070c2002ffff or 0x816f070c2002ffff

Severity

Info

Serviceable

No

Automatically notify support

No

Alert Category

Critical - Memory

SNMP Trap ID

41

CIM Information

Prefix: PLAT ID: 0127

User Response

No action; information only.

- **816f070c-2003ffff : Configuration error for [PhysicalMemoryElementName] on Subsystem [MemoryElementName]has deasserted. (DIMM 3)**

This message is for the use case when an implementation has detected a Memory DIMM configuration error has deasserted.

May also be shown as 816f070c2003ffff or 0x816f070c2003ffff

Severity

Info

Serviceable

No

Automatically notify support

No

Alert Category

Critical - Memory

SNMP Trap ID

41

CIM Information

Prefix: PLAT ID: 0127

User Response

No action; information only.

- **816f070c-2004ffff : Configuration error for [PhysicalMemoryElementName] on Subsystem [MemoryElementName]has deasserted. (DIMM 4)**

This message is for the use case when an implementation has detected a Memory DIMM configuration error has deasserted.

May also be shown as 816f070c2004ffff or 0x816f070c2004ffff

Severity

Info

Serviceable

No

Automatically notify support

No

Alert Category

Critical - Memory

SNMP Trap ID

41

CIM Information

Prefix: PLAT ID: 0127

User Response

No action; information only.

- **816f070c-2581ffff : Configuration error for [PhysicalMemoryElementName] on Subsystem [MemoryElementName]has deasserted. (All DIMMS)**

This message is for the use case when an implementation has detected a Memory DIMM configuration error has deasserted.

May also be shown as 816f070c2581ffff or 0x816f070c2581ffff

Severity

Info

Serviceable

No

Automatically notify support

No

Alert Category

Critical - Memory

SNMP Trap ID

41

CIM Information

Prefix: PLAT ID: 0127

User Response

No action; information only. One of the DIMMs :

- **816f070d-0400ffff : Rebuild completed for Array in system [ComputerSystemElementName]. (Drive 0)**

This message is for the use case when an implementation has detected that an Array Rebuild has Completed.

May also be shown as 816f070d0400ffff or 0x816f070d0400ffff

Severity

Info

Serviceable

No

Automatically notify support

No

Alert Category

System - Other

SNMP Trap ID**CIM Information**

Prefix: PLAT ID: 0179

User Response

No action; information only.

- **816f070d-0401ffff : Rebuild completed for Array in system [ComputerSystemElementName]. (Drive 1)**

This message is for the use case when an implementation has detected that an Array Rebuild has Completed.

May also be shown as 816f070d0401ffff or 0x816f070d0401ffff

Severity

Info

Serviceable

No

Automatically notify support

No

Alert Category

System - Other

SNMP Trap ID**CIM Information**

Prefix: PLAT ID: 0179

User Response

No action; information only.

- **816f070d-0402ffff : Rebuild completed for Array in system [ComputerSystemElementName]. (Drive 2)**

This message is for the use case when an implementation has detected that an Array Rebuild has Completed.

May also be shown as 816f070d0402ffff or 0x816f070d0402ffff

Severity

Info

Serviceable

No

Automatically notify support

No

Alert Category

System - Other

SNMP Trap ID**CIM Information**

Prefix: PLAT ID: 0179

User Response

No action; information only.

- **816f070d-0403ffff : Rebuild completed for Array in system [ComputerSystemElementName]. (Drive 3)**

This message is for the use case when an implementation has detected that an Array Rebuild has Completed.

May also be shown as 816f070d0403ffff or 0x816f070d0403ffff

Severity

Info

Serviceable

No

Automatically notify support

No

Alert Category

System - Other

SNMP Trap ID**CIM Information**

Prefix: PLAT ID: 0179

User Response

No action; information only.

- **816f070d-0404ffff : Rebuild completed for Array in system [ComputerSystemElementName]. (Drive 4)**

This message is for the use case when an implementation has detected that an Array Rebuild has Completed.

May also be shown as 816f070d0404ffff or 0x816f070d0404ffff

Severity

Info

Serviceable

No

Automatically notify support

No

Alert Category

System - Other

SNMP Trap ID**CIM Information**

Prefix: PLAT ID: 0179

User Response

No action; information only.

- **816f070d-0405ffff : Rebuild completed for Array in system [ComputerSystemElementName]. (Drive 5)**

This message is for the use case when an implementation has detected that an Array Rebuild has Completed.

May also be shown as 816f070d0405ffff or 0x816f070d0405ffff

Severity

Info

Serviceable

No

Automatically notify support

No

Alert Category

System - Other

SNMP Trap ID**CIM Information**

Prefix: PLAT ID: 0179

User Response

No action; information only.

- **816f070d-0406ffff : Rebuild completed for Array in system [ComputerSystemElementName]. (Drive 6)**

This message is for the use case when an implementation has detected that an Array Rebuild has Completed.

May also be shown as 816f070d0406ffff or 0x816f070d0406ffff

Severity

Info

Serviceable

No

Automatically notify support

No

Alert Category

System - Other

SNMP Trap ID**CIM Information**

Prefix: PLAT ID: 0179

User Response

No action; information only.

- **816f070d-0407ffff : Rebuild completed for Array in system [ComputerSystemElementName]. (Drive 7)**

This message is for the use case when an implementation has detected that an Array Rebuild has Completed.

May also be shown as 816f070d0407ffff or 0x816f070d0407ffff

Severity

Info

Serviceable

No

Automatically notify support

No

Alert Category

System - Other

SNMP Trap ID**CIM Information**

Prefix: PLAT ID: 0179

User Response

No action; information only.

- **816f070d-0410ffff : Rebuild completed for Array in system [ComputerSystemElementName]. (Ext Drive)**

This message is for the use case when an implementation has detected that an Array Rebuild has Completed.

May also be shown as 816f070d0410ffff or 0x816f070d0410ffff

Severity

Info

Serviceable

No

Automatically notify support

No

Alert Category

System - Other

SNMP Trap ID**CIM Information**

Prefix: PLAT ID: 0179

User Response

No action; information only.

- **816f0807-0301ffff : [ProcessorElementName] has been Enabled. (CPU 1)**

This message is for the use case when an implementation has detected a Processor has been Enabled.

May also be shown as 816f08070301ffff or 0x816f08070301ffff

Severity

Info

Serviceable

No

Automatically notify support

No

Alert Category

System - Other

SNMP Trap ID**CIM Information**

Prefix: PLAT ID: 0060

User Response

No action; information only.

- **816f0813-2582ffff : System [ComputerSystemElementName] has recovered from an Uncorrectable Bus Error. (PCIs)**

This message is for the use case when an implementation has detected a that a system has recovered from a Bus Uncorrectable Error.

May also be shown as 816f08132582ffff or 0x816f08132582ffff

Severity

Info

Serviceable

No

Automatically notify support

No

Alert Category

Critical - Other

SNMP Trap ID

50

CIM Information

Prefix: PLAT ID: 0241

User Response

No action; information only.

- **816f0813-2584ffff : System [ComputerSystemElementName] has recovered from an Uncorrectable Bus Error. (CPUs)**

This message is for the use case when an implementation has detected a that a system has recovered from a Bus Uncorrectable Error.

May also be shown as 816f08132584ffff or 0x816f08132584ffff

Severity

Info

Serviceable

No

Automatically notify support

No

Alert Category

Critical - Other

SNMP Trap ID

50

CIM Information

Prefix: PLAT ID: 0241

User Response

No action; information only.

- **816f090c-2001ffff : [PhysicalMemoryElementName] on Subsystem [MemoryElementName] is no longer Throttled. (DIMM 1)**

This message is for the use case when an implementation has detected Memory is no longer Throttled.

May also be shown as 816f090c2001ffff or 0x816f090c2001ffff

Severity

Info

Serviceable

No

Automatically notify support

No

Alert Category

System - Other

SNMP Trap ID

CIM Information

Prefix: PLAT ID: 0143

User Response

No action; information only.

- **816f090c-2002ffff : [PhysicalMemoryElementName] on Subsystem [MemoryElementName] is no longer Throttled. (DIMM 2)**

This message is for the use case when an implementation has detected Memory is no longer Throttled.

May also be shown as 816f090c2002ffff or 0x816f090c2002ffff

Severity

Info

Serviceable

No

Automatically notify support

No

Alert Category

System - Other

SNMP Trap ID

CIM Information

Prefix: PLAT ID: 0143

User Response

No action; information only.

- **816f090c-2003ffff : [PhysicalMemoryElementName] on Subsystem [MemoryElementName] is no longer Throttled. (DIMM 3)**

This message is for the use case when an implementation has detected Memory is no longer Throttled.

May also be shown as 816f090c2003ffff or 0x816f090c2003ffff

Severity

Info

Serviceable

No

Automatically notify support

No

Alert Category

System - Other

SNMP Trap ID**CIM Information**

Prefix: PLAT ID: 0143

User Response

No action; information only.

- **816f090c-2004ffff : [PhysicalMemoryElementName] on Subsystem [MemoryElementName] is no longer Throttled. (DIMM 4)**

This message is for the use case when an implementation has detected Memory is no longer Throttled.

May also be shown as 816f090c2004ffff or 0x816f090c2004ffff

Severity

Info

Serviceable

No

Automatically notify support

No

Alert Category

System - Other

SNMP Trap ID**CIM Information**

Prefix: PLAT ID: 0143

User Response

No action; information only.

- **816f0a07-0301ffff : The Processor [ProcessorElementName] is no longer operating in a Degraded State. (CPU 1)**

This message is for the use case when an implementation has detected a Processor is no longer running in the Degraded state.

May also be shown as 816f0a070301ffff or 0x816f0a070301ffff

Severity

Info

Serviceable

No

Automatically notify support

No

Alert Category

Warning - CPU

SNMP Trap ID

42

CIM Information

Prefix: PLAT ID: 0039

User Response

No action; information only.

- **816f0a0c-2001ffff : An Over-Temperature Condition has been removed on the [PhysicalMemoryElementName] on Subsystem [MemoryElementName]. (DIMM 1)**

This message is for the use case when an implementation has detected an Over Temperature Condition for Memory that has been Removed.

May also be shown as 816f0a0c2001ffff or 0x816f0a0c2001ffff

Severity

Info

Serviceable

No

Automatically notify support

No

Alert Category

Critical - Temperature

SNMP Trap ID

0

CIM Information

Prefix: PLAT ID: 0147

User Response

No action; information only.

- **816f0a0c-2002ffff : An Over-Temperature Condition has been removed on the [PhysicalMemoryElementName] on Subsystem [MemoryElementName]. (DIMM 2)**

This message is for the use case when an implementation has detected an Over Temperature Condition for Memory that has been Removed.

May also be shown as 816f0a0c2002ffff or 0x816f0a0c2002ffff

Severity

Info

Serviceable

No

Automatically notify support

No

Alert Category

Critical - Temperature

SNMP Trap ID

0

CIM Information

Prefix: PLAT ID: 0147

User Response

No action; information only.

- **816f0a0c-2003ffff : An Over-Temperature Condition has been removed on the [PhysicalMemoryElementName] on Subsystem [MemoryElementName]. (DIMM 3)**

This message is for the use case when an implementation has detected an Over Temperature Condition for Memory that has been Removed.

May also be shown as 816f0a0c2003ffff or 0x816f0a0c2003ffff

Severity

Info

Serviceable

No

Automatically notify support

No

Alert Category

Critical - Temperature

SNMP Trap ID

0

CIM Information

Prefix: PLAT ID: 0147

User Response

No action; information only.

- **816f0a0c-2004ffff : An Over-Temperature Condition has been removed on the [PhysicalMemoryElementName] on Subsystem [MemoryElementName]. (DIMM 4)**

This message is for the use case when an implementation has detected an Over Temperature Condition for Memory that has been Removed.

May also be shown as 816f0a0c2004ffff or 0x816f0a0c2004ffff

Severity

Info

Serviceable

No

Automatically notify support

No

Alert Category

Critical - Temperature

SNMP Trap ID

0

CIM Information

Prefix: PLAT ID: 0147

User Response

No action; information only.

IMM Events that automatically notify Support

You can configure the Lenovo XClarity Administrator or the CMM to automatically notify Support (also known as *call home*) if certain types of errors are encountered. If you have configured this function, see the table for a list of events that automatically notify Support.

Table 28. Events that automatically notify Support

Event ID	Message String	Automatically Notify Support
40000086-00000000	Test Call Home Generated by user [arg1].	Yes
40000087-00000000	Manual Call Home by user [arg1]: [arg2].	Yes
400000cb-00000000	The RAID controller has problem with the battery. Please contact technical support to resolve this issue.([arg1],[arg2],[arg3],[arg4],[arg5])	Yes
400000cc-00000000	The RAID controller detected unrecoverable error. The controller needs replacement.([arg1],[arg2],[arg3],[arg4],[arg5])	Yes
400000d5-00000000	One or more virtual drive have problem. Please contact technical support to resolve this issue.([arg1],[arg2],[arg3],[arg4],[arg5])	Yes
400000d6-00000000	Drive error was detected by RAID controller. Please contact technical support to resolve this issue.([arg1],[arg2],[arg3],[arg4],[arg5])	Yes
80010202-0701ffff	Numeric sensor [NumericSensorElementName] going low (lower critical) has asserted. (CMOS Battery)	Yes
80010902-0701ffff	Numeric sensor [NumericSensorElementName] going high (upper critical) has asserted. (SysBrd 12V)	Yes
806f0021-2201ffff	Fault in slot [PhysicalConnectorSystemElementName] on system [ComputerSystemElementName]. (No Op ROM Space)	Yes

Table 28. Events that automatically notify Support (continued)

Event ID	Message String	Automatically Notify Support
806f0021-2582ffff	Fault in slot [PhysicalConnectorSystemElementName] on system [ComputerSystemElementName]. (All PCI Error)	Yes
806f0021-3001ffff	Fault in slot [PhysicalConnectorSystemElementName] on system [ComputerSystemElementName]. (PCI 1)	Yes
806f0021-3002ffff	Fault in slot [PhysicalConnectorSystemElementName] on system [ComputerSystemElementName]. (PCI 2)	Yes
806f0108-0a01ffff	[PowerSupplyElementName] has Failed. (Power Supply 1)	Yes
806f0108-0a02ffff	[PowerSupplyElementName] has Failed. (Power Supply 2)	Yes
806f010c-2001ffff	Uncorrectable error detected for [PhysicalMemoryElementName] on Subsystem [MemoryElementName]. (DIMM 1)	Yes
806f010c-2002ffff	Uncorrectable error detected for [PhysicalMemoryElementName] on Subsystem [MemoryElementName]. (DIMM 2)	Yes
806f010c-2003ffff	Uncorrectable error detected for [PhysicalMemoryElementName] on Subsystem [MemoryElementName]. (DIMM 3)	Yes
806f010c-2004ffff	Uncorrectable error detected for [PhysicalMemoryElementName] on Subsystem [MemoryElementName]. (DIMM 4)	Yes
806f010c-2581ffff	Uncorrectable error detected for [PhysicalMemoryElementName] on Subsystem [MemoryElementName]. (All DIMMS)	Yes
806f010d-0400ffff	The Drive [StorageVolumeElementName] has been disabled due to a detected fault. (Drive 0)	Yes
806f010d-0401ffff	The Drive [StorageVolumeElementName] has been disabled due to a detected fault. (Drive 1)	Yes
806f010d-0402ffff	The Drive [StorageVolumeElementName] has been disabled due to a detected fault. (Drive 2)	Yes
806f010d-0403ffff	The Drive [StorageVolumeElementName] has been disabled due to a detected fault. (Drive 3)	Yes
806f010d-0404ffff	The Drive [StorageVolumeElementName] has been disabled due to a detected fault. (Drive 4)	Yes
806f010d-0405ffff	The Drive [StorageVolumeElementName] has been disabled due to a detected fault. (Drive 5)	Yes
806f010d-0406ffff	The Drive [StorageVolumeElementName] has been disabled due to a detected fault. (Drive 6)	Yes
806f010d-0407ffff	The Drive [StorageVolumeElementName] has been disabled due to a detected fault. (Drive 7)	Yes
806f010d-0410ffff	The Drive [StorageVolumeElementName] has been disabled due to a detected fault. (Ext Drive)	Yes
806f0207-0301ffff	[ProcessorElementName] has Failed with FRB1/BIST condition. (CPU 1)	Yes
806f020d-0400ffff	Failure Predicted on drive [StorageVolumeElementName] for array [ComputerSystemElementName]. (Drive 0)	Yes

Table 28. Events that automatically notify Support (continued)

Event ID	Message String	Automatically Notify Support
806f020d-0401ffff	Failure Predicted on drive [StorageVolumeElementName] for array [ComputerSystemElementName]. (Drive 1)	Yes
806f020d-0402ffff	Failure Predicted on drive [StorageVolumeElementName] for array [ComputerSystemElementName]. (Drive 2)	Yes
806f020d-0403ffff	Failure Predicted on drive [StorageVolumeElementName] for array [ComputerSystemElementName]. (Drive 3)	Yes
806f020d-0404ffff	Failure Predicted on drive [StorageVolumeElementName] for array [ComputerSystemElementName]. (Drive 4)	Yes
806f020d-0405ffff	Failure Predicted on drive [StorageVolumeElementName] for array [ComputerSystemElementName]. (Drive 5)	Yes
806f020d-0406ffff	Failure Predicted on drive [StorageVolumeElementName] for array [ComputerSystemElementName]. (Drive 6)	Yes
806f020d-0407ffff	Failure Predicted on drive [StorageVolumeElementName] for array [ComputerSystemElementName]. (Drive 7)	Yes
806f020d-0410ffff	Failure Predicted on drive [StorageVolumeElementName] for array [ComputerSystemElementName]. (Ext Drive)	Yes
806f050c-2001ffff	Memory Logging Limit Reached for [PhysicalMemoryElementName] on Subsystem [MemoryElementName]. (DIMM 1)	Yes
806f050c-2002ffff	Memory Logging Limit Reached for [PhysicalMemoryElementName] on Subsystem [MemoryElementName]. (DIMM 2)	Yes
806f050c-2003ffff	Memory Logging Limit Reached for [PhysicalMemoryElementName] on Subsystem [MemoryElementName]. (DIMM 3)	Yes
806f050c-2004ffff	Memory Logging Limit Reached for [PhysicalMemoryElementName] on Subsystem [MemoryElementName]. (DIMM 4)	Yes
806f050c-2581ffff	Memory Logging Limit Reached for [PhysicalMemoryElementName] on Subsystem [MemoryElementName]. (All DIMMS)	Yes
806f060d-0400ffff	Array [ComputerSystemElementName] has failed. (Drive 0)	Yes
806f060d-0401ffff	Array [ComputerSystemElementName] has failed. (Drive 1)	Yes
806f060d-0402ffff	Array [ComputerSystemElementName] has failed. (Drive 2)	Yes
806f060d-0403ffff	Array [ComputerSystemElementName] has failed. (Drive 3)	Yes
806f060d-0404ffff	Array [ComputerSystemElementName] has failed. (Drive 4)	Yes
806f060d-0405ffff	Array [ComputerSystemElementName] has failed. (Drive 5)	Yes
806f060d-0406ffff	Array [ComputerSystemElementName] has failed. (Drive 6)	Yes

Table 28. Events that automatically notify Support (continued)

Event ID	Message String	Automatically Notify Support
806f060d-0407ffff	Array [ComputerSystemElementName] has failed. (Drive 7)	Yes
806f060d-0410ffff	Array [ComputerSystemElementName] has failed. (Ext Drive)	Yes
806f0813-2582ffff	An Uncorrectable Bus Error has occurred on system [ComputerSystemElementName]. (PCIs)	Yes
806f0813-2584ffff	An Uncorrectable Bus Error has occurred on system [ComputerSystemElementName]. (CPUs)	Yes

Appendix B. UEFI (POST) error codes

This section details the UEFI (POST) error codes.

UEFI (POST) diagnostic error codes can be generated when the server starts up or while the server is running. UEFI (POST) codes are logged in the IMM2 event log in the server.

For each event code, the following fields are displayed:

Event identifier

An identifier that uniquely identifies an event.

Event description

The logged message string that appears for an event.

Explanation

Additional information to explain why the event occurred.

Severity

An indication of the level of concern for the condition. The severity is abbreviated in the event log to the first character. The following severities can be displayed:

Table 29. Event severity levels

Severity	Description
Informational	An informational message is something that was recorded for audit purposes, usually a user action or a change of states that is normal behavior.
Warning	A warning is not as severe as an error, but if possible, the condition should be corrected before it becomes an error. It might also be a condition that requires additional monitoring or maintenance.
Error	An error typically indicates a failure or critical condition that impairs service or an expected function.

User response

Indicate the actions that you should take to resolve the event.

Perform the steps listed in this section in the order shown until the problem is solved. After you perform all of the actions that are described in this field, if you cannot solve the problem, contact IBM support.

The following is the list of the UEFI (POST) error codes and suggested actions to correct the detected problems.

List of UEFI events

This section lists all messages that can be sent from UEFI.

- **I.2018002 [I.2018002]**

Explanation: The device found at Bus % Device % Function % could not be configured due to resource constraints. The Vendor ID for the device is % and the Device ID is %. OUT_OF_RESOURCES (PCI Option ROM)

Severity

Info

User Response

Complete the following steps:

1. If this PCIe device and/or any attached cables were recently installed, moved, serviced or upgraded, reseal the adapter and any attached cables.
2. Check IBM support site for any applicable service bulletin or UEFI or adapter firmware update that applies to this error. NOTE: It may be necessary to disable unused option ROMs from UEFI F1 setup or Lenovo ToolsCenter Suite CLI or using adapter manufacturer utilities so that adapter firmware can be updated.
3. Move the adapter to a different slot. If a slot is not available or error recurs, replace the adapter.
4. If the adapter was moved to a different slot and the error did not recur, verify that this is not a system limitation. Then replace the system board. Also, if this is not the initial installation and the error persists after adapter replacement, replace the system board.

• I.2018003 [I.2018003]

Explanation: A bad option ROM checksum was detected for the device found at Bus % Device % Function %. The Vendor ID for the device is % and the Device ID is %. ROM CHECKSUM ERROR

Severity

Error

User Response

Complete the following steps:

1. If this PCIe device and/or any attached cables were recently installed, moved, serviced or upgraded, reseal the adapter and any attached cables.
2. Move the adapter to a different system slot, if available.
3. Check IBM support site for any applicable service bulletin or UEFI or adapter firmware update that applies to this error. NOTE: It may be necessary to configure slot to Gen1 or to use special utility software so that adapter firmware can be upgraded. Gen1/Gen2 settings can be configured via F1 Setup -> System Settings -> Devices and I/O Ports -> PCIe Gen1/Gen2/Gen3 Speed Selection, or the Lenovo ToolsCenter Suite CLI Utility.
4. Replace the adapter.

• I.3818001 [I.3818001]

Explanation: The firmware image capsule signature for the currently booted flash bank is invalid. Current Bank CRTM Capsule Update Signature Invalid

Severity

Info

User Response

Complete the following steps:

1. Reboot the system. Will come up on backup UEFI image. Update the primary UEFI image.
2. If error does not persist no additional recovery action is required.
3. If error persists, or boot is unsuccessful, replace the system board.

- **I.3818002 [I.3818002]**

Explanation: The firmware image capsule signature for the non-booted flash bank is invalid. Opposite Bank CRTM Capsule Update Signature Invalid

Severity

Info

User Response

Complete the following steps:

1. Update the backup UEFI image.
2. If error does not persist no additional recovery action is required.
3. If error persists, or boot is unsuccessful, replace the system board.

- **I.3818003 [I.3818003]**

Explanation: The CRTM flash driver could not lock the secure flash region. CRTM Could not lock secure flash region

Severity

Info

User Response

Complete the following steps:

1. If system failed to boot successfully, DC cycle the system.
2. If system boots to F1 setup, update the UEFI image and reset bank to primary (if required). If the system boots without error, recovery is complete and no additional action is required.
3. If system fails to boot, or if the firmware update attempt fails, replace the system board.

- **I.580A4 [I.580A4]**

Explanation: Memory population change detected. DIMM Population Change Detected

Severity

Info

User Response

Complete the following steps:

1. If you have added or removed DIMMs to the system, and no additional errors were detected, then please ignore this message.
2. Check system event log for uncorrected DIMM failures and replace those DIMMs.

- **S.2018001 [S.2018001]**

Explanation: An Uncorrected PCIe Error has Occurred at Bus % Device % Function %. The Vendor ID for the device is % and the Device ID is %. PCIe Uncorrected Error Detected

Severity

Error

User Response

Complete the following steps:

1. If this computer node and/or any attached cables were recently installed, moved, serviced or upgraded: a. Reseat the adapter and any attached cables. b. Reload device driver. c. If device is not recognized, reconfiguring slot to Gen1 or Gen2 may be required. Gen1/Gen2 settings can be configured via F1 Setup -> System Settings -> Devices and I/O Ports -> PCIe Gen1/Gen2/Gen3 Speed Selection, or the Lenovo ToolsCenter Suite CLI Utility.
2. Check the IBM support site for an applicable device driver, firmware update, or other information that applies to this error. Load the new device driver and install any required firmware updates.
3. If problem persists, remove the adapter. If system reboots successfully without the adapter, replace that adapter.
4. Replace the processor.

- **S.3020007 [S.3020007]**

Explanation: A firmware fault has been detected in the UEFI image. Internal UEFI Firmware Fault Detected, System halted

Severity

Error

User Response

Complete the following steps:

1. Check the IBM support site for an applicable service bulletin or firmware update that applies to this error.
2. Update the UEFI image.
3. Replace the system board.

- **S.3028002 [S.3028002]**

Explanation: Boot permission timeout detected. Boot Permission Negotiation Timeout

Severity

Error

User Response

Complete the following steps:

1. Check CMM/IMM logs for communication errors and resolve.
2. Reseat the system
3. If problem persists contact support

- **S.3030007 [S.3030007]**

Explanation: A firmware fault has been detected in the UEFI image. Internal UEFI Firmware Fault Detected, System halted

Severity

Error

User Response

Complete the following steps:

1. Check IBM support site for an applicable service bulletin or firmware update that applies to this error.
2. Update the UEFI image.
3. Replace the system board.

- **S.3040007 [S.3040007]**

Explanation: A firmware fault has been detected in the UEFI image. Internal UEFI Firmware Fault Detected, System halted

Severity

Error

User Response

Complete the following steps:

1. Check IBM support site for an applicable service bulletin or firmware update that applies to this error.
2. Update the UEFI image.
3. Replace the system board.

- **S.3050007 [S.3050007]**

Explanation: A firmware fault has been detected in the UEFI image. Internal UEFI Firmware Fault Detected, System halted

Severity

Error

User Response

Complete the following steps:

1. Check IBM support site for an applicable service bulletin or firmware update that applies to this error.
2. Update the UEFI image.
3. Replace the system board.

- **S.3060007 [S.3060007]**

Explanation: A firmware fault has been detected in the UEFI image. Internal UEFI Firmware Fault Detected, System halted

Severity

Error

User Response

Complete the following steps:

1. Check IBM support site for an applicable service bulletin or firmware update that applies to this error.
2. Update the UEFI image.
3. Replace the system board.

- **S.3070007 [S.3070007]**

Explanation: A firmware fault has been detected in the UEFI image. Internal UEFI Firmware Fault Detected, System halted

Severity

Error

User Response

Complete the following steps:

1. Check IBM support site for an applicable service bulletin or firmware update that applies to this error.
2. Update the UEFI image.
3. Replace the system board.

- **S.3108007 [S.3108007]**

Explanation:] The default system settings have been restored. System Configuration Restored to Defaults

Severity

Error

User Response

Complete the following steps:

1. Check IBM support site for an applicable service bulletin or firmware update that applies to this error.

- **S.3818004 [S.3818004]**

Explanation: The CRTM flash driver could not successfully flash the staging area. A failure occurred. CRTM Update Failed

Severity

Error

User Response

Complete the following steps:

1. Continue booting the system. If the system does not reset, manually reset the system.
2. If the error is not reported on the subsequent boot, no additional recovery action is required.
3. If the error persists, continue booting system and update the UEFI image.
4. Replace the system board.

- **S.3818007 [S.3818007]**

Explanation: The firmware image capsules for both flash banks could not be verified. CRTM image capsule could not be verified

Severity

Error

User Response

Complete the following steps:

1. If system failed to boot successfully, DC cycle system.
2. If system boots to F1 setup, update the UEFI image and reset bank to primary (if required). If the system boots without error, recovery is complete and no additional action is required.
3. If system fails to boot, or if the firmware update attempt fails, replace the system board.

- **S.51003 [S.51003]**

Explanation: An uncorrectable memory error was detected in DIMM slot % on rank %. [S.51003] An uncorrectable memory error was detected on processor % channel %. The failing DIMM within the channel could not be determined. [S.51003] An uncorrectable memory error has been detected. Fatal Memory Error Occurred

Severity

Error

User Response

Complete the following steps:

1. If the compute node has recently been installed, moved, serviced, or upgraded, verify that the DIMM is properly seated and visually verify that there is no foreign material in any DIMM connector on that memory channel. If either of these conditions is found, correct and retry with the same DIMM. (Note: The event Log might contain a recent 00580A4 event denoting detected change in DIMM population that could be related to this problem.)
2. If no problem is observed on the DIMM connectors or the problem persists, replace the DIMM identified by LightPath and/or event log entry.
3. If problem recurs on the same DIMM connector, replace the other DIMMs on the same memory channel.
4. Check the IBM support site for an applicable service bulletin or firmware update that applies to this memory error.
5. If problem recurs on the same DIMM connector, inspect connector for damage. If found, replace the system board.
6. Replace the affected processor.
7. Replace system board.

- **S.51006 [S.51006]**

Explanation: A memory mismatch has been detected. Please verify that the memory configuration is valid. One or More Mismatched DIMMs Detected

Severity

Error

User Response

Complete the following steps:

1. Could follow an uncorrectable memory error or failed memory test. Check the log and service that event first. DIMMs disabled by other errors or actions could cause this event.
2. Verify that the DIMMs are installed in the correct population sequence.

3. Disable memory mirroring and sparing. If this action eliminates the mismatch, check the IBM Support site for information related to this problem.
4. Update UEFI firmware.
5. Replace the DIMM.
6. Replace the processor.

- **S.51009 [S.51009]**

Explanation: No system memory has been detected. No Memory Detected

Severity

Error

User Response

Complete the following steps:

1. If any memory errors are logged other than this one, take actions indicated for those codes first.
2. If no other memory diagnostic codes appear in the logs, verify that all DIMM connectors are enabled using the Setup utility or Lenovo ToolsCenter Suite CLI Utility.
3. If the problem remains, shut down and remove node from chassis and physically verify that one or more DIMMs are installed and that all DIMMs are installed in the correct population sequence.
4. If DIMMs are present and properly installed, check for any lit DIMM-connector LEDs, and if found, reseat those DIMMs.
5. Reinstall node in chassis, power on node, then check logs for memory diagnostic codes.
6. If the problem remains, replace the processor.
7. If the problem remains, replace the system board.

- **S.58008 [S.58008]**

Explanation: A DIMM has failed the POST memory test. DIMM Failed Memory Test

Severity

Error

User Response

Complete the following steps:

1. You must AC-cycle the system to re-enable the affected DIMM connector or re-enable manually using the Setup utility.
2. If the compute node has been recently installed, serviced, moved, or upgraded, check to ensure that DIMMs are firmly seated and that no foreign material can be seen in the DIMM connector. If either condition is observed, correct and retry with the same DIMM. (Note: The event Log might contain a recent 00580A4 event denoting detected change in DIMM population that could be related to this problem.)
3. If problem persists, replace the DIMM identified by LightPath and/or event log entry.
4. If problem recurs on the same DIMM connector, swap the other DIMMs on the same memory channel across channels one at a time to a different memory channel or processor. If problem follows a moved DIMM to a different memory channel, replace that DIMM.
5. Check the IBM support site for an applicable service bulletin or firmware update that applies to this memory error.

6. If problem stays with the original DIMM connector, re-inspect DIMM connector for foreign material and remove, if found. If connector is damaged, replace system board.
7. Remove the affected processor and inspect the processor socket pins for damaged or mis-aligned pins. If damage is found, or this is an upgrade processor, replace the system board. If there are multiple processors, swap them to move affected processor to another processor socket and retry. If problem follows the affected processor (or there is only one processor), replace the affected processor.
8. Replace the system board.

- **S.68005 [S.68005]**

Explanation: An error has been detected by the I/O core logic on Bus %. The Global Fatal Error Status register contains %. The Global Non-Fatal Error Status register contains %. Please check error logs for the presence of additional downstream device error data. Critical IOH-PCI Error

Severity

Error

User Response

Complete the following steps:

1. Check the log for a separate error related to an associated PCIe device and resolve that error.
2. Check the IBM support site for an applicable service bulletin or firmware update for the system or adapter that applies to this error.
3. Replace the system board.

- **W.11004 [W.11004]**

Explanation: A processor within the system has failed the BIST. Processor Self Test Failure Detected

Severity

Error

User Response

Complete the following steps:

1. If the processor or firmware was just updated, check the IBM support site for an applicable service bulletin or firmware update that applies to this processor error.
2. If there are multiple processors, swap processors to move affected processor to another processor socket and retry. If problem follows the affected processor, or this is a single processor system, replace the processor. Inspect the processor socket on each processor removal and replace system board first if the processor socket is damaged or mis-aligned pins are found.
3. Replace the system board.

- **W.3818005 [W.3818005]**

Explanation: The CRTM flash driver could not successfully flash the staging area. The update was aborted CRTM Update Aborted

Severity

Warning

User Response

Complete the following steps:

1. Continue booting the system. If system does not reset, manually reset the system.
2. If the error is not reported on the subsequent boot, no additional recovery action is required.
3. If the event persists, continue booting system and update the UEFI image.
4. Replace the system board.

- **W.381800D [W.381800D]**

Explanation: TPM physical presence is in asserted state TPM physical presence is in asserted state

Severity

Warning

User Response

Complete the following steps:

1. Complete any administrative tasks requiring the TPM physical presence switch to be in the "ON" position.
2. Restore the physical presence switch to the "OFF" position and reboot the system.
3. Replace the system board.

- **W.50001 [W.50001]**

Explanation: A DIMM has been disabled due to an error detected during POST. DIMM Disabled

Severity

Info

User Response

Complete the following steps:

1. If the DIMM was disabled because of a memory fault, follow the procedure for that event.
2. If no memory fault is recorded in the logs and no DIMM connector error LEDs are lit, re-enable the DIMM through the Setup utility or Lenovo ToolsCenter Suite CLI Utility.
3. If the problem persists, Power cycle the compute node from the management console.
4. Reset the IMM to default settings.
5. Reset UEFI to default settings.
6. Update IMM and UEFI firmware.
7. Replace the system board.

- **W.58001 [W.58001]**

Explanation: The PFA Threshold limit (correctable error logging limit) has been exceeded on DIMM number % at address %. MC5 Status contains % and MC5 Misc contains %. DIMM PFA Threshold Exceeded

Severity

Error

User Response

Complete the following steps:

1. If the compute node has recently been installed, moved, serviced, or upgraded, verify that the DIMM is properly seated and visually verify that there is no foreign material in any DIMM connector on that memory channel. If either of these conditions is found, correct and retry with the same DIMM. (Note: The event Log might contain a recent 00580A4 event denoting detected change in DIMM population that could be related to this problem.)
2. Check the IBM support site for an applicable firmware update that applies to this memory error. The release notes will list the known problems the update addresses.
3. If the previous steps do not resolve the problem, at the next maintenance opportunity, replace the affected DIMM (as indicated by LightPath and/or failure log entry).
4. If PFA re-occurs on the same DIMM connector, swap the other DIMMs on the same memory channel one at a time to a different memory channel or processor. If PFA follows a moved DIMM to any DIMM connector on the different memory channel, replace the moved DIMM.
5. Check the IBM support site for an applicable Service Bulletins (Service bulletins) that applies to this memory error. (Link to IBM support service bulletins)
6. If problem continues to re-occur on the same DIMM connector, inspect DIMM connector for foreign material and remove, if found. If connector is damaged, replace system board.
7. Remove the affected processor and inspect the processor socket pins for damaged or mis-aligned pins. If damage is found or the processor is an upgrade part, replace the system board.
8. Replace affected processor.
9. Replace the system board.

- **W.68002 [W.68002]**

Explanation: A CMOS battery error has been detected CMOS Battery Fault

Severity

Error

User Response

Complete the following steps:

1. If the system was recently installed, moved, or serviced, make sure the battery is properly seated.
2. Check the IBM support site for an applicable service bulletin or firmware update that applies to this error.
3. Replace the CMOS battery.
4. Replace the system board.

Appendix C. DSA diagnostic test results

After running the DSA diagnostic tests, use this information to resolve any issues that were found.

DSA Broadcom network test results

The following messages can result when you run the Broadcom network test.

Test results for the DSA Broadcom network test

The following messages can result when you run the DSA Broadcom network test.

- **405-000-000 : BRCM:TestControlRegisters Test Passed**

The test passed.

Recoverable

No

Severity

Event

Serviceable

No

Automatically notify support

No

Related links

- IBM Support website
- Latest level of DSA
- Latest level of BMC/IMM

- **405-001-000 : BRCM:TestMIIRegisters Test Passed**

The test passed.

Recoverable

No

Severity

Event

Serviceable

No

Automatically notify support

No

Related links

- IBM Support website
- Latest level of DSA
- Latest level of BMC/IMM

- **405-002-000 : BRCM:TestEEPROM Test Passed**

The test passed.

Recoverable

No

Severity

Event

Serviceable

No

Automatically notify support

No

Related links

- IBM Support website
- Latest level of DSA
- Latest level of BMC/IMM

- **405-003-000 : BRCM:TestInternalMemory Test Passed**

The test passed.

Recoverable

No

Severity

Event

Serviceable

No

Automatically notify support

No

Related links

- IBM Support website
- Latest level of DSA
- Latest level of BMC/IMM

- **405-004-000 : BRCM:TestInterrupt Test Passed**

The test passed.

Recoverable

No

Severity

Event

Serviceable

No

Automatically notify support

No

Related links

- IBM Support website
- Latest level of DSA
- Latest level of BMC/IMM

- **405-005-000 : BRCM:TestLoopbackMAC Test Passed**

The test passed.

Recoverable

No

Severity

Event

Serviceable

No

Automatically notify support

No

Related links

- IBM Support website
- Latest level of DSA
- Latest level of BMC/IMM

- **405-006-000 : BRCM:TestLoopbackPhysical Test Passed**

The test passed.

Recoverable

No

Severity

Event

Serviceable

No

Automatically notify support

No

Related links

- IBM Support website
- Latest level of DSA
- Latest level of BMC/IMM

- **405-007-000 : BRCM:TestLEDs Test Passed**

The test passed.

Recoverable

No

Severity

Event

Serviceable

No

Automatically notify support

No

Related links

- IBM Support website
- Latest level of DSA
- Latest level of BMC/IMM

- **405-800-000 : BRCM:TestControlRegisters Test Aborted**

The control registers test was canceled.

Recoverable

No

Severity

Warning

Serviceable

No

Automatically notify support

No

Related links

- IBM Support website
- Latest level of DSA
- Latest level of BMC/IMM

- **405-801-000 : BRCM:TestMIIRegisters Test Aborted**

The MII register test was canceled.

Recoverable

No

Severity

Warning

Serviceable

No

Automatically notify support

No

Related links

- IBM Support website
- Latest level of DSA
- Latest level of BMC/IMM

- **405-802-000 : BRCM:TestEEPROM Test Aborted**

The EEPROM test was canceled.

Recoverable

No

Severity

Warning

Serviceable

No

Automatically notify support

No

Related links

- IBM Support website
- Latest level of DSA
- Latest level of BMC/IMM

- **405-803-000 : BRCM:TestInternalMemory Test Aborted**

The internal memory test was canceled.

Recoverable

No

Severity

Warning

Serviceable

No

Automatically notify support

No

Related links

- IBM Support website
- Latest level of DSA
- Latest level of BMC/IMM

- **405-804-000 : BRCM:TestInterrupt Test Aborted**

The interrupt test was canceled.

Recoverable

No

Severity

Warning

Serviceable

No

Automatically notify support

No

Related links

- IBM Support website
- Latest level of DSA
- Latest level of BMC/IMM

- **405-805-000 : BRCM:TestLoopbackMAC Test Aborted**

Loopback testing at the MAC layer was canceled.

Recoverable

No

Severity

Warning

Serviceable

No

Automatically notify support

No

Related links

- IBM Support website
- Latest level of DSA
- Latest level of BMC/IMM

- **405-806-000 : BRCM:TestLoopbackPhysical Test Aborted**

Loopback testing at the physical layer was canceled.

Recoverable

No

Severity

Warning

Serviceable

No

Automatically notify support

No

Related links

- IBM Support website
- Latest level of DSA
- Latest level of BMC/IMM

- **405-807-000 : BRCM:TestLEDs Test Aborted**

Verification of status LEDs was canceled.

Recoverable

No

Severity

Warning

Serviceable

No

Automatically notify support

No

Related links

- IBM Support website
- Latest level of DSA
- Latest level of BMC/IMM

- **405-900-000 : BRCM:TestControlRegisters Test Failed**

A failure was detected while testing internal MAC registers

Recoverable

No

Severity

Error

Serviceable

Yes

Automatically notify support

No

User Response

Complete the following steps:

1. Check component firmware level and upgrade if necessary. The installed firmware level can be found in the DSA Diagnostic Event Log within the Firmware/VPD section for this component.
2. Rerun the test.
3. If failure remains, refer to "Troubleshooting by symptom" in the system "Installation and Service Guide" for the next corrective action.

Related links

- IBM Support website
- Latest level of DSA
- Latest level of BMC/IMM

- **405-901-000 : BRCM:TestMIIRegisters Test Failed**

A failure was detected while testing internal PHY registers.

Recoverable

No

Severity

Error

Serviceable

Yes

Automatically notify support

No

User Response

Complete the following steps:

1. Check component firmware level and upgrade if necessary. The installed firmware level can be found in the DSA Diagnostic Event Log within the Firmware/VPD section for this component.
2. Rerun the test.
3. If failure remains, refer to "Troubleshooting by symptom" in the system "Installation and Service Guide" for the next corrective action.

Related links

- IBM Support website
- Latest level of DSA
- Latest level of BMC/IMM

• 405-902-000 : BRCM:TestEEPROM Test Failed

A failure was detected while testing non-volatile RAM.

Recoverable

No

Severity

Error

Serviceable

Yes

Automatically notify support

No

User Response

Complete the following steps:

1. Check component firmware level and upgrade if necessary. The installed firmware level can be found in the DSA Diagnostic Event Log within the Firmware/VPD section for this component.
2. Rerun the test.
3. If failure remains, refer to "Troubleshooting by symptom" in the system "Installation and Service Guide" for the next corrective action.

Related links

- IBM Support website
- Latest level of DSA
- Latest level of BMC/IMM

• 405-903-000 : BRCM:TestInternalMemory Test Failed

A failure was detected while testing internal memory.

Recoverable

No

Severity

Error

Serviceable

Yes

Automatically notify support

No

User Response

Complete the following steps:

1. Check component firmware level and upgrade if necessary. The installed firmware level can be found in the DSA Diagnostic Event Log within the Firmware/VPD section for this component.
2. Rerun the test.
3. If failure remains, refer to "Troubleshooting by symptom" in the system "Installation and Service Guide" for the next corrective action.

Related links

- IBM Support website
- Latest level of DSA
- Latest level of BMC/IMM

• **405-904-000 : BRCM:TestInterrupt Test Failed**

A failure was detected while testing interrupts.

Recoverable

No

Severity

Error

Serviceable

Yes

Automatically notify support

No

User Response

Complete the following steps:

1. Check component firmware level and upgrade if necessary. The installed firmware level can be found in the DSA Diagnostic Event Log within the Firmware/VPD section for this component.
2. Rerun the test.
3. If failure remains, refer to "Troubleshooting by symptom" in the system "Installation and Service Guide" for the next corrective action.

Related links

- IBM Support website
- Latest level of DSA
- Latest level of BMC/IMM

• **405-905-000 : BRCM:TestLoopbackMAC Test Failed**

BRCM:TestLoopbackMAC Test Failed.

Recoverable

No

Severity

Error

Serviceable

Yes

Automatically notify support

No

User Response

Complete the following steps:

1. Check component firmware level and upgrade if necessary. The installed firmware level can be found in the DSA Diagnostic Event Log within the Firmware/VPD section for this component.
2. Rerun the test.
3. If failure remains, refer to "Troubleshooting by symptom" in the system "Installation and Service Guide" for the next corrective action.

Related links

- IBM Support website
- Latest level of DSA
- Latest level of BMC/IMM

• 405-906-000 : BRCM:TestLoopbackPhysical Test Failed

A failure was detected during the loopback test at the physical layer.

Recoverable

No

Severity

Error

Serviceable

Yes

Automatically notify support

No

User Response

Complete the following steps:

1. Check component firmware level and upgrade if necessary. The installed firmware level can be found in the DSA Diagnostic Event Log within the Firmware/VPD section for this component.
2. Rerun the test.
3. If failure remains, refer to "Troubleshooting by symptom" in the system "Installation and Service Guide" for the next corrective action.

Related links

- IBM Support website
- Latest level of DSA
- Latest level of BMC/IMM

- **405-907-000 : BRCM:TestLEDs Test Failed**

A failure was detected while verifying operation of the status LEDs.

Recoverable

No

Severity

Error

Serviceable

Yes

Automatically notify support

No

User Response

Complete the following steps:

1. Check component firmware level and upgrade if necessary. The installed firmware level can be found in the DSA Diagnostic Event Log within the Firmware/VPD section for this component.
2. Rerun the test.
3. If failure remains, refer to "Troubleshooting by symptom" in the system "Installation and Service Guide" for the next corrective action.

Related links

- IBM Support website
- Latest level of DSA
- Latest level of BMC/IMM

DSA Brocade test results

The following messages can result when you run the Brocade test.

Test results for the DSA Brocade test

The following messages can result when you run the DSA Brocade test.

- **218-000-000 : Brocade:MemoryTest Passed**

The test passed.

Recoverable

No

Severity

Event

Serviceable

No

Automatically notify support

No

Related links

- IBM Support website
- Latest level of DSA
- Latest level of BMC/IMM

- **218-001-000 : Brocade:ExternalLoopbackTest Passed**

The test passed.

Recoverable

No

Severity

Event

Serviceable

No

Automatically notify support

No

Related links

- IBM Support website
- Latest level of DSA
- Latest level of BMC/IMM

- **218-002-000 : Brocade:SerdesLoopbackTest Passed**

The test passed.

Recoverable

No

Severity

Event

Serviceable

No

Automatically notify support

No

Related links

- IBM Support website
- Latest level of DSA
- Latest level of BMC/IMM

- **218-003-000 : Brocade:PCILoopbackTest Passed**

The test passed.

Recoverable

No

Severity

Event

Serviceable

No

Automatically notify support

No

Related links

- IBM Support website
- Latest level of DSA
- Latest level of BMC/IMM

- **218-004-000 : Brocade:ExternalEthLoopbackTest Passed**

The test passed.

Recoverable

No

Severity

Event

Serviceable

No

Automatically notify support

No

Related links

- IBM Support website
- Latest level of DSA
- Latest level of BMC/IMM

- **218-005-000 : Brocade:SerdesEthLoopbackTest Passed**

The test passed.

Recoverable

No

Severity

Event

Serviceable

No

Automatically notify support

No

Related links

- IBM Support website
- Latest level of DSA
- Latest level of BMC/IMM

- **218-006-000 : Brocade:InternalLoopbackTest Passed**

The test passed.

Recoverable

No

Severity

Event

Serviceable

No

Automatically notify support

No

Related links

- IBM Support website
- Latest level of DSA
- Latest level of BMC/IMM

- **218-800-000 : Brocade:MemoryTest Aborted**

The test was canceled.

Recoverable

No

Severity

Warning

Serviceable

No

Automatically notify support

No

Related links

- IBM Support website
- Latest level of DSA
- Latest level of BMC/IMM

- **218-801-000 : Brocade:ExternalLoopbackTest Aborted**

The test was canceled.

Recoverable

No

Severity

Warning

Serviceable

No

Automatically notify support

No

Related links

- IBM Support website
- Latest level of DSA
- Latest level of BMC/IMM

- **218-802-000 : Brocade:SerdesLoopbackTest Aborted**

The test was canceled.

Recoverable

No

Severity

Warning

Serviceable

No

Automatically notify support

No

Related links

- IBM Support website
- Latest level of DSA
- Latest level of BMC/IMM

- **218-803-000 : Brocade:PCILoopbackTest Aborted**

The test was canceled.

Recoverable

No

Severity

Warning

Serviceable

No

Automatically notify support

No

Related links

- IBM Support website
- Latest level of DSA
- Latest level of BMC/IMM

- **218-804-000 : Brocade:ExternalEthLoopbackTest Aborted**

The test was canceled.

Recoverable

No

Severity

Warning

Serviceable

No

Automatically notify support

No

Related links

- IBM Support website
- Latest level of DSA
- Latest level of BMC/IMM

- **218-805-000 : Brocade:SerdesEthLoopbackTest Aborted**

The test was canceled.

Recoverable

No

Severity

Warning

Serviceable

No

Automatically notify support

No

Related links

- IBM Support website
- Latest level of DSA
- Latest level of BMC/IMM

- **218-806-000 : Brocade:InternalLoopbackTest Aborted**

The test was canceled.

Recoverable

No

Severity

Warning

Serviceable

No

Automatically notify support

No

Related links

- IBM Support website
- Latest level of DSA
- Latest level of BMC/IMM

- **218-900-000 : Brocade:MemoryTest Failed**

A failure was detected while testing the adapter memory.

Recoverable

No

Severity

Error

Serviceable

Yes

Automatically notify support

No

User Response

Complete the following steps:

1. Rerun the test.
2. Verify whether the firmware is at proper level.
3. Rerun the test.
4. If the problem remains, contact your IBM technical-support representative.

Related links

- IBM Support website
- Latest level of DSA
- Latest level of BMC/IMM

- **218-901-000 : Brocade:ExternalLoopbackTest Failed**

A failure was detected during the Loopback test.

Recoverable

No

Severity

Error

Serviceable

Yes

Automatically notify support

No

User Response

Complete the following steps:

1. Check cable connections.
2. Rerun the test.
3. Verify whether the firmware is at proper level.
4. Rerun the test.
5. If the problem remains, contact your IBM technical-support representative.

Related links

- IBM Support website
- Latest level of DSA
- Latest level of BMC/IMM

- **218-902-000 : Brocade:SerdesLoopbackTest Failed**

A failure was detected during the Loopback test.

Recoverable

No

Severity

Error

Serviceable

Yes

Automatically notify support

No

User Response

Complete the following steps:

1. Rerun the test.
2. Verify whether the firmware is at proper level.
3. Rerun the test.
4. If the problem remains, contact your IBM technical-support representative.

Related links

- IBM Support website
- Latest level of DSA
- Latest level of BMC/IMM

- **218-903-000 : Brocade:PCILoopbackTest Failed**

A failure was detected during the Loopback test.

Recoverable

No

Severity

Error

Serviceable

Yes

Automatically notify support

No

User Response

Complete the following steps:

1. Rerun the test.
2. Verify whether the firmware is at proper level.
3. Rerun the test.
4. If the problem remains, contact your IBM technical-support representative.

Related links

- IBM Support website
- Latest level of DSA
- Latest level of BMC/IMM

- **218-904-000 : Brocade:ExternalEthLoopbackTest Failed**

A failure was detected during the Loopback test.

Recoverable

No

Severity

Error

Serviceable

Yes

Automatically notify support

No

User Response

Complete the following steps:

1. Check or replace SFP/cable.
2. Rerun the test.
3. Verify whether the firmware is at proper level.
4. Rerun the test.
5. If the problem remains, contact your IBM technical-support representative.

Related links

- IBM Support website
- Latest level of DSA
- Latest level of BMC/IMM

- **218-905-000 : Brocade:SerdesEthLoopbackTest Failed**

A failure was detected during the Loopback test.

Recoverable

No

Severity

Error

Serviceable

Yes

Automatically notify support

No

User Response

Complete the following steps:

1. Rerun the test.

2. Verify whether the firmware is at proper level.
3. Rerun the test.
4. If the problem remains, contact your IBM technical-support representative.

Related links

- IBM Support website
- Latest level of DSA
- Latest level of BMC/IMM

- **218-906-000 : Brocade:InternalLoopbackTest Failed**

A failure was detected during the Loopback test.

Recoverable

No

Severity

Error

Serviceable

Yes

Automatically notify support

No

User Response

Complete the following steps:

1. Rerun the test.
2. Verify whether the firmware is at proper level.
3. Rerun the test.
4. If the problem remains, contact your IBM technical-support representative.

Related links

- IBM Support website
- Latest level of DSA
- Latest level of BMC/IMM

DSA checkpoint panel test results

The following messages can result when you run the checkpoint panel test.

Test results for the DSA checkpoint panel test

The following messages can result when you run the DSA checkpoint panel test.

- **180-000-000 : Check-point Panel Test Passed**

Check-point Panel Test Passed.

Recoverable

No

Severity

Event

Serviceable

No

Automatically notify support

No

Related links

- IBM Support website
- Latest level of DSA
- Latest level of BMC/IMM

- **180-801-000 : Check-point Panel Test Aborted**

Check-point Panel Test Aborted. BMC is unable to verify that the operator information panel cable is connected.

Recoverable

No

Severity

Warning

Serviceable

Yes

Automatically notify support

No

User Response

Complete the following steps:

1. Inspect and reseal operator information panel cable at both ends.
2. Verify that the Baseboard Management Controller (BMC) is working.
3. Run the test again.
4. If failure remains, refer to "Troubleshooting by symptom" in the system "Installation and Service Guide" for the next corrective action.

Related links

- IBM Support website
- Latest level of DSA
- Latest level of BMC/IMM

- **180-901-000 : Check-point Panel Test Failed**

Check-point Panel Test Failed. Operator reported incorrect display.

Recoverable

No

Severity

Error

Serviceable

Yes

Automatically notify support

No

User Response

Complete the following steps:

1. Check the operator information panel cabling for loose or broken connections at both ends or damage to the cable.
2. Replace the information panel cable if damage is present.
3. Run the test again.
4. Replace the operator information panel assembly.
5. Run the test again.
6. If failure remains, refer to "Troubleshooting by symptom" in the system "Installation and Service Guide" for the next corrective action.

Related links

- IBM Support website
- Latest level of DSA
- Latest level of BMC/IMM

DSA CPU stress test results

The following messages can result when you run the CPU stress test.

Test results for the DSA CPU stress test

The following messages can result when you run the DSA CPU stress test.

- **089-000-000 : CPU Stress Test Passed**

CPU Stress Test Passed.

Recoverable

No

Severity

Event

Serviceable

No

Automatically notify support

No

Related links

- IBM Support website
- Latest level of DSA

- Latest level of BMC/IMM

- **089-801-000 : CPU Stress Test Aborted**

CPU Stress Test Aborted. Internal Program Error.

Recoverable

No

Severity

Warning

Serviceable

Yes

Automatically notify support

No

User Response

Complete the following steps:

1. Turn off and restart the system.
2. Make sure that the DSA Diagnostic code is at the latest level.
3. Run the test again.
4. Check system firmware level and upgrade if necessary. The installed firmware level can be found in the DSA Diagnostic Event Log within the Firmware/VPD section for this component. The latest level firmware for this component can be found in reference to this system type at the IBM Support website.
5. Run the test again.
6. If the system has stopped responding, turn off and restart the system and then run the test again.
7. If failure remains, refer to "Troubleshooting by symptom" in the system "Installation and Service Guide" for the next corrective action.

Related links

- IBM Support website
- Latest level of DSA
- Latest level of BMC/IMM

- **089-802-000 : CPU Stress Test Aborted**

CPU Stress Test Aborted. System resource unavailability error.

Recoverable

No

Severity

Warning

Serviceable

Yes

Automatically notify support

No

User Response

Complete the following steps:

1. Turn off and restart the system.
2. Make sure that the DSA Diagnostic code is at the latest level.
3. Run the test again.
4. Check system firmware level and upgrade if necessary. The installed firmware level can be found in the DSA Diagnostic Event Log within the Firmware/VPD section for this component.
5. Run the test again.
6. If the system has stopped responding, turn off and restart the system and then run the test again.
7. If failure remains, refer to "Troubleshooting by symptom" in the system "Installation and Service Guide" for the next corrective action.

Related links

- IBM Support website
- Latest level of DSA
- Latest level of BMC/IMM

- **089-803-000 : CPU Stress Test Aborted**

CPU Stress Test Aborted. Memory size is insufficient to run the test. At least 1GB is required.

Recoverable

No

Severity

Warning

Serviceable

Yes

Automatically notify support

No

Related links

- IBM Support website
- Latest level of DSA
- Latest level of BMC/IMM

- **089-804-000 : CPU Stress Test Aborted**

CPU Stress Test Aborted. User pressed Ctrl-C.

Recoverable

No

Severity

Warning

Serviceable

Yes

Automatically notify support

No

Related links

- IBM Support website
- Latest level of DSA
- Latest level of BMC/IMM

- **089-901-000 : CPU Stress Test Failed**

CPU Stress Test Failed.

Recoverable

No

Severity

Error

Serviceable

Yes

Automatically notify support

No

User Response

Complete the following steps:

1. If the system has stopped responding, turn off and restart the system and then run the test again.
2. Make sure that the DSA Diagnostic code is at the latest level.
3. Run the test again.
4. Check system firmware level and upgrade if necessary. The installed firmware level can be found in the DSA Diagnostic Event Log within the Firmware/VPD section for this component.
5. Run the test again.
6. If the system has stopped responding, turn off and restart the system and then run the test again.
7. If failure remains, refer to "Troubleshooting by symptom" in the system "Installation and Service Guide" for the next corrective action.

Related links

- IBM Support website
- Latest level of DSA
- Latest level of BMC/IMM

DSA Emulex adapter test results

The following messages can result when you run the Emulex adapter test.

Test results for the DSA Emulex adapter test

The following messages can result when you run the DSA Emulex adapter test.

- **516-000-000 : ELXUCNA: NIC MAC LoopBackTest Passed**

The test passed.

Recoverable

No

Severity

Event

Serviceable

No

Automatically notify support

No

Related links

- IBM Support website
- Latest level of DSA
- Latest level of BMC/IMM

• **516-001-000 : ELXUCNA: NIC PHY LoopBackTest Passed**

The test passed.

Recoverable

No

Severity

Event

Serviceable

No

Automatically notify support

No

Related links

- IBM Support website
- Latest level of DSA
- Latest level of BMC/IMM

• **516-002-000 : ELXUCNA: ELXUCNA: NIC LED(Beacon)Test Passed**

The test passed.

Recoverable

No

Severity

Event

Serviceable

No

Automatically notify support

No

Related links

- IBM Support website
- Latest level of DSA
- Latest level of BMC/IMM

- **516-800-000 : ELXUCNA: NIC MAC LoopBackTest Aborted**

Loopback testing at the MAC layer was canceled.

Recoverable

No

Severity

Warning

Serviceable

No

Automatically notify support

No

Related links

- IBM Support website
- Latest level of DSA
- Latest level of BMC/IMM

- **516-801-000 : ELXUCNA: NIC PHY LoopBackTest Aborted**

Loopback testing at the physical layer was canceled.

Recoverable

No

Severity

Warning

Serviceable

No

Automatically notify support

No

Related links

- IBM Support website
- Latest level of DSA
- Latest level of BMC/IMM

- **516-802-000 : ELXUCNA: ELXUCNA: NIC LED(Beacon)Test Aborted**

Verification of status LEDs was canceled.

Recoverable

No

Severity

Warning

Serviceable

No

Automatically notify support

No

Related links

- IBM Support website
- Latest level of DSA
- Latest level of BMC/IMM

• 516-900-000 : ELXUCNA: NIC MAC LoopBackTest Failed

A failure was detected during the loopback test at the MAC layer.

Recoverable

No

Severity

Error

Serviceable

Yes

Automatically notify support

No

User Response

Complete the following steps:

1. Check component firmware level and upgrade if necessary. The installed firmware level can be found in the DSA Diagnostic Event Log within the Firmware/VPD section for this component.
2. Rerun the test.
3. If failure remains, refer to "Troubleshooting by symptom" in the system "Installation and Service Guide" for the next corrective action.

Related links

- IBM Support website
- Latest level of DSA
- Latest level of BMC/IMM

• 516-901-000 : ELXUCNA: NIC PHY LoopBackTest Failed

A failure was detected during the loopback test at the physical layer.

Recoverable

No

Severity

Error

Serviceable

Yes

Automatically notify support

No

User Response

Complete the following steps:

1. Check component firmware level and upgrade if necessary. The installed firmware level can be found in the DSA Diagnostic Event Log within the Firmware/VPD section for this component.
2. Rerun the test.
3. If failure remains, refer to "Troubleshooting by symptom" in the system "Installation and Service Guide" for the next corrective action.

Related links

- IBM Support website
- Latest level of DSA
- Latest level of BMC/IMM

- **516-902-000 : ELXUCNA: ELXUCNA: NIC LED(Beacon)Test Failed**

A failure was detected while verifying operation of the status LEDs.

Recoverable

No

Severity

Error

Serviceable

Yes

Automatically notify support

No

User Response

Complete the following steps:

1. Check component firmware level and upgrade if necessary. The installed firmware level can be found in the DSA Diagnostic Event Log within the Firmware/VPD section for this component.
2. Rerun the test.
3. If failure remains, refer to "Troubleshooting by symptom" in the system "Installation and Service Guide" for the next corrective action.

Related links

- IBM Support website
- Latest level of DSA
- Latest level of BMC/IMM

DSA EXA port ping test results

The following messages can result when you run the EXA port ping test.

Test results for the DSA EXA port ping test

The following messages can result when you run the DSA EXA port ping test.

- **401-000-000 : EXA Port Ping Test Passed**

EXA Port Ping Test Passed.

Recoverable

No

Severity

Event

Serviceable

No

Automatically notify support

No

Related links

- IBM Support website
- Latest level of DSA
- Latest level of BMC/IMM

- **401-801-000 : EXA Port Ping Test Aborted**

EXA Port Ping Test Aborted. Unable to get device base address.

Recoverable

No

Severity

Warning

Serviceable

Yes

Automatically notify support

No

User Response

Complete the following steps:

1. Remove power cables, wait for 45 seconds, reconnect and rerun the test.
2. Make sure that the scalability cable connections are as per specification.
3. Make sure that DSA and BIOS/uEFI are at the latest level.
4. If the problem remains, contact your technical-service representative.

Related links

- IBM Support website
- Latest level of DSA
- Latest level of BMC/IMM

- **401-802-000 : EXA Port Ping Test Aborted**

EXA Port Ping Test Aborted. Port connections may not be correct.

Recoverable

No

Severity

Warning

Serviceable

Yes

Automatically notify support

No

User Response

Complete the following steps:

1. Remove power cables, wait for 45 seconds, reconnect and rerun the test.
2. Make sure that the scalability cable connections are as per specification.
3. Make sure that DSA and BIOS/uEFI are at the latest level.
4. If the problem remains, contact your technical-service representative.

Related links

- IBM Support website
- Latest level of DSA
- Latest level of BMC/IMM

• **401-901-001 : EXA Port Ping Test Failed**

EXA Port Ping Test Failed.

Recoverable

No

Severity

Error

Serviceable

Yes

Automatically notify support

No

User Response

Complete the following steps:

1. Remove power cables, wait for 45 seconds, reconnect and rerun the test.
2. Make sure that the scalability cable connections are as per specification.
3. Check scalability cables for loose connections.
4. Replace the scalability cable(s) for specified port(s).
5. If the problem remains, contact your technical-service representative.

Related links

- IBM Support website
- Latest level of DSA
- Latest level of BMC/IMM

DSA hard drive test results

The following messages can result when you run the hard drive test.

Test results for the DSA hard drive test

The following messages can result when you run the DSA hard drive test.

- **217-000-000 : HDD Test Passed**

HDD Stress Test Passed.

Recoverable

No

Severity

Event

Serviceable

No

Automatically notify support

No

Related links

- IBM Support website
- Latest level of DSA
- Latest level of BMC/IMM

- **217-800-000 : HDD Test Aborted**

HDD Test Aborted. The test was canceled.

Recoverable

No

Severity

Warning

Serviceable

Yes

Automatically notify support

No

User Response

Complete the following steps:

1. Check cable connections.
2. Rerun the test.
3. Verify that Hard drive supports self test and self test logging.
4. If the problem remains, contact your technical-support representative.

Related links

- IBM Support website
- Latest level of DSA
- Latest level of BMC/IMM

- **217-900-000 : HDD Test Failed**

HDD Test Failed. The hard drive self-test detected a failure.

Recoverable

No

Severity

Error

Serviceable

Yes

Automatically notify support

No

User Response

Complete the following steps:

1. Check cable connections.
2. Rerun the test.
3. Verify the firmware is at the latest level.
4. Rerun the test.
5. If the problem remains, contact your technical-support representative.

Related links

- IBM Support website
- Latest level of DSA
- Latest level of BMC/IMM

DSA Intel network test results

The following messages can result when you run the Intel network test.

Test results for the DSA Intel network test

The following messages can result when you run the DSA Intel network test.

- **406-000-000 : IANet:Registers Test Passed**

The test passed.

Recoverable

No

Severity

Event

Serviceable

No

Automatically notify support

No

Related links

- IBM Support website
- Latest level of DSA
- Latest level of BMC/IMM

- **406-001-000 : IANet:EEPROM Test Passed**

The test passed.

Recoverable

No

Severity

Event

Serviceable

No

Automatically notify support

No

Related links

- IBM Support website
- Latest level of DSA
- Latest level of BMC/IMM

- **406-002-000 : IANet:FIFO Test Passed**

The test passed.

Recoverable

No

Severity

Event

Serviceable

No

Automatically notify support

No

Related links

- IBM Support website
- Latest level of DSA
- Latest level of BMC/IMM

- **406-003-000 : IANet:Interrupts Test Passed**

The test passed.

Recoverable

No

Severity

Event

Serviceable

No

Automatically notify support

No

Related links

- IBM Support website
- Latest level of DSA
- Latest level of BMC/IMM

• **406-004-000 : IANet:Loopback Test Passed**

The test passed.

Recoverable

No

Severity

Event

Serviceable

No

Automatically notify support

No

Related links

- IBM Support website
- Latest level of DSA
- Latest level of BMC/IMM

• **406-800-000 : IANet:Registers Test Aborted**

Registers test was canceled.

Recoverable

No

Severity

Warning

Serviceable

No

Automatically notify support

No

Related links

- IBM Support website
- Latest level of DSA
- Latest level of BMC/IMM

- **406-801-000 : IANet:EEPROM Test Aborted**

EEPROM test was canceled.

Recoverable

No

Severity

Warning

Serviceable

No

Automatically notify support

No

Related links

- IBM Support website
- Latest level of DSA
- Latest level of BMC/IMM

- **406-802-000 : IANet:FIFO Test Aborted**

FIFO test was canceled.

Recoverable

No

Severity

Warning

Serviceable

No

Automatically notify support

No

Related links

- IBM Support website
- Latest level of DSA
- Latest level of BMC/IMM

- **406-803-000 : IANet:Interrupts Test Aborted**

Interrupt test was canceled.

Recoverable

No

Severity

Warning

Serviceable

No

Automatically notify support

No

Related links

- IBM Support website
- Latest level of DSA
- Latest level of BMC/IMM

- **406-804-000 : IANet:Loopback Test Aborted**

Loopback test was canceled.

Recoverable

No

Severity

Warning

Serviceable

No

Automatically notify support

No

Related links

- IBM Support website
- Latest level of DSA
- Latest level of BMC/IMM

- **406-900-000 : IANet:Registers Test Failed**

A failure was detected during the Registers test.

Recoverable

No

Severity

Error

Serviceable

Yes

Automatically notify support

No

User Response

Complete the following steps:

1. Check component firmware level and upgrade if necessary. The installed firmware level can be found in the DSA Diagnostic Event Log within the Firmware/VPD section for this component.
2. Rerun the test.
3. If failure remains, refer to "Troubleshooting by symptom" in the system "Installation and Service Guide" for the next corrective action.

Related links

- IBM Support website
- Latest level of DSA
- Latest level of BMC/IMM

- **406-901-000 : IANet:EEPROM Test Failed**

A failure was detected during the EEPROM test.

Recoverable

No

Severity

Error

Serviceable

Yes

Automatically notify support

No

User Response

Complete the following steps:

1. Check component firmware level and upgrade if necessary. The installed firmware level can be found in the DSA Diagnostic Event Log within the Firmware/VPD section for this component.
2. Rerun the test.
3. If failure remains, refer to "Troubleshooting by symptom" in the system "Installation and Service Guide" for the next corrective action.

Related links

- IBM Support website
- Latest level of DSA
- Latest level of BMC/IMM

- **406-902-000 : IANet:FIFO Test Failed**

A failure was detected during the FIFO test.

Recoverable

No

Severity

Error

Serviceable

Yes

Automatically notify support

No

User Response

Complete the following steps:

1. Check component firmware level and upgrade if necessary. The installed firmware level can be found in the DSA Diagnostic Event Log within the Firmware/VPD section for this component.

2. Rerun the test.
3. If failure remains, refer to "Troubleshooting by symptom" in the system "Installation and Service Guide" for the next corrective action.

Related links

- IBM Support website
- Latest level of DSA
- Latest level of BMC/IMM

- **406-903-000 : IANet:Interrupts Test Failed**

A failure was detected during the Interrupt test.

Recoverable

No

Severity

Error

Serviceable

Yes

Automatically notify support

No

User Response

Complete the following steps:

1. Check component firmware level and upgrade if necessary. The installed firmware level can be found in the DSA Diagnostic Event Log within the Firmware/VPD section for this component.
2. Rerun the test.
3. Check interrupt assignments in the PCI Hardware section of the DSA Diagnostic Log. If the ethernet device is sharing interrupts, if possible modify the interrupt assignments using F1 Setup to assign a unique interrupt to the device.
4. Rerun the test.
5. If failure remains, refer to "Troubleshooting by symptom" in the system "Installation and Service Guide" for the next corrective action.

Related links

- IBM Support website
- Latest level of DSA
- Latest level of BMC/IMM

- **406-904-000 : IANet:Loopback Test Failed**

A failure was detected during the Loopback test.

Recoverable

No

Severity

Error

Serviceable

Yes

Automatically notify support

No

User Response

Complete the following steps:

1. Check the Ethernet cable for damage and ensure correct cable type and attachment.
2. Check component firmware level and upgrade if necessary. The installed firmware level can be found in the DSA Diagnostic Event Log within the Firmware/VPD section for this component.
3. Rerun the test.
4. If failure remains, refer to "Troubleshooting by symptom" in the system "Installation and Service Guide" for the next corrective action.

Related links

- IBM Support website
- Latest level of DSA
- Latest level of BMC/IMM

DSA LSI hard drive test results

The following messages can result when you run the LSI hard drive test.

Test results for the DSA LSI hard drive test

The following messages can result when you run the DSA LSI hard drive test.

- **407-000-000 : LSIESG:DiskDefaultDiagnostic Test Passed**

The test passed.

Recoverable

No

Severity

Event

Serviceable

No

Automatically notify support

No

Related links

- IBM Support website
- Latest level of DSA
- Latest level of BMC/IMM

- **407-800-000 : LSIESG:DiskDefaultDiagnostic Test Aborted**

The test was canceled.

Recoverable

No

Severity

Warning

Serviceable

No

Automatically notify support

No

Related links

- IBM Support website
- Latest level of DSA
- Latest level of BMC/IMM

• **407-900-000 : LSIESG:DiskDefaultDiagnostic Test Failed**

The hard drive self-test detected a failure.

Recoverable

No

Severity

Error

Serviceable

Yes

Automatically notify support

No

User Response

Complete the following steps:

1. Check cable connections.
2. Rerun the test.
3. Verify whether the firmware is at the latest level.
4. Rerun the test.
5. If the problem remains, contact your IBM technical-support representative.

Related links

- IBM Support website
- Latest level of DSA
- Latest level of BMC/IMM

DSA Mellanox adapter test results

The following messages can result when you run the Mellanox adapter test.

Test results for the DSA Mellanox adapter test

The following messages can result when you run the DSA Mellanox adapter test.

- **408-000-000 : MLNX:MLNX_DiagnosticTestEthernetPort Test Passed**

Port Test Passed.

Recoverable

No

Severity

Event

Serviceable

No

Automatically notify support

No

Related links

- IBM Support website
- Latest level of DSA
- Latest level of BMC/IMM

- **408-001-000 : MLNX:MLNX_DiagnosticTestIBPort Test Passed**

Port Test Passed.

Recoverable

No

Severity

Event

Serviceable

No

Automatically notify support

No

Related links

- IBM Support website
- Latest level of DSA
- Latest level of BMC/IMM

- **408-800-000 : MLNX:MLNX_DiagnosticTestEthernetPort Test Aborted**

Port Test was canceled.

Recoverable

No

Severity

Warning

Serviceable

No

Automatically notify support

No

Related links

- IBM Support website
- Latest level of DSA
- Latest level of BMC/IMM

• **408-801-000 : MLNX:MLNX_DiagnosticTestIBPort Test Aborted**

Port Test was canceled.

Recoverable

No

Severity

Warning

Serviceable

No

Automatically notify support

No

Related links

- IBM Support website
- Latest level of DSA
- Latest level of BMC/IMM

• **408-900-000 : MLNX:MLNX_DiagnosticTestEthernetPort Test Failed**

Port Test Failed.

Recoverable

No

Severity

Error

Serviceable

Yes

Automatically notify support

No

User Response

Complete the following steps:

1. Make sure that the physical link of the port under test is in the active state.
2. If these conditions were met but the test keeps failing the port's adapter might be faulty.
3. Try replacing the adapter and repeating the test.

Related links

- IBM Support website

- Latest level of DSA
- Latest level of BMC/IMM

- **408-901-000 : MLNX:MLNX_DiagnosticTestIBPort Test Failed**

Port Test Failed.

Recoverable

No

Severity

Error

Serviceable

Yes

Automatically notify support

No

User Response

Complete the following steps:

1. Make sure that the physical link of the port under test is in the active state and a subnet manager is running on the fabric to which the port is attached.
2. If these conditions were met but the test keeps failing, the port's adapter might be faulty.
3. Try replacing the adapter and repeating the test.

Related links

- IBM Support website
- Latest level of DSA
- Latest level of BMC/IMM

DSA memory isolation test results

The following messages can result when you run the memory isolation test.

Test results for the DSA memory isolation test

The following messages can result when you run the DSA memory isolation test.

- **201-000-000 : Standalone Memory Test Passed**

Quick/Full Memory Test All CPUs Passed.

Recoverable

No

Severity

Event

Serviceable

No

Automatically notify support

No

Related links

- IBM Support website
- Latest level of DSA
- Latest level of BMC/IMM

• **201-000-001 : Standalone Memory Test Passed**

Quick/Full Memory Test CPU 1 Passed.

Recoverable

No

Severity

Event

Serviceable

No

Automatically notify support

No

Related links

- IBM Support website
- Latest level of DSA
- Latest level of BMC/IMM

• **201-000-002 : Standalone Memory Test Passed**

Quick/Full Memory Test CPU 2 Passed.

Recoverable

No

Severity

Event

Serviceable

No

Automatically notify support

No

Related links

- IBM Support website
- Latest level of DSA
- Latest level of BMC/IMM

• **201-000-003 : Standalone Memory Test Passed**

Quick/Full Memory Test CPU 3 Passed.

Recoverable

No

Severity

Event

Serviceable

No

Automatically notify support

No

Related links

- IBM Support website
- Latest level of DSA
- Latest level of BMC/IMM

- **201-000-004 : Standalone Memory Test Passed**

Quick/Full Memory Test CPU 4 Passed.

Recoverable

No

Severity

Event

Serviceable

No

Automatically notify support

No

Related links

- IBM Support website
- Latest level of DSA
- Latest level of BMC/IMM

- **201-811-000 : Standalone Memory Test Aborted**

Unable to Locate SMBIOS key "_SM_".

Recoverable

No

Severity

Warning

Serviceable

No

Automatically notify support

No

User Response

Complete the following steps:

1. Perform the actions mentioned one at a time and try the test after each action.

2. If the problem remains, contact your technical-service representative.
3. Turn off the system and disconnect it from power. Wait for 45 seconds. Reseat DIMM(s). Reconnect it to power.
4. Make sure that DSA and BIOS/uEFI are at the latest level.

Related links

- IBM Support website
- Latest level of DSA
- Latest level of BMC/IMM

- **201-811-001 : Standalone Memory Test Aborted**

Unable to Locate SMBIOS key "_SM_".

Recoverable

No

Severity

Warning

Serviceable

No

Automatically notify support

No

User Response

Complete the following steps:

1. Perform the actions mentioned one at a time and try the test after each action.
2. If the problem remains, contact your technical-service representative.
3. Turn off the system and disconnect it from power. Wait for 45 seconds. Reseat DIMM(s). Reconnect it to power.
4. Make sure that DSA and BIOS/uEFI are at the latest level.

Related links

- IBM Support website
- Latest level of DSA
- Latest level of BMC/IMM

- **201-811-002 : Standalone Memory Test Aborted**

Unable to Locate SMBIOS key "_SM_".

Recoverable

No

Severity

Warning

Serviceable

No

Automatically notify support

No

User Response

Complete the following steps:

1. Perform the actions mentioned one at a time and try the test after each action.
2. If the problem remains, contact your technical-service representative.
3. Turn off the system and disconnect it from power. Wait for 45 seconds. Reseat DIMM(s). Reconnect it to power.
4. Make sure that DSA and BIOS/uEFI are at the latest level.

Related links

- IBM Support website
- Latest level of DSA
- Latest level of BMC/IMM

• **201-811-003 : Standalone Memory Test Aborted**

Unable to Locate SMBIOS key "_SM_".

Recoverable

No

Severity

Warning

Serviceable

No

Automatically notify support

No

User Response

Complete the following steps:

1. Perform the actions mentioned one at a time and try the test after each action.
2. If the problem remains, contact your technical-service representative.
3. Turn off the system and disconnect it from power. Wait for 45 seconds. Reseat DIMM(s). Reconnect it to power.
4. Make sure that DSA and BIOS/uEFI are at the latest level.

Related links

- IBM Support website
- Latest level of DSA
- Latest level of BMC/IMM

• **201-812-000 : Standalone Memory Test Aborted**

Memory test is not supported for this system.

Recoverable

No

Severity

Warning

Serviceable

No

Automatically notify support

No

User Response

Complete the following steps:

1. Perform the actions mentioned one at a time and try the test after each action.
2. If the problem remains, contact your technical-service representative.
3. Turn off the system and disconnect it from power. Wait for 45 seconds. Reseat DIMM(s). Reconnect it to power.
4. Make sure that DSA and BIOS/uEFI are at the latest level.

Related links

- IBM Support website
- Latest level of DSA
- Latest level of BMC/IMM

• **201-812-001 : Standalone Memory Test Aborted**

Memory test is not supported for this system.

Recoverable

No

Severity

Warning

Serviceable

No

Automatically notify support

No

User Response

Complete the following steps:

1. Perform the actions mentioned one at a time and try the test after each action.
2. If the problem remains, contact your technical-service representative.
3. Turn off the system and disconnect it from power. Wait for 45 seconds. Reseat DIMM(s). Reconnect it to power.
4. Make sure that DSA and BIOS/uEFI are at the latest level.

Related links

- IBM Support website
- Latest level of DSA
- Latest level of BMC/IMM

• **201-812-002 : Standalone Memory Test Aborted**

Memory test is not supported for this system.

Recoverable

No

Severity

Warning

Serviceable

No

Automatically notify support

No

User Response

Complete the following steps:

1. Perform the actions mentioned one at a time and try the test after each action.
2. If the problem remains, contact your technical-service representative.
3. Turn off the system and disconnect it from power. Wait for 45 seconds. Reseat DIMM(s). Reconnect it to power.
4. Make sure that DSA and BIOS/uEFI are at the latest level.

Related links

- IBM Support website
- Latest level of DSA
- Latest level of BMC/IMM

• 201-812-003 : Standalone Memory Test Aborted

Memory test is not supported for this system.

Recoverable

No

Severity

Warning

Serviceable

No

Automatically notify support

No

User Response

Complete the following steps:

1. Perform the actions mentioned one at a time and try the test after each action.
2. If the problem remains, contact your technical-service representative.
3. Turn off the system and disconnect it from power. Wait for 45 seconds. Reseat DIMM(s). Reconnect it to power.
4. Make sure that DSA and BIOS/uEFI are at the latest level.

Related links

- IBM Support website
- Latest level of DSA
- Latest level of BMC/IMM

- **201-813-000 : Standalone Memory Test Aborted**

Chipset Error: Can not turn OFF ECC error reporting in CPU.

Recoverable

No

Severity

Warning

Serviceable

No

Automatically notify support

No

User Response

Complete the following steps:

1. Perform the actions mentioned one at a time and try the test after each action.
2. If the problem remains, contact your technical-service representative.
3. Turn off the system and disconnect it from power. Wait for 45 seconds. Reseat DIMM(s). Reconnect it to power.
4. Make sure that DSA and BIOS/uEFI are at the latest level.

Related links

- IBM Support website
- Latest level of DSA
- Latest level of BMC/IMM

- **201-813-001 : Standalone Memory Test Aborted**

Chipset Error: Can not turn OFF ECC error reporting in CPU.

Recoverable

No

Severity

Warning

Serviceable

No

Automatically notify support

No

User Response

Complete the following steps:

1. Perform the actions mentioned one at a time and try the test after each action.
2. If the problem remains, contact your technical-service representative.
3. Turn off the system and disconnect it from power. Wait for 45 seconds. Reseat DIMM(s). Reconnect it to power.
4. Make sure that DSA and BIOS/uEFI are at the latest level.

Related links

- IBM Support website
- Latest level of DSA
- Latest level of BMC/IMM

- **201-813-002 : Standalone Memory Test Aborted**

Chipset Error: Can not turn OFF ECC error reporting in CPU.

Recoverable

No

Severity

Warning

Serviceable

No

Automatically notify support

No

User Response

Complete the following steps:

1. Perform the actions mentioned one at a time and try the test after each action.
2. If the problem remains, contact your technical-service representative.
3. Turn off the system and disconnect it from power. Wait for 45 seconds. Reseat DIMM(s). Reconnect it to power.
4. Make sure that DSA and BIOS/uEFI are at the latest level.

Related links

- IBM Support website
- Latest level of DSA
- Latest level of BMC/IMM

- **201-813-003 : Standalone Memory Test Aborted**

Chipset Error: Can not turn OFF ECC error reporting in CPU.

Recoverable

No

Severity

Warning

Serviceable

No

Automatically notify support

No

User Response

Complete the following steps:

1. Perform the actions mentioned one at a time and try the test after each action.
2. If the problem remains, contact your technical-service representative.

3. Turn off the system and disconnect it from power. Wait for 45 seconds. Reseat DIMM(s). Reconnect it to power.
4. Make sure that DSA and BIOS/uEFI are at the latest level.

Related links

- IBM Support website
- Latest level of DSA
- Latest level of BMC/IMM

- **201-814-000 : Standalone Memory Test Aborted**

Chipset Error: Can not disable Scubbing feature for CPU.

Recoverable

No

Severity

Warning

Serviceable

No

Automatically notify support

No

User Response

Complete the following steps:

1. Perform the actions mentioned one at a time and try the test after each action.
2. If the problem remains, contact your technical-service representative.
3. Turn off the system and disconnect it from power. Wait for 45 seconds. Reseat DIMM(s). Reconnect it to power.
4. Make sure that DSA and BIOS/uEFI are at the latest level.

Related links

- IBM Support website
- Latest level of DSA
- Latest level of BMC/IMM

- **201-814-001 : Standalone Memory Test Aborted**

Chipset Error: Can not disable Scubbing feature for CPU.

Recoverable

No

Severity

Warning

Serviceable

No

Automatically notify support

No

User Response

Complete the following steps:

1. Perform the actions mentioned one at a time and try the test after each action.
2. If the problem remains, contact your technical-service representative.
3. Turn off the system and disconnect it from power. Wait for 45 seconds. Reseat DIMM(s). Reconnect it to power.
4. Make sure that DSA and BIOS/uEFI are at the latest level.

Related links

- IBM Support website
- Latest level of DSA
- Latest level of BMC/IMM

• 201-814-002 : Standalone Memory Test Aborted

Chipset Error: Can not disable Scubbing feature for CPU.

Recoverable

No

Severity

Warning

Serviceable

No

Automatically notify support

No

User Response

Complete the following steps:

1. Perform the actions mentioned one at a time and try the test after each action.
2. If the problem remains, contact your technical-service representative.
3. Turn off the system and disconnect it from power. Wait for 45 seconds. Reseat DIMM(s). Reconnect it to power.
4. Make sure that DSA and BIOS/uEFI are at the latest level.

Related links

- IBM Support website
- Latest level of DSA
- Latest level of BMC/IMM

• 201-814-003 : Standalone Memory Test Aborted

Chipset Error: Can not disable Scubbing feature for CPU.

Recoverable

No

Severity

Warning

Serviceable

No

Automatically notify support

No

User Response

Complete the following steps:

1. Perform the actions mentioned one at a time and try the test after each action.
2. If the problem remains, contact your technical-service representative.
3. Turn off the system and disconnect it from power. Wait for 45 seconds. Reseat DIMM(s). Reconnect it to power.
4. Make sure that DSA and BIOS/uEFI are at the latest level.

Related links

- IBM Support website
- Latest level of DSA
- Latest level of BMC/IMM

- **201-815-000 : Standalone Memory Test Aborted**

Program Error with Quick Memory Menu Option Selection.

Recoverable

No

Severity

Warning

Serviceable

No

Automatically notify support

No

User Response

Complete the following steps:

1. Perform the actions mentioned one at a time and try the test after each action.
2. If the problem remains, contact your technical-service representative.
3. Turn off the system and disconnect it from power. Wait for 45 seconds. Reseat DIMM(s). Reconnect it to power.
4. Make sure that DSA and BIOS/uEFI are at the latest level.

Related links

- IBM Support website
- Latest level of DSA
- Latest level of BMC/IMM

- **201-815-001 : Standalone Memory Test Aborted**

Program Error with Quick Memory Menu Option Selection.

Recoverable

No

Severity

Warning

Serviceable

No

Automatically notify support

No

User Response

Complete the following steps:

1. Perform the actions mentioned one at a time and try the test after each action.
2. If the problem remains, contact your technical-service representative.
3. Turn off the system and disconnect it from power. Wait for 45 seconds. Reseat DIMM(s). Reconnect it to power.
4. Make sure that DSA and BIOS/uEFI are at the latest level.

Related links

- IBM Support website
- Latest level of DSA
- Latest level of BMC/IMM

• 201-815-002 : Standalone Memory Test Aborted

Program Error with Quick Memory Menu Option Selection.

Recoverable

No

Severity

Warning

Serviceable

No

Automatically notify support

No

User Response

Complete the following steps:

1. Perform the actions mentioned one at a time and try the test after each action.
2. If the problem remains, contact your technical-service representative.
3. Turn off the system and disconnect it from power. Wait for 45 seconds. Reseat DIMM(s). Reconnect it to power.
4. Make sure that DSA and BIOS/uEFI are at the latest level.

Related links

- IBM Support website
- Latest level of DSA
- Latest level of BMC/IMM

- **201-815-003 : Standalone Memory Test Aborted**

Program Error with Quick Memory Menu Option Selection.

Recoverable

No

Severity

Warning

Serviceable

No

Automatically notify support

No

User Response

Complete the following steps:

1. Perform the actions mentioned one at a time and try the test after each action.
2. If the problem remains, contact your technical-service representative.
3. Turn off the system and disconnect it from power. Wait for 45 seconds. Reseat DIMM(s). Reconnect it to power.
4. Make sure that DSA and BIOS/uEFI are at the latest level.

Related links

- IBM Support website
- Latest level of DSA
- Latest level of BMC/IMM

- **201-816-000 : Standalone Memory Test Aborted**

Program Error with Full Memory Menu Option Selection.

Recoverable

No

Severity

Warning

Serviceable

No

Automatically notify support

No

User Response

Complete the following steps:

1. Perform the actions mentioned one at a time and try the test after each action.
2. If the problem remains, contact your technical-service representative.
3. Turn off the system and disconnect it from power. Wait for 45 seconds. Reseat DIMM(s). Reconnect it to power.
4. Make sure that DSA and BIOS/uEFI are at the latest level.

Related links

- IBM Support website
- Latest level of DSA
- Latest level of BMC/IMM

- **201-816-001 : Standalone Memory Test Aborted**

Program Error with Full Memory Menu Option Selection.

Recoverable

No

Severity

Warning

Serviceable

No

Automatically notify support

No

User Response

Complete the following steps:

1. Perform the actions mentioned one at a time and try the test after each action.
2. If the problem remains, contact your technical-service representative.
3. Turn off the system and disconnect it from power. Wait for 45 seconds. Reseat DIMM(s). Reconnect it to power.
4. Make sure that DSA and BIOS/uEFI are at the latest level.

Related links

- IBM Support website
- Latest level of DSA
- Latest level of BMC/IMM

- **201-816-002 : Standalone Memory Test Aborted**

Program Error with Full Memory Menu Option Selection.

Recoverable

No

Severity

Warning

Serviceable

No

Automatically notify support

No

User Response

Complete the following steps:

1. Perform the actions mentioned one at a time and try the test after each action.
2. If the problem remains, contact your technical-service representative.

3. Turn off the system and disconnect it from power. Wait for 45 seconds. Reseat DIMM(s). Reconnect it to power.
4. Make sure that DSA and BIOS/uEFI are at the latest level.

Related links

- IBM Support website
- Latest level of DSA
- Latest level of BMC/IMM

- **201-816-003 : Standalone Memory Test Aborted**

Program Error with Full Memory Menu Option Selection.

Recoverable

No

Severity

Warning

Serviceable

No

Automatically notify support

No

User Response

Complete the following steps:

1. Perform the actions mentioned one at a time and try the test after each action.
2. If the problem remains, contact your technical-service representative.
3. Turn off the system and disconnect it from power. Wait for 45 seconds. Reseat DIMM(s). Reconnect it to power.
4. Make sure that DSA and BIOS/uEFI are at the latest level.

Related links

- IBM Support website
- Latest level of DSA
- Latest level of BMC/IMM

- **201-818-000 : Standalone Memory Test Aborted**

Unable to Locate SMBIOS key "_SM_".

Recoverable

No

Severity

Warning

Serviceable

No

Automatically notify support

No

User Response

Complete the following steps:

1. Perform the actions mentioned one at a time and try the test after each action.
2. If the problem remains, contact your technical-service representative.
3. Turn off the system and disconnect it from power. Wait for 45 seconds. Reseat DIMM(s). Reconnect it to power.
4. Make sure that DSA and BIOS/uEFI are at the latest level.

Related links

- IBM Support website
- Latest level of DSA
- Latest level of BMC/IMM

• 201-818-001 : Standalone Memory Test Aborted

Unable to Locate SMBIOS key "_SM_".

Recoverable

No

Severity

Warning

Serviceable

No

Automatically notify support

No

User Response

Complete the following steps:

1. Perform the actions mentioned one at a time and try the test after each action.
2. If the problem remains, contact your technical-service representative.
3. Turn off the system and disconnect it from power. Wait for 45 seconds. Reseat DIMM(s). Reconnect it to power.
4. Make sure that DSA and BIOS/uEFI are at the latest level.

Related links

- IBM Support website
- Latest level of DSA
- Latest level of BMC/IMM

• 201-818-002 : Standalone Memory Test Aborted

Unable to Locate SMBIOS key "_SM_".

Recoverable

No

Severity

Warning

Serviceable

No

Automatically notify support

No

User Response

Complete the following steps:

1. Perform the actions mentioned one at a time and try the test after each action.
2. If the problem remains, contact your technical-service representative.
3. Turn off the system and disconnect it from power. Wait for 45 seconds. Reseat DIMM(s). Reconnect it to power.
4. Make sure that DSA and BIOS/uEFI are at the latest level.

Related links

- IBM Support website
- Latest level of DSA
- Latest level of BMC/IMM

• 201-818-003 : Standalone Memory Test Aborted

Unable to Locate SMBIOS key "_SM_".

Recoverable

No

Severity

Warning

Serviceable

No

Automatically notify support

No

User Response

Complete the following steps:

1. Perform the actions mentioned one at a time and try the test after each action.
2. If the problem remains, contact your technical-service representative.
3. Turn off the system and disconnect it from power. Wait for 45 seconds. Reseat DIMM(s). Reconnect it to power.
4. Make sure that DSA and BIOS/uEFI are at the latest level.

Related links

- IBM Support website
- Latest level of DSA
- Latest level of BMC/IMM

• 201-819-000 : Standalone Memory Test Aborted

The start-end address ranges in the restricted area of the memory.

Recoverable

No

Severity

Warning

Serviceable

No

Automatically notify support

No

User Response

Complete the following steps:

1. Perform the actions mentioned one at a time and try the test after each action.
2. If the problem remains, contact your technical-service representative.
3. Turn off the system and disconnect it from power. Wait for 45 seconds. Reseat DIMM(s). Reconnect it to power.
4. Make sure that DSA and BIOS/uEFI are at the latest level.

Related links

- IBM Support website
- Latest level of DSA
- Latest level of BMC/IMM

• 201-819-001 : Standalone Memory Test Aborted

The start-end address ranges in the restricted area of the memory.

Recoverable

No

Severity

Warning

Serviceable

No

Automatically notify support

No

User Response

Complete the following steps:

1. Perform the actions mentioned one at a time and try the test after each action.
2. If the problem remains, contact your technical-service representative.
3. Turn off the system and disconnect it from power. Wait for 45 seconds. Reseat DIMM(s). Reconnect it to power.
4. Make sure that DSA and BIOS/uEFI are at the latest level.

Related links

- IBM Support website
- Latest level of DSA
- Latest level of BMC/IMM

- **201-819-002 : Standalone Memory Test Aborted**

The start-end address ranges in the restricted area of the memory.

Recoverable

No

Severity

Warning

Serviceable

No

Automatically notify support

No

User Response

Complete the following steps:

1. Perform the actions mentioned one at a time and try the test after each action.
2. If the problem remains, contact your technical-service representative.
3. Turn off the system and disconnect it from power. Wait for 45 seconds. Reseat DIMM(s). Reconnect it to power.
4. Make sure that DSA and BIOS/uEFI are at the latest level.

Related links

- IBM Support website
- Latest level of DSA
- Latest level of BMC/IMM

- **201-819-003 : Standalone Memory Test Aborted**

The start-end address ranges in the restricted area of the memory.

Recoverable

No

Severity

Warning

Serviceable

No

Automatically notify support

No

User Response

Complete the following steps:

1. Perform the actions mentioned one at a time and try the test after each action.
2. If the problem remains, contact your technical-service representative.
3. Turn off the system and disconnect it from power. Wait for 45 seconds. Reseat DIMM(s). Reconnect it to power.
4. Make sure that DSA and BIOS/uEFI are at the latest level.

Related links

- IBM Support website
- Latest level of DSA
- Latest level of BMC/IMM

- **201-820-000 : Standalone Memory Test Aborted**

Memory Upper limit is less than 16 Mbytes.

Recoverable

No

Severity

Warning

Serviceable

No

Automatically notify support

No

User Response

Complete the following steps:

1. Perform the actions mentioned one at a time and try the test after each action.
2. If the problem remains, contact your technical-service representative.
3. Turn off the system and disconnect it from power. Wait for 45 seconds. Reseat DIMM(s). Reconnect it to power.
4. Make sure that DSA and BIOS/uEFI are at the latest level.

Related links

- IBM Support website
- Latest level of DSA
- Latest level of BMC/IMM

- **201-820-001 : Standalone Memory Test Aborted**

Memory Upper limit is less than 16 Mbytes.

Recoverable

No

Severity

Warning

Serviceable

No

Automatically notify support

No

User Response

Complete the following steps:

1. Perform the actions mentioned one at a time and try the test after each action.
2. If the problem remains, contact your technical-service representative.

3. Turn off the system and disconnect it from power. Wait for 45 seconds. Reseat DIMM(s). Reconnect it to power.
4. Make sure that DSA and BIOS/uEFI are at the latest level.

Related links

- IBM Support website
- Latest level of DSA
- Latest level of BMC/IMM

- **201-820-002 : Standalone Memory Test Aborted**

Memory Upper limit is less than 16 Mbytes.

Recoverable

No

Severity

Warning

Serviceable

No

Automatically notify support

No

User Response

Complete the following steps:

1. Perform the actions mentioned one at a time and try the test after each action.
2. If the problem remains, contact your technical-service representative.
3. Turn off the system and disconnect it from power. Wait for 45 seconds. Reseat DIMM(s). Reconnect it to power.
4. Make sure that DSA and BIOS/uEFI are at the latest level.

Related links

- IBM Support website
- Latest level of DSA
- Latest level of BMC/IMM

- **201-820-003 : Standalone Memory Test Aborted**

Memory Upper limit is less than 16 Mbytes.

Recoverable

No

Severity

Warning

Serviceable

No

Automatically notify support

No

User Response

Complete the following steps:

1. Perform the actions mentioned one at a time and try the test after each action.
2. If the problem remains, contact your technical-service representative.
3. Turn off the system and disconnect it from power. Wait for 45 seconds. Reseat DIMM(s). Reconnect it to power.
4. Make sure that DSA and BIOS/uEFI are at the latest level.

Related links

- IBM Support website
- Latest level of DSA
- Latest level of BMC/IMM

• 201-821-000 : Standalone Memory Test Aborted

Variable range MTRR registers are larger than fixed range MTRR registers.

Recoverable

No

Severity

Warning

Serviceable

No

Automatically notify support

No

User Response

Complete the following steps:

1. Perform the actions mentioned one at a time and try the test after each action.
2. If the problem remains, contact your technical-service representative.
3. Turn off the system and disconnect it from power. Wait for 45 seconds. Reseat DIMM(s). Reconnect it to power.
4. Make sure that DSA and BIOS/uEFI are at the latest level.

Related links

- IBM Support website
- Latest level of DSA
- Latest level of BMC/IMM

• 201-821-001 : Standalone Memory Test Aborted

Variable range MTRR registers are larger than fixed range MTRR registers.

Recoverable

No

Severity

Warning

Serviceable

No

Automatically notify support

No

User Response

Complete the following steps:

1. Perform the actions mentioned one at a time and try the test after each action.
2. If the problem remains, contact your technical-service representative.
3. Turn off the system and disconnect it from power. Wait for 45 seconds. Reseat DIMM(s). Reconnect it to power.
4. Make sure that DSA and BIOS/uEFI are at the latest level.

Related links

- IBM Support website
- Latest level of DSA
- Latest level of BMC/IMM

• 201-821-002 : Standalone Memory Test Aborted

Variable range MTRR registers are larger than fixed range MTRR registers.

Recoverable

No

Severity

Warning

Serviceable

No

Automatically notify support

No

User Response

Complete the following steps:

1. Perform the actions mentioned one at a time and try the test after each action.
2. If the problem remains, contact your technical-service representative.
3. Turn off the system and disconnect it from power. Wait for 45 seconds. Reseat DIMM(s). Reconnect it to power.
4. Make sure that DSA and BIOS/uEFI are at the latest level.

Related links

- IBM Support website
- Latest level of DSA
- Latest level of BMC/IMM

• 201-821-003 : Standalone Memory Test Aborted

Variable range MTRR registers are larger than fixed range MTRR registers.

Recoverable

No

Severity

Warning

Serviceable

No

Automatically notify support

No

User Response

Complete the following steps:

1. Perform the actions mentioned one at a time and try the test after each action.
2. If the problem remains, contact your technical-service representative.
3. Turn off the system and disconnect it from power. Wait for 45 seconds. Reseat DIMM(s). Reconnect it to power.
4. Make sure that DSA and BIOS/uEFI are at the latest level.

Related links

- IBM Support website
- Latest level of DSA
- Latest level of BMC/IMM

• 201-822-000 : Standalone Memory Test Aborted

Invalid MTRR service request.

Recoverable

No

Severity

Warning

Serviceable

No

Automatically notify support

No

User Response

Complete the following steps:

1. Perform the actions mentioned one at a time and try the test after each action.
2. If the problem remains, contact your technical-service representative.
3. Turn off the system and disconnect it from power. Wait for 45 seconds. Reseat DIMM(s). Reconnect it to power.
4. Make sure that DSA and BIOS/uEFI are at the latest level.

Related links

- IBM Support website
- Latest level of DSA
- Latest level of BMC/IMM

- **201-822-001 : Standalone Memory Test Aborted**

Invalid MTRR service request.

Recoverable

No

Severity

Warning

Serviceable

No

Automatically notify support

No

User Response

Complete the following steps:

1. Perform the actions mentioned one at a time and try the test after each action.
2. If the problem remains, contact your technical-service representative.
3. Turn off the system and disconnect it from power. Wait for 45 seconds. Reseat DIMM(s). Reconnect it to power.
4. Make sure that DSA and BIOS/uEFI are at the latest level.

Related links

- IBM Support website
- Latest level of DSA
- Latest level of BMC/IMM

- **201-822-002 : Standalone Memory Test Aborted**

Invalid MTRR service request.

Recoverable

No

Severity

Warning

Serviceable

No

Automatically notify support

No

User Response

Complete the following steps:

1. Perform the actions mentioned one at a time and try the test after each action.
2. If the problem remains, contact your technical-service representative.
3. Turn off the system and disconnect it from power. Wait for 45 seconds. Reseat DIMM(s). Reconnect it to power.
4. Make sure that DSA and BIOS/uEFI are at the latest level.

Related links

- IBM Support website
- Latest level of DSA
- Latest level of BMC/IMM

- **201-822-003 : Standalone Memory Test Aborted**

Invalid MTRR service request.

Recoverable

No

Severity

Warning

Serviceable

No

Automatically notify support

No

User Response

Complete the following steps:

1. Perform the actions mentioned one at a time and try the test after each action.
2. If the problem remains, contact your technical-service representative.
3. Turn off the system and disconnect it from power. Wait for 45 seconds. Reseat DIMM(s). Reconnect it to power.
4. Make sure that DSA and BIOS/uEFI are at the latest level.

Related links

- IBM Support website
- Latest level of DSA
- Latest level of BMC/IMM

- **201-824-000 : Standalone Memory Test Aborted**

Node Interleave feature must be OFF. Go to Setup and disable Node Interleave option and then re-run the test.

Recoverable

No

Severity

Warning

Serviceable

No

Automatically notify support

No

User Response

Complete the following steps:

1. Perform the actions mentioned one at a time and try the test after each action.
2. If the problem remains, contact your technical-service representative.

3. Turn off the system and disconnect it from power. Wait for 45 seconds. Reseat DIMM(s). Reconnect it to power.
4. Make sure that DSA and BIOS/uEFI are at the latest level.

Related links

- IBM Support website
- Latest level of DSA
- Latest level of BMC/IMM

• 201-824-001 : Standalone Memory Test Aborted

Node Interleave feature must be OFF. Go to Setup and disable Node Interleave option and then re-run the test.

Recoverable

No

Severity

Warning

Serviceable

No

Automatically notify support

No

User Response

Complete the following steps:

1. Perform the actions mentioned one at a time and try the test after each action.
2. If the problem remains, contact your technical-service representative.
3. Turn off the system and disconnect it from power. Wait for 45 seconds. Reseat DIMM(s). Reconnect it to power.
4. Make sure that DSA and BIOS/uEFI are at the latest level.

Related links

- IBM Support website
- Latest level of DSA
- Latest level of BMC/IMM

• 201-824-002 : Standalone Memory Test Aborted

Node Interleave feature must be OFF. Go to Setup and disable Node Interleave option and then re-run the test.

Recoverable

No

Severity

Warning

Serviceable

No

Automatically notify support

No

User Response

Complete the following steps:

1. Perform the actions mentioned one at a time and try the test after each action.
2. If the problem remains, contact your technical-service representative.
3. Turn off the system and disconnect it from power. Wait for 45 seconds. Reseat DIMM(s). Reconnect it to power.
4. Make sure that DSA and BIOS/uEFI are at the latest level.

Related links

- IBM Support website
- Latest level of DSA
- Latest level of BMC/IMM

- **201-824-003 : Standalone Memory Test Aborted**

Node Interleave feature must be OFF. Go to Setup and disable Node Interleave option and then re-run the test.

Recoverable

No

Severity

Warning

Serviceable

No

Automatically notify support

No

User Response

Complete the following steps:

1. Perform the actions mentioned one at a time and try the test after each action.
2. If the problem remains, contact your technical-service representative.
3. Turn off the system and disconnect it from power. Wait for 45 seconds. Reseat DIMM(s). Reconnect it to power.
4. Make sure that DSA and BIOS/uEFI are at the latest level.

Related links

- IBM Support website
- Latest level of DSA
- Latest level of BMC/IMM

- **201-826-000 : Standalone Memory Test Aborted**

BIOS: Memory Controller has been disabled. Go to Setup and Enable Memory Controller.

Recoverable

No

Severity

Warning

Serviceable

No

Automatically notify support

No

User Response

Complete the following steps:

1. Perform the actions mentioned one at a time and try the test after each action.
2. If the problem remains, contact your technical-service representative.
3. Turn off the system and disconnect it from power. Wait for 45 seconds. Reseat DIMM(s). Reconnect it to power.
4. Make sure that DSA and BIOS/uEFI are at the latest level.

Related links

- IBM Support website
- Latest level of DSA
- Latest level of BMC/IMM

- **201-826-001 : Standalone Memory Test Aborted**

BIOS: Memory Controller has been disabled. Go to Setup and Enable Memory Controller.

Recoverable

No

Severity

Warning

Serviceable

No

Automatically notify support

No

User Response

Complete the following steps:

1. Perform the actions mentioned one at a time and try the test after each action.
2. If the problem remains, contact your technical-service representative.
3. Turn off the system and disconnect it from power. Wait for 45 seconds. Reseat DIMM(s). Reconnect it to power.
4. Make sure that DSA and BIOS/uEFI are at the latest level.

Related links

- IBM Support website
- Latest level of DSA
- Latest level of BMC/IMM

- **201-826-002 : Standalone Memory Test Aborted**

BIOS: Memory Controller has been disabled. Go to Setup and Enable Memory Controller.

Recoverable

No

Severity

Warning

Serviceable

No

Automatically notify support

No

User Response

Complete the following steps:

1. Perform the actions mentioned one at a time and try the test after each action.
2. If the problem remains, contact your technical-service representative.
3. Turn off the system and disconnect it from power. Wait for 45 seconds. Reseat DIMM(s). Reconnect it to power.
4. Make sure that DSA and BIOS/uEFI are at the latest level.

Related links

- IBM Support website
- Latest level of DSA
- Latest level of BMC/IMM

• **201-826-003 : Standalone Memory Test Aborted**

BIOS: Memory Controller has been disabled. Go to Setup and Enable Memory Controller.

Recoverable

No

Severity

Warning

Serviceable

No

Automatically notify support

No

User Response

Complete the following steps:

1. Perform the actions mentioned one at a time and try the test after each action.
2. If the problem remains, contact your technical-service representative.
3. Turn off the system and disconnect it from power. Wait for 45 seconds. Reseat DIMM(s). Reconnect it to power.
4. Make sure that DSA and BIOS/uEFI are at the latest level.

Related links

- IBM Support website
- Latest level of DSA

- Latest level of BMC/IMM

- **201-827-000 : Standalone Memory Test Aborted**

BIOS: ECC function has been disabled by BIOS. Go to Setup and enable ECC generation.

Recoverable

No

Severity

Warning

Serviceable

No

Automatically notify support

No

User Response

Complete the following steps:

1. Perform the actions mentioned one at a time and try the test after each action.
2. If the problem remains, contact your technical-service representative.
3. Turn off the system and disconnect it from power. Wait for 45 seconds. Reseat DIMM(s). Reconnect it to power.
4. Make sure that DSA and BIOS/uEFI are at the latest level.

Related links

- IBM Support website
- Latest level of DSA
- Latest level of BMC/IMM

- **201-827-001 : Standalone Memory Test Aborted**

BIOS: ECC function has been disabled by BIOS. Go to Setup and enable ECC generation.

Recoverable

No

Severity

Warning

Serviceable

No

Automatically notify support

No

User Response

Complete the following steps:

1. Perform the actions mentioned one at a time and try the test after each action.
2. If the problem remains, contact your technical-service representative.
3. Turn off the system and disconnect it from power. Wait for 45 seconds. Reseat DIMM(s). Reconnect it to power.
4. Make sure that DSA and BIOS/uEFI are at the latest level.

Related links

- IBM Support website
- Latest level of DSA
- Latest level of BMC/IMM

- **201-827-002 : Standalone Memory Test Aborted**

BIOS: ECC function has been disabled by BIOS. Go to Setup and enable ECC generation.

Recoverable

No

Severity

Warning

Serviceable

No

Automatically notify support

No

User Response

Complete the following steps:

1. Perform the actions mentioned one at a time and try the test after each action.
2. If the problem remains, contact your technical-service representative.
3. Turn off the system and disconnect it from power. Wait for 45 seconds. Reseat DIMM(s). Reconnect it to power.
4. Make sure that DSA and BIOS/uEFI are at the latest level.

Related links

- IBM Support website
- Latest level of DSA
- Latest level of BMC/IMM

- **201-827-003 : Standalone Memory Test Aborted**

BIOS: ECC function has been disabled by BIOS. Go to Setup and enable ECC generation.

Recoverable

No

Severity

Warning

Serviceable

No

Automatically notify support

No

User Response

Complete the following steps:

1. Perform the actions mentioned one at a time and try the test after each action.
2. If the problem remains, contact your technical-service representative.

3. Turn off the system and disconnect it from power. Wait for 45 seconds. Reseat DIMM(s). Reconnect it to power.
4. Make sure that DSA and BIOS/uEFI are at the latest level.

Related links

- IBM Support website
- Latest level of DSA
- Latest level of BMC/IMM

- **201-844-000 : Standalone Memory Test Aborted**

Chipset Error: Problem in masking MSR machine check control MASK registers.

Recoverable

No

Severity

Warning

Serviceable

No

Automatically notify support

No

User Response

Complete the following steps:

1. Perform the actions mentioned one at a time and try the test after each action.
2. If the problem remains, contact your technical-service representative.
3. Turn off the system and disconnect it from power. Wait for 45 seconds. Reseat DIMM(s). Reconnect it to power.
4. Make sure that DSA and BIOS/uEFI are at the latest level.

Related links

- IBM Support website
- Latest level of DSA
- Latest level of BMC/IMM

- **201-844-001 : Standalone Memory Test Aborted**

Chipset Error: Problem in masking MSR machine check control MASK registers.

Recoverable

No

Severity

Warning

Serviceable

No

Automatically notify support

No

User Response

Complete the following steps:

1. Perform the actions mentioned one at a time and try the test after each action.
2. If the problem remains, contact your technical-service representative.
3. Turn off the system and disconnect it from power. Wait for 45 seconds. Reseat DIMM(s). Reconnect it to power.
4. Make sure that DSA and BIOS/uEFI are at the latest level.

Related links

- IBM Support website
- Latest level of DSA
- Latest level of BMC/IMM

• 201-844-002 : Standalone Memory Test Aborted

Chipset Error: Problem in masking MSR machine check control MASK registers.

Recoverable

No

Severity

Warning

Serviceable

No

Automatically notify support

No

User Response

Complete the following steps:

1. Perform the actions mentioned one at a time and try the test after each action.
2. If the problem remains, contact your technical-service representative.
3. Turn off the system and disconnect it from power. Wait for 45 seconds. Reseat DIMM(s). Reconnect it to power.
4. Make sure that DSA and BIOS/uEFI are at the latest level.

Related links

- IBM Support website
- Latest level of DSA
- Latest level of BMC/IMM

• 201-844-003 : Standalone Memory Test Aborted

Chipset Error: Problem in masking MSR machine check control MASK registers.

Recoverable

No

Severity

Warning

Serviceable

No

Automatically notify support

No

User Response

Complete the following steps:

1. Perform the actions mentioned one at a time and try the test after each action.
2. If the problem remains, contact your technical-service representative.
3. Turn off the system and disconnect it from power. Wait for 45 seconds. Reseat DIMM(s). Reconnect it to power.
4. Make sure that DSA and BIOS/uEFI are at the latest level.

Related links

- IBM Support website
- Latest level of DSA
- Latest level of BMC/IMM

- **201-845-000 : Standalone Memory Test Aborted**

Chipset Error: Problem clearing MSR machine check control registers.

Recoverable

No

Severity

Warning

Serviceable

No

Automatically notify support

No

User Response

Complete the following steps:

1. Perform the actions mentioned one at a time and try the test after each action.
2. If the problem remains, contact your technical-service representative.
3. Turn off the system and disconnect it from power. Wait for 45 seconds. Reseat DIMM(s). Reconnect it to power.
4. Make sure that DSA and BIOS/uEFI are at the latest level.

Related links

- IBM Support website
- Latest level of DSA
- Latest level of BMC/IMM

- **201-845-001 : Standalone Memory Test Aborted**

Chipset Error: Problem clearing MSR machine check control registers.

Recoverable

No

Severity

Warning

Serviceable

No

Automatically notify support

No

User Response

Complete the following steps:

1. Perform the actions mentioned one at a time and try the test after each action.
2. If the problem remains, contact your technical-service representative.
3. Turn off the system and disconnect it from power. Wait for 45 seconds. Reseat DIMM(s). Reconnect it to power.
4. Make sure that DSA and BIOS/uEFI are at the latest level.

Related links

- IBM Support website
- Latest level of DSA
- Latest level of BMC/IMM

• 201-845-002 : Standalone Memory Test Aborted

Chipset Error: Problem clearing MSR machine check control registers.

Recoverable

No

Severity

Warning

Serviceable

No

Automatically notify support

No

User Response

Complete the following steps:

1. Perform the actions mentioned one at a time and try the test after each action.
2. If the problem remains, contact your technical-service representative.
3. Turn off the system and disconnect it from power. Wait for 45 seconds. Reseat DIMM(s). Reconnect it to power.
4. Make sure that DSA and BIOS/uEFI are at the latest level.

Related links

- IBM Support website
- Latest level of DSA
- Latest level of BMC/IMM

- **201-845-003 : Standalone Memory Test Aborted**

Chipset Error: Problem clearing MSR machine check control registers.

Recoverable

No

Severity

Warning

Serviceable

No

Automatically notify support

No

User Response

Complete the following steps:

1. Perform the actions mentioned one at a time and try the test after each action.
2. If the problem remains, contact your technical-service representative.
3. Turn off the system and disconnect it from power. Wait for 45 seconds. Reseat DIMM(s). Reconnect it to power.
4. Make sure that DSA and BIOS/uEFI are at the latest level.

Related links

- IBM Support website
- Latest level of DSA
- Latest level of BMC/IMM

- **201-859-000 : Standalone Memory Test Aborted**

INVALID XSECSRAT type.

Recoverable

No

Severity

Warning

Serviceable

No

Automatically notify support

No

User Response

Complete the following steps:

1. Perform the actions mentioned one at a time and try the test after each action.
2. If the problem remains, contact your technical-service representative.
3. Turn off the system and disconnect it from power. Wait for 45 seconds. Reseat DIMM(s). Reconnect it to power.
4. Make sure that DSA and BIOS/uEFI are at the latest level.

Related links

- IBM Support website
- Latest level of DSA
- Latest level of BMC/IMM

- **201-859-001 : Standalone Memory Test Aborted**

INVALID XSECSRAT type.

Recoverable

No

Severity

Warning

Serviceable

No

Automatically notify support

No

User Response

Complete the following steps:

1. Perform the actions mentioned one at a time and try the test after each action.
2. If the problem remains, contact your technical-service representative.
3. Turn off the system and disconnect it from power. Wait for 45 seconds. Reseat DIMM(s). Reconnect it to power.
4. Make sure that DSA and BIOS/uEFI are at the latest level.

Related links

- IBM Support website
- Latest level of DSA
- Latest level of BMC/IMM

- **201-859-002 : Standalone Memory Test Aborted**

INVALID XSECSRAT type.

Recoverable

No

Severity

Warning

Serviceable

No

Automatically notify support

No

User Response

Complete the following steps:

1. Perform the actions mentioned one at a time and try the test after each action.
2. If the problem remains, contact your technical-service representative.

3. Turn off the system and disconnect it from power. Wait for 45 seconds. Reseat DIMM(s). Reconnect it to power.
4. Make sure that DSA and BIOS/uEFI are at the latest level.

Related links

- IBM Support website
- Latest level of DSA
- Latest level of BMC/IMM

• 201-859-003 : Standalone Memory Test Aborted

INVALID XSECSRAT type.

Recoverable

No

Severity

Warning

Serviceable

No

Automatically notify support

No

User Response

Complete the following steps:

1. Perform the actions mentioned one at a time and try the test after each action.
2. If the problem remains, contact your technical-service representative.
3. Turn off the system and disconnect it from power. Wait for 45 seconds. Reseat DIMM(s). Reconnect it to power.
4. Make sure that DSA and BIOS/uEFI are at the latest level.

Related links

- IBM Support website
- Latest level of DSA
- Latest level of BMC/IMM

• 201-860-000 : Standalone Memory Test Aborted

No OEM0 type 1 found.

Recoverable

No

Severity

Warning

Serviceable

No

Automatically notify support

No

User Response

Complete the following steps:

1. Perform the actions mentioned one at a time and try the test after each action.
2. If the problem remains, contact your technical-service representative.
3. Turn off the system and disconnect it from power. Wait for 45 seconds. Reseat DIMM(s). Reconnect it to power.
4. Make sure that DSA and BIOS/uEFI are at the latest level.

Related links

- IBM Support website
- Latest level of DSA
- Latest level of BMC/IMM

• 201-860-001 : Standalone Memory Test Aborted

No OEM0 type 1 found.

Recoverable

No

Severity

Warning

Serviceable

No

Automatically notify support

No

User Response

Complete the following steps:

1. Perform the actions mentioned one at a time and try the test after each action.
2. If the problem remains, contact your technical-service representative.
3. Turn off the system and disconnect it from power. Wait for 45 seconds. Reseat DIMM(s). Reconnect it to power.
4. Make sure that DSA and BIOS/uEFI are at the latest level.

Related links

- IBM Support website
- Latest level of DSA
- Latest level of BMC/IMM

• 201-860-002 : Standalone Memory Test Aborted

No OEM0 type 1 found.

Recoverable

No

Severity

Warning

Serviceable

No

Automatically notify support

No

User Response

Complete the following steps:

1. Perform the actions mentioned one at a time and try the test after each action.
2. If the problem remains, contact your technical-service representative.
3. Turn off the system and disconnect it from power. Wait for 45 seconds. Reseat DIMM(s). Reconnect it to power.
4. Make sure that DSA and BIOS/uEFI are at the latest level.

Related links

- IBM Support website
- Latest level of DSA
- Latest level of BMC/IMM

• 201-860-003 : Standalone Memory Test Aborted

No OEM0 type 1 found.

Recoverable

No

Severity

Warning

Serviceable

No

Automatically notify support

No

User Response

Complete the following steps:

1. Perform the actions mentioned one at a time and try the test after each action.
2. If the problem remains, contact your technical-service representative.
3. Turn off the system and disconnect it from power. Wait for 45 seconds. Reseat DIMM(s). Reconnect it to power.
4. Make sure that DSA and BIOS/uEFI are at the latest level.

Related links

- IBM Support website
- Latest level of DSA
- Latest level of BMC/IMM

• 201-861-000 : Standalone Memory Test Aborted

No SRAT type 1 found.

Recoverable

No

Severity

Warning

Serviceable

No

Automatically notify support

No

User Response

Complete the following steps:

1. Perform the actions mentioned one at a time and try the test after each action.
2. If the problem remains, contact your technical-service representative.
3. Turn off the system and disconnect it from power. Wait for 45 seconds. Reseat DIMM(s). Reconnect it to power.
4. Make sure that DSA and BIOS/uEFI are at the latest level.

Related links

- IBM Support website
- Latest level of DSA
- Latest level of BMC/IMM

• 201-861-001 : Standalone Memory Test Aborted

No SRAT type 1 found.

Recoverable

No

Severity

Warning

Serviceable

No

Automatically notify support

No

User Response

Complete the following steps:

1. Perform the actions mentioned one at a time and try the test after each action.
2. If the problem remains, contact your technical-service representative.
3. Turn off the system and disconnect it from power. Wait for 45 seconds. Reseat DIMM(s). Reconnect it to power.
4. Make sure that DSA and BIOS/uEFI are at the latest level.

Related links

- IBM Support website
- Latest level of DSA
- Latest level of BMC/IMM

- **201-861-002 : Standalone Memory Test Aborted**

No SRAT type 1 found.

Recoverable

No

Severity

Warning

Serviceable

No

Automatically notify support

No

User Response

Complete the following steps:

1. Perform the actions mentioned one at a time and try the test after each action.
2. If the problem remains, contact your technical-service representative.
3. Turn off the system and disconnect it from power. Wait for 45 seconds. Reseat DIMM(s). Reconnect it to power.
4. Make sure that DSA and BIOS/uEFI are at the latest level.

Related links

- IBM Support website
- Latest level of DSA
- Latest level of BMC/IMM

- **201-861-003 : Standalone Memory Test Aborted**

No SRAT type 1 found.

Recoverable

No

Severity

Warning

Serviceable

No

Automatically notify support

No

User Response

Complete the following steps:

1. Perform the actions mentioned one at a time and try the test after each action.
2. If the problem remains, contact your technical-service representative.
3. Turn off the system and disconnect it from power. Wait for 45 seconds. Reseat DIMM(s). Reconnect it to power.
4. Make sure that DSA and BIOS/uEFI are at the latest level.

Related links

- IBM Support website
- Latest level of DSA
- Latest level of BMC/IMM

- **201-862-000 : Standalone Memory Test Aborted**

No OEM1 structure found.

Recoverable

No

Severity

Warning

Serviceable

No

Automatically notify support

No

User Response

Complete the following steps:

1. Perform the actions mentioned one at a time and try the test after each action.
2. If the problem remains, contact your technical-service representative.
3. Turn off the system and disconnect it from power. Wait for 45 seconds. Reseat DIMM(s). Reconnect it to power.
4. Make sure that DSA and BIOS/uEFI are at the latest level.

Related links

- IBM Support website
- Latest level of DSA
- Latest level of BMC/IMM

- **201-862-001 : Standalone Memory Test Aborted**

No OEM1 structure found.

Recoverable

No

Severity

Warning

Serviceable

No

Automatically notify support

No

User Response

Complete the following steps:

1. Perform the actions mentioned one at a time and try the test after each action.
2. If the problem remains, contact your technical-service representative.

3. Turn off the system and disconnect it from power. Wait for 45 seconds. Reseat DIMM(s). Reconnect it to power.
4. Make sure that DSA and BIOS/uEFI are at the latest level.

Related links

- IBM Support website
- Latest level of DSA
- Latest level of BMC/IMM

- **201-862-002 : Standalone Memory Test Aborted**

No OEM1 structure found.

Recoverable

No

Severity

Warning

Serviceable

No

Automatically notify support

No

User Response

Complete the following steps:

1. Perform the actions mentioned one at a time and try the test after each action.
2. If the problem remains, contact your technical-service representative.
3. Turn off the system and disconnect it from power. Wait for 45 seconds. Reseat DIMM(s). Reconnect it to power.
4. Make sure that DSA and BIOS/uEFI are at the latest level.

Related links

- IBM Support website
- Latest level of DSA
- Latest level of BMC/IMM

- **201-862-003 : Standalone Memory Test Aborted**

No OEM1 structure found.

Recoverable

No

Severity

Warning

Serviceable

No

Automatically notify support

No

User Response

Complete the following steps:

1. Perform the actions mentioned one at a time and try the test after each action.
2. If the problem remains, contact your technical-service representative.
3. Turn off the system and disconnect it from power. Wait for 45 seconds. Reseat DIMM(s). Reconnect it to power.
4. Make sure that DSA and BIOS/uEFI are at the latest level.

Related links

- IBM Support website
- Latest level of DSA
- Latest level of BMC/IMM

• 201-863-000 : Standalone Memory Test Aborted

No IBMERROR key in OEM1 structure.

Recoverable

No

Severity

Warning

Serviceable

No

Automatically notify support

No

User Response

Complete the following steps:

1. Perform the actions mentioned one at a time and try the test after each action.
2. If the problem remains, contact your technical-service representative.
3. Turn off the system and disconnect it from power. Wait for 45 seconds. Reseat DIMM(s). Reconnect it to power.
4. Make sure that DSA and BIOS/uEFI are at the latest level.

Related links

- IBM Support website
- Latest level of DSA
- Latest level of BMC/IMM

• 201-863-001 : Standalone Memory Test Aborted

No IBMERROR key in OEM1 structure.

Recoverable

No

Severity

Warning

Serviceable

No

Automatically notify support

No

User Response

Complete the following steps:

1. Perform the actions mentioned one at a time and try the test after each action.
2. If the problem remains, contact your technical-service representative.
3. Turn off the system and disconnect it from power. Wait for 45 seconds. Reseat DIMM(s). Reconnect it to power.
4. Make sure that DSA and BIOS/uEFI are at the latest level.

Related links

- IBM Support website
- Latest level of DSA
- Latest level of BMC/IMM

- **201-863-002 : Standalone Memory Test Aborted**

No IBMERROR key in OEM1 structure.

Recoverable

No

Severity

Warning

Serviceable

No

Automatically notify support

No

User Response

Complete the following steps:

1. Perform the actions mentioned one at a time and try the test after each action.
2. If the problem remains, contact your technical-service representative.
3. Turn off the system and disconnect it from power. Wait for 45 seconds. Reseat DIMM(s). Reconnect it to power.
4. Make sure that DSA and BIOS/uEFI are at the latest level.

Related links

- IBM Support website
- Latest level of DSA
- Latest level of BMC/IMM

- **201-863-003 : Standalone Memory Test Aborted**

No IBMERROR key in OEM1 structure.

Recoverable

No

Severity

Warning

Serviceable

No

Automatically notify support

No

User Response

Complete the following steps:

1. Perform the actions mentioned one at a time and try the test after each action.
2. If the problem remains, contact your technical-service representative.
3. Turn off the system and disconnect it from power. Wait for 45 seconds. Reseat DIMM(s). Reconnect it to power.
4. Make sure that DSA and BIOS/uEFI are at the latest level.

Related links

- IBM Support website
- Latest level of DSA
- Latest level of BMC/IMM

• 201-864-000 : Standalone Memory Test Aborted

No GAS located in OEM1.

Recoverable

No

Severity

Warning

Serviceable

No

Automatically notify support

No

User Response

Complete the following steps:

1. Perform the actions mentioned one at a time and try the test after each action.
2. If the problem remains, contact your technical-service representative.
3. Turn off the system and disconnect it from power. Wait for 45 seconds. Reseat DIMM(s). Reconnect it to power.
4. Make sure that DSA and BIOS/uEFI are at the latest level.

Related links

- IBM Support website
- Latest level of DSA
- Latest level of BMC/IMM

- **201-864-001 : Standalone Memory Test Aborted**

No GAS located in OEM1.

Recoverable

No

Severity

Warning

Serviceable

No

Automatically notify support

No

User Response

Complete the following steps:

1. Perform the actions mentioned one at a time and try the test after each action.
2. If the problem remains, contact your technical-service representative.
3. Turn off the system and disconnect it from power. Wait for 45 seconds. Reseat DIMM(s). Reconnect it to power.
4. Make sure that DSA and BIOS/uEFI are at the latest level.

Related links

- IBM Support website
- Latest level of DSA
- Latest level of BMC/IMM

- **201-864-002 : Standalone Memory Test Aborted**

No GAS located in OEM1.

Recoverable

No

Severity

Warning

Serviceable

No

Automatically notify support

No

User Response

Complete the following steps:

1. Perform the actions mentioned one at a time and try the test after each action.
2. If the problem remains, contact your technical-service representative.
3. Turn off the system and disconnect it from power. Wait for 45 seconds. Reseat DIMM(s). Reconnect it to power.
4. Make sure that DSA and BIOS/uEFI are at the latest level.

Related links

- IBM Support website
- Latest level of DSA
- Latest level of BMC/IMM

- **201-864-003 : Standalone Memory Test Aborted**

No GAS located in OEM1.

Recoverable

No

Severity

Warning

Serviceable

No

Automatically notify support

No

User Response

Complete the following steps:

1. Perform the actions mentioned one at a time and try the test after each action.
2. If the problem remains, contact your technical-service representative.
3. Turn off the system and disconnect it from power. Wait for 45 seconds. Reseat DIMM(s). Reconnect it to power.
4. Make sure that DSA and BIOS/uEFI are at the latest level.

Related links

- IBM Support website
- Latest level of DSA
- Latest level of BMC/IMM

- **201-865-000 : Standalone Memory Test Aborted**

No XSECSRAT key in OEM0 structure.

Recoverable

No

Severity

Warning

Serviceable

No

Automatically notify support

No

User Response

Complete the following steps:

1. Perform the actions mentioned one at a time and try the test after each action.
2. If the problem remains, contact your technical-service representative.

3. Turn off the system and disconnect it from power. Wait for 45 seconds. Reseat DIMM(s). Reconnect it to power.
4. Make sure that DSA and BIOS/uEFI are at the latest level.

Related links

- IBM Support website
- Latest level of DSA
- Latest level of BMC/IMM

• 201-865-001 : Standalone Memory Test Aborted

No XSECSRAT key in OEM0 structure.

Recoverable

No

Severity

Warning

Serviceable

No

Automatically notify support

No

User Response

Complete the following steps:

1. Perform the actions mentioned one at a time and try the test after each action.
2. If the problem remains, contact your technical-service representative.
3. Turn off the system and disconnect it from power. Wait for 45 seconds. Reseat DIMM(s). Reconnect it to power.
4. Make sure that DSA and BIOS/uEFI are at the latest level.

Related links

- IBM Support website
- Latest level of DSA
- Latest level of BMC/IMM

• 201-865-002 : Standalone Memory Test Aborted

No XSECSRAT key in OEM0 structure.

Recoverable

No

Severity

Warning

Serviceable

No

Automatically notify support

No

User Response

Complete the following steps:

1. Perform the actions mentioned one at a time and try the test after each action.
2. If the problem remains, contact your technical-service representative.
3. Turn off the system and disconnect it from power. Wait for 45 seconds. Reseat DIMM(s). Reconnect it to power.
4. Make sure that DSA and BIOS/uEFI are at the latest level.

Related links

- IBM Support website
- Latest level of DSA
- Latest level of BMC/IMM

• 201-865-003 : Standalone Memory Test Aborted

No XSECSRAT key in OEM0 structure.

Recoverable

No

Severity

Warning

Serviceable

No

Automatically notify support

No

User Response

Complete the following steps:

1. Perform the actions mentioned one at a time and try the test after each action.
2. If the problem remains, contact your technical-service representative.
3. Turn off the system and disconnect it from power. Wait for 45 seconds. Reseat DIMM(s). Reconnect it to power.
4. Make sure that DSA and BIOS/uEFI are at the latest level.

Related links

- IBM Support website
- Latest level of DSA
- Latest level of BMC/IMM

• 201-866-000 : Standalone Memory Test Aborted

EFI-SAL Invalid parameter from GetMemoryMap function.

Recoverable

No

Severity

Warning

Serviceable

No

Automatically notify support

No

User Response

Complete the following steps:

1. Perform the actions mentioned one at a time and try the test after each action.
2. If the problem remains, contact your technical-service representative.
3. Turn off the system and disconnect it from power. Wait for 45 seconds. Reseat DIMM(s). Reconnect it to power.
4. Make sure that DSA and BIOS/uEFI are at the latest level.

Related links

- IBM Support website
- Latest level of DSA
- Latest level of BMC/IMM

- **201-866-001 : Standalone Memory Test Aborted**

EFI-SAL Invalid parameter from GetMemoryMap function.

Recoverable

No

Severity

Warning

Serviceable

No

Automatically notify support

No

User Response

Complete the following steps:

1. Perform the actions mentioned one at a time and try the test after each action.
2. If the problem remains, contact your technical-service representative.
3. Turn off the system and disconnect it from power. Wait for 45 seconds. Reseat DIMM(s). Reconnect it to power.
4. Make sure that DSA and BIOS/uEFI are at the latest level.

Related links

- IBM Support website
- Latest level of DSA
- Latest level of BMC/IMM

- **201-866-002 : Standalone Memory Test Aborted**

EFI-SAL Invalid parameter from GetMemoryMap function.

Recoverable

No

Severity

Warning

Serviceable

No

Automatically notify support

No

User Response

Complete the following steps:

1. Perform the actions mentioned one at a time and try the test after each action.
2. If the problem remains, contact your technical-service representative.
3. Turn off the system and disconnect it from power. Wait for 45 seconds. Reseat DIMM(s). Reconnect it to power.
4. Make sure that DSA and BIOS/uEFI are at the latest level.

Related links

- IBM Support website
- Latest level of DSA
- Latest level of BMC/IMM

• 201-866-003 : Standalone Memory Test Aborted

EFI-SAL Invalid parameter from GetMemoryMap function.

Recoverable

No

Severity

Warning

Serviceable

No

Automatically notify support

No

User Response

Complete the following steps:

1. Perform the actions mentioned one at a time and try the test after each action.
2. If the problem remains, contact your technical-service representative.
3. Turn off the system and disconnect it from power. Wait for 45 seconds. Reseat DIMM(s). Reconnect it to power.
4. Make sure that DSA and BIOS/uEFI are at the latest level.

Related links

- IBM Support website
- Latest level of DSA
- Latest level of BMC/IMM

- **201-867-000 : Standalone Memory Test Aborted**

EFI/SAL: Buffer not allocated.

Recoverable

No

Severity

Warning

Serviceable

No

Automatically notify support

No

User Response

Complete the following steps:

1. Perform the actions mentioned one at a time and try the test after each action.
2. If the problem remains, contact your technical-service representative.
3. Turn off the system and disconnect it from power. Wait for 45 seconds. Reseat DIMM(s). Reconnect it to power.
4. Make sure that DSA and BIOS/uEFI are at the latest level.

Related links

- IBM Support website
- Latest level of DSA
- Latest level of BMC/IMM

- **201-867-001 : Standalone Memory Test Aborted**

EFI/SAL: Buffer not allocated.

Recoverable

No

Severity

Warning

Serviceable

No

Automatically notify support

No

User Response

Complete the following steps:

1. Perform the actions mentioned one at a time and try the test after each action.
2. If the problem remains, contact your technical-service representative.
3. Turn off the system and disconnect it from power. Wait for 45 seconds. Reseat DIMM(s). Reconnect it to power.
4. Make sure that DSA and BIOS/uEFI are at the latest level.

Related links

- IBM Support website
- Latest level of DSA
- Latest level of BMC/IMM

- **201-867-002 : Standalone Memory Test Aborted**

EFI/SAL: Buffer not allocated.

Recoverable

No

Severity

Warning

Serviceable

No

Automatically notify support

No

User Response

Complete the following steps:

1. Perform the actions mentioned one at a time and try the test after each action.
2. If the problem remains, contact your technical-service representative.
3. Turn off the system and disconnect it from power. Wait for 45 seconds. Reseat DIMM(s). Reconnect it to power.
4. Make sure that DSA and BIOS/uEFI are at the latest level.

Related links

- IBM Support website
- Latest level of DSA
- Latest level of BMC/IMM

- **201-867-003 : Standalone Memory Test Aborted**

EFI/SAL: Buffer not allocated.

Recoverable

No

Severity

Warning

Serviceable

No

Automatically notify support

No

User Response

Complete the following steps:

1. Perform the actions mentioned one at a time and try the test after each action.
2. If the problem remains, contact your technical-service representative.

3. Turn off the system and disconnect it from power. Wait for 45 seconds. Reseat DIMM(s). Reconnect it to power.
4. Make sure that DSA and BIOS/uEFI are at the latest level.

Related links

- IBM Support website
- Latest level of DSA
- Latest level of BMC/IMM

- **201-868-000 : Standalone Memory Test Aborted**

EFI/SAL: Buffer allocated in GetMemoryMap too small.

Recoverable

No

Severity

Warning

Serviceable

No

Automatically notify support

No

User Response

Complete the following steps:

1. Perform the actions mentioned one at a time and try the test after each action.
2. If the problem remains, contact your technical-service representative.
3. Turn off the system and disconnect it from power. Wait for 45 seconds. Reseat DIMM(s). Reconnect it to power.
4. Make sure that DSA and BIOS/uEFI are at the latest level.

Related links

- IBM Support website
- Latest level of DSA
- Latest level of BMC/IMM

- **201-868-001 : Standalone Memory Test Aborted**

EFI/SAL: Buffer allocated in GetMemoryMap too small.

Recoverable

No

Severity

Warning

Serviceable

No

Automatically notify support

No

User Response

Complete the following steps:

1. Perform the actions mentioned one at a time and try the test after each action.
2. If the problem remains, contact your technical-service representative.
3. Turn off the system and disconnect it from power. Wait for 45 seconds. Reseat DIMM(s). Reconnect it to power.
4. Make sure that DSA and BIOS/uEFI are at the latest level.

Related links

- IBM Support website
- Latest level of DSA
- Latest level of BMC/IMM

- **201-868-002 : Standalone Memory Test Aborted**

EFI/SAL: Buffer allocated in GetMemoryMap too small.

Recoverable

No

Severity

Warning

Serviceable

No

Automatically notify support

No

User Response

Complete the following steps:

1. Perform the actions mentioned one at a time and try the test after each action.
2. If the problem remains, contact your technical-service representative.
3. Turn off the system and disconnect it from power. Wait for 45 seconds. Reseat DIMM(s). Reconnect it to power.
4. Make sure that DSA and BIOS/uEFI are at the latest level.

Related links

- IBM Support website
- Latest level of DSA
- Latest level of BMC/IMM

- **201-868-003 : Standalone Memory Test Aborted**

EFI/SAL: Buffer allocated in GetMemoryMap too small.

Recoverable

No

Severity

Warning

Serviceable

No

Automatically notify support

No

User Response

Complete the following steps:

1. Perform the actions mentioned one at a time and try the test after each action.
2. If the problem remains, contact your technical-service representative.
3. Turn off the system and disconnect it from power. Wait for 45 seconds. Reseat DIMM(s). Reconnect it to power.
4. Make sure that DSA and BIOS/uEFI are at the latest level.

Related links

- IBM Support website
- Latest level of DSA
- Latest level of BMC/IMM

- **201-869-000 : Standalone Memory Test Aborted**

EFI/SAL Invalid parameter from GetMemoryMap function.

Recoverable

No

Severity

Warning

Serviceable

No

Automatically notify support

No

User Response

Complete the following steps:

1. Perform the actions mentioned one at a time and try the test after each action.
2. If the problem remains, contact your technical-service representative.
3. Turn off the system and disconnect it from power. Wait for 45 seconds. Reseat DIMM(s). Reconnect it to power.
4. Make sure that DSA and BIOS/uEFI are at the latest level.

Related links

- IBM Support website
- Latest level of DSA
- Latest level of BMC/IMM

- **201-869-001 : Standalone Memory Test Aborted**

EFI/SAL Invalid parameter from GetMemoryMap function.

Recoverable

No

Severity

Warning

Serviceable

No

Automatically notify support

No

User Response

Complete the following steps:

1. Perform the actions mentioned one at a time and try the test after each action.
2. If the problem remains, contact your technical-service representative.
3. Turn off the system and disconnect it from power. Wait for 45 seconds. Reseat DIMM(s). Reconnect it to power.
4. Make sure that DSA and BIOS/uEFI are at the latest level.

Related links

- IBM Support website
- Latest level of DSA
- Latest level of BMC/IMM

- **201-869-002 : Standalone Memory Test Aborted**

EFI/SAL Invalid parameter from GetMemoryMap function.

Recoverable

No

Severity

Warning

Serviceable

No

Automatically notify support

No

User Response

Complete the following steps:

1. Perform the actions mentioned one at a time and try the test after each action.
2. If the problem remains, contact your technical-service representative.
3. Turn off the system and disconnect it from power. Wait for 45 seconds. Reseat DIMM(s). Reconnect it to power.
4. Make sure that DSA and BIOS/uEFI are at the latest level.

Related links

- IBM Support website
- Latest level of DSA
- Latest level of BMC/IMM

- **201-869-003 : Standalone Memory Test Aborted**

EFI/SAL Invalid parameter from GetMemoryMap function.

Recoverable

No

Severity

Warning

Serviceable

No

Automatically notify support

No

User Response

Complete the following steps:

1. Perform the actions mentioned one at a time and try the test after each action.
2. If the problem remains, contact your technical-service representative.
3. Turn off the system and disconnect it from power. Wait for 45 seconds. Reseat DIMM(s). Reconnect it to power.
4. Make sure that DSA and BIOS/uEFI are at the latest level.

Related links

- IBM Support website
- Latest level of DSA
- Latest level of BMC/IMM

- **201-870-000 : Standalone Memory Test Aborted**

CPU Doamin in ACPI not valid.

Recoverable

No

Severity

Warning

Serviceable

No

Automatically notify support

No

User Response

Complete the following steps:

1. Perform the actions mentioned one at a time and try the test after each action.
2. If the problem remains, contact your technical-service representative.
3. Turn off the system and disconnect it from power. Wait for 45 seconds. Reseat DIMM(s). Reconnect it to power.
4. Make sure that DSA and BIOS/uEFI are at the latest level.

Related links

- IBM Support website
- Latest level of DSA
- Latest level of BMC/IMM

- **201-870-001 : Standalone Memory Test Aborted**

CPU Doamin in ACPI not valid.

Recoverable

No

Severity

Warning

Serviceable

No

Automatically notify support

No

User Response

Complete the following steps:

1. Perform the actions mentioned one at a time and try the test after each action.
2. If the problem remains, contact your technical-service representative.
3. Turn off the system and disconnect it from power. Wait for 45 seconds. Reseat DIMM(s). Reconnect it to power.
4. Make sure that DSA and BIOS/uEFI are at the latest level.

Related links

- IBM Support website
- Latest level of DSA
- Latest level of BMC/IMM

- **201-870-002 : Standalone Memory Test Aborted**

CPU Doamin in ACPI not valid.

Recoverable

No

Severity

Warning

Serviceable

No

Automatically notify support

No

User Response

Complete the following steps:

1. Perform the actions mentioned one at a time and try the test after each action.
2. If the problem remains, contact your technical-service representative.

3. Turn off the system and disconnect it from power. Wait for 45 seconds. Reseat DIMM(s). Reconnect it to power.
4. Make sure that DSA and BIOS/uEFI are at the latest level.

Related links

- IBM Support website
- Latest level of DSA
- Latest level of BMC/IMM

- **201-870-003 : Standalone Memory Test Aborted**

CPU Doamin in ACPI not valid.

Recoverable

No

Severity

Warning

Serviceable

No

Automatically notify support

No

User Response

Complete the following steps:

1. Perform the actions mentioned one at a time and try the test after each action.
2. If the problem remains, contact your technical-service representative.
3. Turn off the system and disconnect it from power. Wait for 45 seconds. Reseat DIMM(s). Reconnect it to power.
4. Make sure that DSA and BIOS/uEFI are at the latest level.

Related links

- IBM Support website
- Latest level of DSA
- Latest level of BMC/IMM

- **201-871-000 : Standalone Memory Test Aborted**

Data Mis-compare encountered.

Recoverable

No

Severity

Warning

Serviceable

No

Automatically notify support

No

User Response

Complete the following steps:

1. Perform the actions mentioned one at a time and try the test after each action.
2. If the problem remains, contact your technical-service representative.
3. Turn off the system and disconnect it from power. Wait for 45 seconds. Reseat DIMM(s). Reconnect it to power.
4. Make sure that DSA and BIOS/uEFI are at the latest level.

Related links

- IBM Support website
- Latest level of DSA
- Latest level of BMC/IMM

• 201-871-001 : Standalone Memory Test Aborted

Data Mis-compare encountered.

Recoverable

No

Severity

Warning

Serviceable

No

Automatically notify support

No

User Response

Complete the following steps:

1. Perform the actions mentioned one at a time and try the test after each action.
2. If the problem remains, contact your technical-service representative.
3. Turn off the system and disconnect it from power. Wait for 45 seconds. Reseat DIMM(s). Reconnect it to power.
4. Make sure that DSA and BIOS/uEFI are at the latest level.

Related links

- IBM Support website
- Latest level of DSA
- Latest level of BMC/IMM

• 201-871-002 : Standalone Memory Test Aborted

Data Mis-compare encountered.

Recoverable

No

Severity

Warning

Serviceable

No

Automatically notify support

No

User Response

Complete the following steps:

1. Perform the actions mentioned one at a time and try the test after each action.
2. If the problem remains, contact your technical-service representative.
3. Turn off the system and disconnect it from power. Wait for 45 seconds. Reseat DIMM(s). Reconnect it to power.
4. Make sure that DSA and BIOS/uEFI are at the latest level.

Related links

- IBM Support website
- Latest level of DSA
- Latest level of BMC/IMM

- **201-871-003 : Standalone Memory Test Aborted**

Data Mis-compare encountered.

Recoverable

No

Severity

Warning

Serviceable

No

Automatically notify support

No

User Response

Complete the following steps:

1. Perform the actions mentioned one at a time and try the test after each action.
2. If the problem remains, contact your technical-service representative.
3. Turn off the system and disconnect it from power. Wait for 45 seconds. Reseat DIMM(s). Reconnect it to power.
4. Make sure that DSA and BIOS/uEFI are at the latest level.

Related links

- IBM Support website
- Latest level of DSA
- Latest level of BMC/IMM

- **201-877-000 : Standalone Memory Test Aborted**

BIOS: Sparring in Extended PCI reg. must be OFF. Go to setup and disable sparring.

Recoverable

No

Severity

Warning

Serviceable

No

Automatically notify support

No

User Response

Complete the following steps:

1. Perform the actions mentioned one at a time and try the test after each action.
2. If the problem remains, contact your technical-service representative.
3. Turn off the system and disconnect it from power. Wait for 45 seconds. Reseat DIMM(s). Reconnect it to power.
4. Make sure that DSA and BIOS/uEFI are at the latest level.

Related links

- IBM Support website
- Latest level of DSA
- Latest level of BMC/IMM

• 201-877-001 : Standalone Memory Test Aborted

BIOS: Sparring in Extended PCI reg. must be OFF. Go to setup and disable sparring.

Recoverable

No

Severity

Warning

Serviceable

No

Automatically notify support

No

User Response

Complete the following steps:

1. Perform the actions mentioned one at a time and try the test after each action.
2. If the problem remains, contact your technical-service representative.
3. Turn off the system and disconnect it from power. Wait for 45 seconds. Reseat DIMM(s). Reconnect it to power.
4. Make sure that DSA and BIOS/uEFI are at the latest level.

Related links

- IBM Support website
- Latest level of DSA
- Latest level of BMC/IMM

- **201-877-002 : Standalone Memory Test Aborted**

BIOS: Sparing in Extended PCI reg. must be OFF. Go to setup and disable sparing.

Recoverable

No

Severity

Warning

Serviceable

No

Automatically notify support

No

User Response

Complete the following steps:

1. Perform the actions mentioned one at a time and try the test after each action.
2. If the problem remains, contact your technical-service representative.
3. Turn off the system and disconnect it from power. Wait for 45 seconds. Reseat DIMM(s). Reconnect it to power.
4. Make sure that DSA and BIOS/uEFI are at the latest level.

Related links

- IBM Support website
- Latest level of DSA
- Latest level of BMC/IMM

- **201-877-003 : Standalone Memory Test Aborted**

BIOS: Sparing in Extended PCI reg. must be OFF. Go to setup and disable sparing.

Recoverable

No

Severity

Warning

Serviceable

No

Automatically notify support

No

User Response

Complete the following steps:

1. Perform the actions mentioned one at a time and try the test after each action.
2. If the problem remains, contact your technical-service representative.
3. Turn off the system and disconnect it from power. Wait for 45 seconds. Reseat DIMM(s). Reconnect it to power.
4. Make sure that DSA and BIOS/uEFI are at the latest level.

Related links

- IBM Support website
- Latest level of DSA
- Latest level of BMC/IMM

- **201-878-000 : Standalone Memory Test Aborted**

Sparing feature must be turned OFF. Go to setup and turn the sparing feature OFF.

Recoverable

No

Severity

Warning

Serviceable

No

Automatically notify support

No

User Response

Complete the following steps:

1. Perform the actions mentioned one at a time and try the test after each action.
2. If the problem remains, contact your technical-service representative.
3. Turn off the system and disconnect it from power. Wait for 45 seconds. Reseat DIMM(s). Reconnect it to power.
4. Make sure that DSA and BIOS/uEFI are at the latest level.

Related links

- IBM Support website
- Latest level of DSA
- Latest level of BMC/IMM

- **201-878-001 : Standalone Memory Test Aborted**

Sparing feature must be turned OFF. Go to setup and turn the sparing feature OFF.

Recoverable

No

Severity

Warning

Serviceable

No

Automatically notify support

No

User Response

Complete the following steps:

1. Perform the actions mentioned one at a time and try the test after each action.
2. If the problem remains, contact your technical-service representative.

3. Turn off the system and disconnect it from power. Wait for 45 seconds. Reseat DIMM(s). Reconnect it to power.
4. Make sure that DSA and BIOS/uEFI are at the latest level.

Related links

- IBM Support website
- Latest level of DSA
- Latest level of BMC/IMM

- **201-878-002 : Standalone Memory Test Aborted**

Sparing feature must be turned OFF. Go to setup and turn the sparing feature OFF.

Recoverable

No

Severity

Warning

Serviceable

No

Automatically notify support

No

User Response

Complete the following steps:

1. Perform the actions mentioned one at a time and try the test after each action.
2. If the problem remains, contact your technical-service representative.
3. Turn off the system and disconnect it from power. Wait for 45 seconds. Reseat DIMM(s). Reconnect it to power.
4. Make sure that DSA and BIOS/uEFI are at the latest level.

Related links

- IBM Support website
- Latest level of DSA
- Latest level of BMC/IMM

- **201-878-003 : Standalone Memory Test Aborted**

Sparing feature must be turned OFF. Go to setup and turn the sparing feature OFF.

Recoverable

No

Severity

Warning

Serviceable

No

Automatically notify support

No

User Response

Complete the following steps:

1. Perform the actions mentioned one at a time and try the test after each action.
2. If the problem remains, contact your technical-service representative.
3. Turn off the system and disconnect it from power. Wait for 45 seconds. Reseat DIMM(s). Reconnect it to power.
4. Make sure that DSA and BIOS/uEFI are at the latest level.

Related links

- IBM Support website
- Latest level of DSA
- Latest level of BMC/IMM

• 201-885-000 : Standalone Memory Test Aborted

Processor does not support MTRR register manipulation. Can not write to memory without cache.

Recoverable

No

Severity

Warning

Serviceable

No

Automatically notify support

No

User Response

Complete the following steps:

1. Perform the actions mentioned one at a time and try the test after each action.
2. If the problem remains, contact your technical-service representative.
3. Turn off the system and disconnect it from power. Wait for 45 seconds. Reseat DIMM(s). Reconnect it to power.
4. Make sure that DSA and BIOS/uEFI are at the latest level.

Related links

- IBM Support website
- Latest level of DSA
- Latest level of BMC/IMM

• 201-885-001 : Standalone Memory Test Aborted

Processor does not support MTRR register manipulation. Can not write to memory without cache.

Recoverable

No

Severity

Warning

Serviceable

No

Automatically notify support

No

User Response

Complete the following steps:

1. Perform the actions mentioned one at a time and try the test after each action.
2. If the problem remains, contact your technical-service representative.
3. Turn off the system and disconnect it from power. Wait for 45 seconds. Reseat DIMM(s). Reconnect it to power.
4. Make sure that DSA and BIOS/uEFI are at the latest level.

Related links

- IBM Support website
- Latest level of DSA
- Latest level of BMC/IMM

• 201-885-002 : Standalone Memory Test Aborted

Processor does not support MTRR register manipulation. Can not write to memory without cache.

Recoverable

No

Severity

Warning

Serviceable

No

Automatically notify support

No

User Response

Complete the following steps:

1. Perform the actions mentioned one at a time and try the test after each action.
2. If the problem remains, contact your technical-service representative.
3. Turn off the system and disconnect it from power. Wait for 45 seconds. Reseat DIMM(s). Reconnect it to power.
4. Make sure that DSA and BIOS/uEFI are at the latest level.

Related links

- IBM Support website
- Latest level of DSA
- Latest level of BMC/IMM

• 201-885-003 : Standalone Memory Test Aborted

Processor does not support MTRR register manipulation. Can not write to memory without cache.

Recoverable

No

Severity

Warning

Serviceable

No

Automatically notify support

No

User Response

Complete the following steps:

1. Perform the actions mentioned one at a time and try the test after each action.
2. If the problem remains, contact your technical-service representative.
3. Turn off the system and disconnect it from power. Wait for 45 seconds. Reseat DIMM(s). Reconnect it to power.
4. Make sure that DSA and BIOS/uEFI are at the latest level.

Related links

- IBM Support website
- Latest level of DSA
- Latest level of BMC/IMM

• 201-886-000 : Standalone Memory Test Aborted

Memory Upper limit is less than 16 Mbytes.

Recoverable

No

Severity

Warning

Serviceable

No

Automatically notify support

No

User Response

Complete the following steps:

1. Perform the actions mentioned one at a time and try the test after each action.
2. If the problem remains, contact your technical-service representative.
3. Turn off the system and disconnect it from power. Wait for 45 seconds. Reseat DIMM(s). Reconnect it to power.
4. Make sure that DSA and BIOS/uEFI are at the latest level.

Related links

- IBM Support website
- Latest level of DSA
- Latest level of BMC/IMM

- **201-886-001 : Standalone Memory Test Aborted**

Memory Upper limit is less than 16 Mbytes.

Recoverable

No

Severity

Warning

Serviceable

No

Automatically notify support

No

User Response

Complete the following steps:

1. Perform the actions mentioned one at a time and try the test after each action.
2. If the problem remains, contact your technical-service representative.
3. Turn off the system and disconnect it from power. Wait for 45 seconds. Reseat DIMM(s). Reconnect it to power.
4. Make sure that DSA and BIOS/uEFI are at the latest level.

Related links

- IBM Support website
- Latest level of DSA
- Latest level of BMC/IMM

- **201-886-002 : Standalone Memory Test Aborted**

Memory Upper limit is less than 16 Mbytes.

Recoverable

No

Severity

Warning

Serviceable

No

Automatically notify support

No

User Response

Complete the following steps:

1. Perform the actions mentioned one at a time and try the test after each action.
2. If the problem remains, contact your technical-service representative.
3. Turn off the system and disconnect it from power. Wait for 45 seconds. Reseat DIMM(s). Reconnect it to power.
4. Make sure that DSA and BIOS/uEFI are at the latest level.

Related links

- IBM Support website
- Latest level of DSA
- Latest level of BMC/IMM

- **201-886-003 : Standalone Memory Test Aborted**

Memory Upper limit is less than 16 Mbytes.

Recoverable

No

Severity

Warning

Serviceable

No

Automatically notify support

No

User Response

Complete the following steps:

1. Perform the actions mentioned one at a time and try the test after each action.
2. If the problem remains, contact your technical-service representative.
3. Turn off the system and disconnect it from power. Wait for 45 seconds. Reseat DIMM(s). Reconnect it to power.
4. Make sure that DSA and BIOS/uEFI are at the latest level.

Related links

- IBM Support website
- Latest level of DSA
- Latest level of BMC/IMM

- **201-899-000 : Standalone Memory Test Aborted**

Memory Diagnostics Test Aborted by user.

Recoverable

No

Severity

Warning

Serviceable

No

Automatically notify support

No

Related links

- IBM Support website
- Latest level of DSA
- Latest level of BMC/IMM

- **201-899-001 : Standalone Memory Test Aborted**

Memory Diagnostics Test Aborted by user.

Recoverable

No

Severity

Warning

Serviceable

No

Automatically notify support

No

Related links

- IBM Support website
- Latest level of DSA
- Latest level of BMC/IMM

- **201-899-002 : Standalone Memory Test Aborted**

Memory Diagnostics Test Aborted by user.

Recoverable

No

Severity

Warning

Serviceable

No

Automatically notify support

No

Related links

- IBM Support website
- Latest level of DSA
- Latest level of BMC/IMM

- **201-899-003 : Standalone Memory Test Aborted**

Memory Diagnostics Test Aborted by user.

Recoverable

No

Severity

Warning

Serviceable

No

Automatically notify support

No

Related links

- IBM Support website
- Latest level of DSA
- Latest level of BMC/IMM

- **201-901-000 : Standalone Memory Test Failed**

Memory Diagnostics Test Failed.

Recoverable

No

Severity

Error

Serviceable

Yes

Automatically notify support

No

User Response

Complete the following steps:

1. Perform the actions mentioned one at a time and try the test after each action.
2. If the problem remains, contact your technical-service representative.
3. Turn off the system and disconnect it from power. Wait for 45 seconds. Reseat DIMM(s). Reconnect it to power.
4. Make sure that DSA and BIOS/uEFI are at the latest level.
5. Replace any DIMMS(s) mentioned in error, one by one.
6. Make sure that all DIMMs are enabled in the Configuration/Setup Utility program.
7. If failure remains, refer to "Troubleshooting by symptom" in the system "Installation and Service Guide" for the next corrective action.

Related links

- IBM Support website
- Latest level of DSA
- Latest level of BMC/IMM

- **201-901-001 : Standalone Memory Test Failed**

Memory Diagnostics Test Failed.

Recoverable

No

Severity

Error

Serviceable

Yes

Automatically notify support

No

User Response

Complete the following steps:

1. Perform the actions mentioned one at a time and try the test after each action.
2. If the problem remains, contact your technical-service representative.
3. Turn off the system and disconnect it from power. Wait for 45 seconds. Reseat DIMM(s). Reconnect it to power.
4. Make sure that DSA and BIOS/uEFI are at the latest level.
5. Replace any DIMMS(s) mentioned in error, one by one.
6. Make sure that all DIMMs are enabled in the Configuration/Setup Utility program.
7. If failure remains, refer to "Troubleshooting by symptom" in the system "Installation and Service Guide" for the next corrective action.

Related links

- IBM Support website
- Latest level of DSA
- Latest level of BMC/IMM

• 201-901-002 : Standalone Memory Test Failed

Memory Diagnostics Test Failed.

Recoverable

No

Severity

Error

Serviceable

Yes

Automatically notify support

No

User Response

Complete the following steps:

1. Perform the actions mentioned one at a time and try the test after each action.
2. If the problem remains, contact your technical-service representative.
3. Turn off the system and disconnect it from power. Wait for 45 seconds. Reseat DIMM(s). Reconnect it to power.
4. Make sure that DSA and BIOS/uEFI are at the latest level.
5. Replace any DIMMS(s) mentioned in error, one by one.
6. Make sure that all DIMMs are enabled in the Configuration/Setup Utility program.
7. If failure remains, refer to "Troubleshooting by symptom" in the system "Installation and Service Guide" for the next corrective action.

Related links

- IBM Support website
- Latest level of DSA
- Latest level of BMC/IMM

- **201-901-003 : Standalone Memory Test Failed**

Memory Diagnostics Test Failed.

Recoverable

No

Severity

Error

Serviceable

Yes

Automatically notify support

No

User Response

Complete the following steps:

1. Perform the actions mentioned one at a time and try the test after each action.
2. If the problem remains, contact your technical-service representative.
3. Turn off the system and disconnect it from power. Wait for 45 seconds. Reseat DIMM(s). Reconnect it to power.
4. Make sure that DSA and BIOS/uEFI are at the latest level.
5. Replace any DIMMS(s) mentioned in error, one by one.
6. Make sure that all DIMMs are enabled in the Configuration/Setup Utility program.
7. If failure remains, refer to "Troubleshooting by symptom" in the system "Installation and Service Guide" for the next corrective action.

Related links

- IBM Support website
- Latest level of DSA
- Latest level of BMC/IMM

DSA memory stress test results

The following messages can result when you run the memory stress test.

Test results for the DSA memory stress test

The following messages can result when you run the DSA memory stress test.

- **202-000-000 : MemStr Test Passed**

Test Passed.

Recoverable

No

Severity

Event

Serviceable

No

Automatically notify support

No

Related links

- IBM Support website
- Latest level of DSA
- Latest level of BMC/IMM

- **202-801-000 : MemStr Test Aborted**

Internal program error.

Recoverable

No

Severity

Warning

Serviceable

Yes

Automatically notify support

No

User Response

Complete the following steps:

1. Turn off and restart the system.
2. Make sure that the DSA Diagnostic code is at the latest level.
3. Run the test again.
4. If the system has stopped responding, turn off and restart the system.
5. Check the system firmware level and upgrade if necessary.
6. Run the memory diagnostic to identify the specific failing DIMM.
7. If the failure remains, refer to "Troubleshooting by symptom" in the system "Installation and Service Guide" for the next corrective action.

Related links

- IBM Support website
- Latest level of DSA
- Latest level of BMC/IMM

- **202-802-000 : MemStr Test Aborted**

Memory size is insufficient to run the test. At least 1 GB is required.

Recoverable

No

Severity

Warning

Serviceable

Yes

Automatically notify support

No

Related links

- IBM Support website
- Latest level of DSA
- Latest level of BMC/IMM

- **202-803-000 : MemStr Test Aborted**

User pressed Ctrl-C.

Recoverable

No

Severity

Warning

Serviceable

Yes

Automatically notify support

No

Related links

- IBM Support website
- Latest level of DSA
- Latest level of BMC/IMM

- **202-901-000 : MemStr Test Failed**

Test Failed.

Recoverable

No

Severity

Error

Serviceable

Yes

Automatically notify support

No

User Response

Complete the following steps:

1. Execute the standard DSA memory diagnostics to validate all memory.
2. Make sure that the DSA Diagnostic code is at the latest level.
3. Turn off the system and disconnect it from power.
4. Reseat the memory cards and DIMMs.
5. Reconnect the system to power and turn the system on.

6. Run the test again.
7. Execute the standard DSA memory diagnostics to validate all memory.
8. If the failure remains, refer to "Troubleshooting by symptom" in the system "Installation and Service Guide" for the next corrective action.

Related links

- IBM Support website
- Latest level of DSA
- Latest level of BMC/IMM

- **202-902-000 : MemStr Test Failed**

Memory size is insufficient to run the test.

Recoverable

No

Severity

Error

Serviceable

Yes

Automatically notify support

No

User Response

Complete the following steps:

1. Ensure that all memory is enabled by checking the "Available System Memory" in the "Resource Utilization" section of the DSA Diagnostic Event log.
2. If necessary, access the Configuration/Setup Utility program by pressing F1 during system boot and enable all memory.
3. Make sure that the DSA Diagnostic code is at the latest level.
4. Run the test again.
5. Execute the standard DSA memory diagnostics to validate all memory.
6. If the failure remains, refer to "Troubleshooting by symptom" in the system "Installation and Service Guide" for the next corrective action.

Related links

- IBM Support website
- Latest level of DSA
- Latest level of BMC/IMM

DSA Nvidia GPU test results

The following messages can result when you run the Nvidia GPU test.

Test results for the DSA Nvidia GPU test

The following messages can result when you run the DSA Nvidia GPU test.

- **409-000-000 : NVIDIA User Diagnostic Test Passed**

NVIDIA User Diagnostic test passed.

Recoverable

No

Severity

Event

Serviceable

No

Automatically notify support

No

Related links

- IBM Support website
- Latest level of DSA
- Latest level of BMC/IMM

- **409-003-000 : Nvidia::DiagnosticServiceProvider::Bandwidth Test Passed**

Nvidia GPU Bandwidth test passed.

Recoverable

No

Severity

Event

Serviceable

No

Automatically notify support

No

Related links

- IBM Support website
- Latest level of DSA
- Latest level of BMC/IMM

- **409-004-000 : Nvidia::DiagnosticServiceProvider::Query Test Passed**

Nvidia GPU Query test passed.

Recoverable

No

Severity

Event

Serviceable

No

Automatically notify support

No

Related links

- IBM Support website
- Latest level of DSA
- Latest level of BMC/IMM

• **409-005-000 : Nvidia::DiagnosticServiceProvider::Matrix Test Passed**

Nvidia GPU Matrix test passed.

Recoverable

No

Severity

Event

Serviceable

No

Automatically notify support

No

Related links

- IBM Support website
- Latest level of DSA
- Latest level of BMC/IMM

• **409-006-000 : Nvidia::DiagnosticServiceProvider::Binomial Test Passed**

Nvidia GPU Binomial test passed.

Recoverable

No

Severity

Event

Serviceable

No

Automatically notify support

No

Related links

- IBM Support website
- Latest level of DSA
- Latest level of BMC/IMM

• **409-800-000 : NVIDIA User Diagnostic Test Aborted**

NVIDIA User Diagnostic test was canceled.

Recoverable

No

Severity

Event

Serviceable

No

Automatically notify support

No

Related links

- IBM Support website
- Latest level of DSA
- Latest level of BMC/IMM

- **409-803-000 : Nvidia::DiagnosticServiceProvider::Bandwidth Test Aborted**

Nvidia GPU Bandwidth test was canceled.

Recoverable

No

Severity

Warning

Serviceable

No

Automatically notify support

No

Related links

- IBM Support website
- Latest level of DSA
- Latest level of BMC/IMM

- **409-804-000 : Nvidia::DiagnosticServiceProvider::Query Test Aborted**

Nvidia GPU Query test was canceled.

Recoverable

No

Severity

Warning

Serviceable

No

Automatically notify support

No

Related links

- IBM Support website
- Latest level of DSA

- Latest level of BMC/IMM

- **409-805-000 : Nvidia::DiagnosticServiceProvider::Matrix Test Aborted**

Nvidia GPU Matrix test was canceled.

Recoverable

No

Severity

Warning

Serviceable

No

Automatically notify support

No

Related links

- IBM Support website
- Latest level of DSA
- Latest level of BMC/IMM

- **409-806-000 : Nvidia::DiagnosticServiceProvider::Binomial Test Aborted**

Nvidia GPU Binomial test was canceled.

Recoverable

No

Severity

Warning

Serviceable

No

Automatically notify support

No

Related links

- IBM Support website
- Latest level of DSA
- Latest level of BMC/IMM

- **409-900-000 : NVIDIA User Diagnostic Test Failed**

NVIDIA User Diagnostic Test Failed.

Recoverable

No

Severity

Event

Serviceable

Yes

Automatically notify support

No

User Response

Complete the following steps:

1. Verify that the GPU is seated in the PCIe slot correctly by reseating the GPU. Then power cycle the system.
2. Verify that the power connectors to the GPU are connected firmly. Then power cycle the system.
3. Run `nvidia-smi -q` In some cases this will report a poorly connected power cable.
4. Rerun the diagnostics, using the same GPU, on system that is known to be working. A variety of system issues can cause diagnostic failure.
5. If the problem remains, contact your IBM technical-support representative.

Related links

- IBM Support website
- Latest level of DSA
- Latest level of BMC/IMM

- **409-903-000 : Nvidia::DiagnosticServiceProvider::Bandwidth Test Failed**

Nvidia GPU Bandwidth Test Failed.

Recoverable

No

Severity

Error

Serviceable

Yes

Automatically notify support

No

User Response

Complete the following steps:

1. Verify that the GPU is seated in the PCIe slot correctly by reseating the GPU. Then power cycle the system.
2. Verify that the power connectors to the GPU are connected firmly. Then power cycle the system.
3. Run `nvidia-smi -q` In some cases this will report a poorly connected power cable.
4. Rerun the diagnostics, using the same GPU, on system that is known to be working. A variety of system issues can cause diagnostic failure.
5. If the problem remains, contact your IBM technical-support representative.

Related links

- IBM Support website
- Latest level of DSA
- Latest level of BMC/IMM

- **409-904-000 : Nvidia::DiagnosticServiceProvider::Query Test Failed**

Nvidia GPU Query Test Failed.

Recoverable

No

Severity

Error

Serviceable

Yes

Automatically notify support

No

User Response

Complete the following steps:

1. Verify that the GPU is seated in the PCIe slot correctly by reseating the GPU. Then power cycle the system.
2. Verify that the power connectors to the GPU are connected firmly. Then power cycle the system.
3. Run nvidia-smi -q In some cases this will report a poorly connected power cable.
4. Rerun the diagnostics, using the same GPU, on system that is known to be working. A variety of system issues can cause diagnostic failure.
5. If the problem remains, contact your IBM technical-support representative.

Related links

- IBM Support website
- Latest level of DSA
- Latest level of BMC/IMM

• **409-905-000 : Nvidia::DiagnosticServiceProvider::Matrix Test Failed**

Nvidia GPU Matrix Test Failed.

Recoverable

No

Severity

Error

Serviceable

Yes

Automatically notify support

No

User Response

Complete the following steps:

1. Verify that the GPU is seated in the PCIe slot correctly by reseating the GPU. Then power cycle the system.
2. Verify that the power connectors to the GPU are connected firmly. Then power cycle the system.
3. Run nvidia-smi -q In some cases this will report a poorly connected power cable.
4. Rerun the diagnostics, using the same GPU, on system that is known to be working. A variety of system issues can cause diagnostic failure.
5. If the problem remains, contact your IBM technical-support representative.

Related links

- IBM Support website
- Latest level of DSA
- Latest level of BMC/IMM

- **409-906-000 : Nvidia::DiagnosticServiceProvider::Binomial Test Failed**

Nvidia GPU Binomial Test Failed.

Recoverable

No

Severity

Error

Serviceable

Yes

Automatically notify support

No

User Response

Complete the following steps:

1. Verify that the GPU is seated in the PCIe slot correctly by reseating the GPU. Then power cycle the system.
2. Verify that the power connectors to the GPU are connected firmly. Then power cycle the system.
3. Run `nvidia-smi -q` In some cases this will report a poorly connected power cable.
4. Rerun the diagnostics, using the same GPU, on system that is known to be working. A variety of system issues can cause diagnostic failure.
5. If the problem remains, contact your IBM technical-support representative.

Related links

- IBM Support website
- Latest level of DSA
- Latest level of BMC/IMM

DSA optical drive test results

The following messages can result when you run the optical drive test.

Test results for the DSA optical drive test

The following messages can result when you run the DSA optical drive test.

- **215-000-000 : Optical Drive Test Passed**

Optical Drive Test Passed.

Recoverable

No

Severity

Event

Serviceable

No

Automatically notify support

No

Related links

- IBM Support website
- Latest level of DSA
- Latest level of BMC/IMM

• **215-801-000 : Optical Drive Test Aborted**

Optical Drive Test Aborted. Unable to communicate with driver.

Recoverable

No

Severity

Warning

Serviceable

Yes

Automatically notify support

No

User Response

Complete the following steps:

1. Make sure that the DSA Diagnostic code is at the latest level.
2. Run the test again.
3. Check the drive cabling for loose or broken connections at both ends or damage to the cable. Replace the cable if damage is present.
4. Run the test again.
5. Check system firmware level and upgrade if necessary. The installed firmware level can be found in the DSA Diagnostic Event Log within the Firmware/VPD section for this component.
6. Run the test again.

Related links

- IBM Support website
- Latest level of DSA
- Latest level of BMC/IMM

• **215-802-000 : Optical Drive Test Aborted**

Optical Drive Test Aborted. A read error was encountered.

Recoverable

No

Severity

Warning

Serviceable

Yes

Automatically notify support

No

User Response

Complete the following steps:

1. Insert a new CD or DVD into the drive and wait for 15 seconds for the media to be recognized. Rerun the test.
2. Check the drive cabling for loose or broken connections at both ends or damage to the cable. Replace the cable if damage is present.
3. Run the test again.
4. If failure remains, refer to "Troubleshooting by symptom" in the system "Installation and Service Guide" for the next corrective action.

Related links

- IBM Support website
- Latest level of DSA
- Latest level of BMC/IMM

• 215-803-000 : Optical Drive Test Failed

Optical Drive Test Failed. Disk may be in use by the operating system.

Recoverable

No

Severity

Error

Serviceable

Yes

Automatically notify support

No

User Response

Complete the following steps:

1. Wait for the system activity to cease
2. Run the test again
3. Turn off and restart the system.
4. Run the test again.

Related links

- IBM Support website
- Latest level of DSA
- Latest level of BMC/IMM

- **215-804-000 : Optical Drive Test Aborted**

Optical Drive Test Aborted. The media tray is open.

Recoverable

No

Severity

Warning

Serviceable

Yes

Automatically notify support

No

User Response

Complete the following steps:

1. Close the media tray and wait for 15 seconds for the media to be recognized. Run the test again.
2. Insert a new CD or DVD into the drive and wait for 15 seconds for the media to be recognized. Rerun the test.
3. Check the drive cabling for loose or broken connections at both ends or damage to the cable. Replace the cable if damage is present.
4. Run the test again.
5. If failure remains, refer to "Troubleshooting by symptom" in the system "Installation and Service Guide" for the next corrective action.

Related links

- IBM Support website
- Latest level of DSA
- Latest level of BMC/IMM

- **215-901-000 : Optical Drive Test Aborted**

Optical Drive Test Aborted. Drive media is not detected.

Recoverable

No

Severity

Warning

Serviceable

Yes

Automatically notify support

No

User Response

Complete the following steps:

1. Insert a new CD or DVD into the drive and wait for 15 seconds for the media to be recognized. Rerun the test.
2. Check the drive cabling for loose or broken connections at both ends or damage to the cable. Replace the cable if damage is present.
3. Run the test again.

4. If failure remains, refer to "Troubleshooting by symptom" in the system "Installation and Service Guide" for the next corrective action.

Related links

- IBM Support website
- Latest level of DSA
- Latest level of BMC/IMM

- **215-902-000 : Optical Drive Test Failed**

Optical Drive Test Failed. Read miscompare.

Recoverable

No

Severity

Error

Serviceable

Yes

Automatically notify support

No

User Response

Complete the following steps:

1. Insert a new CD or DVD into the drive and wait for 15 seconds for the media to be recognized. Rerun the test.
2. Check the drive cabling for loose or broken connections at both ends or damage to the cable. Replace the cable if damage is present.
3. Run the test again.
4. If failure remains, refer to "Troubleshooting by symptom" in the system "Installation and Service Guide" for the next corrective action.

Related links

- IBM Support website
- Latest level of DSA
- Latest level of BMC/IMM

- **215-903-000 : Optical Drive Test Aborted**

Optical Drive Test Aborted. Could not access the device.

Recoverable

No

Severity

Warning

Serviceable

Yes

Automatically notify support

No

User Response

Complete the following steps:

1. Insert a new CD or DVD into the drive and wait for 15 seconds for the media to be recognized. Rerun the test.
2. Check the drive cabling for loose or broken connections at both ends or damage to the cable. Replace the cable if damage is present.
3. Run the test again.
4. Check system firmware level and upgrade if necessary. The installed firmware level can be found in the DSA Diagnostic Event Log within the Firmware/VPD section for this component.
5. Run the test again.
6. If failure remains, refer to "Troubleshooting by symptom" in the system "Installation and Service Guide" for the next corrective action.

Related links

- IBM Support website
- Latest level of DSA
- Latest level of BMC/IMM

DSA system management test results

The following messages can result when you run the system management test.

Test results for the DSA system management test

The following messages can result when you run the DSA system management test.

- **166-000-001 : IMM I2C Test Passed**

IMM I2C Test Passed.

Recoverable

No

Severity

Event

Serviceable

No

Automatically notify support

No

Related links

- IBM Support website
- Latest level of DSA
- Latest level of BMC/IMM

- **166-801-001 : IMM I2C Test Aborted**

IMM returned incorrect response length.

Recoverable

No

Severity

Warning

Serviceable

Yes

Automatically notify support

No

User Response

Perform the actions mentioned one at a time and try the test after each action:

1. Turn off the system and disconnect it from power. Wait for 45 seconds. Reconnect it to power.
2. Make sure that DSA and BMC/IMM are at the latest level.

Related links

- IBM Support website
- Latest level of DSA
- Latest level of BMC/IMM

• **166-802-001 : IMM I2C Test Aborted**

Test cannot be completed for unknown reason.

Recoverable

No

Severity

Warning

Serviceable

Yes

Automatically notify support

No

User Response

Perform the actions mentioned one at a time and try the test after each action:

1. Turn off the system and disconnect it from power. Wait for 45 seconds. Reconnect it to power.
2. Make sure that DSA and BMC/IMM are at the latest level.

Related links

- IBM Support website
- Latest level of DSA
- Latest level of BMC/IMM

• **166-803-001 : IMM I2C Test Aborted**

Node Busy. Try later.

Recoverable

No

Severity

Warning

Serviceable

Yes

Automatically notify support

No

User Response

Perform the actions mentioned one at a time and try the test after each action:

1. Turn off the system and disconnect it from power. Wait for 45 seconds. Reconnect it to power.
2. Make sure that DSA and BMC/IMM are at the latest level.

Related links

- IBM Support website
- Latest level of DSA
- Latest level of BMC/IMM

- **166-804-001 : IMM I2C Test Aborted**

Invalid Command.

Recoverable

No

Severity

Warning

Serviceable

Yes

Automatically notify support

No

User Response

Perform the actions mentioned one at a time and try the test after each action:

1. Turn off the system and disconnect it from power. Wait for 45 seconds. Reconnect it to power.
2. Make sure that DSA and BMC/IMM are at the latest level.

Related links

- IBM Support website
- Latest level of DSA
- Latest level of BMC/IMM

- **166-805-001 : IMM I2C Test Aborted**

Invalid Command for given LUN.

Recoverable

No

Severity

Warning

Serviceable

Yes

Automatically notify support

No

User Response

Perform the actions mentioned one at a time and try the test after each action:

1. Turn off the system and disconnect it from power. Wait for 45 seconds. Reconnect it to power.
2. Make sure that DSA and BMC/IMM are at the latest level.

Related links

- IBM Support website
- Latest level of DSA
- Latest level of BMC/IMM

- **166-806-001 : IMM I2C Test Aborted**

Timeout while processing command.

Recoverable

No

Severity

Warning

Serviceable

Yes

Automatically notify support

No

User Response

Perform the actions mentioned one at a time and try the test after each action:

1. Turn off the system and disconnect it from power. Wait for 45 seconds. Reconnect it to power.
2. Make sure that DSA and BMC/IMM are at the latest level.

Related links

- IBM Support website
- Latest level of DSA
- Latest level of BMC/IMM

- **166-807-001 : IMM I2C Test Aborted**

Out of space.

Recoverable

No

Severity

Warning

Serviceable

Yes

Automatically notify support

No

User Response

Perform the actions mentioned one at a time and try the test after each action:

1. Turn off the system and disconnect it from power. Wait for 45 seconds. Reconnect it to power.
2. Make sure that DSA and BMC/IMM are at the latest level.

Related links

- IBM Support website
- Latest level of DSA
- Latest level of BMC/IMM

- **166-808-001 : IMM I2C Test Aborted**

Reservation Canceled or Invalid Reservation ID.

Recoverable

No

Severity

Warning

Serviceable

Yes

Automatically notify support

No

User Response

Perform the actions mentioned one at a time and try the test after each action:

1. Turn off the system and disconnect it from power. Wait for 45 seconds. Reconnect it to power.
2. Make sure that DSA and BMC/IMM are at the latest level.

Related links

- IBM Support website
- Latest level of DSA
- Latest level of BMC/IMM

- **166-809-001 : IMM I2C Test Aborted**

Request data truncated.

Recoverable

No

Severity

Warning

Serviceable

Yes

Automatically notify support

No

User Response

Perform the actions mentioned one at a time and try the test after each action:

1. Turn off the system and disconnect it from power. Wait for 45 seconds. Reconnect it to power.
2. Make sure that DSA and BMC/IMM are at the latest level.

Related links

- IBM Support website
- Latest level of DSA
- Latest level of BMC/IMM

- **166-810-001 : IMM I2C Test Aborted**

Request data length invalid.

Recoverable

No

Severity

Warning

Serviceable

Yes

Automatically notify support

No

User Response

Perform the actions mentioned one at a time and try the test after each action:

1. Turn off the system and disconnect it from power. Wait for 45 seconds. Reconnect it to power.
2. Make sure that DSA and BMC/IMM are at the latest level.

Related links

- IBM Support website
- Latest level of DSA
- Latest level of BMC/IMM

- **166-811-001 : IMM I2C Test Aborted**

Request data field length limit exceeded.

Recoverable

No

Severity

Warning

Serviceable

Yes

Automatically notify support

No

User Response

Perform the actions mentioned one at a time and try the test after each action:

1. Turn off the system and disconnect it from power. Wait for 45 seconds. Reconnect it to power.
2. Make sure that DSA and BMC/IMM are at the latest level.

Related links

- IBM Support website
- Latest level of DSA
- Latest level of BMC/IMM

- **166-812-001 : IMM I2C Test Aborted**

Parameter out of range.

Recoverable

No

Severity

Warning

Serviceable

Yes

Automatically notify support

No

User Response

Perform the actions mentioned one at a time and try the test after each action:

1. Turn off the system and disconnect it from power. Wait for 45 seconds. Reconnect it to power.
2. Make sure that DSA and BMC/IMM are at the latest level.

Related links

- IBM Support website
- Latest level of DSA
- Latest level of BMC/IMM

- **166-813-001 : IMM I2C Test Aborted**

Cannot return number of requested data bytes.

Recoverable

No

Severity

Warning

Serviceable

Yes

Automatically notify support

No

User Response

Perform the actions mentioned one at a time and try the test after each action:

1. Turn off the system and disconnect it from power. Wait for 45 seconds. Reconnect it to power.
2. Make sure that DSA and BMC/IMM are at the latest level.

Related links

- IBM Support website
- Latest level of DSA
- Latest level of BMC/IMM

- **166-814-001 : IMM I2C Test Aborted**

Requested Sensor, data, or record not present.

Recoverable

No

Severity

Warning

Serviceable

Yes

Automatically notify support

No

User Response

Perform the actions mentioned one at a time and try the test after each action:

1. Turn off the system and disconnect it from power. Wait for 45 seconds. Reconnect it to power.
2. Make sure that DSA and BMC/IMM are at the latest level.

Related links

- IBM Support website
- Latest level of DSA
- Latest level of BMC/IMM

- **166-815-001 : IMM I2C Test Aborted**

Invalid data field in Request.

Recoverable

No

Severity

Warning

Serviceable

Yes

Automatically notify support

No

User Response

Perform the actions mentioned one at a time and try the test after each action:

1. Turn off the system and disconnect it from power. Wait for 45 seconds. Reconnect it to power.
2. Make sure that DSA and BMC/IMM are at the latest level.

Related links

- IBM Support website
- Latest level of DSA
- Latest level of BMC/IMM

- **166-816-001 : IMM I2C Test Aborted**

Command illegal for specified sensor or record type.

Recoverable

No

Severity

Warning

Serviceable

Yes

Automatically notify support

No

User Response

Perform the actions mentioned one at a time and try the test after each action:

1. Turn off the system and disconnect it from power. Wait for 45 seconds. Reconnect it to power.
2. Make sure that DSA and BMC/IMM are at the latest level.

Related links

- IBM Support website
- Latest level of DSA
- Latest level of BMC/IMM

- **166-817-001 : IMM I2C Test Aborted**

Command response could not be provided.

Recoverable

No

Severity

Warning

Serviceable

Yes

Automatically notify support

No

User Response

Perform the actions mentioned one at a time and try the test after each action:

1. Turn off the system and disconnect it from power. Wait for 45 seconds. Reconnect it to power.
2. Make sure that DSA and BMC/IMM are at the latest level.

Related links

- IBM Support website
- Latest level of DSA
- Latest level of BMC/IMM

- **166-818-001 : IMM I2C Test Aborted**

Cannot execute duplicated request.

Recoverable

No

Severity

Warning

Serviceable

Yes

Automatically notify support

No

User Response

Perform the actions mentioned one at a time and try the test after each action:

1. Turn off the system and disconnect it from power. Wait for 45 seconds. Reconnect it to power.
2. Make sure that DSA and BMC/IMM are at the latest level.

Related links

- IBM Support website
- Latest level of DSA
- Latest level of BMC/IMM

- **166-819-001 : IMM I2C Test Aborted**

Command response could not be provided. SDR Repository in?update mode.

Recoverable

No

Severity

Warning

Serviceable

Yes

Automatically notify support

No

User Response

Perform the actions mentioned one at a time and try the test after each action:

1. Turn off the system and disconnect it from power. Wait for 45 seconds. Reconnect it to power.
2. Make sure that DSA and BMC/IMM are at the latest level.

Related links

- IBM Support website
- Latest level of DSA

- Latest level of BMC/IMM

- **166-820-001 : IMM I2C Test Aborted**

Command response could not be provided. Device in firmware update mode.

Recoverable

No

Severity

Warning

Serviceable

Yes

Automatically notify support

No

User Response

Perform the actions mentioned one at a time and try the test after each action:

1. Turn off the system and disconnect it from power. Wait for 45 seconds. Reconnect it to power.
2. Make sure that DSA and BMC/IMM are at the latest level.

Related links

- IBM Support website
- Latest level of DSA
- Latest level of BMC/IMM

- **166-821-001 : IMM I2C Test Aborted**

Command response could not be provided. BMC initialization in progress.

Recoverable

No

Severity

Warning

Serviceable

Yes

Automatically notify support

No

User Response

Perform the actions mentioned one at a time and try the test after each action:

1. Turn off the system and disconnect it from power. Wait for 45 seconds. Reconnect it to power.
2. Make sure that DSA and BMC/IMM are at the latest level.

Related links

- IBM Support website
- Latest level of DSA
- Latest level of BMC/IMM

- **166-822-001 : IMM I2C Test Aborted**

Destination unavailable.

Recoverable

No

Severity

Warning

Serviceable

Yes

Automatically notify support

No

User Response

Perform the actions mentioned one at a time and try the test after each action:

1. Turn off the system and disconnect it from power. Wait for 45 seconds. Reconnect it to power.
2. Make sure that DSA and BMC/IMM are at the latest level.

Related links

- IBM Support website
- Latest level of DSA
- Latest level of BMC/IMM

- **166-823-001 : IMM I2C Test Aborted**

Cannot execute command. Insufficient privilege level.

Recoverable

No

Severity

Warning

Serviceable

Yes

Automatically notify support

No

User Response

Perform the actions mentioned one at a time and try the test after each action:

1. Turn off the system and disconnect it from power. Wait for 45 seconds. Reconnect it to power.
2. Make sure that DSA and BMC/IMM are at the latest level.

Related links

- IBM Support website
- Latest level of DSA
- Latest level of BMC/IMM

- **166-824-001 : IMM I2C Test Aborted**

Cannot execute command.

Recoverable

No

Severity

Warning

Serviceable

Yes

Automatically notify support

No

User Response

Perform the actions mentioned one at a time and try the test after each action:

1. Turn off the system and disconnect it from power. Wait for 45 seconds. Reconnect it to power.
2. Make sure that DSA and BMC/IMM are at the latest level.

Related links

- IBM Support website
- Latest level of DSA
- Latest level of BMC/IMM

• **166-901-001 : IMM I2C Test Failed**

IMM Indicates failure in RTMM bus (BUS 0).

Recoverable

No

Severity

Error

Serviceable

Yes

Automatically notify support

No

User Response

Perform the actions mentioned one at a time and try the test after each action:

1. Turn off the system and disconnect it from power. Wait for 45 seconds. Reconnect it to power.
2. Make sure that DSA and BMC/IMM are at the latest level.
3. Run the test again.
4. If failure remains, refer to "Troubleshooting by symptom" in the system "Installation and Service Guide" for the next corrective action.

Related links

- IBM Support website
- Latest level of DSA
- Latest level of BMC/IMM

- **166-902-001 : IMM I2C Test Failed**

IMM Indicates failure in TPM bus (BUS 1).

Recoverable

No

Severity

Error

Serviceable

Yes

Automatically notify support

No

User Response

Perform the actions mentioned one at a time and try the test after each action:

1. Turn off the system and disconnect it from power. Wait for 45 seconds. Reconnect it to power.
2. Make sure that DSA and BMC/IMM are at the latest level.
3. Run the test again.
4. If failure remains, refer to "Troubleshooting by symptom" in the system "Installation and Service Guide" for the next corrective action.

Related links

- IBM Support website
- Latest level of DSA
- Latest level of BMC/IMM

- **166-903-001 : IMM I2C Test Failed**

IMM Indicates failure in Clock bus (BUS 2).

Recoverable

No

Severity

Error

Serviceable

Yes

Automatically notify support

No

User Response

Perform the actions mentioned one at a time and try the test after each action:

1. Turn off the system and disconnect it from power. Wait for 45 seconds. Reconnect it to power.
2. Make sure that DSA and BMC/IMM are at the latest level.
3. Run the test again.
4. If failure remains, refer to "Troubleshooting by symptom" in the system "Installation and Service Guide" for the next corrective action.

Related links

- IBM Support website
- Latest level of DSA
- Latest level of BMC/IMM

- **166-904-001 : IMM I2C Test Failed**

IMM Indicates failure in LED bus (BUS 3).

Recoverable

No

Severity

Error

Serviceable

Yes

Automatically notify support

No

User Response

Perform the actions mentioned one at a time and try the test after each action:

1. Turn off the system and disconnect it from power. Wait for 45 seconds. Reconnect it to power.
2. Make sure that DSA and BMC/IMM are at the latest level.
3. Run the test again.
4. If failure remains, refer to "Troubleshooting by symptom" in the system "Installation and Service Guide" for the next corrective action.

Related links

- IBM Support website
- Latest level of DSA
- Latest level of BMC/IMM

- **166-905-001 : IMM I2C Test Failed**

IMM Indicates failure in Power Supply bus (BUS 4).

Recoverable

No

Severity

Error

Serviceable

Yes

Automatically notify support

No

User Response

Perform the actions mentioned one at a time and try the test after each action:

1. Turn off the system and disconnect it from power. Wait for 45 seconds. Reconnect it to power.
2. Make sure that DSA and BMC/IMM are at the latest level.
3. Run the test again.

4. If failure remains, refer to "Troubleshooting by symptom" in the system "Installation and Service Guide" for the next corrective action.

Related links

- IBM Support website
- Latest level of DSA
- Latest level of BMC/IMM

- **166-906-001 : IMM I2C Test Failed**

IMM Indicates failure in PCIe bus (BUS 5).

Recoverable

No

Severity

Error

Serviceable

Yes

Automatically notify support

No

User Response

Perform the actions mentioned one at a time and try the test after each action:

1. Turn off the system and disconnect it from power. Wait for 45 seconds. Reconnect it to power.
2. Make sure that DSA and BMC/IMM are at the latest level.
3. Run the test again.
4. If failure remains, refer to "Troubleshooting by symptom" in the system "Installation and Service Guide" for the next corrective action.

Related links

- IBM Support website
- Latest level of DSA
- Latest level of BMC/IMM

- **166-907-001 : IMM I2C Test Failed**

IMM Indicates failure in Optional Mezz Card bus (BUS 6).

Recoverable

No

Severity

Error

Serviceable

Yes

Automatically notify support

No

User Response

Perform the actions mentioned one at a time and try the test after each action:

1. Turn off the system and disconnect it from power. Wait for 45 seconds. Reconnect it to power.
2. Make sure that DSA and BMC/IMM are at the latest level.
3. Run the test again.
4. If failure remains, refer to "Troubleshooting by symptom" in the system "Installation and Service Guide" for the next corrective action.

Related links

- IBM Support website
- Latest level of DSA
- Latest level of BMC/IMM

- **166-908-001 : IMM I2C Test Failed**

IMM Indicates failure in the DASD bus (BUS 7).

Recoverable

No

Severity

Error

Serviceable

Yes

Automatically notify support

No

User Response

Perform the actions mentioned one at a time and try the test after each action:

1. Turn off the system and disconnect it from power. Wait for 45 seconds. Reconnect it to power.
2. Make sure that DSA and BMC/IMM are at the latest level.
3. Run the test again.
4. If failure remains, refer to "Troubleshooting by symptom" in the system "Installation and Service Guide" for the next corrective action.

Related links

- IBM Support website
- Latest level of DSA
- Latest level of BMC/IMM

DSA tape drive test results

The following messages can result when you run the tape drive test.

Test results for the DSA tape drive test

The following messages can result when you run the DSA tape drive test.

- **264-000-000 : Tape Test Passed**

Tape Test Passed.

Recoverable

No

Severity

Event

Serviceable

No

Automatically notify support

No

Related links

- IBM Support website
- Latest level of DSA
- Latest level of BMC/IMM

- **264-901-000 : Tape Test Failed**

An error was found in the tape alert log.

Recoverable

No

Severity

Error

Serviceable

Yes

Automatically notify support

No

User Response

Complete the following steps:

1. Clean the tape drive using the appropriate cleaning media and install new media.
2. Run the test again.
3. Clear the error log.
4. Run the test again.
5. Make sure that the drive firmware is at the latest level.
6. Rerun the test after upgrading to the latest firmware level.
7. If the failure remains, refer to "Troubleshooting by symptom" in the system "Installation and Service Guide" for the next corrective action.

Related links

- IBM Support website
- Latest level of DSA
- Latest level of BMC/IMM

- **264-902-000 : Tape Test Failed**

Tape Test Failed. Media is not detected.

Recoverable

No

Severity

Error

Serviceable

Yes

Automatically notify support

No

User Response

Complete the following steps:

1. Clean the tape drive using the appropriate cleaning media and install new media.
2. Run the test again.
3. Make sure that the drive firmware is at the latest level.
4. Rerun the test after upgrading to the latest firmware level.
5. If the failure remains, refer to "Troubleshooting by symptom" in the system "Installation and Service Guide" for the next corrective action.

Related links

- IBM Support website
- Latest level of DSA
- Latest level of BMC/IMM

- **264-903-000 : Tape Test Failed**

Tape Test Failed. Media is not detected.

Recoverable

No

Severity

Error

Serviceable

Yes

Automatically notify support

No

User Response

Complete the following steps:

1. Clean the tape drive using the appropriate cleaning media and install new media.
2. Run the test again.
3. Make sure that the drive firmware is at the latest level.
4. Rerun the test after upgrading to the latest firmware level.
5. If the failure remains, refer to "Troubleshooting by symptom" in the system "Installation and Service Guide" for the next corrective action.

Related links

- IBM Support website
- Latest level of DSA
- Latest level of BMC/IMM

- **264-904-000 : Tape Test Failed**

Tape Test Failed. Drive hardware error.

Recoverable

No

Severity

Error

Serviceable

Yes

Automatically notify support

No

User Response

Complete the following steps:

1. Check the tape drive cabling for loose or broken connections or damage to the cable. Replace the cable if damage is present.
2. Clean the tape drive using the appropriate cleaning media and install new media.
3. Run the test again.
4. Make sure that the drive firmware is at the latest level.
5. Rerun the test after upgrading to the latest firmware level.
6. If the failure remains, refer to "Troubleshooting by symptom" in the system "Installation and Service Guide" for the next corrective action.

Related links

- IBM Support website
- Latest level of DSA
- Latest level of BMC/IMM

- **264-905-000 : Tape Test Failed**

Tape Test Failed. Software error: invalid request.

Recoverable

No

Severity

Error

Serviceable

Yes

Automatically notify support

No

User Response

Complete the following steps:

1. If the system has stopped responding, turn off and restart the system.
2. Check the system firmware level and upgrade if necessary. The installed firmware level can be found in the DSA Diagnostic Event Log within the Firmware/VPD section for this component.
3. Run the test again.
4. If the system has stopped responding, turn off and restart the system.
5. Make sure that the drive firmware is at the latest level.
6. Run the test again.
7. If the failure remains, refer to "Troubleshooting by symptom" in the system "Installation and Service Guide" for the next corrective action.

Related links

- IBM Support website
- Latest level of DSA
- Latest level of BMC/IMM

- **264-906-000 : Tape Test Failed**

Tape Test Failed. Unrecognized error.

Recoverable

No

Severity

Error

Serviceable

Yes

Automatically notify support

No

User Response

Complete the following steps:

1. Clean the tape drive using the appropriate cleaning media and install new media.
2. Run the test again.
3. Make sure that the drive firmware is at the latest level.
4. Rerun the test after upgrading to the latest firmware level.
5. Make sure that the DSA Diagnostic code is at the latest level.
6. Run the test again.
7. Check the system firmware level and upgrade if necessary.
8. Run the test again.
9. If the failure remains, refer to "Troubleshooting by symptom" in the system "Installation and Service Guide" for the next corrective action.

Related links

- IBM Support website
- Latest level of DSA
- Latest level of BMC/IMM

- **264-907-000 : Tape Test Failed**

An error was found in the block address somewhere.

Recoverable

No

Severity

Error

Serviceable

Yes

Automatically notify support

No

User Response

Complete the following steps:

1. Clean the tape drive using the appropriate cleaning media and install new media.

Related links

- IBM Support website
- Latest level of DSA
- Latest level of BMC/IMM

- **264-908-000 : Tape Test Failed**

An error was found in getting tape capacity.

Recoverable

No

Severity

Error

Serviceable

Yes

Automatically notify support

No

User Response

Complete the following steps:

1. Make sure that medium is present.
2. Clean the tape drive using the appropriate cleaning media and install new media.

Related links

- IBM Support website
- Latest level of DSA
- Latest level of BMC/IMM

Appendix D. Getting help and technical assistance

If you need help, service, or technical assistance or just want more information about Lenovo products, you will find a wide variety of sources available from Lenovo to assist you.

Use this information to obtain additional information about Lenovo and Lenovo products, and determine what to do if you experience a problem with your Lenovo system or optional device.

Note: This section includes references to IBM web sites and information about obtaining service. IBM is Lenovo's preferred service provider for the System x, Flex System, and NeXtScale System products.

Before you call

Before you call, make sure that you have taken these steps to try to solve the problem yourself.

If you believe that you require warranty service for your Lenovo product, the service technicians will be able to assist you more efficiently if you prepare before you call.

- Check all cables to make sure that they are connected.
- Check the power switches to make sure that the system and any optional devices are turned on.
- Check for updated software, firmware, and operating-system device drivers for your Lenovo product. The Lenovo Warranty terms and conditions state that you, the owner of the Lenovo product, are responsible for maintaining and updating all software and firmware for the product (unless it is covered by an additional maintenance contract). Your service technician will request that you upgrade your software and firmware if the problem has a documented solution within a software upgrade.
- If you have installed new hardware or software in your environment, check <http://www.lenovo.com/serverproven/> to make sure that the hardware and software is supported by your product.
- Go to <http://www.lenovo.com/support> to check for information to help you solve the problem.
- Gather the following information to provide to the service technician. This data will help the service technician quickly provide a solution to your problem and ensure that you receive the level of service for which you might have contracted.
 - Hardware and Software Maintenance agreement contract numbers, if applicable
 - Machine type number (Lenovo 4-digit machine identifier)
 - Model number
 - Serial number
 - Current system UEFI and firmware levels
 - Other pertinent information such as error messages and logs
- Go to http://www.ibm.com/support/entry/portal/Open_service_request to submit an Electronic Service Request. Submitting an Electronic Service Request will start the process of determining a solution to your problem by making the pertinent information available to the service technicians. The IBM service technicians can start working on your solution as soon as you have completed and submitted an Electronic Service Request.

You can solve many problems without outside assistance by following the troubleshooting procedures that Lenovo provides in the online help or in the Lenovo product documentation. The Lenovo product documentation also describes the diagnostic tests that you can perform. The documentation for most systems, operating systems, and programs contains troubleshooting procedures and explanations of error messages and error codes. If you suspect a software problem, see the documentation for the operating system or program.

Using the documentation

Information about your Lenovo system and preinstalled software, if any, or optional device is available in the product documentation. That documentation can include printed documents, online documents, readme files, and help files.

See the troubleshooting information in your system documentation for instructions for using the diagnostic programs. The troubleshooting information or the diagnostic programs might tell you that you need additional or updated device drivers or other software. Lenovo maintains pages on the World Wide Web where you can get the latest technical information and download device drivers and updates. To access these pages, go to <http://www.lenovo.com/support>.

Getting help and information from the World Wide Web

Up-to-date information about Lenovo products and support is available on the World Wide Web.

On the World Wide Web, up-to-date information about Lenovo systems, optional devices, services, and support is available at <http://www.lenovo.com/support>. The most current version of the product documentation is available in the following product-specific Information Centers:

- **Flex System products:**
<http://pic.dhe.ibm.com/infocenter/flexsys/information/index.jsp>
- **System x products:**
<http://shop.lenovo.com/us/en/systems/>
- **NeXtScale System products:**
<http://pic.dhe.ibm.com/infocenter/nxtscale/documentation/index.jsp>

How to send DSA data

You can use the Enhanced Customer Data Repository to send diagnostic data to IBM.

Before you send diagnostic data to IBM, read the terms of use at <http://www.ibm.com/de/support/ecurep/terms.html>.

You can use any of the following methods to send diagnostic data:

- **Standard upload:**
http://www.ibm.com/de/support/ecurep/send_http.html
- **Standard upload with the system serial number:**
http://www.ecurep.ibm.com/app/upload_hw
- **Secure upload:**
http://www.ibm.com/de/support/ecurep/send_http.html#secure
- **Secure upload with the system serial number:**
https://www.ecurep.ibm.com/app/upload_hw

Creating a personalized support web page

You can create a personalized support web page by identifying Lenovo products that are of interest to you.

To create a personalized support web page, go to <http://www.ibm.com/support/mynotifications>. From this personalized page, you can subscribe to weekly email notifications about new technical documents, search for information and downloads, and access various administrative services.

Software service and support

Through IBM Support Line, you can get telephone assistance, for a fee, with usage, configuration, and software problems with your Lenovo products.

For more information about Support Line and other IBM services, see <http://www.ibm.com/services> or see <http://www.ibm.com/planetwide> for support telephone numbers. In the U.S. and Canada, call 1-800-IBM-SERV (1-800-426-7378).

Hardware service and support

IBM is Lenovo's preferred service provider for the System x, Flex System and NeXtScale System products.

You can receive hardware service through your Lenovo reseller or from IBM. To locate a reseller authorized by Lenovo to provide warranty service, go to <http://www.ibm.com/partnerworld> and click **Business Partner Locator**. For IBM support telephone numbers, see <http://www.ibm.com/planetwide>. In the U.S. and Canada, call 1-800-IBM-SERV (1-800-426-7378).

In the U.S. and Canada, hardware service and support is available 24 hours a day, 7 days a week. In the U.K., these services are available Monday through Friday, from 9 a.m. to 6 p.m.

Taiwan product service

Use this information to contact IBM Taiwan product service.

台灣 IBM 產品服務聯絡方式：
台灣國際商業機器股份有限公司
台北市松仁路 7 號 3 樓
電話：0800-016-888

IBM Taiwan product service contact information:

IBM Taiwan Corporation
3F, No 7, Song Ren Rd.
Taipei, Taiwan
Telephone: 0800-016-888

Appendix E. Notices

Lenovo may not offer the products, services, or features discussed in this document in all countries. Consult your local Lenovo representative for information on the products and services currently available in your area.

Any reference to a Lenovo product, program, or service is not intended to state or imply that only that Lenovo product, program, or service may be used. Any functionally equivalent product, program, or service that does not infringe any Lenovo intellectual property right may be used instead. However, it is the user's responsibility to evaluate and verify the operation of any other product, program, or service.

Lenovo may have patents or pending patent applications covering subject matter described in this document. The furnishing of this document does not give you any license to these patents. You can send license inquiries, in writing, to:

*Lenovo (United States), Inc.
1009 Think Place - Building One
Morrisville, NC 27560
U.S.A.
Attention: Lenovo Director of Licensing*

LENOVO PROVIDES THIS PUBLICATION "AS IS" WITHOUT WARRANTY OF ANY KIND, EITHER EXPRESS OR IMPLIED, INCLUDING, BUT NOT LIMITED TO, THE IMPLIED WARRANTIES OF NON-INFRINGEMENT, MERCHANTABILITY OR FITNESS FOR A PARTICULAR PURPOSE. Some jurisdictions do not allow disclaimer of express or implied warranties in certain transactions, therefore, this statement may not apply to you.

This information could include technical inaccuracies or typographical errors. Changes are periodically made to the information herein; these changes will be incorporated in new editions of the publication. Lenovo may make improvements and/or changes in the product(s) and/or the program(s) described in this publication at any time without notice.

The products described in this document are not intended for use in implantation or other life support applications where malfunction may result in injury or death to persons. The information contained in this document does not affect or change Lenovo product specifications or warranties. Nothing in this document shall operate as an express or implied license or indemnity under the intellectual property rights of Lenovo or third parties. All information contained in this document was obtained in specific environments and is presented as an illustration. The result obtained in other operating environments may vary.

Lenovo may use or distribute any of the information you supply in any way it believes appropriate without incurring any obligation to you.

Any references in this publication to non-Lenovo Web sites are provided for convenience only and do not in any manner serve as an endorsement of those Web sites. The materials at those Web sites are not part of the materials for this Lenovo product, and use of those Web sites is at your own risk.

Any performance data contained herein was determined in a controlled environment. Therefore, the result obtained in other operating environments may vary significantly. Some measurements may have been made on development-level systems and there is no guarantee that these measurements will be the same on generally available systems. Furthermore, some measurements may have been estimated through extrapolation. Actual results may vary. Users of this document should verify the applicable data for their specific environment.

Trademarks

Lenovo, the Lenovo logo, Flex System, System x, NeXtScale System, and x Architecture are trademarks of Lenovo in the United States, other countries, or both.

Lenovo and the Lenovo logo are trademarks of Lenovo in the United States, other countries, or both. Other company, product, or service names may be trademarks or service marks of others.

Intel, Intel Celeron, Intel Core, Intel Pentium, and Intel Xeon are trademarks of Intel Corporation in the United States, other countries, or both.

Internet Explorer, Microsoft, and Windows are trademarks of the Microsoft group of companies.

Linux is a registered trademark of Linus Torvalds.

Red Hat and Red Hat Enterprise Linux are registered trademarks of Red Hat, Inc. in the U.S. and other countries.

Other company, product, or service names may be trademarks or service marks of others.

Important notes

Processor speed indicates the internal clock speed of the microprocessor; other factors also affect application performance.

CD or DVD drive speed is the variable read rate. Actual speeds vary and are often less than the possible maximum.

When referring to processor storage, real and virtual storage, or channel volume, KB stands for 1 024 bytes, MB stands for 1 048 576 bytes, and GB stands for 1 073 741 824 bytes.

When referring to hard disk drive capacity or communications volume, MB stands for 1 000 000 bytes, and GB stands for 1 000 000 000 bytes. Total user-accessible capacity can vary depending on operating environments.

Maximum internal hard disk drive capacities assume the replacement of any standard hard disk drives and population of all hard-disk-drive bays with the largest currently supported drives that are available from Lenovo.

Maximum memory might require replacement of the standard memory with an optional memory module.

Each solid-state memory cell has an intrinsic, finite number of write cycles that the cell can incur. Therefore, a solid-state device has a maximum number of write cycles that it can be subjected to, expressed as total bytes written (TBW). A device that has exceeded this limit might fail to respond to system-generated commands or might be incapable of being written to. Lenovo is not responsible for replacement of a device that has exceeded its maximum guaranteed number of program/erase cycles, as documented in the Official Published Specifications for the device.

Lenovo makes no representations or warranties with respect to non-Lenovo products. Support (if any) for the non-Lenovo products is provided by the third party, not Lenovo.

Some software might differ from its retail version (if available) and might not include user manuals or all program functionality.

Recycling information

Lenovo encourages owners of information technology (IT) equipment to responsibly recycle their equipment when it is no longer needed. Lenovo offers a variety of programs and services to assist equipment owners in recycling their IT products. For information on recycling Lenovo products, go to: <http://www.lenovo.com/recycling>.

Particulate contamination

Attention: Airborne particulates (including metal flakes or particles) and reactive gases acting alone or in combination with other environmental factors such as humidity or temperature might pose a risk to the device that is described in this document.

Risks that are posed by the presence of excessive particulate levels or concentrations of harmful gases include damage that might cause the device to malfunction or cease functioning altogether. This specification sets forth limits for particulates and gases that are intended to avoid such damage. The limits must not be viewed or used as definitive limits, because numerous other factors, such as temperature or moisture content of the air, can influence the impact of particulates or environmental corrosives and gaseous contaminant transfer. In the absence of specific limits that are set forth in this document, you must implement practices that maintain particulate and gas levels that are consistent with the protection of human health and safety. If Lenovo determines that the levels of particulates or gases in your environment have caused damage to the device, Lenovo may condition provision of repair or replacement of devices or parts on implementation of appropriate remedial measures to mitigate such environmental contamination. Implementation of such remedial measures is a customer responsibility.

Table 30. Limits for particulates and gases

Contaminant	Limits
Particulate	<ul style="list-style-type: none">• The room air must be continuously filtered with 40% atmospheric dust spot efficiency (MERV 9) according to ASHRAE Standard 52.2¹.• Air that enters a data center must be filtered to 99.97% efficiency or greater, using high-efficiency particulate air (HEPA) filters that meet MIL-STD-282.• The deliquescent relative humidity of the particulate contamination must be more than 60%².• The room must be free of conductive contamination such as zinc whiskers.
Gaseous	<ul style="list-style-type: none">• Copper: Class G1 as per ANSI/ISA 71.04-1985³• Silver: Corrosion rate of less than 300 Å in 30 days
<p>¹ ASHRAE 52.2-2008 - <i>Method of Testing General Ventilation Air-Cleaning Devices for Removal Efficiency by Particle Size</i>. Atlanta: American Society of Heating, Refrigerating and Air-Conditioning Engineers, Inc.</p> <p>² The deliquescent relative humidity of particulate contamination is the relative humidity at which the dust absorbs enough water to become wet and promote ionic conduction.</p> <p>³ ANSI/ISA-71.04-1985. <i>Environmental conditions for process measurement and control systems: Airborne contaminants</i>. Instrument Society of America, Research Triangle Park, North Carolina, U.S.A.</p>	

Telecommunication regulatory statement

This product may not be certified in your country for connection by any means whatsoever to interfaces of public telecommunications networks. Further certification may be required by law prior to making any such connection. Contact a Lenovo representative or reseller for any questions.

Electronic emission notices

When you attach a monitor to the equipment, you must use the designated monitor cable and any interference suppression devices that are supplied with the monitor.

Federal Communications Commission (FCC) statement

Note: This equipment has been tested and found to comply with the limits for a Class A digital device, pursuant to Part 15 of the FCC Rules. These limits are designed to provide reasonable protection against harmful interference when the equipment is operated in a commercial environment. This equipment generates, uses, and can radiate radio frequency energy and, if not installed and used in accordance with the instruction manual, may cause harmful interference to radio communications. Operation of this equipment in a residential area is likely to cause harmful interference, in which case the user will be required to correct the interference at his own expense.

Properly shielded and grounded cables and connectors must be used in order to meet FCC emission limits. Lenovo is not responsible for any radio or television interference caused by using other than recommended cables and connectors or by unauthorized changes or modifications to this equipment. Unauthorized changes or modifications could void the user's authority to operate the equipment.

This device complies with Part 15 of the FCC Rules. Operation is subject to the following two conditions: (1) this device may not cause harmful interference, and (2) this device must accept any interference received, including interference that might cause undesired operation.

Industry Canada Class A emission compliance statement

This Class A digital apparatus complies with Canadian ICES-003.

Avis de conformité à la réglementation d'Industrie Canada

Cet appareil numérique de la classe A est conforme à la norme NMB-003 du Canada.

Australia and New Zealand Class A statement

Attention: This is a Class A product. In a domestic environment this product may cause radio interference in which case the user may be required to take adequate measures.

European Union EMC Directive conformance statement

This product is in conformity with the protection requirements of EU Council Directive 2014/30/EU on the approximation of the laws of the Member States relating to electromagnetic compatibility. Lenovo cannot accept responsibility for any failure to satisfy the protection requirements resulting from a non-recommended modification of the product, including the installation of option cards from other manufacturers.

This product has been tested and found to comply with the limits for Class A equipment according to European Standards harmonized in the Directives in compliance. The limits for Class A equipment were derived for commercial and industrial environments to provide reasonable protection against interference with licensed communication equipment.

Lenovo, Einsteinova 21, 851 01 Bratislava, Slovakia



Warning: This is a Class A product. In a domestic environment this product may cause radio interference in which case the user may be required to take adequate measures.

Germany Class A statement

Deutschsprachiger EU Hinweis: Hinweis für Geräte der Klasse A EU-Richtlinie zur Elektromagnetischen Verträglichkeit

Deutschsprachiger EU Hinweis: Hinweis für Geräte der Klasse A EU-Richtlinie zur Elektromagnetischen Verträglichkeit Dieses Produkt entspricht den Schutzanforderungen der EU-Richtlinie 2014/30/EU (früher 2004/108/EC) zur Angleichung der Rechtsvorschriften über die elektromagnetische Verträglichkeit in den EU-Mitgliedsstaaten und hält die Grenzwerte der Klasse A der Norm gemäß Richtlinie.

Um dieses sicherzustellen, sind die Geräte wie in den Handbüchern beschrieben zu installieren und zu betreiben. Des Weiteren dürfen auch nur von der Lenovo empfohlene Kabel angeschlossen werden. Lenovo übernimmt keine Verantwortung für die Einhaltung der Schutzanforderungen, wenn das Produkt ohne Zustimmung der Lenovo verändert bzw. wenn Erweiterungskomponenten von Fremdherstellern ohne Empfehlung der Lenovo gesteckt/eingebaut werden.

Deutschland:

Einhaltung des Gesetzes über die elektromagnetische Verträglichkeit von Betriebsmitteln Dieses Produkt entspricht dem „Gesetz über die elektromagnetische Verträglichkeit von Betriebsmitteln“ EMVG (früher „Gesetz über die elektromagnetische Verträglichkeit von Geräten“). Dies ist die Umsetzung der EU-Richtlinie 2014/30/EU (früher 2004/108/EC) in der Bundesrepublik Deutschland.

Zulassungsbescheinigung laut dem Deutschen Gesetz über die elektromagnetische Verträglichkeit von Betriebsmitteln, EMVG vom 20. Juli 2007 (früher Gesetz über die elektromagnetische Verträglichkeit von Geräten), bzw. der EMV EU Richtlinie 2014/30/EU (früher 2004/108/EC), für Geräte der Klasse A.

Dieses Gerät ist berechtigt, in Übereinstimmung mit dem Deutschen EMVG das EG-Konformitätszeichen - CE - zu führen. Verantwortlich für die Konformitätserklärung nach Paragraph 5 des EMVG ist die Lenovo (Deutschland) GmbH, Meitnerstr. 9, D-70563 Stuttgart.

Informationen in Hinsicht EMVG Paragraph 4 Abs. (1) 4: **Das Gerät erfüllt die Schutzanforderungen nach EN 55024 und EN 55022 Klasse A.**

Nach der EN 55022: „Dies ist eine Einrichtung der Klasse A. Diese Einrichtung kann im Wohnbereich Funkstörungen verursachen; in diesem Fall kann vom Betreiber verlangt werden, angemessene Maßnahmen durchzuführen und dafür aufzukommen.“

Nach dem EMVG: „Geräte dürfen an Orten, für die sie nicht ausreichend entstört sind, nur mit besonderer Genehmigung des Bundesministers für Post und Telekommunikation oder des Bundesamtes für Post und Telekommunikation betrieben werden. Die Genehmigung wird erteilt, wenn keine elektromagnetischen Störungen zu erwarten sind.“ (Auszug aus dem EMVG, Paragraph 3, Abs. 4). Dieses Genehmigungsverfahren ist nach Paragraph 9 EMVG in Verbindung mit der entsprechenden Kostenverordnung (Amtsblatt 14/93) kostenpflichtig.

Anmerkung: Um die Einhaltung des EMVG sicherzustellen sind die Geräte, wie in den Handbüchern angegeben, zu installieren und zu betreiben.

Japan VCCI Class A statement

この装置は、クラス A 情報技術装置です。この装置を家庭環境で使用すると電波妨害を引き起こすことがあります。この場合には使用者が適切な対策を講ずるよう要求されることがあります。

VCCI-A

This is a Class A product based on the standard of the Voluntary Control Council for Interference (VCCI). If this equipment is used in a domestic environment, radio interference may occur, in which case the user may be required to take corrective actions.

Japanese statement for ac power consumption for JEITA harmonics guideline

定格入力電力表示

(社) 電子情報技術参照委員会 家電・汎用品高調波抑制対策ガイドライン 実行計画書に基づく定格入力電力値: W
--

お手持ちのユニットの定格入力電力値 (W) はユニットの電源装置に貼付されている電源仕様ラベルをご参照下さい

Japanese statement of compliance for products less than or equal to 20 A per phase for JEITA harmonics guideline

日本の定格電流が 20A/相 以下の機器に対する高調波電流規制
高調波電流規格 JIS C 61000-3-2 適合品

Korea Communications Commission (KCC) statement

이 기기는 업무용(A급)으로 전자파적합기기로서 판매자 또는 사용자는 이 점을 주의하시기 바라며, 가정외의 지역에서 사용하는 것을 목적으로 합니다.

This is electromagnetic wave compatibility equipment for business (Type A). Sellers and users need to pay attention to it. This is for any areas other than home.

Russia Electromagnetic Interference (EMI) Class A statement

ВНИМАНИЕ! Настоящее изделие относится к классу А. В жилых помещениях оно может создавать радиопомехи, для снижения которых необходимы дополнительные меры

People's Republic of China Class A electronic emission statement

声 明

此为 A 级产品。在生活环境中，该产品可能会造成无线电干扰。在这种情况下，可能需要用户对其干扰采取切实可行的措施。

Taiwan Class A compliance statement

警告使用者：
這是甲類的資訊產品，在居住的環境中使用時，可能會造成射頻干擾，在這種情況下，使用者會被要求採取某些適當的對策。

Taiwan BSMI RoHS declaration

Taiwan BSMI RoHS declaration

單元 Unit	限用物質及其化學符號 Restricted substances and its chemical symbols					
	鉛Lead (Pb)	汞Mercury (Hg)	鎘Cadmium (Cd)	六價鉻 Hexavalent chromium (Cr ⁺⁶)	多溴聯苯 Polybrominated biphenyls (PBB)	多溴二苯醚 Polybrominated diphenyl ethers (PBDE)
機架	○	○	○	○	○	○
外部蓋板	○	○	○	○	○	○
機械組套件	○	○	○	○	○	○
空氣傳動設備	-	○	○	○	○	○
冷卻組套件	-	○	○	○	○	○
內存模塊	-	○	○	○	○	○
處理器模塊	-	○	○	○	○	○
鍵盤	-	○	○	○	○	○
調製解調器	-	○	○	○	○	○
監視器	-	○	○	○	○	○
滑鼠	-	○	○	○	○	○
電纜組套件	-	○	○	○	○	○
電源	-	○	○	○	○	○
儲備設備	-	○	○	○	○	○
電池匣組套件	-	○	○	○	○	○
電池	-	○	○	○	○	○
有mech的電路卡	-	○	○	○	○	○
無mech的電路卡	-	○	○	○	○	○
激光器	-	○	○	○	○	○
<p>備考1. “超出0.1 wt%” 及 “超出0.01 wt%” 係指限用物質之百分比含量超出百分比含量基準值。 Note1: “exceeding 0.1wt%” and “exceeding 0.01 wt%” indicate that the percentage content of the restricted substance exceeds the reference percentage value of presence condition.</p> <p>備考2. “○” 係指該項限用物質之百分比含量未超出百分比含量基準值。 Note2: “○” indicates that the percentage content of the restricted substance does not exceed the percentage of reference value of presence.</p> <p>備考3. “-” 係指該項限用物質為排除項目。 Note3: The “-” indicates that the restricted substance corresponds to the exemption.</p>						

Index

2.5-inch hot-swap hard-disk-drive backplane, install 137
2.5-inch hot-swap hard-disk-drive backplane, remove 136
2.5-inch simple-swap hard-disk-drive backplate
assembly, install 139
2.5-inch simple-swap hard-disk-drive backplate
assembly, remove 138
240 VA power distribution board cover
remove 151
3.5-inch hot-swap hard-disk-drive backplane, install 141
3.5-inch hot-swap hard-disk-drive backplane, remove 140
3.5-inch simple-swap hard-disk-drive backplate
assembly, install 144
3.5-inch simple-swap hard-disk-drive backplate
assembly, remove 142

A

ABR, automatic boot recovery 76
ac power LED 17
acoustical noise emissions 6
adapter, install 111
adapter, remove 110
administrator
password 33
air baffle, install 90
air baffle, remove 90
applying current firmware
using best practices 87
ASM event log 9, 57
assertion event, system-event log 56
assistance, getting 661
attention notices 3
Australia Class A statement 668
automatic boot recovery (ABR) 76
availability, server 12

B

backup firmware
starting 34
bays 6
before you install a legacy operating system 28
best practices
use to apply current firmware and device-driver updates 87
bezel, remove 91
blue screen capture features 9
blue-screen capture feature
overview 9, 36
blue-screen feature 36
Boot Manager 34
Boot Manager program 26
Business Partners instructions 87, 173
button, presence detection 18

C

cable
internal routing 158
cable connection
onboard RAID 162
cable routing
operating temperature enhancement kit 159
operator information panel 161
optical 158
power 161
ServeRAID SAS/SATA controller, fixed power supply
model 164, 166
ServeRAID SAS/SATA controller, hot-swap power
supply model 168
ServeRAID SAS/SATA controller, redundant power
supply model 170
cache 6
call home feature
Electronic Service Agent 60
call home tools 60
Canada Class A electronic emission statement 668
caution notices 3
check log LED 15
checkout procedure 50
performing 50
China Class A electronic emission statement 670
Class A electronic emission notice 668
coin-cell battery
install 127
remove 126
collecting data 47
completing
parts replacement 172
Component locations 15
Component locations 15
components
server 19, 77
configuration
information 25
instructions 25
Nx-boot failure 76
ServerGuide Setup and Installation CD 25
Setup Utility 25
configuration programs 26
Configure BIOS for onboard SATA RAID 44
configuring
Ethernet controller 38
RAID arrays 39
with ServerGuide 28
configuring hardware 26
configuring your server 25
connector
USB 15
connectors 22
Ethernet 17

- front of server 15
- on the rear of the server 17
- power supply 17
- rear 17
- serial 17
- USB 17
- video 17
- contamination, particulate and gaseous 6, 667
- controls and LEDs
 - on the operator information panel 18
- cooling 9
- cover, install 89
- cover, remove 88
- CPLD heartbeat
 - LED 55
- creating a personalized support web page 663
- custom support web page 663

D

- danger notices 3
- data collection 47
- dc power LED 17
- deassertion event, system-event log 56
- device drivers 34
- devices, static-sensitive
 - handling guidelines 88
- diagnostic
 - on-board programs, starting 59
 - tools, overview 51
- diagnostics
 - program overview 58
- diagnostics program
 - DSA Preboot 9
- dimensions 6
- dimmm
 - install 97
 - unbuffered 99
- DIMM, install 99
- DIMMs
 - removal 96
- display problems 66
- documentation
 - Documentation Browser 1
 - System x Documentation CD 1
 - using 662
- documentation cd 1
- documentation, updated
 - finding 2
- drive 6
- DSA 173
 - edition 59
 - program, overview 58
 - test log, viewing 60
 - text message format 60
- DSA data
 - how to send to Lenovo 173
- DSA log 9, 56
- DSA Portable 51
- DSA Preboot 51, 59

- DSA Preboot diagnostic program 9
- DSA, sending data 662
- DVD
 - drive activity LED 15
 - drive DVD LED 15
 - eject button 15
- Dynamic System Analysis 173
- Dynamic System Analysis (DSA) Preboot diagnostics program 9

E

- electrical equipment, servicing vii
- electrical input 6
- electronic emission Class A notice 668
- Electronic Service Agent 60
- embedded hypervisor
 - using 37
- enabling
 - Features on Demand
 - Ethernet software 38
- environment 6
- error codes and messages
 - IMM2 175
 - UEFI (POST) 491
- error messages 61
- error messages, IMM2 175
- error symptoms 66
 - general 61
 - hard disk drive 62
 - hypervisor flash device 64
 - intermittent 64
 - keyboard 65
 - memory 65
 - monitor 66
 - mouse 65
 - network connection 68
 - operating system boot 68
 - optical drive 62
 - optional devices 68
 - power 69
 - serial port 70
 - ServerGuide 70
 - software 71
 - USB connector 71
 - USB-device 65
- errors
 - format, DSA code 60
- Ethernet 9, 17
 - controller 72
 - link status LED 17
- Ethernet activity
 - LED 17–18
- Ethernet connector 17
- Ethernet controller configuration 26
- Ethernet controller, configure 38
- Ethernet support 9
- European Union EMC Directive conformance statement 668
- event log 56
 - viewing 56
- event log, POST 56

- event log, system 56
- event logs
 - clearing 57
- event logs, methods for viewing 57
- events, IMM2 175
- expansion bays 6

F

- fan
 - simple-swap 6
- fan, install 125
- fan, remove 124
- fans 9
- FCC Class A notice 668
- features 6
 - ServerGuide 28
- features, remote presence and blue-screen 9
- finding
 - updated documentation 2
- firmware updates 5
- firmware updates best practices 87
- firmware, server, recovering 74
- firmware, updating 25
- fixed power supply
 - remove 129
- fixed power supply, install 130
- flash power module
 - install 115
 - remove 114
- flash power module holder
 - install 95
 - remove 94
- front I/O assembly, install 121
- front I/O assembly, remove 119
- front view
 - connectors 15
 - LED location 15
- front view of the server 15

G

- gaseous contamination 6, 667
- general
 - problems 61
- Germany Class A statement 669
- grease, thermal 150
- guidelines
 - servicing electrical equipment vii
 - system reliability 87
 - trained service technicians vi

H

- handling static-sensitive devices 88
- hard disk drive
 - activity LED 15
 - problems 62
 - status LED 15
- hardware requirements 1

- hardware service and support telephone numbers 663
- hardware, configuring 26
- head output 6
- heat sink, install 148
- heat sink, remove 145
- help
 - from the World Wide Web 662
 - from World Wide Web 662
 - sending diagnostic data 662
 - sources of 661
- hot-swap hard disk drive
 - install 101
 - remove 100
- hot-swap power supply
 - remove 131
- hot-swap power supply, install 133
- how to send DSA data to Lenovo 173
- humidity 6
- hypervisor flash device
 - problems 64
- hypervisor flash device, install 118
- hypervisor flash device, removal 117

I

- IMM2 26
- IMM2 error messages 175
- IMM2 events 175
- IMM2 heartbeat
 - LED 55
- IMM2 host name 36
- IMM2 Web interface 37
- important notices 3, 666
- in-band
 - automated boot recovery method 75
 - manual recovery method 75
- information center 662
- inspecting for unsafe conditions vi
- installation 5
- installing
 - 2.5-inch hot-swap hard-disk-drive backplane 137
 - 2.5-inch simple-swap hard-disk-drive backplate assembly 139
 - 3.5-inch hot-swap hard-disk-drive backplane 141
 - 3.5-inch simple-swap hard-disk-drive backplate assembly 144
 - adapter 111
 - air baffle 90
 - coin-cell battery 127
 - cover 89
 - dimmm 97
 - DIMM 99
 - fan 125
 - fixed power supply 130
 - flash power module 115
 - flash power module holder 95
 - front I/O assembly 121
 - heat sink 148
 - hot-swap hard disk drive 101
 - hot-swap power supply 133

- hypervisor flash device 118
- memory 97
- operating temperature enhancement kit 123
- operating temperature enhancement kit cable 123
- operator information panel 121
- optical drive 109
- PCI riser-card bracket 135
- power distribution board 154
- power distribution board cover 152
- RAID adapter battery 115
- RAID adapter battery holder 95
- second microprocessor 148
- security bezel 92
- server components 88
- ServeRAID SAS/SATA controller memory module 113
- simple-swap hard disk drive 105
- structural parts 88
- system board 157
- the PCI riser-card assembly 94
- Tier 1 CRUs 96
- usb cable 121
- instructions for Business Partners 87, 173
- integrated baseboard management controller 13
- integrated functions 6
- integrated management module
 - event log 9
 - overview 9
- integrated management module II
 - event log 56–57
 - programs 26
- Integrated Management Module II (IMM2)
 - using 35
- intermittent
 - problems 64
- internal cable routing 158
- introduction 5
- IP address for the IMM2 36
- IPMI event log 9, 56–57
- IPMItool 57

J

- Japan Class A electronic emission statement 669
- Japanese statement for ac power consumption for JEITA harmonics guideline 670
- Japanese statement of compliance for products less than or equal to 20 A per phase for JEITA harmonics guideline 670
- jumper
 - UEFI boot recovery 74
- jumpers
 - system board 22

K

- Korea Class A electronic emission statement 670

L

- LED

- ac power 17
- CPLD heartbeat 55
- dc power 17
- DVD drive activity 15
- Ethernet activity 17–18
- Ethernet-link status 17
- hard disk drive activity 15
- hard disk drive status 15
- IMM2 heartbeat 55
- power supply error 17
- power-on 18
- system information 18
- system locator 18
- system pulse 55
- system-error 18
- LEDs
 - front of server 15
 - light path diagnostics 53
 - power-supply 53–54
 - on the system board 24
 - operator information panel 18, 53
 - power-supply 53–54
 - power-supply detected problems 53–54
- legacy operating system
 - requirement 28
- Lenovo ToolsCenter Suite CLI log 57
- Lenovo ToolsCenter Suite CLI program
 - overview 39
- Lenovo XClarity Administrator
 - updating 39
- Lenovo, next generation technology 9
- light path diagnostics 53
 - panel 53
- light path diagnostics, viewing without power 53
- local area network (LAN) 9
- locator LED 15
- logging 37

M

- management, system 9
- memory 9
 - install 97
 - specifications 6
 - UDIMM 97
 - unbuffered 99
- memory module
 - removing 96
- memory support 9
- menu choices
 - Setup Utility 29
- messages, error
 - POST 491
- method 76
- methods, viewing event logs 57
- microprocessor 9
 - specifications 6
- model name
 - location 73

N

- New Zealand Class A statement 668
- next generation technology 9
- NMI button 17
- noise emissions 6
- NOS installation
 - with ServerGuide 28
 - without ServerGuide 28
- notes 3
- notes, important 666
- notices 3, 665
 - electronic emission 668
 - FCC, Class A 668
- Nx-boot failure 76

O

- obtaining 36
- onboard RAID
 - cable connection 162
- onboard RAID signal cable connection 162
- online documentation 5
- online publications 2
- operating system 1
- operating temperature enhancement kit
 - cable routing 159
- operating temperature enhancement kit cable routing 159
- operating temperature enhancement kit cable, install 123
- operating temperature enhancement kit cable, remove 121
- operating temperature enhancement kit, install 123
- operating temperature enhancement kit, remove 121
- operating-system event log 9, 56–57
- operator information panel
 - cable routing 161
 - controls and LEDs 18
 - LEDs 18, 53
- operator information panel cable routing 161
- operator information panel, install 121
- operator information panel, remove 119
- optical
 - cable routing 158
- optical cable routing 158
- optical drive
 - problems 62
- optical drive, install 109
- optical drive, remove 106
- optional device problems 68
- out-of-band 76

P

- particulate contamination 6, 667
- parts listing 77
- parts replacement, completing 172
- parts, structural 83
- password 32
 - administrator 32
 - power-on 32
- password, power-on
 - switch on system board 33

- PCI
 - slot 1 17
 - slot 2 17
- PCI expansion slots 6
- PCI riser card, remove 135
- PCI riser-card assembly, remove 93
- PCI riser-card bracket, remove 135
- People's Republic of China Class A electronic emission statement 670
- policy option 34
- POST
 - error codes 491
 - event log 56
- POST event log 56
- POST, intro 58
- power 34
 - cable routing 161
 - power-control button 15
 - requirement 6
 - specifications 6
 - supply 6
- power cable routing 161
- power cords 83
- power distribution board cover
 - installing 152
- power distribution board, install 154
- power distribution board, remove 153
- power features
 - of the server 13
- power on and working inside the server 87
- power problems 69, 71
- power supplies
 - redundancy support 9
- power supply 6
- power-control button 15
- power-on LED 13, 18
- power-on self-test 58
- power-supply
 - LEDs 53–54
 - LEDs and detected problems 53–54
- power-supply LEDs 53–54
- Preboot, DSA diagnostics program 9
- presence detection button 18
- problems 66
 - Ethernet controller 72
 - general 61
 - hard disk drive 62
 - hypervisor flash device 64
 - intermittent 64
 - keyboard 65
 - memory 65
 - monitor 66
 - mouse 65
 - network connection 68
 - operating system boot 68
 - optical drive 62
 - optional devices 68
 - power 69, 71
 - serial port 70
 - ServerGuide 70

- software 71
- undetermined 72
- USB connector 71
- procedure, checkout 50
- product service, Taiwan 663
- program
 - Lenovo ToolsCenter Suite CLI 39

R

- RAID adapter
 - battery holder
 - install 95
 - remote battery
 - install 115
 - remove 114
- RAID adapter battery
 - install 115
 - remove 114
- RAID adapter battery holder
 - install 95
- RAID arrays
 - configuring 39
- RAS features, server 12
- rear view 17
 - of the server 17
- recovering the server firmware 74
- redundancy support
 - power supplies 9
- redundant 9
 - cooling 9
 - Ethernet connection 9
- Redundant
 - Ethernet capabilities 12
 - hot-swap power supplies 12
- reliability, server 12
- remote presence feature
 - using 36
- removing
 - 2.5-inch hot-swap hard-disk-drive backplane 136
 - 2.5-inch simple-swap hard-disk-drive backplate assembly 138
 - 3.5-inch hot-swap hard-disk-drive backplane 140
 - 3.5-inch simple-swap hard-disk-drive backplate assembly 142
 - adapter 110
 - air baffle 90
 - bezel 91
 - coin-cell battery 126
 - cover 88
 - fan 124
 - fixed power supply 129
 - flash power module 114
 - flash power module holder 94
 - front I/O assembly 119
 - heat sink 145
 - hot-swap hard disk drive 100
 - hot-swap power supply 131
 - hypervisor flash device 117
 - memory modules 96

- operating temperature enhancement kit 121
- operating temperature enhancement kit cable 121
- operator information panel 119
- optical drive 106
- PCI riser card 135
- PCI riser-card assembly 93
- power distribution board 153
- power distribution board cover 151
- RAID adapter battery 114
- second microprocessor 145
- server components 87–88
- ServeRAID SAS/SATA controller memory module 113
- simple-swap hard disk drive 103
- system board 155
- Tier 1 CRUs 96
- usb cable 119
- removing and installing
 - removing
 - structural parts 88
 - server components 88
 - structural parts 88
 - Tier 1 CRUs 96
 - removing, DIMMs 96
- Replaceable server components 77
- replacing
 - server components 87
 - Tier 2 CRUs 145
- requirements
 - hardware 1
 - software 1
- reset button 15
- returning
 - component 174
 - device 174
- Russia Class A electronic emission statement 670

S

- safety v
- Safety Information 3
- safety statements v, viii
- second microprocessor, install 148
- second microprocessor, remove 145
- security bezel, install 92
- sending diagnostic data 662
- sending DSA data
 - to Lenovo 173
- serial connector 17
- serial number
 - location 73
- serial port problems 70
- server
 - offerings 9
 - power features 13
 - turn off 13
 - turn on 13
 - working inside with the power on 87
- server , backup firmware
 - starting 34
- server components 19, 77

- server firmware, recovering 74
- server rear view 17
- server shutdown 13
- server, front view 15
- ServeRAID SAS/SATA controller cable routing, fixed
 - power supply model 164, 166
- ServeRAID SAS/SATA controller cable routing, hot-swap
 - power supply model 168
- ServeRAID SAS/SATA controller cable routing, redundant
 - power supply model 170
- ServeRAID SAS/SATA controller memory module, install 113
- ServeRAID SAS/SATA controller memory module, remove 113
- ServeRAID SAS/SATA controller, fixed power supply model
 - cable routing 164, 166
- ServeRAID SAS/SATA controller, hot-swap power supply
 - model
 - cable routing 168
- ServeRAID SAS/SATA controller, redundant power supply
 - model
 - cable routing 170
- ServeRAID support 9
- ServerGuide
 - features 28
 - NOS installation 28
 - setup 28
 - Setup and Installation CD 25
 - using 27
- ServerGuide CD 9
- service and support
 - before you call 661
 - hardware 663
 - software 663
- service bulletins 49
- serviceability, server 12
- servicing electrical equipment vii
- Setup Utility 25–26
 - menu choices 29
 - starting 29
 - using 28
- shutting down the server 13
- simple-swap hard disk drive
 - install 105
 - remove 103
- size 6
- slots
 - PCI expansion 6
- software problems 71
- software requirements 1
- software service and support telephone numbers 663
- specifications 6
- standby mode 13
- starting
 - Setup Utility 29
 - the backup firmware 34
- static-sensitive devices
 - handling guidelines 88
- structural parts 83
- support web page, custom 663
- switch block 22
- switches

- system board 22
- system
 - error LED front 18
 - information LED 18
 - locator LED, front 18
- system board
 - connectors 22
 - LEDs 24
 - power-on password switch 33
 - switches and jumpers 22
- system board internal connectors 22
- system board, install 157
- system board, remove 155
- system event log 56
- system pulse LEDs 55
- system reliability guidelines 87
- system-error LED 15
- system-event log 56
- system-event log, assertion event 56
- system-event log, deassertion event 56
- Systems Director 9
- systems management 9

T

- Taiwan BSMI RoHS declaration 672
- Taiwan Class A electronic emission statement 671
- Taiwan product service 663
- telecommunication regulatory statement 667
- telephone numbers 663
- temperature 6
- test log, viewing 60
- the PCI riser-card assembly, install 94
- thermal grease 150
- Tier 1 CRUs, install 96
- Tier 2 CRUs, replacement 145
- TOE 6
- tools, call home 60
- tools, diagnostic 51
- TPM switch block description 22
- trademarks 666
- trained service technicians, guidelines vi
- troubleshooting 47
 - symptom 61
- turning off the server 13
 - integrated baseboard management controller 13
- turning on the server 13

U

- UDIMM
 - considerations 99
 - requirement 97, 99
- UEFI
 - boot recovery jumper 74
 - error codes 491
- unbuffered
 - dimmm 99
 - memory 99

- Unbuffered DIMM 97, 99
- undetermined problems 72
- undocumented problems 49
- United States FCC Class A notice 668
- Universal Serial Bus (USB) problems 71
- unsafe conditions, inspecting for vi
- UpdateXpress 25, 34
- updating
 - DMI/SMBIOS 42
 - firmware 25
 - Lenovo XClarity Administrator 39
 - Universal Unique Identifier (UUID) 40
- USB
 - connector 15, 17
- usb cable, install 121
- usb cable, remove 119
- using
 - embedded hypervisor 37
 - Setup Utility 28
 - the remote presence feature 36
- using best practices
 - to apply firmware and device-driver updates 87
- using Integrated Management Module II (IMM2) 35
- utility, Setup 26
 - starting 29
 - using 28

V

- VGA connector
 - rear 17
- video controller, integrated
 - specifications 6
- viewing event log 57
- VMware Hypervisor support 26

W

- Wake on LAN feature 13
- weight 6
- what the server offers 9
- working inside with the power on 87

X

- x3250
 - introduction 5

Lenovo[™]