

FCC TEST REPORT

FCC ID: 2AW96-M700S

Report Number : ZKT-221109L8361-03

Date of Test..... : Nov. 07, 2022 -- Nov. 25, 2022

Date of issue..... : Nov. 25, 2022

Total number of pages : 103

Test Result..... : PASS

Testing Laboratory : **Shenzhen ZKT Technology Co., Ltd.**

Address : 1/F, No. 101, Building B, No. 6, Tangwei Community Industrial Avenue, Fuhai Street, Bao'an District, Shenzhen, China

Applicant's name : Telstar USA LLC

Address : 9817 Valley View Road, Eden Prairie, MN, US

Manufacturer's name : Shenzhen Orange Digital Technology Co., Ltd

Address : Room 2305, Building 2, Phase 6, Vanke Yuncheng, Tongfa South Road, Xili Community, Xili Street, Nanshan District, Shenzhen

Test specification:

Standard : FCC CFR Title 47 Part 15 Subpart C Section 15.247
ANSI C63.10:2013

Test procedure..... : KDB558074 D0115.247 Meas Guidance v 05r02

Non-standard test method : N/A

Test Report Form No. : TRF-EL-110_V0

Test Report Form(s) Originator : ZKT Testing

Master TRF : Dated: 2020-01-06

This device described above has been tested by ZKT, and the test results show that the equipment under test (EUT) is in compliance with the FCC requirements. And it is applicable only to the tested sample identified in the report.

This report shall not be reproduced except in full, without the written approval of ZKT, this document may be altered or revised by ZKT, personal only, and shall be noted in the revision of the document.

Product name..... : Projector

Trademark : 

Model/Type reference : M700S

Ratings : DC 19V/3.42A from adapter
DC10.8V from battery

Testing procedure and testing location:

Testing Laboratory: **Shenzhen ZKT Technology Co., Ltd.**

Address: 1/F, No. 101, Building B, No. 6, Tangwei Community
Industrial Avenue, Fuhai Street, Bao'an District,
Shenzhen, China

Tested by (name + signature): Alen He

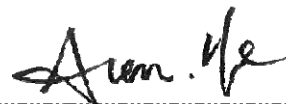

Reviewer (name + signature).....: Joe Liu



Approved (name + signature): Lake Xie



Table of Contents

	Page
1. VERSION	5
2. SUMMARY OF TEST RESULTS	6
2.1 TEST FACILITY	6
2.2 MEASUREMENT UNCERTAINTY	6
3. GENERAL INFORMATION	7
3.1 GENERAL DESCRIPTION OF EUT	7
3.2 DESCRIPTION OF TEST MODES	8
3.3 BLOCK DIGRAM SHOWING THE CONFIGURATION OF SYSTEM TESTED	9
3.4 DESCRIPTION OF SUPPORT UNITS(CONDUCTED MODE)	9
3.5EQUIPMENTS LIST FOR ALL TEST ITEMS	10
4. EMC EMISSION TEST	11
4.1 CONDUCTED EMISSION MEASUREMENT	11
4.1.1 POWER LINE CONDUCTED EMISSION LIMITS	11
4.1.2 TEST PROCEDURE	11
4.1.3 DEVIATION FROM TEST STANDARD	11
4.1.4 TEST SETUP	12
4.1.5 EUT OPERATING CONDITIONS	12
4.1.6 TEST RESULT	13
4.2 RADIATED EMISSION MEASUREMENT	15
4.2.1 RADIATED EMISSION LIMITS	15
4.2.2 TEST PROCEDURE	15
4.2.3 DEVIATION FROM TEST STANDARD	16
4.2.4 TEST SETUP	16
4.2.5 EUT OPERATING CONDITIONS	17
4.2.6 TEST RESULTS	17
5.RADIATED BAND EMISSIONMEASUREMENT	30
5.1 TEST REQUIREMENT:	30
5.2 TEST PROCEDURE	30
5.3 DEVIATION FROM TEST STANDARD	30
5.4 TEST SETUP	31
5.5 EUT OPERATING CONDITIONS	31
5.6 TEST RESULT	32
6.POWER SPECTRAL DENSITY TEST	37
6.1 APPLIED PROCEDURES / LIMIT	37
6.2 TEST PROCEDURE	37
6.3 DEVIATION FROM STANDARD	37
6.4 TEST SETUP	37
6.5 EUT OPERATION CONDITIONS	37

6.6 TEST RESULT	38
7. CHANNEL BANDWIDTH	39
7.1 APPLIED PROCEDURES / LIMIT	39
7.2 TEST PROCEDURE	39
7.3 DEVIATION FROM STANDARD	39
7.4 TEST SETUP	39
7.5 EUT OPERATION CONDITIONS	39
7.6 TEST RESULT	40
8. OUTPUT POWER TEST	41
8.1 APPLIED PROCEDURES/LIMIT	41
8.2 TEST PROCEDURE	41
8.3 DEVIATION FROM STANDARD	41
8.4 TEST SETUP	41
8.5 EUT OPERATION CONDITIONS	41
8.6 TEST RESULT	41
9. CONDUCTED BAND EDGE AND SPURIOUS EMISSION	42
9.1 APPLICABLE STANDARD	42
9.2 TEST PROCEDURE	42
9.3 DEVIATION FROM STANDARD	42
9.4 TEST SETUP	42
9.5 EUT OPERATION CONDITIONS	42
9.6 TEST RESULTS	42
10. ANTENNA REQUIREMENT	43
11.1. -6DB BANDWIDTH	44
11.3. BANDEDGE	57
11.4. MAX. OUTPUT POWER	65
11.5. POWER SPECTRAL DENSITY	66
11.6. SPURIOUS EMISSION	79
12. TEST SETUP PHOTO	103
13. EUT CONSTRUCTIONAL DETAILS	103

1. VERSION

Report No.	Version	Description	Approved
ZKT-221109L8361-03	Rev.01	Initial issue of report	Nov. 25, 2022

2. SUMMARY OF TEST RESULTS

Test procedures according to the technical standards:

FCC Part15 (15.247) , Subpart C			
Standard Section	Test Item	Result	Remark
FCC part 15.203/15.247 (c)	Antenna requirement	PASS	
FCC part 15.207	AC Power Line Conducted Emission	PASS	
FCC part 15.247 (b)(3)	Conducted Peak Output Power	PASS	
FCC part 15.247 (a)(2)	Channel Bandwidth& 99% OCB	PASS	
FCC part 15.247 (e)	Power Spectral Density	PASS	
FCC part 15.247(d)	Band Edge	PASS	
FCC part 15.205/15.209	Spurious Emission	PASS	

NOTE:

(1) "N/A" denotes test is not applicable in this Test Report

2.1 TEST FACILITY

Shenzhen ZKT Technology Co., Ltd.

Add. : 1/F, No. 101, Building B, No. 6, Tangwei Community Industrial Avenue, Fuhai Street, Bao'an District, Shenzhen, China

FCC Test Firm Registration Number: 692225

Designation Number: CN1299

IC Registered No.: 27033

2.2 MEASUREMENT UNCERTAINTY

The reported uncertainty of measurement $y \pm U$, where expanded uncertainty U is based on a standard uncertainty multiplied by a coverage factor of $k=2$, providing a level of confidence of approximately 95 %.

No.	Item	Uncertainty
1	Conducted Emission Test	$\pm 1.38\text{dB}$
2	RF power conducted	$\pm 0.16\text{dB}$
3	Spurious emissions conducted	$\pm 0.21\text{dB}$
4	All emissions radiated(<1G)	$\pm 4.68\text{dB}$
5	All emissions radiated(>1G)	$\pm 4.89\text{dB}$
6	Temperature	$\pm 0.5\text{C}$
7	Humidity	$\pm 2\%$

3. GENERAL INFORMATION

3.1 GENERAL DESCRIPTION OF EUT

Product Name:	Projector
Model No.:	M700S
Serial No.:	N/A
Hardware Version:	M3_MBV1_1
Software Version:	N/A
Sample(s) Status:	Engineer sample
Frequency range:	802.11b/802.11g /802.11n(HT20): 2412MHz -2462MHz 802.11n(HT40): 2422MHz -2452MHz
Channel numbers:	802.11b/802.11g /802.11n(HT20):11 802.11n(HT40):7
Channel separation:	5MHz
Modulation technology:	802.11b: Direct Sequence Spread Spectrum(DSSS) 802.11g/802.11n(H20)/802.11n(HT40): Orthogonal Frequency Division Multiplexing(OFDM)
Antenna Type:	FPC antenna
Antenna gain:	ANT1:4.16dBi; ANT1:4.81dBi; MIMO:7.82dBi
Power supply:	DC 19V/3.42A from adapter DC10.8V from battery

Operation Frequency each of channel							
Channel	Frequency	Channel	Frequency	Channel	Frequency	Channel	Frequency
1	2412MHz	4	2427MHz	7	2442MHz	10	2457MHz
2	2417MHz	5	2432MHz	8	2447MHz	11	2462MHz
3	2422MHz	6	2437MHz	9	2452MHz	X	

Note:

In section 15.31(m), regards to the operating frequency range over 10 MHz, the Lowest frequency, the middle frequency, and the highest frequency of channel were selected to perform the test, and the selected channel see below:

Test channel	Frequency (MHz)
	802.11b/802.11g /802.11n(HT20)
Lowest channel	2412MHz
Middle channel	2437MHz
Highest channel	2462MHz

Test channel	Frequency (MHz)
	802.11n(HT40)

Lowest channel	2422MHz
Middle channel	2437MHz
Highest channel	2452MHz

Worst Case Configuration

Description	MIMO (802.11N-HT20)
Antenna	MIMO
Channel	1
Data Rate (Mbps)	MCS7

3.2 DESCRIPTION OF TEST MODES

Transmitting mode	Keep the EUT in continuously transmitting mode
Remark: During the test, the duty cycle >98%, the test voltage was tuned from 85% to 115% of the nominal rated supply voltage, and found that the worst case was under the nominal rated supply condition. So the report just shows that condition's data.	

We have verified the construction and function in typical operation. All the test modes were carried out with the EUT in transmitting operation, which was shown in this test report and defined as follows:

Pre-scan all kind of data rate in lowest channel, and found the follow list which it was worst case.

Mode	802.11b	802.11g	802.11n (HT20)	802.11n (HT40)
Data rate	11Mbps	54Mbps	MCS7	MCS7

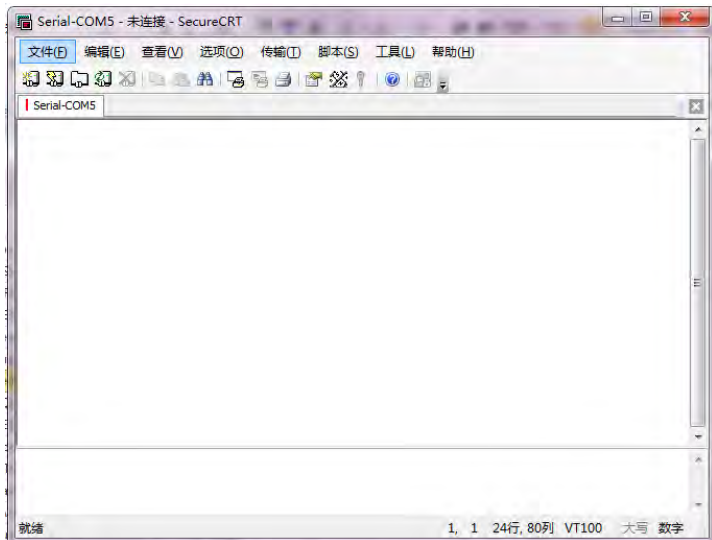
Test Software	BT Test Tool 
Power level setup	<10dBm

3.3 BLOCK DIGRAM SHOWING THE CONFIGURATION OF SYSTEM TESTED

Conducted Emission



Radiated Emission

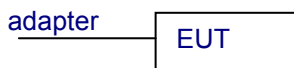

Conducted Spurious

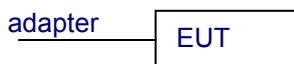

3.4 DESCRIPTION OF SUPPORT UNITS(CONDUCTED MODE)

The EUT has been tested as an independent unit together with other necessary accessories or support units. The following support units or accessories were used to form a representative test configuration during the tests.

Item	Equipment	Mfr/Brand	Model/Type No.	Series No.	Note
1	adapter	Shenzhen JingQuanHua Electronics Co.,Ltd.	NSA65EH-19034200	/	SDOC
2	remote control	Shenzhen Orange Digital Technology Co.,Ltd	/	/	SDOC

Item	Shielded Type	Ferrite Core	Length	Note

Note:

- (1) The support equipment was authorized by Declaration of Confirmation.
- (2) For detachable type I/O cable should be specified the length in cm in 『Length』 column.

3.5EQUIPMENTS LIST FOR ALL TEST ITEMS

Radiation Test equipment

Item	Equipment	Manufacturer	Type No.	Serial No.	Last calibration	Calibrated until
1	Spectrum Analyzer (9kHz-26.5GHz)	KEYSIGHT	9020A	MY55370835	Oct. 18, 2022	Oct. 17, 2023
2	Spectrum Analyzer (1GHz-40GHz)	R&S	FSQ	100363	Oct. 17, 2022	Oct. 16, 2023
3	EMI Test Receiver (9kHz-7GHz)	R&S	ESCI7	101169	Oct. 18, 2022	Oct. 17, 2023
4	Bilog Antenna (30MHz-1500MHz)	Schwarzbeck	VULB9168	N/A	Oct. 17, 2022	Oct. 16, 2023
5	Horn Antenna (1GHz-18GHz)	Agilent	AH-118	071145	Oct. 17, 2022	Oct. 16, 2023
6	Loop Antenna	TESEQ	HLA6121	58357	Oct. 17, 2022	Oct. 16, 2023
7	Amplifier (30-1000MHz)	EM Electronics	EM330 Amplifier	060747	Oct. 17, 2022	Oct. 16, 2023
8	Amplifier (1GHz-26.5GHz)	Agilent	8449B	3008A00315	Oct. 18, 2022	Oct. 17, 2023
9	RF cables1 (9kHz-30MHz)	N/A	9kHz-30MHz	N/A	Oct. 18, 2022	Oct. 17, 2023
10	RF cables2 (30MHz-1GHz)	N/A	30MHz-1GHz	N/A	Oct. 18, 2022	Oct. 17, 2023
11	RF cables3 (1GHz-40GHz)	N/A	1GHz-40GHz	N/A	Oct. 18, 2022	Oct. 17, 2023
12	ESG Signal Generator	Agilent	E4421B	N/A	Oct. 18, 2022	Oct. 17, 2023
13	Signal Generator	Agilent	N5182A	N/A	Oct. 22, 2022	Oct. 21, 2023
14	Magnetic Field Probe Tester	Narda	ELT-400	0-0344	Oct. 17, 2022	Oct. 16, 2023
15	MWRF Power Meter Test system	MW	MW100-RPC B	N/A	Oct. 22, 2022	Oct. 21, 2023
16	Power sensor	KEYSIGHT	U200H	MY51190005	Oct. 22, 2022	Oct. 21, 2023
17	D.C. Power Supply	LongWei	TPR-6405D	N/A	\	\
18	EMC Software	Frad	EZ-EMC	Ver.EMC-CON 3A1.1	\	\
19	RF Software	MW	MTS8310	V2.0.0.0	\	\
20	Turntable	MF	MF-7802BS	N/A	\	\
21	Antenna tower	MF	MF-7802BS	N/A	\	\

Conduction Test equipment

Item	Kind of Equipment	Manufacturer	Type No.	Serial No.	Last calibration	Calibrated until
1	LISN	R&S	ENV216	101471	Oct. 22, 2022	Oct. 21, 2023
2	LISN	CYBERTEK	EM5040A	E1850400149	Oct. 22, 2022	Oct. 21, 2023
3	Test Cable	N/A	C01	N/A	Oct. 18, 2022	Oct. 17, 2023
4	Test Cable	N/A	C02	N/A	Oct. 18, 2022	Oct. 17, 2023
5	EMI Test Receiver	R&S	ESCI3	101393	Oct. 17, 2022	Oct. 16, 2023
6	EMC Software	Frad	EZ-EMC	Ver.EMC-CON 3A1.1	\	\

4. EMC EMISSION TEST

4.1 CONDUCTED EMISSION MEASUREMENT

Test Requirement:	FCC Part15 C Section 15.207
Test Method:	ANSI C63.10:2013
Test Frequency Range:	150KHz to 30MHz
Receiver setup:	RBW=9KHz, VBW=30KHz, Sweep time=auto

4.1.1 POWER LINE CONDUCTED EMISSION LIMITS

FREQUENCY (MHz)	Limit (dBuV)		Standard
	Quasi-peak	Average	
0.15 -0.5	66 - 56 *	56 - 46 *	FCC
0.50 -5.0	56.00	46.00	FCC
5.0 -30.0	60.00	50.00	FCC

Note:

(1) *Decreases with the logarithm of the frequency.

4.1.2 TEST PROCEDURE

1. The equipment was set up as per the test configuration to simulate typical actual usage per the user's manual. The EUT is a tabletop system; a wooden table with a height of 0.8 meters is used and is placed on the ground plane as per ANSI C63.10:2013.
2. Support equipment, if needed, was placed as per ANSI C63.10:2013
3. All I/O cables were positioned to simulate typical actual usage as per ANSI C63.10:2013.
4. The adapter received AC120V/60Hz power through a Line Impedance Stabilization Network (LISN) which supplied power source and was grounded to the ground plane.
5. All support equipments received AC power from a second LISN, if any.
6. The EUT test program was started. Emissions were measured on each current carrying line of the EUT using a spectrum Analyzer / Receiver connected to the LISN powering the EUT. The LISN has two monitoring points: Line 1 (Hot Side) and Line 2 (Neutral Side). Two scans were taken: one with Line 1 connected to Analyzer / Receiver and Line 2 connected to a 50 ohm load; the second scan had Line 1 connected to a 50 ohm load and Line 2 connected to the Analyzer / Receiver.
7. Analyzer / Receiver scanned from 150 KHz to 30MHz for emissions in each of the test modes e.
8. For the actual test configuration, please refer to the related Item –EUT Test Photos.

4.1.3 DEVIATION FROM TEST STANDARD

No deviation

4.1.4 TEST SETUP

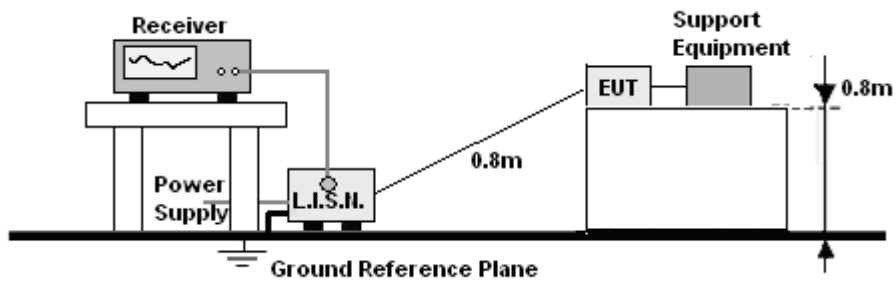

4.1.5 EUT OPERATING CONDITIONS

The EUT was configured for testing in a typical fashion (as a customer would normally use it). The EUT has been programmed to continuously transmit during test. This operating condition was tested and used to collect the included data.

We pretest AC 120V and AC 240V, the worst voltage was AC 120V and the data recording in the report.

4.1.6 TEST RESULT

Temperature :	26°C	Relative Humidity:	54%
Pressure :	101kPa	Phase	L
Test Voltage :	AC 120V/60Hz		

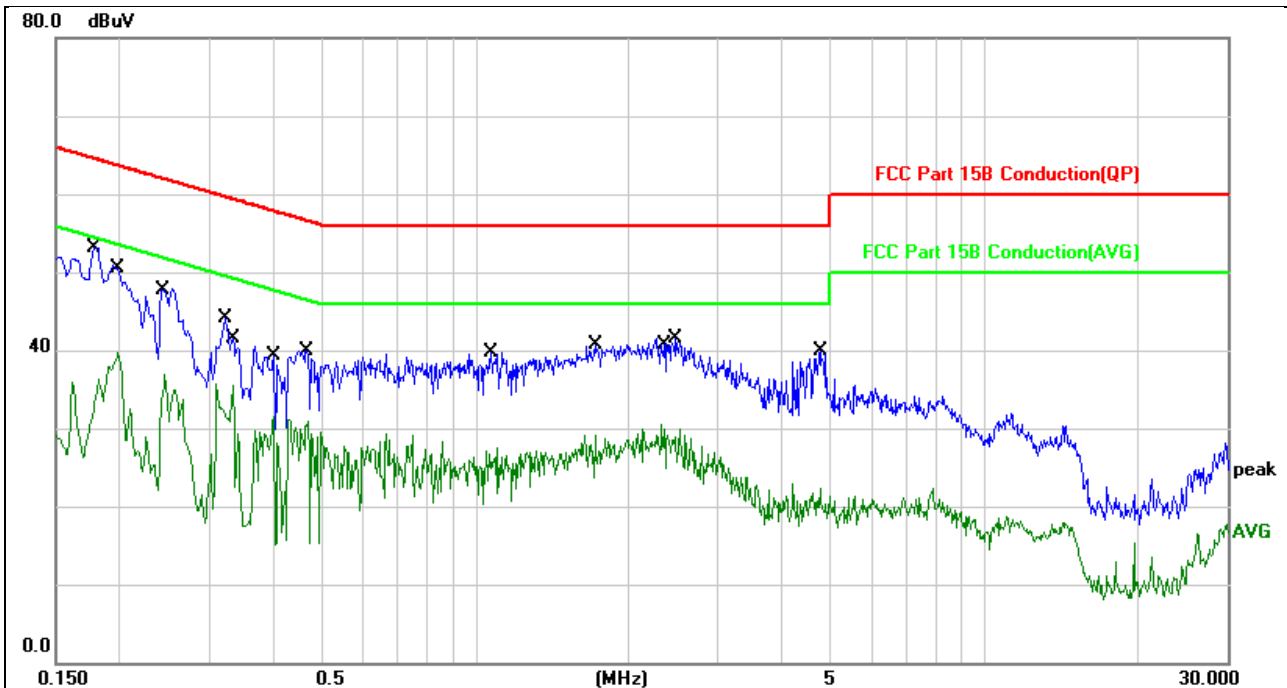

No.	Mk.	Freq. MHz	Reading Level dBuV	Correct Factor dB	Measure- ment dBuV	Limit dBuV	Over dB	Detector	Comment
1	*	0.1776	43.44	9.75	53.19	64.59	-11.40	QP	
2		0.1985	29.96	9.75	39.71	53.67	-13.96	AVG	
3		0.2454	27.08	9.77	36.85	51.91	-15.06	AVG	
4		0.3215	34.28	9.87	44.15	59.67	-15.52	QP	
5		0.3337	25.61	9.86	35.47	49.36	-13.89	AVG	
6		0.4018	21.72	9.87	31.59	47.82	-16.23	AVG	
7		0.4686	20.94	9.86	30.80	46.54	-15.74	AVG	
8		1.0709	29.99	9.75	39.74	56.00	-16.26	QP	
9		1.7161	31.09	9.67	40.76	56.00	-15.24	QP	
10		2.3212	20.95	9.63	30.58	46.00	-15.42	AVG	
11		2.4735	31.78	9.69	41.47	56.00	-14.53	QP	
12		4.7464	30.30	9.67	39.97	56.00	-16.03	QP	

Notes:

1. An initial pre-scan was performed on the line and neutral lines with peak detector.
2. Quasi-Peak and Average measurement were performed at the frequencies with maximized peak emission.
3. Measurement Level = Reading level + Correct Factor

Temperature :	26°C	Relative Humidity:	54%
Pressure :	101kPa	Phase :	N
Test Voltage :	AC 120V/60Hz		

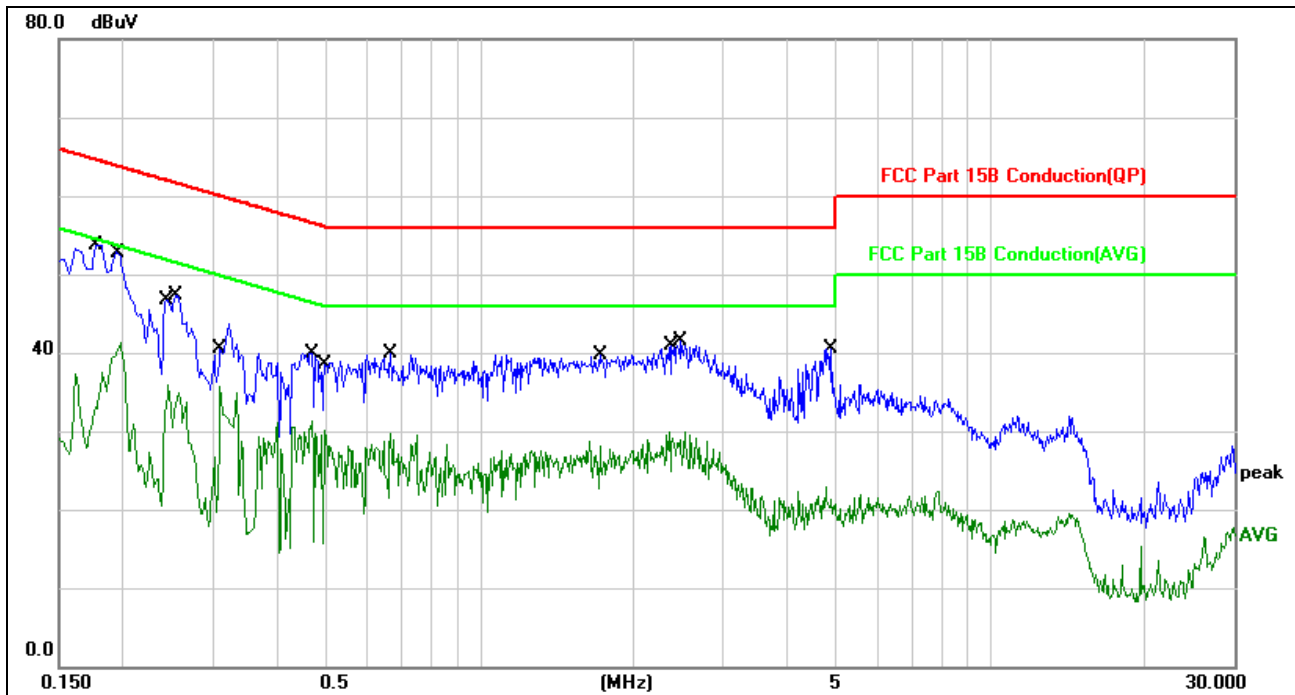

No.	Mk.	Freq. MHz	Reading Level dBuV	Correct Factor dB	Measure- ment dBuV	Limit dBuV	Over dB	Detector	Comment
1	*	0.1768	43.95	9.75	53.70	64.63	-10.93	QP	
2		0.1975	31.57	9.75	41.32	53.71	-12.39	AVG	
3		0.2454	26.08	9.77	35.85	51.91	-16.06	AVG	
4		0.2535	37.56	9.77	47.33	61.64	-14.31	QP	
5		0.3099	25.75	9.87	35.62	49.97	-14.35	AVG	
6		0.4686	21.44	9.86	31.30	46.54	-15.24	AVG	
7		0.4966	20.22	9.85	30.07	46.06	-15.99	AVG	
8		0.6683	30.08	9.83	39.91	56.00	-16.09	QP	
9		1.7161	30.09	9.67	39.76	56.00	-16.24	QP	
10		2.3460	20.22	9.63	29.85	46.00	-16.15	AVG	
11		2.4735	31.78	9.69	41.47	56.00	-14.53	QP	
12		4.8738	30.93	9.66	40.59	56.00	-15.41	QP	

Notes:

1. An initial pre-scan was performed on the line and neutral lines with peak detector.
2. Quasi-Peak and Average measurement were performed at the frequencies with maximized peak emission.
3. Measurement Level = Reading level + Correct Factor
4. The test data shows only the worst case- MIMO (802.11N-HT20 low channel)

4.2 RADIATED EMISSION MEASUREMENT

Test Requirement:	FCC Part15 C Section 15.209				
Test Method:	ANSI C63.10:2013				
Test Frequency Range:	9kHz to 25GHz				
Test site:	Measurement Distance: 3m				
Receiver setup:	Frequency	Detector	RBW	VBW	Value
	9KHz-150KHz	Quasi-peak	200Hz	600Hz	Quasi-peak
	150KHz-30MHz	Quasi-peak	9KHz	30KHz	Quasi-peak
	30MHz-1GHz	Quasi-peak	120KHz	300KHz	Quasi-peak
	Above 1GHz	Peak	1MHz	3MHz	Peak
Peak		1MHz	10Hz	Average	

4.2.1 RADIATED EMISSION LIMITS

Frequencies (MHz)	Field Strength (micorvolts/meter)	Measurement Distance (meters)
0.009~0.490	2400/F(KHz)	300
0.490~1.705	24000/F(KHz)	30
1.705~30.0	30	30
30~88	100	3
88~216	150	3
216~960	200	3
Above 960	500	3

LIMITS OF RADIATED EMISSION MEASUREMENT

FREQUENCY (MHz)	Limit (dBuV/m) (at 3M)	
	PEAK	AVERAGE
Above 1000	74	54

Notes:

- (1) The limit for radiated test was performed according to FCC PART 15C.
- (2) The tighter limit applies at the band edges.
- (3) Emission level (dBuV/m)=20log Emission level (uV/m).

4.2.2 TEST PROCEDURE

Below 1GHz test procedure as below:

- a. The EUT was placed on the top of a rotating table 0.1 meters above the ground at a 3 meter semi-anechoiccamber. The table was rotated 360 degrees to determine the position of the highest radiation.
- b. The EUT was set 3 meters away from the interference-receiving antenna, which was mounted on the top of variable-height antenna tower.

- c. The antenna height is varied from one meter to four meters above the ground to determine the maximum value of the field strength. Both horizontal and vertical polarizations of the antenna are set to make the measurement.
- d. For each suspected emission, the EUT was arranged to its worst case and then the antenna was tuned to heights from 1 meter to 4 meters (for the test frequency of below 30MHz, the antenna was tuned to heights 1 meter) and the rotatable table was turned from 0 degrees to 360 degrees to find the maximum reading.
- e. The test-receiver system was set to Peak Detect Function and Specified Bandwidth with Maximum Hold Mode.
- f. If the emission level of the EUT in peak mode was 10dB lower than the limit specified, then testing could be stopped and the peak values of the EUT would be reported. Otherwise the emissions that did not have 10dB margin would be re-tested one by one using peak, quasi-peak or average method as specified and then reported in a data sheet.

Above 1GHz test procedure as below:

- g. Different from above is the test site, change from Semi- Anechoic Chamber to fully Anechoic Chamber and change from table 0.8 metre to 1.5 metre (Above 18GHz the distance is 1 meter and table is 1.5 metre).
- h. Test the EUT in the lowest channel, the middle channel, the Highest channel

Note:

Both horizontal and vertical antenna polarities were tested and performed pretest to three orthogonal axis. The worst case emissions were reported

4.2.3 DEVIATION FROM TEST STANDARD

No deviation

4.2.4 TEST SETUP

(A) Radiated Emission Test-Up Frequency Below 30MHz

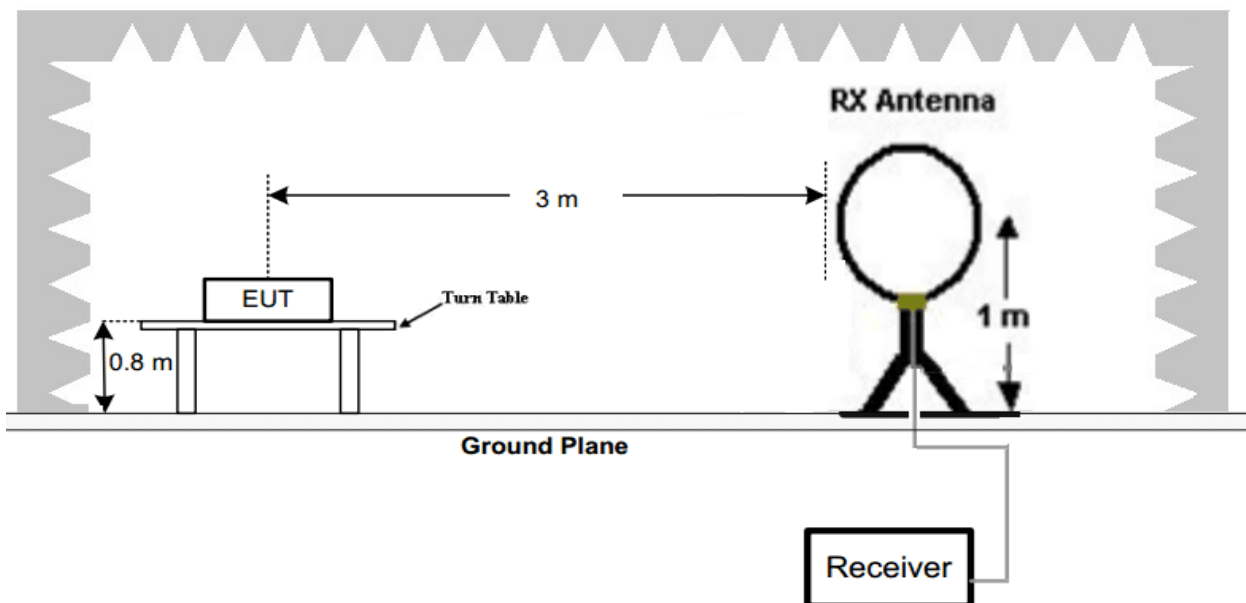

(B) Radiated Emission Test-Up Frequency 30MHz~1GHz

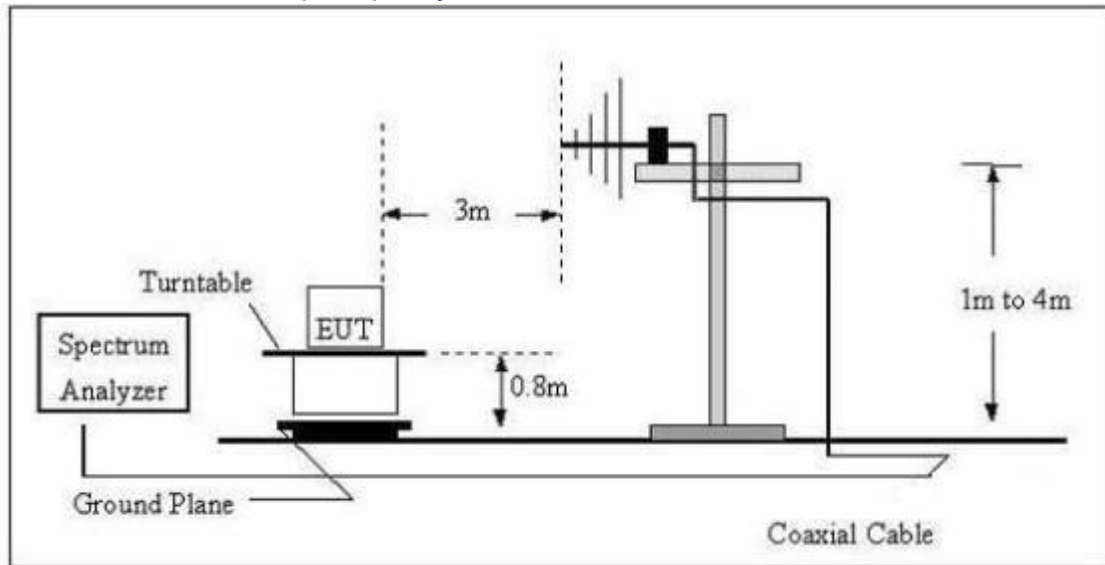

(C) Radiated Emission Test-Up Frequency Above 1GHz

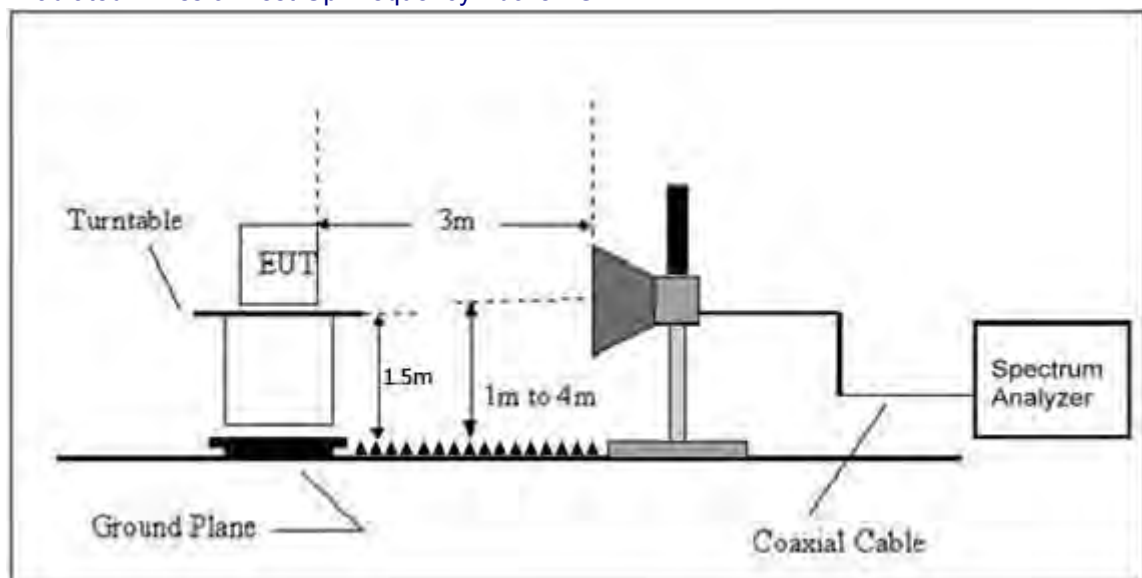

4.2.5 EUT OPERATING CONDITIONS

The EUT tested system was configured as the statements of 2.4 Unless otherwise a special operating condition is specified in the follows during the testing.

4.2.6 TEST RESULTS

Between 9KHz – 30MHz

The emission from 9 kHz to 30MHz was pre-tested and found the result was 20dB lower than the limit, and according to 15.31(o) & RSS-Gen 6.13, the test result no need to reported.

Between 30MHz – 1GHz

Temperature:	26°C	Relative Humidity:	54%
Pressure:	101 kPa	Polarization:	Horizontal
Test Voltage:	AC 120V/60Hz		

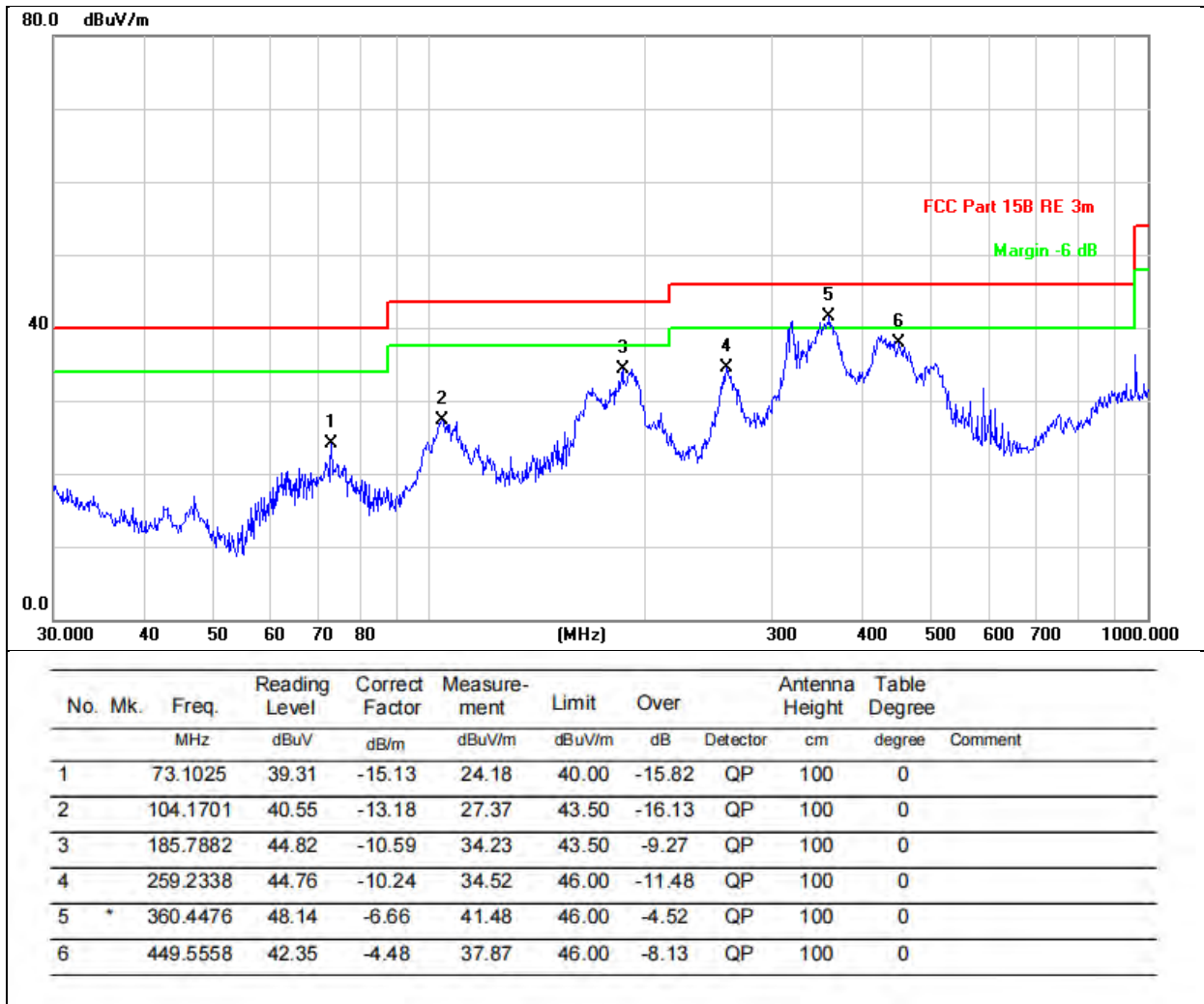

Temperature:	26°C	Relative Humidity:	54%
Pressure:	101kPa	Polarization:	Vertical
Test Voltage:	AC 120V/60Hz		

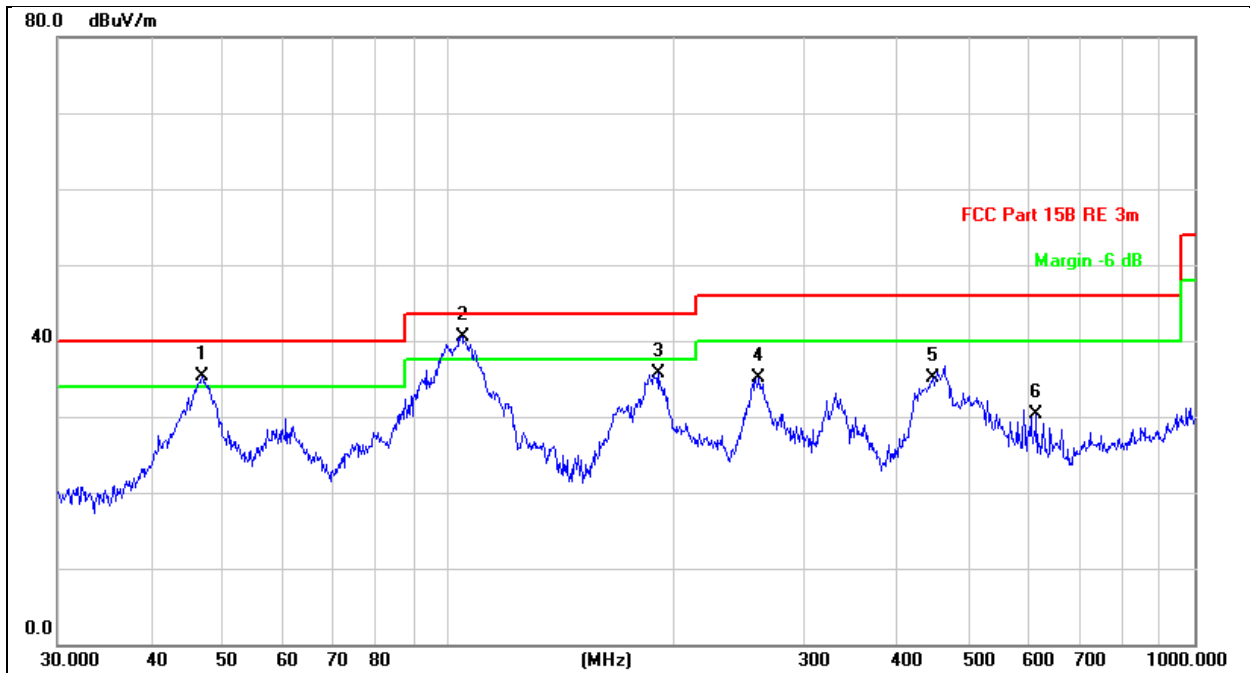

No.	Mk.	Freq. MHz	Reading Level dBuV	Correct Factor dB/m	Measure- ment dBuV/m	Limit dBuV/m	Over dB	Detector	Antenna Height cm	Table Degree	Comment
1	!	46.8303	49.04	-13.83	35.21	40.00	-4.79	QP	100	360	
2	*	104.5361	53.60	-13.13	40.47	43.50	-3.03	QP	100	360	
3		191.7450	46.13	-10.35	35.78	43.50	-7.72	QP	100	360	
4		261.0582	45.24	-10.14	35.10	46.00	-10.90	QP	100	360	
5		446.4141	39.70	-4.56	35.14	46.00	-10.86	QP	100	360	
6		614.2142	32.15	-1.79	30.36	46.00	-15.64	QP	100	360	

Remarks:

1. Final Level = Receiver Read level + Antenna Factor + Cable Loss – Preamplifier Factor
2. The emission levels of other frequencies are very lower than the limit and not show in test report.
3. The test data shows only the worst case- MIMO (802.11N-HT20 low channel)

1GHz~25GHz

802.11b-ANT1

Polar (H/V)	Frequency	Meter Reading	Pre-amplif ier	Cable Loss	Antenna Factor	Emission Level	Limits	Margin	Detect or Type
	(MHz)	(dBuV)	(dB)	(dB)	(dB)	(dBuV/m)	(dBuV/m)	(dB)	
Low Channel:2412MHz									
V	4824	56.13	30.55	5.77	24.66	56.01	74.00	-17.99	PK
V	4824	41.14	30.55	5.77	24.66	41.02	54.00	-12.98	AV
V	7236	53.37	30.33	6.32	24.55	53.91	74.00	-20.09	PK
V	7236	40.48	30.33	6.32	24.55	41.02	54.00	-12.98	AV
V	9648	51.91	30.85	7.45	24.69	53.20	74.00	-20.80	PK
V	9648	38.08	30.85	7.45	24.69	39.37	54.00	-14.63	AV
H	4824	55.12	30.55	5.77	24.66	55.00	74.00	-19.00	PK
H	4824	39.82	30.55	5.77	24.66	39.70	54.00	-14.30	AV
H	7236	54.15	30.33	6.32	24.55	54.69	74.00	-19.31	PK
H	7236	41.18	30.33	6.32	24.55	41.72	54.00	-12.28	AV
H	9648	51.94	30.85	7.45	24.69	53.23	74.00	-20.77	PK
H	9648	36.52	30.85	7.45	24.69	37.81	54.00	-16.19	AV

Polar (H/V)	Frequency	Meter Reading	Pre-amplif ier	Cable Loss	Antenna Factor	Emission Level	Limits	Margin	Detect or Type
	(MHz)	(dBuV)	(dB)	(dB)	(dB)	(dBuV/m)	(dBuV/m)	(dB)	
Middle Channel:2437MHz									
V	4874	53.84	30.55	5.77	24.66	53.72	74.00	-20.28	PK
V	4874	41.70	30.55	5.77	24.66	41.58	54.00	-12.42	AV
V	7311	52.99	30.33	6.32	24.55	53.53	74.00	-20.47	PK
V	7311	41.54	30.33	6.32	24.55	42.08	54.00	-11.92	AV
V	9748	52.63	30.85	7.45	24.69	53.92	74.00	-20.08	PK
V	9748	37.82	30.85	7.45	24.69	39.11	54.00	-14.89	AV
H	4874	54.32	30.55	5.77	24.66	54.20	74.00	-19.80	PK
H	4874	41.61	30.55	5.77	24.66	41.49	54.00	-12.51	AV
H	7311	53.90	30.33	6.32	24.55	54.44	74.00	-19.56	PK
H	7311	40.34	30.33	6.32	24.55	40.88	54.00	-13.12	AV
H	9748	51.11	30.85	7.45	24.69	52.40	74.00	-21.60	PK
H	9748	38.47	30.85	7.45	24.69	39.76	54.00	-14.24	AV

Polar (H/V)	Frequency	Meter Reading	Pre-amplifi er	Cable Loss	Antenna Factor	Emission Level	Limits	Margin	Detect or Type
	(MHz)	(dBuV)	(dB)	(dB)	(dB)	(dBuV/m)	(dBuV/m)	(dB)	
High Channel:2462MHz									
V	4924	54.31	30.55	5.77	24.66	54.19	74.00	-19.81	PK
V	4924	40.16	30.55	5.77	24.66	40.04	54.00	-13.96	AV
V	7386	54.06	30.33	6.32	24.55	54.60	74.00	-19.40	PK
V	7386	39.62	30.33	6.32	24.55	40.16	54.00	-13.84	AV
V	9848	50.38	30.85	7.45	24.69	51.67	74.00	-22.33	PK
V	9848	38.46	30.85	7.45	24.69	39.75	54.00	-14.25	AV
H	4924	55.42	30.55	5.77	24.66	55.30	74.00	-18.70	PK
H	4924	40.41	30.55	5.77	24.66	40.29	54.00	-13.71	AV
H	7386	53.69	30.33	6.32	24.55	54.23	74.00	-19.77	PK
H	7386	40.24	30.33	6.32	24.55	40.78	54.00	-13.22	AV
H	9848	51.51	30.85	7.45	24.69	52.80	74.00	-21.20	PK
H	9848	36.65	30.85	7.45	24.69	37.94	54.00	-16.06	AV

802.11g-ANT1

Polar (H/V)	Frequency	Meter Reading	Pre-ampli fier	Cable Loss	Antenna Factor	Emission Level	Limits	Margin	Detect or Type
	(MHz)	(dBuV)	(dB)	(dB)	(dB)	(dBuV/m)	(dBuV/m)	(dB)	
Low Channel:2412MHz									
V	4824	54.75	30.55	5.77	24.66	54.63	74.00	-19.37	PK
V	4824	40.71	30.55	5.77	24.66	40.59	54.00	-13.41	AV
V	7236	52.94	30.33	6.32	24.55	53.48	74.00	-20.52	PK
V	7236	39.77	30.33	6.32	24.55	40.31	54.00	-13.69	AV
V	9648	52.50	30.85	7.45	24.69	53.79	74.00	-20.21	PK
V	9648	38.61	30.85	7.45	24.69	39.90	54.00	-14.10	AV
H	4824	53.97	30.55	5.77	24.66	53.85	74.00	-20.15	PK
H	4824	40.84	30.55	5.77	24.66	40.72	54.00	-13.28	AV
H	7236	54.73	30.33	6.32	24.55	55.27	74.00	-18.73	PK
H	7236	39.70	30.33	6.32	24.55	40.24	54.00	-13.76	AV
H	9648	50.92	30.85	7.45	24.69	52.21	74.00	-21.79	PK
H	9648	38.86	30.85	7.45	24.69	40.15	54.00	-13.85	AV

Polar (H/V)	Frequency	Meter Reading	Pre-ampli fier	Cable Loss	Antenna Factor	Emission Level	Limits	Margin	Detect or Type
	(MHz)	(dBuV)	(dB)	(dB)	(dB)	(dBuV/m)	(dBuV/m)	(dB)	
Middle Channel:2437MHz									
V	4874	55.13	30.55	5.77	24.66	55.01	74.00	-18.99	PK
V	4874	39.75	30.55	5.77	24.66	39.63	54.00	-14.37	AV
V	7311	52.94	30.33	6.32	24.55	53.48	74.00	-20.52	PK
V	7311	39.78	30.33	6.32	24.55	40.32	54.00	-13.68	AV
V	9748	50.84	30.85	7.45	24.69	52.13	74.00	-21.87	PK
V	9748	39.14	30.85	7.45	24.69	40.43	54.00	-13.57	AV
H	4874	55.99	30.55	5.77	24.66	55.87	74.00	-18.13	PK
H	4874	40.01	30.55	5.77	24.66	39.89	54.00	-14.11	AV
H	7311	53.00	30.33	6.32	24.55	53.54	74.00	-20.46	PK
H	7311	39.84	30.33	6.32	24.55	40.38	54.00	-13.62	AV
H	9748	51.05	30.85	7.45	24.69	52.34	74.00	-21.66	PK
H	9748	38.37	30.85	7.45	24.69	39.66	54.00	-14.34	AV

Polar (H/V)	Frequency	Meter Reading	Pre-ampli fier	Cable Loss	Antenna Factor	Emission Level	Limits	Margin	Detect or Type
	(MHz)	(dBuV)	(dB)	(dB)	(dB)	(dBuV/m)	(dBuV/m)	(dB)	
High Channel:2462MHz									
V	4924	56.13	30.55	5.77	24.66	56.01	74.00	-17.99	PK
V	4924	41.76	30.55	5.77	24.66	41.64	54.00	-12.36	AV
V	7386	54.68	30.33	6.32	24.55	55.22	74.00	-18.78	PK
V	7386	42.01	30.33	6.32	24.55	42.55	54.00	-11.45	AV
V	9848	49.94	30.85	7.45	24.69	51.23	74.00	-22.77	PK
V	9848	37.98	30.85	7.45	24.69	39.27	54.00	-14.73	AV
H	4924	53.97	30.55	5.77	24.66	53.85	74.00	-20.15	PK
H	4924	39.87	30.55	5.77	24.66	39.75	54.00	-14.25	AV
H	7386	52.84	30.33	6.32	24.55	53.38	74.00	-20.62	PK
H	7386	38.87	30.33	6.32	24.55	39.41	54.00	-14.59	AV
H	9848	51.52	30.85	7.45	24.69	52.81	74.00	-21.19	PK
H	9848	36.46	30.85	7.45	24.69	37.75	54.00	-16.25	AV

802.11n20-ANT1

Polar (H/V)	Frequency	Meter Reading	Pre-ampl ifier	Cable Loss	Antenna Factor	Emission Level	Limits	Margin	Detect or Type
	(MHz)	(dBuV)	(dB)	(dB)	(dB)	(dBuV/m)	(dBuV/ m)	(dB)	
Low Channel:2412MHz									
V	4824	54.05	30.55	5.77	24.66	53.93	74.00	-20.07	PK
V	4824	41.29	30.55	5.77	24.66	41.17	54.00	-12.83	AV
V	7236	54.30	30.33	6.32	24.55	54.84	74.00	-19.16	PK
V	7236	41.02	30.33	6.32	24.55	41.56	54.00	-12.44	AV
V	9648	50.27	30.85	7.45	24.69	51.56	74.00	-22.44	PK
V	9648	38.01	30.85	7.45	24.69	39.30	54.00	-14.70	AV
H	4824	55.45	30.55	5.77	24.66	55.33	74.00	-18.67	PK
H	4824	40.34	30.55	5.77	24.66	40.22	54.00	-13.78	AV
H	7236	52.98	30.33	6.32	24.55	53.52	74.00	-20.48	PK
H	7236	38.86	30.33	6.32	24.55	39.40	54.00	-14.60	AV
H	9648	51.23	30.85	7.45	24.69	52.52	74.00	-21.48	PK
H	9648	38.13	30.85	7.45	24.69	39.42	54.00	-14.58	AV

Polar (H/V)	Frequency	Meter Reading	Pre-ampl ifier	Cable Loss	Antenna Factor	Emission Level	Limits	Margin	Detect or Type
	(MHz)	(dBuV)	(dB)	(dB)	(dB)	(dBuV/m)	(dBuV/ m)	(dB)	
Middle Channel:2437MHz									
V	4874	55.36	30.55	5.77	24.66	55.24	74.00	-18.76	PK
V	4874	41.75	30.55	5.77	24.66	41.63	54.00	-12.37	AV
V	7311	52.89	30.33	6.32	24.55	53.43	74.00	-20.57	PK
V	7311	40.84	30.33	6.32	24.55	41.38	54.00	-12.62	AV
V	9748	51.85	30.85	7.45	24.69	53.14	74.00	-20.86	PK
V	9748	37.88	30.85	7.45	24.69	39.17	54.00	-14.83	AV
H	4874	55.99	30.55	5.77	24.66	55.87	74.00	-18.13	PK
H	4874	41.43	30.55	5.77	24.66	41.31	54.00	-12.69	AV
H	7311	53.87	30.33	6.32	24.55	54.41	74.00	-19.59	PK
H	7311	39.19	30.33	6.32	24.55	39.73	54.00	-14.27	AV
H	9748	50.44	30.85	7.45	24.69	51.73	74.00	-22.27	PK
H	9748	39.02	30.85	7.45	24.69	40.31	54.00	-13.69	AV

Polar (H/V)	Frequency	Meter Reading	Pre-ampl ifier	Cable Loss	Antenna Factor	Emission Level	Limits	Margin	Detect or Type
	(MHz)	(dBuV)	(dB)	(dB)	(dB)	(dBuV/m)	(dBuV/ m)	(dB)	
High Channel:2462MHz									
V	4924	54.65	30.55	5.77	24.66	54.53	74.00	-19.47	PK
V	4924	40.60	30.55	5.77	24.66	40.48	54.00	-13.52	AV
V	7386	54.29	30.33	6.32	24.55	54.83	74.00	-19.17	PK
V	7386	41.78	30.33	6.32	24.55	42.32	54.00	-11.68	AV
V	9848	50.69	30.85	7.45	24.69	51.98	74.00	-22.02	PK
V	9848	39.17	30.85	7.45	24.69	40.46	54.00	-13.54	AV
H	4924	56.15	30.55	5.77	24.66	56.03	74.00	-17.97	PK
H	4924	39.66	30.55	5.77	24.66	39.54	54.00	-14.46	AV
H	7386	53.14	30.33	6.32	24.55	53.68	74.00	-20.32	PK
H	7386	39.82	30.33	6.32	24.55	40.36	54.00	-13.64	AV
H	9848	51.13	30.85	7.45	24.69	52.42	74.00	-21.58	PK
H	9848	36.83	30.85	7.45	24.69	38.12	54.00	-15.88	AV

802.11n40-ANT1

Polar (H/V)	Frequency	Meter Reading	Pre-ampl ifier	Cable Loss	Antenna Factor	Emission Level	Limits	Margin	Detect or Type
	(MHz)	(dBuV)	(dB)	(dB)	(dB)	(dBuV/m)	(dBuV/ m)	(dB)	
Low Channel:2422MHz									
V	4844	56.32	30.55	5.77	24.66	56.20	74.00	-17.80	PK
V	4844	39.84	30.55	5.77	24.66	39.72	54.00	-14.28	AV
V	7266	52.90	30.33	6.32	24.55	53.44	74.00	-20.56	PK
V	7266	40.00	30.33	6.32	24.55	40.54	54.00	-13.46	AV
V	9688	50.16	30.85	7.45	24.69	51.45	74.00	-22.55	PK
V	9688	38.71	30.85	7.45	24.69	40.00	54.00	-14.00	AV
H	4844	56.46	30.55	5.77	24.66	56.34	74.00	-17.66	PK
H	4844	39.54	30.55	5.77	24.66	39.42	54.00	-14.58	AV
H	7266	52.87	30.33	6.32	24.55	53.41	74.00	-20.59	PK
H	7266	39.89	30.33	6.32	24.55	40.43	54.00	-13.57	AV
H	9688	52.44	30.85	7.45	24.69	53.73	74.00	-20.27	PK
H	9688	38.62	30.85	7.45	24.69	39.91	54.00	-14.09	AV

Polar (H/V)	Frequency	Meter Reading	Pre-ampl ifier	Cable Loss	Antenna Factor	Emission Level	Limits	Margin	Detect or Type
	(MHz)	(dBuV)	(dB)	(dB)	(dB)	(dBuV/m)	(dBuV/ m)	(dB)	
Middle Channel:2437MHz									
V	4874	55.44	30.55	5.77	24.66	55.32	74.00	-18.68	PK
V	4874	39.60	30.55	5.77	24.66	39.48	54.00	-14.52	AV
V	7311	53.61	30.33	6.32	24.55	54.15	74.00	-19.85	PK
V	7311	40.20	30.33	6.32	24.55	40.74	54.00	-13.26	AV
V	9748	51.20	30.85	7.45	24.69	52.49	74.00	-21.51	PK
V	9748	38.22	30.85	7.45	24.69	39.51	54.00	-14.49	AV
H	4874	54.47	30.55	5.77	24.66	54.35	74.00	-19.65	PK
H	4874	41.45	30.55	5.77	24.66	41.33	54.00	-12.67	AV
H	7311	53.08	30.33	6.32	24.55	53.62	74.00	-20.38	PK
H	7311	40.56	30.33	6.32	24.55	41.10	54.00	-12.90	AV
H	9748	51.48	30.85	7.45	24.69	52.77	74.00	-21.23	PK
H	9748	38.02	30.85	7.45	24.69	39.31	54.00	-14.69	AV

Polar (H/V)	Frequency	Meter Reading	Pre-ampl ifier	Cable Loss	Antenna Factor	Emission Level	Limits	Margin	Detect or Type
	(MHz)	(dBuV)	(dB)	(dB)	(dB)	(dBuV/m)	(dBuV/ m)	(dB)	
High Channel:2452MHz									
V	4904	53.80	30.55	5.77	24.66	53.68	74.00	-20.32	PK
V	4904	40.75	30.55	5.77	24.66	40.63	54.00	-13.37	AV
V	7356	53.44	30.33	6.32	24.55	53.98	74.00	-20.02	PK
V	7356	42.15	30.33	6.32	24.55	42.69	54.00	-11.31	AV
V	9808	51.34	30.85	7.45	24.69	52.63	74.00	-21.37	PK
V	9808	38.69	30.85	7.45	24.69	39.98	54.00	-14.02	AV
H	4904	54.70	30.55	5.77	24.66	54.58	74.00	-19.42	PK
H	4904	40.72	30.55	5.77	24.66	40.60	54.00	-13.40	AV
H	7356	54.14	30.33	6.32	24.55	54.68	74.00	-19.32	PK
H	7356	38.80	30.33	6.32	24.55	39.34	54.00	-14.66	AV
H	9808	52.14	30.85	7.45	24.69	53.43	74.00	-20.57	PK
H	9808	38.41	30.85	7.45	24.69	39.70	54.00	-14.30	AV

802.11b-ANT2

Polar (H/V)	Frequency	Meter Reading	Pre-ampl ifier	Cable Loss	Antenna Factor	Emission Level	Limits	Margin	Detect or Type
	(MHz)	(dBuV)	(dB)	(dB)	(dB)	(dBuV/m)	(dBuV/ m)	(dB)	
Low Channel:2412MHz									
V	4824	55.12	30.55	5.77	24.66	55.00	74.00	-19.00	PK
V	4824	42.23	30.55	5.77	24.66	42.11	54.00	-11.89	AV
V	7236	52.90	30.33	6.32	24.55	53.44	74.00	-20.56	PK
V	7236	40.98	30.33	6.32	24.55	41.52	54.00	-12.48	AV
V	9648	51.91	30.85	7.45	24.69	53.20	74.00	-20.80	PK
V	9648	38.00	30.85	7.45	24.69	39.29	54.00	-14.71	AV
H	4824	56.52	30.55	5.77	24.66	56.40	74.00	-17.60	PK
H	4824	39.43	30.55	5.77	24.66	39.31	54.00	-14.69	AV
H	7236	54.08	30.33	6.32	24.55	54.62	74.00	-19.38	PK
H	7236	39.60	30.33	6.32	24.55	40.14	54.00	-13.86	AV
H	9648	50.87	30.85	7.45	24.69	52.16	74.00	-21.84	PK
H	9648	36.66	30.85	7.45	24.69	37.95	54.00	-16.05	AV

Polar (H/V)	Frequency	Meter Reading	Pre-ampl ifier	Cable Loss	Antenna Factor	Emission Level	Limits	Margin	Detect or Type
	(MHz)	(dBuV)	(dB)	(dB)	(dB)	(dBuV/m)	(dBuV/ m)	(dB)	
Middle Channel:2437MHz									
V	4874	54.10	30.55	5.77	24.66	53.98	74.00	-20.02	PK
V	4874	42.02	30.55	5.77	24.66	41.90	54.00	-12.10	AV
V	7311	53.24	30.33	6.32	24.55	53.78	74.00	-20.22	PK
V	7311	39.72	30.33	6.32	24.55	40.26	54.00	-13.74	AV
V	9748	50.98	30.85	7.45	24.69	52.27	74.00	-21.73	PK
V	9748	38.77	30.85	7.45	24.69	40.06	54.00	-13.94	AV
H	4874	56.50	30.55	5.77	24.66	56.38	74.00	-17.62	PK
H	4874	41.78	30.55	5.77	24.66	41.66	54.00	-12.34	AV
H	7311	54.27	30.33	6.32	24.55	54.81	74.00	-19.19	PK
H	7311	40.11	30.33	6.32	24.55	40.65	54.00	-13.35	AV
H	9748	51.46	30.85	7.45	24.69	52.75	74.00	-21.25	PK
H	9748	36.96	30.85	7.45	24.69	38.25	54.00	-15.75	AV

Polar (H/V)	Frequency	Meter Reading	Pre-ampl ifier	Cable Loss	Antenna Factor	Emission Level	Limits	Margin	Detect or Type
	(MHz)	(dBuV)	(dB)	(dB)	(dB)	(dBuV/m)	(dBuV/ m)	(dB)	
High Channel:2462MHz									
V	4924	54.13	30.55	5.77	24.66	54.01	74.00	-19.99	PK
V	4924	41.02	30.55	5.77	24.66	40.90	54.00	-13.10	AV
V	7386	54.30	30.33	6.32	24.55	54.84	74.00	-19.16	PK
V	7386	41.77	30.33	6.32	24.55	42.31	54.00	-11.69	AV
V	9848	52.61	30.85	7.45	24.69	53.90	74.00	-20.10	PK
V	9848	36.89	30.85	7.45	24.69	38.18	54.00	-15.82	AV
H	4924	54.34	30.55	5.77	24.66	54.22	74.00	-19.78	PK
H	4924	41.42	30.55	5.77	24.66	41.30	54.00	-12.70	AV
H	7386	53.30	30.33	6.32	24.55	53.84	74.00	-20.16	PK
H	7386	40.69	30.33	6.32	24.55	41.23	54.00	-12.77	AV
H	9848	50.21	30.85	7.45	24.69	51.50	74.00	-22.50	PK
H	9848	38.76	30.85	7.45	24.69	40.05	54.00	-13.95	AV

802.11g-ANT2

Polar (H/V)	Frequency	Meter Reading	Pre-ampl ifier	Cable Loss	Antenna Factor	Emission Level	Limits	Margin	Detect or Type
	(MHz)	(dBuV)	(dB)	(dB)	(dB)	(dBuV/m)	(dBuV/ m)	(dB)	
Low Channel:2412MHz									
V	4824	56.14	30.55	5.77	24.66	56.02	74.00	-17.98	PK
V	4824	39.57	30.55	5.77	24.66	39.45	54.00	-14.55	AV
V	7236	53.14	30.33	6.32	24.55	53.68	74.00	-20.32	PK
V	7236	39.27	30.33	6.32	24.55	39.81	54.00	-14.19	AV
V	9648	52.39	30.85	7.45	24.69	53.68	74.00	-20.32	PK
V	9648	37.59	30.85	7.45	24.69	38.88	54.00	-15.12	AV
H	4824	56.01	30.55	5.77	24.66	55.89	74.00	-18.11	PK
H	4824	41.48	30.55	5.77	24.66	41.36	54.00	-12.64	AV
H	7236	53.51	30.33	6.32	24.55	54.05	74.00	-19.95	PK
H	7236	40.16	30.33	6.32	24.55	40.70	54.00	-13.30	AV
H	9648	50.42	30.85	7.45	24.69	51.71	74.00	-22.29	PK
H	9648	38.48	30.85	7.45	24.69	39.77	54.00	-14.23	AV

Polar (H/V)	Frequency	Meter Reading	Pre-ampl ifier	Cable Loss	Antenna Factor	Emission Level	Limits	Margin	Detect or Type
	(MHz)	(dBuV)	(dB)	(dB)	(dB)	(dBuV/m)	(dBuV/ m)	(dB)	
Middle Channel:2437MHz									
V	4874	56.12	30.55	5.77	24.66	56.00	74.00	-18.00	PK
V	4874	40.35	30.55	5.77	24.66	40.23	54.00	-13.77	AV
V	7311	54.01	30.33	6.32	24.55	54.55	74.00	-19.45	PK
V	7311	40.74	30.33	6.32	24.55	41.28	54.00	-12.72	AV
V	9748	50.93	30.85	7.45	24.69	52.22	74.00	-21.78	PK
V	9748	38.13	30.85	7.45	24.69	39.42	54.00	-14.58	AV
H	4874	54.26	30.55	5.77	24.66	54.14	74.00	-19.86	PK
H	4874	40.49	30.55	5.77	24.66	40.37	54.00	-13.63	AV
H	7311	54.07	30.33	6.32	24.55	54.61	74.00	-19.39	PK
H	7311	41.69	30.33	6.32	24.55	42.23	54.00	-11.77	AV
H	9748	50.57	30.85	7.45	24.69	51.86	74.00	-22.14	PK
H	9748	37.31	30.85	7.45	24.69	38.60	54.00	-15.40	AV

Polar (H/V)	Frequency	Meter Reading	Pre-ampl ifier	Cable Loss	Antenna Factor	Emission Level	Limits	Margin	Detect or Type
	(MHz)	(dBuV)	(dB)	(dB)	(dB)	(dBuV/m)	(dBuV/ m)	(dB)	
High Channel:2462MHz									
V	4924	54.02	30.55	5.77	24.66	53.90	74.00	-20.10	PK
V	4924	39.52	30.55	5.77	24.66	39.40	54.00	-14.60	AV
V	7386	54.53	30.33	6.32	24.55	55.07	74.00	-18.93	PK
V	7386	39.90	30.33	6.32	24.55	40.44	54.00	-13.56	AV
V	9848	51.60	30.85	7.45	24.69	52.89	74.00	-21.11	PK
V	9848	38.68	30.85	7.45	24.69	39.97	54.00	-14.03	AV
H	4924	55.46	30.55	5.77	24.66	55.34	74.00	-18.66	PK
H	4924	41.49	30.55	5.77	24.66	41.37	54.00	-12.63	AV
H	7386	53.38	30.33	6.32	24.55	53.92	74.00	-20.08	PK
H	7386	40.88	30.33	6.32	24.55	41.42	54.00	-12.58	AV
H	9848	51.17	30.85	7.45	24.69	52.46	74.00	-21.54	PK
H	9848	38.88	30.85	7.45	24.69	40.17	54.00	-13.83	AV

802.11n-ANT2

Polar (H/V)	Frequency	Meter Reading	Pre-ampl ifier	Cable Loss	Antenna Factor	Emission Level	Limits	Margin	Detect or Type
	(MHz)	(dBuV)	(dB)	(dB)	(dB)	(dBuV/m)	(dBuV/ m)	(dB)	
Low Channel:2412MHz									
V	4824	54.98	30.55	5.77	24.66	54.86	74.00	-19.14	PK
V	4824	40.51	30.55	5.77	24.66	40.39	54.00	-13.61	AV
V	7236	53.13	30.33	6.32	24.55	53.67	74.00	-20.33	PK
V	7236	40.92	30.33	6.32	24.55	41.46	54.00	-12.54	AV
V	9648	51.49	30.85	7.45	24.69	52.78	74.00	-21.22	PK
V	9648	37.78	30.85	7.45	24.69	39.07	54.00	-14.93	AV
H	4824	56.59	30.55	5.77	24.66	56.47	74.00	-17.53	PK
H	4824	40.14	30.55	5.77	24.66	40.02	54.00	-13.98	AV
H	7236	52.87	30.33	6.32	24.55	53.41	74.00	-20.59	PK
H	7236	39.26	30.33	6.32	24.55	39.80	54.00	-14.20	AV
H	9648	51.67	30.85	7.45	24.69	52.96	74.00	-21.04	PK
H	9648	36.96	30.85	7.45	24.69	38.25	54.00	-15.75	AV

Polar (H/V)	Frequency	Meter Reading	Pre-ampl ifier	Cable Loss	Antenna Factor	Emission Level	Limits	Margin	Detect or Type
	(MHz)	(dBuV)	(dB)	(dB)	(dB)	(dBuV/m)	(dBuV/ m)	(dB)	
Middle Channel:2437MHz									
V	4874	53.82	30.55	5.77	24.66	53.70	74.00	-20.30	PK
V	4874	41.04	30.55	5.77	24.66	40.92	54.00	-13.08	AV
V	7311	54.39	30.33	6.32	24.55	54.93	74.00	-19.07	PK
V	7311	40.23	30.33	6.32	24.55	40.77	54.00	-13.23	AV
V	9748	52.50	30.85	7.45	24.69	53.79	74.00	-20.21	PK
V	9748	37.69	30.85	7.45	24.69	38.98	54.00	-15.02	AV
H	4874	54.37	30.55	5.77	24.66	54.25	74.00	-19.75	PK
H	4874	40.38	30.55	5.77	24.66	40.26	54.00	-13.74	AV
H	7311	53.66	30.33	6.32	24.55	54.20	74.00	-19.80	PK
H	7311	40.74	30.33	6.32	24.55	41.28	54.00	-12.72	AV
H	9748	52.51	30.85	7.45	24.69	53.80	74.00	-20.20	PK
H	9748	38.24	30.85	7.45	24.69	39.53	54.00	-14.47	AV

Polar (H/V)	Frequency	Meter Reading	Pre-ampl ifier	Cable Loss	Antenna Factor	Emission Level	Limits	Margin	Detect or Type
	(MHz)	(dBuV)	(dB)	(dB)	(dB)	(dBuV/m)	(dBuV/ m)	(dB)	
High Channel:2462MHz									
V	4924	55.47	30.55	5.77	24.66	55.35	74.00	-18.65	PK
V	4924	39.94	30.55	5.77	24.66	39.82	54.00	-14.18	AV
V	7386	53.92	30.33	6.32	24.55	54.46	74.00	-19.54	PK
V	7386	41.00	30.33	6.32	24.55	41.54	54.00	-12.46	AV
V	9848	49.91	30.85	7.45	24.69	51.20	74.00	-22.80	PK
V	9848	38.32	30.85	7.45	24.69	39.61	54.00	-14.39	AV
H	4924	56.31	30.55	5.77	24.66	56.19	74.00	-17.81	PK
H	4924	39.24	30.55	5.77	24.66	39.12	54.00	-14.88	AV
H	7386	53.71	30.33	6.32	24.55	54.25	74.00	-19.75	PK
H	7386	39.11	30.33	6.32	24.55	39.65	54.00	-14.35	AV
H	9848	50.60	30.85	7.45	24.69	51.89	74.00	-22.11	PK
H	9848	38.62	30.85	7.45	24.69	39.91	54.00	-14.09	AV

802.11n40-ANT2

Polar (H/V)	Frequency	Meter Reading	Pre-ampl ifier	Cable Loss	Antenna Factor	Emission Level	Limits	Margin	Detect or Type
	(MHz)	(dBuV)	(dB)	(dB)	(dB)	(dBuV/m)	(dBuV/ m)	(dB)	
Low Channel:2422MHz									
V	4844	55.16	30.55	5.77	24.66	55.04	74.00	-18.96	PK
V	4844	40.79	30.55	5.77	24.66	40.67	54.00	-13.33	AV
V	7266	53.10	30.33	6.32	24.55	53.64	74.00	-20.36	PK
V	7266	42.08	30.33	6.32	24.55	42.62	54.00	-11.38	AV
V	9688	50.64	30.85	7.45	24.69	51.93	74.00	-22.07	PK
V	9688	36.72	30.85	7.45	24.69	38.01	54.00	-15.99	AV
H	4844	54.04	30.55	5.77	24.66	53.92	74.00	-20.08	PK
H	4844	40.98	30.55	5.77	24.66	40.86	54.00	-13.14	AV
H	7266	54.22	30.33	6.32	24.55	54.76	74.00	-19.24	PK
H	7266	39.73	30.33	6.32	24.55	40.27	54.00	-13.73	AV
H	9688	52.47	30.85	7.45	24.69	53.76	74.00	-20.24	PK
H	9688	37.66	30.85	7.45	24.69	38.95	54.00	-15.05	AV

Polar (H/V)	Frequency	Meter Reading	Pre-ampl ifier	Cable Loss	Antenna Factor	Emission Level	Limits	Margin	Detect or Type
	(MHz)	(dBuV)	(dB)	(dB)	(dB)	(dBuV/m)	(dBuV/ m)	(dB)	
Middle Channel:2437MHz									
V	4874	56.36	30.55	5.77	24.66	56.24	74.00	-17.76	PK
V	4874	41.21	30.55	5.77	24.66	41.09	54.00	-12.91	AV
V	7311	54.52	30.33	6.32	24.55	55.06	74.00	-18.94	PK
V	7311	41.83	30.33	6.32	24.55	42.37	54.00	-11.63	AV
V	9748	52.07	30.85	7.45	24.69	53.36	74.00	-20.64	PK
V	9748	37.94	30.85	7.45	24.69	39.23	54.00	-14.77	AV
H	4874	55.15	30.55	5.77	24.66	55.03	74.00	-18.97	PK
H	4874	42.11	30.55	5.77	24.66	41.99	54.00	-12.01	AV
H	7311	53.28	30.33	6.32	24.55	53.82	74.00	-20.18	PK
H	7311	40.01	30.33	6.32	24.55	40.55	54.00	-13.45	AV
H	9748	52.12	30.85	7.45	24.69	53.41	74.00	-20.59	PK
H	9748	36.29	30.85	7.45	24.69	37.58	54.00	-16.42	AV

Polar (H/V)	Frequency	Meter Reading	Pre-ampl ifier	Cable Loss	Antenna Factor	Emission Level	Limits	Margin	Detect or Type
	(MHz)	(dBuV)	(dB)	(dB)	(dB)	(dBuV/m)	(dBuV/ m)	(dB)	
High Channel:2452MHz									
V	4904	54.53	30.55	5.77	24.66	54.41	74.00	-19.59	PK
V	4904	39.39	30.55	5.77	24.66	39.27	54.00	-14.73	AV
V	7356	54.38	30.33	6.32	24.55	54.92	74.00	-19.08	PK
V	7356	39.44	30.33	6.32	24.55	39.98	54.00	-14.02	AV
V	9808	49.95	30.85	7.45	24.69	51.24	74.00	-22.76	PK
V	9808	38.83	30.85	7.45	24.69	40.12	54.00	-13.88	AV
H	4904	55.94	30.55	5.77	24.66	55.82	74.00	-18.18	PK
H	4904	39.50	30.55	5.77	24.66	39.38	54.00	-14.62	AV
H	7356	53.74	30.33	6.32	24.55	54.28	74.00	-19.72	PK
H	7356	40.91	30.33	6.32	24.55	41.45	54.00	-12.55	AV
H	9808	49.91	30.85	7.45	24.69	51.20	74.00	-22.80	PK
H	9808	37.37	30.85	7.45	24.69	38.66	54.00	-15.34	AV

MIMO-802.11n

Polar (H/V)	Frequency	Meter Reading	Pre-ampl ifier	Cable Loss	Antenna Factor	Emission Level	Limits	Margin	Detect or Type
	(MHz)	(dBuV)	(dB)	(dB)	(dB)	(dBuV/m)	(dBuV/ m)	(dB)	
Low Channel:2412MHz									
V	4824	55.59	30.55	5.77	24.66	55.47	74.00	-18.53	PK
V	4824	40.77	30.55	5.77	24.66	40.65	54.00	-13.35	AV
V	7236	54.71	30.33	6.32	24.55	55.25	74.00	-18.75	PK
V	7236	39.30	30.33	6.32	24.55	39.84	54.00	-14.16	AV
V	9648	51.73	30.85	7.45	24.69	53.02	74.00	-20.98	PK
V	9648	36.28	30.85	7.45	24.69	37.57	54.00	-16.43	AV
H	4824	56.06	30.55	5.77	24.66	55.94	74.00	-18.06	PK
H	4824	41.74	30.55	5.77	24.66	41.62	54.00	-12.38	AV
H	7236	54.45	30.33	6.32	24.55	54.99	74.00	-19.01	PK
H	7236	39.04	30.33	6.32	24.55	39.58	54.00	-14.42	AV
H	9648	50.77	30.85	7.45	24.69	52.06	74.00	-21.94	PK
H	9648	37.91	30.85	7.45	24.69	39.20	54.00	-14.80	AV

Polar (H/V)	Frequency	Meter Reading	Pre-ampl ifier	Cable Loss	Antenna Factor	Emission Level	Limits	Margin	Detect or Type
	(MHz)	(dBuV)	(dB)	(dB)	(dB)	(dBuV/m)	(dBuV/ m)	(dB)	
Middle Channel:2437MHz									
V	4874	56.09	30.55	5.77	24.66	55.97	74.00	-18.03	PK
V	4874	40.31	30.55	5.77	24.66	40.19	54.00	-13.81	AV
V	7311	53.24	30.33	6.32	24.55	53.78	74.00	-20.22	PK
V	7311	40.20	30.33	6.32	24.55	40.74	54.00	-13.26	AV
V	9748	50.61	30.85	7.45	24.69	51.90	74.00	-22.10	PK
V	9748	36.79	30.85	7.45	24.69	38.08	54.00	-15.92	AV
H	4874	54.05	30.55	5.77	24.66	53.93	74.00	-20.07	PK
H	4874	41.16	30.55	5.77	24.66	41.04	54.00	-12.96	AV
H	7311	52.90	30.33	6.32	24.55	53.44	74.00	-20.56	PK
H	7311	41.00	30.33	6.32	24.55	41.54	54.00	-12.46	AV
H	9748	52.63	30.85	7.45	24.69	53.92	74.00	-20.08	PK
H	9748	36.95	30.85	7.45	24.69	38.24	54.00	-15.76	AV

Polar (H/V)	Frequency	Meter Reading	Pre-ampl ifier	Cable Loss	Antenna Factor	Emission Level	Limits	Margin	Detect or Type
	(MHz)	(dBuV)	(dB)	(dB)	(dB)	(dBuV/m)	(dBuV/ m)	(dB)	
High Channel:2462MHz									
V	4924	56.59	30.55	5.77	24.66	56.47	74.00	-17.53	PK
V	4924	39.63	30.55	5.77	24.66	39.51	54.00	-14.49	AV
V	7386	52.79	30.33	6.32	24.55	53.33	74.00	-20.67	PK
V	7386	40.96	30.33	6.32	24.55	41.50	54.00	-12.50	AV
V	9848	51.40	30.85	7.45	24.69	52.69	74.00	-21.31	PK
V	9848	36.70	30.85	7.45	24.69	37.99	54.00	-16.01	AV
H	4924	54.50	30.55	5.77	24.66	54.38	74.00	-19.62	PK
H	4924	42.19	30.55	5.77	24.66	42.07	54.00	-11.93	AV
H	7386	54.73	30.33	6.32	24.55	55.27	74.00	-18.73	PK
H	7386	40.71	30.33	6.32	24.55	41.25	54.00	-12.75	AV
H	9848	50.64	30.85	7.45	24.69	51.93	74.00	-22.07	PK
H	9848	37.28	30.85	7.45	24.69	38.57	54.00	-15.43	AV

MIMO-802.11n40

Polar (H/V)	Frequency	Meter Reading	Pre-ampl ifier	Cable Loss	Antenna Factor	Emission Level	Limits	Margin	Detect or Type
	(MHz)	(dBuV)	(dB)	(dB)	(dB)	(dBuV/m)	(dBuV/ m)	(dB)	
Low Channel:2422MHz									
V	4844	54.53	30.55	5.77	24.66	54.41	74.00	-19.59	PK
V	4844	40.37	30.55	5.77	24.66	40.25	54.00	-13.75	AV
V	7266	53.01	30.33	6.32	24.55	53.55	74.00	-20.45	PK
V	7266	42.21	30.33	6.32	24.55	42.75	54.00	-11.25	AV
V	9688	52.58	30.85	7.45	24.69	53.87	74.00	-20.13	PK
V	9688	36.91	30.85	7.45	24.69	38.20	54.00	-15.80	AV
H	4844	55.33	30.55	5.77	24.66	55.21	74.00	-18.79	PK
H	4844	41.30	30.55	5.77	24.66	41.18	54.00	-12.82	AV
H	7266	53.76	30.33	6.32	24.55	54.30	74.00	-19.70	PK
H	7266	40.36	30.33	6.32	24.55	40.90	54.00	-13.10	AV
H	9688	50.84	30.85	7.45	24.69	52.13	74.00	-21.87	PK
H	9688	36.65	30.85	7.45	24.69	37.94	54.00	-16.06	AV

Polar (H/V)	Frequency	Meter Reading	Pre-ampl ifier	Cable Loss	Antenna Factor	Emission Level	Limits	Margin	Detect or Type
	(MHz)	(dBuV)	(dB)	(dB)	(dB)	(dBuV/m)	(dBuV/ m)	(dB)	
Middle Channel:2437MHz									
V	4874	53.80	30.55	5.77	24.66	53.68	74.00	-20.32	PK
V	4874	41.34	30.55	5.77	24.66	41.22	54.00	-12.78	AV
V	7311	52.89	30.33	6.32	24.55	53.43	74.00	-20.57	PK
V	7311	41.82	30.33	6.32	24.55	42.36	54.00	-11.64	AV
V	9748	51.44	30.85	7.45	24.69	52.73	74.00	-21.27	PK
V	9748	36.74	30.85	7.45	24.69	38.03	54.00	-15.97	AV
H	4874	54.87	30.55	5.77	24.66	54.75	74.00	-19.25	PK
H	4874	39.59	30.55	5.77	24.66	39.47	54.00	-14.53	AV
H	7311	54.54	30.33	6.32	24.55	55.08	74.00	-18.92	PK
H	7311	41.24	30.33	6.32	24.55	41.78	54.00	-12.22	AV
H	9748	51.90	30.85	7.45	24.69	53.19	74.00	-20.81	PK
H	9748	37.65	30.85	7.45	24.69	38.94	54.00	-15.06	AV

Polar (H/V)	Frequency	Meter Reading	Pre-ampl ifier	Cable Loss	Antenna Factor	Emission Level	Limits	Margin	Detect or Type
	(MHz)	(dBuV)	(dB)	(dB)	(dB)	(dBuV/m)	(dBuV/ m)	(dB)	
High Channel:2452MHz									
V	4904	55.19	30.55	5.77	24.66	55.07	74.00	-18.93	PK
V	4904	41.32	30.55	5.77	24.66	41.20	54.00	-12.80	AV
V	7356	54.29	30.33	6.32	24.55	54.83	74.00	-19.17	PK
V	7356	41.22	30.33	6.32	24.55	41.76	54.00	-12.24	AV
V	9808	52.37	30.85	7.45	24.69	53.66	74.00	-20.34	PK
V	9808	37.43	30.85	7.45	24.69	38.72	54.00	-15.28	AV
H	4904	55.78	30.55	5.77	24.66	55.66	74.00	-18.34	PK
H	4904	40.77	30.55	5.77	24.66	40.65	54.00	-13.35	AV
H	7356	54.57	30.33	6.32	24.55	55.11	74.00	-18.89	PK
H	7356	39.63	30.33	6.32	24.55	40.17	54.00	-13.83	AV
H	9808	52.48	30.85	7.45	24.69	53.77	74.00	-20.23	PK
H	9808	36.26	30.85	7.45	24.69	37.55	54.00	-16.45	AV

5. RADIATED BAND EMISSION MEASUREMENT

5.1 TEST REQUIREMENT:

Test Requirement:	FCC Part15 C Section 15.209 and 15.205				
Test Method:	ANSI C63.10: 2013				
Test Frequency Range:	All of the restrict bands were tested, only the worst band's (2310MHz to 2500MHz) data was showed.				
Test site:	Measurement Distance: 3m				
Receiver setup:	Frequency	Detector	RBW	VBW	Value
	Above 1GHz	Peak	1MHz	3MHz	Peak
		Average	1MHz	3MHz	Average

LIMITS OF RADIATED EMISSION MEASUREMENT (Above 1000MHz)

FREQUENCY (MHz)	Class B (dBuV/m) (at 3M)	
	PEAK	AVERAGE
Above 1000	74	54

Notes:

- (1) The limit for radiated test was performed according to FCC PART 15C.
- (2) The tighter limit applies at the band edges.
- (3) Emission level (dBuV/m)=20log Emission level (uV/m).

5.2 TEST PROCEDURE

Above 1GHz test procedure as below:

- a. 1. The EUT was placed on the top of a rotating table 1.5 meters above the ground at a 3 meter camber. The table was rotated 360 degrees to determine the position of the highest radiation.
- b. The EUT was set 3 meters away from the interference-receiving antenna, which was mounted on the top of a variable-height antenna tower.
- c. The antenna height is varied from one meter to four meters above the ground to determine the maximum value of the field strength. Both horizontal and vertical polarizations of the antenna are set to make the measurement.
- d. For each suspected emission, the EUT was arranged to its worst case and then the antenna was tuned to heights from 1 meter to 4 meters and the rota table was turned from 0 degrees to 360 degrees to find the maximum reading.
- e. The test-receiver system was set to Peak Detect Function and Specified Bandwidth with Maximum Hold Mode.
- f. If the emission level of the EUT in peak mode was 10dB lower than the limit specified, then testing could bestopped and the peak values of the EUT would be reported. Otherwise the emissions that did not have 10dBmargin would be re-tested one by one using peak, quasi-peak or average method as specified and then reportedin a data sheet.
- g. Test the EUT in the lowest channel,the Highest channel

Note:

Both horizontal and vertical antenna polarities were tested and performed pretest to three orthogonal axis. The worst case emissions were reported

5.3 DEVIATION FROM TEST STANDARD

No deviation

5.4 TEST SETUP

Radiated Emission Test-Up Frequency Above 1GHz

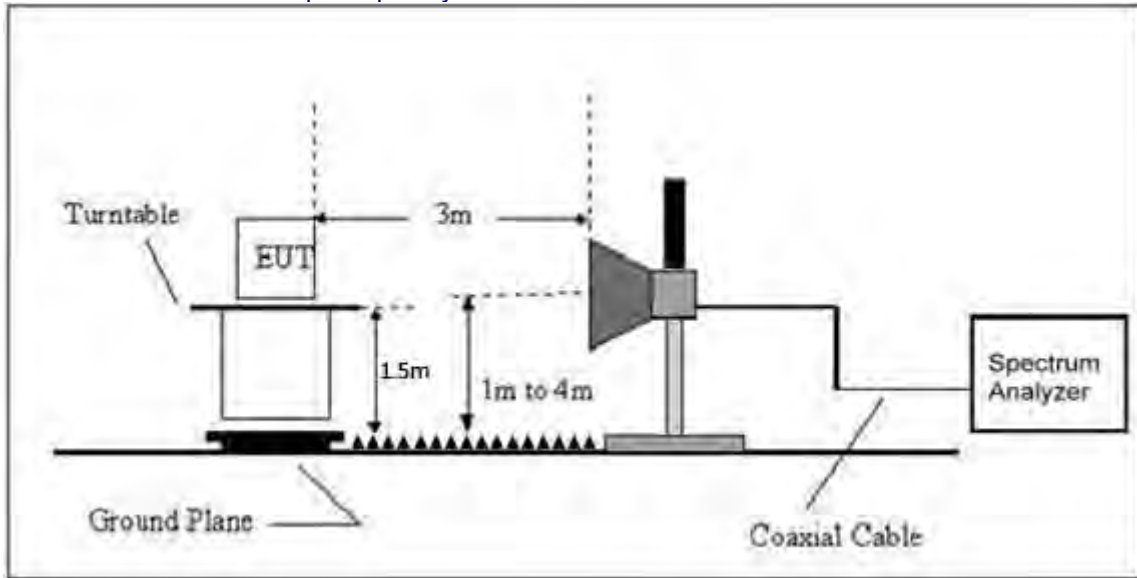

5.5 EUT OPERATING CONDITIONS

The EUT tested system was configured as the statements of 2.3 Unless otherwise a special operating condition is specified in the follows during the testing.

5.6 TEST RESULT

ANT1-802.11b

Polar (H/V)	Frequency (MHz)	Meter Reading (dBuV)	Pre-amplifier (dB)	Cable Loss (dB)	Antenna Factor (dB/m)	Emission level (dBuV/m)	Limit (dBuV/m)	Margin (dBuV/m)	Detect or Type	Result
Low Channel 2412MHz										
H	2390.00	51.15	30.22	4.85	23.98	49.76	74	-24.24	PK	PASS
H	2390.00	40.17	30.22	4.85	23.98	38.78	54	-15.22	AV	PASS
H	2400.00	54.17	30.22	4.85	23.98	52.78	74	-21.22	PK	PASS
H	2400.00	37.61	30.22	4.85	23.98	36.22	54	-17.78	AV	PASS
V	2390.00	53.41	30.22	4.85	23.98	52.02	74	-21.98	PK	PASS
V	2390.00	39.43	30.22	4.85	23.98	38.04	54	-15.96	AV	PASS
V	2400.00	54.56	30.22	4.85	23.98	53.17	74	-20.83	PK	PASS
V	2400.00	38.67	30.22	4.85	23.98	37.28	54	-16.72	AV	PASS
High Channel 2462MHz										
H	2483.50	50.89	30.22	4.85	23.98	49.50	74	-24.50	PK	PASS
H	2483.50	37.78	30.22	4.85	23.98	36.39	54	-17.61	AV	PASS
H	2500.00	51.84	30.22	4.85	23.98	50.45	74	-23.55	PK	PASS
H	2500.00	38.72	30.22	4.85	23.98	37.33	54	-16.67	AV	PASS
V	2483.50	50.99	30.22	4.85	23.98	49.60	74	-24.40	PK	PASS
V	2483.50	39.18	30.22	4.85	23.98	37.79	54	-16.21	AV	PASS
V	2500.00	54.36	30.22	4.85	23.98	52.97	74	-21.03	PK	PASS
V	2500.00	39.05	30.22	4.85	23.98	37.66	54	-16.34	AV	PASS

ANT1-802.11g

Polar (H/V)	Frequency (MHz)	Meter Reading (dBuV)	Pre-amplifier (dB)	Cable Loss (dB)	Antenna Factor (dB/m)	Emission level (dBuV/m)	Limit (dBuV/m)	Margin (dBuV/m)	Detect or Type	Result
Low Channel 2412MHz										
H	2390.00	52.61	30.22	4.85	23.98	51.22	74	-22.78	PK	PASS
H	2390.00	39.87	30.22	4.85	23.98	38.48	54	-15.52	AV	PASS
H	2400.00	51.87	30.22	4.85	23.98	50.48	74	-23.52	PK	PASS
H	2400.00	37.86	30.22	4.85	23.98	36.47	54	-17.53	AV	PASS
V	2390.00	52.96	30.22	4.85	23.98	51.57	74	-22.43	PK	PASS
V	2390.00	39.63	30.22	4.85	23.98	38.24	54	-15.76	AV	PASS
V	2400.00	54.43	30.22	4.85	23.98	53.04	74	-20.96	PK	PASS
V	2400.00	38.63	30.22	4.85	23.98	37.24	54	-16.76	AV	PASS
High Channel 2462MHz										
H	2483.50	52.91	30.22	4.85	23.98	51.52	74	-22.48	PK	PASS
H	2483.50	39.35	30.22	4.85	23.98	37.96	54	-16.04	AV	PASS
H	2500.00	53.12	30.22	4.85	23.98	51.73	74	-22.27	PK	PASS
H	2500.00	38.12	30.22	4.85	23.98	36.73	54	-17.27	AV	PASS
V	2483.50	52.22	30.22	4.85	23.98	50.83	74	-23.17	PK	PASS
V	2483.50	40.11	30.22	4.85	23.98	38.72	54	-15.28	AV	PASS
V	2500.00	53.52	30.22	4.85	23.98	52.13	74	-21.87	PK	PASS
V	2500.00	36.24	30.22	4.85	23.98	34.85	54	-19.15	AV	PASS

ANT1-802.11n20

Polar (H/V)	Frequency (MHz)	Meter Reading (dBuV)	Pre-amplifier (dB)	Cable Loss (dB)	Antenna Factor (dB/m)	Emission level (dBuV/m)	Limit (dBuV/m)	Margin (dBuV/m)	Detect or Type	Result
Low Channel 2412MHz										
H	2390.00	53.53	30.22	4.85	23.98	52.14	74	-21.86	PK	PASS
H	2390.00	39.77	30.22	4.85	23.98	38.38	54	-15.62	AV	PASS
H	2400.00	51.97	30.22	4.85	23.98	50.58	74	-23.42	PK	PASS
H	2400.00	38.59	30.22	4.85	23.98	37.20	54	-16.80	AV	PASS
V	2390.00	51.85	30.22	4.85	23.98	50.46	74	-23.54	PK	PASS
V	2390.00	37.48	30.22	4.85	23.98	36.09	54	-17.91	AV	PASS

V	2400.00	54.53	30.22	4.85	23.98	53.14	74	-20.86	PK	PASS
V	2400.00	37.68	30.22	4.85	23.98	36.29	54	-17.71	AV	PASS
High Channel 2462MHz										
H	2483.50	51.91	30.22	4.85	23.98	50.52	74	-23.48	PK	PASS
H	2483.50	37.26	30.22	4.85	23.98	35.87	54	-18.13	AV	PASS
H	2500.00	54.24	30.22	4.85	23.98	52.85	74	-21.15	PK	PASS
H	2500.00	36.88	30.22	4.85	23.98	35.49	54	-18.51	AV	PASS
V	2483.50	52.37	30.22	4.85	23.98	50.98	74	-23.02	PK	PASS
V	2483.50	40.21	30.22	4.85	23.98	38.82	54	-15.18	AV	PASS
V	2500.00	52.28	30.22	4.85	23.98	50.89	74	-23.11	PK	PASS
V	2500.00	38.52	30.22	4.85	23.98	37.13	54	-16.87	AV	PASS

ANT1-802.11n40

Polar (H/V)	Frequency (MHz)	Meter Reading (dBuV)	Pre-amplifier (dB)	Cable Loss (dB)	Antenna Factor (dB/m)	Emission level (dBuV/m)	Limit (dBuV/m)	Margin (dBuV/m)	Detect or Type	Result
Low Channel 2422MHz										
H	2390.00	50.82	30.22	4.85	23.98	49.43	74	-24.57	PK	PASS
H	2390.00	38.55	30.22	4.85	23.98	37.16	54	-16.84	AV	PASS
H	2400.00	53.76	30.22	4.85	23.98	52.37	74	-21.63	PK	PASS
H	2400.00	38.86	30.22	4.85	23.98	37.47	54	-16.53	AV	PASS
V	2390.00	52.72	30.22	4.85	23.98	51.33	74	-22.67	PK	PASS
V	2390.00	39.94	30.22	4.85	23.98	38.55	54	-15.45	AV	PASS
V	2400.00	52.69	30.22	4.85	23.98	51.30	74	-22.70	PK	PASS
V	2400.00	38.61	30.22	4.85	23.98	37.22	54	-16.78	AV	PASS
High Channel 2452MHz										
H	2483.50	52.66	30.22	4.85	23.98	51.27	74	-22.73	PK	PASS
H	2483.50	38.22	30.22	4.85	23.98	36.83	54	-17.17	AV	PASS
H	2500.00	52.95	30.22	4.85	23.98	51.56	74	-22.44	PK	PASS
H	2500.00	36.76	30.22	4.85	23.98	35.37	54	-18.63	AV	PASS
V	2483.50	53.72	30.22	4.85	23.98	52.33	74	-21.67	PK	PASS
V	2483.50	39.06	30.22	4.85	23.98	37.67	54	-16.33	AV	PASS
V	2500.00	54.57	30.22	4.85	23.98	53.18	74	-20.82	PK	PASS
V	2500.00	38.22	30.22	4.85	23.98	36.83	54	-17.17	AV	PASS

Remark:

1. Emission Level = Meter Reading + Antenna Factor + Cable Loss – Pre-amplifier, Margin= Emission Level - Limit

ANT2-802.11b

Polar (H/V)	Frequency (MHz)	Meter Reading (dBuV)	Pre-amplifier (dB)	Cable Loss (dB)	Antenna Factor (dB/m)	Emission level (dBuV/m)	Limit (dBuV/m)	Margin (dBuV/m)	Detect or Type	Result
Low Channel 2412MHz										
H	2390.00	51.81	30.22	4.85	23.98	50.42	74	-23.58	PK	PASS
H	2390.00	37.69	30.22	4.85	23.98	36.30	54	-17.70	AV	PASS
H	2400.00	53.44	30.22	4.85	23.98	52.05	74	-21.95	PK	PASS
H	2400.00	37.57	30.22	4.85	23.98	36.18	54	-17.82	AV	PASS
V	2390.00	53.46	30.22	4.85	23.98	52.07	74	-21.93	PK	PASS
V	2390.00	37.54	30.22	4.85	23.98	36.15	54	-17.85	AV	PASS
V	2400.00	54.36	30.22	4.85	23.98	52.97	74	-21.03	PK	PASS
V	2400.00	37.17	30.22	4.85	23.98	35.78	54	-18.22	AV	PASS
High Channel 2462MHz										
H	2483.50	52.63	30.22	4.85	23.98	51.24	74	-22.76	PK	PASS
H	2483.50	40.02	30.22	4.85	23.98	38.63	54	-15.37	AV	PASS
H	2500.00	53.66	30.22	4.85	23.98	52.27	74	-21.73	PK	PASS
H	2500.00	37.00	30.22	4.85	23.98	35.61	54	-18.39	AV	PASS

V	2483.50	53.32	30.22	4.85	23.98	51.93	74	-22.07	PK	PASS
V	2483.50	37.89	30.22	4.85	23.98	36.50	54	-17.50	AV	PASS
V	2500.00	52.48	30.22	4.85	23.98	51.09	74	-22.91	PK	PASS
V	2500.00	36.87	30.22	4.85	23.98	35.48	54	-18.52	AV	PASS

ANT2-802.11g

Polar (H/V)	Frequency (MHz)	Meter Reading (dBuV)	Pre-amplifier (dB)	Cable Loss (dB)	Antenna Factor (dB/m)	Emission level (dBuV/m)	Limit (dBuV/m)	Margin (dBuV/m)	Detect or Type	Result
Low Channel 2412MHz										
H	2390.00	53.40	30.22	4.85	23.98	52.01	74	-21.99	PK	PASS
H	2390.00	39.98	30.22	4.85	23.98	38.59	54	-15.41	AV	PASS
H	2400.00	53.69	30.22	4.85	23.98	52.30	74	-21.70	PK	PASS
H	2400.00	38.48	30.22	4.85	23.98	37.09	54	-16.91	AV	PASS
V	2390.00	51.78	30.22	4.85	23.98	50.39	74	-23.61	PK	PASS
V	2390.00	39.29	30.22	4.85	23.98	37.90	54	-16.10	AV	PASS
V	2400.00	51.88	30.22	4.85	23.98	50.49	74	-23.51	PK	PASS
V	2400.00	36.53	30.22	4.85	23.98	35.14	54	-18.86	AV	PASS
High Channel 2462MHz										
H	2483.50	51.99	30.22	4.85	23.98	50.60	74	-23.40	PK	PASS
H	2483.50	37.47	30.22	4.85	23.98	36.08	54	-17.92	AV	PASS
H	2500.00	54.70	30.22	4.85	23.98	53.31	74	-20.69	PK	PASS
H	2500.00	37.60	30.22	4.85	23.98	36.21	54	-17.79	AV	PASS
V	2483.50	52.37	30.22	4.85	23.98	50.98	74	-23.02	PK	PASS
V	2483.50	39.81	30.22	4.85	23.98	38.42	54	-15.58	AV	PASS
V	2500.00	53.47	30.22	4.85	23.98	52.08	74	-21.92	PK	PASS
V	2500.00	37.66	30.22	4.85	23.98	36.27	54	-17.73	AV	PASS

ANT2-802.11n20

Polar (H/V)	Frequency (MHz)	Meter Reading (dBuV)	Pre-amplifier (dB)	Cable Loss (dB)	Antenna Factor (dB/m)	Emission level (dBuV/m)	Limit (dBuV/m)	Margin (dBuV/m)	Detect or Type	Result
Low Channel 2412MHz										
H	2390.00	51.31	30.22	4.85	23.98	49.92	74	-24.08	PK	PASS
H	2390.00	37.86	30.22	4.85	23.98	36.47	54	-17.53	AV	PASS
H	2400.00	54.13	30.22	4.85	23.98	52.74	74	-21.26	PK	PASS
H	2400.00	37.11	30.22	4.85	23.98	35.72	54	-18.28	AV	PASS
V	2390.00	52.52	30.22	4.85	23.98	51.13	74	-22.87	PK	PASS
V	2390.00	38.36	30.22	4.85	23.98	36.97	54	-17.03	AV	PASS
V	2400.00	53.52	30.22	4.85	23.98	52.13	74	-21.87	PK	PASS
V	2400.00	36.70	30.22	4.85	23.98	35.31	54	-18.69	AV	PASS
High Channel 2462MHz										
H	2483.50	50.98	30.22	4.85	23.98	49.59	74	-24.41	PK	PASS
H	2483.50	37.55	30.22	4.85	23.98	36.16	54	-17.84	AV	PASS
H	2500.00	52.96	30.22	4.85	23.98	51.57	74	-22.43	PK	PASS
H	2500.00	37.11	30.22	4.85	23.98	35.72	54	-18.28	AV	PASS
V	2483.50	51.17	30.22	4.85	23.98	49.78	74	-24.22	PK	PASS
V	2483.50	37.97	30.22	4.85	23.98	36.58	54	-17.42	AV	PASS
V	2500.00	53.07	30.22	4.85	23.98	51.68	74	-22.32	PK	PASS
V	2500.00	37.70	30.22	4.85	23.98	36.31	54	-17.69	AV	PASS

ANT2-802.11n40

Polar (H/V)	Frequency (MHz)	Meter Reading (dBuV)	Pre-amplifier (dB)	Cable Loss (dB)	Antenna Factor (dB/m)	Emission level (dBuV/m)	Limit (dBuV/m)	Margin (dBuV/m)	Detect or Type	Result
Low Channel 2422MHz										
H	2390.00	53.51	30.22	4.85	23.98	52.12	74	-21.88	PK	PASS
H	2390.00	39.38	30.22	4.85	23.98	37.99	54	-16.01	AV	PASS
H	2400.00	53.86	30.22	4.85	23.98	52.47	74	-21.53	PK	PASS
H	2400.00	36.31	30.22	4.85	23.98	34.92	54	-19.08	AV	PASS
V	2390.00	52.94	30.22	4.85	23.98	51.55	74	-22.45	PK	PASS
V	2390.00	37.30	30.22	4.85	23.98	35.91	54	-18.09	AV	PASS
V	2400.00	54.35	30.22	4.85	23.98	52.96	74	-21.04	PK	PASS
V	2400.00	36.27	30.22	4.85	23.98	34.88	54	-19.12	AV	PASS
High Channel 2452MHz										
H	2483.50	53.06	30.22	4.85	23.98	51.67	74	-22.33	PK	PASS
H	2483.50	38.37	30.22	4.85	23.98	36.98	54	-17.02	AV	PASS
H	2500.00	52.81	30.22	4.85	23.98	51.42	74	-22.58	PK	PASS
H	2500.00	39.04	30.22	4.85	23.98	37.65	54	-16.35	AV	PASS
V	2483.50	52.14	30.22	4.85	23.98	50.75	74	-23.25	PK	PASS
V	2483.50	37.48	30.22	4.85	23.98	36.09	54	-17.91	AV	PASS
V	2500.00	53.71	30.22	4.85	23.98	52.32	74	-21.68	PK	PASS
V	2500.00	39.10	30.22	4.85	23.98	37.71	54	-16.29	AV	PASS

Remark:

1. Emission Level = Meter Reading + Antenna Factor + Cable Loss – Pre-amplifier, Margin= Emission Level - Limit

MIMO-802.11n20

Polar (H/V)	Frequency (MHz)	Meter Reading (dBuV)	Pre-amplifier (dB)	Cable Loss (dB)	Antenna Factor (dB/m)	Emission level (dBuV/m)	Limit (dBuV/m)	Margin (dBuV/m)	Detect or Type	Result
Low Channel 2412MHz										
H	2390.00	52.14	30.22	4.85	23.98	50.75	74	-23.25	PK	PASS
H	2390.00	37.81	30.22	4.85	23.98	36.42	54	-17.58	AV	PASS
H	2400.00	54.20	30.22	4.85	23.98	52.81	74	-21.19	PK	PASS
H	2400.00	38.89	30.22	4.85	23.98	37.50	54	-16.50	AV	PASS
V	2390.00	52.75	30.22	4.85	23.98	51.36	74	-22.64	PK	PASS
V	2390.00	37.77	30.22	4.85	23.98	36.38	54	-17.62	AV	PASS
V	2400.00	52.96	30.22	4.85	23.98	51.57	74	-22.43	PK	PASS
V	2400.00	38.08	30.22	4.85	23.98	36.69	54	-17.31	AV	PASS
High Channel 2462MHz										
H	2483.50	53.09	30.22	4.85	23.98	51.70	74	-22.30	PK	PASS
H	2483.50	37.64	30.22	4.85	23.98	36.25	54	-17.75	AV	PASS
H	2500.00	53.72	30.22	4.85	23.98	52.33	74	-21.67	PK	PASS
H	2500.00	36.38	30.22	4.85	23.98	34.99	54	-19.01	AV	PASS
V	2483.50	52.53	30.22	4.85	23.98	51.14	74	-22.86	PK	PASS
V	2483.50	39.34	30.22	4.85	23.98	37.95	54	-16.05	AV	PASS
V	2500.00	52.60	30.22	4.85	23.98	51.21	74	-22.79	PK	PASS
V	2500.00	38.05	30.22	4.85	23.98	36.66	54	-17.34	AV	PASS

802.11n40

Polar (H/V)	Frequency (MHz)	Meter Reading (dBuV)	Pre-amplifier (dB)	Cable Loss (dB)	Antenna Factor (dB/m)	Emission level (dBuV/m)	Limit (dBuV/m)	Margin (dBuV/m)	Detect or Type	Result
Low Channel 2422MHz										
H	2390.00	50.91	30.22	4.85	23.98	49.52	74	-24.48	PK	PASS
H	2390.00	39.67	30.22	4.85	23.98	38.28	54	-15.72	AV	PASS

H	2400.00	54.40	30.22	4.85	23.98	53.01	74	-20.99	PK	PASS
H	2400.00	37.54	30.22	4.85	23.98	36.15	54	-17.85	AV	PASS
V	2390.00	53.28	30.22	4.85	23.98	51.89	74	-22.11	PK	PASS
V	2390.00	38.21	30.22	4.85	23.98	36.82	54	-17.18	AV	PASS
V	2400.00	54.27	30.22	4.85	23.98	52.88	74	-21.12	PK	PASS
V	2400.00	38.45	30.22	4.85	23.98	37.06	54	-16.94	AV	PASS
High Channel 2452MHz										
H	2483.50	53.74	30.22	4.85	23.98	52.35	74	-21.65	PK	PASS
H	2483.50	39.52	30.22	4.85	23.98	38.13	54	-15.87	AV	PASS
H	2500.00	54.04	30.22	4.85	23.98	52.65	74	-21.35	PK	PASS
H	2500.00	38.10	30.22	4.85	23.98	36.71	54	-17.29	AV	PASS
V	2483.50	51.40	30.22	4.85	23.98	50.01	74	-23.99	PK	PASS
V	2483.50	37.77	30.22	4.85	23.98	36.38	54	-17.62	AV	PASS
V	2500.00	53.15	30.22	4.85	23.98	51.76	74	-22.24	PK	PASS
V	2500.00	36.76	30.22	4.85	23.98	35.37	54	-18.63	AV	PASS

Remark:

1. Emission Level = Meter Reading + Antenna Factor + Cable Loss – Pre-amplifier, Margin= Emission Level - Limit

6.POWER SPECTRAL DENSITY TEST

Test Requirement:	FCC Part15 C Section 15.247 (e)
Test Method:	KDB558074 D0115.247 Meas Guidance v 05r02

6.1 APPLIED PROCEDURES / LIMIT

FCC Part15 (15.247) , Subpart C				
Section	Test Item	Limit	Frequency Range (MHz)	Result
15.247	Power Spectral Density	8dBm/3kHz	2400-2483.5	PASS

6.2 TEST PROCEDURE

1. Set analyzer center frequency to DTS channel center frequency.
2. Set the span to 1.5 times the DTS bandwidth.
3. Set the RBW to: $3 \text{ kHz} \leq \text{RBW} \leq 100 \text{ kHz}$.
4. Set the VBW $\geq 3 \times \text{RBW}$.
5. Detector = peak.
6. Sweep time = auto couple.
7. Trace mode = max hold.
8. Allow trace to fully stabilize.
9. Use the peak marker function to determine the maximum amplitude level within the RBW.
10. If measured value exceeds limit, reduce RBW (no less than 3 kHz) and repeat.

6.3 DEVIATION FROM STANDARD

No deviation.

6.4 TEST SETUP**6.5 EUT OPERATION CONDITIONS**

The EUT tested system was configured as the statements of 2.1 Unless otherwise a special operating condition is specified in the follows during the testing.

6.6 TEST RESULT

PASS: PLEASE REFER TO APPENDIX: APPENDIX1 FOR DETAILS

7. CHANNEL BANDWIDTH

Test Requirement:	FCC Part15 C Section 15.247 (a)(2)
Test Method:	KDB558074 D0115.247 Meas Guidance v05r02

7.1 APPLIED PROCEDURES / LIMIT

FCC Part15 (15.247) , Subpart C				
Section	Test Item	Limit	Frequency Range (MHz)	Result
15.247(a)(2)	Bandwidth	$\geq 500\text{KHz}$ (6dB bandwidth)	2400-2483.5	PASS

7.2 TEST PROCEDURE

1. Set RBW = 100 kHz.
2. Set the video bandwidth (VBW) $\geq 3 \times \text{RBW}$.
3. Detector = Peak.
4. Trace mode = max hold.
5. Sweep = auto couple.
6. Allow the trace to stabilize.
7. Measure the maximum width of the emission that is constrained by the frequencies associated with the two outermost amplitude points (upper and lower frequencies) that are attenuated by 6 dB relative to the maximum level measured in the fundamental emission.

7.3 DEVIATION FROM STANDARD

No deviation.

7.4 TEST SETUP



7.5 EUT OPERATION CONDITIONS

The EUT tested system was configured as the statements of 2.4 Unless otherwise a special operating condition is specified in the follows during the testing.

7.6 TEST RESULT

PASS: PLEASE REFER TO APPENDIX: APPENDIX1 FOR DETAILS

8. OUTPUT POWER TEST

Test Requirement:	FCC Part15 C Section 15.247 (b)(3)
Test Method:	KDB558074 D0115.247 Meas Guidance v05r02

8.1 APPLIED PROCEDURES/LIMIT

FCC Part15 (15.247) , Subpart C				
Section	Test Item	Limit	Frequency Range (MHz)	Result
15.247(b)(3)	Peak Output Power	1 watt or 30dBm	2400-2483.5	PASS

8.2 TEST PROCEDURE

- a. The EUT was directly connected to the Power meter

8.3 DEVIATION FROM STANDARD

No deviation.

8.4 TEST SETUP**8.5 EUT OPERATION CONDITIONS**

The EUT tested system was configured as the statements of 2.4 Unless otherwise a special operating condition is specified in the follows during the testing.

8.6 TEST RESULT

PASS: PLEASE REFER TO APPENDIX: APPENDIX1 FOR DETAILS

9. CONDUCTED BAND EDGE AND SPURIOUS EMISSION

Test Requirement:	FCC Part15 C Section 15.247 (d)
Test Method:	KDB558074 D0115.247 Meas Guidance v05r02

9.1 APPLICABLE STANDARD

in any 100 kHz bandwidth outside the frequency bands in which the spread spectrum intentional radiator is operating, the radio frequency power that is produced by the intentional radiator shall be at least 20dB below that in the 100kHz bandwidth within the band that contains the highest level of the desired power, In addition, radiated emissions which fall in the restricted bands, as defined in§15.205(a), must also comply with the radiated emission limits specified in15.209(a).

9.2 TEST PROCEDURE

Using the following spectrum analyzer setting:

- A) Set the RBW = 100KHz.
- B) Set the VBW = 300KHz.
- C) Sweep time = auto couple.
- D) Detector function = peak.
- E) Trace mode = max hold.
- F) Allow trace to fully stabilize.

9.3 DEVIATION FROM STANDARD

No deviation.

9.4 TEST SETUP



9.5 EUT OPERATION CONDITIONS

The EUT tested system was configured as the statements of 2.4 Unless otherwise a special operating condition is specified in the follows during the testing.

9.6 TEST RESULTS

PASS: PLEASE REFER TO APPENDIX: APPENDIX1 FOR DETAILS

10. ANTENNA REQUIREMENT

Standard requirement:

FCC Part15 C Section 15.203 /247(c)

For intentional device, according to FCC 47 CFR Section 15.203, an intentional radiator shall be designed to ensure that no antenna other than that furnished by the responsible party shall be used with the device. And according to FCC 47 CFR Section 15.247, if transmitting antennas of directional gain greater than 6dBi are used, the power shall be reduced by the amount in dB that the directional gain of the antenna exceeds 6dBi.

Refer to statement below for compliance.

The manufacturer may design the unit so that the user can replace a broken antenna, but the use of a standard antenna jack or electrical connector is prohibited. Further, this requirement does not apply to intentional radiators that must be professionally installed.

Antenna Connected Construction

The antenna is Internal antenna, the best case gain of the ANT1:4.16dBi; ANT1:4.81dBi;, reference to the below photo for details
ANT for 2.4G WIFI

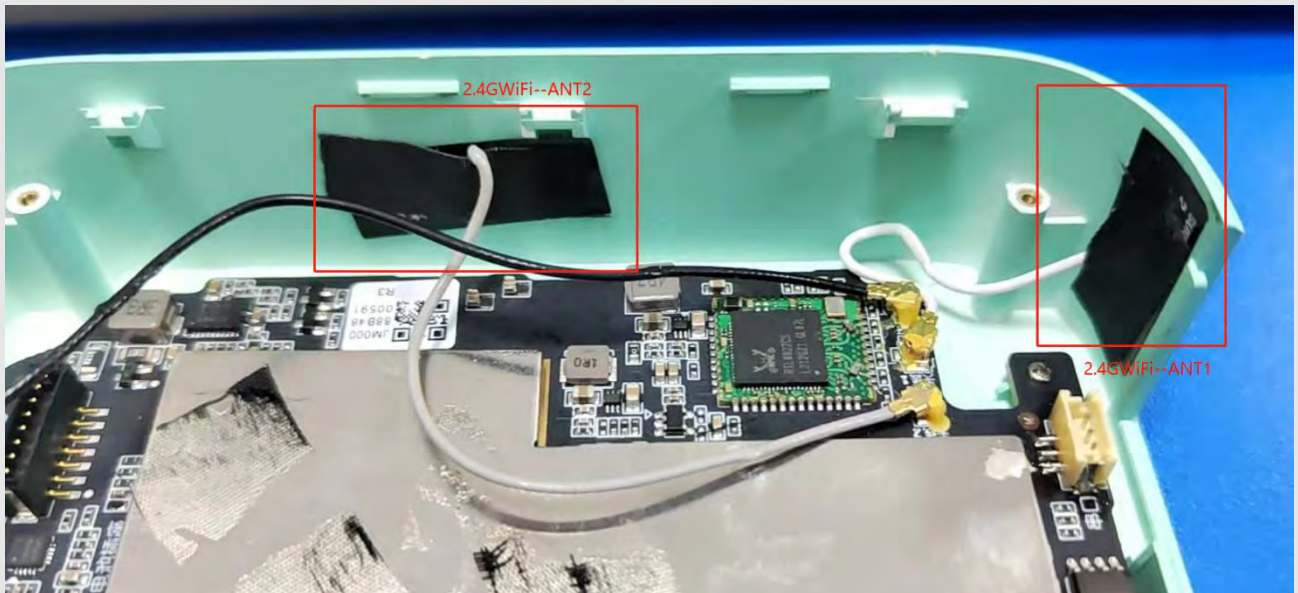

11. Appendix 1

11.1. -6DB BANDWIDTH

Condition	Antenna	Modulation	Frequency (MHz)	-6dB BW(MHz)	limit(kHz)	Result
NVNT	ANT1	802.11b	2412.00	10.98	500	Pass
NVNT	ANT1	802.11b	2437.00	10.98	500	Pass
NVNT	ANT1	802.11b	2462.00	10.07	500	Pass
NVNT	ANT1	802.11g	2412.00	16.39	500	Pass
NVNT	ANT1	802.11g	2437.00	16.05	500	Pass
NVNT	ANT1	802.11g	2462.00	16.33	500	Pass
NVNT	ANT1	802.11n(HT20)	2412.00	16.06	500	Pass
NVNT	ANT1	802.11n(HT20)	2437.00	15.05	500	Pass
NVNT	ANT1	802.11n(HT20)	2462.00	16.18	500	Pass
NVNT	ANT1	802.11n(HT40)	2422.00	35.24	500	Pass
NVNT	ANT1	802.11n(HT40)	2437.00	35.79	500	Pass
NVNT	ANT1	802.11n(HT40)	2452.00	35.60	500	Pass

Condition	Antenna	Modulation	Frequency (MHz)	-6dB BW(MHz)	limit(kHz)	Result
NVNT	ANT2	802.11b	2412.00	11.655	500	Pass
NVNT	ANT2	802.11b	2437.00	11.175	500	Pass
NVNT	ANT2	802.11b	2462.00	10.204	500	Pass
NVNT	ANT2	802.11g	2412.00	15.846	500	Pass
NVNT	ANT2	802.11g	2437.00	15.982	500	Pass
NVNT	ANT2	802.11g	2462.00	15.981	500	Pass
NVNT	ANT2	802.11n(HT20)	2412.00	17.302	500	Pass
NVNT	ANT2	802.11n(HT20)	2437.00	15.838	500	Pass
NVNT	ANT2	802.11n(HT20)	2462.00	16.407	500	Pass
NVNT	ANT2	802.11n(HT40)	2422.00	35.235	500	Pass
NVNT	ANT2	802.11n(HT40)	2437.00	35.811	500	Pass
NVNT	ANT2	802.11n(HT40)	2452.00	35.250	500	Pass

-6dB_Bandwidth_2_4WiFi_2412_00-ANT1

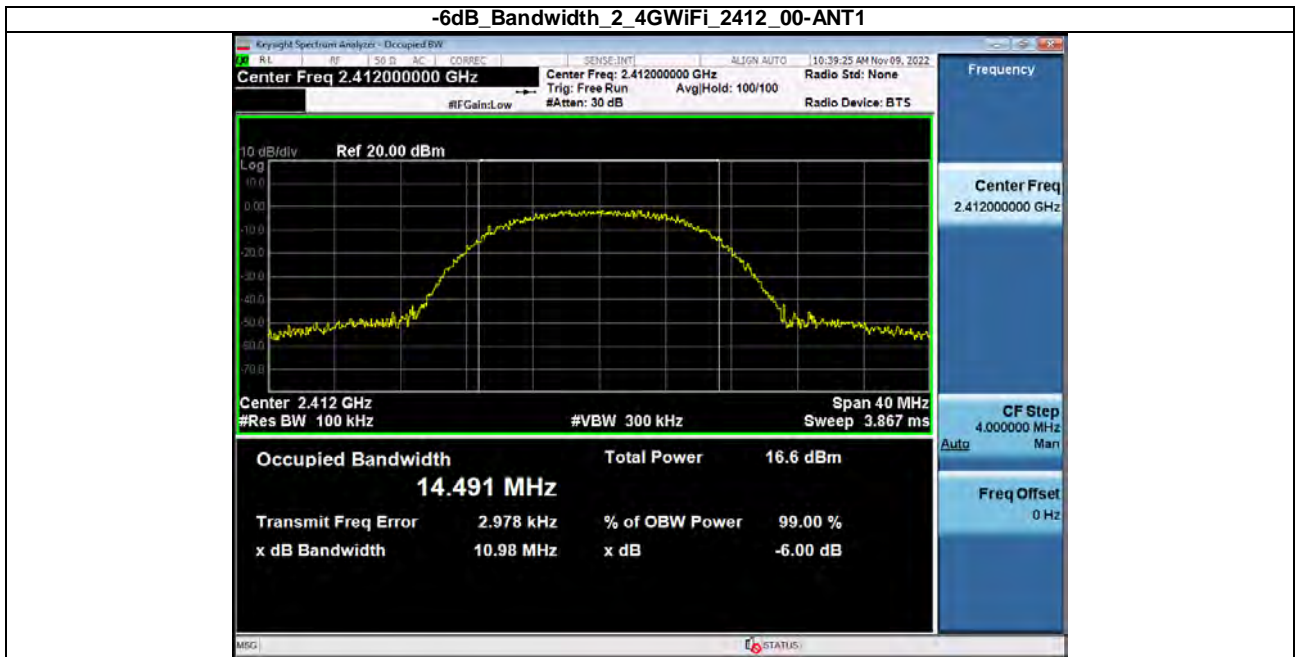

-6dB_Bandwidth_2_4WiFi_2437_00-ANT1



-6dB_Bandwidth_2_4WiFi_2462_00-ANT1



-6dB_Bandwidth_2_4GWiFi_2412_00-ANT1

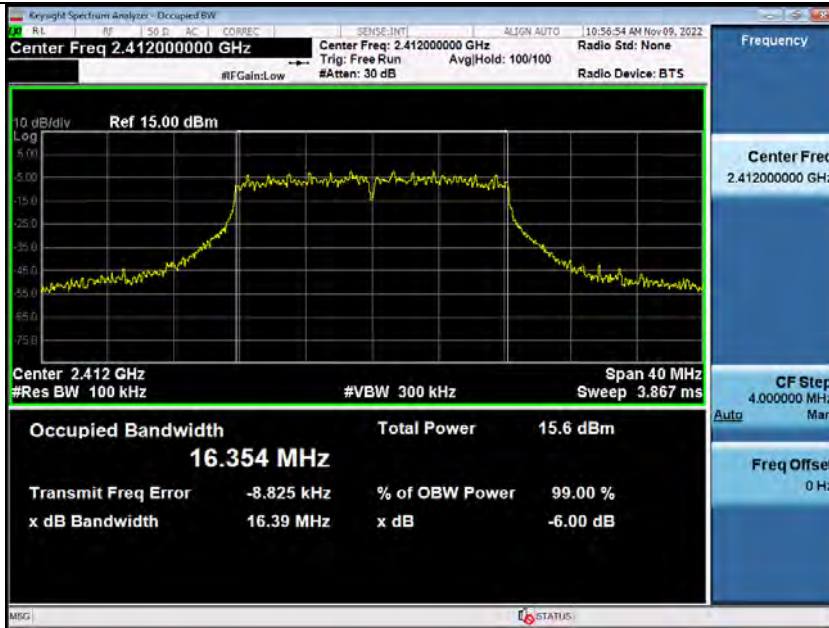

-6dB_Bandwidth_2_4GWiFi_2437_00-ANT1

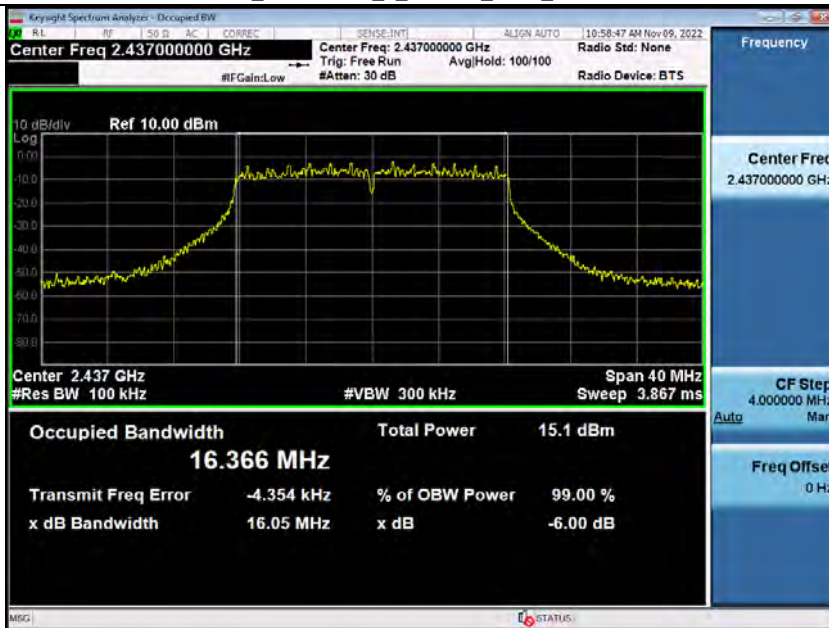

-6dB_Bandwidth_2_4GWiFi_2462_00-ANT1

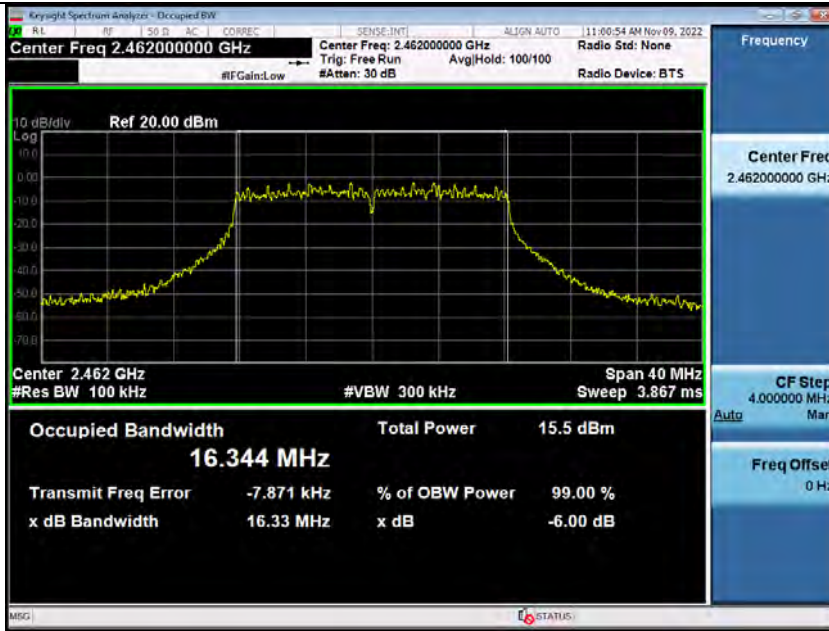

-6dB_Bandwidth_2_4GWiFi_2412_00-ANT1



-6dB_Bandwidth_2_4WiFi_2437_00-ANT1



-6dB_Bandwidth_2_4WiFi_2462_00-ANT1



-6dB_Bandwidth_2_4WiFi_2422_00-ANT1

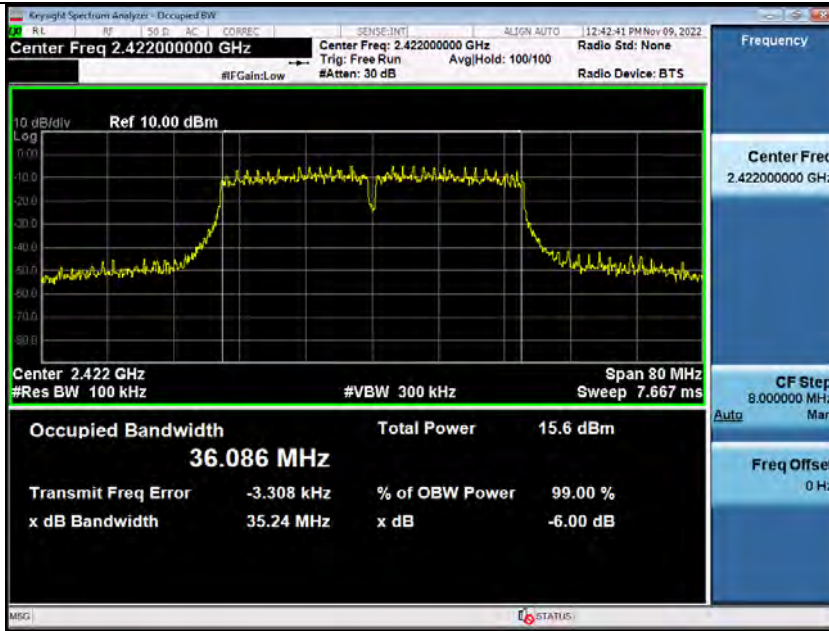

-6dB_Bandwidth_2_4WiFi_2437_00-ANT1

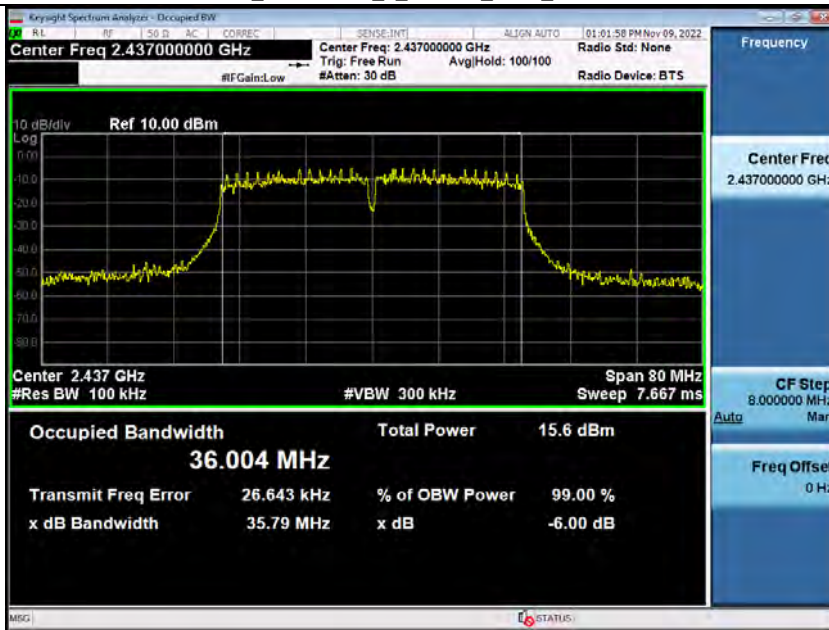

-6dB_Bandwidth_2_4WiFi_2452_00-ANT1

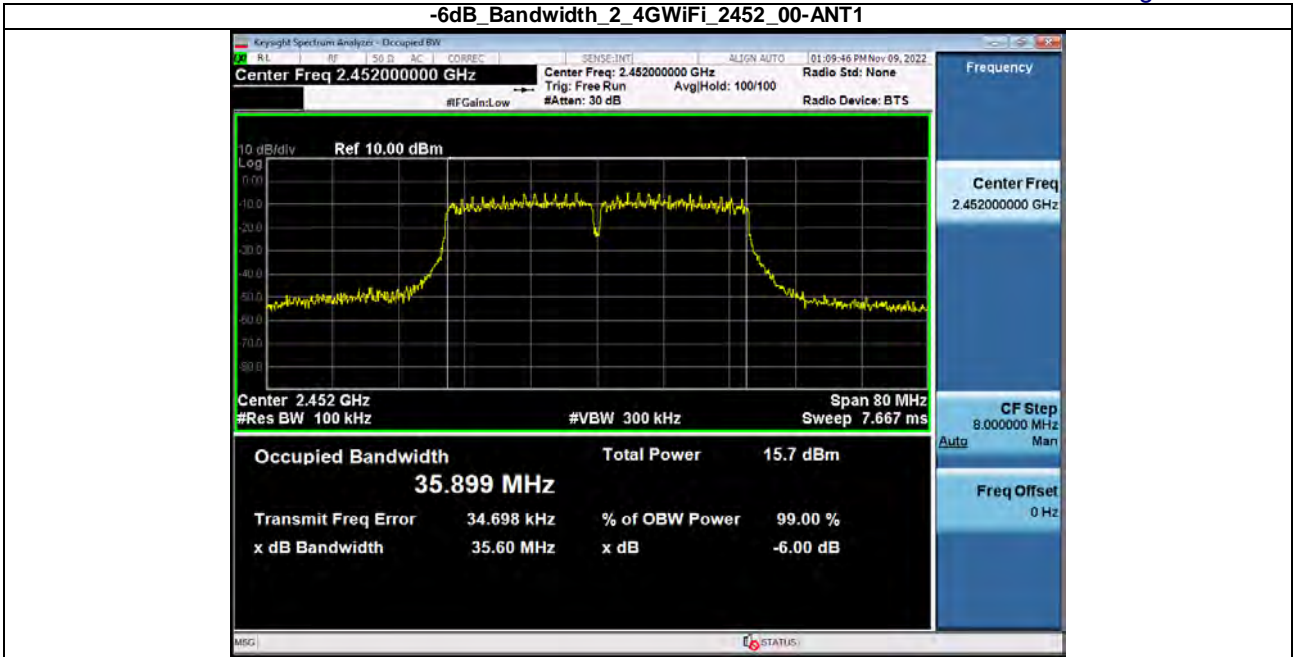

-6dB_Bandwidth_2_4WiFi_2412_00-ANT2

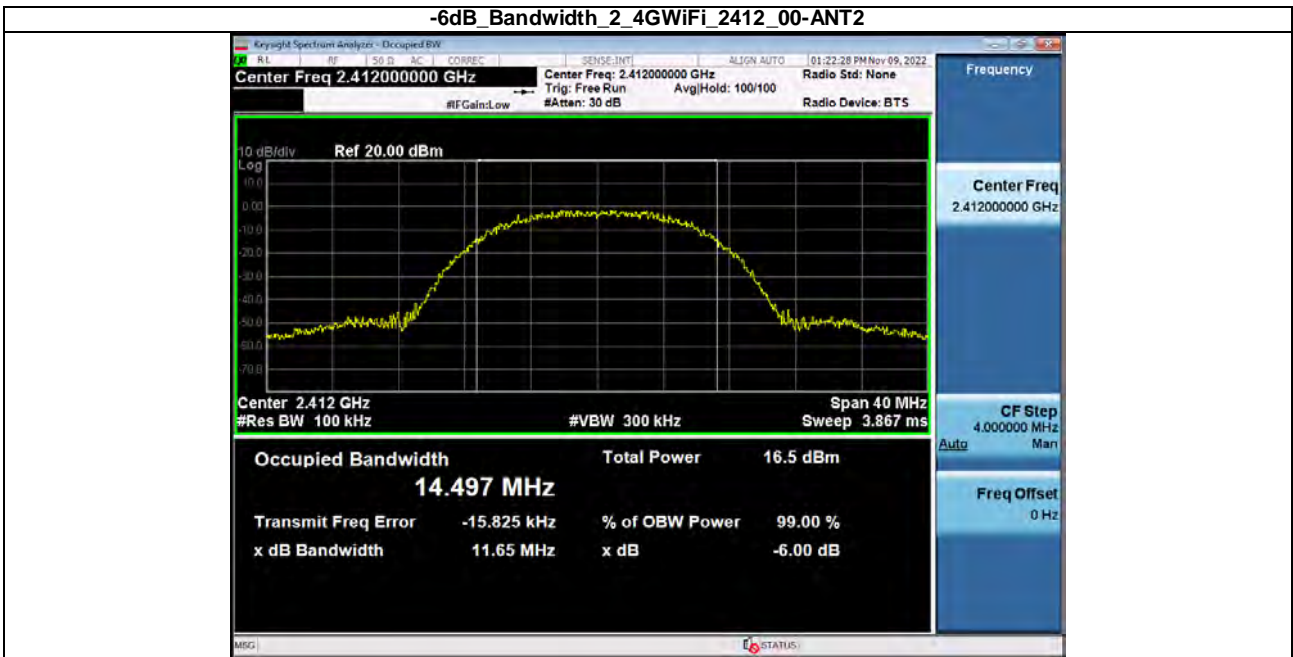

-6dB_Bandwidth_2_4WiFi_2437_00-ANT2



-6dB_Bandwidth_2_4WiFi_2462_00-ANT2

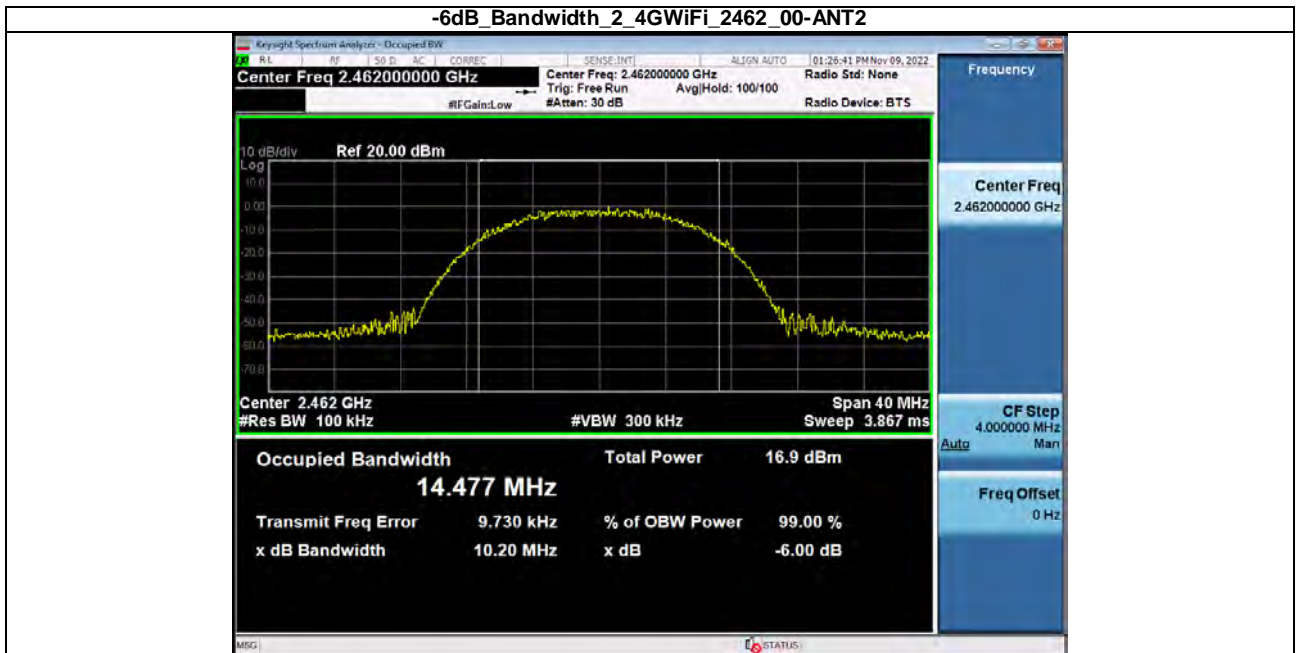

-6dB_Bandwidth_2_4WiFi_2412_00-ANT2

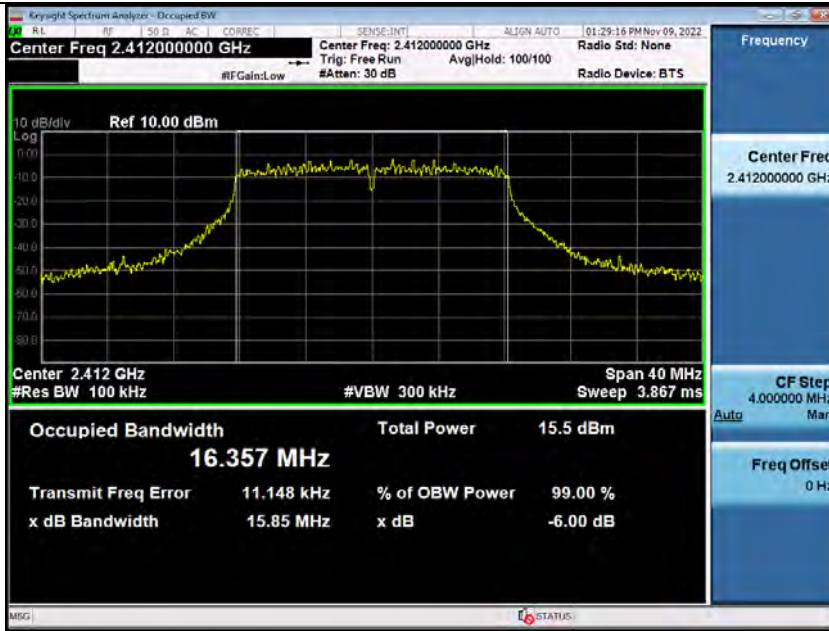

-6dB_Bandwidth_2_4WiFi_2437_00-ANT2

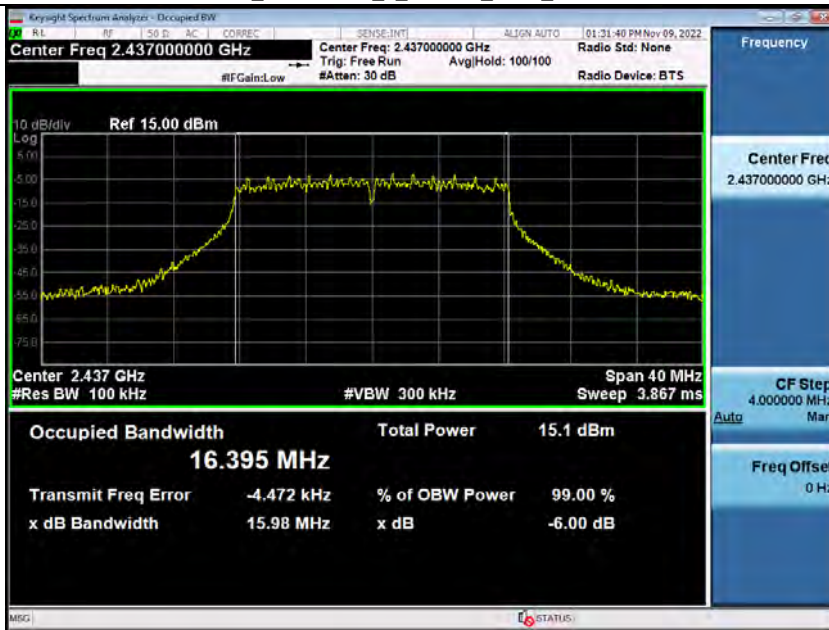

-6dB_Bandwidth_2_4WiFi_2462_00-ANT2



-6dB_Bandwidth_2_4WiFi_2412_00-ANT2

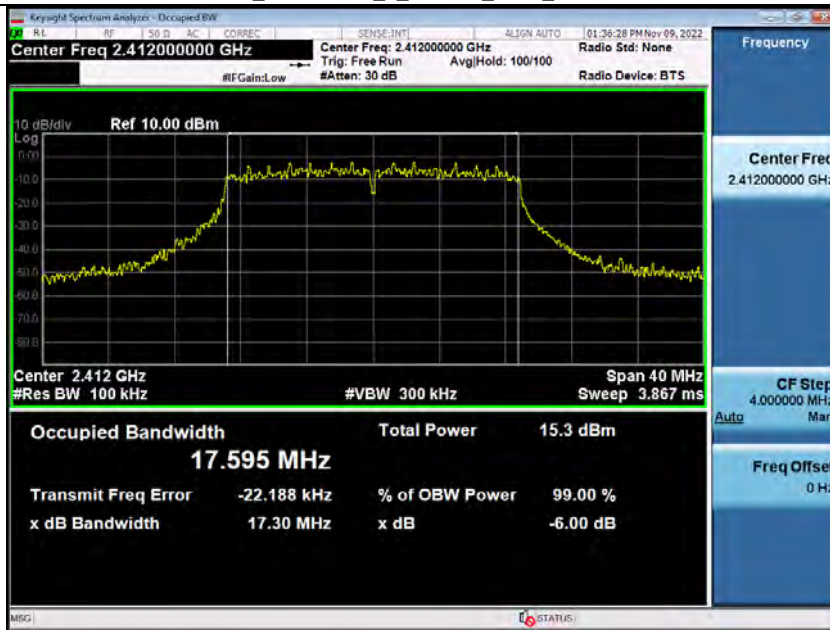

-6dB_Bandwidth_2_4GWiFi_2437_00-ANT2

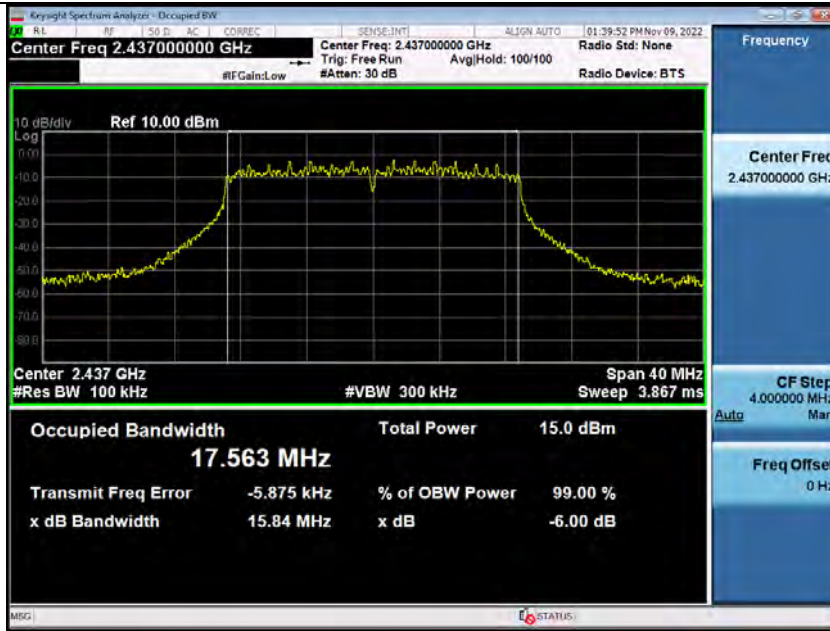

-6dB_Bandwidth_2_4GWiFi_2462_00-ANT2

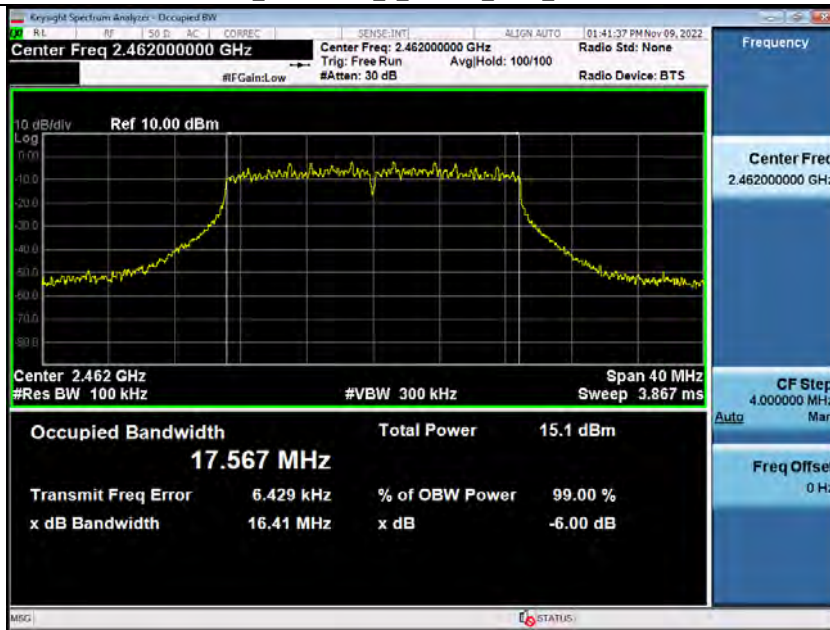

-6dB_Bandwidth_2_4WiFi_2422_00-ANT2

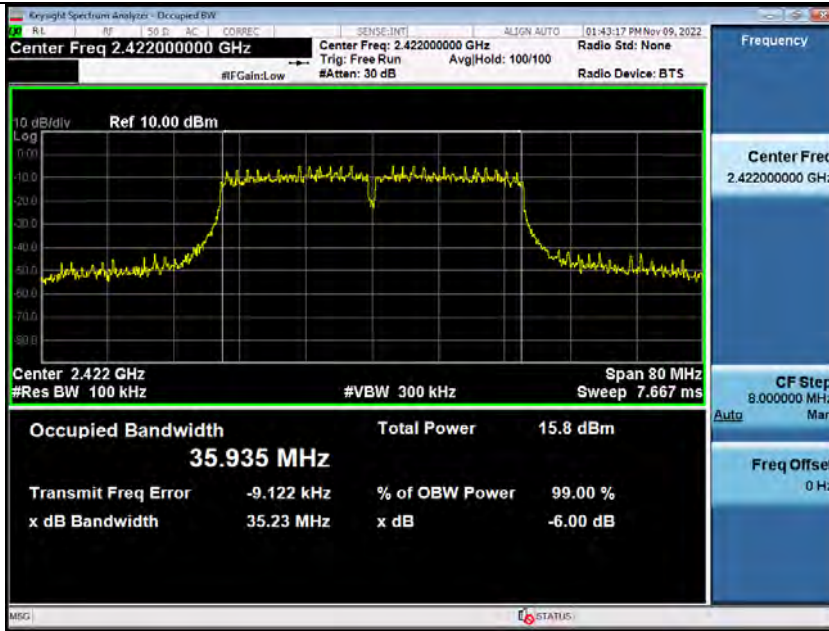

-6dB_Bandwidth_2_4WiFi_2437_00-ANT2

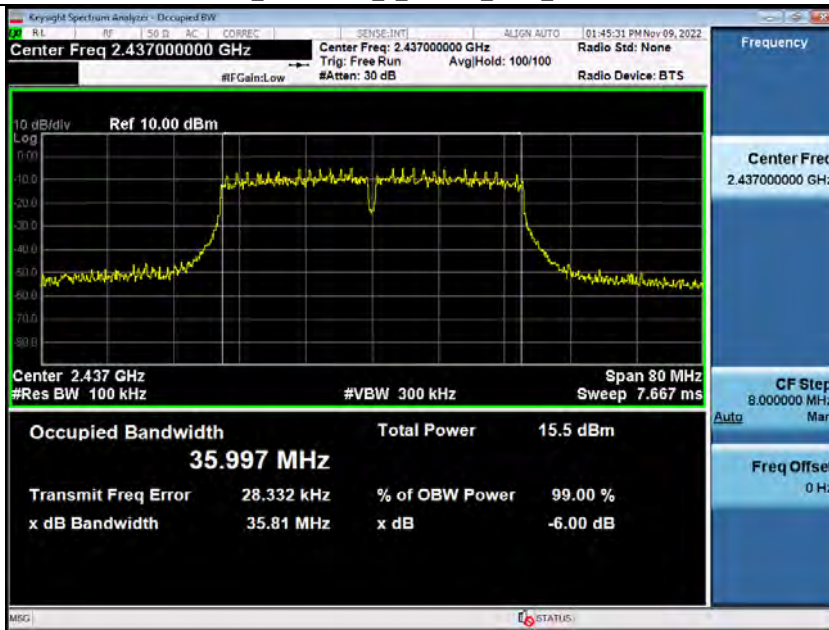

-6dB_Bandwidth_2_4GWiFi_2452_00-ANT2

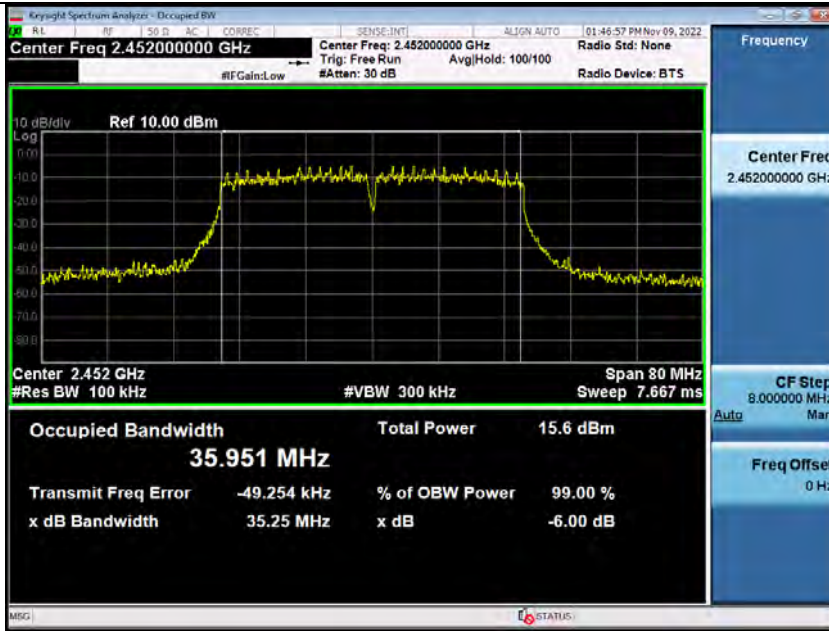

11.3. BANDEDGE

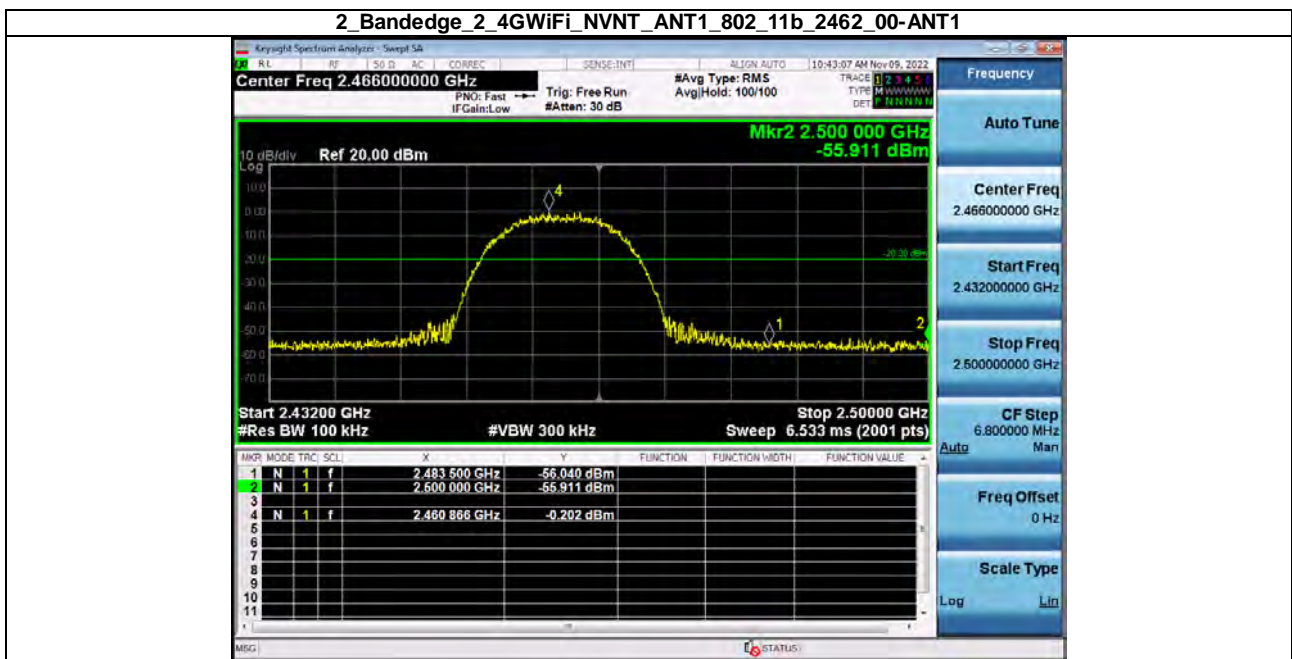
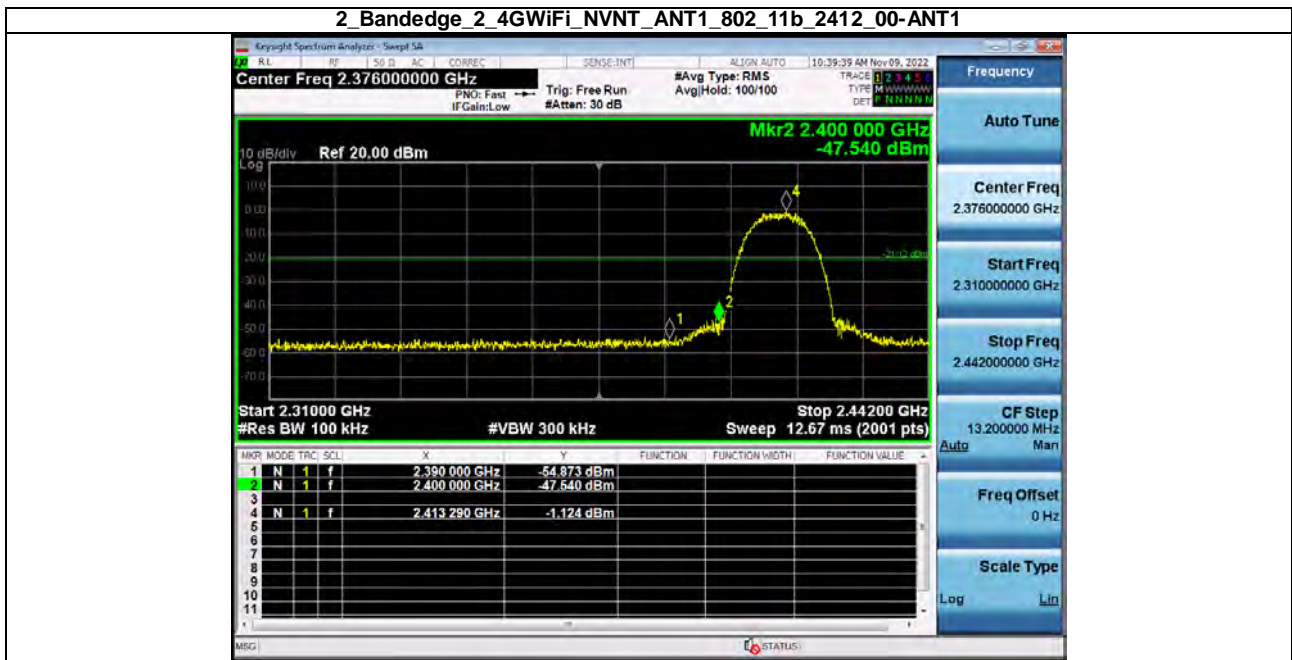

2_Bandedge_2_4GWiFi_NVNT_ANT1_802_11g_2412_00-ANT1

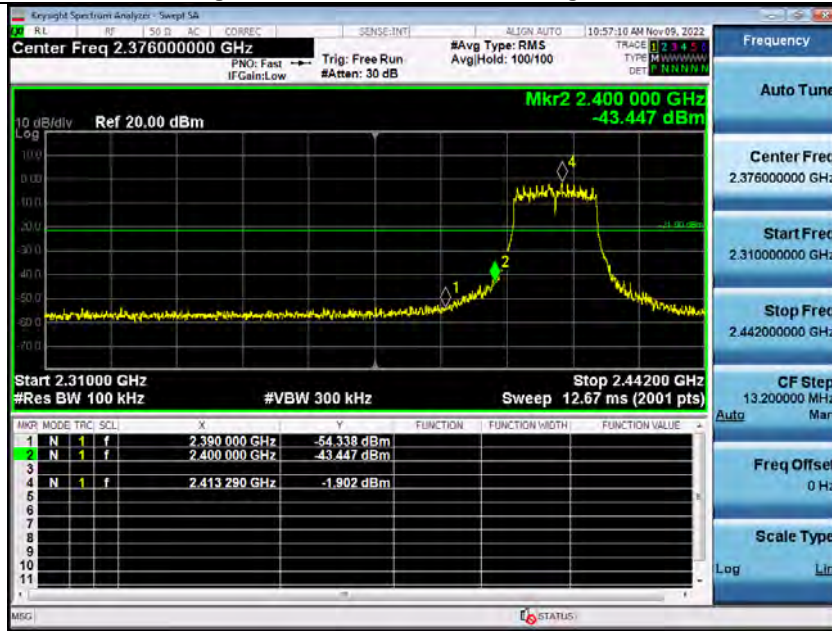

2_Bandedge_2_4GWiFi_NVNT_ANT1_802_11g_2462_00-ANT1

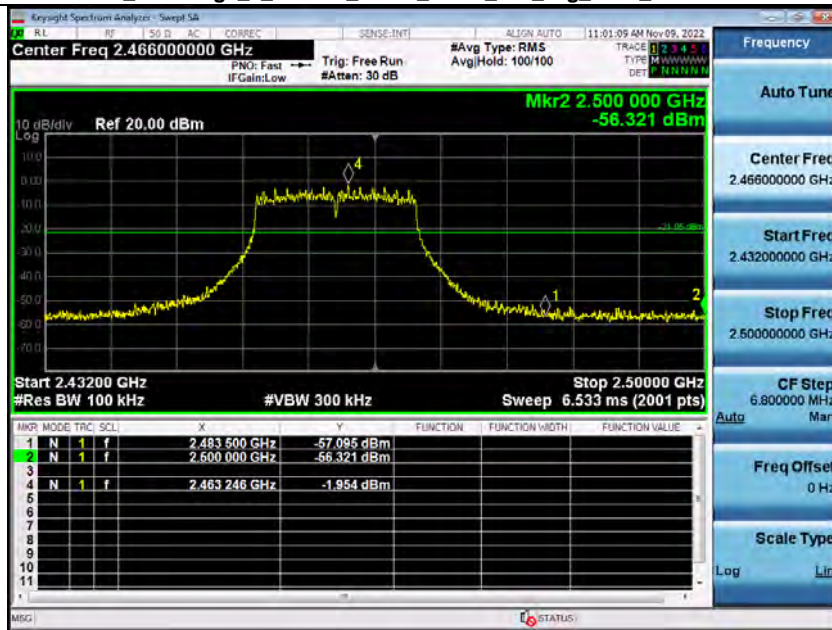

2_Bandedge_2_4GWiFi_NVNT_ANT1_802_11n(HT20)_2412_00-ANT1

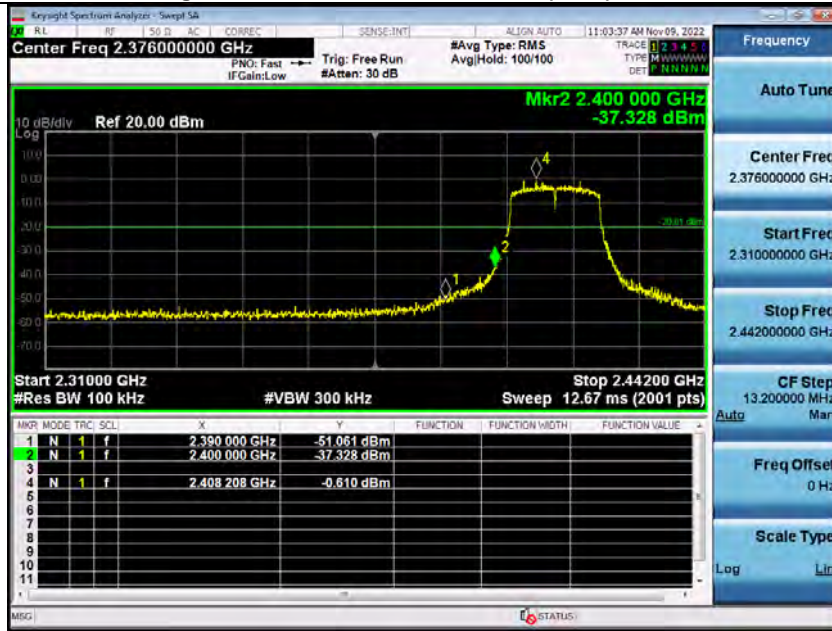

2_Bandedge_2_4GWiFi_NVNT_ANT1_802_11n(HT20)_2462_00-ANT1

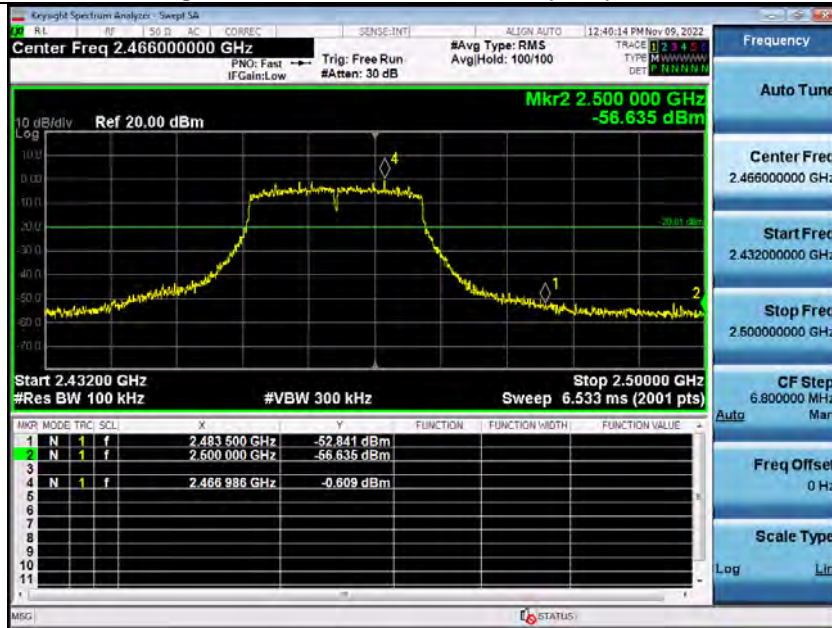

2_Bandedge_2_4GWiFi_NVNT_ANT1_802_11n(HT40)_2422_00-ANT1

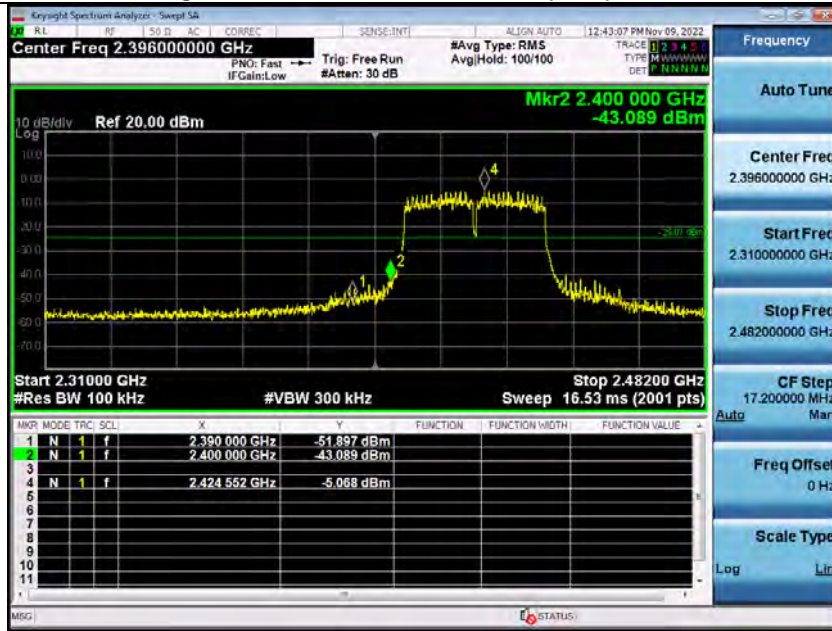

2_Bandedge_2_4GWiFi_NVNT_ANT1_802_11n(HT40)_2452_00-ANT1

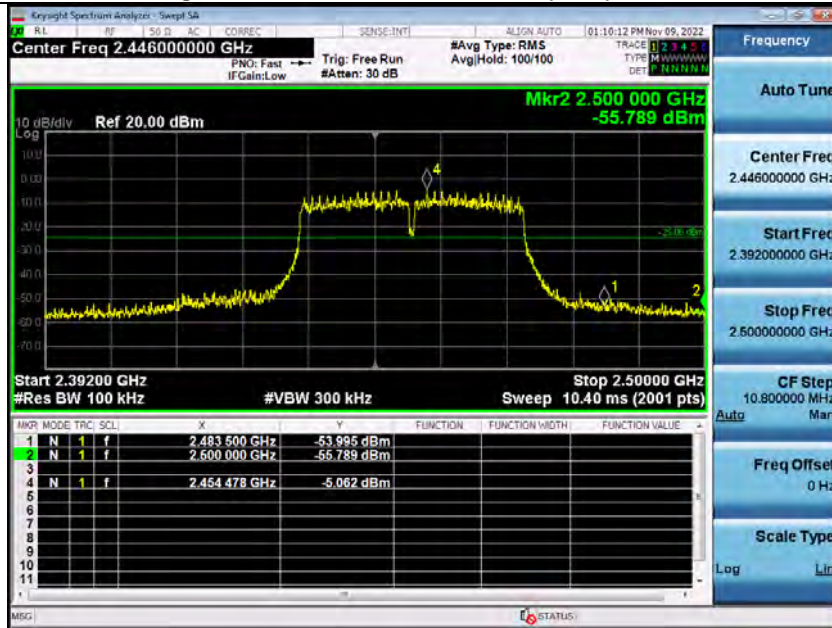

2_Bandedge_2_4GWiFi_NVNT_ANT2_802_11n(HT20)_2412_00-ANT2

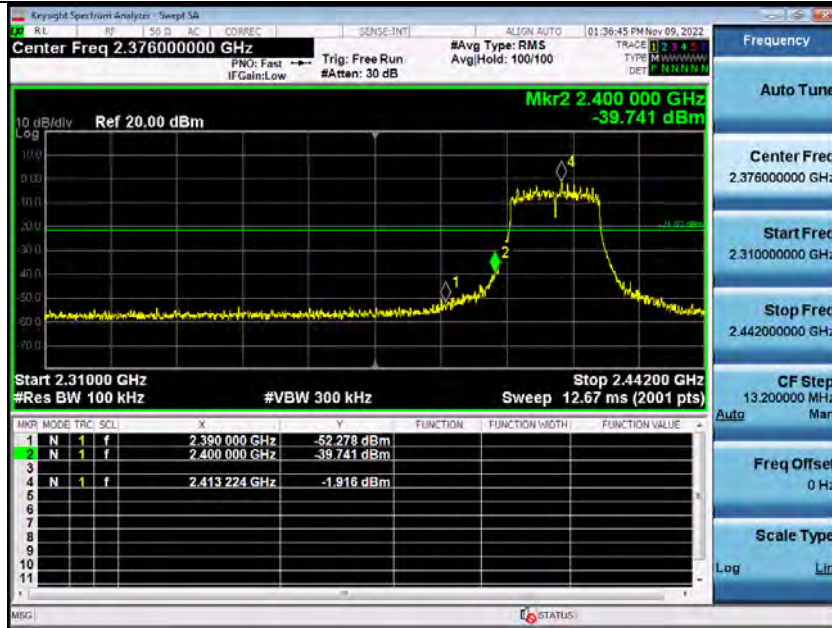

2_Bandedge_2_4GWiFi_NVNT_ANT2_802_11n(HT20)_2462_00-ANT2

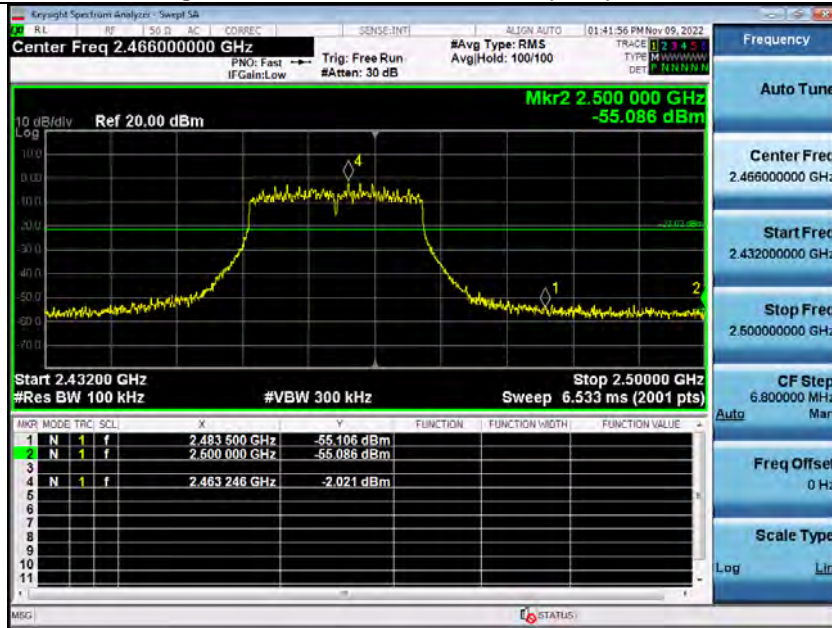

2_Bandedge_2_4GWiFi_NVNT_ANT2_802_11n(HT40)_2422_00-ANT2

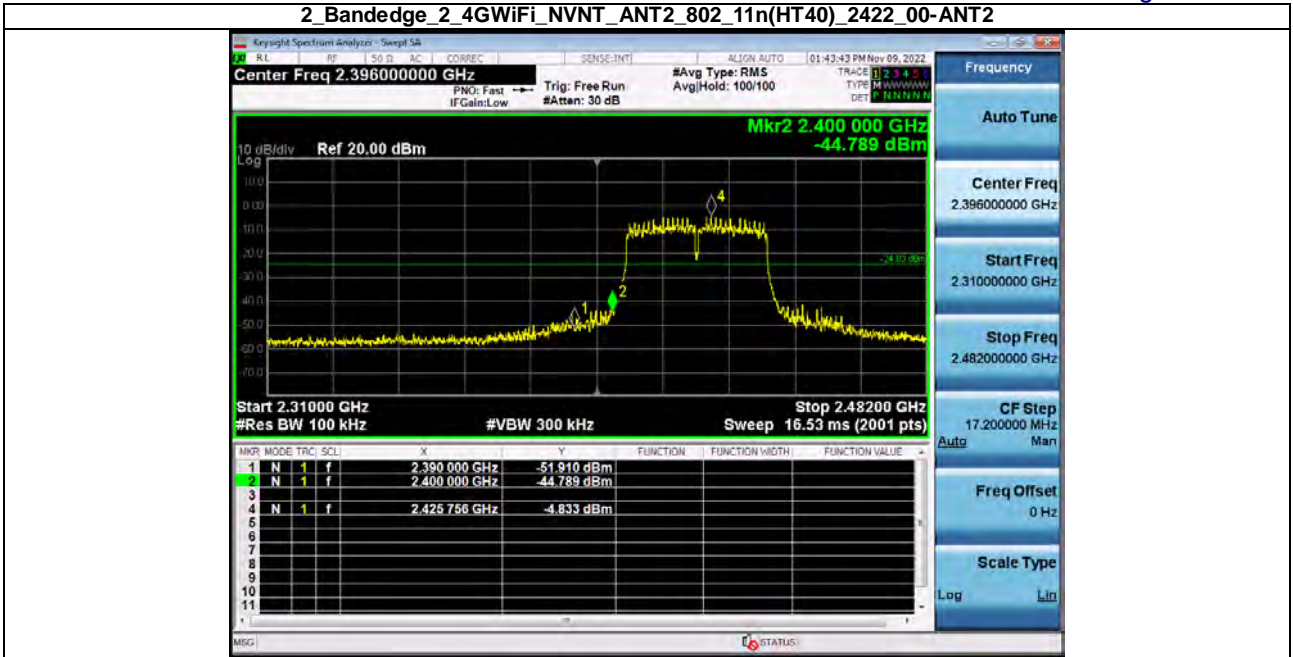

2_Bandedge_2_4GWiFi_NVNT_ANT2_802_11n(HT40)_2452_00-ANT2

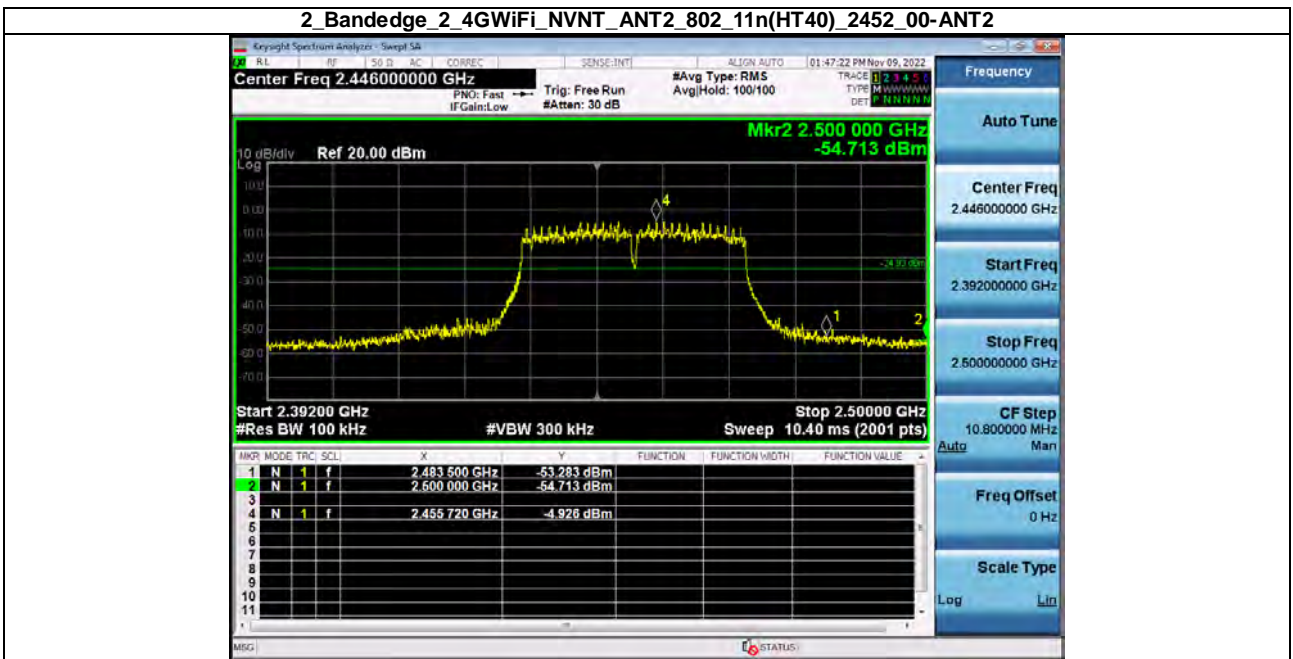

11.4. MAX. OUTPUT POWER

Condition	Antenna	Modulation	Frequency (MHz)	Conducted Power(dBm)	limit(dBm)	Result
NVNT	ANT1	802.11b	2412.00	14.897	30	Pass
NVNT	ANT1	802.11b	2437.00	14.824	30	Pass
NVNT	ANT1	802.11b	2462.00	15.165	30	Pass
NVNT	ANT1	802.11g	2412.00	15.889	30	Pass
NVNT	ANT1	802.11g	2437.00	15.517	30	Pass
NVNT	ANT1	802.11g	2462.00	15.840	30	Pass
NVNT	ANT1	802.11n(HT20)	2412.00	16.821	30	Pass
NVNT	ANT1	802.11n(HT20)	2437.00	16.124	30	Pass
NVNT	ANT1	802.11n(HT20)	2462.00	16.072	30	Pass
NVNT	ANT1	802.11n(HT40)	2422.00	13.426	30	Pass
NVNT	ANT1	802.11n(HT40)	2437.00	13.566	30	Pass
NVNT	ANT1	802.11n(HT40)	2452.00	13.358	30	Pass

Condition	Antenna	Modulation	Frequency (MHz)	Conducted Power(dBm)	limit(dBm)	Result
NVNT	ANT2	802.11b	2412.00	14.799	30	Pass
NVNT	ANT2	802.11b	2437.00	14.776	30	Pass
NVNT	ANT2	802.11b	2462.00	14.940	30	Pass
NVNT	ANT2	802.11g	2412.00	16.032	30	Pass
NVNT	ANT2	802.11g	2437.00	15.346	30	Pass
NVNT	ANT2	802.11g	2462.00	15.819	30	Pass
NVNT	ANT2	802.11n(HT20)	2412.00	15.569	30	Pass
NVNT	ANT2	802.11n(HT20)	2437.00	15.389	30	Pass
NVNT	ANT2	802.11n(HT20)	2462.00	15.440	30	Pass
NVNT	ANT2	802.11n(HT40)	2422.00	13.835	30	Pass
NVNT	ANT2	802.11n(HT40)	2437.00	13.286	30	Pass
NVNT	ANT2	802.11n(HT40)	2452.00	13.573	30	Pass

Condition	Antenna	Modulation	Frequency (MHz)	Conducted Power(dBm)	limit(dBm)	Result
NVNT	MIMO	802.11n(HT20)	2412.00	19.25	30	Pass
NVNT	MIMO	802.11n(HT20)	2437.00	18.78	30	Pass
NVNT	MIMO	802.11n(HT20)	2462.00	18.78	30	Pass
NVNT	MIMO	802.11n(HT40)	2422.00	16.65	30	Pass
NVNT	MIMO	802.11n(HT40)	2437.00	16.44	30	Pass
NVNT	MIMO	802.11n(HT40)	2452.00	16.48	30	Pass

11.5. POWER SPECTRAL DENSITY

Condition	Antenna	Modulation	Frequency (MHz)	PSD(dBm/3kHz)	limit(dBm/3kHz)	Result
NVNT	ANT1	802.11b	2412.00	-15.613	8	Pass
NVNT	ANT1	802.11b	2437.00	-15.911	8	Pass
NVNT	ANT1	802.11b	2462.00	-15.766	8	Pass
NVNT	ANT1	802.11g	2412.00	-16.977	8	Pass
NVNT	ANT1	802.11g	2437.00	-18.236	8	Pass
NVNT	ANT1	802.11g	2462.00	-15.901	8	Pass
NVNT	ANT1	802.11n(HT20)	2412.00	-14.462	8	Pass
NVNT	ANT1	802.11n(HT20)	2437.00	-14.876	8	Pass
NVNT	ANT1	802.11n(HT20)	2462.00	-14.143	8	Pass
NVNT	ANT1	802.11n(HT40)	2422.00	-21.857	8	Pass
NVNT	ANT1	802.11n(HT40)	2437.00	-22.465	8	Pass
NVNT	ANT1	802.11n(HT40)	2452.00	-22.227	8	Pass

Condition	Antenna	Modulation	Frequency (MHz)	PSD(dBm/3kHz)	limit(dBm/3kHz)	Result
NVNT	ANT2	802.11b	2412.00	-15.200	8	Pass
NVNT	ANT2	802.11b	2437.00	-15.439	8	Pass
NVNT	ANT2	802.11b	2462.00	-15.349	8	Pass
NVNT	ANT2	802.11g	2412.00	-16.736	8	Pass
NVNT	ANT2	802.11g	2437.00	-18.231	8	Pass
NVNT	ANT2	802.11g	2462.00	-17.623	8	Pass
NVNT	ANT2	802.11n(HT20)	2412.00	-17.370	8	Pass
NVNT	ANT2	802.11n(HT20)	2437.00	-17.700	8	Pass
NVNT	ANT2	802.11n(HT20)	2462.00	-18.404	8	Pass
NVNT	ANT2	802.11n(HT40)	2422.00	-21.089	8	Pass
NVNT	ANT2	802.11n(HT40)	2437.00	-22.138	8	Pass
NVNT	ANT2	802.11n(HT40)	2452.00	-20.977	8	Pass

Condition	Antenna	Modulation	Frequency (MHz)	PSD(dBm/3kHz)	limit(dBm/3kHz)	Result
NVNT	ANT2	802.11n(HT20)	2412.00	-12.67	6.18	Pass
NVNT	ANT2	802.11n(HT20)	2437.00	-13.05	6.18	Pass
NVNT	ANT2	802.11n(HT20)	2462.00	-12.76	6.18	Pass
NVNT	ANT2	802.11n(HT40)	2422.00	-18.45	6.18	Pass
NVNT	ANT2	802.11n(HT40)	2437.00	-19.29	6.18	Pass
NVNT	ANT2	802.11n(HT40)	2452.00	-18.55	6.18	Pass

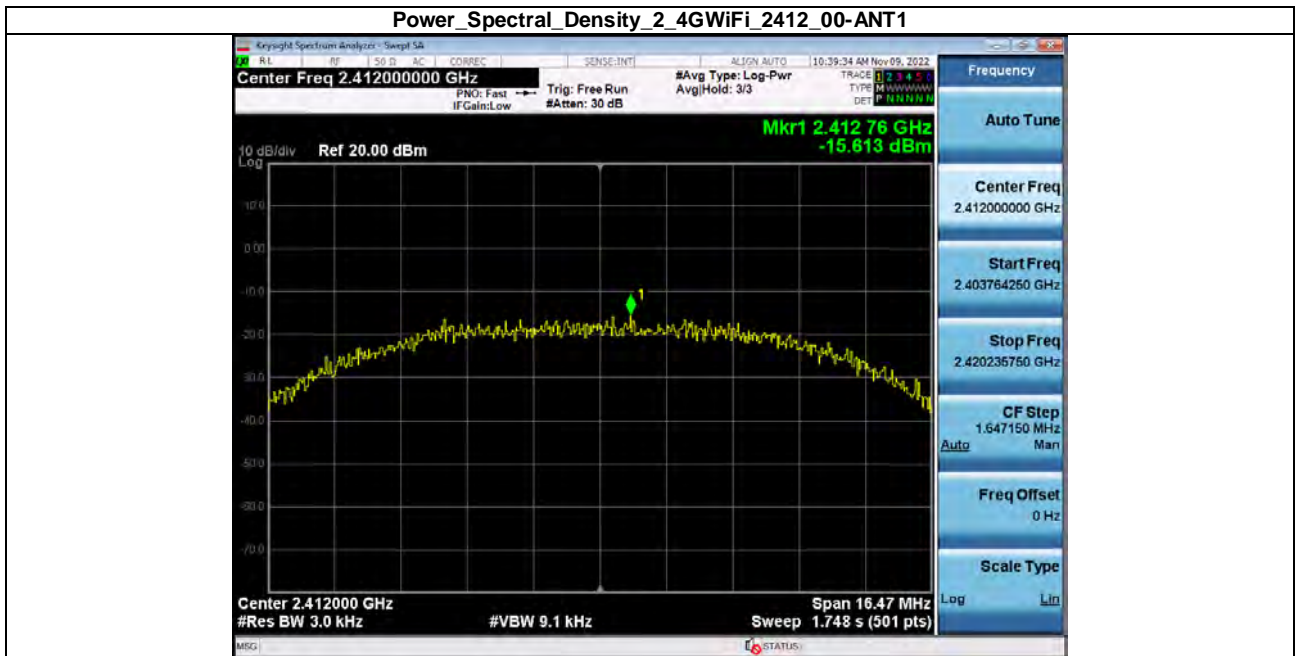

Power_Spectral_Density_2_4GWiFi_2437_00-ANT1



Power_Spectral_Density_2_4GWiFi_2462_00-ANT1



Power_Spectral_Density_2_4WiFi_2412_00-ANT1

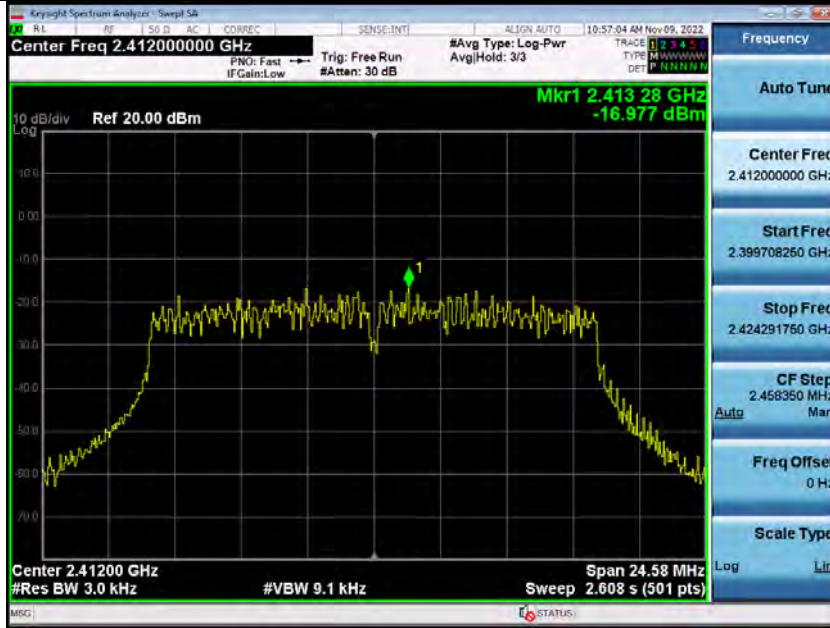

Power_Spectral_Density_2_4WiFi_2437_00-ANT1

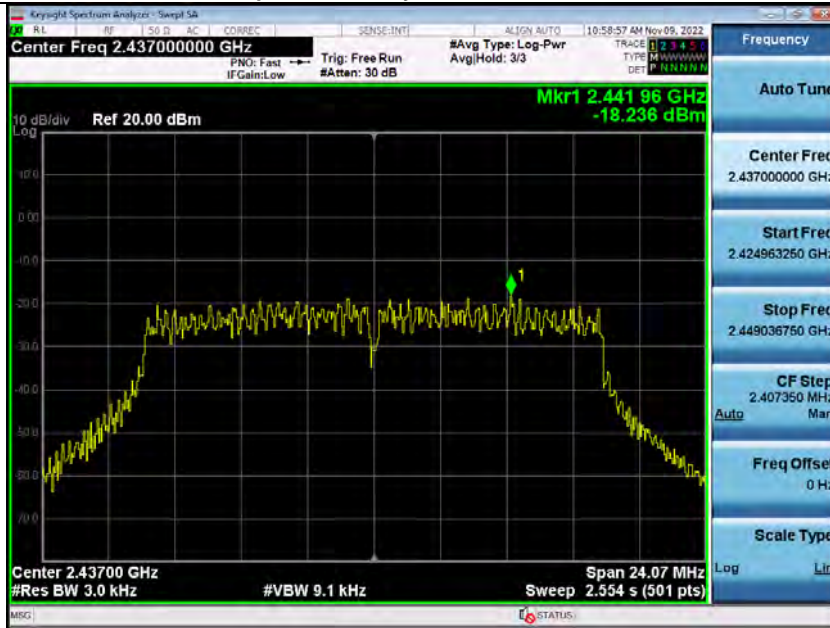

Power_Spectral_Density_2_4WiFi_2462_00-ANT1

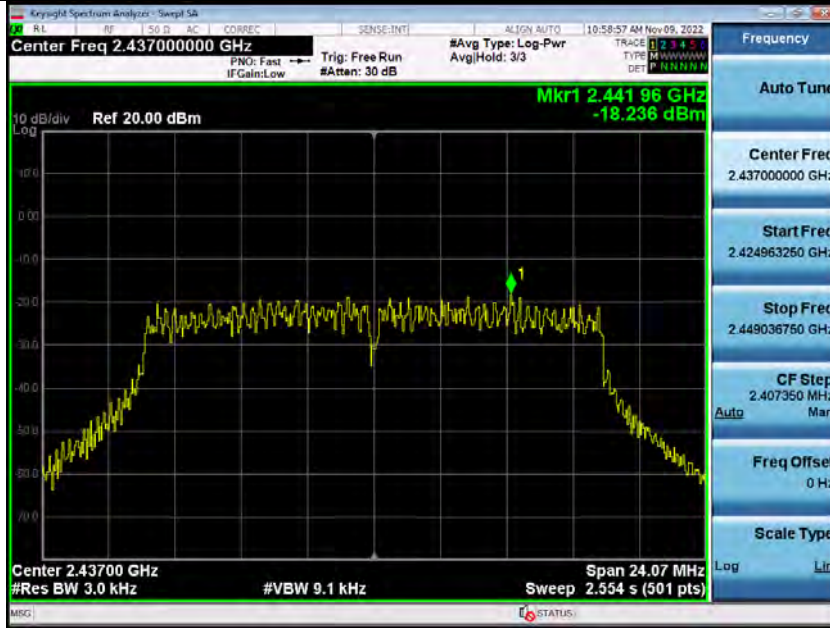

Power_Spectral_Density_2_4WiFi_2412_00-ANT1



Power_Spectral_Density_2_4GWiFi_2437_00-ANT1



Power_Spectral_Density_2_4GWiFi_2462_00-ANT1



Power_Spectral_Density_2_4WiFi_2422_00-ANT1



Power_Spectral_Density_2_4WiFi_2437_00-ANT1

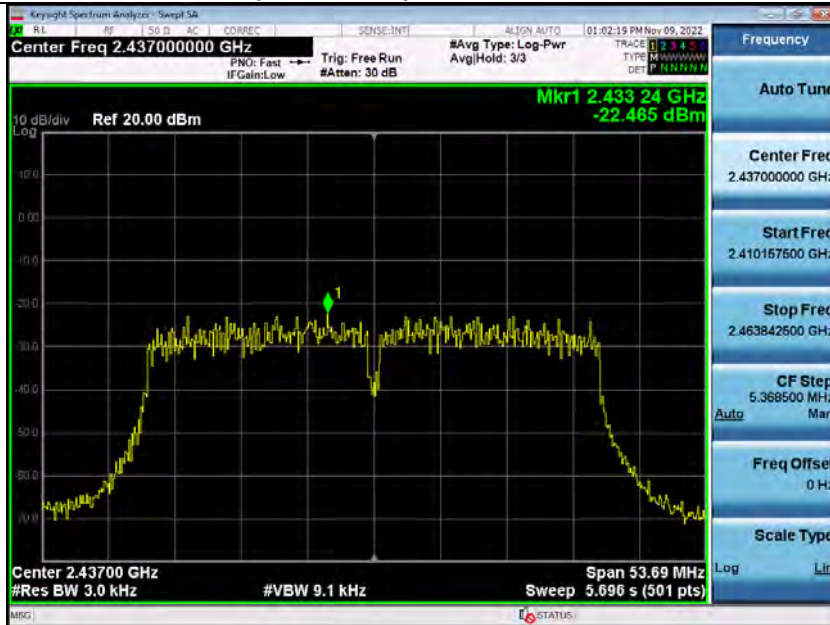

Power_Spectral_Density_2_4GWiFi_2452_00-ANT1

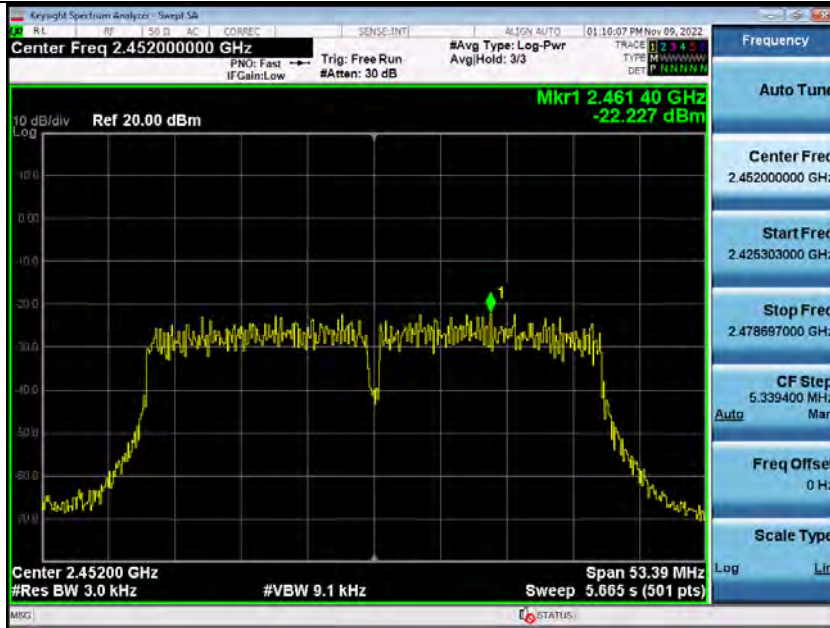

Power_Spectral_Density_2_4GWiFi_2412_00-ANT2



Power_Spectral_Density_2_4WiFi_2437_00-ANT2



Power_Spectral_Density_2_4WiFi_2462_00-ANT2

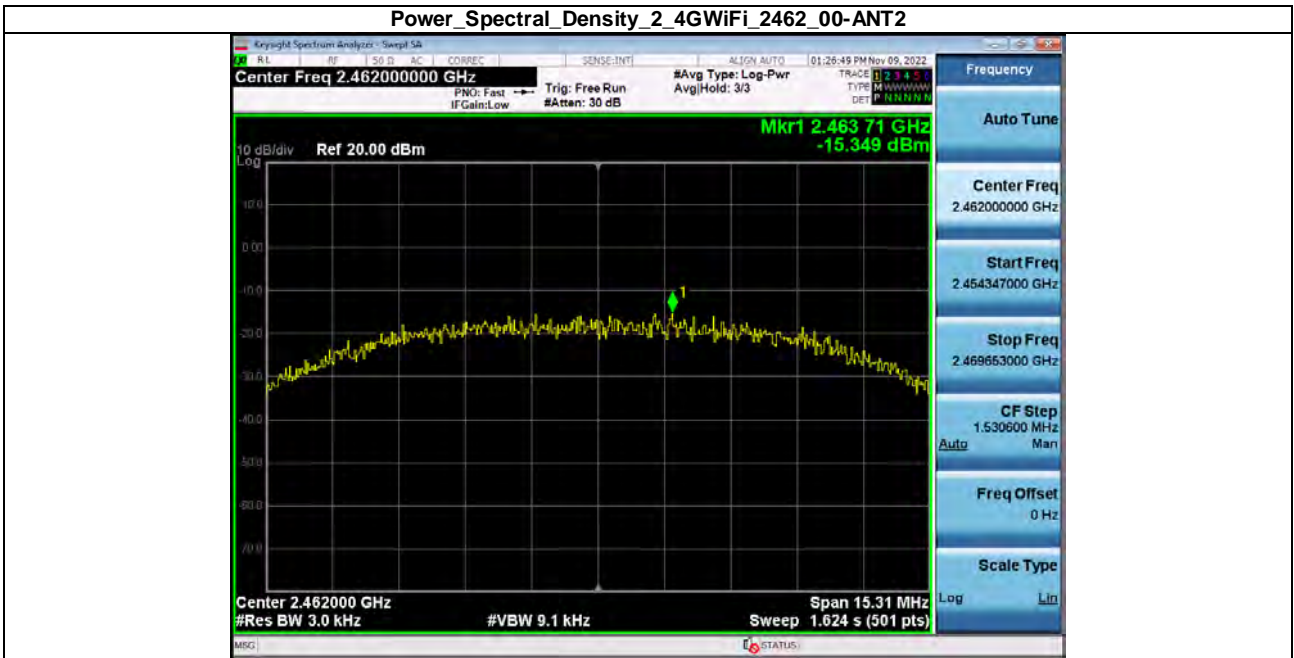

Power_Spectral_Density_2_4WiFi_2412_00-ANT2

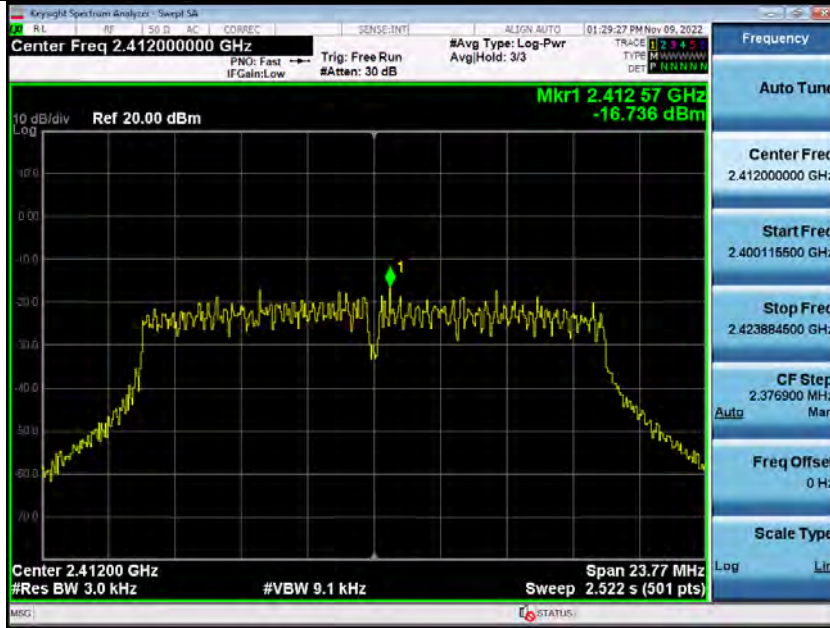

Power_Spectral_Density_2_4WiFi_2437_00-ANT2



Power_Spectral_Density_2_4WiFi_2462_00-ANT2



Power_Spectral_Density_2_4WiFi_2412_00-ANT2

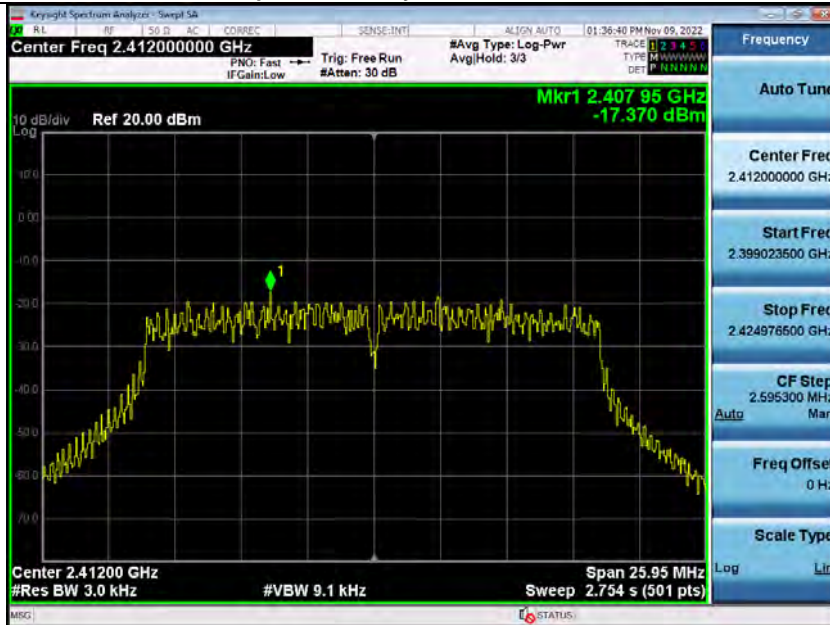

Power_Spectral_Density_2_4WiFi_2437_00-ANT2

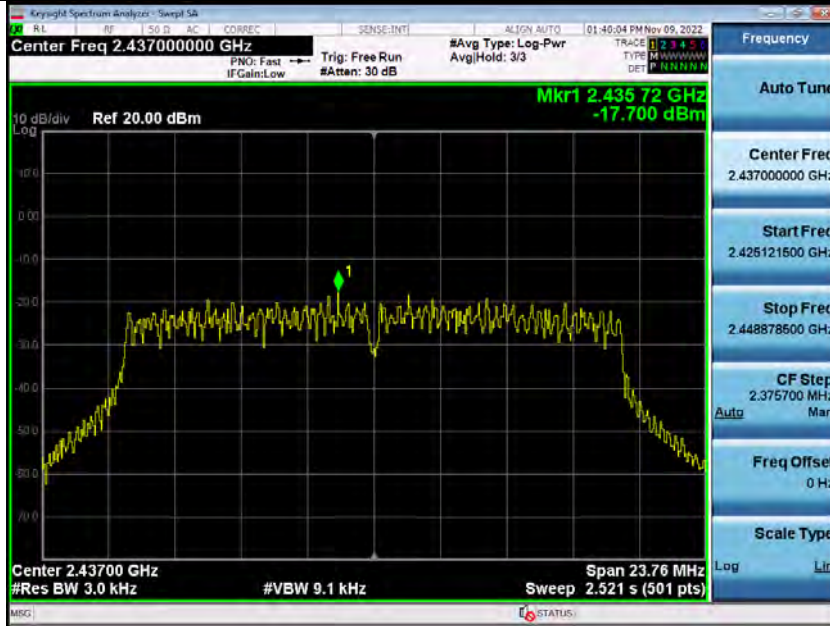

Power_Spectral_Density_2_4WiFi_2462_00-ANT2



Power_Spectral_Density_2_4WiFi_2422_00-ANT2



Power_Spectral_Density_2_4WiFi_2437_00-ANT2

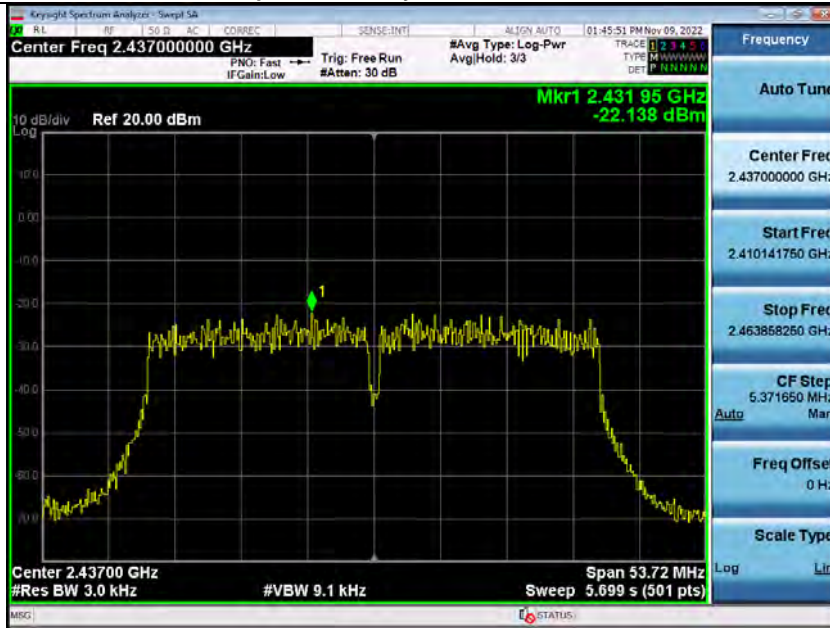

Power_Spectral_Density_2_4WiFi_2452_00-ANT2

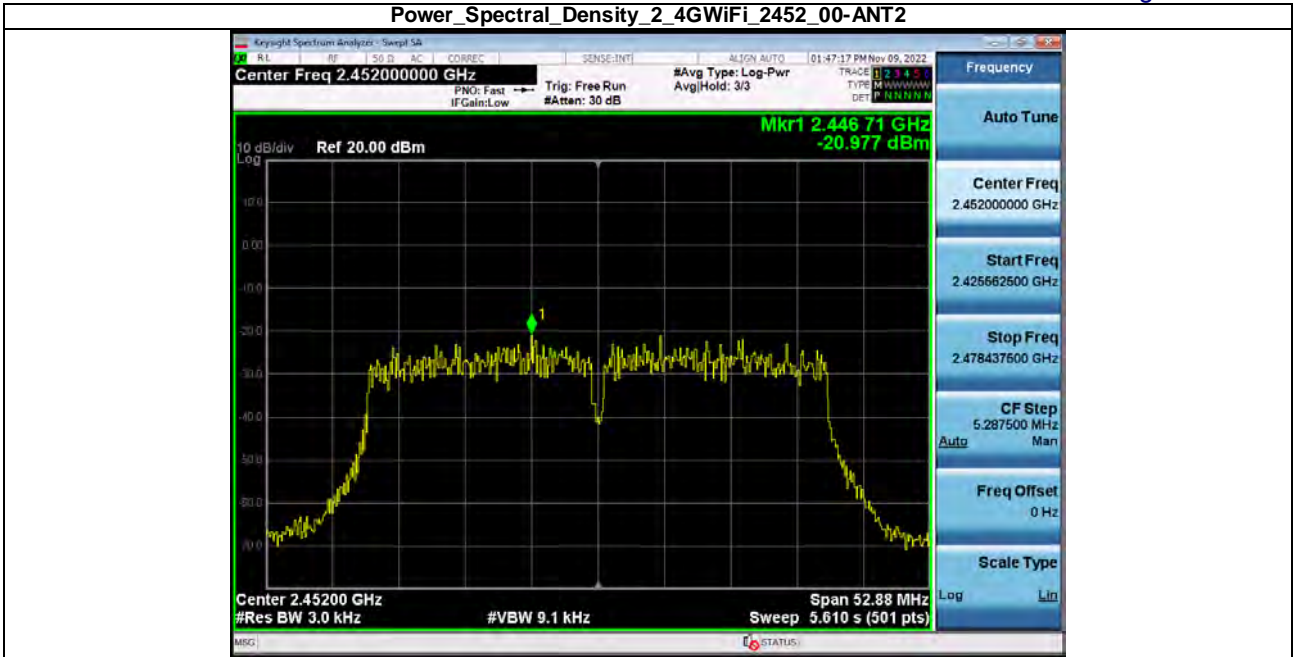

1_Reference_Level_2_4WiFi_2437_00-ANT1

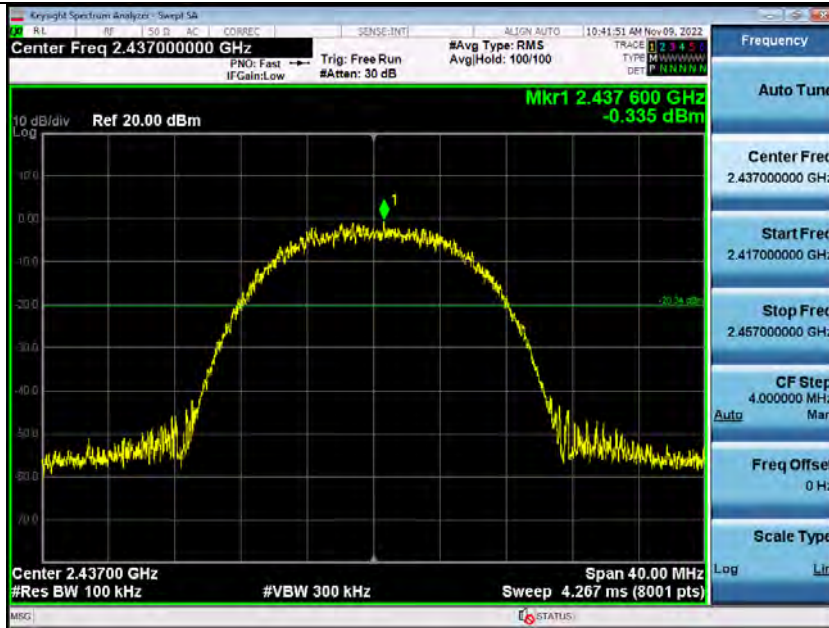

2_Spurious_Emission_2_4WiFi_NVNT_ANT1_802_11b_2437_00-ANT1

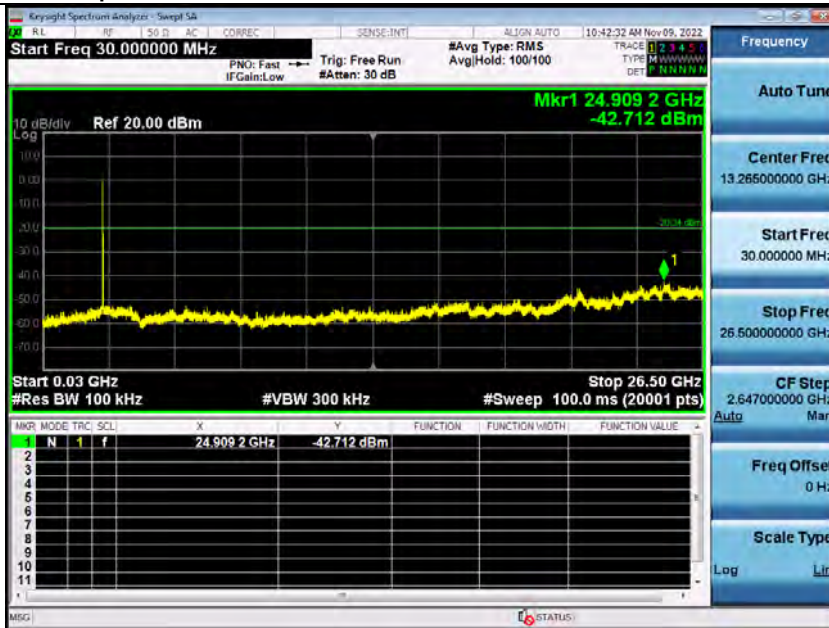

1_Reference_Level_2_4WiFi_2437_00-ANT1

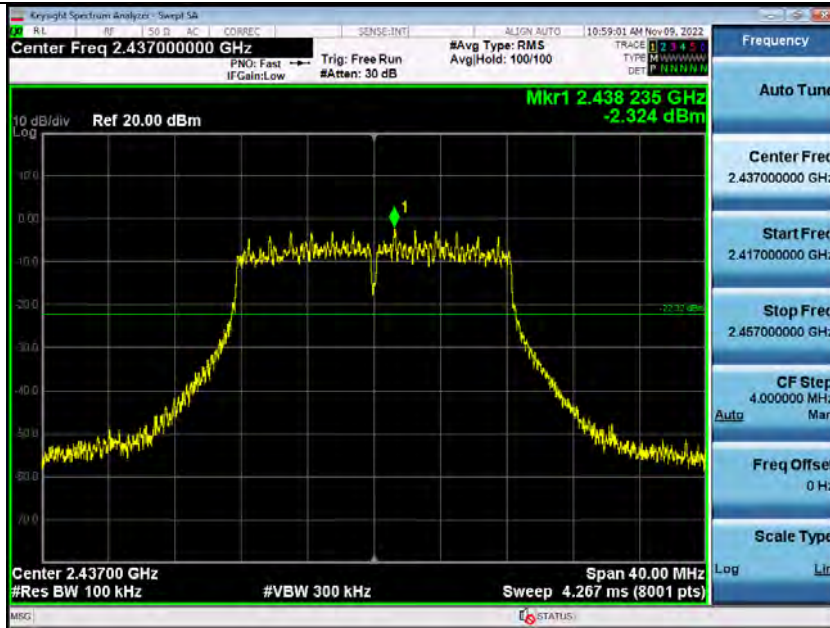

2_Spurious_Emission_2_4WiFi_NVNT_ANT1_802_11g_2437_00-ANT1

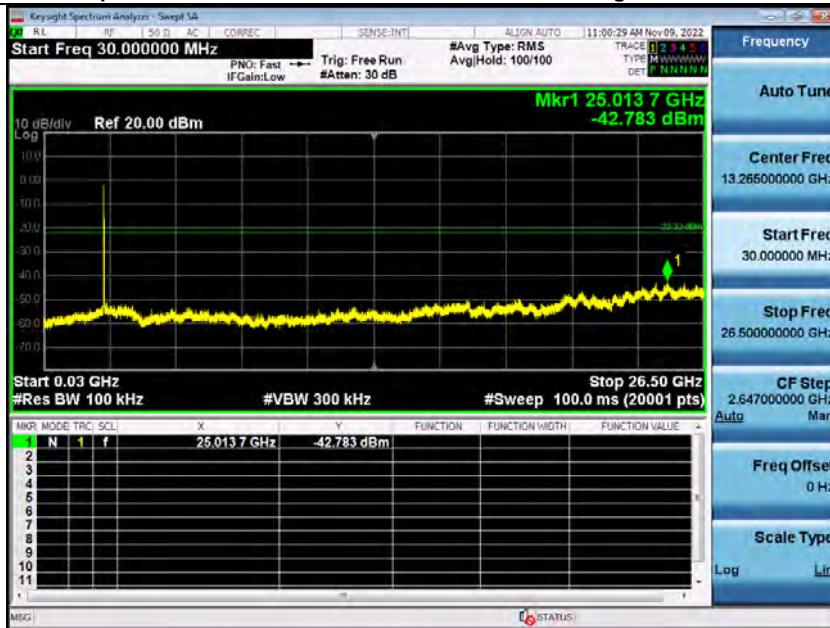

1_Reference_Level_2_4WiFi_2422_00-ANT1



2_Spurious_Emission_2_4WiFi_NVNT_ANT1_802_11n(HT40)_2422_00-ANT1

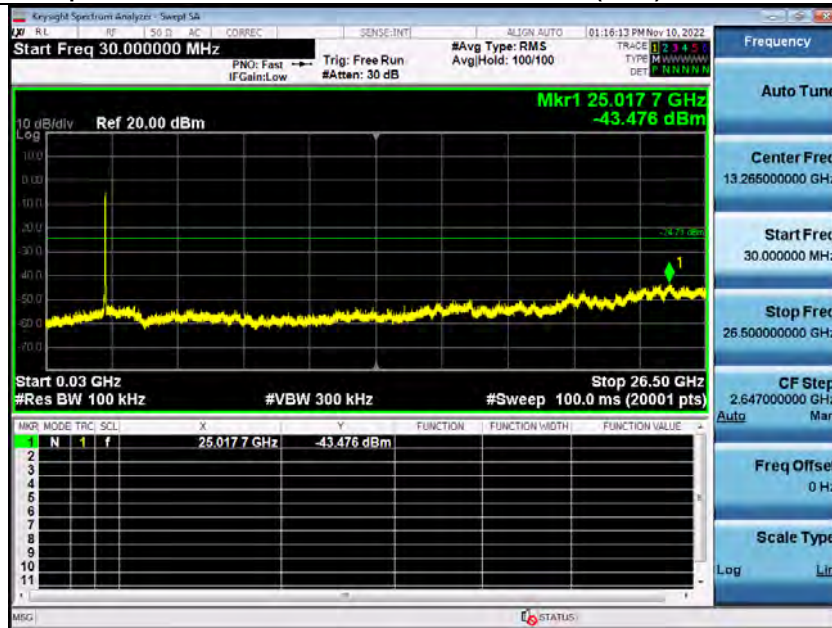

1_Reference_Level_2_4WiFi_2437_00-ANT1



2_Spurious_Emission_2_4WiFi_NVNT_ANT1_802_11n(HT40)_2437_00-ANT1

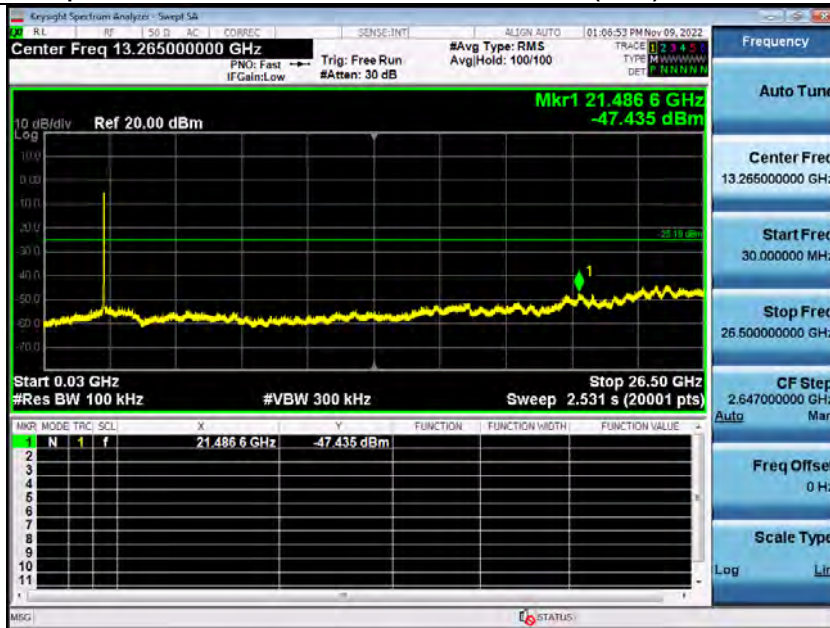

1_Reference_Level_2_4GWiFi_2452_00-ANT1

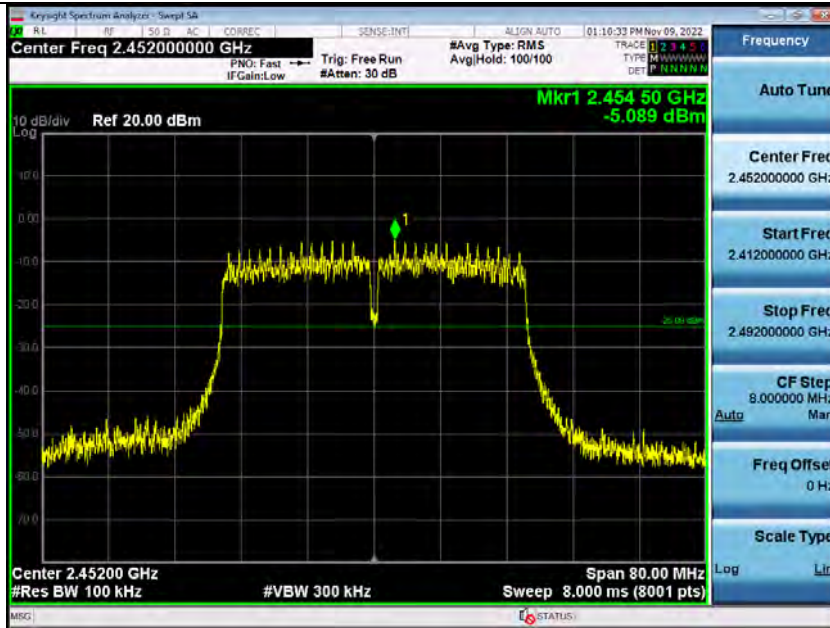

2_Spurious_Emission_2_4GWiFi_NVNT_ANT1_802_11n(HT40)_2452_00-ANT1

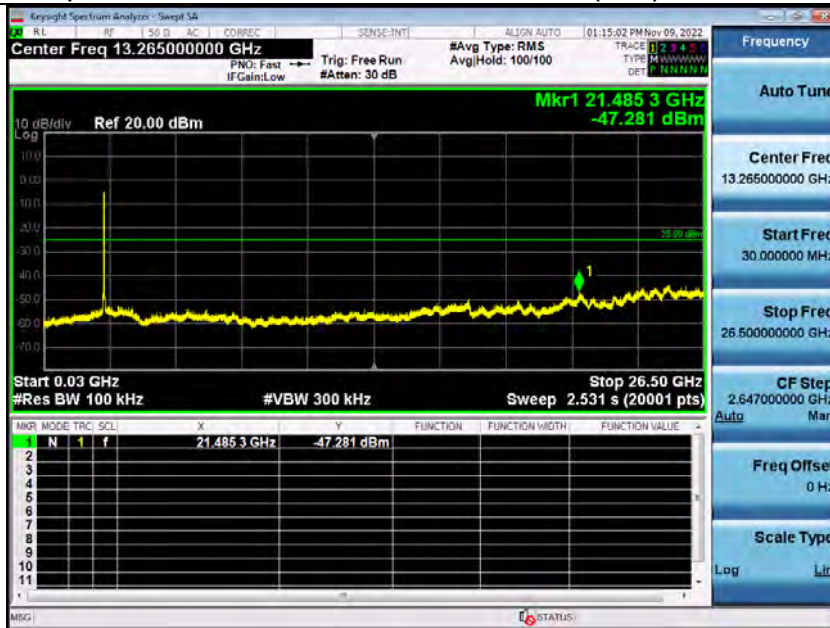

1_Reference_Level_2_4GWiFi_2412_00-ANT2

1_Reference_Level_2_4WiFi_2412_00-ANT2

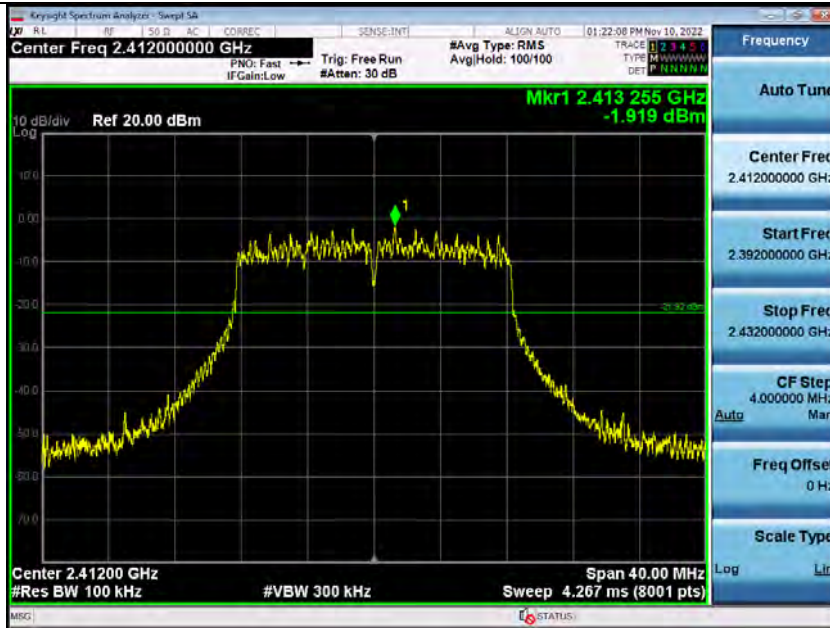

2_Spurious_Emission_2_4WiFi_NVNT_ANT2_802_11g_2412_00-ANT2

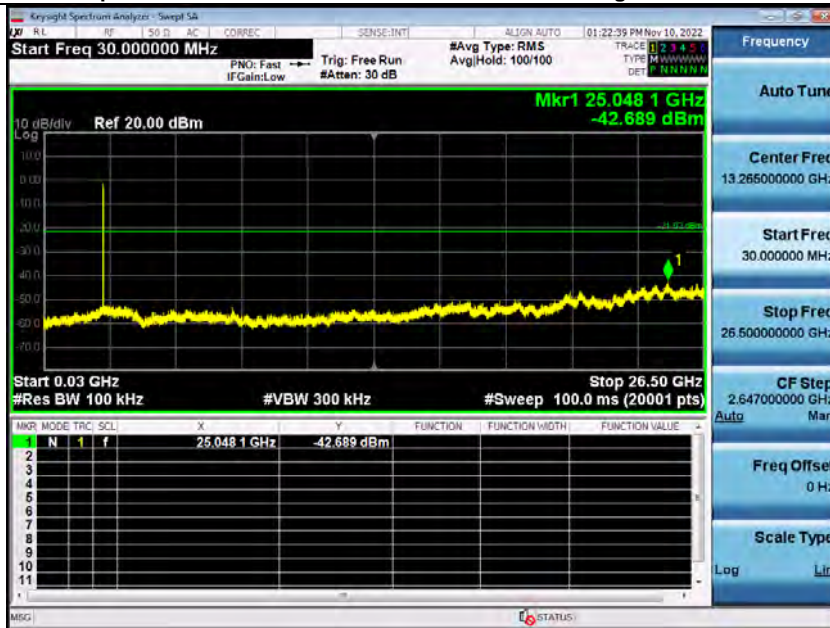

1_Reference_Level_2_4WiFi_2412_00-ANT2

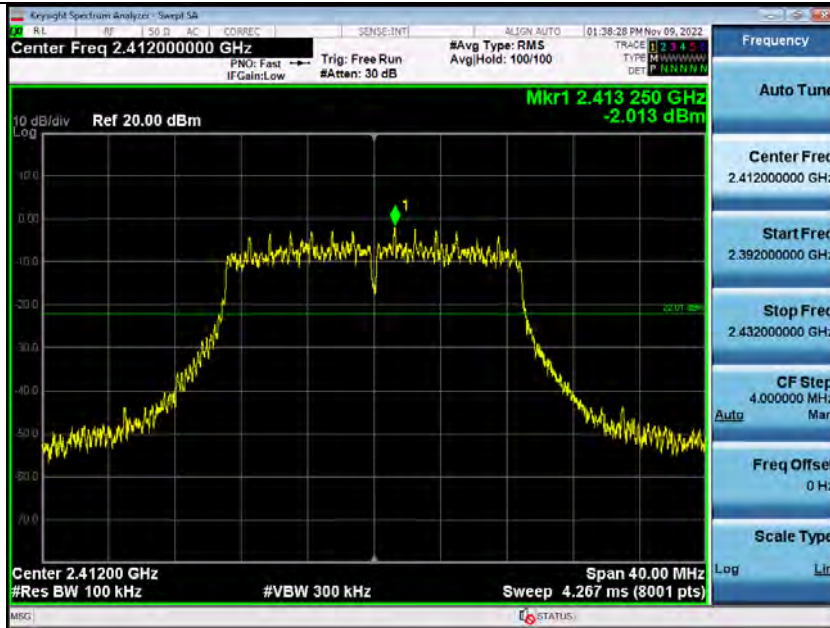

2_Spurious_Emission_2_4WiFi_NVNT_ANT2_802_11n(HT20)_2412_00-ANT2

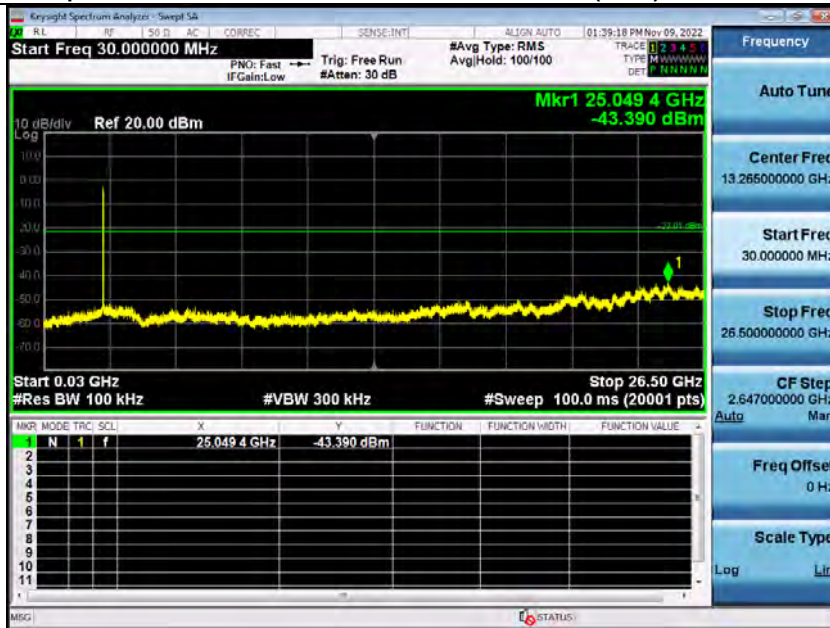

12. TEST SETUP PHOTO

Reference to the Test setup file for details.

13. EUT CONSTRUCTIONAL DETAILS

Reference to the external photos file and internal photos file for details.

******* END OF REPORT *******