

## *BTR-800, TR-800, TR-825 Professional Wireless Intercom System*

### *Operating Instructions*





# Table of Contents

<b>INTRODUCTION</b> .....	7	Portable Station Connect .....	38
General Description .....	7	Intercom A and B .....	38
System Features .....	7	Auxiliary .....	38
		Display Contrast .....	39
<b>BTR-800 BASE STATION</b> .....	<b>9</b>	BTR-800 Menu Structure .....	40
Controls and Connections – Front Panel .....	9	Main Screen Flowchart .....	40
BTR-800 Specifications .....	11	Power-Up Screen .....	41
		Operating Screen .....	41
<b>TR-800 BELTPACK</b> .....	<b>13</b>	Beltpack Activity Code Definitions .....	42
Controls and Connections – Top Panel .....	13	Group/Channel Select .....	43
TR-800 Specifications .....	15	Group/Frequency Select .....	44
		Frequency Edit (User-Programmed Groups Only) .....	45
<b>TR-825 BELTPACK</b> .....	<b>17</b>	ClearScan™ .....	46
Controls and Connections – Top Panel .....	17	Special Key Sequences .....	47
TR-825 Specifications .....	19	Lockout .....	47
		Copy .....	47
<b>INITIAL EQUIPMENT SETUP</b> .....	<b>21</b>	1st Use Default .....	47
Unpacking .....	21	Factory Default .....	47
Antenna Connection .....	22	Beltpack Operation .....	48
Antenna Polarization .....	22	On/Off and Volume Control .....	48
Distance between Antennas .....	22	Battery Check .....	48
Antenna Placement .....	22	Talk Button .....	48
Improving Reception and Increasing Range .....	24	Microphone Gain .....	48
Base Station Set-up .....	25	Audio Channel Select Button .....	48
Location .....	25	Stage Announce (SA) .....	48
Power Connection .....	25	Wireless Talk Around (WTA) .....	48
Transmit Switches .....	25	TR-800 Menu Structure .....	49
Internal Transmit Switches .....	26	Beltpack Menu Structure .....	49
Intercom Switch .....	26	Power-Up Screens .....	50
Intercom Interface .....	26	Group/Channel Screen .....	51
Dual Listen Functionality .....	28	Transmit Screen .....	52
Auxiliary Input/Output .....	29	Receive 1 Screen .....	53
Internal Auxiliary Input Routing Switch .....	29	Receive 2 Screen .....	54
Stage Announce / Relay Contacts .....	30	ClearScan™ .....	55
Base Station Link .....	31	Stage Announce Enable/Disable .....	56
Beltpack Setup .....	32	Wireless Talk Around Enable/Disable .....	56
Antenna Connection .....	33	Audio Channel A or B Disable/Enable .....	57
Transmit Mode .....	33	Talk Button Latch on/Latch off .....	57
Headset Connection .....	33	Special Key Sequences .....	58
		Lockout .....	58
<b>PRE-WALK-THRU CHECKLIST</b> .....	<b>35</b>	1st Use Default .....	58
		Factory Default .....	58
<b>SYSTEM OPERATION</b> .....	<b>37</b>	TR-825 Menu Structure .....	59
Frequency Plan Overview .....	37	Beltpack Menu Structure .....	59
Factory-Defined Groups .....	37	Power-Up Screens .....	60
User-Programmable Groups .....	37	Group/Channel Screen .....	61
System Quick Start .....	37	Transmit Screen .....	62
Base Station Operation .....	38	Receive 1 Screen .....	63
Power .....	38	Receive 2 Screen .....	64
Local Headset .....	38	Audio Output .....	65
		ClearScan™ .....	66
		Stage Announce Enable/Disable .....	67

---

Wireless Talk Around .....	68
Audio Channel A Options .....	69
Audio Channel B Options .....	70
Special Key Sequences .....	71
Lockout .....	71
1st Use Default .....	71
Factory Default .....	71
<b><i>SYSTEM WALK-THRU</i></b> .....	<b>73</b>
<b><i>TROUBLESHOOTING</i></b> .....	<b>75</b>
<b><i>TECH TIPS</i></b> .....	<b>77</b>
Frequency Interaction .....	77
Microphone Gain Adjustment .....	77
<b><i>BATTERY INFORMATION</i></b> .....	<b>79</b>
Cold Temperatures and Batteries .....	79
Battery Life: .....	79
Battery Warnings .....	79
<b><i>INTERCOM SYSTEMS</i></b>	
<b><i>SPECIFICATIONS</i></b> .....	<b>81</b>
<b><i>ACCESSORIES AND REPLACEMENT</i></b>	
<b><i>PARTS</i></b> .....	<b>83</b>
<b><i>CERTIFICATION INFORMATION</i></b> .....	<b>87</b>
<b><i>THREE BAND BASE STATIONS</i></b> .....	<b>89</b>
Identifying a Three Band Unit .....	89
Regulatory Changes and the Three Band .....	89
Changing Channel Maps .....	89

---

### *General Description*

The RTS BTR-800 UHF Synthesized Wireless intercom systems offer the ultimate in reliable, high performance, high-fidelity, full-duplex communications. The BTR-800 system includes the BTR-800 frequency agile base station, working with up to four TR-800 or TR-825 frequency agile beltpacks. The BTR-800 base station provides full-duplex communications with the beltpacks.

The BTR system incorporates two audio channel operation, permitting the beltpack operator to choose between two separate audio channels of communications, with the base station tracking the beltpack selection. This allows the user the flexibility to create a party-line and a private line within the same beltpack.

The BTR-800 system is perfectly suited for stand-alone operation and also can interface with Audiocom (Telex), RTS TW, Clear-Com, as well as RTS Matrix systems and other 4-wire communications systems. In addition to the external intercom systems interfaces listed above, the system provides connections for auxiliary balanced audio input and output, as well as wireless talk-around (WTA) and stage announce (SA) features.

The RTS BTR series has been designed for reliable, efficient operation. Operating in the 470 to 722 MHz range, the units operate reliably at line-of-sight distances of 1,000 feet. With available antenna systems, from Bosch, the effective operating range can be extended. The high efficiency beltpacks provide up to 12 hours of uninterrupted operation using standard alkaline batteries.

---

### *System Features*

- Frequency-agile base station and beltpacks. No external computer/device required to select frequencies.
- Backlit base-station LCD allows the user to easily monitor the beltpack's status as well as change base station frequencies.
- ClearScan™ function on base station and beltpack to automatically find the best channels on which to operate.
- Full-duplex (simultaneous talk and listen) operation.
- Compatible with Audiocom, RTS TW, Matrix, Clear-Com®, and other wired intercom types.
- Two channels of intercom audio.
- WTA (Wire less Talk Around) beltpack control. This feature allows beltpacks to talk to each other, but their audio is lifted from any wired system connected to the base station.
- SA (Stage Announce) beltpack control. Allows the user to direct their audio to a jack on the back of the base for P.A. systems or other external audio systems.
- Relay contact closure on the base when the SA button is pressed.
- TR-825 features two audio channel binaural operation in either stereo or mono mode.
- Beltpack units contained in a weather and shock resistant die-cast magnesium case.
- Convenient IEC power connector on the base station so the unit can plug directly to outlets. No in-line or wall plug power supply.
- Base station comes with rack ears for easy rack mounting.

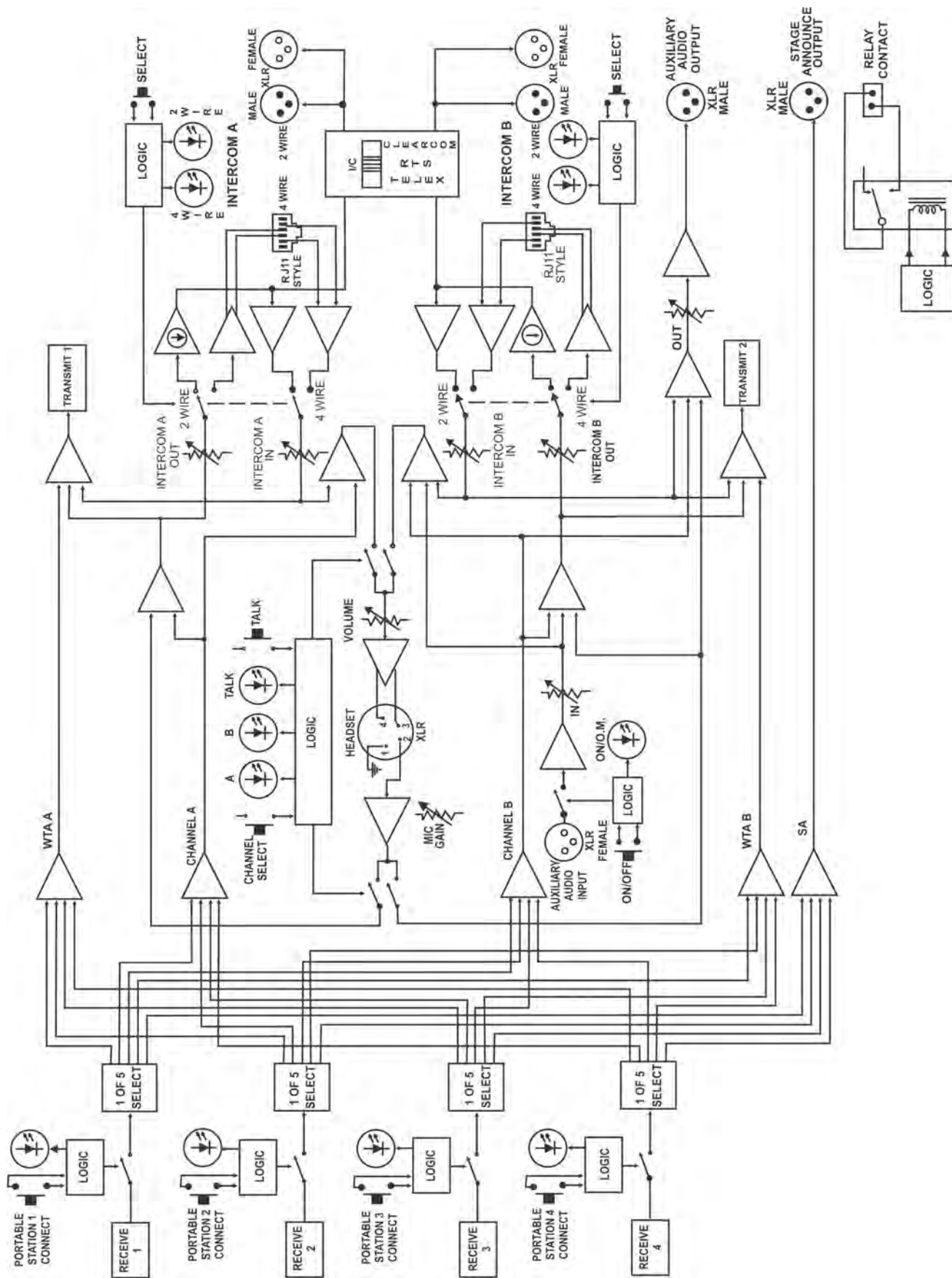
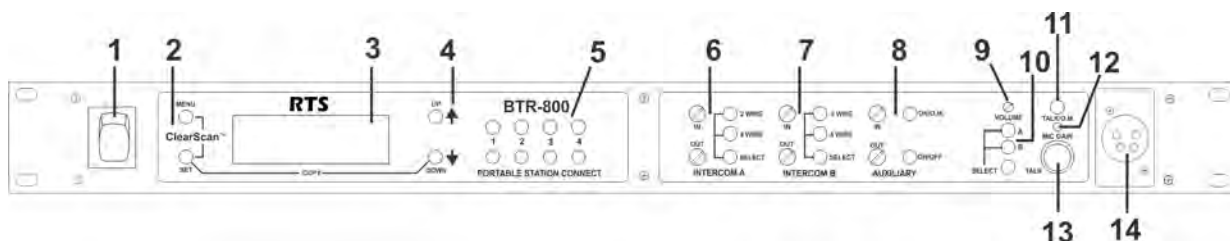


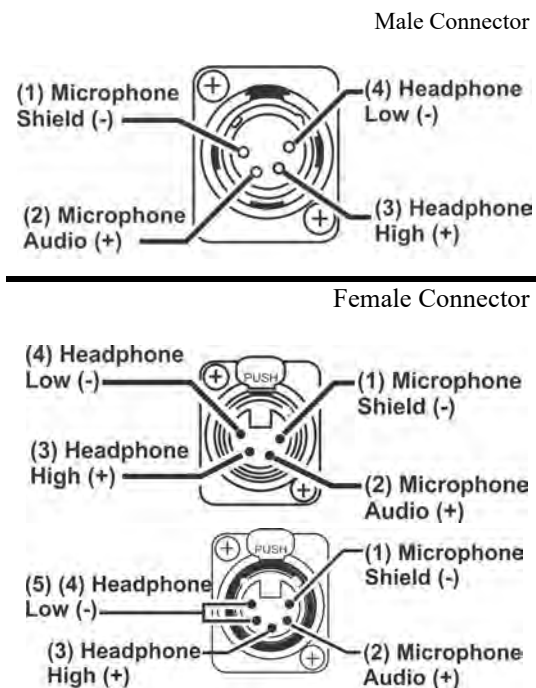
FIGURE 1. BTR-800 Block Diagram

*BTR-800 Base Station***Controls and Connections – Front Panel**

1. **Power Switch**
2. **[MENU] and [SET] buttons** - Use to select menus and set options on the LCD.
3. **Backlit Graphics LCD (Liquid Crystal Display)**
4. **[UP] and [DOWN] buttons** - Use to select base station options on the LCD.
5. **Portable Station Connect** - Use buttons to enable or disable the respective receiver's audio. GREEN LED - Audio enabled, LED OFF - Audio disabled.
6. **Intercom A Controls** – Wired intercom A interface controls. Audio input and output level controls. 2-wire or 4-wire select button with green LED indicator lights. Selected LED will change to RED if the input levels are too high.
7. **Intercom B Controls** – Wired intercom B interface controls. Audio input and output level controls. 2-wire or 4-wire select button with green LED indicator lights. Selected LED will change to RED if the input levels are too high.
8. **Auxiliary Controls** – Wired auxiliary interface controls. Audio input and output level controls. GREEN LED = Aux. input enabled. LED will change to RED if the input levels are too high.
9. **Headset Volume** – Controls the volume to the headset connection to #14.
10. **Headset Intercom Select** – Controls the intercom to which the local headset is connected. Each press of the button changes the connection; channel A, channel B, or both.
11. **Talk/Overmod Light** – LED is green when talk button #13 is active. A normal mic gain setting will cause the LED to flash red on the loudest speech levels. If the gain is too high, the LED is red at normal speech volumes.
12. **Microphone Gain** – Adjust the headset's microphone gain. Adjusts so that the overmod light #11 flashes from green to red on loudest speech.
13. **Talk Button** - Press to enable the audio path from the local handset. LED #11 turns green when enabled. A quick press and

release latches button on. If the talk function is latched on, pressing the talk button again turns it off.

14. **Local Headset Connector** - Male XLR connector or female XLR. A dynamic or electret headset microphone is automatically detected.



**FIGURE 2.**  
**Local Headset Wiring**

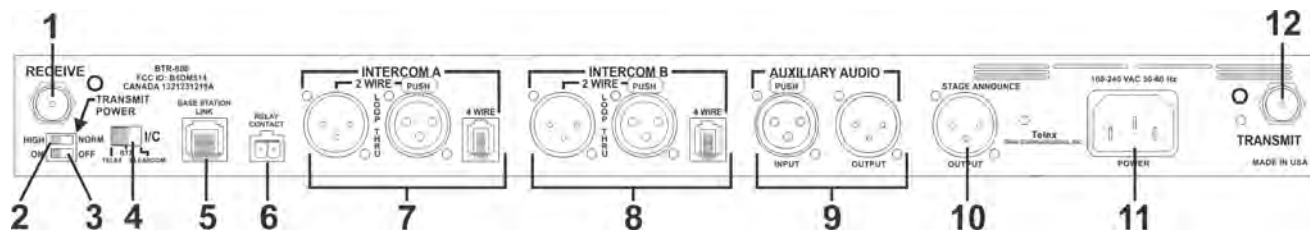


FIGURE 3.  
BTR-800 - Rear Panel

1. **Receive Antenna** – Female TNC Connector. Color band on antenna must match color dot on base station.
2. **Transmit Power Switch** – HIGH = Transmitters at full power. NORMAL = Transmitters 10dB below full power.
3. **Transmit ON/OFF Switch** – Turns the transmitters on or off.
4. **I/C Select Switch** – Set to the appropriate 2-wire intercom type being interfaced to the unit. Set to either Telex, RTS, or Clear-Com.
5. **Base Station Link Jack** – When two base stations are connected through this jack, it allows wireless talk around (WTA) from the beltpacks to be routed from the system with it's transmitters off to the system with it's transmitters on.
6. **Relay Contact** – A dry contact closure which is activated when a beltpack user presses the stage announce (SA) button. Normally Open (NO). 1 Amp at 24V maximum.
7. **Intercom A** – Interface to wired intercom system A. 2-Wire – Male and female 3-pin XLR connectors wired in parallel. The connectors are switched to the appropriate intercom configuration via the I/C Select Switch. 4-Wire – An RJ-11 type jack compatible with Matrix type intercom systems.
8. **Intercom B** – Interface to wired intercom system B. 2-Wire – Male and female 3-pin XLR connectors wired in parallel. The connectors are switched to the appropriate intercom configuration via the I/C Select Switch.
9. **Auxiliary Input/Output** – One 3-pin female XLR input connector and one 3-pin male XLR output connector.
10. **Stage Announce Output** – Passes the audio from any of the base stations's beltpack that have selected stage announce (SA).
11. **Power** – IEC receptacle. Accepts 100–240 VAC, 50–60 Hz.
12. **Transmit Antenna** – Female TNC Connector. Color band on antenna must match color dot on base station.

---

**WARNING:** Excessive current through the loop thru ports will damage the intercom! Do not exceed 200 mA current in the 2-wire loop thru circuits.

---



---

**WARNING:** Excessive current through the loop thru ports will damage the intercom! Do not exceed 200 mA current in the 2-wire loop thru circuits.

---

4-Wire – An RJ-11 type jack compatible with Matrix type intercom systems.



**BTR-800 Specifications**

<b>Overall</b>	
RF Frequency Range	Internally Adjustable (2 Vrms typical at rated deviation into 600Ω)
TX Range	Stage Announce Relay
482-608 MHz in 18 MHz TX bands	Dry contact, rated at 1 Amp, 24V Max
US/Canada RX Range	Microphone input sensitivity
572-608 MHz in 18 MHz RX bands	9mV
653-663 MHz for 3 band	Local Headset Output
470-488 MHz for 88 band	40mW output into 600Ω (1% Distortion)
Rest of the World RX Range	<b>Transmitter</b>
572-608, 614-722 MHz in 18 MHz RX bands	Type
Power Requirements	Two Synthesized Transmitters
100-240 VAC, 50-60 Hz, IEC receptacle	Transmit Power (each transmitter)
Temperature Range	100 mW Max (High), 10 mW (Normal)
-4° F - 130° F (-20° C to 55° C)	Modulation Type
Dimensions	FM
19.00" W x 1.72" H x 14.00" D	Deviation
(48.3 cm x 4.4 cm x 35.6 cm)	40 kHz
Weight	RF Frequency Stability
7 lbs x2 oz (3.24 kg)	0.005%
TX Antenna	Modulation Limiter
1/2 Wave (supplied), TNC Male Connector	Peak-Responding Compressor
RX Antenna	Radiated Harmonics & Spurious
1/2 Wave (supplied), TNC Male Connector	Exceeds FCC specifications
FCC ID	<b>Receiver</b>
B5DM529	Type
B5DM514	Dual Conversion Superheterodyne, four Independent Synthesized IFs, FM
Frequency Response	RF Sensitivity
300 Hz - 8 kHz	<0.8 μV for 12 dB SINAD
Four Wire Input	Squelch Threshold
Level Adjustable (2 Vrms typical)	20 dB SINAD
Four Wire Output	IF Selectivity
Level Adjustable (2 Vrms typical)	3 dB at 230 kHz
Telex Intercom	Image Rejection
Input/Output Level Adjustable (1 Vrms typical), Line Impedance 300Ω	70 dB or better
RTS Intercom	Squelch Quieting
Input/Output Level Adjustable (0.775 Vrms typical), Line Impedance 200Ω	90 dB
Clear-Com Intercom	RF Frequency Stability
Input/Output Level Adjustable (1 Vrms typical), Line Impedance 200Ω	0.005%
Auxiliary Input	Distortion
Adjustable (2 Vrms typical)	<1% at full deviation
Auxiliary Output	
Adjustable (2 Vrms typical into 600Ω)	
Stage Announce Output	



*TR-800 Beltpack*

## Controls and Connections – Top Panel

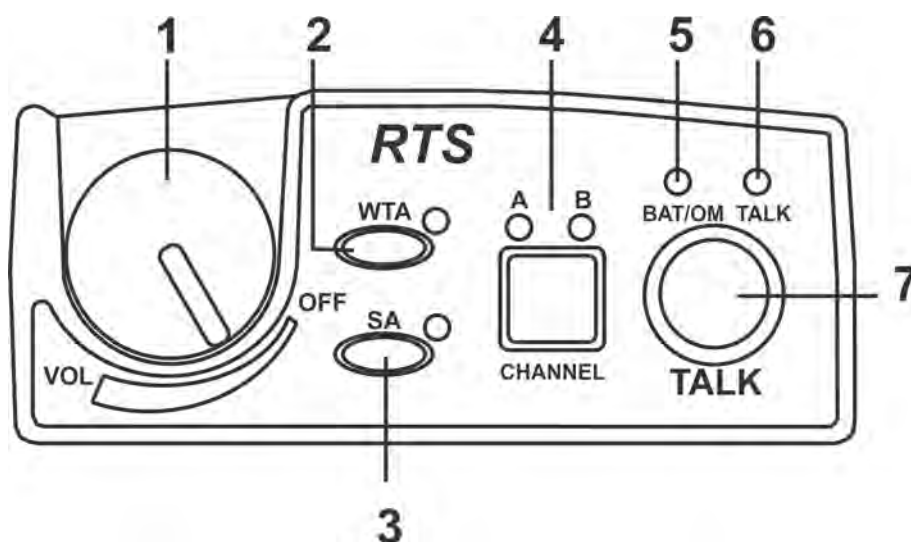
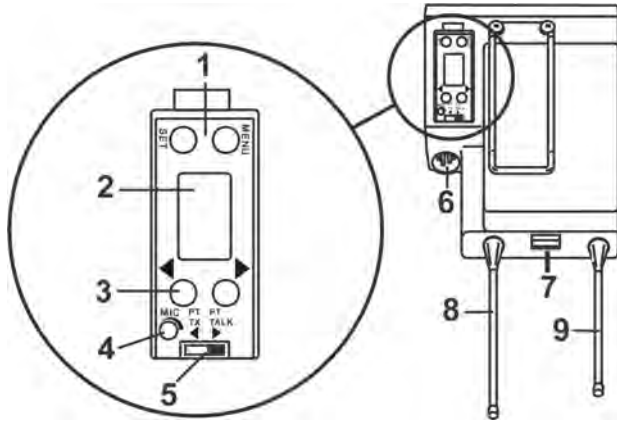


FIGURE 4.  
TR-800 Top Panel

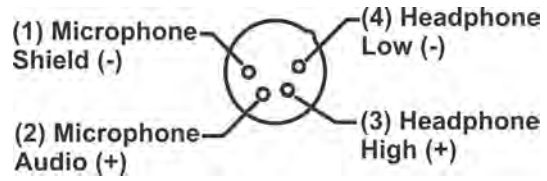
- On/Off & Volume Control** – Turns the beltpack power on and controls headset volume.
- Wireless Talk Around (WTA)** – When pressed, the user's audio is disconnected from the wired intercom, auxiliary input/output and the base station's local headset. Other beltpack users, on that audio channel, can hear the user as normal. The button activates the nearby red LED as well as the Talk LED, #6, when pressed.
- Stage Announce (SA)** – When pressed, the user's audio is routed to the stage announce connector on the back of the base station. The user also loses their sidetone as an indication that stage announce is activated. The other wireless beltpacks and wired users do not hear the user's audio. The button is non-latching and activates the nearby red LED as well as the TALK LED, #6, when pressed.
- Audio Channel Selection Button** – Allows user to select either audio channel A or B.
- Bat/Overmod Light (BAT/OM)** – Light will flash once when unit is turned on if the battery is good. If the light stays on, battery is low. If the light does not flash, battery is dead. A normal microphone gain setting will cause the LED to flash at the beginning of most words at normal speech levels. If the gain is too high, the LED will be red during the complete word at normal speech levels.
- Talk Light** – LED is on when the talk button, SA or WTA is active.
- Talk Button** – Press to enable the audio path from the local headset microphone. The TALK LED, #6, will turn red when enabled. A quick press and release latches the talk function, unless latching has been disabled. Holding the button for over 1/2 a second will cause the audio path to be enabled only for as long as the button is held. If the talk function is latched on, pressing the talk button again will turn it off.



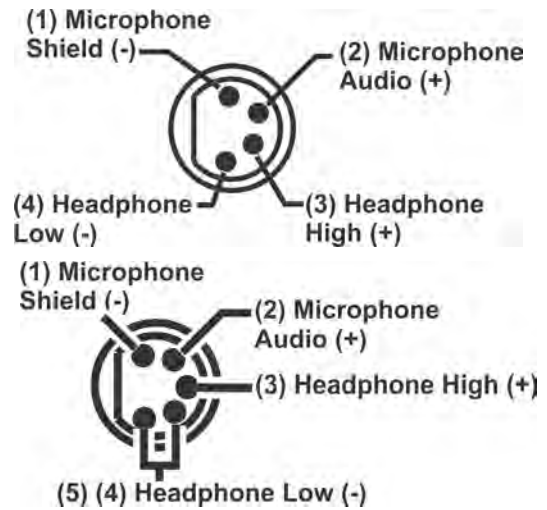
**FIGURE 5.**  
**TR-800 Rear Panel/Connector/Antennas**

1. **[MENU] and [SET] buttons** – Used to select menus and set option on the LCD
2. **LCD (Liquid Crystal Display)**
3. **[UP] and [DOWN] buttons** – Used to select beltpack options on the LCD.
4. **Microphone Gain** – Adjusts the headset’s microphone gain. Adjust so that the BAT/OM LED will flash at the beginning of most words at normal speech levels.
5. **Push-to-Talk/ Push-to-Transmit Switch** –  
Push-to-Talk (PT TALK) – The transmitter is always on. No audio set unless the talk switch, WTA or SA button pressed. Recommended position.  
  
Push-to-Transmit (PT TX) – The transmitter and audio path are off except when the talk switch, WTA or SA, button is pressed.
6. **Headset Connector** – Male XLR connector or female XLR connector. A dynamic or electret headset microphone is automatically detected by the beltpack and a bias voltage supplied, if needed.

Male Connector



Female Connector



**FIGURE 6.**  
**Headset Jack Wiring**

7. **Battery Latch** – Press down to enable the battery pack to be released. While the latch is held down, slide the battery pack about 1/8 inch back, toward the latch, until it stops. Then lift it out.
8. **Receive Antenna** – Screw type 1/4-wave replaceable antenna. The color dot on the screw end of the antenna must match color dot on antenna receptacle.
9. **Transmit Antenna** – Screw type 1/4-wave replaceable antenna. The color dot on the screw end of the antenna must match color dot on antenna receptacle.

**TR-800 Specifications**

## RF Frequency Range

## US/Canada TX Range

572-608 MHz in 18 MHz TX bands  
 653-663 MHz for 3 bands  
 470-488 MHz for 88 band

## Rest of World TX Range

572-608, 614-722 MHz in 18 MHz TX bands

## RX Range

482-608 MHz in 18 MHz RX bands

## Power Requirements

6 AA Cells Alkaline (NiMH optional)

## Current Draw

140 mA (Push-to-Talk, Talk On)

## Temperature Range

-4° F to 130° F (-20° C to 55° C)

## Dimensions

3.75" W x 5.05" H x 1.65" D  
 (9.5 cm x 12.8 cm x 4.2 cm)

## Weight

16 oz (454 g) with alkaline batteries

## TX Antenna

1/4 Wave (supplied), Screw type, Replaceable

## RX Antenna

1/4 Wave (supplied), Screw type, Replaceable

## FCC ID

B5DM518  
 B5DM515  
 B5DM536

## Frequency Response

300 Hz - 8 kHz

## Microphone input sensitivity

7 mV

## Local Headset Output

40 mW output into 600Ω (1% distortion)

## RF Frequency Stability

0.005%

## Modulation Limiter

Peak-Responding Compressor

## Radiated Harmonics &amp; Spurious

Exceeds FCC specifications

**Receiver**

## Type

Dual Conversion Superheterodyne, Synthesized, FM

## RF Sensitivity

<0.7 μV for 12 dB SINAD

## Squelch Threshold

20 dB SINAD (about 1.0 μV)

## IF Selectivity

3 dB at 230 kHz

## Image Rejection

70 dB or better

## Squelch Quieting

90 dB

## RF Frequency Stability

0.005%

## Distortion

<1% at full deviation

**Transmitter**

## Type

Synthesized

## Transmit Power

50 mW Max (auto-power reduction)  
 20 mW Max in US 3 Band, 653-663 MHz, auto-power reduction

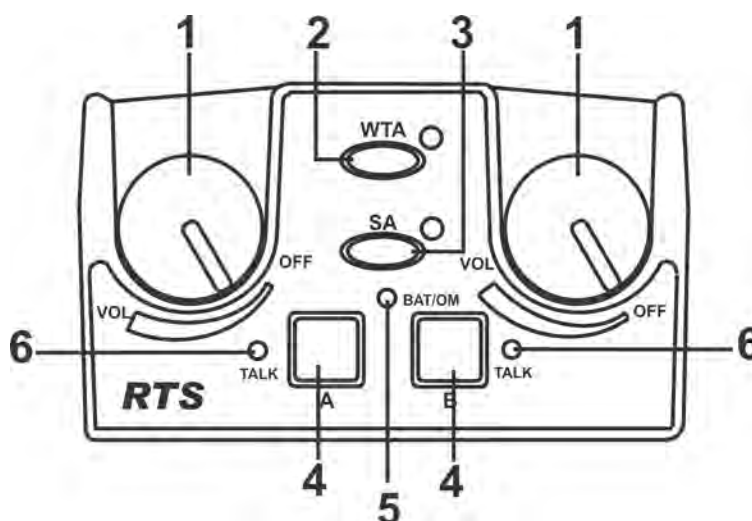
## Modulation Type

FM

## Deviation

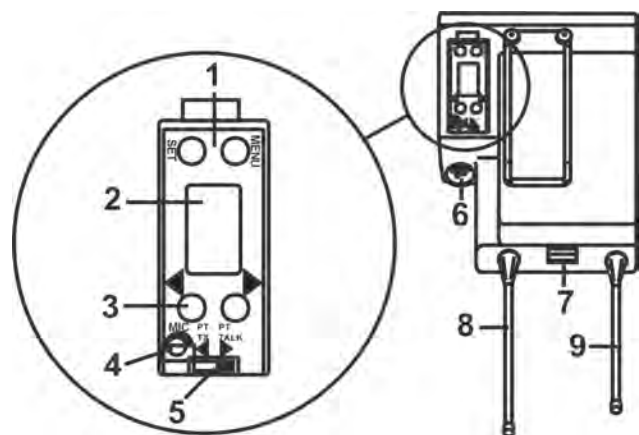
40 kHz



**Controls and Connections – Top Panel**

**FIGURE 7.**  
**TR-825 Top Panel**

- 1. On/Off and Volume Control** – Turns beltpack power on and controls headset volume for Intercom Channels A and B. Either knob, A or B, turns the beltpack on. Both knobs must be off to turn the beltpack off. If only one knob is off, then only that Intercom Channel, A or B, is off for both transmit and receive audio.
- 2. Wireless Talk Around (WTA)** – When pressed, the user's audio is disconnected from the wired intercom, auxiliary input/output and the base stations's local headset. Other beltpack users, on that audio channel, can hear the user as normal. The default setting is software selectable, as to which Intercom Channel, A, B, A+B, or currently selected channel, is activated along with the WTA button. The WTA button activates the nearby red LED as well as the software selected Intercom Channel TALK LED if not already active.
- 3. Stage Announce (SA)** – When pressed, the user's audio is routed to the stage announce connector on the back of the base station. The user also loses their sidetone as an indication that stage announce is activated. The other wireless beltpacks and wired users do not hear the user's audio. The button is non-latching and activates the nearby red LED.
- 4. Talk Button** – Press to enable the audio path to either Intercom Channel A or B or A+B, from the local headset microphone. The associated TALK LED, #6, will turn red when enabled. A quick press and release latches the talk function, unless latching has been disabled. Holding the button for over 1/2 second, will cause the audio path to be enabled only for as long as the button is held. If the talk function is latched on, pressing the talk button again will turn it off.
- 5. Low Battery/Overmodulation (BAT/OM) Light** – Light will flash once when unit is turned on if the battery is good. If the light stays on, battery is low, If the light does not flash, battery is dead. A normal microphone gain setting will cause the LED to flash at the beginning of most words at normal speech levels. If the gain is too high, the LED will be red during the complete word at normal speech levels.
- 6. Talk Light** – Will turn red when enabled by associated TALK or WTA button.



**FIGURE 8.**  
**TR-825 Rear Panel/Connector/Antennas**

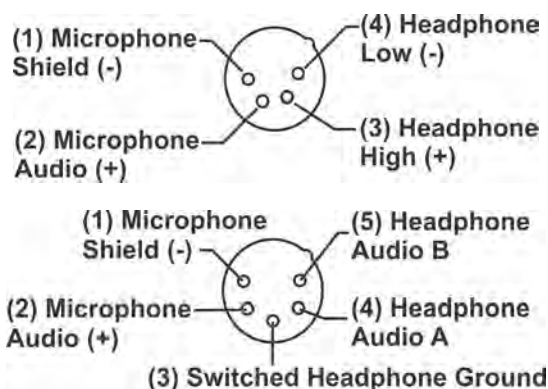
1. **[MENU] and [SET] buttons** – Used to select menus and set options on the LCD.
2. **LCD (Liquid Crystal Display)**
3. **[UP] and [DOWN] buttons** – Used to select beltpack options on the LCD.
4. **Microphone Gain** – Adjusts the headset's microphone gain. Adjust so that the BAT/OM LED will flash at the beginning of most words at normal speech levels.
5. **Push-to-Talk/Transmit Switch** – Push-to-Talk (PT TALK) - The transmitter is always on. No audio sent unless the talk switch, WTA, or SA button pressed. Recommended position.

Push-to-Transmit (PT TX) –The transmitter and audio path are off except when the talk switch, WTA, or SA button is pressed.

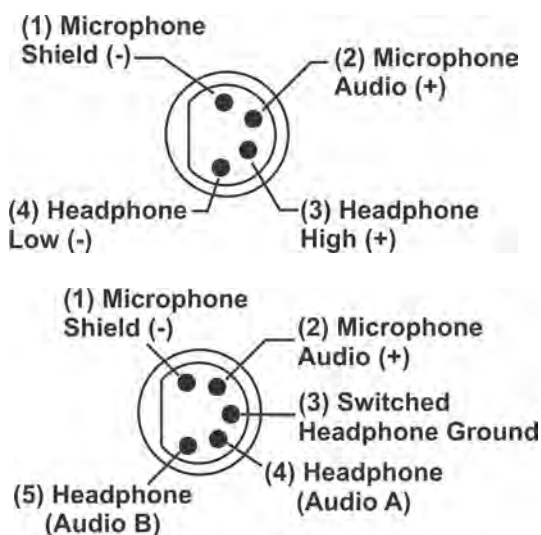
6. **Headset Connector** – Male XLR connector or female XLR connector. A dynamic or electret headset microphone is automatically detected by the beltpack and a bias voltage supplied, if needed. Four-pin units are monaural. Five pin units have a software setup which ground or opens pin 3.

Menu Set	PIN 3	RESULT ON 5-PIN DUAL HEADPHONE
[ Ab SEP ]	GND	A in one side, B in other side
[ Ab Add ]	OPEN	A + B

### Male Connector



### Female Connector



**FIGURE 9.**  
**Headset Jack Wiring**

Single-sided 5-pin headsets will only receive A or B, depending on how headphone is wired. These headsets must have the beltpack set for [Ab SEP]

7. **Battery Latch** – Press down to enable the battery pack to be released. While the latch is held down, slide the battery pack about 1/8-inch back, toward the latch, until it stops. Then lift out.
8. **Receive Antenna** – Screw type 1/4-wave replaceable antenna. The color dot on the screw end of the antenna must match color dot on antenna receptacle.
9. **Transmit Antenna** – Screw type 1/4-wave replaceable antenna. The color dot on the screw end of the antenna must match color dot on antenna receptacle.



**TR-825 Specifications**

## RF Frequency Range

## US/Canada TX Range

572-608 MHz in 18 MHz TX bands

653-663 MHz for 3 band

470-488 MHz for 88 band

## TX Range (rest of the world)

572-608, 614-722 MHz in 18 MHz TX bands

## RX Range

482-608 MHz in 18 MHz RX bands

## Power Requirements

6 AA Cells Alkaline (NiMH optional)

## Current Draw

190 mA (Push-to-Talk, A and B Talk On)

## Temperature Range

-4° F to 130° F (-20° C to 55° C)

## Dimensions

3.75" W x 5.35" H x 2.02" D

(9.5 cm x 13.5 cm x 5.1 cm)

## Weight

21 oz (595 g) with alkaline batteries

## TX Antenna

1/4 Wave (supplied), Screw type, Replaceable

## RX Antenna

1/4 Wave (supplied), Screw type, Replaceable

## FCC ID

B5DM517

B5DM537

## Frequency Response

300 Hz - 8 kHz

## Microphone input sensitivity

7 mV

## Local Headset Output

40 mW output into 600Ω (1% distortion)

## RF Frequency Stability

0.005%

## Modulation Limiter

Peak-Responding Compressor

## Radiated Harmonics &amp; Spurious

Exceeds FCC specifications

**Receiver**

## Type

Two, Dual Conversion Superheterodyne,  
Synthesized, FM

## RF Sensitivity

<0.8  $\mu$ V for 12 dB SINAD

## Squelch Threshold

20 dB SINAD (about 1.0  $\mu$ V)

## IF Selectivity

3 dB at 230 kHz

## Image Rejection

70 dB or better

## Squelch Quieting

90 dB

## RF Frequency Stability

0.005%

## Distortion

&lt;1% at full deviation

**Transmitter**

## Type

Synthesized

## Transmit Power

50 mW Max (auto-power reduction)

20 mW Max in US 3 Band, 653-663 MHz, (auto-  
power reduction)

## Modulation Type

FM

## Deviation

40 kHz



*Initial Equipment Setup***Unpacking**

Unpacking your RTS System. Below are the items that should come with your base station and each beltback.

Contact the shipper or your dealer immediately if anything is damaged or missing. Fill out the registration card and return it to Bosch to register the unit.

**BTR-800**

Quantity	Description
1	BTR-800 Base Station
1	Power Cord
2	Antennas (one Transmit and one Receive)
1	Warranty and Website Information Sheet
1	Screwdriver
1	2 terminal plug (for SA Relay)
1	Warning Card
4	Rubber Feet
1	Packing Checklist
1	Simplified Declaration of Conformity

**TR-800, TR-825**

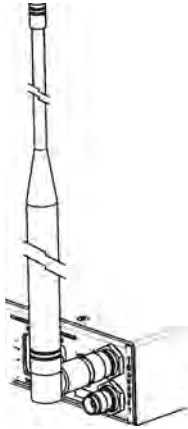
Quantity	Description
1	TR-8XX with Antennas
1	Battery pack
1	Instruction Sheet
1	Screwdriver
1	Warranty and Website Information Sheet
1	Packing Checklist
1	Simplified Declaration of Conformity for Non-US/Canada Units

## Antenna Connection

The base station is supplied with the two antennas. One 1/2-wave antenna for Transmit and one 1/2-wave for Receive. The antennas have TNC male connectors.

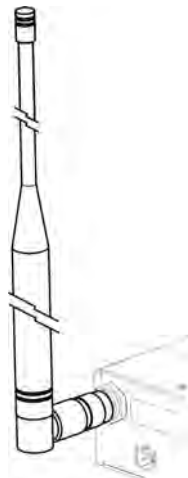
The frequency range of the antennas should match the receiver and transmitter of the base station. Match the color code on the antenna with the color code on the base station.

Attach the transmit 1/2-wave antenna to the antenna input receptacle labeled Transmit on the right side of the rear panel. The antenna should be vertically aligned.



**FIGURE 10.**  
**Attaching Transmit 1/2-Wave Antenna**

Attach the receive 1/2-wave antenna input receptacle labeled Receive on the left side of the rear panel. The antenna should be vertically aligned.



**FIGURE 11.**  
**Attaching Receive 1/2-Wave Antenna**

## Antenna Polarization

The RTS Wireless Intercom System is Vertically Polarized. This means both the transmitting and receiving antennas should operate in the vertical position.



ANTENNAS SHOULD BE VERTICAL

**FIGURE 12.**  
**Vertically Polarized Antennas**

## Distance between Antennas

The distance between the base station's receive and transmit antennas is not adjustable when the antennas are connected directly on the back of the unit.

The antennas can be removed for better signal path. An RTS coax assembly with remote antennas may be required. See "Accessories and Replacement Parts" on page 83 for ordering information.

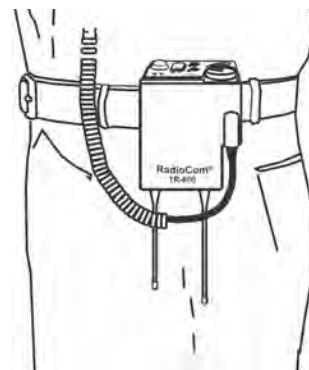
**NOTE:** If your base station is to be located in a shielded rack mount enclosure or other poor RF location, you must remove the 1/2-wave antennas with coax assemblies. See "Accessories and Replacement Parts" on page 83 for remote mounting hardware.

## Antenna Placement

Proper antenna placement probably has the most effect on your RTS Wireless Intercom System's overall performance. The following suggestions will result in optimum performance.

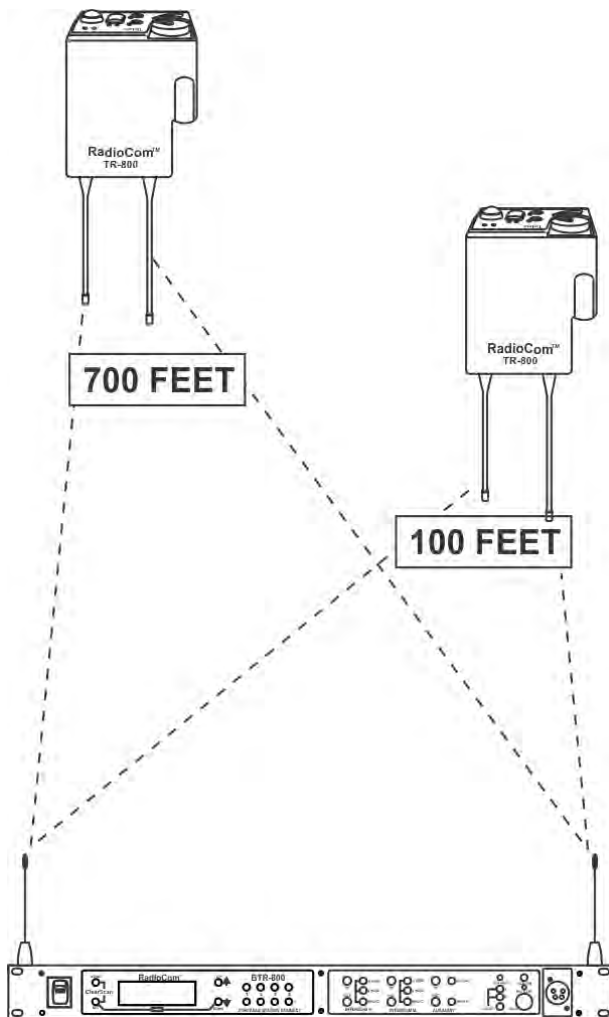
Proper placement of the beltpack can be critical. The antennas should be in the open. Bending the antennas up and placing the beltpack in a pocket, etc., will reduce system distance.

It is suggested that the unit be worn on the belt with both antenna's vertical for best operating range and performance.

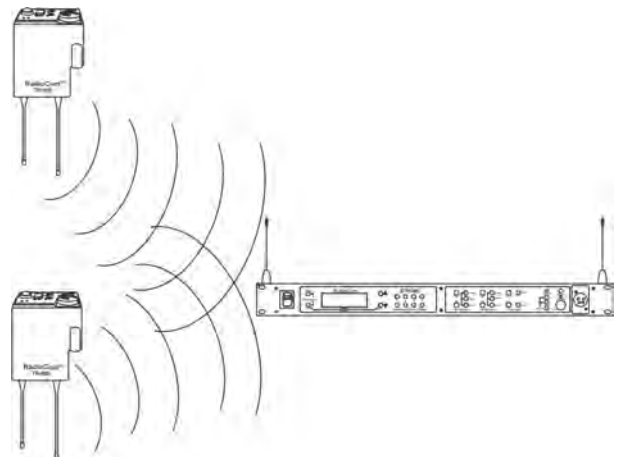


**FIGURE 13.**  
**Proper Dressing of the Antennas**

Keep the distance between the base station and the belt packs as short as possible. The greater the distance, the weaker the signal. Make sure the signal paths between the base station and belt packs are unobstructed. You should be able to visibly locate the base station antennas at all times for best performance.

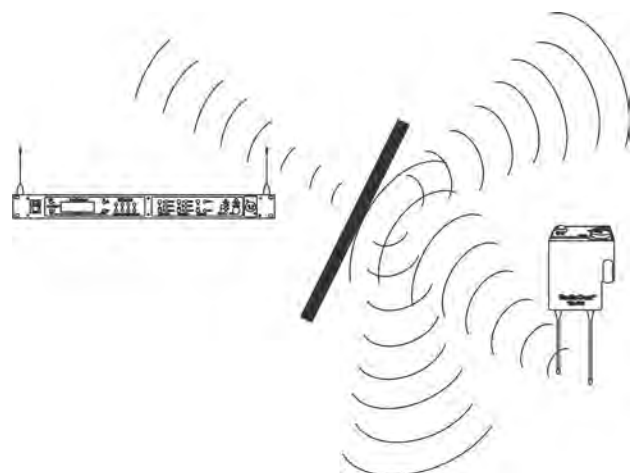


**FIGURE 14. Distance Between base station and belt pack**



**FIGURE 15. Keeping Site Clear to Antenna**

Attempting to operate the wireless intercom system through or around walls, ceilings, metal objects, etc will reduce system range and performance.



**FIGURE 16. Operating System Near Obstructions**

**IMPORTANT:**

Do not mount the base station 1/2-wave antennas on, or next to metal, such as beams, walls with metal studs, equipment racks, etc. This also applies to the antennas when assembled directly to the Base Station. This will detune the antennas which can result in noise or loss of RF signal at the Base Station, see Figure 17.

2. Placing the BTR on top of a shelf or equipment rack unobstructed without remoting the antennas is OK.

1. Placing BTRs in a shelf or equipment rack and using remote antennas is OK.

3. Placing BTRs in a shelf or equipment rack with the antennas mounted on the back of the BTR or the side of the rack is **BAD**.

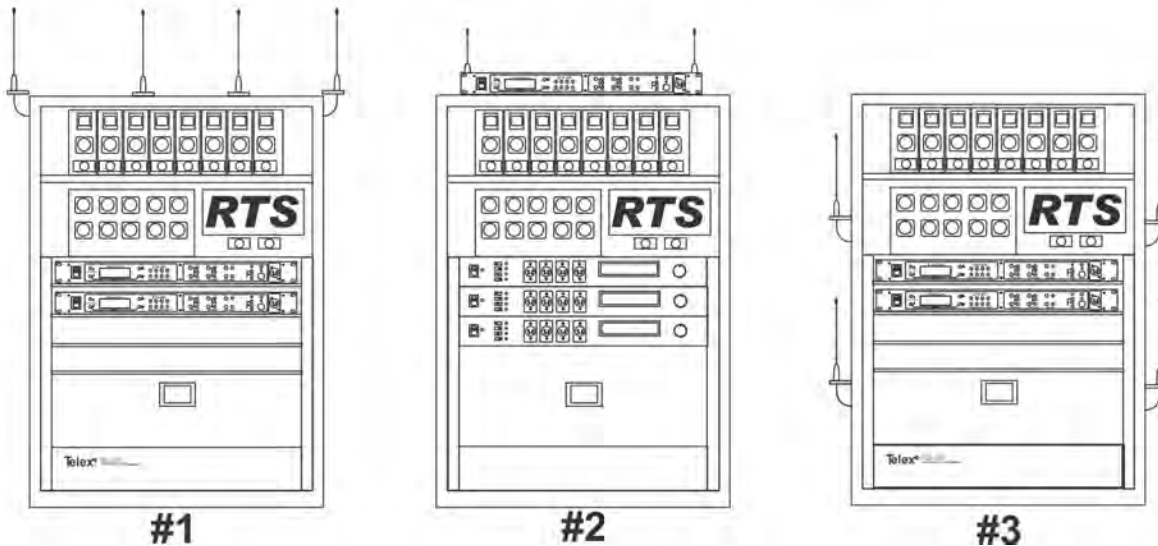


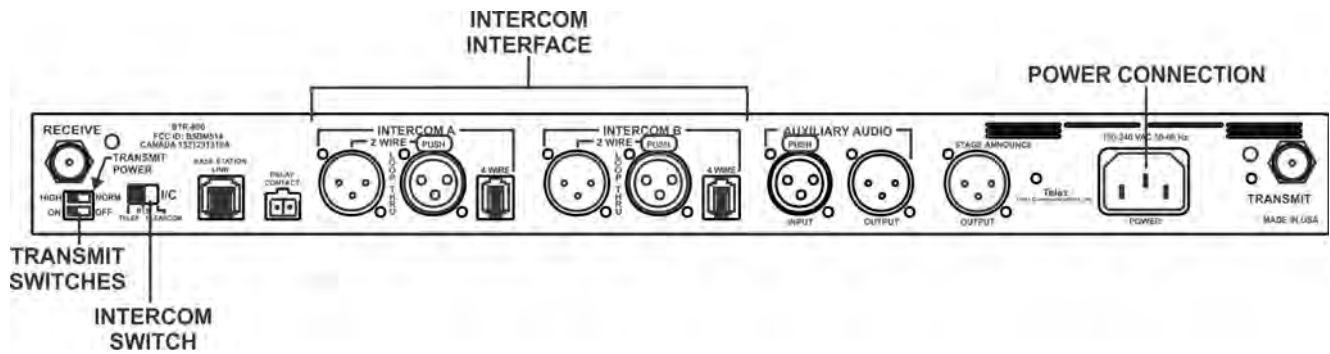
FIGURE 17. Antenna Placement

### Improving Reception and Increasing Range

Keeping the distance from the base station and beltpack as short, and unobstructed as possible will produce the most reliable performance.

The base station is supplied with two antennas. This should provide satisfactory system performance in most applications. System range can be enhanced by remoting the 1/2-wave antennas. The 1/2-wave antennas are ground plane independent, so a ground plane is not required for good performance.

## Base Station Set-up



**FIGURE 18.**  
Base Station – Rear Panel

### Location

Locate the base station with the front and rear of the unit accessible so that switches may be set and connections made. Place the transmit and receive antenna's on the base station. Make sure the color band match the color dot near each antenna. See "Antenna Placement" on page 22 for more information on choosing a proper operating location.

### Power Connection

Plug the supplied power cord into the unit. The base station has an IEC power receptacle that accepts 100-240 VAC, 50-60 Hz. The specific receptacle type is an IEC 60320/C14. The cord it accepts is an IEC 60320/C13. These cords are common and available through many retail hardware/electronic stores if the cord is lost.

### Transmit Switches

There are two switches located on the lower left side of the rear panel. The upper switch sets the transmit power levels to high or normal. The lower switch turns the transmitters on or off.

#### *Transmit Power*

Set the power level to normal if using the beltpacks at close to medium distances (<200 feet, 161m, line-of-sight) from the base station. Set the power level to high if using the beltpacks at a distance (>200 feet, 161m, line-of-sight) from the base station.

#### *On/Off*

Set the transmitter switch to on for normal use. In the off position both base station transmitters are disabled. Setting the switch to off will disable all the beltpacks from hearing anyone else or even their own sidetone.

### Internal Transmit Switches

Internal to the BTR-800 are two transmit switches which enable a user to turn on or off the two transmitters individually. See Figure 19 for the location. The top cover of the base station must be removed for access. The switch closest to the front panel controls transmitter 1 (audio channel A). The switch behind that is transmitter 2 (audio channel B). The default switch position is to the left if you are facing the front of the base station. This is the ON position of the transmitters.

In the normal use of the BTR-800, there is no need to access these switches. They are used to test the transmitters individually at the factory.

### Intercom Switch

The RTS wireless system can be interfaced to RTS, TW, Audiocom (TELEX), Clear-Com, RTS matrix and other intercom (I/C) systems. Set the Intercom switch on the rear of the unit to the appropriate system and connect the system to the base station. The two intercom channels on the rear of the base station have loop-thru male and female XLR connections for two-wire systems and RJ-11 type jacks for four-wire systems.

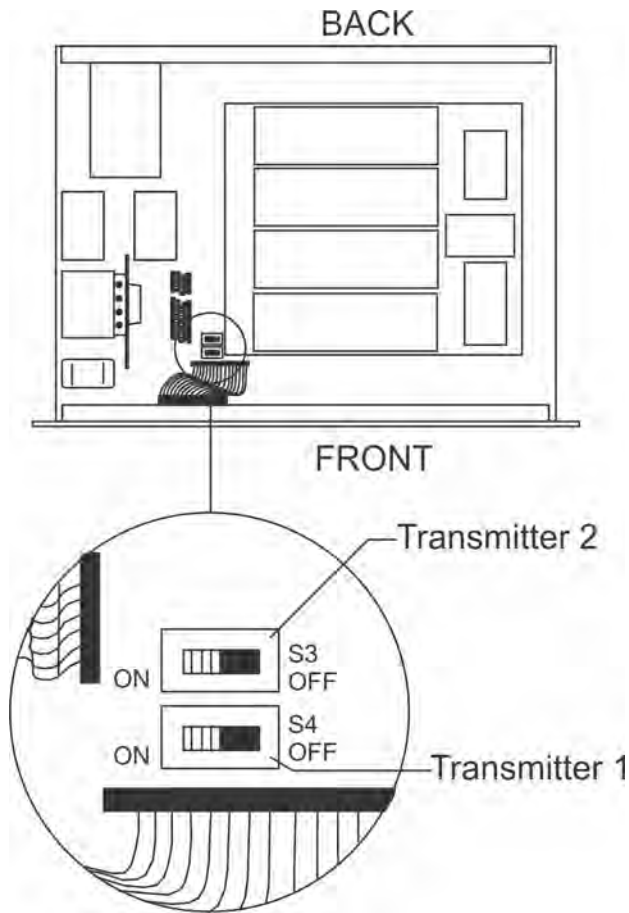
This switch only affects the two-wire intercom systems. The function of the I/C XLRs change depending on the intercom selected. Please see "Intercom Systems Specifications" on page 81 for pinout information of the different two-wire intercom systems.

### Intercom Interface

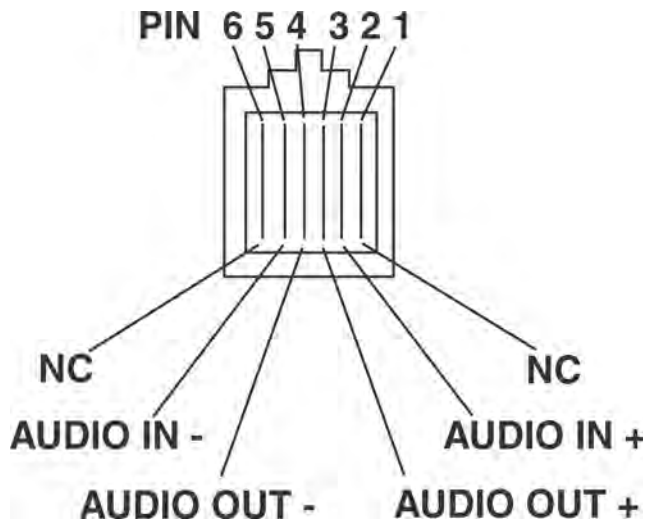
Audiocom (TELEX) and ClearCom intercom systems require one cable for intercom A and one cable for intercom B in order to interface two channels of intercom to the base station. This interfacing is done through the I/C A and B 3-pin XLR connectors on the rear of the unit.

RTS TW intercoms only need to connect one 3-pin cable to one of the four intercom XLR connectors since two channels of audio are carried on one cable. The intercom switch parallels the four XLR connectors when in RTS mode. RTS channel 1 is placed on intercom A and RTS channel 2 is placed on intercom B as long as the RTS TW input to the base station is wired as in "Intercom Systems Specifications" on page 81.

Four-wire intercom systems require one cable for intercom A and one cable for intercom B in order to interface two channels of four-wire intercom to the base station. This interfacing is done through the I/C A and B RJ-11 type jacks on the rear of the unit. See Figure 20 for the pinout of the RJ-11 jacks.

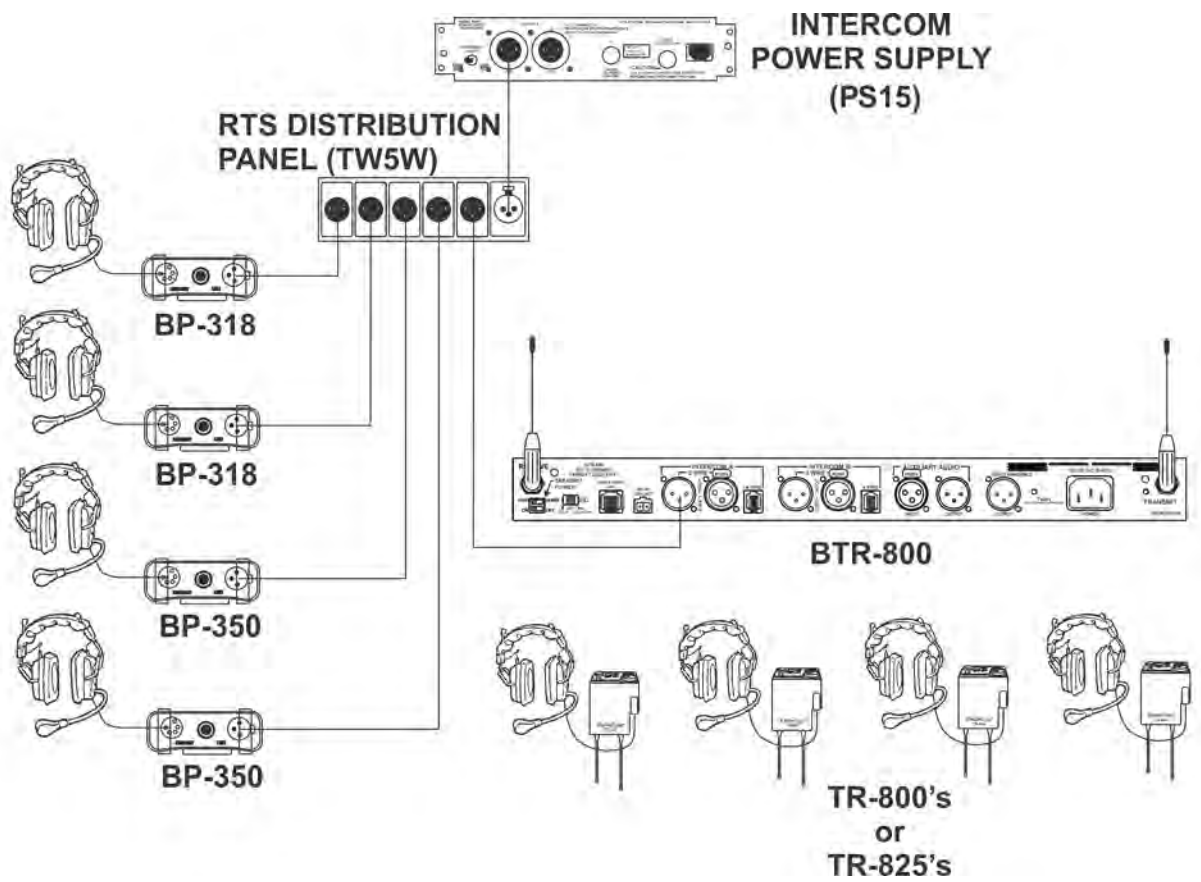


**FIGURE 19.**  
Internal Transmit Switches



**FIGURE 20.**  
RJ-11 Type/Four-wire Pinout





**FIGURE 21.**  
**Example Interface to an RTS TW System**

### Dual Listen Functionality

The base station's main audio board has the option of placing additional parts to enable dual listen. Dual listen allows the mixing of the intercom channels. The mixing will occur locally, within the base station, and is only heard on that base station's beltpacks. The user will have the ability to enable/disable the mix of I/C A into I/C B or vice versa. If you have TR-825 beltpacks, there is no need to install this base option. The level

of the mix can be controlled at the TR-825 via the two volume controls.

They will also have the ability to control the level of the mix (-4dB to -24dB down from the main channel). Removing two surface mount resistors and installing two SPDT switches and two potentiometer enables dual listen. The parts to be installed are shown in Table 1. The two resistors on the board to be removed are in Table 2.

Board Designator	Description and Function	Value	Manufacturers, Part No.
VR5, VR6	Potentiometers VR5 = Controls I/C A into I/C B Mix VR6 = Controls I/C B into I/C A Mix	20kΩ –25kΩ	Bourns, 3309P-1-203 CTS, U262R253B Piher PT10LV10-203A2020
S6, S7	Switches S6 = Enable/Disable I/C A into I/C B Mix S7 = Enable/Disable I/C B into I/C A Mix	SPDT	E-Switch, 500ASSP1M2RE E-Switch, EG1218 AlcoswitchTSS11DGPC

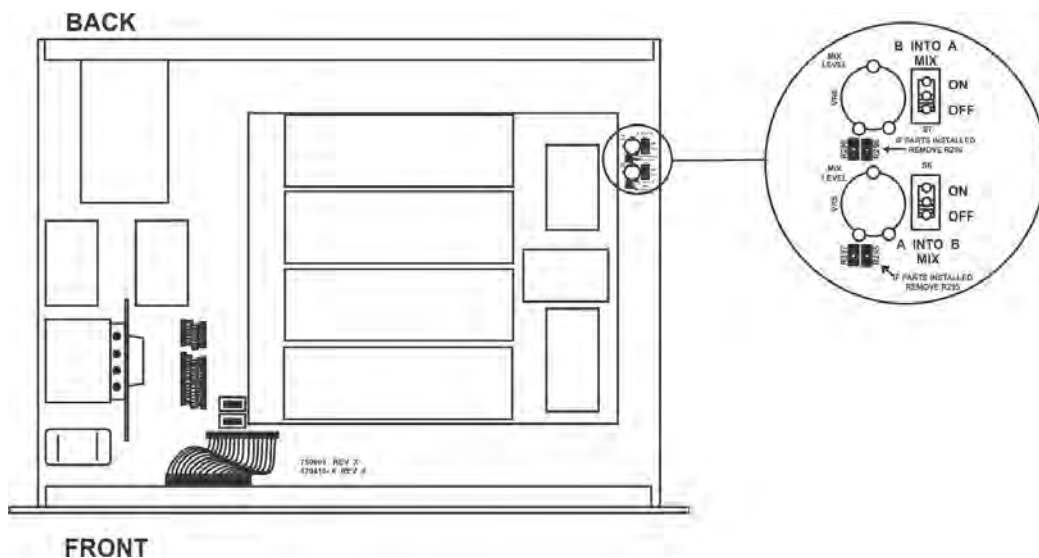
**TABLE 1.**  
**Parts to be installed by User to Enable Dual Listen**

Board Designator	Description and Function	Value
R295	Resistor, Default if mix components not installed	10k
R296	Resistor, Default if mix components not installed	10k

**TABLE 2.**  
**Parts to be Removed by User to Enable Dual Listen**

The listed manufactures and part numbers in Table 1 are those that the audio board was laid out for and thus the hole pattern used. Several of these parts may be found at Digi-Key and other distributors. Trim the leads on the parts so they cannot hit the metal case. Locations to place these components are provided on audio board part number 750608 and ASY000108000.

The audio board part number is located on the lower left hand side of the board if facing the front of the unit. The location where the components can be installed are on the upper right hand side of the board. See Figure 22 for the locations. Board part number 750541 does not have locations to place components, however, modification documents may be obtained from Bosch Security Systems, Inc. for those who wish to modify older audio boards for dual listen.



**FIGURE 22.**  
**Audio Board Part Number and Dual Listen Component Locations**

## Auxiliary Input/Output

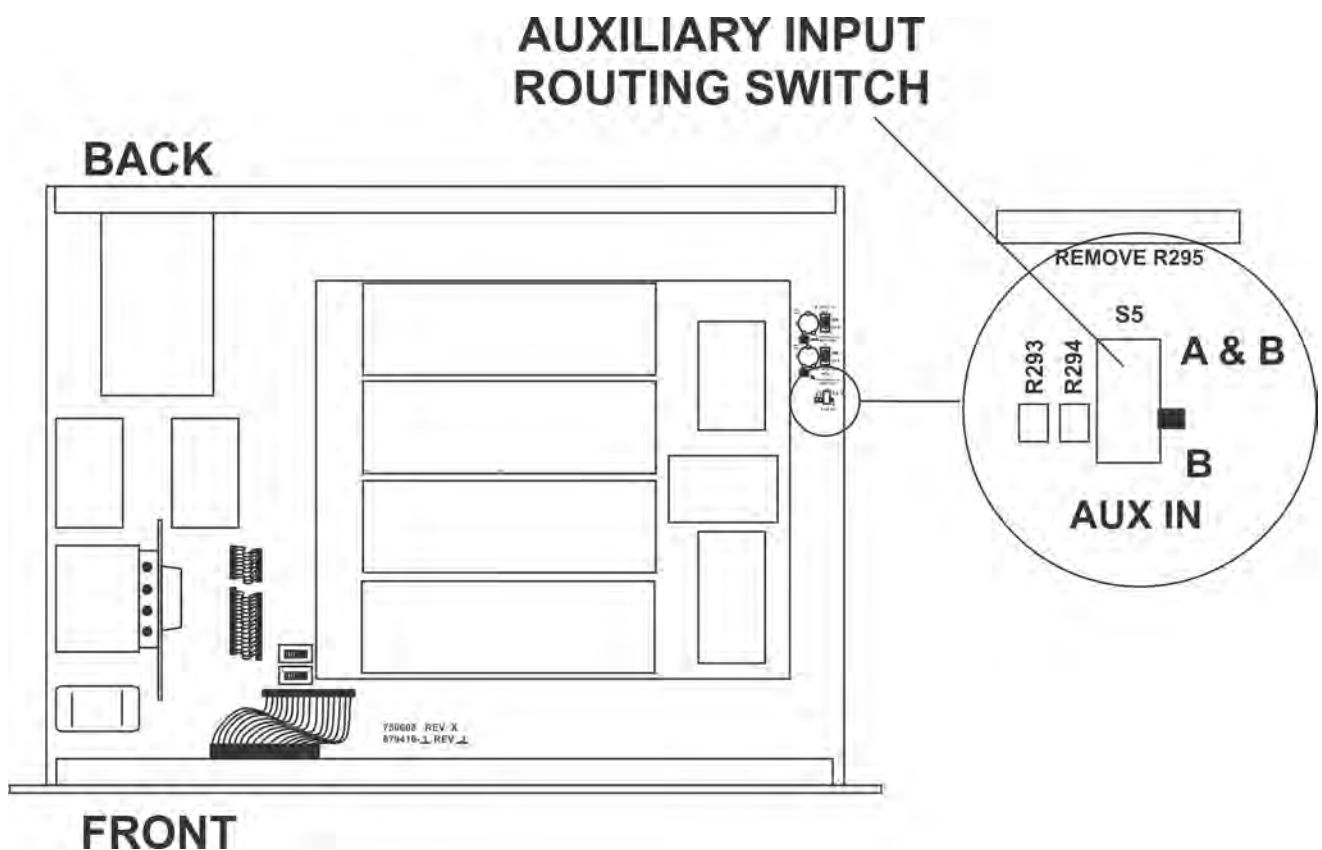
The input and output 3-pin XLR auxiliary connections are for supplying additional balanced audio into and receiving balanced audio from the base station. **The output auxiliary connection only interfaces to intercom B.** However, there is an internal switch to control the routing of the input auxiliary audio. See “Internal Auxiliary Input Routing Switch” on page 29.

**The input and output auxiliary audio is global.** This means the input auxiliary audio is placed on the base local headset, beltpack(s), headsets, and **any wired intercom system interfaced to the base station.** The intercom channel(s) the input auxiliary audio is placed on depends on the position of the input routing switch. The output auxiliary audio is also taken from the intercom B base local headset, beltpack(s), headsets,

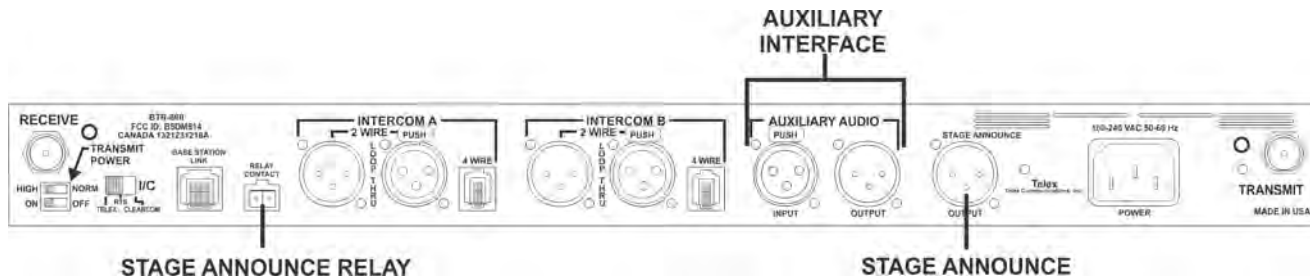
and **any wired intercom connected to the base station.** A modification document is available from Bosch Security System, Inc. for those who wish to modify the base station so that auxiliary input audio is heard only locally; base local headset and beltpack(s) headsets.

## Internal Auxiliary Input Routing Switch

This switch controls the routing of the input auxiliary audio. This switch has two positions. The B position places auxiliary input audio onto intercom B only (default from factory). The A & B position places auxiliary input audio onto intercom A and B. See Figure 23 for the locations of this internal auxiliary input routing switch.



**FIGURE 23.**  
Auxiliary Input Routing Switch

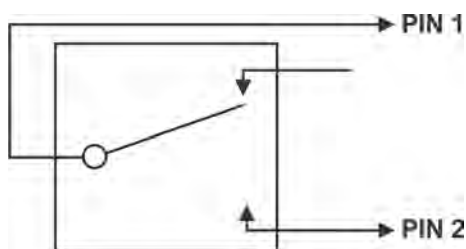


**FIGURE 24.**  
Base Station – Rear Panel

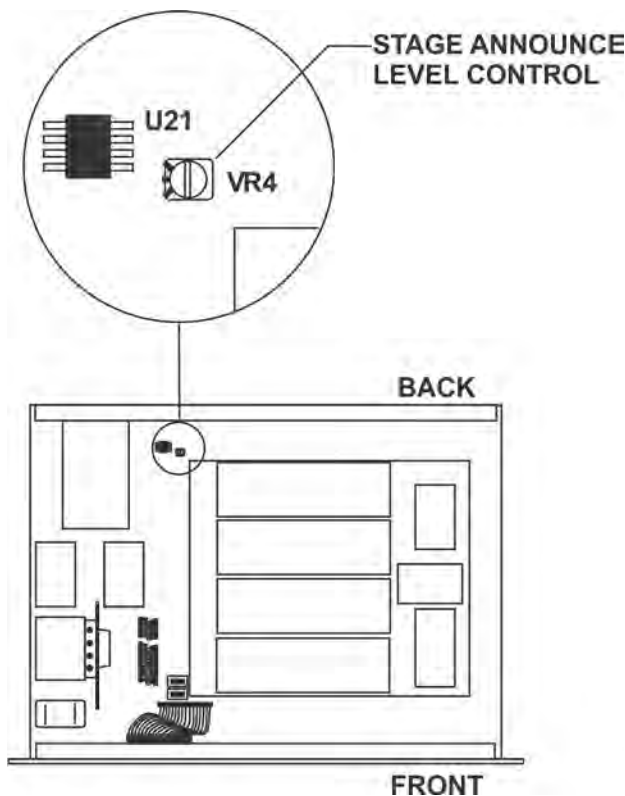
**Stage Announce / Relay Contacts**

The stage announce output connector is where the audio exits the base when any of the beltpacks press the [SA] button. The output is balanced audio though a male 3-pin XLR. The state announce output level is set at the factory for 2 Vrms typical output at rated deviation into 600 Ohms. This should be adequate for most applications. There is an internal level adjustment for this output too. See Figure 27 for the location of the small level trimmer. The top cover of the base station must be removed for access.

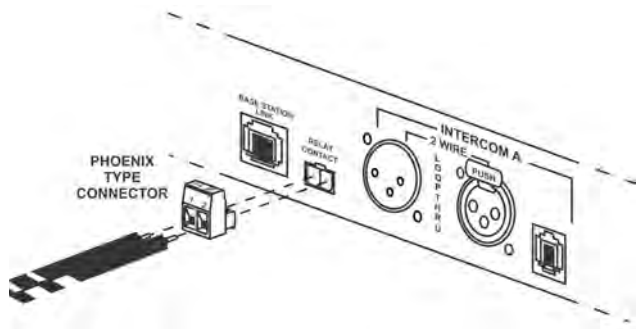
A relay contact closure is also activated when a beltpack user presses the [SA] button. The contacts are normal open (N.O.). Rating: 1 Amp at 24 volts AC/DC maximum. A Phoenix type connector (supplied) plugs into the relay contact port on the rear of the base station. This connector provides a screw-type closure for an easy connection to wires.



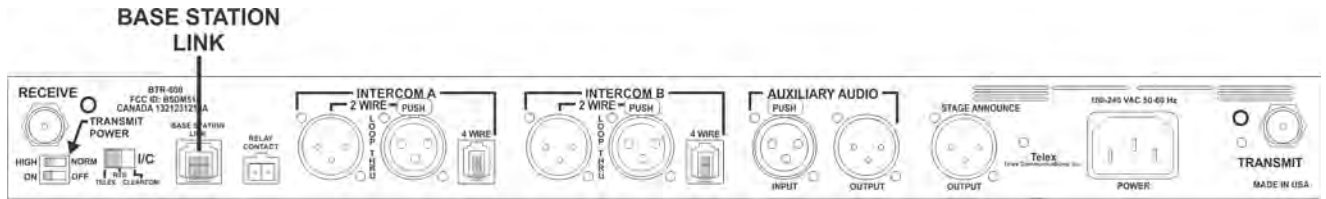
**FIGURE 25.**  
Relay Output Schematic



**FIGURE 27.**  
Internal Stage Announce Level Control



**FIGURE 26.** Relay Contact Jack Adapter (Screw Terminal Adapter)



**FIGURE 28.**  
**Base Station – Rear Panel**

**Base Station Link**

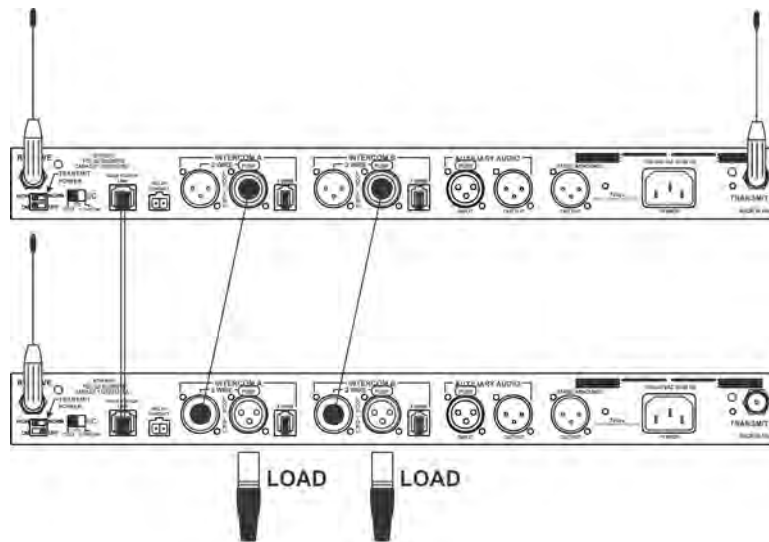
This RJ-45 type jack allows the connection of wireless talk around (WTA) to two base station of the same frequency bands. This allows WTA on I/C channel A and WTA on I/C channel B to be carried through to the other base station attached together via this jack.

WTA channel A and channel B is contained within a base station unless the transmit power is off. If it is off, the WTA audio is routed through the base station link cable to the other base that has its transmitter on.

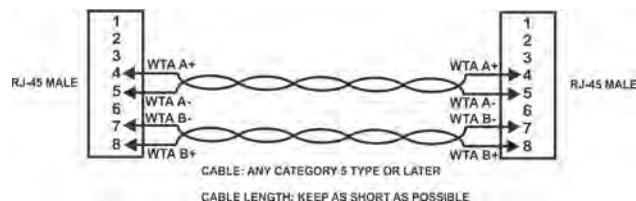
A cable to accomplish this task is NOT supplied, but can easily be made with common category 5 (CAT-5) or later wiring.

In fact, the most common 10BaseT Ethernet patch cables, 568-B wired cables, can be used to connect bases together. The required cable is shown below.

The regular two-wire intercom channels are passed from base to base via the wired intercom cables and do not require the base station link cable.



**FIGURE 29.**  
**Two Stand Alone Base Stations Connected Together**



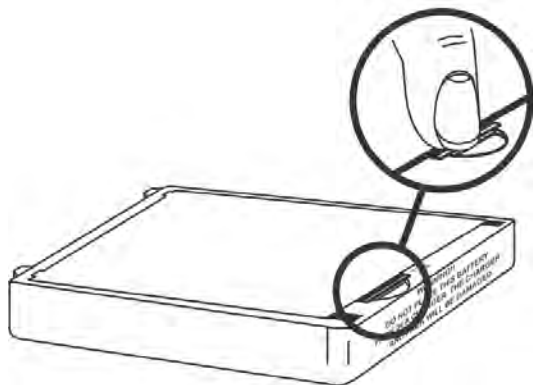
**FIGURE 30.**  
**Base Station Link Cable**

## Beltpack Setup

### Battery Installation

Ensure that the On/Off volume control knob is turned off. Press down and hold down the battery release latch, slide the battery pack about 1/8-inch back, toward the latch, until it stops. Then lift the battery pack out. Replace the batteries as follows:

1. Open the battery pack by inserting finger nail and lifting.



2. Pull battery strap to remove low or dead batteries.

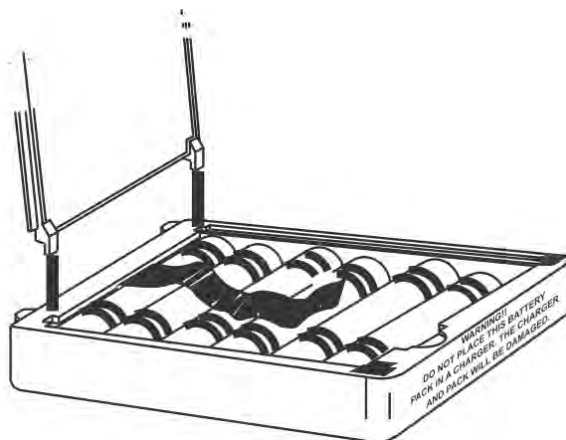


3. Load new batteries following the polarity, as shown in the battery case.



4. Start loading at the end of the case where the strap is attached to the case.
5. Be sure the strap goes under the batteries.

6. Tuck end of strap under door when placing the battery cover back on the case.



**FIGURE 31.**  
Battery Installation

---

**WARNING:** Do not place an alkaline TR battery pack in any battery charger. Severe charger and battery pack damage may result.

---

7. For the TR-825, ensure that both On/Off volume control knobs are turned off prior to inserting the battery pack onto the TR-825 to prevent the possibility of a voltage spike that could the unit to become inoperable.

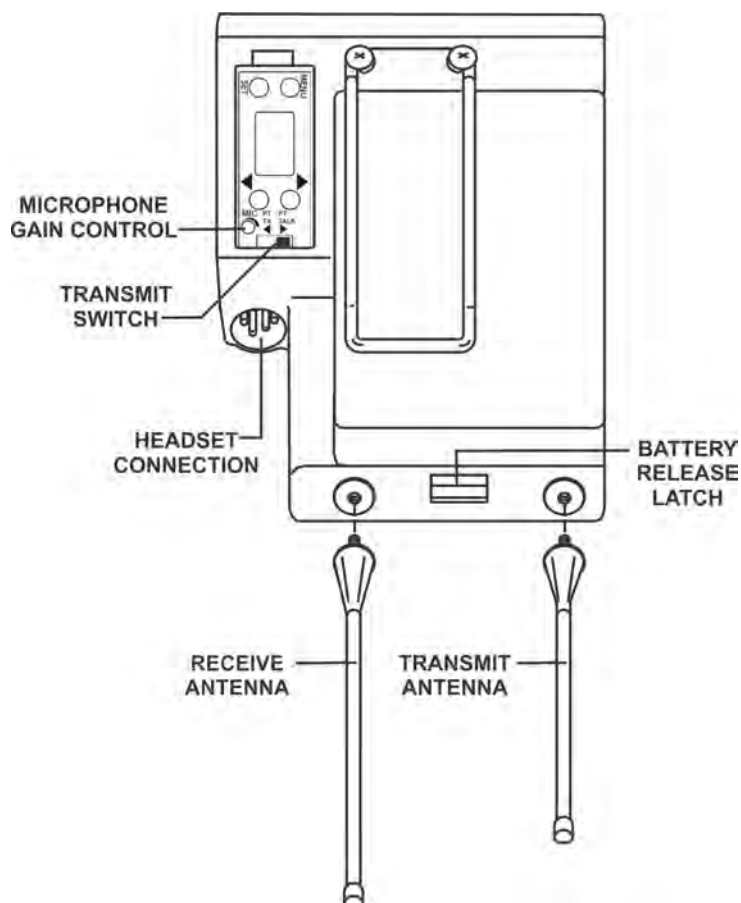


FIGURE 32.

FIGURE 33. TR-800 and TR-825 Rear Panel

### Antenna Connection

The beltpack comes with two detachable, screw-type, 1/4-wave antennas. To attach the two antennas, screw into the receptacles at the bottom of the beltpack. The color dot on the screw end of the antenna must match the color dot on antenna receptacle. The receive antenna screws into the left receptacle if the beltpack is laying flat with the battery compartment face up and the antenna receptacles facing you. The other antenna is the transmit antenna. New antennas can be ordered if desired, see “Accessories and Replacement Parts” on page 83.

### Transmit Mode

The rear panel located transmit switch has the following two modes:

**Push-to-Talk (PT TALK)** – Recommended position - The transmitter is always on. No audio is sent unless the talk switch, WTA or SA button is pressed.

**Push-to-Transmit (PT TX)** –The transmitter and audio path are off except when the talk switch, WTA or SA button is pressed.

### Headset Connection

Insert the headset plug into the XLR connector. See the headset pinout in the TR-800/TR-825 beltpack controls and connections section if this is not a Telex headset. A dynamic or electret headset microphone is automatically detected by the beltpack and a bias voltage supplied, if needed.





## *Pre-Walk-Thru Checklist*

---

Following the instructions fully to this point you have successfully completed the following checklist:



Located the base station properly.



Connected power to base station



Connected the 1/2-wave antennas to the base station. Checked frequency range of the antennas with the frequency of the base station by correctly matching color codes.



Connected 1/4-wave antenna to the beltack. Checked frequency range of the antennas with the frequency of the beltack by correctly matching color codes.



Base station transmit power switches in the correct positions.



Transmit mode switch on beltack set correctly.



Set wired intercom type correctly.



Connected headsets to base stations (if needed) and all beltacks.



Connected the base station to any auxiliary audio, intercom, external P.A. system, or relay contact detect circuit, if needed.



Installed batteries in the beltack.



If you missed any of the above instructions, go back and complete that instruction before going on.



**Frequency Plan Overview**

The BTR/TR-8XX has 36 factory defined frequency groups and 12 user-programmable frequency groups. A **Group** defines the two-base station transmit frequencies and thus the two receive frequencies on all the beltacks. A **Channel** defines a base station receive frequency and thus a beltack transmit frequency. A base station receive channel that does not have a frequency set for it will have a dash to the right of it on the Group/Channel select screen. Details on setting frequencies may be found in the BTR 800 Menu Structure on page 40 and TR-8XX Menu Structure on page 49.

**Factory-Defined Groups**

The 36 factory-defined groups were carefully chosen to avoid certain intermod products and various other possible sources of interference. The Groups are set and cannot be changed. There is a limited number of channels which can be chosen from within these groups.

The first 24 factory-defined groups (01A – 12B) are pair groups that can be used for single (up to four beltacks) and dual (up to eight beltacks) BTR-800 systems. They are arranged 01A, 01B, 02A, 02B...011B, 12A, 12B. A pair group, like 1A and 1B, have different base station transmit frequencies, however, they both have the same eight base station receive channels from which to choose. Each channel represents a unique frequency. For example, one BTR-800 could be set on Group 02A and channels 01, 02, 03, and 04. The other BTR-800 could set on Group 02B channels 05, 06, 07, and 08. As long as the channels are different, everything should be fine.

The next 12 groups (13–24) are single groups that primarily are used for single (up to four beltacks) BTR-800 systems. The number of channels from which to choose from in these groups will vary from group to group.

Three band base stations and beltacks used in the US have a reduced channel map offering due to regulatory changes that reduced the size of the three band. Please see Section 16 for more information.

**User-Programmable Groups**

The 12 user-programmable group are initially empty. The transmit and receive frequencies are fully editable within these groups. In fact, factory-defined groups may be copied to user-programmable groups and then edited, if desired. See the BTR-800 Menu Structure on page 40 and TR-8XX Menu Structure on page 49 for details on how to copy and edit frequencies.

**System Quick Start**

Follow the list below to quickly get a base station and beltack(s) operating. When completed the user should have a base station and 1 to 4 beltacks up and running with full operational ability. The base station will be on Group 01A with its four receivers on channels 01, 02, 03, and 04. Each beltack will be on Group 01A with a unique transmit channel number matching one of the base station receive channels.

1. Plug-in the base station via the supplied power cord and connect the antennas. The color dots on the base should match the color rings on the antennas.
2. Base station rear panel switches: Transmit power set to High and on.
3. Ensure base station rear panel IC switch matches attached wired intercom system. If used stand alone or connected to a 4-wire system then IC switch position is not applicable.
4. Press [MENU] as powering-up the base station. This will place it on group 01A and set the receives on channels: 01, 02, 03, and 04.
5. Place the front panel IC A and IC B IN and OUT level controls in the 12:00 o'clock position. Check that front panel IC A and B is in 2-wired for AudioCom (Telex), RTS-TW and ClearCom wired systems, and 4-wired for RTS Matrix and stand-alone operation.
6. Pace batteries in the beltacks.
7. Remove the rear switch cover on the beltacks. Set the beltack rear panel slide switch to push-to-talk (PT TALK).
8. Press [MENU] as powering-up each beltack. This will place the beltack on group 01A with the channel 01 flashing.
9. Use the [UP] and [DOWN] arrow buttons to change the channel to match a channel on the base station. Then press [SET]. If leaving on channel, just press [MENU]. Each beltack should have a unique channel number.
10. The group/channel on the beltack should now match the group and receive channel on the base station. Nothing should be flashing on the beltack screens.
11. Plug headsets into the beltacks and set the microphone gain so the BAT/OM LED will flash at the beginning of most words at normal speech levels.
12. **DONE.**

## Base Station Operation

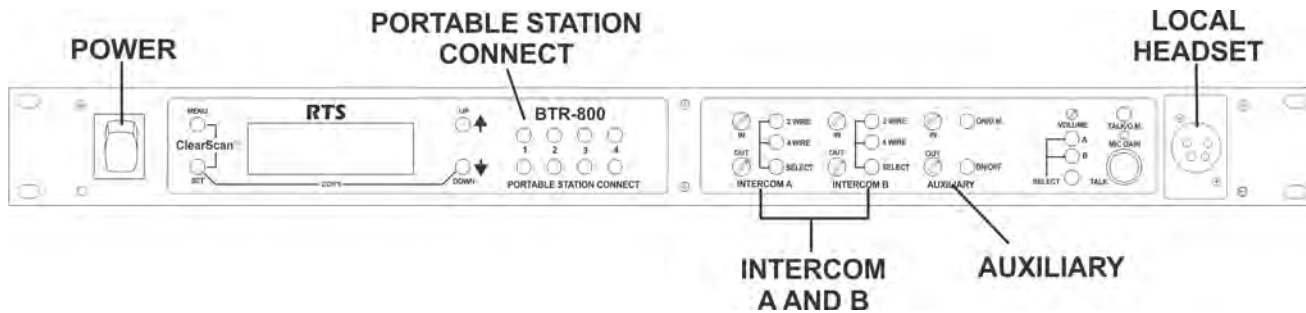


FIGURE 34. Base Station – Rear Panel

### Power

If you have followed the instructions in Section 4, Initial Equipment Setup, you should now be ready to turn the base station on.

Set the base station power switch to the on position, by pushing the top of the switch. The internal cooling fan will start immediately and the LCD display and front panel indicator lights will come on in five or six seconds.

### Local Headset

**Talk Button** – Press to enable the audio path from the local headset. The TALK/O.M. LED will turn green when audio is enabled. A quick press and release latches on the button. If the talk function is latched on, pressing the talk button again will turn it off. If the local headset is not being used, the talk button should be off. This keeps additional noise out of the system.

**Microphone Gain** – Adjusts the headset’s microphone gain. Adjust so the TALK/O.M. LED flashes from green to red on loudest speech.

**Headset Intercom Select Button** – Select the intercom system to connect to the local headset. Each press of the [SELECT] button changes the connection; Channel A, Channel B, and Both. The cycle will then repeat. The LEDs above the [SELECT] button light to indicate the current selection.

**Volume** – Adjust the volume to the headset by rotating the volume control as required for a comfortable listening volume.

### Portable Station Connect

Select the audio paths from the base station’s four receivers that you wish to enable. The corresponding LED above the select button is on when the audio path is enabled. If a belt-pack user has their portable station connect path off at the base, that user will no longer hear their sidetone and their audio will not be passed to anyone. The user will still be able to hear everyone. The selection is retained in non-volatile memory, so it will come up where last left if the unit is power cycled.

Always disable unused audio receive paths. This reduces the chances that external RF noise can get onto the audio buses via an open receiver.

### Intercom A and B

**Intercom Select Button** – Press the [SELECT] button to choose between 2-wire or 4-wire intercom systems. The green

LED will indicate the current mode of the intercom channel. If the base station is connected to a 2-wire system, such as Audiocom (Telex), RTS TW or Clear-Com, set the intercom to 2-wire. If it is connected to a 4-wire system, such as RTS Matrix, set the intercom to 4-wire. It is also possible to have intercom A connected to a 2-wire system and intercom B connected to a 4-wire system or vice versa. The selection is retained in non-volatile memory, so it will come up where last left if the unit is power cycled.

**In Level Control** – Adjusts the audio level of the wired intercom system’s input to the base station.

**Out Level Control** – Adjusts the audio level of the base station’s output to the wired intercom system.

If the base station is used stand-alone, no wired intercom system connected, it must be set in the 4-wire mode. The 2-wire mode requires a wired intercom system or appropriate load be connected to the intercom A or B XLRs. If not loaded, a large gain increase will take place in the unload intercom channel which may be high enough to produce a loud howling sound.

### Auxiliary

**Auxiliary Input Select Button** – Press the [SELECT] button to turn on or off the auxiliary input to the base station. The selection is retained in non-volatile memory, so it will come up where last left if the unit is power cycled.

**In Level Control** – Adjusts the audio level of the wired auxiliary system’s input to the base station.

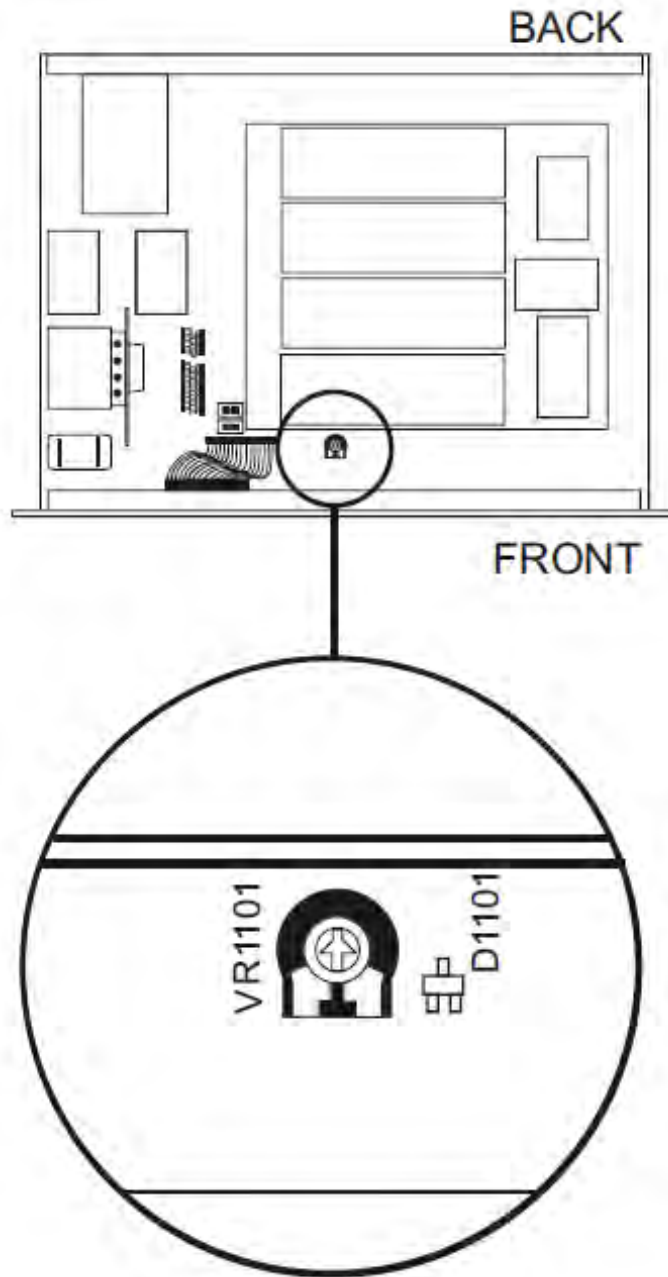
**Out Level Control** – Adjusts the audio level of the base station’s output to the auxiliary XLR plug.

The auxiliary output connects only to intercom B. It does not interface to intercom A. The auxiliary input may be switched to B intercom (default) or A and B intercom. See “Initial Equipment Setup” on page 21 for the location of this internally located input routing switch. The auxiliary output is always available at the back panel output XLR. It cannot be switched on or off like the input. Both the input and output are balanced audio ports. Auxiliary input and output audio is global. See “Initial Equipment Setup” on page 21 for more details.

**Display Contrast**

The LCD's (Liquid Crystal Display) contrast is set from the factory to a standard level. However it is possible for the user to

adjust the contrast, if desired. The contrast control is internal to the BTR-800 unit near the front panel. The cover must be removed for access to this control. See Figure 35.

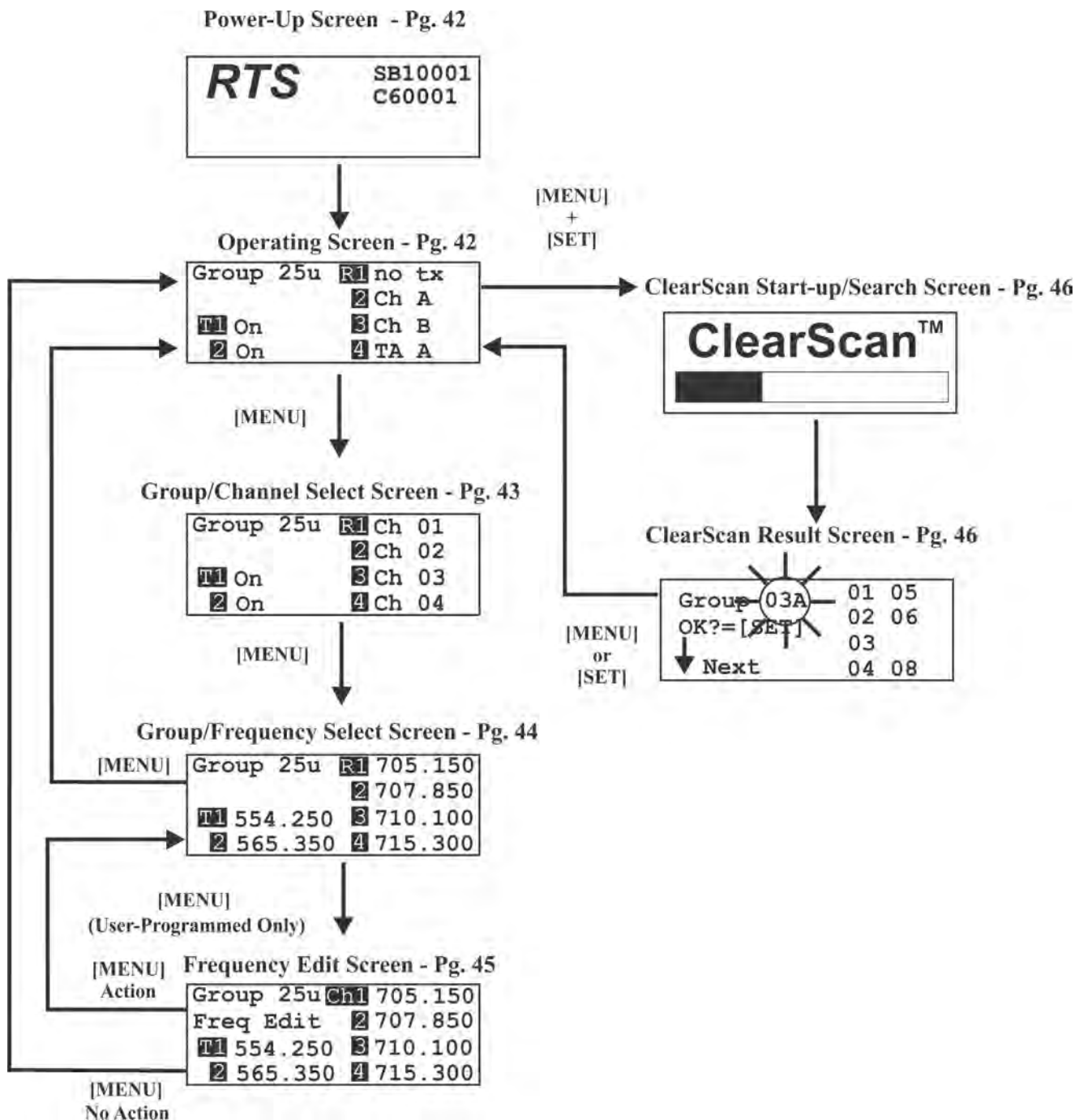


**FIGURE 35.**  
**LCD Contrast**

*BTR-800 Menu Structure*

**Main Screen Flowchart**

The following contains the base station menu structure and references the pages in which further detail of that menu may be found.



**FIGURE 36.**  
**Power-Up Screen**

**Other Special Key Sequences**

- Lockout ..... page 47
- Copy..... page 47
- 1st Use Default ..... page 47
- Factory Default ..... page 47

**NOTE:**

Pressing [MENU] within a screen after action has occurred escapes from that action and places the user at the current screen. Any editing that had been done since [SET] had been pressed is aborted.

## Power-Up Screen

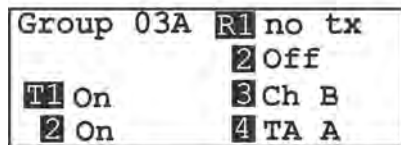
- This screen is displayed only on power up, first use default and factory default.
- The 1st upper right corner number displays the base's software revision. The single version number increments for changes in operation software.
- The 2nd upper right corner number displays the base's channel map (frequency plan) version. The single version number increments for changes in the channel map.
- Once the power-up screen is displayed, it will change to the operating screen after a few seconds.



## Operating Screen

- Screen is displayed after power-up screen.
- System will revert to this screen if no activity is detected on the LCD display buttons after three minutes.
- Screen displays current status of the system.

### Operating Screen



**Beltpack Activity Code Definitions**

no tx	No beltpack transmit carrier detected
Off	Receiver is not selected on front panel
Ch A	Beltpack audio is on Channel A
Ch B	Beltpack audio is on Channel B
Ch A&B	Beltpack audio is on Channel A and B (TR-825 only)
TA A	Beltpack Channel A Talk Around Active
TA B	Beltpack Channel B Talk Around Active
TA A&B	Beltpack Channel A and B Talk Around Active (TR-825 only)
SA	Beltpack Stage Announce Active

**NOTE:** Older versions of BTR-800 software do not support the detection of TR-825 Ch A&B and TA A&B control tones.



## Group/Channel Select

The Group/Channel select screen allows the user to change the group and select from a pre-determined number of channels on each receiver.

- Press [MENU] once to enter the Group/Channel Select Screen from the operating screen.
- Press [SET] to enter group edit. The group number will start flashing. If [SET] is pressed again without pressing the arrows, the display will go to receive 01 channel edit. NOTE: A channel that does not have a frequency set for it will have a dash to the right of it on the group/channel select screen.
- The [UP]/[DOWN] arrows will change the group number. Press [SET] again to set the group that was flashing. Now the group number will stop flashing and R1's channel number will start to flash.
- The [UP]/[DOWN] arrows will change the receive channel number. Press [SET] to set the channel that was selected. Now the second channel number will start to flash. If [SET] is pressed again without pressing the arrows, the display will go to the next channel number.
- After the last receive channel is decided upon, pressing [SET] will set that channel in the unit and start you over at the beginning of the group/channel select screen with nothing flashing.
- Pressing [MENU] will take you to the group/frequency select screen. NOTE: Pressing [MENU] after activity has occurred within the screen will return to the group/channel select screen with nothing flashing. Any change that had been done before the last [SET] was pressed will be aborted.
- Setting two channels the same is not allowed. If a channel is already set on the screen, the user no longer has that channel as an option to set into one of the other receivers.

## Group / Channel Select

Group 14	R1 Ch 01
	2 Ch 02
T1 On	3 Ch 03
2 On	4 Ch 04

[SET]

Group 14	R1 Ch 01
	2 Ch 02
T1 On	3 Ch 03
2 On	4 Ch 04

[UP] / [DOWN]  
[SET]

Group 15	R1 Ch 01
	2 Ch 02
T1 On	3 Ch 03
2 On	4 Ch 04

[UP] / [DOWN]  
[SET]

Group 15	R1 Ch 05
	2 Ch 02
T1 On	3 Ch 03
2 On	4 Ch 04

[UP] / [DOWN]  
[SET] (Last Rx Changed)

Group 15	R1 Ch 05
	2 Ch 06
T1 On	3 Ch 07
2 On	4 Ch 08

[MENU]

Group 15	R1 715.000
	2 716.700
T1 568.500	3 719.700
2 569.700	4 721.600

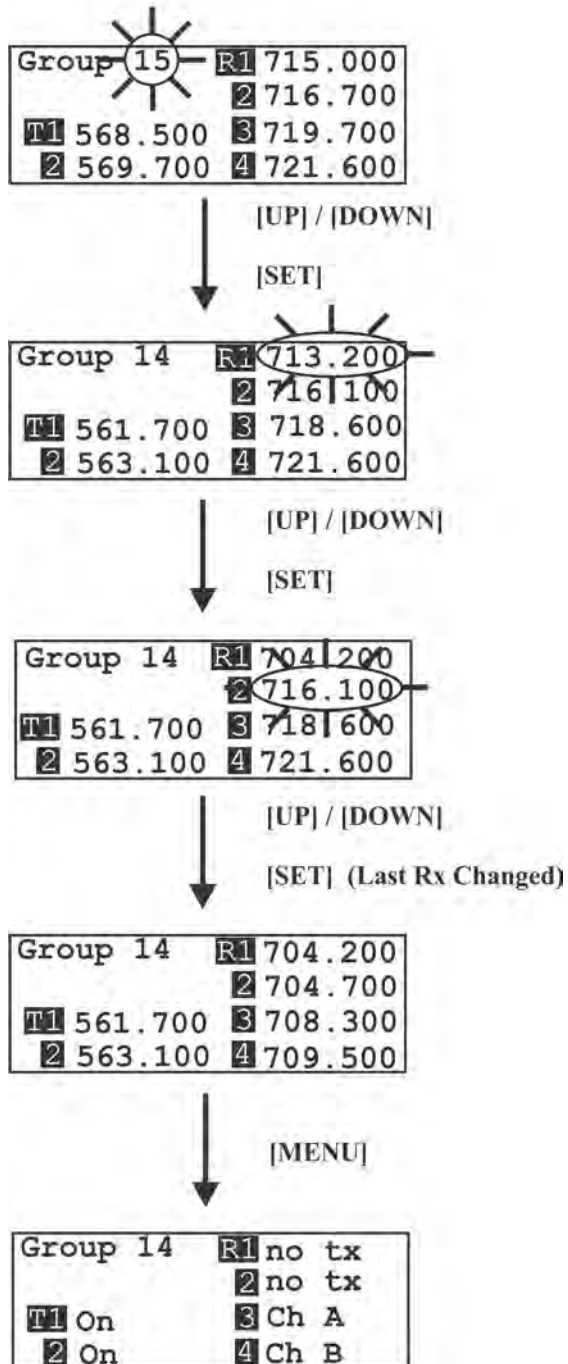
END

## Group/Frequency Select

The Group/Frequency select screen allows a user to set the group and select from a pre-determined number of frequencies on each receiver. Each frequency displayed on the right half of the screen corresponds to a channel number in the Group/Channel Screen.

- Press [MENU] twice to go to the Group/Frequency Select screen from the operating screen. Press [SET] to start the group number flashing.
- Press the [UP]/[DOWN] arrows to change the group number. The frequencies listed will reflect what is currently in that group. Pressing [SET] will select the group and start the selecting of predetermined frequencies within that group. The R1 frequency will start flashing. NOTE: The group number sets the transmit frequencies of factory defined groups and these are not editable. In user-programmed groups these are editable from the frequency edit screen.
- Pressing the [UP]/[DOWN] arrows will change the frequency of R1 to the pre-defined frequencies available. Pressing [SET] will accept the change and move you to the next channel to edit. If you had not press the arrow keys when the frequency was flashing, but instead [press [SET], you would have skipped to the next frequency to edit.
- After the last receive frequency is decided upon, pressing [SET] will save that last frequency and start you over at the beginning of the group/frequency select screen with nothing flashing.
- Pressing [MENU] will take you to the operating screen if this is a factory-defined group. If within a user programmed group, you will be taken to the frequency edit screen. NOTE: Pressing [MENU] after activity has occurred within the screen will return to the group/frequency edit screen with nothing flashing. Any change that had been done before the last [SET] was pressed will be aborted.

## Group / Frequency Select



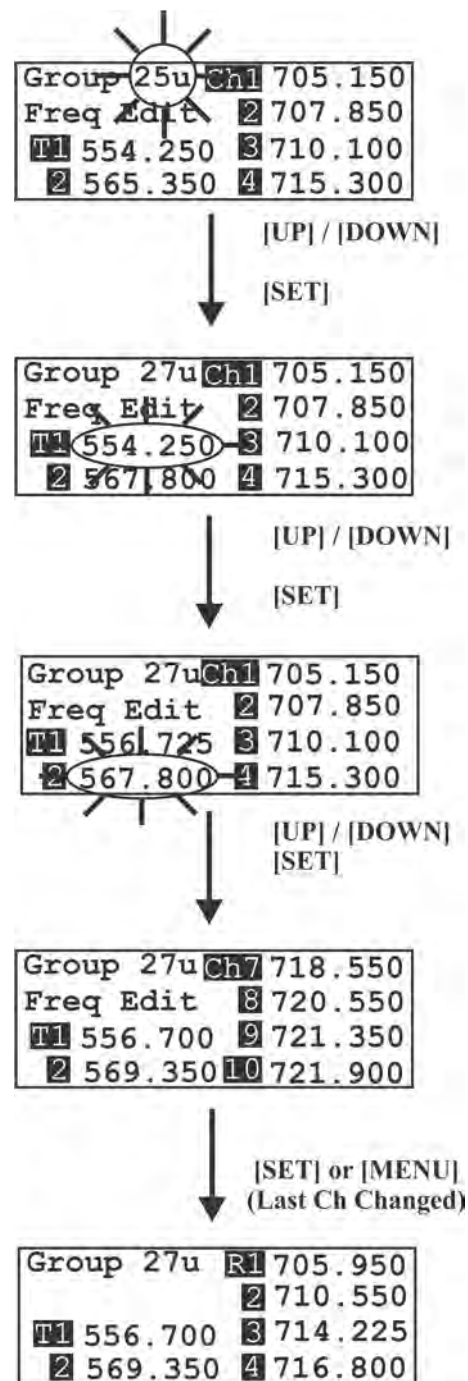
END

## Frequency Edit

### (User-Programmed Groups Only)

This menu only occurs for user-programmable groups or when copying to a user-programmable group. The Frequency Edit screen allows the user to set the group transmit frequencies and receive channel frequencies of a user-programmable group.

- Press [MENU] three times to go to the frequency select screen from the operating screen. Press [SET] to start the group number flashing. This screen allows the user to set the group and frequencies of user-programmed groups only.
- Press the [UP]/[DOWN] arrows to change the group number. The frequencies listed will reflect what is currently in that group, Dashes will be displayed in any slots that are not defined yet. Pressing [SET] will select the group and start the selecting of frequencies within that group. The T1 frequency will start flashing.
- Pressing the [UP]/[DOWN] arrows will change the frequency of T1 in 25kHz steps. Pressing [SET] will accept the change and start you editing T2. If you had not pressed the arrow keys when the frequency was flashing, but instead press [SET], you would have skipped to the next frequency to edit.
- After editing the transmit and the receive channel frequencies, pressing [SET] will save that last frequency and send you over to the beginning of the group/frequency select screen with nothing flashing. NOTE: Once the end of the displayed channel list is reached, the last displayed channel location will scroll to allow the user to edit the remaining channels.
- After action has occurred in the frequency edit screen pressing [MENU] will take you one menu back to the group/frequency select screen so that the user may see what frequencies the base receivers are now on. If no action had occurred, then pressing [MENU] will take you to the operating screen. NOTE: Besides a group change, any editing that occurs within this screen to frequencies DOES NOT take effect until the user exits the screen via setting the last channel or press [MENU].

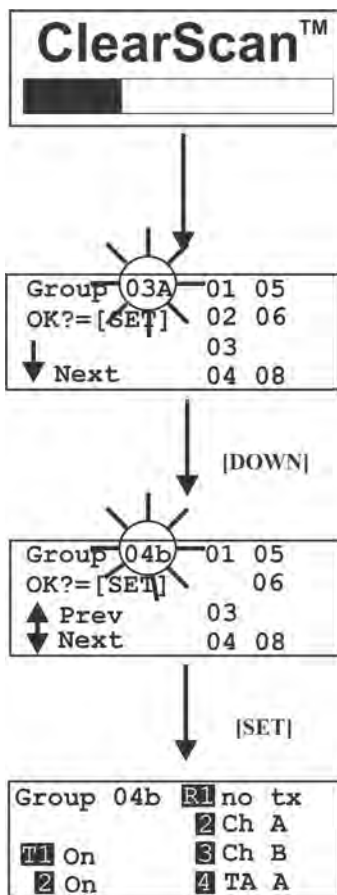


END

## ClearScan™

ClearScan™ performs a frequency scan of the factory-defined and any set-up user-programmable groups in order to find the group with the highest number of clear receive channels. After about 20-30 seconds, the group with the highest number of clear receive channels will be displayed. The next best group and so forth may be accessed with the [DOWN] and [UP] arrow buttons.

- Press and hold [MENU] + [SET] for three seconds to enter ClearScan™. The base station will now start searching all groups for the ones with the greatest number of receiver channels clear of interference.
- ClearScan™ will display the group that has the most interference free receive channels. These clear channels are displayed on the right half of the screen. Press [SET] to place the base station on this group and return to the operating screen. The first four receive channels displayed will be the ones set for the group. The [UP]/[DOWN] buttons may be used to select the next best group and so forth.



END

To achieve the best results quickly when using ClearScan™, please complete the following for setting up a single BTR-800 system:

- Turn off all wireless intercom and wireless microphone equipment.
- Turn on all wireless microphones and wireless monitor transmitters. Make sure that this equipment is distributed at least 3 to 5 feet apart from each other to minimize any frequency intermodulation effects.
- Turn on one TR-700/800/825 and perform the ClearScan function as described on page 55 and page 66 of this manual.
- When the first result is displayed on the TR, write this down along with the next 6 or 7 results. This number represents the specific BTR transmitter that should provide the best results for operation. This is referred to as the Group.
- Once you have recorded the first 6 or 7 results from the TR, turn off the TR unit.
- Turn on the BTR-700 or BTR-800 and perform the ClearScan function as described above. The results of the BTR will provide the number of Channels or TR transmitters that can operate in a given group.
- Since you have already established the best BTR Group (base station transmit frequency) to operate on, selection of the operating channels is now much easier.
- Simply match the number of TRs to operate on your system with the first and best Group number that you have recorded.
- When you have scrolled to the appropriate Group number that displays the number of belt packs to be used on the system, simply press [SET] on the BTR to place the BTR on the selected Group and Channel.
- Finally, go back to the TRs and program to the appropriate Group and Channel.

## Special Key Sequences

### Lockout

- Press [UP]+[DOWN] for three seconds to lock or unlock the base station. Pressing [MENU] will still function to view screens, but [SET] will no longer start any editing. ClearScan™, First use, Factory default are no longer accessible. The intercom channel A and B front panel 2-wire/4-wire selection is also locked into place. A padlock icon will be displayed on the second line of the display to the far left as an indication that the base station is locked out.

### Copy

- Press [SET]+[DOWN] for 3 seconds to copy any currently display group to a user-programmable group. Copy can be done from the group/channel select, group/frequency select or frequency edit screen. Once pressed, the words, “copy to” are displayed on the screen with the first empty user-programmable group flashing. If all the user-programmed groups were full, then the first programmable group is displayed. The [UP] or [DOWN] buttons may be used to select a different user-programmable group, if desired. Pressing [SET] pastes frequencies/channels to the group and takes the user to the frequency edit screen with T1 flashing.

### 1st Use Default

- Press [MENU] while turning on the base station to enter the 1st use default setup screen. This places the unit on group 01A with the four receivers set to channels 1-4 of the group. **Any user-programmed frequencies that had been entered previously are retained.** If lockout had been activated, the beltpack comes up where it was last left regardless of [MENU] being pressed on power-up.

### Factory Default

- Pressing all four buttons [MENU]+[SET]+[UP]+[DOWN] at the same time for three seconds places the unit on group 01A with the four receivers set to channels 1-4 of that group. This is just like base station 1st use default, except that **all user-programmed frequencies that had been entered previously are erased.** This function may take several seconds. If lockout had been activated, the beltpack comes up where it was last left regardless of these four keys being pressed.

## Beltpack Operation

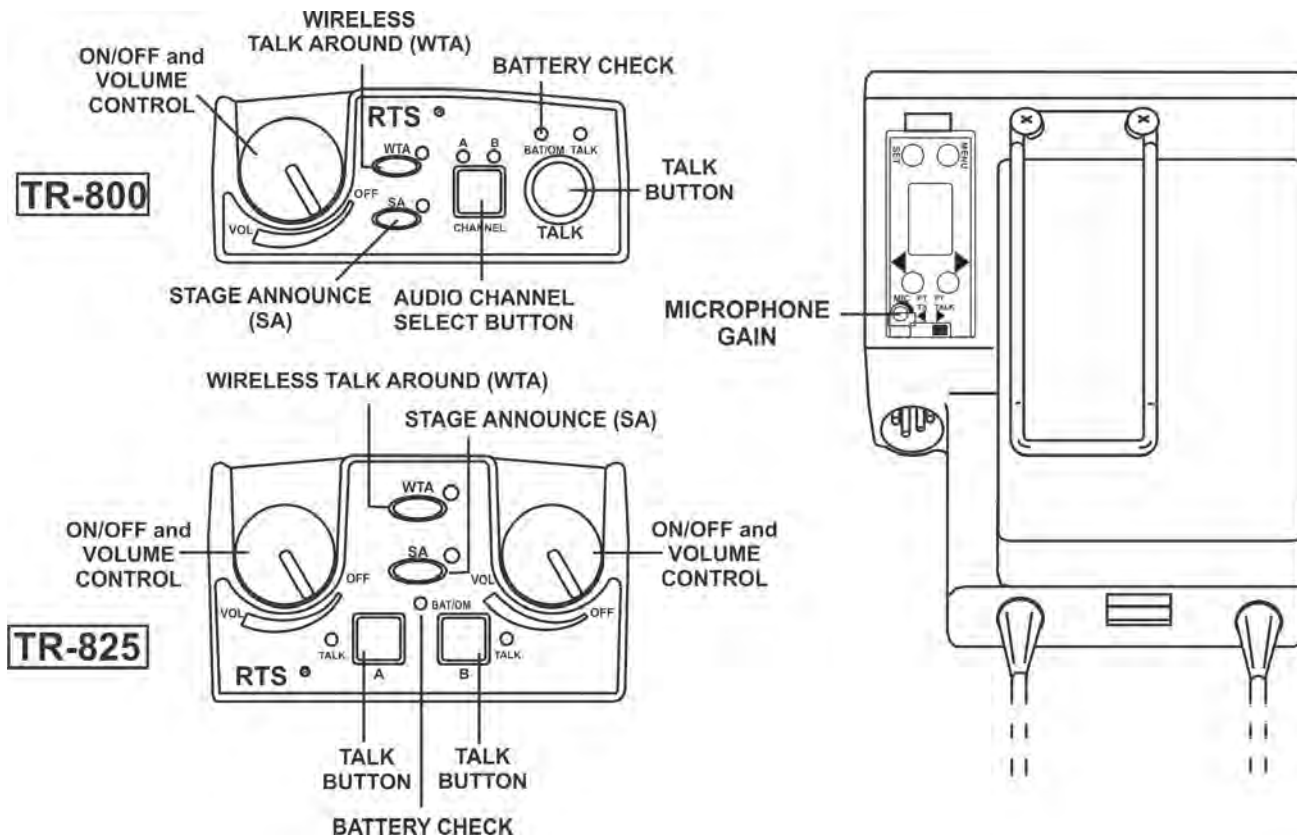


FIGURE 37.  
TR-800 and TR-825 Top and Rear Panel

### On/Off and Volume Control

Turn the beltpack power on by rotating the knob CW. Adjust the volume to the headset by rotating the volume control as required for a comfortable listening volume.

### Battery Check

When the beltpack power is turned on by rotating the knob, the BAT/OM LED will flash once if the battery is good. If the LED stays on, the battery is low. If the LED does not flash, the battery is dead.

### Talk Button

Press the talk button to enable the audio path from the headset microphone. The TALK/OM LED will turn red when audio is enabled. A quick press and release latches the talk function unless latching has been disabled. Holding the button for over 1/2 a second will cause the audio path to be enabled only for as long as the button is held. If the talk function is latched on, pressing the talk button again will turn it off. See “Talk Button Latch on/Latch off” on page 57 to learn how to enable/disable latching of the talk button.

### Microphone Gain

Adjusts the headset’s microphone gain. Adjust so the TALK/OM LED flashes red at the beginning of most words at normal speech levels. If the input is too large, the LED will be red during the complete word at normal speech level. The peak-responding audio limiter in the beltpack is very tolerant of high input audio levels. Even when the microphone gain is

maximized, and headset volume reduced to make up for the louder audio, the audio will still sound good and not clipped.

### Audio Channel Select Button

Selects the intercom system to which the headset is connected. The LED near the channel button indicates the current selection. See the “Audio Channel A or B Disable/Enable” on page 57 to learn how to enable only channel A, channel B, or both.

### Stage Announce (SA)

When pressed the audio from the beltpack is routed directly to the stage announce connector on the back of the base station. The base station’s SA relay is also closed. The beltpack sidetone is lost as an indication that stage announce is activated. The other beltpacks and wired users do not hear this beltpacks audio when SA is pressed. The button is non-latching and activates the nearby red LED when pressed. See “Stage Announce Enable/Disable” on page 56 to learn how to enable/disable the SA button.

### Wireless Talk Around (WTA)

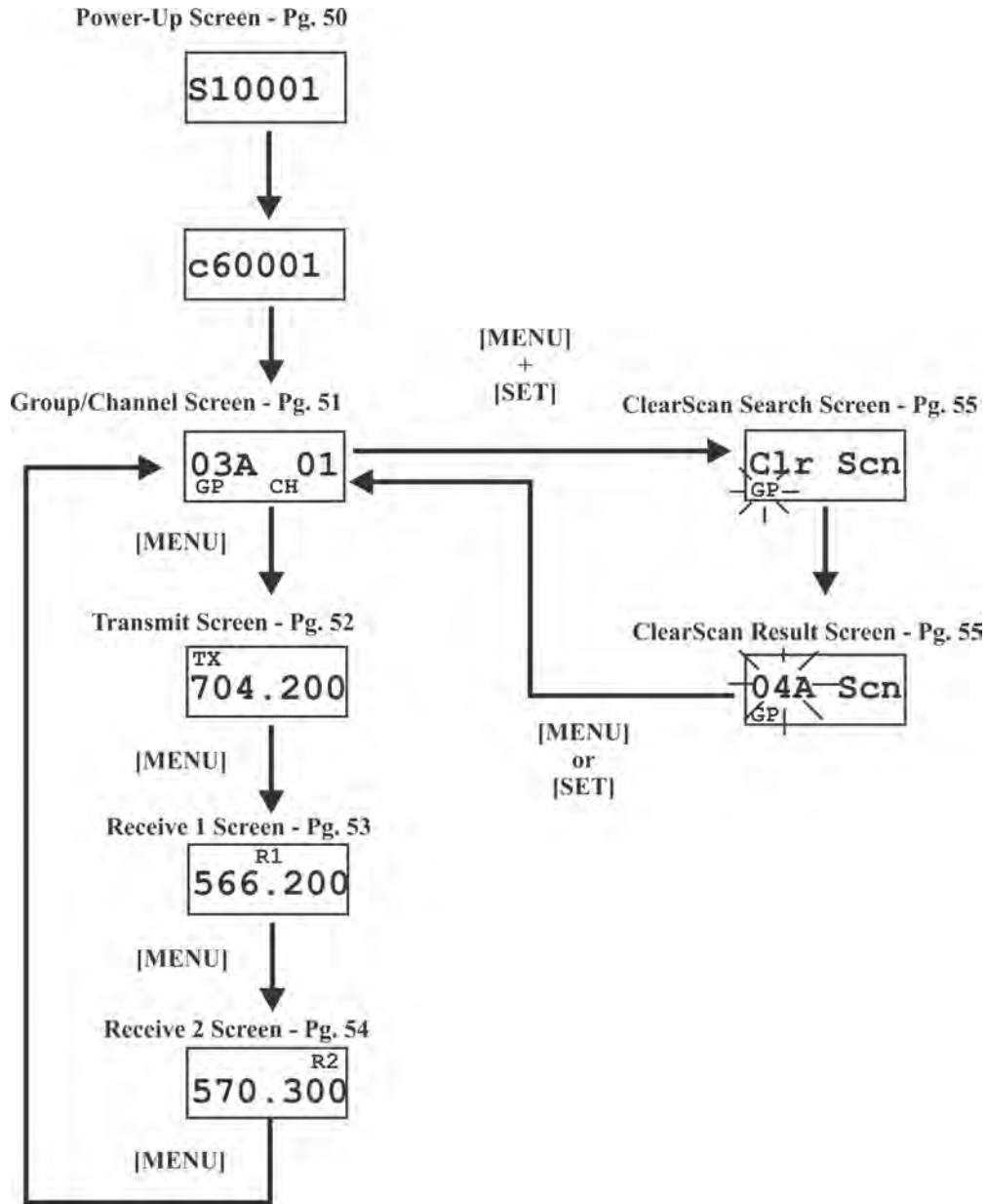
When pressed, the audio from the beltpack is disconnected from the wired intercom, auxiliary input/output and the base station’s local headset. Other beltpack users, on that audio channel, can hear the user as normal. The button activates the nearby red LED as well as the appropriate talk LED when pressed. See the “Wireless Talk Around Enable/Disable” on page 56 to learn how to enable/disable the WTA button as well as other features.

*TR-800 Menu Structure*

**Beltpack Menu Structure**

The following contains the main beltpack menu structure and references the pages in which further detail of that menu may be found.

All beltpack features and special key sequences can only be done from the group/channel screen.



**FIGURE 38. Power-Up Screen**

***Beltpack Feature Enable/Disable Menus***

- Stage Announce (SA) Enable/Disable..... page 56*
- Wireless Talk Around (WTA) Enable/Disable ..... page 56*
- Audio Channel A/B Enable/Disable..... page 57*
- Talk Button Latching/Non-Latching..... page 57*

***Other Special Key Sequences***

- Lockout..... page 58*
- 1st Use Default..... page 58*
- Factory Default..... page 58*

**NOTE:** Pressing [MENU] within a screen after action has occurred escapes from that action and places the user at the current screen. Any editing that had been done since [SET] had been pressed is aborted.

### Power-Up Screens

- The first screens displayed when the beltpack is powered up are the software and channel map version screens.
- The 1st screen displayed indicates the beltpack's software version number. It is displayed for about one second.
- The 2nd screen displayed indicates the beltpack's channel map (frequency plan) version number. It is displayed for about one second.
- The final screen displayed is the group/channel screen.

S10001



c60001



03A 01  
GP CH

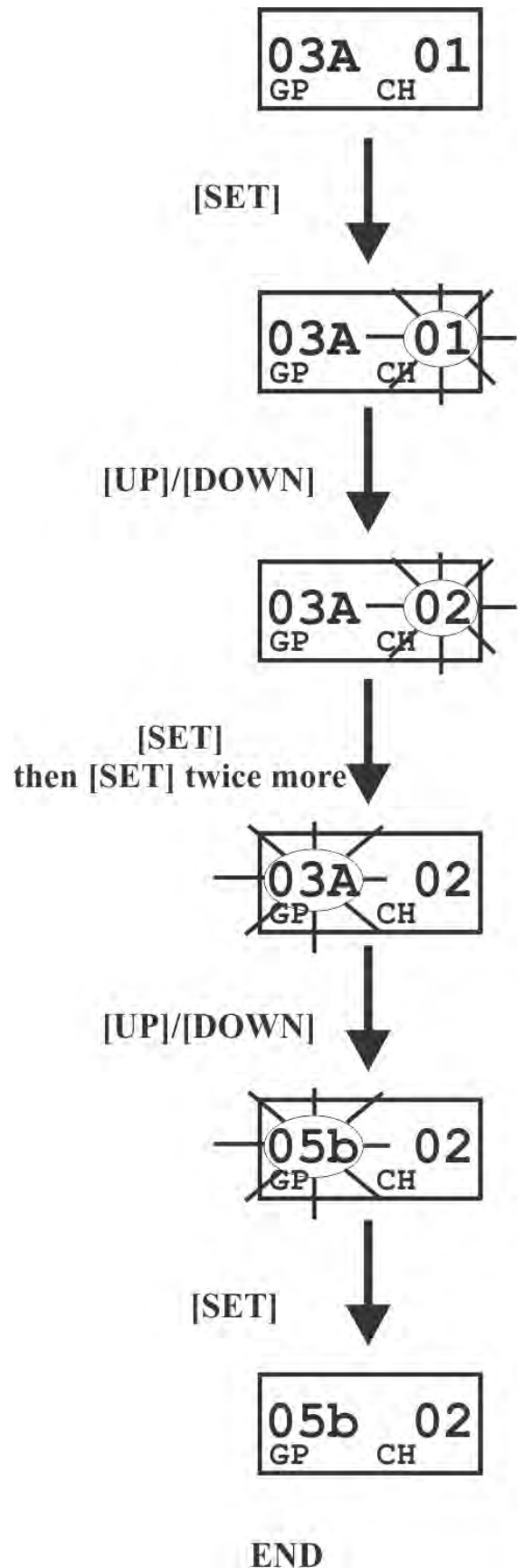
END



## Group/Channel Screen

The Group/Channel screen allows the user to change the group and select from a pre-determined number of transmit channels.

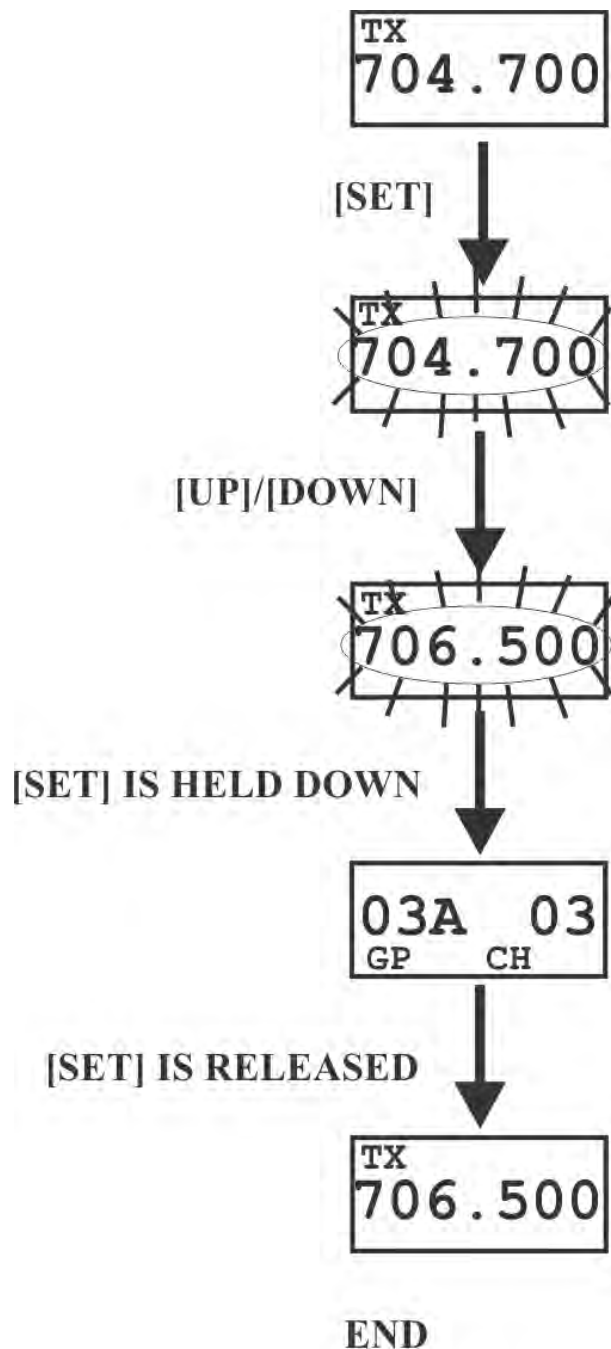
- The screen displayed after the beltpack power-up screens.
- Press [SET] to edit the channel number. The channel number will start flashing.
- Use the [UP]/[DOWN] arrow buttons to change the channel number
- Press [SET] to place the beltpack on the channel selected. Once set is pressed, the beltpack transmitter will move to that frequency and nothing will be flashing. Now press [SET] twice to enter group edit.
- Use the [UP]/[DOWN] arrow buttons to change the group number.
- Press [SET] to place the beltpack on the group selected. Once set is pressed, the unit returns to the group/channel display with nothing flashing.
- Pressing [SET] once more will start the editing sequence over again. Pressing [MENU] during the group edit will end editing and send the user back at the group/channel screen without any changes. This applies to channel editing too.



## Transmit Screen

The Transmit screen allows the user to set the beltpack transmit frequency. Factory-defined groups will allow only a set number of pre-defined frequencies to be selected. User-programmable groups will allow the user to change the frequency in 25kHz steps.

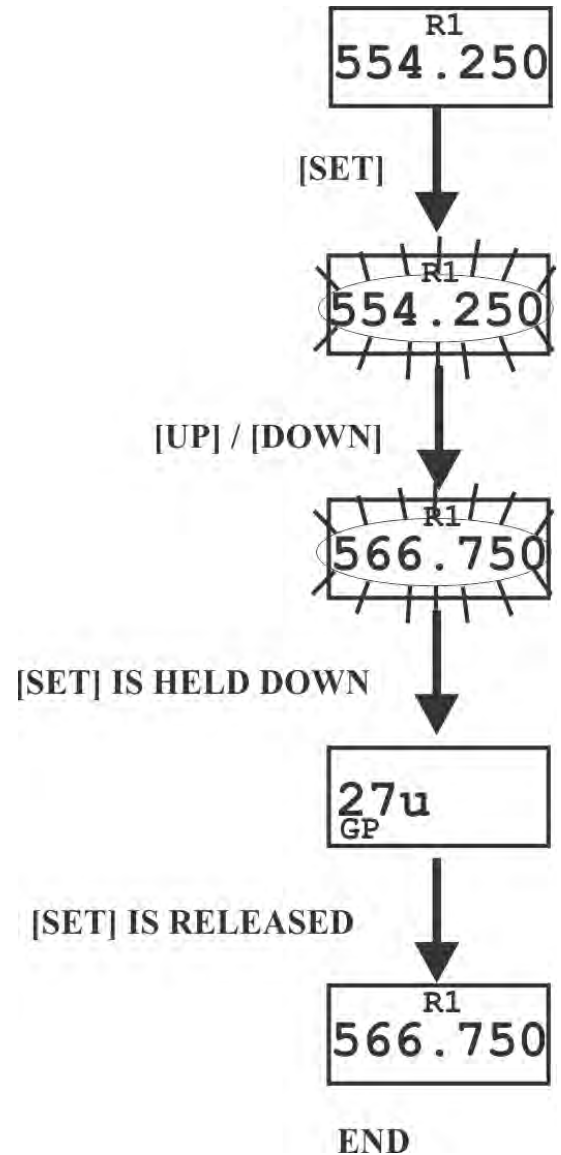
- Press [MENU] once from the group/channel screen to arrive at the transmit frequency screen.
- Press [SET] to edit the frequency. The number will start flashing.
- Use the [UP]/[DOWN] arrow buttons to change the frequency.
- Press [SET] to place the beltpack on the frequency selected. If set is held down, during that time the group/channel is displayed so the user is aware of what transmit channel the unit has been placed. Once set is released, the unit returns to the transmit frequency screen with nothing flashing.
- Pressing [SET] once more will start the editing sequence over again. Pressing [MENU] during transmit frequency edit will end editing and send the user back to the transmit screen without any changes.



## Receive 1 Screen

The Receive 1 screen allows the user to set the beltpack receive 1 frequency. This corresponds to the base station's transmit 1 frequency. In factory-defined groups, receive 1 is not changeable. User-programmable groups will allow the user to change the frequency in 25 kHz steps.

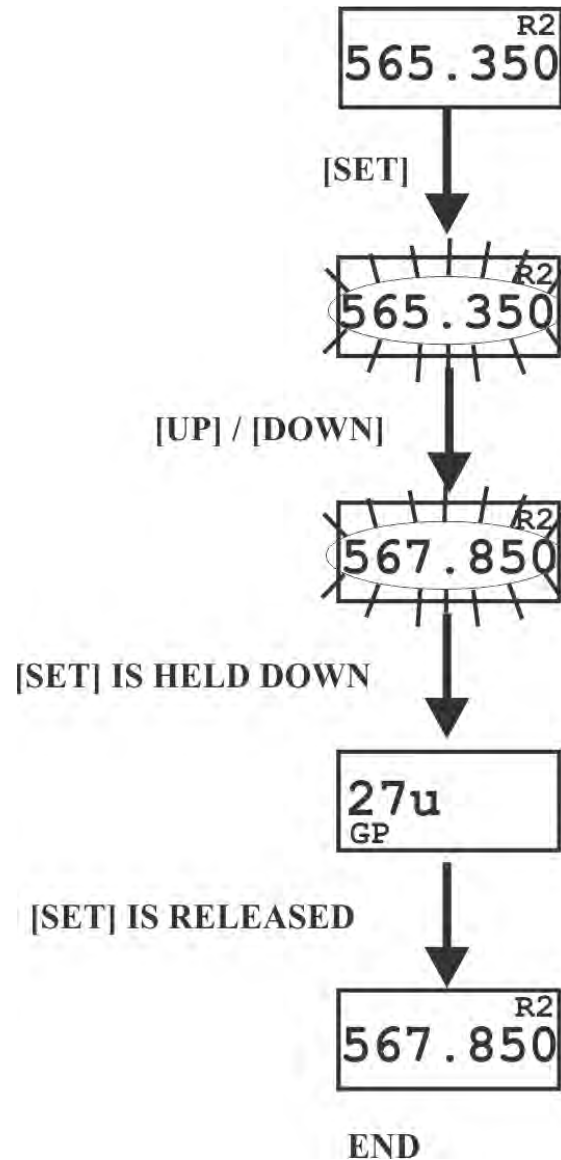
- Press [MENU] twice from the group/channel screen to arrive at the receive 1 frequency screen.
- (User-Programmable Groups Only) Press [SET] to edit the frequency. The number will start flashing. Factory-defined groups can't be changed; so pressing set will do nothing at this screen. User-programmed groups will start flashing and allow the user to change the frequency in 25 kHz steps.
- (User-Programmable Groups Only) Use the [UP]/[DOWN] arrow buttons to change the frequency.
- (User-Programmable Groups Only) Press [SET] to place the beltpack on the frequency selected. If set is held down, during that time the group is displayed so the user is aware of what group the unit has been placed. Once set is released, the unit returns to the receive 1 frequency screen with nothing flashing.
- (User-Programmable Groups Only) Pressing [SET] once more will start the editing sequence over again. Pressing [MENU] during receive 1 frequency edit will end editing and send the user back to the receive 1 screen without any changes.



## Receive 2 Screen

The Receive 2 screen allows the user to set the beltpack receive 2 frequency. This corresponds to the base station's transmit 2 frequency. In factory-defined groups receive 2 is not changeable. User-programmable groups will allow the user to change the frequency in 25 kHz steps.

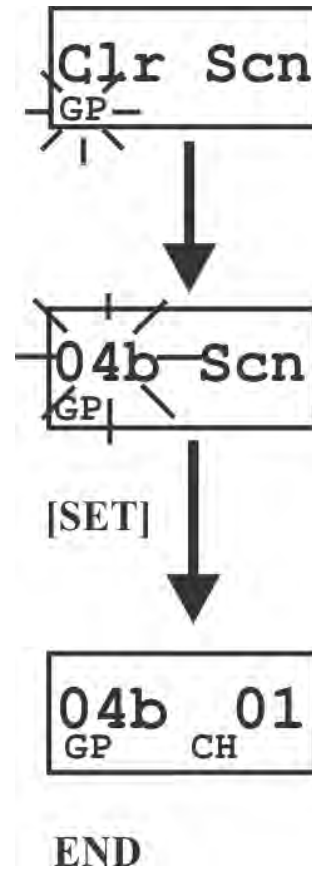
- Press [MENU] three times from the group/channel screen to arrive at the receive 2 frequency screen.
- (User-Programmable Groups Only) Press [SET] to edit the frequency. The number will start flashing. Factory-defined groups can't be changed, so pressing set will do nothing at this screen. User-programmed groups will start flashing and allow the user to change the frequency in 25 kHz steps.
- (User-Programmable Groups Only) Use the [UP]/[DOWN] arrow buttons to change the frequency.
- (User-Programmable Groups Only) Press [SET] to place the beltpack on the frequency selected. If set is held down, during that time the group is displayed so the user is aware of what group the unit has been placed. Once set is released, the unit returns to the receive 2 frequency screen with nothing flashing.
- (User-Programmable Groups Only) Pressing [SET] once more will start the editing sequence over again. Pressing [MENU] during receive 2 frequency edit will end editing and send the user back to the receive 2 screen without any changes.



### ClearScan™

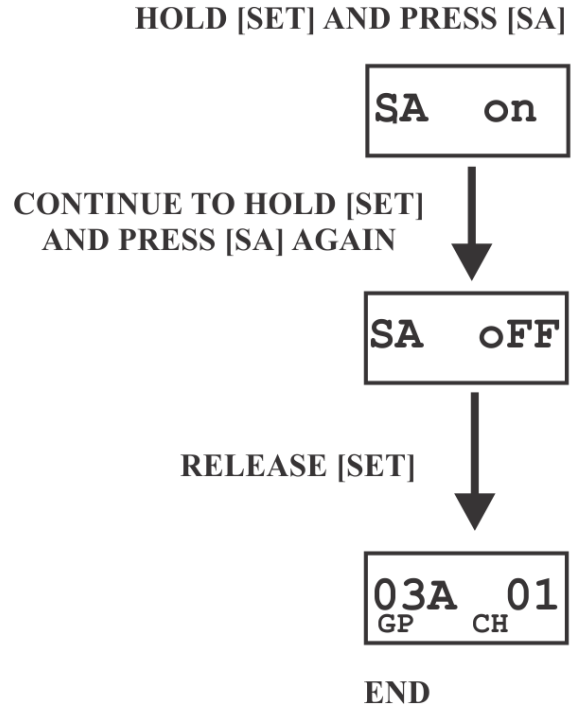
ClearScan™ performs a frequency scan of the factory-defined and any setup user-programmable groups in order to find the clearest group. After about 30 seconds, the clearest group is displayed. A group is defined by receive 1 and 2 frequencies. The next best group and so forth may be accessed with the [DOWN] and [UP] arrow buttons.

- Press and hold [MENU]+[SET] for three seconds to enter ClearScan™. The beltpack will now start searching for the clearest groups. The group symbol will flash indicating the beltpack is scanning for clear groups.
- ClearScan™ will scan all groups. It will then display the 1st group it came to that had the clearest receive channels. The [UP]/[DOWN] buttons may be used to select the next best group and so forth. Press [SET] to place the beltpack on this group and return to the group/channel screen.



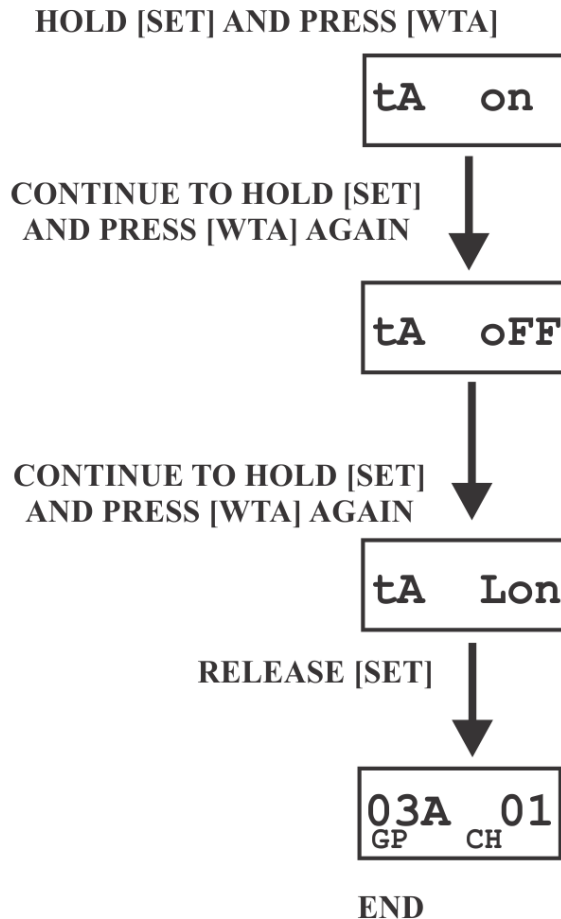
### Stage Announce Enable/Disable

- Press and hold [SET] then press the [SA] button to show the SA enable/disable screen. The current setting of the feature is displayed on the LCD.
- While continuing to hold [SET] press [SA] again to toggle the display from ON to OFF or back. Release the [SET] button to accept the current displayed setting and return to the Group/Channel screen



### Wireless Talk Around Enable/Disable

- Press and hold [SET], then press the [WTA] button to show the WTA enable/disable screen. The current setting of the feature is displayed on the LCD.
- While continuing to hold [SET] press [WTA] again to cycle the display from on, off, then L on (latch on). Release the [SET] button to accept the current displayed setting and return to the Group/Channel screen.



### Audio Channel A or B Disable/Enable

- Press and hold [SET] then press the [CHAN] button to show the channel enable/disable screen. The current setting of the feature is displayed on the LCD.
- While continuing to hold [SET], press the [CHAN] button again to move to the next option, only channel B on.
- As you continue to hold [SET], press the [CHAN] button once more to move to the next option, only channel A on. If the [CHAN] button was pressed once more, the user would start over at the AB ON screen.
- Release the [SET] button to accept the current displayed setting and return to the Group/Channel screen.

### Disabling Audio Channel A

HOLD [SET] AND PRESS [CHAN]

Ab on

CONTINUE TO HOLD [SET]  
AND PRESS [CHAN] AGAIN

b on

CONTINUE TO HOLD [SET]  
AND PRESS [CHAN] AGAIN

A on

RELEASE [SET]

03A 01  
GP CH

END

### Talk Button Latch on/Latch off

- Press and hold [SET], then press the [TALK] button to show the Talk Button Latch/Non-Latching screen. The current setting of the feature is displayed on the LCD display.
- While continuing to hold [SET] press [TALK] again to toggle the display from on to off or back. Release the [SET] button to accept the current displayed setting and return to the Group/Channel screen.

HOLD [SET] AND PRESS [TALK]

t1 on

CONTINUE TO HOLD [SET]  
AND PRESS [TALK] AGAIN

t1 oFF

RELEASE [SET]

03A 01  
GP CH

END

## Special Key Sequences

### Lockout

- Press [UP]+[DOWN] for three seconds to lock or unlock the beltack. The words “Loc on” will be displayed when the feature is activated, “Loc oFF” will be displayed when the beltack is unlocked. Pressing [MENU] will still function to view screens, but [SET] will no longer start any editing. ClearScan™, First use, Factory default and Feature enable/disable are no longer accessible.

### 1st Use Default

- Press [MENU] while turning on the beltack to enter the 1st use default setup screen. This places the unit on group 01A with channel 01 flashing. **Any user-programmed frequencies that had been entered previously are retained.** The beltacks must now be set to different transmit channels using the [UP]/[DOWN] buttons. Then [SET] is pressed to place the units on those channels. If lockout had been activated, the beltack comes up where it was last left regardless of [MENU] being pressed on power-up.

### Factory Default

- Pressing all four buttons [MENU]+[SET]+[UP]+[DOWN] at the same time for three seconds places the unit on group 01A with channel 01 flashing, just like beltack 1st use default, except the **all user-programmed frequencies that had been entered previously are erased.** After the buttons are released, it still may take several seconds for the beltack to reset. The beltacks must now be set to different transmit channels using the [UP]/[DOWN] buttons. Then [SET] is pressed to place the units on those channels. If lockout had been activated, the beltack comes up where it was last left regardless of these four keys being pressed.

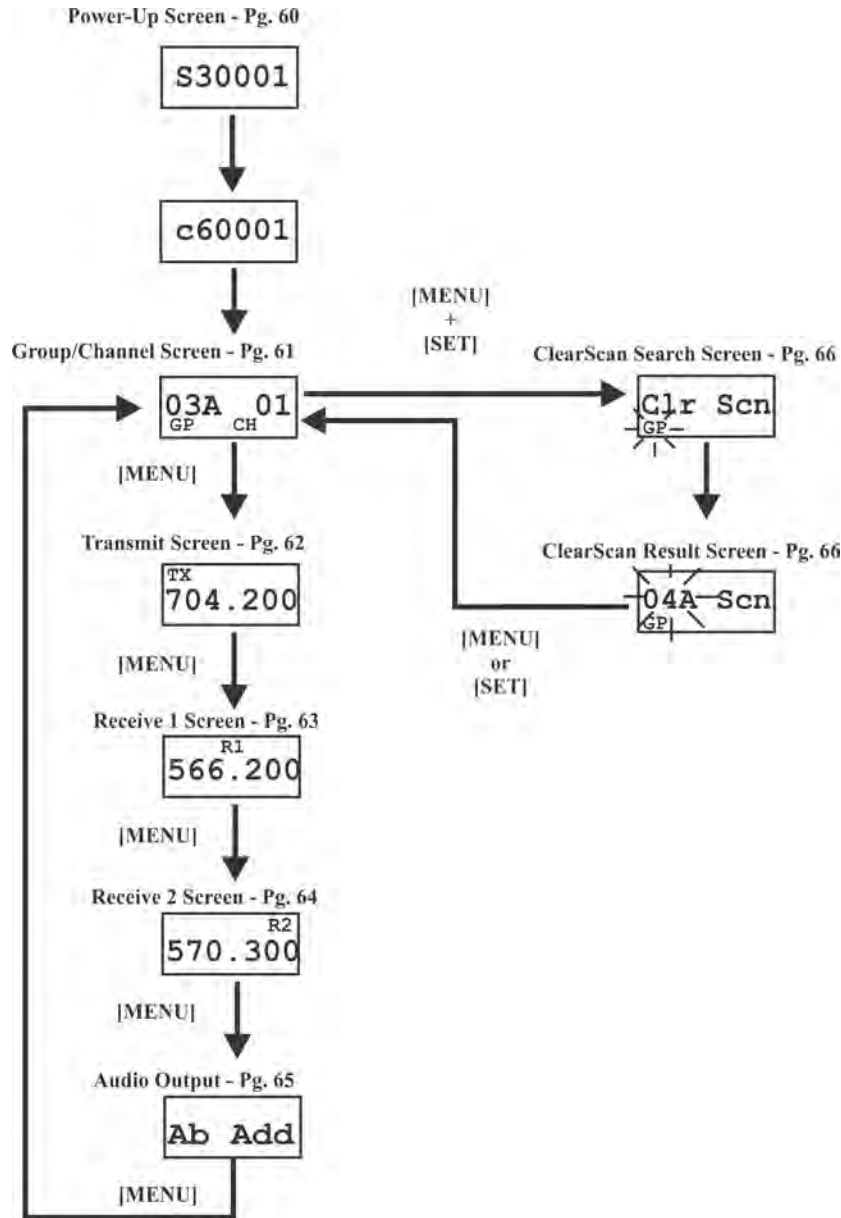


*TR-825 Menu Structure*

**Beltpack Menu Structure**

The following contains the main beltpack menu structure and references the pages in which further detail of that menu may be found.

All beltpack features and special key sequences can only be done from the group/channel screen.



**FIGURE 39. Power-Up Screen**

***Beltpack Feature Enable/Disable Menus***

- Audio Output*..... page 65
- Stage Announce (SA)*..... page 67
- Wireless Talk Around (WTA)*..... page 68
- Audio Channel A*..... page 69
- Audio Channel B*..... page 70

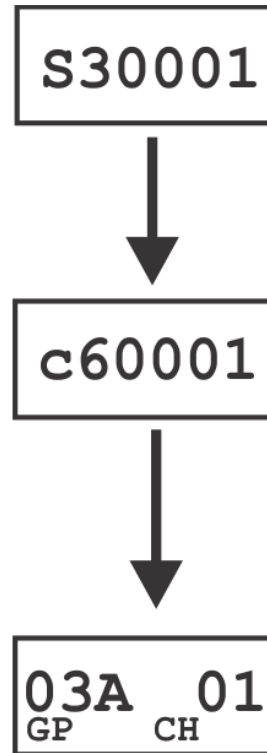
***Other Special Key Sequences***

- Lockout*..... page 71
- 1st Use Default*..... page 71
- Factory Default*..... page 71

**NOTE:** Pressing [MENU] within a screen after action has occurred escapes from that action and places the user at the current screen. Any editing that had been done since [SET] had been pressed is aborted.

### Power-Up Screens

- The first screens displayed when the beltpack is powered up are the software and channel map version screens.
- The 1st screen displayed indicates the beltpack's software version number. It is displayed for about one second.
- The 2nd screen displayed indicates the beltpack's channel map (frequency plan) version number. It is displayed for about one second. The operating screen is then displayed.
- The final screen displayed is the group/channel screen.

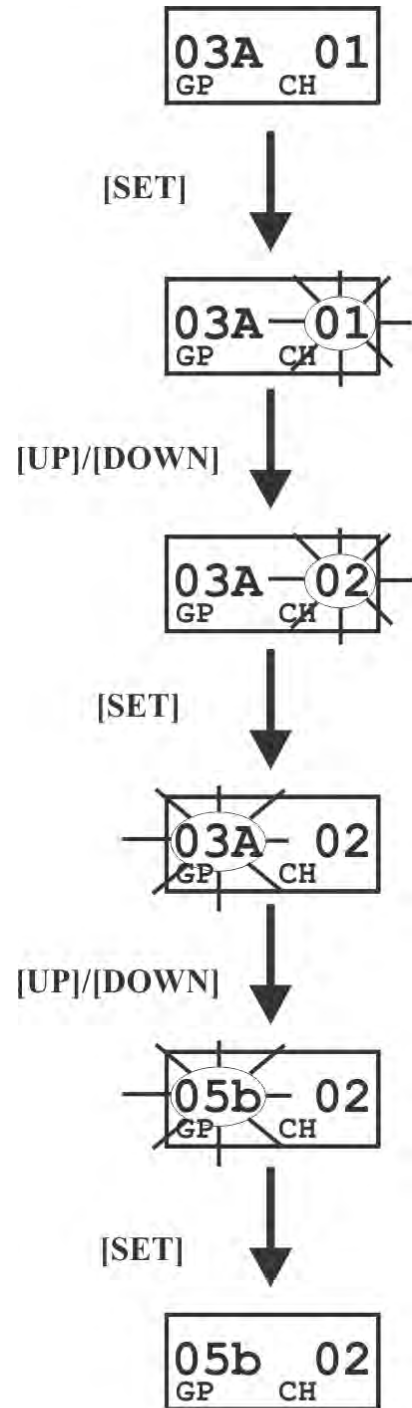


**END**

## Group/Channel Screen

The Group/Channel screen allows the user to change the group and select from a pre-determined number of transmit channels.

- The screen displayed after the beltpack power-up screens.
- Press [SET] to edit the channel number. The channel number will start flashing.
- Use the [UP]/[DOWN] arrow buttons to change the channel number.
- Press [SET] to place the beltpack on the channel selected. Once set is pressed, the beltpack transmitter will move to that frequency and nothing will be flashing. Now press [SET] twice to enter group edit.
- Use the [UP]/[DOWN] arrow buttons to change the group number.
- Press [SET] to place the beltpack on the group selected. Once set is pressed, the unit returns to the group/channel display with nothing flashing.
- Pressing [SET] once more will start the editing sequence over again. Pressing [MENU] during the group edit will end editing and send the user back at the group/channel screen without any changes. This applies to channel editing also.

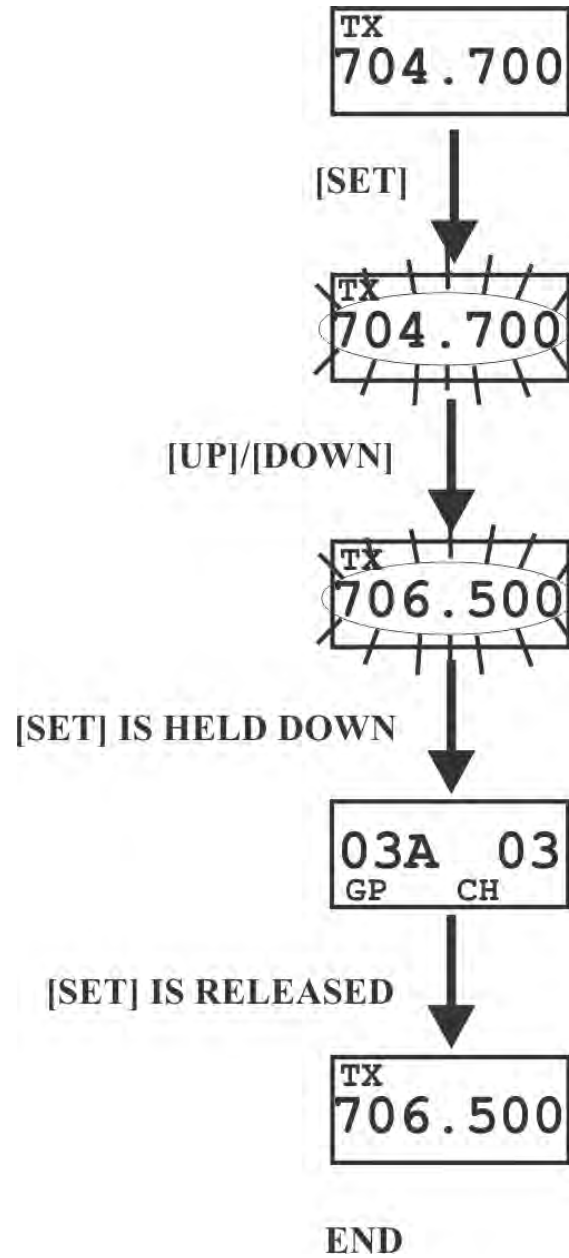


END

## Transmit Screen

The Transmit screen allows the user to set the beltpack transmit frequency. Factory-defined groups will allow only a set number of pre-defined frequencies to be selected. User-programmable groups will allow the user to change the frequency in 25 kHz steps.

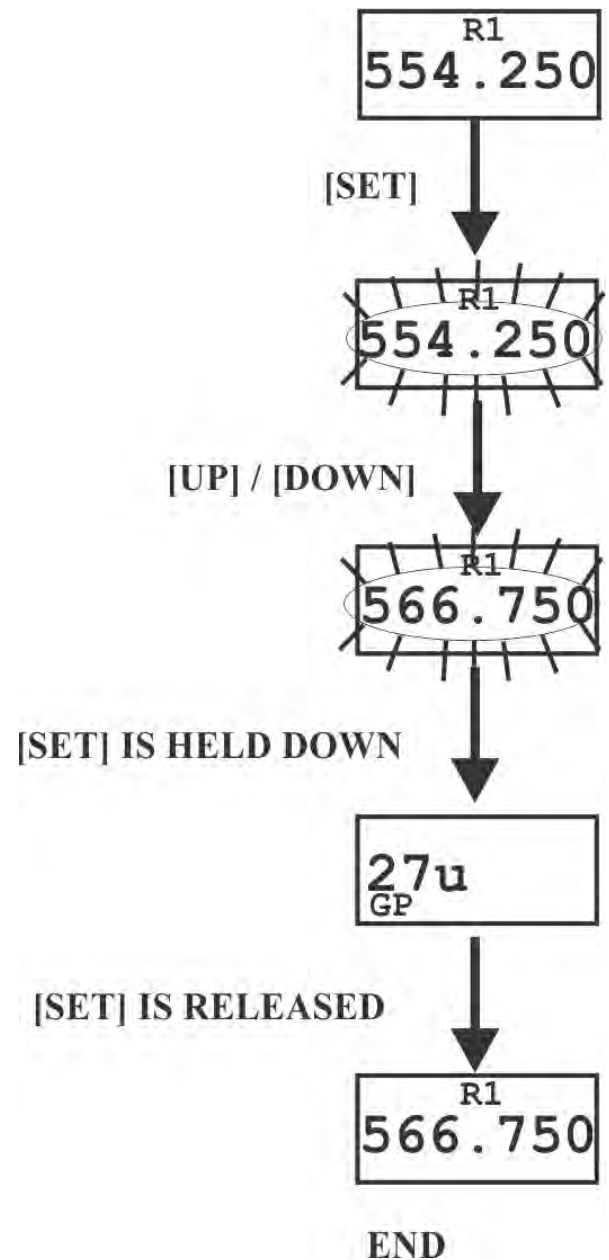
- Press [MENU] once from the group/channel screen to arrive at the transmit frequency screen.
- Press [SET] to edit the frequency. The number will start flashing. Factory-defined groups will allow only a set number of pre-defined frequencies to be selected. User-programmable groups will allow the user to change the frequency in 25 kHz steps.
- Use the [UP]/[DOWN] arrow buttons to change the frequency.
- Press [SET] to place the beltpack on the frequency selected. If [SET] is held down, during that time the group/channel is displayed so the user is aware of what transmit channel the unit has been placed. Once [SET] is released, the unit returns to the transmit frequency screen with nothing flashing.
- Pressing [SET] once more will start the editing sequence over again. Pressing [MENU] during transmit frequency edit will end editing and send the user back to the transmit screen without any changes.



## Receive 1 Screen

The Receive 1 screen allows the user to set the beltpack receiver 1 frequency. This corresponds to the base station's transmit 1 frequency. In factory-defined groups receiver 1 is not changeable. User-programmable groups will allow the user to change the frequency in 25 kHz steps.

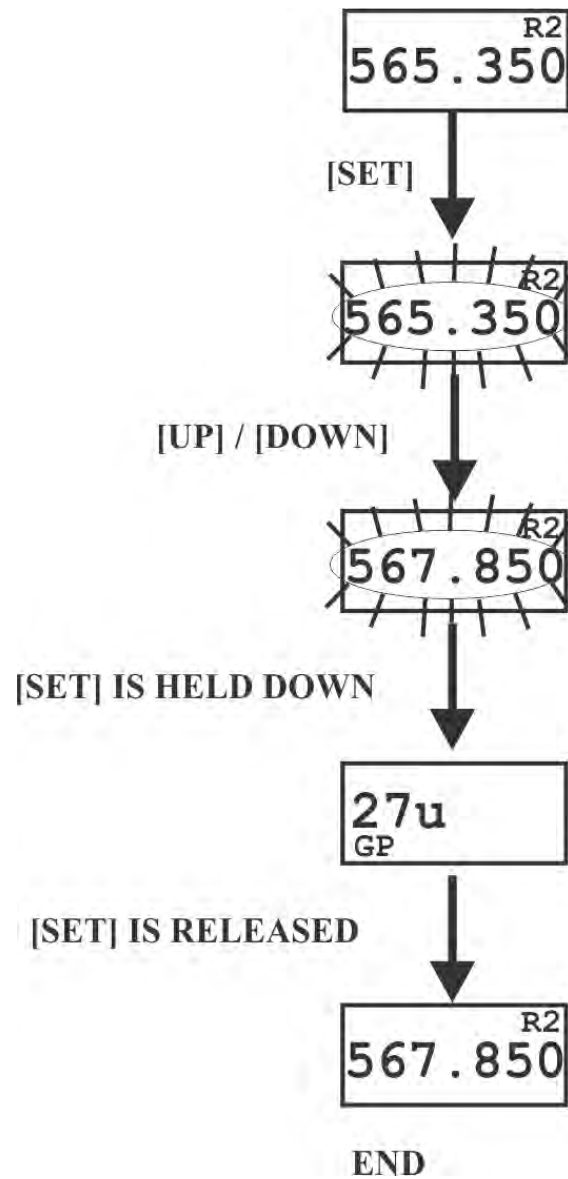
- Press [MENU] twice from the group/channel screen to arrive at the receive 1 frequency screen.
- (User-Programmable Groups Only) Press [SET] to edit the frequency. The number will start flashing. Factory-defined groups can't be changed; so pressing set will do nothing at this screen. User-programmed groups will start flashing and allow the user to change the frequency in 25 kHz steps.
- (User-Programmable Groups Only) Use the [UP]/[DOWN] arrow buttons to change the frequency.
- (User-Programmable Groups Only) Press [SET] to place the beltpack on the frequency selected. If [SET] is held down, during that time the group is displayed so the user is aware of what group the unit has been placed. Once [SET] is released, the unit returns to the receive 1 frequency screen with nothing flashing.
- (User-Programmable Groups Only) Pressing [SET] once more will start the editing sequence over again. Pressing [MENU] during receive 1 frequency edit will end editing and send the user back to the receive 1 screen without any changes.



## Receive 2 Screen

The Receive 2 screen allows the user to set the beltpack receive 2 frequency. This corresponds to the base station's transmit 2 frequency. In factory-defined groups receiver 2 is not changeable. User-programmable groups will allow the user to change the frequency in 25 kHz steps.

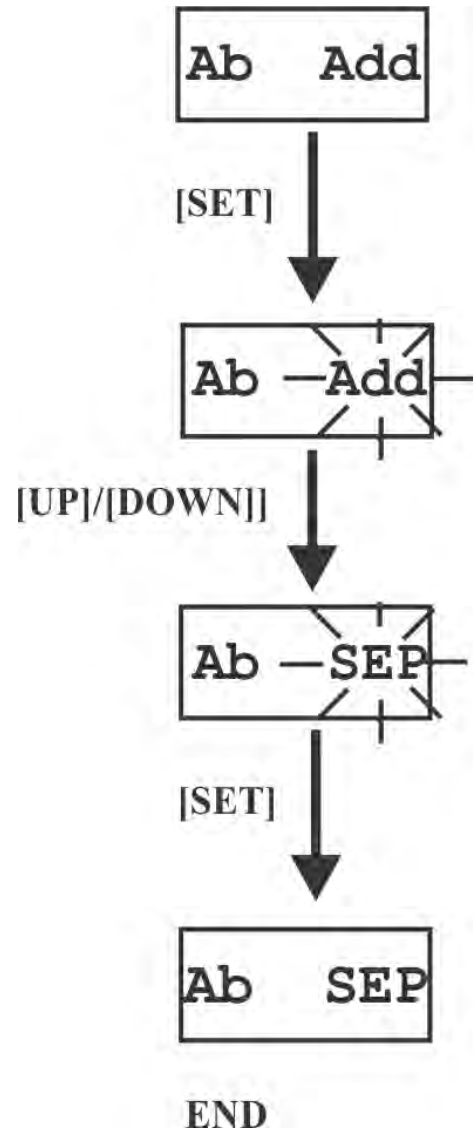
- Press [MENU] three times from the group/channel screen to arrive at the receive 2 frequency screen.
- (User-Programmable Groups Only) Press [SET] to edit the frequency. The number will start flashing. Factory-defined groups can't be changed, so pressing [SET] will do nothing at this screen. User-programmed groups will start flashing and allow the user to change the frequency in 25 kHz steps.
- (User-Programmable Groups Only) Use the [UP]/[DOWN] arrow buttons to change the frequency.
- (User-Programmable Groups Only) Press [SET] to place the beltpack on the frequency selected. If [SET] is held down, during that time the group is displayed so the user is aware of what group the unit has been placed. Once [SET] is released, the unit returns to the receive 2 frequency screen with nothing flashing.
- (User-Programmable Groups Only) Pressing [SET] once more will start the editing sequence over again. Pressing [MENU] during receive 2 frequency edit will end editing and send the user back to the receive 2 screen without any changes.



## Audio Output

The Audio Output screen allows the user to set the audio output to Mono (Add) or Stereo (SEP). This option only applies to beltpack with 5-pin headset connectors. Single-sided 5-pin headsets will only receive A or B Audio depending on how the headset is wired. Single-sided 5-pin headsets must set the audio output to Ab SEP. The audio output option setting does nothing with a 4-pin headset connector.

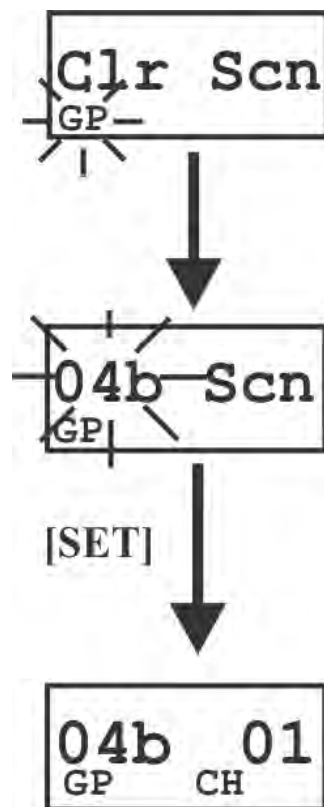
- Press [MENU] four times from the group/channels screen to arrive at the audio output screen.
- Press [SET] to change the setting. The option will start to flash.
- Use the [UP]/[DOWN] arrow buttons to change the audio output option.
- Press [SET] to end editing and accept the setting.



### ClearScan™

ClearScan™ performs a frequency scan of the factory-defined and any set up user-programmable groups in order to find the clearest group. After about 30 seconds, the clearest group is displayed. A group is defined by receive 1 and 2 frequencies. The next best group and so forth may be accessed with the [DOWN] and [UP] arrow buttons.

- Press and hold [MENU]+[SET] for three seconds to enter ClearScan™. The beltpack will now start searching for the clearest groups. The group symbol will flash indicating the beltpack is scanning for clear groups.
- ClearScan™ will scan all groups. It will then display the 1st group it came to that had the clearest receive channels (lowest RSSI levels on the two frequencies). The [UP]/[DOWN] buttons may be used to select the next best group and so forth. Press [SET] to place the beltpack on this group and return to the group/channel screen.



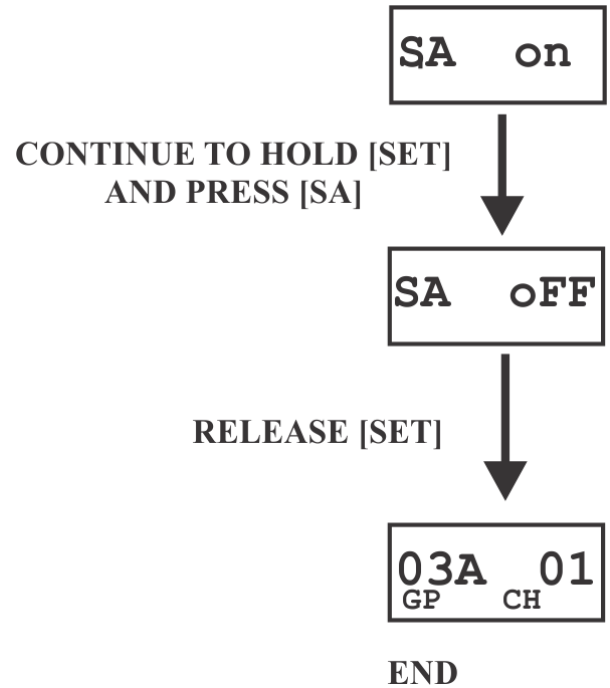
**END**



**Stage Announce Enable/Disable**

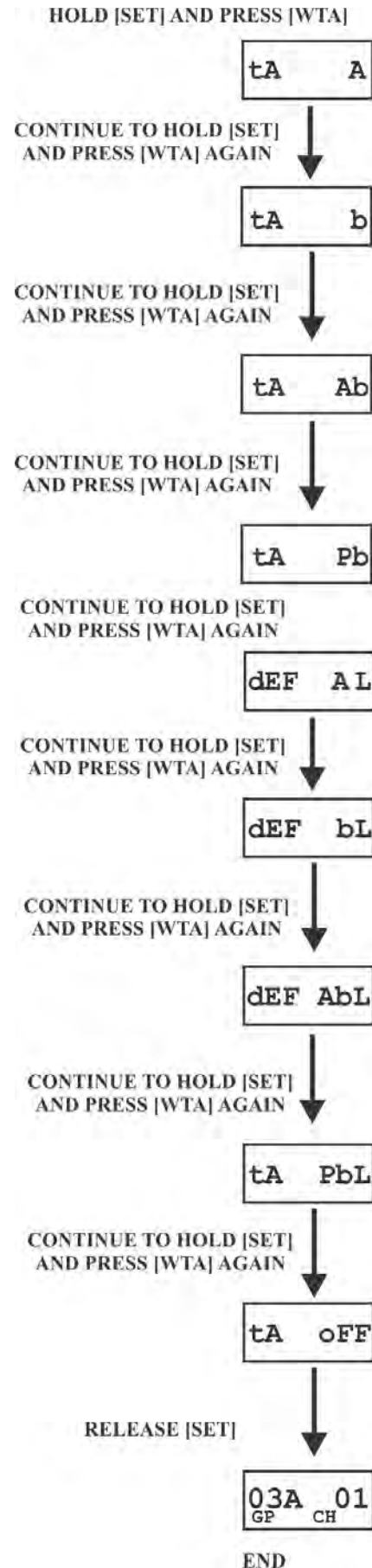
- Press and hold [SET] then press the [SA] button to show the SA enable/disable screen. The current setting of the feature is displayed on the LCD display.
- While continuing to hold [SET] press [SA] again to toggle the display from ON to OFF or back. Release the [SET] button to accept the current displayed setting and return to the Group /Channel screen.

**NOTE:** When SA is enabled and pressed, whatever is on; A talk, B talk, or both goes out. No audio channels show active when SA is pressed.



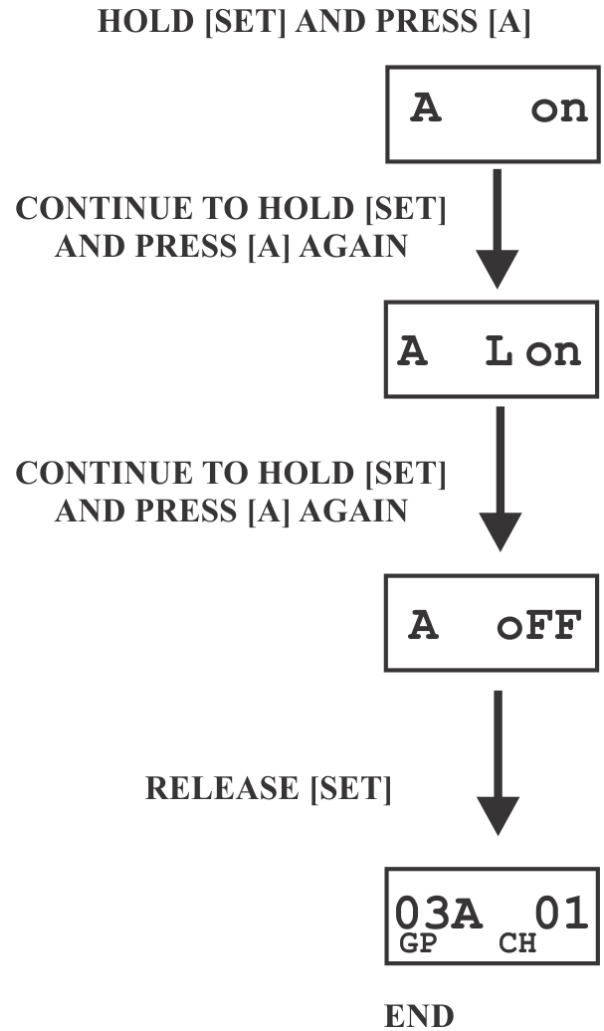
## Wireless Talk Around

- Press and hold [SET] then press the [WTA] button to show the WTA menu screen. The current setting of the feature is displayed on the LCD display. The first screen to the right is currently set to a default of A channel, non-latching.
- While continuing to hold [SET] press [WTA] again to go to the next selection; Talk Around = B channel, non-latching.
- Talk Around = A+B channels, non-latching.
- Talk Around = Push-Button, non-latching. Whatever talk button is active becomes wireless talk around.
- Talk Around = A channel, latching.
- Talk Around = B channel, latching.
- A+B channels, latching.
- Talk Around = Push-Button, latching. Whatever talk button is active becomes wireless talk around.
- While continuing to hold [SET], press [SA] once again to display the final menu option Talk Around = Off. Release the [SET] button on any of the above screens to accept the current displayed setting and return to the Group/Channel screen.



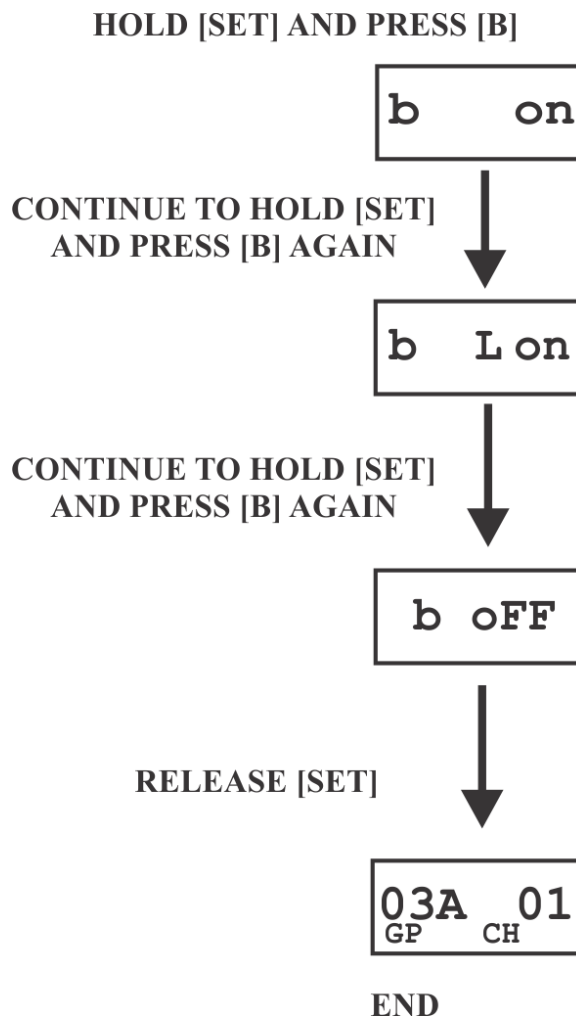
### Audio Channel A Options

- Press and hold [SET] then press [A] button to show the channel A menu screen. The current setting of the button is displayed on the LCD display; Channel A Talk-Latching Off.
- While continuing to hold [SET], press the [A] button again to move to the next option; Channel A Talk-Latching On.
- As you continue to hold [SET], press the [A] button once more to move to the next option, Channel A Off.
- Release the [SET] button to accept the current displayed setting and return to the Group/Channel screen.



## Audio Channel B Options

- Press and hold [SET] then press the [B] button to show the channel B menu screen. The current setting of the button is displayed on the LCD display; Channel B Talk-Latching Off.
- While continuing to hold [SET], press the [B] button again to move the next option; Channel B Talk-Latching On.
- As you continue to hold [SET], press the [B] button once more to move to the next option, Channel B Off.
- Release the [SET] button to accept the current displayed setting and return to the Group/Channel screen.



## Special Key Sequences

### Lockout

- Press [UP]/[DOWN] for three seconds to lock or unlock the beltack. The words “Loc on” will be displayed when the feature is activated, “Loc off” will be displayed when the beltack is unlocked. Pressing [MENU] will still function to view screens, but [SET] will no longer start any editing. ClearScan™, First use, Factory default, and Feature enable/disable are no longer accessible. The words “Loc out” will be flashed on the screen if any editing is attempted during lockout.

### 1st Use Default

- Press [MENU] while turning on the beltack to enter the 1st use default setup screen. This places the unit on group 01A with channel 01 flashing. **Any user-programmed frequencies that had been entered previously are retained.** The beltacks must now be set to different transmit channels using the [UP]/[DOWN] buttons. Then the [SET] button is pressed to place the units on those channels. If lockout had been activated, the beltack comes up where it was last left regardless of [MENU] being pressed on power-up.

### Factory Default

- Pressing all four buttons [MENU]+[SET]+[UP]+[DOWN] at the same time places the unit on group 01A with channel 01 flashing, just like beltack 1st use default, except the **all user-programmed frequencies that had been entered previously are erased.** The beltacks must now be set to different transmit channels using the [UP]/[DOWN] buttons. Then [SET] is pressed to place the units on those channels. If lockout had been activated, the beltack comes up where it was last left regardless of these four keys being pressed.



## System Walk-Thru

---

Now that you have successfully set up your RTS Wireless Intercom System and turned on any auxiliary equipment, you are ready to test the overall performance by walking the RTS system through the areas in which you will be using it.

Before you begin your walk-thru, check the following:



Beltpack Battery Check.



Set microphone gain in both the beltpack(s) and the base station.



The base station and beltpack(s) are on the same group and the beltpack(s) are on their own unique transport channels that match the base station receive channels.



Check that the talk button is engaged.  
The talk LED will be illuminated.



Intercom Level IN and OUT are set to an appropriate level.



Auxiliary Level IN and OUT are set to an appropriate level (if used).

The system walk-thru can detect the problem of weak signal strength caused by:

- Poor antenna location
- Wrong antenna for receiver and/or transmitter
- RF trouble spots
- Operating distance beyond system capability
- Old or used batteries in the TR-8XX

Under normal conditions, the base station's display will indicate a beltpack status. Weak Signal condition will result in "no tx" being displayed on the base station's receiver for that beltpack.

In 99% of all instances you will set up your RTS Wireless Intercom System, walk it through the area of interest and achieve error-free performance. If in the rare instance, your RTS system does not pass during your walk-thru evaluation, refer to the section of this manual which deals with System Troubleshooting.





# Troubleshooting

Reread the sections of this manual to make sure you have completed system set up properly

If you are unable to solve the problem, contact the dealer from whom you purchased the system for assistance.

PROBLEM	SOLUTION
<b>DISTORTION</b> - System's audio quality seems distorted at medium to high input levels.	Reduce microphone gain by adjusting microphone gain control.
<b>HISS</b> - System seems to produce a "hiss" which is undesirable.	Check the gain setting on all beltacks and the base. They may be too low or too high. Check to make sure you are still well within range of the base station.
<b>LOW OUTPUT</b> - System produces a low output level.	Check the gain setting on both the beltacks and the base. They may be too low.
<b>FEEDBACK</b> - Moving around area of use produces "squeal" or "howl" in various locations using ext. speakers.	Reduce the gain settings on both the beltacks and the base. They may be too high.
<b>DROPOUTS</b> - When moving around the area of use there seems to be locations where the signal swooshes or completely disappears	Make sure both antennas on the base and beltack are connected and follow the location suggestions. Change the location of the base unit and antennas or avoid the bad areas with the remote beltacks.
<b>INTERFERENCE</b> - System picks up signals other than wireless intercoms.	Make sure that all the RTS beltack(s) are on. If there are any unused receivers at the base, turn the audio off from those receivers by deselecting the appropriate Portable Station Connect button. If problems persist with the beltack on, you will probably need to change the group. Make sure the base and beltack match after any Group/Channel change.
<b>NO AUDIO</b> from BASE or BELTPACK headsets.	Check Transmitter switch on base and beltack. Check talk LED to make sure it is on. Make sure beltack batteries are OK.
<b>BASE and BELTPACK'S Frequencies Don't Match</b> - In the display frequencies screen of the base and the menu of the beltack the frequencies don't match.	Ensure the units are on the correct Group and Channels. If three band base and beltack units and in the US make sure you have switched the base station to the US channel map, see "Troubleshooting" on page 75.

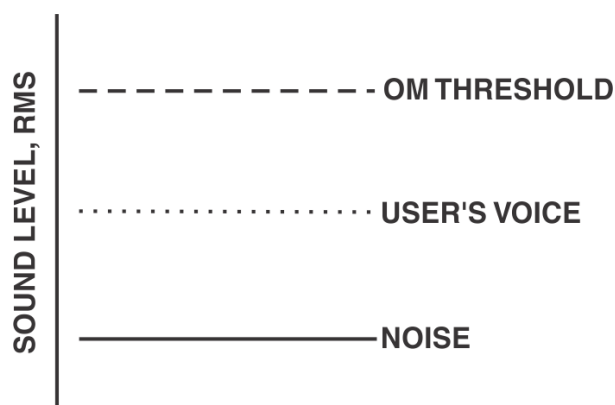


### Frequency Interaction

Unfortunately, radio frequency (RF) channels cannot be randomly selected for use in radio devices. They must be selected to avoid known frequencies in use, FCC restrictions on the location of devices, and even interference between your own RF devices. The factory defined frequencies (Groups 01A-24) selected by RTS for this wireless system are chosen to minimize possible interference.

### Microphone Gain Adjustment

The microphone gain controls on the base station and beltpack are set to mid-levels by the factory. In most cases this setting will work fine and only on loud speech will the over-modulation (OM) indicator light. However, in environments where the background noise is loud or the user has a strong/quiet voice, the gain control will need to be adjusted. In Figure 40 the gain is set correctly. The user's root-mean-square (RMS) sound level is well below the OM threshold and only on peaks does his or her voice flash the OM indicator light.

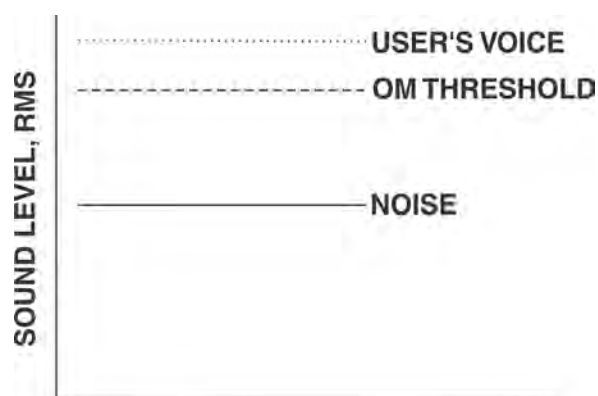


**FIGURE 40.** Low Noise Environment Microphone Gain Set Correctly

Figure 41 displays the same gain setting as in Figure 40 but brought into a high noise environment. The user's voice now lights the OM indicator all the time he or she speaks due to the higher noise plus the user speaking louder. The result on the

system is distortion on louder speech. The microphone gain must be reduced. The same applies to a user with a powerful voice. If someone sets the system mic gain to their voice and user has a much stronger voice, then the gain will need to be reduced, even if the background noise is the same.

Always remember to set the microphone gain based on the situation and location in which the equipment will be used. If the equipment is used on the field during a football game, set the gain based upon a loud stadium, NOT a quiet stadium 2 hours before a game. If a production studio user has a quiet voice, set the gain to their voice and NOT the stage hand's loud voice who helped set up the system.



**FIGURE 41.** High Noise Environment Microphone Gain Set Too High



## Battery Information

Improper battery selection, use, installation and care are the cause of numerous wireless system failures.

**Alkaline Batteries:** Alkaline batteries such as Eveready's ENERGIZER®<sup>1</sup> and ENERGIZER INDUSTRIAL provide the most reliable operation in wireless transceivers.

**The use of low cost carbon-zinc batteries is NOT recommended.**

**Nickel-Metal Hydride Batteries** - These batteries can save you money in the long run, as they can be recharged. Typical battery life is a little less than the length of time alkaline batteries last.

### Cold Temperatures and Batteries

The battery life times listed in this section are at room temperature. Alkaline and Nickel-Metal Hydride battery service hours fall off significantly at low temperature due to battery chemistry. Alkaline batteries typically have less than half their room temperature service life if used at freezing 32° F (0° C). If you use Alkaline and Nickel-Metal Hybrid batteries at low temperatures, you need to change them more often.

Another solution is using Lithium AA cells if belt packs are to be used in very cold temperatures. Lithium batteries, like the Energizer Ultimate Lithium AA cells, are excellent batteries for cold temperatures. At 15° F (-9° C), Lithium AA cells will last about seven times longer than Alkaline batteries. This equates to two hours for Alkaline vs. 14 hours for Lithium. However, the trade off is Lithium batteries cost more and are less environmentally-friendly than Alkaline batteries.

### Battery Life:

TR-800  
Alkaline, 11-13 hours, typical  
Nickel Metal Hydride, 10-12 hours, typical

TR-825  
Alkaline, 8-10 hours, typical  
Nickel Metal Hydride, 7-9hours, typical

### Battery Warnings

- Do not place alkaline battery packs in any battery charger. Severe charger and battery pack damage may occur.
- Batteries that have been dropped, or otherwise damaged, should not be used and should be discarded properly.
- Dropping batteries can crack the internal casing causing leakage or rupture resulting in personal injury or property damage!
- Insert batteries properly, with the plus (+) and minus (-) terminals aligned correctly!
- Do not mix old and new batteries, batteries of different types, or batteries of different brands. This can cause leakage or rupture, resulting in personal injury or property damage!
- Immediately remove exhausted batteries from the battery pack and dispose of properly.
- Replace all used batteries in your device at the same time.
- Do not put batteries or battery-powered devices in very warm places. Extreme temperatures reduce battery performance and may also lead to leakage.
- Use only high quality AA-sized batteries in the battery packs.
- When not in use, disconnect battery pack, remove and store batteries in a cool, dry place at normal room temperature until ready to use.
- Keep battery contact surfaces clean by gently rubbing with a clean pencil eraser or cloth.

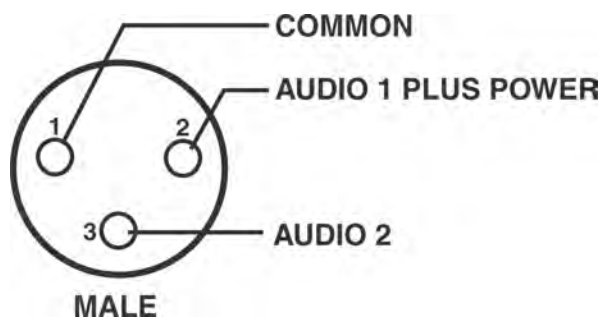
1. Energizer® is a registered trade mark of Union Carbide Corporation.



# Intercom Systems Specifications

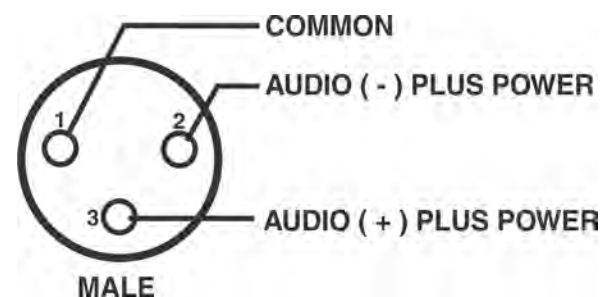
## RTS

Input Impedance:	200 $\Omega$
Output Level:	0.775 Vrms nominal
Bridging Impedance:	>10kW
Call Signaling:	
Send:	20 kHz $\pm$ 100 Hz, 240 mVrms
Receive:	20 kHz $\pm$ 800 Hz, 100 mVrms
Power Voltage:	28.0 VDC nominal



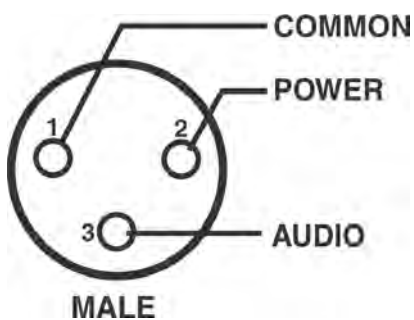
## Audiocom/Telex

Input Impedance:	300 $\Omega$
Output Level:	1.0 Vrms nominal
Bridging Impedance:	>10kW
Call Signaling:	
Send:	20 kHz $\pm$ 100 Hz, 05 mVrms
Receive:	20 kHz $\pm$ 800 Hz, 100 mVrms
Power Voltage:	24.0 VDC nominal



## Clear-Com

Input Impedance:	200 $\Omega$
Output Level:	1.0 Vrms nominal
Bridging Impedance:	>10kW
Call Signaling:	
Send:	12 $\pm$ 3VDC
Receive:	4 VDC minimum
Power Voltage:	30.0 VDC nominal







## Accessories and Replacement Parts

### ALP-600

520-760 mHz Bi-Directional Log Periodic Antenna  
Includes mounting hardware and 10 feet (3 meters) of  
coaxial cable with TNC Connectors.

PN 878896

### ALP-450

450-900 mHz Log Periodic Antenna  
Includes mounting hardware and 10 feet (3 meters) coaxial  
cable with TNC connectors.

Order No. 71147000

### Antenna Cables

Special low loss antenna cables with TNC Connectors

Model No.	Length	Order No.
CXU-10	10 Ft (3 meters)	690419
CXU-25	25 Ft (7.6 meter)	71151-025
CXU-50	50 Ft (15 meter)	71151-050
CXU-75	75 Ft (23 meter)	71151-075
CXU-100	100 Ft (30 meter)	71151-100

### AB-2

Bracket for 1/2-wave Antenna with 10ft. of coax

PN 71138000

### BTR Power Cords

North America	550024013
U.K.	550024002
European	550024000
Australian	550024018

### BTR Intercom Dummy Load

Audiocom (TELEX) type	PN 878935
RTS type	PN 878990

SA Relay screw plug  
adapter PN 2862046

TR LCD/switch cover PN 450364

### BP-700 TR Battery pack, alkaline

(batteries not included) PN 71315-000

### BP-800NM TR Nickel-Metal Hydride 2200mAh

Battery pack PN 71315-002

### BC-800NM4

Four Slot "Smart"  
Charger with Nickel Metal  
Hydride Battery Packs

US/Canada PRD00007008

EURO PRD00007009

### BC-800NM

Single Slot "Smart"  
Charger with Nickel Metal  
Hydride Battery Packs

US/Canada PRD00007006

EURO PRD00007007







## Certification Information

### FCC

The RTS BTR-800, TR-800, and the TR-825 Transmitter/Receiver are Type Accepted under United States Federal Communications Commission Part 74. Part 74 licensing of the equipment is the User's responsibility and licensibility depends on the user's classification, users application, and frequency selected. Bosch strongly urges the user to contact the appropriate telecommunications authority for any desired clarification.

The device complies with Part 15 of the FCC Rules. this device complies with part 15 of the FCC Rules. Operation is subject to the following tow conditions: (1) This device may not cause harmful interference, and (2) this device must accept any interference that may cause undesired operation.

---

**CAUTION:** Changes or modifications made by the user could void the user's authority to operate the equipment.

---

**NOTE:** This wireless microphone system can be configured for both FCC Part 15 (unlicensed) and FCC Part 74 (licensed) operation. When shipped from the factory, this wireless microphone system is configured for unlicensed operation, and will operate at a power level not to exceed 50 milliwatts, which meets FCC Part 15 requirements. If unlicensed users operate this device in excess of 50 milliwatts, harmful interference may result and the unlicensed user will be subject to substantial monetary forfeitures and other FCC sanctions. The wireless microphone system may be operated by holders of a valid FCC license in the Low Power Auxiliary Radio Service under Part 74 of FCC Rules, at power levels between 50 milliwatts and 250 milliwatts.

### Mandatory Safety Instructions to Base Station Installers and Users

1. Use only manufacturer or dealer supplied antenna. Antenna minimum safe distance, as calculated from FCC requirements, is 4.8 cm. However, the FCC default for the minimum safe distance is 20 cm. Antenna gain: zero dBd referenced to a dipole.
2. The FEDERAL COMMUNICATIONS COMMISSION has adopted a safety standard for human exposure to RF (Radio Frequency) energy, which is below the OSHA (Occupational Safety and Health Act) limits.
3. To comply with current FCC RF Exposure limits, the antenna must be installed at or exceeding the minimum safe distance shown here, and in accordance with the requirements of the antenna manufacturer or supplier.
4. Antenna substitution: Do Not substitute any antenna for the one supplied by or recommended by the manufacturer or radio dealer. You may be exposing person or persons to harmful radio frequency radiation. You may contact your radio dealer or the manufacturer for further instructions.
5. **WARNING:** Maintain a separation distance from the antenna to person(s) of at least 20 cm.

You, as the qualified end-user of this radio device must control the exposure conditions of bystanders to ensure that the minimum separation distance (above) is maintained between the antenna and nearby persons for satisfying RF Exposure compliance.

The operation of this transmitter must satisfy the requirements of the Occupational/Controlled Exposure Environment for work-related use. Transmit only when person(s) are at least the minimum distance from the properly installed, externally mounted antenna.

## Europe

Versions of the BTR-800, TR-800, and TR-825 which display the “CE” symbol on the unit are compliant to the 2014/53/EU RED directive. These units conform to European Union directives, eligible to bear CE marking.

The full EC Declaration of Conformity for the BTR-800, TR-800, and TR-825 products may be found at the following website:

[www.rtsintercoms.com](http://www.rtsintercoms.com)

The equipment is in compliance with the following directives;

2015/863	RoHS Directive
2012/19/EU	WEEE Directive
2014/53/EU	RED Directive



Please dispose of the base station and backpacks at the end of its operation life by taking it to your closest collection point or recycling center.

This equipment is intended for use in professional audio intercom applications.

Some countries in the EEA (European Economic Area) have restrictions placed on this equipment. Listed below are these restrictions:

The equipment requires a license in the following countries (ISO 3166-1 two letter country code):

AT, BE, BG, HR, EE, FI, DE, GR, IS, IE, IT, LV, LI, LT, LU, MT, PL, PT, SK, SE, CH, GB.

The BTR-800 must be set to meet the 50 mW ERP maximum output power in the following countries (ISO 3166-1 two letter country code): AT, BE, BG, HR, EE, CY, DK, DE, FR, GR, HU, IS, IE, IT, LV, LI, LT, LU, MT, NL, NO, PL, RO, SK, SE, SI, ES, CH, GB.

France (FR): The use of equipment requires a license if not a professional user.

Austria (AT), Belgium (BE), and Germany (DE): Equipment may only be used in the 470-703 MHz band.

Finland (FI) and Iceland (IS): Equipment may only be used in the 470-694 MHz band.

Netherlands (NL): Equipment may NOT be used in the 556-558 MHz band.

Norway (NO): Equipment may only be used in the 510-790-MHz band.

Always consult your national authority before placing equipment into operation as requirements and spectrum usage can change.

## Industry Canada

The RTS BTR-800, TR-800, TR-825 transmitter/receiver are certified to Industry Canada RSS-210 rules.

Licensing of Bosch equipment is the users responsibility and depends upon the user’s classification, user’s application and frequency selected. Bosch strongly urges the user to contact the appropriate telecommunications authority for any desired clarification.

Pour se conformer aux exigences FCC et Industrie Canada l'exposition aux RF sur une distance de separation d'au moins 20 cm (7,9 pouces) doit etre maintenue entre les antennes de la station de base BTR-800 et toutes les personnes.

---

**CAUTION:** Any changes or modifications made to the above equipment could void the user's authority to operate the equipment.

---

**ATTENTION:** Tout changement ou modification non expressement approuvee par la partie responsable de la conformite pourraient annuler l'autorite de l'utilisateur a utiliser cet equipement.

## Three Band Base Stations

---

### Identifying a Three Band Unit

Three band base stations normally have a 18 MHz wide receive range of 650-668 MHz. These three band base stations are designated by having a 3 in the second digit of the two digit band code that is on a label on the rear panel of the unit.

### Regulatory Changes and the Three Band

There are two channel map configurations in a three band base station. One for the US/Canada and one for the rest of the world. At one time (before October, 2018) there was only one channel map for a three band unit, but due to regulatory changes in the US/Canada an additional map was produced and installed in three band base stations. The result of the FCC incentive auction in regard to wireless intercom was the following:

- Only 10 MHz (653-663 MHz) may be used for wireless intercom in the range 616 MHz to 698 MHz.
- Three band beltpack transmit power must be reduced to 20 mW EIRP for US/Canadian units.

Since the three band units are made for worldwide customers the 18 MHz range is the default shipped, therefore a US/Canadian user must set a base station to the new US channel map in order for the base's channel map to match the US three band beltpack's channel map. The US three band beltpacks only have the new US channel map in them.

**NOTE:** Only US/Canadian users of a three band base station need to change the channel map of the base station to the US channel map!

### Changing Channel Maps

A three band base station may be changed from a normal channel map to a US channel map and back again with the press of a couple buttons. The current channel map setting is remembered by the unit even if power is removed.

1. At the base station's main operating screen, press and hold the [SET]+[UP] buttons until the switching band text is displayed.  
The three band map the unit is switch to is displayed.
2. Release the buttons when the switching three band text is displayed.

The unit reboots and displays one of the following channel map versions.

*x30001 = Normal three band channel map*

*x3U001= US three band channel map*

*(where x is the current transmit band of the base station.)*

---

**Bosch Security Systems, Inc.**

12000 Portland Avenue South

Burnsville, MN 55337 U.S.A.

[www.rtsintercoms.com](http://www.rtsintercoms.com)