



**GE HARRIS**  
*Railway Electronics*

Document No. 5001366

15 March 1999

---

**Exhibit G**  
**Intentional Radiator Test Report (LCM)**

Prepared By:  
**Rubicom Systems, Inc.**

# RUBICOM SYSTEMS, INC.



FCC TEST REPORT  
(INTENTIONAL RADIATOR)  
FOR THE  
GE HARRIS  
LEGATO LOCOMOTIVE COMMUNICATIONS MODULE  
(LCM)  
SPREAD SPECTRUM TRANSMITTER  
COPY 1



Rubicom Systems, Inc.  
284 West Drive, Suite B  
Melbourne, FL 32904

THIS REPORT SHALL NOT BE REPRODUCED  
EXCEPT IN FULL WITHOUT THE WRITTEN  
APPROVAL OF THE TESTING LABORATORY



JA-1625-1

**FCC TEST REPORT**  
**(INTENTIONAL RADIATOR)**  
**FOR THE**  
**GE HARRIS**  
**LEGATO LOCOMOTIVE COMMUNICATIONS MODULE**  
**(LCM)**  
**SPREAD SPECTRUM TRANSMITTER**  
**S/N: 0006**

Prepared by: Joseph G. Barbee 3/26/99  
Joseph G. Barbee

Tested by: Joseph G. Barbee 3/26/99  
Joseph G. Barbee

Performed by:  
RUBICOM SYSTEMS INC.  
284 West Drive, Suite B  
Melbourne, Florida 32904

Performed for:  
GE HARRIS  
RAILWAY ELECTRONICS, L.L.C.  
405 John Rodes Blvd.  
Melbourne, Florida 32934

Received: March 5, 1999

Completed: March 11, 1999

## TABLE OF CONTENTS

<u>Paragraph</u>	<u>Title</u>	<u>Page</u>
	<b>CERTIFICATION</b> .....	1
	<b>ABSTRACT</b> .....	2
<b>1.0</b>	<b>INTRODUCTION</b> .....	3
1.1	Purpose .....	3
1.2	Requirements .....	3
1.3	Description of Equipment .....	5
1.3.1	<u>LCM Description</u> .....	5
1.4	Summary of Results .....	5
<b>2.0</b>	<b>APPLICABLE DOCUMENTS</b> .....	9
<b>3.0</b>	<b>TEST SITE DESCRIPTION</b> .....	10
3.1	Environmental Conditions .....	10
<b>4.0</b>	<b>TEST INSTRUMENTATION</b> .....	11
<b>5.0</b>	<b>TEST SAMPLE SETUP AND CONFIGURATIONS</b> .....	12
<b>6.0</b>	<b>PROCEDURES AND RESULTS</b> .....	15
6.1	General .....	15
6.2	Power Line Conducted 15.207 .....	16
6.3	Radiated Emissions 15.209/15.205 .....	16
6.3.1	<u>Radiated Emissions (Pre-Scans)</u> .....	16
6.3.2	<u>Radiated Emissions 15.209/15.205</u> .....	23
6.4	Direct Sequence Spread Spectrum 15.247(2)(b)(c)(d)(e) .....	47
6.4.1	<u>6dB Bandwidth 15.247(2)</u> .....	47
6.4.2	<u>Peak Output Power 15.247(2)(b)</u> .....	51
6.4.3	<u>Out of Band Emission 15.247(2)(c)</u> .....	51
6.4.4	<u>Power Spectral Density 15.247(2)(d)</u> .....	55
<b>APPENDIX A</b>	<b>COMPLIANCE LETTER</b> .....	62

JA-1625-1

**CERTIFICATION**

Rubicom Systems, Inc. certifies the information obtained in this report was performed consistent with the requirements of ANSI C63.4-1992. The GE Harris Legato Locomotive Communications Module (LCM) complies with the requirements of CFR 47 Part 15 for Intentional Radiators as required in Paragraph 15.247(a)(2)(b)(1)(c) and (d).

This data was obtained while testing an LCM, serial number 0006 (with two antenna configurations), furnished by GE Harris. Any modifications to the unit as tested may invalidate the data and void this certification.

**ABSTRACT**

This report presents test results of the emanations found emitting from the GE Harris Legato Locomotive Communications Module, Direct Sequence Spread Spectrum Transmitter and the comparison of these emissions to the requirements of FCC, Title 47, Part 15, Subpart C for Intentional Radiators as required for direct sequence type spread spectrum system operating in the 2.4 to 2.4835GHz range.

This testing was performed on a 3 meter open field test site at Rubicom Systems, Inc. (RSI). The testing was performed for GE Harris under purchase order 32844. The results of this test effort demonstrate compliance of the GE Harris LCM Spread Spectrum Transmitter to FCC, Title 47, Part 15, Subpart C Intentional Radiators (Paragraph 247(2)). The unit under test was serial number 0006. There are two configurations of this system as described in Paragraph 1.3 of this document.

## 1.0 INTRODUCTION

### 1.1 Purpose

The purpose of this report is to show compliance of the GE Harris LCM RF unit and antennas to the requirements of Part 15 of the FCC Rules and Regulations (47CFR, Part 15.247, Subpart C) for Intentional radiators. The applicable paragraphs covered by this report are 15.247(2) (b), (c) and (d). NOTE: Subparagraph (e), processing gain was completed by GE Harris

### 1.2 Requirements

The test requirements for an Intentional Radiator are as follows:

#### RADIATED (15.205)

<u>Frequency (MHZ)</u>	<u>Field Strength (<math>\mu</math>V/m)</u>	<u>Measurement Distance (m)</u>
0.009-0.490	2400/F (KHz)	300
0.490-1.705	240000/F (KHz)	30
1.705-30.0	30	30
30-88	100	3
88-216	150	3
216-960	200	3
Above 960	500 Average 5000 Peak	3

#### CONDUCTED (15.207)

Not applicable due to battery operation.

**DIRECT SEQUENCE SPREAD SPECTRUM SYSTEM****15.247(2) Bandwidth**

Bandwidth must be greater than 500KHz.

**15.247(2)(b) Maximum Peak Power**

The maximum peak output power of the transmitter shall not exceed 1 watt.

**15.247(2)(c) Out of Band Emissions, Radiated & Conducted**

Power produced by Modulation Products of the Spreading Sequence, Information Sequence and the Carrier Frequency.

Levels in any 100KHz outside the frequency band shall be 20dB below that of any 100KHz band within the band that contains the highest level of the desired power or the requirements of 15.209, whichever results in lesser attenuation. All other emissions shall not exceed the limits of Section 15.209(a).

**15.247(d) Power Density**

Transmitted power density averaged over any one (1) second interval shall not be greater than 8dBm in any 3KHz bandwidth.

**15.247(e) Processing Gain**

The processing gain shall be at least 10dB. The processing gain shall be determined from the ratio in dB of the signal to noise ratio with the system spreading code turned off to the signal to noise ratio with the system spreading code turned on, as measured at the demodulated output of the receiver.

Note: The results of testing the processing gain is not provided in this document.



### 1.3 Description of Equipment

The Legato system provides a wireless means to communicate between a locomotive and rail cars in order to control brake functions. The intentional transmitters are built from a radio module called the IntraTrain Communications Unit (ITCU). This ITCU is contained within both the CCU and LCM.

#### 1.3.1 LCM Description

The Locomotive Communication Module (LCM) is mounted in the cab of the locomotive. The LCM consists of an ITCU and a VIM card identical to the configuration used in the CCU, plus a power converter (locomotive 74 volts DC to 13.8 volts), a personality module (memory device), PRC card (locomotive electrical interface) and a locomotive control relay. The LCM is tested in conjunction with the antennas and cables supplied with the unit.

The LCM 2 configuration is presented in Figure 1.3.1-1. The LCM 4 configuration is presented in Figure 1.3.1-2. Note: The LCM 2 was tested as the worse case configuration with the shorter cables to the antenna. Transmitter harmonics were tested in the LCM 4 configuration to verify the additional antennas

### 1.4 Summary of Results

Paragraph 6.0 of this document presents the detailed results of each required test for the LCM. Each paragraph lists the signals determined to be emanating from the LCM.

Adjustment of the output power was required to obtain compliance.

**JA-1625-1**

**Specifically the input to the amplifier was at -10dB.**

**The data shows compliance to the requirements stated in paragraph 1.2 of this document.**

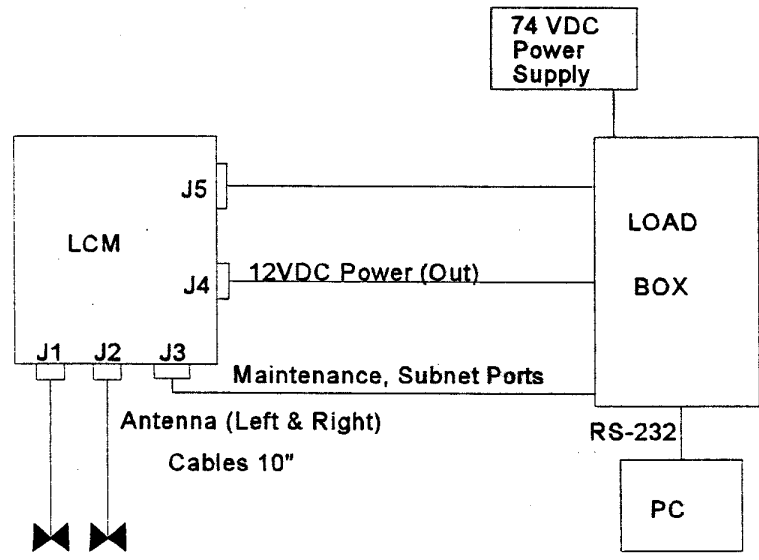

Figure 1.3.1-1

LCM 2-ANTENNA TEST SETUP



**2.0 APPLICABLE DOCUMENTS**

The following documents form a part of this report to the extent expressed herein:

FCC Code of Federal Regulations Title 47, Part 15

FCC Procedure for Measuring RF Emissions from Computing Devices  
FCC/OET MP-4, July 1987

ANSI C63.4-1992

FCC Characteristics of Open Field Test Sites Bulletin OET 55, October  
1989

JA-1625-1

### 3.0 TEST SITE DESCRIPTION

This testing was performed at Rubicom Systems, Inc. 3 meter test site. The description of the measurement facility was found to be compliant with the requirements of Section 2.948 of the FCC Rules. A copy of the compliance letter is attached to this report as Appendix A.

#### 3.1 Environmental Conditions

This test effort was performed from 05 March, 1999 through 11 March, 1999.

Typical conditions for the test site during this testing was:

Temperature:	<b>70° - 85° F</b>
Barometer:	<b>29.75 inches</b>
Humidity:	<b>50 - 80%</b>

JA-1625-1

#### 4.0 TEST INSTRUMENTATION

The following test equipment was used to perform this testing.

<u>Qty.</u>	<u>Description</u>	<u>Manufacturer</u>	<u>Model No.</u>	<u>Cal.Due</u>	<u>Cal Cycle</u>
1	Spectrum Analyzer	Advantest	R3271A	09/09/99	1 yr.
1	Spectrum Analyzer	Hewlett Packard	HP8566B	07/20/99	1 yr.
1	Spectrum Analyzer	Advantest	R3261A	07/22/99	1 yr.
2	Bi-Log antenna	Chase	CLB6111B	07/24/99	1 yr.
1	Plotter	Hewlett Packard	7440A	NCR	
1	Ridge Guide Horn Antenna	Electro Metrics	RGA-180 1-18GHz	01/15/00	1 yr.
1	Power Meter (Peak)	Pacific Microwave	1018B	04/15/99	1 yr.
1	Standard Gain Horn Antenna	NARDA	638	NCR	
1	Band Rejection Filter (2.3G-2.5GHz)	Lorch Microwave	19428	03/27/99	1 yr.
1	High Pass Filter	Reactel Inc.	4HS-3G/ 12G-S11	01/20/01	2 yr.
1	Amplifier 1G-26.5GHz	Hewlett Packard	H8449B	01/25/01	2 yr.
2	Attenuators	Hewlett Packard	H8491C	02/02/00	1 yr.

## 5.0 TEST SAMPLE SETUP AND CONFIGURATIONS

The LCM was placed on a nonconductive table inside a shielded enclosure. A fully charged battery was used during all testing. During conducted measurements the output was coupled directly to the spectrum analyzer or power meter. Attenuators were inserted as required.

During radiated emissions the LCM was placed on the turn table. The test software was used during all measurements. Above 18GHz the radiated measurements were performed in a semi-anechoic chamber.

Photo 1 presents the LCM2 placed on the turntable during radiated testing (LCM2 #4). Photo 2 presents the LCM 4 placed on the turntable (LCM4 #4).



JA-1625-1

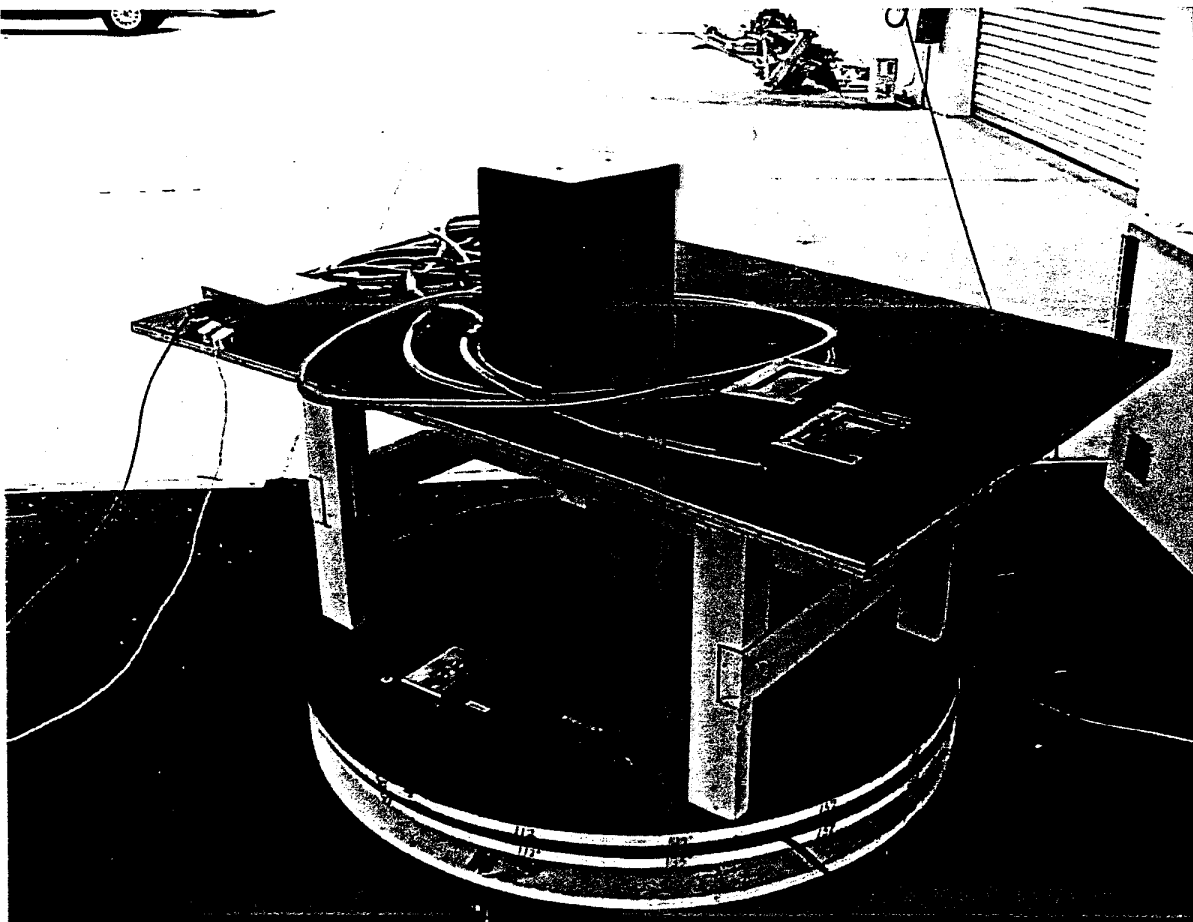

PHOTO #1

JA-1625-1

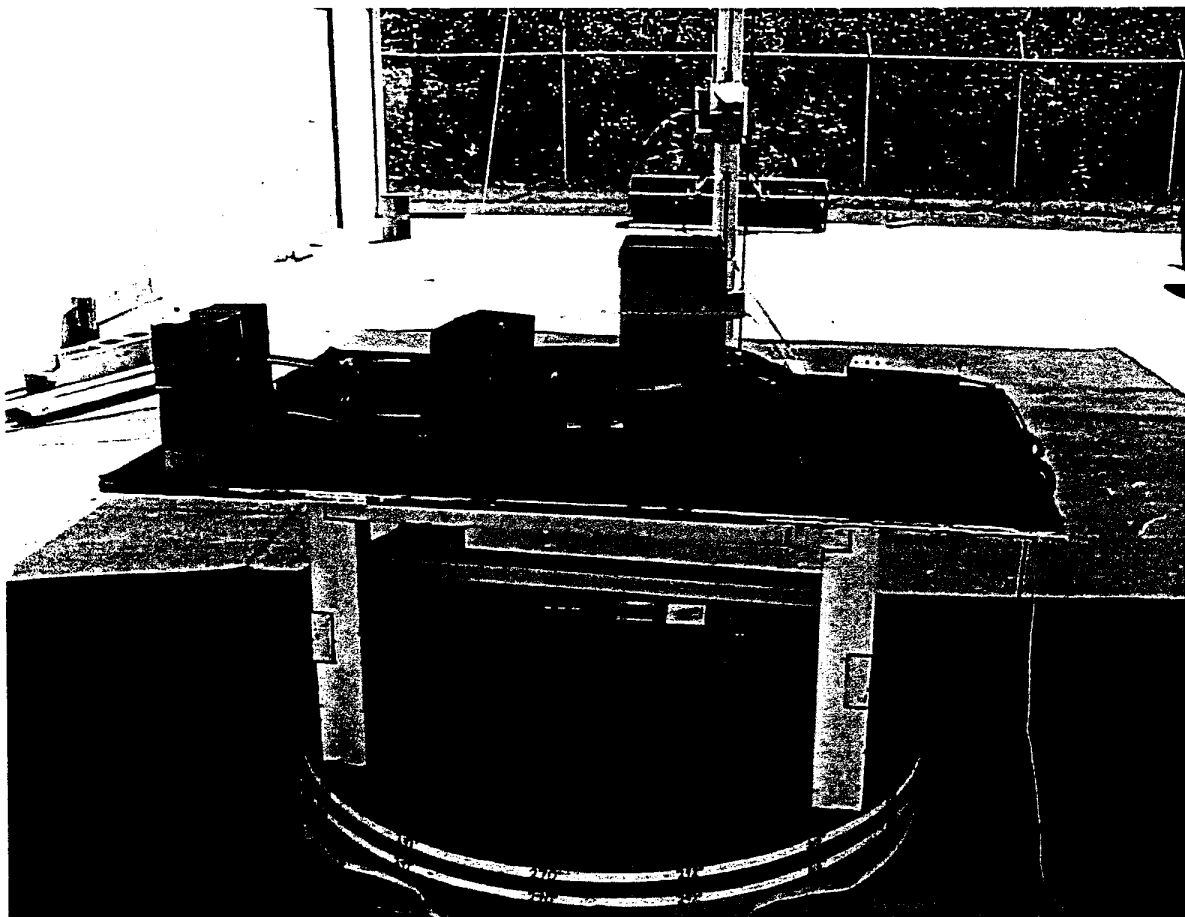

PHOTO 2

## 6.0 PROCEDURES AND RESULTS

### 6.1 General

The data presented in this report is provided using the Advantest Spectrum Analyzers. The analyzer allows the antenna factors/cable loss, etc., to be listed in tables on a memory card. Test setups for recall are programmed. This method allows the tester to plot data instantaneously against the specification requirement. The specification limits are presented with the extrapolation for distance (20dB/decade) where necessary. When external attenuation is required for analyzer protection, the reference level offset is used.

Signal identification is partially accomplished by turning the system power "on" and "off" while observing the spectrum. All signals found to be emitting from the EUT are maximized in azimuth and elevation. Should the need arise to have more than a single plot of the frequency range the maximized signal would be linked to the proper plot.

The displayed levels are calculated in the analyzer as follows: MTR Reading + Antenna Factor + Cable Loss - Gain (where appropriate) = Signal level.

NOTE: The correction factors and conversion factors are combined in the memory card.

A band reject filter (2.314-2.534GHz) was used for sweeps made above 1GHz, except when testing around the transmitter.

JA-1625-1

**6.2 Power Line Conducted 15.207**

The unit is operated from battery only, therefore, no power line conduction is required.

**6.3 Radiated Emissions 15.209/15.205****6.3.1 Radiated Emissions (Pre-Scans)**

Radiated emission pre-testing was performed on the system inside the shielded enclosure. Pre-scans were performed over the frequency range of 30MHz-1GHz. These scans are for frequency content in the high ambient range. This test is performed at 1 meter. No significant signals were detected during this evaluation. Reference Data Sheets 6.3.1-1 through 6.3.1-6.