

APPLICATION CERTIFICATION FCC Part 15C
On Behalf of
Guangdong Mixwell Technology Co., Ltd.

SMART WI-FI HUMIDIFIER

Model No.: MW3038, TH35S

FCC ID: 2AT8F-MW3038

Prepared for : Guangdong Mixwell Technology Co., Ltd.
Address : 1-4#F, A building, No.7, Yu Hua Street, 138 Industrial
Area, TangXia, DongGuan, China.

Prepared by : Shenzhen Accurate Technology Co., Ltd.
Address : 1/F., Building A, Changyuan New Material Port,
Science & Industry Park, Nanshan District,
Shenzhen, Guangdong, P.R. China

Tel: (0755) 26503290
Fax: (0755) 26503396

Report No. : ATE20191168
Date of Test : Aug. 03, 2019--Aug. 12, 2019
Date of Report : Aug. 13, 2019

TABLE OF CONTENTS

Description	Page
Test Report Certification	
1. GENERAL INFORMATION	5
1.1. Description of Device (EUT).....	5
1.2. Special Accessory and Auxiliary Equipment	5
1.3. Model difference declaration	5
1.4. Laboratory Accreditation and Relationship to Customer	6
1.5. Measurement Uncertainty.....	6
2. MEASURING DEVICE AND TEST EQUIPMENT	7
2.1. For Radiated Emission Measurement	7
2.2. The Equipment Used to Measure Conducted Disturbance (L.I.S.N).....	8
3. OPERATION OF EUT DURING TESTING	9
3.1. Operating Mode	9
3.2. Carrier Frequency of Channels	9
3.3. Configuration and peripherals	9
3.4. Test mode.....	10
4. TEST PROCEDURES AND RESULTS	11
5. 6DB OCCUPIED BANDWIDTH TEST	12
5.1. Block Diagram of Test Setup.....	12
5.2. The Requirement For Section 15.247(a)(1).....	12
5.3. EUT Configuration on Measurement	12
5.4. Operating Condition of EUT	12
5.5. Test Procedure	12
5.6. Test Result	13
6. 99% OCCUPIED BANDWIDTH	19
6.1. Block Diagram of Test Setup.....	19
6.2. EUT Configuration on Measurement	19
6.3. Operating Condition of EUT	19
6.4. Test Procedure	19
6.5. Measurement Result	20
7. DUTY CYCLE MEASUREMENT.....	26
7.1. Block Diagram of Test Setup.....	26
7.2. EUT Configuration on Measurement	26
7.3. Operating Condition of EUT	26
7.4. Test Procedure	26
7.5. Test Result	27
8. POWER SPECTRAL DENSITY TEST.....	30
8.1. Block Diagram of Test Setup.....	30
8.2. The Requirement For Section 15.247(e).....	30
8.3. EUT Configuration on Measurement	30
8.4. Operating Condition of EUT	30
8.5. Test Procedure	30
8.6. Test Result	31
9. MAXIMUM CONDUCTED (AVERAGE) OUTPUT POWER	37
9.1. Block Diagram of Test Setup.....	37
9.2. The Requirement For Section 15.247(b)(3).....	37

9.3.	EUT Configuration on Measurement	37
9.4.	Operating Condition of EUT	37
9.5.	Test Procedure	37
9.6.	Test Result	38
10.	RADIATED SPURIOUS EMISSION TEST	44
10.1.	Block Diagram of Test Setup.....	44
10.2.	The Limit For Section 15.247(d)	46
10.3.	Restricted bands of operation	46
10.4.	Configuration of EUT on Measurement	47
10.5.	Operating Condition of EUT	47
10.6.	Test Procedure	47
10.7.	The Field Strength of Radiation Emission Measurement Results	48
11.	BAND EDGE COMPLIANCE TEST	61
11.1.	Block Diagram of Test Setup.....	61
11.2.	The Requirement For Section 15.247(d)	61
11.3.	EUT Configuration on Measurement	61
11.4.	Operating Condition of EUT	61
11.5.	Test Procedure	62
11.6.	Test Result	62
12.	POWER LINE CONDUCTED MEASUREMENT	79
12.1.	Block Diagram of Test Setup.....	79
12.2.	Power Line Conducted Emission Measurement Limits.....	79
12.3.	Configuration of EUT on Measurement	79
12.4.	Operating Condition of EUT	79
12.5.	Test Procedure	80
12.6.	DATA SAMPLE	80
12.7.	Power Line Conducted Emission Measurement Results	81
13.	ANTENNA REQUIREMENT.....	84
13.1.	The Requirement	84
13.2.	Antenna Construction	84

Test Report Certification

Applicant : Guangdong Mixwell Technology Co., Ltd.
Address : 1-4#F, A building, No.7, Yu Hua Street,138 Industrial Area,
TangXia, DongGuan, China.
Manufacturer : Guangdong Mixwell Technology Co., Ltd.
Address : 1-4#F, A building, No.7, Yu Hua Street,138 Industrial Area,
TangXia, DongGuan, China.
Product : SMART WI-FI HUMIDIFIER
Model No. : MW3038, TH35S
Trade name : **Tendomi**

Measurement Procedure Used:

**FCC Rules and Regulations Part 15 Subpart C Section 15.247
ANSI C63.10: 2013**

The EUT was tested according to DTS test procedure of April 02, 2019 KDB558074 D01 DTS Meas Guidance v0502 for compliance to FCC 47CFR 15.247 requirements.

The device described above is tested by SHENZHEN ACCURATE TECHNOLOGY CO. LTD to determine the maximum emission levels emanating from the device. The maximum emission levels are compared to the FCC Part 15 Subpart C Section 15.247 limits. The measurement results are contained in this test report and SHENZHEN ACCURATE TECHNOLOGY CO. LTD is assumed full responsibility for the accuracy and completeness of these measurements. Also, this report shows that the Equipment Under Test (EUT) is to be technically compliant with the FCC requirements.

This report applies to above tested sample only. This report shall not be reproduced in part without written approval of SHENZHEN ACCURATE TECHNOLOGY CO. LTD.

Date of Test : Aug. 03, 2019--Aug. 12, 2019

Date of Report : Aug. 13, 2019

Prepared by : _____

Tim Zhang
(Tim Zhang, Engineer)

Approved & Authorized Signer : _____

Sean Liu
(Sean Liu, Manager)

1. GENERAL INFORMATION

1.1. Description of Device (EUT)

EUT	:	SMART WI-FI HUMIDIFIER
Model Number	:	MW3038, TH35S
Frequency Range	:	802.11b/g/n(20MHz): 2412-2462MHz
Number of Channels	:	802.11b/g/n (20MHz):11
G _{ANT} MAX	:	2.51dBi
Type of Antenna	:	PCB Antenna
Power Supply	:	AC 100-240V~, 50/60Hz
Data Rate	:	802.11b: 11, 5.5, 2, 1 Mbps 802.11g: 54, 48, 36, 24, 18, 12, 9, 6 Mbps 802.11n: up to 150Mbps
Modulation Type	:	DSSS, OFDM
Applicant	:	Guangdong Mixwell Technology Co., Ltd.
Address	:	1-4#F, A building, No.7, Yu Hua Street,138 Industrial Area, TangXia, DongGuan, China
Manufacturer	:	Guangdong Mixwell Technology Co., Ltd.
Address	:	1-4#F, A building, No.7, Yu Hua Street,138 Industrial Area, TangXia, DongGuan, China
Date of sample received	:	Aug. 02, 2019
Date of Test	:	Aug. 03, 2019--Aug. 12, 2019

1.2. Special Accessory and Auxiliary Equipment

PC	Manufacturer: LENOVO
	M/N: 4290-RT8
	S/N: R9-FW93G 11/08

1.3. Model difference declaration

MW3038, TH35S are identical in interior structure, electrical circuits and components, and just model number is different for the marketing requirement.

1.4.Laboratory Accreditation and Relationship to Customer

EMC Lab : Recognition of accreditation by Federal Communications Commission (FCC)
The Designation Number is CN1189
The Registration Number is 708358

Listed by Innovation, Science and Economic Development Canada (ISED)
The Registration Number is 5077A-2

Accredited by China National Accreditation Service for Conformity Assessment (CNAS)
The Registration Number is CNAS L3193

Accredited by American Association for Laboratory Accreditation (A2LA)
The Certificate Number is 4297.01

Name of Firm : Shenzhen Accurate Technology Co., Ltd.
Site Location : 1/F., Building A, Changyuan New Material Port, Science & Industry Park, Nanshan District, Shenzhen, Guangdong, P.R. China

1.5.Measurement Uncertainty

Conducted Emission Expanded Uncertainty = 2.72dB, k=2
(Mains ports, 9kHz-30MHz)

Radiated emission expanded uncertainty = 2.66dB, k=2
(9kHz-30MHz)

Radiated emission expanded uncertainty = 4.28dB, k=2
(30MHz-1000MHz)

Radiated emission expanded uncertainty = 4.98dB, k=2
(1G-18GHz)

Radiated emission expanded uncertainty = 5.06dB, k=2
(18G-26.5GHz)

2. MEASURING DEVICE AND TEST EQUIPMENT

2.1.For Radiated Emission Measurement

Item	Equipment	Manufacturer	Model No.	Serial No.	Last Cal.	Cal. Interval
1.	Spectrum Analyzer	Agilent	E7405A	MY45115511	Jan.05, 2019	1 Year
2.	Spectrum Analyzer	Rohde&Schwarz	FSV40	101495	Jan.05, 2019	1 Year
3.	Test Receiver	Rohde&Schwarz	ESCS30	100307	Jan.05, 2019	1 Year
4.	Test Receiver	Rohde& Schwarz	ESPI	100396/003	Jan.05, 2019	1 Year
5.	Test Receiver	Rohde& Schwarz	ESPI	101526/003	Jan.05, 2019	1 Year
6.	Test Receiver	Rohde& Schwarz	ESR	101817	Jan.05, 2019	1 Year
7.	Bilog Antenna	Schwarzbeck	VULB9163	9163-194	Jan.05, 2019	1 Year
8.	Bilog Antenna	Schwarzbeck	VULB9163	9163-323	Jan.05, 2019	1 Year
9.	Log.-Per.Antenna	Schwarzbeck	VUSLP 9111B	9111B-074	Jan.05, 2019	1 Year
10.	Biconical Broad Band Antenna	Schwarzbeck	VHBB 9124+BBA 9106	9124-617	Jan.05, 2019	1 Year
11.	Loop Antenna	Schwarzbeck	FMZB1516	1516131	Jan.05, 2019	1 Year
12.	Horn Antenna	Schwarzbeck	BBHA9120D	9120D-655	Jan.05, 2019	1 Year
13.	Horn Antenna	Schwarzbeck	BBHA9120D	9120D-1067	Jan.05, 2019	1 Year
14.	Vertical Active Monopole Antenna	Schwarzbeck	VAMP 9243	9243-370	Jan.05, 2019	1 Year
15.	RF Switching Unit+PreAMP	Compliance Direction	RSU-M2	38322	Jan.05, 2019	1 Year
16.	Pre-Amplifier	Agilent	8447D	294A10619	Jan.05, 2019	1 Year
17.	Pre-Amplifier	Rohde&Schwarz	CBLU11835 40-01	3791	Jan.05, 2019	1 Year
18.	50 Coaxial Switch	Anritsu Corp	MP59B	6200237248	Jan.05, 2019	1 Year
19.	50 Coaxial Switch	Anritsu Corp	MP59B	6200506474	Jan.05, 2019	1 Year
20.	RF Coaxial Cable	Schwarzbeck	N-5m	No.1	Jan.05, 2019	1 Year
21.	RF Coaxial Cable	Schwarzbeck	N-1m	No.6	Jan.05, 2019	1 Year
22.	RF Coaxial Cable	Schwarzbeck	N-1m	No.7	Jan.05, 2019	1 Year
23.	RF Coaxial Cable	SUHNER	N-3m	No.8	Jan.05, 2019	1 Year
24.	RF Coaxial Cable	RESENBERGER	N-3.5m	No.9	Jan.05, 2019	1 Year
25.	RF Coaxial Cable	SUHNER	N-6m	No.10	Jan.05, 2019	1 Year
26.	RF Coaxial Cable	RESENBERGER	N-12m	No.11	Jan.05, 2019	1 Year
27.	RF Coaxial Cable	RESENBERGER	N-0.5m	No.12	Jan.05, 2019	1 Year
28.	RF Coaxial Cable	SUHNER	N-2m	No.13	Jan.05, 2019	1 Year
29.	RF Coaxial Cable	SUHNER	N-0.5m	No.15	Jan.05, 2019	1 Year
30.	RF Coaxial Cable	SUHNER	N-2m	No.16	Jan.05, 2019	1 Year
31.	RF Coaxial Cable	RESENBERGER	N-6m	No.17	Jan.05, 2019	1 Year
Radiated Emission Measurement Software: EZ EMC V1.1.4.2						

2.2.The Equipment Used to Measure Conducted Disturbance (L.I.S.N)

Item	Equipment	Manufacturer	Model No.	Serial No.	Last Cal.	Cal. Interval
1.	Test Receiver	Rohde & Schwarz	ESCS30	100307	Jan.05, 2019	1 Year
2.	Test Receiver	Rohde & Schwarz	ESPI3	100396/003	Jan.05, 2019	1 Year
3.	Test Receiver	Rohde & Schwarz	ESPI3	101526/003	Jan.05, 2019	1 Year
4.	L.I.S.N.	Schwarzbeck	NLSK8126	8126431	Jan.05, 2019	1 Year
5.	L.I.S.N.	Rohde & Schwarz	ESH3-Z5	100305	Jan.05, 2019	1 Year
6.	L.I.S.N.	Rohde & Schwarz	ESH3-Z5	100310	Jan.05, 2019	1 Year
7.	L.I.S.N.	Rohde & Schwarz	ESH3-Z6	100132	Jan.05, 2019	1 Year
8.	Pulse Limiter	Rohde & Schwarz	ESH3-Z2	100305	Jan.05, 2019	1 Year
9.	Pulse Limiter	Rohde & Schwarz	ESH3-Z2	100312	Jan.05, 2019	1 Year
10.	Pulse Limiter	Rohde & Schwarz	ESH3-Z2	100815	Jan.05, 2019	1 Year
11.	50Ω Coaxial Switch	Anritsu Corp	MP59B	6200283936	Jan.05, 2019	1 Year
12.	50Ω Coaxial Switch	Anritsu Corp	MP59B	6200283933	Jan.05, 2019	1 Year
13.	50Ω Coaxial Switch	Anritsu Corp	MP59B	6200506474	Jan.05, 2019	1 Year
14.	VOLTAGE PROBE	Schwarzbeck	TK9416	N/A	Jan.05, 2019	1 Year
15.	RF CURRENT PROBE	Rohde & Schwarz	EZ-17	100048	Jan.05, 2019	1 Year
16.	8-Wire Impedance Stabilisation Network	Schwarzbeck	CAT5 8158	8158-0035	Jan.05, 2019	1 Year
17.	RF Coaxial Cable	SUHNER	N-2m	No.2	Jan.05, 2019	1 Year
18.	RF Coaxial Cable	SUHNER	N-2m	No.3	Jan.05, 2019	1 Year
19.	RF Coaxial Cable	SUHNER	N-2m	No.14	Jan.05, 2019	1 Year
Conducted Emission Measurement Software: ES-K1 V1.71						

3. OPERATION OF EUT DURING TESTING

3.1.Operating Mode

The mode is used: **1.802.11b Transmitting mode**

Low Channel: 2412MHz

Middle Channel: 2437MHz

High Channel: 2462MHz

2.802.11g Transmitting mode

Low Channel: 2412MHz

Middle Channel: 2437MHz

High Channel: 2462MHz

3.802.11n (20MHz) Transmitting mode

Low Channel: 2412MHz

Middle Channel: 2437MHz

High Channel: 2462MHz

3.2.Carrier Frequency of Channels

802.11b, 802.11g, 802.11n (20MHz)

Channel	Frequency(MHz)	Channel	Frequency(MHz)
01	2412	07	2442
02	2417	08	2447
03	2422	09	2452
04	2427	10	2457
05	2432	11	2462
06	2437	---	---

3.3.Configuration and peripherals

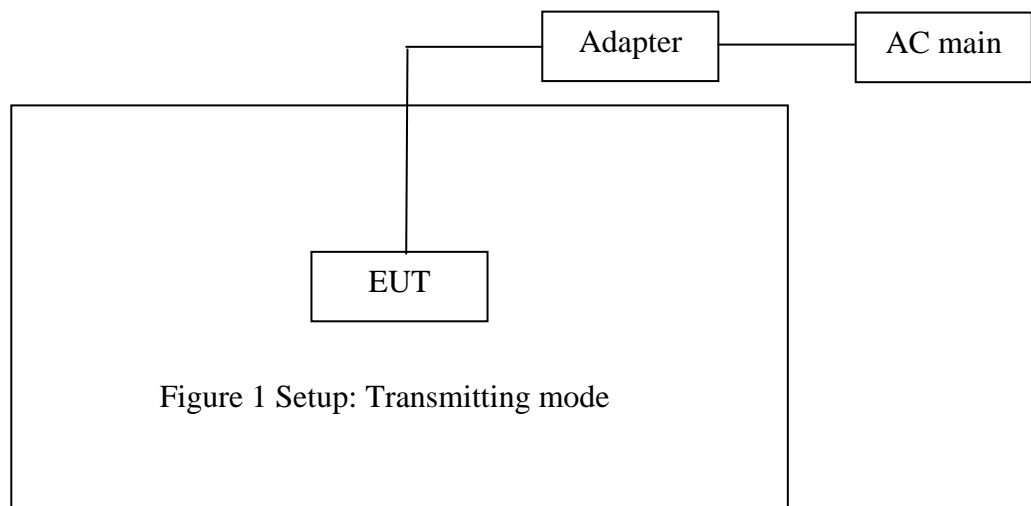

3.4. Test mode

Test Mode	Test Modes Description
11B	IEEE 802.11b with data rate of 1 Mbps
11G	IEEE 802.11g with data rate of 6 Mbps
11N20MHz	IEEE 802.11n with data rate of MCS0 and bandwidth of 20 MHz

NOTE: Worst cases for each IEEE 802.11 mode are selected to perform tests.

4. TEST PROCEDURES AND RESULTS

FCC Rules	Description of Test	Result
Section 15.207	AC power Line Conducted Emission Test	Compliant
Section 15.247(a)(2)	6dB Occupied Bandwidth Test	Compliant
KDB558074 D01 DTS Meas Guidance v0502	Duty cycle	Compliant
KDB558074 D01 DTS Meas Guidance v0502	OBW	Compliant
Section 15.247(b)(3)	Maximum conducted (average) output power	Compliant
Section 15.247(e)	Power Spectral Density Test	Compliant
Section 15.205 Section 15.209	Radiated Spurious Emissions Test	Compliant
Section 15.247(d)	Band Edge Compliance Test	Compliant
Section 15.203	Antenna Requirement	Compliant

5. 6DB OCCUPIED BANDWIDTH TEST

5.1. Block Diagram of Test Setup

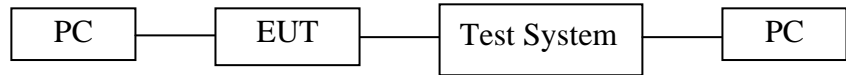

5.2. The Requirement For Section 15.247(a)(1)

Section 15.247(a)(2): Systems using digital modulation techniques may operate in the 902–928 MHz, 2400–2483.5 MHz, and 5725–5850 MHz bands. The minimum 6 dB band-width shall be at least 500 kHz

5.3. EUT Configuration on Measurement

The equipment are installed on the emission measurement to meet the commission requirements and operating regulations in a manner which tends to maximize its emission characteristics in normal application.

5.4. Operating Condition of EUT

5.4.1. Setup the EUT and simulator as shown as Section 5.1.

5.4.2. Turn on the power of all equipment.

5.4.3. Let the EUT work in TX modes measure it. The transmit frequency are 2412-2462MHz. We select 2412MHz, 2437MHz and 2462MHz TX frequency to transmit.

5.5. Test Procedure

5.5.1. The transmitter output was connected to the spectrum analyzer through a low loss cable.

5.5.2. Set RBW of spectrum analyzer to 100 kHz and VBW to 300 kHz.

5.5.3. The 6dB bandwidth is defined as the total spectrum the power of which is higher than peak power minus 6dB.

5.6. Test Result

The test was performed with 802.11b			
Channel	Frequency (MHz)	6dB Bandwidth (MHz)	Limit (MHz)
Low	2412	10.00	> 0.5MHz
Middle	2437	9.08	> 0.5MHz
High	2462	9.12	> 0.5MHz

The test was performed with 802.11g			
Channel	Frequency (MHz)	6dB Bandwidth (MHz)	Limit (MHz)
Low	2412	15.84	> 0.5MHz
Middle	2437	15.80	> 0.5MHz
High	2462	15.68	> 0.5MHz

The test was performed with 802.11n (Bandwidth: 20 MHz)			
Channel	Frequency (MHz)	6dB Bandwidth (MHz)	Limit (MHz)
Low	2412	16.32	> 0.5MHz
Middle	2437	15.68	> 0.5MHz
High	2462	16.04	> 0.5MHz

The spectrum analyzer plots are attached as below.

6dB Bandwidth 802.11b Channel Low 2412MHz

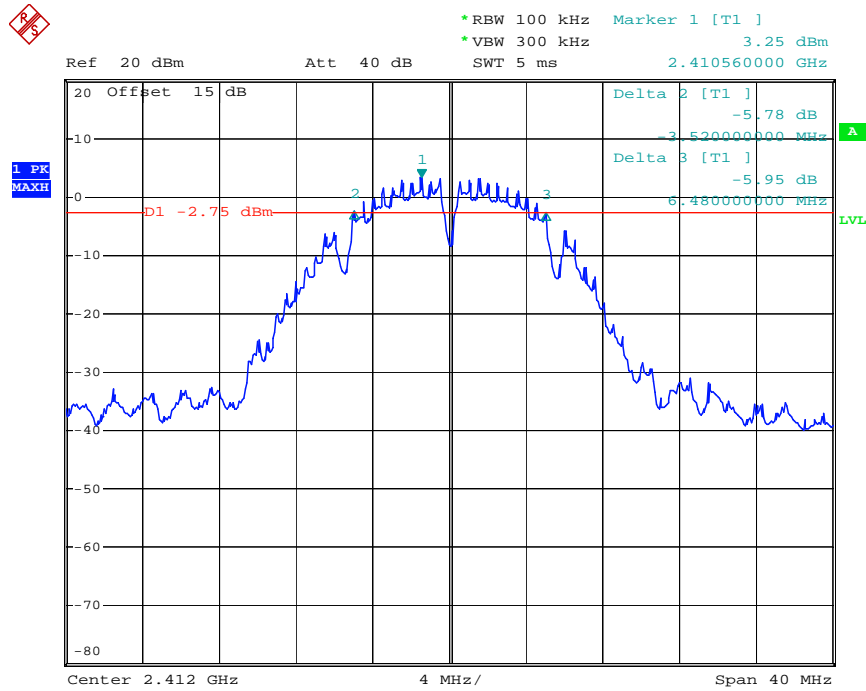

Date: 6.AUG.2019 13:13:46

802.11b Channel Middle 2437MHz

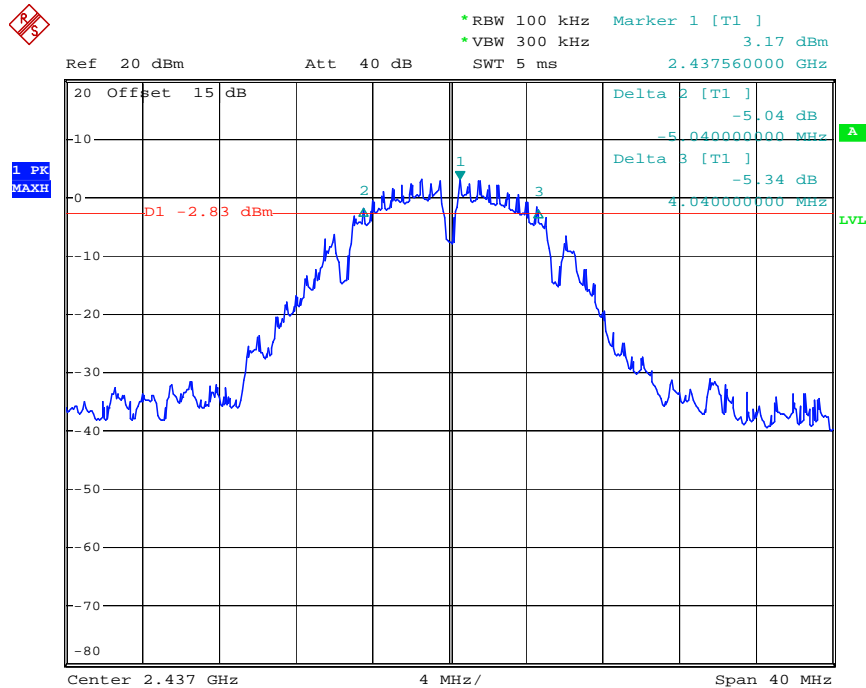

Date: 6.AUG.2019 13:17:07

802.11b Channel High 2462MHz

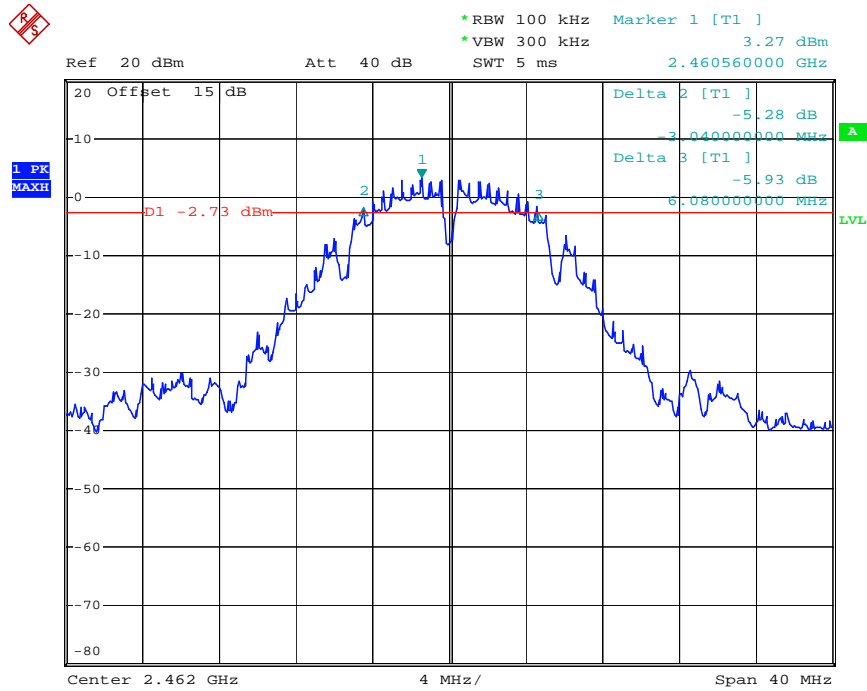

Date: 6.AUG.2019 13:18:04

802.11g Channel Low 2412MHz

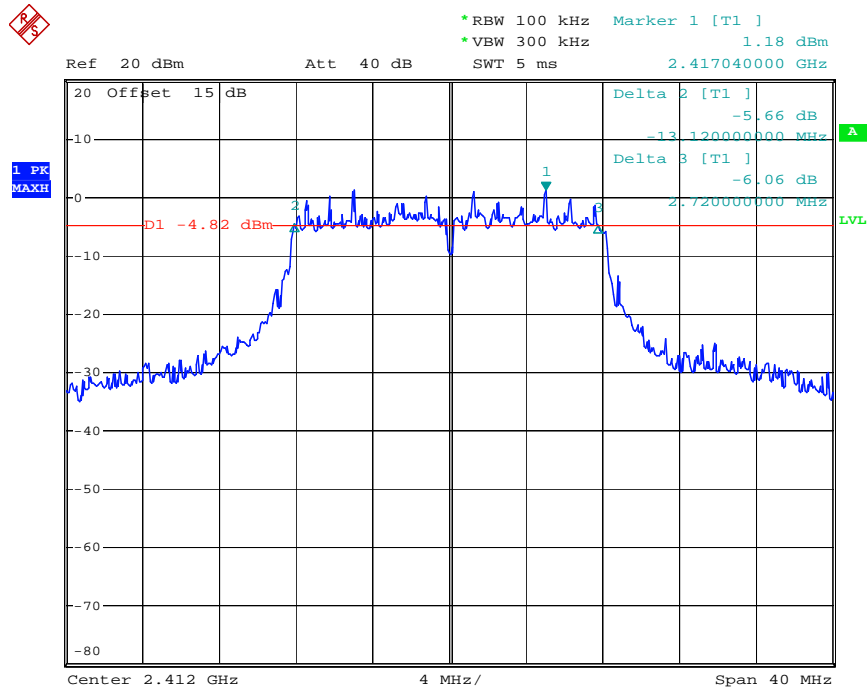

Date: 6.AUG.2019 13:22:49

802.11g Channel Middle 2437MHz

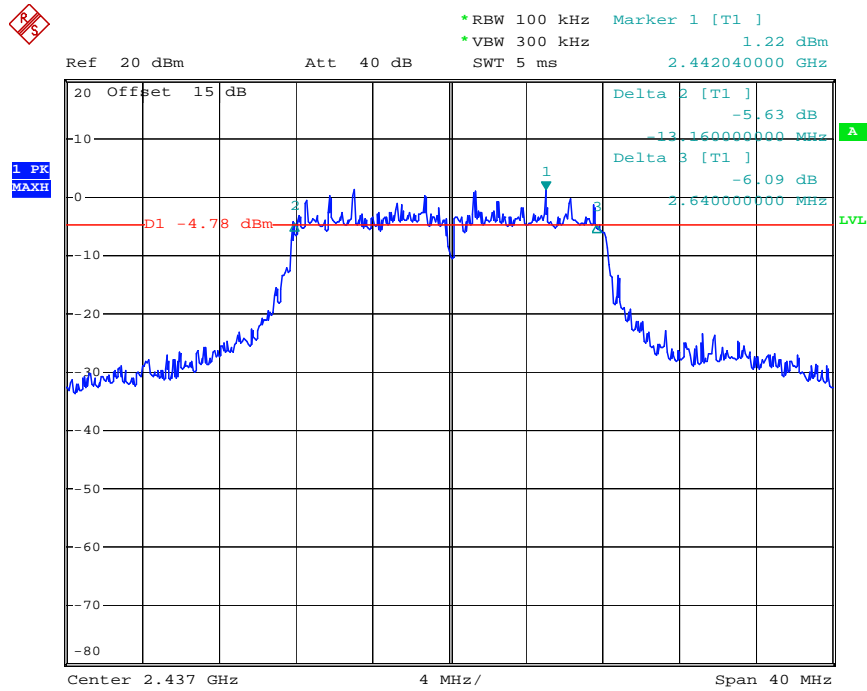

Date: 6.AUG.2019 13:21:45

802.11g Channel High 2462MHz

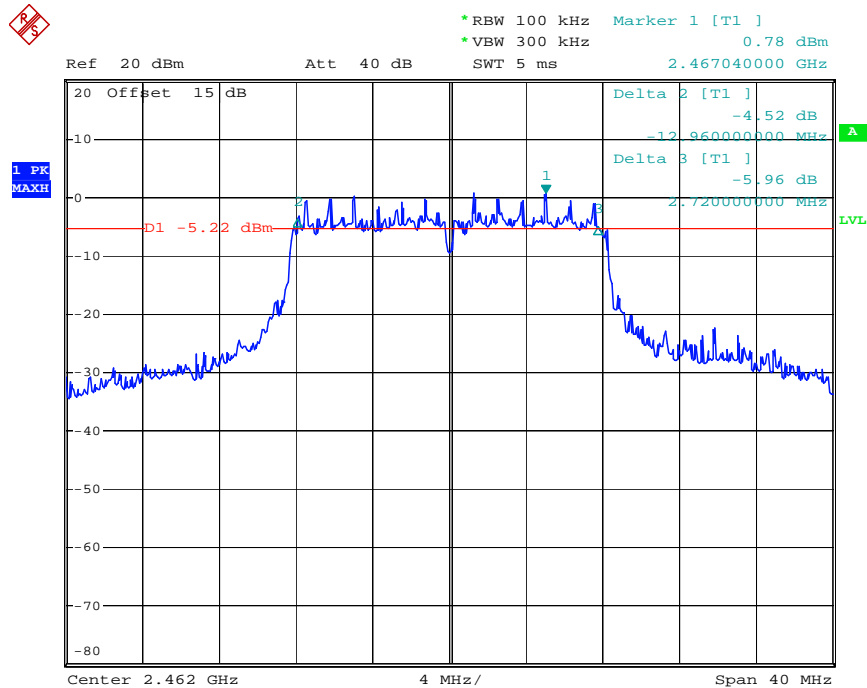

Date: 6.AUG.2019 13:20:11

802.11n Channel Low 2412MHz (20MHz)

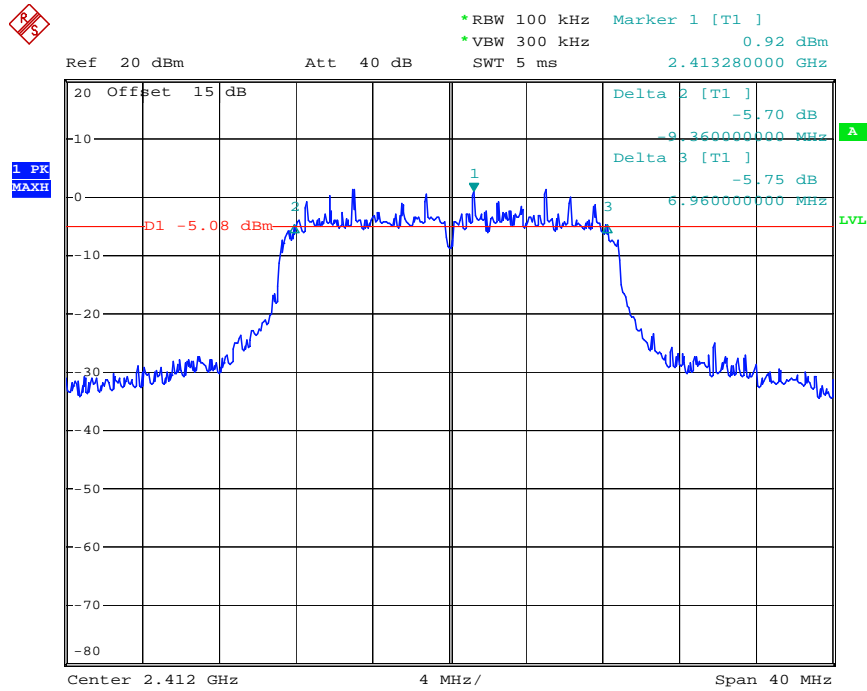

Date: 6.AUG.2019 13:23:43

802.11n Channel Middle 2437MHz(20MHz)

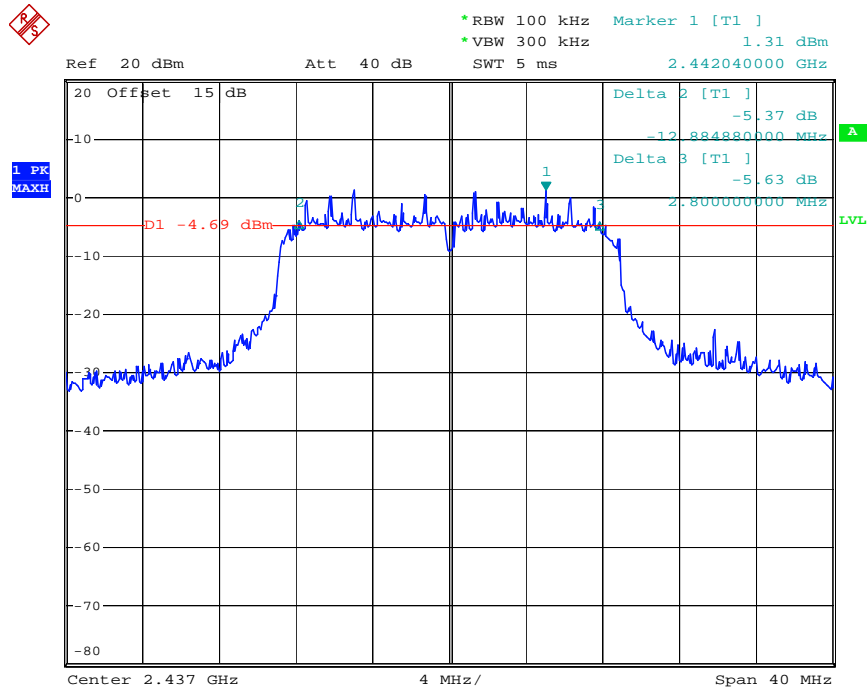

Date: 6.AUG.2019 13:24:46

802.11n Channel High 2462MHz(20MHz)

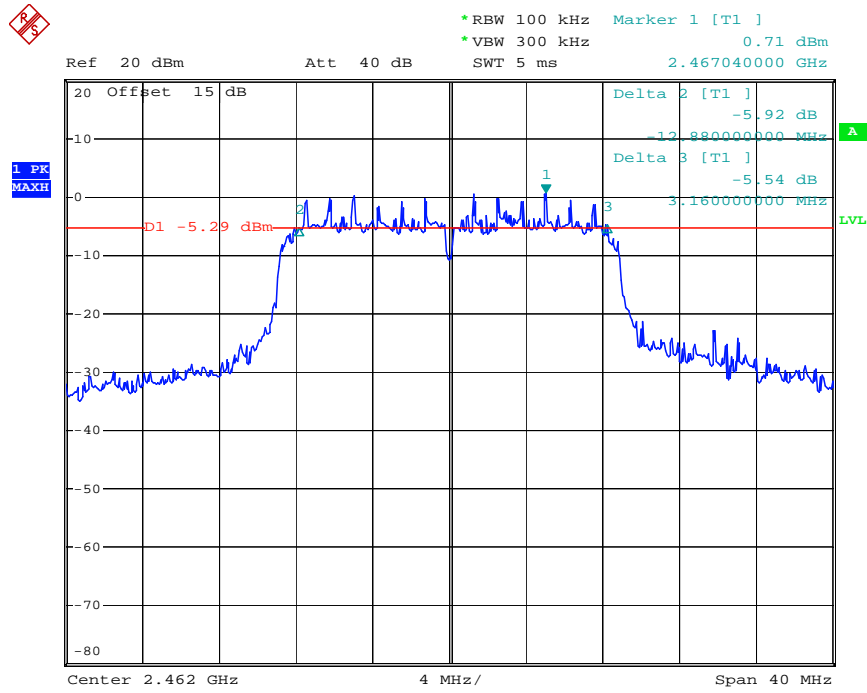

Date: 6.AUG.2019 13:25:37

6. 99% OCCUPIED BANDWIDTH

6.1. Block Diagram of Test Setup

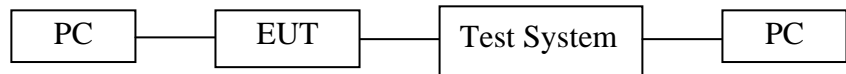

6.2. EUT Configuration on Measurement

The following equipment is installed on the emission measurement to meet the commission requirements and operating regulations in a manner which tends to maximize its emission characteristics in normal application.

6.3. Operating Condition of EUT

6.3.1. Setup the EUT and simulator as shown as Section 6.1.

6.3.2. Turn on the power of all equipment.

6.3.3. Let the EUT work in TX modes measure it. The transmit frequency are 2412-2462MHz. We select 2412MHz, 2437MHz and 2462MHz TX frequency to transmit.

6.4. Test Procedure

6.4.1. The transmitter output was connected to the spectrum analyzer through a low loss cable. The transmitter shall be operated at its maximum carrier power measured under normal test conditions. The span of the analyzer shall be set to capture all products of the modulation process, including the emission skirts.

6.4.2. The resolution bandwidth (RBW) shall be in the range of 1% to 5% of the occupied bandwidth (OBW) and video bandwidth (VBW) shall be approximately 3x RBW.

6.4.3. A peak, or peak hold, may be used in place of the sampling detector as this may produce a wider bandwidth than the actual bandwidth (worst-case measurement). Use of a peak hold may be necessary to determine the occupied bandwidth if the device is not transmitting continuously.

6.4.4. Set SPA "Meas" function, Select "Occupied Bandwidth" function, Select "99% Power Bandwidth". The frequency of the upper and lower markers indicating the edges of the transmitters "99% Power" emission bandwidth shall be recorded to automate by SPA.

6.5.Measurement Result

The test was performed with 802.11b		
Channel	Frequency (MHz)	99% Occupied Bandwidth (MHz)
Low	2412	13.92
Middle	2437	13.68
High	2462	13.76

The test was performed with 802.11g		
Channel	Frequency (MHz)	99% Occupied Bandwidth (MHz)
Low	2412	17.20
Middle	2437	17.36
High	2462	17.20

The test was performed with 802.11n (Bandwidth: 20 MHz)		
Channel	Frequency (MHz)	99% Occupied Bandwidth (MHz)
Low	2412	18.00
Middle	2437	18.08
High	2462	18.08

The spectrum analyzer plots are attached as below.

802.11b Low Channel 2412MHz

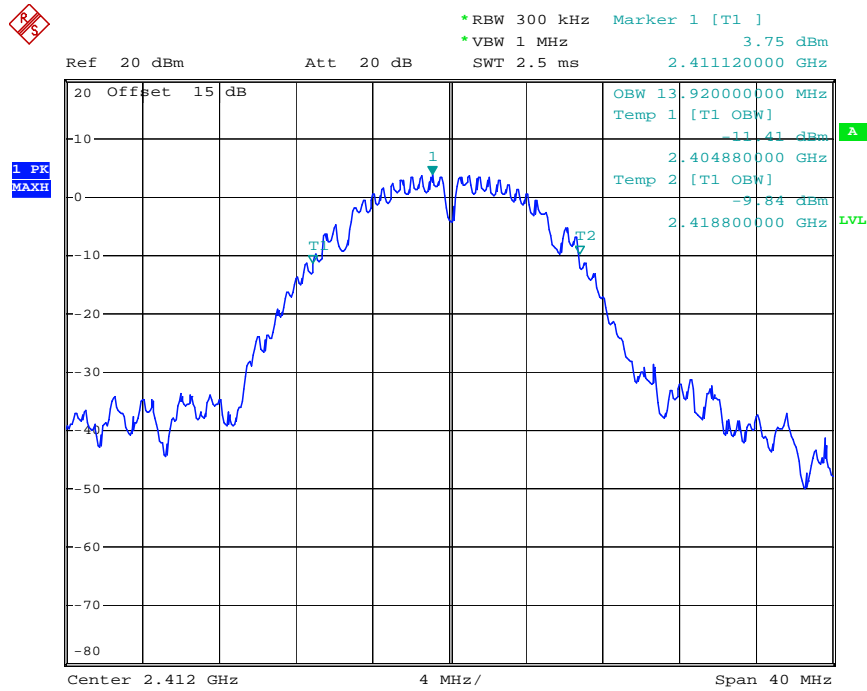

Date: 6.AUG.2019 13:29:53

802.11b Middle Channel 2437MHz

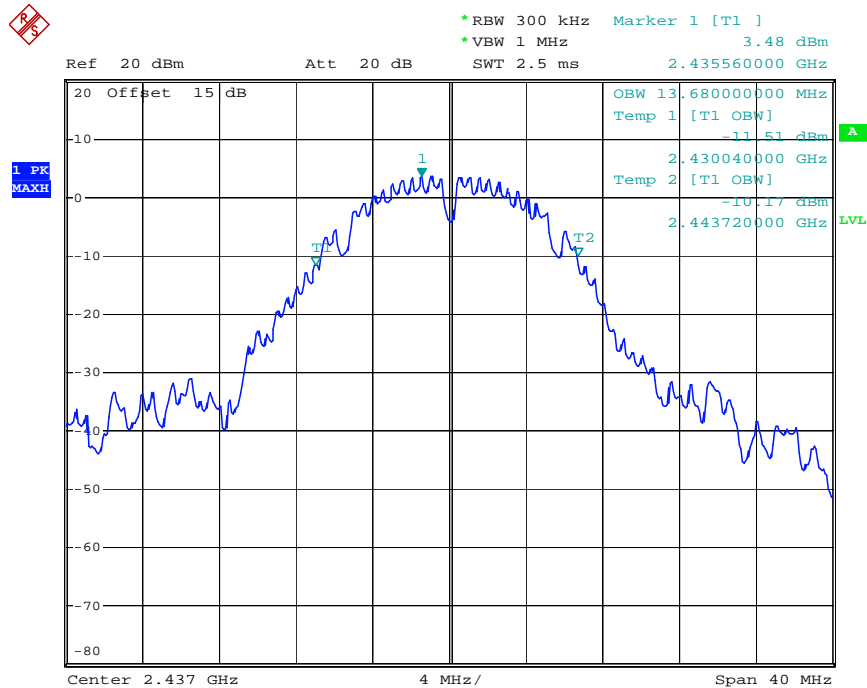

Date: 6.AUG.2019 13:29:31

802.11b High Channel 2462MHz

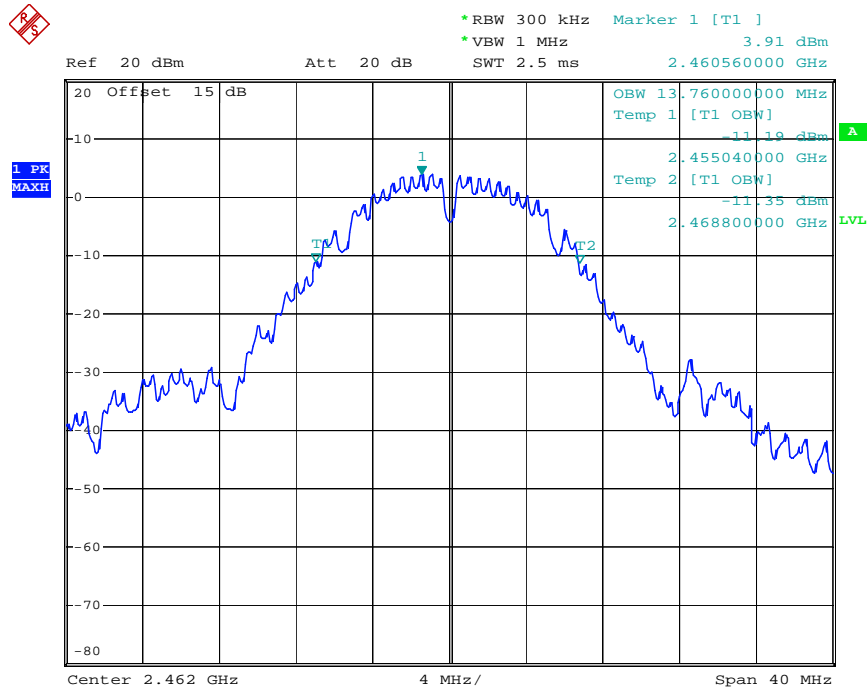

Date: 6.AUG.2019 13:29:03

802.11g Channel Low 2412MHz

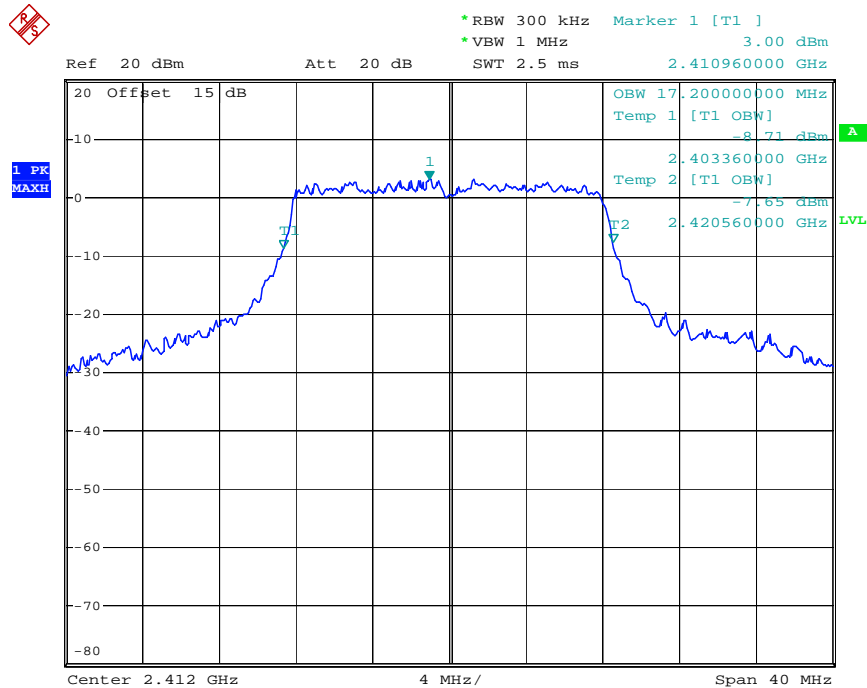

Date: 6.AUG.2019 13:27:44

802.11g Middle Channel 2437MHz

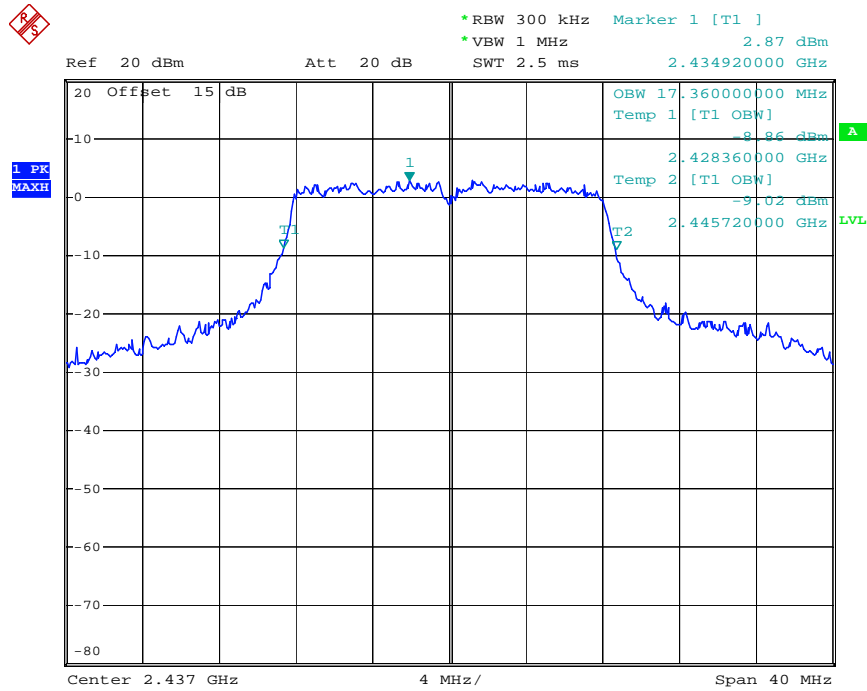

Date: 6.AUG.2019 13:28:08

802.11g High Channel 2462MHz

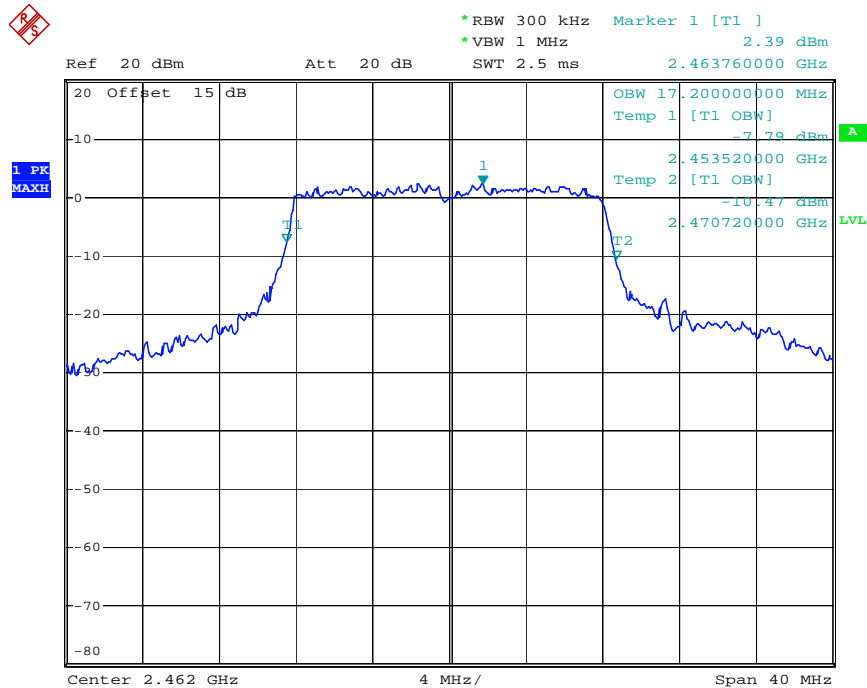

Date: 6.AUG.2019 13:28:39

802.11n(20MHz) Low Channel 2412MHz

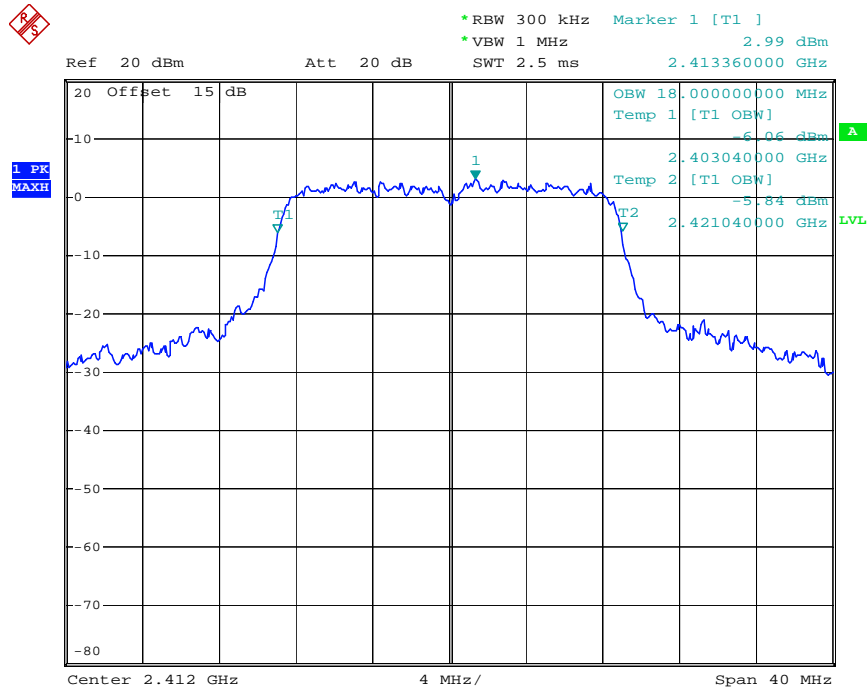

Date: 6.AUG.2019 13:27:14

802.11n(20MHz) Middle Channel 2437MHz

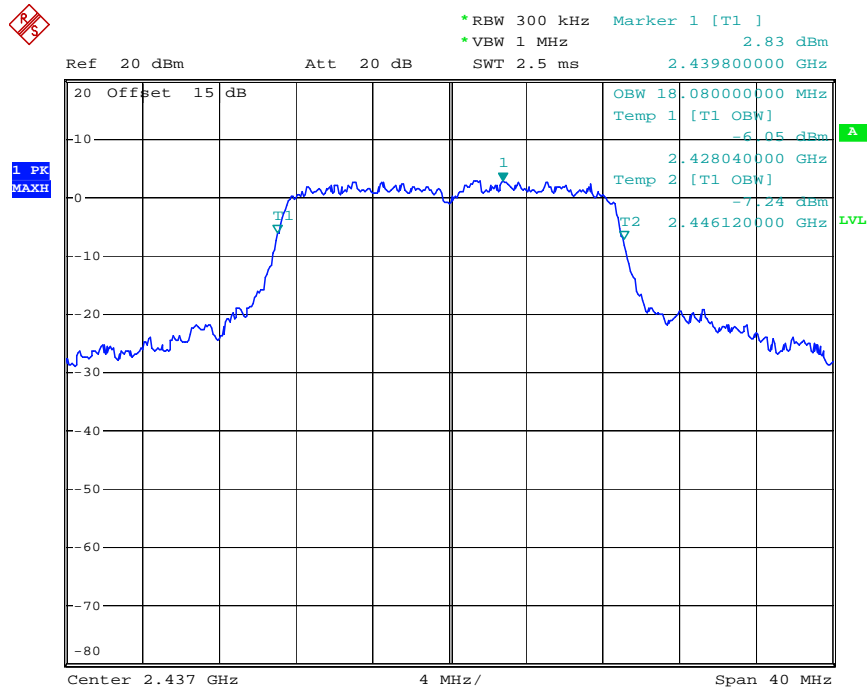

Date: 6.AUG.2019 13:26:51

802.11n(20MHz) High Channel 2462MHz

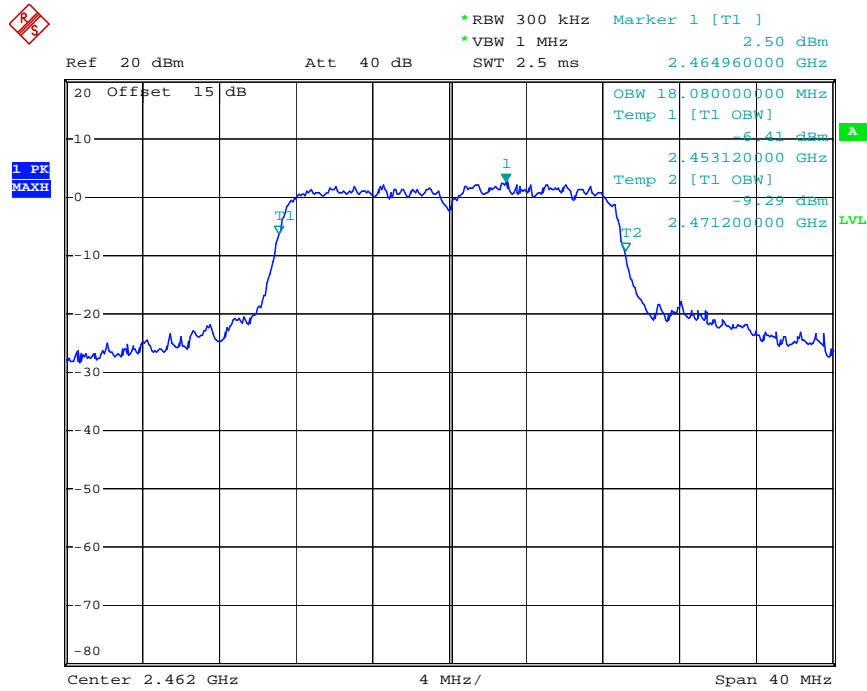

Date: 6.AUG.2019 13:26:20

7. DUTY CYCLE MEASUREMENT

7.1. Block Diagram of Test Setup

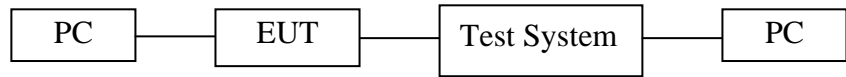

7.2. EUT Configuration on Measurement

The equipment are installed on the emission measurement to meet the commission requirements and operating regulations in a manner which tends to maximize its emission characteristics in normal application.

7.3. Operating Condition of EUT

7.3.1. Setup the EUT and simulator as shown as Section 7.1.

7.3.2. Turn on the power of all equipment.

7.3.3. Let the EUT work in TX modes measure it. The transmit frequency are 2412-2462MHz. We select 2437MHz TX frequency to transmit.

7.4. Test Procedure

Measurements of duty cycle and transmission duration shall be performed using one of the following techniques:

1. A diode detector and an oscilloscope that together have sufficiently short response time to permit accurate measurements of the on- and off-times of the transmitted signal.
2. The zero-span mode on a spectrum analyzer or EMI receiver if the response time and spacing between bins on the sweep are sufficient to permit accurate measurements of the on- and off-times of the transmitted signal
 - a. Set the center frequency of the instrument to the centre frequency of the transmission
 - b. Set $RBW \geq OBW$ if possible; otherwise, set RBW to the largest available value(10MHz).
 - c. Set detector = Peak or average.
 - d. The zero-span measurement method shall not be used unless both RBW and VBW are $> 50/T$ and the number of sweep points across duration T exceeds 100.
(For example, if VBW and/or RBW are limited to 3MHz, then the zero-span method of measuring duty cycle shall not be used if $T \leq 16.7$ microseconds.)

7.5. Test Result

The test was performed with 802.11b			
Channel	Frequency (MHz)	duty cycle(x)	10log(1/x)
Middle	2437	88.14%	0.55

The test was performed with 802.11g			
Channel	Frequency (MHz)	duty cycle(x)	10log(1/x)
Middle	2437	75.00%	1.25

The test was performed with 802.11n20			
Channel	Frequency (MHz)	duty cycle(x)	10log(1/x)
Middle	2437	78.95%	1.03

Note: The duty cycle's parameter settings for each mode(802.11b,g,n) are the same, Therefore, other channels can refer to the test data of the middle channel.

The spectrum analyzer plots are attached as below.

Duty cycle 802.11b Channel Middle 2437MHz

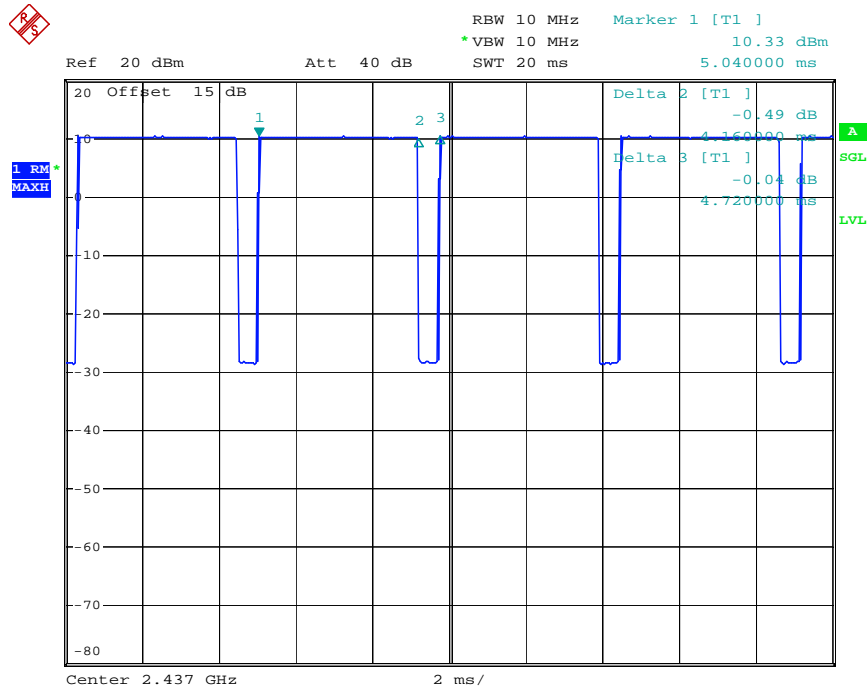

Date: 6.AUG.2019 13:37:43

802.11g Channel Middle 2437MHz

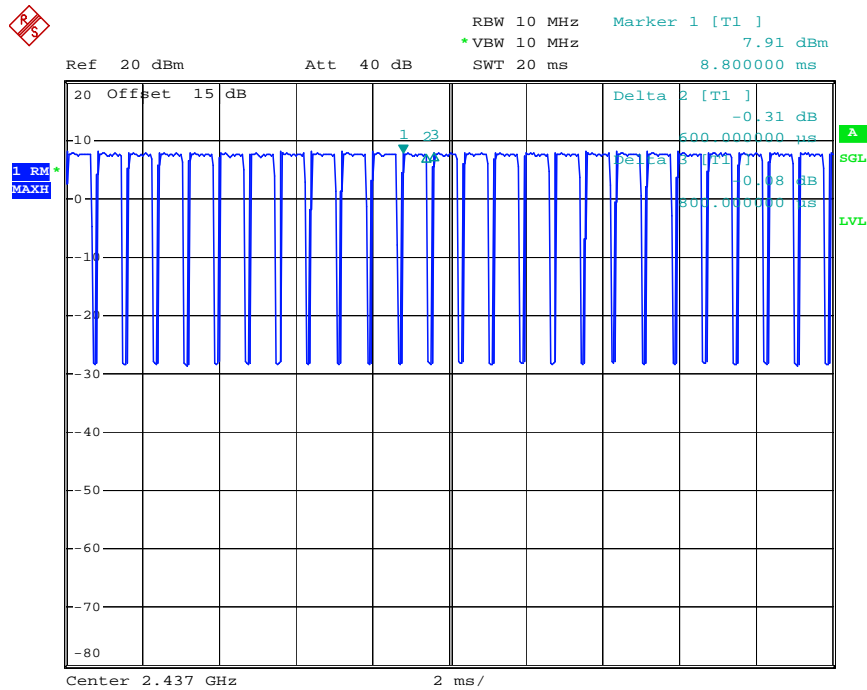

Date: 6.AUG.2019 13:39:00

802.11n20 Channel Middle 2437MHz

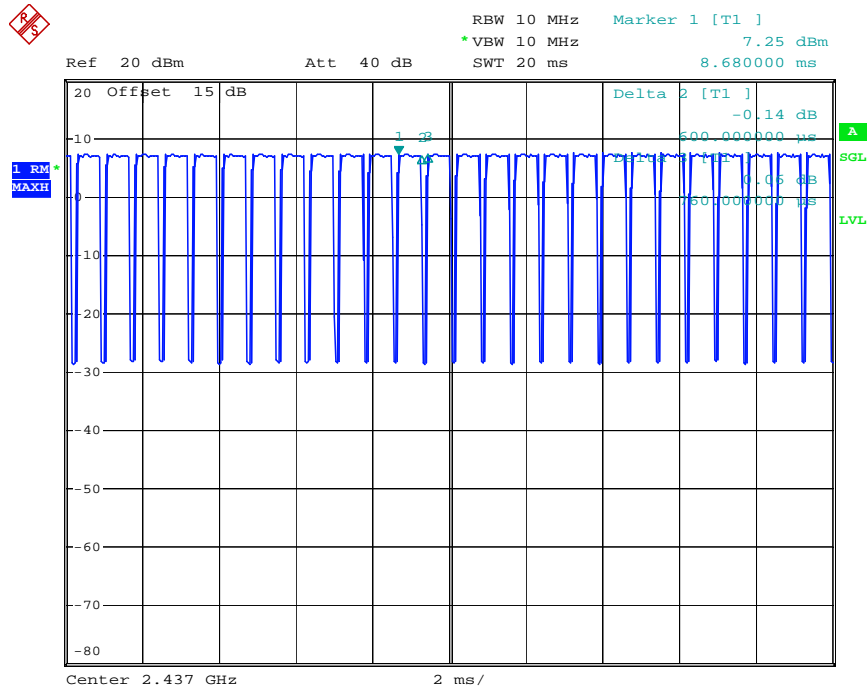

Date: 6.AUG.2019 13:39:42

8. POWER SPECTRAL DENSITY TEST

8.1. Block Diagram of Test Setup



8.2. The Requirement For Section 15.247(e)

Section 15.247(e): For digitally modulated systems, the power spectral density conducted from the intentional radiator to the antenna shall not be greater than 8 dBm in any 3 kHz band during any time interval of continuous transmission.

8.3. EUT Configuration on Measurement

The equipment are installed on the emission Measurement to meet the commission requirements and operating regulations in a manner which tends to maximize its emission characteristics in normal application.

8.4. Operating Condition of EUT

8.4.1. Setup the EUT and simulator as shown as Section 8.1.

8.4.2. Turn on the power of all equipment.

8.4.3. Let the EUT work in TX modes measure it. The transmit frequency are 2412-2462MHz. We select 2412MHz, 2437MHz and 2462MHz TX frequency to transmit.

8.5. Test Procedure

8.5.1. The transmitter output was connected to the spectrum analyzer through a low loss cable.

8.5.2. Measurement Procedure PKPSD:

This procedure must be used if maximum peak conducted output power was used to demonstrate compliance to the fundamental output power limit, and is optional if the maximum (average) conducted output power was used to demonstrate compliance.

1. Set analyzer center frequency to DTS channel center frequency.
2. Set the span to 1.5 times the DTS channel bandwidth.
3. Set the RBW $3 \text{ kHz} \leq \text{RBW} \leq 100 \text{ kHz}$.

4. Set the VBW $\geq 3 \times$ RBW.
5. Detector = peak.
6. Sweep time = auto couple.
7. Trace mode = max hold.
8. Allow trace to fully stabilize.
9. Use the peak marker function to determine the maximum amplitude level.
10. If measured value exceeds limit, reduce RBW (no less than 3 kHz) and repeat.

8.5.3.Measurement the maximum power spectral density.

8.6.Test Result

PASS

Note: Single antenna transmit in 802.11b and 802.11g mode

Both antennas are transmitted at the same time in 802.11n mode.

We have recorded the worst case value in the report.

The test was performed with 802.11b					
Channel	Frequency (MHz)	Power Spectral Density(dBm)	10log(1/ duty cycle)	Final Power Spectral Density(dBm)	Limits (dBm)
Low	2412	-20.03	0.55	-19.48	8 dBm
Middle	2437	-19.88	0.55	-19.33	8 dBm
High	2462	-20.34	0.55	-19.79	8 dBm

The test was performed with 802.11g					
Channel	Frequency (MHz)	Power Spectral Density(dBm)	10log(1/ duty cycle)	Final Power Spectral Density(dBm)	Limits (dBm)
Low	2412	-23.65	1.25	-22.40	8 dBm
Middle	2437	-23.14	1.25	-21.89	8 dBm
High	2462	-23.49	1.25	-22.24	8 dBm

The test was performed with 802.11n(20MHz)					
Channel	Frequency (MHz)	Power Spectral Density(dBm)	10log(1/ duty cycle)	Final Power Spectral Density(dBm)	Limits (dBm)
Low	2412	-23.45	1.03	-22.42	8 dBm
Middle	2437	-23.68	1.03	-22.65	8 dBm
High	2462	-23.93	1.03	-22.90	8 dBm

The spectrum analyzer plots are attached as below.

802.11b Low Channel 2412MHz

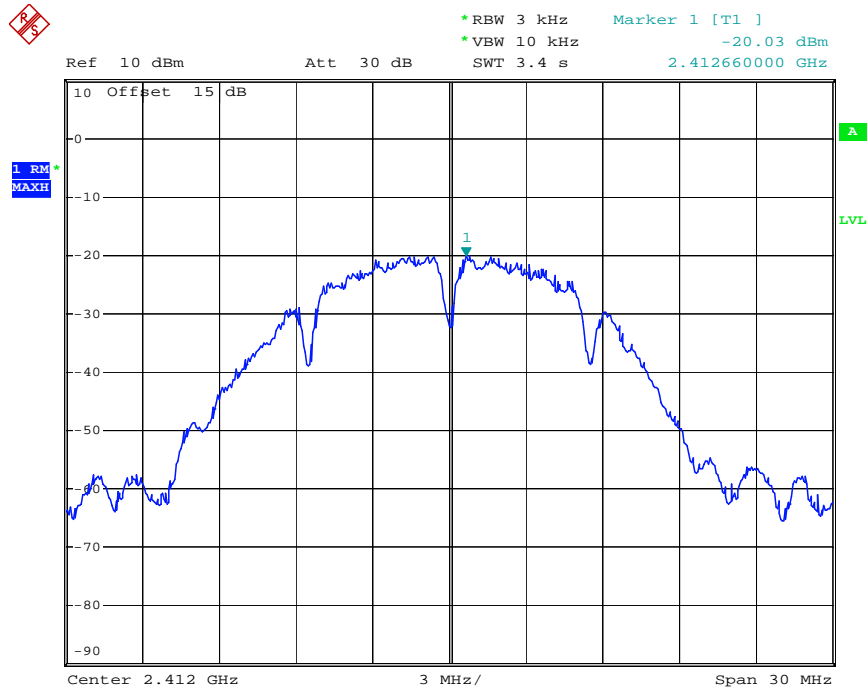

Date: 6.AUG.2019 13:41:22

802.11b Middle Channel 2437MHz

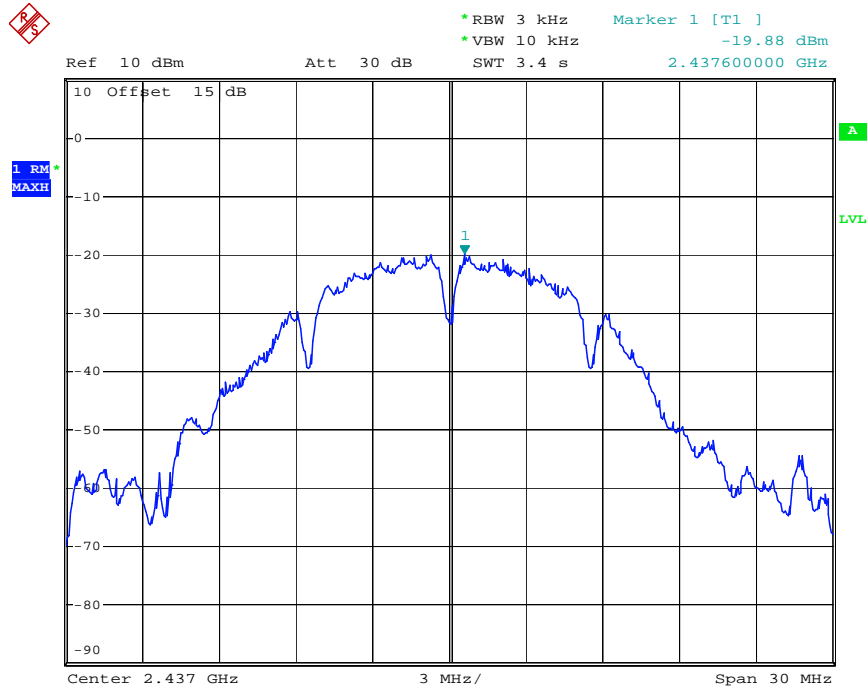

Date: 6.AUG.2019 13:41:49

802.11b High Channel 2462MHz

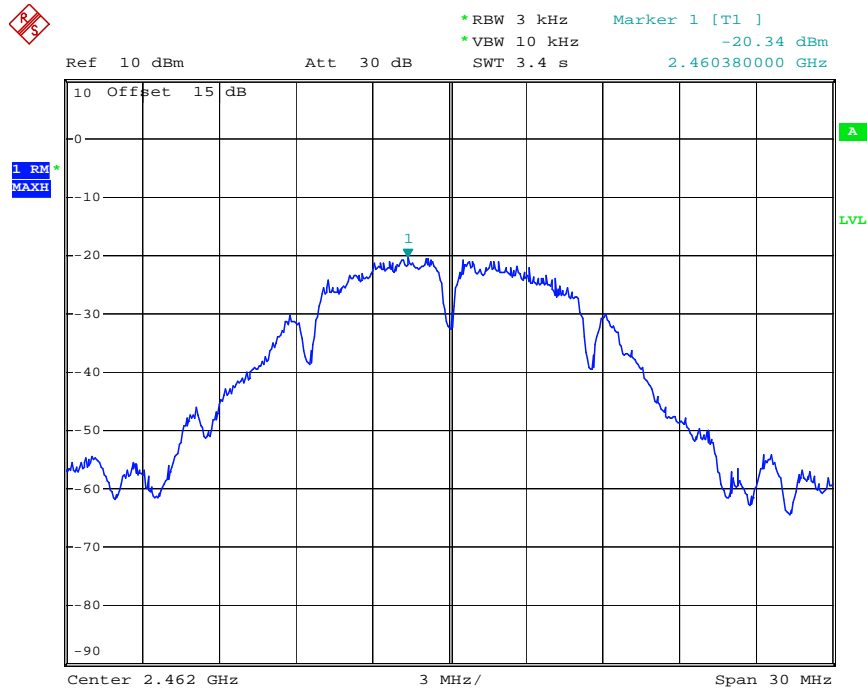

Date: 6.AUG.2019 13:42:10

802.11g Low Channel 2412MHz

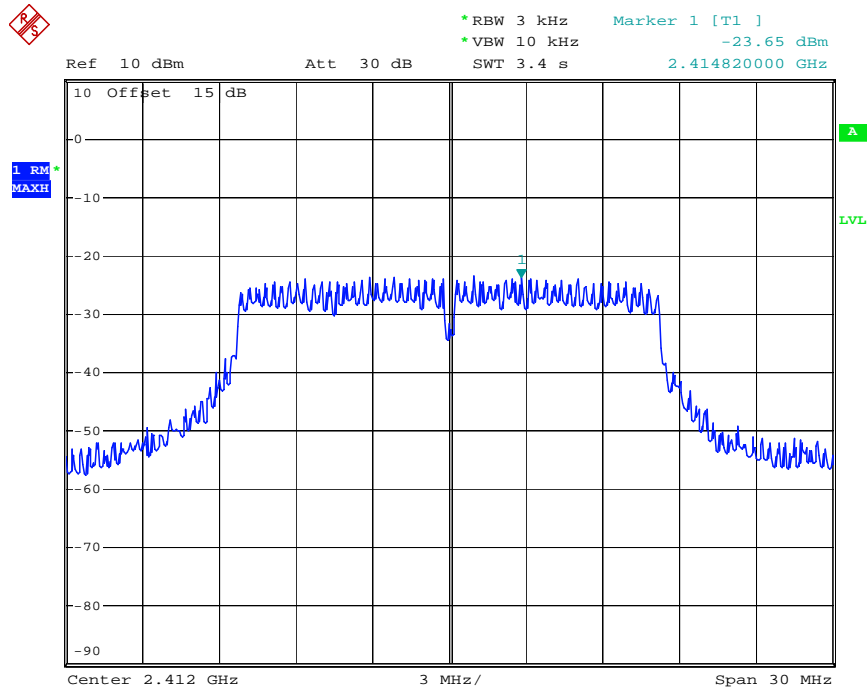

Date: 6.AUG.2019 13:43:25

802.11g Middle Channel 2437MHz

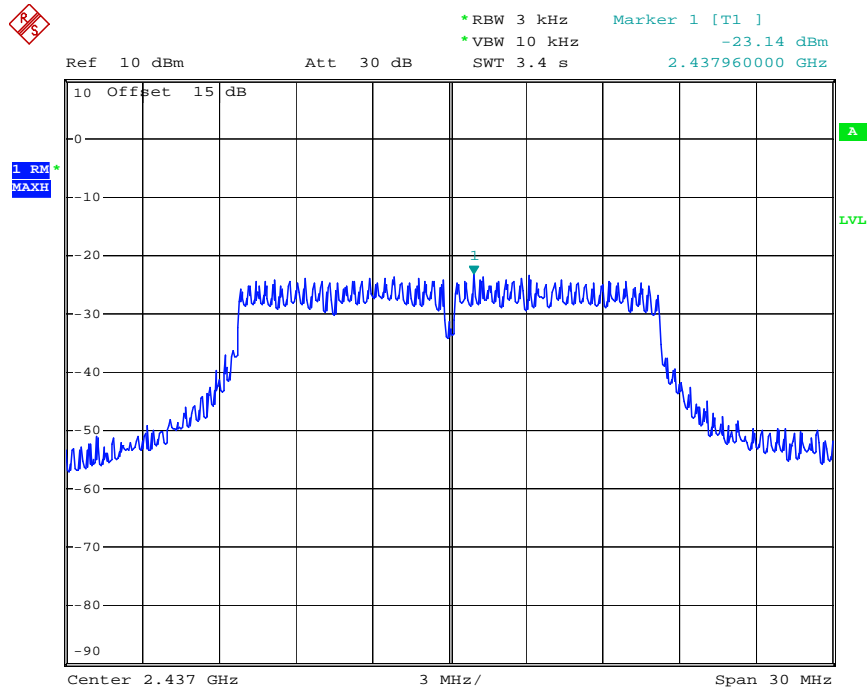

Date: 6.AUG.2019 13:43:02

802.11g High Channel 2462MHz

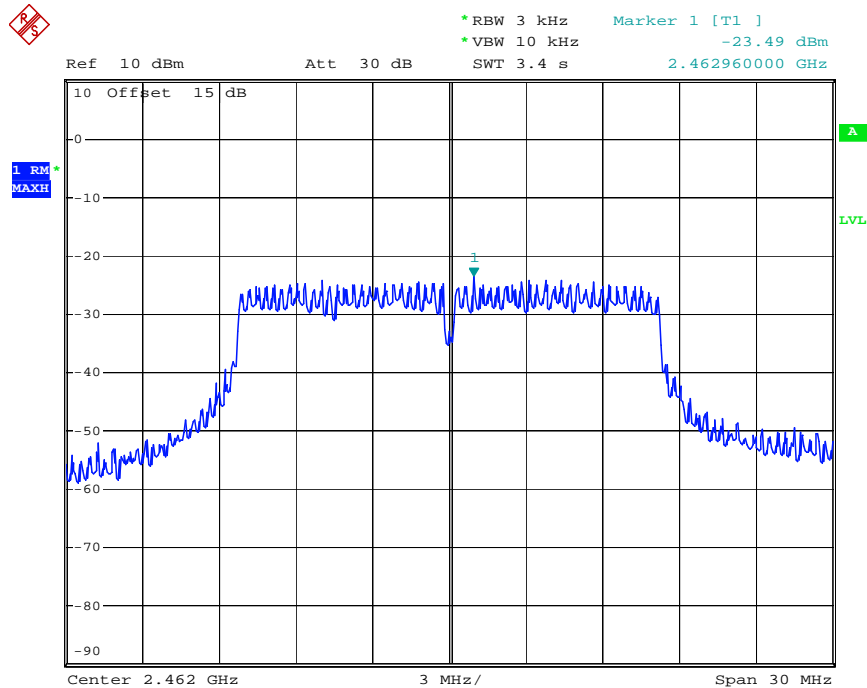

Date: 6.AUG.2019 13:42:36

802.11n(20MHz) Low Channel 2412MHz

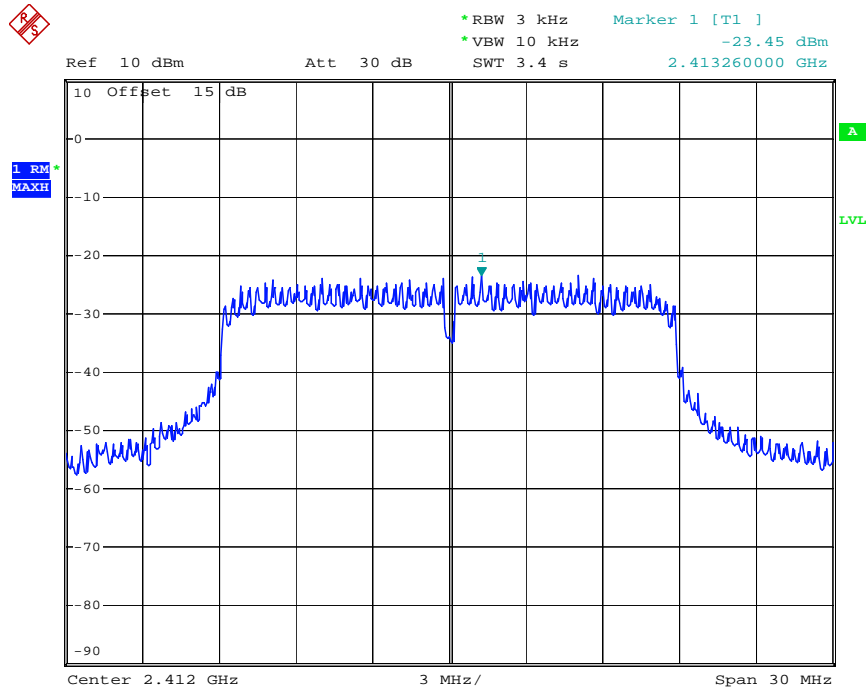

Date: 6.AUG.2019 13:43:56

802.11n(20MHz) Middle Channel 2437MHz

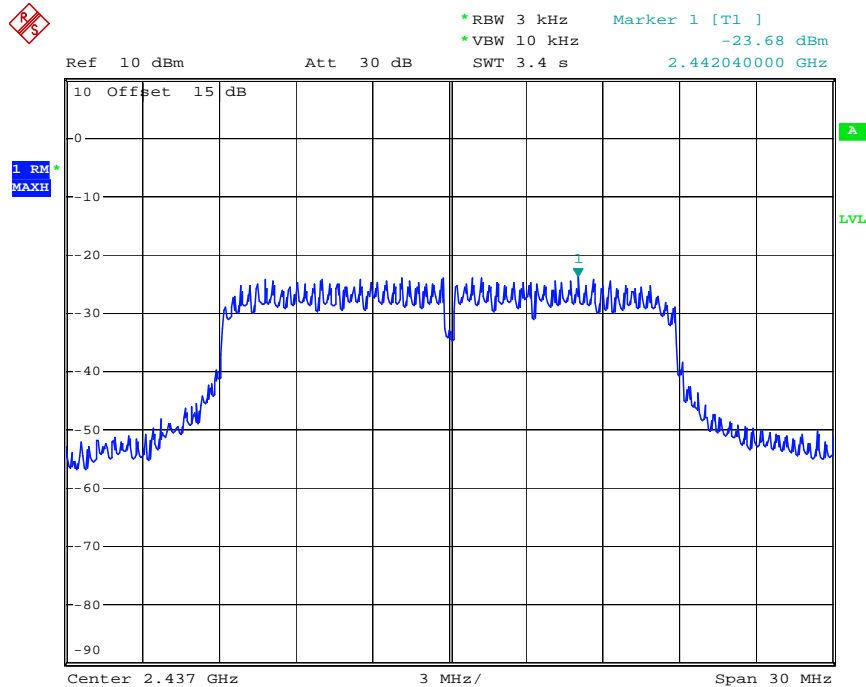

Date: 6.AUG.2019 13:44:18

802.11n(20MHz) High Channel 2462MHz

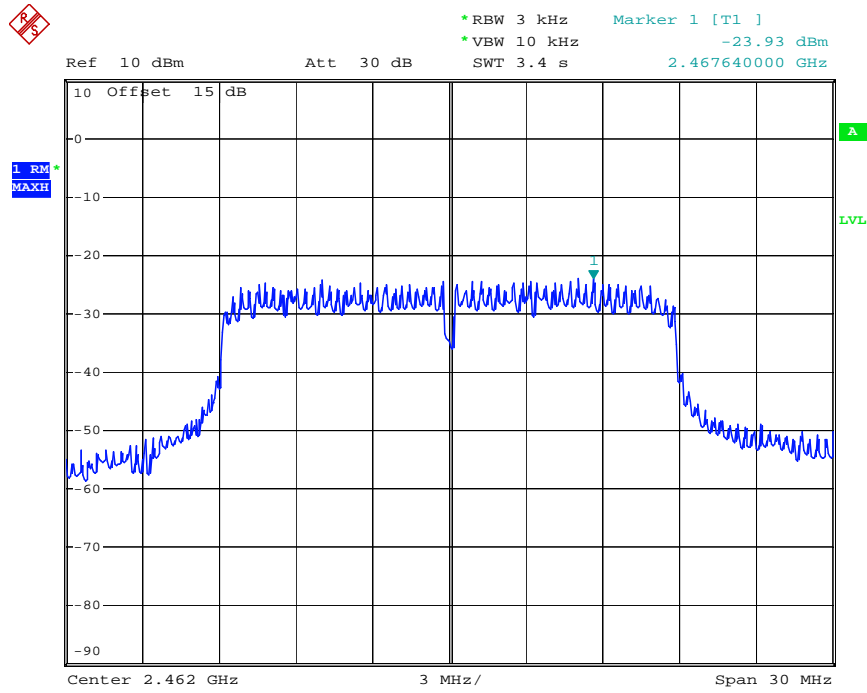

Date: 6.AUG.2019 13:44:39

9. MAXIMUM CONDUCTED (AVERAGE) OUTPUT POWER

9.1. Block Diagram of Test Setup

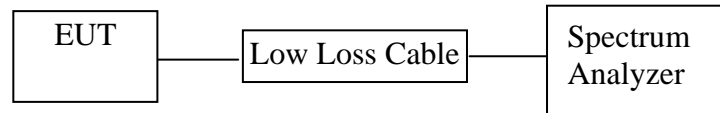

9.2. The Requirement For Section 15.247(b)(3)

Section 15.247(b)(3): For systems using digital modulation in the 902-928MHz, 2400-2483.5MHz, and 5725-5850MHz bands: 1 Watt.

9.3. EUT Configuration on Measurement

The equipment is installed on the emission Measurement to meet the commission requirements and operating regulations in a manner which tends to maximize its emission characteristics in normal application.

9.4. Operating Condition of EUT

9.4.1. Setup the EUT and simulator as shown as Section 9.1.

9.4.2. Turn on the power of all equipment.

9.4.3. Let the EUT work in TX modes measure it. The transmit frequency are 2412-2462MHz. We select 2412MHz, 2437MHz and 2462MHz TX frequency to transmit.

9.5. Test Procedure

9.5.1. The EUT was tested according to DTS test procedure of April 02, 2019 KDB558074 D01 DTS Meas Guidance v0502 for compliance to FCC 47CFR 15.247 requirements.

9.5.2. The transmitter output was connected to the spectrum analyzer through a low loss cable.

9.5.3. Set RBW = 1-5% of the OBW, not to exceed 1 MHz, VBW \geq 3 x RBW, Sweep time = auto, Set span to at least 1.5 times the OBW, Detector = RMS.

9.5.4. Measurement the Maximum conducted (average) output power.

9.6.Test Result

Final power= Ave output power+10log(1/ duty cycle)

The test was performed with 802.11b					
Frequency (MHz)	Ave output power (dBm)	10log(1/ duty cycle)	Final power (dBm)	Final power (W)	FCC Limits dBm / W
2412	15.07	0.55	15.62	0.0365	30 dBm / 1 W
2437	15.16	0.55	15.71	0.0372	30 dBm / 1 W
2462	14.92	0.55	15.47	0.0352	30 dBm / 1 W

The test was performed with 802.11g					
Frequency (MHz)	Ave output power (dBm)	10log(1/ duty cycle)	Final power (dBm)	Final power (W)	FCC Limits dBm / W
2412	15.42	1.25	16.67	0.0465	30 dBm / 1 W
2437	15.48	1.25	16.73	0.0471	30 dBm / 1 W
2462	14.89	1.25	16.14	0.0411	30 dBm / 1 W

The test was performed with 802.11n(20MHz)					
Frequency (MHz)	Ave output power (dBm)	10log(1/ duty cycle)	Final power (dBm)	Final power (W)	FCC Limits dBm / W
2412	15.37	1.03	16.40	0.0437	30 dBm / 1 W
2437	15.42	1.03	16.45	0.0442	30 dBm / 1 W
2462	14.96	1.03	15.99	0.0397	30 dBm / 1 W

The spectrum analyzer plots are attached as below.

802.11b Low Channel 2412MHz

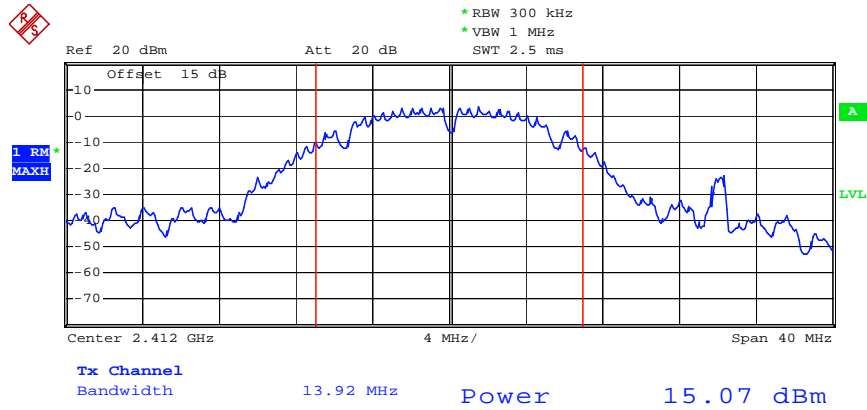

Date: 6.AUG.2019 13:46:30

802.11b Middle Channel 2437MHz

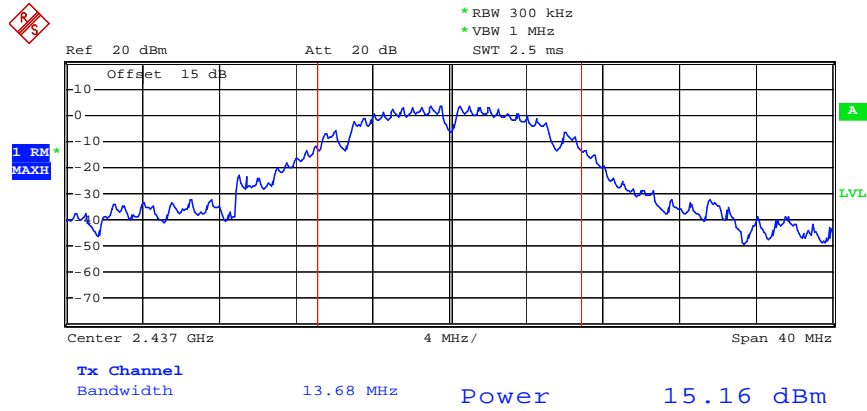

Date: 6.AUG.2019 13:47:27

802.11b High Channel 2462MHz

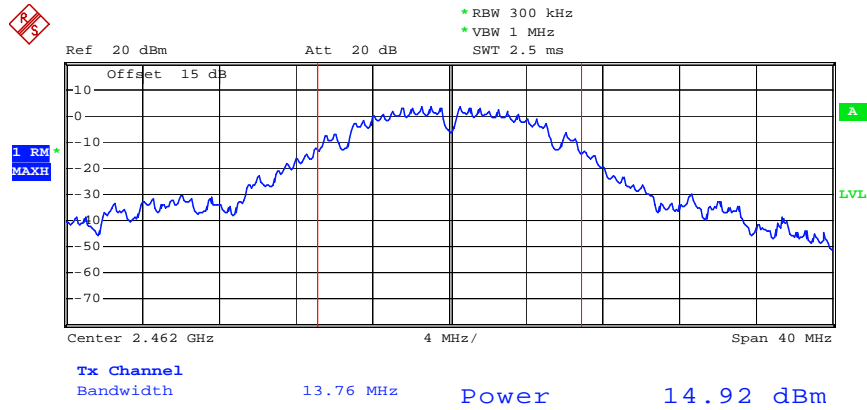

Date: 6.AUG.2019 13:48:30

802.11g Low Channel 2412MHz

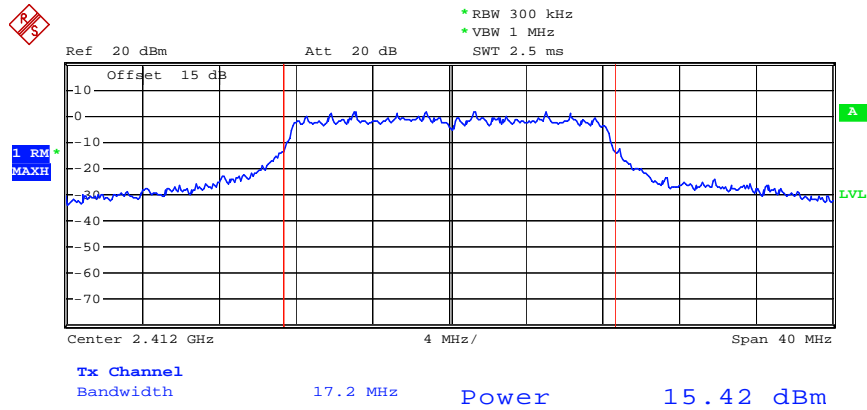

Date: 6.AUG.2019 13:50:45

802.11n(20MHz) Low Channel 2412MHz

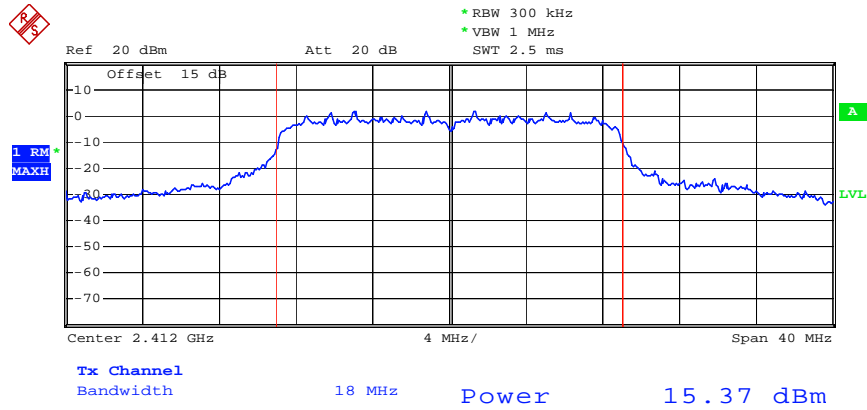

Date: 6.AUG.2019 13:51:33

802.11n(20MHz) Middle Channel 2437MHz

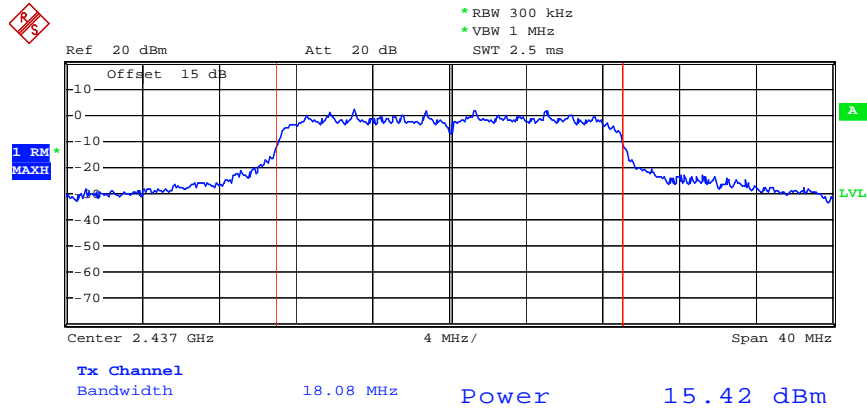

Date: 6.AUG.2019 13:52:25

802.11n(20MHz) High Channel 2462MHz

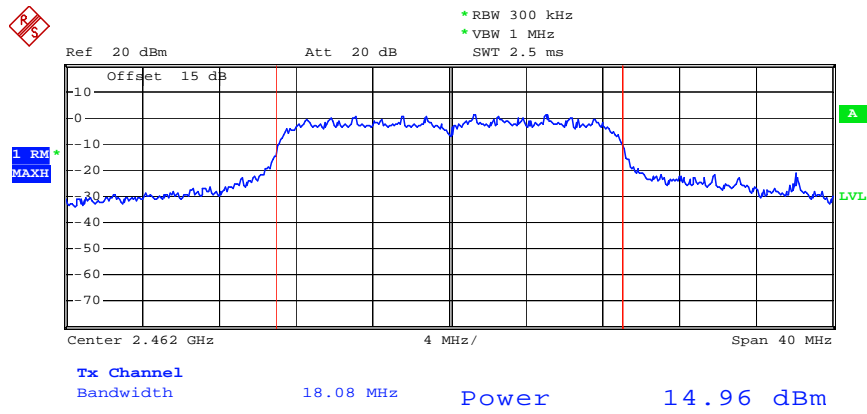

Date: 6.AUG.2019 13:53:16

10. RADIATED SPURIOUS EMISSION TEST

10.1. Block Diagram of Test Setup

10.1.1. Block diagram of connection between the EUT and peripherals

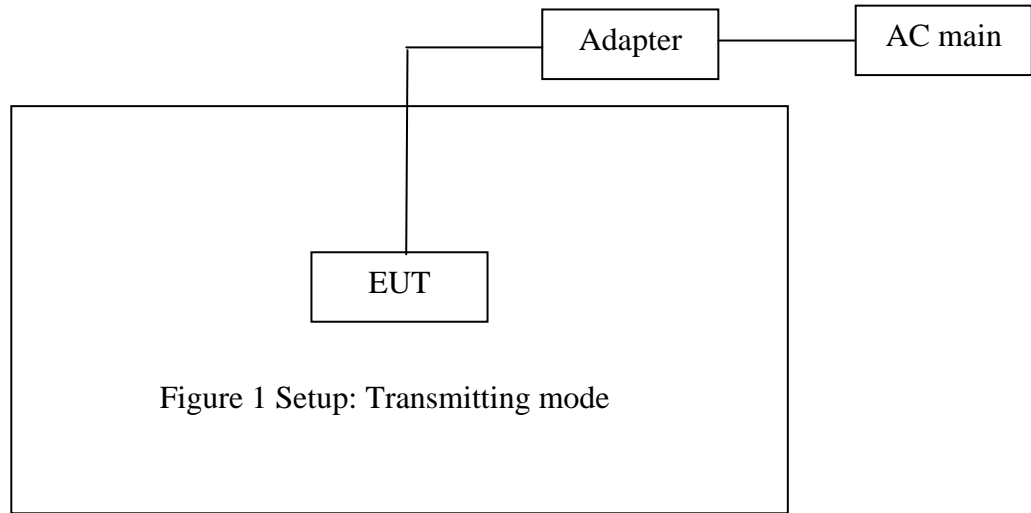

10.1.2. Semi-Anechoic Chamber Test Setup Diagram

(A) Radiated Emission Test Set-Up, Frequency below 30MHz

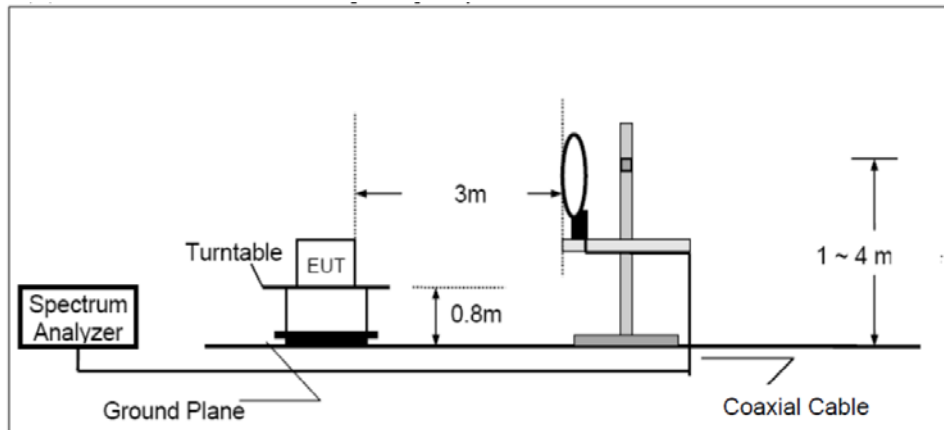

(B) Radiated Emission Test Set-Up, Frequency below 1GHz

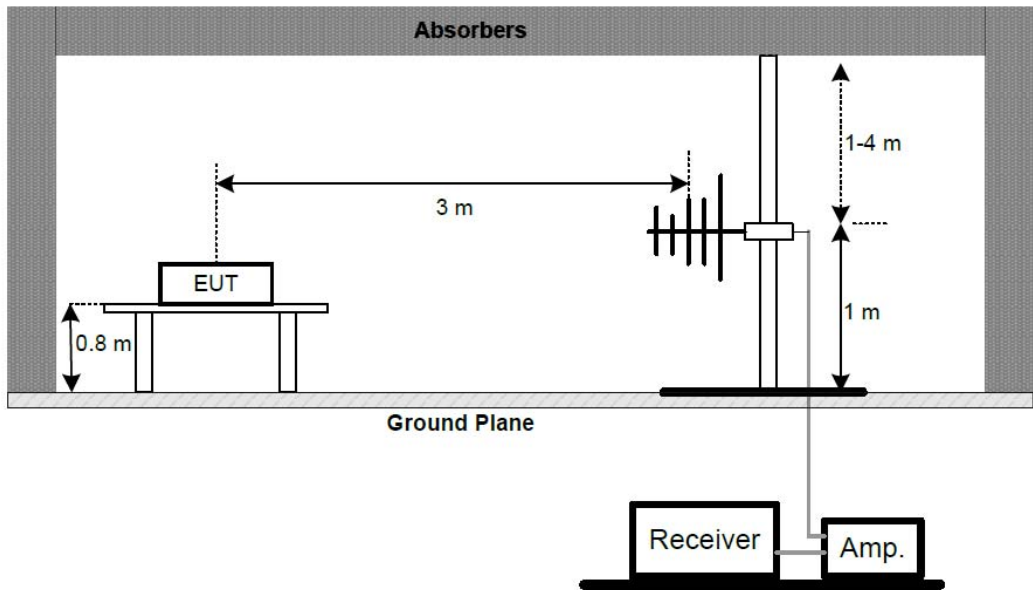

Above 1GHz:

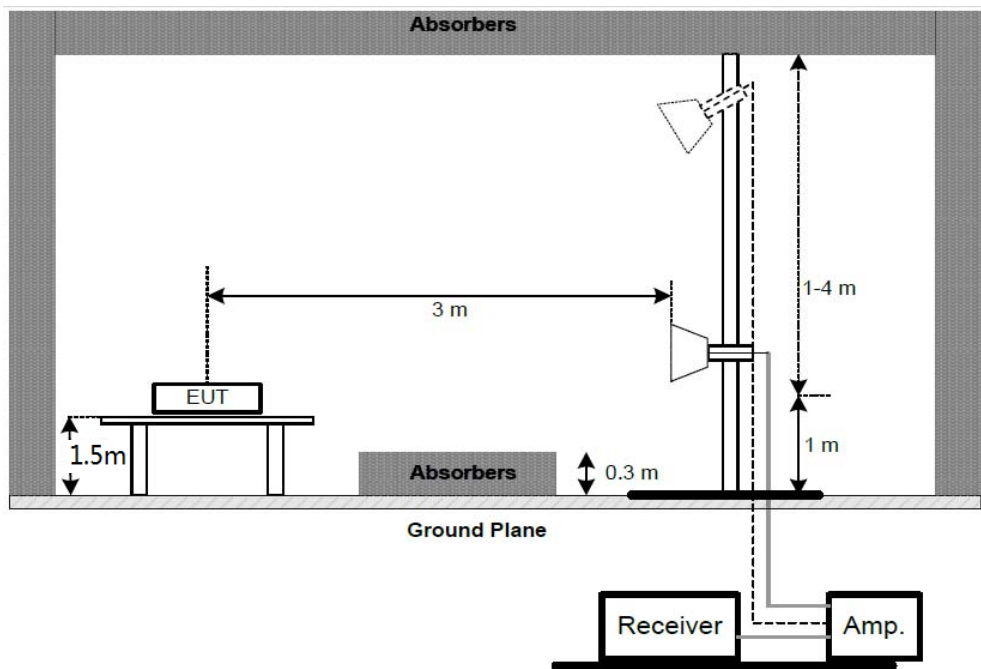

10.2.The Limit For Section 15.247(d)

Section 15.247(d): In any 100 kHz bandwidth outside the frequency band in which the spread spectrum or digitally modulated intentional radiator is operating, the radio frequency power that is produced by the intentional radiator shall be at least 20 dB below that in the 100 kHz bandwidth within the band that contains the highest level of the desired power, based on either an RF conducted or a radiated measurement, provided the transmitter demonstrates compliance with the peak conducted power limits. If the transmitter complies with the conducted power limits based on the use of RMS averaging over a time interval, as permitted under paragraph (b)(3) of this section, the attenuation required under this paragraph shall be 30 dB instead of 20 dB. Attenuation below the general limits specified in Section 15.209(a) is not required. In addition, radiated emissions which fall in the restricted bands, as defined in Section 15.205(a), must also comply with the radiated emission limits specified in Section 15.209(a).

10.3.Restricted bands of operation

10.3.1.FCC Part 15.205 Restricted bands of operation

(a) Except as shown in paragraph (d) of this section, Only spurious emissions are permitted in any of the frequency bands listed below:

MHz	MHz	MHz	GHz
0.090-0.110	16.42-16.423	399.9-410	4.5-5.15
¹ 0.495-0.505	16.69475-16.69525	608-614	5.35-5.46
2.1735-2.1905	16.80425-16.80475	960-1240	7.25-7.75
4.125-4.128	25.5-25.67	1300-1427	8.025-8.5
4.17725-4.17775	37.5-38.25	1435-1626.5	9.0-9.2
4.20725-4.20775	73-74.6	1645.5-1646.5	9.3-9.5
6.215-6.218	74.8-75.2	1660-1710	10.6-12.7
6.26775-6.26825	108-121.94	1718.8-1722.2	13.25-13.4
6.31175-6.31225	123-138	2200-2300	14.47-14.5
8.291-8.294	149.9-150.05	2310-2390	15.35-16.2
8.362-8.366	156.52475-156.52525	2483.5-2500	17.7-21.4
8.37625-8.38675	156.7-156.9	2690-2900	22.01-23.12
8.41425-8.41475	162.0125-167.17	3260-3267	23.6-24.0
12.29-12.293	167.72-173.2	3332-3339	31.2-31.8
12.51975-12.52025	240-285	3345.8-3358	36.43-36.5
12.57675-12.57725	322-335.4	3600-4400	(²)
13.36-13.41			

¹Until February 1, 1999, this restricted band shall be 0.490-0.510

²Above 38.6

(b) Except as provided in paragraphs (d) and (e), the field strength of emission appearing within these frequency bands shall not exceed the limits shown in Section 15.209. At frequencies equal to or less than 1000MHz, Compliance with the limits in Section 15.209 shall be demonstrated using measurement instrumentation employing a CISPR quasi-peak detector. Above 1000MHz, compliance with the emission limits in Section 15.209 shall be demonstrated based on the average value of the measured emissions. The provisions in Section 15.35 apply to these measurements.

10.4. Configuration of EUT on Measurement

The equipment are installed on Radiated Emission Measurement to meet the commission requirements and operating regulations in a manner which tends to maximize its emission characteristics in normal application.

10.5. Operating Condition of EUT

10.5.1. Setup the EUT and simulator as shown as Section 10.1.

10.5.2. Turn on the power of all equipment.

10.5.3. Let the EUT work in TX modes measure it. The transmit frequency are 2412-2462MHz. We select 2412MHz, 2437MHz and 2462MHz TX frequency to transmit.

10.6. Test Procedure

The EUT and its simulators are placed on a turntable, which is 0.8 meter high above ground (Below 1GHz). The EUT and its simulators are placed on a turntable, which is 1.5 meter high above ground (Above 1GHz). The turntable can rotate 360 degrees to determine the position of the maximum emission level. EUT is set 3.0 meters away from the receiving antenna, which is mounted on an antenna tower. The antenna can be moved up and down between 1.0 meter and 4 meters to find out the maximum emission level. Broadband antenna (calibrated bi-log antenna) is used as receiving antenna. Both horizontal and vertical polarizations of the antenna are set on measurement. In order to find the maximum emission levels, all of the EUT location must be manipulated according to ANSI C63.10:2013 on radiated emission measurement. The EUT was tested in 3 orthogonal planes.

The worst-case data rate for this channel to be 1Mbps for 802.11b mode and 6Mbps for 802.11g mode and 150Mbps for 802.11n mode, based on previous with 802.11 WLAN product design architectures.

The frequency range from 30MHz to 25000MHz is checked.

Result = Reading + Corrected Factor

Where Corrected Factor = Antenna Factor + Cable Loss – Amplifier Gain

During the radiated emission test, the spectrum analyzer was set with the following configurations:

1. The resolution bandwidth and video bandwidth of test receiver/spectrum analyzer is 120kHz for Quasi-peak at frequency below 1GHz.
2. The resolution bandwidth of test receiver/spectrum analyzer is 1MHz and video bandwidth is 3MHz for peak measurement with peak detector at frequency above 1GHz.
3. The resolution bandwidth of test receiver/spectrum analyzer is 1MHz and video bandwidth is 10Hz for Average measurement with peak detection at frequency above 1GHz.
4. All modes of operation were investigated and the worst-case emissions

are reported.

10.7. The Field Strength of Radiation Emission Measurement Results

Note: 1. Emissions attenuated more than 20 dB below the permissible value are not reported.

2. *: Denotes restricted band of operation.

3. The EUT is tested radiation emission at each test mode (802.11b/g/n) in three axes. The worst emissions are reflected in the following plots.

4. The radiation emissions from 18-25GHz are not reported, because the test values lower than the limits of 20dB

5. The average measurement was not performed when peak measured data under the limit of average detection.

Below 1G



ACCURATE TECHNOLOGY CO., LTD.

F1,Bldg,A,Changyuan New Material Port Keyuan Rd,
Science & Industry Park,Nanshan Shenzhen,P.R.China

Site: 2# Chamber

Tel:+86-0755-26503290

Fax:+86-0755-26503396

Job No.: FRANK2019 #1367	Polarization: Horizontal
Standard: FCC Class B 3M Radiated	Power Source: AC 120V/60Hz
Test item: Radiation Test	Date: 19/08/12/
Temp.(C)/Hum.(%) 25 C / 55 %	Time: 9/42/50
EUT: SMART WI-FI HUMIDIFIER	Engineer Signature:
Mode: TX 2412MHz	Distance: 3m
Model: MW3038	
Manufacturer: Guangdong Mixwell Technology Co.,Ltd.	

Note: Report NO.:ATE20191168

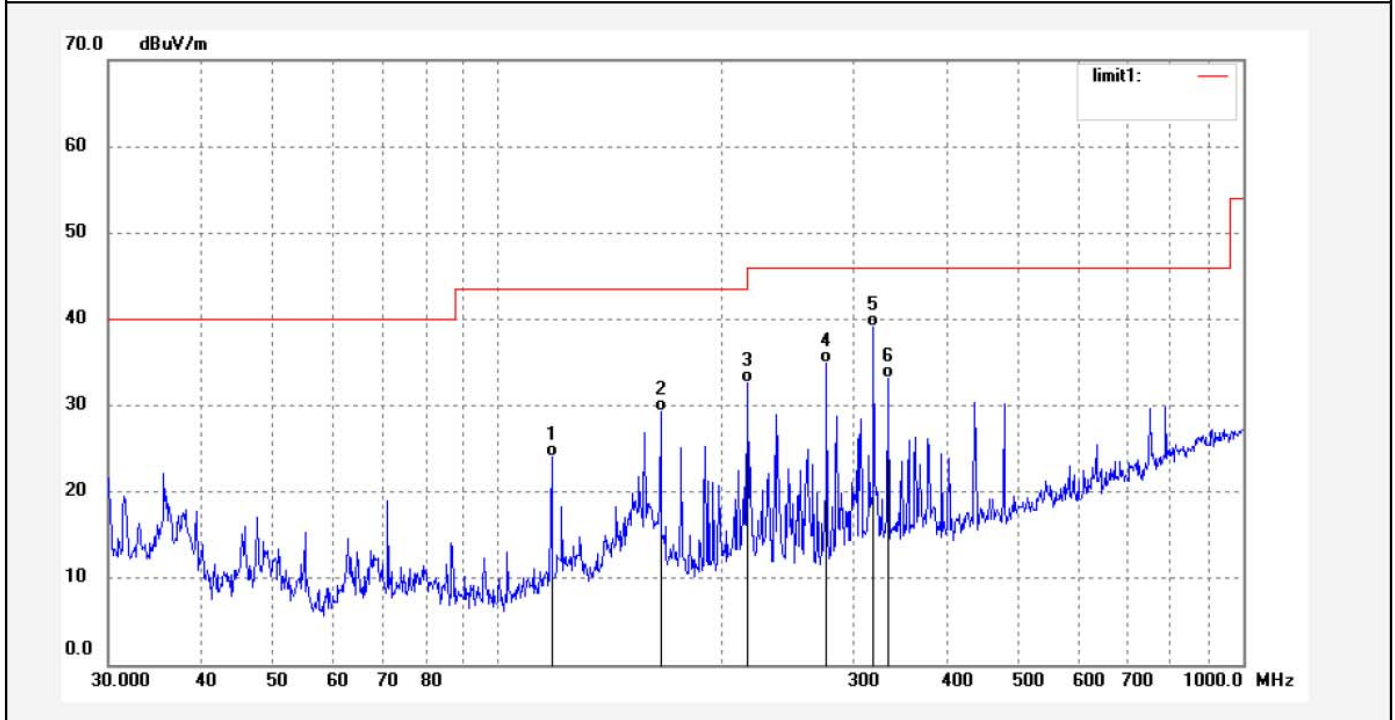

No.	Freq. (MHz)	Reading (dBuV/m)	Factor (dB)	Result (dBuV/m)	Limit (dBuV/m)	Margin (dB)	Detector	Height (cm)	Degree (deg.)	Remark
1	118.0956	51.45	-27.40	24.05	43.50	-19.45	QP	200	200	
2	165.4713	55.74	-26.48	29.26	43.50	-14.24	QP	200	110	
3	216.1194	56.74	-24.05	32.69	46.00	-13.31	QP	200	201	
4	276.3817	57.17	-22.33	34.84	46.00	-11.16	QP	200	331	
5	319.2071	59.70	-20.65	39.05	46.00	-6.95	QP	200	269	
6	334.1254	53.09	-19.94	33.15	46.00	-12.85	QP	200	103	

Job No.: FRANK2019 #1366

Standard: FCC Class B 3M Radiated

Test item: Radiation Test

Temp.(C)/Hum.(%) 25 C / 55 %

EUT: SMART WI-FI HUMIDIFIER

Mode: TX 2412MHz

Model: MW3038

Manufacturer: Guangdong Mixwell Technology Co.,Ltd.

Polarization: Vertical

Power Source: AC 120V/60Hz

Date: 19/08/12/

Time: 9/41/50

Engineer Signature:

Distance: 3m

Note: Report NO.:ATE20191168

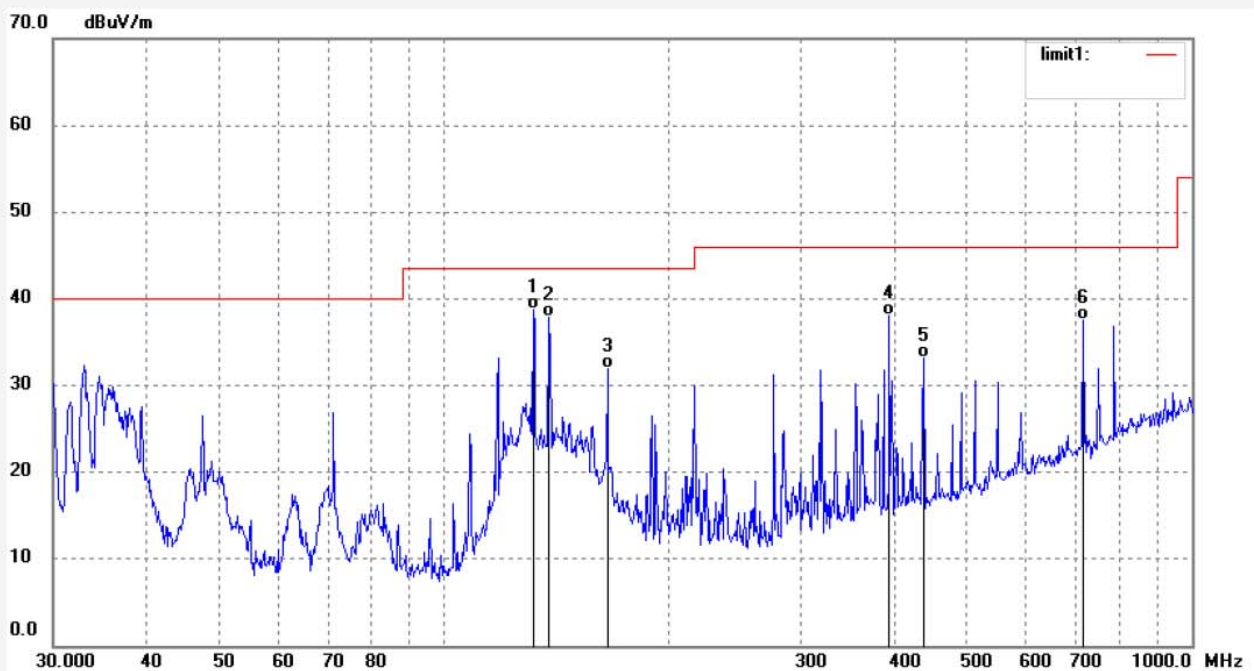

No.	Freq. (MHz)	Reading (dBuV/m)	Factor (dB)	Result (dBuV/m)	Limit (dBuV/m)	Margin (dB)	Detector	Height (cm)	Degree (deg.)	Remark
1	131.6853	66.51	-27.75	38.76	43.50	-4.74	QP	100	223	
2	138.3249	65.79	-27.91	37.88	43.50	-5.62	QP	100	85	
3	165.4713	58.45	-26.48	31.97	43.50	-11.53	QP	100	201	
4	394.1197	56.40	-18.41	37.99	46.00	-8.01	QP	100	112	
5	437.9316	50.69	-17.58	33.11	46.00	-12.89	QP	100	93	
6	716.2038	48.70	-11.09	37.61	46.00	-8.39	QP	100	103	

Job No.: FRANK2019 #1368

Standard: FCC Class B 3M Radiated

Test item: Radiation Test

Temp.(C)/Hum.(%) 25 C / 55 %

EUT: SMART WI-FI HUMIDIFIER

Mode: TX 2437MHz

Model: MW3038

Manufacturer: Guangdong Mixwell Technology Co.,Ltd.

Polarization: Horizontal

Power Source: AC 120V/60Hz

Date: 19/08/12/

Time: 9/42/50

Engineer Signature:

Distance: 3m

Note: Report NO.:ATE20191168

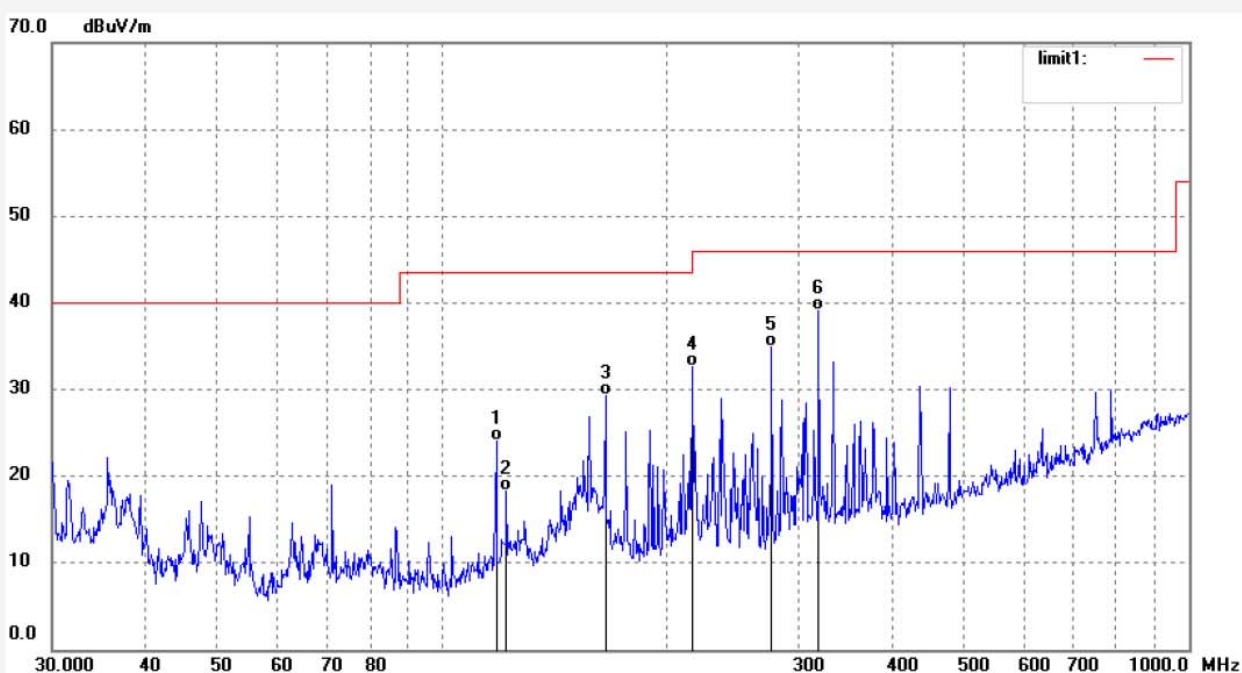

No.	Freq. (MHz)	Reading (dBuV/m)	Factor (dB)	Result (dBuV/m)	Limit (dBuV/m)	Margin (dB)	Detector	Height (cm)	Degree (deg.)	Remark
1	118.0956	51.45	-27.40	24.05	43.50	-19.45	QP	200	163	
2	121.8897	45.84	-27.49	18.35	43.50	-25.15	QP	200	211	
3	165.4713	55.74	-26.48	29.26	43.50	-14.24	QP	200	201	
4	216.1194	56.74	-24.05	32.69	46.00	-13.31	QP	200	96	
5	276.3817	57.17	-22.33	34.84	46.00	-11.16	QP	200	331	
6	319.2071	59.70	-20.65	39.05	46.00	-6.95	QP	200	218	



ACCURATE TECHNOLOGY CO., LTD.

F1,Bldg,A,Changyuan New Material Port Keyuan Rd,
Science & Industry Park,Nanshan Shenzhen,P.R.China

Site: 2# Chamber

Tel:+86-0755-26503290

Fax:+86-0755-26503396

Job No.: FRANK2019 #1369	Polarization: Vertical
Standard: FCC Class B 3M Radiated	Power Source: AC 120V/60Hz
Test item: Radiation Test	Date: 19/08/12/
Temp.(C)/Hum.(%) 25 C / 55 %	Time: 9/41/50
EUT: SMART WI-FI HUMIDIFIER	Engineer Signature:
Mode: TX 2437MHz	Distance: 3m
Model: MW3038	
Manufacturer: Guangdong Mixwell Technology Co.,Ltd.	

Note: Report NO.:ATE20191168

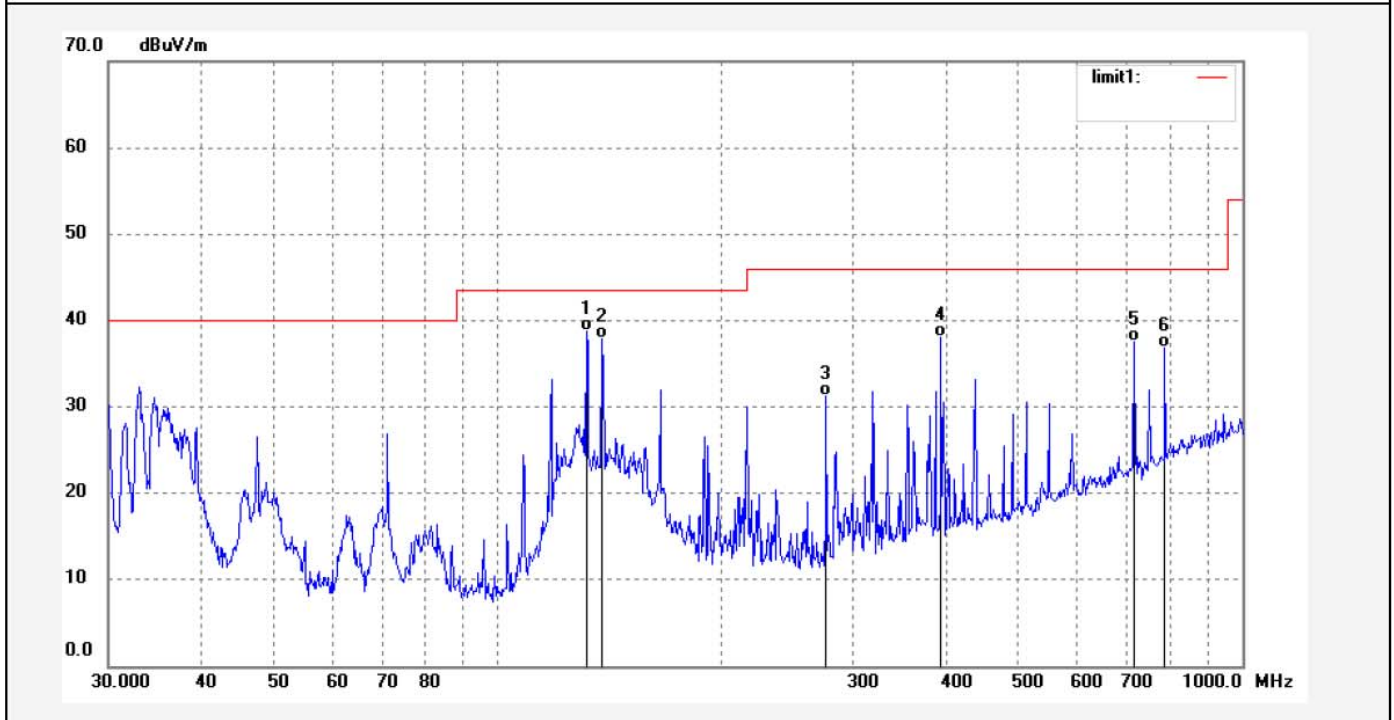

No.	Freq. (MHz)	Reading (dBuV/m)	Factor (dB)	Result (dBuV/m)	Limit (dBuV/m)	Margin (dB)	Detector	Height (cm)	Degree (deg.)	Remark
1	131.6853	66.51	-27.75	38.76	43.50	-4.74	QP	100	146	
2	138.3249	65.79	-27.91	37.88	43.50	-5.62	QP	100	330	
3	276.3817	53.58	-22.33	31.25	46.00	-14.75	QP	100	100	
4	394.1197	56.40	-18.41	37.99	46.00	-8.01	QP	100	359	
5	716.2038	48.70	-11.09	37.61	46.00	-8.39	QP	100	201	
6	787.4749	46.21	-9.33	36.88	46.00	-9.12	QP	100	179	

ACCURATE TECHNOLOGY CO., LTD.

 F1,Bldg,A,Changyuan New Material Port Keyuan Rd,
 Science & Industry Park,Nanshan Shenzhen,P.R.China

Site: 2# Chamber

Tel:+86-0755-26503290

Fax:+86-0755-26503396

Job No.: FRANK2019 #1371

Standard: FCC Class B 3M Radiated

Test item: Radiation Test

Temp.(C)/Hum.(%) 25 C / 55 %

EUT: SMART WI-FI HUMIDIFIER

Mode: TX 2462MHz

Model: MW3038

Manufacturer: Guangdong Mixwell Technology Co.,Ltd.

Polarization: Horizontal

Power Source: AC 120V/60Hz

Date: 19/08/12/

Time: 9/42/50

Engineer Signature:

Distance: 3m

Note: Report NO.:ATE20191168

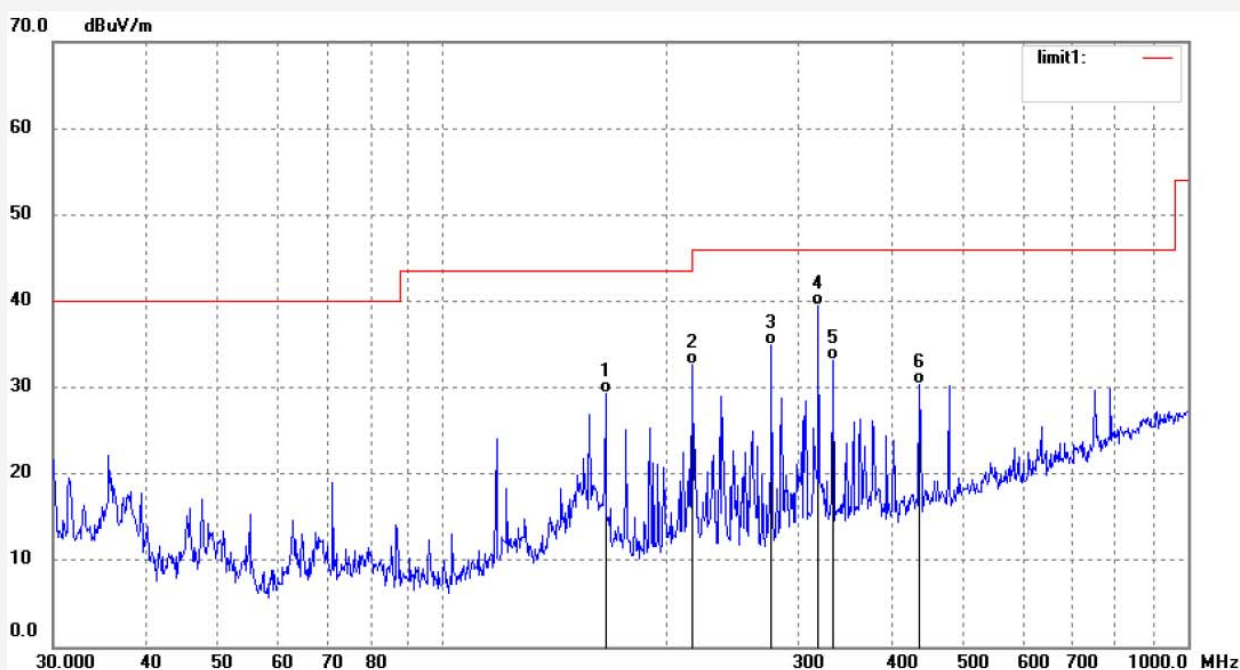

No.	Freq. (MHz)	Reading (dBuV/m)	Factor (dB)	Result (dBuV/m)	Limit (dBuV/m)	Margin (dB)	Detector	Height (cm)	Degree (deg.)	Remark
1	165.4713	55.74	-26.48	29.26	43.50	-14.24	QP	200	130	
2	216.1194	56.74	-24.05	32.69	46.00	-13.31	QP	200	212	
3	276.3817	57.17	-22.33	34.84	46.00	-11.16	QP	200	61	
4	319.2071	60.20	-20.65	39.55	46.00	-6.45	QP	200	115	
5	334.1254	53.09	-19.94	33.15	46.00	-12.85	QP	200	146	
6	436.3956	48.05	-17.60	30.45	46.00	-15.55	QP	200	63	

Job No.: FRANK2019 #1370

Standard: FCC Class B 3M Radiated

Test item: Radiation Test

Temp.(C)/Hum.(%) 25 C / 55 %

EUT: SMART WI-FI HUMIDIFIER

Mode: TX 2462MHz

Model: MW3038

Manufacturer: Guangdong Mixwell Technology Co.,Ltd.

Polarization: Vertical

Power Source: AC 120V/60Hz

Date: 19/08/12/

Time: 9/41/50

Engineer Signature:

Distance: 3m

Note: Report NO.:ATE20191168

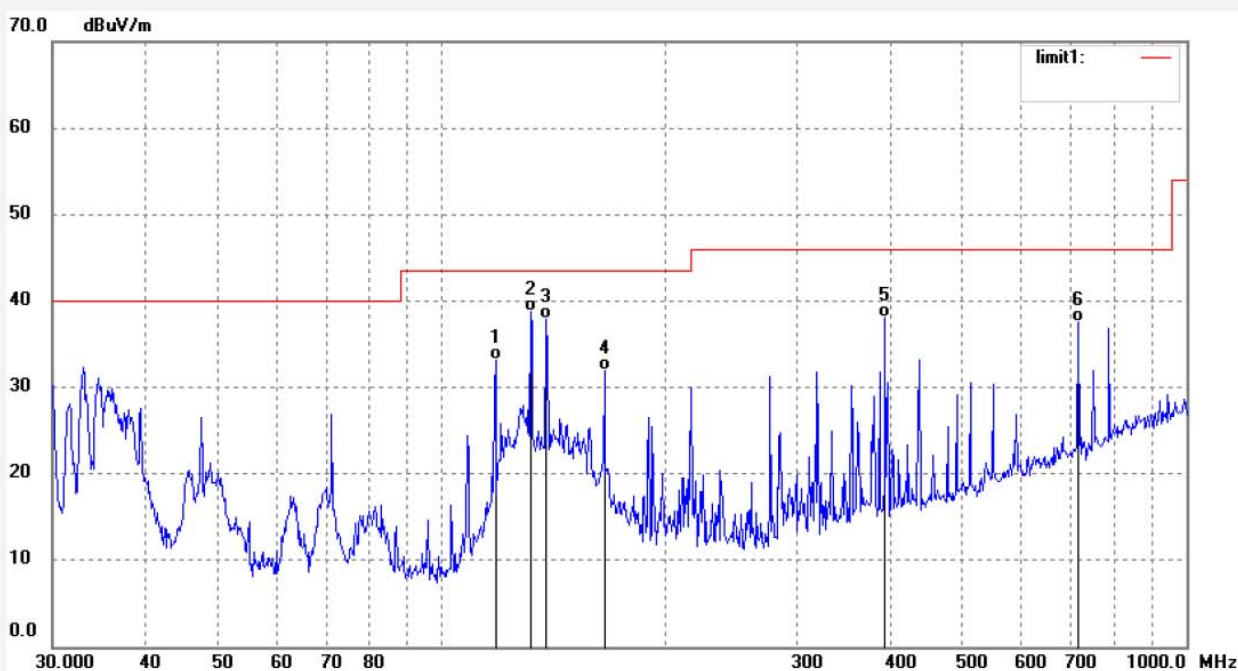

No.	Freq. (MHz)	Reading (dBuV/m)	Factor (dB)	Result (dBuV/m)	Limit (dBuV/m)	Margin (dB)	Detector	Height (cm)	Degree (deg.)	Remark
1	118.0956	60.51	-27.40	33.11	43.50	-10.39	QP	100	189	
2	131.6853	66.51	-27.75	38.76	43.50	-4.74	QP	100	55	
3	138.3249	65.79	-27.91	37.88	43.50	-5.62	QP	100	201	
4	165.4713	58.45	-26.48	31.97	43.50	-11.53	QP	100	311	
5	394.1197	56.40	-18.41	37.99	46.00	-8.01	QP	100	63	
6	716.2038	48.70	-11.09	37.61	46.00	-8.39	QP	100	212	

Above 1G



ACCURATE TECHNOLOGY CO., LTD.

F1,Bldg,A,Changyuan New Material Port Keyuan Rd,
Science & Industry Park,Nanshan Shenzhen,P.R.China

Site: 1# Chamber

Tel:+86-0755-26503290

Fax:+86-0755-26503396

Job No.: FRANK2019 #1386	Polarization: Horizontal
Standard: FCC PK	Power Source: AC 120V/60Hz
Test item: Radiation Test	Date: 19/08/12/
Temp.(C)/Hum.(%) 25 C / 55 %	Time: 9/22/09
EUT: SMART WI-FI HUMIDIFIER	Engineer Signature:
Mode: TX Channel 1(802.11B)	Distance: 3m
Model: MW3038	
Manufacturer: Guangdong Mixwell Technology Co.,Ltd	

Note: Report NO.:ATE20191168

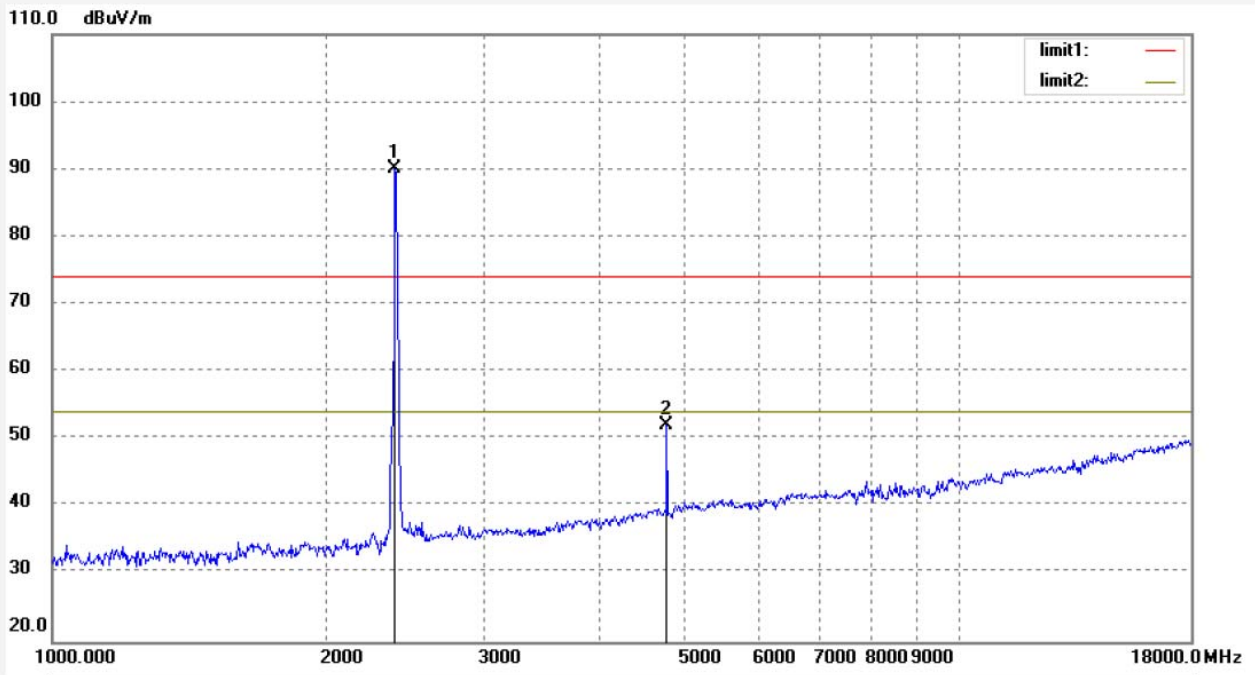

No.	Freq. (MHz)	Reading (dBuV/m)	Factor (dB)	Result (dBuV/m)	Limit (dBuV/m)	Margin (dB)	Detector	Height (cm)	Degree (deg.)	Remark
1	2412.259	96.31	-6.33	89.98			peak	200	323	
2	4824.584	51.21	0.82	52.03	74.00	-21.97	peak	200	106	

Note: The fundamental radiated emissions were reduced by Band Reject Filter in the plot.

Job No.: FRANK2019 #1387

Standard: FCC PK

Test item: Radiation Test

Temp.(C)/Hum.(%) 25 C / 55 %

EUT: SMART WI-FI HUMIDIFIER

Mode: TX Channel 1(802.11B)

Model: MW3038

Manufacturer: Guangdong Mixwell Technology Co.,Ltd

Polarization: Vertical

Power Source: AC 120V/60Hz

Date: 19/08/12/

Time: 9/23/17

Engineer Signature:

Distance: 3m

Note: Report NO.:ATE20191168

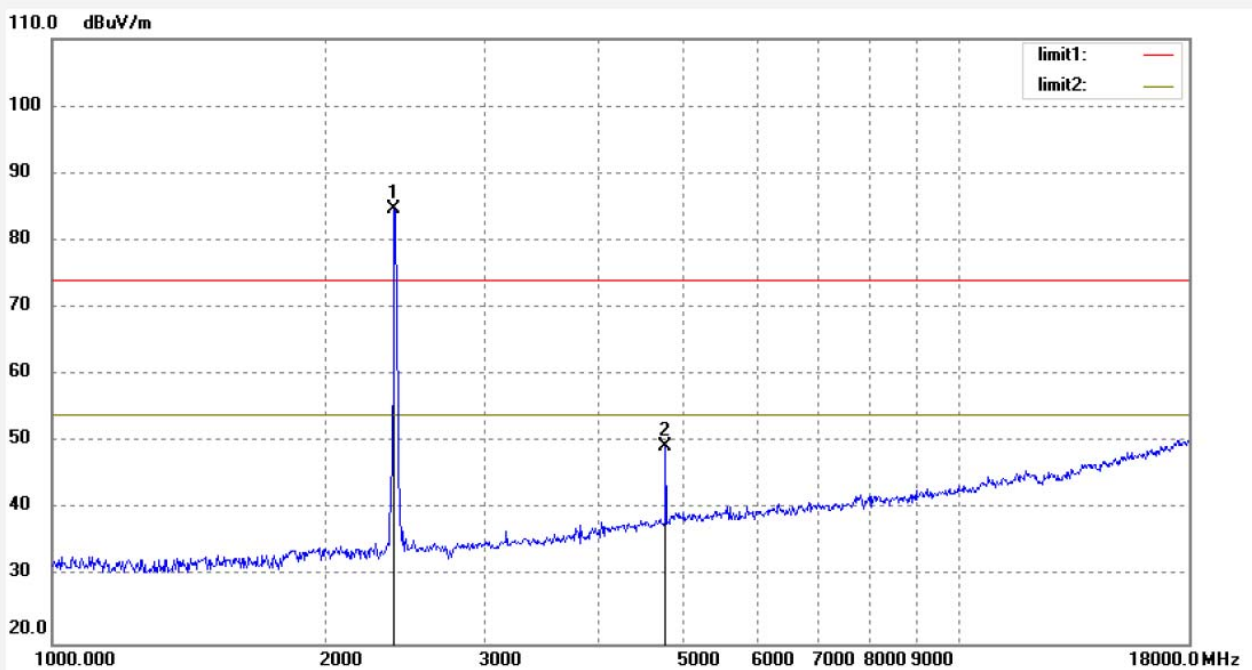

No.	Freq. (MHz)	Reading (dBuV/m)	Factor (dB)	Result (dBuV/m)	Limit (dBuV/m)	Margin (dB)	Detector	Height (cm)	Degree (deg.)	Remark
1	2412.259	91.13	-6.33	84.80			peak	150	221	
2	4824.584	48.56	0.82	49.38	74.00	-24.62	peak	150	163	

Note: The fundamental radiated emissions were reduced by Band Reject Filter in the plot.

Job No.: FRANK2019 #1389

Standard: FCC PK

Test item: Radiation Test

Temp.(C)/Hum.(%) 25 C / 55 %

EUT: SMART WI-FI HUMIDIFIER

Mode: TX Channel 6(802.11B)

Model: MW3038

Manufacturer: Guangdong Mixwell Technology Co.,Ltd

Polarization: Horizontal

Power Source: AC 120V/60Hz

Date: 19/08/12/

Time: 9/26/24

Engineer Signature:

Distance: 3m

Note: Report NO.:ATE20191168

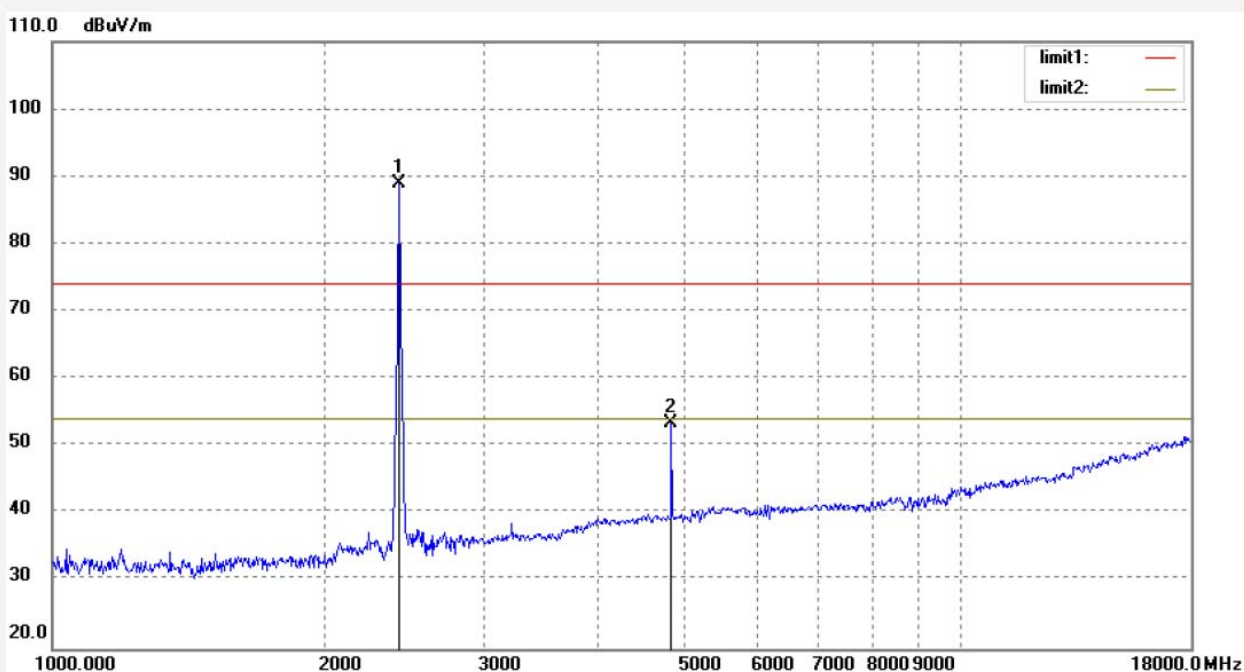

No.	Freq. (MHz)	Reading (dBuV/m)	Factor (dB)	Result (dBuV/m)	Limit (dBuV/m)	Margin (dB)	Detector	Height (cm)	Degree (deg.)	Remark
1	2437.200	95.28	-6.24	89.04			peak	200	52	
2	4874.424	52.32	1.07	53.39	74.00	-20.61	peak	200	103	

Note: The fundamental radiated emissions were reduced by Band Reject Filter in the plot.

Job No.: FRANK2019 #1388	Polarization: Vertical
Standard: FCC PK	Power Source: AC 120V/60Hz
Test item: Radiation Test	Date: 19/08/12/
Temp.(C)/Hum.(%) 25 C / 55 %	Time: 9/25/06
EUT: SMART WI-FI HUMIDIFIER	Engineer Signature:
Mode: TX Channel 6(802.11B)	Distance: 3m
Model: MW3038	
Manufacturer: Guangdong Mixwell Technology Co.,Ltd	

Note: Report NO.:ATE20191168

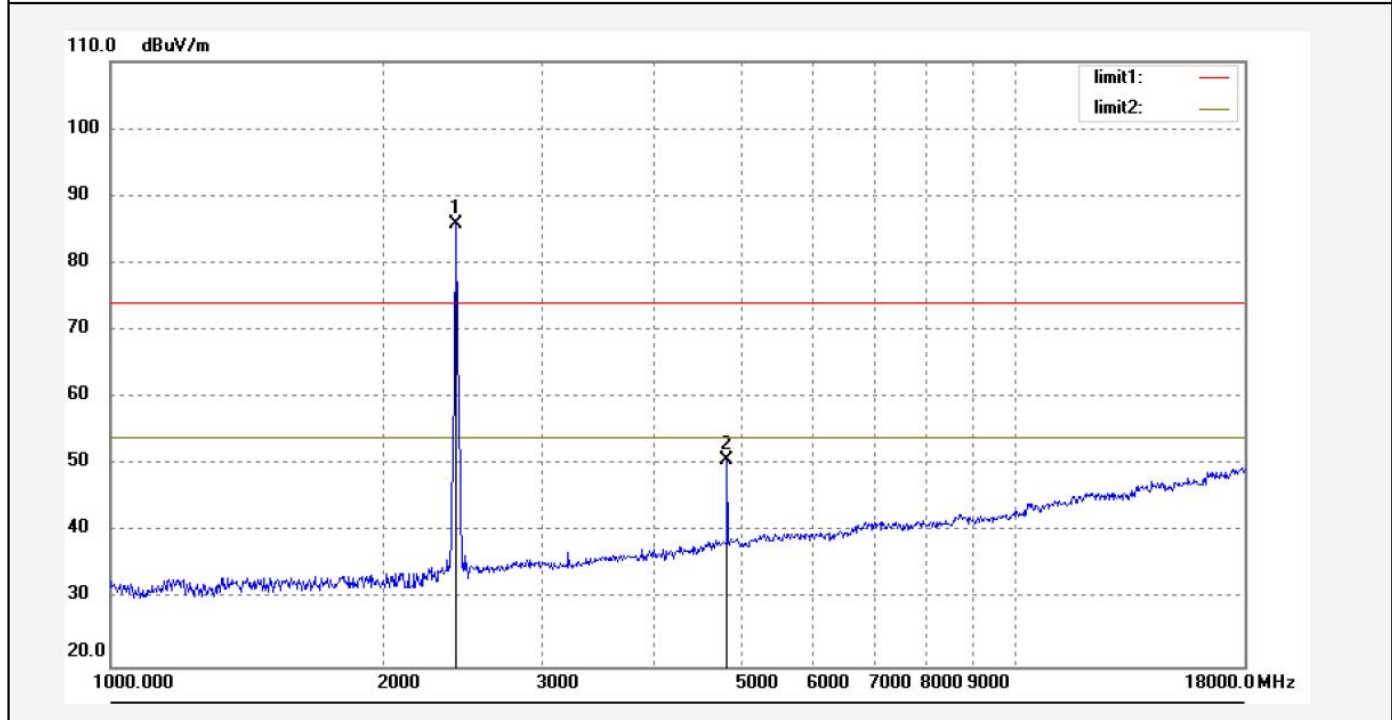

No.	Freq. (MHz)	Reading (dBuV/m)	Factor (dB)	Result (dBuV/m)	Limit (dBuV/m)	Margin (dB)	Detector	Height (cm)	Degree (deg.)	Remark
1	2437.221	92.05	-6.20	85.85			peak	150	331	
2	4874.424	49.60	1.07	50.67	74.00	-23.33	peak	150	169	

Note: The fundamental radiated emissions were reduced by Band Reject Filter in the plot.

ACCURATE TECHNOLOGY CO., LTD.

 F1,Bldg,A,Changyuan New Material Port Keyuan Rd,
 Science & Industry Park,Nanshan Shenzhen,P.R.China

Site: 1# Chamber

Tel:+86-0755-26503290

Fax:+86-0755-26503396

Job No.: FRANK2019 #1390

Standard: FCC PK

Test item: Radiation Test

Temp.(C)/Hum.(%) 25 C / 55 %

EUT: SMART WI-FI HUMIDIFIER

Mode: TX Channel 11(802.11B)

Model: MW3038

Manufacturer: Guangdong Mixwell Technology Co.,Ltd

Polarization: Horizontal

Power Source: AC 120V/60Hz

Date: 19/08/12/

Time: 9/27/55

Engineer Signature:

Distance: 3m

Note: Report NO.:ATE20191168

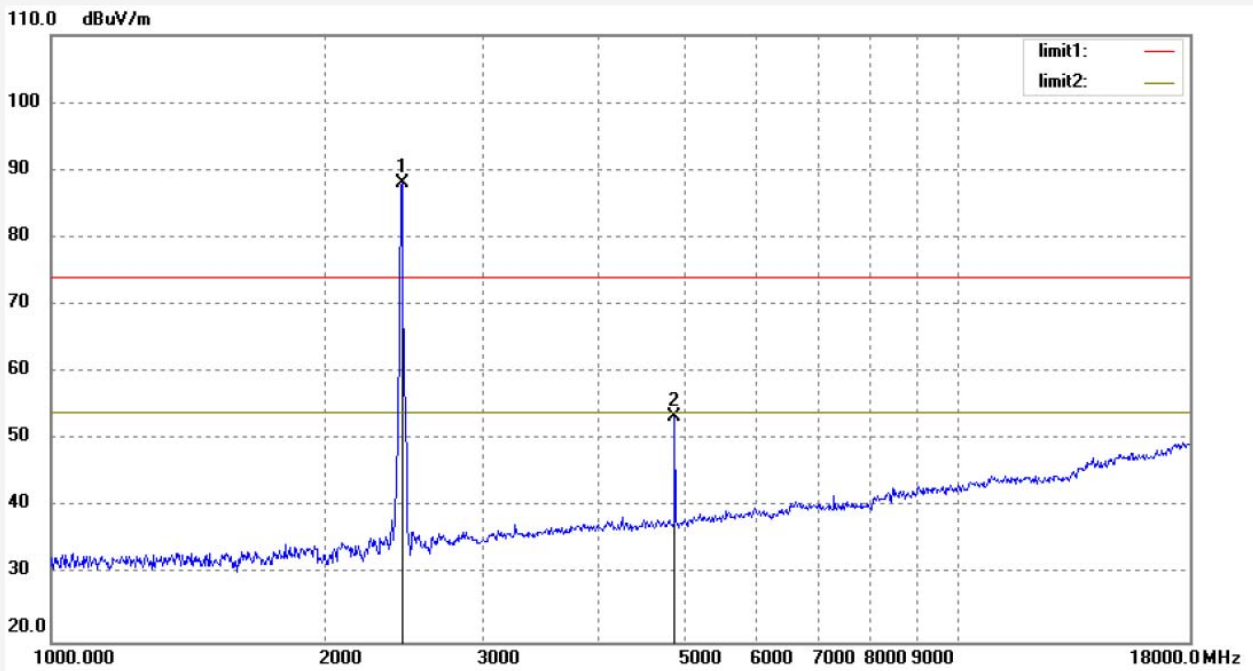

No.	Freq. (MHz)	Reading (dBuV/m)	Factor (dB)	Result (dBuV/m)	Limit (dBuV/m)	Margin (dB)	Detector	Height (cm)	Degree (deg.)	Remark
1	2462.307	94.21	-6.10	88.11			peak	200	336	
2	4924.717	52.06	1.32	53.38	74.00	-20.62	peak	200	106	

Note: The fundamental radiated emissions were reduced by Band Reject Filter in the plot.

Job No.: FRANK2019 #1391

Standard: FCC PK

Test item: Radiation Test

Temp.(C)/Hum.(%) 25 C / 55 %

EUT: SMART WI-FI HUMIDIFIER

Mode: TX Channel 11(802.11B)

Model: MW3038

Manufacturer: Guangdong Mixwell Technology Co.,Ltd

Polarization: Vertical

Power Source: AC 120V/60Hz

Date: 19/08/12/

Time: 9/29/13

Engineer Signature:

Distance: 3m

Note: Report NO.:ATE20191168

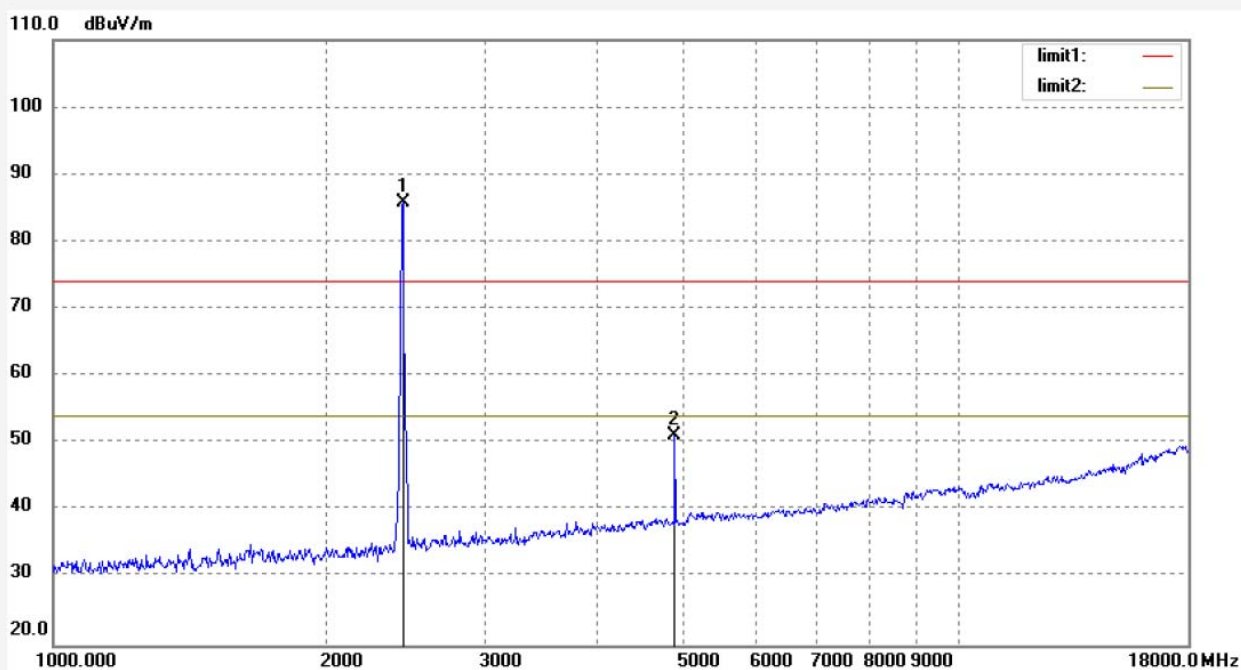

No.	Freq. (MHz)	Reading (dBuV/m)	Factor (dB)	Result (dBuV/m)	Limit (dBuV/m)	Margin (dB)	Detector	Height (cm)	Degree (deg.)	Remark
1	2462.307	91.99	-6.10	85.89			peak	150	66	
2	4924.717	49.86	1.32	51.18	74.00	-22.82	peak	150	189	

Note: The fundamental radiated emissions were reduced by Band Reject Filter in the plot.

11. BAND EDGE COMPLIANCE TEST

11.1. Block Diagram of Test Setup

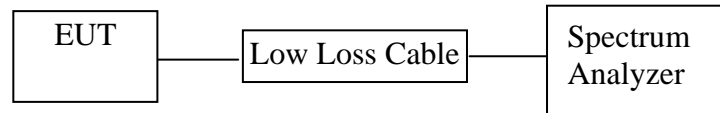

11.2. The Requirement For Section 15.247(d)

Section 15.247(d): In any 100 kHz bandwidth outside the frequency band in which the spread spectrum or digitally modulated intentional radiator is operating, the radio frequency power that is produced by the intentional radiator shall be at least 20 dB below that in the 100 kHz bandwidth within the band that contains the highest level of the desired power, based on either an RF conducted or a radiated measurement, provided the transmitter demonstrates compliance with the peak conducted power limits. If the transmitter complies with the conducted power limits based on the use of RMS averaging over a time interval, as permitted under paragraph (b)(3) of this section, the attenuation required under this paragraph shall be 30 dB instead of 20 dB. Attenuation below the general limits specified in Section 15.209(a) is not required. In addition, radiated emissions which fall in the restricted bands, as defined in Section 15.205(a), must also comply with the radiated emission limits specified in Section 15.209(a).

11.3. EUT Configuration on Measurement

The equipment are installed on the emission Measurement to meet the commission requirements and operating regulations in a manner which tends to maximize its emission characteristics in normal application.

11.4. Operating Condition of EUT

11.4.1. Setup the EUT and simulator as shown as Section 11.1.

11.4.2. Turn on the power of all equipment.

11.4.3. Let the EUT work in TX modes measure it. The transmit frequency are 2412-2462MHz. We select 2412MHz and 2462MHz TX frequency to transmit.

11.5. Test Procedure

Conducted Band Edge:

11.5.1. The transmitter output was connected to the spectrum analyzer via a low loss cable.

11.5.2. Set RBW of spectrum analyzer to 100kHz and VBW to 300kHz.

Radiate Band Edge:

11.5.3. The EUT is placed on a turntable, which is 1.5m above the ground plane and worked at highest radiated power.

11.5.4. The turntable was rotated for 360 degrees to determine the position of maximum emission level.

11.5.5. EUT is set 3m away from the receiving antenna, which is varied from 1m to 4m to find out the highest emission.

11.5.6. Set the spectrum analyzer in the following setting in order to capture the lower and upper band-edges of the emission:

11.5.7. RBW=1MHz, VBW=1MHz

11.5.8. The band edges was measured and recorded.

11.6. Test Result

The test was performed with 802.11b		
Frequency (MHz)	Result of Band Edge (dBc)	Limit of Band Edge (dBc)
2400.0	40.06	> 20dBc
2497.1	42.05	> 20dBc

The test was performed with 802.11g		
Frequency (MHz)	Result of Band Edge (dBc)	Limit of Band Edge (dBc)
2400.0	29.05	> 20dBc
2483.5	33.82	> 20dBc

The test was performed with 802.11n (20MHz)		
Frequency (MHz)	Result of Band Edge (dBc)	Limit of Band Edge (dBc)
2400.0	30.13	> 20dBc
2483.5	34.51	> 20dBc

802.11b Low Channel 2412MHz

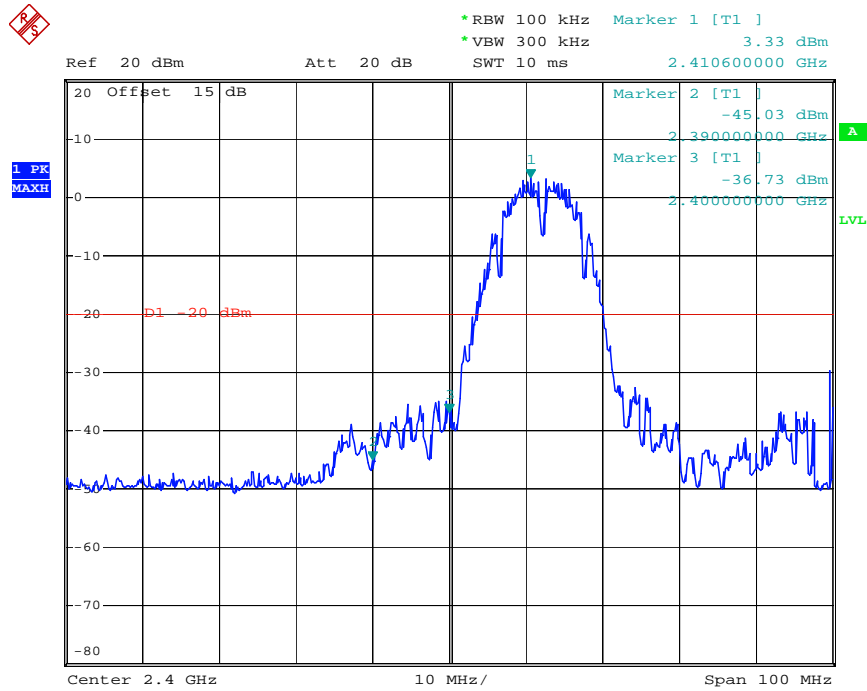

Date: 6.AUG.2019 13:30:47

802.11b High Channel 2462MHz

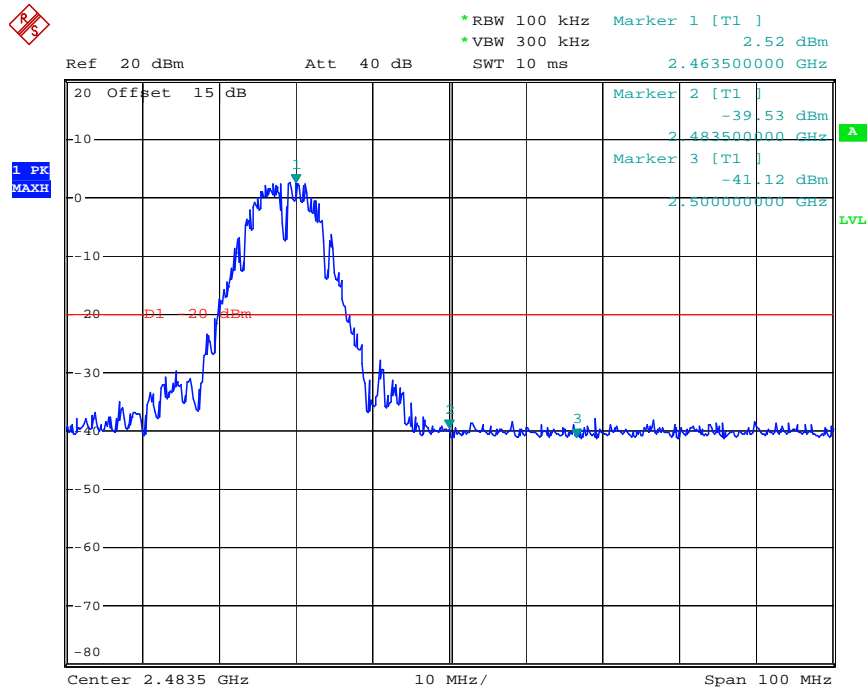

Date: 6.AUG.2019 13:33:11

802.11g Low Channel 2412MHz

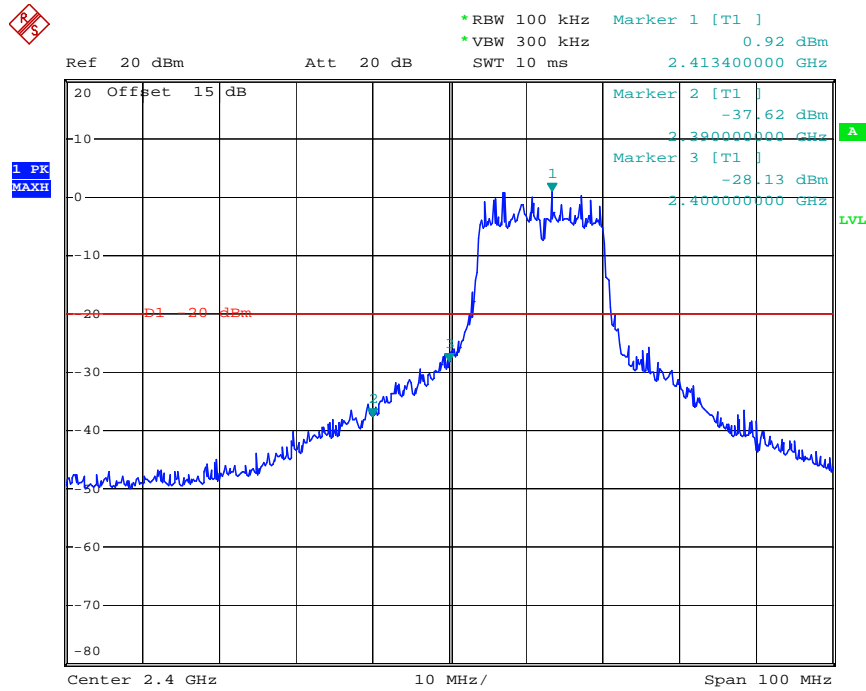

Date: 6.AUG.2019 13:31:15

802.11g High Channel 2462MHz

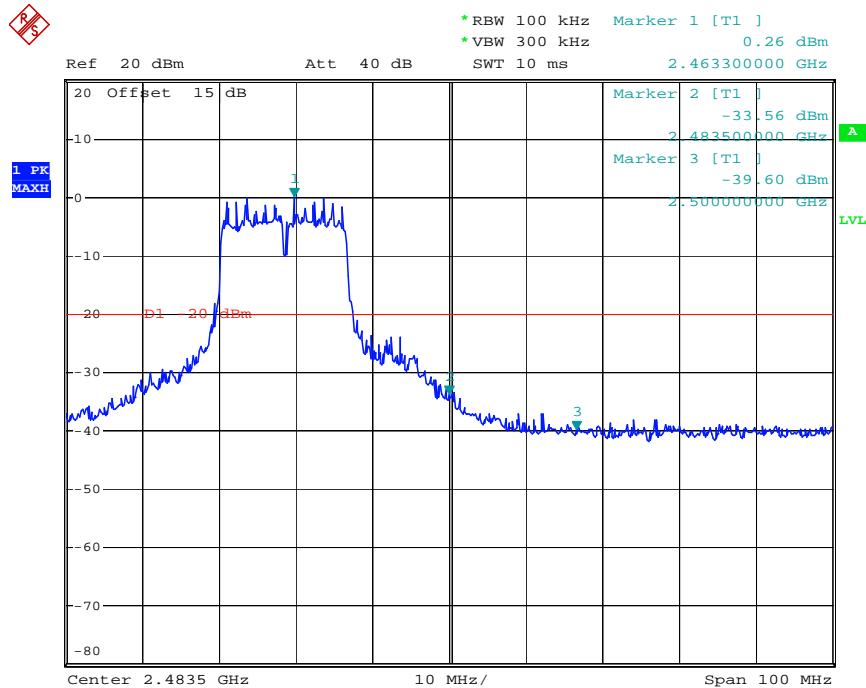

Date: 6.AUG.2019 13:32:43

802.11n(20MHz) Low Channel 2412MHz

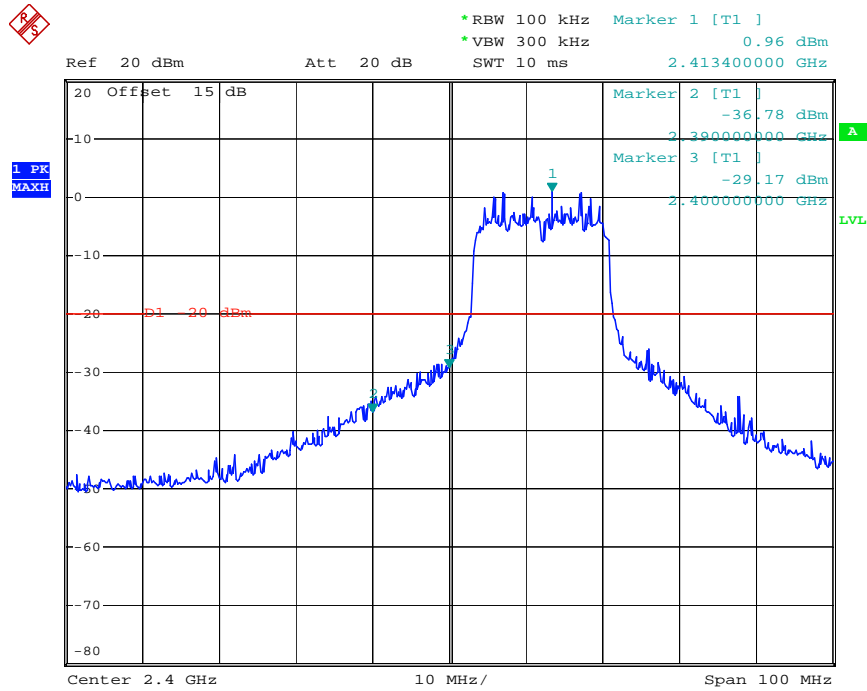

Date: 6.AUG.2019 13:31:38

802.11n(20MHz) High Channel 2462MHz

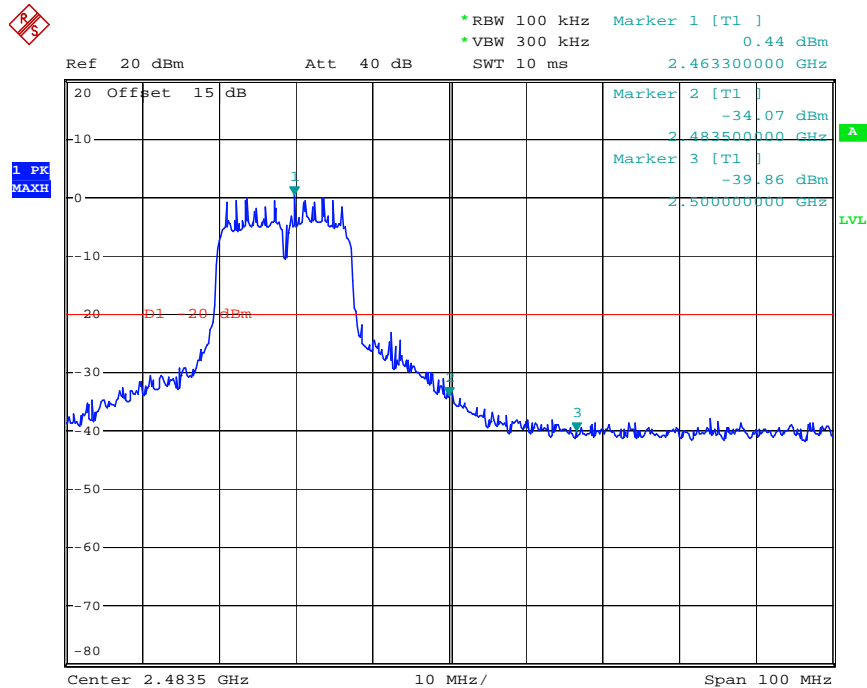

Date: 6.AUG.2019 13:32:17

Radiated Band Edge Result

Note:

1. Emissions attenuated more than 20 dB below the permissible value are not reported.
2. The field strength is calculated by adding the antenna factor, high pass filter loss(if used) and cable loss, and subtracting the amplifier gain(if any)from the measured reading. The basic equation calculation is as follows:
$$\text{Result} = \text{Reading} + \text{Corrected Factor}$$
3. Display the measurement of peak values.
4. The EUT is tested radiation emission at each test mode (802.11b/g/n) in three axes. The worst emissions are reflected in the following plots.
5. The average measurement was not performed when peak measured data under the limit of average detection.

Job No.: FRANK2019 #192

Standard: FCC PK

Test item: Radiation Test

Temp.(C)/Hum.(%) 25 C / 55 %

EUT: SMART WI-FI HUMIDIFIER

Mode: TX Channel 1(802.11B)

Model: MW3038

Manufacturer: Guangdong Mixwell Technology Co.,Ltd.

Polarization: Horizontal

Power Source: AC 120V/60Hz

Date: 19/08/12/

Time: 15/57/44

Engineer Signature:

Distance: 3m

Note: Report NO.:ATE20191168

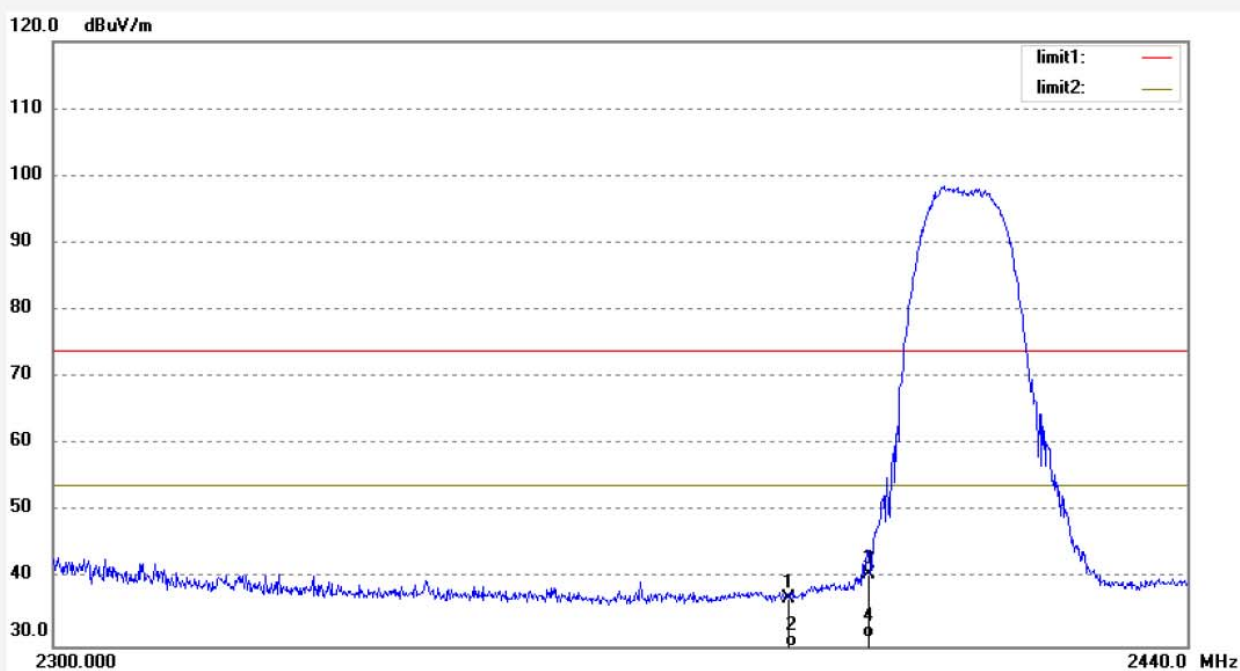

No.	Freq. (MHz)	Reading (dBuV/m)	Factor (dB)	Result (dBuV/m)	Limit (dBuV/m)	Margin (dB)	Detector	Height (cm)	Degree (deg.)	Remark
1	2390.000	41.50	-4.32	37.18	74.00	-36.82	peak	250	128	
2	2390.000	32.35	-4.32	28.03	54.00	-25.97	AVG	250	132	
3	2400.000	44.93	-4.27	40.66	74.00	-33.34	peak	250	109	
4	2400.000	35.46	-4.27	31.19	54.00	-22.81	AVG	250	84	

Job No.: FRANK2019 #193

Standard: FCC PK

Test item: Radiation Test

Temp.(C)/Hum.(%) 25 C / 55 %

EUT: SMART WI-FI HUMIDIFIER

Mode: TX Channel 1(802.11B)

Model: MW3038

Manufacturer: Guangdong Mixwell Technology Co.,Ltd.

Polarization: Vertical

Power Source: AC 120V/60Hz

Date: 19/08/12/

Time: 15/58/35

Engineer Signature:

Distance: 3m

Note: Report NO.:ATE20191168

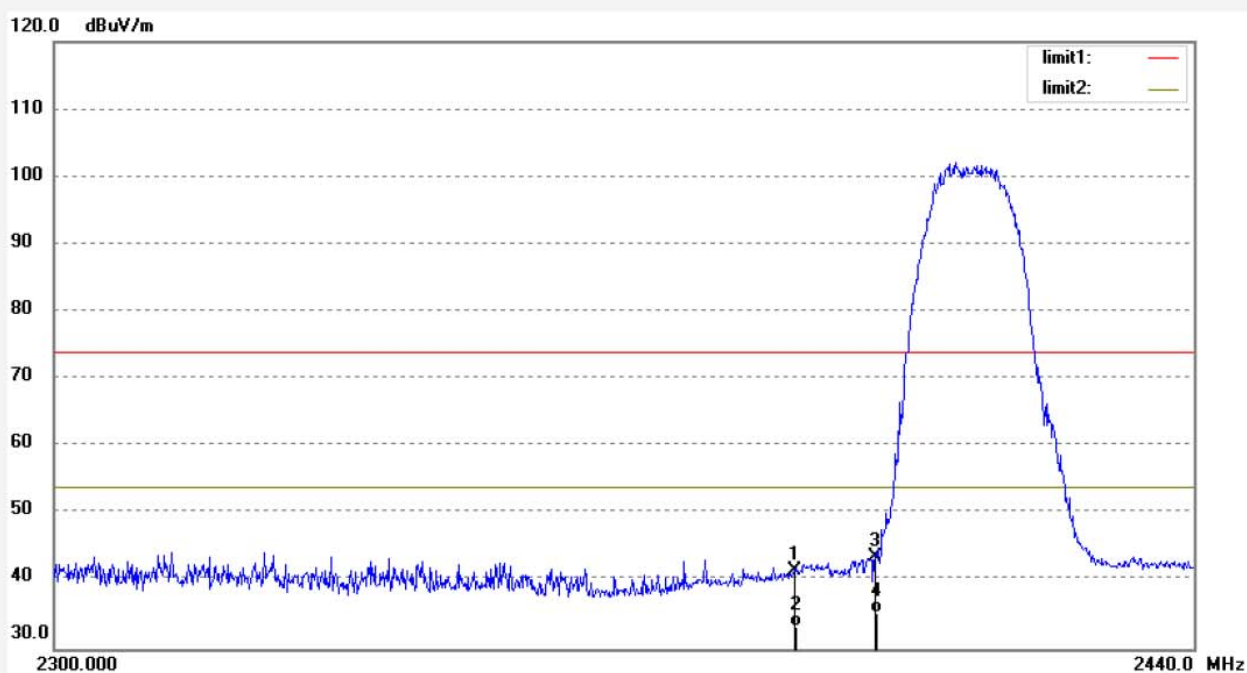

No.	Freq. (MHz)	Reading (dBuV/m)	Factor (dB)	Result (dBuV/m)	Limit (dBuV/m)	Margin (dB)	Detector	Height (cm)	Degree (deg.)	Remark
1	2390.000	45.87	-4.32	41.55	74.00	-32.45	peak	250	195	
2	2390.000	37.64	-4.32	33.32	54.00	-20.68	AVG	200	121	
3	2400.000	47.90	-4.27	43.63	74.00	-30.37	peak	200	230	
4	2400.000	39.45	-4.27	35.18	54.00	-18.82	AVG	200	187	

Job No.: FRANK2019 #207

Standard: FCC PK

Test item: Radiation Test

Temp.(C)/Hum.(%) 25 C / 55 %

EUT: SMART WI-FI HUMIDIFIER

Mode: TX Channel 11(802.11B)

Model: MW3038

Manufacturer: Guangdong Mixwell Technology Co.,Ltd.

Polarization: Horizontal

Power Source: AC 120V/60Hz

Date: 19/08/12/

Time: 16/18/49

Engineer Signature:

Distance: 3m

Note: Report NO.:ATE20191168

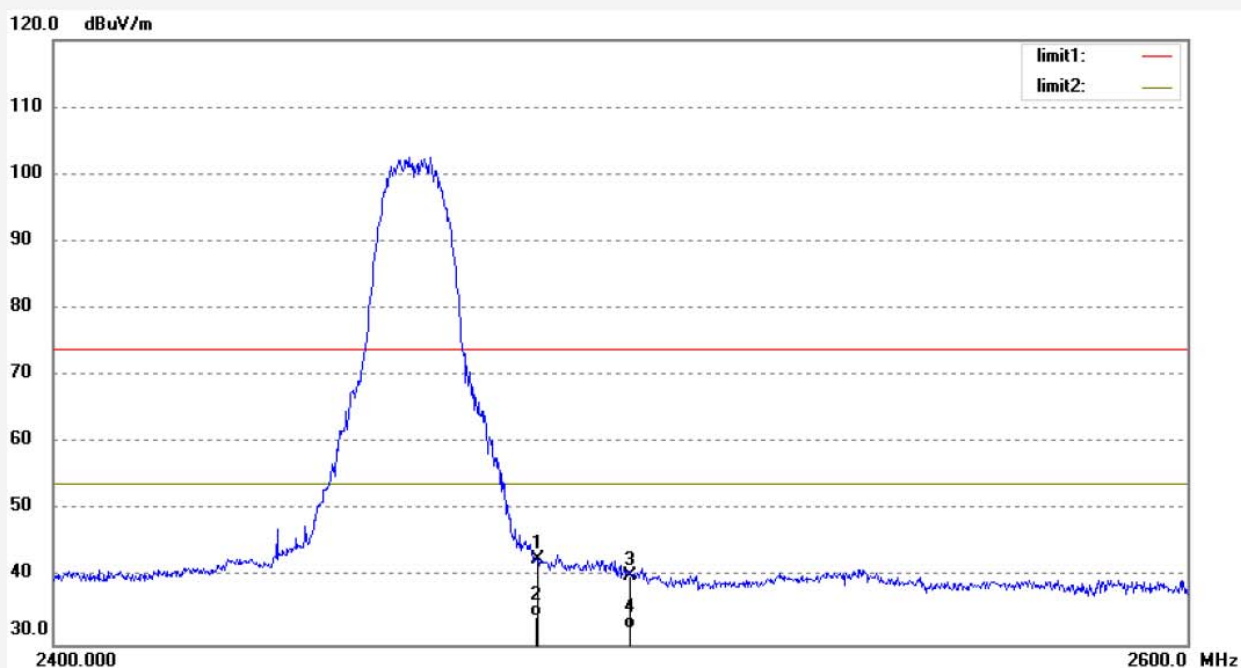

No.	Freq. (MHz)	Reading (dBuV/m)	Factor (dB)	Result (dBuV/m)	Limit (dBuV/m)	Margin (dB)	Detector	Height (cm)	Degree (deg.)	Remark
1	2483.500	46.52	-3.89	42.63	74.00	-31.37	peak	300	199	
2	2483.500	38.16	-3.89	34.27	54.00	-19.73	AVG	250	264	
3	2500.000	44.07	-3.81	40.26	74.00	-33.74	peak	250	162	
4	2500.000	36.20	-3.81	32.39	54.00	-21.61	AVG	250	102	

Job No.: FRANK2019 #206

Standard: FCC PK

Test item: Radiation Test

Temp.(C)/Hum.(%) 25 C / 55 %

EUT: SMART WI-FI HUMIDIFIER

Mode: TX Channel 11(802.11B)

Model: MW3038

Manufacturer: Guangdong Mixwell Technology Co.,Ltd.

Polarization: Vertical

Power Source: AC 120V/60Hz

Date: 19/08/12/

Time: 16/18/07

Engineer Signature:

Distance: 3m

Note: Report NO.:ATE20191168

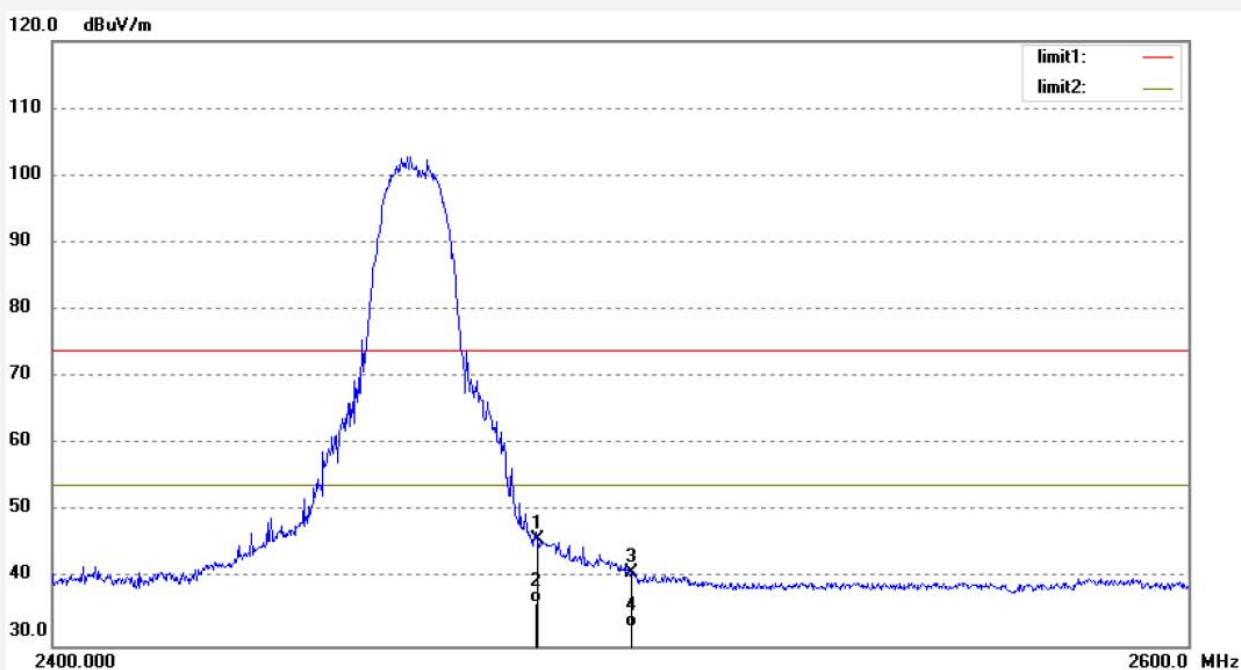

No.	Freq. (MHz)	Reading (dBuV/m)	Factor (dB)	Result (dBuV/m)	Limit (dBuV/m)	Margin (dB)	Detector	Height (cm)	Degree (deg.)	Remark
1	2483.500	49.71	-3.89	45.82	74.00	-28.18	peak	250	163	
2	2483.500	40.26	-3.89	36.37	54.00	-17.63	AVG	150	25	
3	2500.000	44.68	-3.81	40.87	74.00	-33.13	peak	250	232	
4	2500.000	36.69	-3.81	32.88	54.00	-21.12	AVG	150	196	



ACCURATE TECHNOLOGY CO., LTD.

F1,Bldg,A,Changyuan New Material Port Keyuan Rd,
Science & Industry Park,Nanshan Shenzhen,P.R.China

Site: 1# Chamber

Tel:+86-0755-26503290

Fax:+86-0755-26503396

Job No.: FRANK2019 #195
 Standard: FCC PK
 Test item: Radiation Test
 Temp.(C)/Hum.(%) 25 C / 55 %
 EUT: SMART WI-FI HUMIDIFIER
 Mode: TX Channel 1(802.11G)
 Model: MW3038
 Manufacturer: Guangdong Mixwell Technology Co.,Ltd.

Polarization: Horizontal
 Power Source: AC 120V/60Hz
 Date: 19/08/12/
 Time: 16/00/42
 Engineer Signature:
 Distance: 3m

Note: Report NO.:ATE20191168

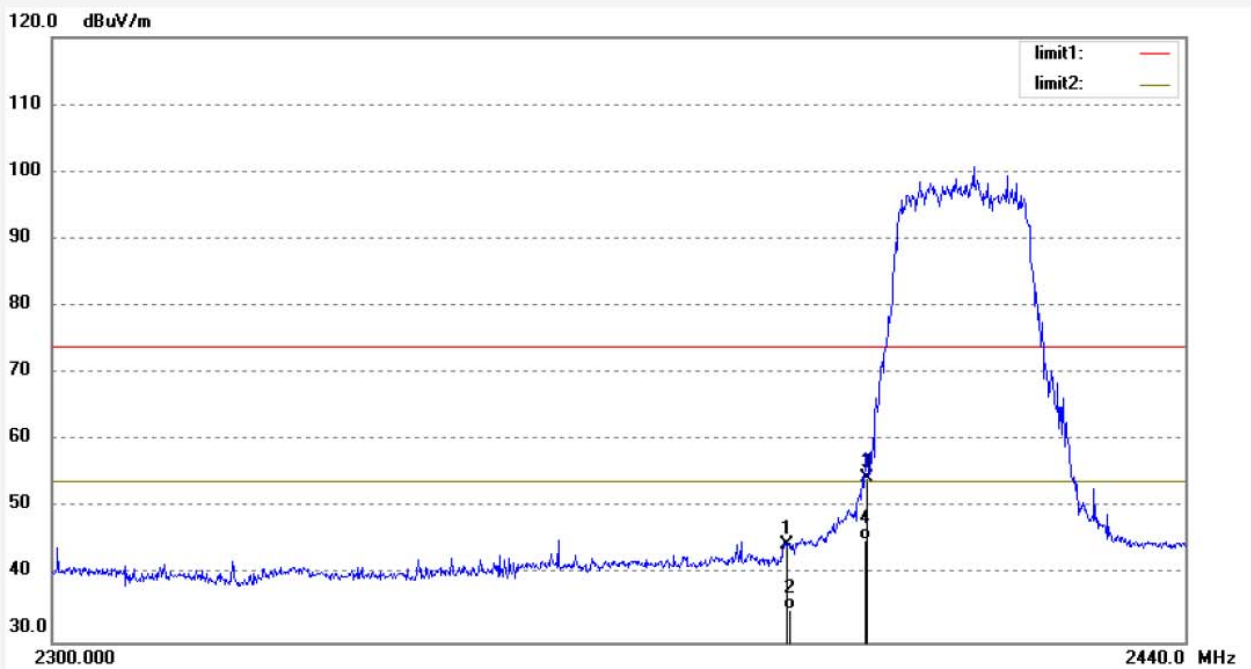

No.	Freq. (MHz)	Reading (dBuV/m)	Factor (dB)	Result (dBuV/m)	Limit (dBuV/m)	Margin (dB)	Detector	Height (cm)	Degree (deg.)	Remark
1	2390.000	48.81	-4.32	44.49	74.00	-29.51	peak	250	130	
2	2390.000	39.16	-4.32	34.84	54.00	-19.16	AVG	250	210	
3	2400.000	58.70	-4.27	54.43	74.00	-19.57	peak	250	95	
4	2400.000	49.56	-4.27	45.29	54.00	-8.71	AVG	250	64	

Job No.: FRANK2019 #194

Standard: FCC PK

Test item: Radiation Test

Temp.(C)/Hum.(%) 25 C / 55 %

EUT: SMART WI-FI HUMIDIFIER

Mode: TX Channel 1(802.11G)

Model: MW3038

Manufacturer: Guangdong Mixwell Technology Co.,Ltd.

Polarization: Vertical

Power Source: AC 120V/60Hz

Date: 19/08/12/

Time: 15/59/57

Engineer Signature:

Distance: 3m

Note: Report NO.:ATE20191168

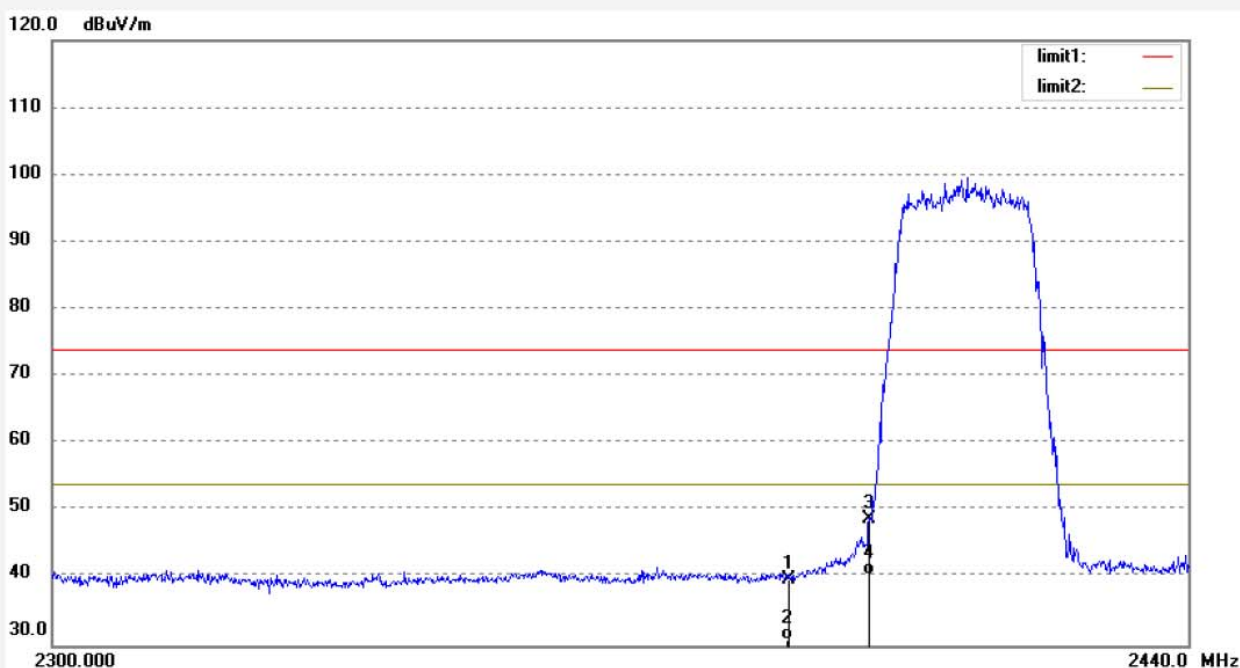

No.	Freq. (MHz)	Reading (dBuV/m)	Factor (dB)	Result (dBuV/m)	Limit (dBuV/m)	Margin (dB)	Detector	Height (cm)	Degree (deg.)	Remark
1	2390.000	44.12	-4.32	39.80	74.00	-34.20	peak	250	149	
2	2390.000	35.15	-4.32	30.83	54.00	-23.17	AVG	200	126	
3	2400.000	53.11	-4.27	48.84	74.00	-25.16	peak	250	94	
4	2400.000	44.64	-4.27	40.37	54.00	-13.63	AVG	250	50	

Job No.: FRANK2019 #204

Standard: FCC PK

Test item: Radiation Test

Temp.(C)/Hum.(%) 25 C / 55 %

EUT: SMART WI-FI HUMIDIFIER

Mode: TX Channel 11(802.11G)

Model: MW3038

Manufacturer: Guangdong Mixwell Technology Co.,Ltd.

Polarization: Horizontal

Power Source: AC 120V/60Hz

Date: 19/08/12/

Time: 16/16/16

Engineer Signature:

Distance: 3m

Note: Report NO.:ATE20191168

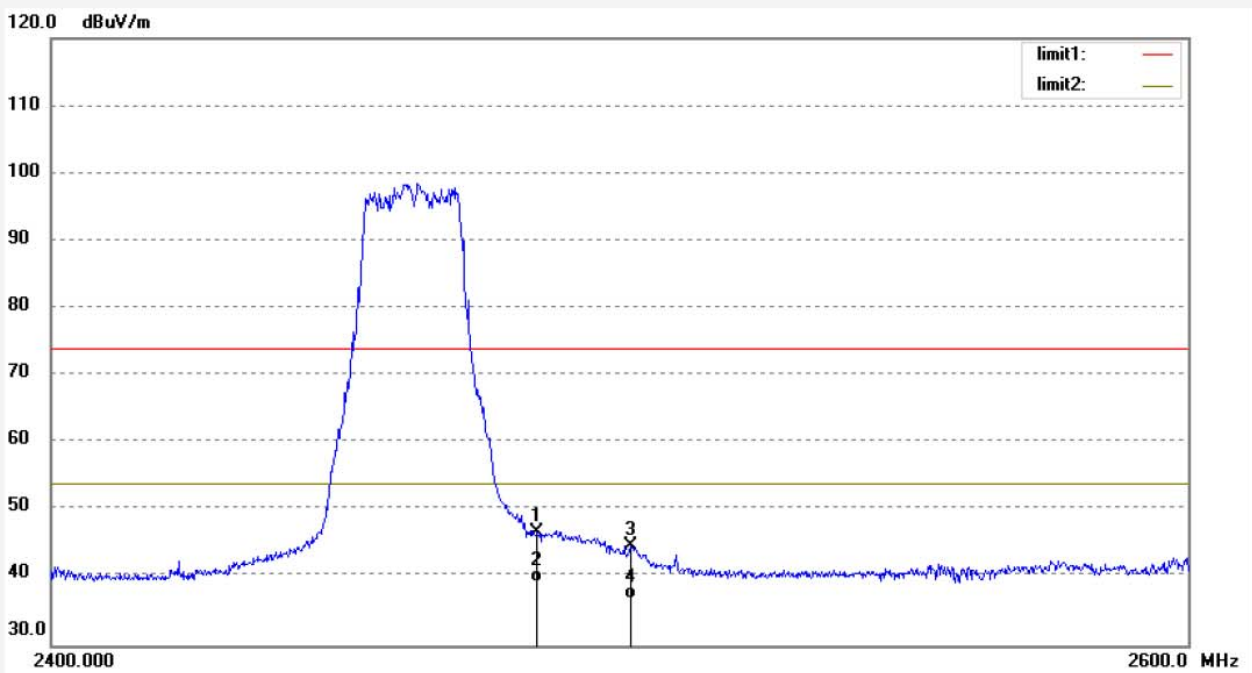

No.	Freq. (MHz)	Reading (dBuV/m)	Factor (dB)	Result (dBuV/m)	Limit (dBuV/m)	Margin (dB)	Detector	Height (cm)	Degree (deg.)	Remark
1	2483.500	50.73	-3.89	46.84	74.00	-27.16	peak	250	199	
2	2483.500	43.19	-3.89	39.30	54.00	-14.70	AVG	250	114	
3	2500.000	48.44	-3.81	44.63	74.00	-29.37	peak	250	62	
4	2500.000	40.69	-3.81	36.88	54.00	-17.12	AVG	250	160	

Job No.: FRANK2019 #205

Standard: FCC PK

Test item: Radiation Test

Temp.(C)/Hum.(%) 25 C / 55 %

EUT: SMART WI-FI HUMIDIFIER

Mode: TX Channel 11(802.11G)

Model: MW3038

Manufacturer: Guangdong Mixwell Technology Co.,Ltd.

Polarization: Vertical

Power Source: AC 120V/60Hz

Date: 19/08/12/

Time: 16/17/05

Engineer Signature:

Distance: 3m

Note: Report NO.:ATE20191168

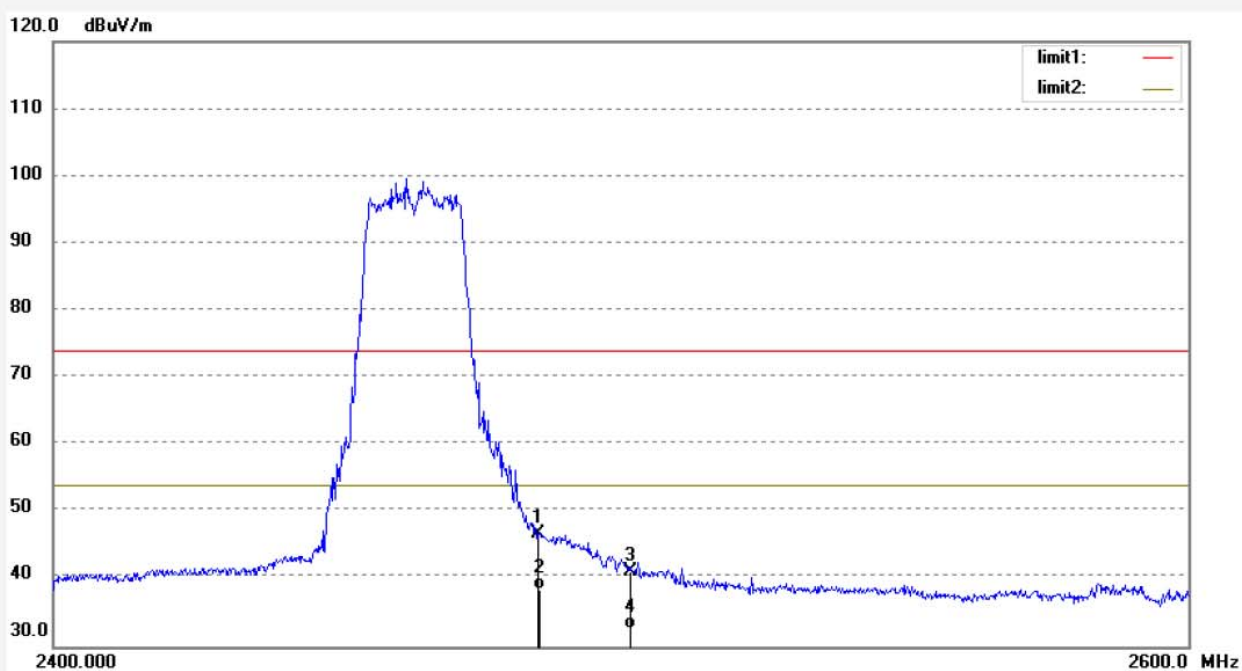

No.	Freq. (MHz)	Reading (dBuV/m)	Factor (dB)	Result (dBuV/m)	Limit (dBuV/m)	Margin (dB)	Detector	Height (cm)	Degree (deg.)	Remark
1	2483.500	50.61	-3.89	46.72	74.00	-27.28	peak	200	123	
2	2483.500	42.44	-3.89	38.55	54.00	-15.45	AVG	150	29	
3	2500.000	44.95	-3.81	41.14	74.00	-32.86	peak	250	61	
4	2500.000	36.49	-3.81	32.68	54.00	-21.32	AVG	150	160	

Job No.: FRANK2019 #196

Standard: FCC PK

Test item: Radiation Test

Temp.(C)/Hum.(%) 25 C / 55 %

EUT: SMART WI-FI HUMIDIFIER

Mode: TX Channel 1(802.11N20)

Model: MW3038

Manufacturer: Guangdong Mixwell Technology Co.,Ltd.

Polarization: Horizontal

Power Source: AC 120V/60Hz

Date: 19/08/12/

Time: 16/02/35

Engineer Signature:

Distance: 3m

Note: Report NO.:ATE20191168

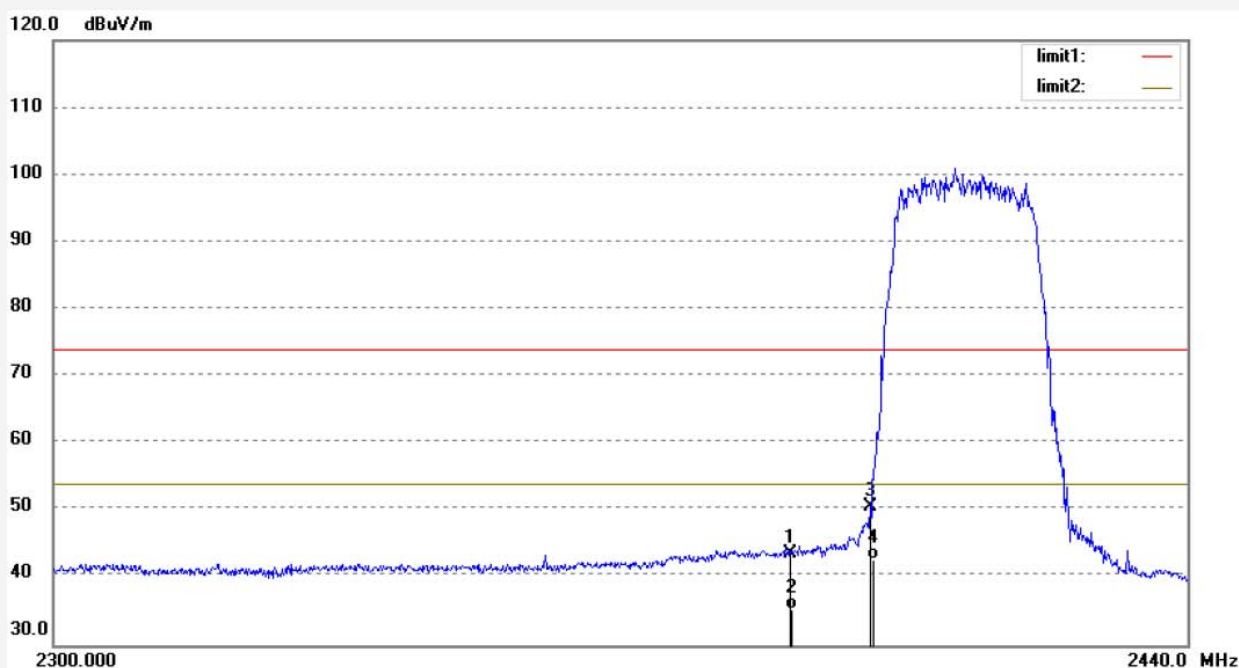

No.	Freq. (MHz)	Reading (dBuV/m)	Factor (dB)	Result (dBuV/m)	Limit (dBuV/m)	Margin (dB)	Detector	Height (cm)	Degree (deg.)	Remark
1	2390.000	47.94	-4.32	43.62	74.00	-30.38	peak	250	193	
2	2390.000	39.50	-4.32	35.18	54.00	-18.82	AVG	250	97	
3	2400.000	54.86	-4.27	50.59	74.00	-23.41	peak	250	13	
4	2400.000	46.98	-4.27	42.71	54.00	-11.29	AVG	250	125	

Job No.: FRANK2019 #197

Standard: FCC PK

Test item: Radiation Test

Temp.(C)/Hum.(%) 25 C / 55 %

EUT: SMART WI-FI HUMIDIFIER

Mode: TX Channel 1(802.11N20)

Model: MW3038

Manufacturer: Guangdong Mixwell Technology Co.,Ltd.

Polarization: Vertical

Power Source: AC 120V/60Hz

Date: 19/08/12/

Time: 16/03/57

Engineer Signature:

Distance: 3m

Note: Report NO.:ATE20191168

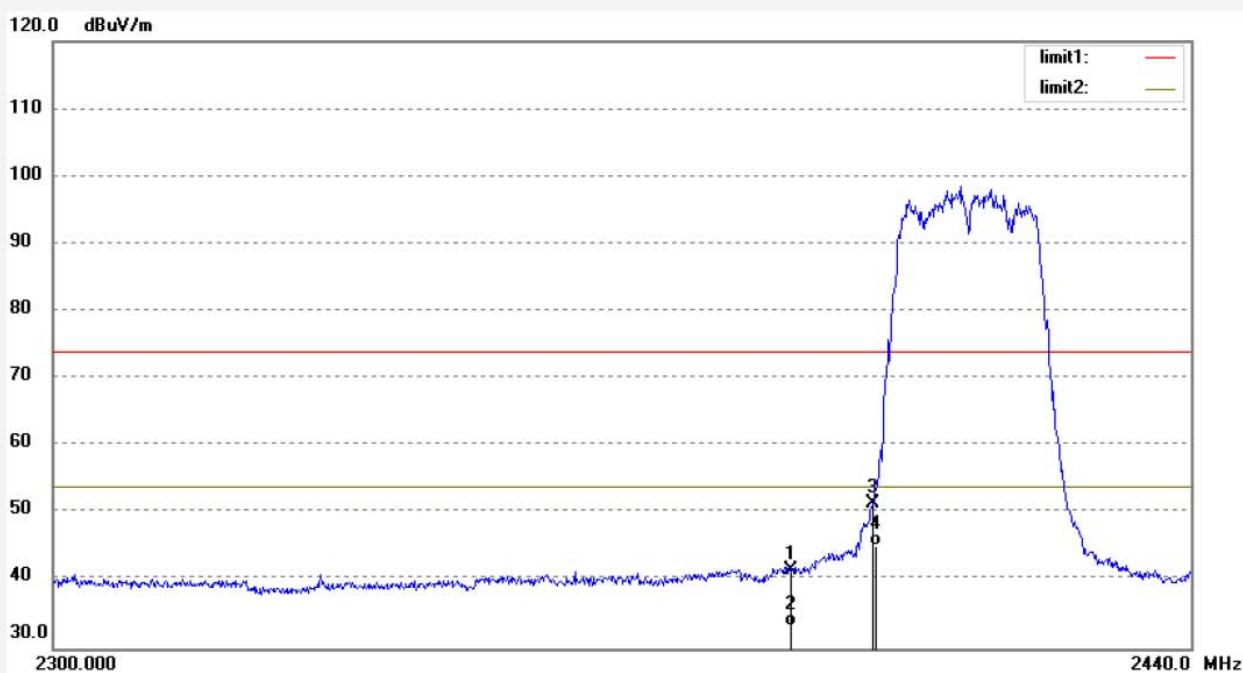

No.	Freq. (MHz)	Reading (dBuV/m)	Factor (dB)	Result (dBuV/m)	Limit (dBuV/m)	Margin (dB)	Detector	Height (cm)	Degree (deg.)	Remark
1	2390.000	45.91	-4.32	41.59	74.00	-32.41	peak	250	89	
2	2390.000	37.61	-4.32	33.29	54.00	-20.71	AVG	150	215	
3	2400.000	55.79	-4.27	51.52	74.00	-22.48	peak	300	197	
4	2400.000	49.46	-4.27	45.19	54.00	-8.81	AVG	150	51	

Job No.: FRANK2019 #203

Standard: FCC PK

Test item: Radiation Test

Temp.(C)/Hum.(%) 25 C / 55 %

EUT: SMART WI-FI HUMIDIFIER

Mode: TX Channel 11(802.11N20)

Model: MW3038

Manufacturer: Guangdong Mixwell Technology Co.,Ltd.

Polarization: Horizontal

Power Source: AC 120V/60Hz

Date: 19/08/12/

Time: 16/15/20

Engineer Signature:

Distance: 3m

Note: Report NO.:ATE20191168

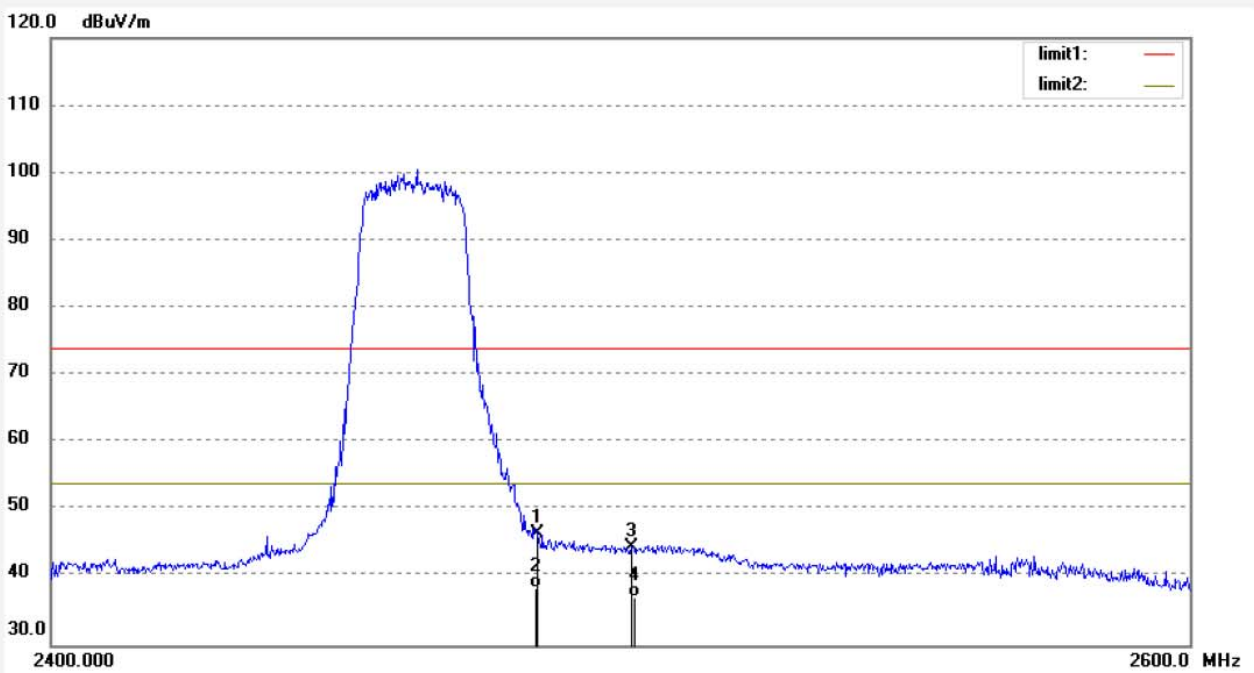

No.	Freq. (MHz)	Reading (dBuV/m)	Factor (dB)	Result (dBuV/m)	Limit (dBuV/m)	Margin (dB)	Detector	Height (cm)	Degree (deg.)	Remark
1	2483.500	50.53	-3.89	46.64	74.00	-27.36	peak	250	169	
2	2483.500	42.35	-3.89	38.46	54.00	-15.54	AVG	250	154	
3	2500.000	48.26	-3.81	44.45	74.00	-29.55	peak	250	45	
4	2500.000	40.91	-3.81	37.10	54.00	-16.90	AVG	250	135	

Job No.: FRANK2019 #202

Standard: FCC PK

Test item: Radiation Test

Temp.(C)/Hum.(%) 25 C / 55 %

EUT: SMART WI-FI HUMIDIFIER

Mode: TX Channel 11(802.11N20)

Model: MW3038

Manufacturer: Guangdong Mixwell Technology Co.,Ltd.

Polarization: Vertical

Power Source: AC 120V/60Hz

Date: 19/08/12/

Time: 16/13/27

Engineer Signature:

Distance: 3m

Note: Report NO.:ATE20191168

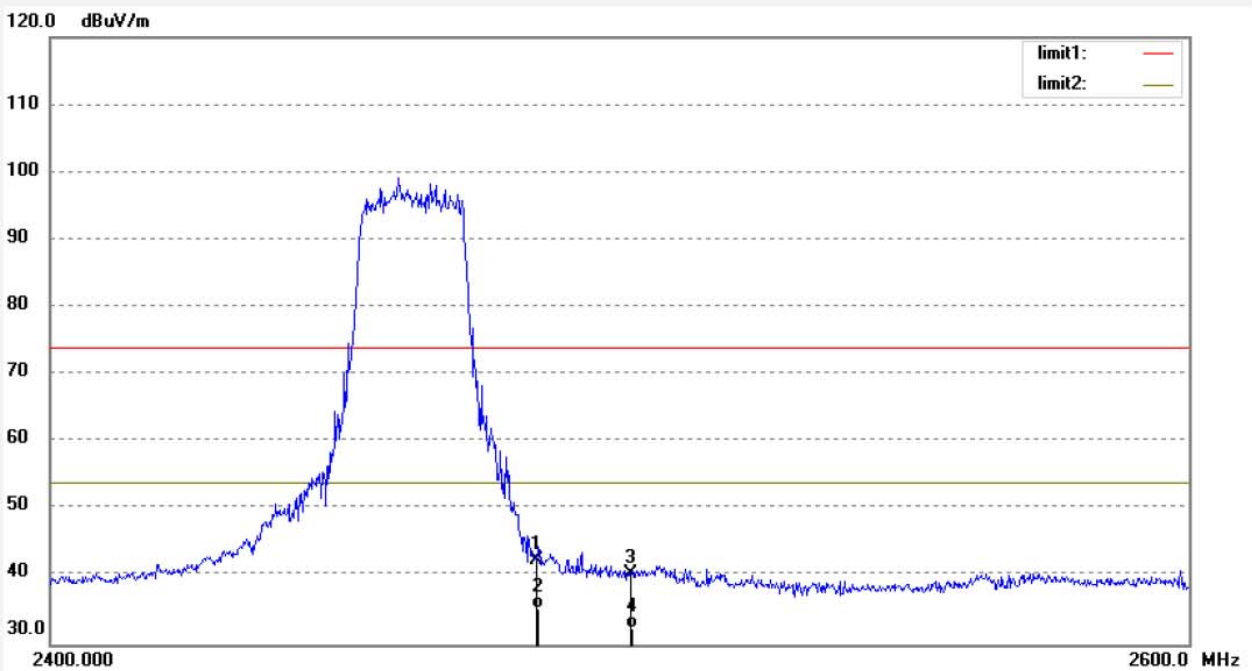

No.	Freq. (MHz)	Reading (dBuV/m)	Factor (dB)	Result (dBuV/m)	Limit (dBuV/m)	Margin (dB)	Detector	Height (cm)	Degree (deg.)	Remark
1	2483.500	46.47	-3.89	42.58	74.00	-31.42	peak	250	193	
2	2483.500	39.16	-3.89	35.27	54.00	-18.73	AVG	150	102	
3	2500.000	44.37	-3.81	40.56	74.00	-33.44	peak	200	79	
4	2500.000	36.20	-3.81	32.39	54.00	-21.61	AVG	150	260	

12. POWER LINE CONDUCTED MEASUREMENT

12.1. Block Diagram of Test Setup

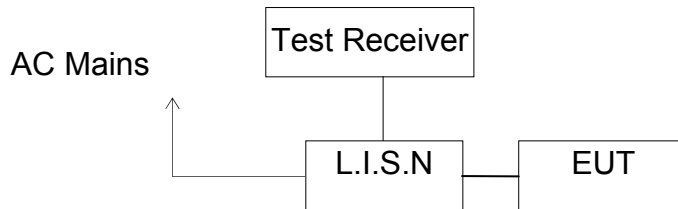

(EUT: SMART WI-FI HUMIDIFIER)

12.2. Power Line Conducted Emission Measurement Limits

Frequency (MHz)	Limit dB(μ V)	
	Quasi-peak Level	Average Level
0.15 - 0.50	66.0 – 56.0 *	56.0 – 46.0 *
0.50 - 5.00	56.0	46.0
5.00 - 30.00	60.0	50.0

NOTE1: The lower limit shall apply at the transition frequencies.
 NOTE2: The limit decreases linearly with the logarithm of the frequency in the range 0.15MHz to 0.50MHz.

12.3. Configuration of EUT on Measurement

The following equipments are installed on Power Line Conducted Emission Measurement to meet the commission requirement and operating regulations in a manner, which tends to maximize its emission characteristics in a normal application.

12.4. Operating Condition of EUT

12.4.1. Setup the EUT and simulator as shown as Section 12.1.

12.4.2. Turn on the power of all equipment.

12.4.3. Let the EUT work in test mode and measure it.

12.5. Test Procedure

The EUT is put on the plane 0.8 m high above the ground by insulating support and is connected to the power mains through a line impedance stabilization network (L.I.S.N.). This provides a 50ohm coupling impedance for the EUT system. Please refer the block diagram of the test setup and photographs. Both sides of AC lines are checked to find out the maximum conducted emission. In order to find the maximum emission levels, the relative positions of equipment and all of the interface cables shall be changed according to ANSI C63.10: 2013 on Conducted Emission Measurement.

The bandwidth of test receiver (R & S ESCS30) is set at 9kHz.

The frequency range from 150kHz to 30MHz is checked.

12.6. DATA SAMPLE

Frequency (MHz)	Quasi Peak Level (dB μ v)	Average Level (dB μ v)	Transducer value (dB)	QuasiPeak Result (dB μ v)	Average Result (dB μ v)	Quasi Peak Limit (dB μ v)	Average Limit (dB μ v)	QuasiPeak Margin (dB)	Average Margin (dB)	Remark (Pass/Fail)
X.XX	29.4	18.3	11.1	40.5	29.4	56.0	56.0	15.5	16.6	Pass

Transducer value = Insertion loss of LISN + Cable Loss
 Result = Quasi-peak Level/Average Level + Transducer value
 Limit = Limit stated in standard

Calculation Formula:

Margin = Limit – Reading level value – Transducer value

12.7.Power Line Conducted Emission Measurement Results

PASS.

The frequency range from 150kHz to 30MHz is checked.

Test mode : WIFI operation (worse case) Test Voltage: 120V/60Hz								
MEASUREMENT RESULT: "CZ-1166-1_fin"								
2019-8-12 8:59								
Frequency	Level	Transd	Limit	Margin	Detector	Line	PE	
MHz	dBuV	dB	dBuV	dB				
0.154000	57.20	10.8	66	8.6	QP	L1	GND	
0.364000	35.00	10.9	59	23.6	QP	L1	GND	
1.770000	39.80	11.2	56	16.2	QP	L1	GND	
4.595000	38.20	11.4	56	17.8	QP	L1	GND	
5.200000	32.40	11.4	60	27.6	QP	L1	GND	
15.920000	32.40	11.7	60	27.6	QP	L1	GND	
MEASUREMENT RESULT: "CZ-1166-1_fin2"								
2019-8-12 8:59								
Frequency	Level	Transd	Limit	Margin	Detector	Line	PE	
MHz	dBuV	dB	dBuV	dB				
0.154000	39.70	10.8	56	16.1	AV	L1	GND	
0.530000	20.80	11.0	46	25.2	AV	L1	GND	
1.770000	35.90	11.2	46	10.1	AV	L1	GND	
4.385000	32.60	11.4	46	13.4	AV	L1	GND	
5.305000	29.00	11.4	50	21.0	AV	L1	GND	
24.045000	23.70	11.7	50	26.3	AV	L1	GND	
MEASUREMENT RESULT: "CZ-1166-2_fin"								
2019-8-12 9:01								
Frequency	Level	Transd	Limit	Margin	Detector	Line	PE	
MHz	dBuV	dB	dBuV	dB				
0.152000	56.20	10.8	66	9.7	QP	N	GND	
0.406000	30.40	11.0	58	27.3	QP	N	GND	
1.776000	37.10	11.2	56	18.9	QP	N	GND	
4.175000	35.70	11.4	56	20.3	QP	N	GND	
8.825000	35.00	11.5	60	25.0	QP	N	GND	
15.860000	34.10	11.7	60	25.9	QP	N	GND	
MEASUREMENT RESULT: "CZ-1166-2_fin2"								
2019-8-12 9:01								
Frequency	Level	Transd	Limit	Margin	Detector	Line	PE	
MHz	dBuV	dB	dBuV	dB				
0.162000	37.80	10.8	55	17.6	AV	N	GND	
0.776000	21.60	11.1	46	24.4	AV	N	GND	
1.774000	32.50	11.2	46	13.5	AV	N	GND	
3.545000	32.50	11.4	46	13.5	AV	N	GND	
5.305000	30.50	11.4	50	19.5	AV	N	GND	
15.860000	28.30	11.7	50	21.7	AV	N	GND	

Emissions attenuated more than 20 dB below the permissible value are not reported.

All the test modes completed for test. Only the worst result of AC 120V/60Hz (802.11b at 2412MHz) is reported. The spectral diagrams are attached as below.

ACCURATE TECHNOLOGY CO., LTD

CONDUCTED EMISSION STANDARD FCC PART 15B

EUT: SMART WI-FI HUMIDIFIER M/N:MW3038
 Manufacturer: Guangdong Mixwell Technology Co.,Ltd
 Operating Condition: WIFI OPERATION
 Test Site: 2#Shielding Room
 Operator: Frank
 Test Specification: N 120V/60Hz
 Comment: Report NO.:ATE20191168
 Start of Test: 2019-8-12 / 9:00:16

SCAN TABLE: "V 150K-30MHz fin"

Short Description: _SUB_STD_VTERM2 1.70
 Start Stop Step Detector Meas. IF Transducer
 Frequency Frequency Width Time Bandw.
 150.0 kHz 30.0 MHz 4.5 kHz QuasiPeak 1.0 s 9 kHz NSLK8126 2008
 Average

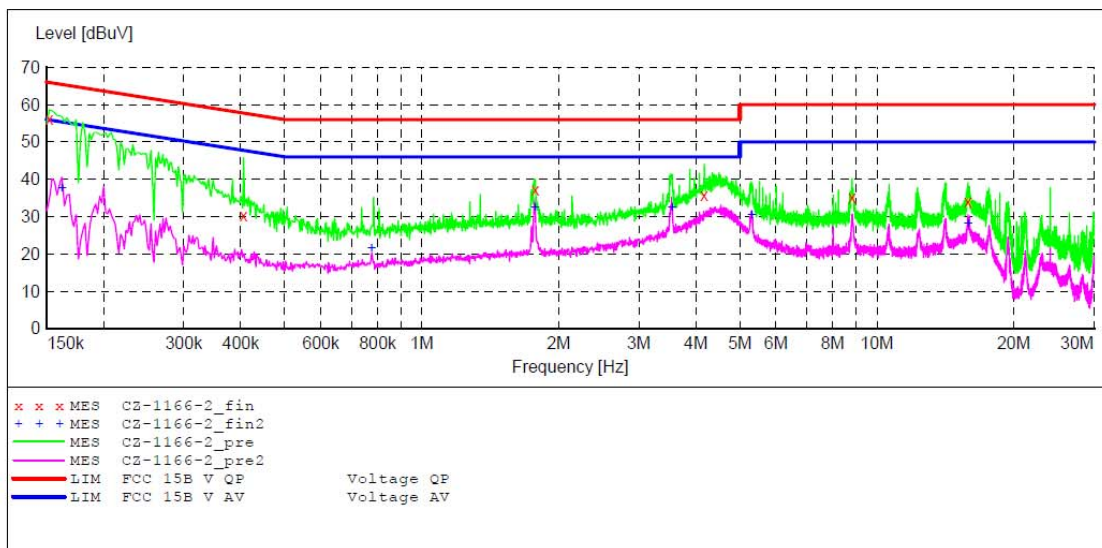

MEASUREMENT RESULT: "CZ-1166-2_fin"

2019-8-12 9:01

Frequency MHz	Level dBuV	Transd dB	Limit dBuV	Margin dB	Detector	Line	PE
0.152000	56.20	10.8	66	9.7	QP	N	GND
0.406000	30.40	11.0	58	27.3	QP	N	GND
1.776000	37.10	11.2	56	18.9	QP	N	GND
4.175000	35.70	11.4	56	20.3	QP	N	GND
8.825000	35.00	11.5	60	25.0	QP	N	GND
15.860000	34.10	11.7	60	25.9	QP	N	GND

MEASUREMENT RESULT: "CZ-1166-2_fin2"

2019-8-12 9:01

Frequency MHz	Level dBuV	Transd dB	Limit dBuV	Margin dB	Detector	Line	PE
0.162000	37.80	10.8	55	17.6	AV	N	GND
0.776000	21.60	11.1	46	24.4	AV	N	GND
1.774000	32.50	11.2	46	13.5	AV	N	GND
3.545000	32.50	11.4	46	13.5	AV	N	GND
5.305000	30.50	11.4	50	19.5	AV	N	GND
15.860000	28.30	11.7	50	21.7	AV	N	GND

ACCURATE TECHNOLOGY CO.,LTD

CONDUCTED EMISSION STANDARD FCC PART 15B

EUT: SMART WI-FI HUMIDIFIER M/N:MW3038
 Manufacturer: Guangdong Mixwell Technology Co.,Ltd
 Operating Condition: WIFI OPERATION
 Test Site: 2#Shielding Room
 Operator: Frank
 Test Specification: L 120V/60Hz
 Comment: Report NO.:ATE20191168
 Start of Test: 2019-8-12 / 8:58:07

SCAN TABLE: "V 150K-30MHz fin"

Short Description: _SUB STD VTERM2 1.70

Start Frequency	Stop Frequency	Step Width	Detector	Meas. Time	IF Bandw.	Transducer
150.0 kHz	30.0 MHz	4.5 kHz	QuasiPeak	1.0 s	9 kHz	NSLK8126 2008

Average

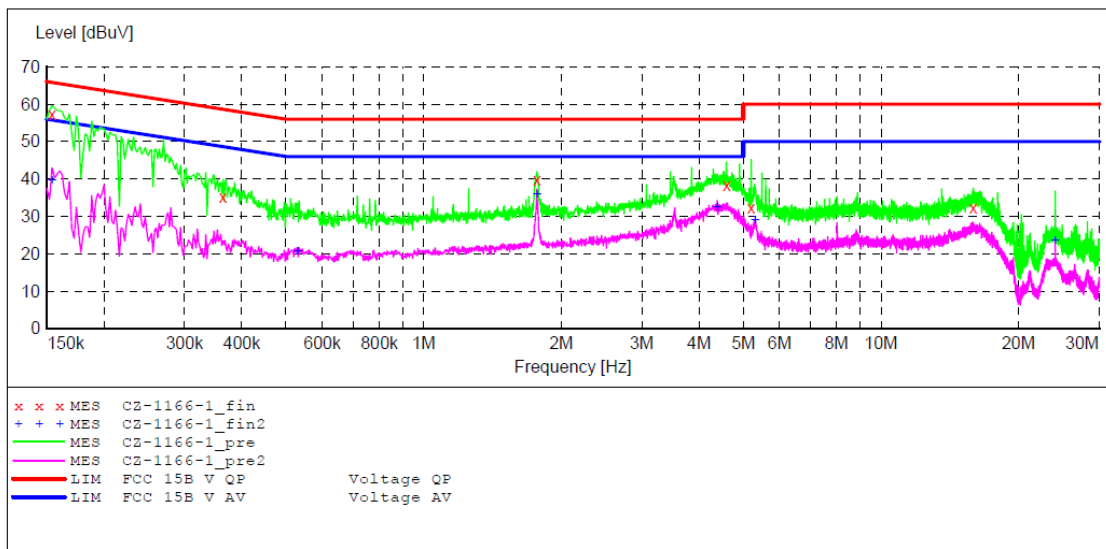

MEASUREMENT RESULT: "CZ-1166-1_fin"

2019-8-12 8:59

Frequency MHz	Level dBuV	Transd dB	Limit dBuV	Margin dB	Detector	Line	PE
0.154000	57.20	10.8	66	8.6	QP	L1	GND
0.364000	35.00	10.9	59	23.6	QP	L1	GND
1.770000	39.80	11.2	56	16.2	QP	L1	GND
4.595000	38.20	11.4	56	17.8	QP	L1	GND
5.200000	32.40	11.4	60	27.6	QP	L1	GND
15.920000	32.40	11.7	60	27.6	QP	L1	GND

MEASUREMENT RESULT: "CZ-1166-1_fin2"

2019-8-12 8:59

Frequency MHz	Level dBuV	Transd dB	Limit dBuV	Margin dB	Detector	Line	PE
0.154000	39.70	10.8	56	16.1	AV	L1	GND
0.530000	20.80	11.0	46	25.2	AV	L1	GND
1.770000	35.90	11.2	46	10.1	AV	L1	GND
4.385000	32.60	11.4	46	13.4	AV	L1	GND
5.305000	29.00	11.4	50	21.0	AV	L1	GND
24.045000	23.70	11.7	50	26.3	AV	L1	GND

13.ANTENNA REQUIREMENT

13.1.The Requirement

According to Section 15.203, an intentional radiator shall be designed to ensure that no antenna other than that furnished by the responsible party shall be used with the device.

13.2.Antenna Construction

Device is equipped with permanent attached antenna, which isn't displaced by other antenna. The Antenna gain of EUT is 2.51dBi. Therefore, the equipment complies with the antenna requirement of Section 15.203.

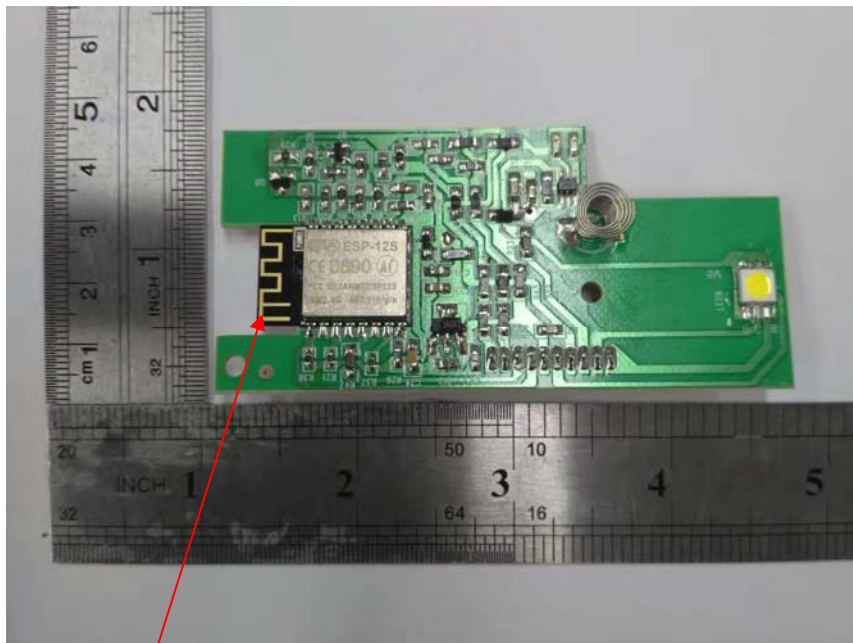

Antenna