

PREFACE

Thank you for selecting a Hero MotoCorp **DUET** scooter. We wish you many miles of continued riding pleasure in the years ahead.

We, at Hero MotoCorp, are committed to demonstrate excellence in our environment performance on a continual basis, as an intrinsic element of our corporate philosophy. To achieve this we commit ourselves to continue product innovations to improve environment compatibility, comply with all applicable legislation including environment legislation and strengthen the green supply chain.

Your Scooter is conforming to latest (Bharat Stage-III norms) regulation for emission, safety & noise levels. We are also using non asbestos brake shoes and engine gaskets which are environment friendly in nature.

This booklet is your guide to the basic operation and maintenance of your new Hero MotoCorp **DUET** scooter. Please take time to read it carefully. As with any fine machine, proper care and maintenance is essential for trouble-free operation and optimum performance.

Your Authorised Hero MotoCorp dealer will be glad to provide further information or assistance and is equipped to handle your future service needs.

Let us make this world a safer, healthier and more environment friendly place.

 **NOTE**

ALL INFORMATION, ILLUSTRATION, PHOTOGRAPH, DIRECTIONS, SPECIFICATIONS AND OTHER CONTENTS COVERED IN THIS OWNER'S MANUAL ARE BASED ON THE LATEST PRODUCT INFORMATION AVAILABLE AT THE TIME OF ITS PRINTING APPROVAL, AND THE ACCURACY OR CORRECTNESS OF THE SAME IS NOT UNDERTAKEN OR GUARANTEED. Hero MotoCorp Ltd RESERVES THE RIGHT TO MAKE CHANGES IN ITS CONTENTS AT ANY TIME WITHOUT NOTICE AND/OR INCURRING ANY OBLIGATION, WHATSOEVER. NO ONE IS ALLOWED TO REPRODUCE ANY PART OF THIS PUBLICATION WITHOUT OBTAINING PRIOR WRITTEN PERMISSION FROM Hero MotoCorp Ltd.

ACCESSORIES SHOWN MAY NOT BE THE PART OF STANDARD FITMENT. IT IS OUR ENDEAVOUR TO CONSTANTLY IMPROVE OUR PRODUCTS. THIS COULD LEAD TO CHANGE IN PRODUCT SPECIFICATIONS WITHOUT NOTICE. Hero MotoCorp Ltd 'DUET' COMPLIES WITH THE LATEST EMISSION NORMS.

CONTENTS

	Pg. No.	Pg. No.
SCOOTER IDENTIFICATION	1	35
PRODUCT SPECIFICATION	2	36
SCOOTER SAFETY	4	37
‣ Important safety information	4	OPERATIONS
‣ Protective apparel	5	‣ Pre-ride inspection
‣ Load limits and guidelines	7	‣ Anti-theft tips/Starting the engine
‣ Accessories and modifications	8	‣ Running in/Riding
TIPS FOR HEALTHY ENVIRONMENT	9	‣ Parking/Steering lock
SCOOTER VIEWS	10	TOOL KIT/FIRST AID KIT
PARTS FUNCTION	13	MAINTENANCE
‣ Fuel gauge/Odometer/Tripmeter	15	‣ Importance of maintenance
‣ Service reminder	15	‣ Maintenance safety/Safety precautions
‣ Keys	16	‣ Maintenance schedule
MAJOR COMPONENTS	16	‣ Air cleaner
‣ Brakes (integrated braking)	16	‣ Throttle operation
‣ Fuel	18	‣ Secondary air supply system
‣ Tyres (Tubeless)	20	‣ Drain tube/Engine oil
ESSENTIAL INDIVIDUAL COMPONENTS	24	‣ Engine oil replacement/Oil strainer cleaning
‣ Ignition switch	24	‣ Final drive oil replacement
‣ Right handle bar controls	25	‣ Spark plug
‣ Left handle bar controls	25	‣ Idle speed/Brake shoe wear
FEATURES	26	‣ Battery
‣ Steering lock/Fuel filler cap	26	‣ Fuse replacement
‣ Seat lock/Helmet holder	26	‣ Suspension/Bulb replacement
‣ Center/Document/First aid kit compartment	27	‣ Cleaning/Washing
‣ Boot lamp/Boot lamp switch	28	‣ Polishing
‣ Mobile charging USB port	28	STORAGE GUIDE
‣ Luggage hook	29	‣ Storage
‣ Front inner box/Side stand indicator	30	‣ Removal from storage
‣ Side stand switch/Side stand	31	‣ Catalytic converter/Air suction valve
‣ Pillion footrest	31	BASIC TROUBLESHOOTING
BODY PARTS REMOVAL	32	ROAD SIGNS
‣ Center cover/Center compartment	32	WARRANTY DETAILS
‣ Body cover	32	HERO GENUINE PARTS
‣ Front center cover	34	ZONAL/REGIONAL/AREA OFFICES

SCOOTER IDENTIFICATION

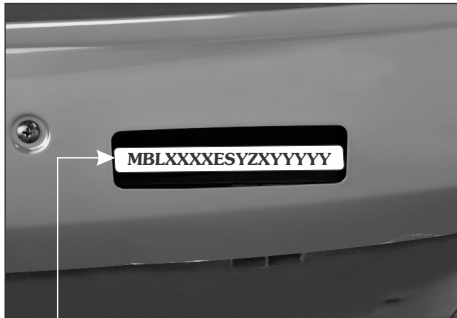

Vehicle Identification Number (VIN)

Location: Stamped on the lower right side of the frame, visible from the window provided on right floor side cover.

VIN: MBLXXXESYZXYYYYY

MBL	XXXES	Y	Z	X	YYYYY
Manufacturer code	Vehicle Description	Year of Manufacturing	Assembly Plant	Month of Manufacturing	Serial Number

Engine No.: XXXXAAYZXYYYYY

XXXXAA	Y	Z	X	YYYYY
Engine Description	Year of Manufacturing	Assembly Plant	Month of Manufacturing	Serial Number

Model: DUET

Variants	VIN	Engine
Telescopic suspension system/Integrated braking (VX)	ES	AA
Bottom link suspension type/Integrated braking (LX)	ET	AA

VIN and Engine No. may be required:

1. During registration of the scooter.
2. For dealing with Legal & Insurance Departments.

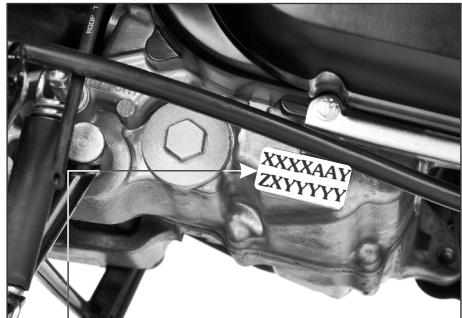

Engine No.

Location: Stamped on the lower side of the left crankcase.

PRODUCT SPECIFICATION

ITEM		SPECIFICATIONS
Dimensions		
Overall length		1830 mm
Overall width		726 mm
Overall height		1139 mm
Wheelbase	VX Model	1245 mm
	LX Model	1241 mm
Saddle height		770 mm
Ground clearance		155 mm
Weight		
Kerb weight	VX Model	116 kg
	LX Model	115 kg
Capacities		
Engine oil		0.80 litre at disassembly and 0.70 litre at draining
Transmission oil		0.12 litre at disassembly
		0.10 litre at draining
Fuel tank		5.5 litres (Minimum)
Engine		
Maximum power		6.20 kW @ 8000 r/min
Maximum torque		8.30 N-m @ 6500 r/min
Bore and stroke		50.0x56.5 mm
Compression ratio		9.5:1
Displacement		110.9 cc
Spark plug		Champion-PRZ 9 HC (Federal Mogul)
Spark plug gap		0.6-0.7 mm
Valve clearance	Intake (cold)	0.14 mm
	Exhaust (cold)	0.14 mm
Idle speed		1500±200 r/min
Chassis and suspension		
Chassis Type		High rigidity under bone
Front Suspension	VX Model	Telescopic, hydraulic shock absorber
	LX Model	Bottom link with spring loaded hydraulic damper
Rear Suspension		Unit swing with spring loaded hydraulic damper
Caster angle		27.5°

PRODUCT SPECIFICATION

ITEM		SPECIFICATIONS
Tyre size	Front	90/100x10-53 J (Tubeless tyre)
	Rear	90/100x10-53 J (Tubeless tyre)
Front/Rear brake Drum type		Internal expanding shoe type (Dia. 130 mm) (Integrated braking)
Transmission		
Primary reduction		Variomatic drive, (2.51-0.85)
Final reduction		50/20x50/12 (10.417)
Clutch system		Dry, Automatic Centrifugal Clutch
Electricals		
Battery	VX Model	12V-4Ah ETZ5 *MF battery
	LX Model	12V-5Ah-Conventional type battery
Alternator		110 W
Starting System		Kick/Electric start
Headlamp (High/Low)		12V-35/35W Halogen bulb-MFR**
Position lamp		12V-5W
Tail/Stop lamp		12V-5/21W
Turn signal lamp		12V-21W x4 nos.(MFR**-Clear Lens-Amber bulb)
Meter Illumination	VX Model	LED
	LX Model	12V-1.7W x2nos.
Turn signal indicator	VX Model	LED x2nos.
	LX Model	12V-3W x2nos.
Hi Beam indicator	VX Model	LED
	LX Model	12V-3.0W
Licence plate		12V-5W
Side stand indicator	VX Model	LED
	LX Model	12V-1.7W
Fuse		10A

* MF stands for Maintenance Free

** MFR stands for Multi-Focal Reflector

SCOOTER SAFETY

IMPORTANT SAFETY INFORMATION

Your scooter can provide many years of service and pleasure if you take responsibility for your own safety and understand the challenges you can meet on the road.

There is much that you can do to protect yourself when you ride. You will find many helpful recommendations throughout this manual. Following are a few that we consider most important.

Always wear a helmet

It is a proven fact, Helmet significantly reduces the number and severity of head injuries. So always wear a helmet and make sure your pillion rider does the same. We also recommend that you wear eye protection, sturdy boots, gloves and other protective gear (**page 6**).

Before riding your scooter

Make sure that you are physically fit, mentally focused and free of alcohol and drugs. Check that you and your pillion are both wearing an approved scooter helmet and protective apparel. Instruct your pillion on holding onto the grab rail or your waist, leaning with you in turns, and keeping their feet on the foot pegs, even when the scooter is stopped.

Take time to learn & practice your scooter

Even if you have ridden other scooters, practice riding in a safe area to become familiar with how this scooter works and handles, and to become accustomed to the scooter's size and weight.

Ride defensively

Always pay due attention to other vehicles around you, and do not assume that other drivers see you. Be prepared to stop quickly or perform an evasive maneuver.

Make yourself easily visible

Some drivers do not see scooters because they are not looking for them. To make yourself more visible, wear bright reflective clothing, position yourself so that others can see you, signal before turning or changing lanes, and use horn which will help others to notice you.

Ride within your limits

Pushing the limits is another major cause of scooter accidents. Never ride beyond your personal abilities or faster than conditions demand. Remember that fatigue and negligence can significantly reduce your ability to make good judgements and ride safely.

Do not drink and ride

Riding under the influence of alcohol or drugs is dangerous. Alcohol can reduce your ability to respond to changing conditions and reduce the reaction time. Do not drink and ride.

Keep your scooter in safe condition

For safe riding, its important to inspect your scooter before every ride and perform all recommended maintenance. Never exceed load limits, and use accessories that have been recommended by Hero MotoCorp for this vehicle. See (**page 7 & 8**) for more details.

If you are involved in a crash

Personal safety is your first priority. If you or anyone else has been injured, take time to assess the severity of the injuries and whether it is safe to continue riding. Call for emergency assistance if needed. Also follow applicable laws and regulations if another person or vehicle is involved in the crash.

If you decide to continue riding, first evaluate the condition of your scooter. If the engine is still running, turn it off. Inspect for fluid leaks, check the tightness of critical nuts and bolts, and check the handlebar, brake levers, brakes, and wheels. Ride slowly and cautiously. Your scooter may have suffered damage that is not immediately apparent. Have your scooter thoroughly checked at a qualified service facility as soon as possible.

PROTECTIVE APPAREL

For your safety, we strongly recommend that you always wear an approved helmet (ISI marked), eye protection, boots, gloves, long pants and a long sleeve shirt or jacket whenever you ride. Take care of loose/hanging clothes while solo/pillion riding. Although complete protection is not possible, wearing proper gear can reduce the chance of injury when you ride.

Following are suggestions to help you choose proper riding gear.

WARNING

- ▶ *Not wearing a helmet increases the chance of serious injury or death in a crash.*
- ▶ *Be sure you and your pillion always wear a helmet, eye protection and other protective apparel when you ride.*

Helmets and eye protection

Your Helmet is your most important piece of riding gear because it offers the best protection against head injuries. A helmet should fit your head comfortably and securely. A bright coloured helmet can make you more noticeable in traffic, as can reflective strips.

An open-face helmet offers some protection, but a full-face helmet offers more. Always wear face shield or goggles to protect your eyes and help your vision.

Additional riding gear

In addition to a helmet and eye protection, we also recommend:

- ▶ Sturdy boots with non-slip soles to help protect your feet and ankles.
- ▶ Leather gloves to keep your hands warm and help prevent blisters, cuts, burns, and bruises.
- ▶ A two wheeler riding suit or jacket for comfort as well as protection. Bright coloured reflective clothing can help make you more noticeable in traffic. Be sure to avoid loose clothes that could get caught on any part of your scooter.

PROTECTIVE APPAREL

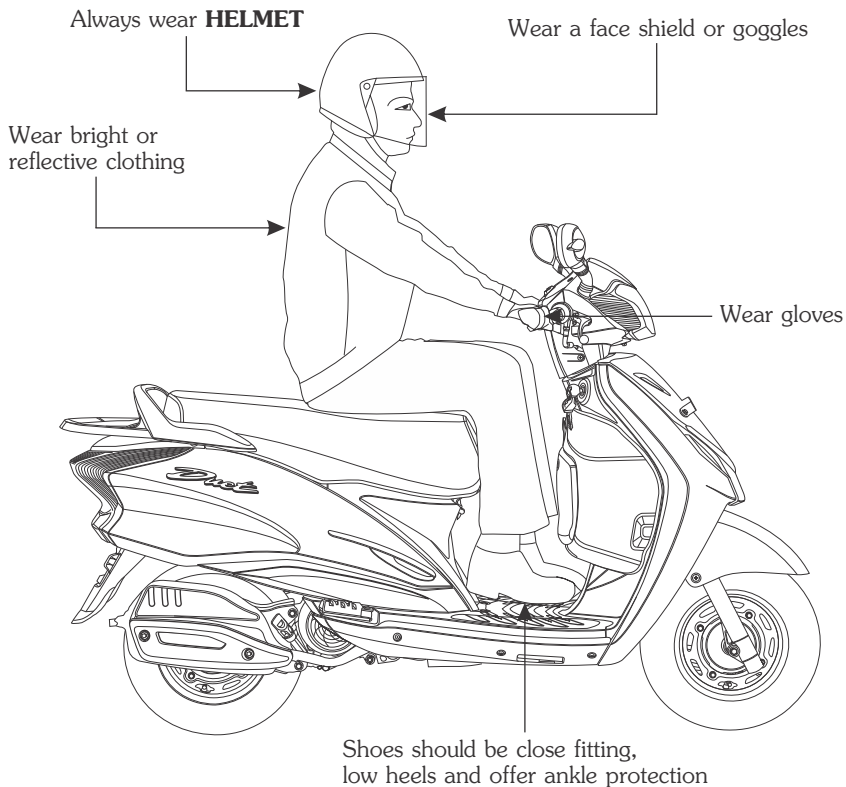

LOAD LIMITS AND GUIDELINES

Your scooter has been designed to carry you, one pillion and limited amount of cargo. When you add cargo or carry a passenger, you may feel some difference during acceleration and braking. But so long as you keep your scooter well maintained, with good tyres and brakes, you can safely carry loads within the limits and guidelines.

However exceeding the weight limit or carrying an unbalanced load can seriously affect your scooter's handling, braking and stability. Non Hero MotoCorp accessories, modifications, and poor maintenance can reduce your safety margin.

The following pages give more specific information on loading, accessories and modifications.

Loading

How much weight you put on your scooter, and how you load it, are important to your safety. Anytime you ride with a pillion or cargo you should be aware of the following information.

⚠ WARNING

- **Overloading or improper loading can cause a crash and you can be seriously injured.**
- **Follow all load limits and other loading guidelines in this manual.**

Load limits

Following are the load limits for your scooter:

Maximum weight capacity: 130 kg

Includes the weight of the rider, pillion, all cargo and all accessories.

Putting too much weight in individual storage compartments can also affect stability and handling. So be sure to stay within the limits given below:

Maximum weight:

Center compartment	: 10.0 kg
Front inner box	: 1.5 kg
Rear Luggage hook	: 3.0 kg
Front luggage hook	: 3.0 kg

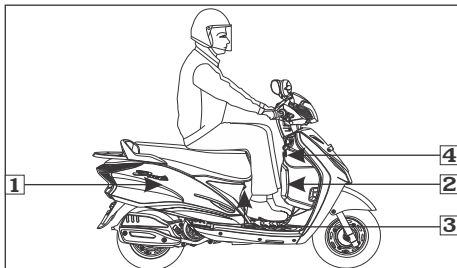

**(1) Center compartment (2) Front inner box
(3) Rear luggage hook (4) Front luggage hook**

Loading guidelines

Your scooter is primarily intended for transporting you and a pillion. If you wish to carry more cargo, check with your Authorised Hero MotoCorp workshop for advice and be sure to read the information regarding accessories on **(page 8)**.

Improperly loading your scooter can affect its stability and handling. Even if your scooter is properly loaded, you should ride at reduced speeds whenever carrying cargo.

Follow these guidelines whenever you carry a pillion or cargo:

- Check that both tyres are properly inflated.
- To prevent loose items from creating a hazard, make sure the center compartment is closed and that any other cargo is securely tied down before you ride away.
- Place cargo weight as close to the center of the scooter as possible.
- Balance cargo weight evenly on both sides.

ACCESSORIES & MODIFICATIONS

Modifying your scooter or using non Hero MotoCorp accessories can make your scooter unsafe. Before you consider making any modifications or adding any accessory, be sure to read the following information.

WARNING

- ***Improper accessories or modifications can cause a crash in which you can be seriously hurt or killed.***
- ***Follow all instructions in this owner's manual regarding accessories and modifications.***

Accessories

We strongly recommend that you use only genuine Hero MotoCorp accessories that have been specifically designed and tested for your scooter. Hero MotoCorp cannot test all other accessories, you must be personally responsible for proper selection, installation and use of non Hero MotoCorp accessories. Check with your dealer for assistance and always follow these guidelines:

- Make sure the accessories does not obstruct any lamps, reduce ground clearance and banking angle, limit suspension travel or steering travel, alter your riding position or interfere with operating any controls.
- Be sure electrical equipment does not exceed the scooter's electrical system capacity. A blown fuse can cause loss of lights (**page 3**).
- Do not pull a trailer or sidecar with your scooter. This scooter is not designed for these attachments, and their use can seriously impair your scooter handling.

Modifications

We strongly advise you not to remove any original equipment or modify your scooter in any way that would change its design or operation. Such changes could seriously impair your scooter's handling, stability and braking, making it unsafe to ride.

Removing or modifying your lamps, muffler, emission control system or other equipment can also make your scooter not meeting the emission standards.

TIPS FOR HEALTHY ENVIRONMENT

The following tips shall ensure a healthy scooter, healthy environment, and a healthy you.

- ▶ **Healthy engine:** The engine is the lifeline of every vehicle. To keep it healthy, it should be tuned regularly, which will also help reduce pollution and improve vehicle performance.
- ▶ **Regular Servicing:** Get your scooter serviced at an Authorised service station, as per the service schedule, for an optimum performance and keep the emission level under check.
- ▶ **Genuine Spares:** Always insist on Hero MotoCorp genuine parts as spurious or incompatible spares and accessories can upset or deteriorate your scooter's running condition.
- ▶ **Genuine engine oil:** Hero 4T Plus SAE 10W 30 SL grade (JASO MB) engine oil recommended by Hero MotoCorp and make sure you change it every 6000 km (with top up every 3000 km) to keep the engine fit and environment healthy.
- ▶ **Noise pollution:** Noise beyond a certain decibel is pollution. Whether it is from horns or defective mufflers, excessive noise will cause headaches and discomfort.
- ▶ **Emission Pollution:** Get emission of your scooter checked by Authorised agencies atleast once every 3 months or as notified by the government from time to time.
- ▶ **Fuel Saving & Reduce Pollution:** Switch "OFF" the engine while waiting at traffic signal points to save fuel and reduce pollution, if the waiting period is long.

TOP VIEW

SCOOTER VIEWS

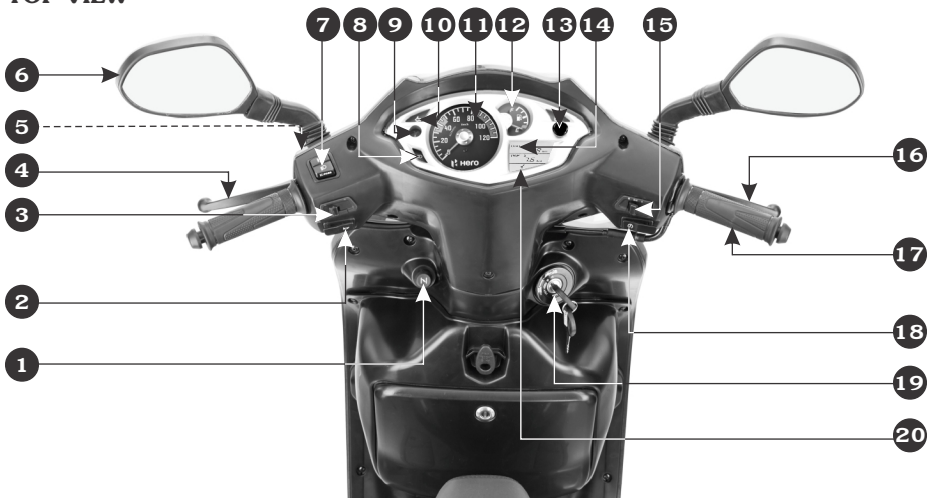

- | | |
|----------------------------|---|
| (1) Choke knob | (11) Speedometer |
| (2) Horn switch | (12) Fuel gauge |
| (3) Turn signal switch | (13) Reset button |
| (4) Integrated brake lever | (14) Odometer |
| (5) Parking lever | (15) Headlamp switch |
| (6) Rear view mirror | (16) Front brake lever |
| (7) Dimmer/Passing switch | (17) Throttle grip |
| (8) Hi-beam indicator | (18) Starter switch |
| (9) Side stand indicator | (19) Ignition switch with steering lock |
| (10) Turn signal indicator | (20) Service reminder |

***Accessories and features shown may not be part of standard fitment.**

LEFT SIDE VIEW

SCOOTER VIEWS



- | | | |
|---------------------------------------|--|-------------------------|
| (1) Side stand switch**
(Optional) | (5) Kick starter pedal | (9) Rear grip |
| (2) Side stand** (Optional) | (6) Women pillion
step** (Optional) | (10) Seat |
| (3) Main stand | (7) Rear turn signal lamp | (11) Boot lamp* |
| (4) Pillion step | (8) Tail/Stop lamp | (12) Rear Luggage hook* |
| | | (13) Headlamp |

***Optional in LX Model **Optional in VX & LX Models**

***Accessories and features shown may not be part of standard fitment.**

RIGHT SIDE VIEW

SCOOTER VIEWS



- | | | |
|----------------------------------|----------------------------|---------------------------------|
| (1) Exhaust muffler | (5) Position lamp | (8) USB charger* (inside) |
| (2) Oil level dipstick | (6) Front turn signal lamp | (9) Center compartment (inside) |
| (3) Pillion step | (7) Front Luggage hook | (10) Rear reflex reflector |
| (4) Front inner box** (Optional) | | |

***Optional in LX Model **Optional in VX & LX Models**

***Accessories and features shown may not be part of standard fitment.**

PART FUNCTIONS (VX MODEL)

Instruments and Indicators

The indicators are in the speedometer panel above the headlamp. The functions are as below.



Sl. No.	Description	Function
1	Side stand indicator	Light glows when the vehicle is parked on the side stand.
2	Turn signal indicator (L)	Flashes when left turn signal switch is operated.
3	Speedometer	Indicates riding speed.
4	Fuel gauge	Indicates approximate fuel quantity (page 15).
5	Turn signal indicator (R)	Flashes when right turn signal switch is operated.
6	Reset button	Button when long pressed resets tripmeter to zero.
7	Service reminder	Displays when a service is due (page 15).
8	Tripmeter	Shows the distance traveled since the last reset (page 15).
9	Odometer	Shows accumulated mileage (page 15).
10	High beam indicator	Light glows when headlamp is in Hi Beam.

PART FUNCTIONS (LX MODEL)

Instruments and Indicators

The indicators are in the speedometer panel above the headlamp. The functions are as below.



Sl. No.	Description	Function
1	Turn signal indicator (L)	Flashes when left turn signal switch is operated.
2	Odometer	Shows accumulated mileage (page 15).
3	Speedometer	Indicates riding speed.
4	Side stand indicator	Light glows when the vehicle is parked on the side stand.
5	Fuel gauge	Indicates approximate fuel quantity (page 15).
6	Turn signal indicator (R)	Flashes when right turn signal switch is operated.
7	High beam indicator	Light glows when headlamp is in Hi Beam.

FUEL GAUGE

When the fuel gauge (1) needle enters the red band (2), fuel will be low and you should refill the tank as soon as possible. The amount of fuel left in the tank when the needle enters the red band is approximately 1.2 Litres.

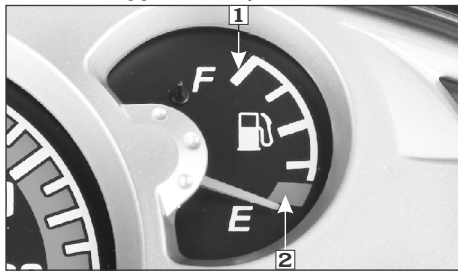

(1) Fuel gauge

(2) Red band

LCD PANEL

ODOMETER/TRIPMETER

The odometer (1) shows accumulated distance traveled.

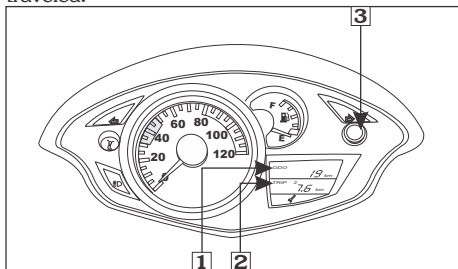

(1) Odometer (2) Tripmeter (3) Reset button

The tripmeter (2) shows distance traveled since trip meter was reset last time.

Tripmeter displays upto 999.9 km. If the tripmeter exceeds "999.9" km it will return to "0.0" km automatically.

When tripmeter is selected long press the reset button (3) to reset tripmeter to zero.

The odometer displays from "0 to 999999" km.

SERVICE REMINDER

The Service reminder (1) is to indicate to an user to bring the vehicle to an Authorised Hero MotoCorp workshop for service.

The service reminder shall start blinking when the vehicle covers kilometers as specified in the maintenance schedule. The indicator will keep on blinking throughout the kilometer interval for a particular service and will stay "ON" thereafter.

The Service Reminder can be reset at Authorised Hero MotoCorp workshop.

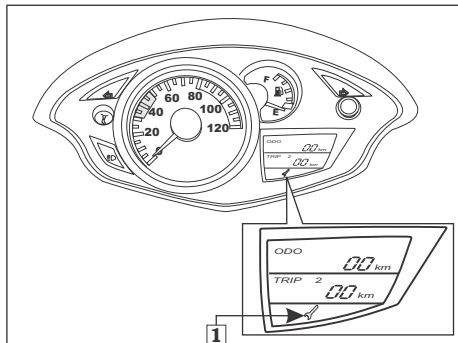

(1) Service reminder

TOTAL DISTANCE (Odometer Reading)	Indicator Behaviour
0 km	OFF
500 - 750 km	Blinking
After 750 km	ON
3000 - 3500 km	Blinking
After 3500 km	ON
6000 - 6500 km	Blinking
After 6500 km	ON
•	•
•	•
•	•

NOTE

After getting the vehicle serviced, make sure that the Service reminder has been reset.

KEYS

This scooter has two keys and a key number plate.

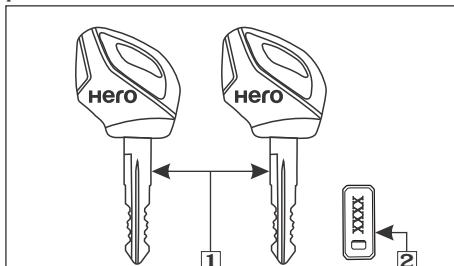

(1) Keys

(2) Key number plate

You will need the key number if you ever have to replace a key. Store the plate in a safe place.

MAJOR COMPONENTS

(Information you need to operate this scooter)

BRAKES (Integrated braking)

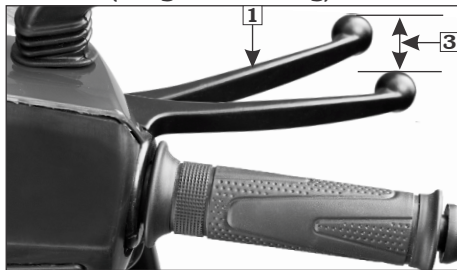

(1) Front brake lever

(3) Free play 10-20 mm

Brakes are items of personal safety and should always be maintained with proper adjustments.



(2) Integrated brake lever

(3) Free play 10-20 mm

When one applies the left lever, front & rear brakes activate jointly.

The distance, the front brake lever (1) and integrated brake lever (2) moves before each brake starts to engage is called free play (3). Measured at the tip of brake levers, free play should be maintained at 10–20 mm.

Adjustment

Right hand front brake cable (A) on “1 or F” side

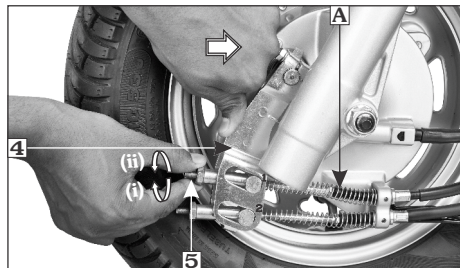

- ▶ Push the integrated brake arm (4) by hand in the direction as shown.
- ▶ Turn the first adjuster nut (5) till you cannot turn it by hand.
- ▶ Check the free play of right lever.

FREE PLAY: 10–20 mm

- ▶ If the free play is more than 20 mm further turn the adjuster nut to obtain desired free play.

Left hand front brake cable (B) on “2 or I” side.

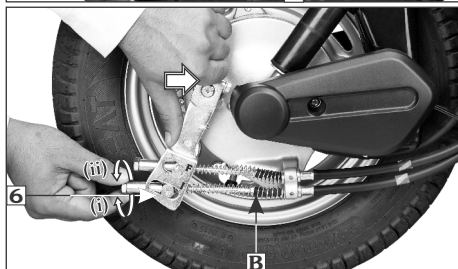
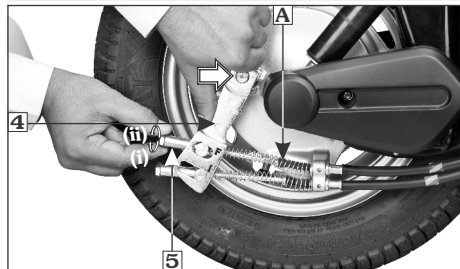
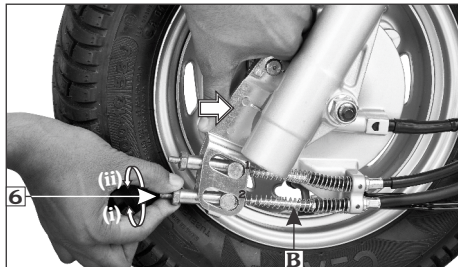

(4) Integrated brake arm (5) First adjuster nut
(i) Decrease free play (ii) Increase free play

(6) Second adjuster nut
(i) Decrease free play (ii) Increase free play

- Push the integrated brake arm (4) by hand in the direction as shown.
- Turn the second adjuster nut (6) until a gap is created between joint (7) and the slot on the first side in integrated brake arm.
- After ensuring the gap, turn the second adjuster nut counter-clockwise by half rotation.

NOTE

- “1” & “2” is marked on integrated brake arm for VX model.
- “F” & “I” is marked on integrated brake arm for LX model.
- Adjustment is same for LX & VX model.

Rear brake

- Make free play adjustment by turning the adjuster nut (8) in the brake arm (9).
- Check the free play of integrated brake lever.

FREE PLAY: 10–20 mm

- If the free play is more than 20 mm further turn the adjuster nut to obtain desired free play.

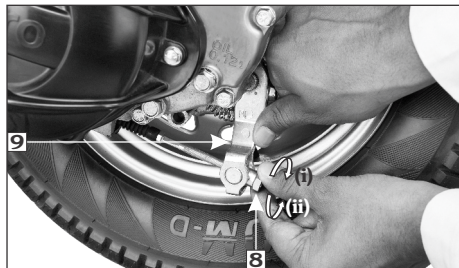

(8) Adjuster nut

(9) Brake arm

(i) Decrease free play (ii) Increase free play

Make sure the cut-out on the adjusting nut (1) is seated on the brake joint pin (2) after making final freeplay adjustment.

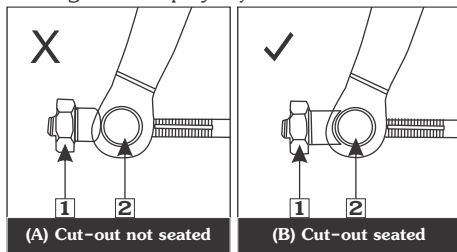

(1) Adjusting nut

(2) Brake joint pin

If proper adjustment cannot be obtained by this method, visit your Authorised Hero MotoCorp workshop.

Other checks:

Check brake cable for kinks or signs of wear that could cause sticking or failure.

Make sure the brake arm spring and fasteners are in good condition.

NOTE

Apply the brake several times and check for free wheel rotation after the brake lever is released.

FUEL

Fuel tank

The fuel tank is located under the seat.

The fuel tank capacity is **5.5 litres (minimum)**.

To open the fuel filler cap (1), insert the ignition key (2), push it in and turn the ignition key to fuel open or in clockwise

position (page 24) the lid will open as shown in the picture.

Lift the fuel filler cap by hand while refuelling.

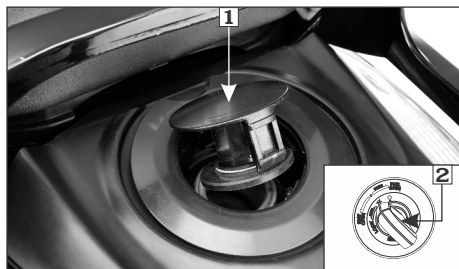

(1) Fuel filler cap

(2) Ignition Key

Do not overfill the tank. There should be no fuel (4) in the filler neck (3).

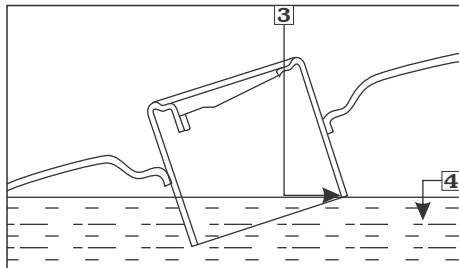

(3) Filler neck

(4) Fuel

After refuelling, press the lid gently for locking until a click sound is heard.

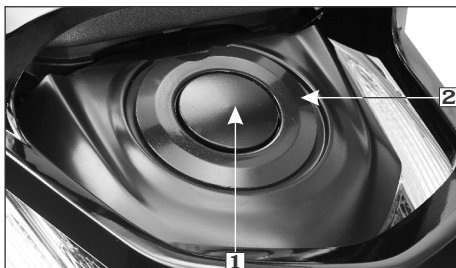

(1) Fuel filler cap

(2) Fuel tank assembly

We recommend that you use unleaded petrol because the muffler in the scooter is fitted with a catalytic convertor, it also produces lesser deposits in engine and on spark plug, which extends the life of exhaust system and other components.

NOTE

If "Spark knock" or "pinking" occurs at a steady engine speed under normal load, change petrol brand. If the same still persists, consult your Authorised Hero MotoCorp workshop. Failure to do so is considered misuse, and damage caused by misuse is not covered under Hero MotoCorp warranty policy.

WARNING

- ▶ After filling petrol, if the fuel filler cap is not closed and remain open, and the ignition switch is turned to "ON" position, a warning buzzer will sound till either the fuel filler cap is shut/closed, or the ignition switch is turned "OFF" condition.
- ▶ Buzzer will also sound till the ignition switch is turned "OFF" too, apart from shut/closure of fuel filler cap

Petrol containing alcohol

If you decide to use a petrol containing alcohol (gasohol), be sure its octane rating is at least as high as that recommended by Hero MotoCorp. There are two types of "gasohol", one containing ethanol, and the other containing methanol.

Do not use petrol containing methanol (methyl or wood alcohol) that does not contain cosolvents and corrosion inhibitors for methanol.

Never use petrol containing more than 5% methanol, even if it has cosolvents and corrosion inhibitors.

- ▶ When certain type of petrol containing alcohols are used, problems such as hard starting, poor performance, etc. may occur.
- ▶ If you notice any undesirable operating symptoms while using the petrol that contains alcohol, try another station or switch to another brand of petrol.
- ▶ When a problem resulting from the use of petrol containing alcohol occurs, contact your Authorised Hero MotoCorp workshop.

CAUTION

When the fuel level indicator displays the last segment in the fuel gauge, the fuel quantity in the fuel tank is low. Please fill petrol once the fuel level indicator reaches the last segment.

WARNING

Petrol is highly flammable and explosive. You can be burned or seriously injured when handling fuel.

- ▶ ***Stop the engine and keep heat, sparks and flame away.***
- ▶ ***Refuel only outdoors.***
- ▶ ***Wipe off spills immediately.***

TYRES (TUBELESS)

The tyres fitted on your scooter are of TUBELESS type.

To safely operate your scooter, your tyres must be of the proper type and size in good condition with adequate tread and correctly inflated for the load you are carrying. The following pages give more detailed information on how and when to check the air pressure, how to inspect your tyres for damage and what to do when your tyres need to be repaired or replaced.

WARNING

- ▶ ***Riding on tyres that are excessively worn or improperly inflated can cause a crash in which you can be seriously hurt or killed.***
- ▶ ***Follow all instructions in this owner's manual regarding tyres inflation and maintenance.***

Air pressure

Keeping your tyres properly inflated provides the best combination of handling, tread life and riding comfort. Generally, under-inflated tyres wear unevenly, adversely affect handling and are more likely to fail from being overheated.

Over-inflated tyres make your scooter ride harshly are more prone to damage from road hazards and wear unevenly.

We recommend that you visually check your tyres before every ride and use a gauge to measure air pressure at least once a month or any time you think the tyre pressure might be low. Tubeless tyres have some self-sealing ability if they are punctured. However, because

leakage is often very slow, you should look closely for punctures whenever a tyre is not fully inflated.

Always check air pressure when your tyres are "cold"—when the scooter has been parked for at least three hours. If you check air pressure when your tyres are "warm"—when the scooter has been ridden for even a few km—the readings will be higher than if the tyres were "cold". This is normal, so do not let air out of the tyres to match the recommended cold air pressures given below. If you do, the tyres will be under-inflated.

The recommended "cold" tyre pressures are:

	Rider only	Rider and Pillion
Front	1.50 kgf/cm ² (22 psi)	1.50 kgf/cm ² (22 psi)
Rear	2.00 kgf/cm ² (29 psi)	2.50 kgf/cm ² (36 psi)



(1) Air pressure gauge

CAUTION

Over inflation/Under inflation will affect the performance.

Inspection

Whenever you check the tyre pressure, you should also examine tyre treads & side walls for wear, damage & foreign objects.

Look for:

- ▶ Bumps or bulges in the side of the tyre or the tread. Replace the tyre if you find any bumps or bulges.
- ▶ Cuts, splits or cracks in the tyre. Replace the tyre if you can see fabric or cord.

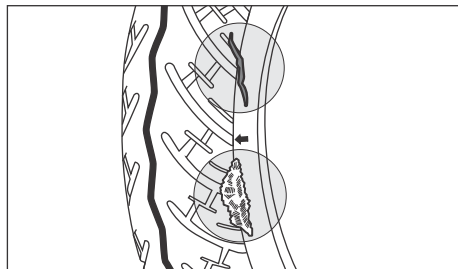

- ▶ Excessive tread wear.

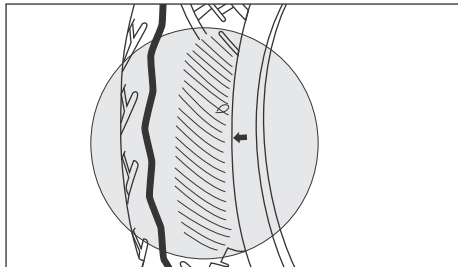

► Carefully inspect the tyres for any damage, if the scooter hits a pothole or hard object.

Tread wear

Replace tyres immediately when the wear indicator (1) appears on the tyre. The tread limits are :

Minimum tread depth:

Front: 1.5 mm

Rear: 1.5 mm

Check the tread wear indicator for tyre wear.



(1) Tyre wear indicator (2) Arrow mark

Unidirectional tyres

Whenever the tyre is removed and put back in case of puncture, ensure the arrow mark (2) on the tyre is in the same direction as that of forward rotation of wheel.

Tyre repair

Repairing a puncture or removing a wheel requires special tools and technical expertise. If a tyre is punctured or damaged, it is advised to visit nearest tyre manufacture, Hero MotoCorp authorised dealer/workshop or the

tyre repair shop who has expertise in repairing methods of tubeless tyre.

A tyre that is repaired either temporarily or permanently, will have lower speed and performance limits than a new tyre. After an emergency repair, always have the tyre inspected/replaced at our authorised dealer and replace the tyre if suggested.

You should not exceed 70 km/hour for the 1st 24 hours or 105 km/hour at any time thereafter. In addition, you may not be able to safely carry as much load as with a new tyre.

If you decide to have a tyre replace be sure the wheel is balanced before you ride.

Tyre replacement

The tyres that were installed on your scooter were designed to match the performance capabilities of your scooter and provide the best combination of handling, braking, durability and comfort.

NOTE

The imported tyre(s) if fitted without ISI mark; are in compliance of BIS standard and Central Motor Vehicle Rules 1989, as declared by the Tyre manufacturer.

WARNING

- *Riding on tyres that are excessively worn or improperly inflated can cause a crash in which you can be seriously hurt and killed.*
- *Operation with excessively worn tyres is hazardous and will adversely affect traction and handling.*
- *Follow all instruction in this owner's manual regarding tyre inflation and maintenance.*
- *Under-inflation may result in the tyre slipping on or tyre coming off the rim.*
- *Always use the size and type of tyres recommended in this owner's manual.*

The recommended tyre for your scooter are:
Front : 90/100x10-53J (Tubeless Tyre)
Rear : 90/100x10-53J (Tubeless Tyre)

NOTE

For repair and replacement of tyre it is advised to visit your Authorised Hero MotoCorp workshop.

Important safety reminders

- Do not install a tube inside a tubeless tyre on this scooter. Excessive heat buildup can cause the tube to burst.
- Use only tubeless tyres on this scooter. The rims are designed for tubeless tyres and during hard acceleration or braking, a tube-type tyre could slip on the rim and cause the tyre to rapidly deflate.

ESSENTIAL INDIVIDUAL COMPONENTS IGNITION SWITCH

The ignition switch (1) is on the right side below the steering.

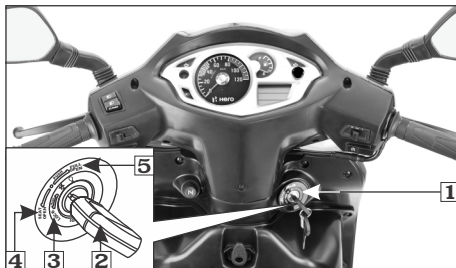

- (1) Ignition switch
- (2) Ignition key
- (3) Steering lock position
- (4) Seat open
- (5) Fuel open

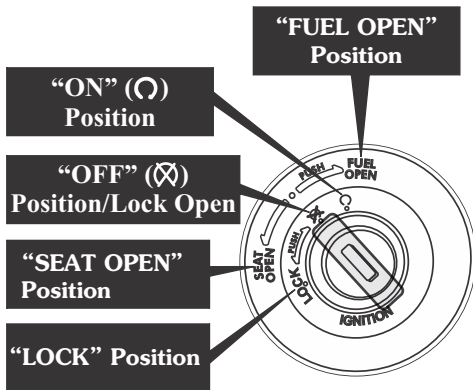

Key Position	Function	Key removal
“ON” (⊙)	The engine can be started, turn signal lamps, horn, stop lamp and fuel gauge can be operated	Key cannot be removed
“OFF” (⊗)	Engine cannot be started and cannot be operated	Key can be removed
“LOCK”	Steering can be locked	Key can be removed
“SEAT OPEN”	Seat can be opened by rotating the key anticlockwise.	Key can be removed
“FUEL OPEN”	Fuel filler cap can be opened by pushing the key inwards and rotating it into the clockwise direction	Key can be removed

RIGHT HANDLEBAR CONTROLS

1. Headlamp switch

The switch has two positions.

“☼”, “☼” and “●” marked by Red dot.

Position	Action
●	“OFF”
☼	“Following is “ON” ▷ Position lamp ▷ Tail/Stop lamp ▷ Fuel gauge lamp ▷ Speedometer lamp
☼	Headlamp “ON”

The Headlamp operates only when the engine is running.

2. Starter switch (⊕)

The starter switch (2) is next to the throttle grip.

When the starter switch is pressed, the starter motor cranks the engine. See (page 38) for the starting procedure.



(1) Headlamp switch

(2) Starter switch

LEFT HANDLEBAR CONTROLS

1. Dimmer switch/Passing switch (For VX model only)

Press the switch upwards for High Beam “☼” and downwards for Low Beam “☼”. Press the switch to pass lamp position to operate the pass lamp.

2. Turn signal switch (↔)

Shift the turn signal switch sideways for Right/Left indications and leave it to come back to its normal position on its own.

IMPORTANT: To switch “OFF” the turn signal after completing the turn, gently push inside as directed on the switch.

3. Horn switch (📢)

Press the switch to operate the horn.



(1) Dimmer switch/Passing switch (For VX model only) (2) Turn signal switch
(3) Horn switch

FEATURES

STEERING LOCK

To lock the steering, turn the handle bar all the way to the left, turn the key (1) to "LOCK" position while pushing in and remove the key.



(1) Ignition switch (A) Push in (B) Turn to lock

⚠ CAUTION

Do not try to turn the key to "LOCK" position while riding the scooter, which may lead to loss of vehicle control.

FUEL FILLER CAP/LOCK

The fuel filler cap lock is provided with ignition switch (1).

To open the filler cap, insert the key (2) while pushing in and turn it clockwise to "Fuel Open" position. The filler cap will release from its latch. To lock the filler cap push down gently until it locks and hear a click sound to ensure the fuel filler cap is secure before riding.

⚠ CAUTION

Gently close the filler cap by hand. Sudden dropping of the filler cap may result in breaking the filler cap lock and malfunction of the lock.

SEAT LOCK

The seat lock is provided along with the ignition switch (1).

To lift the seat, insert the key (2) and turn it anti-clockwise to unlock the seat. The seat will release from its catch.

To lock the seat, push down until it locks. Make sure the seat is secure before riding.



(1) Ignition switch (2) Ignition key

⚠ CAUTION

Gently close the seat by hand. Sudden dropping of the seat may result in breaking the seat lock and malfunction of the lock.

HELMET HOLDER

Two helmet holders are located under the seat.

To access the holder or to secure a helmet to the holder.

- Open the seat.
- Attach/Hook the helmet strap or ring to the helmet holder and close the seat.
- To release the helmet from the holder.
- Open the seat.
- Remove the helmet from the holder and close the seat.

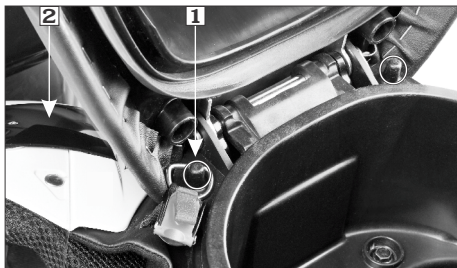

(1) Helmet holder

(2) Helmet

⚠ WARNING

- ▶ *Riding with a helmet attached to the holder can interfere with the objects and could cause a loss of control/crash in which you can be seriously hurt.*
- ▶ *Use the helmet holder only while parked. Do not ride with a helmet secured by the holder.*

📖 NOTE

Place the helmet inside the luggage compartment if you wish to carry along with the vehicle.

CENTER COMPARTMENT

The center compartment (1) is below the seat. A boot lamp (2) is provided in the center compartment. This boot lamp will be functional only when the seat is open.

Opening and closing the Seat Lock, see (page 26).

MAXIMUM WEIGHT LIMIT: 10 kg

Never exceed the maximum weight limit, handling and stability may be severely affected. The center compartment may

become heated by the engine. Do not store food and other articles which are flammable or susceptible to heat damage.

Do not direct pressurised water spray against the center compartment as water may enter into the compartment.

DOCUMENT COMPARTMENT / FIRST AID KIT HOLDER

The document compartment (2) and first aid kit/tool kit holder (5) is located in the center compartment below the seat.

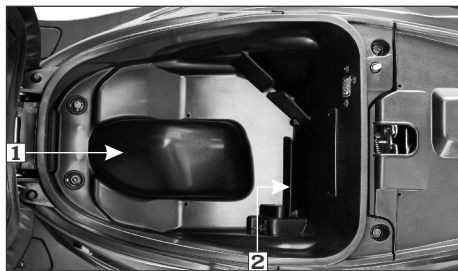

(1) Center compartment

(2) Document compartment

The owner's manual, other documents, first aid kit/tool kit can be stored in it.

📖 NOTE

When washing your scooter, be careful not to flood this area with water.



(5) First aid kit/Tool kit holder

⚠ CAUTION

Before the vehicle is pressure washed the items kept inside the center compartment should be removed to prevent consequential damage.

BOOT LAMP

A boot lamp (1) is provided in the center compartment. This boot lamp will be functional only when the seat is open. For opening and closing the Seat Lock, see (page 26).

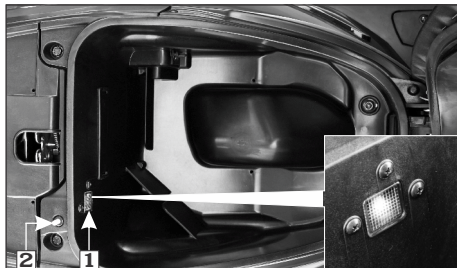

(1) Boot lamp

(2) Switch

BOOT LAMP SWITCH

An automated switch (2) is provided on the center compartment, which enables the boot lamp to glow when the seat is in open condition and goes off automatically when the seat is closed.

USB CHARGER

An USB charger (1) with a cap (2) located inside the center compartment (3) is provided in your scooter to charge your mobile phone safely while riding.

To connect a mobile phone charger cable, first remove the cap from the USB charger and then plug in the charging cable to it.

Use of non standard cable may cause damage to the mobile phones. Hero MotoCorp will not be responsible for damages caused due to use of non standard USB cable.

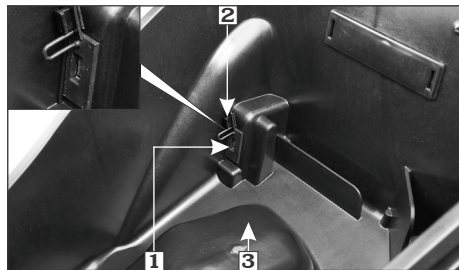

(1) USB charger

(2) Cap

(3) Center compartment

⚠ CAUTION

- › Always place the device in a soft clean cloth/towel to avoid any damage due to road shocks while riding.
- › This port is for charging compatible USB devices.
- › Multiple charging of USB devices have to be avoided, simultaneous charging may lead to slow or no charging.
- › Do not leave the USB device and USB cable in the center compartment when the scooter is parked.
- › Charge your device only when the engine is operational/while riding. Charging the USB device when the engine is "OFF" would lead to early discharge of battery.

🔧 NOTE

- › Do not apply any soap solution, oil or grease inside the mobile charging port.
- › Any personal belongings have to be removed before water washing to avoid damage.
- › Always keep the USB port cap closed after use to prevent dust or water entry during rains/water wash.
- › Do not direct water jet towards the port even with cap closed to avoid any short circuit. Always dry the area using a dry cloth or moisture free compressed air before use.

LUGGAGE HOOK

Two luggage hooks are provided in your scooter to carry a light luggage like shopping bags or carry bags.

One hook is provided below the handle bar.

MAXIMUM WEIGHT LIMIT: 3 Kgs

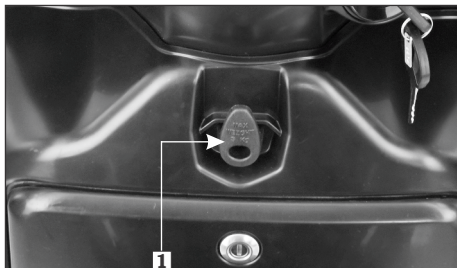

(1) Luggage hook

The other hook (Rear luggage hook) is located below the front end of the seat (**for VX model only**). To use the hook, push the hook in the downward direction as shown to carry the luggage.



(2) Rear luggage hook

Push back the hook to its original position after use as shown below.

MAXIMUM WEIGHT LIMIT: 3 Kgs



(2) Lock seat hook assly.

⚠ WARNING

- Do not exceed the maximum weight limits for the luggage hooks.
- Do not hang large luggage to the hook that would hang out from the scooter and or interfere with the movement of your feet.

FRONT INNER BOX

The front inner box (1) is provided on the inner cover to carry some valuable items, documents, etc.

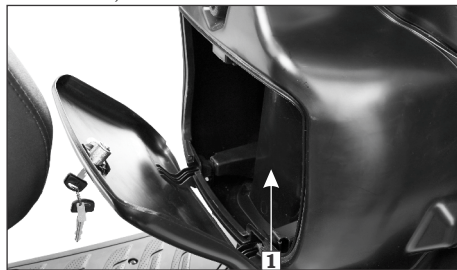

(1) Front inner box

MAXIMUM WEIGHT LIMIT: 1.5 kg

Never exceed the maximum weight limit of the front inner box otherwise handling and stability may be severely affected.

SIDE STAND INDICATOR

For the safety of the customer a side stand indicator (1) is provided. If the side stand is down (Ignition switch “ON”), an indicator lamp glows in the speedometer panel.



(1) Side stand indicator (for VX model)



(1) Side stand indicator (for LX model)

SIDE STAND SWITCH/SIDE STAND

A side stand switch (2) is provided in the side stand, when the side stand is down (Ignition Switch "ON" (O)), the switch enables the side stand indicator lamp to glow on the speedometer panel.

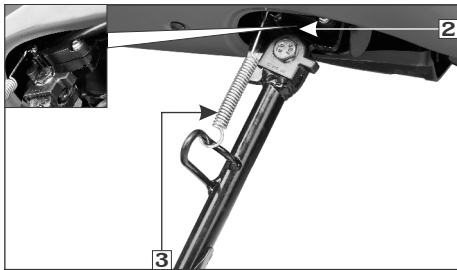

(2) Side stand switch (3) Side stand spring

- ▶ Check the side stand for proper function and the spring (3) for damage or loss of tension and the side stand assembly for free movement.
- ▶ Check whether the side stand indicator (1) glows when the side stand is down.
- ▶ When the side stand is up, the side stand indicator (1) should not glow.
- ▶ If the side stand indicator (1) does not operate as described in above steps, please visit your Authorised Hero MotoCorp workshop.

⚠ CAUTION

Ensure that adequate care should be taken while cleaning the side stand switch.

PILLION FOOTREST

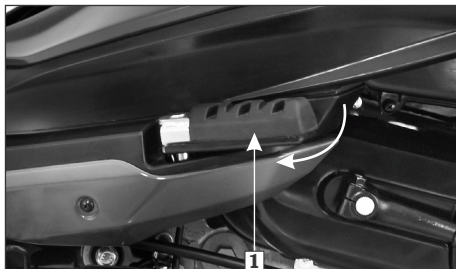

(1) Left footrest

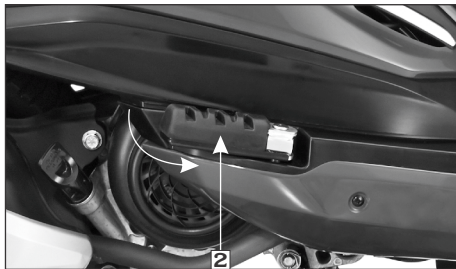

(2) Right footrest

Move the right and left footrest in the direction shown by arrows to open. Folding can be done by moving footrest in the reverse direction.

BODY PARTS REMOVAL

Center compartment (Removal)

- ▶ Open the seat (**page 26**).
- ▶ Remove the bolts (1) from the center compartment.



(1) Bolts

- ▶ Slightly lift up the center compartment from the rear and disconnect the boot lamp connector (2) and USB charger connector (3).

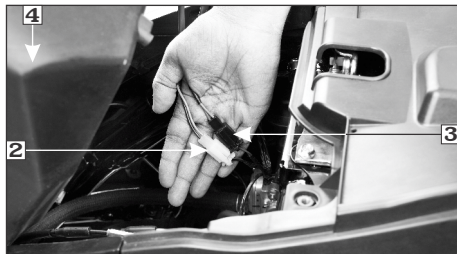

(2) Boot lamp connector
(3) USB charger connector
(4) Center compartment

- ▶ Remove the center compartment (4).

Installation

Installation can be done in the reverse order of removal.

NOTE

Park the scooter on its main stand when servicing the scooter with the center compartment removed.

Center cover (Removal)

Remove screws 4nos. from the center cover.

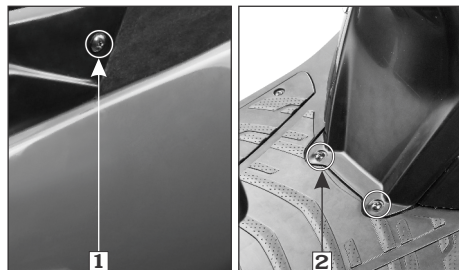

(1) & (2) Screws

Installation

Installation can be done in the reverse order of removal.

Body cover (Removal)

- ▶ Remove the center compartment.
- ▶ Remove the tray fuel sub assy. bolt (1).

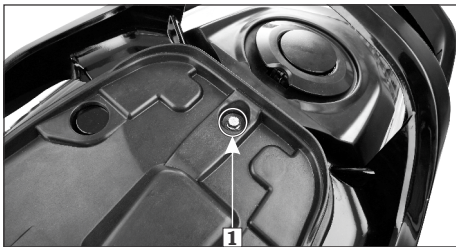

(1) Bolt

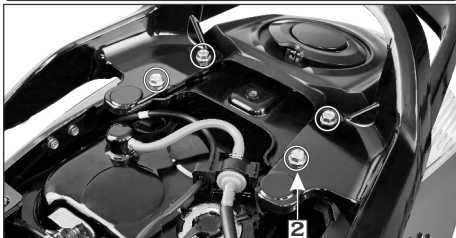

(2) Bolts

- ▶ Remove the rear grip bolts (2).

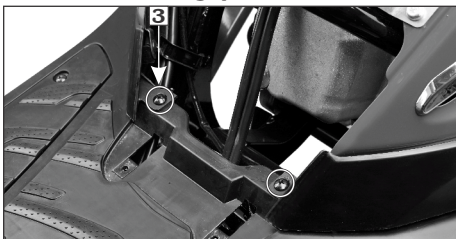

(3) Screws

- ▶ Remove the screws (3).
- ▶ Remove the allen bolts (4) from the fuel lid cover.

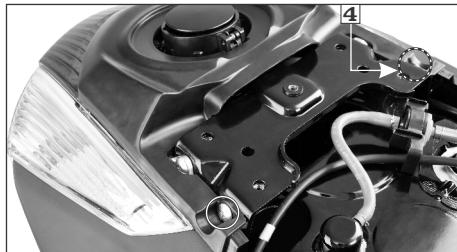

(4) Fuel lid cover allen bolts

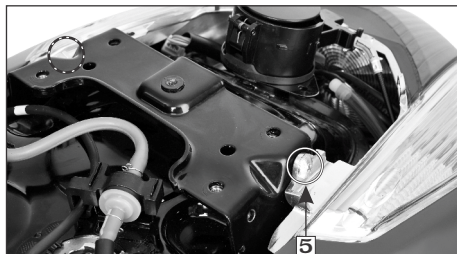

(5) Body cover bolts

- ▶ Remove the body cover bolts (5).
- ▶ Remove the center cover.

- ▷ Disconnect the tail/stop lamp connector (6).

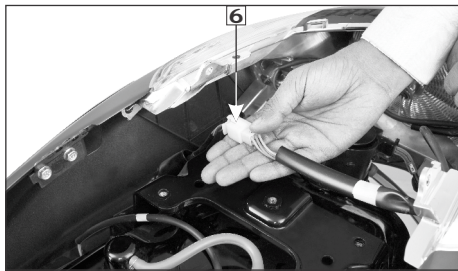

(6) Tail/stop lamp connector

- ▷ Pull the body cover (7) by lifting it from the front and pulling out towards the rear.



(7) Body cover

Remove the complete body cover.

Installation

Installation can be done in the reverse order of removal.

Front Center Cover (Removal)

- ▷ Remove the two screws (1) on the inner cover side.

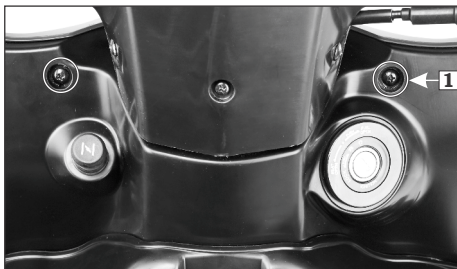

(1) Screws

- ▷ Remove the screw (2) near the front fender.

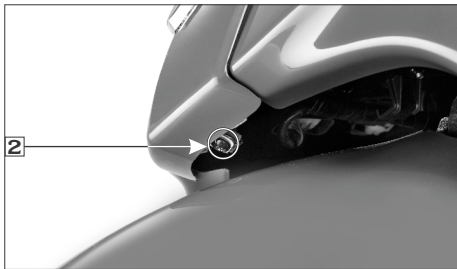

(2) Screw

Release the front center cover lugs from the grommets (3) and pull it in slightly upwards direction to remove it.



(3) Grommets

Installation:

Installation is in the reverse order of removal.

Front Cover (Removal)

- Remove the front center cover (page 34).
- Remove the screws from the front inner box side and from the inner side of the box.



(1) Screws

- Remove the screws (2) from both the front end of the scooter

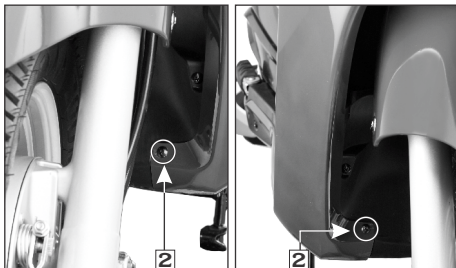

(2) Screws

- Remove mounting bolts (3) and screws/washers(4).

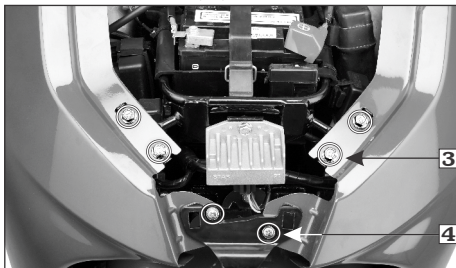

(3) Mounting bolts (4) Screws/washers

- Remove the front cover.

Installation:

Installation is in the reverse order of removal.

Rear view mirror (Black variant for LX model)



(1) Dust cover (2) Lock nut
(3) Rear view mirror

Removal

- Slide the dust cover up (1).
- Loosen the lock nut (2) until it will no longer turn.
- Loosen the rear view mirror (3) and remove it.

Installation

- Install the rear view mirror until it will no longer turn.
- Loosen the rear view mirror approximately 2 turns.
- Adjust the rear view mirror.
- Tighten the lock nut.

NOTE

To open the right side rear view mirror the threads are to be loosened in clockwise direction and tightened in counter clockwise direction.

Headlamp case (Removal)

- Remove the rear view mirror.
- Remove screw (1).

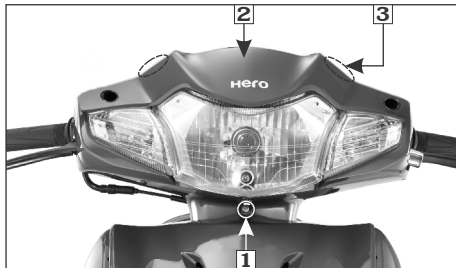

(1) Screw (2) Headlamp case (3) Tabs

- Remove the screws (4).
- Pull the headlamp case (2) slightly up, carefully release the tabs (3) from the slots.
- Disconnect the headlamp connector (5), position lamp connector (6) and remove the headlamp case.



(4) Screws

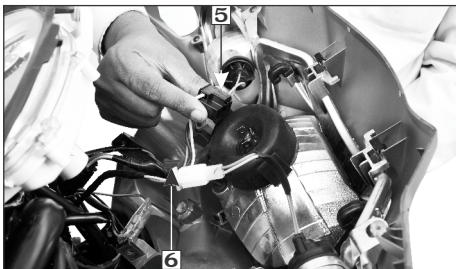

- (5) Headlamp connector
(6) Position lamp connector

Installation

Installation can be done in the reverse order of removal.

Headlamp focus

Vertical adjustment

Headlamp focus is factory preset. However in case of adjustment required please follow the steps as given below.

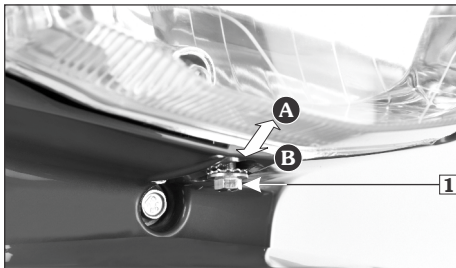

- (1) Bolt (A) Up (B) Down

- Park the scooter on main stand on a level surface in front of a wall.
- Loosen the bolt (1) and move the headlamp up or down for correct focus.

⚠ WARNING

An improperly adjusted headlamp may blind oncoming driver or it may fail to light the road for safe distance.

OPERATIONS

PRE-RIDE INSPECTION

For your safety, it is very important to take a few moments before each ride to walk around your scooter and check its condition. If you detect any problem, be sure you take care of it or have it corrected by your Authorised Hero MotoCorp workshop.

⚠ WARNING

- ***Improper maintenance or failing to correct a problem before riding can cause a crash in which you can be seriously injured.***
- ***Always perform a pre-ride inspection before every ride and correct if any problem.***
- **Engine oil level**—Add engine oil if required (page 53). Check for leaks.
- **Fuel level**—Fill fuel tank when necessary (page 18). Check for leaks.
- **Front and Integrated brake**—Check operation and if necessary, adjust free play (pages 16 to 18).
- **Tyres**—Check condition and pressure (pages 20).

- **Throttle**—Check for smooth opening and full closing in all steering positions.
- **Lamps and horn**—Check that headlamp, tail/stop lamp, turn signal lamps, indicators and horn function properly.
- **Rear view mirrors**—Ensure that the rear view mirrors gives a good view of the rear when you are sitting on the scooter.
- **Fitting & fasteners**—Check & tighten if necessary.
- **Steering**—Check for smooth action for easy maneuverability.
- **Air suction valve**—Make sure all tube connections are secured properly (**page 67**).
- **Side stand indicator**—Make sure that the side stand is up. If it is in down position the side stand indicator (**page 30 & 31**) will glow on the speedometer panel.

ANTI-THEFT TIPS

- **Always lock the steering and never leave the key in the ignition switch.** This sounds simple but people do forget.
- Be sure the registration information for your scooter is accurate and current.
- Park your scooter in a locked garage whenever possible.
- Use an additional anti-theft device of good quality.
- Never park your scooter in an isolated area. Park as far as possible in a designated parking area.

- Enter your name, address, and phone number in this Owner's Manual and keep it in your scooter at all times. Many times stolen scooters are identified by information in the Owner's Manuals that are still with them.

NAME : _____

ADDRESS : _____

PHONE NO : _____

STARTING THE ENGINE

Always follow the proper starting procedure described below. This scooter has an automatic fuel valve and option to fit a side stand and side stand switch.

Operate the kick starter or electric starter switch for slightly longer than usual without opening the throttle if the scooter has been left standing for a long time or when the fuel tank has just been refilled.

NOTE

Do not use the electric starter for more than 5 seconds at a time. Release the starter switch for approximately 10 seconds before pressing it again.

Your scooter's exhaust contains poisonous carbon monoxide gas. High levels of carbon monoxide can collect rapidly in enclosed areas such as a garage. Do not run the engine with the garage door closed.

Even with the door open, run the engine only long enough to move your scooter out of the garage.

⚠ CAUTION

Do not attempt to start the engine and run the vehicle without a battery. This may lead to electrical and electronic components failure.

- ▷ Park the scooter on its main stand.
- ▷ Lock the rear wheel by pressing the integrated brake lever (1) and locking the parking lever (2).



(1) Integrated brake lever (2) Parking lever

The electric starter will only work when the integrated or front brake lever is operated.

⚠ WARNING

- ▷ Contact with the rotating rear wheel can injure you.
- ▷ Set the parking lever when the scooter is on its main stand.

NOTE

The scooter is equipped with Bi-Starter system. Do not accelerate while starting the engine by using an electric starter or kick starter.

- ▷ Turn the ignition switch (3) to "ON".



(3) Ignition Switch

Cold engine

- ▷ Pull the choke knob (4) out all the way to fully "ON" position (A).



(4) Choke knob (A) Fully "ON" (B) Fully "OFF"

- ▶ Use starter switch:
With the throttle closed, press the starter switch.
- Use kick starter:
With the throttle closed, operate the kick starter with a rapid and continuous motion.
- ▶ Continue warming up the engine until it runs smoothly and responds to the throttle, when the choke knob is at "OFF" position (B).

Warm engine

- ▶ Do not use the choke.
- ▶ Rotate the throttle $1/8$ - $1/4$ turn (C).
- ▶ Start the engine.

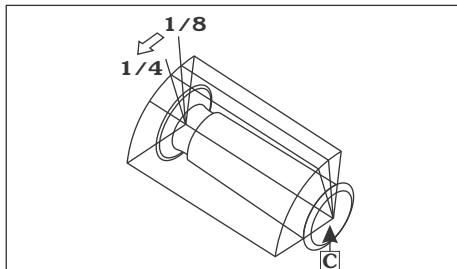

RUNNING-IN

Ensure your scooter's future reliability and performance by paying extra attention to how you ride during the first 500 km. During this period, avoid full-throttle starts and rapid acceleration.

RIDING

Review Scooter Safety (pages 4 to 8) before you ride.

- ▶ **Make sure the throttle is closed and the integrated brake is locked** before moving the scooter off the main stand. The rear wheel must be locked when moving the scooter off the main stand or it may result in loss of control.
- ▶ **Stand on the left side of the scooter** and push it forward off the main stand gripping below the seat using the right hand as shown.

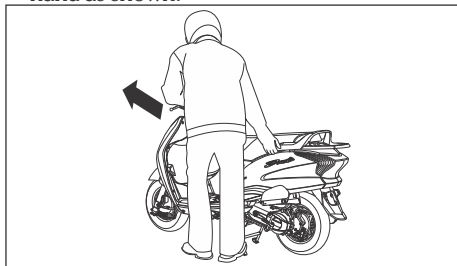

- ▶ **Mount the scooter from the left side** keeping at least one foot on the ground to steady the scooter.

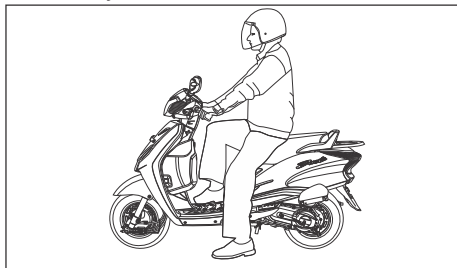

- ▷ **Unlock the integrated brake** by further pressing the integrated brake lever (1) so as to release the parking lever (2) from the lock. Then release the brake lever.

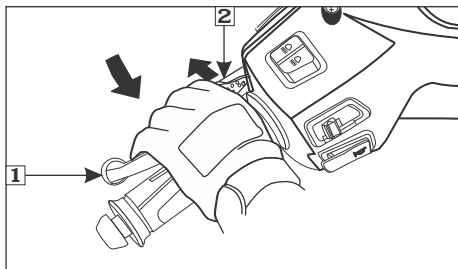

(1) Integrated brake lever (2) Parking lever

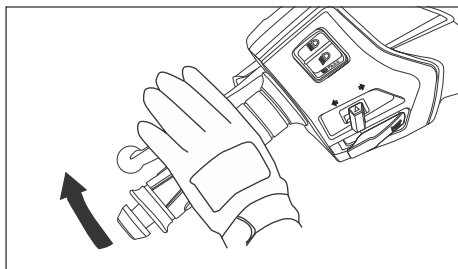

- ▷ **Before starting**, indicate your direction with the turn signals, and check for safe traffic conditions. Grab the handle bars firmly with both hands. Never attempt one-handed operation, this could lead to loss of vehicle control.

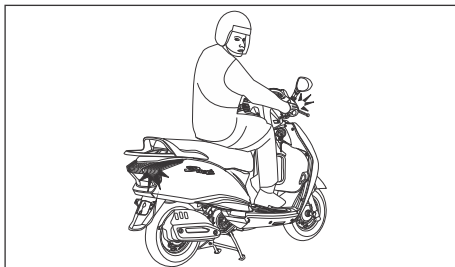

- ▷ **To accelerate**, open the throttle (3) gradually, the scooter will move forward. Do not open and close throttle rapidly, as it will make the scooter to move forward suddenly, causing possible loss of control and loss of fuel economy.

Do not accelerate with the brakes applied, this may lead to premature wear of brakes and transmission parts.

- ▷ **To decelerate**, close the throttle.

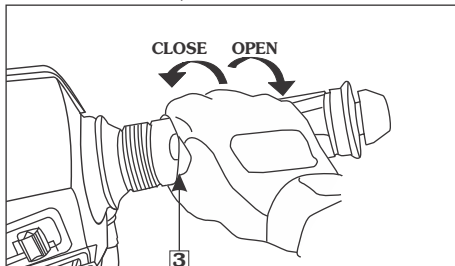

(3) Throttle

► **When slowing down the scooter,**

coordination of the throttle (3), front (4) and integrated brake (5) is most important. Since the scooter is equipped with an integrated braking, by pressing the brake lever provided on the left side of the handlebar would ensure both front and rear brakes applied simultaneously.

Excessive brake application may cause the wheels to lock, reducing control over the scooter.

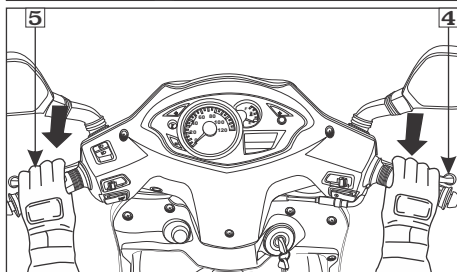
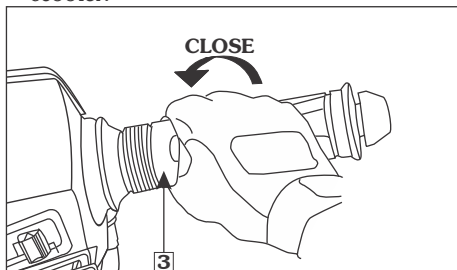

(4) Front brake

(5) Integrated brake

- **When approaching a corner or turn,** close the throttle (3) fully, and slow down the scooter by applying integrated brake (6).
- **After completing the turn,** open the throttle gradually to accelerate the scooter.

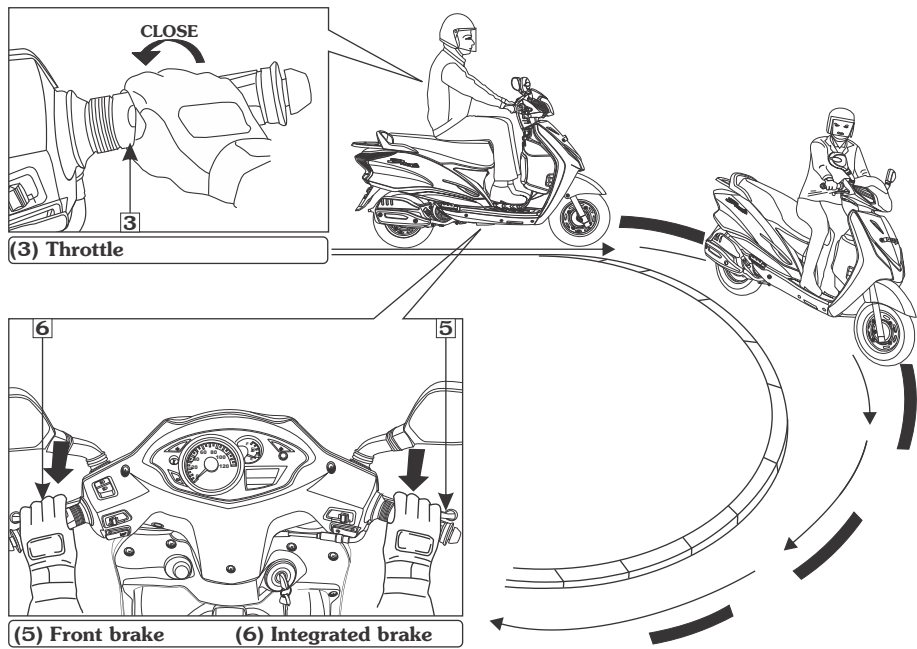

► **When descending a steep gradient,** close throttle (3) fully and apply integrated brake (4) to slow down the scooter.

Avoid continuous use of the brakes, which may result in overheating and reduction of braking efficiency.

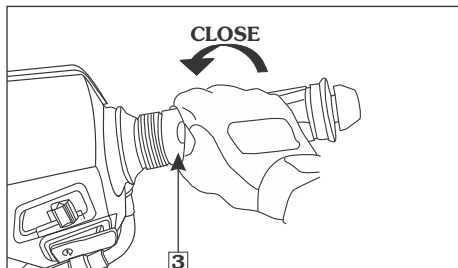

(3) Throttle

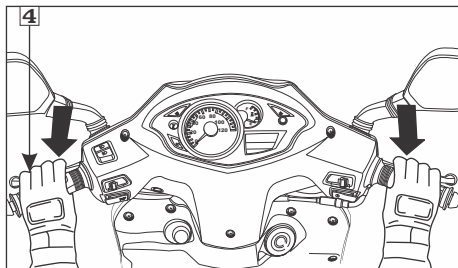

(4) Integrated brake

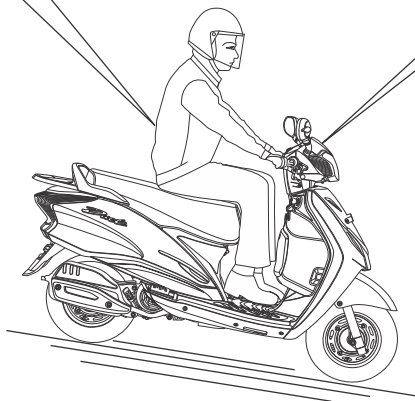

‣ **When riding on wet or loose surfaces, be cautious.**

When riding in wet or rainy conditions or on loose surfaces, the ability to manoeuvre and stop will be reduced.

For your safety:

- Exercise extreme caution when braking, accelerating or turning.
- Ride at slower speeds and allow for extra stopping distance.
- Keep the scooter as upright as possible.
- Be cautious when riding over slippery surfaces such as railway tracks, iron plates, manhole covers, painted lines, etc.

PARKING

- After stopping the scooter turn the ignition switch to "OFF" position.
- Use the main stand to support the scooter while parked, lock and remove the key.

NOTE

- *Park the scooter on firm, level surface to prevent it from falling over.*
- *If you must park on a slight incline, aim the front of the scooter uphill to reduce the possibility of rolling off the main stand or overturning.*

- Lock the steering to prevent theft.

CAUTION

The exhaust pipe and muffler become very hot during operation and remain sufficiently hot to inflict burns if touched even after turning off the engine.

HOW TO USE MAIN STAND

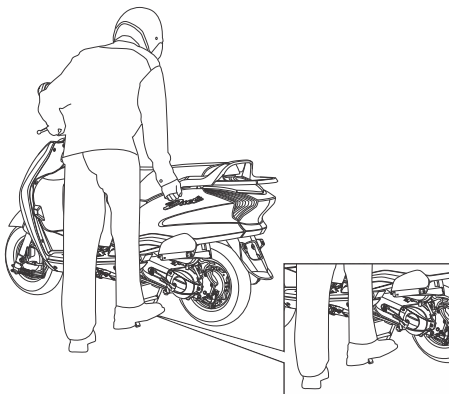

STEERING LOCK

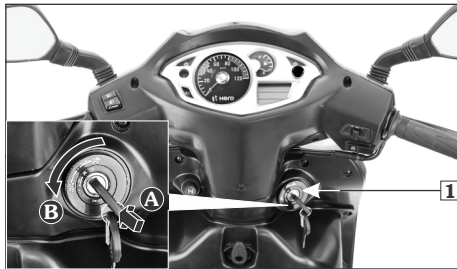

(1) Ignition switch (A) Push in (B) Turn to lock

TOOL KIT/FIRST AID KIT

The tool kit (1) is located in the center compartment (3).

Some roadside repairs, minor adjustments and parts replacement can be performed with the tools available in the kit.

- Tool bag-1 No.
- +-No. 2 driver-1 No.
- Grip-1 No.
- Wrench plug 16-1 No.
- Spanner 14-1 No.



- (1) Tool kit (2) First aid kit
(3) Center compartment

The first aid kit (2) is located in the center compartment (3) along with the toolkit. For some emergency first aid can be performed by medicine available in the kit.

- Antiseptic Cream-1 No.
- Sterilised Dressing-1 No.
- Water Proof Plaster-1 No.
- Elastic Bandage-1 No.
- Gauge (Rolled Bandage)-1 No.
- Sterilised Elastic Plaster-1 No.
- First Aid Bag-1 No.

MAINTENANCE

IMPORTANCE OF MAINTENANCE

A well maintained scooter is essential for safe, economical and trouble free riding. It will also help reduce air pollution.

To help you to take proper care for your scooter, the following pages include a Maintenance Schedule and a Maintenance Record for regular scheduled maintenance.

These instructions are based on the assumption that the scooter will be used exclusively for its designed purpose.

Sustained high speed operation or operation in unusually wet or dusty conditions will require more frequent service than specified in the Maintenance Schedule. Consult your Authorised Hero MotoCorp workshop for recommendations applicable to your individual needs and use.

If your vehicle overturns or is involved in a crash, be sure that you visit your Authorised Hero MotoCorp workshop for detailed inspections.

⚠ WARNING

- ***Improperly maintaining this scooter or failing to correct a problem before you ride can cause an accident in which you can be seriously injured.***
- ***Always follow the inspection and maintenance recommendations and schedules in this owner's manual.***

MAINTENANCE SAFETY

This section includes instructions on some important maintenance tasks. You can perform some of these tasks with the tools provided (if you have basic mechanical skills).

Other tasks that are more difficult and require special toolt is recommended that wheel removal should normally be handled by a Hero MotoCorp authorised workshop.

You will come across some of the most important safety precautions in the following pages of this manual.

However, we cannot warn you of every conceivable hazard that can arise in performing maintenance. Only you can decide whether or not you should perform a given task.

WARNING

- ▷ ***Failure to follow maintenance instructions and precautions properly can seriously injure you.***
- ▷ ***Always follow the procedures and precautions in this owner's manual.***

SAFETY PRECAUTIONS

- ▷ Make sure the engine is turned “OFF” before you begin any maintenance or repair. This will help eliminate several potential hazards:
 - **Carbon monoxide poisoning from engine exhaust.**

Be sure there is adequate ventilation whenever you start the engine.

- **Burns from hot parts.**

Let the engine and exhaust system cool before touching.

- **Injury from moving parts.**

Do not run the engine unless instructed to do so.

- ▷ Read the instructions before you begin and make sure you have the tools and skills required.
- ▷ To prevent the scooter from falling over, park it on a firm, level surface, on the main stand.
- ▷ Be sure that the rear brake is locked by parking lever before running the engine, while the scooter is parked on the main stand. This will prevent the rear wheel from rotating and avoid the possibility of someone being injured from contacting the wheel.
- ▷ To reduce the possibility of a fire or explosion, be careful when working around petrol or batteries. Use only nonflammable solvent, not petrol, to clean parts. Keep cigarettes, sparks and flames away from the battery and all fuel-related parts.

Remember that your Authorised Hero MotoCorp workshop knows your scooter best and is fully equipped to maintain and repair it.

To ensure best quality and reliability, it is recommended to use Hero MotoCorp genuine parts for repair and replacement.

MAINTENANCE SCHEDULE

Perform the Pre-ride Inspection (page 37) at each scheduled maintenance period.

I: INSPECT C: CLEAN R: REPLACE A: ADJUST L: LUBRICATE T: TOP UP

The following Maintenance Schedule specifies all maintenance required to keep your scooter in peak operating condition. Maintenance work should be performed in accordance with standards and specifications of Hero MotoCorp by properly trained and equipped technicians. Your Authorised Hero MotoCorp workshop meets all of these requirements.

Ensure that each paid service is availed within 90 days or 3000 km from the date of previous service, whichever is earlier.

- * Clean carburetor if required after inspection during service.
- ** Should be serviced by a "Skilled Technician" of your Authorised Hero MotoCorp workshop.
- *** In the interest of safety, we recommend these items to be serviced only by your Authorised Hero MotoCorp workshop.
- **** Replace engine oil once in every 6000 km. Top up if the oil level is at or near the lower level mark.
- # Replace drive belt once in every 24000 km.
- Check idle CO emission along with idle r/min/idle CO adjustment (if required).
- @ Replace once in every 12000 km.
- ☞ Check battery voltage (for VX model).
- ☞ Check battery electrolyte level (for LX model).
- ◆ Lubricate the pivot arm (for LX model).

Note-1: At higher odometer readings, repeat the frequency interval established here.

Note-2: More frequent cleaning may be required when riding in dusty area. Replace once in every 12000 km.

Note-3: Service more frequently when riding in rain or at full throttle.

Note-4: Service more frequently if the scooter is ridden in unusually wet or dusty areas.

Note-5: Replace once in every 10000 km or once in a year, whichever is earlier. Replacement requires mechanical skill.

Note-6: Inspect if side stand switch is installed.

Note-7: Replace the front fork oil once in every 2 years or 20000 km, whichever is earlier.

Note-8: Inspect the bearings free play, replace if necessary.

Note-9: Inspect for any play in the mounting bushes, replace if necessary.

MAINTENANCE SCHEDULE

Dear Customer,

We would strongly recommend the following schedule, to keep your scooter in perfect running condition and healthy environment. Scooter subjected to severe use or ridden in dusty area will require more frequent servicing.

ITEMS	WHICHEVER COMES FIRST	DURING FREE SERVICE PERIOD						AFTER FREE SERVICE ONCE IN EVERY					
	SERVICE	1 st	2 nd	3 rd	4 th	5 th	6 th						
	DAYS	1st 60	Next 100	Next 100	Next 100	Next 100	Next 100						
	KM NOTE-1	500-750	3000-3500	6000-6500	9000-9500	12000-12500	15000-15500	3000	6000	9000	12000	15000	
Fuel Lines		I	I	I	I	I	I	I					
Throttle Operation**		I, A	I, A	I, A	I, A	I, A	I, A	I, A					
Fuel Tank Lid Cover Operation**		I, A	I, A	I, A	I, A	I, A	I, A	I, A					
Bystarter Operation**		I, A	I, A	I, A	I, A	I, A	I, A	I, A					
Air Cleaner element	NOTE-2	C	C	C	C	R	C	C				R	
Drain/Crankcase Breather Tube	NOTE-3	I,C	I,C	I,C	I,C	I,C	I,C	I,C					
Spark Plug@		I, C, A	I, C, A	I, C, A	I, C, A	R	I, C, A	I, C, A				R	
Valve Clearance**		I, A	I, A	I, A	I, A	I, A	I, A	I, A					
Engine Oil****		R	T	R	T	R	T	T	R				
Engine Oil Strainer Screen**		C		C		C			C				
Final Drive Oil**	NOTE-5				R								
Engine Idle Speed/Carburetor		I, A	I, A	I, A	I, A	I, A	I, A	I, A					
Secondary Air Injection System				I		I			I				
Secondary Air Cleaner Element	NOTE-4	C	C	C	C	C	C	C					
Brake System		C,L	C,L	C,L	C,L	C,L	C,L	C,L					
Front/Integrated Brake Lever Free Play		I, A	I, A	I, A	I, A	I, A	I, A	I, A					

ITEMS	WHICHEVER COMES FIRST	DURING FREE SERVICE PERIOD						AFTER FREE SERVICE ONCE IN EVERY					
	SERVICE	1 st	2 nd	3 rd	4 th	5 th	6 th						
	DAYS	1st 60	Next 100	Next 100	Next 100	Next 100	Next 100						
	KM NOTE-1	500-750	3000-3500	6000-6500	9000-9500	12000-12500	15000-15500	3000	6000	9000	12000	15000	
Brake Shoe Wear		I	I	I	I	I	I	I					
Pivot Arm *		L	L	L	L	L	L	L					
Parking Lock Operation		I	I	I	I	I	I	I					
Battery Voltage *		I	I	I	I	I	I	I					
Battery Electrolyte *		I,T	I,T	I,T	I,T	I,T	I,T	I,T					
Stop Lamp Switch		I	I	I	I	I	I	I					
Headlamp Focus		I	I	I	I	I	I	I					
Belt Case/Kick Starter Driven Gear		C,L	C,L	C,L	C,L	C,L	C,L	C,L					
Drive Belt**#				I		I			I				
Clutch Shoe Wear***				I		I			I				
Nut, Bolt & Fasteners**		I	I	I	I	I	I	I					
Front Suspension/Oil	NOTE-7	I	I	I	I	I	I	I					
Rear Suspension	NOTE-9	I	I	I	I	I	I	I					
Wheel/Tyres***		I	I	I	I	I	I	I					
Wheel Bearings	NOTE-8	I	I	I	I	I	I	I					
Steering Head Bearings***		I,A	I,A	I,A	I,A	I,L,A	I,A	I,A			I,L,A		
Main Stand		L	L	L	L	L	L	L					
Side Stand (Optional)		L	L	L	L	L	L	L					
Side Stand Switch (Optional)	NOTE-6	I,C	I,C	I,C	I,C	I,C	I,C	I,C					
Muffler (Catalytic Converter) *				I,E		I,E			I,E				

AIR CLEANER

Refer to the safety precautions (page 40).

The air cleaner element is of Dry Paper Pleated type, it should be serviced at regular intervals (page 49). Service more frequently when riding in unusually wet or dusty areas.

- Remove the body cover (page 32 to 35).
- Remove the air cleaner cover (1) by removing the screws (2).

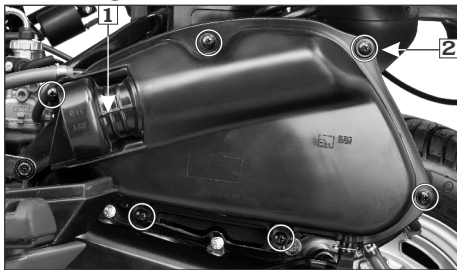

(1) Air cleaner cover (2) Screws

- Remove the air cleaner element screws (3).

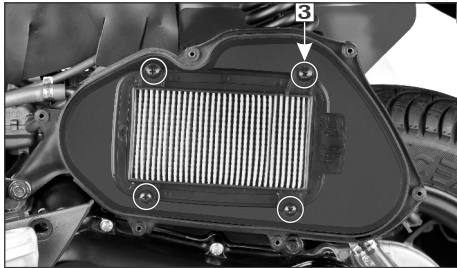

(3) Screws

- Air cleaner element cleaning

- Remove the air cleaner element (4) from housing (5).



(4) Air cleaner element (5) Air cleaner housing

- Clean the element by tapping it gently to loosen dust.
- Blow away the remaining dust by forcing compressed moisture-free air using an air nozzle (6) from the housing side (7) of the air cleaner.
- Replace the air cleaner element if it is excessively dirty, torn or damaged.

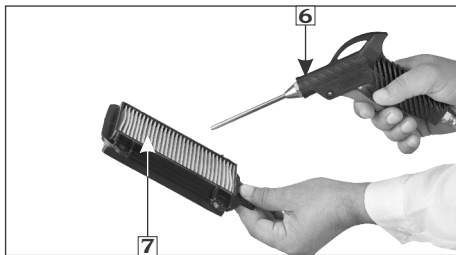

(6) Air nozzle (7) Housing side

- ▶ Install the air cleaner element.
- ▶ Install the removed parts in the reverse order of removal.

⚠ CAUTION

- ▶ **Never wash the air cleaner element. Only blow air in the air cleaner element for cleaning dust, as explained. Replace air cleaner element once in every 12000 km.**
- ▶ **Replace it earlier if it becomes very dirty, damaged on surface or on the sealing area.**

THROTTLE OPERATION

Cable Inspection

Check for smooth rotation of the throttle grip from the fully open to the fully closed position. Check at full left and full right steering positions. Inspect the condition of the throttle cable from the throttle grip down to the carburetor. If the cable is kinked, chafed or improperly routed, it should be replaced or rerouted. Standard throttle grip free play (1) is approximately 2–6 mm of grip rotation.



(1) Free play 2–6 mm

Free Play Adjustment

Slide the grommet (2), loosen the lock nut (3) and turn the adjuster (4).

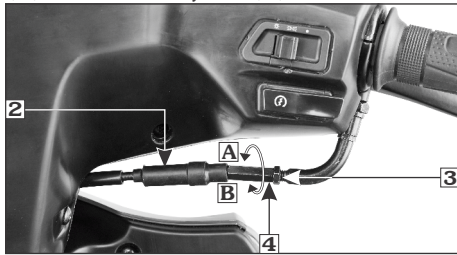

(2) Grommet (3) Lock nut (4) Adjuster
(A) Decrease free play (B) Increase free play

SECONDARY AIR SUPPLY SYSTEM

Refer to the safety precautions (page 45).

Secondary air cleaner element cleaning

The air cleaner element should be serviced at regular intervals (pages 49). Service more frequently when riding in unusually wet or dusty areas.

- ▶ Remove the body cover (page 32 to 35).
- ▶ Remove the air cleaner element housing cover (1) by removing the screw (2).
- ▶ Remove the air cleaner element (3).
- ▶ Wash the air cleaner element in clean, nonflammable or high flash point solvent and let it dry thoroughly.
- ▶ Soak the air cleaner element in gear oil (SAE-90) until saturated, then squeeze out the excess oil.
- ▶ Install the removed parts in the reverse order of removal.

ⓘ CAUTION

Never use gasoline or low flash point solvents for cleaning the air cleaner element. A fire or explosion could result.

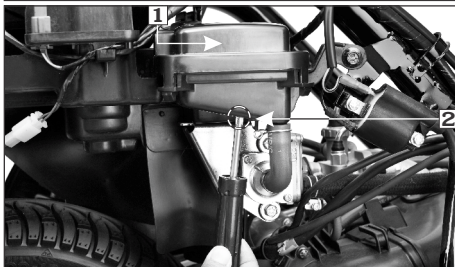

(1) Air cleaner element housing cover (2) Screw

Service more frequently when riding in rain, at full throttle or after the scooter is washed or overturned. Service if the deposit level can be seen in the transparent section of the drain tube.

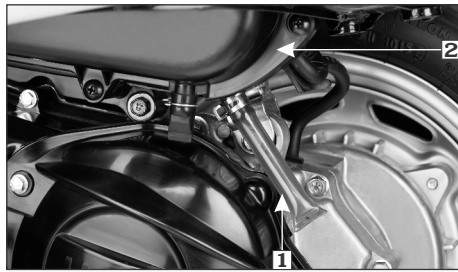

(1) Drain tube (2) Air cleaner assembly

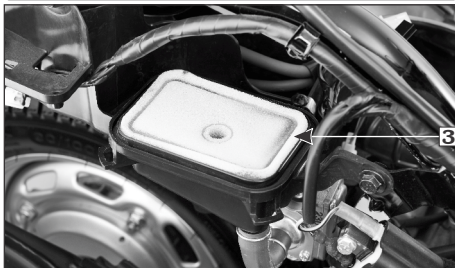

(3) Air filter

ENGINE OIL

Use hero genuine engine oil or recommended grade oil.

BRAND: Hero 4T plus

GRADE: SAE 10W 30 SL Grade

(JASO MB).

Manufactured by:

- ▷ Tide Water Oil Co. (India) Ltd.
- ▷ Savita Oil Technologies Limited.
- ▷ Bharat Petroleum Corporation Limited.

Oil Capacity: 0.8 Litre

Engine oil level check

Check the engine oil level each day before riding the scooter.

The level must be maintained between the UPPER (1) and LOWER (2) level marks on the oil level dipstick (3).

- DRAIN TUBE**
- Refer to the safety precautions (**page 47**).
- ▷ Remove the drain tube (1) from the air cleaner assembly (2) and drain deposits in to a suitable container.
 - ▷ Reinstall the drain tube.

- ▷ Start the engine and let it idle for few minutes.

- Stop the engine and park the scooter on the main stand on a level surface.
- After a few minutes, remove the oil level dipstick, wipe it clean and reinsert the oil level dipstick without screwing it in. Remove the oil level dipstick and check if the oil level is between the upper and lower marks.
- If required, add recommended oil up to the upper level mark. Do not overfill.
- Reinstall the oil level dipstick. Check for oil leaks.
- Remove the oil level dipstick.
- Place an oil drain pan under the crankcase and remove the oil drain bolt (1).

NOTE

- *Running the engine with insufficient oil may cause engine damage.*
- *Top up if required after every 3000 km.*

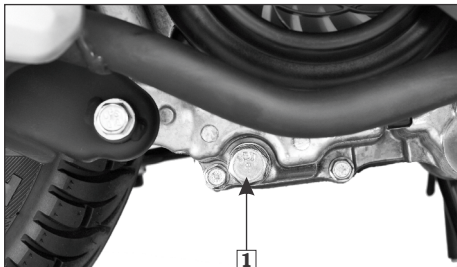

(1) Drain bolt



(1) UPPER level mark (2) LOWER level mark
(3) Oil level dipstick

- Remove the oil strainer screen cap (2).

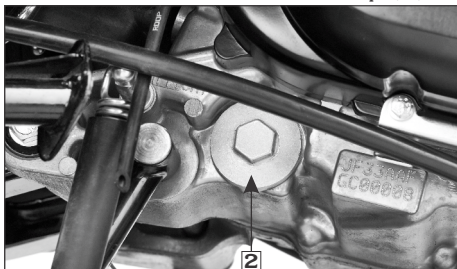

(2) Oil strainer screen cap

Engine oil replacement/Oil strainer cleaning

Change the engine oil with the engine at normal operating temperature and the scooter on its main stand to assure complete and rapid draining.

- The spring (3) and oil strainer screen (4) will come out when the oil strainer screen cap is removed.
- Clean the oil strainer screen.
- Check that the oil strainer screen, sealing

rubber and cap O-ring (5) are in good condition.



(3) Spring (4) Oil strainer screen (5) O-ring

- Install the oil strainer screen, spring and oil strainer screen cap. Install the drain plug.
- Fill crankcase with the recommended grade of oil:

At draining: 0.70 litre

At engine disassembly: 0.80 litre

- Install the oil level dipstick.
- Start the engine and let it idle for 2-3 minutes. Stop the engine and ensure that the oil level is at the upper level mark on the oil level dipstick with the scooter upright on flat level surface. Ensure there are no oil leaks.

⚠ CAUTION

- *Engine oil quality is the chief factor affecting engine service life. Replace and top-up the engine oil as specified in the maintenance schedule (pages 48 to 50).*
- *When running in very dusty conditions, oil changes should be performed more frequently than specified in the maintenance schedule.*

⚠ WARNING

- *Please dispose used engine oil in a manner that is compatible with the environment. We suggest you take it in a sealed container to your local recycling center or service station for reclamation. Do not throw it in the trash or pour it on the ground or down a drain.*
- *Used engine oil may cause skin disease if repeatedly left in contact with the skin for prolonged periods. Although this is unlikely unless you handle used oil on a daily basis, it is still advisable to thoroughly wash your hands with soap and water as soon as possible after handling used oil.*

Final Drive Oil Replacement

The final drive oil should be replaced as per the maintenance schedule. Replacement requires mechanical skill. It is suggested to get it replaced by authorized Hero MotoCorp workshop.

- Park the scooter on its main stand.
- Start the engine and let it idle for 3-5 minutes.
- Stop the engine and wait for 2-3 minutes.



(1) Drain bolt

(2) Check bolt

- Remove the oil level check bolt.
- Remove the drain bolt, slowly turn the rear wheel and drain the oil.
- After the oil is completely drained, install the oil drain bolt with a new sealing washer.
- Fill the transmission case with recommended oil through the check bolt hole up to the bottom edge of the bolt hole.

GRADE : SAE 10W 30 SJ Grade

At draining : 0.10 Litre

At Transmission Disassembly: 0.12 Litre

- Install the oil level check bolt with a new sealing washer and tighten it.

⚠ WARNING

- *While refilling the oil make sure that no foreign material enters the final drive transmission.*
- *Make sure that no oil gets on the tyre or wheel.*

SPARK PLUG

Refer to the safety precautions (page 47).

Recommended spark plug.

Champion-PRZ 9 HC (Federal Mogul)

⚠ WARNING

Never use a spark plug with an improper heat range. Severe engine damage could result.

- Remove the center cover (page 32).
- Disconnect the noise suppressor cap (1) from the spark plug.
- Clean any dirt around the spark plug base.

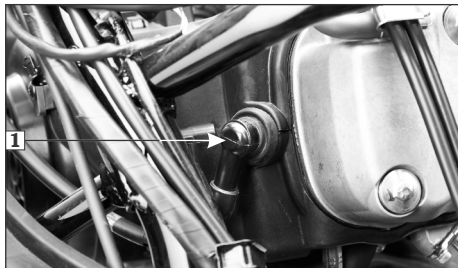

(1) Noise suppressor cap

- Remove the spark plug using the wrench plug provided in the tool kit.
- Inspect the electrodes and center porcelain for deposits, erosion or carbon fouling. If the erosion or deposit is heavy, replace the plug. Clean carbon or wet fouled plug with a plug cleaner.
- Check the spark plug gap using a wire-type feeler gauge. If adjustment is necessary, bend the side electrode (2) carefully.

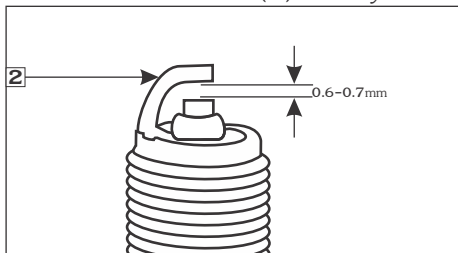

(2) Side electrode

- With the plug washer attached, thread the spark plug in by hand to prevent cross threading.
- Tighten a new spark plug 1/2 turn with a wrench plug to compress the washer. If you are reusing a plug, it should only take 1/8-1/4 turn after the plug seats.
- Reinstall the noise suppressor cap.

⚠ WARNING

The spark plug must be securely tightened. An improperly tightened plug can become very hot and possibly damage the engine.

IDLE SPEED

Refer to the safety precautions (page 47). The engine must be at normal operating temperature for accurate idle speed adjustment. Ten minutes of stop and go riding is sufficient.

- Warm up the engine and park the scooter on its main stand.
- Remove the seat (page 26).
- Remove the body cover (page 32 to 35).

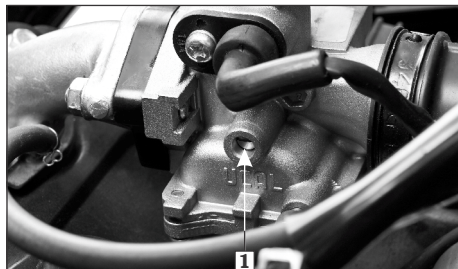

(1) Throttle stop screw

- Adjust idle speed by adjusting the throttle stop screw by inserting a suitable screw driver.

Idle speed: 1500±200 r/min
BRAKE SHOE WEAR

Refer to the safety precautions (page 47).

The front and integrated brakes are equipped with brake wear indicators.

When the brake is applied, an arrow mark (1) on the brake arm (2) moves towards a reference mark (3) on the brake panel (4).

If the arrow aligns with the reference mark on full application of the brake, the brake shoes must be replaced. Visit your Authorised HERO MotoCorp workshop for this service.

Integrated brake (VX/LX model)

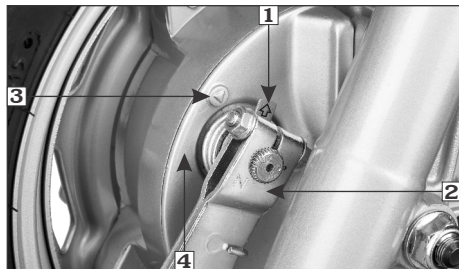

**(1) Arrow (2) Integrated brake arm
 (3) Reference mark (4) Brake panel**

Rear brake

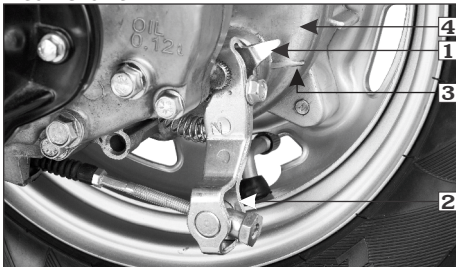

- (1) Arrow
(2) Brake arm
(3) Reference mark
(4) Brake panel

BATTERY (VX model)

Refer to the Safety Precautions (page 47).

Battery is located behind the front center cover.

Specification

*MF Battery 12V-4Ah, ETZ 5

It is not necessary to check the battery electrolyte level or add distilled water as the battery is an **Maintenance Free (sealed)** type. If your battery seems weak and/or electrolyte is leaking (causing hard starting or other electrical troubles), contact your Authorised Hero MotoCorp workshop.

*MF stands for Maintenance Free

NOTE



This symbol on the battery means that this product must not be treated as household waste.



This symbol on the battery means the old battery must be returned to your Authorised Hero MotoCorp workshop as it must be treated as recyclable material.

- ▶ Your battery is a Maintenance Free (sealed) type and can be permanently damaged if the sealing strip is removed.
- ▶ An improperly disposed battery can be harmful to the environment and human health. Always confirm local regulations for battery disposal.

WARNING

- ▶ *The battery gives off explosive hydrogen gas during normal operation.*
- ▶ *A spark or flame can cause the battery to explode with enough force to seriously hurt you.*
- ▶ *Wear protective clothing and a face shield, or have skilled mechanic to do the battery maintenance.*

Battery charging

Always visit your Authorised Hero MotoCorp workshop if you see any symptom of battery discharge as earliest as possible to get the battery charged. The battery has a tendency to discharge rapidly if any additional electrical accessories are fitted on your scooter.

Battery storage

- If in case your scooter is not used for more than a month remove the battery, fully charge and store in a cool and dry place.
- If the battery is expected to be stored for more than two months, ensure to fully charge the battery once in a month.
- Always ensure the battery is fully charged before installation.
- Ensure the battery leads are properly connected to the battery terminals during installation.

Battery Removal

- Remove the front center cover (page 34).
- Remove the battery band (1) by removing the boot band clip (2) from both sides of the battery (2).
- Disconnect the negative (-) terminal lead (3) from the battery first, then disconnect the positive (+) terminal lead (4).
- Remove the battery (5).

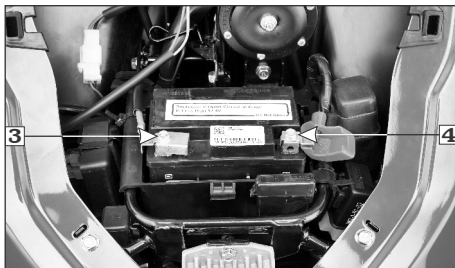

(3) Negative (-) Terminal

(4) Positive (+) Terminal

(5) Battery

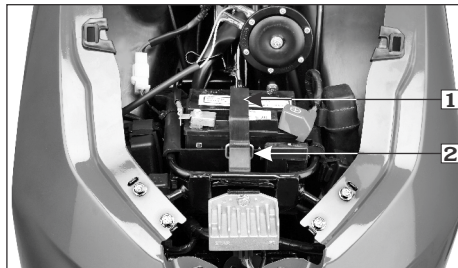

(1) Battery Band

(2) Boot Band clip

Battery installation

- Reinstall in the reverse order of removal. Be sure to connect the positive (+) terminal first, then the negative (-) terminal.
- Check the bolts and other fasteners are secure.

BATTERY (LX model)- Conventional type Location

The battery (1) is located behind the front cover.

Specification: 12V 5 Ah

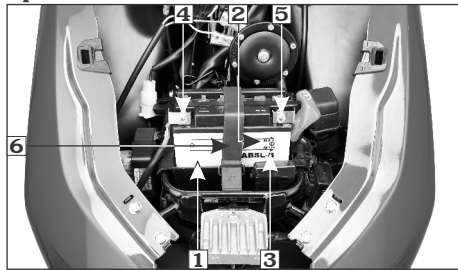

- | | |
|----------------------|----------------------|
| (1) Battery | (2) Upper level mark |
| (3) Lower level mark | (4) (-)ve terminal |
| (5) (+)ve terminal | (6) Battery band |

Maintenance

Check the battery electrolyte. The electrolyte level must be maintained between the upper (2) and the lower (3) level marks on the side of the battery. If the electrolyte level is low, remove battery (1). Remove the battery filler caps.

Carefully add distilled water to the upper level mark using a small plastic funnel.

NOTE

- ▶ Use only distilled water in the battery. Tap water may shorten the service life of the battery.
- ▶ Dispose off used/old battery to authorised dealer only.
- ▶ Insufficient electrolyte results in sulphation & plate damage.

CAUTION

- ▶ When checking battery electrolyte level or adding distilled water, make sure the breather tube is connected to the battery breather outlet.
- ▶ Do not attempt to start or drive the scooter without a charged battery, it can cause fusing of the bulbs and permanent damage to certain electrical components.
- ▶ Turn the ignition switch "OFF" before checking or replacing the fuse to prevent accidental short-circuiting.

Battery Removal

- ▶ Remove the front centre cover (page 34).
- ▶ Remove the battery band (6) by removing the boot band clip.
- ▶ Disconnect the negative (-) terminal lead (3) from the battery first, then disconnect the positive (+) terminal lead (4).
- ▶ Disconnect the battery breather tube (7).
- ▶ Remove the battery (1).

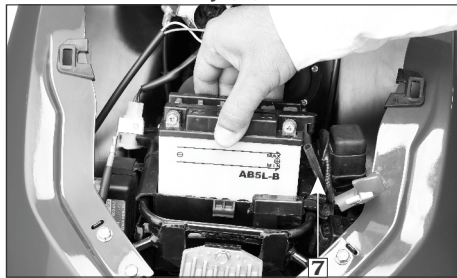

- (7) Battery breather tube

Battery installation

- Reinstall in the reverse order of removal. Be sure to connect the positive (+) terminal first, then the negative (-) terminal.
- Check the bolts and other fasteners are secure.

FUSE REPLACEMENT

The fuse holder (1) placed adjacent to the battery which consists of main fuse and spare fuse.

The specified fuses are 10A

Fuse : Main fuse (2) 10A

Spare fuse (3) 10A

⚠ WARNING

- *Never use a fuse with a different rating from that specified. It may lead to serious damage to the electrical system or a fire due to short circuit.*
- *Battery gives off explosive gases. Keep sparks, flames & cigarettes away.*

(LX model)

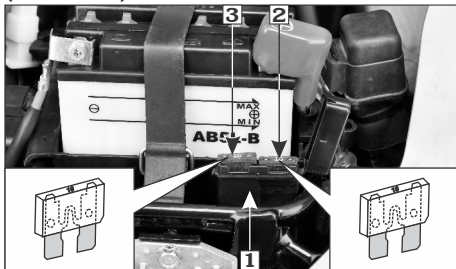

(VX model)

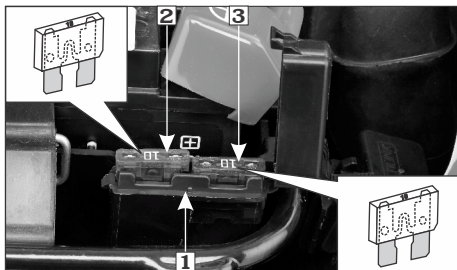

(1) Fuse box

(2) Main fuse 10A

(3) Spare fuse 10A

GOOD FUSE

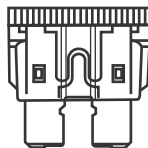

BLOWN FUSE

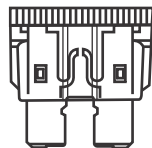

⚠ CAUTION

- *Do not attempt to start or ride the scooter without a charged battery, it can cause fusing of the bulbs and permanent damage to certain electrical components.*
- *Turn the ignition switch "OFF" before checking or replacing the fuse to prevent accidental short-circuiting.*

▷ **If the replacement fuse of the same rating burns out in a short time, there is probably a serious electrical problem on your scooter. Leave the blown fuse in that circuit and have your scooter checked by your Authorised Hero MotoCorp workshop.**

SUSPENSION

Inspection

- ▷ Check the front forks by locking the front brake and pumping the front fork up and down vigorously. The suspension action should be smooth and there should be no oil leakage.
- ▷ Check the rear shock absorber by pushing hard downwards on rear grip while the scooter is not parked on stand. The scooter action should be smooth and there should be no oil leakage.

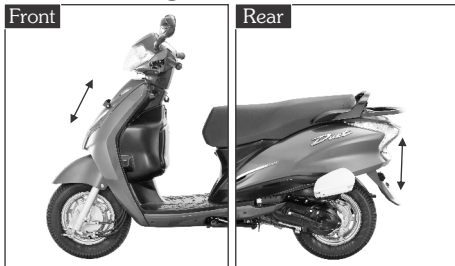

BULB REPLACEMENT

Refer to the Safety Precautions (page 47). The bulb becomes very hot while the lamp is “ON”, and remains hot for a while after it is turned “OFF”. Be sure to let it cool down before servicing.

Do not put finger prints on the headlamp bulb, as they may create hot spots on the bulb and cause it to break.

Wear clean gloves while replacing the bulb. If you touch the bulb with your bare hands, clean it with a cloth moistened with alcohol to prevent its early failure.

- ▷ Be sure to turn the ignition switch “OFF” when replacing the bulb.
- ▷ Do not use bulbs other than that specified.
- ▷ After installing a new bulb, check that the lamp operates properly.

Headlamp/Position lamp bulb

- ▷ Remove the headlamp case (page 36).
- ▷ Disconnect the headlamp connector (1).
- ▷ Remove the dust cover (2).

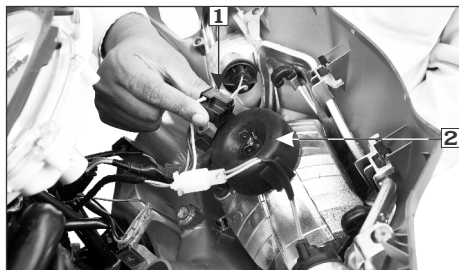

(1) Headlamp connector (2) Dust cover

- ▷ Loosen the screw and release the clip (3) from its position.
- ▷ Remove the headlamp bulb (4) without turning.

- ▶ Remove the position lamp bulb (5) the headlamp case.
- ▶ Install a new bulb in the reverse order of removal.
- ▶ Remove the bulb (5) from bulb holder by pressing in and turning counterclockwise.

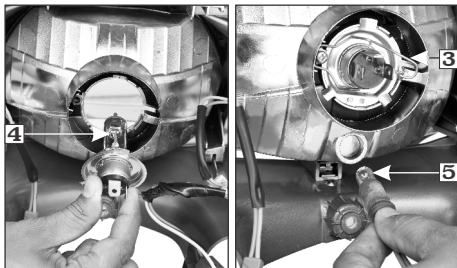

(3) Clip (4) Headlamp bulb (5) Position lamp bulb

Tail/Stop lamp bulb

- ▶ Remove the tail/stop lamp lens from the body cover by removing the cap plugs (1) and the upper screws (2).
- ▶ Remove the bottom screws (3) directly.

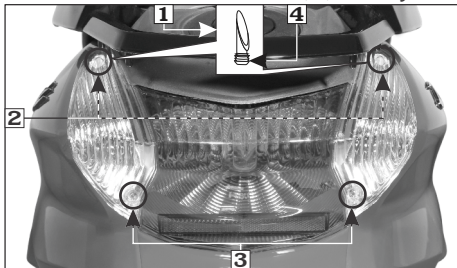

(1) Cap plugs (2) Upper screws (3) Bottom screws (4) Rubber tip

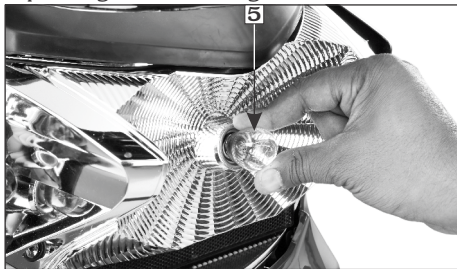

(5) Tail/stop lamp bulb

- ▶ Install a new tail/stop lamp bulb (5) in the reverse order of removal.
- ▶ Install the tail/stop lamp lens and screws. Install the cap plugs with the rubber tip (4) facing inwards in the upper screws boss.

Rear turn signal bulb

- ▶ Follow the above sequence.
- ▶ Remove the bulb (1) from bulb holder by pressing in and turning counterclockwise.

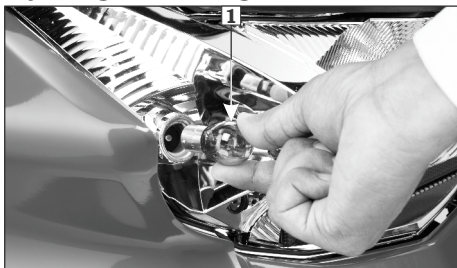

(1) Rear turn signal lamp bulb

- ▶ Install a new bulb and then lens in the reverse order of removal.

Front turn signal bulb

- ▶ Remove the headlamp case (page 36).
- ▶ Remove the bulb (1) by turning it to counterclockwise direction.

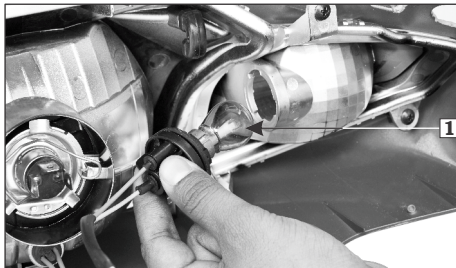

(1) Front turn signal lamp bulb

- ▶ Install a new bulb in the reverse order of removal.

CLEANING

Clean your scooter regularly to protect the surface finishes and inspect for damage, wear and oil leakage.

Avoid cleaning products that are not specifically designed for scooter or automobile surfaces.

They may contain harsh detergents or chemical solvents that could damage the metal, paint and plastic parts on your scooter. If your scooter is still warm from recent operation, give time for the engine and exhaust system to cool down.

We recommend avoiding the use of high pressure water spray.

CAUTION

- ▶ *Our authorised dealership take all above mentioned precautions like recommended detergents and usage of muffler caps/plugs during wash to ensure quality wash.*
- ▶ *High pressure water (or air) can damage certain parts of the scooter.*

WASHING

- ▶ Rinse the scooter thoroughly with water to remove loose dirt.
- ▶ Clean the scooter with a sponge or soft cloth using water.
- ▶ Avoid directing water to muffler outlets and on electrical parts.
- ▶ Clean the plastic parts using a cloth or sponge dampened with a solution of mild detergent and water. Rub the soiled area gently rinsing it frequently with fresh water.

NOTE

- ▶ *Take care to keep brake fluid or chemical solvents off the scooter. They will damage the plastic and painted surfaces.*
- ▶ *The inside of the headlamp lens may be clouded immediately after washing the scooter. Moisture condensation inside the headlamp lens will disappear gradually by lighting the headlamp in high beam.*
- ▶ After cleaning, rinse the scooter thoroughly with plenty of clean water. Strong detergent residue can corrode alloy parts.
- ▶ Dry the scooter with pressurized air, start the engine and let it run for several minutes.

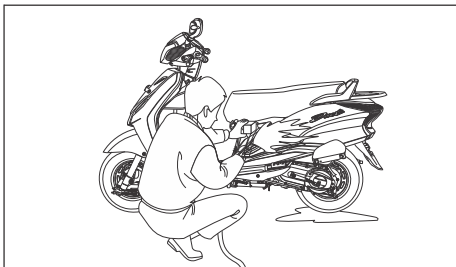

- ▶ Test the brakes before riding the scooter. Several applications may be necessary to restore normal braking performance.

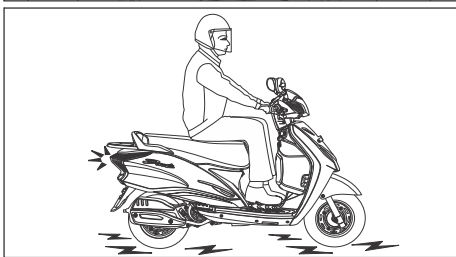
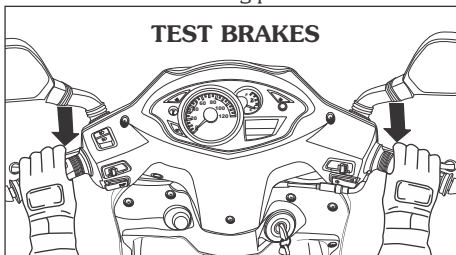

- ▶ Braking efficiency may be temporarily impaired immediately after washing the scooter.

Anticipate longer stopping distance to avoid a possible accident.

POLISHING



NOTE

Polishing or waxing is not applicable for models having matte finish paint.

After washing your scooter, wax all painted surfaces (except matte painted surfaces) using a commercially available polish/quality liquid or paste wax to finish the job. Use only a non abrasive polish or wax made specifically for automobiles. Apply the polish or wax according to the instructions on the container.

Removing Road Salt

The road may contain salt which was sprayed as an anti freezing agent during winter, and the seawater are the causes of rust.

Wash your scooter when run on such conditions by the following the point mentioned below, Clean the scooter using cold water (**page 62**). Do not use warm water. This worsens the effect of the salt.

STORAGE GUIDE

Extended storage, such as for winter, requires that you take certain steps to reduce the effects of deterioration from non use of the scooter. In addition, necessary repairs should be made before storing the scooter, otherwise these repairs may be forgotten by the time the scooter is removed from storage.

STORAGE

- Change the engine oil.
- Empty the fuel tank into an approved petrol container using a commercially available hand siphon or an equivalent method. Spray the inside of the tank with an aerosol rust inhibiting oil.
- Reinstall the fuel filler cap on the tank. If storage lasts more than a month, carburetor draining is very important, to assure proper performance after storage.

WARNING

Petrol is highly flammable and explosive. You can be burned or seriously injured when handling fuel.

- ***Stop the engine and keep heat, sparks, and flame away.***
 - ***Refuel only outdoors.***
 - ***Wipe up spills immediately.***
- To prevent rusting in the cylinder, perform the following:
 - Remove the noise suppressor cap from the spark plug. Using tape or string, secure the cap to any convenient plastic body part so that it is positioned away from the spark plug.
 - Remove the spark plug from the engine and store it in a safe place. Do not connect the spark plug to the noise suppressor cap.
 - Pour a tablespoon (15–20 ml) of clean engine oil into the cylinder and cover the spark plug hole with a piece of cloth.

- Crank the engine several times to distribute the oil.
- Reinstall the spark plug and noise suppressor cap.
- Remove the battery. Store in an area protected from freezing temperatures and direct sunlight. Charge the battery once a month.
- Wash and dry the scooter. Wax all painted surfaces. Coat chrome plated parts with rust inhibiting oil.
- Inflate the tyres to their recommended pressures. Park the scooter on blocks to raise both tyres off the ground.
- Cover the scooter (don't use plastic or other coated materials) and store in an unheated area, free of dampness with a minimum of daily temperature variation. Do not store the scooter in direct sunlight.

REMOVAL FROM STORAGE

- Uncover and clean the scooter. Change the engine oil if the scooter has been stored for more than 4 months.
- Check the battery voltage and charge the battery as required. Install the battery.
- Drain any excess aerosol rust inhibiting oil from the fuel tank. Fill the fuel tank with fresh petrol.
- Perform all Pre-ride Inspection checks (**page 35**). Test ride the scooter at low speeds in a safe riding area away from traffic.

CATALYTIC CONVERTER

This scooter is equipped with a catalytic converter in the muffler.

The catalytic converter contains noble metals that serve as catalyst, promoting chemical reactions to convert CO and HC in the exhaust to CO₂ and H₂O (water vapour). A defective catalytic converter contributes to air pollution and can impair your engine's performance.

Follow these guidelines to protect your scooter catalytic converter.

- ▶ Always use unleaded petrol. Even a small amount of leaded petrol can contaminate the catalyst metals, making the catalytic converter ineffective.
- ▶ Keep the engine tuned up.

AIR SUCTION VALVE

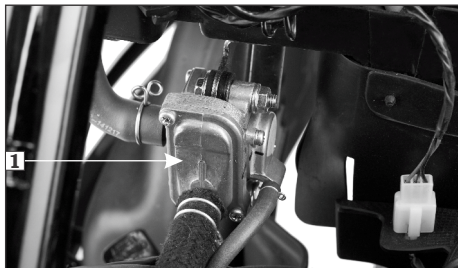

(1) Air Suction Valve

Further to meet emission standards this scooter is provided with the air suction valve.

Air Suction Valve (1) supplies fresh air from the air filter to the exhaust manifold to convert carbon monoxide to carbon dioxide. This reduces the CO% in the vehicle's exhaust.

BASIC TROUBLESHOOTING

1. STARTING TROUBLE - ENGINE DOES NOT START

A. Fuel System

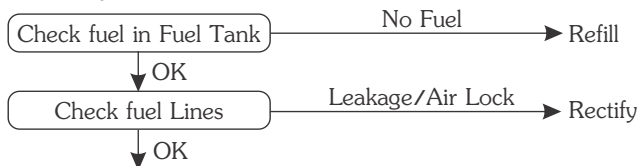

Consult Authorised Hero MotoCorp Workshop

B. Electric Starter Not Working

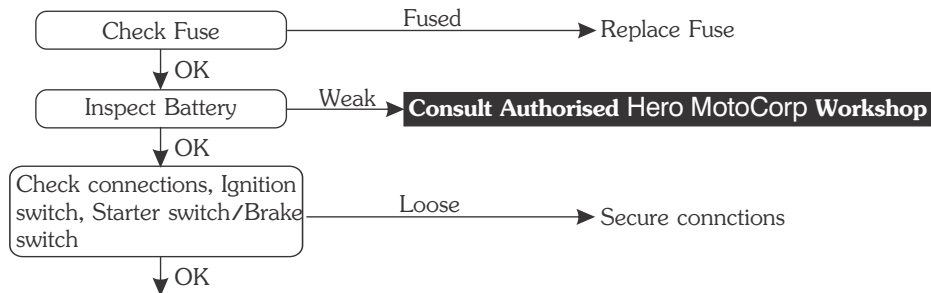

Consult Authorised Hero MotoCorp Workshop

C. No Spark At Spark Plug

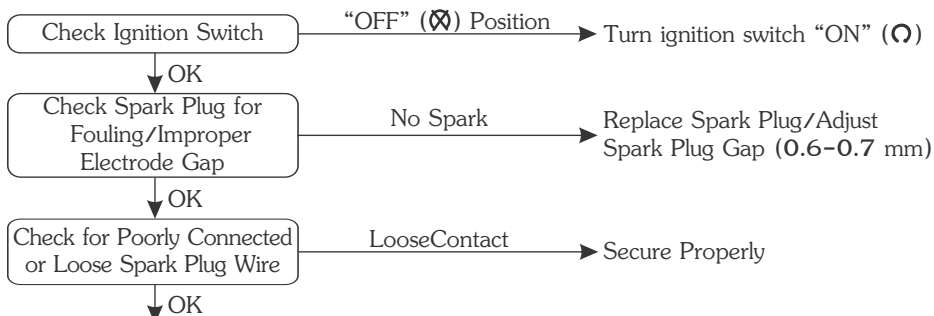

Consult Authorised Hero MotoCorp Workshop

2. ENGINE STARTS BUT STALLS

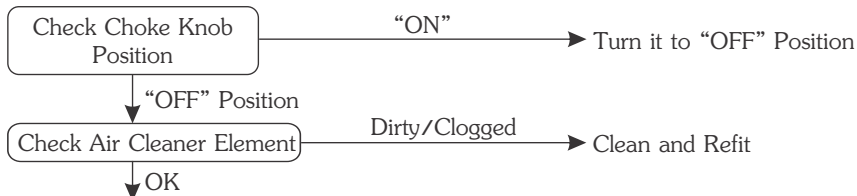

Consult Authorised Hero MotoCorp Workshop

3. POOR PICK-UP

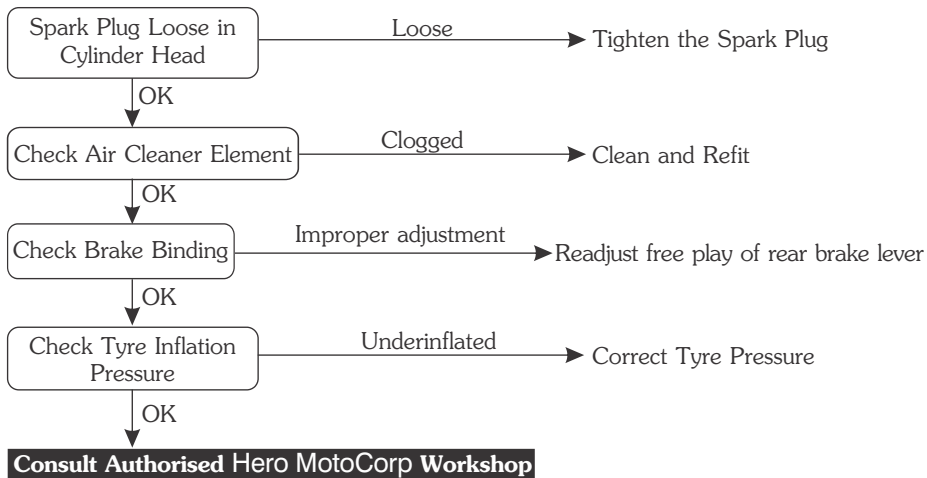

4. ELECTRICAL SYSTEM

Feeble Horn Sound or No Light

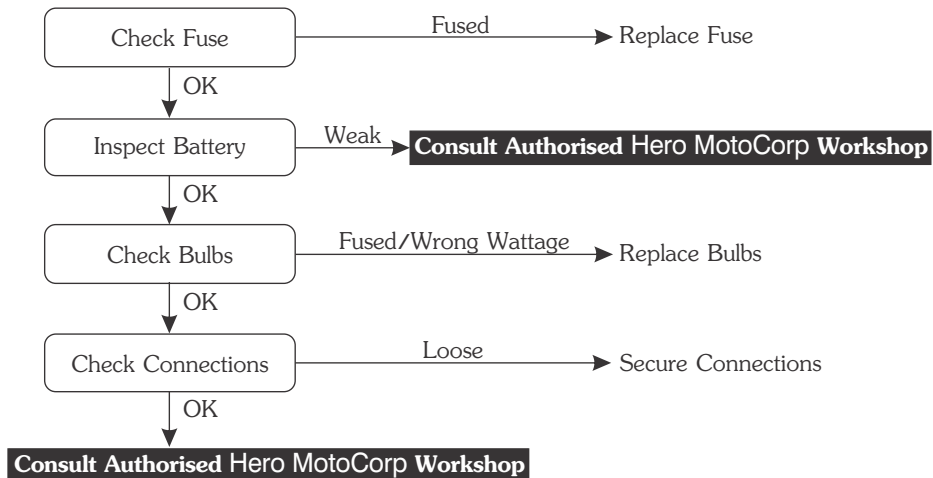

ROAD SIGNS



Mandatory signs: These road signs inform drivers/riders of the traffic rules that apply on a certain stretch of road, thereby instructing them on how to drive/ride. Mandatory signs are distinguished by the bright red circle with black and blue markings. It is imperative that all riders follow these signs as they help avoid accidents. Their violation can be penalised under the Motor Vehicle Act.

Mandatory



Stop



Give way



One way



No horn



No bicycles



No automobiles



No hand craft



No pedestrians



No right turn



No 'U' turn



Overtaking prohibited



Speed limit



No stopping or standing



No parking



Length limit



High limit



Restriction ends



Compulsory-ahead only



Compulsory-turn left



Compulsory-right ahead



Compulsory-ahead or turn right



Compulsory-keep left



Compulsory-bicycle track



Compulsory-sound horn



Cautionary

Cautionary signs: These signs inform the driver/rider of the road conditions ahead. Cautionary signs therefore serve as a warning. They are usually in a red triangle with black pictures on a white background. Illustrations, diagrams and symbols are used to forewarn about dangers ahead. Cautionary road signs are as important as mandatory signs. However, the violation of cautionary signs does not attract penalty.



Right hand curve



Right reverse bend



Incline ahead



Narrow road ahead



Narrow bridge



Pedestrian crossing



School ahead



Gap in medium



Cross road



Men at work



Roundabout



Hump Road



Informatory

Informatory signs: These are facility signs that provide important information about road directions are maps of specific destinations. On highways, they provide information about the location of public telephones, restaurants, hospitals, parking, petrol pumps, resting-places and more. These signs are usually rectangular, with black or white pictures on a blue background.



Re-assure sign



Public Telephone



Petrol Pump



Hospital



First Aid Post



Eating Place



Light Refreshment

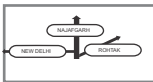

Destination Sign



Place identification sign



Resting place



No through road



No through side road



Park this side



Parking both sides



Taxistand

Signs and Signals are language of the road. Learn them, respect them .



Hero MotoCorp Ltd.

WARRANTY

Scope of warranty

Hero MotoCorp Ltd. (hereinafter called 'Hero MotoCorp') warrants its **DUET** vehicles, assembled/manufactured in its Plants and sold through its channel partners, to be free from any defect—both in material and workmanship, under normal use and conditions, subject to the following terms & conditions.

TERMS & CONDITIONS

- a) **DUET** vehicle is warranted for a period of **5 years or 50000 Km**, whichever is earlier, from the date of purchase.
- b) It is advised that the purchaser avails all free and paid services from the Hero MotoCorp's authorized workshop as per the recommended schedule, to be eligible for warranty benefits. Each paid service should be availed within **90** days from the date of previous service or as per the recommended schedule, whichever is earlier.
- c) If any problem is observed in **DUET** vehicle, Hero MotoCorp's only obligation/liability is to repair or replace that part/those parts which is/are considered to be the cause of such problem, provided however that such problem, has not resulted due to misuse/improper handling etc. of the vehicle. Any **DUET** vehicle needing repair should be brought along with Owner's Manual to Hero MotoCorp's authorised workshop for necessary inspection and carrying rectification job.



Hero MotoCorp Ltd.

LIMITATIONS OF WARRANTY

The warranty shall not apply—

- (1) If all free services/paid services/oil top-ups are not availed as per the recommended schedule at Hero MotoCorp's authorized workshop.
- (2) If any other engine oil which is non compatible with product is used other than SAE 10W30 SL Grade (JASO MB).
- (3) To normal wear & tear components including (but not limited to) brake shoes/pads, clutch plates, drive chain & sprockets, bulbs, electrical wiring, filter, spark plug, fasteners, shims, washers, oil seals, gaskets, rubber parts, bush, rubber bellows, plastic parts breakage and wheel rim for misalignment/bend.
- (4) If additional wheel(s) is/are fitted and/or any other modification carried out/unauthorized accessories fitted which shall be responsible for malfunction/deterioration of the vehicle.
- (5) If **DUET** vehicle has been used in any competitive events like races or rallies or for any commercial purposes as taxi etc.
- (6) To any damage on vehicle's painted surface cropping due to industrial pollution or other external factors.
- (7) For normal phenomena like noise vibration, oil seepage etc., which do not affect the performance of the vehicle.
- (8) To any damage caused due to usage of improper oil/grease, non-genuine parts.
- (9) If any defect crops or repairs needed as a result of using adulterated fuel.
- (10) If any maintenance/repairs required due to bad road conditions or misuse of **DUET** vehicle.
- (11) If any defect crops or repairs needed as a result of **DUET** vehicle meeting to some accident.
- (12) For consumables like oil, grease, gasket etc to be used during free services and/or warranty repairs.
- (13) To any part of the **DUET** vehicle which has been tampered or repaired in such a manner which has resulted in malfunction of the vehicle.
- (14) For **DUET** vehicle not used in accordance with the guidelines given in this Owner's Manual.
- (15) To proprietary items like Tyres, Tubes, Batteries etc, as they are subjected to the warranty terms & conditions of respective manufacturers and directly handled by them only.
- (16) Any defect(s) developing on account of external factors such as environmental factors; including but not limited to fading/peeling/rusting of paint and/or stripes and/or plated parts, seat leather tearing & cracking, aluminium parts oxidation and cracking & discoloring of control switches etc.

Decision regarding warranty settlement shall be taken by Hero MotoCorp and the same shall be final and binding on all concern.

Subject to DELHI JURISDICTION only.



Hero MotoCorp Ltd.

BATTERY WARRANTY PERIOD

1. 18 months from date of sale of vehicle or 20000 km. or
2. 21 months from the date of charging (whichever is earlier).
3. 3 months idle period is allowed from the date of charging to date of sale on vehicle.

Terms and condition of warranty

1. Batteries are warranted against all defects in material and workmanship. Liability under this warranty is limited to making good of defects rising solely from the use of faulty material or workmanship during manufacturing and developing under proper use. The warranty commences from the date of delivery to the original purchase of the vehicle.
2. In the event of any complaint the battery is to be returned complete with electrolyte to nearest battery service station or any OEM dealer. On inspection, battery would be returned or replaced.
3. This warranty card accompanies a battery sold as OEM fitment only. Claims should be supported with vehicle purchase invoice to enable processing.
4. The right to determine whether a battery needs repair or totally replacement lies with the company. In case where the battery is replaced, the defective battery becomes the property of the company and no scrap rebate will be given for it. The warranty period on the battery being repaired/replaced shall commence from the date of sale of the original battery as stated in the original warranty card.
5. All liabilities under this warranty will cease if the battery is used on the vehicle other than that on which the battery was originally fitted and on the expiry of the warranty period as mentioned above.
6. Recharging is not covered under the purview of this warranty and shall be billed as extra. However, FOC battery replacement/repair includes cost of charging.
7. This warranty does not cover damage to the battery caused by faulty electrical systems, incorrect charging and filling, improper handling of the battery by unauthorized dealers/auto electricians, maintenance, willfull abuse, destruction by fire, collusion, theft or recharging.
8. Breackage of container and cover do not come under the purview of this warranty.
9. Adjudication and settlement of claim will take a couple of days as a battery has to be tested for the reported failure.
10. In case of tempering of the original wiring circuit in any manner whatsoever.
11. If a battery which is not recommended is fitted on the vehicle then such battery will not carry any warranty.
12. The applicable taxes which is leviable on the battery under repair or replacement will be borne by the customer.
13. Customers are deemed to have read, understood and agreed to these conditions at the time of purchase of the vehicle.



Hero MotoCorp Ltd.

EMISSION WARRANTY

Scope of warranty

Hero MotoCorp Ltd. warrants all its vehicles, assembled/manufactured at its various Plants and sold through its Authorised dealers, to comply with emission standards as specified in S.No. 5 of table in item(i) of sub rule (2) of Rule 115 of Central Motor Vehicles Rules, 1989, which stipulates that "Idle CO (Carbon monoxide) emission limit for all two wheeled petrol driven vehicles shall not exceed 3.0 percent by volume and HC (Hydro Carbon) 3000 ppm, subject to following terms & conditions.

Terms & conditions

- a) The emission warranty shall be applicable in India and shall remain valid for a period of 3 years or 30000 kms, whichever occurs earlier, from the date of vehicle purchase.
- b) In case any defect is observed in any emission-related component, Hero MotoCorp only obligation/liability shall be to repair and/or replace those part (s) which is/are considered to be the cause of non-compliance with the emission standards.
- c) The emission warranty shall be applicable only to those vehicles, which are being regularly maintained at Hero MotoCorp Authorised Dealers/Service Points in accordance with the maintenance schedule provided in the owner's manual.
- d) The customer should follow the recommended parts replacement as per the maintenance schedule in order to avail the emission warranty.
- e) If any part (s) related to emission characteristics of the vehicles is/are tampered and/or repaired by unauthorised person/workshops etc, then the emission warranty shall stand cancelled.
- f) Any part (s) suffering wear and tear under the normal course of running shall not be covered under the emission warranty. Therefore, all such parts should be replaced by the customer from time to time, on payment basis, as per the maintenance schedule provided in owner's manual and dealer's advice.
- g) It is recommended to avail the services as per the recommended schedule to be eligible for the emission warranty benefits. Please ensure that each paid service is availed within 90 days from the date of previous services or as per the recommended schedule, whichever is earlier. All service details should be completely filled by the dealer, in the **Service Record Sheet** given in the owner's manual.
- h) It is mandatory to obtain a PUC certificate from the Authorised PUC center. In case of non-compliance with the emission standards please contact the channel partner/authorised workshop immediately alongwith the previous OK certificate, for the necessary rectification. The manufacturer or the dealer is not responsible for any penalty levied on you on account of non-compliance with the emission standards.
- i) All decisions regarding emission warranty settlement shall be taken by Hero MotoCorp Ltd. and shall be final binding on all concerned.

Subjected to Delhi jurisdiction only.



Hero

GENUINE PARTS

WHAT ARE THE BENEFITS OF Hero MotoCorp GENUINE SPARE PARTS ?

- Assures long life
- Ensures economy for a long time
- Safety of vehicle and rider
- Peace of mind
- Value for money
- Assured quality

CONSEQUENTIAL DAMAGES ON USING NON-GENUINE PARTS

Cam Chain Kit	<ul style="list-style-type: none">‣ Poor performance‣ Reduced life‣ Material used is inferior‣ Damages other parts of clutch like, clutch center and outer clutch
Gasket Cylinder Head	<ul style="list-style-type: none">‣ Improper sealing‣ Engine knocking‣ Leads to leakage and smoky exhaust‣ Higher emission level
Element Air Cleaner	<ul style="list-style-type: none">‣ Improper air filtration resulting in premature engine failure‣ Affects fuel efficiency‣ Poor engine performance
Spark Plug	<ul style="list-style-type: none">‣ Frequent stalling of engine‣ Higher emission level‣ Poor engine performance‣ Affects fuel efficiency

ZONAL/REGIONAL/AREA OFFICES

For any of your service related query/requirements you may contact the respective Zonal/Regional/Area Offices

CENTRAL ZONE

Hero MotoCorp Ltd., No. 209-210, Ganpati Plaza, M.I. Road, Jaipur-302001, (Rajasthan).
Tel: +91 141 2389031, +91 141 2389156, E-mail: jaipur@heromotocorp.com

Hero MotoCorp Ltd., Office No. 705-706, 7th Floor, Fun Square, Durga Nursery Road, Udaipur -313001 (Rajasthan).
Tel: +91 0294-2980578, 79, E-mail: udaipur@heromotocorp.com

Hero MotoCorp Ltd., Office, No.401, 4th Floor, Offizo, Magneto Mall, Labhandi, G.E. Road, Raipur -492 001, (Chhattisgarh)
Tel: +91-771-4034749, E-mail: raipur@heromotocorp.com

Hero MotoCorp Ltd., Third Floor, Alankar Palace, Plot No. 11, Zone II, M.P. Nagar Bhopal-462011, India.
Tel: +91-755-4203160, 2553697, 4272429, 2550086, E-mail: bhopal@heromotocorp.com

Hero MotoCorp Ltd., Maloo-01, 601-602, 6th Floor, Plot No. 26C, Scheme No. 94, Ring Road, Indore, M.P.-452010,
Tel: +91-731-4978269, 70, E-mail: indore@heromotocorp.com

EAST ZONE

Hero MotoCorp Ltd., Flat No: 1002, 10th Floor, Martin Burn Business Park, BP3, Salt Lake, Sector-V, Kolkata-700091, West Bengal, India. Tel: +91-33-44026841, +91-33-44026830, E-mail: kolkata@heromotocorp.com

Hero MotoCorp Ltd., Odysa Business Centre, Plot no. 30, 30/982, 172/1030, 4th Floor Cuttack, Bhubaneswar highway road, Rasulgarh, Bhubaneswar-751010, Odisha, India. Tel: +91-674-2581161, 62, 63, 64, E-mail: bhubaneswar@heromotocorp.com

Hero MotoCorp Ltd., Yash Heights, 1st Floor Bariatu Road, Above Basudeb Tata Showroom Ranchi-834009, Jharkhand, India. Tel: +91-651-2542222, 2542224, 2542225, E-mail: ranchi@heromotocorp.com

Hero MotoCorp Ltd., Sai Corporate Park, A Block, 6th Floor, Rukanpura, Bailey Road Patna, Bihar - 800014
Tel: +919334280555/7004569648 E-mail: patna@heromotocorp.com

NORTH ZONE

Hero MotoCorp Ltd., 3rd Floor, Tower-A, DLF Centre Court, Sector-42, Golf Course Road, DLF Phase 5, Gurgaon -122002, Haryana, India. Tel: 0124-4754800, E-mail: delhi@heromotocorp.com

Hero MotoCorp Ltd., 602, 6th Floor, Office Tower-1, Plot No BW58, Logix City Center, Sector-32, Noida - 201301.
Tel: 0120-4631000, E-mail: noida@heromotocorp.com

Hero MotoCorp Ltd., S.C.O-367-368, First Floor, Sector-34A, Chandigarh-160022, India.
Tel: +91-172-2623773, 2623774, 2623775, E-mail: chandigarh@heromotocorp.com

Hero MotoCorp Ltd., Kapoor Towers, Plot No- 284, 15-B, Rajpur Road, Dehradun-248001, India.
Tel: 0135-2714661, 2713662, 2714663, E-mail: dehradun@heromotocorp.com

ZONAL/REGIONAL/AREA OFFICES

NORTH ZONE

Hero MotoCorp Ltd., Summit Building (10th Floor) Plot No TCG 3/3 Vibhuti Khand, Gomti Nagar Lucknow – 226010, India. Tel: 0522-4006594, E-mail: lucknow@heromotocorp.com

Hero MotoCorp Ltd., C-19/134-B, Third Floor I.P Grand, Lallapura, Sagra, Varanasi, Uttar Pradesh – 221010, India. Tel: +91-0542- 2390949,2390241, E-mail: varanasi@heromotocorp.com

SOUTH ZONE

Hero MotoCorp Ltd., SKAV 909, 3rd Floor, 9/1, Lavelle Road, Bangalore-560001, India. Tel: +91-80- 46881000, E-mail: bangalore@heromotocorp.com

Hero MotoCorp Ltd., 3-6-289, 3rd Floor, Kareem Manzil, Hyderguda, Hyderabad-500029, India. Tel:+91-40-23223735, 23223727, 23223570, E-mail: hyderabad@heromotocorp.com

Hero MotoCorp Ltd., 9th Floor Seshachalam Centre No.636/1. Anna Salai, Nandanam, Chennai-600035, India. Tel: +91-44- 24340974, 24340977, 24340978, E-mail: chennai@heromotocorp.com

Hero MotoCorp Ltd., 6-A, DD Trade Tower, (6th Floor), Kaloor-Kadavanthra Road, Kaloor-682 017, Kochi-682017, India. Tel: +91-0484- 4039646 -7, E-mail: cochin@heromotocorp.com

Hero MotoCorp Ltd., No 1547, 2nd Floor Classic Towers, Trichy Road, Coimbatore – 641018
Tel: +91-422-2200058, 2200061, E-mail: coimbatore@heromotocorp.com

Hero MotoCorp Ltd., First Floor VA Kalburgi Mahalakshmi Mansion, Mandakini Hospital Road, New Cotton Market, Hubli-580029, India. Tel: 0836-2269717, 2361038, E-mail: hubli@heromotocorp.com

Hero MotoCorp Ltd., D.NO. 54-11-18 E, 2nd Floor, Sai Odessey Building, Opp Executive Club, Near NH-5, Vijayawada-520008, Andhra Pradesh, India. Tel: +91-866-2546859, 2546860, E-mail: vijayawada@heromotocorp.com

WEST ZONE

Hero MotoCorp Ltd., Chrome Building, Sr. No. 33, Hissa-A-1/1/2, Plot – 2, Viman Nagar Avenue 2, Nagar Road, Pune-411014, India. Tel: +91-020-71903500, E-mail: pune@heromotocorp.com

Hero MotoCorp Ltd., 603-604, Gunjan Tower, Off Alembic Gorwa Road, Baroda-390023, India. Tel: +91-265-2286569/2286570, E-mail: baroda@heromotocorp.com

Hero MotoCorp Ltd., Ground Floor, Block No.2, Vishnu Vaibhav Complex, 222, Palm Road, Civil Lines, Nagpur-440001 India. Tel: +91-712-2545990-91, E-mail: nagpur@heromotocorp.com

Hero MotoCorp Ltd., Astarc House-Third Floor, 76/79, Makwana Lane, Off. Andheri-Kurla Road, Andheri (East), Mumbai-400059, India. Tel: +91-22-28562071, E-mail: mumbai@heromotocorp.com

Hero MotoCorp Ltd., 604, Kings Plaza, Astron Chowk, Rajkot, Gujarat – 360001
Tel: 0281-2460622, 2460623, E-mail: rajkot@heromotocorp.com