

Project _____
 Item _____
 Quantity _____
 CSI Section 11400
 Approval _____
 Date _____

Models TempStar®



Standard Features

- Multi-cycle timer (Extra Heavy, Heavy, Medium, Normal)
- Specially designed stainless steel nozzles provide superior cleaning action
- Built-in 70 °F (38.9 °C) rise booster heater with Sani-Sure™ final rinse system is standard; 40 °F (22.2 °C) rise booster heater is available but must be specified at time of order
- 17-1/4" (438 mm) door opening accepts 18" (457 mm) trays
- Interchangeable wash/rinse arms screw out for simple cleanup
- Auto-fill/auto-start
- Door switch
- Delime/manual wash switch
- Vent fan control - shuts vent fan off when machine is idle
- Low watt density electric wash tank heater
- Hi-limit thermostat and low water protection
- Top mounted controls for ease of operation
- Adjustable bullet feet
- Uses standard 20" X 20" (508 mm X 508 mm) racks
- Front dress panel
- Detergent/rinse additive signal connection fuse box
- Self-draining stainless steel pump
- Large scrap basket

Mandatory Specs

Specify:
 Specify voltage _____
 Specify booster size _____

Options

- Optional 40 °F (22.2 °C) rise booster heater is available at no additional cost (must be specified on P.O.)
- 460V Electrical
- Single Phase
- Pressure Regulator
- Drain Water Tempering Kit
- Scaltrol
- Water Hammer Arrestor
- Flanged Feet
- False Panel (for corner installations)
- Door Interlock
- Steam Booster Heater
- Security Package

Accessories

- 36-Compartment Rack
 - 4-1/8" tall (105 mm)
 - 5-5/8" tall (143 mm)
 - 7" tall (178 mm)
- Combination Rack
- Peg Rack

Specifications

Uses 0.89 gallons (3 liters) of water per rack
 Total automatic (normal) cycle - 57 seconds
 58 racks per hour (normal) cycle
 1 hp wash pump motor
 Single point connections for all utilities

Field convertible from straight through to corner and vice versa

Field convertible from 3-phase to single-phase and vice versa

Durable stainless steel construction



Intertek



Intertek



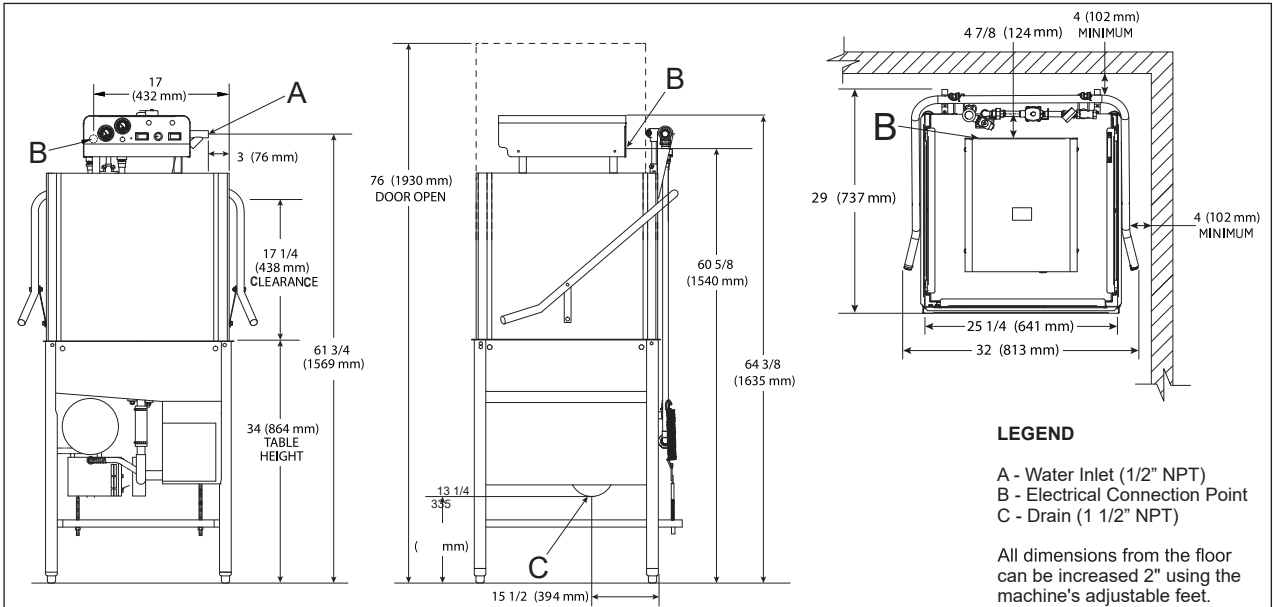

MODEL NO.	MACHINE DIMENSIONS				DRAIN HEIGHT	SHIPPING INFORMATION					
	HEIGHT	WIDTH	WIDTH BETWEEN TABLES	DEPTH		WEIGHT	CLASS	CUBE	HEIGHT	WIDTH	DEPTH
TempStar®	64-3/8" (1635 mm)	32" (813 mm)	25-1/4" (641 mm)	25-1/4" (641 mm)	13-1/4" (335 mm)	263 lbs (120 kg)	200	58.15 cu. ft.	72.5" (1842 mm)	33" (839 mm)	42" (1067 mm)

DIMENSIONS	
Wall Clearance (minimum)	4" (102 mm)
Standard Table Height	34" (864 mm)
Inside Clearance	17-1/4" (438 mm)
Machine Height with Door Open	76" (1933 mm)

OPERATING CAPACITY					
Cycle/Racks per Hour	Normal 58	Medium 30	Heavy 20	Extra Heavy 12	
OPERATING CYCLE (seconds)		Wash	Rinse	Dwell	Total Cycle
Normal	40	13	4	57	
Medium	100	13	4	117	
Heavy	160	13	4	177	
Extra Heavy	280	13	4	297	

OPERATING TEMPERATURES	
Wash (minimum)	150 °F (66 °C)
Rinse (minimum)	180 °F (82 °C)

WATER	
Inlet Temperature	
40 °F (22.2 °C) Rise	140 °F (60 °C)
70 °F (38.9 °C) Rise	110 °F (43 °C)
No Booster	180 °F (82 °C)
Gallons per Hour	52 gal (197 L)
Gallons per Rack	.89 gal (3 L)
Waterline Size IPS (minimum)	1/2"
Drainline Size IPS (minimum)	1- 1/2"
Flow Pressure (PSI)	10
Wash Tank Capacity	8 gal (30 L)
Booster Tank Capacity	3 gal (11 L)

ELECTRICAL				
	Power Supply	Total Load	Minimum Circuit Ampacity	Maximum Overcurrent Protection
With 70 °F Rise Booster	208/60/3	45.6 A	46.8 A	50 A
	230/60/3	49.8 A	51.1 A	55 A
	460/60/3	23.7 A	24.0 A	25 A
	208/60/1	75.2 A	76.5 A	80 A
With 40 °F Rise Booster	230/60/1	82.7 A	83.9 A	85 A
	208/60/3	41.4 A	42.6 A	45 A
	230/60/3	45.2 A	46.5 A	50 A
	460/60/3	21.4 A	21.7 A	25 A
	208/60/1	68.0 A	69.3 A	70 A
With No Booster	230/60/1	74.7 A	75.9 A	80 A
	208/60/3	16.4 A	17.6 A	20 A
	230/60/3	17.6 A	18.8 A	20 A
	460/60/3	7.5 A	7.8 A	15 A
	208/60/1	24.7 A	25.9 A	30 A
230/60/1	26.8 A	28.0 A	30 A	

WASH PUMP MOTOR	
208V/230V	1 HP
460V	3/4 HP

HEATERS			
Voltage	Electric Wash Tank Heater	Electric Rinse Tank Heater 40 °F (22.2 °C) Rise	Electric Rinse Tank Heater 70 °F (38.9 °C) Rise
208	4.1kW	9.0kW	10.5kW
230	5.0kW	11.0kW	12.9kW
460	5.0kW	11.0kW	12.9kW

HOW TO SPECIFY: TempStar®

Jackson WWS, Inc.
 Shipping Address: 6209 North U.S. Highway 25E, Gray, KY 40734
 Mailing Address: P.O.Box 1060, Barbourville, KY 40906
 Telephone: 888-800-5672 • Fax: 606-523-1799
 Email: info@jacksonwws.com
 07610-002-66-59 [12/04/2020]

www.jacksonwws.com