

ARISTA



Quick Start Guide

7300 Series Modular Data Center Switches

DCS-7304
DCS-7308
DCS-7316

Arista Networks

www.arista.com

PDOC-00040-03

Headquarters	Support	Sales
5453 Great America Parkway Santa Clara, CA 95054 USA		
408 547-5500	408 547-5502 866 476-0000	408 547-5501 866 497-0000
www.arista.com	support@arista.com	sales@arista.com

© Copyright 2014 Arista Networks, Inc. The information contained herein is subject to change without notice. Arista Networks and the Arista logo are trademarks of Arista Networks, Inc in the United States and other countries. Other product or service names may be trademarks or service marks of others.

Chapter 1 Overview

1.1 Scope

This guide is intended for properly trained service personnel and technicians who need to install the following Arista Networks Data Center Switches:

- DCS-7304
- DCS-7316
- DCS-7308

Important! Only qualified personnel should install, service, or replace this equipment.

1.2 Receiving and Inspecting the Equipment

Upon receiving the switch, inspect the shipping boxes and record any external damage. Retain packing materials if you suspect that part of the shipment is damaged; the carrier may need to inspect them.

If the boxes were not damaged in transit, unpack them carefully. Ensure that you do not discard any accessories that may be packaged in the same box as the main unit.

Inspect the packing list and confirm that you received all listed items. Compare the packing list with your purchase order. Appendix C provides a list of components included with the switch.

1.3 Installation Process

The following tasks are required to install and use the switch:

- Step 1** Select and prepare the installation site (Section 2.1).
- Step 2** Assemble the installation tools listed in Section 2.2.
- Step 3** Attach the mounting brackets and install the switch in an equipment rack (Chapter 3).
- Step 4** Connect the switch to the power source and network devices (Chapter 4).
- Step 5** Configure the switch (Chapter 5).

Important! Class 1 Laser Product: This product has provisions to install Class 1 laser transceivers that provides optical coupling to the communication network. Once a Class 1 laser product is installed, the equipment is a Class 1 Laser Product (Appareil à Laser de Classe 1). The customer is responsible for selecting and installing the Class 1 laser transceiver and for insuring that the Class 1 AEL (Allowable Emission Limit) per EN/IEC 6-825, CSA E60825-1, and Code of Federal Regulations 21 CFR 1040 is not exceeded after the laser transceiver have been installed. Do not install laser products whose class rating is greater than 1. Refer to all safety instructions that accompanied the transceiver prior to installation. Only Class 1 laser devices certified for use in the country of installation by the cognizant agency are to be utilized in this product.

Important! Ultimate disposal of this product must be handled in accordance with all national laws and regulations.

The fabric module requires special handling when removing, inserting, or handling the component. Appendix B provide instructions for handing fabric modules.

1.4 Safety Information

Refer to the Arista Networks document Safety Information and Translated Safety Warnings available at:

<http://www.arista.com/en/support/docs/eos>

1.5 Obtaining Technical Assistance

Any customer, partner, reseller or distributor holding a valid Arista Service Contract can obtain technical support in any of the following ways:

- **Email:** support@arista.com. This is the easiest way to create a new service request.
Include a detailed description of the problem and the output of “show tech-support”.

- **Web:** www.arista.com/en/support.

A support case may be created through the support portal on our website. You may also download the most current software and documentation, as well as view FAQs, Knowledge Base articles, Security Advisories, and Field Notices.

- **Phone:** 866-476-0000 or 408-547-5502.

Important! No user serviceable parts inside. Refer all servicing to qualified service personnel.

1.6 Specifications

Table 1 lists specifications of Arista Data Center modular switches and components covered by this guide.

Table 1: 7300 Modular Switch and Component Specifications

Size (W x D x H)	DCS-7304 DCS-7308 DCS-7316	8 RU: 44.1 x 60.3 x 35.2 cm (17.4 x 23.7 x 13.9 inches) 13 RU: 44.1 x 60.3 x 57.2 cm (17.4 x 23.7 x 22.5 inches) 21 RU: 44.1 x 70.6 x 93.0 cm (17.4 x 27.8 x 36.6 inches)
Weight (Empty / Fully Loaded)	DCS-7304 DCS-7308 DCS-7316	36 kg (78 pounds) / 86 kg (189 pounds) 50 kg (110 pounds) / 136 kg (299 pounds) 81 kg (178 pounds) / 244 kg (536 pounds)
Operating Temperature Storage Temperature Operating Altitude Relative Humidity	all switches all switches all switches all switches	0° to 40° C (32° to 104° F) -40° to 70° C (-40° to 158° F) 0 to 3,000 meters (0 to 10,000 feet) 5 to 90%
Power Input Circuits	DCS-7304 DCS-7308 DCS-7316	1 to 4 circuits 2 to 6 circuits 3 to 8 circuits
Input Power (per circuit)	DCS-7304 DCS-7308 DCS-7316	200 - 240 VAC, 16 A (20 A US), 50 or 60 Hz 200 - 240 VAC, 16 A (20 A US), 50 or 60 Hz 200 - 240 VAC, 16 A (20 A US), 50 or 60 Hz
Cooling	DCS-7304 DCS-7308 DCS-7316	3000 W 6000 W 12000 W
Power Draw (Typical / Maximum)	DCS-7300E-SUP DCS-7300X-32Q-LC DCS-7300X-64S-LC DCS-7300X-64T-LC DCS-7304X-FM DCS-7308X-FM DCS-7316X-FM	65 W / 80 W 219 W / 372 W 166 W / 232 W 279 W / 430 W 98 W / 172 W 195 W / 343 W 550 W / 760 W

Chapter 2 Preparation

2.1 Site Selection

The following criteria should be considered when selecting a site to install the switch:

- **Floor Space:** Install the switch in an area that provides adequate clearance for removing front and rear components. Figure 1 displays switch clearance requirements.

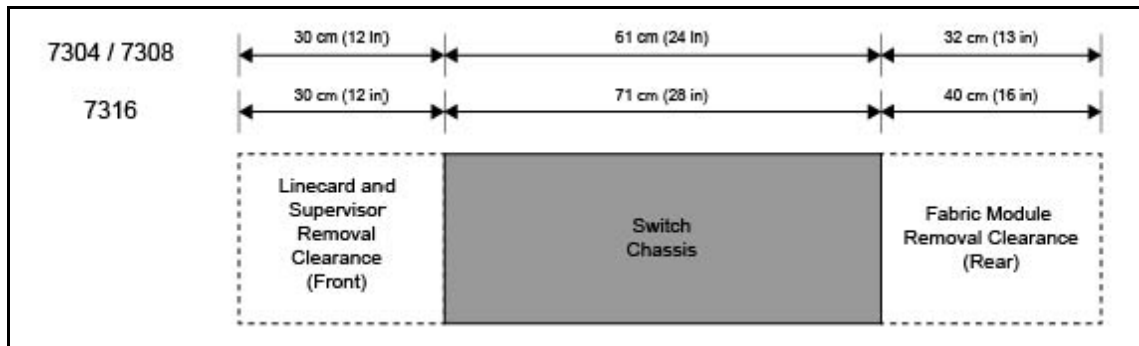

Figure 1: Switch Component Removal Footprint

- **Temperature and Ventilation:** For proper ventilation, install the switch where there is ample airflow to the front and back of the switch. The temperature should not go below 0° or exceed 40° C.

Important! To prevent the switch from overheating, do not operate it in an area where the ambient temperature exceeds limits specified in Table 1.

- **Airflow Orientation:** Determine airflow direction of the fan modules and power supply modules. Fan and power supply module handles indicate airflow direction:

- **Blue Handle:** Air Inlet module.
- **Red Handle:** Air Exit module.

Appendix D displays power supply module locations on the front panel. Appendix E displays fan module locations on the rear panel (DCS-7316 switches may also contain rear panel power supply modules). Verify the airflow direction of all modules satisfy these criteria:

- All rear panel modules have the same color handles.
- All front panel modules have the same color handles.
- Rear panel modules must have different color handles than front panel modules.

Orient the switch to assure that the air intake modules face the cool aisle. If the airflow direction is not compatible with the installation site, contact your sales representative to obtain modules that circulate air in the opposite direction.

- **Rack Space:** Install the switch in a 19" rack or cabinet. The switch height depends on the switch model, as specified in Table 1. Verify that the linecard and supervisor removal clearance (Figure 1) provide adequate space for the power and data cables that connect to the switch.

When mounting the switch in a partially filled rack, load the rack from bottom to top, with the heaviest equipment at the bottom. Load the switch at the bottom if it is the only item in the rack.

The accessory kit provides mounting brackets for four-post racks. Contact your sales representative to obtain two-post mounting racks.

- **Power Requirements:** Power requirements vary by switch. Refer to Table 1 for information regarding your specific system.

Multiple circuits provide redundancy protection. The switch uses power cables that have an IEC-320 C19 plug. The accessory kit provides IEC-320 C19 to C20 power cables.

Important! All power input plug-socket combinations must be accessible at all times; they provide the primary method of disconnecting power from the system.

- **Other Requirements:** Select a site where liquids or objects cannot fall onto the equipment and foreign objects are not drawn into the ventilation holes. Verify these guidelines are met:
 - Clearance areas to the front and rear panels allow for unrestricted cabling.
 - All front and rear panel indicators can be easily read.
 - AC power cords can reach from the AC power outlet to the connectors on the front panel.

Important! Disconnecting power to all input sockets is required to completely power off the unit.

2.2 Tools Required for Installation

Each switch provides an accessory kit that contains parts for installing the switch into a four-post rack. Two-post rack mount parts are available through your sales representative. Accessory kits do not include screws, nuts, or bolts for attaching the switch to a conventional rack.

In addition to the accessory kit, the following tools are required to install a modular switch:

All Racks

- Mechanical device capable of lifting chassis being installed (Chassis weight listed in Table 1).

Two-Post Conventional Rack

- Screws or rack mounting nuts and bolts.
- Screwdriver.

Four-Post Tool-less Rack

No additional equipment required.

Four-Post Conventional Rack

- Screws or rack mounting nuts and bolts.
- Screwdriver.

2.3 Electrostatic Discharge (ESD) Precautions

Observe these guidelines to avoid ESD damage when installing or servicing the switch.

- Assemble or disassemble equipment only in a static-free work area.
- Use a conductive work surfaces (such as an antistatic mat) to dissipate static charge.
- Wear an ESD wrist strap to dissipate static charge accumulation.
- Minimize handling of assemblies and components.
- Keep replacement parts in their original static-free packaging.
- Remove all plastic, foam, vinyl, paper, and other static-generating materials from the work area.
- Use tools that do not create ESD.

Chapter 3 Rack Mounting the Switch

Important! The rack mounting procedure is identical for all modular switches. Illustrations in this chapter depict the mounting of an unpopulated DCS-7304 chassis.

- Section 3.1 provides instructions for mounting the switch in a two-post rack.
- Section 3.2 provides instructions for mounting the switch in a four-post rack.

After completing the instructions for your rack type, proceed to Chapter 4.

3.1 Two-Post Rack Mount

To mount the switch to a two-post rack, assemble mounting brackets to the middle of the chassis, then attach the brackets to the rack.

Important! Two-post rack mount parts are only available through your sales representative. Two-post rack mounting is not supported for DCS-7316 switches.

The accessory kit includes the following two-post mounting parts:

- 2 center-mount brackets
- 16 (DCS-7304) or 20 (DCS-7308) M4x8 panhead Phillips screws

Figure 27 displays the two-post mounting parts.

3.1.1 Attaching Mounting Brackets to the Chassis

Step 1 Orient the switch chassis and the two center-mount brackets (Figure 2).

Position the flanges that attach to the rack posts toward the front of the chassis.

Step 2 Attach both center-mount brackets to the chassis with the provided M4x8 panhead Phillips screws. Secure the bracket by attaching screws through each bracket hole.

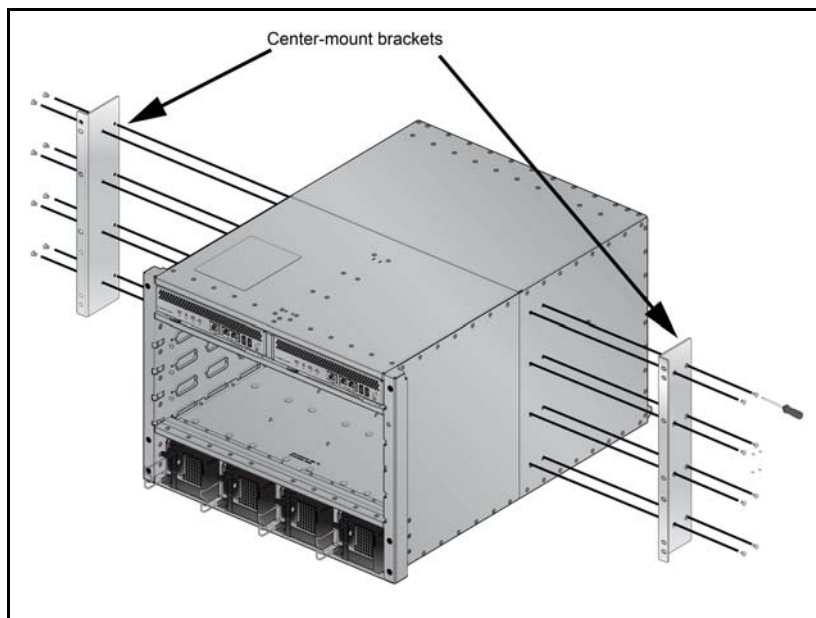

Figure 2: Attaching the Center-mount Brackets

3.1.2 Inserting the Switch into the Rack

Step 1 Move the chassis to the rack using a mechanical lift (Figure 3-left).

If modules are inserted in the chassis, use the lift carefully to avoid damaging any components.

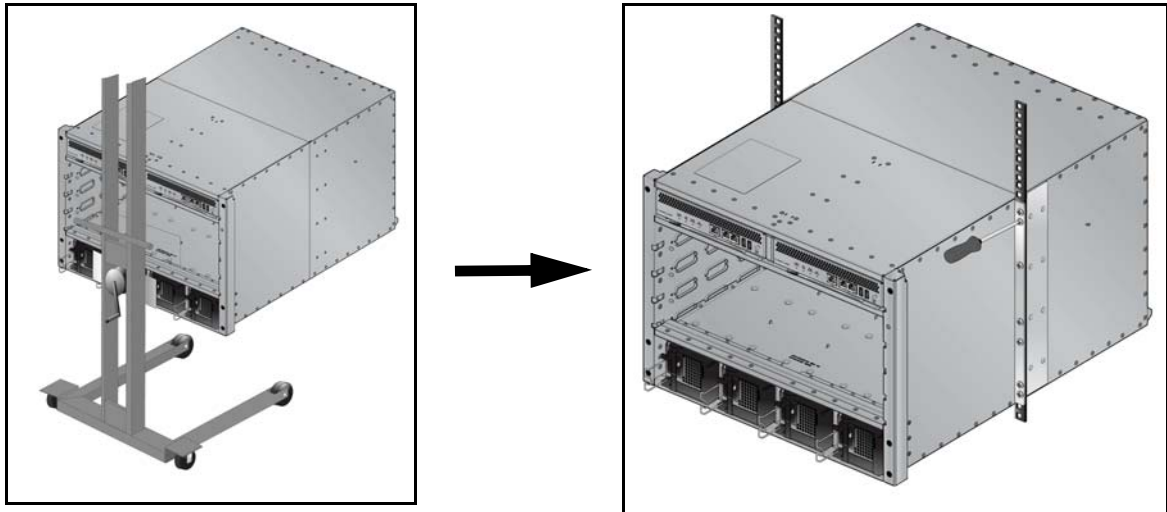

Figure 3: Lifting the Switch Chassis into the Two Post Rack

Step 2 Lift the chassis into the rack. Position the flanges against the rack posts (Figure 3-right).

Step 3 Select mounting screws that fit your equipment rack.

Step 4 Attach the bracket flanges to the rack posts. Secure the switch to the rack with screws through each bracket hole.

After completing the two-post installation, proceed to Chapter 4.

3.2 Four-Post Rack Mount

The switch is mounted onto a four-post rack by assembling a shelf into the rack, then attaching the switch on the shelf. The four-post rack mount instructions include these sections:

- Section 3.2.1: Component Description
- Section 3.2.2: Component Placement
- Section 3.2.3: Switch Mounting Process

3.2.1 Component Description

The four-post mount accessory kit contains these components:

- 1 Left Shelf and 1 Right Shelf (Section 3.2.1.1)
- 2 Mounting Ears (Section 3.2.1.2)

Important! Components are designed for tool-less installation in square-hole racks. To install the switch in round hole or threaded hole racks, remove all rack plugs (described below) and attach all components with nuts and bolts that fit the rack.

3.2.1.1 Shelves

The two shelves are almost identical, differing in that 1) they are mirror-images of each other, and 2) the left shelf includes a stabilizer bar. Each shelf is a two-piece mechanism. The **base** includes the surface upon which the switch is placed and is oriented towards the front of the rack. The **slide-end** adjusts the shelf's length for fitting the shelf between front and rear posts of various size racks.

Figure 4 displays the inner view of the left shelf. Each shelf includes latches to the locking mechanism that secures the shelf to the rack. Figure 4 displays latches that are closed; the insets display open latches. The inner side of each shelf is oriented toward the center of the rack.

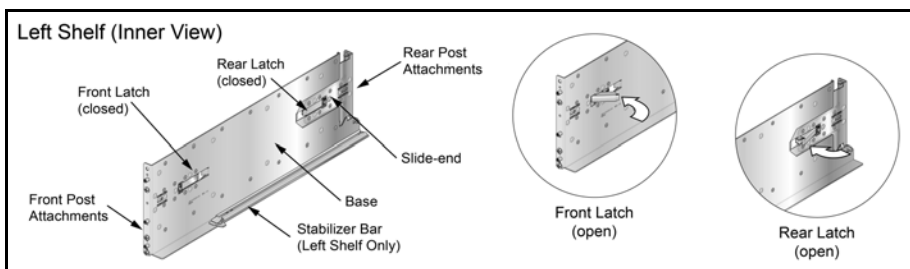

Figure 4: Left Shelf – Inner View

Figure 5 displays the outside view of the right shelf, from where rack plugs and guide pins that insert into rack posts are visible (Insets A and B). To install shelves into posts with threaded or rounded holes, remove all plugs from the shelves, then attach the shelves with bolts that fit the rack.

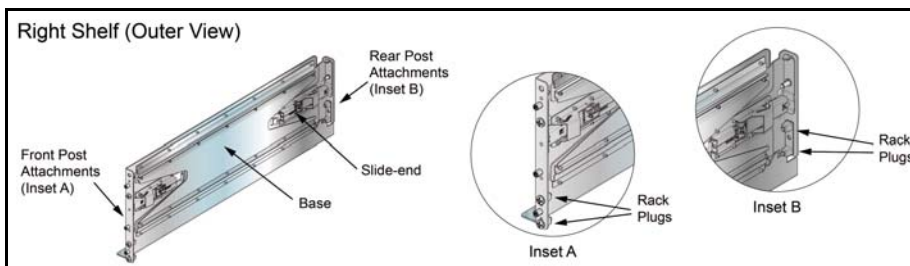

Figure 5: Right Shelf – Outer View

3.2.1.2 Mounting Ears

Figure 6 displays the mounting ears, which secure the switch top to the rack. The two mounting ears are identical and installed above each shelf. The inner side of each ear includes a latch to the locking mechanism that secures the ear to the rack.

Rack posts and guide pins that insert into the rack are visible from the outer side of the ear (Inset B). To install ears into posts with threaded or rounded holes, remove both plugs from each ear, then install the ears with screws that fit the rack.

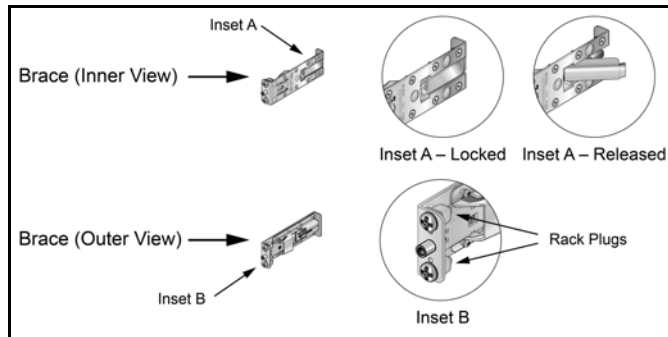

Figure 6: Mounting Ears

3.2.2 Component Placement

Figure 7 displays component placement for a 7304 (8-RU) switch. Mounting ears brace the top of the switch; their rack placement position differs for each switch model. Using the placement of the shelves' bottom front rack plug as a reference (first RU and first hole), the mounting ears are placed as follows:

- 7304: 8th RU (22nd through 24th holes)
- 7308: 13th RU (37th through 39th holes)
- 7316: 21st RU (61st through 63rd holes)

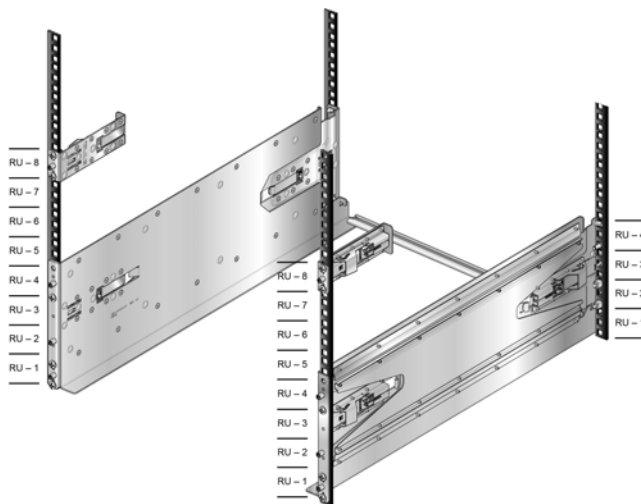

Figure 7: Component Placement

3.2.3 Switch Mounting Process

The switch mounting process consists of three steps: 1) installing the shelves; 2) installing the mounting ears; and 3) placing and securing the switch upon the shelves.

3.2.3.1 Shelf Installation

The installation process for each shelf is identical. The shelves must be installed on the same horizontal level. In the following section, inner side illustrations feature the left shelf and outer side illustrations feature the right shelf.

Perform the following procedure for each shelf:

- Step 1** Verify that both locking mechanism latches on the shelf are open (Figure 5, insets A and B).
- Step 2** Attach the front side of the shelf to its corresponding front rack post by inserting the shelf-side rack plugs and guide pins into post slots (Figure 8).

The shelf ledge must be between the front posts. If the rack plugs were previously removed, use bolts to attach the shelf to the rack.

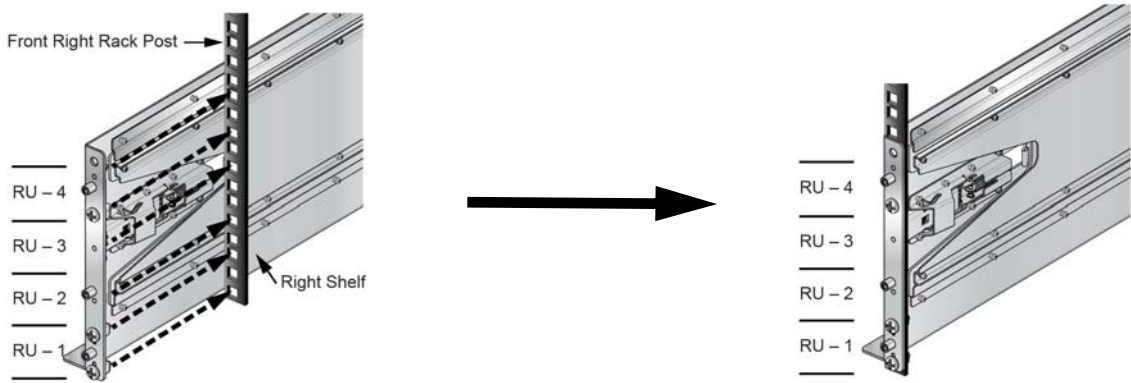

Figure 8: Attaching the Right Shelf

- Step 3** Close the front locking mechanism latch (Figure 5).
- Step 4** Glide the slide-end to a position outside of its rear rack post (Figure 9).

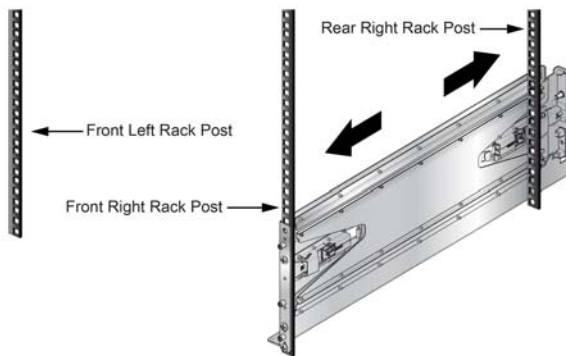

Figure 9: Adjusting the Right Shelf

Step 5 Attach the back-side of the shelf into the rear shelf by gliding the slide-end such that the rack plugs and guide pins are inserted into the rack post holes. The bottom rack plug must be inserted one RU (three rack holes) above the bottom rack plug on the front side of the shelf.

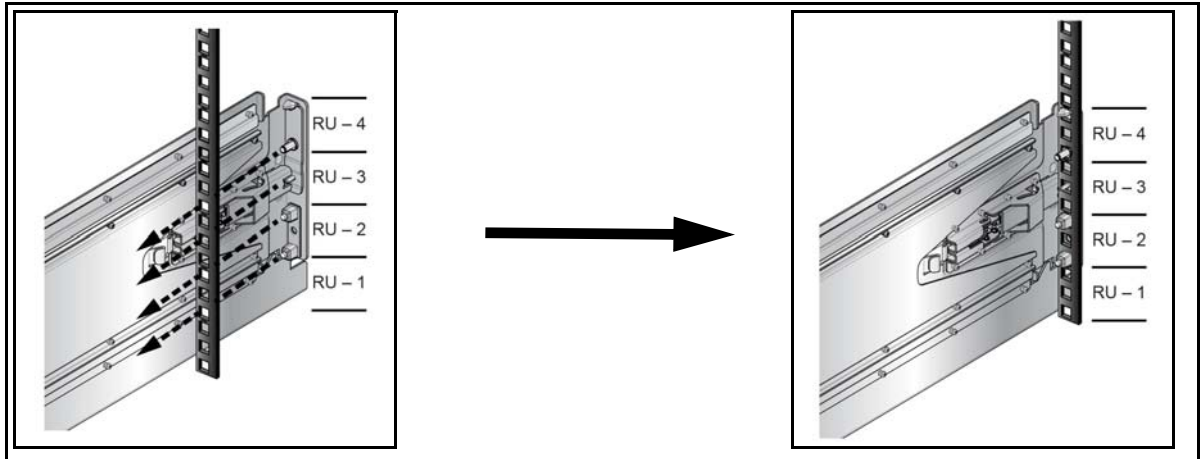

Figure 10: Seating the Left Shelf

Step 6 Close the rear locking mechanism latch (Figure 5).

3.2.3.2 Mounting Ear Installation

The mounting ears attach the top of the switch to the rack posts. Their placement on the posts depend on the switch model (Section 3.2.2).

The installation process for each mounting ear is identical. The inner side of the mounting ear (which includes the locking mechanism latch) is oriented between the front rack posts. In the following section, all illustrations feature the right mounting ear.

Perform the following procedure for each mounting ear:

Step 1 Install the mounting ear on the front post by inserting the front rack plugs and guide pins in the racks specified for the switch model that is being installed (Figure 11).

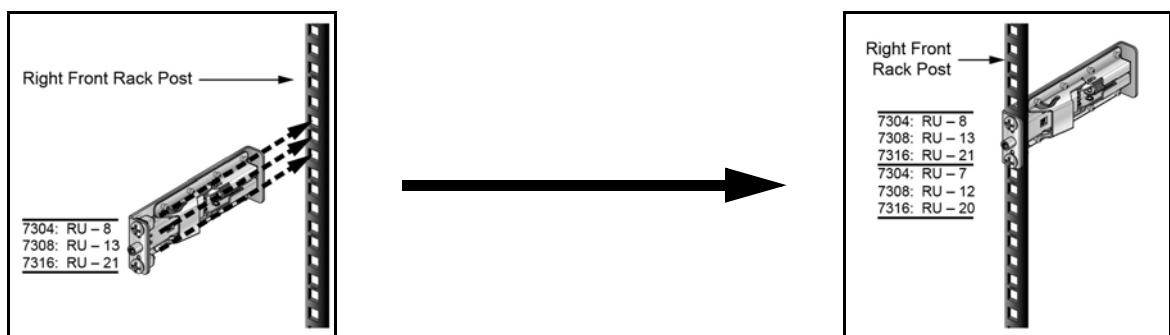

Figure 11: Attaching the Right Mounting Ear

Step 2 Close the front locking mechanism latch (Figure 6).

3.2.3.3 Inserting the Switch into the Rack

Step 1 Rotate the stabilizer bar from the left shelf toward the right shelf such that the nob at the end of the stabilizer bar inserts into the notch at the rear of the ledge of the right shelf.



Figure 12: Both Switch Shelves Installed

Step 2 Move the chassis to the rack using a mechanical lift (Figure 13-right). If modules are inserted in the chassis, use the lift carefully to avoid damaging any components.

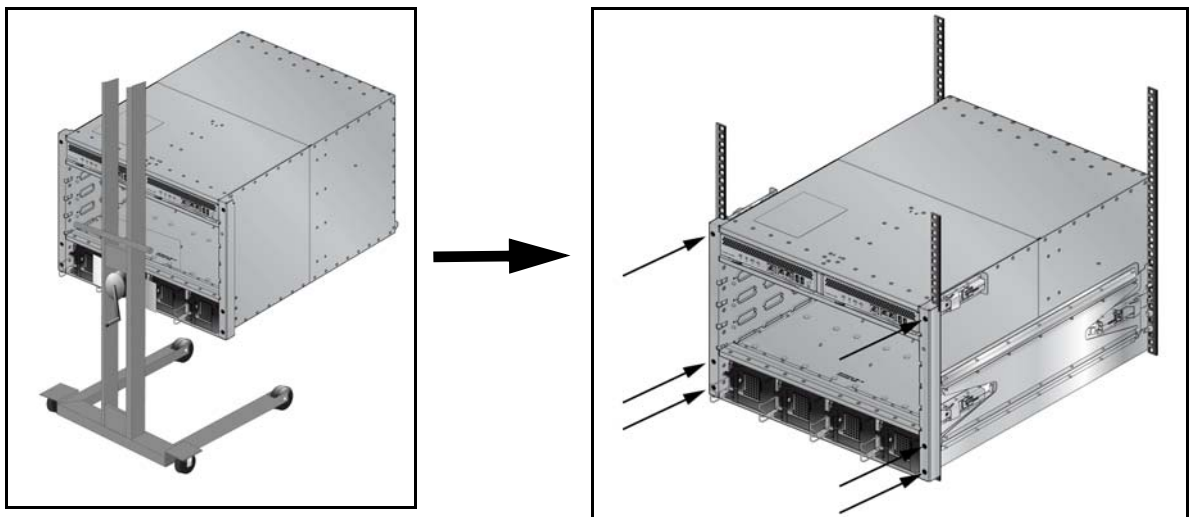

Figure 13: Lifting the Switch Chassis

Step 3 Lift the chassis into the rack.

Step 4 Secure the chassis by tightening the six thumbscrews on the front flanges into the rack posts.

After completing the Four-Post Installation, proceed to Chapter 4.

Chapter 4 Cabling the Modular Switch

4.1 Grounding the Switch

After mounting the switch into the rack, connect the switch to the data center ground. Figure 14 displays the location of the grounding pads located on the bottom corners of the front panel.

Important! Grounding wires and grounding lugs (M4 x 0.7) are not supplied. Wire size should meet local and national installation requirements. Commercially available 6 AWG wire is recommended for installations in the U.S.

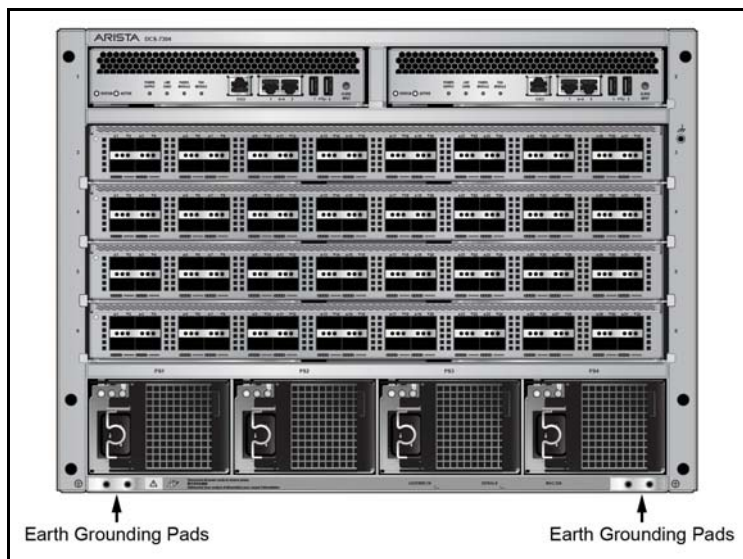

Figure 14: Grounding Pad and ESD Grounding Port Sockets

After the switch is grounded, ESD wrist straps can be grounded by connecting them to one of the ESD grounding ports located below the power supply modules, (Figure 14) or the rear panel (Figure 15 depicts the location on the 7304). Receptacles are available in similar locations on other switch models.

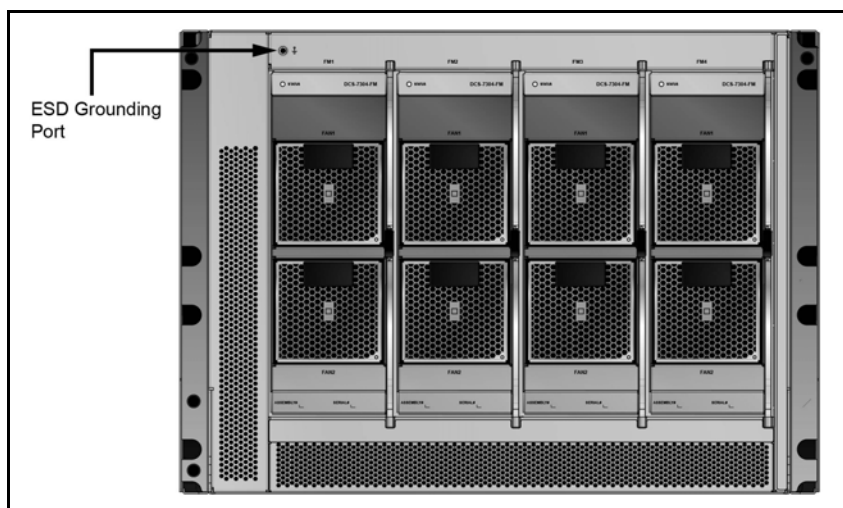

Figure 15: ESD Grounding Port – Rear Panel

4.2 Connecting Power Cables

Important! Installation of this equipment must comply with local and national electrical codes. If necessary, consult with the appropriate regulatory agencies and inspection authorities to ensure compliance.

The switch operates with multiple power supplies. Refer to Table 1 for information regarding your specific system. Table 2 lists the quantity of modules each chassis can contain and the minimum operating requirements for each model.

Table 2: Power Supply Capacity and Requirements for 7300 Series Modular Switches

Switch Model	Chassis Capacity	Minimum Operating Requirements
DCS-7304	Front Panel: 4 modules	1 active circuit
DCS-7308	Front Panel: 6 modules	2 active circuits
DCS-7316	Front Panel: 6 modules Rear Panel: 2 modules	3 active circuits

Appendix D displays the location of the power supplies on the front panel of the switch. Appendix E displays the location of power supplies on the rear panel of DCS-7316 switches.

Important! Read all installation instructions before connecting the system to the power source.

- **Non-Redundant Configuration:** Provide power to the minimum required power inputs.
- **Redundant Power Supply Configuration:** Connecting power to modules in excess of minimum requirements protects the switch against failed modules and can provide grid-level redundancy.
- **Power down the Switch:** Remove all power cords from the power input sockets.

Important! This equipment must be grounded. Never defeat the ground conductor.

Important! This unit requires overcurrent protection for the AC mains current.

Figure 16 displays an AC power supply module, including the power input socket..

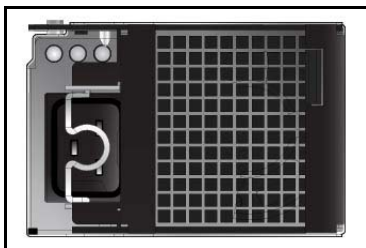

Figure 16: Power Input Sockets

The power supplies require power cables that comply with IEC-320 and have a C19 plug. The accessory kit provides 14 AWG, C19 to C20 power cables, each two meters long.

To insert a power cable:

- Step 1** Pull the retaining clip back on each power input socket.
- Step 2** Plug the power cables into the sockets.
- Step 3** Adjust the retaining clips if needed for your power cords.
- Step 4** Push the retaining clip back down over the cable.

4.3 Connecting Supervisor Cables

Supervisor modules contain console, management, and USB ports. Figure 17 displays port locations on 7300 Series Modular switch supervisors.

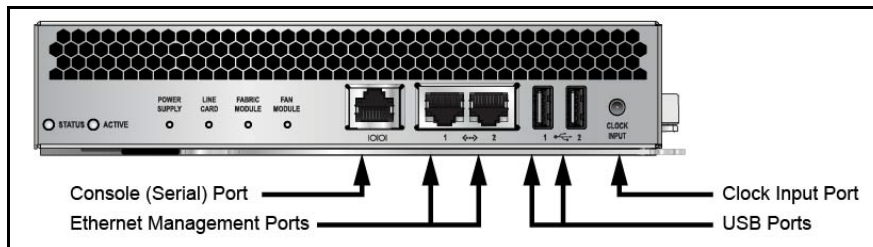

Figure 17: Supervisor Ports

- **Console (Serial) Port:** Connect to a PC with RJ-45 to DB-9 serial adapter cable. Default switch settings include:
 - 9600 baud
 - No flow control
 - 1 stop bit
 - No parity bits
 - 8 data bits
- **Ethernet management port:** Connect to 10/100/1000 management network with RJ-45 cable.
- **USB Port:** May be used for software or configuration updates.
- **Clock Input Port:** Port type is MCX connector, 2-5.5V, 50 ohm termination.

4.4 Connecting Linecard Modules and Cables

Install required SFP, SFP+, and QSFP+ optic modules in linecard module ports (Figure 18).



Figure 18: SFP or SFP+ ports

Connect cables as required to linecard module ports or RJ45 ports.

Caution Excessive bending can damage interface cables, especially optical cables.

Chapter 5 Configuring the Switch

Arista switches ship from the factory in Zero Touch Provisioning (ZTP) mode. ZTP configures the switch without user intervention by downloading a startup configuration file or a boot script from a location specified by a DHCP server. To manually configure a switch, ZTP is bypassed. The initial configuration provides one username (*admin*) accessible only through the console port because it has no password.

When bypassing ZTP, initial switch access requires logging in as *admin*, with no password, through the console port. Then you can configure an *admin* password and other password protected usernames.

This manual configuration procedure cancels ZTP mode, logs into the switch, assigns a password to *admin*, assigns an IP address to the management port, and defines a default route to a network gateway.

Step 1 Provide power to the switch (Section 4.2).

Step 2 Connect the console port to a PC (Section 4.3).

As the switch boots without a *startup-config* file, it displays this message through the console:

```
The device is in Zero Touch Provisioning mode and is attempting to
download the startup-config from a remote system. The device will not
be fully functional until either a valid startup-config is downloaded
from a remote system or Zero Touch Provisioning is cancelled. To cancel
Zero Touch Provisioning, login as admin and type 'zerotouch cancel'
at the CLI.
```

```
localhost login:
```

Step 3 Log into the switch by typing **admin** at the login prompt.

```
localhost login:admin
```

Step 4 Cancel ZTP mode by typing **zerotouch cancel**. *IMPORTANT: This step initiates a switch reboot.*

```
localhost>zerotouch cancel
```

Step 5 After the switch boots, log into the switch again by typing **admin** at the login prompt.

```
Arista EOS
localhost login:admin
Last login: Fri Mar 15 13:17:13 on console
```

Step 6 Enter global configuration mode.

```
localhost>enable
localhost#config
```

Step 7 Assign a password to the *admin* username with the **username secret** command.

```
localhost (config)#username admin secret pxq123
```

Step 8 Configure a default route to the network gateway.

```
localhost (config)#ip route 0.0.0.0/0 192.0.2.1
```

Step 9 Assign an IP address (*192.0.2.8/24* in this example) to an Ethernet management port.

```
localhost (config)#interface management 1/1
localhost (config-if-Ma1/1)#ip address 192.0.2.8/24
```

Step 10 Save the configuration by typing **write memory** or **copy running-config startup-config**.

```
localhost#copy running-config startup-config
```

When the management port IP address is configured, use this command to access the switch from a host, using the address configured in step 9:

```
ssh admin@192.0.2.8
```

Refer to the **Arista Networks User Manual** for complete switch configuration information.

Appendix A Status Indicators

A.1 Supervisor Module

While the front panel of each switch can house two supervisors, switch operations require only one. Supervisors display switch component status and contain Ethernet management and console ports. Appendix D displays the supervisor location on each switch.

The supervisor provides one serial console port, two Ethernet management ports, two USB ports, and one clock input port. Supervisor activity is reported by LEDs in the lower left corner. Four LEDs located right of these LEDs report status of other switch components. Figure 19 displays the Supervisor Module.

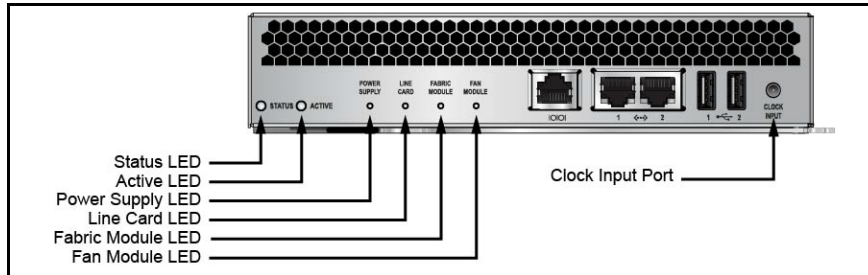

Figure 19: Supervisor Module

Supervisor Activity Status LEDs

Table 3 interprets the states of the Status and Active LEDs.

Table 3: Supervisor Activity LED States

LED Name	LED State	Supervisor State
Status	Off	Module failed or is improperly inserted.
	Green	Supervisor operating normally.
	Red	Module failed.
Active	Off	Supervisor is not active.
	Green	Supervisor is active and controlling the switch.

Component Activity Status LEDs

LEDs located below the vents and left of the input ports display summary indicators for power supplies, fabric modules, fan modules, and linecards. Table 4 interprets the states of these indicators. When error conditions are indicated, refer to LEDs on the specified modules to determine the condition's source.

Table 4: Component Activity LED States

LED Name	LED State	Module State
Power Supply	Off	No modules are present or powered.
Line Card	Green	All powered modules are operating normally.
Fabric Module	Red	At least one module has failed.
Fan Modules	Off	Module not inserted .
	Amber	At least one fan is missing or has failed.
	Green	All modules are operating normally.
	Red	There are insufficient functional fans installed in the switch.

A.2 Linecard Module Indicators

Each linecard module provides one status LED plus LEDs for each port on the card. The figures in Appendix F indicate the location of the LEDs on each linecard. Figure 20-left displays the status LED and Port LEDs on the left side of the DCS-7300X-64S-LC linecard. Figure 20-right displays the status LED and Port LEDs on the left side of the DCS-7300X-32Q-LC linecard.

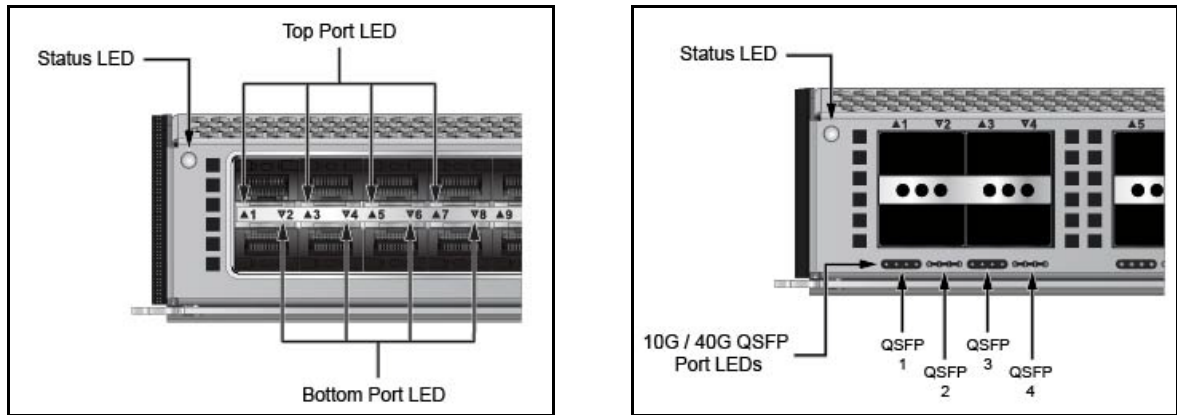

Figure 20: Linecard Status LEDs (DCS-7300X-LS and DCS-7300X-32Q-LC)

The Linecard Status LED is in the top left corner of the DCS-7300X-64S-LC linecard. Table 5 interprets the states of the Status LED.

Table 5: Linecard Status LED States

LED State	Status
Off	Linecard not inserted.
Green	Linecard operating normally.
Yellow	Linecard administratively shut down.
Red	Module has failed.

The linecard provides LEDs for each port module socket:

- Figure 20-left displays SFP module LEDs. Each LED corresponds to a module.
- Figure 20-right displays QSFP module LEDs. A set of four LEDs correspond to each module. When the module is programmed as a 40G port, the first LED in the set reports status. When the module is programmed as four 10G ports, each port is assigned to an LED within the set.

Table 6 interprets port LED states.

Table 6: Linecard Port LED States

LED State	Status
Off	Port link is down.
Green	Port link is up.
Yellow	Port is disabled in software.

A.3 Fan and Fabric Status Indicators

Fan and fabric modules are accessed from the rear panel. Fabric modules are inserted into the switch and fan modules are inserted into the fabric modules. Each switch contains four fabric modules; the fan module capacity of fabric modules varies by switch model, as displayed in Table 7

Table 7: Fan Module Capacity

Switch Model	Fabric Capacity	Switch Capacity
DCS-7304	2 fan modules	8 fan modules
DCS-7308	4 fan modules	16 fan modules
DCS-7316	8 fan modules	32 fan modules

Appendix E displays the rear panel of all switches covered by this guide. Figure 21 displays a DCS-7304-FM fabric module and the fan modules that it contains.

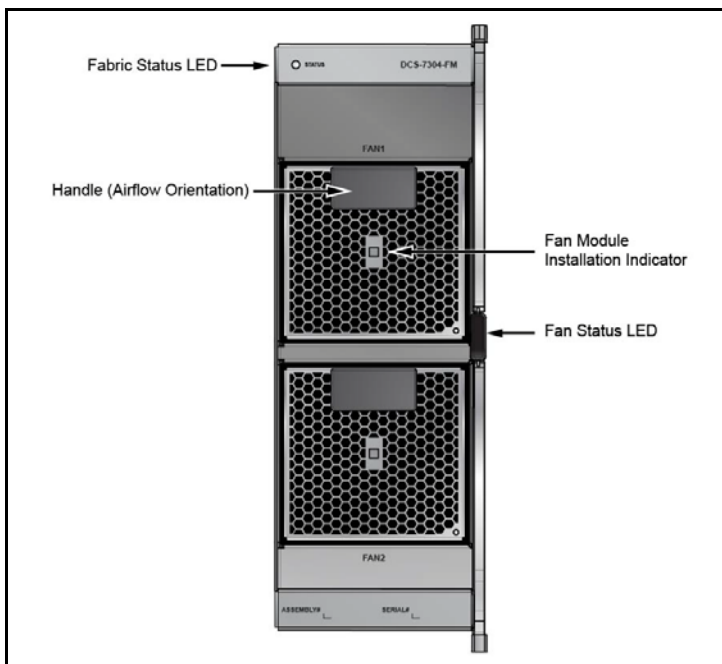

Figure 21: Fan Status and Fabric Status LEDs

Fan and fabric module indicators are displayed in Figure 21. The fan handle indicates the fan direction. All fan modules must have the same color handle.

The **fan module installation indicator** is green when the fan module is properly installed or red when the module is not fully installed. Table 8 interprets the states of the Fan and Fabric Status LEDs.

Table 8: Fan and Fabric Status LED States

LED State	Status
Off	The module is inserted but not receiving power – it may not be properly seated.
Green	The module is operating normally.
Red	The module has failed.

A.4 Power Supply Status Indicators

Power Supply LEDs are on power supply modules. The front panel contains power supply modules for all switches; the DCS-7316 rear panel may also contain power supply modules. Appendix D (front panels) and Appendix E (rear panels) displays the position of these LEDs on each switch.

Figure 22 display a power supply module.

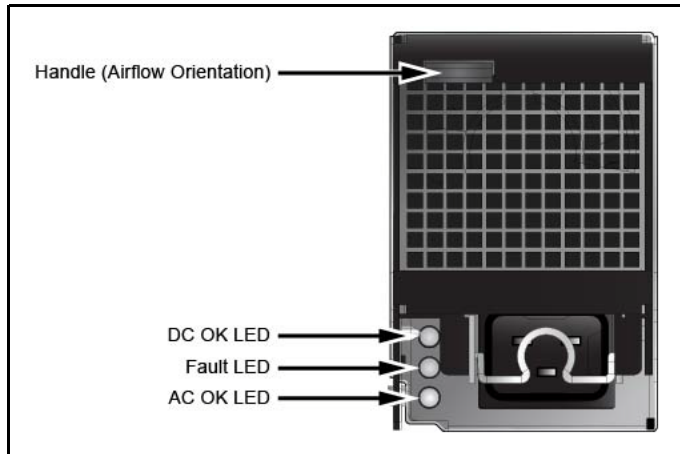

Figure 22: Power Supply

The power supply handle indicates the power supply fan direction. Verify the airflow direction of all modules satisfy these criteria:

- All rear panel modules (fan and power supply modules) have the same color handles.
- All front panel modules (power supply modules) have the same color handles.
- Rear panel modules and front panel modules have different color handles.

Table 9 interprets the states of the Power Supply Status LED.

Table 9: Power Supply Status

AC OK LED	Fault LED	DC OK LED	Status
Green	Off	Green	Power Supply module operating normally.
Green	Off	Off	AC is present, Main output is off.
Off	Off	Off	No AC power to the module.
Green	Amber Blinking	Off	Module has failed.

Appendix B Fabric Module Handling

Fabric modules are accessed from the rear panel. Each module includes lock-levers that secure it to the chassis. The module and the lock_levers are easily damaged by improperly removing, inserting, or handling the fabric module. The lock levers should never be used to lift or move the module after it is removed from the chassis.

Figure 23 displays a DCS-7316 chassis with the inner two fabric modules installed. The lock-levers are shown in the open and closed position, along with the button that releases them into the open position. The lock-levers are in the closed position when the switch is in service

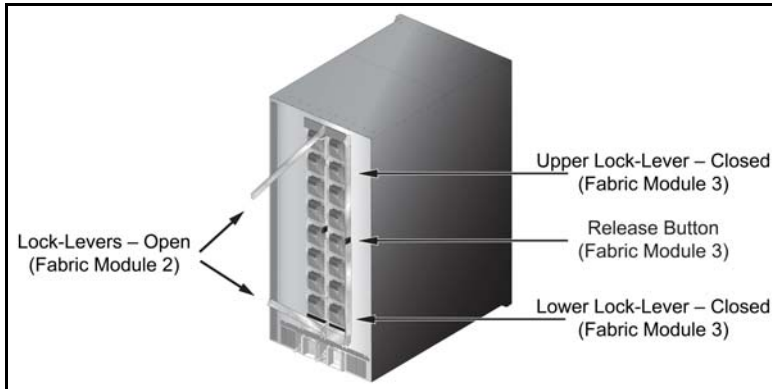

Figure 23: Fabric Module Locking Mechanisms

The following sections describe proper methods for removing fabric modules from the switch and inserting modules into the switch. Illustrations depict a DCS-7316 chassis and fabric modules. Although proper handling of these devices is imperative because of their size and weight, the instructions also describe best practices for handling DCS-7304 and DCS-7308 components.

B.1 Removing the Fabric Module

This procedure removes a fabric from the switch chassis.

Step 1 Press the release button on the module to be removed to release the lock-levers from the module frame. Figure 24-left displays the switch prior to pressing the release button.

Step 2 Extend the lock-levers towards the top and bottom of the chassis, as shown in Figure 24-right.

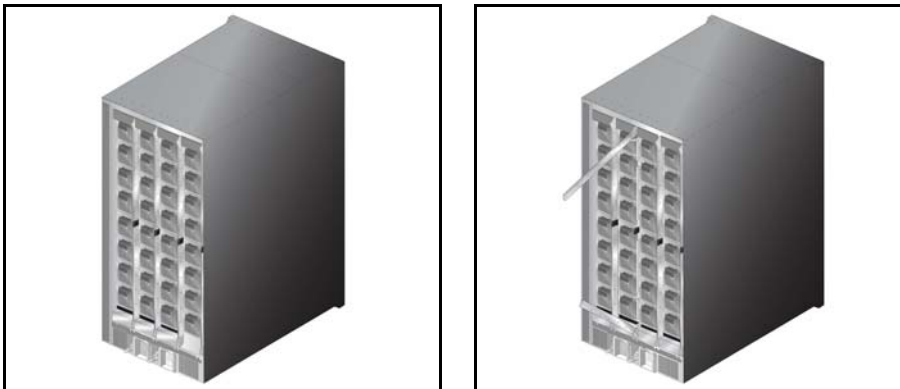

Figure 24: Fabric Module Removal: Initial Position and Opening the Lock-Levers

- Step 3** Use the lock-levers to pull the module three to four inches from the installed position (Figure 25-left).
- Step 4** Return the lock-levers to the closed position (Figure 25-right)

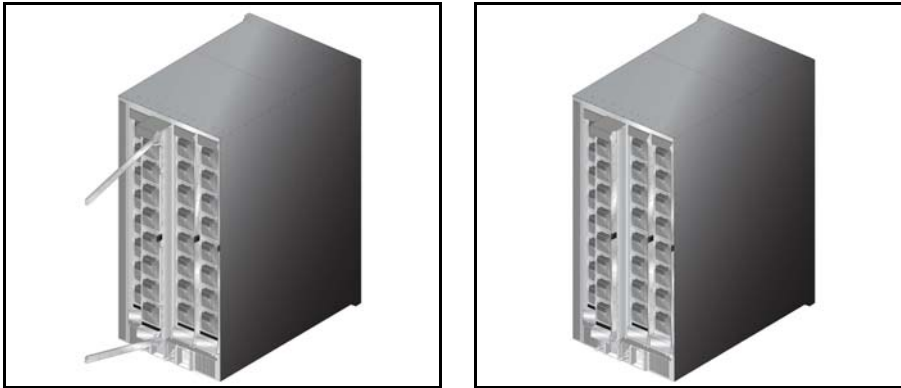

Figure 25: Fabric Module Removal: Edging the Module Out and Closing the Lock-Levers

- Step 5** Grasping the module frame, continue pulling the module until it is completely outside of the chassis.
- The DCS-7316 fabric module is almost three feet long and weighs close to 40 pounds. Use necessary precautions to safely manage the component outside of the chassis.

B.2 Inserting the Fabric Module

The fabric module insertion process is the inverse of the removal procedure. These instruction describe the method of inserting the fabric module into a chassis.

- Step 1** Grasping the module by its frame, place the module chassis railing that corresponds to the slot where it is to be placed. The lock-levers should be in the closed position.
- Step 2** Slide the module into the chassis until it's within three to four inches of being fully inserted (Figure 25-right).
- Step 3** Press the Release Button to release the lock-levers into the open position (Figure 25-left).
- Step 4** Continue inserting the module into the chassis. If other fabric modules are in the chassis, the module being installed should be in the same relative position (Figure 24-right).
- Return the lock-levers to the closed position, securing the module to the chassis (Figure 24-left).

Appendix C Parts List

Each switch provides an accessory kit that contains parts that are required to install the switch into a four-post rack. Two-post rack mount parts are available through your sales representative. The following sections list the installation parts provided by the accessory kit.

C.1 Four-Post Rack Mount Parts

Quantity	Description
2	Mounting Ears
1	Left shelf.
1	Right shelf.

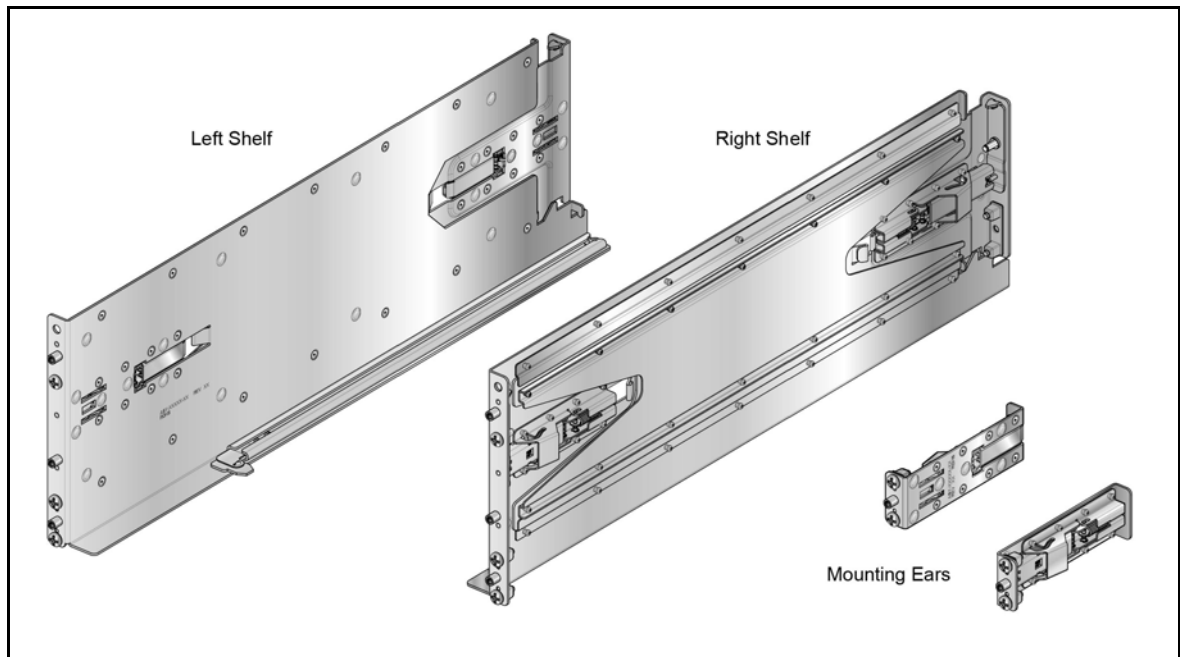

Figure 26: Four-Post Rack Mount Parts

C.2 Two-Post Rack Mount Parts

Two-post rack mount parts for DCS-7304 and DCS-7308 switches are available through your sales representative. Two-post rack mounts are not supported for DCS-7316 switches.

Quantity	Description
2	Center-mount brackets.
16 (DCS-7304) 20 (DCS-7308)	M4x8 panhead Phillips screws.

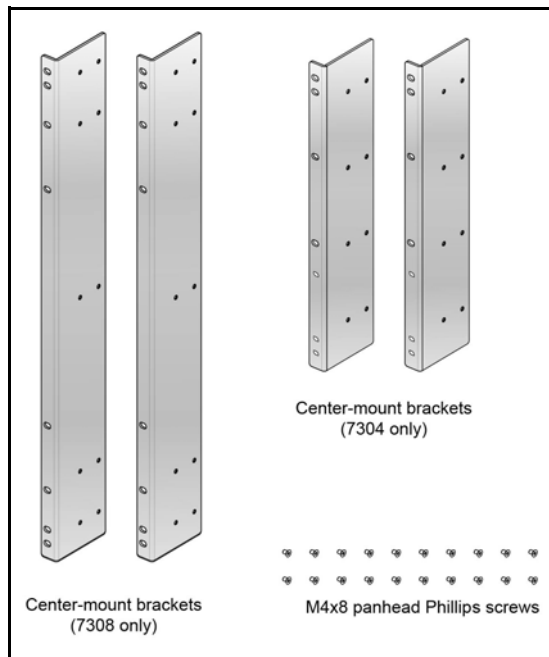

Figure 27: Two-Post Rack Mount Parts

C.3 Parts Used in All Rack Mount Configurations

Quantity	Description
One for each power supply module supplied with switch	power cables: 14 AWG, C19-C20, 2 meters.
1	RJ-45 Patch Panel Cables, 2 meters.
1	RJ-45 to DB9 Adapter Cable, 2 meters.

Warning! All provided power cables are for use only with Arista products.

警告

すべての電源コードは提供する製品で使用するためだけを目的としている。

電源コードの他の製品での使用の禁止

Arista が提供するすべての電源コードは、Arista の製品でのみ使用してください。

Appendix D Front Panels

This appendix displays the front panel of all switches covered by this guide.

DCS-7304 Front Panel (fully populated)

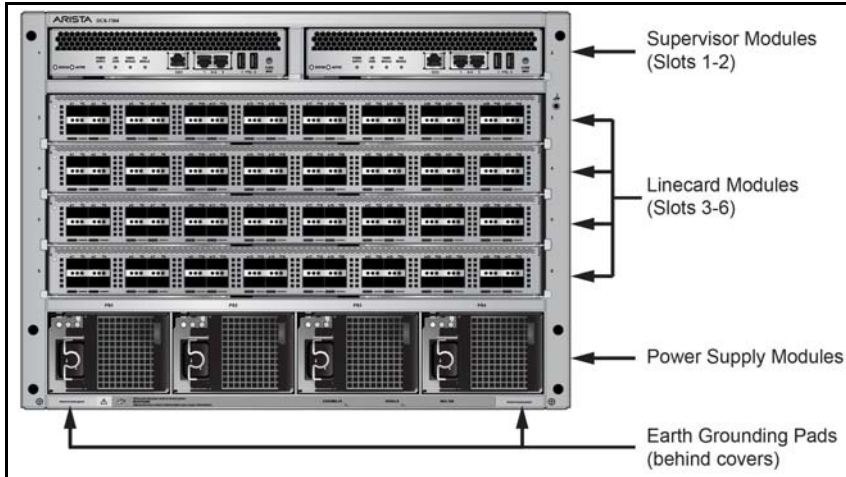

DCS-7308 Front Panel (fully populated)

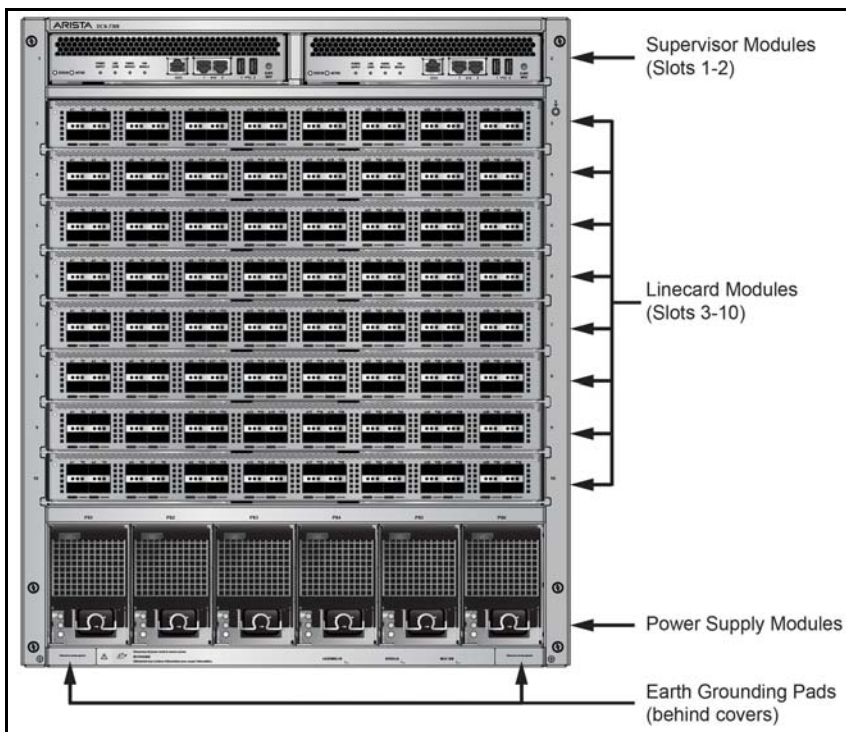

DCS-7316 Front Panel (fully populated)

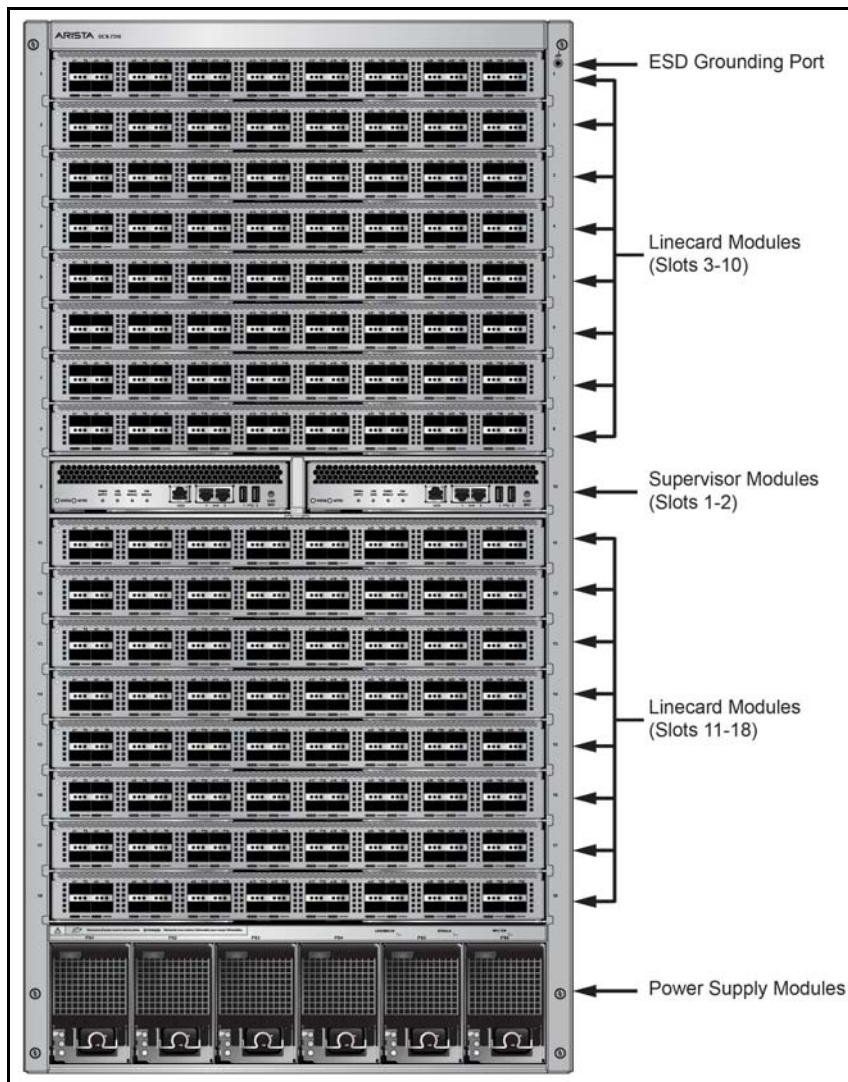

Appendix E Rear Panel

This appendix displays the rear panel of all switches covered by this guide.

DCS-7304 Rear Panel

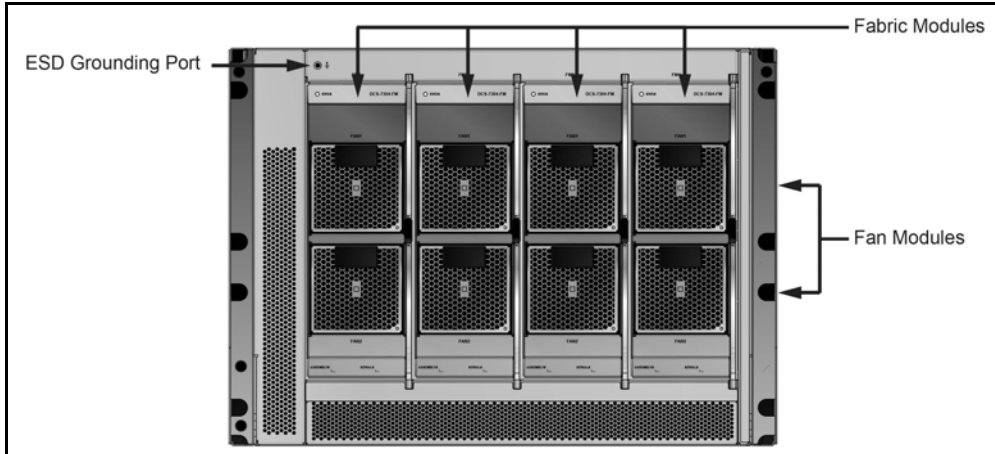

DCS-7308 Rear Panel

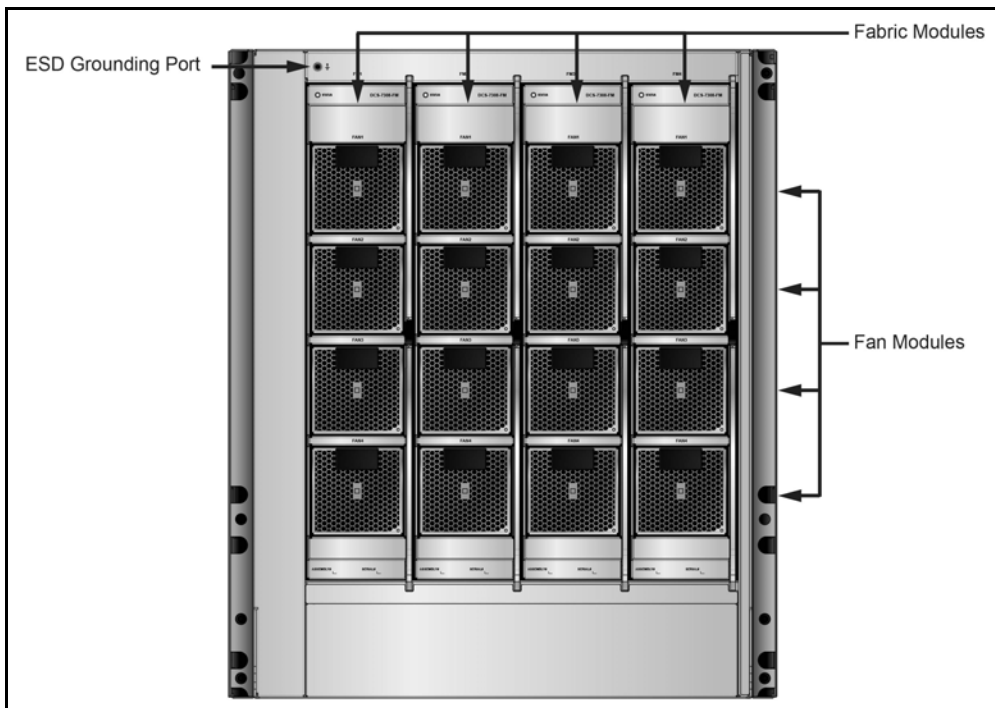

DCS-7316 Rear Panel

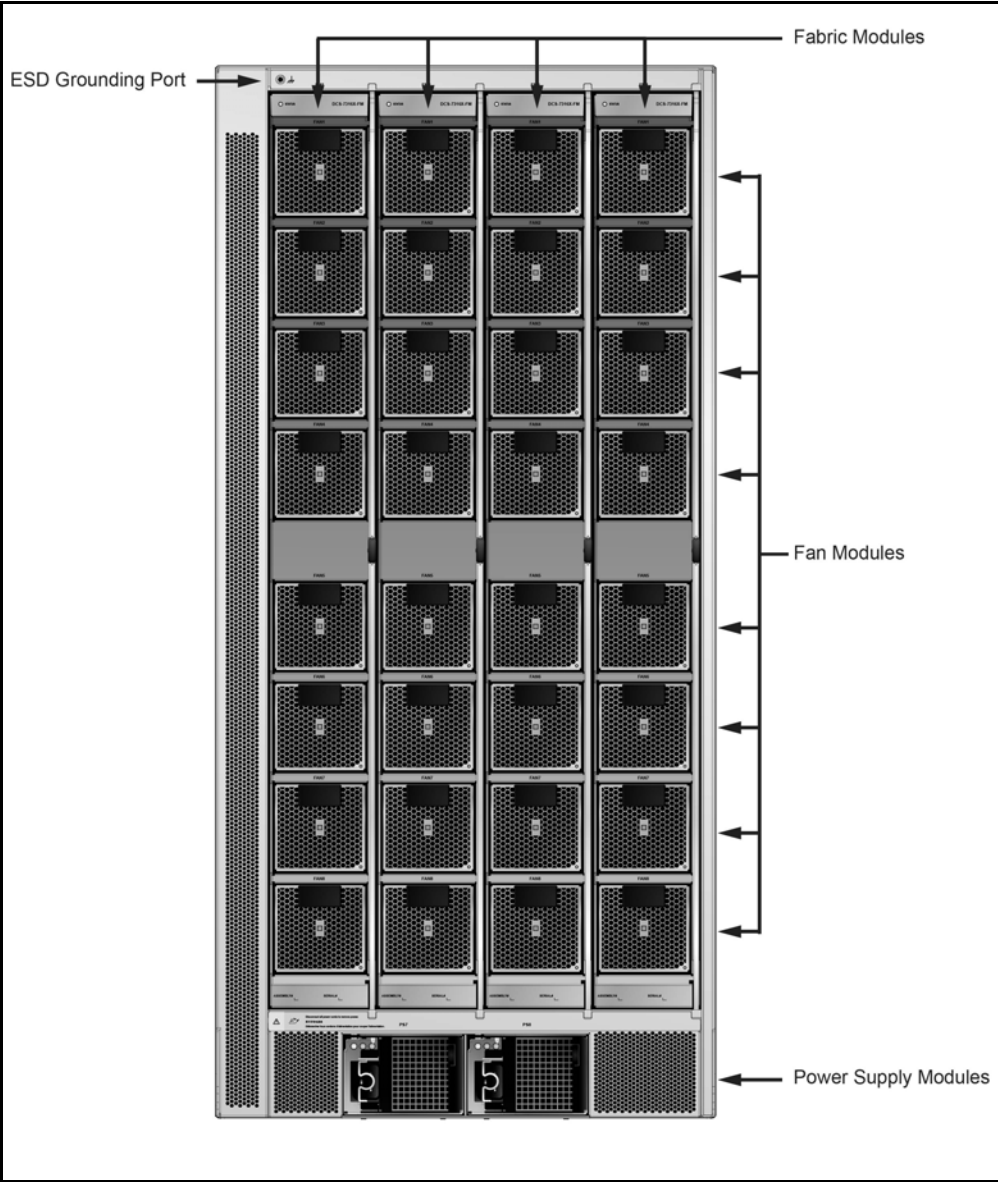

Appendix F Linecards

This appendix displays the linecards supported by modular switches covered by this guide.

DCS-7300X-32Q-LC

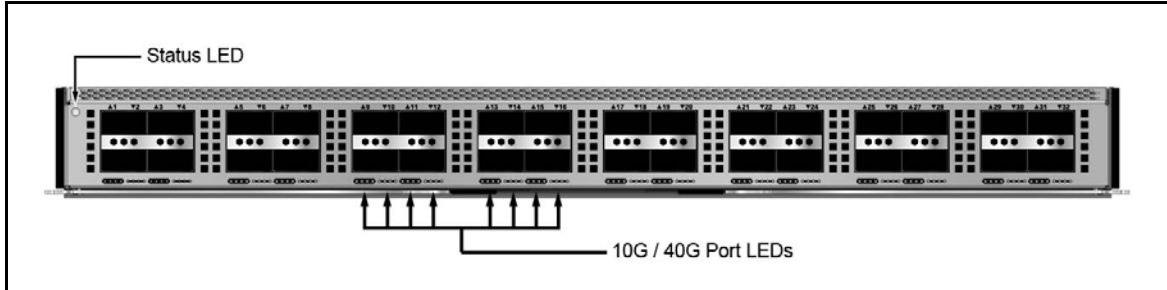

DCS-7300X-64S-LC

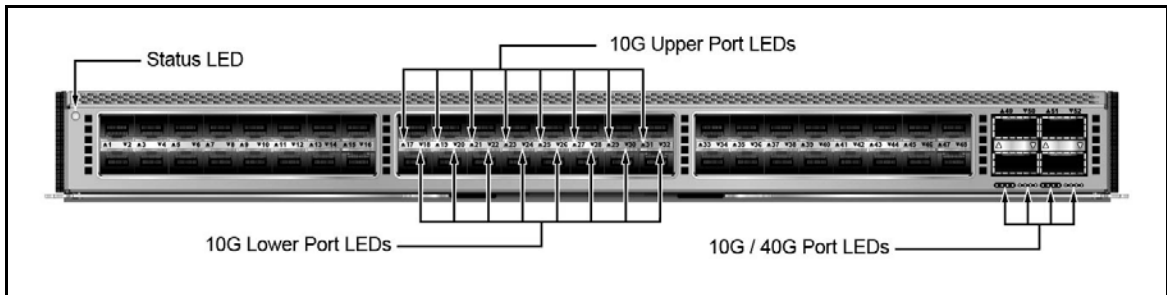

DCS-7300X-64T-LC

