



Cisco ASA 5510, ASA 5520, ASA 5540, and ASA 5550 Hardware Installation Guide

Americas Headquarters

Cisco Systems, Inc.
170 West Tasman Drive
San Jose, CA 95134-1706
USA
<http://www.cisco.com>
Tel: 408 526-4000
800 553-NETS (6387)
Fax: 408 527-0883

Customer Order Number: 78-17989-01
Text Part Number: 78-17989-01

THE SPECIFICATIONS AND INFORMATION REGARDING THE PRODUCTS IN THIS MANUAL ARE SUBJECT TO CHANGE WITHOUT NOTICE. ALL STATEMENTS, INFORMATION, AND RECOMMENDATIONS IN THIS MANUAL ARE BELIEVED TO BE ACCURATE BUT ARE PRESENTED WITHOUT WARRANTY OF ANY KIND, EXPRESS OR IMPLIED. USERS MUST TAKE FULL RESPONSIBILITY FOR THEIR APPLICATION OF ANY PRODUCTS.

THE SOFTWARE LICENSE AND LIMITED WARRANTY FOR THE ACCOMPANYING PRODUCT ARE SET FORTH IN THE INFORMATION PACKET THAT SHIPPED WITH THE PRODUCT AND ARE INCORPORATED HEREIN BY THIS REFERENCE. IF YOU ARE UNABLE TO LOCATE THE SOFTWARE LICENSE OR LIMITED WARRANTY, CONTACT YOUR CISCO REPRESENTATIVE FOR A COPY.

The following information is for FCC compliance of Class A devices: This equipment has been tested and found to comply with the limits for a Class A digital device, pursuant to part 15 of the FCC rules. These limits are designed to provide reasonable protection against harmful interference when the equipment is operated in a commercial environment. This equipment generates, uses, and can radiate radio-frequency energy and, if not installed and used in accordance with the instruction manual, may cause harmful interference to radio communications. Operation of this equipment in a residential area is likely to cause harmful interference, in which case users will be required to correct the interference at their own expense.

The following information is for FCC compliance of Class B devices: The equipment described in this manual generates and may radiate radio-frequency energy. If it is not installed in accordance with Cisco's installation instructions, it may cause interference with radio and television reception. This equipment has been tested and found to comply with the limits for a Class B digital device in accordance with the specifications in part 15 of the FCC rules. These specifications are designed to provide reasonable protection against such interference in a residential installation. However, there is no guarantee that interference will not occur in a particular installation.

Modifying the equipment without Cisco's written authorization may result in the equipment no longer complying with FCC requirements for Class A or Class B digital devices. In that event, your right to use the equipment may be limited by FCC regulations, and you may be required to correct any interference to radio or television communications at your own expense.

You can determine whether your equipment is causing interference by turning it off. If the interference stops, it was probably caused by the Cisco equipment or one of its peripheral devices. If the equipment causes interference to radio or television reception, try to correct the interference by using one or more of the following measures:

- Turn the television or radio antenna until the interference stops.
- Move the equipment to one side or the other of the television or radio.
- Move the equipment farther away from the television or radio.
- Plug the equipment into an outlet that is on a different circuit from the television or radio. (That is, make certain the equipment and the television or radio are on circuits controlled by different circuit breakers or fuses.)

Modifications to this product not authorized by Cisco Systems, Inc. could void the FCC approval and negate your authority to operate the product.

The Cisco implementation of TCP header compression is an adaptation of a program developed by the University of California, Berkeley (UCB) as part of UCB's public domain version of the UNIX operating system. All rights reserved. Copyright © 1981, Regents of the University of California.

NOTWITHSTANDING ANY OTHER WARRANTY HEREIN, ALL DOCUMENT FILES AND SOFTWARE OF THESE SUPPLIERS ARE PROVIDED "AS IS" WITH ALL FAULTS. CISCO AND THE ABOVE-NAMED SUPPLIERS DISCLAIM ALL WARRANTIES, EXPRESSED OR IMPLIED, INCLUDING, WITHOUT LIMITATION, THOSE OF MERCHANTABILITY, FITNESS FOR A PARTICULAR PURPOSE AND NONINFRINGEMENT OR ARISING FROM A COURSE OF DEALING, USAGE, OR TRADE PRACTICE.

IN NO EVENT SHALL CISCO OR ITS SUPPLIERS BE LIABLE FOR ANY INDIRECT, SPECIAL, CONSEQUENTIAL, OR INCIDENTAL DAMAGES, INCLUDING, WITHOUT LIMITATION, LOST PROFITS OR LOSS OR DAMAGE TO DATA ARISING OUT OF THE USE OR INABILITY TO USE THIS MANUAL, EVEN IF CISCO OR ITS SUPPLIERS HAVE BEEN ADVISED OF THE POSSIBILITY OF SUCH DAMAGES.

Cisco and the Cisco logo are trademarks or registered trademarks of Cisco and/or its affiliates in the U.S. and other countries. To view a list of Cisco trademarks, go to this URL: www.cisco.com/go/trademarks. Third-party trademarks mentioned are the property of their respective owners. The use of the word partner does not imply a partnership relationship between Cisco and any other company. (1110R)

Cisco ASA 5510, ASA 5520, ASA 5540, and ASA 5550 Hardware Installation Guide
©2009-2012 Cisco Systems, Inc. All rights reserved.



About This Guide

This preface includes the following sections:

- [Document Objectives, page 1](#)
- [Audience, page 1](#)
- [Document Organization, page 1](#)
- [Document Conventions, page 2](#)
- [Installation Warnings, page 2](#)
- [Obtaining Documentation and Submitting a Service Request, page 6](#)

Document Objectives

This guide describes how to perform installation and maintenance procedures on the Cisco ASA 5500 Series Adaptive Security Appliances. The information in this guide applies to the following Cisco ASA 5500 Series Adaptive Security Appliance models: Cisco ASA 5510, Cisco ASA 5520, Cisco ASA 5540, and Cisco ASA 5550. In this guide, references to "Cisco ASA 5500 Series Adaptive Security Appliance" and "adaptive security appliance" apply to all models unless specifically noted otherwise.

Audience

This guide is for network administrators who perform any of the following tasks:

- Managing network security
- Installing and configuring firewalls
- Managing default and static routes, and TCP and UDP services

Document Organization

This guide includes the following chapters and appendices:

- [Chapter 1, "Overview"](#) describes the product and the memory requirements.
- [Chapter 1, "Preparing for Installation,"](#) describes the steps to follow before installing new hardware or performing hardware upgrades.

- [Chapter 1, “Installing the Adaptive Security Appliance,”](#) describes how to install the chassis on the wall or rack and how to connect the interface cables on the adaptive security appliance.
- [Chapter 1, “Maintenance and Upgrade Procedures,”](#) describes how to remove and replace the chassis cover, the lithium battery in the SSM, the power supply, the CompactFlash, and the SSMs.
- [Appendix 1, “Cable Pinouts,”](#) describes the cable pinouts.

Document Conventions

Command descriptions use these conventions:

- Braces ({ }) indicate a required choice.
- Square brackets ([]) indicate optional elements.
- Vertical bars (|) separate alternative, mutually exclusive elements.
- **Boldface** indicates commands and keywords that are entered literally as shown.
- *Italics* indicate arguments for which you supply values.

Examples use these conventions:

- Examples depict screen displays and the command line in *screen* font.
- Information you need to enter in examples is shown in **boldface screen** font.
- Variables for which you must supply a value are shown in *italic screen* font.

Graphical user interface examples uses these conventions:

- **Boldface** indicates buttons and menu items.
- Selecting a menu item (or pane) is indicated by the following convention:
Choose **Start > Settings > Control Panel**.



Note

Means *reader take note*. Notes contain helpful suggestions or references to material not covered in the manual.

Installation Warnings

Be sure to read the *Regulatory Compliance and Safety Information for the Cisco ASA 5500 Series* document that accompanied this device before installing the chassis. This document contains important safety information. This section includes the following warnings:

- [Power Supply Disconnection Warning, page 3](#)
- [Jewelry Removal Warning, page 3](#)
- [Wrist Strap Warning, page 3](#)
- [Work During Lightning Activity Warning, page 3](#)
- [Installation Instructions Warning, page 3](#)
- [Chassis Warning for Rack-Mounting and Servicing, page 4](#)
- [Short-Circuit Protection Warning, page 4](#)
- [SELV Circuit Warning, page 4](#)

- [Ground Conductor Warning, page 4](#)
- [Blank Faceplates and Cover Panels Warning, page 4](#)
- [Product Disposal Warning, page 4](#)
- [Short-Circuit Protection Warning, page 5](#)
- [Compliance with Local and National Electrical Codes Warning, page 5](#)
- [DC Power Connection Warning, page 5](#)
- [AC Power Disconnection Warning, page 5](#)
- [TN Power Warning, page 5](#)
- [48 VDC Power System, page 5](#)
- [Multiple Power Cord, page 5](#)
- [Circuit Breaker \(15A\) Warning, page 5](#)
- [Grounded Equipment Warning, page 6](#)
- [Safety Cover Requirement, page 6](#)
- [Faceplates and Cover Panel Requirement, page 6](#)

Power Supply Disconnection Warning



Warning

Before working on a chassis or working near power supplies, unplug the power cord on AC units; disconnect the power at the circuit breaker on DC units. Statement 12

Jewelry Removal Warning



Warning

Before working on equipment that is connected to power lines, remove jewelry (including rings, necklaces, and watches). Metal objects will heat up when connected to power and ground and can cause serious burns or weld the metal object to the terminals. Statement 43

Wrist Strap Warning



Warning

During this procedure, wear grounding wrist straps to avoid ESD damage to the card. Do not directly touch the backplane with your hand or any metal tool, or you could shock yourself. Statement 94

Work During Lightning Activity Warning



Warning

Do not work on the system or connect or disconnect cables during periods of lightning activity. Statement 1001

Installation Instructions Warning



Warning

Read the installation instructions before connecting the system to the power source. Statement 1004

Chassis Warning for Rack-Mounting and Servicing



Warning

To prevent bodily injury when mounting or servicing this unit in a rack, you must take special precautions to ensure that the system remains stable. The following guidelines are provided to ensure your safety: This unit should be mounted at the bottom of the rack if it is the only unit in the rack. When mounting this unit in a partially filled rack, load the rack from the bottom to the top with the heaviest component at the bottom of the rack. If the rack is provided with stabilizing devices, install the stabilizers before mounting or servicing the unit in the rack. Statement 1006

Short-Circuit Protection Warning



Warning

This product requires short-circuit (overcurrent) protection, to be provided as part of the building installation. Install only in accordance with national and local wiring regulations. Statement 1045

SELV Circuit Warning



Warning

To avoid electric shock, do not connect safety extra-low voltage (SELV) circuits to telephone-network voltage (TNV) circuits. LAN ports contain SELV circuits, and WAN ports contain TNV circuits. Some LAN and WAN ports both use RJ-45 connectors. Use caution when connecting cables. Statement 1021

Ground Conductor Warning



Warning

This equipment must be grounded. Never defeat the ground conductor or operate the equipment in the absence of a suitably installed ground conductor. Contact the appropriate electrical inspection authority or an electrician if you are uncertain that suitable grounding is available. Statement 1024

Blank Faceplates and Cover Panels Warning



Warning

Blank faceplates and cover panels serve three important functions: they prevent exposure to hazardous voltages and currents inside the chassis; they contain electromagnetic interference (EMI) that might disrupt other equipment; and they direct the flow of cooling air through the chassis. Do not operate the system unless all cards, faceplates, front covers, and rear covers are in place. Statement 1029

Product Disposal Warning



Warning

Ultimate disposal of this product should be handled according to all national laws and regulations. Statement 1040

Short-Circuit Protection Warning



This product requires short-circuit (overcurrent) protection, to be provided as part of the building installation. Install only in accordance with national and local wiring regulations. Statement 1045

Compliance with Local and National Electrical Codes Warning



Installation of the equipment must comply with local and national electrical codes. Statement 1074

DC Power Connection Warning



After wiring the DC power supply, remove the tape from the circuit breaker switch handle and reinstate power by moving the handle of the circuit breaker to the ON position. Statement 8

AC Power Disconnection Warning



Before working on a chassis or working near power supplies, unplug the power cord on AC units. Statement 246

TN Power Warning



The device is designed to work with TN power systems. Statement 19

48 VDC Power System



The customer 48 volt power system must provide reinforced insulation between the primary AC power and the 48 VDC output. Statement 128

Multiple Power Cord



This unit has more than one power cord. To reduce the risk of electric shock when servicing a unit, disconnect the power cord of the power strip that the unit is plugged into. Statement 137

Circuit Breaker (15A) Warning



This product relies on the building's installation for short-circuit (overcurrent) protection. Ensure that a fuse or circuit breaker no larger than 120 VAC, 15A U.S. (240 VAC, 10A international) is used on the phase conductors (all current-carrying conductors). Statement 13

Grounded Equipment Warning



Warning

This equipment is intended to be grounded. Ensure that the host is connected to earth ground during normal use. Statement 39

Safety Cover Requirement



Warning

The safety cover is an integral part of the product. Do not operate the unit without the safety cover installed. Operating the unit without the cover in place will invalidate the safety approvals and pose a risk of fire and electrical hazards. Statement 117

Faceplates and Cover Panel Requirement



Warning

Blank faceplates and cover panels serve three important functions: they prevent exposure to hazardous voltages and currents inside the chassis; they contain electromagnetic interference (EMI) that might disrupt other equipment; and they direct the flow of cooling air through the chassis. Do not operate the system unless all cards, faceplates, front covers, and rear covers are in place. Statement 142

Where to Find Safety and Warning Information

For safety and warning information, see the *Regulatory Compliance and Safety Information for the Cisco ASA 5500 Series* document that accompanied the product. This document describes the international agency compliance and safety information for the Cisco ASA 5500 Series Adaptive Security Appliance. It also includes translations of the safety warnings.

Obtaining Documentation and Submitting a Service Request

For information on obtaining documentation, using the Cisco Bug Search Tool (BST), submitting a service request, and gathering additional information, see [What's New in Cisco Product Documentation](#).

To receive new and revised Cisco technical content directly to your desktop, you can subscribe to the [What's New in Cisco Product Documentation RSS feed](#). The RSS feeds are a free service.



1 CHAPTER

Overview

Read through the entire guide before beginning any of the procedures in this book.



Warning

Only trained and qualified personnel should install, replace, or service this equipment. Statement 49



Caution

Read the safety warnings in the *Regulatory Compliance and Safety Information for the Cisco ASA 5500 Series* and follow proper safety procedures when performing these steps.

This chapter describes the product and the memory requirements, and includes the following topics:

- [Product Overview, page 1-2](#)
- [Memory Requirements, page 1-5](#)
- [Memory Kits, page 1-6](#)
- [Memory Requirements for Software Version 8.3 and Later, page 1-6](#)



Note

The illustrations in this chapter show the Cisco ASA 5540 adaptive security appliance. The Cisco ASA 5510 and Cisco ASA 5520 adaptive security appliance look identical, containing the same back panel features and indicators. The Cisco ASA 5550 has a fixed configuration with an embedded 4GE slot as shown in [Figure 1-3](#).

Product Overview

This section describes the front and rear panels. [Figure 1-1](#) shows the front panel LEDs.

Figure 1-1 Front Panel LEDs

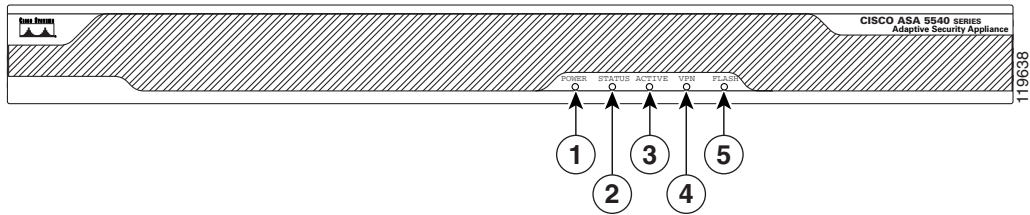

	LED	Color	State	Description
1	Power	Green	On	The system has power.
2	Status	Green	Flashing	The power-up diagnostics are running or the system is booting.
			Solid	The system has passed power-up diagnostics.
			Amber	Solid
3	Active	Green	Solid	This unit is the Active unit in the failover pair.
			Amber	Solid
4	VPN	Green	Solid	A VPN tunnel has been established.
5	Flash	Green	Solid	The CompactFlash is being accessed.

[Figure 1-2](#) shows the rear panel.

Figure 1-2 Rear Panel LEDs and Ports (AC Power Supply Model Shown)

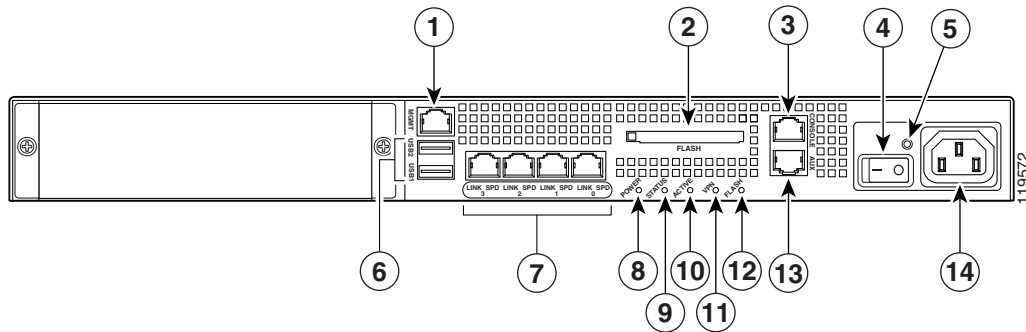

1	Management port ¹	6	USB 2.0 interfaces ²	11	VPN LED
2	External CompactFlash slot	7	Network interfaces ³	12	Flash LED
3	Serial Console port	8	Power indicator LED	13	AUX port ⁴
4	Power switch	9	Status indicator LED	14	Power connector
5	Power indicator LED	10	Active LED		

1. The management 0/0 interface is a Fast Ethernet interface designed for management traffic only.
2. Not supported at this time.

- GigabitEthernet interfaces, from right to left, GigabitEthernet 0/0, GigabitEthernet 0/1, GigabitEthernet 0/2, and GigabitEthernet 0/3.
- The RJ-45 Auxiliary port (labeled AUX on the chassis) is reserved for internal use at Cisco. The port is not functional in shipping versions of the chassis; therefore, customers cannot connect to this port to run the adaptive security appliance CLI.

For more information about the Management port, see the **management only** command in the *Cisco Security Appliance Command Reference*.

The Cisco ASA 5550 has a fixed configuration with an embedded 4GE slot as shown in [Figure 1-3](#).

Figure 1-3 Rear Panel LEDs and Ports for the Cisco ASA 5550

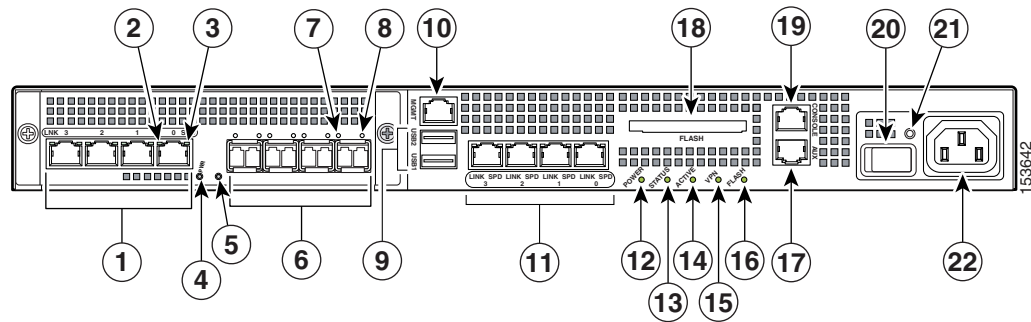

1	RJ-45 ports ¹	9	USB 2.0 interfaces ²	17	AUX port
2	RJ-45 Link LED	10	Management port ³	18	External CompactFlash slot
3	RJ-45 Speed LED	11	Network interfaces ⁴	19	Serial Console port
4	Power LED	12	Power indicator LED	20	Power switch
5	Status LED	13	Status indicator LED	21	Power indicator LED
6	SFP ports ⁵	14	Active LED	22	Power connector
7	SFP Link LED	15	VPN LED		
8	SFP Speed LED	16	Flash LED		

- GigabitEthernet ports, from right to left, GigabitEthernet 1/0, GigabitEthernet 1/1, GigabitEthernet 1/2, and GigabitEthernet 1/3
- Not supported at this time.
- The management 0/0 interface is a Fast Ethernet interface intended for management traffic only.
- GigabitEthernet interfaces, from right to left, GigabitEthernet 0/0, GigabitEthernet 0/1, GigabitEthernet 0/2, and GigabitEthernet 0/3.
- SFP ports, from right to left, GigabitEthernet 1/0, GigabitEthernet 1/1, GigabitEthernet 1/2, and GigabitEthernet 1/3

[Table 1-1](#) describes the 4GE SSM LEDs.

Table 1-1 4GE SSM LEDs for the Cisco ASA 5550

	LED	Color	State	Description
2, 7	LINK	Green	Solid	There is an Ethernet link.
			Flashing	There is Ethernet activity.

Table 1-1 4GE SSM LEDs (continued) for the Cisco ASA 5550

	LED	Color	State	Description
3, 8	SPEED	Off	10 MB	There is no network activity.
		Green	100 MB	There is network activity at 100 Mbps.
		Amber	1000 MB (GigE)	There is network activity at 1000 Mbps.
4	POWER	Green	On	The system has power.
5	STATUS	Green	Flashing	The system is booting.
		Green	Solid	The system booted correctly.
		Amber	Solid	The system diagnostics failed.

Figure 1-4 shows the adaptive security appliance rear panel LEDs.

Figure 1-4 Rear Panel Link and Speed Indicator LEDs

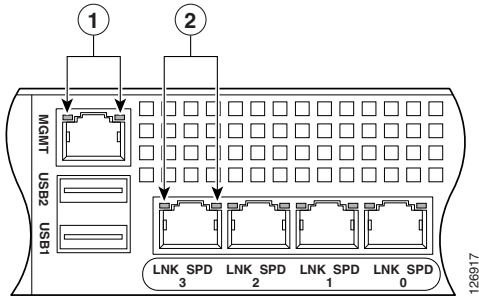

1	MGMT indicator LEDs	2	Network interface LEDs
---	---------------------	---	------------------------

Table 1-2 lists the rear MGMT and Network interface LEDs.

Table 1-2 Link and Speed LEDs

Indicator	Color	Description
Left side	Solid green	Physical link
	Green flashing	Network activity
Right side	Not lit	10 Mbps
	Green	100 Mbps
	Amber	1000 Mbps



Note

The Cisco ASA 5510 adaptive security appliance supports only 10/100BaseTX. The Cisco ASA 5520 and the Cisco ASA 5540 support 1000BaseT.

Memory Requirements

Table 1-3 lists the standard and recommended flash memory and DRAM. Note that the shipping DRAM increased after February 2010; the DRAM requirements for 8.3 and higher match the newer default shipping sizes. See [Memory Kits, page 1-6](#) for the information to order an upgrade kit. The newer default shipping DRAM is the current maximum DRAM you can install in your unit.

Table 1-3 Standard Memory Requirements for the Cisco ASA Series

ASA Model	Internal Flash Memory (Default Shipping) ^{1,2}	DRAM (Default Shipping)	
		Before Feb. 2010	After Feb. 2010 (Required for 8.3 and Higher)
5510	256 MB	256 MB	1 GB
5520	256 MB	512 MB	2 GB
5540	256 MB	1 GB	2 GB
5550	256 MB	4 GB	4GB

1. For the ASA 5510 through 5550, you might need to upgrade the internal flash memory to 512 MB or add external flash memory if you load multiple images of the AnyConnect client along with one or more images of the ASA software, ASDM, client/server plugins, or Cisco Secure Desktop. In particular, you might need to upgrade for multiple AnyConnect 3.0 and higher clients with optional modules. The ASA 5505 does not have a flash memory upgrade available.
2. The default internal flash memory for some models was 64 MB in the past; if you have one of these early units, we recommend upgrading your flash memory to at least the new shipping default.

In a failover configuration, the two units must have the same hardware configuration. They must be the same model, have the same number and types of interfaces, and the same amount of RAM.



Note

The two units do not have to have the same amount of flash memory. If using units with different flash memory sizes in your failover configuration, make sure the unit with the smaller flash memory has enough space to accommodate the software image files and the configuration files. If it does not, configuration synchronization from the unit with the larger flash memory to the unit with the smaller flash memory will fail.

For more information, see the *Cisco Security Appliance Command Line Configuration Guide*.

Memory Kits

Table 1-4 lists the available DRAM (DIMM) kits.

Table 1-4 **DRAM Kits**

Model	Size	Part Number
ASA 5510 ¹	1 GB	ASA5510-MEM-1GB=
ASA 5520	2 GB	ASA5520-MEM-2GB=
ASA 5540	2 GB	ASA5540-MEM-2GB=
ASA 5550	4 GB	2 x ASA5540-MEM-2GB=

1. If you previously purchased the 512 MB upgrade kit for the ASA 5510 (ASA5510-MEM-512=), you must upgrade to the 1 GB memory upgrade kit to run Version 8.3.

Table 1-5 lists the CompactFlash upgrade kits available for the ASA 5510 through ASA 5550, for use as internal or external flash memory.

Table 1-5 **CompactFlash Upgrade Kits**

Model	Size	Part Number
ASA 5510 through ASA 5550	256 MB	ASA5500-CF-256MB=
ASA 5510 through ASA 5550	512 MB	ASA5500-CF-512MB=

Memory Requirements for Software Version 8.3 and Later

For information on memory requirements for the adaptive security appliance for software Version 8.3 or later, go to: http://www.cisco.com/en/US/prod/collateral/vpndevc/ps6032/ps6094/ps6120/product_bulletin_c25-586414.html



CHAPTER 1

Preparing for Installation

The information in this guide applies to the following Cisco ASA 5500 series Adaptive Security Appliance models: Cisco ASA 5510, Cisco ASA 5520, Cisco ASA 5540, and Cisco ASA 5550. In this guide, references to “Cisco ASA 5500 series Adaptive Security Appliance” and “adaptive security appliance” apply to all models unless specifically noted otherwise.

This chapter describes the steps to follow before installing new hardware or performing hardware upgrades, and includes the following sections:

- [Overview, page 1-1](#)
- [Installation Overview, page 1-1](#)
- [Safety Recommendations, page 1-2](#)
- [General Site Requirements, page 1-4](#)

Overview

The adaptive security appliance delivers unprecedented levels of defense against threats to the network with deeper web inspection and flow-specific analysis, improved secure connectivity via end-point security posture validation, and voice and video over VPN support. It also provides enhanced support for intelligent information networks through improved network integration, resiliency, and scalability.

The adaptive security appliance software combines firewall, VPN concentrator, and intrusion prevention software functionality into one software image. Previously, these functions were available in three separate devices, each with its own software and hardware. Combining the functionality into just one software image provides significant improvements in the available features.

Additionally, the Cisco ASA 5500 series Adaptive Security Appliance software supports Adaptive Security Device Manager. ASDM is a browser-based, Java applet used to configure and monitor the software on the adaptive security appliances. ASDM is loaded from the adaptive adaptive security appliance, then used to configure, monitor, and manage the device.

Installation Overview

To prepare for the installation of the chassis, perform the following steps:

-
- Step 1** Review the safety precautions outlined in the *Regulatory Compliance and Safety Information for the Cisco ASA 5500 Series* document.

- Step 2** Read the release notes for the respective software version.
- Step 3** Unpack the chassis. An accessory kit ships with the chassis and includes the following items: documentation, a product CD, a power cord (AC models only), two RJ-45 Ethernet cables, one RJ-45 to DB-9 console cable, a rack-mounting kit, and four self-adhesive feet (for desktop mounting).
- Step 4** Place the chassis on a stable work surface.
-

Safety Recommendations

Use the following guidelines and the information in the following sections to help ensure your safety and protect the adaptive security appliance. The list of guidelines may not address all potentially hazardous situations in your working environment, so be alert and exercise good judgement at all times.



Note

If you need to remove the chassis cover to install a hardware component, such as additional memory or an interface card, doing so does not affect your Cisco warranty. Upgrading the adaptive security appliance does not require any special tools and does not create any radio frequency leaks.

The safety guidelines are as follows:

- Keep the chassis area clear and dust-free before, during and after installation.
- Keep tools away from walk areas where you and others could fall over them.
- Do not wear loose clothing or jewelry, such as earrings, bracelets, or chains, that could get caught in the chassis.
- Wear safety glasses if you are working under any conditions that might be hazardous to your eyes.
- Do not perform any action that creates a potential hazard to people or makes the equipment unsafe.
- Never attempt to lift an object that is too heavy for one person to handle.

This section includes the following topics:

- [Maintaining Safety with Electricity, page 1-2](#)
- [Preventing Electrostatic Discharge Damage, page 1-3](#)

Maintaining Safety with Electricity



Warning

Before working on a chassis or working near power supplies, unplug the power cord on AC units; disconnect the power at the circuit breaker on DC units. Statement 12

Follow these guidelines when working on equipment powered by electricity:

- Before beginning procedures that require access to the interior of the chassis, locate the emergency power-off switch for the room in which you are working. Then, if an electrical accident occurs, you can act quickly to turn off the power.
- Do not work alone if potentially hazardous conditions exist anywhere in your work space.
- Never assume that power is disconnected from a circuit; always check the circuit.

- Look carefully for possible hazards in your work area, such as moist floors, ungrounded power extension cables, frayed power cords, and missing safety grounds.
- If an electrical accident occurs, proceed as follows:
 - Use caution; do not become a victim yourself.
 - Disconnect power from the system.
 - If possible, send another person to get medical aid. Otherwise, assess the condition of the victim and then call for help.
 - Determine if the person needs rescue breathing or external cardiac compressions; then take appropriate action.
- Use the adaptive security appliance chassis within its marked electrical ratings and product usage instructions.
- Install the adaptive security appliance in compliance with local and national electrical codes as listed in the *Regulatory Compliance and Safety Information for the Cisco ASA 5500 Series* document.
- The adaptive security appliance models equipped with AC-input power supplies are shipped with a 3-wire electrical cord with a grounding-type plug that fits only a grounding-type power outlet. Do not circumvent this safety feature. Equipment grounding should comply with local and national electrical codes.
- The adaptive security appliance models equipped with DC-input power supplies must be terminated with the DC input wiring on a DC source capable of supplying at least 15 amps. A 15-amp circuit breaker is required at the 48 VDC facility power source. An easily accessible disconnect device should be incorporated into the facility wiring. Be sure to connect the grounding wire conduit to a solid earth ground. We recommend that you use a closed loop ring to terminate the ground conductor at the ground stud. The DC return connection to this system is to remain isolated from the system frame and chassis.

Other DC power guidelines are listed in the *Regulatory Compliance and Safety Information for the Cisco ASA 5500 Series* document.

Preventing Electrostatic Discharge Damage

Electrostatic discharge (ESD) can damage equipment and impair electrical circuitry. ESD damage occurs when electronic components are improperly handled and can result in complete or intermittent failures.

- Always follow ESD-prevention procedures when removing and replacing components. Ensure that the chassis is electrically connected to earth ground. Wear an ESD-preventive wrist strap, ensuring that it makes good skin contact. Connect the grounding clip to an unpainted surface of the chassis frame to safely ground ESD voltages. To properly guard against ESD damage and shocks, the wrist strap and cord must operate effectively. If no wrist strap is available, ground yourself by touching the metal part of the chassis.
- For safety, periodically check the resistance value of the antistatic strap, which should be between 1 and 10 megohms (Mohms).

General Site Requirements

The topics in this section describe the requirements your site must meet for safe installation and operation of your system. Ensure that your site is properly prepared before beginning installation.

This section includes the following topics:

- [Site Environment, page 1-4](#)
- [Preventive Site Configuration, page 1-4](#)
- [Power Supply Considerations, page 1-4](#)
- [Configuring Equipment Racks, page 1-7](#)

Site Environment

Place the chassis on a desktop or mount it on a rack. The location of the chassis and the layout of the equipment rack or wiring room are extremely important for proper system operation. Equipment placed too close together, inadequate ventilation, and inaccessible panels can cause system malfunctions and shutdowns, and can make the chassis maintenance difficult.

For information on physical specifications, see table 7 at the following url:

http://www.cisco.com/en/US/prod/collateral/vpndevc/ps6032/ps6094/ps6120/product_data_sheet0900aec802930c5.html

When planning the site layout and equipment locations, keep in mind the precautions described in the next section “[Preventive Site Configuration, page 1-4](#),” to help avoid equipment failures and reduce the possibility of environmentally caused shutdowns. If you are currently experiencing shutdowns or unusually high error rates with your existing equipment, these precautions may help you isolate the cause of failures and prevent future problems.

Preventive Site Configuration

The following precautions will help plan an acceptable operating environment for the chassis and avoid environmentally caused equipment failures:

- Electrical equipment generates heat. Ambient air temperature might not be adequate to cool equipment to acceptable operating temperatures without adequate circulation. Ensure that the room in which you operate your system has adequate air circulation.
- Always follow the ESD-prevention procedures described previously to avoid damage to equipment. Damage from static discharge can cause immediate or intermittent equipment failure.
- Ensure that the chassis top panel is secure. The chassis is designed to allow cooling air to flow effectively within it. An open chassis allows air leaks, which may interrupt and redirect the flow of cooling air from the internal components.

Power Supply Considerations

For information on power supply considerations including environmental operating ranges and power requirements, see table 7 at the following url:

http://www.cisco.com/en/US/prod/collateral/vpndevc/ps6032/ps6094/ps6120/product_data_sheet0900aec802930c5.html

The following chassis models can have either an AC or DC power supply: Cisco ASA 5510, Cisco ASA 5520, Cisco ASA 5540, and Cisco ASA 5550.

Observe the following considerations:

- Check the power at the site before installing the chassis to ensure that the power is “clean” (free of spikes and noise). Install a power conditioner if necessary, to ensure proper voltages and power levels in the source voltage.
- Install proper grounding for the site to avoid damage from lightning and power surges.
- In a chassis equipped with an AC-input power supply, use the following guidelines:
 - The chassis does not have a user-selectable operating range. Refer to the label on the chassis for the correct AC-input power requirement.
 - Several styles of AC-input power supply cords are available; make sure you have the correct style for your site.
 - Install an uninterruptible power source for your site, if possible.
 - Install proper site grounding facilities to guard against damage from lightning or power surges.
- In a chassis equipped with a DC-input power supply, use the following guidelines:
 - Each DC-input power supply requires dedicated 3-5 amp service.
 - For DC power cables, we recommend a minimum of 14 AWG wire cable.
 - The DC return connection to this system is to remain isolated from the system frame and chassis.

You will also need to provide power to the switch with the appropriate AC power cord for your location. [Table 1-1](#) lists the power cords that are used with the AC power supply.

Table 1-1 AC-Input Power Cord Options





Locale	Part Number	Length	Plug Rating	Plug Type
Appliance Coupler				
300 W AC Power Supply				 120352
North America	CAB-AC (72-0259)	8.2 ft (2.5 m)	125 VAC, 10 A	 120354
Australia,	CAB-ACA (72-0746-01)	8.2 ft (2.5 m)	250 VAC, 10 A	 120356
Europe (except Italy)	CAB-ACE (72-0460)	8.2 ft (2.5 m)	250 VAC, 10 A	 120357

Table 1-1 AC-Input Power Cord Options (continued)

Locale	Part Number	Length	Plug Rating	Plug Type
Italy	CAB-ACI 72-0556	8.2 ft (2.5 m)	250 VAC, 10 A	 120358
Singapore United Kingdom	CAB-ACU 72-0557	8.2 ft (2.5 m)	250 VAC, 10 A	 120359
Argentina	CAB-ACR (37-0995-01)	8.2 ft (2.5 m)	250 VAC, 10 A	 120356
Switzerland	CAB-ACS (72-1483-01)	8.2 ft (2.5 m)	250 VAC, 10 A	 251247
Japan	CAB-JPN (72-1925-01)	8.2 ft (2.5 m)	250 VAC, 10 A	 251248
India	CAB-IND-10A (37-0863-01)	8.2 ft (2.5 m)	250 VAC, 10 A	 331705
South Africa	AIR-PWR-CORD-SA (37-0346-01)	8.2 ft (2.5 m)	250 VAC, 10 A	 331706

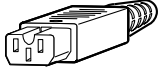
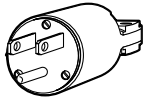
Configuring Equipment Racks

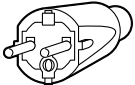
For information on physical specifications, see table 7 at the following url:

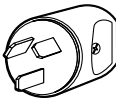
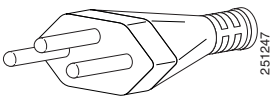
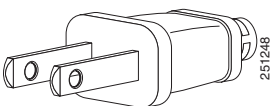
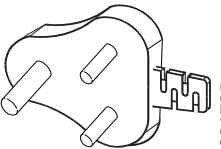
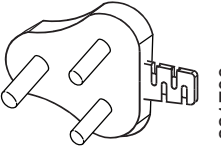
http://www.cisco.com/en/US/prod/collateral/vpndevc/ps6032/ps6094/ps6120/product_data_sheet0900aec802930c5.html.

The following tips help you plan an acceptable equipment rack configuration:

- Enclosed racks must have adequate ventilation. Ensure that the rack is not overly congested, because each chassis generates heat. An enclosed rack should have louvered sides and a fan to provide cooling air.
- When mounting a chassis in an open rack, ensure that the rack frame does not block the intake or exhaust ports. If the chassis is installed on slides, check the position of the chassis when it is seated all the way into the rack.
- In an enclosed rack with a ventilation fan in the top, excessive heat generated by equipment near the bottom of the rack can be drawn upward and into the intake ports of the equipment above it in the rack. Ensure that you provide adequate ventilation for equipment at the bottom of the rack.
- Baffles can help to isolate exhaust air from intake air, which also helps to draw cooling air through the chassis. The best placement of the baffles depends on the airflow patterns in the rack. Experiment with different arrangements to position the baffles effectively.



CHAPTER 1

Installing the Adaptive Security Appliance

Installing the Adaptive Security Appliance

This section describes how to rack-mount and install the adaptive security appliance. You can mount the adaptive security appliance in a 19-inch rack (with a 17.5- or 17.75-inch opening).



Warning

To prevent bodily injury when mounting or servicing this unit in a rack, you must take special precautions to ensure that the system remains stable. The following guidelines are provided to ensure your safety: This unit should be mounted at the bottom of the rack if it is the only unit in the rack. When mounting this unit in a partially filled rack, load the rack from the bottom to the top with the heaviest component at the bottom of the rack. If the rack is provided with stabilizing devices, install the stabilizers before mounting or servicing the unit in the rack. Statement 1006

The following information can help plan equipment rack installation:

- Allow clearance around the rack for maintenance.
- If the rack contains stabilizing devices, install the stabilizers prior to mounting or servicing the unit in the rack.
- When mounting a device in an enclosed rack, ensure adequate ventilation. Do not overcrowd an enclosed rack. Make sure that the rack is not congested, because each unit generates heat.
- When mounting a device in an open rack, make sure that the rack frame does not block the intake or exhaust ports.
- If the rack contains only one unit, mount the unit at the bottom of the rack.
- If the rack is partially filled, load the rack from the bottom to the top, with the heaviest component at the bottom of the rack.

This section contains the following topics:

- [Rack-Mounting the Chassis, page 1-2](#)
- [Setting the Chassis on a Desktop, page 1-3](#)
- [Connecting the Interface Cables, page 1-4](#)

Rack-Mounting the Chassis

Use the mounting brackets to mount the chassis to the front or the back of the rack, with the front panel or the rear panel of the chassis facing outward. The part number for ordering a rack-mount kit for the Cisco ASA 5510, Cisco ASA 5520, Cisco ASA 5540, and Cisco ASA 5550 is ASA5500-HW=. To rack-mount the chassis, perform the following steps:

- Step 1** Attach the rack-mount brackets to the chassis using the supplied screws. Attach the brackets to the holes as shown in [Figure 1-1](#). After the brackets are secured to the chassis, you can rack-mount it.



Note [Figure 1-1](#) shows the rack mounting brackets attached to the rear of the chassis while [Figure 1-2](#) shows the rack mounting brackets attached to the front of the chassis. You can attach the mounting brackets to the front or the rear of the chassis so that you can have the front panel or the rear panel of the chassis facing outward. [Figure 1-1](#) shows the brackets attached to the rear so you can see how that configuration appears while [Figure 1-2](#) shows the brackets attached to the front so that you can see how that configuration appears. In [Step 1](#) and [Step 2](#), you will choose to have either the brackets rear mounted or front mounted but not both.

Figure 1-1 Installing the Right and Left Brackets

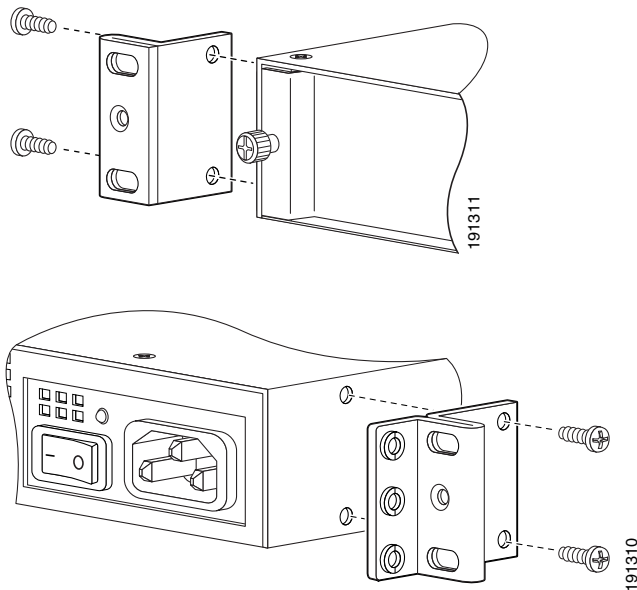

- Step 2** Attach the chassis to the rack using the supplied screws, as shown in [Figure 1-2](#).

Figure 1-2 Rack-Mounting the Chassis

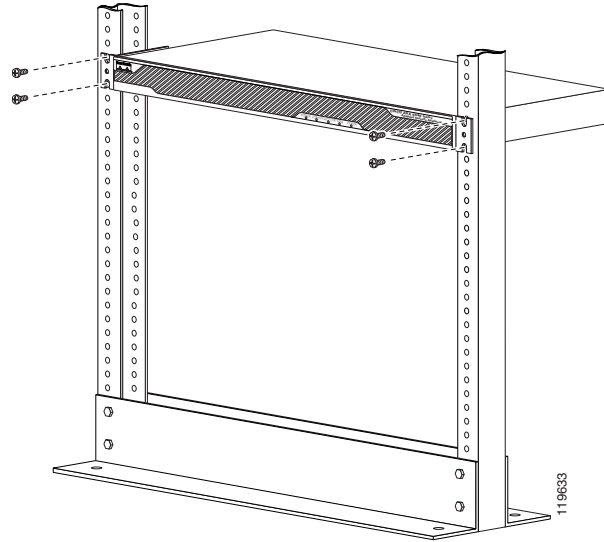

To remove the chassis from the rack, remove the screws that attach the chassis to the rack, and then remove the chassis.

Setting the Chassis on a Desktop

To set the chassis on a desktop, perform the following steps:

- Step 1** Locate the rubber feet on the black adhesive strip that shipped with the chassis.

Figure 1-3 Identifying the Rubber Feet

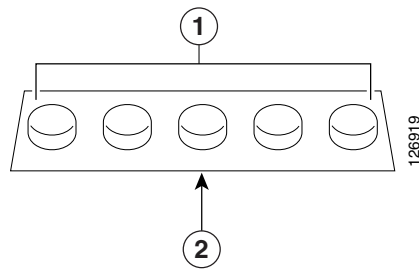

1	Rubber feet	2	Black adhesive strip
---	-------------	---	----------------------

- Step 2** Place the chassis upside down, on a smooth, flat surface.
- Step 3** Peel off the rubber feet from the black adhesive strip and press them adhesive-side down onto the bottom four corners of the chassis, see [Figure 1-4](#).

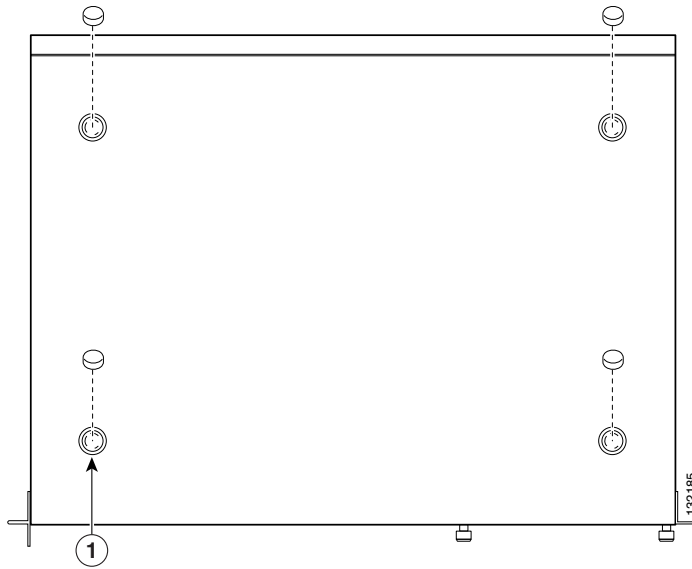
Figure 1-4 Attaching the Rubber Feet

1	Rubber feet
----------	-------------

- Step 4** Place the chassis right-side up on a flat, smooth, secure surface.
- Step 5** Connect the interface cables. See the [“Connecting the Interface Cables”](#) section on page 1-4 for more information.

Connecting the Interface Cables

This section describes how to connect the cables to the Console, Management, 4GE SSM, and SSM ports. In this document, SSM refers to an intelligent SSM, the AIP SSM or CSC SSM.



Note

You can use any unused Ethernet interface on the device as the failover link. The failover link interface is not configured as a normal networking interface; it should only be used for the failover link. You can connect the LAN-based failover link by using a dedicated switch with no hosts or routers on the link or by using a crossover Ethernet cable to link the units directly. For more information, see the *Cisco Security Appliance Command Line Configuration Guide*.



Warning

Only trained and qualified personnel should install, replace, or service this equipment. Statement 49



Caution

Read the safety warnings in the Regulatory Compliance and Safety Information for the Cisco ASA 5505 Adaptive Security Appliance and follow proper safety procedures when performing these steps.

**Note**

The RJ-45 Auxiliary port (labeled AUX on the chassis) is reserved for internal use at Cisco. The port is not functional in shipping versions of the chassis; therefore, customers cannot connect to this port to run the adaptive security appliance CLI.

To connect cables to the ports perform the following steps:

- Step 1** Place the chassis on a flat, stable surface, or in a rack (if you are rack-mounting it.)
- Step 2** Before connecting a computer or terminal to the ports, check to determine the baud rate of the serial port. The baud rate must match the default baud rate (9600 baud) of the Console port of the adaptive security appliance. Set up the terminal as follows: 9600 baud (default), 8 data bits, no parity, 1 stop bits, and Flow Control (FC) = Hardware.
- Step 3** Connect the cables to the ports.

a. Management port

The adaptive security appliance has a dedicated management interface referred to as the Management0/0 port. The Management0/0 port is a Fast Ethernet interface with a dedicated port used only for traffic management.

**Note**

You can configure any interface to be a management-only interface using the **management-only** command. You can also disable management-only mode on the management interface. For more information about this command, see the **management-only** command in the *Cisco Security Appliance Command Reference*.

- Connect one RJ-45 connector to the Management0/0 port, as shown in [Figure 1-5](#).
- Connect the other end of the Ethernet cable to the management port on your computer or network device.

Figure 1-5 Connecting to the Management Port

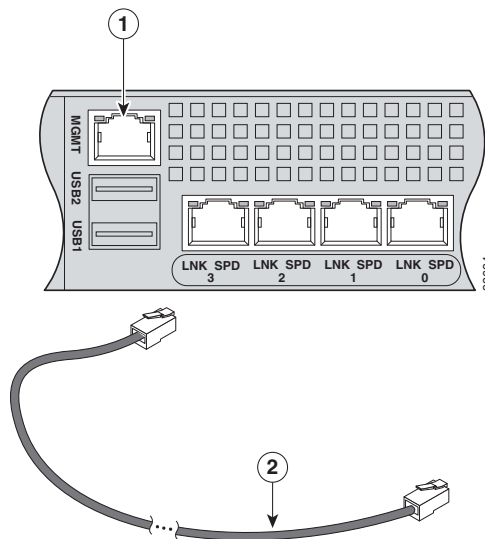

1	Management port	2	RJ-45 to RJ-45 Ethernet cable
----------	-----------------	----------	-------------------------------

b. Console port

- Connect the serial console cable as shown in [Figure 1-6](#). The console cable has a DB-9 connector on one end for the serial port on your computer, and the other end is an RJ-45 connector.
- Connect the RJ-45 connector to the Console port on the adaptive security appliance.
- Connect the other end of the cable, the DB-9 connector, to the console port on your computer.

Figure 1-6 Connecting to the Console Cable

1	RJ-45 Console port	2	RJ-45 to DB-9 console cable
----------	--------------------	----------	-----------------------------

- c. 4GE SSM
 - Ethernet port
 - Connect one RJ-45 connector to the Ethernet port of the 4GE SSM.
 - Connect the other end of the Ethernet cable to your network device, such as a router, switch or hub.



Note The 4GE SSM is optional, this connection is necessary only if you have installed the 4GE SSM on the adaptive security appliance.

Figure 1-7 Connecting to the RJ-45 port

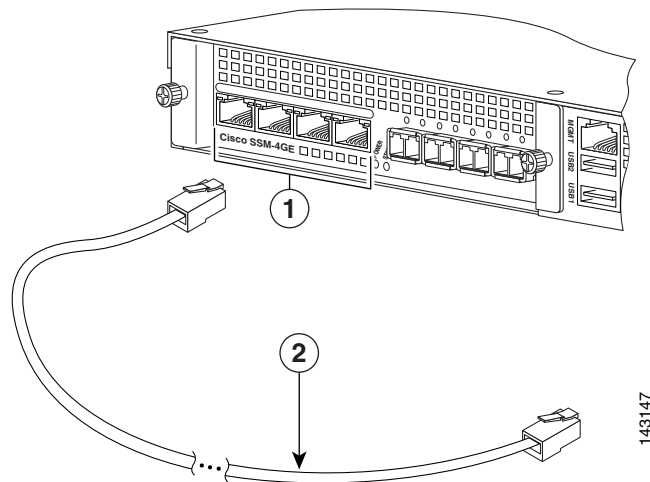

1	Ethernet ports	2	RJ-45 connector
---	----------------	---	-----------------



Note

When using the 4GE SSM you can use the same numbered copper ports (RJ-45) and the SFP ports at the same time. Use the **media-type** command in interface configuration mode to set the media type to copper or fiber Gigabit Ethernet. For a complete description of the command syntax, see the *Cisco ASA 5500 Series Command Reference*.

- SFP modules
 - Insert and slide the SFP module into the SFP port until you hear a click. The click indicates that the SFP module is locked into the port.
 - Remove the optical port plugs from the installed SFP as shown in [Figure 1-8](#).

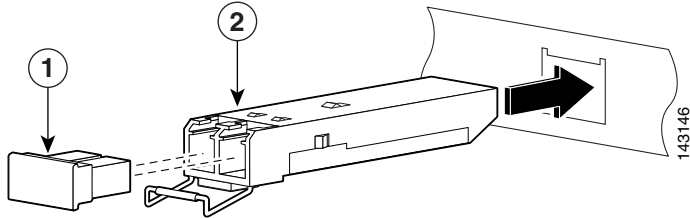
Figure 1-8 Removing the Optical Port Plug

1	Optical port plug	2	SFP module
---	-------------------	---	------------

- Connect the LC connector to the SFP module as shown in [Figure 1-9](#).

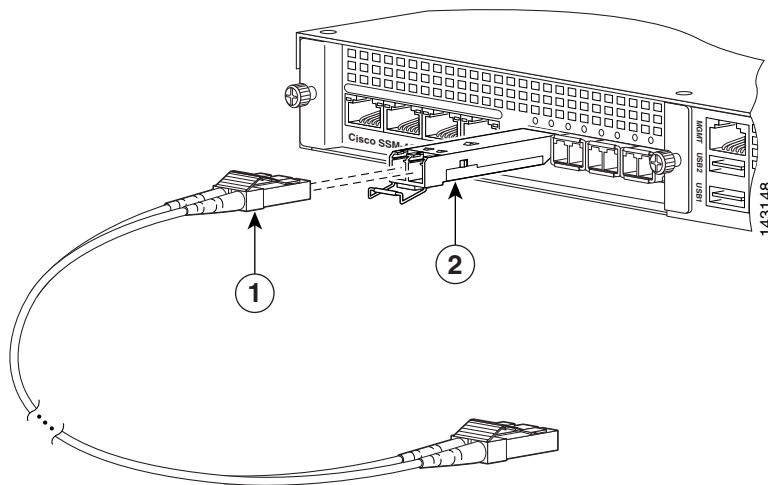
Figure 1-9 Connecting the LC Connector

1	LC connector	2	SFP module
---	--------------	---	------------

- Connect the other end to your network devices, such as routers, switches, or hubs.

- d. SSM
- Connect one RJ-45 connector to the management port on the SSM, as shown in [Figure 1-10](#).
 - Connect the other end of the RJ-45 cable to your network devices.



Note SSMs are optional, this connection is necessary only if you have installed an SSM on the adaptive security appliance.

Figure 1-10 Connecting to the Management Port

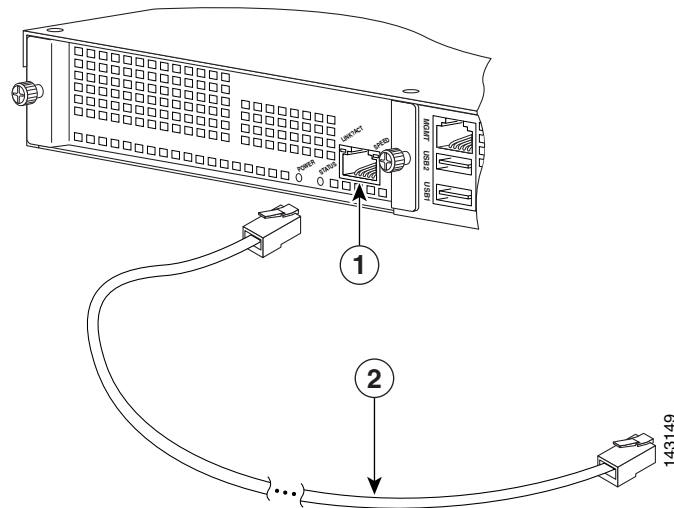

1	SSM management port	2	RJ-45 to RJ-45 cable
----------	---------------------	----------	----------------------

e. Ethernet ports

- Connect the RJ-45 connector to the Ethernet port.
- Connect the other end of the Ethernet cable to your network device, such as a router, switch or hub.

Figure 1-11 Connecting Cables to Network Interfaces

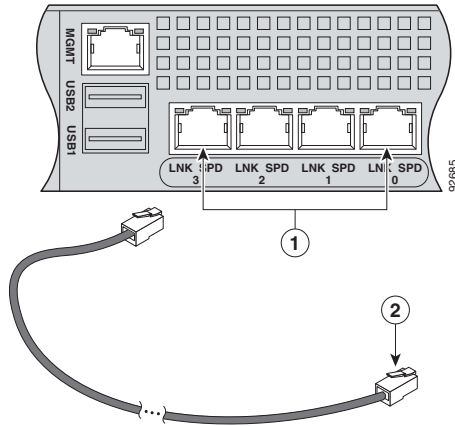

1	RJ-45 Ethernet ports	2	RJ-45 connector
----------	----------------------	----------	-----------------

Step 4 Connect the power cord to the adaptive security appliance and plug the other end to the power source. For information on powering on a DC model, see the [“Installing the DC Model”](#) section on page 1-7.

Step 5 Power on the chassis.



CHAPTER 1

Maintenance and Upgrade Procedures

This chapter describes how to, remove and replace the chassis cover, the power supply, and the CompactFlash. This chapter includes the following sections:

- [Removing and Replacing the Chassis Cover, page 1-1](#)
- [Working in an ESD Environment, page 1-3](#)
- [Removing and Replacing a Lithium Battery in the SSM, page 1-4](#)
- [Removing and Replacing the Power Supply, page 1-4](#)
- [Installing the DC Model, page 1-7](#)
- [Removing and Replacing the CompactFlash, page 1-10](#)
- [Installing and Replacing the 4GE SSM, page 1-14](#)
- [Installing and Replacing the Intelligent SSM, page 1-20](#)
- [Replacing Memory in the Adaptive Security Appliance, page 1-23](#)

Removing and Replacing the Chassis Cover

This section describes how to remove and replace the chassis cover. This section includes the following topics:

- [Removing the Chassis Cover, page 1-1](#)
- [Replacing the Chassis Cover, page 1-2s](#)

Removing the Chassis Cover

To remove the chassis cover, perform the following steps:

**Note**

Removing the chassis cover does not affect Cisco warranty. Upgrading the adaptive security appliance does not require any special tools and does not create any radio frequency leaks.

Step 1 Read the *Regulatory Compliance and Safety Information for the Cisco ASA 5500 Series* document.

Step 2 Power off the adaptive security appliance. Once the upgrade is complete, you can safely power on the chassis.

**Warning**

Before working on a system that has an On/Off switch, turn **OFF** the power and unplug the power cord.
Statement 1

Step 3 Remove the screws from the top of the chassis (Figure 1-1).

Figure 1-1 Removing the Top Panel Screws

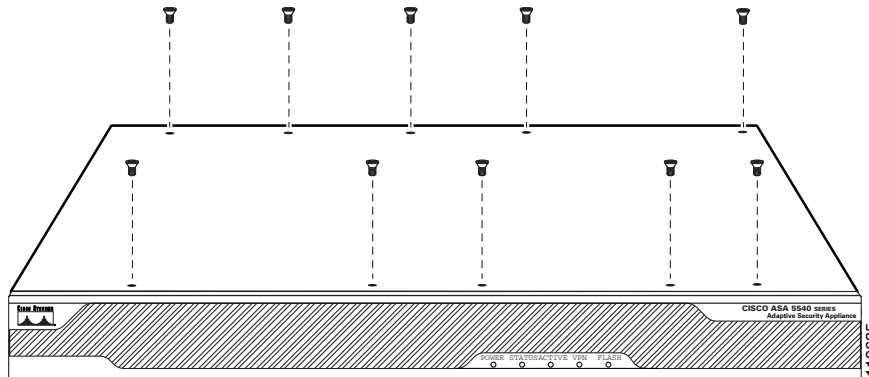

Step 4 Pull the top panel up as shown in Figure 1-2. Put the panel in a safe place.

Figure 1-2 Removing the Chassis Cover

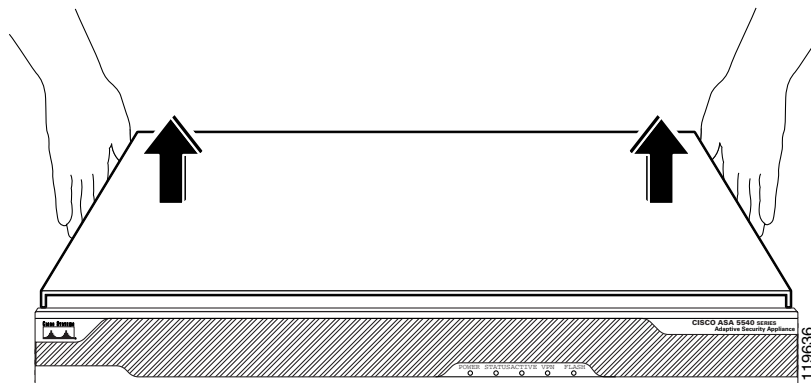

Replacing the Chassis Cover

**Caution**

Do not operate the adaptive security appliance without the chassis cover installed. The chassis cover protects the internal components, prevents electrical shorts, and provides proper air-flow for cooling the electronic components.

To replace the chassis cover, perform the following steps:

Step 1 Place the chassis on a secure surface with the front panel facing you.

- Step 2** Hold the top panel so the tabs at the rear of the top panel are aligned with the chassis bottom.
- Step 3** Lower the front of the top panel onto the chassis as shown in [Figure 1-3](#).

Figure 1-3 Replacing the Chassis Cover

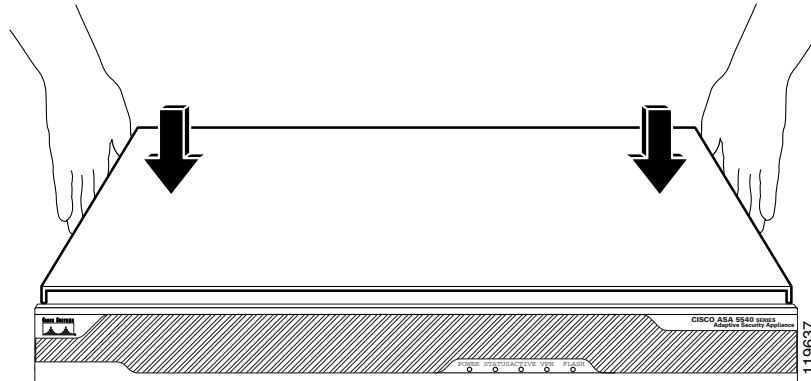

- Step 4** Fasten the top panel with the screws you set aside earlier as shown in [Figure 1-4](#).

Figure 1-4 Replacing the Screws

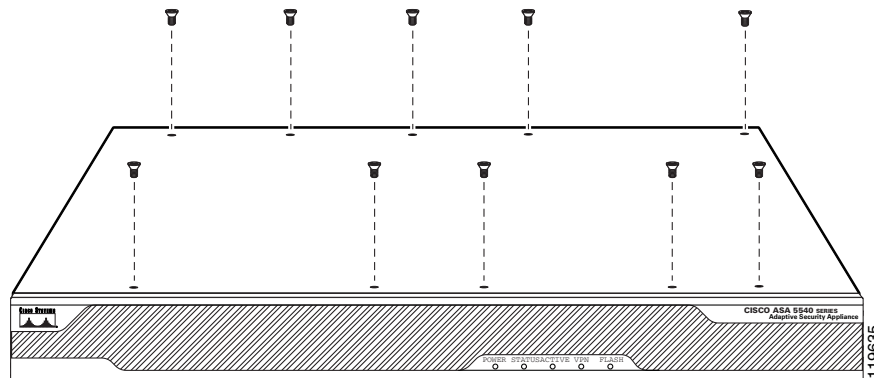

- Step 5** Reinstall the chassis on a rack.
- Step 6** Reinstall the network interface cables.

Working in an ESD Environment

Electrostatic discharge (ESD) can damage equipment and impair electrical circuitry. ESD damage occurs when electronic components are improperly handled and can result in complete or intermittent failures. Always follow ESD-prevention procedures when you remove and replace components. Ensure that the chassis is electrically connected to earth ground. Wear an ESD-preventive wrist strap, ensuring that it makes good skin contact. Connect the grounding clip to an unpainted surface of the chassis frame to safely ground unwanted ESD voltages. To guard against ESD damage and shocks, the wrist strap and cord must operate properly. If no wrist strap is available, ground yourself by touching the metal part of the chassis.

Removing and Replacing a Lithium Battery in the SSM

To remove and replace the battery in the SSM, perform the following steps:

-
- Step 1** Remove the two screws at the left rear end of the chassis, and remove the slot cover as described in [“Installing and Replacing the Intelligent SSM” section on page 1-20](#).
 - Step 2** Slide the metal clip back and pull the battery out.
 - Step 3** Place the used battery aside.
 - Step 4** Replace the battery with a compactible Lithium CR-2032 battery (which is available at your local electronics or drug store), by sliding the metal clip back and sliding the battery into place.
 - Step 5** Replace the chassis cover as described in the [“Installing and Replacing the Intelligent SSM” section on page 1-20](#).
-

Removing and Replacing the Power Supply

For information on power supply considerations including environmental operating ranges and power requirements, see the following document:

http://www.cisco.com/c/en/us/products/collateral/security/asa-5500-series-next-generation-firewalls/product_data_sheet0900aecd802930c5.html

For information on AC-input power cord options, see [Table 1-1](#) in the [“Power Supply Considerations” section on page 1-4](#)

This section describes how to remove and replace the power supply, and includes the following topics:

- [Removing the AC Power Supply, page 1-4](#)
- [Replacing the AC Power Supply, page 1-6](#)

Removing the AC Power Supply

To remove the AC power supply, perform the following steps:

-
- Step 1** Power off the adaptive security appliance.
 - Step 2** Remove the power cord and all other cables from the chassis.
 - Step 3** Remove the chassis from the rack if it is rack-mounted.
 - Step 4** Remove the chassis cover. See the [“Installing and Replacing the Intelligent SSM” section on page 1-20](#) for more information.
 - Step 5** Place the chassis in an ESD-controlled environment. See the [“Working in an ESD Environment” section on page 1-3](#) for more information.

Step 6 Lift the rear of the chassis from the surface and unscrew both the screws that secures the power supply to the chassis, as shown in [Figure 1-5](#).

Figure 1-5 Removing the Power Supply Screws

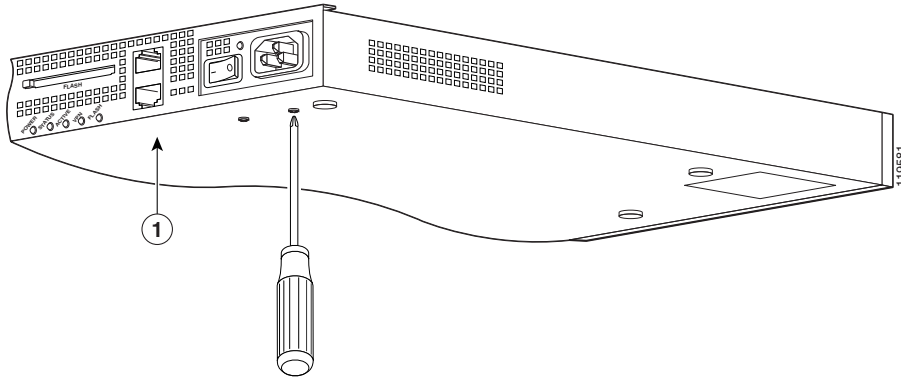

1	Chassis bottom
----------	----------------

Step 7 Locate the power connector on the system board.

Step 8 Unlatch the plug, then grasp the sides of the power connector and pull upward while rocking the connector from side to side. Disconnect the power connector from the system board as shown in [Figure 1-6](#).

Figure 1-6 Disconnecting the Power Connector

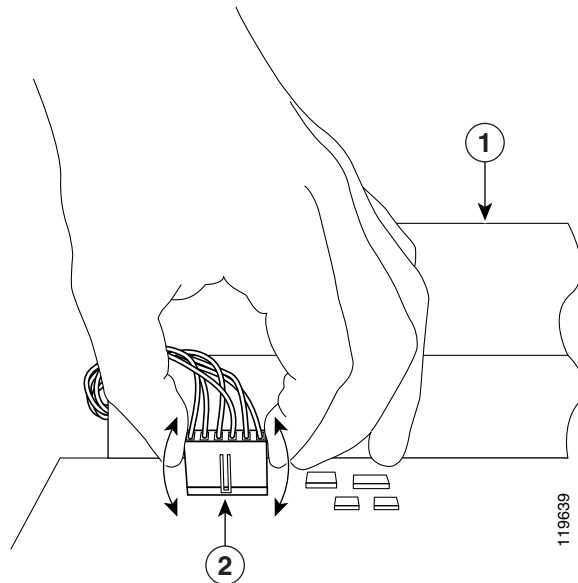

1	AC power supply	2	Power connector
----------	-----------------	----------	-----------------

Step 9 Remove the power supply brace by pulling it up and then out as shown in [Figure 1-7](#).

Figure 1-7 Removing the Power Supply

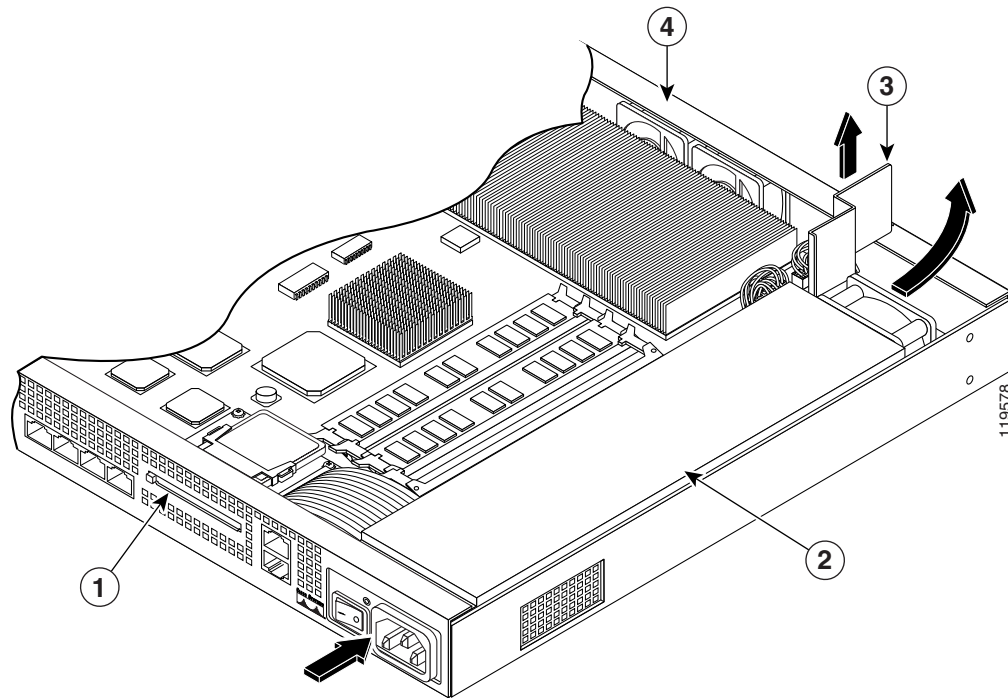

1	Back panel	3	Power supply brace
2	Power supply	4	Front panel

Step 10 From the back of the chassis, push the power supply forward, and then lift it up and out.

Replacing the AC Power Supply

To replace the AC power supply, perform the following steps:

- Step 1** Insert the new power supply into place and slide it towards the back of the adaptive adaptive security appliance.
- Step 2** Lift the rear of the adaptive adaptive security appliance from the surface and reinstall both screws.

Step 3 Insert the power supply brace and press down until it fits into place, as shown in [Figure 1-8](#).

Figure 1-8 Replacing the Power Supply Brace and the AC Power Supply

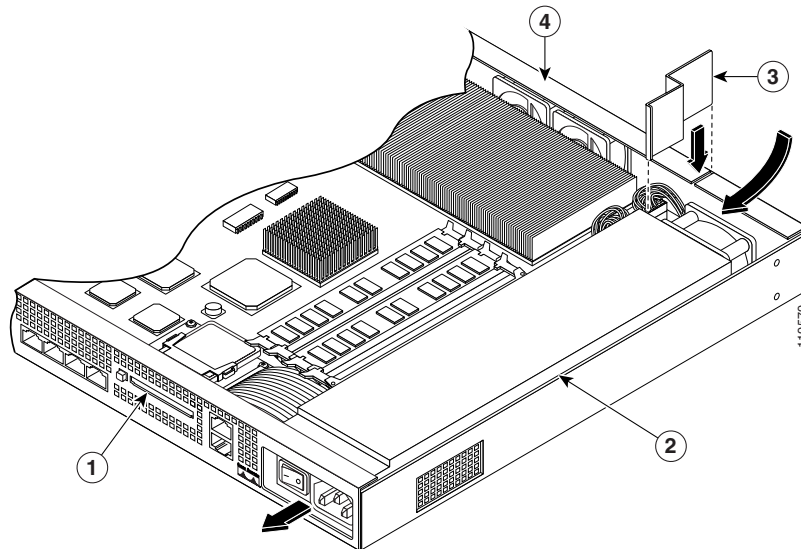

1	Back panel	3	Power supply brace
2	Power supply	4	Front panel

Step 4 Connect the power connector to the system board.

Step 5 Replace the adaptive adaptive security appliance cover. See [“Replacing the Chassis Cover”](#) for more information.

Step 6 Reinstall the network interface cables.

Installing the DC Model



Warning

Before performing any of the following procedures, ensure that power is removed from the DC circuit. To ensure that all power is OFF, locate the circuit breaker on the panel board that services the DC circuit, switch the circuit breaker to the OFF position, and tape the switch handle of the circuit breaker in the OFF position. Statement 7



Note

The DC return connection should remain isolated from the system frame and chassis (DC-I). This equipment is suitable for connection to intra-building wiring only.

To install the DC power model, perform the following steps:

- Step 1** Read the *Regulatory Compliance and Safety Information for the Cisco ASA 5500 Series* document.
- Step 2** Terminate the DC input wiring on a DC source capable of supplying at least 15 amps. A 15-amp circuit breaker is required at the 48 VDC facility power source. An easily accessible disconnect device should be incorporated into the facility wiring.
- Step 3** Locate the DC-input terminal box, see [Figure 1-9](#).

Figure 1-9 DC-Input Terminal Box

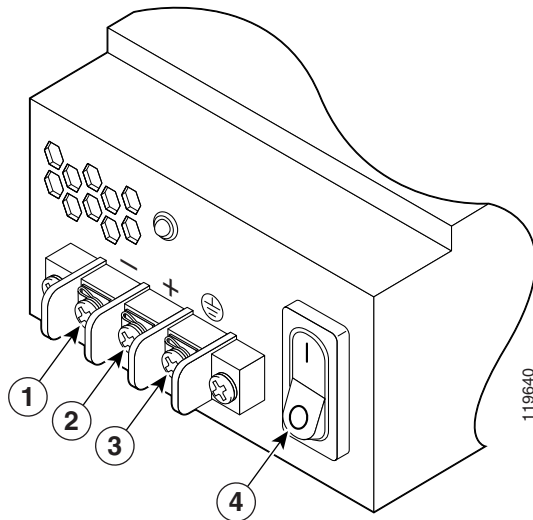

1	Negative	3	Ground
2	Positive	4	On/Off switch

- Step 4** Power off the adaptive security appliance. Ensure that power is removed from the DC circuit. To ensure that all power is OFF, locate the circuit breaker on the panel board that services the DC circuit, switch the circuit breaker to the OFF position, and tape the switch handle of the circuit breaker in the OFF position.
- Step 5** Remove the DC power supply plastic shield.
- Step 6** The adaptive security appliance is equipped with two grounding holes at the side of the chassis, which you can use to connect a two-hole grounding lug to the adaptive security appliance. Use 8-32 screws to connect a copper standard barrel grounding lug to the holes. The adaptive security appliance requires a lug where the distance between the center of each hole is 0.56 inches. A lug is not supplied with the adaptive security appliance.
- Step 7** Strip the ends of the wires for insertion into the power connect lugs on the adaptive security appliance.

- Step 8** Insert the ground wire into the connector for the earth ground and tighten the screw on the connector. See [Figure 1-10](#), and using the same method as for the ground wire, connect the negative wire and then the positive wire.



Note The DC return connection to this system is to remain isolated from the system frame and chassis.

Figure 1-10 DC-Input Power Supply Connections

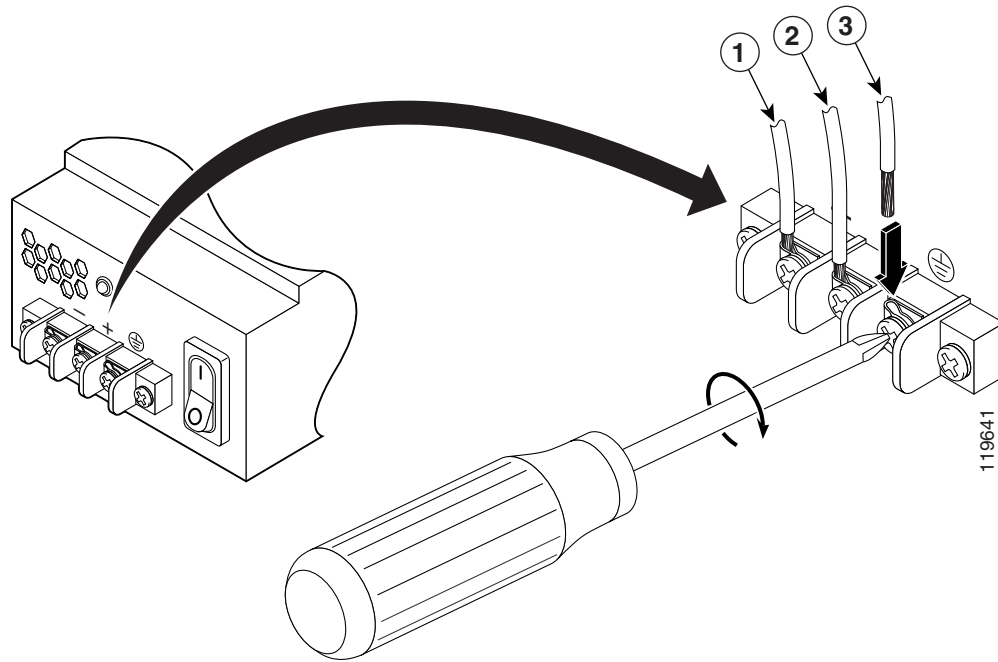

1	Negative	3	Ground
2	Positive		

- Step 9** After wiring the DC power supply, remove the tape from the circuit breaker switch handle and reinstate power by moving the handle of the circuit breaker to the ON position.
- Step 10** Install any remaining interface boards as described in [“Installing the DC Model”](#) section on page 1-7.
- Step 11** Replace the DC power supply plastic shield.
- Step 12** Power on the adaptive security appliance from the switch at the rear of the chassis.



Note If you need to power cycle the DC adaptive security appliance, wait at least 5 seconds between powering off the adaptive security appliance and powering it back on.

Removing and Replacing the CompactFlash

The adaptive security appliance has two types of CompactFlash: the system CompactFlash (internal) and the user CompactFlash (external). This section includes the following topics:

- [Removing and Installing the System CompactFlash, page 1-10](#)
- [Removing and Installing the User CompactFlash, page 1-12](#)

Removing and Installing the System CompactFlash

To remove and install the system CompactFlash, perform the following steps:

-
- Step 1** Power off the adaptive security appliance.
- Step 2** Remove the power cord and other cables from the adaptive security appliance.
- Step 3** Remove the adaptive security appliance from the rack if it is rack-mounted.
- Step 4** Place the adaptive security appliance in an ESD-controlled environment.
- Step 5** Remove the adaptive security appliance cover.
- Step 6** Carefully slide the CompactFlash out of its connector as shown in [Figure 1-11](#). The CompactFlash has a lip on its lower edge, which you can use to grip the CompactFlash. Otherwise, use sliding pressure with your thumb or finger to slide the CompactFlash out of its connector.

Figure 1-11 Removing the System CompactFlash

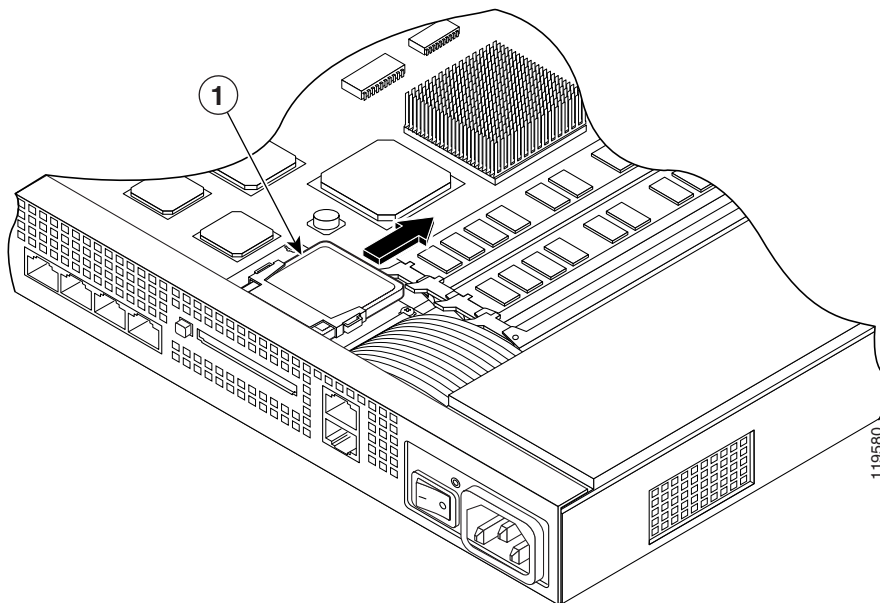

1	System CompactFlash
----------	---------------------

- Step 7** To install the system CompactFlash, align the new system CompactFlash with the connector on the riser card.
- Step 8** Push the system CompactFlash inward until it is fully seated in the connector, see [Figure 1-12](#).

Figure 1-12 Replacing the System CompactFlash

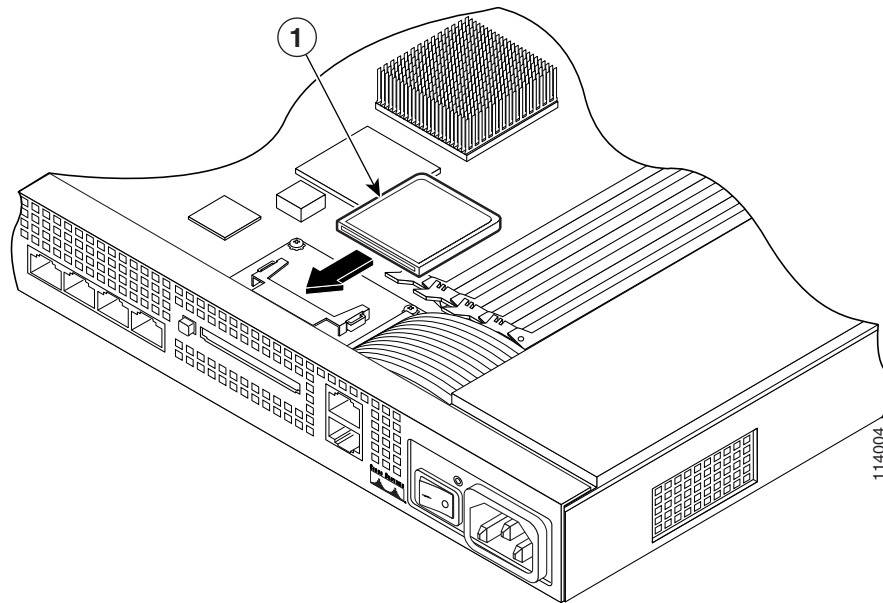

1	System CompactFlash
----------	---------------------

- Step 9** Replace the adaptive security appliance cover.
- Step 10** Reinstall the network interface cables.
-

Removing and Installing the User CompactFlash

To remove and install the user CompactFlash, perform the following steps:



Note

There are two types of CompactFlash release buttons. The release buttons function differently. In this document we refer to them as Type A and Type B.

Step 1 Locate the user CompactFlash in its slot in the rear panel of the chassis. See [Figure 1-13](#).

Figure 1-13 User CompactFlash and Release Button Location—Type A and B

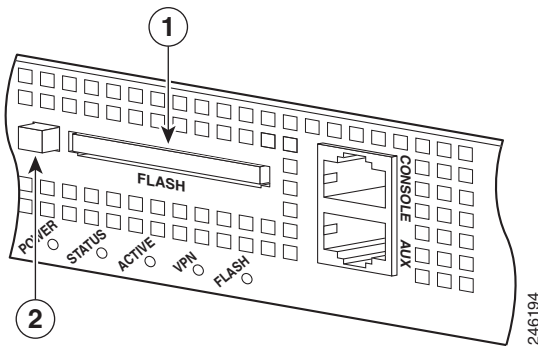

1	User CompactFlash in the slot	2	Release button extended
----------	-------------------------------	----------	-------------------------

Step 2 Press the release button, the release button in Type A will pop out towards you. See [Figure 1-14](#).

In Type B pressing the release button once will eject the CompactFlash, the release button will be slightly extended. See [Figure 1-15](#). If this is the case, skip Step 3 and go to [Step 4](#).

Figure 1-14 Release Button Fully Extended—Type A

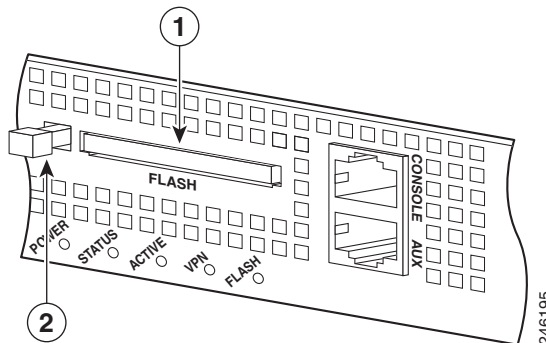

1	User CompactFlash in the slot	2	Release button fully extended
----------	-------------------------------	----------	-------------------------------

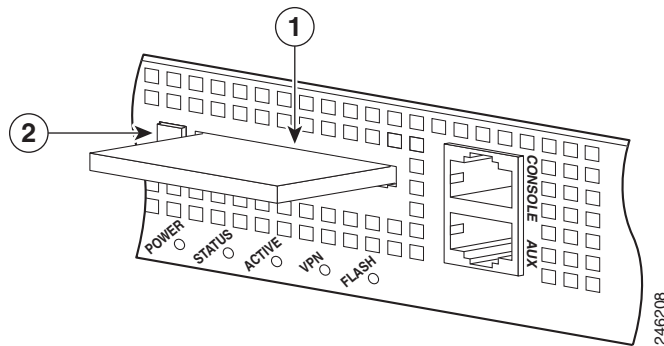
Figure 1-15 User CompactFlash and Release Button Slightly Extended—Type B

1	User CompactFlash	2	Release button slightly extended
---	-------------------	---	----------------------------------

Step 3 Press the release button again, the CompactFlash will eject and the release button will be extended. See [Figure 1-16](#).

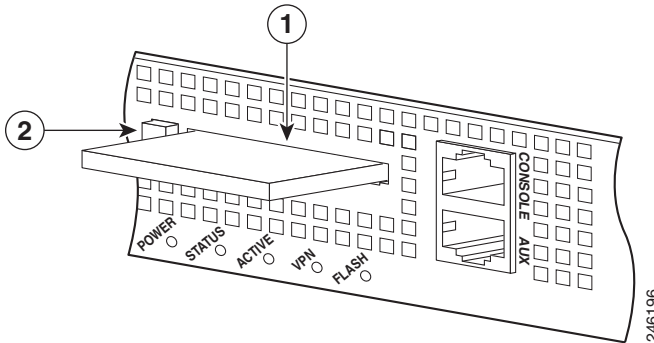
Figure 1-16 User CompactFlash and Release Button Extended—Type A

1	User CompactFlash	2	Release button extended
---	-------------------	---	-------------------------

Step 4 Carefully pull the user CompactFlash out of the slot.



Note When the User CompactFlash slot is empty, the release button on Type A, see [Figure 1-16](#) will be extended and in Type B, see [Figure 1-15](#) the release button will be slightly extended.

Step 5 Place the removed user CompactFlash on an antistatic surface or in a static shielding bag.

Step 6 To install a new CompactFlash, hold the new CompactFlash with the label facing up, insert the connector end of the user CompactFlash into the slot until the card is seated in the connector. The user CompactFlash is keyed so it cannot be inserted the wrong way.

The release button will remain extended when you insert the CompactFlash see [Figure 1-13](#).

Installing and Replacing the 4GE SSM

The 4GE SSM has four 10/100/1000 Mbps, copper, RJ-45 ports and four optional 1000 Mbps, Small-Form-Factor Pluggable (SFP) fiber ports.



Note

When using the 4GE SSM you can use the same numbered copper ports (RJ-45) and the SFP ports at the same time. Use the **media-type** command in interface configuration mode to set the media type to copper or fiber Gigabit Ethernet. For a complete description of the command syntax, see the *Cisco ASA 5500 Series Command Reference*.

This section describes how to install and replace the 4GE SSM in the adaptive security appliance, and includes the following topics:

- [Overview, page 1-14](#)
- [Installing the 4GE SSM, page 1-15](#)
- [Replacing the 4GE SSM, page 1-16](#)
- [Installing and Removing the SFP Modules, page 1-16](#)

Overview

Figure 1-17 lists the 4GE SSM ports and LEDs.

Figure 1-17 4GE SSM Ports and LEDs

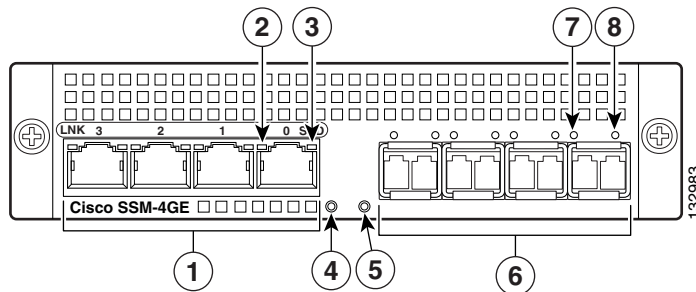

1	RJ-45 ports	5	Status LED
2	RJ-45 Link LED	6	SFP ports
3	RJ-45 Speed LED	7	SFP Link LED
4	Power LED	8	SFP Speed LED



Note

Figure 1-17 shows SFP modules installed in the ports slots. You must order and install the SFP modules if you want to use this feature. For more information on SFP ports and modules, see the “[Installing and Removing the SFP Modules](#)” section on page 1-16.

Table 1-1 describes the 4GE SSM LEDs.

Table 1-1 4GE SSM LEDs

	LED	Color	State	Description
2, 7	LINK	Green	Solid	There is an Ethernet link.
			Flashing	There is Ethernet activity.
3, 8	SPEED	Off	10 MB	There is no network activity.
		Green	100 MB	There is network activity at 100 Mbps.
		Amber	1000 MB (GigE)	There is network activity at 1000 Mbps.
4	POWER	Green	On	The system has power.
5	STATUS	Green	Flashing	The system is booting.
		Green	Solid	The system booted correctly.
		Amber	Solid	The system diagnostics failed.

Installing the 4GE SSM

To install a new 4GE SSM for the first time, perform the following steps:

-
- Step 1** Power off the adaptive security appliance.
 - Step 2** Locate the grounding strap from the accessory kit and fasten it to your wrist so that it contacts your bare skin. Attach the other end to the chassis.
 - Step 3** Remove the two screws (as shown in [Figure 1-18](#)) at the left rear end of the chassis, and remove the slot cover.

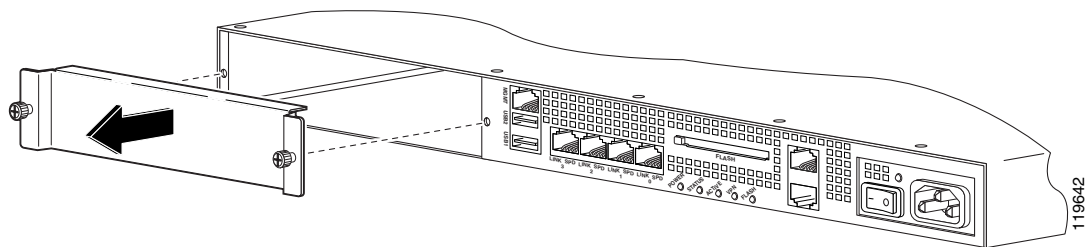
Figure 1-18 Removing the Screws from the Slot Cover

- Step 4** Insert the 4GE SSM through the slot opening as shown in [Figure 1-19](#).

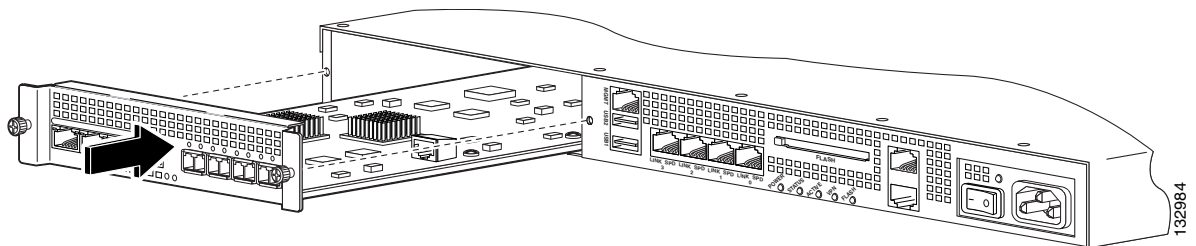
Figure 1-19 Inserting the 4GE SSM into the Slot

- Step 5** Attach the screws to secure the 4GE SSM to the chassis.
 - Step 6** Power on the adaptive security appliance.
 - Step 7** Check the LEDs. If the 4GE SSM is installed properly the STATUS LED flashes during boot up and is solid when operational.
 - Step 8** Connect one end of the RJ-45 cable to the port and the other end of the cable to your network devices.
-

Replacing the 4GE SSM

To replace an existing 4GE SSM, perform the following steps:

- Step 1** Power off the adaptive security appliance.
 - Step 2** Locate the grounding strap from the accessory kit and fasten it to your wrist, so that it contacts your bare skin. Attach the other end to the chassis.
 - Step 3** Remove the two screws at the left rear end of the chassis.
 - Step 4** Remove the 4GE SSM. Place it in a static bag and set it aside.
 - Step 5** Replace the existing card by inserting the new 4GE SSM through the slot opening.
 - Step 6** Attach the screws to secure the 4GE SSM to the chassis.
 - Step 7** Power on the adaptive security appliance.
 - Step 8** Check the LEDs. If the 4GE SSM is installed properly, the POWER LED is solid green and the STATUS LED is flashing during boot up.
 - Step 9** Connect the RJ-45 cable to the port and the other end of the cable to your network devices.
-

Installing and Removing the SFP Modules

The SFP is a hot-swappable input/output device that plugs into the SFP ports. The following SFP module types are supported:

- Long wavelength/long haul 1000BASE-LX/LH (GLC-LH-SM=)
- Short wavelength 1000BASE-SX (GLC-SX-MM=)

This section describes how to install and remove the SFP modules in the adaptive security appliance to provide optical Gigabit Ethernet connectivity. It contains the following topics:

- [SFP Module, page 1-16](#)
- [Installing the SFP Module, page 1-18](#)
- [Removing the SFP Module, page 1-19](#)

SFP Module

The adaptive security appliance uses a field-replaceable SFP module to establish Gigabit connections.

[Table 1-2](#) lists the SFP modules that are supported by the adaptive security appliance.

Table 1-2 Supported SFP Modules

SFP Module	Type of Connection	Cisco Part Number
1000BASE-LX/LH	Fiber-optic	GLC-LH-SM=
1000BASE-SX	Fiber-optic	GLC-SX-MM=

The 1000BASE-LX/LH and 1000BASE-SX SFP modules are used to establish fiber-optic connections. Use fiber-optic cables with LC connectors to connect to an SFP module. The SFP modules support 850 to 1550 nm nominal wavelengths. The cables must not exceed the required cable length for reliable communications. [Table 1-3](#) lists the cable length requirements.

Table 1-3 Cabling Requirements for Fiber-Optic SFP Modules

SFP Module	62.5/125 micron Multimode 850 nm Fiber	50/125 micron Multimode 850 nm Fiber	62.5/125 micron Multimode 1310 nm Fiber	50/125 micron Multimode 1310 nm Fiber	9/125 micron Single-mode 1310 nm Fiber
LX/LH	—	—	550 m at 500 Mhz-km	550 m at 400 Mhz-km	10 km
SX	275 m at 200 Mhz-km	550 m at 500 Mhz-km	—	—	—

Use only Cisco certified SFP modules on the adaptive security appliance. Each SFP module has an internal serial EEPROM that is encoded with security information. This encoding provides a way for Cisco to identify and validate that the SFP module meets the requirements for the adaptive security appliance.

**Note**

Only SFP modules certified by Cisco are supported on the adaptive security appliance.

**Caution**

Protect your SFP modules by inserting clean dust plugs into the SFPs after the cables are extracted from them. Be sure to clean the optic surfaces of the fiber cables before you plug them back into the optical bores of another SFP module. Avoid getting dust and other contaminants into the optical bores of your SFP modules. The optics do not work correctly when obstructed with dust.

**Warning**

Because invisible laser radiation may be emitted from the aperture of the port when no cable is connected, avoid exposure to laser radiation and do not stare into open apertures. Statement 70

Installing the SFP Module

To install the SFP module in the 4GE SSM, perform the following steps:

- Step 1** Line up the SFP module with the port and slide the SFP module into the port slot until it locks into position as shown in [Figure 1-20](#).

Figure 1-20 Installing an SFP Module

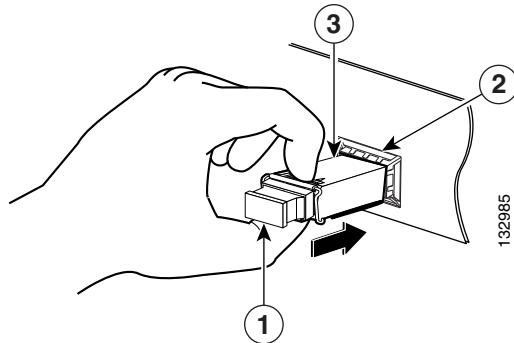

1	Optical port plug	2	SFP port slot
3	SFP module		



Caution

Do not remove the optical port plugs from the SFP until you are ready to connect cabling.

- Step 2** Remove the Optical port plug; then connect the network cable to the SFP module.
- Step 3** Connect the other end of the cable to your network.



Caution

The latching mechanism used on many SFPs locks them into place when cables are connected. Do not pull on the cabling in an attempt to remove the SFP.

Removing the SFP Module

The SFP modules have different types of latching devices used to detach the SFP module from a port. The following are the different types of modules:

- Mylar Tab Module
- Actuator/Button SFP Module
- Bale-Clasp SFP Module
- Plastic Collar Module

To remove the SFP module, perform the following steps:

Step 1 Disconnect all cables from the SFP.



Warning

Because invisible laser radiation may be emitted from the aperture of the port when no cable is connected, avoid exposure to laser radiation and do not stare into open apertures. Statement 70



Caution

The latching mechanism used on many SFPs locks the SFP into place when cables are connected. Do not pull on the cabling in an attempt to remove the SFP.

Step 2 Disconnect the SFP latch as shown in [Figure 1-21](#).



Note

SFP modules use various latch designs to secure the module in the SFP port. Latch designs are not linked to SFP model or technology type. For information on the SFP technology type and model, see the label on the side of the SFP.

Figure 1-21 Disconnecting SFP Latch Mechanisms

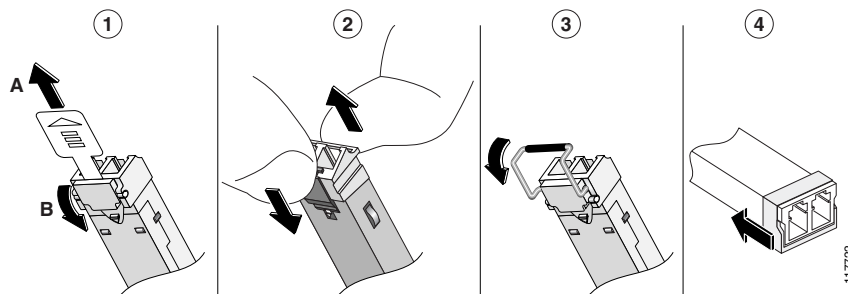

1	Mylar tab	2	Actuator/Button
3	Bale-clasp	4	Plastic collar

Step 3 Grasp the SFP on both sides and remove it from the port.

Installing and Replacing the Intelligent SSM

The Cisco ASA 5510, Cisco ASA 5520, Cisco ASA 5540 support the AIP SSM and the CSC SSM, also referred to as the intelligent SSM in this document. The AIP SSM runs advanced IPS software that provides security inspection. There are three types of AIP SSM: the AIP SSM 10, AIP SSM 20 and the AIP SSM 40. The AIP SSM 10 and the AIP SSM 20 look identical, but the AIP SSM 20 has a faster processor and more memory than the AIP SSM 10. The AIP SSM 40 has a faster processor and more memory than both the AIP SSM 10 and the AIP SSM 20. Only one module (the AIP SSM 10, AIP SSM 20, or the AIP SSM 40) can populate the slot at a time.

[Table 1-4](#) lists the memory specifications for the AIP SSM 10, AIP SSM 20, and the AIP SSM 40.

Table 1-4 AIP/CSC SSM Memory Specifications

SSM	CPU	DRAM
AIP SSM 10	2.0 GHz Celeron	1.0 GB
AIP SSM 20	2.4 GHz Pentium 4	2.0 GB
AIP SSM 40	2.0 GHz Xeon LV	4.0 GB

For more information on the AIP SSM 10/20/40, see the “[Managing the AIP SSM](#)” section in the *Cisco Security Appliance Command Line Configuration Guide*.

The CSC SSM runs Content Security and Control software. The CSC SSM provides protection against viruses, spyware, spam, and other unwanted traffic. There are two types of CSC SSM: the CSC SSM 10, and the CSC SSM 20. For more information on the CSC SSM 10/20, see the “[Managing the CSC SSM](#)” section in the *Cisco Security Appliance Command Line Configuration Guide*.

[Table 1-5](#) shows the AIP/CSC SSMs supported by each platform:

Table 1-5 SSM Support

Platform	SSM Models
Cisco ASA 5510	AIP SSM 10 CSC SSM 10 CSC SSM 20 4GE SSM
Cisco ASA 5520	AIP SSM 10 AIP SSM 20 AIP SSM 40 CSC SSM 10 CSC SSM 20 4GE SSM
Cisco ASA 5540	AIP SSM 10 AIP SSM 20 AIP SSM 40 4GE SSM

This section describes how to install and replace the AIP/CSC SSM in the adaptive security appliance, and includes the following topics:

- [Overview, page 1-21](#)
- [Installing and Replacing the AIP/CSC SSM, page 1-22](#)

Overview

Figure 1-22 lists the AIP/CSC SSM 10/20 LEDs.

Figure 1-22 AIP/CSC SSM 10/20 LEDs

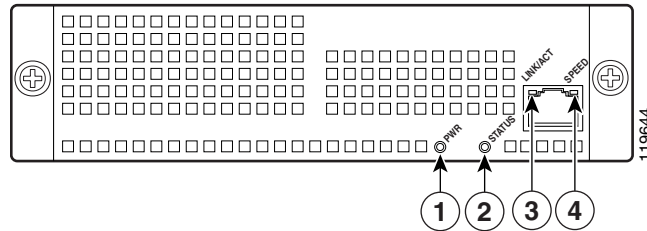

Table 1-6 describes the AIP/CSC SSM 10/20 LEDs.

Table 1-6 AIP/CSC SSM 10/20 LEDs

	LED	Color	State	Description
1	PWR	Green	On	The system has power.
2	STATUS	Green	Flashing	The system is booting.
			Solid	The system has passed power-up diagnostics.
3	LINK/ACT	Green	Solid	There is an Ethernet link.
			Flashing	There is Ethernet activity.
4	SPEED	Off	10 MB	Indicates a 10MB connection.
		Green	100 MB	Indicates a 100MB connection.
		Amber	1000 MB (GigE)	Indicates a 1000MB connection.

Figure 1-23 lists the AIP/CSC SSM 40 LEDs.

Figure 1-23 AIP/CSC SSM 40 LEDs

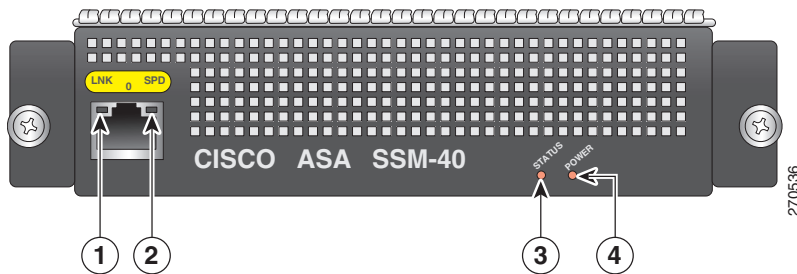

Table 1-6 describes the AIP/CSC SSM 10/20 LEDs.

Table 1-7 AIP/CSC SSM 40 LEDs

	LED	Color	State	Description
1	LNK	Green	Solid Flashing	There is an Ethernet link. There is Ethernet activity.
2	SPEED	Off Green Amber	10 MB 100 MB 1000 MB (GigE)	Indicates a 10MB connection. Indicates a 100MB connection. Indicates a 1000MB connection.
3	STATUS	Green	Solid Flashing	The system is booting. The system has passed power-up diagnostics.
4	POWER	Green	On	The system has power.

Installing and Replacing the AIP/CSC SSM

This section describes how to install and replace the AIP/CSC SSM in the adaptive security appliance. The section includes the following topics:

- [Installing the AIP/CSC SSM, page 1-22](#)
- [Replacing the AIP/CSC SSM, page 1-23](#)

Installing the AIP/CSC SSM

To install a new AIP/CSC SSM for the first time, perform the following steps:

-
- Step 1** Enter the `hw-mod mod 1 shut` command in privileged EXEC mode. Verify that the module is down by making sure that the LEDs are all off.
- Step 2** Locate the grounding strap from the accessory kit and fasten it to your wrist so that it contacts your bare skin. Attach the other end to the chassis.
- Step 3** Remove the two screws at the left rear end of the chassis, and remove the slot cover as shown in [Figure 1-24](#).

Figure 1-24 Removing the Screws from the Slot Cover

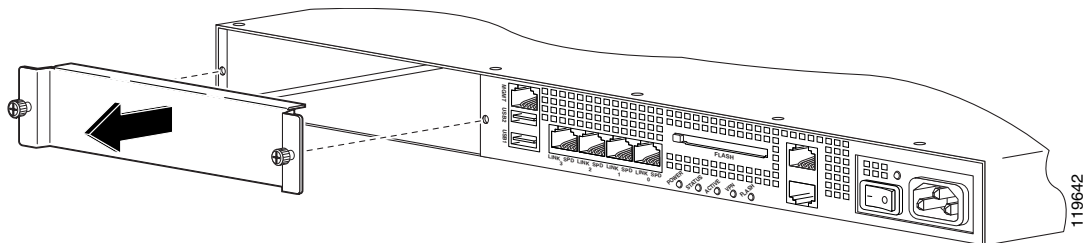

- Step 4** Insert the AIP/CSC SSM in to the slot opening as shown in [Figure 1-25](#).

Figure 1-25 Inserting the AIP/CSC SSM into the Slot

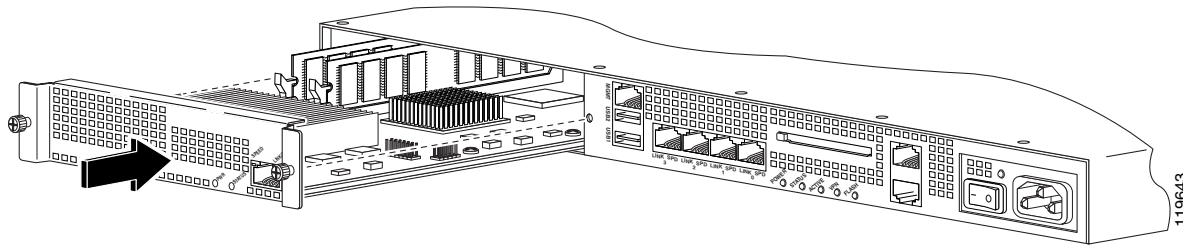

- Step 5** Attach the screws to secure the AIP/CSC SSM to the chassis.
- Step 6** Enter the **hw-mod mod 1 reset** command in privileged EXEC mode to reset the AIP/CSC SSM.
- Step 7** Check the LEDs. If the AIP/CSC SSM is installed properly, the POWER LED is solid green and the STATUS LED flashes green.

Replacing the AIP/CSC SSM

To replace an existing AIP/CSC SSM, perform the following steps:

- Step 1** Enter the **hw-mod mod 1 shut** command in privileged EXEC mode. Verify that the module is down by making sure that the LEDs are all off.
- Step 2** Locate the grounding strap from the accessory kit and fasten it to your wrist, so that it contacts your bare skin. Attach the other end to the chassis.
- Step 3** Remove the two screws at the left rear end of the chassis.
- Step 4** Remove the AIP/CSC SSM. Place it in a static bag and set it aside.
- Step 5** Replace the existing card by inserting the new AIP/CSC SSM through the slot opening.
- Step 6** Attach the screws to secure the AIP/CSC SSM to the chassis.
- Step 7** Enter the **hw-mod mod 1 reset** command in privileged EXEC mode to reset the AIP/CSC SSM.
- Step 8** Check the LEDs. If the AIP/CSC SSM is installed properly, the POWER LED is solid green and the STATUS LED flashes green.

Replacing Memory in the Adaptive Security Appliance

This section describes how to change DRAM (also referred to as DIMM) in the adaptive security appliance. The section includes the following topics:

- [Overview, page 1-24](#)
- [Removing and Installing the DIMM, page 1-25](#)

Overview

Cisco ASA 5510

The memory kit, ASA5510-MEM-512=, lets you change or add to the memory in your Cisco ASA 5510.

To determine how much memory your adaptive security appliance has, use the **show version** command; the example below is for the Cisco ASA 5510 chassis:

```
hostname# show version

Cisco Adaptive Security Appliance Software Version 8.0(4)
Device Manager Version 6.1(5)

Compiled on Thu 07-Aug-08 20:53 by builders
System image file is "disk0:/asa804-k8.bin"
Config file at boot was "startup-config"

ciscoasa up 2 days 10 hours
failover cluster up 2 days 11 hours

Hardware: ASA5510, 256 MB RAM, CPU Pentium 4 Celeron 1600 MHz
BIOS Flash AT49LW080 @ 0xffe00000, 1024KB
```

Table 1-8 lists the memory for the Cisco ASA 5510.

Table 1-8 Memory Change

Model	Current Memory	Change to
Cisco ASA 5510	256 MB	512 MB

Cisco ASA 5520/5540/5550

All ASA-5520s and ASA-5540s manufactured before August 2011 have 4 DIMM sockets; all ASA-5520s and ASA-5540s manufactured after this date have 2 DIMM sockets. However, all ASA-5520s and ASA-5540s support only two installed DIMMs.

The ASA-5550 has 4 DIMM sockets, all of which are supported.

The memory kit, ASA5520-MEM-2GB=, lets you change the memory installed in a Cisco ASA 5520. The memory kit, ASA5540-MEM-2GB=, lets you change the memory installed in a Cisco ASA 5540. Two of the ASA5540-MEM-2GB= memory kits also can be used to change the memory in a Cisco ASA 5550.

To determine how much memory your adaptive security appliance currently has, use the **show version** command; the example below is for the Cisco ASA 5520 chassis:

```
hostname# show version

Cisco Adaptive Security Appliance Software Version 8.0(0)
Device Manager Version 6.0(0)

Compiled on Mon 16-April-07 03:29 by root
System image file is "disk0:/cdisk.bin"
Config file at boot was "disk0:/main_backup.cfg"

hostname up 2 days 10 hours
failover cluster up 2 days 11 hours

Hardware: ASA5520, 512 MB RAM, CPU Pentium 4 Celeron 2000 MHz
BIOS Flash M50FW016 @ 0xffe00000, 2048KB
```

Table 1-8 lists the memory for the Cisco ASA 5520, Cisco ASA 5540 and Cisco ASA 5550.

Table 9 Memory Changes

Model	Current Memory	Change to
Cisco ASA 5520	512 MB	2 GB
Cisco ASA 5540	1 GB	2 GB
Cisco ASA 5550	4 GB	4 GB

Removing and Installing the DIMM

This section describes how to remove and install dual in-line memory modules (DIMMs) on the adaptive security appliance. This section includes the following topics:

- [Removing the DIMM, page 1-25](#)
- [Installing the DIMM, page 1-28](#)

Removing the DIMM

To remove a memory module, perform the following steps:

-
- Step 1** Turn off power to the adaptive security appliance.
 - Step 2** Remove the power cord and other cables from the adaptive security appliance.
 - Step 3** Remove the adaptive security appliance from the rack if it is rack-mounted.
 - Step 4** Place the adaptive security appliance in an ESD-controlled environment. See the [“Working in an ESD Environment” section on page 1-3](#) for more information.
 - Step 5** Remove the adaptive security appliance cover. See the [“Removing and Replacing the Chassis Cover” section on page 1-1](#) for the procedure.
 - Step 6** Determine the location of the memory sockets. See [Figure 1-26](#) for the Cisco ASA 5510 and [Figure 1-27](#) for the Cisco ASA 5520, Cisco ASA 5540, or Cisco ASA 5550.



Note Some Cisco ASA 5510 have only a single memory socket, see [Figure 1-26](#). while others have four memory sockets. In both cases, remove the existing DIMM, and replace it with the new one. For memory upgrade in the Cisco ASA 5510 with four memory sockets, use slot 1 - P13 and note that only one slot must be populated at all times.

Figure 1-26 System Memory Location in the Cisco ASA 5510

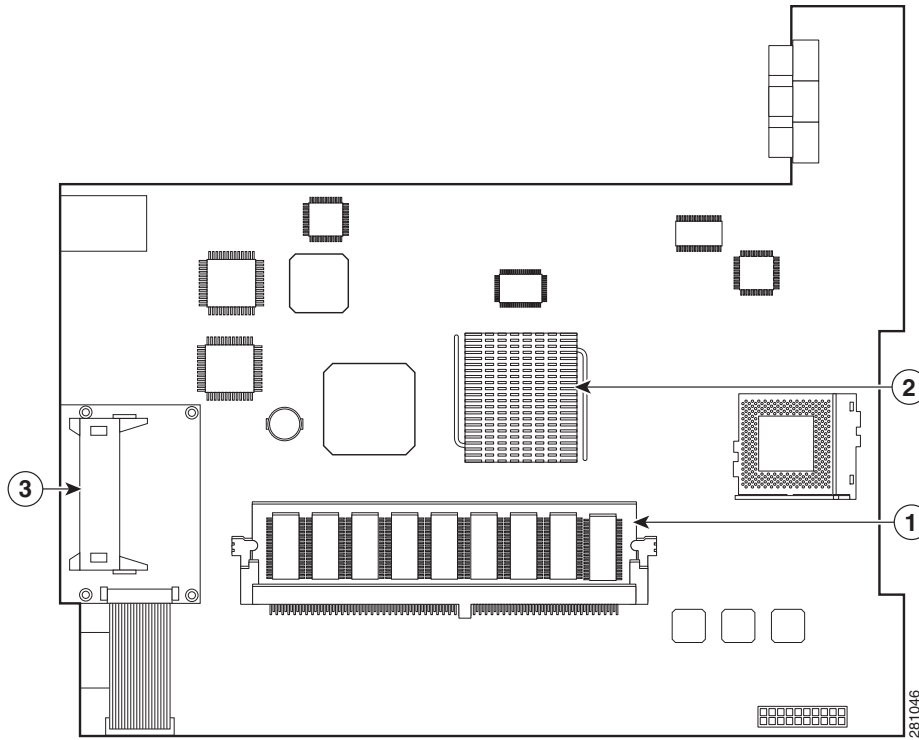

1	DIMM
2	Memory Controller Hub (MCH)
3	CompactFlash socket

Figure 1-27 System Memory Location in the Cisco ASA 5520, Cisco ASA 5540 and the Cisco ASA 5550

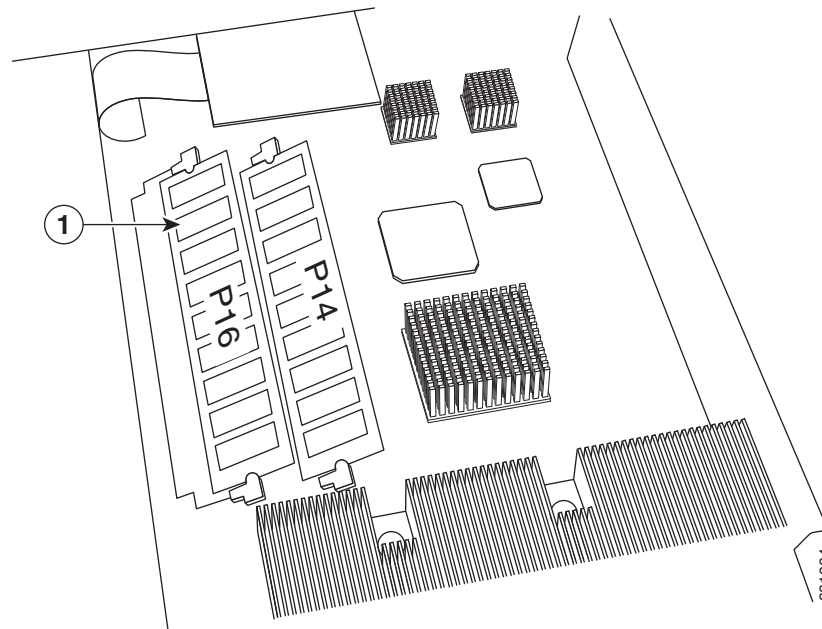

1	DIMM
----------	------



Note All ASA-5520s and ASA-5540s manufactured before August 2011 have 4 DIMM sockets; all ASA-5520s and ASA-5540s manufactured after this date have 2 DIMM sockets. Only two of the sockets on the ASA-5520s and ASA-5540s can be populated. All ASA-5550s have 4 DIMM sockets.

Step 7 Locate the wrist grounding strap and connect one end to the adaptive security appliance, and securely attach the other end to your wrist so it contacts your bare skin. See, [“Working in an ESD Environment” section on page 1-3](#) for more information.



Note Handle the edges of the DIMM only; avoid touching the memory modules, pins, or traces (the metal fingers along the connector edge of the DIMM), along the connector edge.

To prevent ESD damage, handle DIMMs as shown in [Figure 1-28](#).

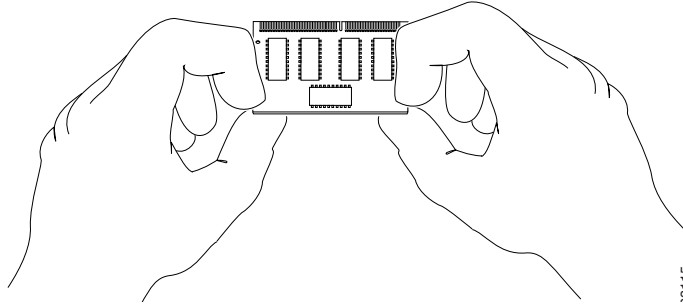
Figure 1-28 Handling a DIMM

- Step 8** Pull the latches away from the DIMM at both ends and release the DIMM from the socket. See [Figure 1-29](#).
- Step 9** When both ends of the DIMM are released from the socket, grasp the ends of the DIMM with your thumb and forefinger and pull the DIMM completely out of the socket.
- Step 10** Place the DIMM in an antistatic container to protect it from ESD damage.

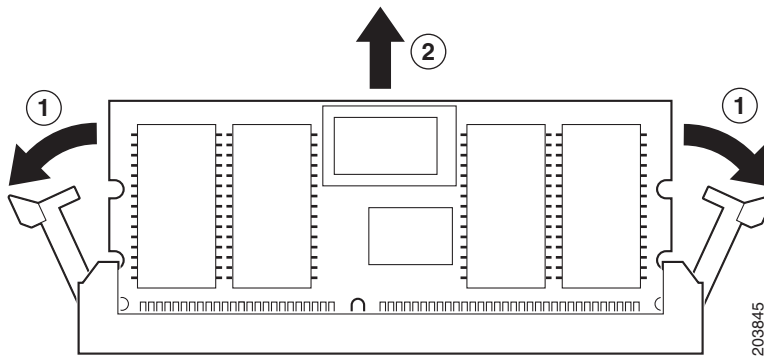
Figure 1-29 Releasing the DIMM Latches

Installing the DIMM

To install a memory module, perform the following steps:

- Step 1** Make sure that both latches on the DIMM connector are open.
- Step 2** Remove a new DIMM from the antistatic container.
- The DIMM is designed in such a way that the connector will fit only one way.
- Step 3** Hold the DIMM component side up, with the connector edge away from you. Line up the notch in the connector traces with the notch in the socket on the board.
- Step 4** Carefully insert the connector edge into the socket and firmly press the DIMM into the socket until both latches rotate to the close position against the DIMM.



Note For memory upgrade in the Cisco ASA 5510 with four memory sockets, use slot 1 - P13 and note that only one slot must be populated at all times.

Figure 1-30 Inserting the DIMM

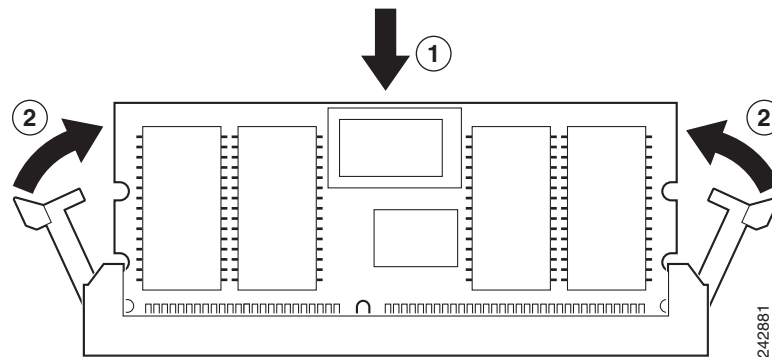
**Caution**

When inserting DIMMs, use pressure, but not excessive pressure as this can cause damage to the socket.

- Step 5** When you finish installing the DIMM, replace the adaptive security appliance cover. See the [“Removing and Replacing the Chassis Cover”](#) section on page 1-1 for the procedure.
- Step 6** Reinstall the network interface cables.

Verifying the Memory Upgrade

You can verify that the memory upgrade has been completed successfully by entering the **show version** command. Here is an example from a Cisco ASA 5510 chassis:

```
hostname# show version

Cisco Adaptive Security Appliance Software Version 8.0(4)
Device Manager Version 6.1(5)

Compiled on Thu 07-Aug-08 20:53 by builders
System image file is "disk0:/asa804-k8.bin"
Config file at boot was "startup-config"

ciscoasa up 2 days 10 hours
failover cluster up 2 days 11 hours

Hardware: ASA5510, 1 GB RAM, CPU Pentium 4 Celeron 1600 MHz
BIOS Flash AT49LW080 @ 0xffe00000, 1024KB
```

Here is an example from a Cisco ASA 5520 chassis:

```
hostname# show version

Cisco Adaptive Security Appliance Software Version 8.0(0)
Device Manager Version 6.0(0)

Compiled on Mon 16-April-07 03:29 by root
System image file is "disk0:/cdisk.bin"
Config file at boot was "disk0:/main_backup.cfg"
hostname up 2 days 10 hours
failover cluster up 2 days 11 hours

Hardware: ASA5520, 2 GB RAM, CPU Pentium 4 Celeron 2000 MHz
BIOS Flash M50FW016 @ 0xffe00000, 2048KB
```



Cable Pinouts

This appendix describes pinout information, and includes the following sections:

- [10/100/1000BaseT Ports, page 1-1](#)
- [Console Port \(RJ-45\), page 1-2](#)
- [Console RJ-45 to DB-9 Adapter, page 1-4](#)
- [MGMT 10/100 Fast Ethernet Port, page 1-4](#)
- [SFP Fiber Ports, page 1-5](#)

10/100/1000BaseT Ports

The adaptive security appliance supports 10/100/1000BaseT ports. You must use at least a Category 5 cable for 100/1000baseT operations, but a Category 3 cable can be used for 10BaseT operations.

The 10/100/1000BaseT ports use standard RJ-45 connectors and supports MDI and MDI-X connectors. Ethernet ports normally use MDI connectors and Ethernet ports on a hub normally use an MDI-X connector.

Use an Ethernet straight-through cable to connect an MDI to an MDI-X port. Use a cross-over cable to connect an MDI to an MDI port, or an MDI-X to an MDI-X port.

[Figure 1-1](#) shows the 10BaseT and the 100BaseTX connector (RJ-45).

Figure 1-1 10/100 Port Pinouts

Pin	Label	1 2 3 4 5 6 7 8
1	RD+	
2	RD-	
3	TD+	
4	NC	
5	NC	
6	TD-	
7	NC	
8	NC	

Figure 1-2 shows the 10BaseT, 100BaseTX, and 1000BASE-T connector (RJ-45).

Figure 1-2 10/100/1000 Port Pinouts

Pin	Label	1	2	3	4	5	6	7	8
1	TP0+								
2	TP0-								
3	TP1+								
4	TP2+								
5	TP2-								
6	TP1-								
7	TP3+								
8	TP3-								

Console Port (RJ-45)

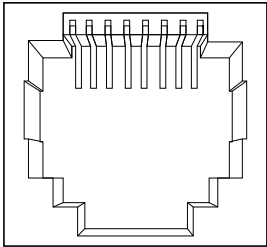
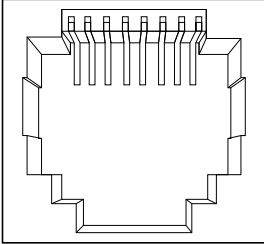
Cisco products use the following types of RJ-45 cables:

- Straight-through
- Crossover



Note

Cisco does not provide these cables; they are widely available from other sources.

Figure 1-3 shows the RJ 45 cable.

Figure 1-3 RJ-45 Cable

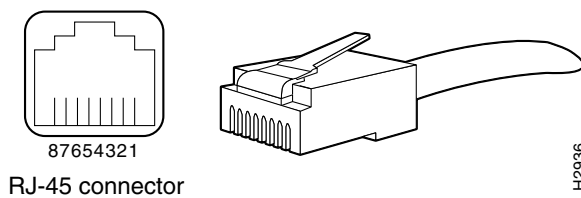

To identify the RJ-45 cable type, hold the two ends of the cable next to each other so that you can see the colored wires inside the ends, as shown in [Figure 1-4](#).

Figure 1-4 *RJ-45 Cable Identification*

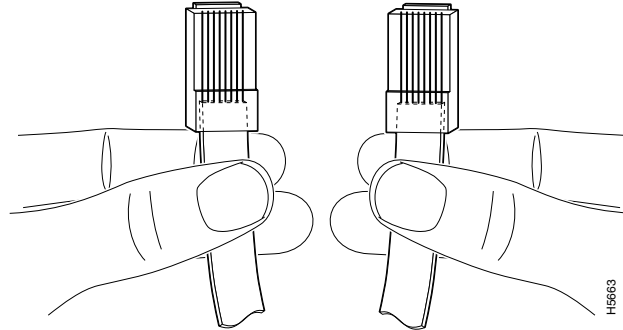

Examine the sequence of colored wires to determine the type of RJ-45 cable, as follows:

- Straight-through—The colored wires are in the same sequence at both ends of the cable.
- Crossover—The first (far left) colored wire at one end of the cable is the third colored wire at the other end of the cable.

[Table 1-1](#) lists the rolled (console) cable pinouts for RJ-45.

Table 1-1 *RJ-45 Rolled (Console) Cable Pinouts*

Signal	Pin	Pin	Pin
-	1	8	-
-	2	7	-
-	3	6	-
-	4	5	-
-	5	4	-
-	6	3	-
-	7	2	-
-	8	1	-

Console RJ-45 to DB-9 Adapter

Table 1-2 lists the cable pinouts for RJ-45 to DB-9 or DB-25.

Table 1-2 Cable Pinouts for RJ-45 to DB-9 or DB-25

Signal	RJ-45 Pin	DB-9 Pin
RTS	8	8
DTR	7	6
TxD	6	2
GND	5	5
GND	4	5
RxD	3	3
DSR	2	4
CTS	1	7

MGMT 10/100 Fast Ethernet Port

The MGMT 10/100 Fast Ethernet port has an RJ-45 connector. You can use a modular, RJ-45, straight-through UTP cable to connect the management port to an external hub, switch, or router.

Table 1-3 lists the cable pinouts for 10/100BASE-T Management Port Cable Pinouts (MDI).

Table 1-3 10/100BASE-T Management Port Cable Pinouts (MDI)

Signal	Pin
TD+	1
TD-	2
RD+	3
RD-	6
Not used	4
Not used	5
Not used	7
Not used	8

SFP Fiber Ports

Table 1-4 lists the types of SFP modules and connectors used in the adaptive security appliance.

Table 1-4 *Types of SFP Modules and Connectors*

Port	Compliance	Connector	Fiber Type
Gigabit Ethernet	1000BASE-SX	SW	MMF
	1000BASE-LX	LW	SMF

Table 1-5 lists the SFP port cabling specifications for the SFP modules and connectors used in the adaptive security appliance.

Table 1-5 *SFP Port Cabling Specifications*

Cisco Product Number	Wavelength (nanometer)	Core Size (micron)	Baud Rate	Cable Distance
GLC-SX-MM=	850	62.5	1.0625	300 m
		50.0	1.0625	500 m
GLC-LH-SM=	1300	9.0	1.0625	10 km



INDEX

Numerics

- 1000 W power supplies
 - power cords (table) [2-5](#)
- 4GE SSM [4-15, 4-22](#)

A

- AC-input power cords
 - product numbers (table) [2-5](#)
- ASA
 - replacing lithium battery [4-4](#)
- AUX port [1-2](#)

C

- chassis covers
 - removing [4-1](#)
 - replacing [4-2](#)
- circuit breaker for DC unit [2-3](#)
- Cisco warranty [2-2](#)
- CompactFlash
 - External [1-2, 1-3](#)
 - Internal [4-10, 4-12](#)
- Console port [3-6](#)
- CPU [1-5](#)

E

- electrostatic discharge
 - see ESD
- equipment racks
 - tips [2-7](#)

ESD

- preventing [2-3, 4-3](#)

F

- failover [1-5, 3-4](#)
- fans
 - ventilation [2-7](#)

G

- grounding lug
 - attaching [4-8](#)

I

- interface cables [3-4](#)
 - 4GE SSM [3-7](#)
 - console port [3-6](#)
 - management port [3-5](#)
 - SSM [3-9](#)

L

- LC connector [3-8](#)
- LEDs [1-4, 4-14, 4-21](#)

M

- memory requirements [1-5](#)
- MGMT [1-2, 1-3, 3-5](#)

N

Network interfaces [1-2](#)

P

panel

removing [4-2](#)

power LEDs [1-3, 1-4, 4-14, 4-21](#)

power supplies

considerations [2-4](#)

product overview [1-2](#)

R

rear panels (figure) [1-4](#)

RJ-45 connector

pinouts [1-4](#)

RJ-45 port [3-7](#)

rubber feet

attaching [3-3](#)

S

safety [2-2](#)

Serial Console port [1-2, 1-3](#)

SFP [3-7, 4-16](#)

site environment [2-4](#)

SSM [3-9, 4-4](#)

4GE SSM

connecting [3-7](#)

installing [4-15, 4-22](#)

LEDs [1-3, 4-14](#)

replacing [4-16, 4-23](#)

V

ventilation fans [2-7](#)

W

warranty [2-2](#)