

# SHOP MANUAL

# MASSEY-FERGUSON

## MODELS

MF230-MF235-MF240-MF245-MF250

Tractor serial number is stamped on a name plate attached to the side of instrument console. Diesel engine serial number is stamped on right side of cylinder block near the fuel lift pump. Gasoline engine serial number is stamped on a plate attached to left side of cylinder block above the distributor.

## INDEX (By Starting Paragraph)

<p><b>BRAKES</b></p> <p>Disc Type .....173</p> <p>Shoe Type .....171</p> <p><b>CLUTCH (Engine)</b></p> <p>Adjustment .....110</p> <p>Dual Clutch .....113</p> <p>Split Torque Clutch.....116</p> <p>Tractor Split.....112</p> <p><b>DIFFERENTIAL</b></p> <p>Bevel Drive Gears .....163</p> <p>Differential Lock .....160</p> <p>R&amp;R and Overhaul .....158</p> <p><b>ELECTRICAL SYSTEM</b></p> <p>Alternator &amp; Regulator .....101</p> <p>Starting Motor .....107</p> <p>Wiring Diagrams .....239</p> <p><b>ENGINE (Diesel)</b></p> <p>Assembly, R&amp;R .....56</p> <p>Camshaft .....71</p> <p>Connecting Rods &amp; Bearings .....75</p> <p>Cooling System .....82</p> <p>Crankshaft &amp; Bearings.....76</p> <p>Cylinder Head .....57</p> <p>Oil Pump .....81</p> <p>Pistons, Sleeves &amp; Rings .....73</p> <p>Timing Gears .....65</p>	<p><b>ENGINE (Gasoline)</b></p> <p>Assembly, R&amp;R .....25</p> <p>Camshaft .....36</p> <p>Connecting Rods &amp; Bearings ...40</p> <p>Cooling System .....50</p> <p>Crankshaft &amp; Bearings.....41</p> <p>Cylinder Head .....26</p> <p>Governor .....48</p> <p>Ignition .....53</p> <p>Oil Pump .....44</p> <p>Pistons, Sleeves &amp; Rings .....38</p> <p>Timing Gears .....35</p> <p><b>FRONT AXLE</b>.....1</p> <p><b>FUEL SYSTEM (Diesel)</b></p> <p>Bleeding .....86</p> <p>Filters .....85</p> <p>Injector Nozzles .....89</p> <p>Injector Pump .....97</p> <p>Timing .....98</p> <p><b>FUEL SYSTEM (Gasoline)</b></p> <p>Carburetor .....46</p> <p><b>HYDRAULIC SYSTEM</b></p> <p>Adjustments .....194</p> <p>Auxiliary Pump .....232</p> <p>Auxiliary Valve .....235</p> <p>General .....184</p>	<p><b>HYDRAULIC SYSTEM Cont.</b></p> <p>Lift Cover .....207</p> <p>Main Hydraulic Pump .....223</p> <p>Reservoir &amp; Filter .....185</p> <p>System Checks .....187</p> <p>Trouble-Shooting .....186</p> <p><b>POWER TAKE-OFF (Independent)</b></p> <p>Clutch Unit .....180</p> <p>Operation .....178</p> <p>Output Shaft .....179</p> <p><b>POWER TAKE-OFF (Live)</b></p> <p>Ground Speed Gears .....176</p> <p>Output Shaft .....175</p> <p><b>REAR AXLE</b></p> <p>With Planetary Final Drive ...167</p> <p>Without Planetary Final Drive .165</p> <p><b>STEERING SYSTEM</b></p> <p>Hydrostatic Type .....18</p> <p>Manual Type .....3</p> <p>Power Assist Type .....6</p> <p><b>TRANSMISSION</b></p> <p>Eight Speed .....127</p> <p>Manual Shuttle .....136</p> <p>Multi-Power .....145</p> <p>Six Speed .....119</p>
---	--	--

---

## DUAL DIMENSIONS

This service manual provides specifications in both Metric (SI) and U.S. Customary systems of measurement. The first specification is given in the measuring system perceived by us to be the preferred system when servicing a particular component, while the second specification (given in parenthesis) is the converted measurement. For instance, a specification of "0.28 mm (0.011 inch)" would indicate that we feel the preferred measurement is the metric system of measurement and the U.S. Customary equivalent of 0.28 mm is 0.011.

# CONDENSED SERVICE DATA

	MF230		MF235	
	Diesel	Gasoline	Diesel	Gasoline
<b>GENERAL</b>				
Engine Make .....	Perkins	Continental	Perkins	Continental
Engine Model .....	AD3.152	Z-145	AD3.152	Z-145
Number of Cylinders .....	3	4	3	4
Bore .....	91.44 mm (3.6 in.)	85.72 mm (3.375 in.)	91.44 mm (3.6 in.)	85.72 mm (3.375 in.)
Stroke .....	127.0 mm (5.0 in.)	103.2 mm (4.063 in.)	127.0 mm (5.0 in.)	103.2 mm (4.063 in.)
Displacement .....	2.5 L (152 cu. in.)	2.4 L (145 cu. in.)	2.5 L (152 cu. in.)	2.4 L (145 cu. in.)
Cylinder Sleeves .....	Dry	Wet	Dry	Wet
Electrical System .....	12 Volt, Negative Ground			
<b>TUNE-UP</b>				
Firing Order .....	1-2-3	1-3-4-2	1-2-3	1-3-4-2
Valve Clearance, Cold—				
Intake .....	0.30 mm (0.012 in.)	0.33 mm (0.013 in.)	0.30 mm (0.012 in.)	0.33 mm (0.013 in.)
Exhaust .....	0.30 mm (0.012 in.)	0.38 mm (0.015 in.)	0.30 mm (0.012 in.)	0.38 mm (0.015 in.)
Valve Clearance, Hot—				
Intake .....	0.25 mm (0.010 in.)	0.28 mm (0.011 in.)	0.25 mm (0.010 in.)	0.28 mm (0.011 in.)
Exhaust .....	0.25 mm (0.010 in.)	0.33 mm (0.013 in.)	0.25 mm (0.010 in.)	0.33 mm (0.013 in.)
Valve Face Angle—				
Intake .....	35°	30°	45°	30°
Exhaust .....	35°	44°	45°	44°
Valve Seat Angle—				
Intake .....	35°	30°	45°	30°
Exhaust .....	35°	45°	45°	45°
Injection Timing, Static .....	24° BTDC	....	24° BTDC	....
Injector Opening Pressure .....				
New .....	19235 kPa (2790 psi)	....	18755 kPa (2720 psi)	....
Used .....	17720 kPa (2570 psi)	....	17240 kPa (2500 psi)	....
Ignition Timing .....	....	8° BTDC	....	8° BTDC
Ignition Point Gap .....	....	0.45-0.55 mm (0.017-0.022 in.)	....	0.45-0.55 mm (0.017-0.022 in.)
Spark Plug Gap .....	....	0.63 mm (0.025 in.)	....	0.63 mm (0.025 in.)
Governed Speeds, Engine Rpm—				
Low Idle .....	725-775	725-775	725-775	725-775
High Idle .....	2135-2185	2200-2250	2400-2450	2425-2500
Full Load .....	2000	2000	2250	2250
Rated Power At Pto Shaft .....	25.75 kW (34.5 hp)	25.6 kW (34.3 hp)	31.6 kW (42.4 hp)	30.7 kW (41.1 hp)
<b>CAPACITIES</b>				
Cooling System .....	9.9 L (10.5 U.S. qts.)	9.5 L (10 U.S. qts.)	9.9 L (10.5 U.S. qts.)	9.5 L (10 U.S. qts.)
Crankcase* .....	4.7 L _____ (5 U.S. qts.)			
Hydraulic System .....	30.3 L _____ (8 U.S. gals.)			
Power Steering .....	0.95 L _____ (1 U.S. qt.)			
Fuel Tank .....	53 L _____ (14 U.S. gals.)			

\* Add 0.95 L ( 1 U.S. quart) if filter is changed.

SIZES—CLEARANCES	MF230		MF235	
	Diesel	Gasoline	Diesel	Gasoline
<b>Crankshaft Main Journal—</b>				
Diameter .....	69.81-69.82 mm (2.7485-2.7490 in.)	57.13-57.15 mm (2.249-2.250 in.)	69.81-69.82 mm (2.7485-2.7490 in.)	57.13-57.15 mm (2.249-2.250 in.)
Bearing Clearance .....	0.08-0.13 mm (0.003-0.005 in.)	0.013-0.081 mm (0.0005-0.0032 in.)	0.08-0.13 mm (0.003-0.005 in.)	0.013-0.081 mm (0.0005-0.0032 in.)
<b>Crankshaft Crankpin—</b>				
Diameter .....	57.11-57.12 mm (2.2485-2.2490 in.)	49.49-49.21 mm (1.9365-1.9375 in.)	57.11-57.12 mm (2.2485-2.2490 in.)	49.19-49.21 mm (1.9365-1.9375 in.)
Bearing Clearance .....	0.06-0.10 mm (0.0025-0.0040 in.)	0.015-0.078 mm (0.0006-0.0031 in.)	0.06-0.10 mm (0.0025-0.0040 in.)	0.015-0.078 mm (0.0006-0.0031 in.)
<b>Crankshaft End Play.....</b>	0.05-0.38 mm (0.002-0.015 in.)	0.10-0.20 mm (0.004-0.008 in.)	0.05-0.38 mm (0.002-0.015 in.)	0.10-0.20 mm (0.004-0.008 in.)
<b>Camshaft Journal Diameter—</b>				
Front.....	47.47-47.50 mm (1.869-1.870 in.)	45.92-45.95 mm (1.808-1.809 in.)	47.47-47.50 mm (1.869-1.870 in.)	45.92-45.95 mm (1.808-1.809 in.)
Center.....	47.22-47.24 mm (1.859-1.860 in.)	44.34-44.36 mm (1.745-1.746 in.)	47.22-47.24 mm (1.859-1.860 in.)	44.34-44.36 mm (1.745-1.746 in.)
Rear .....	46.71-46.74 mm (1.839-1.840 in.)	42.75-42.77 mm (1.683-1.684 in.)	46.71-46.74 mm (1.839-1.840 in.)	42.75-42.77 mm (1.683-1.684 in.)
<b>Camshaft Bearing Clearance .....</b>	0.10-0.20 mm (0.004-0.008 in.)	0.065-0.115 mm (0.0025-0.0045 in.)	0.10-0.20 mm (0.004-0.008 in.)	0.065-0.115 mm (0.0025-0.0045 in.)
<b>Piston Pins—</b>				
Diameter .....	31.744-31.750 mm (1.2498-1.2500 in.)	21.821-21.826 mm (0.8591-0.8593 in.)	31.744-31.750 mm (1.2498-1.2500 in.)	21.821-21.826 mm (0.8591-0.8593 in.)
Clearance in Bushing .....	0.01-0.04 mm (0.0004-0.0017 in.)	0.005-0.015 mm (0.0002-0.0006 in.)	0.01-0.04 mm (0.0004-0.0017 in.)	0.005-0.015 mm (0.0002-0.0006 in.)

### TIGHTENING TORQUES\*\*

	95-101 N·m (70-75 ft.-lbs.)		95-101 N·m (70-75 ft.-lbs.)	
Cylinder Head .....	Refer to Text	54-61 N·m (40-45 ft.-lbs.)	Refer to Text	54-61 N·m (40-45 ft.-lbs.)
Connecting Rods.....	Refer to Text	54-61 N·m (40-45 ft.-lbs.)	Refer to Text	54-61 N·m (40-45 ft.-lbs.)
Main Bearings .....	149-156 N·m (110-115 ft.-lbs.)	115-129 N·m (85-95 ft.-lbs.)	149-156 N·m (110-115 ft.-lbs.)	115-129 N·m (85-95 ft.-lbs.)
Flywheel .....	101-108 N·m (75-80 ft.-lbs.)	95-101 N·m (70-75 ft.-lbs.)	101-108 N·m (75-80 ft.-lbs.)	95-101 N·m (70-75 ft.-lbs.)
Oil Pan .....	26-28 N·m (19-21 ft.-lbs.)	16-22 N·m (12-16 ft.-lbs.)	26-28 N·m (19-21 ft.-lbs.)	16-22 N·m (12-16 ft.-lbs.)
Intake Manifold .....	8-12 N·m (6-9 ft.-lbs.)	27-41 N·m (20-30 ft.-lbs.)	8-12 N·m (6-9 ft.-lbs.)	27-41 N·m (20-30 ft.-lbs.)
Exhaust Manifold.....	16-20 N·m (12-15 ft.-lbs.)	27-41 N·m (20-30 ft.-lbs.)	16-20 N·m (12-15 ft.-lbs.)	27-41 N·m (20-30 ft.-lbs.)

\*\* Torque figures apply with threads clean and lightly oiled.

## CONDENSED SERVICE DATA

GENERAL	MF240	MF245		MF250
	Diesel	Diesel	Gasoline	Diesel
Engine Make .....	Perkins	Perkins	Continental	Perkins
Engine Model .....	AD3.152	AD3.152	Z-145	AD3.152
Number of Cylinders .....	3	3	4	3
Bore .....	91.44 mm (3.6 in.)	91.44 mm (3.6 in.)	85.72 mm (3.375 in.)	91.44 mm (3.6 in.)
Stroke .....	127.0 mm (5.0 in.)	127.0 mm (5.0 in.)	103.2 mm (4.063 in.)	127.0 mm (5.0 in.)
Displacement .....	2.5 L (152 cu. in.)	2.5 L (152 cu. in.)	2.4 L (145 cu. in.)	2.5 L (152 cu. in.)
Cylinder Sleeves.....	Dry	Dry	Wet	Dry
Electrical System .....	12 Volt, Negative Ground			

	MF240 Diesel	Diesel	MF245 Gasoline	MF250 Diesel
<b>TUNE-UP</b>				
Firing Order .....	1-2-3	1-2-3	1-3-4-2	1-2-3
Valve Clearance, Cold—				
Intake .....	0.30 mm (0.012 in.)	0.30 mm (0.012 in.)	0.33 mm (0.013 in.)	0.30 mm (0.012 in.)
Exhaust .....	0.30 mm (0.012 in.)	0.30 mm (0.012 in.)	0.38 mm (0.015 in.)	0.30 mm (0.012 in.)
Valve Clearance, Hot—				
Intake .....	0.25 mm (0.010 in.)	0.25 mm (0.010 in.)	0.28 mm (0.011 in.)	0.25 mm (0.010 in.)
Exhaust .....	0.25 mm (0.010 in.)	0.25 mm (0.010 in.)	0.33 mm (0.013 in.)	0.25 mm (0.010 in.)
Valve Face Angle—				
Intake .....	35°	45°	30°	35°
Exhaust .....	35°	45°	44°	35°
Valve Seat Angle—				
Intake .....	35°	45°	30°	35°
Exhaust .....	35°	45°	45°	35°
Injection Timing, Static .....	24° BTDC	16° BTDC	....	16° BTDC
Injector Opening Pressure—				
New .....	18755 kPa (2720 psi)	18755 kPa (2720 psi)	....	18755 kPa (2720 psi)
Used .....	17720 kPa (2570 psi)	17240 kPa (2500 psi)	....	17720 kPa (2570 psi)
Ignition Timing .....	....	....	8° BTDC	....
Ignition Point Gap .....	....	....	0.45-0.55 mm (0.017-0.022 in.)	....
Spark Plug Gap .....	....	....	0.63 mm (0.025 in.)	....
Governed Speeds, Engine Rpm—				
Low Idle .....	725-775	725-775	725-775	725-775
High Idle .....	2135-2185	2400-2450	2425-2500	2400-2450
Full Load .....	2000	2250	2250	2250
Rated Power at Pto Shaft .....	25.9 kW (34.8 hp)	32.0 kW (42.9 hp)	30.5 kW (41 hp)	30.4 kW (40.8 hp)
<b>CAPACITIES</b>				
Cooling System .....	9.9 L (10.5 U.S. qts.)	9.9 L (10.5 U.S. qts.)	9.5 L (10 U.S. qts.)	9.9 L (10.5 U.S. qts.)
Crankcase* .....	5.9 L (6.2 U.S. qts.)	4.7 L (5 U.S. qts.)	4.7 L (5 U.S. qts.)	5.9 L (6.2 U.S. qts.)
Hydraulic System .....	32.5 L (8.6 U.S. gals.)	30.3 L (8 U.S. gals.)	30.3 L (8 U.S. gals.)	41.8 L (11 U.S. gals.)
Power Steering .....	0.95 L (1 U.S. qt.)			
Fuel Tank .....	47.9 L (12.6 U.S. gals.)	53 L (14 U.S. gals.)	53 L (14 U.S. gals.)	47.9 L (12.6 U.S. gals.)
* Add 0.95 L (1 U.S. quart) if filter is changed.				
<b>SIZES—CLEARANCES</b>				
Crankshaft Main Journal—				
Diameter .....	69.81-69.83 mm (2.7485-2.7493 in.)	69.81-69.83 mm (2.7485-2.7492 in.)	57.13-57.15 mm (2.249-2.250 in.)	69.81-69.83 mm (2.7485-2.7493 in.)
Bearing Clearance .....	0.05-0.11 mm (0.002-0.004 in.)	0.08-0.13 mm (0.003-0.005 in.)	0.013-0.081 mm (0.0005-0.0032 in.)	0.05-0.11 mm (0.002-0.004 in.)
Crankshaft Crankpin—				
Diameter .....	57.11-57.12 mm (2.2485-2.2490 in.)	57.11-57.12 mm (2.2485-2.2490 in.)	49.19-49.21 mm (1.9365-1.9375 in.)	57.11-57.12 mm (2.2485-2.2490 in.)
Bearing Clearance .....	0.06-0.10 mm (0.0025-0.0040 in.)	0.06-0.10 mm (0.0025-0.0040 in.)	0.015-0.078 mm (0.0006-0.0031 in.)	0.06-0.10 mm (0.0025-0.0040 in.)
Crankshaft End Play .....	0.05-0.38 mm (0.002-0.015 in.)	0.05-0.38 mm (0.002-0.015 in.)	0.10-0.20 mm (0.004-0.008 in.)	0.05-0.38 mm (0.002-0.015 in.)
Camshaft Journal Diameter—				
Front .....	47.47-47.50 mm (1.869-1.870 in.)	47.47-47.50 mm (1.869-1.870 in.)	45.92-45.95 mm (1.808-1.809 in.)	47.47-47.50 mm (1.869-1.870 in.)
Center .....	47.22-47.24 mm (1.859-1.860 in.)	47.22-47.24 mm (1.859-1.860 in.)	44.34-44.36 mm (1.745-1.746 in.)	47.22-47.24 mm (1.859-1.860 in.)

	MF240 Diesel	Diesel	MF245 Gasoline	MF250 Diesel
<b>SIZES—CLEARANCES (Cont.)</b>				
Rear .....	46.71-46.74 mm (1.839-1.840 in.)	46.71-46.74 mm (1.839-1.840 in.)	42.75-42.77 mm (1.683-1.684 in.)	46.71-46.74 mm (1.839-1.840 in.)
Camshaft Bearing Clearance .....	0.10-0.20 mm (0.004-0.008 in.)	0.10-0.20 mm (0.004-0.008 in.)	0.065-0.115 mm (0.0025-0.0045 in.)	0.10-0.20 mm (0.004-0.008 in.)
<b>Piston Pins—</b>				
Diameter .....	31.744-31.750 mm (1.2498-1.2500 in.)	31.744-31.750 mm (1.2498-1.2500 in.)	21.821-21.826 mm (0.8591-0.8593 in.)	31.744-31.750 mm (1.2498-1.2500 in.)
Clearance in Rod Bushing .....	0.01-0.04 mm (0.0004-0.0017 in.)	0.01-0.04 mm (0.0004-0.0017 in.)	0.005-0.015 mm (0.0002-0.0006 in.)	0.01-0.04 mm (0.0004-0.0017 in.)

**TIGHTENING TORQUES\*\***

Cylinder Head .....	95 N·m (70 ft.-lbs.)	95 N·m (70 ft.-lbs.)	95-101 N·m (70-75 ft.-lbs.)	95 N·m (70 ft.-lbs.)
Connecting Rods .....	Refer to Text		54-61 N·m (40-45 ft.-lbs.)	Refer to Text
Main Bearings .....	150 N·m (110 ft.-lbs.)	150 N·m (110 ft.-lbs.)	115-129 N·m (85-95 ft.-lbs.)	150 N·m (110 ft.-lbs.)
Flywheel .....	105 N·m (78 ft.-lbs.)	105 N·m (78 ft.-lbs.)	95-101 N·m (70-75 ft.-lbs.)	105 N·m (78 ft.-lbs.)
Oil Pan .....	18 N·m (14 ft.-lbs.)	18 N·m (14 ft.-lbs.)	16-22 N·m (12-16 ft.-lbs.)	18 N·m (14 ft.-lbs.)
Intake Manifold .....	18 N·m (14 ft.-lbs.)	18 N·m (14 ft.-lbs.)	27-41 N·m (20-30 ft.-lbs.)	18 N·m (14 ft.-lbs.)
Exhaust Manifold .....	18 N·m (14 ft.-lbs.)	18 N·m (14 ft.-lbs.)	27-41 N·m (20-30 ft.-lbs.)	18 N·m (14 ft.-lbs.)

\*\* Torque figures apply with threads clean and lightly oiled.

## FRONT SYSTEM

### AXLE ASSEMBLY

**All Models**

1. Several different front axles are used as shown in Figs. 1,2,3,4 and 5.

Axle extension (7—Fig. 1,2,3 and 5) can be removed from adjustable axle models by first disconnecting drag link and/or tie rod and power steering cylinder (if so equipped) from steering arm. Remove bolts attaching axle extension to center member (5), then withdraw axle extension. To remove center member (5), first

support front of tractor and remove hood, side panels, grille support frame, radiator and axle extensions (if so equipped). Disconnect hydraulic lines from power steering cylinders (if so equipped). Remove axle pivot pin retaining screw (4) and inner snap ring (3). Withdraw pivot pin and remove axle center

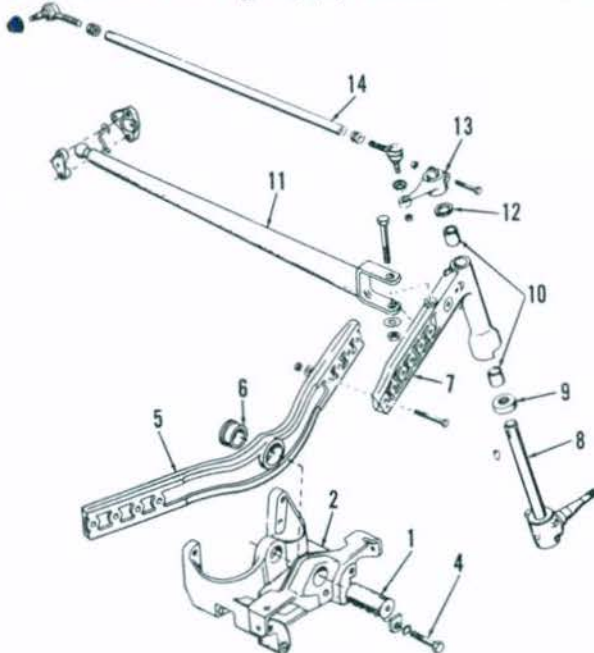

Fig. 1—Exploded view of swept back axle used on some MF230 and MF235 models. Refer to Fig. 2 for legend except radius rods (11).

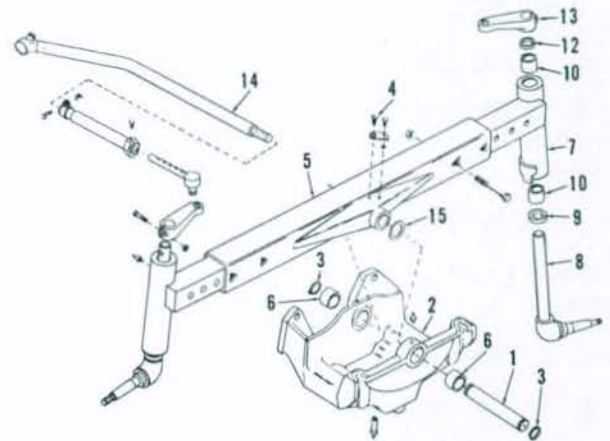
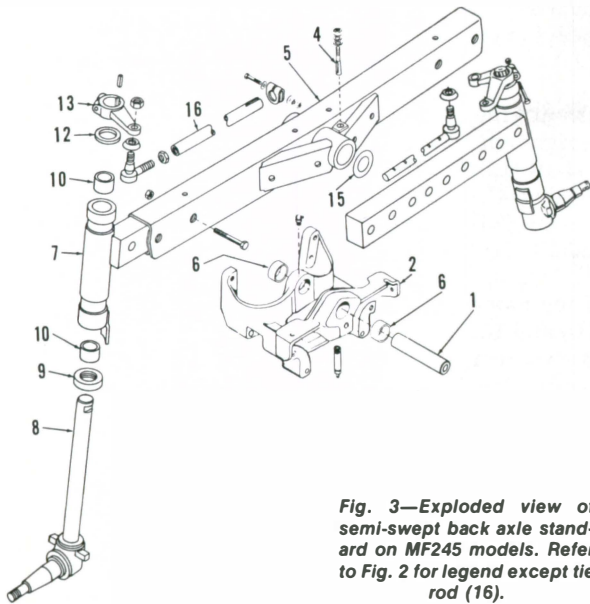
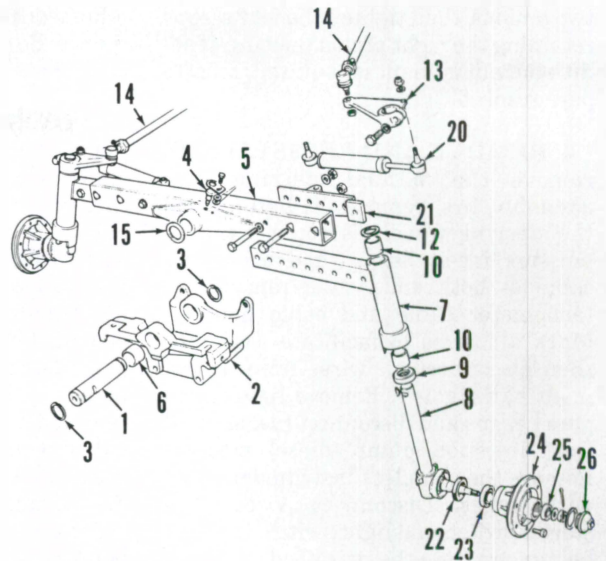

Fig. 2—Exploded view of typical straight axle standard on MF235 models and all Vineyard models.

- |                              |                   |                  |
|------------------------------|-------------------|------------------|
| 1. Pivot pin                 | 6. Bushing        | 12. Dust seal    |
| 2. Front support             | 7. Axle extension | 13. Steering arm |
| 3. Snap ring                 | 8. Spindle        | 14. Drag link    |
| 4. Pivot pin retaining screw | 9. Bearing        | 15. Shim         |
| 5. Axle center member        | 10. Bushing       |                  |

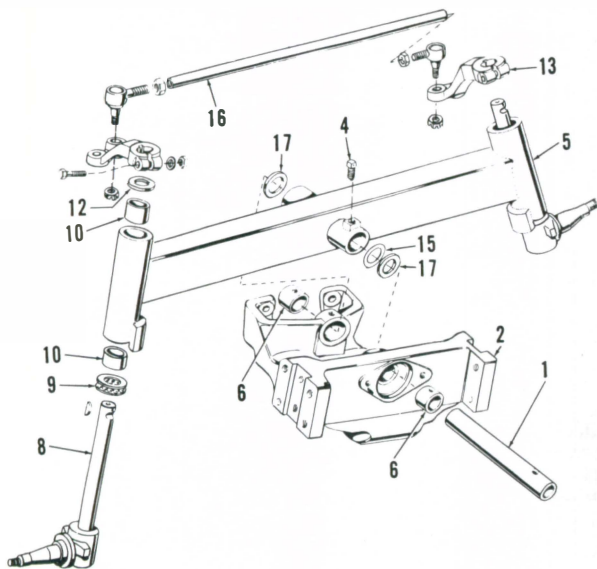

**Fig. 3—Exploded view of semi-swept back axle standard on MF245 models. Refer to Fig. 2 for legend except tie rod (16).**



**Fig. 5—Exploded view of adjustable front axle assembly used on Models MF240 and MF250. Refer to Fig. 2 for legend except for the following:**

- |                       |                   |                   |
|-----------------------|-------------------|-------------------|
| 20. Steering cylinder | 23. Inner bearing | 25. Outer bearing |
| 21. Cylinder bracket  | 24. Wheel hub     | 26. Hub cap       |
| 22. Seal              |                   |                   |



**Fig. 4—Exploded view of nonadjustable front axle used on MF235 and MF245 Orchard models. Refer to Fig. 2 for legend except for washers (17) and tie rod (16).**

member. Unbolt and remove front support (2) if necessary.

Axle pivot bushings (6) and spindle bushings (10) should be renewed if excessively worn. Pivot bushings (6) should be installed 0.5 mm (0.020 inch) below

flush with inner faces of support housing. Be sure bushings are installed with hole aligned with grease passage. Make certain pivot pin slides freely through bushings after installation. Spindle bushings (10) must be reamed to provide

desired fit to spindle. To reinstall, reverse the removal procedure.

Measure axle center member end play in support housing using a feeler gage. Select shims (15) to provide 0.05-0.25 mm (0.002-0.010 inch) end play. Lubricate with multipurpose lithium base grease.

### TOE-IN, TIE RODS AND/OR DRAG LINKS

#### All Models

2. Automotive type tie rod and drag link ends are used. Units are nonadjustable and should be renewed if excessively worn. Recommended toe-in is 3 mm (1/8 inch). On models with two drag links, adjust each an equal amount to obtain correct toe-in. On models with tie rod (16—Fig. 3 or 4), loosen locknuts and clamps, then turn adjusting sleeve to provide correct toe-in.

## MANUAL STEERING GEAR

This section covers the manual steering gear used on MF230 and MF235 tractors without power assist steering or hydrostatic power steering.

#### All Models So Equipped

#### 3. LUBRICATION AND ADJUSTMENT.

The steering gear should be

filled to the level of the opening for plug (25—Fig. 6) with SAE 90 gear lubricant.

Backlash between the ball nut (20) and left sector gear (10) and between the right and left sector gears (10 and 15) can be adjusted while unit is installed. To adjust, loosen four screws that attach the left and right pinion housings (4L and 4R) to the steering gear housing,

then rotate the right pinion housing (4R) clockwise to the end of the bolt slots. Rotate the left pinion housing (4L) counterclockwise until all backlash is eliminated between left pinion and ball nut, then tighten the four screws retaining left pinion housing. Rotate the right pinion housing counterclockwise until all backlash is eliminated between the

two pinions, then tighten the four screws retaining the right pinion housing. If additional adjustment is required, refer to paragraph 5.

**4. REMOVE AND REINSTALL.** To remove the manual steering gear assembly, first remove the battery and the steering wheel. Disconnect the oil pressure line at the gage and tachometer cable at both ends, then remove the tachometer cable and cable housing. Mark all wires to facilitate assembly, then disconnect all wires from instrument panel gages. Remove lights from panel gages and disconnect fuel shut-off from injection pump (diesel models). Remove the complete instrument panel with gages. Disconnect wires from starter switch and light switch, then unbolt and remove the rear hood assembly with light switch and starter switch installed. Disconnect linkage from both ends of the throttle cross shaft, then slide shaft from left side of tractor. Remove the complete air cleaner assembly and the battery platform. Disconnect drag links from both pitman arms, remove the six retaining screws, then lift the steering gear from the tractor.

Reinstall by reversing the removal procedure. Be careful to connect wires to instruments correctly.

**5. OVERHAUL.** To overhaul the removed unit, first remove the right pinion housing (4R—Fig. 6) and shaft (15), then remove the left pinion housing (4L) and shaft (10). Unbolt shaft housing (24) and withdraw housing and shaft (20). Eleven loose balls should fall from upper bearing (21) and eleven from lower bearing (19). Pitman shafts (10 and 15) and related parts can be withdrawn from housing (4L or 4R) after snap ring (8) is removed as shown in Fig. 7. Parts of the ball nut and shaft (20—Fig. 6) are not available separately and should not be disassembled.

Press new bushings (3, 11 and 17) into bores of respective housings until flush to 0.8 mm (1/32 inch) below flush with outer edge of bore. Assemble parts (6,7,8,9,12 and 13) onto pitman shaft (10) and parts (6,8,9,12,13 and 16) onto pitman shaft (15) before inserting into housings (4L and 4R). Add more shims (12), if necessary, to remove all end play from bearing.

Use grease to hold the eleven balls (19 and 21) into each race, then insert shaft

and ball nut (20) into shaft housing (24). Place shims (22) and "O" ring (23) onto housing (24), then install into steering gear housing (14). Shims (22) are available in 0.13-0.25 mm (0.005-0.010 inch). Install only enough shims to provide 0.03-0.13 mm (0.001-0.005 inch) preload for bearings (19 and 21).

After steering shaft ball nut is installed, turn the steering shaft until the ball nut is at bottom. Position the steering gear as normally installed on the tractor, and install the left pitman shaft (10) and housing (4L) assembly. The flat identification boss on left housing (4L) should be down when installed. The marked (3rd) tooth on left pinion (10) should be aligned with center valley of ball nut rack (20) as shown in Fig. 8. Turn the steering shaft until ball nut is moved to top and install the right pitman shaft (15—Fig. 6) and housing (4R) assembly. The first tooth on right pinion (15) should be aligned with the first valley on left pinion (10) as shown in Fig. 9. The flat identification boss on right housing (4R—Fig. 6) should be toward front when installed correctly.

To adjust the backlash, rotate the right pinion housing (4R) clockwise to end of bolt slots and temporarily tighten retaining screw. Rotate the left pinion housing (4L) counterclockwise until all

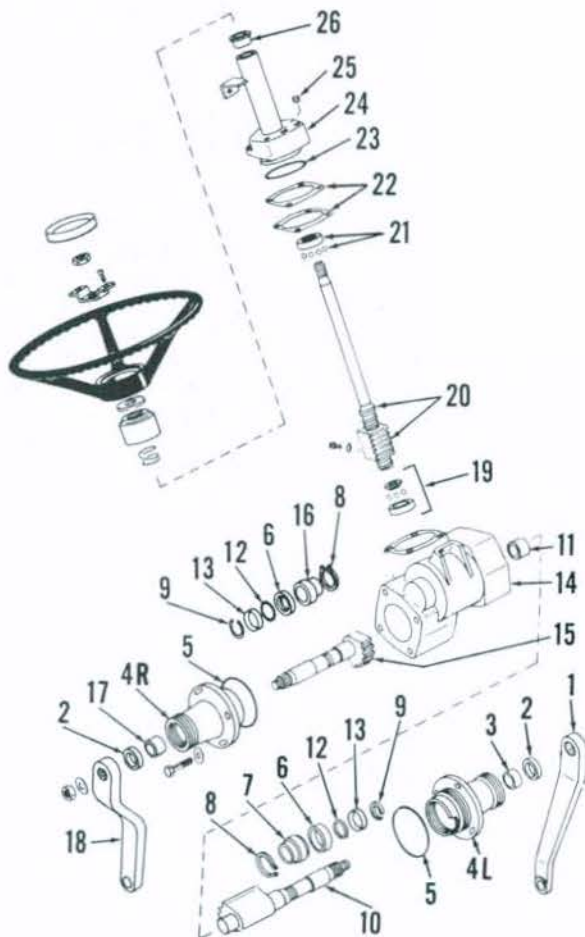

Fig. 6—Exploded view of typical manual steering gear used on MF230 and some MF235 models.

- 1. Left pitman arm
- 2. Oil seal
- 3. Bushing
- 4L. Left pinion housing
- 4R. Right pinion housing
- 5. "O" ring
- 6. Bearing
- 7. Left sleeve
- 8. Snap ring
- 9. Clip
- 10. Left pitman shaft
- 11. Bushing
- 12. Shim
- 13. Retainer
- 14. Steering gear housing
- 15. Right pitman shaft
- 16. Right sleeve
- 17. Bushing
- 18. Right pitman arm
- 19. Lower bearing
- 20. Shaft & ball nut
- 21. Upper bearing
- 22. Shims
- 23. "O" ring
- 24. Shaft housing
- 25. Fill plug
- 26. Top bushing



Fig. 7—The snap ring must be removed as shown before pitman shaft can be removed from housing.

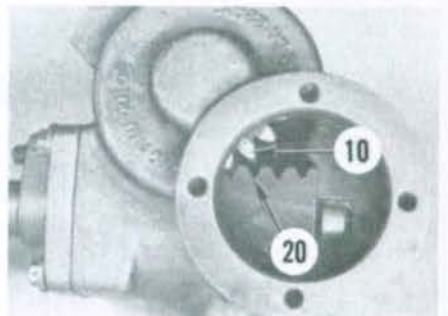

Fig. 8—The marked (3rd) tooth of the left pinion gear (10) should be aligned with the center valley of rack (20).

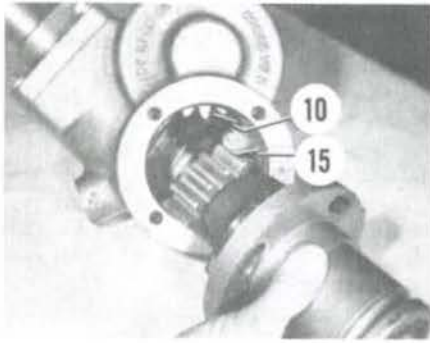

Fig. 9—Install the right pinion with first tooth (15) aligned with first valley (10) on the other pinion.

backlash is eliminated, then tighten the four housing retaining screws. Rotate the right pinion housing (4R) counterclockwise until all backlash is removed from the right pitman shaft, then tighten the four retaining screws. Check for correct assembly by locating the center (straight ahead) position of the steering shaft (20). With steering shaft straight ahead, the blank splines on both pitman shafts (10 and 15) should be vertical. The small flat mounting boss at rear of steering gear housing will also be vertical when installed on tractor. Fill steering gear housing to level of plug (25) with SAE 90 gear oil.

Reinstall reservoir, refill with oil and recheck pressure after changing relief valve setting.

**POWER STEERING PUMP**

The pump shown in exploded view Fig. 10 is used on diesel models; the pump in Fig. 11 on gasoline models. Refer to the appropriate following paragraphs for service.

**All Models**

**8. REMOVE AND REINSTALL.** Clean the area thoroughly before disconnecting any lines. Disconnect lines, remove mounting screws and withdraw pump.

When reinstalling, tighten retaining bolts to 27 N · m (20 ft.-lbs.) torque. Refill reservoir with fluid and bleed air from system as outlined in paragraph 6.

**Diesel Models**

**9. OVERHAUL.** Mark the pump housing (8—Fig. 10) and reservoir (27) before removing reservoir. Filter (16) can be removed after reservoir. Remove nut, gear (1), key and spacer (2). Establish the setting of the relief valve plug (24) before removing the plug. Remove the screws attaching body (17) and shield (20) to the housing (8). Remove gears (10 and 11), Woodruff key (6), idler shaft (13) and pin

**POWER ASSIST STEERING SYSTEM**

This section covers the power steering system available on Models MF230, MF235 (except Orchard), MF240, MF245 Vineyard and MF250.

**LUBRICATION AND BLEEDING**

**All Models So Equipped**

6. Recommended oil for power steering system is Massey-Ferguson Permatran III Oil. Check power steering reservoir oil level with engine running after all air is bled from system. Power steering system capacity is approximately 0.95 L (1 U.S. quart).

Air can be bled from power steering system by running engine and cycling steering from full left to full right, then back to full left several times. Repeat until there are no air bubbles present in oil reservoir. Make certain oil level is maintained during bleeding process to avoid starving the pump of oil.

**SYSTEM OPERATING PRESSURE AND RELIEF VALVE**

**All Models So Equipped**

7. A pressure test of steering hydraulic system will disclose whether the pump relief valve or some other unit in the system is malfunctioning. To check relief pressure, install a "T" fitting at pump pressure port, reattach pressure hose to one port of "T" and a 20000 kPa (3000 psi) pressure gage to the other port. Start engine and operate at 2000 rpm. Turn steering wheel to full turn in either direction and observe gage pressure reading. Normal relief pressure is approximately 8300 kPa (1200 psi).

The relief valve on models equipped with gasoline engine is adjusted after

removing reservoir (27—Fig. 11) and turning screw (24). The relief valve on models equipped with diesel engine is also adjusted after removing reservoir (27—Fig. 10) and turning adjusting screw (24). One full turn of relief valve screw should change pressure approximately 2100 kPa (300 psi) on Models MF230, MF235 and MF245. On Models MF240 and MF250, a pressure change of approximately 3100 kPa (450 psi) should result from one turn of adjusting screw.

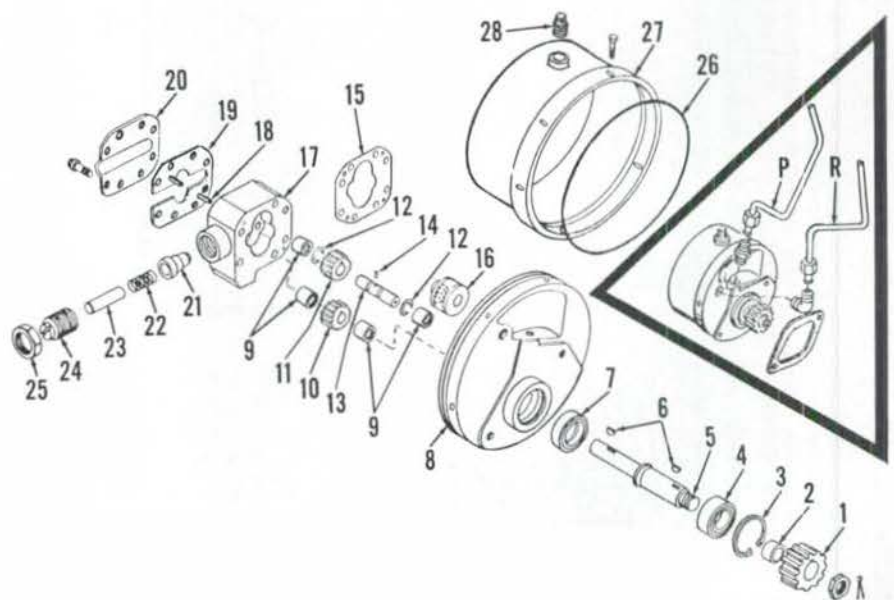

Fig. 10—Exploded view of power steering pump used on Models MF230, MF235 and MF245 equipped with diesel engine. Pump used on Models MF240 and MF250 is similar except dual springs are used on relief valve and spring guide pin (23) is not used. Inset shows location of pressure line (P) and return line (R).

- |                  |                    |                    |                           |
|------------------|--------------------|--------------------|---------------------------|
| 1, Gear          | 8. Housing         | 15. Gasket         | 22. Spring                |
| 2. Spacer        | 9. Needle bearings | 16. Filter         | 23. Pin                   |
| 3. Snap ring     | 10. Drive gear     | 17. Body           | 24. Relief adjusting plug |
| 4. Bearing       | 11. Driven gear    | 18. Dowel pins     | 25. Nut                   |
| 5. Shaft         | 12. Rings          | 19. Gasket         | 26. "O" ring              |
| 6. Woodruff keys | 13. Idler shaft    | 20. Shield         | 27. Reservoir             |
| 7. Seal          | 14. Pin            | 21. Relief plunger | 28. Fill plug             |



(14). Remove snap ring (3), then bump shaft (5) and bearing (4) out front of housing bore.

Inspect all parts for scoring, wear or other damage and renew if necessary. Always renew all "O" rings, gaskets and oil seal.

Install new oil seal (7) with lip facing inward and front of seal flush with outer surface of housing. When renewing needle bearings (9), press against numbered side of bearing. Bearings should be slightly below flush with machined surface of housing. Press bearing (4) onto shaft (5), then install the shaft and bearing in bore of housing (8). Install snap ring (3), spacer (2), key (6) and gear (1), then install retaining nut. Install the other key (6) in shaft and slide gear (10) onto key (6) in shaft and slide gear (10) onto shaft over the key. Install the idler

shaft and gear assembly (11, 12, 13 and 14). Position thin gasket (15) around gears and locate body (17) over gears being careful not to damage the gasket. Install the thicker gasket (19) and plate (20) and tighten the assembly screws to 11-14 N · m (8-10 ft.-lbs.) torque. Use care when assembling relief valve (21, 22, 23, 24 and 25). Install the adjusting plug (24) as near as possible to position from which it was removed. Reinstall pump and check relief pressure as outlined in paragraph 7.

**Gasline Models**

**10. OVERHAUL.** Remove reservoir cover (29—Fig. 11), filter (16), stud (30) and screw (31), then lift off reservoir (27). Establish the setting of the relief valve plug (24) before removing plug. Remove

screws attaching body (17) to the housing (8) and remove body. Remove gears (10 and 11), Woodruff key (6), idler shaft (13) and pin (14). Remove nut, gear (1), sleeve (2) and snap ring (3), then bump shaft (5) and bearing (4) out front of housing.

Install new seal (7) with lip toward rear of pump and front of seal flush with the step in front of housing bore. Press new bearings (9) into bores in body (17) and housing (8) until bearing is just below flush. Press only on numbered side of bearing which should be toward gears (10 and 11). Press bearing (4) onto shaft (5), then install the shaft and bearing in bore of housing (8). Install snap ring (3), spacer (2), key (6) and gear (1), then install retaining nut. Install other key (6) in shaft and slide gear (10) onto shaft over key. Install the idler shaft and gear assembly (11, 12, 13 and 14). Position gasket (15) around gears and locate body (17) over gears being careful not to damage gasket. Install and tighten assembly screws to 11-14 N · m (8-10 ft.-lbs.) torque. Install relief valve (21, 22, 23 and 24). Install plug (24) as near as possible to original location to facilitate relief setting. Reinstall pump and check relief valve pressure setting as outlined in paragraph 7.

**STEERING GEAR AND CONTROL VALVE**

**Models MF230-MF235-MF245**

The steering gear assembly includes the power steering control valve, power assist piston and cylinder as well as steering shaft, rack, and pitman shafts necessary for manual steering.

**11. REMOVE AND REINSTALL.** To remove the power steering gear, first remove the battery and the steering wheel. Disconnect the oil pressure line at gage and tachometer cable at both ends, then remove the tachometer cable and cable housing. Mark all wires to facilitate reassembly, then disconnect all wires from instrument panel gages. Remove lights from panel gages and disconnect fuel shut-off from injection pump (diesel models). Remove the complete instrument panel with gages. Disconnect wires from starter switch and light switch, then unbolt and remove the rear hood assembly with starter and light switches installed. Disconnect linkage from both ends of the throttle cross shaft, then slide shaft from left side of tractor. Remove the complete air cleaner assembly and the battery platform. Clean the area thoroughly before disconnecting any power steering lines. Disconnect hydraulic lines and plug all openings to prevent entrance of

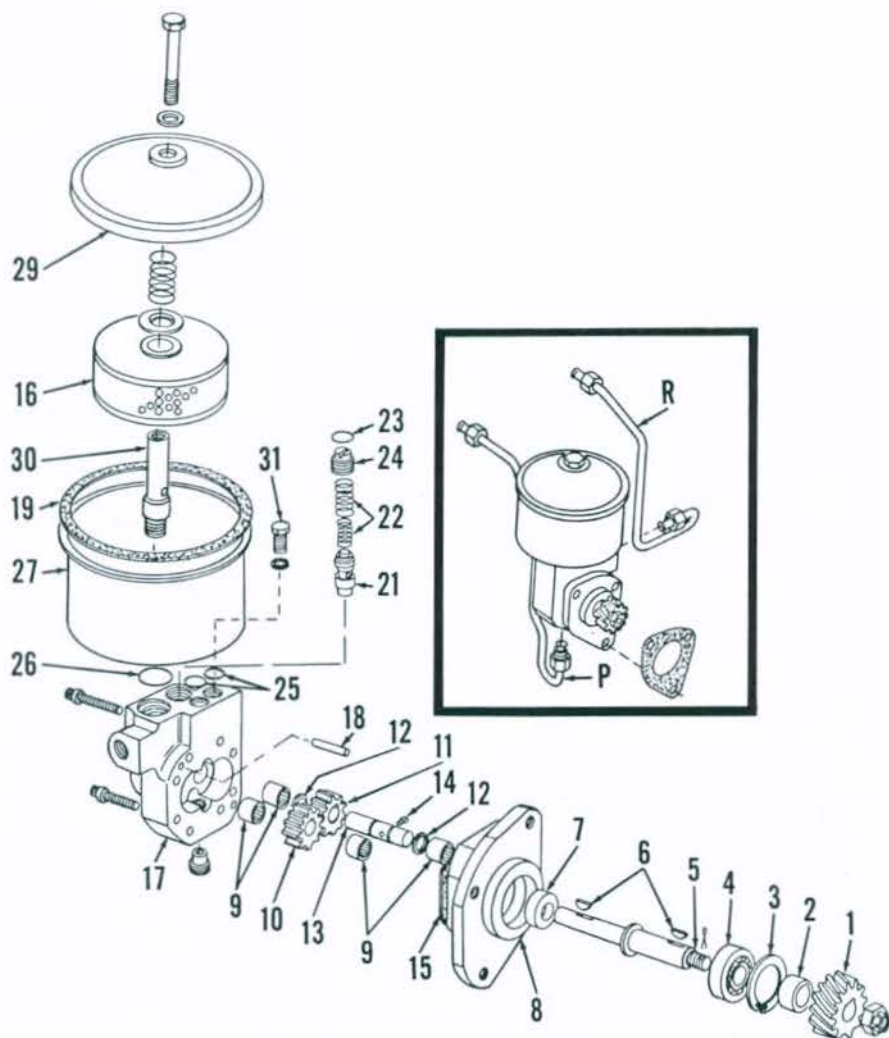

Fig. 11—Exploded view of power steering pump used on Models MF230, MF235 and MF245 equipped with gasoline engine. Inset shows location of pressure line (P) and return line (R).

- |                  |                    |                           |               |
|------------------|--------------------|---------------------------|---------------|
| 1. Gear          | 9. Needle bearings | 17. Body                  | 25. "O" rings |
| 2. Spacer        | 10. Drive gear     | 18. Dowel pin             | 26. "O" ring  |
| 3. Snap ring     | 11. Driven gear    | 19. Gasket                | 27. Reservoir |
| 4. Bearing       | 12. Rings          | 21. Relief plunger        | 29. Cover     |
| 5. Shaft         | 13. Idler shaft    | 22. Springs               | 30. Stud      |
| 6. Woodruff keys | 14. Pin            | 23. "O" ring              | 31. Screw     |
| 7. Seal          | 15. Gasket         | 24. Relief adjusting plug |               |
| 8. Housing       | 16. Filter         |                           |               |

dirt. Disconnect drag links from both pitman arms, remove the six retaining screws, then lift the steering gear from the tractor.

Reinstall reversing the removal procedure. Be careful to connect wires to instruments correctly. Bleed the hydraulic system as outlined in paragraph 6 after all lines are connected. Be sure that pump is not allowed to operate without fluid.

**12. OVERHAUL.** To overhaul the removed unit, unbolt right side pinion housing (49—Fig. 12) and remove pitman shaft (48), housing (49) and related parts. Turn unit over and drain oil from housing, then unbolt and remove the left pinion housing (44), pitman shaft (36) and related parts. Mark control valve head (1), valve body (14), bearing housing (20) and steering gear housing (34) before disassembly to facilitate correct reassembly. Unbolt and remove control valve housing, head, bearing housing, steering shaft and rack unit. Unscrew piston (27) and rack (32) as a unit from shaft (31), then remove bearing housing (20).

To disassemble control valve and steering shaft, use caution and carefully identify parts as they are removed. Some parts used may be slightly different than shown in Fig. 12. Remove top snap ring (3), washer (4) and seal (5). Remove second snap ring (3) and lift parts (6,7,8,9 and 10) from shaft. Remove valve body (14) from valve spool (18). Be careful not to lose or damage parts of plungers (11). Remove return fitting and adapter (17), being careful not to lose check ball (15).

Pitman shafts (36 and 48) and related parts can be withdrawn from housings (44 and 49) after snap ring (37) is removed as shown in Fig. 13.

Inspect all parts for wear or damage and renew if necessary. Install new seal (2—Fig. 12) in head (1) with lip of seal towards valve body and end of seal flush with edge of housing bore. Press new bushings (35 and 45) into housings until flush to 0.8 mm (1/32 inch) below flush with outer edge of bore. Lips of seals (46) should face inward. Some models use a washer and snap ring to retain seals (46) in housings. When renewing "O" rings (21 and 29) and seals (22 and 30) in bearing housing, be sure "O" rings are installed under the seal rings.

Assemble lower snap ring (3), washers (6,8 and 10), bearings (9) and spool (18) onto steering shaft. Install shims (7) until upper snap ring (3) will just fit into groove in shaft. End play of spool (18) on shaft must be less than 0.076 mm (0.003 inch). Remove upper snap ring, washers and thrust bearing from shaft after correct end play is obtained. Install check ball (15) and fitting (17) in valve body.

Temporarily thread piston (27) and rack (32) onto shaft (31). Install lower snap ring (3), lower thrust bearing (8,9 and 10) and valve spool (18) onto shaft. The groove inside valve spool (18) must be towards top (steering wheel) end of shaft. Install centering springs (12) and plungers (11), then carefully install valve body (14). Install upper thrust bearing (10,9 and 8), shims (7), washers (6) and snap ring (3). The centering springs will make it difficult to install the snap ring into its groove, however, a 25x110 mm (1x4-1/4 inch) piece of pipe can be used as shown in Fig. 14 to push snap ring in-

to place. Install washer (4—Fig. 12) with chamfer down over snap ring. Install top snap ring (3). Remove piston and rack from shaft.

Install bearing housing (20) over shaft being sure that "O" rings at (R) are aligned with corresponding holes in control valve body. Install piston and rack onto shaft. Install head (1) over shaft aligning scribe marks made prior to disassembly.

Install control valve, steering shaft, piston and rack assembly into the steering gear housing as shown in Fig. 15. Be careful not to damage piston seal ring,

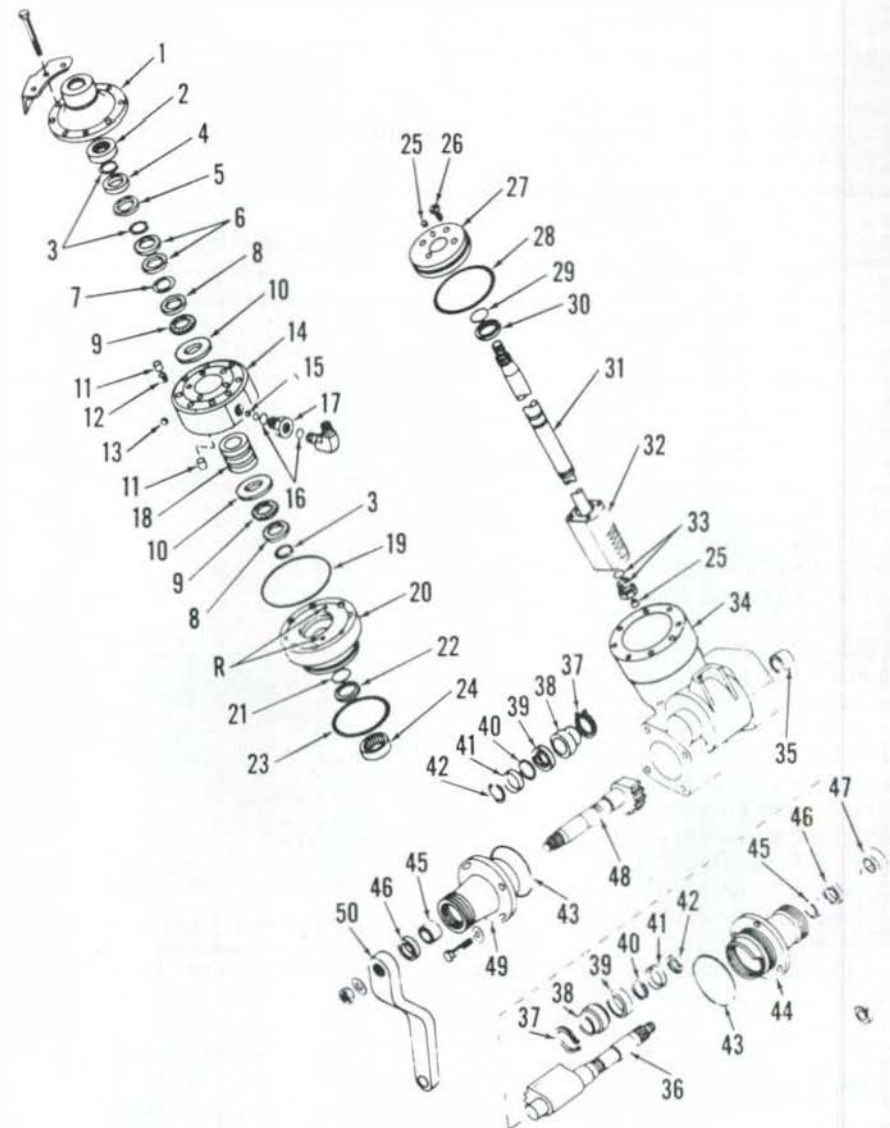

Fig. 12—Exploded view of power steering gear available on all MF230 models, all MF235 models except Orchard end MF245 Vineyard models.

- |                   |                     |                       |                          |
|-------------------|---------------------|-----------------------|--------------------------|
| 1. Head Assy.     | 14. Valve body      | 26. Screws            | 38. Spacer               |
| 2. Seal           | 15. Ball            | 27. Piston            | 39. Bearing              |
| 3. Snap rings     | 16. "O" rings       | 28. Piston ring       | 40. Shims                |
| 4. Washer         | 17. Adapter         | 29. "O" ring          | 41. Cover                |
| 5. Nylon seal     | 18. Valve spool     | 30. Seal ring         | 42. Snap ring            |
| 6. Washers        | 19. "O" ring        | 31. Steering shaft    | 43. "O" ring             |
| 7. Shims          | 20. Bearing housing | 32. Rack              | 44. Left pinion housing  |
| 8. Race           | 21. "O" ring        | 33. Plug & "O" ring   | 45. Bushing              |
| 9. Bearing        | 22. Seal ring       | 34. Housing           | 46. Seal                 |
| 10. Thrust washer | 23. "O" ring        | 35. Bushing           | 47. Left pitman arm      |
| 11. Plunger       | 24. Bearing         | 36. Left pitman shaft | 48. Right pitman shaft   |
| 12. Spring        | 25. Valve           | 37. Snap ring         | 49. Right pinion housing |
| 13. Ball          |                     |                       | 50. Right pitman arm     |

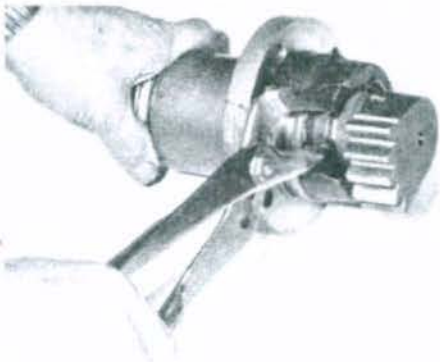

Fig. 13—Snap ring must be removed from housing before pitman shaft can be withdrawn.

and be sure to maintain alignment of housings. Secure in position with retaining screws.

Assemble parts (37, 38, 39, 40, 41 and 42—Fig. 12) onto pitman shafts before installing shafts into pinion housing. Adjust thickness of shims (40) as necessary to remove all end play from bearing (39).

Turn the installed steering shaft (31) until the rack (32) is at bottom of travel position the steering gear housing (34) as normally installed on the tractor and install the left pitman shaft and housing assembly. The flat identification boss on left housing should be down when installed. The marked third tooth on left pinion should be aligned with the center valley of the rack as shown in Fig. 16. Install retaining screws, then turn steering shaft until rack (32) is all the way up in housing. Align the first tooth on right pinion (48—Fig. 17) with first valley on left pinion (36) as shown. The identification boss (B) on right housing should be toward front as installed on tractor. After correct alignment is obtained, the right side pinion housing can be temporarily removed (while maintaining correct alignment) and housing filled through opening to capacity with Massey-Ferguson Permtran Oil or equivalent. Install the right pinion housing and right pitman shaft after filling with oil.

Adjust gear backlash as follows: Rotate the right pinion housing (49—Fig. 12)

clockwise to end of bolt slots and temporarily tighten retaining screw. Rotate the left pinion housing (44) counterclockwise until all backlash is eliminated, then tighten the four housing retaining screws. Rotate the right pinion housing (49) counterclockwise until all backlash is removed from the right pitman shaft, then tighten the four retaining screws.

Check for correct assembly by locating the center (straight ahead) position of the steering shaft (31). With steering shaft straight ahead, the blank splines on both pitman shafts (36 and 48) should be vertical. The small flat mounting boss at rear of steering gear housing will also be vertical when installed on tractor.

### STEERING GEAR AND CONTROL VALVE

#### Models MF240-MF250

A recirculating ball type steering unit is used on these models. Twin pitman arms transmit steering wheel movement to front wheels. The power steering control valve is mounted on the steering column tube. The valve is manually actuated by movement of the steering wheel to direct pressurized oil to two double-acting cylinders attached to spindle steering arms.

**13. REMOVE AND REINSTALL STEERING GEAR.** To remove steering gear box, first remove steering wheel hub cap and nut. Remove steering wheel



Fig. 15—Align scribe marks made prior to disassembly when assembling control valve, steering shaft, piston and rack assembly.

using a suitable puller. Disconnect battery cables and remove battery. Disconnect fuse box mounting panel. Tag and disconnect electrical wiring between tractor wiring harness and instrument harness. Remove lower instrument panel. Disconnect tachometer cable. Disconnect hand throttle lever from throttle linkage. Remove instrument panel mounting cap screws, then lift instrument panel off the steering column. Remove pitman arms (30 and 49—Fig. 18) using a suitable puller. Disconnect hydraulic lines from power steering valve. Remove cap screws attaching steering box to the side support brackets and to the transmission housing. Shift transmission into neutral, then remove steering gear box with shift levers from the tractor.

To reinstall steering gear box, reverse the removal procedure while noting the following special instructions: Apply gasket maker compound to mounting surface of gear box. Tighten pitman arm retaining nuts to 340 N · m (250 ft.-lbs.) torque. Tighten steering wheel retaining nut to 47 N · m (35 ft.-lbs.) torque.

**14. OVERHAUL STEERING GEAR.** To disassemble the removed unit, first disconnect and remove control valve (22—Fig. 18) from steering column. Remove plug from steering column (21) and drain oil from housing. Unbolt and remove cover plate (40) from housing. Withdraw the secondary pitman shaft (37). Remove retainer plate (45) and shims (44). Unbolt and remove steering column assembly from housing. Remove primary pitman shaft (38) and steel ball (43). Unscrew ball nut (26) from steering shaft (25).

Remove set screw securing housing retainer (16). Slide retainer and felt seal (15) away from steering shaft housing (9), then remove snap ring (20) from its groove. Remove nut (5) and washer (6) from shaft. Remove adjustable race nut (7), then lift housing (9) from shaft. Note

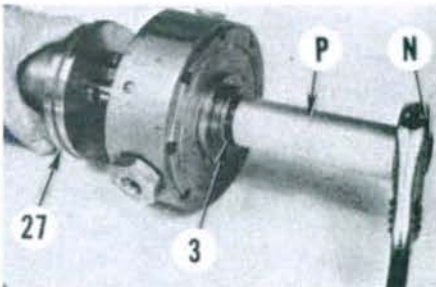

Fig. 14—A 25x110 mm (1x4-1/4 inch) piece of pipe (P) can be used together with steering wheel nut (N) to push snap ring (3) into groove.

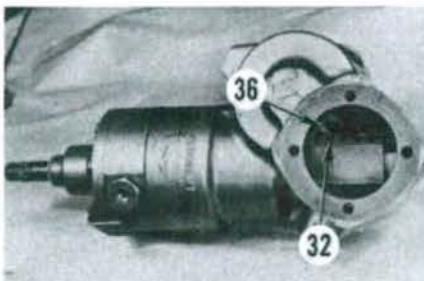

Fig. 16—The marked tooth of the left pinion (36) should be meshed with the center valley of rack (32).

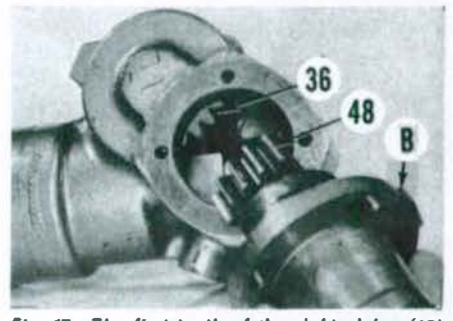

Fig. 17—The first tooth of the right pinion (48) should be meshed with first valley of left pinion (36). Identification boss on housing is shown at (B).

that 12 steel balls (10) are contained in the housing. Withdraw steering shaft (25) from outer column (21). Remove felt seal and retainer from column tube.

Inspect all parts for wear or damage and renew if necessary. Replacement pitman arm bushings (33,36,41 and 46) are semi-finished and inside diameter must be reamed to correct size after installation. Attach cover plate to housing, then ream each pair of bushings using special tool number MF19A reamer. Thoroughly clean housing after reaming to remove all metal particles.

To reassemble, position retainer (16) with a new felt seal (15) on column tube. Insert steering shaft into tube. Assemble the 12 steel balls in outer race of housing (9) using grease to hold balls in place, then carefully slide housing over steering shaft. Install adjustable race nut (7) and tighten to 14 N · m (10 ft.-lbs.) torque, then loosen nut one flat. Install washer (6) and locknut (5) to secure adjustable race nut adjustment.

Thread ball nut (26) onto steering shaft while assembling the 28 steel balls into the nut. Turn the ball nut to top of steering shaft threads. Assemble primary pitman shaft (38) into housing. Use grease to hold steel ball (43) in place in pitman shaft. Insert steering shaft into housing and rotate pitman shaft and ball nut until steel ball is seated in the ball nut. Note that ball transfer tube on ball nut must be facing away from pitman shaft. Install and tighten cap screws attaching steering column tube (21) to housing. Install retainer plate (45) with extra shims (44) to ensure ball nut free play. Turn steering shaft until ball nut is centered on shaft threads, then remove shims as necessary until there is no end play in ball nut but nut still rotates freely. Install secondary pitman shaft (37) and cover plate (40). Refill housing with SAE 90 gear oil.

Install snap ring (20) into groove of column tube. Secure retainer (16) to bearing housing (9) with the set screw. Install control valve (22) with new "O" rings and tighten mounting cap screws to 22-25 N · m (16-18 ft.-lbs.) torque. Reinstall steering box as outlined in paragraph 13. Adjust power steering control valve linkage as outlined in paragraph 15.

**15. REMOVE AND REINSTALL CONTROL VALVE.** To remove control valve, first remove battery cover panel and disconnect battery cables. Unbolt and remove instrument panel lower cover. Disconnect hydraulic lines and control linkage from valve. Remove mounting cap screws and remove valve from steering column.

To reinstall valve, reverse the removal procedure. Be sure to renew "O" rings

in steering column oil ports. Tighten valve mounting cap screws to 22-25 N · m (16-18 ft.-lbs.) torque. Adjust con-

trol valve linkage as follows: Remove pin connecting control linkage to valve spool. Turn steering wheel to the right

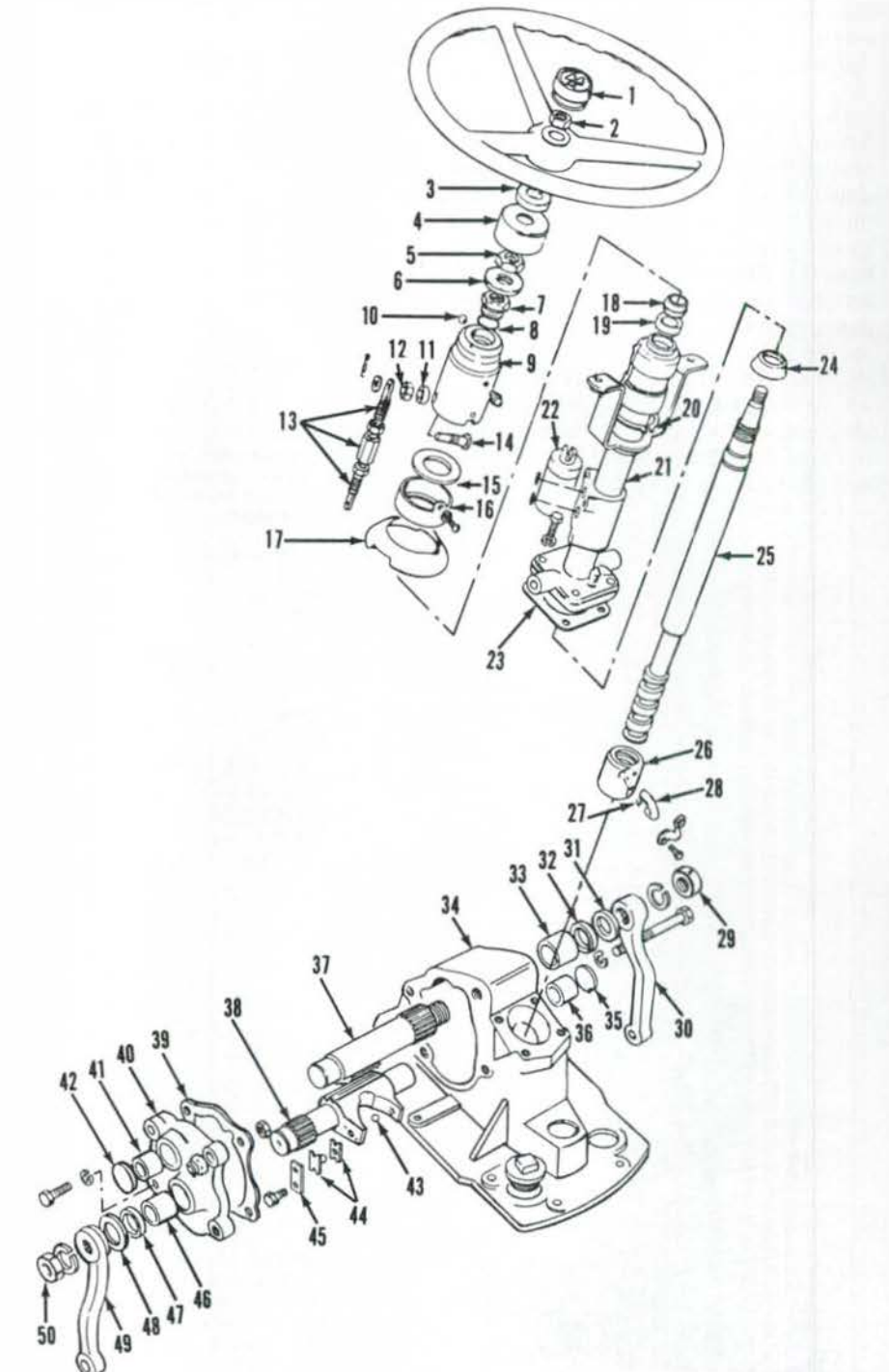

Fig. 18—Exploded view of steering gear assembly used on Models MF240 and MF250.

- |                           |                          |                            |                      |
|---------------------------|--------------------------|----------------------------|----------------------|
| 1. Cap                    | 14. Mounting pin         | 27. Ball (28 used)         | 39. Gasket           |
| 2. Nut                    | 15. Felt washer          | 28. Tube                   | 40. Side cover       |
| 3. Spacer                 | 16. Retainer             | 29. Nut                    | 41. Bushing          |
| 4. Cover                  | 17. Cover                | 30. Pitman arm, R.H.       | 42. Plug             |
| 5. Locknut                | 18. Ball race            | 31. Seal                   | 43. Ball             |
| 6. Washer                 | 19. Seal ring            | 32. Seal                   | 44. Shims            |
| 7. Adjustable race nut    | 20. Snap ring            | 33. Bushing                | 45. Retainer plate   |
| 8. "O" ring               | 21. Steering column tube | 34. Housing                | 46. Bushing          |
| 9. Bearing housing        | 22. Control valve        | 35. Plug                   | 47. Seal             |
| 10. Ball (12 used)        | 23. Gasket               | 36. Bushing                | 48. Seal             |
| 11. Spacer                | 24. Dust seal            | 37. Secondary pitman shaft | 49. Pitman arm, L.H. |
| 12. Nut                   | 25. Steering shaft       | 38. Primary pitman shaft   | 50. Nut              |
| 13. Control valve linkage | 26. Ball nut             |                            |                      |

to remove all free play in steering box without turning the front wheels. Adjust length of linkage until retaining pin can be freely reinserted in spool, then remove pin and increase length of control link by unscrewing rod one full turn. Reattach linkage to valve spool. Start engine and check for full power assistance in both directions.

**16. OVERHAUL CONTROL VALVE.** To disassemble removed unit, remove snap ring (16—Fig. 19), washers and felt seal (15). Remove end cover mounting screws, then withdraw valve spool (7) assembly with end cover (2) and yoke (1). Unscrew yoke from spool and separate springs and washers from spool. Tap bypass piston (10), ball (12) and spring (13) from valve body. Remove relief valve spring and ball (17). Inspect all parts for wear or damage and renew if necessary. Renew all "O" rings when reassembling. Valve spool and body are available only as a matched set.

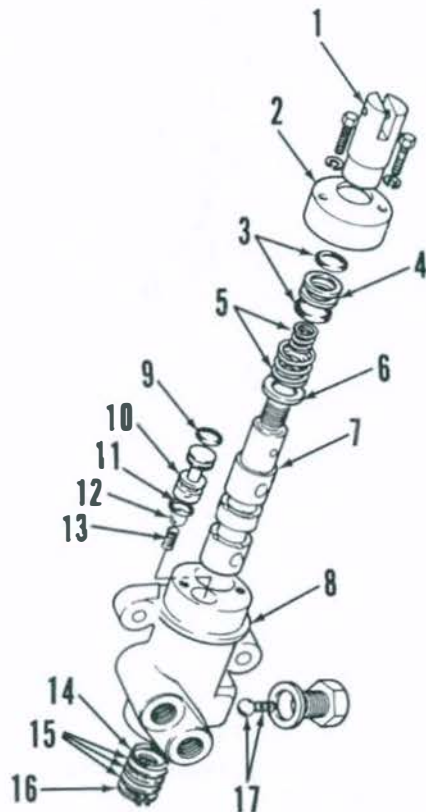

Fig. 19—Exploded view of steering control valve used on Models MF240 and MF250.

- |                |                                |
|----------------|--------------------------------|
| 1. Yoke        | 10. Bypass piston              |
| 2. Cover plate | 11. "O" ring                   |
| 3. "O" rings   | 12. Check ball                 |
| 4. Seal plug   | 13. Spring                     |
| 5. Springs     | 14. "O" rings                  |
| 6. Washer      | 15. Washers & felt seal        |
| 7. Valve spool | 16. Snap ring                  |
| 8. Valve body  | 17. Relief valve spring & ball |
| 9. "O" ring    |                                |

To reassemble valve, reverse the disassembly procedure. Lubricate all parts with oil during assembly.

Reinstall valve and adjust linkage as outlined in paragraph 15.

**STEERING CYLINDERS**

**Models MF240-MF250**

**17. R&R AND OVERHAUL.** Cylinders used on early models are retained by nuts on ball ends to each end. On later models, inner end of cylinder is retained by a pivot pin.

To disassemble steering cylinders, refer to appropriate Fig. 20 or 21 and proceed as follows: Remove oil from cylinder by working piston back and forth. Unscrew gland nut (13), then withdraw piston and rod assembly and the inner tube (3) from cylinder barrel (1). Unscrew piston (7) from rod (14), then remove remaining components from rod.

Inspect all parts for wear, scoring or damage and renew if necessary. Renew all seals and "O" rings.

To reassemble cylinder, reverse the disassembly procedure. Lubricate all parts with oil before assembling.

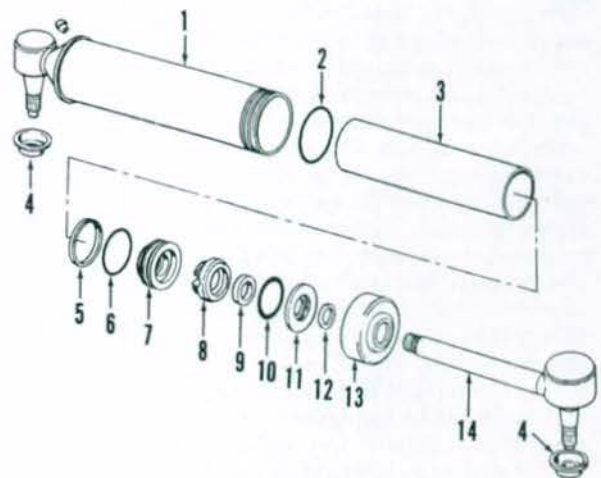

Fig. 20—Exploded view of early style power steering cylinder used on Models MF240 and MF250.

1. Cylinder barrel
2. "O" ring
3. Innertube
4. Dust cover
5. Piston seal
6. "O" ring
7. Piston
8. Oil seal
10. "O" ring
11. Washer
12. Scraper seal
13. Gland nut
14. Piston rod

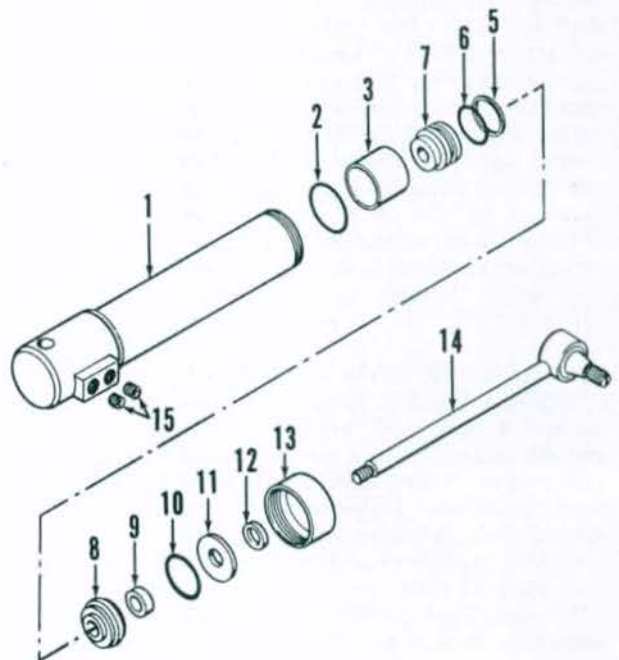

Fig. 21—Exploded view of late style power steering cylinder used on Models MF240 and MF250. Refer to Fig. 20 for legend except for orifice plugs (15).

# HYDROSTATIC STEERING SYSTEM

This section covers the steering system used on MF235 Orchard models and all MF245 models except Vineyard.

## LUBRICATION AND BLEEDING

### All Models So Equipped

18. The hydrostatic steering hand pump and steering cylinder assembly are lubricated by the operating fluid. Massey-Ferguson Permatran III Oil is recommended. The system is self bleeding, but steering should be cycled and reservoir refilled as often as necessary until level stops dropping.

## SYSTEM OPERATING PRESSURE AND RELIEF VALVE

### All Models So Equipped

19. Normal system relief valve pressure is approximately 8300 kPa (1200 psi) with engine operating at 2000 rpm. Refer to paragraph 7 for testing and adjusting procedures.

## STEERING CYLINDER

### All Models So Equipped

20. **OVERHAUL.** Two types of steering cylinders have been used. If two

Fig. 23—Exploded view of one type of steering cylinder used on Models MF235 and MF245 equipped with hydrostatic steering system. Refer to Fig. 22 for other type cylinder and legend.

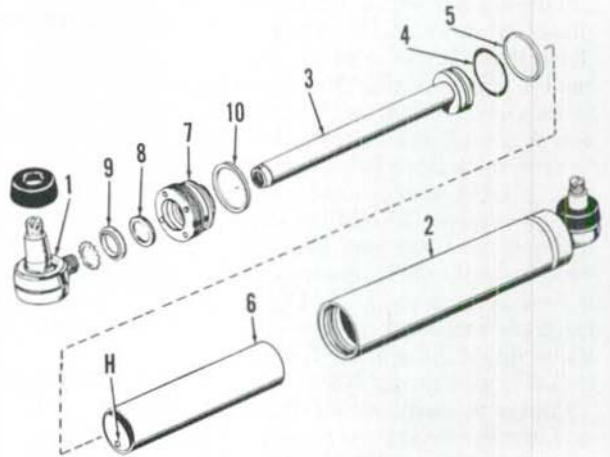

steering cylinders are used on the same tractor (Orchard models), both cylinders should be alike.

To disassemble the cylinder shown in Fig. 22 or 23, remove oil from cylinder by working piston back and forth. Remove rod end (1) and star washer, then unscrew cap (7). Renew all seals when assembling. Heat Teflon rings in warm oil to soften before installing. Install piston in inner tube (6) from end opposite hole (H—Fig. 23). Do not push piston and seal ring past the hole. Lip of scraper (9—Fig. 22 or 23) should be out. Lubricate all parts before assembling. Tighten cap (7) to approximately 400 N·m (300 ft.-lbs.) torque.

## HYDROSTATIC HAND PUMP

### All Models So Equipped

21. **REMOVE AND REINSTALL.** To remove the hydrostatic hand pump, first remove the battery and the steering wheel. Disconnect the oil pressure line at gage and tachometer cable at both ends, then remove the tachometer cable and cable housing. Mark all wires to facilitate reassembly, then disconnect all wires from instrument panel gages. Remove lights from panel gages and disconnect fuel shut-off from injection pump (diesel models). Remove the complete instrument panel with gages. Disconnect wires from starter switch and light switch, then unbolt and remove the rear hood assembly with starter and light switches installed. Disconnect linkage from both ends of the throttle cross shaft, then slide shaft from left side of tractor. Remove the complete air cleaner assembly and the battery platform. Clean the area thoroughly before disconnecting any power steering lines. Disconnect the four hydraulic lines and plug all openings to prevent entrance of dirt, then unbolt and remove the hydrostatic hand pump.

To reinstall, reverse the removal procedure. Be careful to connect wires to instruments correctly. Bleed the hydraulic system as outlined in paragraph 6 after all lines are connected. Be sure that system is not allowed to operate without fluid in reservoir.

### Orchard Models

22. **OVERHAUL.** MF235 and MF245 Orchard models are equipped with a Char-Lynn open center type hydrostatic hand pump. The rotary valve sleeve

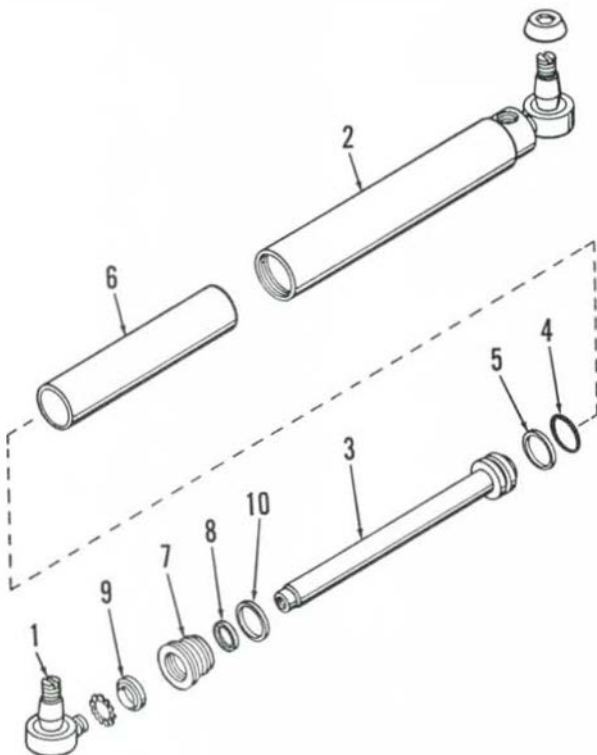

Fig. 22—Exploded view of one type of steering cylinder used on Models MF235 and MF245 equipped with hydrostatic steering system. Refer to Fig. 23 for other type cylinder.

1. Ball joint end
2. Cylinder barrel
3. Rod & piston
4. "O" ring
5. Seal ring
6. Inner tube
7. End cap
8. Seal
9. Scraper
10. Seal ring

spool (17—Fig. 24) and housing (18) are available as a matched set only.

To disassemble the removed unit, first remove cap screws (24) and withdraw end plate (23), gear set (21), spacer (20) and drive link (19) as a unit. Unbolt and remove upper housing (5) and input shaft (1) as a unit. Withdraw the control spool and sleeve (17) as a unit from bottom end of housing. Remove Teflon discs (11), then push pin (10) and centering springs (9) out of sleeve. Carefully slide spool (splined end first) from sleeve (Fig. 25). Insert a bent wire through port in valve body and push plug (12—Fig. 24) from body, then remove check valve seat (14) using an Allen wrench. Remove check ball (15) and spring (16).

Inspect centering springs (9) for cracks or distortion and renew if necessary. Inspect spacer plates (20 and 23) and gear set (21) for wear or scoring. Parts should be renewed if measurable wear exists. Inspect control spool and sleeve and housing bore for nicks, scoring or wear. If any part is damaged, renew steering pump assembly. Renew all "O" rings and seals.

When assembling the unit, tighten check valve seat (14) to a torque of 17 N·m (150 in.-lbs.). Assemble spool in sleeve making sure spool rotates smoothly in sleeve. Align spring slots in spool and sleeve, then insert centering springs (two sets of three each) so arched center sections are together as shown in Fig. 25A. Insert pin (10—Fig. 24) into spool and sleeve assembly and install a Teflon disc (11) at each end of pin.

Install assembled control spool unit from bottom of valve body using a twisting motion. Do not allow sleeve to move beyond flush with machined surface of metering end of valve body.

Install upper housing (5) with input shaft (1) over splined end of spool and onto valve body. Tighten retaining cap

screws evenly to 25 N·m (220 in.-lbs.) torque.

Be sure pin slot in drive shaft (Fig. 26) is aligned with a valley of inner rotor to ensure correct timing of control sleeve. If drive slot is improperly aligned, steering unit will operate in reverse or "kick back" when hydraulic pressure is applied. Assemble drive link (19—Fig. 24), spacer (20), gear set (21) and spacer (22) onto valve body. Note that spacer (22) should be flush with outer surface of gears if drive link is properly engaged with control spool pin. Install end cover (23) and tighten retaining cap screws evenly to 17 N·m (150 in.-lbs.) torque.

**MF245 Standard Models**

**23. OVERHAUL.** All MF245 models except Orchard are equipped with the hydrostatic hand pump shown exploded in Fig. 27. The valve spool (22) and body (25) are available only as a matched set.

To disassemble the removed steering control valve assembly, install a fitting in one of the four ports in valve body (25,

then clamp fitting in a vise so input shaft (17) is pointing downward. Remove cap screws (39) and end cover (38).

**NOTE:** Lapped surfaces of end cover (38), commutator set (33 and 34), manifold (32), stator-rotor set (31), spacer (29) and valve body (25) must be protected from scratching, burring or any other damage as sealing of these parts depends on their finish and flatness.

Remove seal retainer (35) and seal (36), then carefully remove washer (37), commutator set (33 and 34) and manifold (32). Grasp spacer (29) and lift off the spacer, drive link (30) and stator-rotor set (31) as an assembly. Separate spacer and drive link from stator-rotor set.

Remove unit from vise, then clamp fitting in vise so input shaft is pointing upward. Place a light mark on flange of upper cover (9) and valve body (25) for aid in reassembly. Unbolt upper cover from valve body, then grasp input shaft and remove input shaft, upper cover and valve spool assembly. Remove and discard seal ring (10). Slide upper cover assembly from input shaft and remove Teflon spacer (16). Remove shims (12) from cavity in upper cover or from face of thrust washer (14) and note number



Fig. 25—View of control spool end sleeve assembly. Teflon discs (11) cover outer ends of internal pin. Withdraw spool from sleeve in direction of arrow (A).

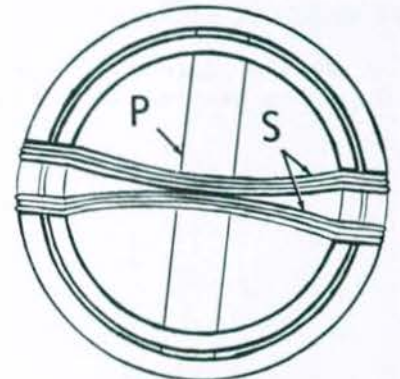

Fig. 25A—Schematic end view of steering control sleeve and spool showing correct assembly of centering springs (S) and drive pin (P).

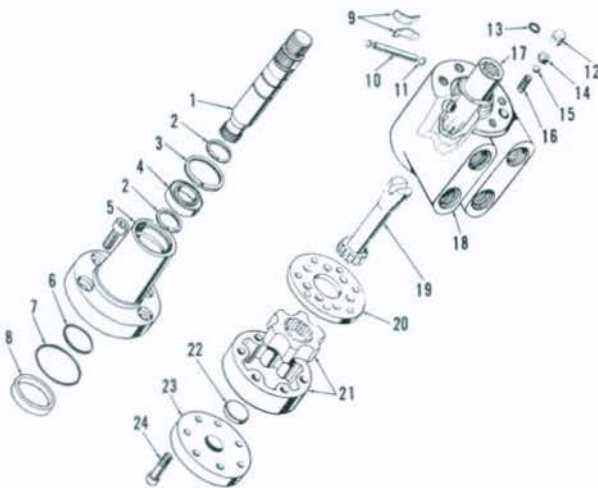

Fig. 24—Exploded view of Char-Lynn Orbitrol hydrostatic steering hand pump used on MF235 and MF245 Orchard models.

1. Input shaft
2. Snap rings
3. Snap ring
4. Bearing
5. Shaft housing
6. Quad ring
7. "O" ring
8. Bushing
9. Centering springs
10. Pin
11. Teflon disc
12. Plug
13. "O" ring
14. Ball seat
15. Check valve ball
16. Spring
17. Control spool & sleeve
18. Valve housing
19. Drive link
20. Spacer plate
21. Gear set
22. Spacer
23. End plate
24. Cup screw



Fig. 26—When properly assembled, slot in end of drive link must align with valley of inner gear as shown to provide correct valve timing.

of shims for aid in reassembly. Remove snap ring (4) and seal assembly (8).

Remove snap ring (13), thrust washers (14) and thrust bearing (15) from input shaft. Drive out pin (18) and withdraw torsion bar (21) and spacer (20). Place end of valve spool on top of bench and rotate input shaft until drive ring (19) falls free, then rotate input shaft clockwise until actuator ball (23) is disengaged from helical groove in input shaft. Withdraw input shaft and remove actuator ball. Do not remove actuator ball retaining spring (24) unless renewal is required.

Remove plug (28) and recirculating ball (26) from valve body. Thoroughly clean all parts in a suitable solvent, visually inspect parts and renew any showing excessive wear, scoring or other damage.

Using a micrometer, measure thickness of the commutator ring (33) and commutator (34). If commutator ring is 0.038 mm (0.0015 inch) or more thicker than commutator, renew the matched set.

Place the stator-rotor set (31) on the lapped surface of end cover (38). Make certain that vanes and vane springs are installed correctly in slots of the rotor.

**NOTE:** Arched back of springs must contact vanes.

Position lobe of rotor in valley of stator as shown at (V— Fig. 28). Center opposite lobe on crown of stator, then using two feeler gages, measure clearance (C) be-

tween rotor lobes and stator. If clearance is more than 0.15 mm (0.006 inch), renew stator-rotor assembly. Using a micrometer, measure thickness of stator and rotor. If stator is 0.05 mm (0.002 inch) or more thicker than rotor, renew the assembly. Stator, rotor, vanes and vane springs are available only as an assembly.

Before reassembling, wash all parts in clean solvent and air dry. All parts, unless otherwise indicated, are installed dry. Install recirculating ball (26—Fig. 27) and plug (28) with new "O" ring (27) in valve body and tighten plug to a torque of 14-19 N · m (10-14 ft.-lbs.). Clamp fitting (installed in valve body port) in a vise so top end of valve body is facing upward. Install thrust washer (14), thrust bearing (15), second thrust washer (14) and snap ring (13) on input shaft (17).

If actuator ball retaining spring (24) was removed, install new retaining spring. Place actuator ball (23) in its seat inside valve spool (22). Insert input shaft into valve spool engaging the helix and actuator ball with a counterclockwise motion. Use the midsection of torsion bar (21) as a gage between end of valve spool and thrust washer, then place the assembly in a vertical position with end of input shaft resting on a bench. Insert drive ring (19) into valve spool until drive ring is engaged on input shaft spline. Remove torsion bar gage.

Install spacer (20) on torsion bar and insert the assembly into valve spool. Align cross holes in torsion bar and in-

put shaft and install pin (18). Pin must be pressed into shaft until end of pin is about 0.8 mm (1/32 inch) below flush. Place spacer (16) over spool and install spool assembly into valve body.

Position original shims (12) on thrust washer (14), lubricate new seal ring (10), place seal ring in upper cover (9) and install upper cover assembly. Align the match marks on cover flange and valve body and install cap screws finger tight. Tighten a worm drive type hose clamp around cover flange and valve body to align the outer diameters, then tighten cap screws to a torque of 24-30 N · m (18-22 ft.-lbs.).

**NOTE:** If either input shaft (17) or upper cover (9) or both have been renewed, the following procedure for shimming must be used. With upper cover installed (with original shims) as outlined above, invert unit in a vise so input shaft is pointing downward. Grasp input shaft, pull downward and prevent it from rotating. Engage drive link (30) splines in valve spool and rotate drive link until end of spool is flush with end of valve body. Remove drive link and check alignment of drive link slot to torsion bar pin. Install drive link until its slot engages torsion bar pin. Check relationship of spool end to body end. If end of spool is within 0.0635 mm (0.0025 inch) of being flush with end of body, no additional shimming is required. If not within 0.0635 mm (0.0025 inch) of being flush, remove cover and add or remove shims (12) as necessary. Reinstall cover and recheck spool to valve body position.

With drive link installed, place spacer plate (29) on valve body with plain side up. Install stator-rotor set over drive link splines and align cap screw holes. Make certain vanes and vane springs are prop-

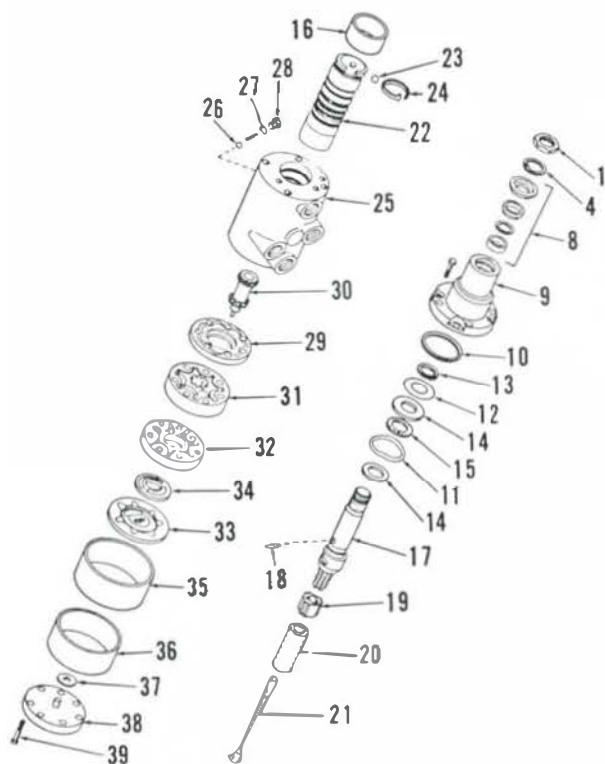

Fig. 27—Exploded view of steering control valve assembly (hydrostatic hand pump) used on standard MF245 models.

1. Nut
4. Snap ring
8. Seal assy.
9. Cover (upper)
10. Seal
11. Washer
12. Shims
13. Snap ring
14. Thrust washers
15. Thrust bearing
16. Teflon spacer
17. Input shaft
18. Pin
19. Drive ring
20. Spacer
21. Torsion bar
22. Valve spool
23. Actuator ball
24. Retaining spring
25. Valve body
26. Recirculating ball
27. "O" ring
28. Plug
29. Spacer plate
30. Drive link
31. Stator-Rotor set
32. Manifold
33. Commutator ring
34. Commutator
35. Seal retainer
36. Seal
37. Washer
38. End cover
39. Cap screws

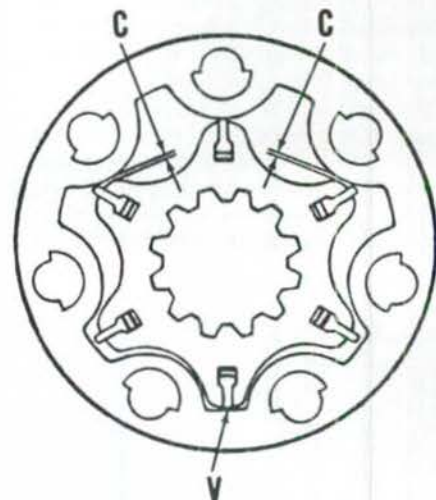

Fig. 28—With rotor positioned in stator as shown, clearances (C) must not exceed 0.15 mm (0.006 inch). Refer to text.



erly installed. Install manifold (32) with circular slotted side up and align cap screw holes with stator, spacer and valve body. Install commutator ring (33) with slotted side up, then install commutator (34) over drive link end making certain that link end is engaged in the smallest elongated hole in commutator. Install seal (36) and retainer (35). Apply a few drops of hydraulic fluid on commutator. Use a small amount of grease to stick washer (37) in position over pin on end cover (38). Install end cover making sure that pin engages center hole in commutator. Align holes and install cap screws (39). Alternately and progressively tighten cap screws while rotating input shaft. Final tightening should be 24-30 N·m (18-22 ft.-lbs.) torque.

Relocate the unit in vise so input shaft is up. Lubricate new seal (8) and carefully work seal over shaft and into bore with lip toward inside. Install snap ring (4) with rounded edge inward.

Remove unit from vise and remove fitting from port. Turn unit on its side with hose ports upward. Pour clean hydraulic fluid into inlet port, rotate input shaft until fluid appears at outlet port, then plug all ports until installation.

### POWER STEERING PUMP

#### All Models So Equipped

24. The power steering hydraulic pump used on models equipped with hydrostatic power steering is the same as pumps used on tractors equipped with power assist steering systems. The pump used on tractors with diesel engine is shown in Fig. 10 and pump used on tractors with gasoline engine is shown in Fig. 11. Refer to paragraph 8 for removal procedure and to appropriate paragraph 9 or 10 for overhaul procedure.

Lubricate clutch shaft splines with lithium base grease before connecting engine to transmission. Install in reverse of removal procedure. Fill and bleed power steering system as outlined in paragraph 6.

### CYLINDER HEAD

#### All Gasoline Models

26. REMOVE AND REINSTALL. Drain cooling system and remove hood. Shut off fuel, disconnect gage wire and remove fuel tank. Disconnect upper radiator hose from thermostat housing and wire from temperature gage sending unit. Disconnect air cleaner hose, fuel line, choke and throttle rod from carburetor, then remove the carburetor. Disconnect exhaust pipe on low exhaust models or remove muffler on vertical exhaust models. Remove intake and exhaust manifold, radiator brace, rocker arm cover and the rocker shaft assembly.

**CAUTION:** Don't let push rods fall down into the cylinder block while removing the rocker shaft assembly.

## GASOLINE ENGINE AND COMPONENTS

All gasoline models are equipped with Continental Z-145, four cylinder engine.

### R&R ENGINE ASSEMBLY

#### All Gasoline Models

25. First drain cooling system and, if engine is to be disassembled, drain oil pan. Remove front grille panels and disconnect battery cables. Remove fuel tank cap, radiator cap and hood. Disconnect headlight wires and pull wiring free. Disconnect both radiator hoses, radiator brace and, on models so equipped, hydraulic oil lines and front mounted pump. Support tractor at front of transmission. Position wedge blocks between front axle and axle support. Support the front end assembly at front and rear. Disconnect drag links and radius rods at rear of models so equipped. On models with drag links, attach drag links to axle so wheels will be straight ahead and will not turn. On

models with power steering, disconnect lines and cover all hydraulic steering openings. Unbolt the front assembly and carefully roll away from tractor. Shut fuel off at tank, unclip headlight wires from side of tank, disconnect wire from fuel gage sending unit, detach fuel line from shut off valve, then remove the fuel tank. Disconnect battery ground strap and wires from alternator, starter motor, ignition coil and water temperature gage sending unit. Detach tachometer drive cable and housing, air cleaner hose, breather tube, throttle rod, choke cable, engine oil pressure line and muffler (or exhaust pipe). Disconnect the power steering lines along left side of cylinder head on models so equipped. Attach a hoist to engine, be sure that all wires, lines, hoses and rods are out of the way, then unbolt and separate engine from transmission.

**NOTE:** Separating and joining engine to transmission is more easily and more safely accomplished using guide studs.

Lift all eight push rods out, remove spark plugs, then loosen cylinder head retaining screws in reverse of sequence shown in Fig. 29. Remove the cylinder head screws and lift head off.

Inspect cylinder for warpage, cracks or other damage. Original thickness of cylinder head is 86.52 mm (3.406 inches). Cylinder head may be machined up to 0.76 mm (0.030 inch) to obtain a flat gasket surface.

Install by reversing the following: Cylinder head gasket is marked "BOTTOM" which should be toward block. New gasket should need no sealer; however, if difficulties with gasket sealing are encountered, coat both sides of gasket with heat resisting aluminum paint or appropriate sealer immediately before assembling. Tighten the cylinder head retaining cap screws in sequence shown in Fig. 29. Tighten the screws evenly, increasing torque in 15-20 N·m (10-15 ft.-lbs.) increments until the final torque of 95-102 N·m (70-75 ft.-lbs.) is obtained. Be careful not to permit push rods to fall into block while installing rocker arm assembly. Make sure that caps are in position on all valve stems.

Tighten rocker arm shaft support screws to 27-34 N·m (20-25 ft.-lbs.) torque. Adjust valve clearance cold to 0.33 mm (0.013 inch) for intake and 0.38 mm (0.015 inch) for exhaust. Tighten intake and exhaust manifold screws to 34-40 N·m (25-30 ft.-lbs.) and spark plugs to 43-52 N·m (32-38 ft.-lbs.) torque.

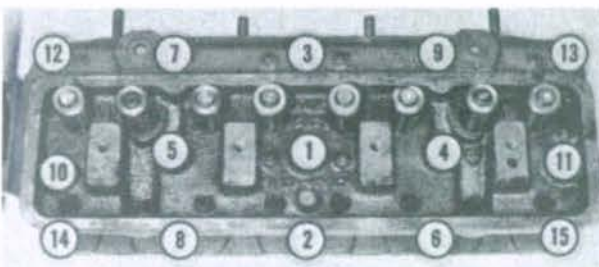

Fig. 29—Cylinder head retaining cap screws should be loosened in reverse of tightening sequence shown. Tighten screws in 15-20 N·m (10-15 ft.-lbs.) increments in order shown until final torque of 95-102 N·m (70-75 ft.-lbs.) is reached.

VALVES AND SEATS

Retorque cylinder head retaining cap screws to 95-102 N · m (70-75 ft.-lbs.) and readjust valve clearance to "Hot" setting after engine has been started and reaches operating clearance. Refer to following paragraph for valve clearance adjustment procedure.

**27. VALVE CLEARANCE ADJUSTMENT.** The recommended valve clearance with engine cold is 0.33 mm (0.013 inch) for intake valves and 0.38 mm (0.015 inch) for exhaust valves. Recommended clearance with engine hot (normal operating temperature) is 0.28 mm (0.011 inch) for intake valves and 0.33 mm (0.013 inch) for exhaust valves. Valve clearance can be adjusted as follows:

Remove timing plug from left side of cylinder block and turn crankshaft until top dead center timing mark (DC—Fig. 31) is aligned with timing notch in housing as shown. Check rocker arms for No. 1 and No. 4 cylinders. If rocker arms on No. 4 cylinder are tight, No. 1 cylinder is on compression stroke and valves indicated in Fig. 32 can be adjusted. If rocker arms on No. 1 cylinder are tight, No. 4 cylinder is on compression stroke and valves indicated in Fig. 33 can be adjusted. After adjusting the four valves indicated in appropriate Fig. 32 or 33, rotate crankshaft one complete turn and adjust clearance of the remaining four valves.

All Gasoline Models

28. Intake valves seat directly in cylinder head and valve stems are equipped with neoprene oil seals. Positive type valve stem seal kit is available; however, valve guides must be machined to accept seal. Exhaust valves have renewable seat inserts and stems are equipped with positive type valve rotators (Rotocaps).

Replacement exhaust valve seat inserts are provided in 0.25 mm (0.010 inch) oversize only. When renewing the seal inserts, remachine cylinder head so insert counterbore measures 31.991-32.017 mm (1.2595-1.2605 inches) to provide recommended 0.08-0.13

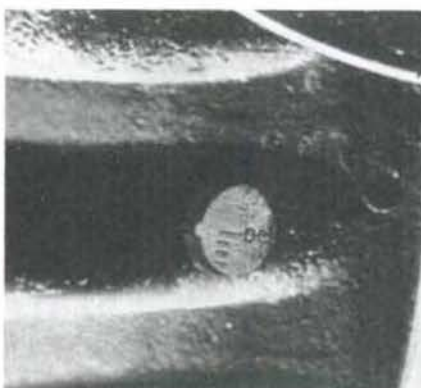

Fig. 31—Align the "DC" flywheel mark with notch as shown when adjusting valve clearance as described in paragraph 27.

mm (0.003-0.005 inch) interference fit. Intake valve face and seat angle is 30°. Exhaust valves have a face angle of 44° and seat angle of 45° to provide the recommended 1° interference angle. Desired seat width is 1.6-2.4 mm (1/16-3/32 inch) for all valves. Seats can be narrowed using 15° and 75° stones.

VALVE GUIDES

All Gasoline Models

29. The presized intake and exhaust valve guides are interchangeable. Inside diameter of new guides is 8.019-8.057 mm (0.3157-0.3172 inch). Inner bore of new guides has a fine, spiral groove or rifling which gives guide an unfinished appearance upon inspection, but guide must not be reamed. To renew the guides, press old guides downward out of cylinder head using a piloted mandrel. Press new guide in from the top until distance (A—Fig. 34) measured from rocker arm cover gasket surface to top of guide is 2.38 mm (3/32 inch).

Valve stem diameters and clearance limits in guides are as follows:

Valve Stem Diameter—

Intake . . . . .	7.978-7.998 mm
	(0.3141-0.3149 in.)
Exhaust . . . . .	7.935-7.955 mm
	(0.3124-0.3132 in.)

Clearance—

Intake . . . . .	0.021-0.079 mm
	(0.0008-0.0031 in.)
Exhaust . . . . .	0.064-0.122 mm
	(0.0025-0.0048 in.)

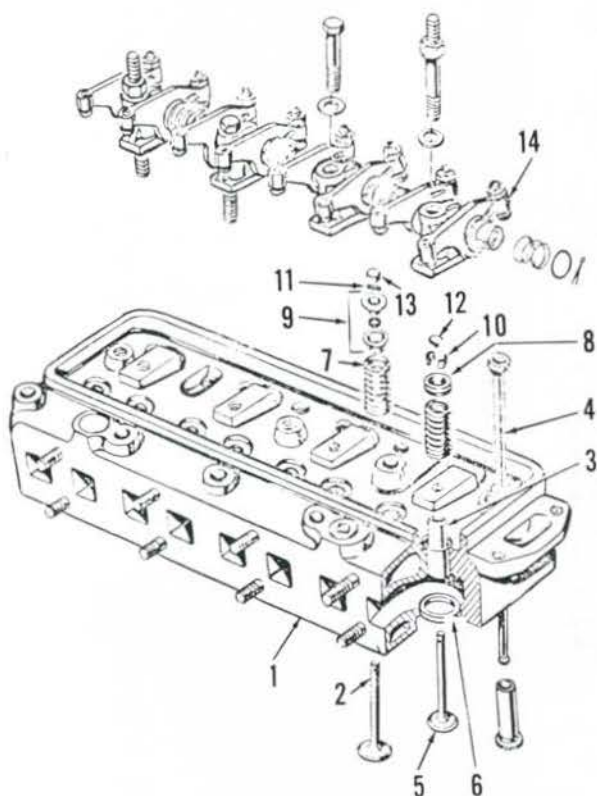

Fig. 30—Exploded view of cylinder head. Rocker arms should be assembled with offset as shown in Fig. 36.

1. Cylinder head
2. Intake valve
3. Valve guide
4. Push rod
5. Exhaust valve
6. Exhaust valve seat
7. Valve spring
8. Exhaust valve rotator cap
9. Intake valve seal & cap
10. Exhaust valve keepers
11. Intake valve keeper
12. Exhaust valve cap
13. Intake valve cap

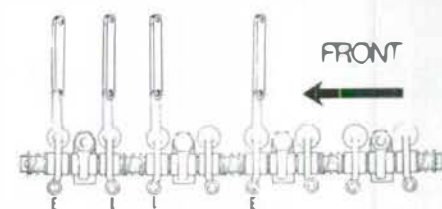

Fig. 32—With "DC" timing mark aligned as shown in Fig. 31 and No. 1 piston on compression stroke, adjust the indicated valves. Turn crankshaft one complete revolution until timing marks are again aligned as shown in Fig. 31, refer to Fig. 33 and adjust remainder of valves.

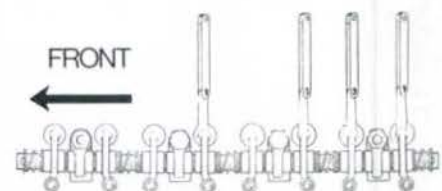

Fig. 33—With "DC" timing mark aligned as shown in Fig. 31 and No. 4 piston on compression stroke, adjust the indicated valves.

VALVE STEMS

All Gasoline Models

30. Intake and exhaust valve springs are interchangeable. Springs should be installed with damper end (closely wound coils) towards cylinder head. Renew any spring that is rusted, discolored, distorted or does not test within 10 percent of the following test specifications: Free length should be approximately 52.39 mm (2-1/16 inches). Spring pressure should be 209-235 N (47-53 pounds) when compressed to 43.25 mm (1-45/64 inches) and 427-462 N (96-104 pounds) when compressed to 36.12 mm (1-27/16 inches).

VALVE ROTATORS

All Gasoline Models

31. Normal servicing of the positive type exhaust valve rotators ("Rotocaps") consists of renewing the units. It is important, however, to observe the valve action after valve is assembled. The valve rotator can be considered satisfactory if the valve turns a slight amount each time the valve opens.

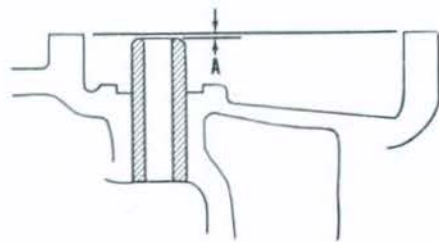
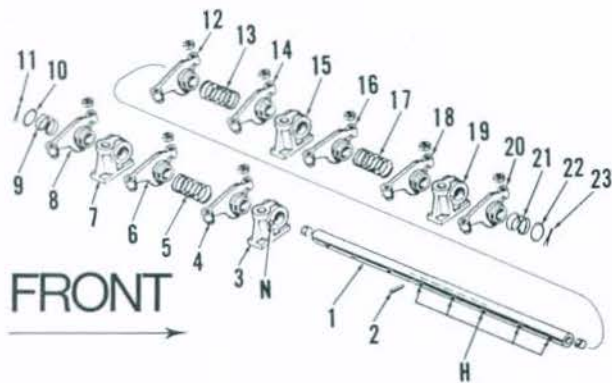

Fig. 34—When renewing valve guides, distance (A) from top of guide to rocker cover gasket surface should be 2.38 mm (3/32 inch).



- 1. Shaft
- 2. Pin
- 3. Bracket
- 4. Rocker arm "7R"
- 5. Spring
- 6. Rocker arm "8L"
- 7. Bracket
- 8. Rocker arm "7R"
- 9. Short spring

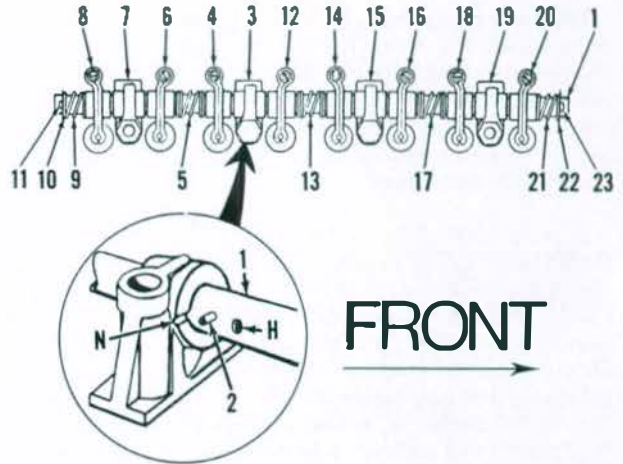

Fig. 36—Drawings showing the offset of rocker arms and installation of pin (2) in notch (N) of the third bracket (3). Refer to Fig. 35 for legend.

FRONT

CAM FOLLOWERS

All Gasoline Models

32. The mushroom type cam followers (tappets) operate directly in machined bores of the cylinder block and are available only in standard size of 14.262-14.275 mm (0.5615-0.5620 inch). Clearance in bore should be 0.013-0.046 mm (0.0005-0.0018 inch).

The cam followers can be removed from below after removing camshaft as outlined in paragraph 36. Cam followers should be reinstalled in their original positions if being reused. Cam followers should be renewed if camshaft is renewed.

notch (N) in front face of the third support bracket (3). Begin assembly by installing pin in notch of bracket as shown in Fig. 36. Install one rocker arm (4—Fig. 35) stamped "7R", spring (5), rocker arm (6) stamped "8L", another bracket (7), another rocker arm (8) stamped "7R", short spring (9), washer (10) and cotter pin (11) to the short end of shaft. Install remaining parts to longer end of shaft as shown in Figs 35 and 36. Rocker arms (4,8,14 and 18) are alike and stamped "7R". Rocker arms (6,12,16 and 20) are alike and stamped "8L". Springs (5,13 and 17) are identical as are support brackets (3,7,15 and 19). Short spring (9 or 21), washer (10 or 22) and cotter key (11 or 23) are used at each end.

ROCKER ARMS

All Gasoline Models

33. Rocker arm bushings are not renewable. Renew rocker arms and/or shaft if clearance between shaft and bushing is not within limits of 0.013-0.046 mm (0.0005-0.0018 inch). Rocker shaft is positioned by locating pin (1—Fig. 35) in shaft (1) which fits in a

TIMING GEAR COVER

All Gasoline Models

34. REMOVE AND REINSTALL. First separate the front system from the engine as follows: Drain cooling system, remove front grille panels and disconnect battery cables. Remove fuel tank cap, radiator cap and hood. Disconnect headlight wires and pull wiring free. Disconnect both radiator hoses, radiator brace and, on models so equipped, hydraulic oil lines and front mounted pump. Support tractor at front of transmission. Position wedge blocks between front axle and axle support. Support the front end assembly at front and rear. Disconnect drag links and radius rods at rear of models so equipped. On models with drag links, attach drag links to axle so wheels will be straight ahead and will not turn. On models with power steering, disconnect lines, remove the power steering pump and cover all hydraulic steering openings. On all models, unbolt the front assembly and carefully roll away from tractor.

Remove the fan belt and crankshaft pulley. Detach the spring and rod from

Fig. 35—Exploded view of rocker arm assembly. Oil holes (H) must be toward valve side and rocker arms must be offset as shown in Fig. 36. All brackets have notch (N), but pin (2) engages notch in third bracket (3).

- 10. Washer
- 11. Cotter pin
- 12. Rocker arm "8L"
- 13. Spring
- 14. Rocker arm "7R"
- 15. Bracket
- 16. Rocker arm "8L"
- 17. Spring
- 18. Rocker arm "7R"
- 19. Bracket
- 20. Rocker arm "8L"
- 21. Short spring
- 22. Washer
- 23. Cotter pin

the governor control lever. Unbolt the timing gear cover from engine block and oil pan, then carefully pull cover forward off dowels.

The crankshaft front oil seal can be renewed at this time. Press seal out, do not pry, to prevent damage to cover. Press new seal into position from inside with lip toward inside. The inside edge of seal should be flush with rear of seal bore in cover.

Install cover by reversing removal procedure. Be sure that driving lug (L—Fig. 37) on governor cup is at 6 o'clock position before installing cover. Trim the gasket between cylinder block and cover until ends are flush with cylinder block. Sealing between the timing gear cover and oil pan is more easily accomplished by installing oil pan with new gasket after cover is installed. Tighten the timing gear cover to engine block screws to 34.40 N·m (25-30 ft.-lbs.) torque, and the oil pan to timing gear cover screws to 16-22 N·m (12-16 ft.-lbs.) torque.

**TIMING GEARS**

**All Gasoline Models**

35. Timing gears can be renewed after removing timing gear cover as outlined in paragraph 34. Withdraw governor race and shaft assembly from camshaft. Remove nut retaining camshaft gear to camshaft and lift off the governor ball driver assembly. Remove timing gears using suitable puller. Be careful not to damage governor shaft bore in camshaft when pulling camshaft gear.

Recommended backlash between crankshaft and camshaft gears is 0.03-0.05 mm (0.001-0.002 inch). Gears are available in standard size, undersizes and oversizes. Gears are marked "S" (standard), "U" (undersize) or "O" (oversize) and the number "1" or "2" denoting 0.001-0.002 inch oversize or undersize.

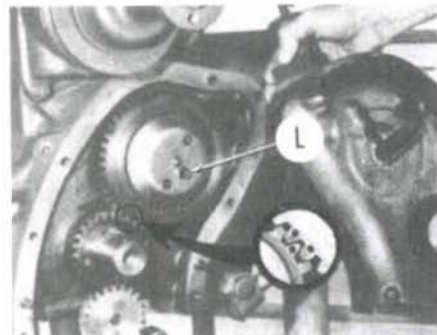

Fig. 37—View of timing marks on camshaft gear and crankshaft gear aligned. Lug (L) should be at 6 o'clock position before cover is installed.

Correct backlash between crankshaft and oil pump gears is 0.089-0.107 mm (0.0035-0.0042 inch).

During installation, mesh the single punch marked tooth on crankshaft gear with the double punch marked tooth space on camshaft gear (Fig. 37). Heating camshaft gear in oil or in an oven to approximately 149°C (300°F) will facilitate gear installation. Remove oil pan and support camshaft in a forward position while gear is being installed to prevent loosening and leakage of camshaft rear plug.

Tighten the camshaft gear retaining nut to a torque of 95-108 N·m (70-80 ft.-lbs.).

**CAMSHAFT**

**All Gasoline Models**

36. To remove the camshaft, first remove camshaft timing gear as outlined in paragraph 35. Remove fuel tank, rocker arm cover, rocker arms and shaft assembly and push rods. Remove the ignition distributor and oil pan. Block up or support the cam followers. Remove the

screws securing camshaft thrust plate (18—Fig. 38) to engine block and withdraw camshaft from front of engine.

All camshaft journals ride directly in machined bores in the cylinder block. Normal diametral clearance is 0.064-0.114 mm (0.0025-0.0045 inch). Renew camshaft and/or cylinder block if clearance exceeds 0.18 mm (0.007 inch). Camshaft journal diameter is 45.92-45.95 mm (1.808-1.809 inches) for front journal, 44.34-44.36 mm (1.7455-1.7465 inches) for center journal and 42.75-42.77 mm (1.683-1.684 inches) for rear journal. Camshaft end play is controlled by thrust plate (18) and is normally within a range of 0.076-0.178 mm (0.003-0.007 inch). Thickness of thrust plate when new is 3.735-3.785 mm (0.147-0.149 inch).

**ROD AND PISTON UNITS**

**All Gasoline Models**

37. Connecting rod and piston units are moved from above after removing cylinder head and oil pan. Correlation marks on rod and cap should be in-

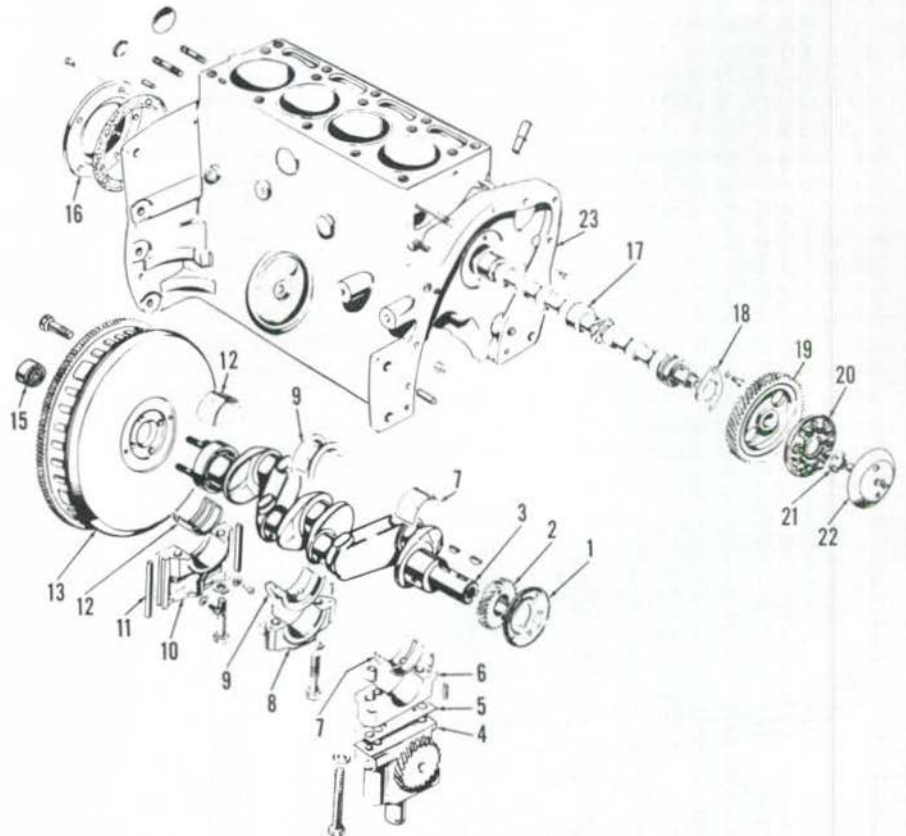

Fig. 38—Exploded view of cylinder block and associated parts.

- |                     |                     |                            |                          |
|---------------------|---------------------|----------------------------|--------------------------|
| 1. Oil slinger      | 7. Bearing liners   | 12. Bearing liners         | 18. Thrust plate         |
| 2. Crankshaft gear  | 8. Main bearing cap | 13. Flywheel               | 19. Camshaft gear        |
| 3. Crankshaft       | 9. Bearing liners   | 14. Pilot bearing          | 20. Governor weight unit |
| 4. Oil pump         | 10. Bearing cap     | 15. Rear oil seal retainer | 21. Nut                  |
| 5. Shim pack        | 11. Seal strips     | 16. Camshaft               | 22. Governor cup         |
| 6. Main bearing cap |                     |                            | 23. Cylinder block       |

stalled facing camshaft side of engine. Replacement rods are not marked but should be stamped with cylinder number before installation, on side of rod opposite the oil spray hole. Piston skirts are notched at lower edge; notch is to be installed to front of engine when unit is reassembled.

Tighten the connecting rod cap screws to a torque of 54-61 N · m (40-45 ft.-lbs.).

**PISTONS, SLEEVES AND RINGS**

**All Gasoline Models**

38. Pistons are available in standard size only, and are available only in a kit which includes piston, pin, rings and sleeve for one cylinder. Piston is cam ground.

If piston and/or sleeve are scored, if piston ring grooves or pin bore are worn or damaged, or if cylinder wall taper exceeds 0.20 mm (0.008 inch), renew piston and sleeve assembly.

Piston ring kits are available separately. Kits are marked for correct piston ring installation. Refer also to Fig. 39 for correct installation of rings.

Recommended piston ring end gap is 0.25-0.50 mm (0.010-0.020 inch) for all rings. Recommended side clearance in ring groove is 0.09-0.13 mm (0.0035-0.0050 inch) for top ring; 0.09-0.14 mm (0.0035-0.0055 inch) for second and third compression rings. Renew piston and sleeve assembly if side clearance of top ring exceeds 0.19 mm (0.0075 inch), or 0.20 mm (0.008 inch) for second or third compression rings.

Refer to Fig. 39 for installation of piston rings in grooves. The piston rings shown at (P) are for use in new sleeves, and rings (S) are for service in worn sleeves. To install rings (P) for new sleeves observe the following: The top ring is chrome plated, taper faced and may have inside diameter beveled. The

Fig. 40—Notches (N) in bottom of sleeves are for connecting rod clearance and should be at right angles to crankshaft as shown.

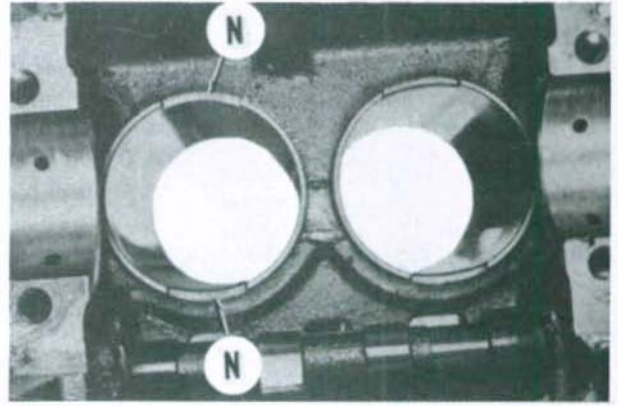

side of ring marked by dot or by bevel cut away should be toward top of piston. The second and third compression rings are taper faced and should be installed with side marked by dot toward top. Install oil ring expander in groove first, then install rails with gaps 50 mm (2 inches) from the gap in expander. Gap in one rail should be to left, other to right of gap in expander.

To install rings (S) for use in used cylinder sleeves, observe the following: The chrome plated top ring is taper faced. Install top ring with dot or beveled inside diameter toward top of piston. The second compression ring should be installed with beveled inside diameter or dot toward top. The third compression ring should have expander behind ring and the relief cut into outside diameter of ring should be down. The expander for the bottom oil control ring should be installed first, followed by the two rails. One rail should have end tap 50 mm (2 inches) to left of expander ends, the other rail should have end gap 50 mm (2 inches) to right.

The cylinder sleeves have notched reliefs at bottom for connecting rod clearance. The relief notches should be at right angles to crankshaft centerline as shown in Fig. 40.

Use a suitable puller to remove the wet type cylinder sleeves. Clean all surfaces of cylinder block which contact sleeve or sleeve seals.

Install sleeve into cylinder block bore before installing any seal rings to check for sleeve standout (Fig. 41). Select the necessary thickness of shims to provide 0.03-0.10 mm (0.001-0.004 inch) standout. Measure distance using a straightedge and feeler gage and be sure that sleeve is fully seated without nicks, burrs or foreign material preventing complete installation. Excessive or insufficient standout will both cause water leakage.

After sleeve standout has been checked, install sealing rings at bottom of sleeves. Make sure that seal rings are not twisted, then lubricate seals with petroleum jelly. Press sleeves into place being careful not to damage or lose shims. Notches (N—Fig. 40) should be perpendicular to crankshaft as shown.

**PISTON PINS**

**All Gasoline Models**

39. The full floating piston pins are retained in piston bosses by snap rings. Piston pins are available in standard size and 0.08 and 0.13 mm (0.003-0.005 inch) oversizes. Recommended clearance for piston pin in both the connecting rod and piston is 0.005-0.015 mm (0.0002-0.0006 inch). Standard piston pin diameter is 21.821-21.826 mm (0.8591-0.8593 inch). Hone new bushings to 21.831-21.836 mm (0.8595-0.8597 inch) after installation in connecting rod.

**CONNECTING RODS AND BEARINGS**

**All Gasoline Models**

40. Connecting rod bearings are of the precision type, renewable from below after removing oil pan. When installing new bearing shells, make sure that the projection engages the milled slot in rod

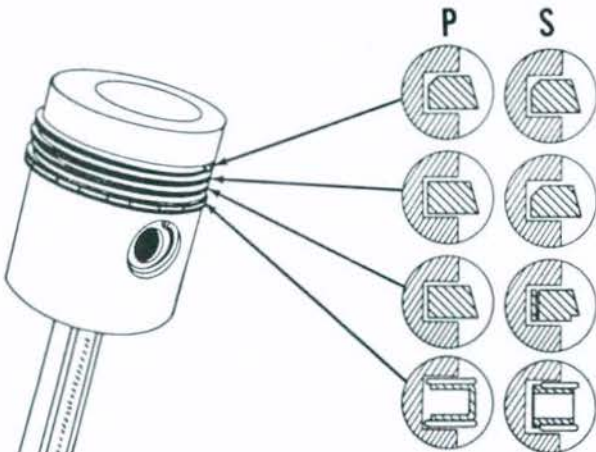

Fig. 39—Drawing showing cross-section of rings showing correct installation. Production rings (P) are used with new sleeves and service rings (S) are installed in sleeves which have been used. If ring is marked with dot, the dot should be toward top.

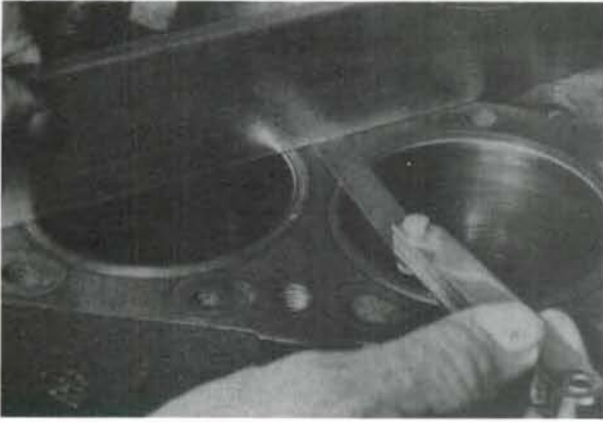

Fig. 41—Use a straightedge and feeler gage to measure cylinder sleeve endout.

and cap and that rod and cap correlation marks are in register. Replacement rods are not marked and should be stamped with cylinder number on side away from oil spray hole. Correlation marks should be on camshaft side of block when rods are installed. Bearings are available in undersizes of 0.05, 0.25 and 0.50 mm (0.002, 0.010 and 0.020 inch) as well as standard. Specifications are as follows:

<b>Crankpin</b>	
Diameter . . . . .	49.187-49.213 mm (1.9365-1.9375 in.)
Bearing Clearance . . .	0.015-0.079 mm (0.0006-0.0031 in.)
Wear Limit . . . . .	0.105 mm (0.004 in.)
Rod Side Clearance . . .	0.13-0.28 mm (0.005-0.011 in.)
Rod Bolt Tbrque . . . . .	54-61 N · m (40-45 ft.-lbs.)

**CRANKSHAFT AND BEARINGS**

**All Gasoline Models**

41. The crankshaft is supported in three precision insert type main bearings. The rear main bearing cap (10—Fig. 38) contains sealing strips (11) on each side of cap in addition to rear seal (16). Bearing inserts are available in undersizes of 0.05, 0.25 and 0.50 mm (0.002, 0.010 and 0.020 inch) as well as standard size. Normal crankshaft end play of 0.10-0.20 mm (0.004-0.008 inch) is controlled by the flanged center main bearing inserts (9).

To remove crankshaft, it is necessary to remove engine, clutch, flywheel, rear oil seal, timing gear cover, oil pan, oil pump main bearing and connecting rod caps.

Renew or regrind crankshaft if either main journals or crankpins are worn more than 0.025 mm (0.001 inch), are tapered more than 0.025 mm (0.001

inch), or are out-of-round more than 0.038 mm (0.0015 inch). Renew or straighten crankshaft if runout (total indicator reading) exceeds 0.076 mm (0.003 inch), checked at center main journal.

Specifications are as follows:

<b>Main Journal Diameter—</b>	
Standard . . . . .	57.125-57.150 mm (2.249-2.250 in.)
<b>Main Bearing</b>	
Clearance . . . . .	0.013-0.081 mm (0.0005-0.0032 in.)
Wear Limit . . . . .	0.107 mm (0.0042 in.)
Main Cap Torque . . . . .	115-129 N · m (85-95 ft.-lbs.)

<b>Crankpin Diameter—</b>	
Standard . . . . .	49.187-49.213 mm (1.9365-1.9375 in.)
<b>Rod Bearing</b>	
Clearance . . . . .	0.015-0.079 mm (0.0006-0.0031 in.)
Wear Limit . . . . .	0.105 mm (0.0041 in.)
Rod Cap Torque . . . . .	54-61 N · m (40-45 ft.-lbs.)
Flywheel Torque . . . . .	95-102 N · m (70-75 ft.-lbs.)

**CRANKSHAFT REAR OIL SEAL**

**All Gasoline Models**

42. The crankshaft rear oil seal (16—Fig. 38) is contained in a one-piece retainer and serviced only as an assembly. To renew the seal, first separate engine from transmission case as outlined in paragraph 112 and remove the flywheel. Remove the oil pan and the two cap screws securing rear seal retainer to main bearing cap; remove the three remaining cap screws and lift off the oil seal and retainer unit.

Apply a light coating of oil to seal lip, and apply gasket sealer to mounting gasket. Position seal retainer with the two threaded holes down. Reinstall cap screws and tighten evenly to a torque of 11-14 N · m (8-10 ft.-lbs.). Complete the assembly by reversing the disassembly procedure.

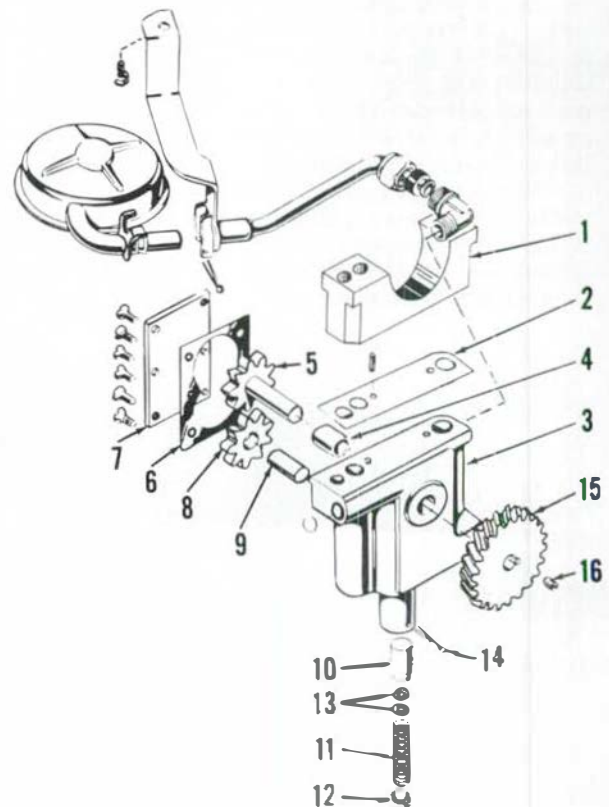

Fig. 42—Exploded view of engine oil pump and associated parts used on Continental gasoline engine.

1. Main bearing cap
2. Shim pack
3. Pump body
4. Bushing
5. Driven gear
6. Cawket
7. Cover
8. Idler gear
9. Shaft
10. Relief valve plunger
11. Spring
12. Spring seat
13. Adjusting shims
14. Cotter pin
15. Drive gear
16. Retaining screw

FLYWHEEL

All Gasoline Models

43. To remove the flywheel, separate engine from transmission case as outlined in paragraph 112 and remove the clutch. The starter ring gear can be renewed after removing the flywheel. To install a new ring gear, heat gear evenly to approximately 232°C (405°F) and install on flywheel with beveled edge of teeth facing front of engine.

One flywheel mounting stud is off center so flywheel can only be installed in the correct position. Tighten the flywheel retaining screws to a torque of 95-102 N·m (70-75 ft.-lbs.).

OIL PUMP

All Gasoline Models

44. The gear type oil pump is mounted on the bottom of front main bearing cap and is gear driven from crankshaft timing gear. Pump is accessible after oil pan is removed. Shims (2—Fig. 42) control the backlash of oil pump drive gear (15). Recommended backlash is 0.089-0.107 mm (0.0035-0.0042 inch). If backlash is not as specified, vary the thickness of shim pack (2). Be sure that main cap is tightened to recommended torque of 115-129 N·m (85-95 ft.lbs.) when checking backlash.

Check pump internal gears (5 and 8) for backlash, which should be 0.03-0.13 mm (0.001-0.005 inch). End play of gears with a 0.18 mm (0.007 inch) thick gasket (6) installed, should be 0.05-0.10 mm (0.002-0.004 inch). Recommended diametral clearance between gears and pump body is 0.08-0.10 mm (0.003-0.004 inch). If clearance exceeds 0.13 mm (0.005 inch), renew gears and/or body.

When installing pump cover (7), tighten retaining screws to 11-14 N·m (8-10 ft.-lbs.). Refer to paragraph 45 for information on pressure relief valve.

Fig. 44—Exploded view of typical carburetor. Parts shown in squares are major differences for smaller carburetor used on MF230 models.

1. Throttle plate
2. Throttle shaft
3. Idle speed screw
4. Throttle body
5. Idle mixture needle
6. Idle jet
7. Fuel inlet needle & seat
8. Float shaft
9. Float
10. Venturi
- 11A & 11B. Mainjet
12. Plug
13. Float chamber
14. Well vent
15. Main discharge jet
16. Choke valve

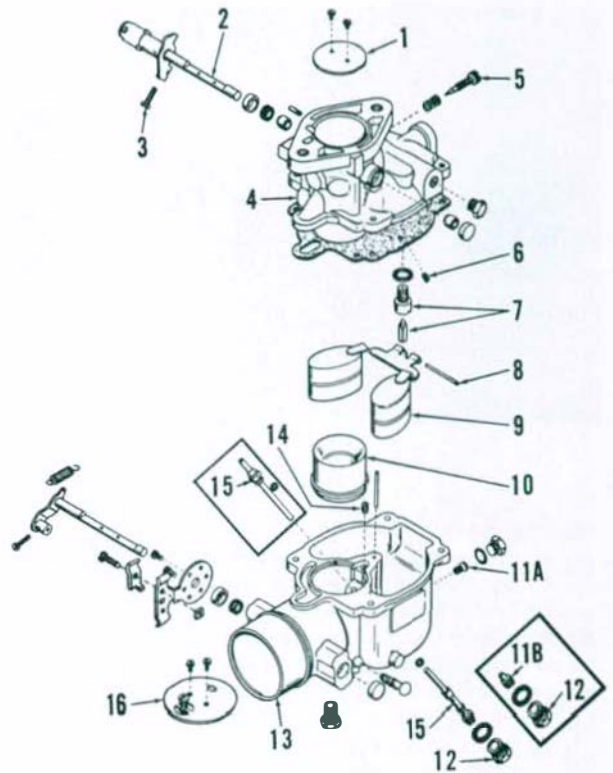

RELIEF VALVE

All Gasoline Models

45. The plunger type oil pressure relief valve (10 through 14—Fig. 42) is located in oil pump body. Normal operating oil pressure should be not less than 50 kPa (7 psi) at low idle and 140-205 kPa (20-30 psi) at 1800 rpm. Relief valve setting is adjustable by varying the number of adjusting shims (13).

The relief valve spring (11) should have a free length 49.2-52.4 mm (1-15/16 to 2-1/16 inches). Spring should test 57.3-59.5 N (12.9-13.3 pounds) when compressed to working length of 34.9 mm (1.375 inches).

CARBURETOR

All Gasoline Models

46. ADJUSTMENT. Zenith carburetors are used on all models. The smaller OE3435 carburetor (B—Fig. 43) is used on MF230 models, while 13795 is used on MF235 and MF245 models. Initial setting of idle mixture needle (1) is 2 to 2-1/2 turns open from closed position on the smaller carburetor, 5/8 to 3/4 turn open for the larger 13795 carburetor (A). Final adjustment should be made with engine operating at normal temperature. After mixture is correctly set, adjust low idle speed to 725-775 rpm for all models.

47. OVERHAUL. Zenith OE3435 carburetor used on MF230 model tractors is smaller and slightly different than the 13795 carburetor used on MF235 and MF245 model tractors. Refer to Fig. 43.

To disassemble the removed carburetor, first clean outside with a suitable solvent. Remove the screws retaining throttle body (4—Fig. 44) to fuel bowl (13) and remove fuel bowl. Remove float shaft (8), float and inlet valve needle.

NOTE: Float shaft (8) is a tight fit in slotted side of hinge bracket and should be removed from opposite side.

Remove venturi (10), inlet valve seal and idle jet (6) from throttle body. Remove idle adjusting needle (5). Remove

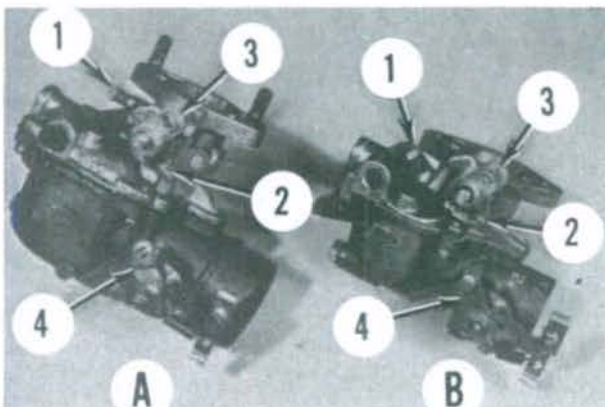

Fig. 43—Carburetor (A) is Zenith 13795 used on MF235 and MF245 models. Carburetor (B) is Zenith OE3435 used on MF230 models.

1. Idle mixture
2. Idle speed stop screw
3. Throttle arm
4. Choke arm

plug (12), discharge jet (15), main jet (11A) and well vent jet (14) from fuel bowl. Remove throttle and choke valves, shafts and packing.

Discard all gaskets and packing and clean remainder of parts in a suitable carburetor cleaner. Rinse in clean mineral solvent and blow out passages in body and bowl with compressed air. Renew all gaskets and packing and any other parts which are worn or damaged. Refer to Fig. 44 and the following specifications for the two different carburetors.

**Zenith 13795**

Venturi (10)	21 mm
Main Jet (11A) . . . No. 27	1.35 mm
Idle Jet (6) . . . . . No. 16	0.80 mm
Idle Air	
Restriction . . . . . No. 28	...
Main Discharge	
Jet (15) . . . . . No. 60	2.80 mm
Well Vent (14) . . . No. 20	1.00 mm
Fuel Valve	
Seat (7) . . . . . No. 35	1.75 mm

**Zenith OE3435**

Venturi (10) . . . . .	15 mm
Main Jet (11B) . . . No. 18	0.95 mm
Idle Jet (6) . . . . . No. 11	0.55 mm
Main Discharge	
Jet (15) . . . . . No. 55	2.75 mm
Well Vent (14) . . . No. 22	1.1 mm
Fuel Valve	
Seat (7) . . . . . No. 35	1.75 mm

Assemble by reversing the disassembly procedure, using new gaskets and packing. Install throttle plate (1) so beveled edges will fit throttle body bore with throttle closed, with side of throttle plate farthest from mounting flange aligned with idle port. Adjust float height to 7.14 mm (9/32 inch) for MF230 models, 3.97 mm (5/32 inch) for MF235 and MF245 models. Measure float height from gasket to nearest edge of float as shown in Fig. 45. Drill bits can

be used as gages as shown. If adjustment is required, carefully bend float arms using needle nose pliers or a bending tool, keeping the two halves of float parallel and equal. Check idle mixture and idle speed adjustments after installation as outlined in paragraph 46.

**GOVERNOR**

**All Gasoline Models**

**48. ADJUSTMENT.** Start engine and be sure ignition is correct. Adjust idle

speed stop screw (2—Fig. 43) to obtain correct idlespeed of 725-775 rpm. Adjust mixture needle to obtain highest smoothest idle, then readjust idle speed if necessary.

Stop engine and disconnect carburetor link (1—Fig. 48) from governor arm (2). Move hand throttle lever to maximum (fast) position to create tension on spring. Move carburetor rod (1) to wide open position and adjust length of rod until approximately 1 mm (1/32 inch) too short. Reconnect rod after adjustment is correct. High no-load speed should be adjusted to 2200-2250 rpm for MF230 models; 2425-2500 rpm for all MF235 and MF245 models. High speed adjustment is accomplished by changing the length of rod (3).

Initial adjustment of linkage can be accomplished as follows: Measure length of rod (3—Fig. 48) from centerline of rod end at top to lower end of sleeve inside spring. Correct distance is 236.5 mm (9-5/16 inches) for MF230 models; 239.7 mm (9-7/16 inches) for MF235 and MF245 Orchard models; 242.9 mm (9-9/16 inches) for all other MF235 and MF245 models. Correct length from center-to-center of rod (4—Fig. 46 or 47) is 565.2 mm (22-1/4 inches) for MF235

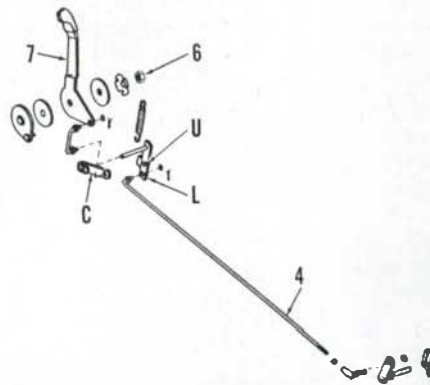

Fig. 46—Drawing of throttle control linkage typical of all except Orchard models. Refer to text for points of adjustment and to Fig. 47 for legend.

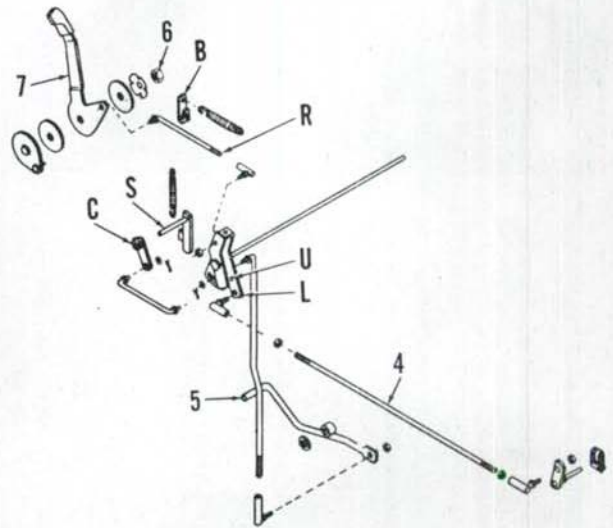

Fig. 47—Drawing of throttle linkage typical of Orchard models.

- 4. Throttle rod
- 5. Foot throttle pedal
- 6. Friction adjusting nut
- 7. Hand throttle lever
- B. Spring bracket
- C. Clamp arm
- L. Lower hole
- R. Rear rod
- S. Arm
- U. Upper hole

Fig. 48—View of governor linkage mounted at front of engine.

- 1. Carburetor control rod
- 2. Governor control lever
- 3. Governor rod
- 4. Throttle rod

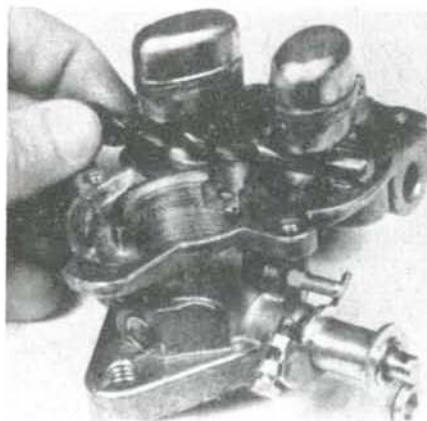
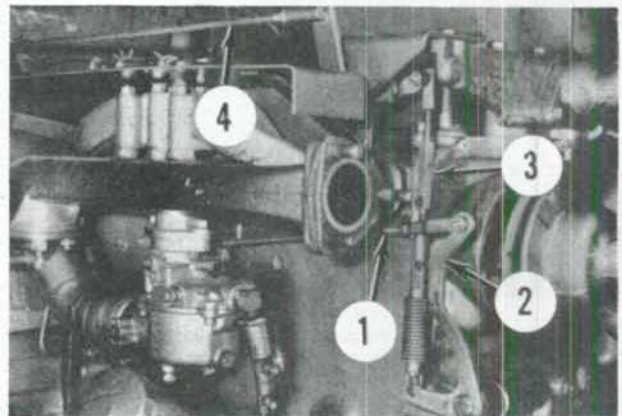

Fig. 45—Drill bit of correct size can be used as shown to check float height.





and MF245 Orchard models; 701.7 mm (27.5/8 inches) for all other models. Rear end of throttle rod (4) should be in upper hole (U) for rear spring arm for MF235 and MF245 models; lowest hole (L) of rear spring arm for MF230 models. On Orchard models, length of rear rod (R—Fig. 47) should be 177.8 mm (7 inches) and spring bracket (B) should be clamped to rod 120.7 mm (4-3/4 inches) from centerline of ball joint at front. Loosen clamp arm (C), align with arm (S), then retighten clamp. On all except Orchard models, loosen clamp arm (C—Fig. 46) and position hand lever 6.4 mm (1/4 inch) from low speed stop position. Move the governor arm lever (2—Fig. 48) towards carburetor (closed position), then tighten clamp arm (C—Fig. 46.)

**49. OVERHAUL.** To overhaul the governor, first remove timing gear cover

as outlined in paragraph 34. The governor lever shaft is supported in needle bearings in timing gear cover. To service the shaft, bearings or oil seals, remove the pipe plug from front of timing gear cover, drive out the groove pin and withdraw the lever. The dust seal (felt) and the oil seal (lip toward inside) can be renewed at this time. To remove needle bearings, drive the bearing stop pin in until it falls into shaft bore (Fig. 49). Remove the stop pin, then drive the needle bearings out of cover bore.

Grease shaft needle bearings before installing. Drive inside bearing into bore until just past hole for locating pin, then install the locating pin. Drive outer bearing in until it is flush with counterbore for oil seal. Drive oil seal into bore with lip toward inside until the seal bottoms in counterbore. Assemble felt seal, shaft and rocker lever into cover, then in-

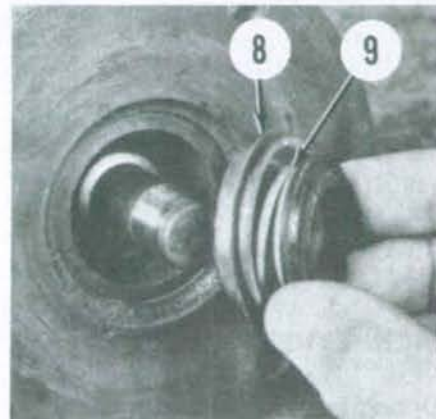

Fig. 52—The gasket (8) should be in position around seal as shown when installing the spring seal (9).

stall roll pin through rocker lever and shaft.

Governor ball and driver assembly (3—Fig. 50) is available only as a unit which can be renewed after removing camshaft nut (2). Tighten the camshaft nut to a torque of 95-108 N·m (70-80 ft.-lbs.).

Withdraw thrust cup assembly (1), make sure the lip tab (L) is not broken or shaft is not scored. Also check ball race for channeling. Plunger bore in camshaft is vented by a drilling which emerges from shaft just to rear of front cam; governor action will be impeded if vent is plugged.

Before installing timing gear cover, turn the cup assembly (1) until tab (L) is at 6 o'clock position.

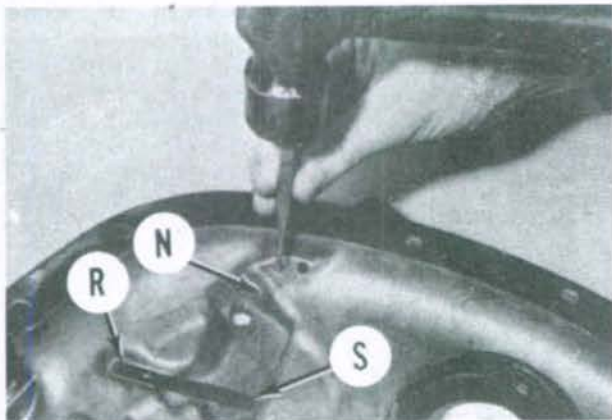

Fig. 49—The locating stop pin can be driven out with punch as shown. Both bearings can be removed from inner end (N). The governor bumper spring (S) is attached to cover with rivets (R).

**COOLING SYSTEM**

**All Gasoline Models**

**50. RADIATOR.** All models use a 48 kpa (7 psi) pressure type radiator cap. Cooling system capacity is 9.5 L (10 U.S. quarts). Be sure all pads, braces and

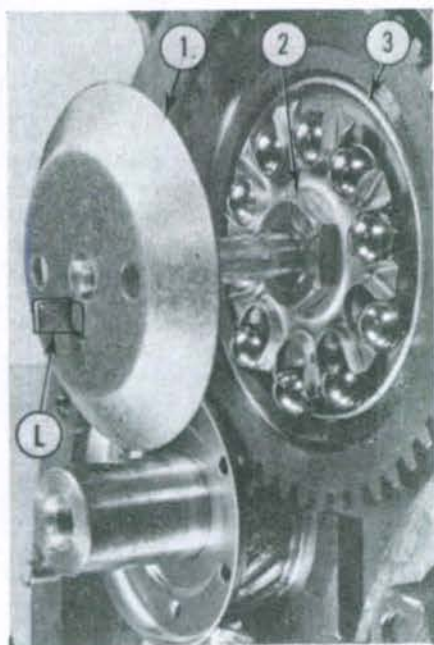

Fig. 50—Camshaft mounted governor weight unit and associated parts of the type used on gasoline engine.

- 1. Race & shaft
- 2. Camshaft nut
- 3. Weight unit
- L. Lip

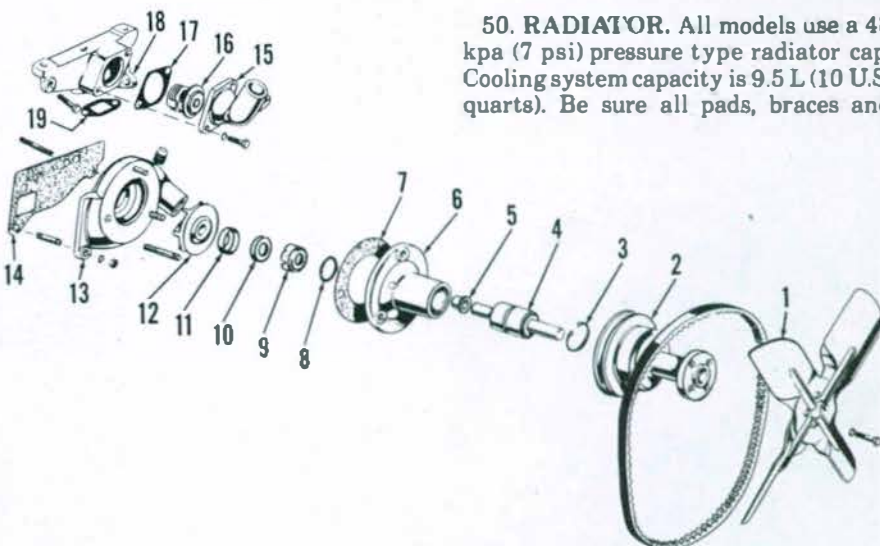

Fig. 51—Exploded view of water pump assembly used on gasoline models.

- 1. Fan
- 2. Pulley
- 3. Snap ring
- 4. Shaft & bearing assy.
- 5. Slinger
- 6. Pump body
- 7. Gasket
- 8. Gasket
- 9. Spring seal assy.
- 10. Ceramic collar
- 11. Rubber collar retainer
- 12. Impeller
- 13. Rear housing
- 14. Gasket
- 15. Outlet adapter
- 16. Thermostat
- 17. Gasket
- 18. Thermostat housing
- 19. Gasket

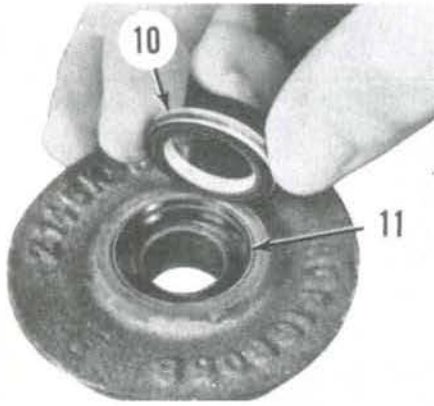

Fig. 53—Install the ceramic collar (10) into rubber retainer (11) with the three holes in collar toward the impeller.

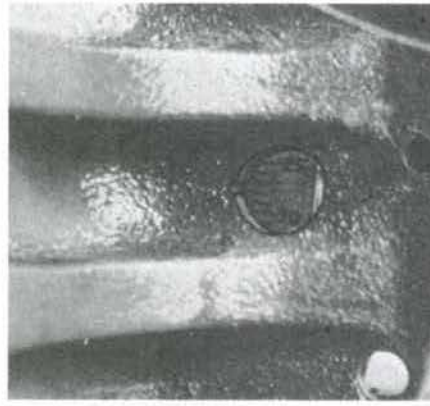

Fig. 55—Ignition timing marks on flywheel are visible through timing hole as shown.

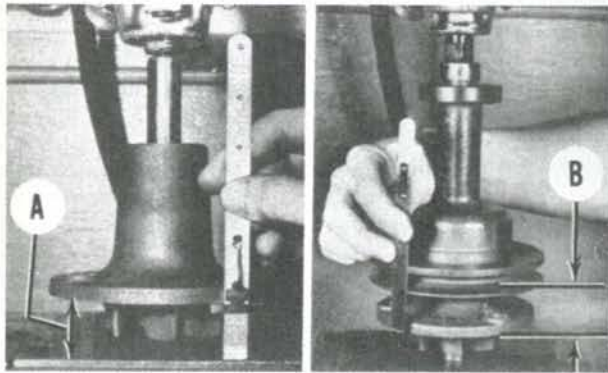

Fig. 54—Press impeller onto shaft until distance (A) from rear surface of impeller to gasket surface of body is 22.35-24.38 mm (0.880-0.960 inch). Press pulley on until distance (B) from center of "V" groove to gasket surface of pump is 42.86 mm (1.11/16 inches).

shrouds are installed in correct locations to assure proper cooling.

**51. THERMOSTAT.** The thermostat is contained in a separate housing behind the outlet elbow. The thermostat should begin to open at 81°C (178°F) and be fully open at 93°C (200°F).

**52. WATER PUMP.** Drain cooling system, remove fan and belt, then unbolt and remove water pump from rear housing. The rear housing can be unbolted and removed after pump is off and lower radiator hose is disconnected.

Remove pulley (2—Fig. 51) using a puller attached to fan mounting hub. Remove snap ring (3), then press shaft and bearing (4) toward front out of impeller (12) and pump body (6).

To assemble, install slinger (5) onto short end of shaft (4), then press the shaft and bearing assembly into body (6) until bearing bottoms in bore. Install snapping (3). Coat outside of seal (9) with sealing compound, position gasket (8) around seal, then install in housing with carbon face toward impeller as shown in Fig. 52. Install the rubber collar retainer (11—Fig. 51) in bore of impeller (12), then insert ceramic collar (10) as shown in Fig. 53. Be sure side with three holes is toward impeller. Press impeller onto shaft with open side of blades out until

distance (A—Fig. 54) is 22.35-24.38 mm (0.880-0.960 inch). Support shaft and press pulley onto shaft until distance (B)

from center of pulley groove to mounting surface of water pump is 42.86 mm (1.11/16 inches). Water pump mounting holes are offset permitting installation only one way.

**IGNITION**

**All Gasoline Models**

**53. TIMING.** Timing marks are located on flywheel with a timing window on left side of engine block as shown in Fig. 55. Initial (static) timing should occur at 8 degrees BTDC. Maximum advance should be 27 degrees (crankshaft) at 2200-2250 engine rpm; 28 degrees (crankshaft) at 2425-2500 engine rpm. These rpm ratings are the recommended high idle no-load governed speeds for MF230 models (2200-2250 rpm); MF235 and MF245 models (2425-2500 rpm). Firing order is 1-3-4-2. Distributor shaft rotation is counterclockwise viewed from above (rotor end).

To install distributor, be sure breaker point gap is 0.43-0.56 mm (0.017-0.022 inch) which should provide dwell of 66-72 degrees. Turn crankshaft slowly until number one piston begins coming up on compression stroke, then stop when 8 degree BTDC mark is visible in timing hole (Fig. 55). Install distributor with rotor pointing toward number one spark plug. The distributor body should be rotated until wire to coil is straight to rear. Install distributor clamp finger tight. Turn distributor clockwise until

Fig. 56—Exploded view of the distributor used. Gear (20) is driven by the teeth of gear on engine camshaft.

1. Cap
2. Rotor
3. Cover
4. Breaker points
5. Condenser
6. Breaker plate
7. Snap ring
8. Cam assy.
9. Spacer
10. Weights
11. Light spring
12. Heavy spring
13. Distributor shaft
14. Shouldered washer
15. Flat washer
16. Needle bearing
17. Housing
18. Bushing
19. Washer
20. Drive gear
21. Pin
22. Gasket
23. Tachometer drive gear & flat washer
24. Drive housing
25. Adapter pin
26. Angle drive
27. Distributor clamp

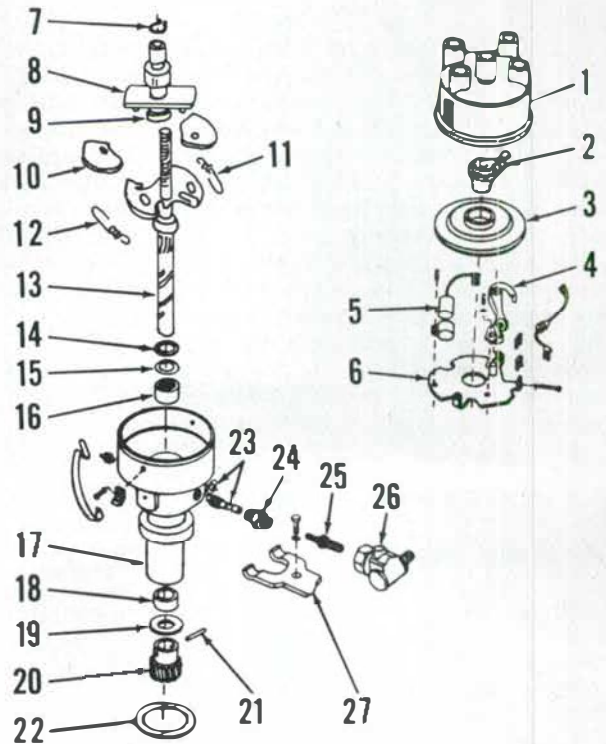

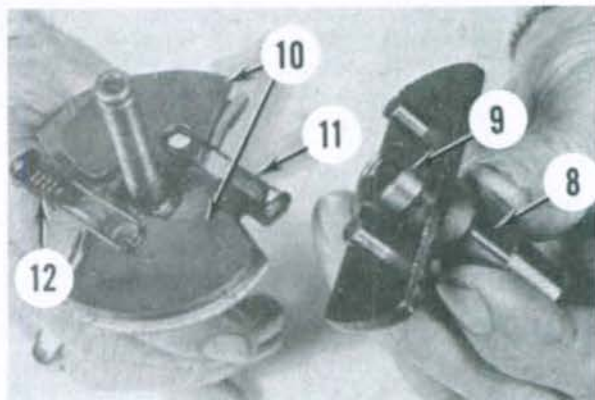

Fig. 57—Lugs on cam assembly (8) should go through springs (11 and 12), weights (10) and slots in plate of the distributor shaft. Spacer is shown at (9).

breaker points just start to open, then tighten distributor clamp screw enough to hold distributor position. Start engine and check running timing at high idle no-load rpm.

**54. OVERHAUL.** Refer to Fig. 56 for exploded view of the Prestolite 1BT 4406 distributor used on all models. Disassembly is by removing breaker plate (6), clip (7) and pin (21).

Assemble parts (8,9,10,11 and 12) as shown in Fig. 57, then install snap ring (7—Fig. 56). The shouldered washer (14) should be above and should enclose flat washer (15). Distributor shaft end play should be 0-0.25 mm (0-0.010 inch). Breaker point gap of 0.43-0.56 mm

(0.017-0.022 inch) should provide dwell of 66-72 degrees. Breaker point spring tension should be 4.7-6.1 N (17-22 ounces).

Delco-Remy 1115065 ignition coil is used on all models. Primary winding resistance should be 3.3-4.1 ohms at 24°C (75°F). Secondary winding at the same temperature should be 3000-20000 ohms.

**55. SPARK PLUGS.** Recommended spark plugs are Champion RD-16, Massey-Ferguson MF834242 M1 or equivalent. Electrode gap should be 0.64 mm (0.025 inch). Manufacturer recommends renewing spark plugs after every 300 hours of operation.

with a jack stand under transmission housing. Remove bolts attaching axle support to front of engine, then roll front end assembly away from engine.

To separate engine from transmission, proceed as follows: Shut off fuel, disconnect fuel lines and remove fuel tank. Disconnect air cleaner hose. Disconnect injection pump stop control and throttle control. Disconnect wiring from engine and starter motor. Remove starter motor and solenoid. Disconnect tachometer drive cable from engine. Remove bolts attaching steering box side panels to rear of engine. Remove muffler (or exhaust pipe) from exhaust manifold. Support engine with a hoist, remove bolts attaching engine to transmission and carefully move engine forward from transmission.

To reinstall engine, reverse the removal procedure while noting the following special instructions: Install an alignment stud in each side of transmission housing to assist in aligning engine to transmission. Turn flywheel to align clutch plate splines with transmission and pto input shaft splines. After engine and transmission flanges meet, install retaining bolts and nuts and tighten to 75 N·m (55 ft.-lbs.) torque. Tighten front axle support mounting bolts and nuts to 235 N·m (175 ft.-lbs.) torque. Check clutch linkage adjustment as outlined in appropriate paragraph 110 or 111.

## DIESEL ENGINE AND COMPONENTS

All models equipped with diesel engine use Perkins AD3.152 direct injection diesel engine. Different versions of the AD3.152 engine have been used and can be identified by the serial number suffix letters stamped on pad located near the fuel transfer pump on right side of engine. Some service procedures will differ slightly depending on whether or not there is an "S" in serial number suffix letters. Engines with letter "L" in suffix code use a one-piece lip type crankshaft rear oil seal. Engines that do not have letter "L" in suffix code use a two-piece rope type crankshaft rear oil seal.

### R&R ENGINE ASSEMBLY

#### All Diesel Models

**56.** To remove engine, first remove front end assembly from engine as follows: Drain cooling system. Remove hood, grille, side panels and radiator brace. Disconnect battery cables and remove the battery. Disconnect

headlight wires and thread wiring rearward through the retainer clips. Disconnect radiator upper and lower hoses, oil cooler hoses and power steering hoses. Disconnect drag links from steering box pitman arms. Drive wooden wedges between front axle and axle support to prevent tipping. Remove front end weights if so equipped. Support front end assembly with a hoist. Support tractor

### CYLINDER HEAD

#### All Diesel Models

**57. REMOVE AND REINSTALL.** To remove cylinder head, first drain cooling system. Remove hood and instrument panel cover. Disconnect battery cables and remove battery. Shut off fuel, disconnect fuel gage sending unit wire, disconnect fuel supply and return lines, and remove fuel tank and mounting brackets. Disconnect radiator top hose and thermostat bypass hose. Disconnect breather pipe and remove rocker arm cover. Remove retaining nuts and lift off

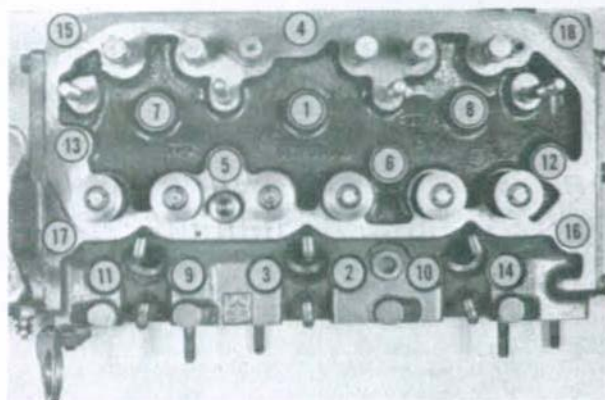

Fig. 58—On early production engines (prior to Serial No. 152UA 2841D5L), use sequence shown when tightening cylinder head cap screws. Reverse the sequence when loosening cap screws.

rocker shaft assembly. Remove intake manifold and exhaust manifold. Remove high pressure fuel lines, then remove injector nozzles and sealing washers from cylinder head. Remove stabilizer bar from thermostat housing. Disconnect external oil supply line from cylinder head. Loosen cylinder head mounting stud nuts or cap screws in reverse order of tightening sequence shown in appropriate Fig. 58 or 59, then lift cylinder head from the engine.

Clean gasket surface of cylinder head and check for warpage or other damage. Cylinder head can be surfaced and a maximum of 0.30 mm (0.012 inch) material may be removed provided injector nozzles do not protrude more than 4.67 mm (0.184 inch). Do not attempt to use additional injector sealing washers to reduce nozzle protrusion. Refer to paragraph 59 to determine whether valves must be resealed to provide proper recession after cylinder head is resurfaced.

When reinstalling cylinder head, make certain all sealing surfaces and cap screw holes are clean and dry. Lightly oil threads of cylinder head stud nuts and cap screws. Tighten nuts and cap screws in three equal stages following sequence shown in Fig. 58 or 59 to a final torque of 95 N·m (70 ft.lbs.). Tighten rocker bracket cap screws to a torque of 30 N·m (22 ft.lbs.). Adjust valve clearance as outlined in paragraph 58. Complete installation by reversing the removal procedure. Operate engine until normal operating temperature is reached, then retorque cylinder head and readjust valves.

**VALVE CLEARANCE**

**All Diesel Models**

58. The recommended cold valve clearance is 0.30 mm (0.012 inch) for both the intake and exhaust valves. Hot valve clearance, engine at normal operating temperature, should be 0.25 mm (0.010 inch) for all valves. Static setting of all valves can be made from just

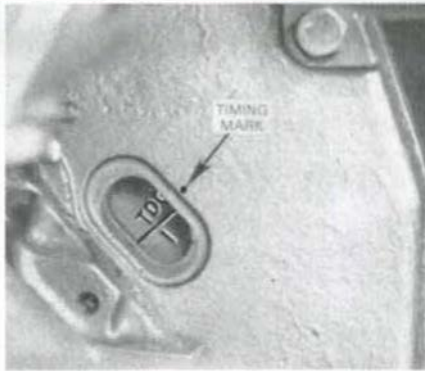

Fig. 60—TDC timing marks aligned for valve adjustment as outlined in paragraph 58.

two crankshaft positions using the following procedure:

Remove timing window plug from left side of flywheel adapter housing. Turn crankshaft until TDC timing mark on flywheel is aligned with punch mark as shown in Fig. 60 and No. 1 piston is on compression stroke (both valves closed). Adjust clearances on No. 1,2,3 and 5 valves as shown in Fig. 61. Turn crankshaft one complete turn until TDC mark is again aligned with punch mark, then adjust remaining two valves (Fig. 62).

**VALVES AND SEATS**

**All Diesel Models**

59. When disassembling cylinder head, keep valves in order so they can be installed in their original positions if reused. On some engines, valve heads and seat locations are numbered consecutively from front to rear. Any replacement valves should be marked prior to installation.

Intake and exhaust valves seat directly in cylinder head. Valve seat inserts are available for service installation on exhaust valves only on some models. Cylinder head must be machined for installation of valve seat inserts; refer to Fig. 64 for dimensions. Chill insert in dry ice prior to installation, then press in-

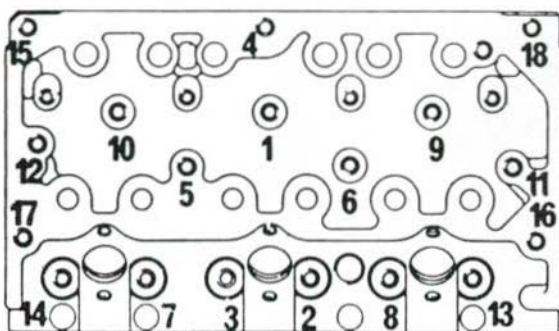

Fig. 59—On late production engine (Serial No. 152UA 28411DSL end after), use sequence shown when tightening cylinder head cap screws. Reverse the sequence when loosening cap screws.

sert squarely into cylinder head counter-bore using the valve guide as a pilot. Grind seat insert as necessary to recess valve the recommended distance from head gasket surface.

Valve face and seat angle is 35° for both intake and exhaust of engines with letter "S" or "F" in serial number suffix. Engines without letter "S" or "F" in serial number suffix are equipped with intake and exhaust valves with 45° face angle. Original production valve seat angle on these engines is 46°, but seats can be refaced to 45° when servicing valves. On all models, desired seat contact width is 1.6 mm (1/16 inch) for intake and 2.4 mm (3/32 inch) for exhaust.

Valve head should be recessed a specified amount below face of cylinder head. Clearance can be measured with a straightedge and feeler gage as shown in Fig. 63. Refer to the following specifications:

**With "S" or "F" Serial Number Suffix**

**Valve Face and Seat**

**Angle—**

Intake and Exhaust ..... 35°

**Valve Head**

**Recession—**

Intake ..... 1.32-1.63 mm  
(0.054-0.064 in.)

Exhaust ..... 1.6(0-1.92 mm  
(0.063-0.075 in.)

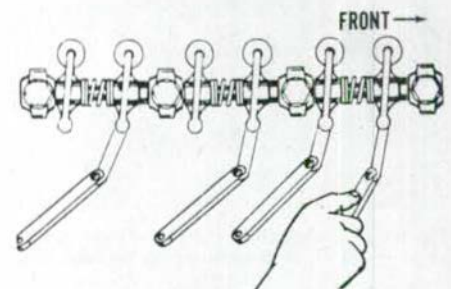

Fig. 61—With TDC timing marks aligned and No. 1 piston on compression stroke, adjust the valves indicated. Turn crankshaft one revolution and refer to Fig. 62.

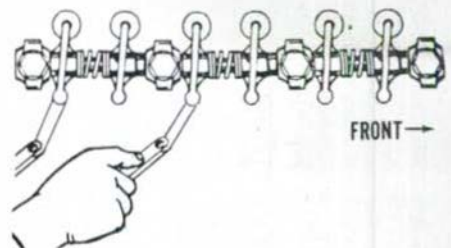

Fig. 62—With TDC timing marks aligned and No. 1 piston on exhaust stroke, adjust the valves indicated.

VALVE SPRINGS

All Diesel Models

61. Springs, caps, retainers and locks are interchangeable for intake and exhaust valves. Springs may be installed either end up. Renew springs if discolored, distorted or if they fail to meet the following specifications:

Spring free length should be approximately 45.30 mm (1-25/32 inches). Spring pressure should be 93-110 N (21-25 pounds) when compressed to 38.1 mm (1.5 inches).

CAM FOLLOWERS

All Diesel Models

62. The mushroom type cam followers (tappets) operate directly in machined bores in cylinder head. With cylinder head removed, cam followers can be removed after first removing adjusting screw and locknut from top of cam follower. Identify cam followers as they are removed so they can be reinstalled in their original positions if reused. Always renew cam followers whenever camshaft is renewed.

Cam follower diameter is 15.81-15.84 mm (0.6225-0.6237 inch). Diametral clearance in cylinder head bores should be 0.02-0.09 mm (0.0008-0.0035 inch).

Valve Stem  
Diameter—  
Intake and  
Exhaust ..... 7.90-7.92 mm  
(0.311-0.312 in.)  
Wear Limit ..... 7.87 mm  
(0.310 in.)

Stem to Guide  
Clearance—  
Intake and  
Exhaust ..... 0.06-0.11 mm  
(0.0025-0.0045 in.)

Without "S" or "F" Serial  
Number Suffix

Valve Face and  
Seat Angle—  
Intake and Exhaust ..... 45°

Valve Head  
Recession—  
Intake and  
Exhaust ..... 1.50-2.13 mm  
(0.059-0.084 in.)

Valve Stem  
Diameter—  
Intake and  
Exhaust ..... 7.90-7.92 mm  
(0.311-0.312 in.)  
Wear Limit ..... 7.87 mm  
(0.310 in.)

Stem to Guide  
Clearance—  
Intake and  
Exhaust ..... 0.06-0.11 mm  
(0.0025-0.0045 in.)

VALVE GUIDES

All Diesel Models

60. Intake and exhaust valve guides can be renewed if excessively worn. Using a suitable removal tool, press guides out top of cylinder head. The guides are interchangeable. Note that both ends of guides are chamfered, one end at 45° and the other at 20°. Be sure to insert 20° chamfered end into top of cylinder head (45° chamfered end up). Press into place until top end protrudes 14.83-15.09 mm (0.584-0.594 inch) above spring seat surface of cylinder head. Replacement valve guides are resized and do not require reaming if carefully installed. After renewing valve guides, reface valve seats to ensure concentricity of seat to guide.

Valve guide specifications are as follows:

Valve Guide I.D. .... 7.98-8.01 mm  
(0.3142-0.3155 in.)

Valve Stem O.D. .... 7.90-7.92 mm  
(0.311-0.312 in.)

Stem-to-Guide  
Clearance ..... 0.06-0.11 mm  
(0.0025-0.0045 in.)



Fig. 63—A straightedge and feeler gage can be used as shown to determine how far valves are recessed.

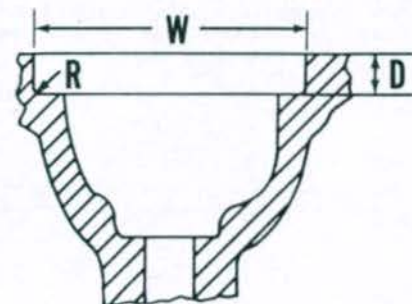

Fig. 64—Machining dimensions for installing exhaust valve seat inserts available for some engines.

D, 7.87-7.92 mm  
(0.310-0.312 in.)  
W, 42.62-42.64 mm  
(1.678-1.679 in.)  
R, 0.38 mm (0.015 in.)  
radius

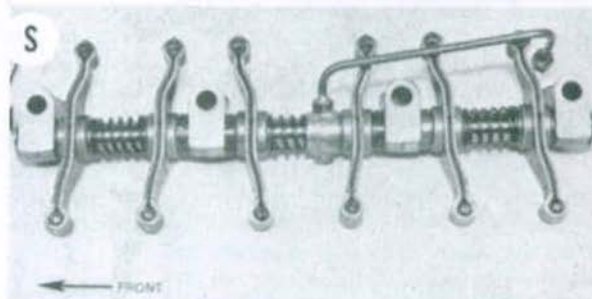

Fig. 65—Assembled view of rocker arm assembly. Slot (S) in end of shaft should be toward front.

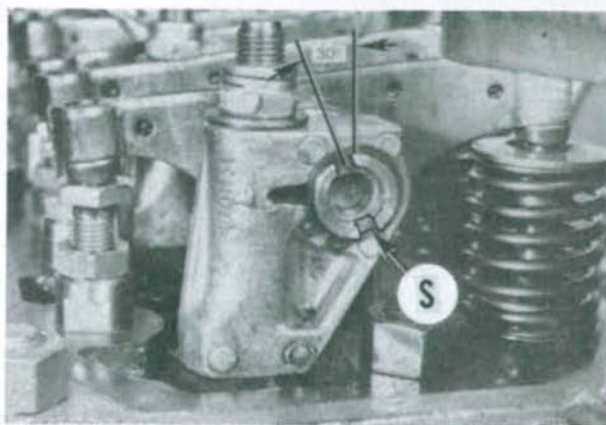

Fig. 66—Slot (S) in front end of rocker shaft should be positioned approximately 30° from vertical as shown. Late production engines use a dowel pin through one of the support brackets to correctly position shaft.

ROCKER ARMS

All Diesel Models

63. The rocker arms and shaft assembly can be removed after removing the hood, fuel tank and rocker arm cover. The rocker arms are right-hand and left-hand units and should be installed on shaft as shown in Fig. 65.

Rocker shaft diameter is 15.81-15.84 mm (0.6225-0.6237 inch) and desired diametral clearance between shaft and rocker arms is 0.02-0.09 mm (0.0008-0.0035 inch). Renew shaft and/or rocker arms if clearance exceeds 0.13 mm (0.005 inch). The amount of oil circulating to the rocker arms is regulated by the position of the rocker shaft in the support brackets. This position is indicated by a slot (S—Fig. 66) in front end of shaft and should be set at approximately 30° from vertical as shown. On late production engines, shaft is positioned correctly by a dowel pin in one of the support brackets.

TIMING GEAR COVER

All Diesel Models

64. To remove the timing gear cover, drain the cooling system and oil pan. Remove front grille panels and disconnect battery cables. Remove fuel tank cap, radiator cap and hood. Disconnect headlight wires and pull wiring free. Disconnect both radiator hoses, radiator brace and, on models so equipped, hydraulic oil lines and front mounted pump. Support tractor at front of transmission. Position wedge blocks between front axle and axle support. Support the front end assembly at front and

rear. Disconnect drag links and radius rods at rear of models so equipped. On models with drag links, attach drag links to axle so wheels will be straight ahead and will not turn. On models with power steering, disconnect lines and cover all hydraulic steering openings. Unbolt the front assembly and carefully roll away from tractor.

Remove the crankshaft pulley, fan belt, water pump and alternator mounts. Unbolt and remove the timing gear cover. Press, do not pry, old seal from cover. The camshaft thrust spring is riveted to rear face of timing gear cover and controls end play of camshaft.

To reinstall timing gear cover, first install a new oil seal into cover using suitable installing tool. Install timing gear cover with a new gasket on front of engine, but do not tighten mounting cap screws at this time. Lubricate lip of seal, then carefully position crankshaft pulley onto crankshaft to center seal and cover to the crankshaft. Hold cover in centered position while tightening several cover retaining cap screws. Remove crankshaft pulley, then tighten all cap screws securely. Reinstall crankshaft pulley and tighten retaining cap screw to 142 N·m (105 ft.-lbs.) torque. Complete installation by reversing the removal procedure.

TIMING GEARS

All Diesel Models

65. Fig. 67 shows a view of timing gear train with cover removed. Before attempting to remove any of the timing gears, first remove fuel tank, rocker arm cover and rocker arms assembly to avoid the possibility of damage to pistons or valve train if camshaft or crankshaft

should be turned independently of the other.

Timing gear backlash should be 0.08-0.15 mm (0.003-0.006 inch) between the large idler gear and any of the other gears in the timing train. Replacement gears are available in standard size only. If backlash is not within specified limits, renew the idler gear, idler gear shaft and/or any other gears concerned.

To remove the timing gears or time the engine, unstack and remove the idler gear retaining bolt and slip the gear off idler shaft. The idler shaft is a light press fit in timing gear housing and is further positioned by the locating pin shown in Fig. 68. Pry the shaft from its place in timing gear housing if renewal is indicated.

The crankshaft gear is keyed in place and fits the shaft with a transition fit, 0.025 mm (0.001 inch) tight to 0.025 mm (0.001 inch) loose. If the old gear is a loose fit, it may be possible to pry it off the shaft with a heavy screwdriver or light pry bar. If a puller is needed, it will first be necessary to remove the oil pan and small lower section of timing gear housing.

The camshaft gear and injection pump drive gear can be removed by removing the retaining cap screws and withdrawing the gears. To install the gears and time engine, refer to the appropriate following paragraphs:

66. CAMSHAFT GEAR. The gear is attached to camshaft by three equally spaced cap screws which thread into camshaft flange. It is possible, therefore, to install the gear in three positions, only one of which is correct. To correctly install the gear, align the stamped letters "D" on camshaft hub and front face of gear as shown at (X—Fig. 67). Tighten cap screws to 27 N·m (20 ft.-lbs.) torque.

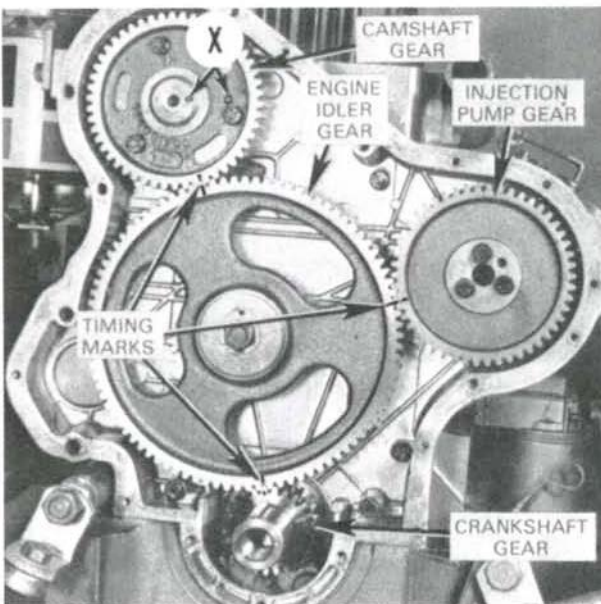

Fig. 67—View of timing gear train with timing marks aligned. Due to odd number of teeth on idler gear, marks align only once in 18 revolutions of crankshaft.

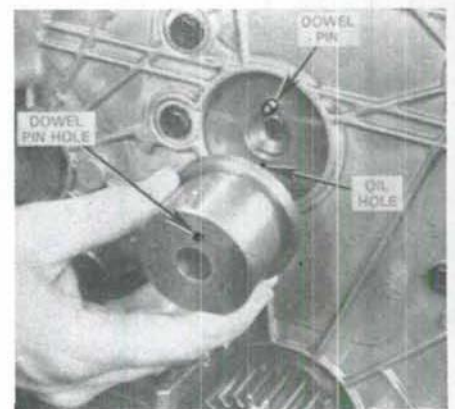

Fig. 68—The oil holes in cylinder block and idler gear stub shaft are correctly aligned by the locating dowel pin.

**67. INJECTION PUMP DRIVE GEAR.** The injection pump drive gear is retained to the pump adapter by three cap screws. When installing the gear, align dowel pin (2—Fig. 69) with slot (1) in adapter hub, then install the retaining cap screws. The injection pump drive gear and adapter are supported by the injection pump rotor bearings.

**68. IDLER GEAR.** The idler gear is retained on idler shaft by a cap screw and washer. Idler gear bore diameter should be 53.98-54.02 mm (2.125-2.127 inches) and idler shaft diameter should be 53.92-53.94 mm (2.123-2.124 inches). Gear to shaft diametral clearance should be 0.04-0.10 mm (0.0016-0.0039 inch). Gear end play on shaft should be 0.13-0.38 mm (0.005-0.015 inch).

When reinstalling gear, make certain all timing marks are aligned as shown in Fig. 67. Tighten retaining cap screw to 68 N·m (50 ft.-lbs.) torque.

**69. TIMING THE GEARS.** Due to the odd number of teeth on idler gear, the timing marks will align only once in 18 crankshaft revolutions. To time the engine after the gears are removed, first install camshaft gear as outlined in paragraph 66 and the injection pump gear as in paragraph 67. Install the crankshaft gear on keyed shaft with timing mark to the front. Refer to Fig. 67 and turn crankshaft, camshaft and injection pump until the respective timing marks point approximately toward idler gear hub; then, install idler gear aligning timing marks as shown.

**TIMING GEAR HOUSING**

**All Diesel Models**

**70.** To remove timing gear housing, first remove timing gear cover as outlined in paragraph 64, then remove timing gears as outlined in paragraph 65. Remove oil pan, fuel lift pump and injection pump. Remove power steering pump if not previously removed. Remove

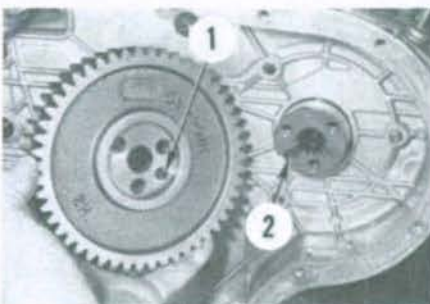

Fig. 69—Correct installation of injection pump drive gear is simplified by the dowel pin which fits in machined notch in pump drive shaft.

rocker arms and shaft assembly. Raise and secure cam followers in the fully raised position, then withdraw camshaft. Unbolt and remove timing gear housing. Reinstall by reversing the removal procedure.

**CAMSHAFT**

**All Diesel Models**

**71.** To remove the camshaft, first remove timing gear cover as outlined in paragraph 64. Remove fuel tank, rocker arm cover and rocker arms and shaft assembly. Raise and secure cam followers in their uppermost position. Remove fuel lift pump, then withdraw camshaft as shown in Fig. 70.

The camshaft runs in three journal bores machined directly in engine block. The front and rear camshaft bearings are gravity lubricated by return oil from the rocker arms. The center journal is pressure lubricated by an external oil line. The center journal, in turn, meters oil to the rocker shaft and cylinder head through a second short oil feed line.

Inspect camshaft lobes and bearing journals for excessive wear, scoring, pitting or other damage and renew if necessary. Recommended bearing journal diametral clearance in cylinder block bores is 0.10-0.20 mm (0.004-0.008 inch). It is recommended that cam followers also be renewed if camshaft is renewed. Camshaft end play is controlled by the leaf-type spring riveted to rear face of timing gear cover. Camshaft specifications are as follows:

Journal Diameter—	
Front	47.47-47.50 mm (1.869-1.870 in.)
Center	47.22-47.24 mm (1.859-1.860 in.)
Rear	46.71-46.74 mm (1.839-1.840 in.)
Cylinder Block Bore Diameter—	
Front	47.60-47.67 mm (1.874-1.877 in.)

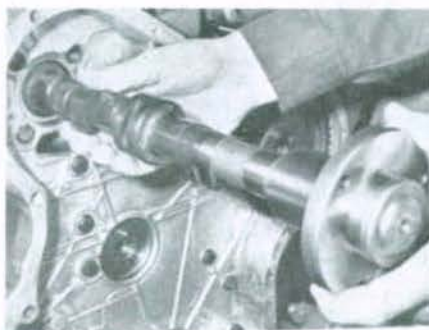

Fig. 70—The camshaft can be withdrawn as shown. The gear may remain installed.

Center	47.35-47.42 mm (1.864-1.867 in.)
Rear	46.84-46.91 mm (1.844-1.847 in.)

To reinstall camshaft, reverse the removal procedure. If camshaft gear was removed, be sure stamped letters (X—Fig. 67) on gear and camshaft flange are aligned. Tighten gear retaining cap screws to 27 N·m (20 ft.-lbs.) torque.

**ROD AND PISTON UNITS**

**All Diesel Models**

**72.** Connecting rod and piston units are removed from above after removing cylinder head, oil pan and rod bearing caps. Be sure to remove carbon and ring wear ridge (if present) from top of sleeves before pushing pistons out of cylinders.

Cylinder numbers are stamped on the connecting rods and caps. When reinstalling rod and piston units, make certain the numbers are in register and face away from camshaft side of engine. Refer to Fig. 71.

Connecting rod cap nuts and bolts should be renewed whenever they are removed. Note that two different types of connecting rod nuts, with different



Fig. 71—Assemble rod and piston units as shown. A. FRONT or F mark B. Cylinder number C. Connecting rod correlation marks

tightening torque values, have been used. Early models used cadmium plated (bright finish) nuts while later models use phosphated (dull black finish) nuts. Do not intermix the different types of nuts. Connecting rod nuts should be tightened to the following torque values: 61 N·m (45 ft.lbs.) for cadmium plated nuts and 81 N·m (60 ft.lbs.) for phosphated nuts.

**PISTONS, SLEEVES AND RINGS**

**All Diesel Models**

73. The aluminum alloy, cam ground pistons are supplied in standard size only and are available in a kit consisting of piston, pin and rings for one cylinder. The toroidal combustion chamber is offset in piston crown and piston should be marked "FRONT" or "F" for proper assembly as shown in Fig. 71. If "FRONT" or "F" marking is not present on piston crown, assemble piston to connecting rod with the cavity offset towards side of rod that is stamped with cylinder identification number.

Five piston rings (Fig. 72) are used in engines with serial number suffix "D" or "DL." The first (top) ring is chrome plated, parallel faced and may be installed either side up. The second ring is cast iron, parallel faced and may also be installed either side up. The third compression ring consists of four steel segments as shown in Fig. 72. The segments appear practically flat when not under compression, but when compressed as shown in Fig. 73 the ends will curl up (or down if ring is turned over). Ring ends should curl down on segment installed at bottom of groove, up on second, down on third and up on top segment. Space end gaps of the four segments 180 degrees apart from nearest segment. The fourth ring is

chrome plated, laminated, oil control ring. To install, first install the internal expander, install the two lower rails, spiral ring, then the top two rails. Stagger the gaps of the ring segments around the piston. The fifth (bottom) oil control ring is nondirectional and may be installed with either side up. Piston and ring specifications are as follows:

**Five-Ring Pistons**

**Piston Skirt**

Diameter\* . . . . . 91.326-91.351 mm  
(3.5955-3.5965 in.)

**Ring Side Clearance**

**in Groove—**

Top & Second . . . . . 0.05-0.10 mm  
(0.002-0.004 in.)  
Third & Fourth . . . . . Not applicable  
Bottom . . . . . 0.05-0.10 mm  
(0.002-0.004 in.)

**Ring End Gap—**

Top . . . . . 0.36-0.76 mm  
(0.014-0.030 in.)  
Second . . . . . 0.28-0.69 mm  
(0.011-0.027 in.)  
Third  
(each segment) . . . . . 0.25-0.38 mm  
(0.010-0.015 in.)  
Fourth (each rail) . . . . . 0.46-0.94 mm  
(0.018-0.037 in.)

Bottom . . . . . 0.28-0.69 mm  
(0.011-0.027 in.)

\* Skirt diameter measured at bottom of piston, 90° from piston pin bore.

Four piston rings (Fig. 74) are used in engines with serial number suffix "DS" or "DLS." The first (top) ring is chrome plated and may be installed either side up. The second and third rings are alike and are internally stepped. The groove cut into the inner diameter should be toward top as shown in Fig. 74. The bottom (fourth) ring is nondirectional with a coil spring expander. Install the expander groove first being sure the latch pin engages both ends of spring as shown in Fig. 75, then install the ring over the expander. Piston and ring specifications are as follows:

**Four-Ring Pistons**

**Piston Skirt**

Diameter\* . . . . . 91.336-91.361 mm  
(3.5959-3.5969 in.)

**Ring Side Clearance**

**in Groove—**

Top . . . . . 0.05-0.10 mm  
(0.002-0.004 in.)  
Second & Third . . . . . 0.05-0.10 mm  
(0.002-0.004 in.)  
Bottom . . . . . 0.05-0.11 mm  
(0.002-0.0045 in.)

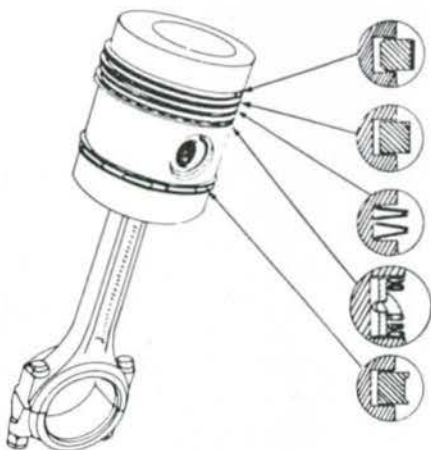

Fig. 72—Drawing of five-ring piston showing cross-section of the rings correctly installed. Refer to text.

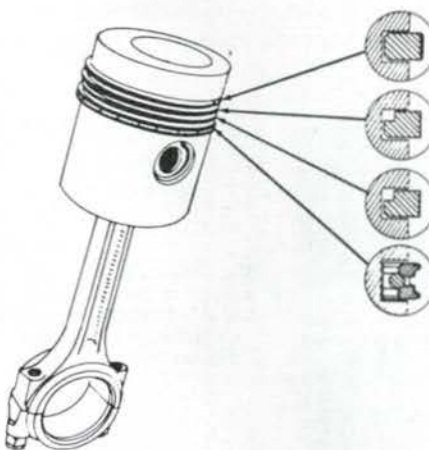

Fig. 74—Drawing of four-ring piston showing cross-section of rings correctly installed. Refer to text.

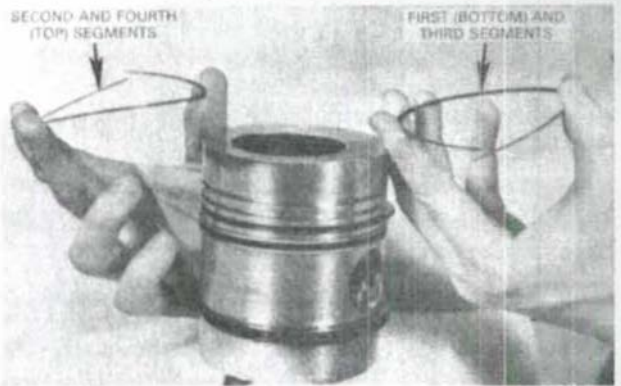

Fig. 73—The four-segment ring installed in the third groove of five-ring pistons must be correctly assembled as described in text.

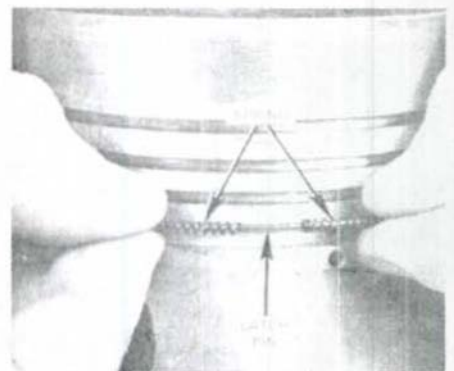

Fig. 75—The expander for oil controlling ring of four-ring piston must have the latch pin connecting ends of expander spring.



Ring End Gap—

Tbp .....	0.36-0.69 mm
	(0.014-0.027 in.)
Second & Third .....	0.28-0.61 mm
	(0.011-0.024 in.)
Bottom .....	0.25-0.74 mm
	(0.010-0.029 in.)

\* Skirt diameter measured at bottom of piston, 90° from piston pin bore.

On all models, check installed piston height at TDC when any new piston is installed (Fig. 76). Top of piston must be 0.10 mm (0.004 inch) above to 0.03 mm (0.001 inch) below top surface of cylinder block on all models except MF250. On Model MF250, piston installed height must be 0.03-0.15 mm (0.001-0.006 inch) below surface of cylinder block. If necessary, machine top of piston to obtain specified installed height.

Cylinder sleeves used in original production are 0.03-0.08 mm (0.001-0.003 inch) interference fit in cylinder block bores. Fit of service cylinder sleeves in cylinder block is from 0.03 mm (0.001 inch) tight to 0.03 mm (0.001 inch) loose. Original cylinder sleeve I.D. is 91.48-91.50 mm (3.6015-3.6025 inches). Sleeves should be renewed if cylinder bore taper exceeds 0.15 mm (0.006 inch) or if out-of-round is in excess of 0.10 mm (0.004 inch). A suitable sleeve removal and installing tool is required to renew sleeves.

Thoroughly clean and inspect cylinder block bores and sleeves before installing new sleeves, as even the slightest burr or dirt can cause distortion of new sleeve when pressed into the block. Lubricate cylinder bores with a thin lubricant prior to installing sleeves. Press sleeve into cylinder block bore until sleeve flange bottoms in cylinder block counterbore. When correctly installed, top of sleeve should be 0.10 mm (0.004 inch) above to 0.10 mm (0.004 inch) below top surface of block. Allow sleeve to stabilize, then check to be sure sleeve bore is not distorted and is the correct diameter.

Service sleeves are prefinished and should not require additional machining after installation. Correct installed cylinder bore diameter is 91.50-91.53 mm (3.6025-3.6035 inches).

PISTON PINS

All Diesel Models

74. The floating type piston pins are retained in piston bosses by snap rings. The piston pins are a transitional fit in piston; heating piston to 38°-49°C (100°-120°F) in oil or water will make removal and installation of pin easier. Piston pins are available in standard size only. Outside diameter of pin is 31.744-31.750 mm (1.2498-1.2500 inches). Inside diameter of connecting rod bushing should be 31.76-31.79 mm (1.2505-1.2515 inches). Desired pin to rod bushing diametral clearance is 0.04-0.10 mm (0.0018-0.0039 inch). Piston pin should have transition fit in piston bosses of 0.0 mm (0.0 inch) interference to 0.01 mm (0.0004 inch) clearance.

The renewable connecting rod bushing must be final sized after installation to provide recommended piston pin operating clearance. Be sure hole in bushing is properly aligned with oil hole in top of connecting rod when installing new bushing.

CONNECTING RODS AND BEARINGS

All Diesel Models

75. Connecting rod bearings are precision type, renewable from below after removing oil pan and bearing caps. When renewing bearing shells, be sure the projection engages milled slot in rod and cap and that the correlation numbers on rod and cap are in register and face away from camshaft side of engine. Replacement rods should be marked with the cylinder number in which they are installed. Bearings are

available in standard, as well as 0.25, 0.50 and 0.75 mm (0.010, 0.020 and 0.030 inch) undersizes.

Connecting rod bearing diametral clearance should be 0.06-0.10 mm (0.0025-0.0040 inch). Recommended connecting rod side clearance is 0.24-0.50 mm (0.010-0.020 inch).

Manufacturer recommends renewing connecting rod cap bolts and nuts whenever they are removed. Refer to paragraph 72 for tightening torque values.

CRANKSHAFT AND BEARINGS

All Diesel Models

76. The crankshaft is supported in four precision type main bearings. To remove crankshaft, drain engine oil. Remove engine as outlined in paragraph 56. Remove oil pan, timing gear cover and lower cover from timing gear case. Remove engine oil pump. Remove clutch, flywheel, engine adapter plate and crankshaft rear oil seal. Remove connecting rod bearing caps and main bearing caps, then lift crankshaft from cylinder block.

The upper and lower halves of the front main bearing insert are not interchangeable with other bearings or with each other. The four insert halves of the second and third main bearings are all alike. The upper and lower halves of the rear main bearing are alike, but not interchangeable with other bearing inserts. Main bearing inserts are available in standard size and 0.25, 0.50 and 0.75 mm (0.010, 0.020 and 0.030 inch) undersizes.

Crankshaft end play is controlled by renewable thrust washers at front and rear of rear main bearing. The cap half of thrust washer is prevented from turning by the tab which fits in a machined notch of cap. Block half of washer can be rolled from position when cap is removed. Recommended crankshaft end play is 0.05-0.38 mm (0.002-0.015 inch).

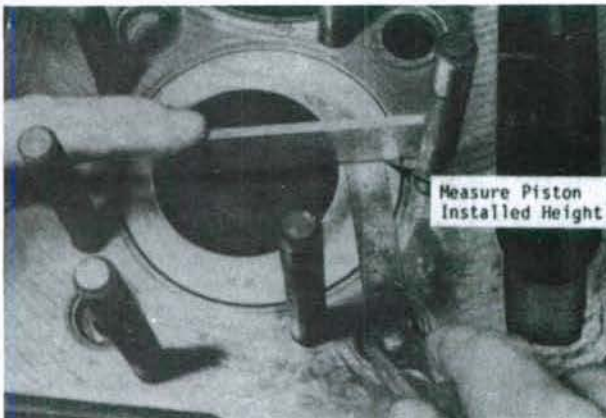

Fig. 76—Measure installed height of new pistons as shown. It may be necessary to machine piston crown to obtain desired height.

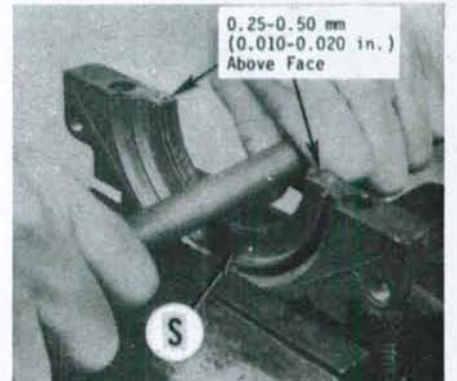

Fig. 77—Use a round bar to seat the rope seal into retainer half. The slot (S) is only in lower half of seal retainer. Do not trim ends of seal.

Thrust washers are available in 0.18 mm (0.007 inch) oversize as well as standard thickness. One set (top and bottom) of oversize thrust washers may be installed on one side (front or rear) in combination with standard size set at other side to provide oversize adjustment of 0.18 mm (0.007 inch). Two sets of oversize thrust washers may be used to provide adjustment of 0.36 mm (0.014 inch).

Crankshaft balance weights are available only in matched pairs because maximum variation between weights must be less than 28 grams (1 ounce). Tighten weight retaining cap screws to 68-75 N · m (50-55 ft.-lbs.) torque, then bend lock tabs to lock screws in place.

Check crankshaft against the standard sizes listed below:

<b>Main Journal</b>	
Diameter	69.81-69.83 mm (2.7485-2.7492 in.)
<b>Crankpin</b>	
Diameter	57.11-57.13 mm (2.2485-2.2492 in.)
<b>Main Bearing</b>	
Clearance—	
MF230, MF235, MF245	0.08-0.13 mm (0.003-0.005 in.)
MF240, MF250	0.05-0.10 mm (0.002-0.004 in.)
<b>Rod Bearing</b>	
Clearance	
	0.06-0.10 mm (0.0025-0.0040 in.)
<b>Crankshaft End</b>	
Play	0.05-0.38 mm (0.002-0.015 in.)

To reinstall crankshaft, reverse the removal procedure. Note that main bearing caps are numbered 1 through 4 with number 1 cap at front of engine. The caps are also marked with a serial number which corresponds with and must be in line with serial numbers stamped on bottom of cylinder block. Make certain thrust washers are installed with grooved side towards crankshaft. Tighten main bearing cap screws to 150 N · m (110 ft.-lbs.) torque.

**CRANKSHAFT REAR OIL SEAL**

**All Models So Equipped**

**77. ROPE TYPE SEAL.** The rope type rear oil seal is contained in a two-piece retainer attached to rear face of cylinder block. The rope seal is cut to correct length and should be installed in retainer halves with 0.25-0.50 mm (0.010-0.020 inch) of the seal protruding from each end of retainer. Do not trim ends of seal.

To install the seal, clamp each half of retainer in a vise as shown in Fig. 77. Make sure seal groove is clean. Start

each end of seal in groove with the specified amount of free end protruding. Allow seal rope to buckle in the center until about 25 mm (1 inch) of each end is bedded in groove, work center of seal into position, then roll with a round bar as shown. Repeat the process with the other half of seal.

Install seal retainer as follows: Clean sealing surfaces of block, bearing cap and seal retainers. Coat both sides of retainer gasket and end joints of retainer halves with a suitable gasket cement. Coat surface of ropeseal with engine oil. Assemble retainer halves around crankshaft and install cap screws loosely. Be sure that retainer half with oil return slot (S—Fig. 77) is toward bottom of engine. Tighten the two long cap screws with nuts to 8 N · m (6 ft.-lbs.) torque, then tighten cap screws to cylinder block and bearing to 16 N · m (12 ft.-lbs.). Finish by tightening the two long cap screws and nuts to final torque of 16 N · m (12 ft.-lbs.).

**All Models So Equipped**

**78. LIP TYPE SEAL.** The lip type rear oil seal is contained in a one-piece retainer which is attached to rear of cylinder block.

When renewing seal, inspect crankshaft flange for wear in seal contact area. If flange is grooved, seal should be pressed further into retainer so seal lip will contact area of flange that is not worn. The crankshaft seal surface may be machined, if necessary, to smooth seal surface.

Make certain seal is pressed squarely into retainer. Lubricate seal lip and crankshaft flange prior to installing seal. Tighten retainer cap screws to 18 N · m (14 ft.-lbs.) torque.

**FLYWHEEL**

**All Diesel Models**

**79.** To remove the flywheel, first separate the engine from transmission

housing and remove the clutch. Flywheel is secured to crankshaft flange by six evenly spaced cap screws. To properly time flywheel to engine during installation, be sure that unused hole in flywheel aligns with untapped hole in crankshaft flange.

**CAUTION:** Flywheel is only lightly piloted to crankshaft. Use caution when unbolting flywheel to prevent flywheel from falling and causing possible injury.

On some models, shims may be installed between the crankshaft and flywheel. Check for these shims upon disassembly to prevent loss or damage. Be sure shims are reinstalled when flywheel is installed.

The starter ring gear can be renewed after flywheel is removed. Heat new ring gear to 245°C (475°F). Do not overheat as gear heat treatment could be destroyed. Install gear on flywheel with beveled end of teeth facing forward. Allow gear to air cool.

Reinstall flywheel and tighten mounting cap screws to 106 N · m (78 ft.-lbs.) torque. Check flywheel runout with a dial indicator after flywheel is installed. Runout measured at machined surface of outer diameter must not exceed 0.30 mm (0.012 inch). Runout measured at clutch surface must not exceed 0.025 mm (0.001 inch) for each 25 mm (1 inch) from flywheel centerline to point of dial indicator measurement. If runout is excessive, remove flywheel and check for burrs or foreign material.

**OIL PAN**

**All Diesel Models**

**80.** The cast iron oil pan serves as part of tractor frame and as attaching point for tractor front support. To remove oil pan, first drain engine oil. Support tractor under transmission housing, then remove front axle and support housing assembly. Support oil pan, remove re-

*Fig. 78—The oil pump is attached to the front main bearing cap and is driven via idler gear by the crankshaft timing gear.*

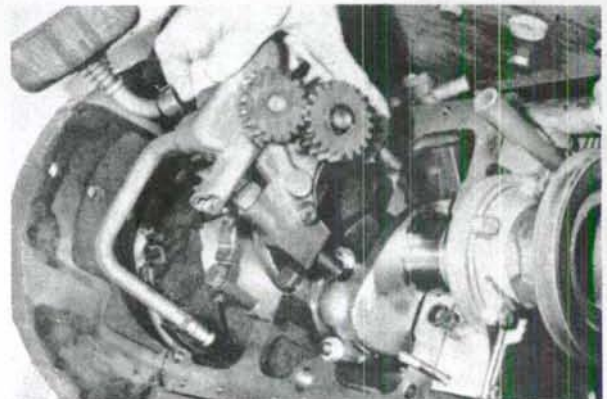

taining cap screws and lower pan from cylinder block.

To reinstall, reverse the removal procedure.

**OIL PUMP**

**All Diesel Models**

81. The rotary type oil pump is mounted on front main bearing cap and driven from the crankshaft timing gear through an idler as shown in Fig. 78.

To remove the oil pump, first remove oil pan as outlined in paragraph 80. Disconnect oil delivery pipe from cylinder block and oil suction pipe from main bearing cap. Unbolt and remove the front main bearing cap with oil pump attached. Pump can be unbolted from main bearing cap after removing idler gear.

Check rotor clearance with a feeler gage as shown in Fig. 79. Clearance should be 0.01-0.06 mm (0.0005-0.0025 inch). Outer rotor to body clearance (Fig. 80) should be 0.028-0.033 mm (0.011-0.013 inch). Inner rotor end clearance (Fig. 81) should be 0.04-0.08 mm (0.0015-0.0030 inch) and outer rotor end clearance should be 0.01-0.06 mm (0.0005-0.0025 inch). If pump rotor or body are worn, scored or damaged, pump assembly must be renewed.

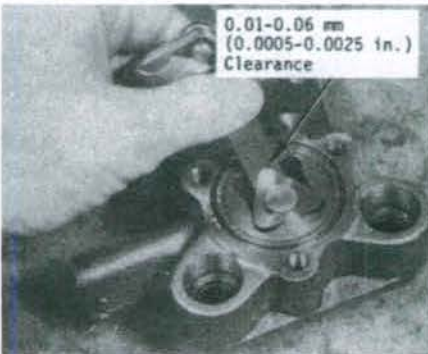

Fig. 79—Clearance between inner and outer rotors can be measured using a feeler gage as shown.



Fig. 80—Clearance between outer rotor and pump body can be measured as shown.

Remove oil pressure relief valve spring and plunger from pump body. Inspect plunger and bore in pump body for wear or scoring and renew if necessary. Oil pressure should be 345-445 kPa (50-65 psi) at high idle speed with engine at normal operating temperature.

If oil pump drive gear was removed, press gear onto shaft, with flat face of gear outward, until face of gear is flush with end of shaft.

Reinstall pump by reversing the removal procedure. Tighten main bearing cap screws to 150 N · m (110 ft.-lbs.) torque.

**COOLING SYSTEM**

**All Diesel Models**

82. **RADIATOR.** To remove radiator, first drain the cooling system. Remove hood and side panels. Remove radiator support strap. Remove fan shroud retaining screws and move shroud rearward. Disconnect top and bottom hoses from radiator. Remove cap screws attaching radiator to grille housing and remove the two retaining nuts from underneath front axle support. Lift radiator from the tractor.

To reinstall, reverse the removal procedure.

83. **THERMOSTAT.** The thermostat (17—Fig. 82) is contained in a housing under the coolant outlet elbow (18). Thermostat should begin to open at 81°84°C (177°183°F) and should be fully open at 98°C (208°F).

84. **WATER PUMP.** To remove water pump, first drain cooling system. On Models MF240 and MF250, remove radiator as outlined in paragraph 82. On all models, remove fan and fan belt. Disconnect hoses from pump, remove pump mounting cap screws and remove pump assembly.

To disassemble, remove back cover plate (9—Fig. 82). Remove pulley hub (1)

using a suitable puller. Press shaft and bearing assembly (2) with impeller (7) rearward from pump housing. Press shaft out of the impeller. Remove seal assembly (6) and slinger (3).

Inspect all parts for wear or damage and renew if necessary. Be sure to renew seal assembly.

To reassemble, press shaft and bearing assembly into housing until front face of bearing is flush with front of housing. Be sure shorter end of shaft is towards front of housing. Install slinger (3) with flange towards bearing assembly. Install front part of seal with carbon face of seal facing rearward as shown in Fig. 83. Install ceramic faced seal with grooved side towards the impeller. Support front end of shaft, then press impeller onto shaft until clearance between front of impeller blades and pump housing is 0.25-0.50

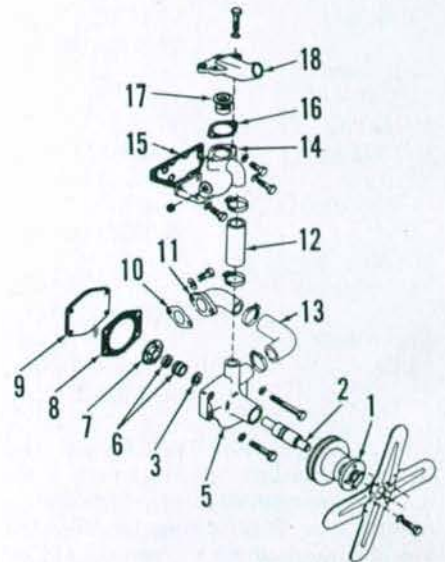

Fig. 82—Exploded view of water pump end thermostat housing.

- 1. Pulley flange
- 2. Shaft & bearing
- 3. Slinger
- 4. Housing
- 5. Seal assy.
- 6. Impeller
- 7. Gasket
- 8. Back cover plate
- 9. Gasket
- 10. Gasket
- 11. Elbow
- 12. Bypass hose
- 13. Outlet hose
- 14. Thermostat housing
- 15. Gasket
- 16. Gasket
- 17. Thermostat
- 18. Elbow



Fig. 81—Use a straightedge and feeler gage to measure end clearance between top of rotors and machined surface of pump body.



Fig. 83—Install front part of seal with carbon face toward rear. The ceramic counterface should be installed with grooved side toward rear.

mm (0.010-0.020 inch). Support rear end of shaft (not the impeller), place pump mounting cap screws into holes in housing, then press pulley hub onto shaft as shown in Fig. 84. Distance (A) from gasket surface to fan surface of pulley flange should be 140.5 mm (5.530 inches). Make certain shaft assembly rotates smoothly.

Reinstall water pump by reversing the removal procedure. Adjust fan belt tension to provide 13-19 mm (1/2 to 3/4 inch) deflection with 66 N (15 pounds) force applied midway between longest span between pulleys.

## DIESEL FUEL SYSTEM

The diesel fuel system consists of three basic units; the fuel tank and filters, injection pump and injector nozzles. When servicing any unit associated with the diesel fuel system, the maintenance of absolute cleanliness is of utmost importance. Of equal importance is the avoidance of nicks or burrs on any of the working parts.

### FUEL FILTERS

#### All Models So Equipped

85. Models MF230, MF235 and MF245 are equipped with a single fuel filter (F—Fig. 85). Two fuel filters, a primary and secondary, are used on Models MF240 and MF250. A glass sediment bowl is located at the bottom of the primary or single filter element. Bowl should be inspected and any dirt or water accumulation drained daily. If substantial amount of water or other contamination is evident, source of contamination should be found and corrected.

Manufacturer recommends renewing fuel filter element(s) after every 500 hours of operations or annually, whichever comes first. Filter elements should also be renewed if loss of engine power or uneven running is noticeable regardless of hours of operation. Note that cleanliness of fuel supply has more effect on the life of fuel filters than hours of operation.

Thoroughly clean fuel filter and surrounding area prior to removal. Close fuel tank shut-off valve. Remove center cap screw from fuel filter head and remove filter element. Install new element using new gaskets. Open fuel shut-off valve and bleed air from system as outlined in paragraph 86.

Fig. 84—Distance (A) should be 140.5 mm (5.530 inches). Be sure to support end of shaft (not the impeller) and install mounting cap screws before pressing pulley hub onto shaft.

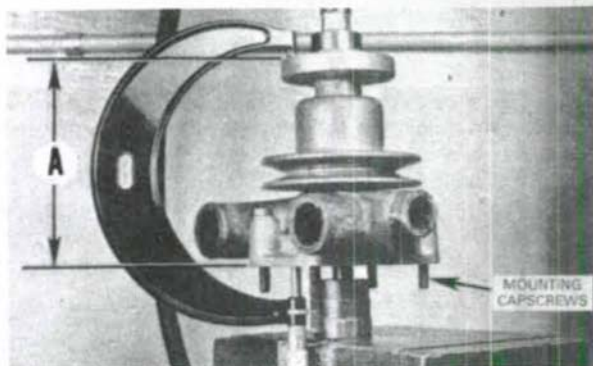

### BLEEDING FUEL SYSTEM

#### All Models So Equipped

86. To bleed air from fuel system, first make sure fuel shut-off valve is open and move injection pump shut-off control to "Run" position. Loosen air vent plug (1—Fig. 85) in top of filter head, then operate lift pump priming lever until air-free fuel flows from vent. Tighten vent plug.

**NOTE:** It may be necessary to rotate crankshaft to change position of camshaft lobe in relation to lift pump actuating arm to allow operation of priming lever.

Loosen vent plug on secondary filter (if so equipped) and repeat bleeding procedure. Open vent plugs (2 and 3) on injection pump and operate lift pump priming lever. Tighten lower plug then upper plug as air-free fuel flows from each vent. Note that air in governor housing relieved by bleed screw (3) will not prevent engine from starting and running properly; however, condensation in the trapped air can cause rusting of governor components and eventual pump malfunction.

Loosen Thermostart fuel supply line (tractors so equipped) at intake manifold and operate lift pump priming lever until fuel flows from the line. Retighten fuel line connection. If engine fails to start at this point, loosen high pressure fuel line connections at injectors. With hand throttle in full speed position, crank engine with starter motor until fuel flows from the connections. Retighten fuel line connections and start engine.

### THERMOSTART SYSTEM

#### All Models So Equipped

87. The Thermostart system is available as an aid for cold weather starting on late production MF250 tractors. The system consists of an electrically actuated heater located in the intake manifold. The unit heats and ignites diesel fuel vapor in intake manifold to warm the air going into the cylinders.

The system is actuated by turning the starter switch to "Heat" position for 15 to 20 seconds, then turn key to "Heat/Start" position and crank engine. After engine starts, key can be returned to "Heat" position until engine runs smoothly or for a maximum of 15

Fig. 85—Schematic view of typical diesel fuel system showing direction of fuel flow in fuel lines, filter (F), lift pump (L) and injection pump (P). Line (R) returns excess fuel to tank. Two filters are used on MF240 and MF250.

1. Filter bleed plug
2. Pump bleed plug
3. Governor housing bleed plug

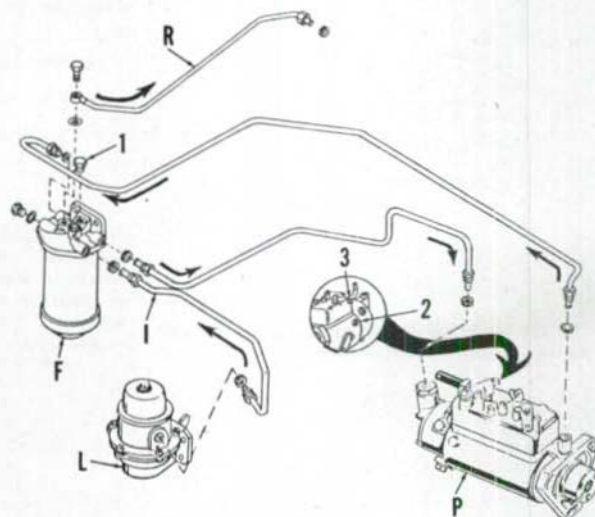

seconds. Release the key when engine is running smoothly.

**CAUTION:** Never spray ether into air intake system if Thermostart unit will be or has been activated. Premature combustion of ether in manifold or cylinder head can result causing severe engine damage or personal injury.

If Thermostart unit does not operate properly, check for voltage at intake manifold wiring connector while holding key switch in "Heat" position. If voltage is not present, check wiring and switch.

If voltage is reaching Thermostart unit, disconnect fuel line and check for restricted fuel flow. If fuel is flowing to Thermostart unit, remove the unit, inspect and renew as necessary.

**FUEL LIFT PUMP**

**All Models So Equipped**

88. The fuel lift pump shown in Fig. 86 is operated by an eccentric on the engine camshaft. Output delivery pressure should be 41-69 kPa (6-10 psi).

Scribe marks across cover (16) and body (11) before disassembling to ensure correct alignment when reassembling.

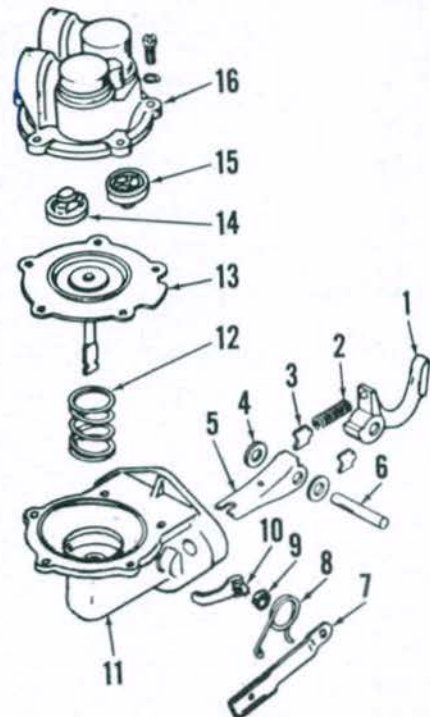

Fig. 86—Exploded view of fuel lift pump. Check valves (14 and 15) are available only with cover (16).

- |                    |                        |
|--------------------|------------------------|
| 1. Rocker arm      | 9. Washer              |
| 2. Spring          | 10. Internal lever     |
| 3. Retainers       | 11. Body               |
| 4. Washers         | 12. Spring             |
| 5. Connecting link | 13. Diaphragm          |
| 6. Pin             | 14. Outlet check valve |
| 7. Priming lever   | 15. Inlet check valve  |
| 8. Spring          | 16. Cover              |

Diaphragm (13) is disconnected from lever (5) by pushing it into pump body and turning it 90°. A repair kit containing check valves (14 and 15), diaphragm (13) and actuating link (5) components is available for servicing lift pump.

Bleed air from system as outlined in paragraph 86 after reinstalling pump.

**INJECTOR NOZZLES**

All diesel models are equipped with C.A.V. multihole nozzles which extend through the cylinder head to inject the fuel charge directly into combustion chamber. Different injectors have been used. Refer to identification code letters (Fig. 87) stamped on nozzle holder when servicing injectors. Do not intermix different types of injectors.

**All Models So Equipped**

**89. LOCATING FAULTY NOZZLE.**

If rough or uneven engine operation or misfiring indicates a faulty injector, the defective unit can usually be located as follows: With engine running at the speed where malfunction is most noticeable, loosen the compression nut on high pressure line for each injector in turn so fuel is discharged at the loosened connection. Note change in engine, if any, and retighten connection. The faulty unit is the one which least affects the running of engine when its line is loosened. If a faulty nozzle is found and considerable time has elapsed since the injectors have been serviced, it is recommended that all nozzles be removed and serviced or that new or reconditioned units be installed. Refer to the following paragraphs for removal and test procedure.

**90. REMOVE AND REINSTALL.**

Before loosening any fuel lines, thoroughly clean the lines, connections, injectors and engine area surrounding the injector with air pressure and solvent spray. Disconnect the fuel leak-off line and pressure line from the injector. Cap

all connections as they are loosened to prevent dirt entry into the system. Remove the two stud nuts and withdraw injector unit from the cylinder head. Thoroughly clean the nozzle recess in cylinder head before reinstalling injector unit. It is important that seating surface be free of even the smallest particle of carbon or dirt which could cause the injector unit to be cocked and result in blowby. No hard or sharp tools should be used in cleaning.

Do not reuse the copper sealing washer (Fig. 87) located between injector nozzle and cylinder head, always install a new washer. Be sure only one copper sealing washer is in place when installing the injector. Each injector should slide freely into place in cylinder head without binding. Make sure dust seal is reinstalled and tighten the retaining stud nuts evenly to a torque of 14-16 N·m (10-12 ft.-lbs.).

91. TESTING. A complete job of testing and adjusting the injector requires the use of special test equipment. Only clean, approved testing oil should be used in the test tank. The nozzle should be tested for opening pressure, seat leakage, back leakage, and spray pattern. When tested, the nozzle should open with a sharp popping or buzzing sound and cut off quickly at end of injection with a minimum of seat leakage and controlled amount of back leakage.

**WARNING:** Fuel leaves the injector nozzle tip with sufficient force to penetrate the skin. Keep protected parts of your body clear of nozzle spray when testing.

Before conducting test, operate tester lever until fuel flows from tester line, then attach the injector. Pump tester lever a few quick strokes to clear air from tester line and injector and to make sure nozzle valve is not stuck or spray holes plugged.

92. OPENING PRESSURE. Open valve to tester gage and operate tester

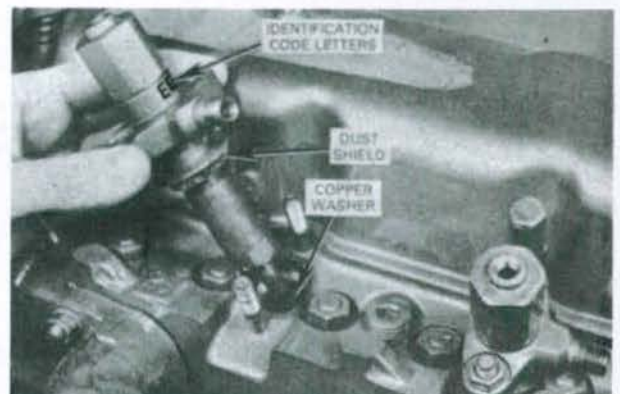

Fig. 87—Different injectors have been used. Identification code letters are stamped in location shown. Always use new copper sealing washer and be sure that only one is installed.

lever slowly while observing gage reading. Opening pressure should be as follows:

**Nozzle Identification**

Code .....	EE
Setting Pressure With	
New Spring .....	19235 kPa (2790 psi)
Normal Operating	
Pressure .....	17720 kPa (2570 psi)

**Nozzle Identification**

Code .....	DN or FS
Setting Pressure With	
New Spring .....	18755 kPa (2720 psi)
Normal Operating	
Pressure .....	17240 kPa (2500 psi)

**Nozzle Identification**

Code .....	GM
Setting Pressure With	
New Spring .....	18755 kPa (2720 psi)
Normal Operating	
Pressure .....	17720 kPa (2570 psi)

If opening pressure is not as specified, remove the injector cap nut (1—Fig. 90) and turn adjusting screw (3) as required to obtain recommended pressure.

**NOTE:** When adjusting a new injector or overhauled injector with new pressure spring (4), set pressure to the recommended higher pressure to allow for initial pressure loss due to spring taking a set.

93. SEAT LEAKAGE. To check for leakage at nozzle valve seat, wipe nozzle tip dry.



Fig. 88—Nozzle holes (arrows) are not located an equal distance from nozzle tip.

Operate tester lever slowly to maintain gage pressure at 1000 kPa (150 psi) below nozzle opening pressure. Hold test pressure for 10 seconds; if fuel appears on nozzle tip, the valve is not seating and injector must be overhauled or renewed.

94. BACK LEAKAGE. If no external leakage was noted in seat leakage test, check for back leakage as follows: Bring gage pressure to about 16000 kPa (2300 psi), close tester return valve and release tester lever. Observe the time required for gage pressure to drop from 15170 kPa (2200 psi) to 10135 kPa (1470 psi). For a nozzle in satisfactory condition, this time should not be less than six seconds. A faster pressure drop indicates a worn or scored nozzle valve assembly, and nozzle valve should be renewed.

**NOTE:** Leakage of the tester check valve or connections will cause a false reading, showing up in this test as excessively fast leak-back. If all injectors tested fail to pass this test, the tester rather than the units should be suspected as faulty.

95. SPRAY PATTERN. If leakage and pressure are as specified when tested as outlined in previous paragraphs, operate tester handle several times while observing spray pattern. Four finely atomized, conical sprays should emerge from nozzle tip with equal penetration into surrounding atmosphere.

**NOTE:** Spray pattern is not symmetrical with centerline of nozzle tip. The apparently irregular location of nozzle holes (See Figs. 88 and 89) is designed to provide the correct spray pattern in the combustion chamber.

If pattern is uneven, ragged or not finely atomized, overhaul the nozzle as outlined in paragraph 96.

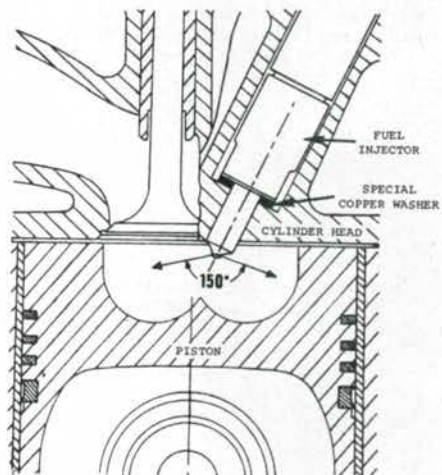

Fig. 89—Cutaway view of combustion chamber showing injector spray angle relative to engine.

96. OVERHAUL. Hard or sharp tools, emery cloth, grinding compound, or other than approved solvents or lapping compounds must never be used. An approved nozzle cleaning kit is available through any C.A.V. Service Agency and other sources.

Wipe all dirt and loose carbon from exterior of nozzle and holder assembly. It is recommended that injectors be soaked in a suitable carbon cleaning solution for several hours, or overnight if possible, prior to disassembly; otherwise, nozzle valve body (9—Fig. 90) may turn with nozzle nut (10) shearing the locating dowel pins (7).

Secure nozzle holder (6) in a soft-jawed vise or holding fixture, then remove cap nut (1). Remove adjusting screw (3), spring (4) and spindle (5). Unscrew nozzle nut (10) and remove nozzle valve assembly (8 and 9).

Nozzle valve (8) and body (9) are matched assemblies and must not be intermixed. If more than one injector is to be disassembled, keep parts of each injector separate from the others by placing in a compartmented pan containing clean diesel fuel.

Clean injector exterior using a brass wire brush. Soak in a suitable carbon solvent, if necessary, to loosen hard carbon deposits. Rinse parts in clean diesel fuel or calibrating oil after cleaning to neutralize the carbon solvent and pre-

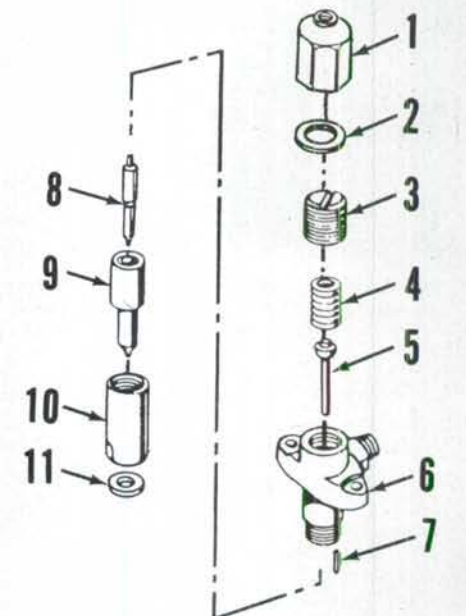

Fig. 90—Exploded view of typical C.A.V. injector nozzle and holder assembly.

- |                    |                   |
|--------------------|-------------------|
| 1. Cap nut         | 7. Dowel pin      |
| 2. Gasket          | 8. Nozzle valve   |
| 3. Adjusting screw | 9. Nozzle body    |
| 4. Spring          | 10. Nozzle nut    |
| 5. Spindle         | 11. Copper washer |
| 6. Nozzle holder   |                   |

vent etching of polished surfaces. Use a pin vise with correct size cleaning wire to clean nozzle spray holes as shown in Fig. 91. Cleaning wire should be slightly smaller than spray holes. On nozzles with "EE" identification code, spray hole diameter is 0.28-0.30 mm (0.011-0.012 inch). On all other nozzles, spray hole diameter is 0.25-0.27 mm (0.010-0.0105 inch). Clean nozzle body seat and fuel passages using appropriate tools from cleaning kit.

All polished surfaces should be relatively bright without scratches or dull patches. Nozzle valve (8—Fig. 90) must slide freely in valve body (9). If valve sticks, reclean or renew valve assembly as necessary.

Before reassembling, thoroughly rinse all parts in clean diesel fuel and make sure all carbon deposits have been

removed. Assemble parts while wet with diesel fuel. Tighten nozzle nut to 68 N · m (50 ft.-lbs.) torque.

Retest and adjust the assembled injector as outlined in paragraphs 91 through 95.

**INJECTION PUMP**

The injection pump is a sealed unit and no service work of any kind should be attempted on the pump or governor unit without the use of special pump testing equipment and special training. The only authorized adjustment is of the low idle speed screw (Fig. 93). If additional service work is required, the pump should be turned over to an authorized C.A.V. service station for overhaul. Inexperienced or unequipped service personnel should never attempt to overhaul a diesel injection pump.

**All Models So Equipped**

**97. ADJUSTMENT.** The low idle speed adjusting screw (Fig. 93) should be adjusted with engine warm and running, to provide the recommended slow idle speed of 725-775 rpm.

Check to make sure that governor arm contacts the low idle adjusting screw and

maximum speed adjusting screw when throttle lever is moved to slow and fast positions. Also check to make sure stop lever moves fully to operating position when stop button is pushed in, and shuts off fuel to injectors when stop button is pulled.

The maximum speed adjusting screw (Fig. 93) is set at the factory and the adjustment is sealed. High idle (no-load) speed should be 2135-2185 on Models MF230 and MF240, 2400-2450 on Models MF235, MF245 and MF250.

**98. PUMP STATIC TIMING.** To check pump timing, shut off fuel at fuel tank. Remove timing window cover (C—Fig. 98) from injection pump and remove engine timing window plug from left side of flywheel housing adapter plate. Turn crankshaft until No. 1 (front) piston is coming up on compression stroke and the correct degree mark for static timing is aligned in flywheel timing window (Fig. 94); 16° BTDC for MF245 and MF250, 24° BTDC for MF230, MF235 and MF240. At this point the "E" mark on injection pump rotor should align with square end of snap ring as shown in Fig. 95.



Fig. 91—Clean spray holes in nozzle tip using a pin vise and correct size cleaning wire. Refer to text.



Fig. 92—Make sure lapped pressure faces of nozzle valve and holder are clean and free of nicks or scratches.

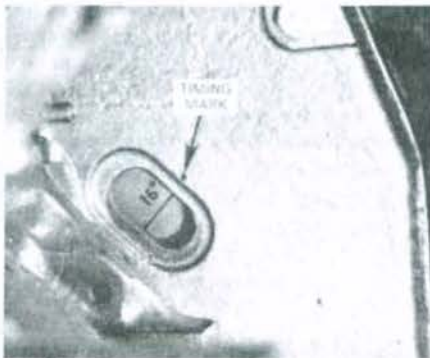

Fig. 94—View of flywheel 16° BTDC mark aligned with timing mark of flywheel housing. The 16° mark is used for timing MF245 and MF250 tractors. Use 24° mark for all other models.

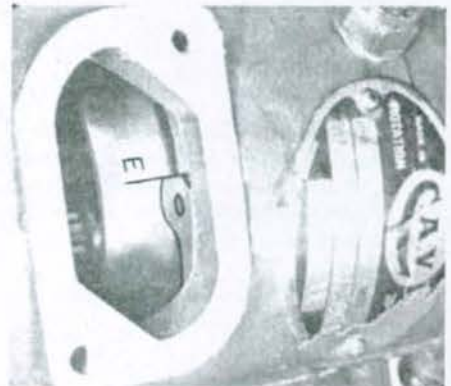

Fig. 95—The "E" timing mark on injection pump rotor should align with square end of snap ring when flywheel timing mark is aligned as shown in Fig. 94.

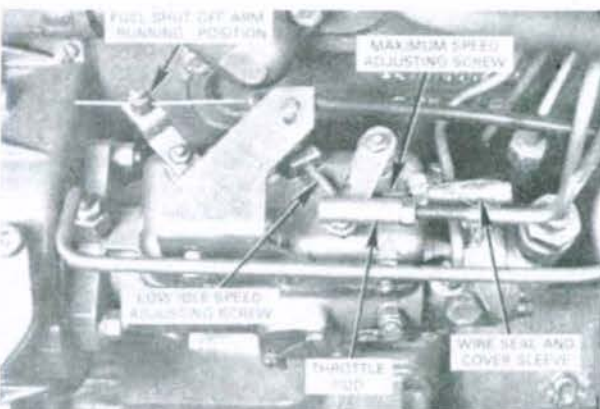

Fig. 93—View of injection pump showing points of adjustment.

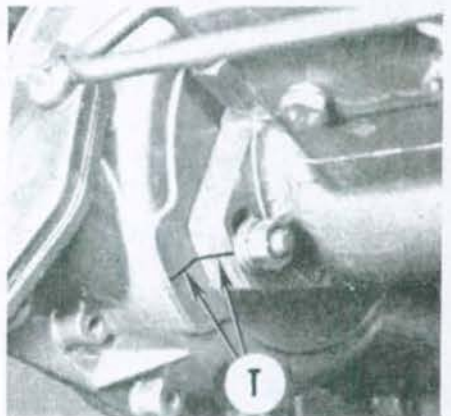

Fig. 96—Timing marks (T) should be aligned when pump is reinstalled.

If "E" mark is slightly out of alignment with end of snap ring, the mounting holes in pump flange are elongated to permit minor timing variations. If it is necessary to move pump, check alignment of timing marks on pump flange and timing gear case (Fig. 96) and scribe new lines as necessary. If "E" mark cannot be aligned by shifting pump on mounting studs, either the No. 1 piston is not on compression stroke or engine timing gears are not timed correctly.

**99. REMOVE AND REINSTALL.** The injection pump drive shaft has a milled slot (S—Fig. 98) in forward end which engages the dowel pin (D—Fig. 97) in pump drive gear. The injection pump drive gear cannot become unmeshed from idler gear with timing gear cover in place. Therefore, injection pump can be removed and reinstalled without regard to timing position.

Before removing the injection pump, thoroughly wash the pump and fuel line connections. Immediately plug all openings in fuel system as lines are disconnected to prevent entry of dirt. Disconnect throttle rod (Fig. 93) and stop cable or rod from pump. Shut off fuel, then disconnect fuel inlet, return and high pressure lines from pump. Remove inspection cover from front of timing gear cover, then remove three cap screws attaching injection pump drive gear to pump shaft. Remove pump flange stud nuts, then withdraw pump.

To reinstall pump, align milled slot (S—Fig. 98) in pump shaft with dowel (D—Fig. 97) and insert pump. Align timing marks (T—Fig. 96) on pump flange

Fig. 97—To remove injection pump, it is first necessary to remove inspection cover and remove three retaining cap screws from drive gear. Dowel (D) engages slot in pump shaft (Fig. 98).

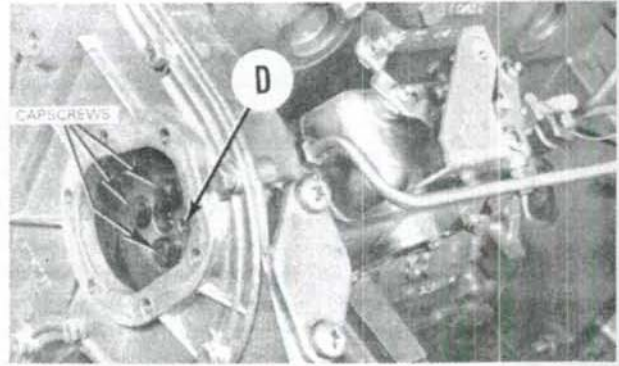
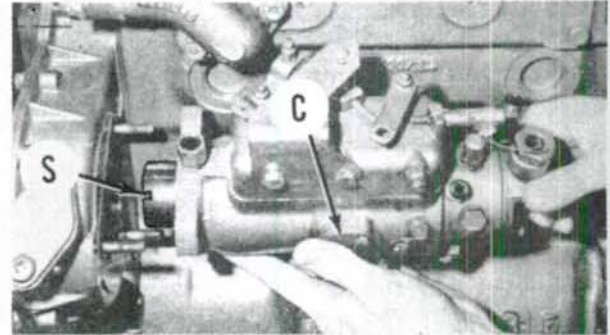

Fig. 98—Locating slot (S) must align with dowel (D—Fig. 97) when pump is reinstalled. Pump timing window cover is shown at (C).



and timing gear case, then tighten stud nuts.

**NOTE:** Pump can only be installed in one position. If timing gear train has not been disturbed and timing marks (T—Fig. 96) are aligned, timing should be correct.

Complete installation by reversing the removal procedure. Check pump timing as outlined in paragraph 98. Bleed air from system as outlined in paragraph 86.

**1100578**

Field Current	
Amperes	4.0-4.5
Volts	12
Cold Output	
Amperes at 2000 rpm	22
Amperes at 5000 rpm	33
Rated Hot Output (Amperes) at Maximum Operating Speed	37

**1100583**

Field Current	
Amperes	4.0-4.5
Volts	12
Cold Output	
Amperes at 2000 rpm	25
Amperes at 5000 rpm	37
Rated Hot Output (Amperes) at Maximum Operating Speed	42

To test alternator output while installed on tractor, first disconnect battery ground cable. Connect a test ammeter and voltmeter in circuit at alternator "BAT" terminal as shown in Fig. 99. Connect a carbon pile across battery as shown and turn on headlights. With engine operating at moderate speed, adjust carbon pile as required to obtain maximum current output. Voltage should be approximately 14.5 volts.

If ampere output is within 10 amperes of rated output stamped on alternator frame, alternator is not defective. If output is not within 10 amperes of rated output, ground field winding by inserting a screwdriver into test hole (Fig. 100) in rear of alternator. If output is now

## ELECTRICAL SYSTEM

100. The electrical system on all models is 12 volt, negative grounded system. Models MF230, MF235 and MF245 are equipped with Delco-Remy alternator and starter motor. Models MF240 and MF250 may be equipped with either Lucas or Perkins (Hitachi) alternator and starter motor.

Before any electrical system service is performed, a thorough check of condition of battery, cable connections, alternator drive belt and pulleys should be made. Always disconnect battery leads before performing any service operations on the tractor electrical system. Do not connect or disconnect any part of charging system while the engine is running as damage to voltage regulator could result. When connecting battery leads,

booster battery or battery charger, be sure to observe correct polarity (positive to positive, negative to negative). Do not short across or ground any terminals on alternator. Do not attempt to polarize alternator.

Refer to appropriate Figs. 247 through 250 for tractor wiring diagrams.

### ALTERNATOR AND REGULATOR

#### Models MF230-MF235-MF245

101. **TESTING.** A Delco-Remy alternator with integral solid state regulator is used on these tractors. Both 37 amp and 42 amp alternators are available, so be sure of model when testing. Refer to the following specifications:



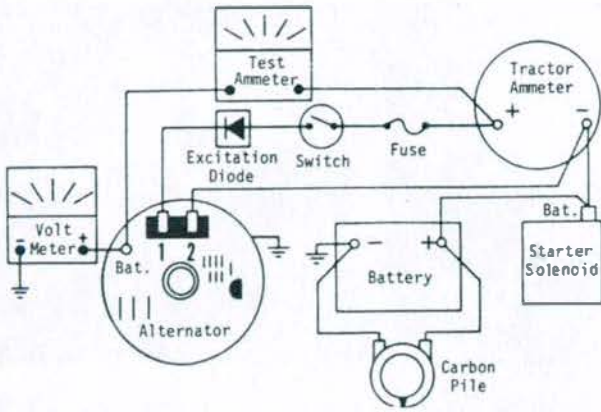

Fig. 99—Connect test ammeter and voltmeter in circuit at "BAT" terminal as shown to check output of Delco-Remy alternator. Refer to text.

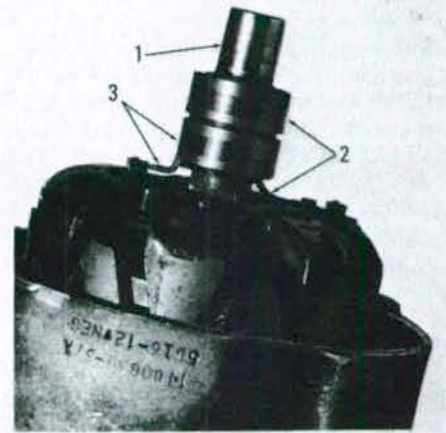

Fig. 102—Removed rotor assembly showing test points to be used when checking for grounds, shorts end opens.

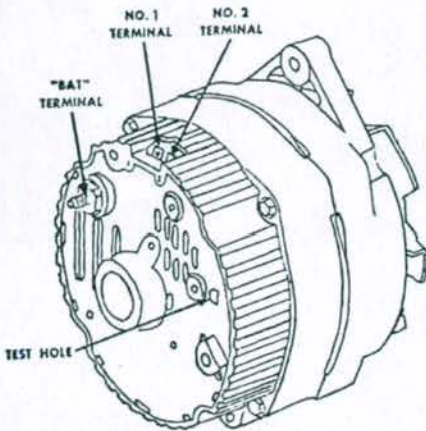

Fig. 100—View showing terminals and test hole on Delco-Remy alternator.

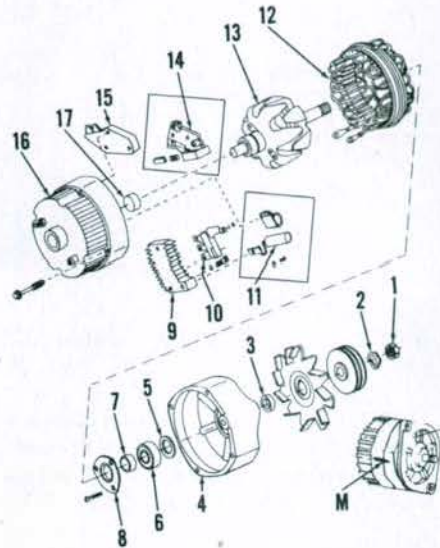

Fig. 101—Exploded view of Delco-Remy alternator with internal mounted solid-state regulator. Note match marks (M) on end frames.

- |                               |                           |
|-------------------------------|---------------------------|
| 1. Pulley nut                 | 9. Bridge rectifier       |
| 2. Washer                     | 10. Diode trio            |
| 3. Spacer (outside drive end) | 11. Capacitor             |
| 4. Drive end frame            | 12. Stator                |
| 5. Grease slinger             | 13. Rotor                 |
| 6. Ball bearing               | 14. Brush holder          |
| 7. Spacer (inside drive end)  | 15. Solid-state regulator |
| 8. Bearing retainer           | 16. Slip ring end frame   |
|                               | 17. Bearing & seal Assy   |

between stator frame (12) and drive end frame (4). Stator assembly (12) must remain with slip ring end frame (16) when unit is separated.

**NOTE:** When frames are separated, brushes will contact rotor shaft at bearing area. Brushes **MUST** be cleaned of lubricant if they are to be reused.

Clamp the iron rotor (13) in a protected vise only tight enough to permit loosening of pulley nut (1). Rotor end frame can be separated after pulley and fan are removed. Check bearing surface of rotor shaft for visible wear or scoring. Examine slip ring surface for scoring or wear, and rotor winding for overheating or other damage. Check rotor for grounded, shorted or open circuits using an ohmmeter as follows:

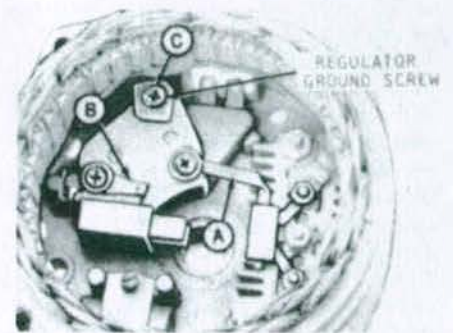

Fig. 103—Test points for brush holder, refer to text.

Refer to Fig. 102 and touch the ohmmeter probes to points (1-2) and (1-3); a reading near zero will indicate a short circuit to ground. Touch ohmmeter probes to the slip rings (2-3); reading should be 5.3-5.9 ohms. A higher reading will indicate an open circuit and a lower reading will indicate an internal short. If windings are satisfactory, mount rotor in a lathe and check runout at slip rings using a dial indicator. Runout should not exceed 0.05 mm (0.002 inch). Slip ring surfaces can be trued if runout is excessive or if surfaces are scored. Finish with 400 grit or finer polishing cloth until scratches or machine marks are removed.

Before removing stator, brushes or diode trio, refer to Fig. 103 and check for grounds between points A and C and B to C with an ohmmeter using the lowest range scale. Then reverse the lead connections. If both A to C readings or both B to C readings are the same, the brushes may be grounded because of defective insulating washer and sleeve at the two screws. If the screw assembly is not damaged or grounded, the regulator is defective.

To test the diode trio, first remove the stator. Then remove the diode trio, noting the insulator positions. With an

within 10 amperes of rated output, renew regulator and check field (rotor) winding as outlined in paragraph 102. If output is still not within 10 amperes of rated output, disassemble alternator and check field winding, diode trio, rectifier bridge and stator as outlined in paragraph 102.

If alternator fails to start charging at all, there may be an open circuit in wiring to No. 1 terminal of alternator. Voltage must be present at this terminal to provide initial excitation of field winding to start alternator charging. A quick field check for an open excitation circuit is to momentarily place a jumper wire between alternator "BAT" terminal and No. 1 terminal with engine running. If alternator starts charging, when it would not without jumper, an open excitation diode (located in wiring harness), oil pressure switch (diesel models), or ignition switch (gasoline models) is indicated.

**102. OVERHAUL.** To disassemble the alternator, first scribe matching marks (M—Fig. 101) on the two frame halves (4 and 16), then remove the four through-bolts. Pry frame apart with a screwdriver

ohmmeter, check between points A and D (Fig. 104) and then reverse the ohmmeter lead connections. If diode trio is good, it will give one high and one low reading. If both readings are the same, the diode trio is defective. Repeat this test at points B and D and at C and D.

The rectifier bridge (Fig. 105) has a grounded heat sink (A) and an insulated heat sink (E) that is connected to the output terminal. Connect ohmmeter to the grounded heat sink (A) and to the flat metal strip (B). Then reverse the ohmmeter lead connections. If both readings are the same, the rectifier bridge is defective. Repeat this test between points A and C, A and D, B and E, C and E, and D and E. Capacitor (11—Fig. 101) connects to the rectifier bridge and grounds to end frame, and protects the diodes from voltage surges.

Test the stator windings for grounded or open circuits as follows: Connect ohmmeter leads successively between each pair of leads. A high reading would indicate an open circuit. The three stator leads have a common connection in the center of the windings. Connect ohmmeter leads between each stator lead and stator frame. A very low reading would indicate a grounded circuit. A short circuit within the stator windings cannot be readily determined by test because of the low resistance of the windings.

Brushes and springs are available only as an assembly which includes brush holder (14—Fig. 101). If brushes are reused, make sure all grease is removed from surface of brushes before unit is reassembled. When reassembling, first install regulator and then brush holder, springs and brushes. Push brushes up against spring pressure and insert a short piece of straight wire through hole in brush holder and through end frame to outside. Be sure that the two screws

at points A and B (Fig. 103) have insulating washers and sleeves.

**NOTE: A ground at these points will cause no output, or uncontrolled output.**

Remove and inspect ball bearing (6—Fig. 101). If bearing is in satisfactory condition, fill bearing  $\frac{1}{4}$  full with Delco-Remy Lubricant No. 1948791 and reinstall. Inspect needle bearing (17) in slip ring end frame. This bearing should be renewed if its lubricant supply is exhausted; no attempt should be made to relubricate and reuse the bearing. Press old bearing out toward inside and press new bearing in from outside until flush with outside of end frame. Saturate felt seal with SAE 20 oil and install seal.

Reassemble alternator by reversing the disassembly procedure. Remove wire retaining the brushes after end frames are bolted together. Tighten pulley nut to a torque of 68 N·m (50 ft.-lbs.).

**Models MF240-MF250 With Lucas Alternator**

103. **TESTING.** To check alternator wiring harness continuity, disconnect wiring connections from alternator and turn start switch to auxiliary position. Connect a voltmeter between ground and each of the disconnected leads. Battery voltage should be present at the alternator “+” (battery) lead and the “IND” (warning light) lead. A zero

reading indicates open circuit in wiring or faulty warning light bulb. If an additional ground lead is used on alternator, check continuity of lead using an ohmmeter.

If voltage is present at “+” and “IND” leads, but warning light fails to come on when leads are reconnected to alternator, a faulty regulator and/or field (rotor) winding is indicated.

To check alternator output, first disconnect battery ground cable. Disconnect wiring from alternator, remove cover from rear of alternator, then reconnect wiring leads. Connect an ammeter between starter solenoid terminal and alternator output terminal (Fig. 106). Connect a voltmeter between output terminal and ground. Connect a carbon pile across battery terminals. Reconnect battery ground cable and start engine. Operate engine at 2000 rpm, turn on headlights and adjust carbon pile as required to obtain maximum current output. Ammeter reading should be approximately 34 amperes. Adjust carbon pile so ammeter reading is less than 10 amperes. Voltmeter reading should be within range of 13.6-14.4 volts.

If output is low, use a jumper lead to short together the “F” and “-” connections (Fig. 106) on alternator. If output is now within specified range, a faulty regulator and/or field winding is indicated. If output is still low, fault is elsewhere in alternator. Disassemble and check as outlined in paragraph 104.

104. **OVERHAUL.** To disassemble alternator, first remove rear cover (17—Fig. 107). Disconnect and remove surge protection diode, regulator (16) and brush holder (13) with brushes (12). Note that these parts can be removed without removing the alternator from the engine. Any further disassembly of alternator will require removal of alternator.

Scribe match marks on slip ring housing (11), stator frame (10) and drive end frame (3) to ensure correct alignment for reassembly. Unsolder stator wires from

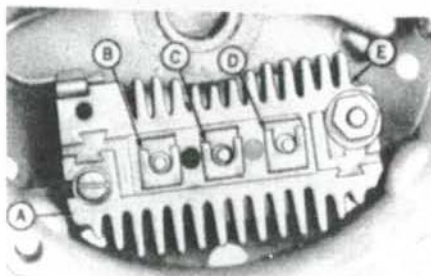

Fig. 105—Bridge rectifier test points, refer to text.

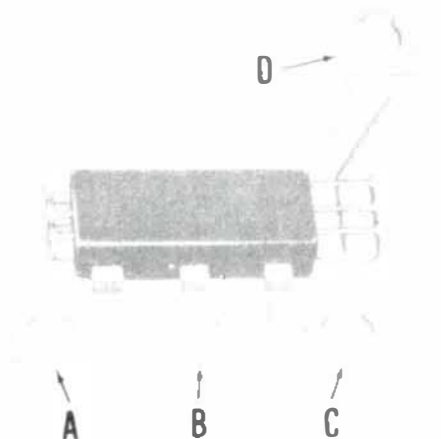
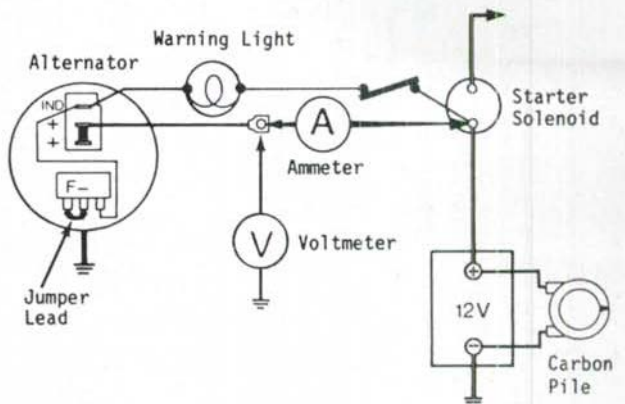

Fig. 104—Diode trio test points, refer to text.

Fig. 106—Connect test ammeter and voltmeter as shown to check alternator output on Models MF240 and MF250 equipped with Lucas alternator.



rectifier (14), then remove rectifier from housing. Remove retaining bolts and withdraw housing and stator from end frame.

Remove pulley and fan from rotor shaft, then press rotor assembly (7) out of front bearing and end frame. Remove snap ring and retainer plate (6), bearing (5) and felt seal and retainer assembly (4) from end frame. To remove rear bear-

ing (8), slip ring (9) connections must first be unsoldered and rings pried from shaft. Use a suitable puller to remove bearing.

Inspect brushes and rotor slip rings for wear and renew if necessary. Brush length when new is 20 mm (0.787 inch). Renew brushes if length is less than 10 mm (0.394 inch). Brush spring tension should be 1.3-2.7 N (4.7-9.8 ounces). Con-

nect ohmmeter leads between the two rotor slip rings to check field winding resistance. Ohmmeter should register 3.2 ohms. Check for continuity between slip rings and rotor frame. If continuity is indicated, field winding is grounded and rotor should be renewed.

Test stator windings for grounded or open circuits as follows: Connect ohmmeter leads between stator frame and each lead wire. A low reading would indicate a grounded circuit. Connect tester leads successively between each pair of stator leads. A high reading would indicate an open circuit.

Reassemble alternator by reversing the disassembly procedure. Be sure to align match marks on housings made prior to disassembly.

**Models MF240-MF250 With Perkins Alternator**

**105. TESTING.** To check alternator output, connect a voltmeter between "D+" terminal of alternator and ground. Start the engine and observe voltmeter reading. Voltage should be within range of 13 to 15 volts. If voltmeter reading exceeds 15.5 volts, voltage regulator is faulty. If voltmeter reading is less than 13 volts, insert a pin into small hole near the center of alternator rear housing to ground the "F" terminal. If voltage is now within range of 13 to 15 volts, regulator is faulty. If voltage remains less than 13 volts, disassemble alternator and check field winding, diodes and stator as outlined in paragraph 106.

**106. OVERHAUL.** Prior to disassembly, scribe matching marks across end frame (4--Fig. 108) and rear housing (14) to ensure correct alignment for reassembly. Remove four through-bolts, then separate end frame with rotor from rear housing and stator. Hold rotor in a vise, then remove pulley nut, pulley (1), fan (2) and spacer (3) from rotor shaft. Separate rotor from end frame. Remove front bearing (5) from end frame and rear bearing (8) from rotor if necessary.

Remove five nuts attaching brush holder/diode/stator assembly to rear housing. Unsolder stator wires from diodes. Drill out rivet between brush box (12) and diode rectifier (11). Unsolder brush box and regulator from rectifier. Unsolder the regulator to brush box terminals and separate regulator from brush box.

Renew brush holder assembly if brush "free" length from end of holder is less than 2 mm (0.080 inch). This minimum allowable length is marked on the brushes by a groove on one side of each brush.

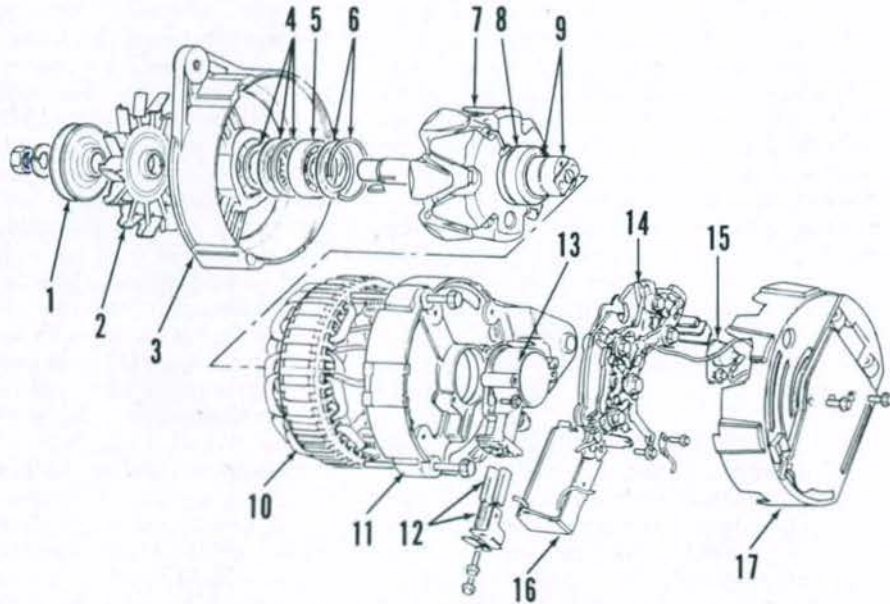

Fig. 107—Exploded view of typical Lucas alternator used on some MF240 and MF250 tractors.

- |                               |                               |                       |                            |
|-------------------------------|-------------------------------|-----------------------|----------------------------|
| 1. Pulley                     | 5. Bearing                    | 9. Slip rings         | 14. Rectifier assy.        |
| 2. Fan                        | 6. Retainer plate & snap ring | 10. Stator            | 15. Surge protection diode |
| 3. Drive end frame            | 7. Rotor                      | 11. Slip ring housing | 16. Regulator              |
| 4. Felt seal & retainer assy. | 8. Bearing                    | 12. Brushes & springs | 17. End cover              |
|                               |                               | 13. Brush holder      |                            |

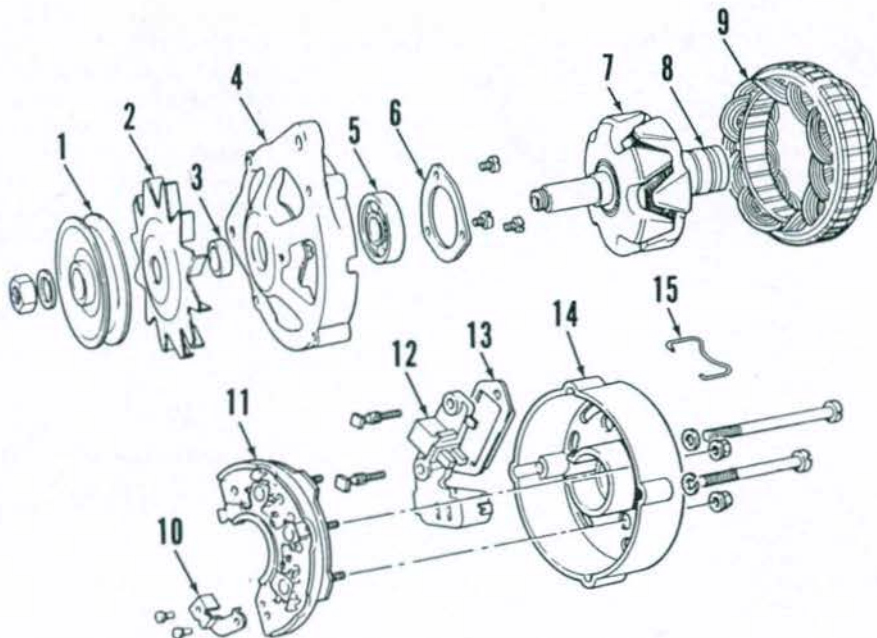

Fig. 108—Exploded view of Perkins alternator used on some MF240 and MF250 tractors.

- |              |                   |                        |                   |
|--------------|-------------------|------------------------|-------------------|
| 1. Pulley    | 5. Bearing        | 9. Stator              | 13. Regulator     |
| 2. Fan       | 6. Retainer plate | 10. Diode terminal     | 14. Rear housing  |
| 3. Spacer    | 7. Rotor          | 11. Diode rectifier    | 15. Terminal clip |
| 4. End frame | 8. Bearing        | 12. Brush holder assy. |                   |

Current flows in one direction only in each of the six diodes. Check each diode for directional continuity using a battery

powered 12 volt test lamp or an ohmmeter. Connect tester leads to positive and negative side of diode, then reverse

tester lead connections. Test lamp should light or ohmmeter should indicate continuity in one direction only. If continuity is indicated in both directions or if there is no continuity in either direction, diode is defective and rectifier assembly must be renewed.

Check rotor field winding for open circuit by connecting test lamp or ohmmeter leads to each of the rotor slip rings. If no continuity is indicated, rotor is faulty and must be renewed. Check for continuity between the slip rings and rotor shaft. If continuity is indicated, winding is grounded and rotor must be renewed.

Check for continuity between each of the stator coil leads. Renew stator if an open circuit is indicated. Check for continuity between each of the stator coil leads and the stator frame. If continuity is indicated, winding is grounded and stator must be renewed.

To reassemble alternator, reverse the disassembly procedure while noting the following special instructions: Tighten

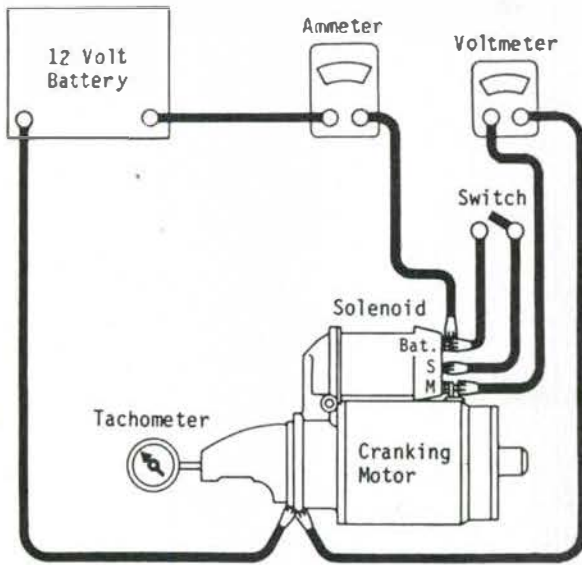
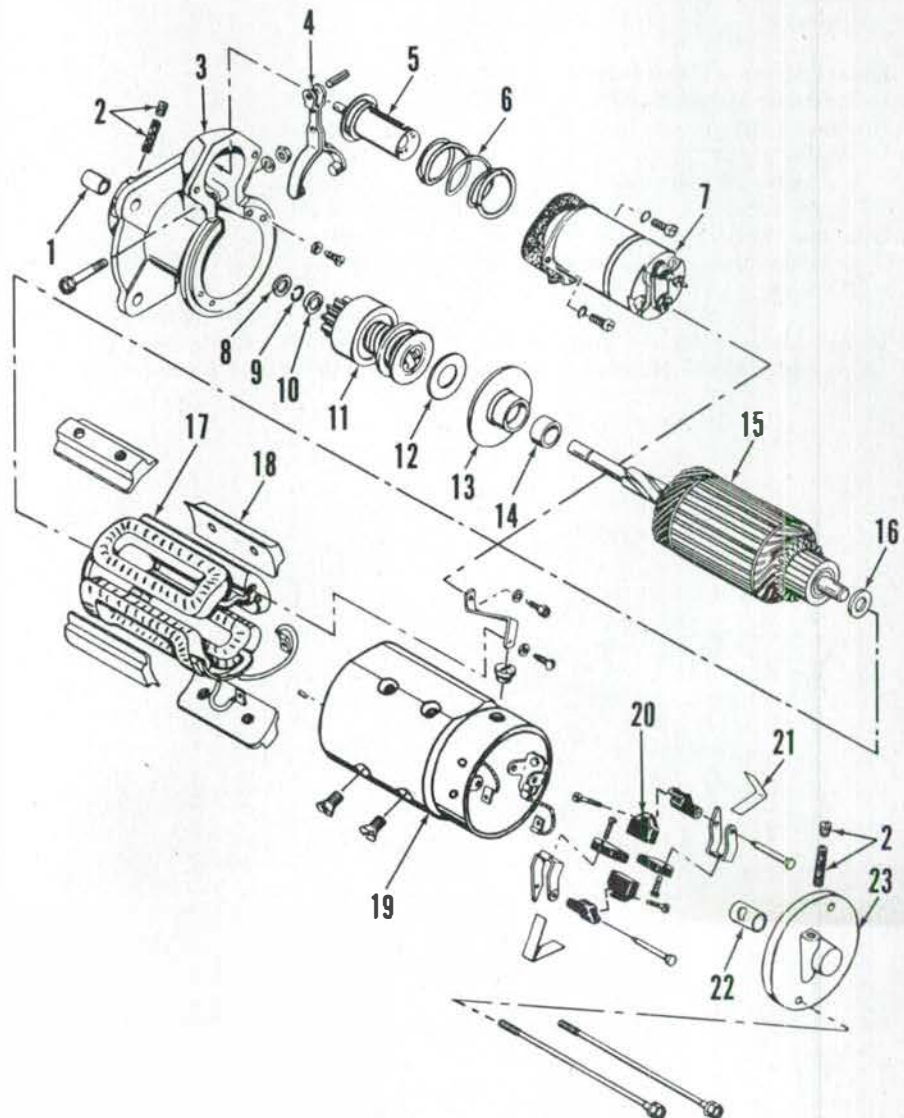

Fig. 109—Connect ammeter, voltmeter and a switch as shown to perform no-load test on starting motor. Refer to text for specifications.

Fig. 110—Exploded view of typical Delco-Remy starting motor used on MF230, MF235 and MF245 tractors.

1. Bushing
2. Oil wick & plug
3. Drive housing
4. Shift lever
5. Plunger
6. Spring
7. Solenoid
8. Thrust washer
9. Snap ring
10. Retainer
11. Drive pinion
12. Fiber washer
13. Center bearing housing
14. Bushing
15. Armature
16. Thrust washer
17. Field coil
18. Pole shoes
19. Field frame
20. Brushes
21. Springs
22. Bushing
23. Frame



brush holder/diode assembly retaining nuts to 3.1-3.9 N·m (28-24 ft.-lbs.) torque. Tighten pulley retaining nut to 44.59 N·m (33-43 ft.-lbs.) torque. Push brushes up into holder and insert a pin through hole in center of rear cover to hold brushes in this position. Remove brush retaining pin after rotor is installed. Tighten the through-bolts to a torque of 3.1-3.9 N·m (28-34 in.-lbs.).

**STARTING MOTOR**

**Models MF230-MF235-MF245**

107. A Delco-Remy starting motor is used on all models. Connect voltmeter and ammeter to starting motor as shown in Fig. 109 to perform no-load test.

**Gasoline Models**

**Delco-Remy Model**

Number . . . . .1108323 and 1108324

**No-Load Test:**

Volts . . . . .9  
Amperes (w/solenoid) . . . . .50-80  
Rpm . . . . .5500-10500

**Diesel Models (Standard)**

Delco-Remy Model Number . . 1107870

**No-Load Test:**

Volts . . . . .9  
Amperes (w solenoid) . . . . .50-80  
Rpm . . . . .5500-9000

**Solenoid Model Number:**

Production . . .1113391 and 1114466  
Service . . . .1114356 and 1114458

**Diesel Models (Heavy Duty)**

Delco-Remy Model Number . . 1109257

**Fig. 112—Exploded view of typical Perkins starting motor used on some MF240 and MF250 tractors.**

1. Solenoid
2. Spacer washers
3. Plunger
4. Pivot pin
5. Shift lever
6. Dust seal
7. Brush
8. Field winding
9. Housing
10. Drive housing
11. Bushing
12. End cover
13. Brush holder assy.
14. Brush & spring
15. Thrust washers
16. Armature
17. Center bearing plate
18. Drive pinion
19. Pinion stop
20. Snap ring

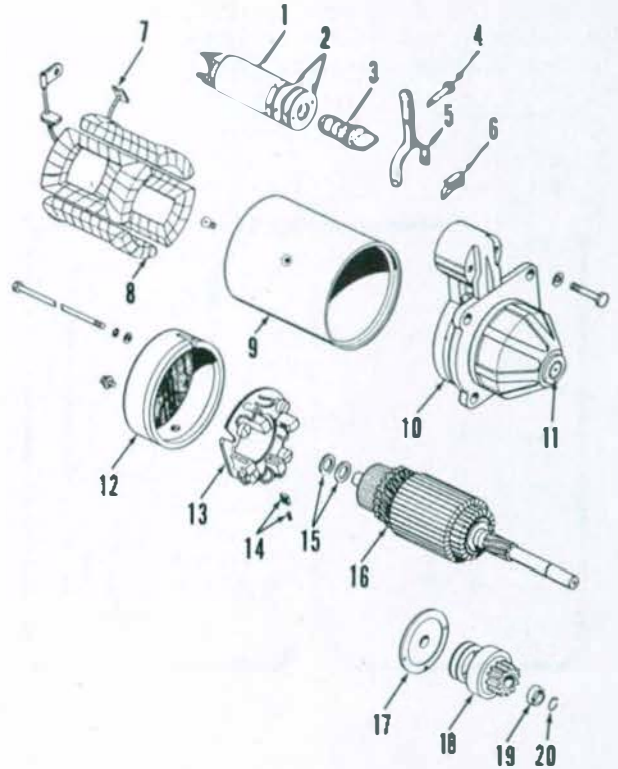

**No-Load Test:**

Volts . . . . .9  
Amperes (w/solenoid) . . . . .20-120  
Rpm . . . . .9000-14000

**Solenoid Model Number:**

Production . . . . .1114381  
Service . . . .1114381 and 1114458

Refer to Fig. 110 for exploded view of typical Delco-Remy starting motor. Starter drive pinion clearance is not ad-

justable; however, some clearance must be maintained between end of pinion and starter drive frame to assure solid contact of the magnetic switch. Normal pinion clearance should be within the limits of 0.25-3.56 mm (0.010-0.140 inch). Connect a 6 volt battery to solenoid terminals when measuring pinion clearance to keep armature from turning.

**Models MF240-MF250**

108. LUCAS STARTING MOTOR. A Lucas starting motor is used on some MF240 and MF250 tractors. Connect voltmeter and ammeter to starting motor as shown in Fig. 109 to perform no-load test. Specifications are as follows:

**No-Load Test--**

Volts . . . . .11  
Amperes (max.) . . . . .100  
Rpm . . . . .5000-7500

Refer to Fig. 111 for exploded view of typical Lucas starting motor. Brush spring tension should be between 11.6-15.5 N (42-55 ounces). Renew brushes if length is less than 8 mm (5/16 inch). When renewing armature bushings, new bushings should be soaked in engine oil for 24 hours prior to installation. Tighten the two through-bolts to a torque of 11 N·m (8 ft.-lbs.).

Starter drive pinion end clearance is adjustable. Connect a 6 volt battery to blade terminal on solenoid to hold pinion in engaged position. While pushing pin-

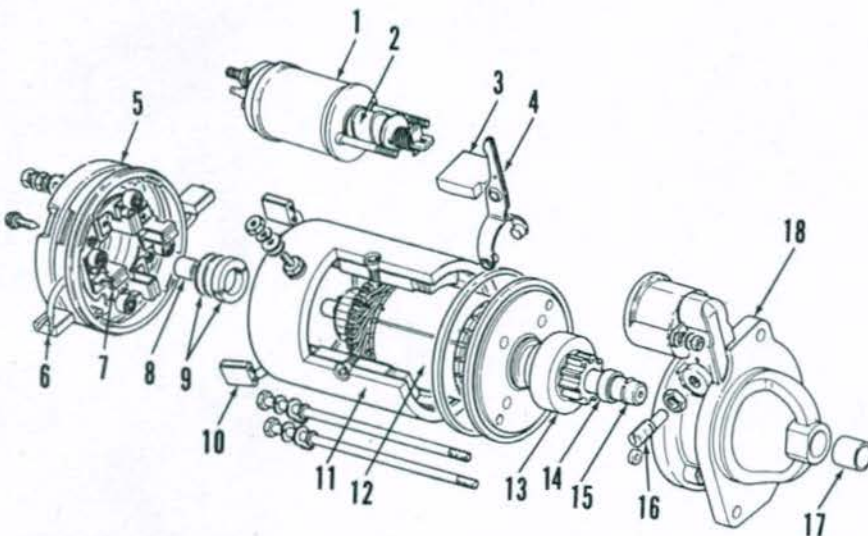

**Fig. 111—Exploded view of typical Lucas starting motor used on some MF240 and MF250 tractors.**

- |                  |                           |                       |                   |
|------------------|---------------------------|-----------------------|-------------------|
| 1. Solenoid      | 6. Brush                  | 10. Brush             | 14. Thrust collar |
| 2. Plunger assy. | 7. Brush holder & springs | 11. Field coil & body | 15. Snap ring     |
| 3. Dust seal     | 8. Bushing                | 12. Armature          | 16. Eccentric pin |
| 4. Shift lever   | 9. Armature brake assy.   | 13. Drive pinion      | 17. Bushing       |
| 5. End cover     |                           |                       | 18. Drive housing |

ion lightly towards armature to remove any free play in linkage, measure clearance between end of pinion (13) and the thrust collar (14). Turn eccentric pin (16) as required to obtain recommended clearance of 0.13-0.38 mm (0.005-0.015 inch). Tighten locknut to hold pin in position.

**109. PERKINS STARTING MOTOR.** A Perkins (Hitachi) starting motor is used on some MF240 and MF250 tractors. Connect voltmeter and ammeter to starting motor as shown in Fig. 109 to perform no-load test. Specifications are as follows:

No-Load Test—	
Volts .....	12
Amperes (max.) .....	120
Rpm .....	4000-7500

Refer to Fig. 112 for an exploded view of typical Perkins starting motor. Armature commutator minimum allowable diameter is 40 mm (1.575 inches). Maximum allowable runout for armature and commutator is 0.10 mm (0.004 inch). Depth of insulation below surface of commutator should be 0.20-0.80 mm (0.008-0.031 inch). Minimum allowable brush length is 14 mm (0.551 inch).

Armature end play should be 0.05-0.30 mm (0.002-0.012 inch). If end play exceeds 0.30 mm (0.012 inch), install an additional thrust washer (15).

Starter drive pinion end clearance is adjustable. Connect a 6 volt battery to solenoid "S" terminal to hold pinion in engaged position. Push pinion lightly towards armature to remove free play in linkage, then measure clearance between face of pinion gear and the pinion stop (19). Recommended clearance is 0.3-1.5 mm (0.012-0.060 inch). Add or remove spacer washers (2) as required to obtain desired clearance.

## ENGINE CLUTCH

Tractors may be equipped with a flywheel mounted dual stage clutch which permits continuous (live) pto or with a split torque clutch with independent pto. Refer to the appropriate following paragraphs for adjustment and overhaul procedure.

### ADJUSTMENT

#### Models MF230-MF240-MF250

110. Clutch pedal free travel (F—Fig. 113) is measured between top of clutch pedal shaft (4) and bottom of footrest spacer (3). Free travel should be 11 mm (7/16 inch). If incorrect, loosen clamp bolt (2), then insert a punch into hole of

release shaft (1) and rotate shaft until clutch release bearing contacts clutch levers (resistance is felt). Move pedal until desired free travel is obtained, then tighten clamp bolt.

#### Models MF235-MF245

111. Clutch pedal free travel is measured at (F—Fig. 114) between clutch shaft arm (2) and transmission housing. Free travel should be 4 mm (5/32 inch). If incorrect, loosen clamp bolt (1) and rotate clutch release shaft until throwout bearing just contacts clutch fingers. Move pedal until correct free travel is obtained, then tighten clamp bolt.

The length (R) of pedal linkage rod should be measured from center to center and adjusted to the following lengths as necessary.

#### Early Style (Pedal Pushes Downward)

Dual Stage Clutch—	
Orchard Models .....	295.3 mm (11-5/8 in.)

All Other Models .....	308 mm (12-1/8 in.)
Split Torque Clutch—	
All Models .....	298.5 mm (11-3/4 in.)
Late Style (Pedal Pushes Forward)	
Dual Stage Clutch—	
All Models .....	295.3 mm (11-5/8 in.)
Split Torque Clutch—	
All Models .....	285.8 mm (11-1/4 in.)

## TRACTOR SPLIT

### All Models

112. To detach engine from transmission assembly, disconnect battery cables and remove battery. Remove hood and instrument panel lower covers. Install wedge blocks between axle and axle support to prevent tipping. Remove front weights if so equipped. Disconnect wiring from starter, alternator, temperature gage sending unit, fuel gage sending

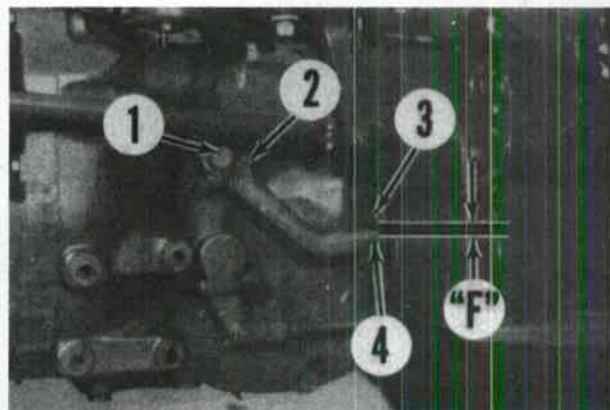

Fig. 113—Refer to text for clutch pedal free travel adjustment on MF230, MF240 and MF250 models.

1. Cross shaft
2. Clamp bolt
3. Footrest spacer
4. Clutch pedal

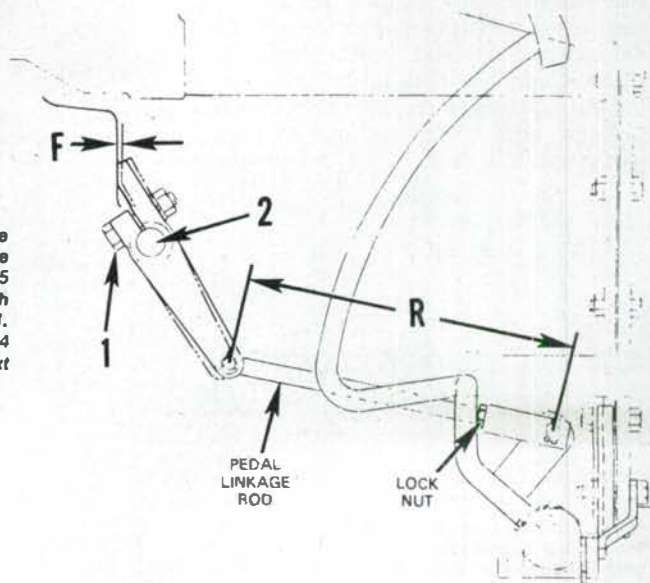

Fig. 114—Drawing of late style clutch pedal linkage used on MF235 and MF245 models. Early style clutch pedal pushes downward. Clearance "F" should be 4 mm (5/32 inch). Refer to text for rod length (R).

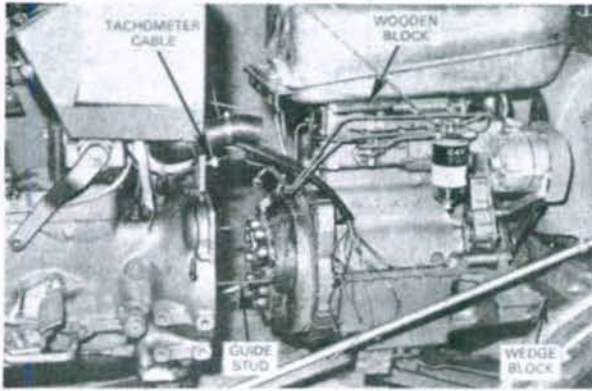

Fig. 115—View of tractor split showing location of wooden block to hold fuel tank, wedge block to prevent tipping and guide studs to aid in safe separation and joining.

unit and headlights, then pull all wires out of the way. Disconnect throttle rod, fuel shut-off cable, engine oil pressure gage line, tachometer cable, air cleaner hose and ground strap. On models so equipped, disconnect hydraulic oil lines, power steering lines, drag links, radius rods and/or horizontal muffler. On all models, remove screws attaching the rear fuel tank mounting bracket and block tank up as shown in Fig. 115 using a wooden block. On models with steering drag links, secure drag links so wheels are straight and will not turn. Support engine and transmission independently so engine and front system can be moved forward away from transmission. Remove screws securing engine to transmission housing, remove starting motor and install guide studs. Carefully move engine and front assembly forward as shown in Fig. 115.

When rejoining tractor, be sure to use a guide stud in each side of transmission housing to assist in alignment. Turn flywheel to align clutch plate splines with transmission and pto input shaft splines. When engine and transmission flanges meet, install retaining cap screws and remove guide studs. Do not use cap screws to force units together as damage to clutch and transmission may result. Complete installation by reversing the splitting procedure. Check clutch linkage adjustment as outlined in paragraph 110 or 111.

DUAL CLUTCH

All Models So Equipped

113. REMOVE AND REINSTALL. Refer to paragraph 112 and separate engine from transmission. Punch mark the clutch cover (16—Fig. 118), pressure plate (14), drive plate (12), pressure plate (7) and engine flywheel so parts can be reinstalled in their original positions. Install the three special bolts shown in Fig.

116 and tighten nuts to compress clutch springs. Three ¼ inch UNC cap screws that are 2-1/8 inches (54 mm) long can also be used instead of special “T” bolts to compress clutch springs. Remove retaining cap screws and lift clutch assembly from flywheel as shown in Fig. 117.

To reinstall clutch, first position transmission friction disc (6—Fig. 118) in flywheel with hub side facing away from flywheel. Position air ring (5) on flywheel if so equipped. Use a suitable pilot shaft to align clutch discs and install clutch assembly while aligning previously made assembly punch marks. Tighten retaining cap screws to 41 N · m (30 ft.-lbs.) torque. Remove “T” bolts and pilot shaft. Adjust clutch, if necessary, as outlined in paragraph 115.

114. OVERHAUL. Before disassembling clutch, punch mark the clutch cover, pto pressure plate, drive plate and transmission pressure plate so parts can be reassembled in the same relative positions. Unhook release lever torsion springs (22—Fig. 118). Back off “T” bolt nuts until pivot pin retainer pins (21), early style clutch, can be driven free of pivot pins (20). Do not attempt to drive retaining pins completely out of cover. On late style clutches, remove retaining clips from release lever pivot pins. On all models, remove pivot pins and lever springs. Disconnect release levers (17) from links (4). Loosen “T” bolt nuts evenly to release spring pressure, then remove “T” bolts and separate clutch components.

Thoroughly clean and examine all parts for wear or damage. Renew any parts which are questionable. Flywheel friction surface may be resurfaced up to a maximum depth of 1.0 mm (0.040 inch). An equal amount of material must also be removed from clutch mounting surface of flywheel to maintain correct clutch spring tension. It is not permissible to resurface pressure plates (7 and 14) or drive plate (12). Insulating washers (9) should be renewed when new springs (10) are installed.

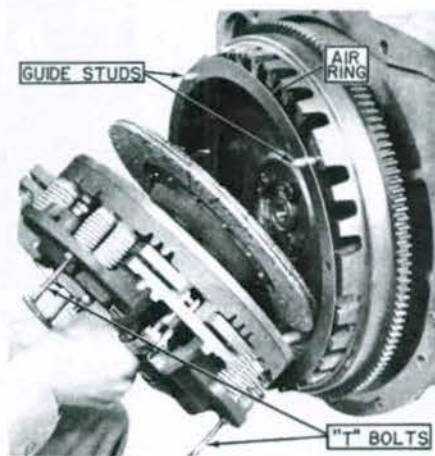

Fig. 117—View showing removal/installation of typical dual clutch assembly. Air ring is not used on later models.

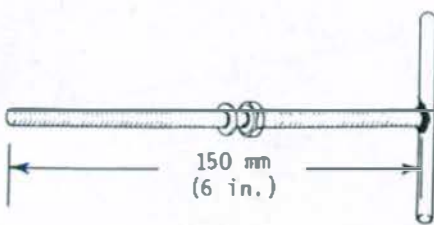
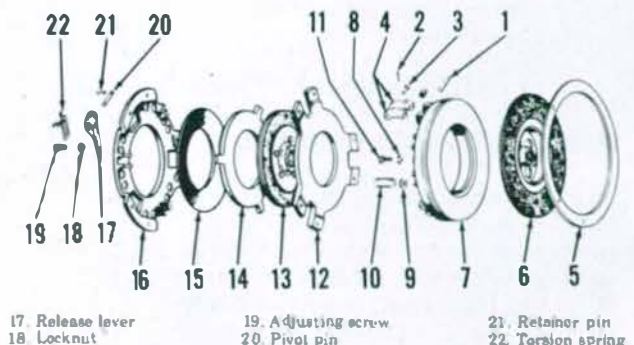

Fig. 116—Special “T” bolts can be made to facilitate clutch removal, repair and installation. Weld a cross handle to six-inch piece of 1/4 inch UNC threaded rod. A forcing nut and washer is used to compress the clutch springs.

Fig. 118—Exploded view of typical dual clutch assembly. Air ring (5) is not used on later models.

- 1 Pin
- 2 Cotter pin
- 3 Link pin
- 4 Link
- 5 Air ring
- 6 Transmission disc
- 7 Pressure plate
- 8 Locknut
- 9 Insulating washer
- 10 Clutch spring
- 11 Adjusting screw
- 12 Drive plate
- 13 Pto disc
- 14 Pressure plate
- 15 Belleville spring
- 16 Clutch cover



- 17 Release lever
- 18 Locknut

- 19 Adjusting screw
- 20 Pivot pin

- 21 Retainer pin
- 22 Torsion spring

To reassemble, place clutch cover upside down on bench, then center Belleville spring in cover with convex side up. Place pressure plate on spring aligning assembly punch marks. Install pto clutch disc with hub side down. Install pto drive plate aligning assembly marks, then temporarily hold drive plate and clutch cover together using three 5/16 x 1-1/2 inch bolts through flywheel mounting holes.

Reinstall links, levers and retaining pins on main pressure plate making certain head of pin is positioned as shown in Fig. 119. Position cover assembly onto coil springs guiding release levers through holes in cover. Make sure the assembly punch marks are all aligned. Install release lever springs. Install the "T" bolts and tighten forcing nuts evenly to compress clutch springs until release lever pivot pins can be installed. Hook torsion springs into recesses in clutch cover. Remove the three bolts securing clutch cover to pto drive plate.

Reinstall clutch and check adjustment as outlined in paragraph 115.

**115. ADJUSTMENT.** After clutch assembly has been installed on flywheel, two adjustments are necessary for proper clutch operation. Proceed as follows:

**NOTE:** Clutch assembly must be installed with a new primary friction disc (6—Fig. 118), even if a partially worn disc is to be reinstalled, to obtain accurate adjustment of clutch.

Check the clearance between head of pto clutch adjusting screws and surface of pto pressure plate. Adjust the screws as required to provide 1.98-2.08 mm (0.078-0.082 inch) clearance.

Adjust release lever adjusting screws (19) as required so distance from top of each screw to inner lip of flywheel is 82.55-83.31 mm (3.250-3.280 inches). Be sure all screws are adjusted evenly.

Fig. 120—Exploded view of split torque clutch assembly used on some MF235 and MF245 tractors.

1. Pin
2. Adjusting screw
3. Release lever
4. Torsion spring
5. Clutch cover
6. Cup
7. Spring
8. Pressure plate
9. Clutch disc

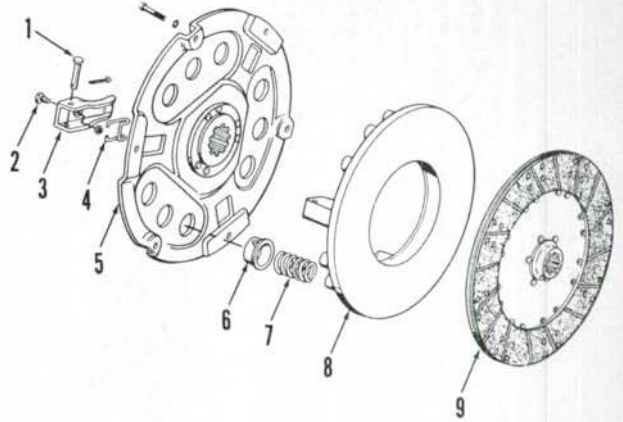

**SPLIT TORQUE CLUTCH**

**All Models So Equipped**

**116. REMOVE AND REINSTALL.** Refer to paragraph 112 and separate engine from transmission. Punch mark the clutch cover, pressure plate and flywheel so original balance can be maintained when reassembling. Loosen pressure plate retaining screws evenly to prevent warping the clutch cover.

Install clutch driven disc with side marked "FLYWHEEL SIDE" toward flywheel. The center hub will be riveted to front side of clutch disc center. Use a suitable aligning tool to align the driven disc splines and pto drive splines in cover. Align the previously affixed punch marks and tighten the retaining screws evenly to a final torque of 19-28 N·m (14-21 ft.-lbs.). Check and adjust release lever height as outlined in paragraph 117.

**117. ADJUSTMENT:** To adjust clutch lever height, turn adjusting screws (2—Fig. 120) as required so distance from top of each screw to inner lip of flywheel is 82.55-83.31 mm (3.250-3.280 inches). Be sure screws are adjusted evenly.

**118. OVERHAUL.** To disassemble the removed pressure plate cover unit, place the assembly in a press as shown in Fig. 121 and apply only enough pressure to relieve tension on pins. Remove pins (1—Fig. 120) and lift off cover. Inspect release levers and pins for wear or damage and pressure plate for scoring, heat checks or wear at actuating pin bores. Pressure plate must not be resurfaced. It is permissible to resurface flywheel friction surface to a maximum depth of 1.0 mm (0.040 inch). An equal amount of material must also be removed from clutch mounting surface of flywheel to maintain correct clutch spring tension. Inspect splines in pto drive hub for wear or damage. Renew clutch springs if there are indications of heat discoloration or distortion.

Reassemble by reversing the disassembly procedure making sure that assembly punch marks are aligned. Install release lever pivot pins with heads leading in direction of clutch rotation as shown in Fig. 121.

Reinstall clutch, then adjust release lever height, if necessary, as outlined in paragraph 117.

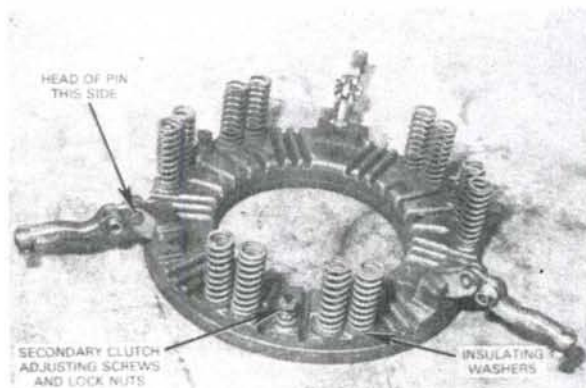

Fig. 119—Be sure clutch release levers are installed with head of retaining pin positioned as shown.

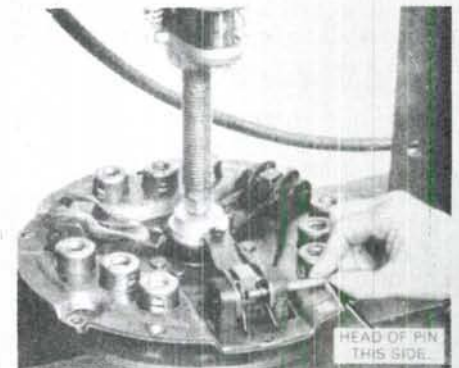

Fig. 121—Use a press to disassemble and reassemble split torque clutch. Be sure unit is assembled with head of pivot pin on leading side as shown.



# SIX-SPEED TRANSMISSION

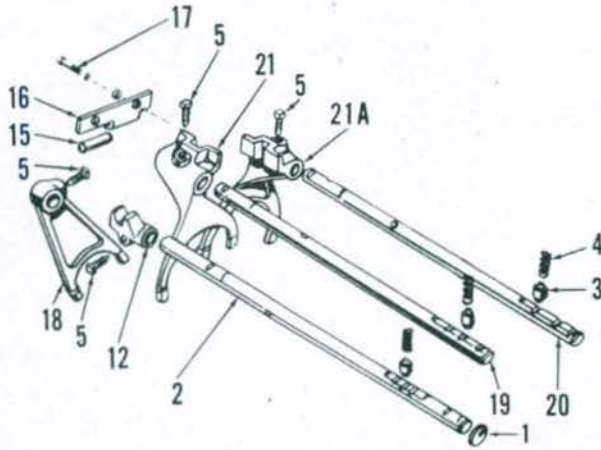

Fig. 122—Exploded view of shifter rails and forks of the type used on six-speed models.

1. Expansion plug
2. Planetary rail
3. Detent plunger
4. Spring
5. Fork set screw
12. Selector
15. Selector lock pin
16. Stop plate
17. Cap screw
18. Planetary shift fork
19. Low & reverse rail
20. Second & high rail
- 21 & 21A. Shift forks

Models MF230, MF235 and MF245 may be equipped with three-speed sliding gear set compounded by a dual range planetary reduction gear set which provides six forward speeds and two reverse speeds.

## TRANSMISSION REMOVAL

### All Models So Equipped

119. To remove the complete six-speed transmission unit from the tractor, first drain transmission and hydraulic system fluid and separate engine with fuel tank from transmission as outlined in paragraph 112.

Remove battery support with air cleaner from tractor. Remove cap screws attaching shift cover to top of transmission. Attach a suitable hoist to steering support, then lift steering column, instrument panel and shift cover from transmission.

Remove both step plates, disconnect clutch pedal rod and both brake rods, then unbolt clutch pedal bracket. Attach hoist to transmission and support differential housing, then unbolt transmission from differential housing. Install guide studs and carefully slide transmission forward away from differential housing.

Rejoin transmission to differential housing completely before installing the attaching screws. It may be necessary to reach through response control opening to turn pto coupling before transmission will slide up to differential housing. Tighten the screws attaching differential housing to transmission housing to 68-75 N·m (50-55 ft.-lbs.) torque.

When reinstalling shift cover, place all gears in neutral and be sure detent pins and springs are correctly positioned under gasket. Lower cover into position over guide studs making sure levers

engage shift rails. Tighten cover screws to 47 N·m (35 ft.-lbs.) torque.

Reconnect transmission to engine as outlined in paragraph 112.

## SHIFTER RAILS AND FORKS

### All Models So Equipped

120. To remove shifter rails and forks, first remove transmission top cover and detach transmission housing from dif-

ferential housing as outlined in paragraph 119. Remove detent springs (4—Fig. 122) and plungers (3) from top of housing. Remove shift rail interlock plate (16) from rear of housing. Remove set screws retaining shift forks to rails, then withdraw shift rails and forks from transmission case.

When reinstalling, be sure planetary selector (12) is positioned with fork upward and set screw hole towards outside of case. Shift forks (21 and 21A) are interchangeable, but shift rails (19 and 20) are not. Be sure shift rails are positioned so milled flat area of each shaft is at the rear and facing upward and the notch in rear end of each shaft for interlock pin is facing inward. Tighten set screws securely and lockwire in place.

## PLANETARY UNIT

### All Models So Equipped

121. The planetary unit can be removed after separating transmission case from differential housing. Remove planetary shift fork (18—Fig. 123) and coupler (42). Remove cap screws retaining planetary rear cover (41) and ring gear (32) to transmission case. Withdraw planetary carrier assembly from ring gear, then use two screwdrivers to pry ring gear and dowels from case.

Planet pinion shafts (39—Fig. 124) are a tight press fit in planet carrier (40); use a suitable press when removing and installing. Two rows of (27 each) loose needle rollers (38) are used in each planet pinion, separated and spaced by three washers (36). Use viscous grease to stick thrust washers (35) to gears, and completely assemble the bearing, before attempting to install the pinion shafts (39).

Be sure shim (30) and front plate (31) are positioned with cutaway slot towards top of planetary. Oil groove side of front and rear plates (31 and 41) should face inward. Use light coating of grease to hold thrust washers (33) in position. Cutaway section of rear plate (41) should be on bottom right-hand corner as shown in Fig. 123. Cap screw (S) should be installed without lockwasher. Tighten retaining cap screws to 41-47 N·m (30-35 ft.-lbs.) torque.

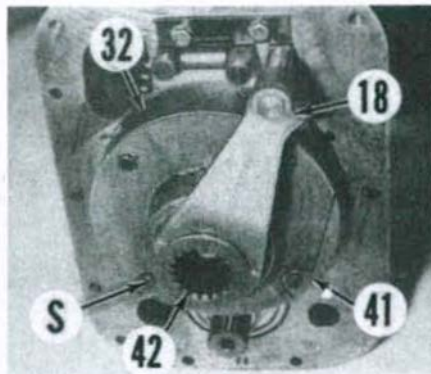
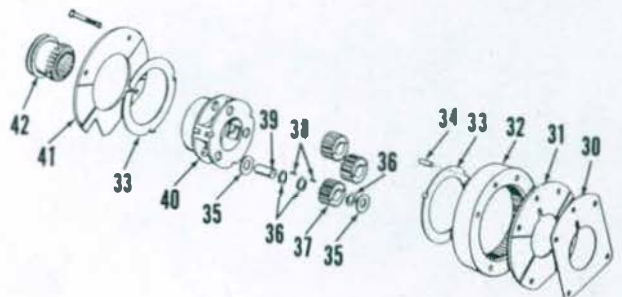

Fig. 123—View of planetary assembly installed on rear of transmission case. Cutaway section of rear plate (41) should be on lower right-hand side as shown. Cap screw (S) should be installed without lockwasher. Refer to Fig. 124 for legend.

Fig. 124—Exploded view of planetary assembly.

30. Shim
31. Front plate
32. Ring gear
33. Thrust washer
34. Dowel
35. Thrust washer
36. Spacer washer
37. Planet gear
38. Needle rollers
39. Shaft
40. Planet carrier
41. Rear cover
42. Shift coupler



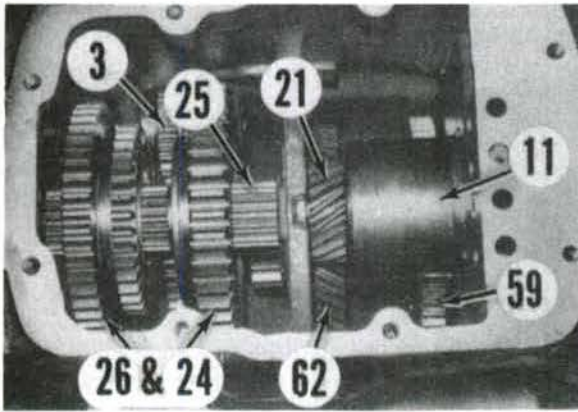

Fig. 125—Top view of six-speed transmission assembly with shift rails removed. Refer to Fig. 126 for legend.

**INPUT SHAFTS**

**All Models So Equipped**

122. To remove input shafts (15 and 21—Fig. 126), it is first necessary to remove transmission from tractor as outlined in paragraph 119. Remove brake cross shaft and clutch release bearing and fork. It is also necessary to move pto lower shaft (60) rearward to allow pto gear (59) to drop down into case to provide clearance for removal of input shafts and retainers as an assembly; proceed as follows: Remove cover plate (50) at front of pto shaft. Remove snap ring (53) from shaft, then thread two cap screws into tapped holes in bearing housing (56) to force bearing and bearing from shaft. Pull pto shaft rearward until pto gear drops to bottom of case. Remove cap screws attaching input shaft retainer (11) to case, then withdraw input shafts and retainer as an assembly.

To disassemble, remove snap ring (20) and bump transmission input shaft (21) and bearing (19) rearward from retainer.

Note that Loctite adhesive is used on outer diameter of bearing to aid in retaining it in housing. Heating housing at bearing area will make removal easier. Remove snap ring (17), then bump pto input shaft (15) with bearings from housing.

When reassembling, be sure to renew oil seals (13 and 16). Lips of seals must face rearward. Apply a suitable sealant

to outer diameter of seals. Lubricate seal lips with grease prior to installation of input shafts. When renewing bearings, note that "open" side of bearings must face away from gear teeth. Use a suitable seal protector sleeve over splined end of pto input shaft and transmission input shaft to avoid damaging oil seals as input shafts are installed. Apply Loctite 271 adhesive to outer diameter of transmission shaft bearing (19).

Reinstall bearing retainer with shafts making certain cutout section of housing for pto drive gear is towards bottom of case. Apply a suitable nonhardening sealer to threads of mounting cap screws, then tighten to 54-61 N·m (40-45 ft. lbs.) torque. Reinstall pto lower shaft as outlined in paragraph 125.

**MAINSHAFT AND SLIDING GEARS**

**All Models So Equipped**

123. To remove mainshaft (25—Fig. 126) and sliding gears, first remove transmission assembly as outlined in paragraph 119. Remove shift forks and rails as outlined in paragraph 120,

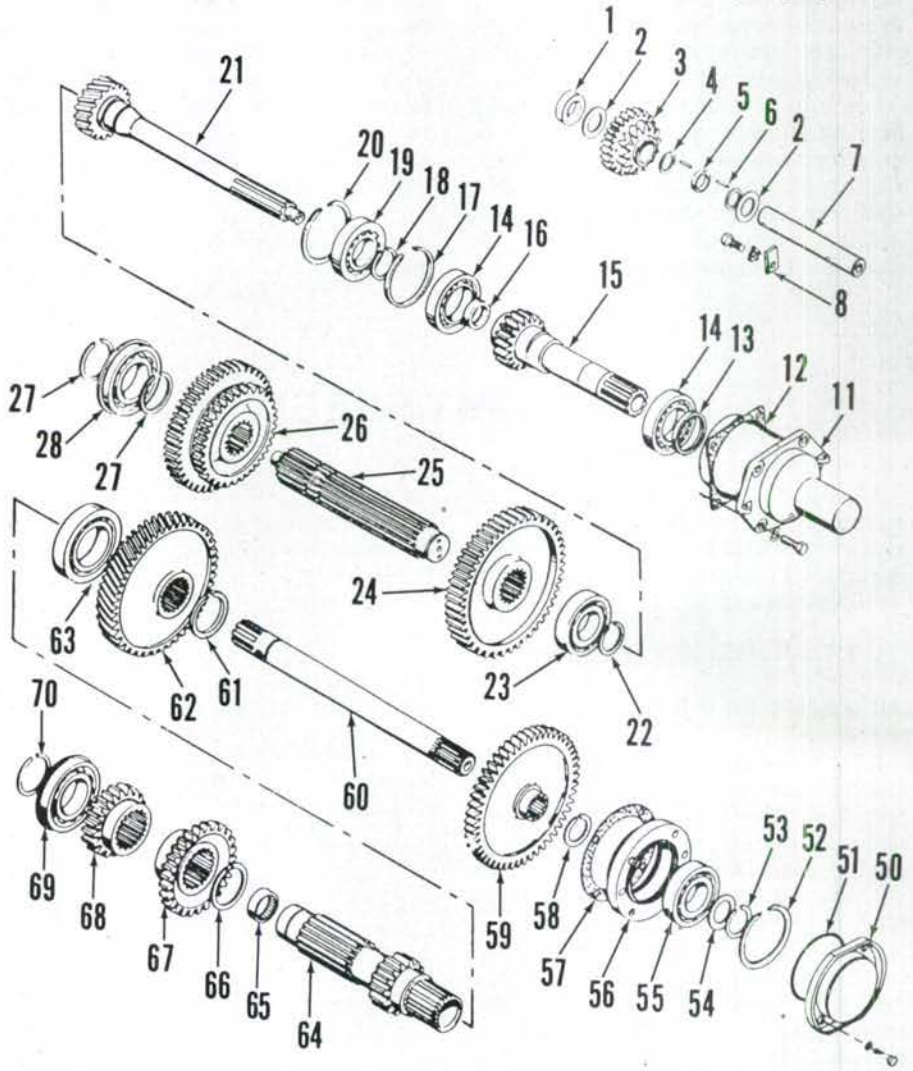

Fig. 126—Exploded view of six-speed transmission, gears, shafts and related components. Planetary unit is shown in Fig. 124.

- |                                  |                             |
|----------------------------------|-----------------------------|
| 1. Spacer                        | 26. 2nd & 3rd gear          |
| 2. Thrust washer                 | 27. Snap ring               |
| 3. Reverse idler gear            | 28. Bearing                 |
| 4. Washer                        | 29. Cover                   |
| 5. Spacer                        | 30. "O" ring                |
| 6. Needle rollers                | 31. Snap ring               |
| 7. Idler shaft                   | 32. Snap ring               |
| 8. Retainer clip                 | 33. Washer                  |
| 11. Input shaft retainer housing | 34. Bearing                 |
| 12. Gasket                       | 35. Retainer housing        |
| 13. Seal                         | 36. Gasket                  |
| 14. Bearing                      | 37. Snap ring               |
| 15. Pto input shaft              | 38. Pto drive gear          |
| 16. Oil seal                     | 39. Pto lower shaft         |
| 17. Snap ring                    | 40. Snap ring               |
| 18. Snap ring                    | 41. Countershaft drive gear |
| 19. Bearing                      | 42. Bearing                 |
| 20. Snap ring                    | 43. Countershaft            |
| 21. Transmission input shaft     | 44. Bearing                 |
| 22. Snap ring                    | 45. Snap ring               |
| 23. Bearing                      | 46. 3rd gear                |
| 24. 1st gear                     | 47. 2nd gear                |
| 25. Mainshaft                    | 48. Bearing                 |
|                                  | 49. Snap ring               |
|                                  | 50. Snap ring               |

remove planetary unit as outlined in paragraph 121 and remove input shafts as outlined in paragraph 122.

Remove snap ring (22) from front of mainshaft, then bump shaft rearward out of front bearing. Withdraw shaft rearward while lifting gears (24 and 26) out top opening of case.

Note that mainshaft diameter at the rear is slightly larger than at front. Rear bearing (28) must be removed and reinstalled over forward end of shaft.

To reinstall mainshaft and gears, reverse the removal procedure. Be sure "open" side of front bearing faces away from first/reverse gear (24).

**REVERSE IDLER ASSEMBLY**

**All Models So Equipped**

124. The reverse idler gear (3—Fig. 126) and shaft (7) can be removed after removing the mainshaft as outlined in paragraph 123.

Reverse idler shaft is retained by a clip (8) that fits into a notch in rear end of shaft. Push shaft rearward from housing and remove idler gear being careful not to lose the loose bearing rollers (6). A total of 56 bearing rollers are contained in bore of gear.

Use a light coating of grease to hold bearing rollers and washers in place in gear during reassembly. A dummy shaft, slightly smaller in diameter than idler shaft, can also be used to hold rollers and washers in correct position. Dummy shaft must be short enough that it can

be pushed out of front support boss and removed from housing as idler shaft is pushed into the gear from the rear. Be sure gear cluster is positioned in transmission with smaller gear teeth forward.

**PTO LOWER SHAFT AND GEARS**

**All Models So Equipped**

125. To remove pto lower shaft (60—Fig. 126) and gears, first remove transmission assembly as outlined in paragraph 119. Remove brake cross shaft, clutch release bearing and fork, and shift rails and forks. Remove front cover plate (50). Remove snap ring (53) from front of pto shaft, then thread two cap screws into tapped holes in bearing retainer (56) to force retainer and bearing off the shaft. Pull shaft rearward out of the countershaft. Unbolt and remove input shafts (15 and 21) and retainer (11) as a unit from housing. Lift pto gear (59) from transmission case.

When reassembling, be sure hub side of pto gear faces forward (away from countershaft). Install input shafts and retainer making certain cutout section of retainer faces downward. Apply nonhardening sealer to threads of retainer cap screws, then tighten to 54-61 N·m (40.45 ft.-lbs.) torque. Insert pto shaft through countershaft and pto gear. Install bearing retainer (56) with bearing over shaft. Use a suitable spacer tube, washer and bolt threaded into front end of shaft to pull pto shaft into the

front bearing until washer (54) and snap ring (53) can be installed at front of shaft. Install front cover, apply nonhardening sealer to threads of retaining cap screws and tighten to 54-61 N·m (40-45 ft.lbs.) torque.

**COUNTERSHAFT**

**All Models So Equipped**

126. To remove countershaft (64—Fig. 126) and gears, transmission must first be removed as outlined in paragraph 119. Remove shift rails and forks, planetary unit, pto lower shaft and gear, input shafts and retainer, and mainshaft as outlined in preceding paragraphs.

Remove snap ring (61) from front of countershaft and slide front gear (62) off the shaft. Remove snap ring (70) from rear of shaft, then use a block of wood and hammer to drive countershaft forward until free from rear bearing. Withdraw countershaft forward from housing and remove gears (67 and 68).

Renew parts as necessary. Be sure to install front bearing (63) with "open" side facing away from gear teeth on countershaft. Install needle bearing (65) flush with end of shaft. Install gears with hub sides facing together. Insert countershaft into housing from the front. Block front of shaft, then tap rear bearing onto shaft until snap ring (70) can be installed. Install constant mesh gear (62) and snap ring (61) onto front of countershaft.

**EIGHT-SPEED TRANSMISSION**

All models except MF230 may be equipped with a sliding gear transmission coupled with a dual range planetary reduction gear set providing eight forward speeds and two reverse.

**TRANSMISSION REMOVAL**

**All Models So Equipped**

127. To remove the complete eight-speed transmission unit from the tractor, first drain transmission and hydraulic system fluid and separate the engine from transmission housing as outlined in paragraph 112. Remove both step plates, disconnect clutch rod and both brake rods, then unbolt clutch pedal bracket. Disconnect the neutral starting switch and remove battery. Unbolt and remove the battery support and air cleaner. Attach hoist to transmission top

cover, then unbolt and lift cover from top of transmission case. Disconnect hydraulic line inside transmission com-

partment. Attach hoist to transmission and support differential housing, then unbolt transmission from differential

Fig. 127—Exploded view of eight-speed transmission shifter rails, forks and associated parts.

1. Shift interlock ball retainer
2. Bell
3. Gasket
4. Notched plate
5. Selector
6. Shift rail (2nd & 4th)
7. Detent spring & plunger
8. Fork
9. Shift rail (3rd)
10. Fork
11. Fork
12. Shift rail (1st & rev.)
13. Plug
14. Selector
15. Shift rail (planetary)
16. Fork

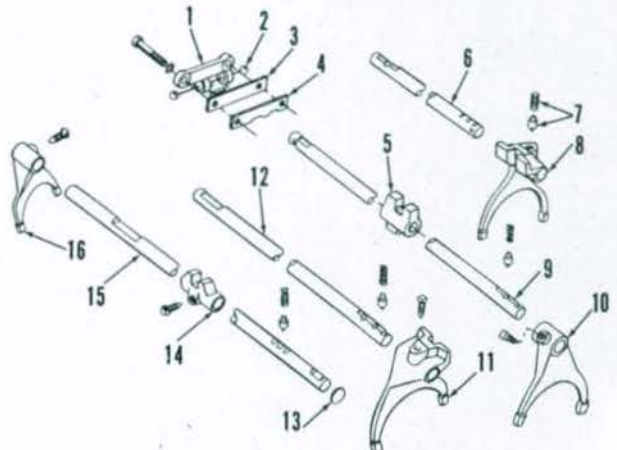

housing. Install guide studs and carefully slide transmission forward away from differential housing. Rejoin transmission to differential housing completely before tightening the retaining screws. It may be necessary to reach through opening for the response control cover and turn the pto coupling before transmission will slide up to differential housing. Tighten the screws attaching differential housing to transmission housing to 68-75 N·m (50-55 ft.-lbs.) torque. Be sure hydraulic line in transmission is reconnected. Transmission should be in neutral before installing shift cover. Make sure shift levers engage rails. Tighten screws retaining cover to 47 N·m (35 ft.-lbs.) torque.

## SHIFTER RAILS AND FORKS

### All Models So Equipped

128. To remove shifter rails and forks, transmission must be separated from differential housing and transmission top cover removed. Remove detent springs and plungers (7—Fig. 127) from top of transmission case. Remove set screws (except for center rail selector) from shift forks. Remove shift rail interlock mechanism (1) from rear of case. Remove planetary shift fork (16), rail (15) and selector (14). Withdraw right-hand and left-hand shift rails from case while removing shift forks and selector. Loosen set screw in center shift selector, then slide rail rearward and remove shift fork and selector. Identify shift rails and forks as they are removed to facilitate reassembly.

To reinstall shifter rails and forks, reverse the removal procedure while noting the following special instructions: Safety wire all set screws to prevent loosening. Be sure interlocking pin is installed in rear end of center shift rail. With shift forks in "Neutral", install lock mechanism with steel balls over center rail interlock pin. The widest part of notched stop plate (4) goes over planetary shift rail. Tighten interlock retainer cap screws to 41-47 N·m (30-35 ft.-lbs.) torque.

## PLANETARY UNIT

### All Models So Equipped

129. To remove the rear planetary unit, first detach transmission from differential housing using paragraph 127 as a general outline. Remove the planetary shift fork and coupling from rear of transmission case. Remove the four retaining screws and withdraw rear cover (41—Fig. 128), rear thrust washer (34) and planet carrier (40). Work planetary ring gear (32) and dowels (33) from case

using screwdrivers. Remove planetary front cover (31) and shim (30).

Planet pinion shafts (39) are a tight press fit in planet carrier (40). Use a suitable press for removing and installing pinion shafts.

Assemble and install unit as follows: Apply a light coat of petroleum jelly to one side of thrust washers (35), bearing needles (38) and spacer washers (36). Position one thrust washer (35) on bench with greased side up and locate pinion (39) over the washer. Install one spacer (36) in pinion, followed by one row of needles (38), a spacer (36), the second row of needles and the third spacer (36). Assemble the other two side pinions in the same way. Position the carrier (40) in a press with the hub side down, install the pinion, bearing and thrust washers assembly, then press pinion shaft into carrier until flush.

Position front plate (31) on ring gear (32) with oil grooves toward inside. Install shim (30) with slots on shim and front plate aligned and toward top when assembled to rear of case. Tap into position on rear case to be sure dowels are fully into case. Use a light coat of petroleum jelly to hold thrust washer (34) to the front of carrier (40) making sure tangs on washer engage notches of carrier. Insert carrier assembly into ring gear carefully so thrust washer doesn't fall. Make sure carrier is fully into ring gear and over mainshaft. Install the rear thrust washer making sure tangs engage notches of carriers. Install rear cover plate (41) with grooves inward. The notched section of cover should be over the bottom right-hand mounting bolt hole. Install bottom left-hand mounting cap screw without lockwasher. Install three remaining cap screws with lockwashers, then tighten all four cap screws to 47 N·m (35 ft.-lbs.) torque. Complete installation by reversing the removal procedure.

## PTO INPUT SHAFT

### All Models So Equipped

130. To remove pto input shaft (7—Fig. 129) and retainer (3), transmission must

first be separated from engine as outlined in paragraph 112. Remove clutch linkage, throwout bearing and brake cross shaft from front of transmission case. Disconnect hydraulic line (if used) from retainer (3). Remove retainer housing mounting cap screws, then withdraw housing with pto input shaft from transmission case.

To disassemble the removed unit, proceed as follows: Unseat and remove snap ring (4B), retaining bearing (5), then bump shaft and bearing rearward from housing. Bearing can be removed from shaft after removing snap ring (4A). Pry out oil seals (1 and 8) and remove needle bearing (2) if necessary.

When reassembling, be sure both oil seals are installed with lips facing rearward. Lubricate seals and needle bearing before assembling shaft into housing. Use of seal protector sleeves over splined ends of pto input shaft and main input shaft is recommended to avoid damaging oil seals during reassembly. Be sure to renew "O" ring (6). Apply nonhardening sealer to threads of housing mounting cap screws, then tighten to 60 N·m (45 ft.-lbs.) torque.

## TRANSMISSION INPUT SHAFT

### All Models So Equipped

131. To remove transmission input shaft (10—Fig. 129), first remove transmission assembly as outlined in paragraph 127. Remove pto input shaft and retainer housing as outlined in paragraph 130. Remove cover (50) from front of transmission case, and remove snap ring (52) from front of pto lower shaft (60). Thread two cap screws into tapped holes in bearing retainer (56) to force retainer and bearing (55) from front of pto lower shaft. Withdraw pto lower shaft rearward to permit pto drive gear (59) to drop to bottom of transmission case. Pull transmission input shaft forward to disengage it from mainshaft, then withdraw input shaft rearward from housing as shown in Fig. 130.

To reinstall transmission input shaft, reverse the removal procedure. Be sure rear thrust washer (11—Fig. 129) is posi-

Fig. 128—Exploded view of planetary assembly used on eight-speed transmissions.

- 30. Shim
- 31. Front cover
- 32. Ring gear
- 33. Dowel
- 34. Thrust washers
- 35. Thrust washers
- 36. Spacer washers
- 37. Planet gears
- 38. Needle rollers
- 39. Shaft
- 40. Planet carrier
- 41. Rear cover
- 42. Shift coupler

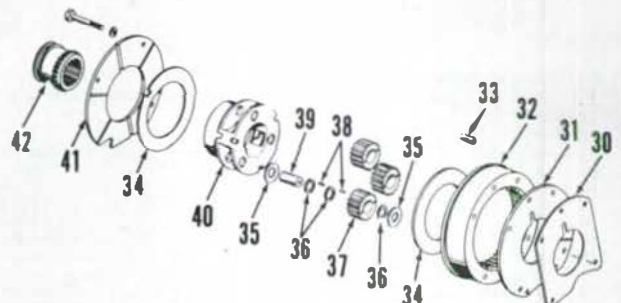

tioned on input shaft with grooved side facing rearward.

**MAINSHAFT AND SLIDING GEARS**

**All Models So Equipped**

132. To remove mainshaft (17—Fig. 129) and related components, first remove transmission as outlined in paragraph 127. Remove shifter rails and forks, planetary unit and main input shaft as outlined in previous paragraphs. Remove sliding gear (12) from front of mainshaft. Tap mainshaft rearward until front and rear bearings are free from transmission housing. Remove snap ring (13) from groove in front of bearing (14). Pull mainshaft rearward to remove front bearing from the shaft. Remove rear snap ring (13) from mainshaft, then slide shaft rearward from housing while lifting gears (18 and 19) out top opening.

Fig. 130—The transmission input shaft is removed and installed from the rear as shown on eight-speed transmission.

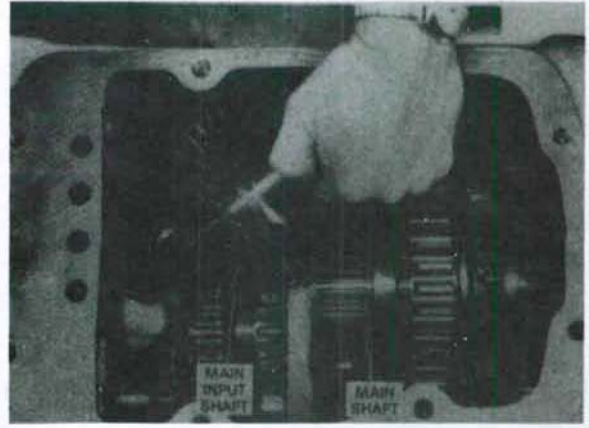

Remove bearings (16 and 21) from shaft if necessary. Note that rear bearing (21) must be removed and reinstalled over forward end of shaft.

To reinstall, reverse the removal procedure. Be sure cluster gear (19) is in-

stalled with smaller gear facing forward and gears (18 and 12) are positioned with shifter fork grooves facing forward.

**PTO LOWER SHAFT**

**All Models So Equipped**

133. To remove pto lower shaft (60—Fig. 129) and drive gear (59), the transmission must first be removed as outlined in paragraph 127. Remove shifter rails and forks as outlined in paragraph 128 and remove pto input shaft as outlined in paragraph 130. Remove cover plate (50), then remove snap ring (52) and washer (53) from front of shaft. Thread two cap screws into tapped holes in bearing retainer (56) to pull retainer and bearing (55) from front of shaft. Remove transmission input shaft as outlined in paragraph 131, then lift pto gear (59) from housing.

When reinstalling, be sure internal snap ring (58) is in place in bore of drive gear and that hub side of gear is towards the front. Insert pto shaft into housing from the rear. The front of pto shaft has a threaded hole that can be used to pull shaft into front bearing as shown in Fig.

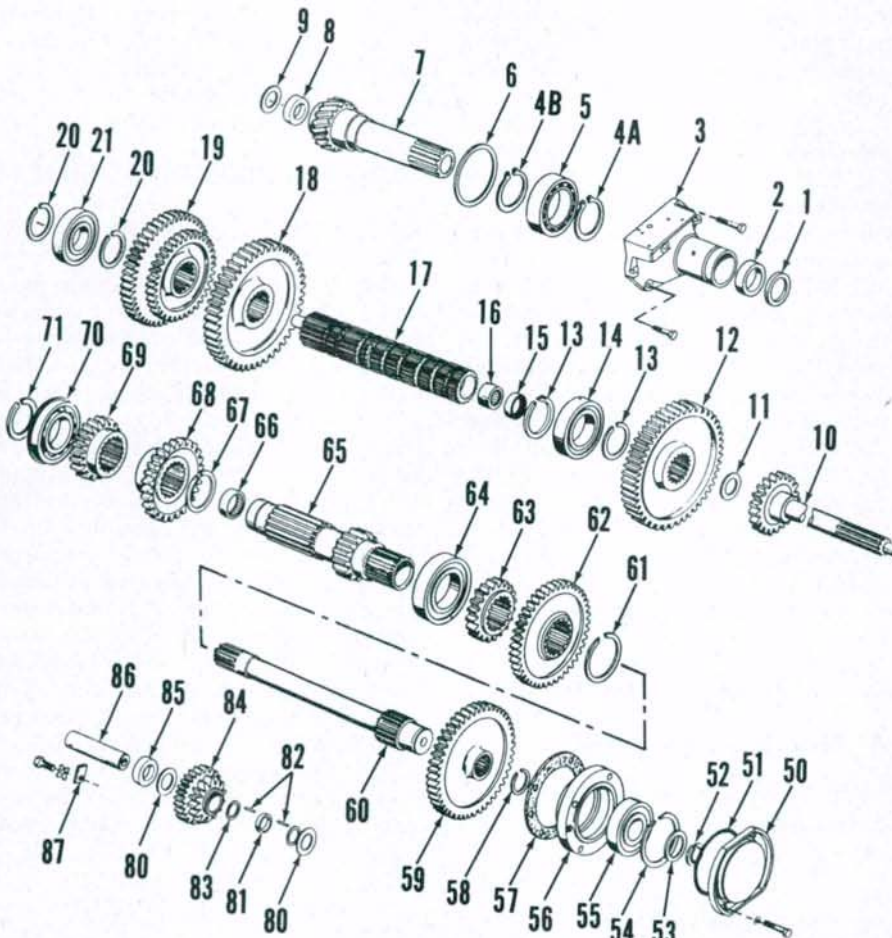

Fig. 129—Exploded view of eight-speed transmission input shafts, mainshaft, pto shaft, countershaft, gears and related components. Planetary unit is shown in Fig. 128.

- |                              |                   |               |                        |
|------------------------------|-------------------|---------------|------------------------|
| 1. Seal                      | 11. Thrust washer | 21. Bearing   | 59. Pto gear           |
| 2. Bearing                   | 12. Gear          | 50. Cover     | 60. Pto lower shaft    |
| 3. Retainer housing          | 13. Snap ring     | 51. "O" ring  | 80. Thrust washer      |
| 4A. Snap ring                | 14. Bearing       | 52. Snap ring | 81. Spacer             |
| 4B. Snap ring                | 15. Spacer        | 53. Washer    | 82. Needle rollers     |
| 5. Bearing                   | 16. Bearing       | 54. Snap ring | 83. Washer             |
| 6. Seal ring                 | 17. Mainshaft     | 55. Bearing   | 84. Reverse idler gear |
| 7. Pto input shaft           | 18. Gear          | 56. Retainer  | 85. Spacer             |
| 8. Seal                      | 19. Gear          | 57. Gasket    | 86. Idler shaft        |
| 9. Thrust washer             | 20. Snap ring     | 58. Snap ring | 87. Retainer clip      |
| 10. Transmission input shaft |                   |               |                        |

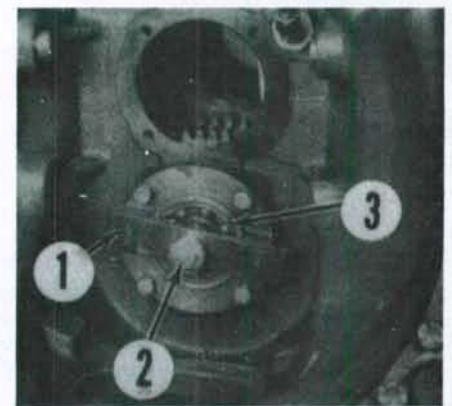

Fig. 131—Pto lower shaft is drilled and tapped at front end. Shaft can be pulled into bearing (3) using a pulser bar (1) and a cap screw and washer (2) as shown.

131. Apply nonhardening sealer to threads of retaining cap screws, then tighten to 60 N · m (45 ft.-lbs.) torque.

**COUNTERSHAFT**

**All Models So Equipped**

134. To remove countershaft (65—Fig. 129) and related gears, first remove pto lower shaft and gear as outlined in paragraph 133 and mainshaft and gears as outlined in paragraph 132. Remove snap rings (61 and 71) from front and rear of countershaft. Tap countershaft forward until free of rear bearing (70), then tap bearing rearward out of housing. Unseat snap ring (67) from groove in shaft and slide it forward onto unsplined section of shaft. Slide shaft rearward and remove two gears (62 and 63) from front of shaft, then move shaft forward and remove two gears (68 and 69) from rear of shaft. Withdraw countershaft with front bearing from housing.

To reinstall, insert countershaft from the front while installing rear gears with hubs positioned as shown in Fig. 132. Slide shaft rearward until front gears can be installed making sure hubs are positioned as shown in Fig. 132. Move snap ring (67—Fig. 129) into its groove in shaft. Position rear bearing (70) over shaft with outer snap ring on bearing towards the rear. Block front of countershaft as shown in Fig. 133, then drive bearing onto rear of shaft until snap ring can be installed. Install snap ring onto front of shaft. Complete installation by reversing the removal procedure.

**REVERSE IDLER ASSEMBLY**

**All Models So Equipped**

135. The reverse idler gear (84—Fig. 129) and shaft (86) can be removed from

Fig. 133—Block front of countershaft as shown when installing rear bearing onto shaft.

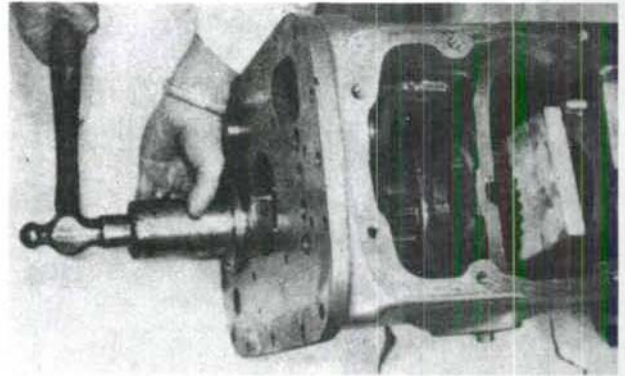
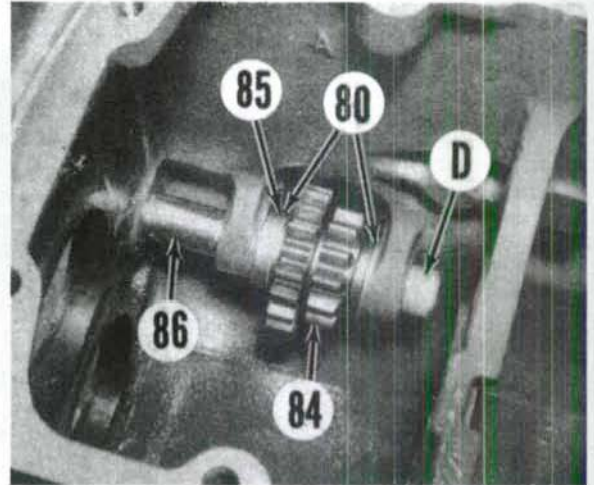

Fig. 134—Use a dummy shaft (D) to hold needle rollers in place in idler when removing and installing reverse idler gear assembly. Refer to text.

- 80. Thrust washers
- 84. Reverse idler gear
- 85. Spacer
- 86. Idler shaft



transmission housing after removing the mainshaft (17) and gears as outlined in paragraph 132.

The idler shaft (86) is retained in housing by a clip (87) and cap screw at rear face of transmission case. The cluster gear (84) contains two rows of loose needle rollers (28 each row). Use of a dummy shaft will facilitate removal and installation by preventing needle rollers from falling out of position. Dummy shaft can be made from 25 mm (1 inch) diameter

bar stock 55 mm (2-3/16 inches) long. Insert dummy shaft (D—Fig. 134) into front of gear to displace idler shaft, then lift out gear assembly, spacer (85) and thrust washers (80).

When reassembling, apply light coating of petroleum jelly to needle rollers and use dummy shaft to hold components in position in gear cluster. Insert idler shaft through gear to push dummy shaft out of the gear. Secure shaft with locking clip.

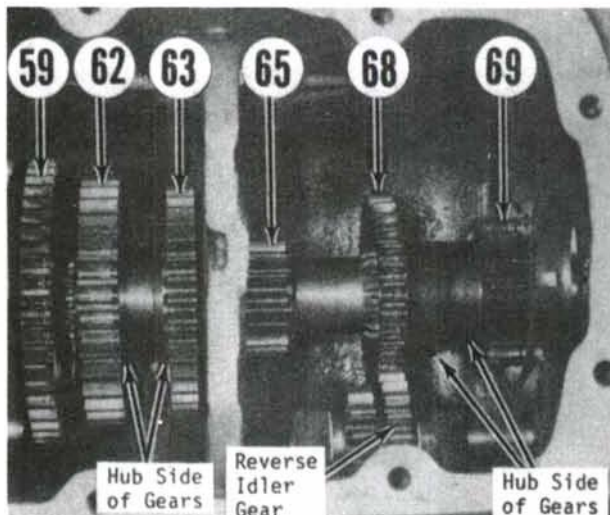

Fig. 132—View of countershaft and gears correctly assembled. Pto drive gear and countershaft constant mesh gears are shown at (59 and 62). First gear and second speed gears are shown at (65 and 69). Gears (63 and 68) are either third or fourth speed depending upon specific transmission.

**MANUAL SHUTTLE**

Models MF235, MF245 and MF250 may be equipped with a manual shuttle transmission which provides six forward and six reverse speeds.

**TRANSMISSION REMOVAL**

**All Models So Equipped**

136. To remove the manual shuttle transmission assembly, refer to paragraph 127 and follow the general procedure for eight-speed transmission removal.

SHIFTER RAILS AND FORKS

All Models So Equipped

137. To remove the shifter rails and forks, first remove transmission top cover and detach transmission from differential housing using paragraph 127 as a general guide. It is not necessary to remove transmission housing from engine.

Carefully remove detent springs and plungers. Remove safety wire and loosen all set screws from shift forks and planetary selector. Remove the planetary shift fork, then unbolt and remove the shift rail lock (Fig. 136) from rear of transmission. Pull the shuttle and planetary shift rail out rear of transmission and withdraw planetary selector and the shuttle fork (Fig. 135) from top. Slide the remaining two shift rails out of shift forks.

Observe the following when reassembling. Position the three transmission shift forks into gears as shown in Fig. 137. It may be necessary to move the shuttle coupling forward so that fork may be inserted into groove. The shift forks are not interchangeable. The left (2nd and 3rd gear) shift fork should have lug, set screw and shift notch all toward front as shown in Fig. 135. The notch and set screw will be toward front but lug will be toward rear of correctly installed right (1st gear) shift fork. Slide shift rails into forks. Shift rails are not

Fig. 137—Refer to text for correct installation of shift forks and rails.

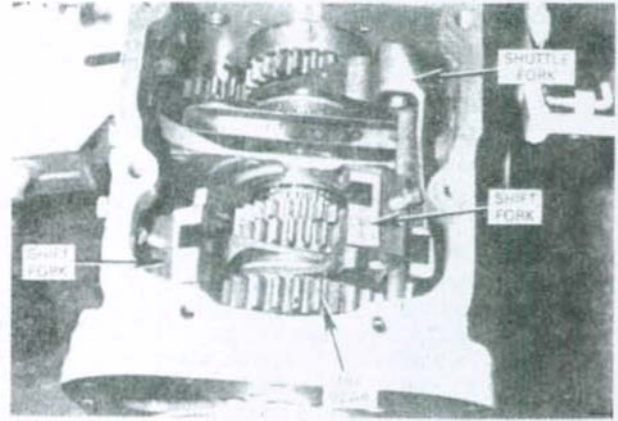

interchangeable. The two short rails should have notches for shift rail lock (Fig. 136) facing toward the interlock pin and flats toward top. Be sure set screws engage detent in shift rail, tighten screws and safety wire all set screws. Install the shift rail lock with interlock pin (Fig. 136). Spacer should be on longer screw at left as shown. Tighten both screws to 41-47 N·m (30-35 ft.-lbs. torque).

PLANETARY UNIT

All Models So Equipped

138. To remove planetary unit it is necessary to remove transmission top cover and separate transmission from differential housing using paragraph

127 as a general guide. It is not necessary to detach transmission from engine. Remove planetary shift fork and coupling from rear of planetary. Remove the four retaining cap screws, then withdraw rear cover plate (51—Fig. 139), thrust washer (43) and planet carrier (50). Pry ring gear (42) and dowels from transmission case. Remove front cover (41) and shim (40).

Planet pinion shafts (49) are a tight press fit in planet carrier (50). Use a suitable press to remove and install pinion shafts.

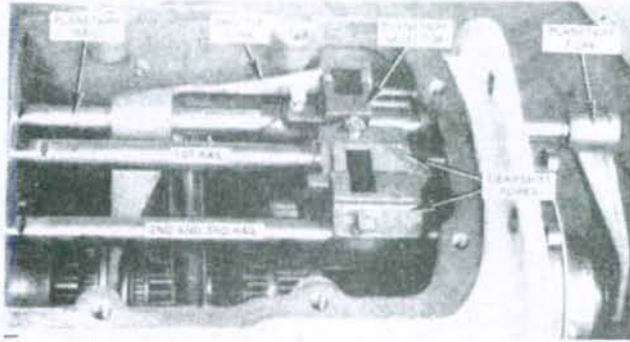

Fig. 135—View of shift rails and forks installed in manual shuttle transmission.

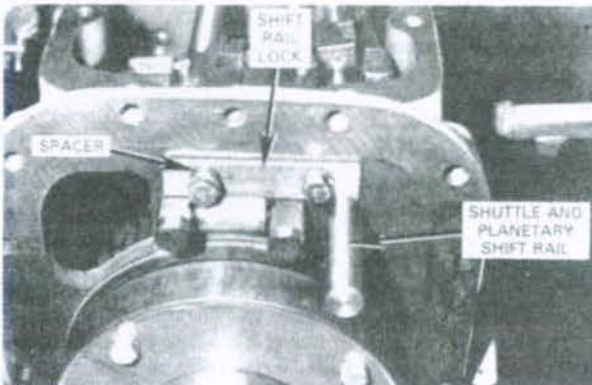

Fig. 136—View of the shift rail lock correctly installed. Spacer should be on the longer of the two screws at left.

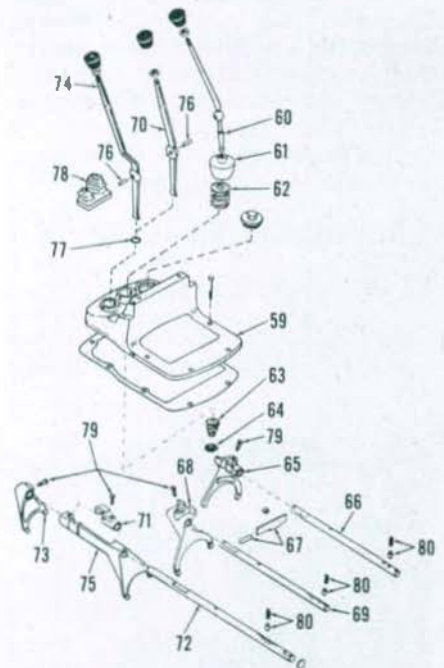

Fig. 138—Exploded view of shift levers, forks and rails for manual shuttle transmission.

- 59. Transmission top cover
- 60. Lever (1st, 2nd & 3rd)
- 61. Boot
- 62. Spring
- 63. Spring
- 64. Spring seat
- 65. Shift fork (2nd & 3rd)
- 66. Shift rail (2nd & 3rd)
- 67. Interlock
- 68. Shift fork (1st)
- 69. Shift rail (1st)
- 70. Lever (planetary)
- 71. Planetary selector
- 72. Shift rail (planetary)
- 73. Shift fork (planetary)
- 74. Shuttle lever
- 75. Shuttle fork
- 76. Pins
- 77. "O" ring
- 78. Boot
- 79. Set screws
- 80. Detents & springs

To reinstall planetary unit, reverse the removal procedure while noting the following special instructions: Install shim and front plate with slots aligned and pointing upward. Be sure tangs on thrust washers engage slots in carrier. Position rear plate with cutaway section at lower left-hand corner of ring gear. Tighten retaining cap screws evenly to 47 N · m (35 ft.-lbs.) torque.

**PTO INPUT SHAFT AND RETAINER**

**All Models So Equipped**

139. To remove pto input shaft (17—Fig. 141) and retainer (12), first separate transmission from engine as outlined in paragraph 112. Remove brake cross shaft, clutch release bearing, release lever and shafts from transmission housing.

**NOTE:** Check transmission input shaft (24) end play before removing pto input shaft. If end play exceeds 0.50 mm (0.020 inch), a new thrust washer (20) must be installed during reassembly to provide recommended end play of 0.25-0.50 mm (0.010-0.020 inch).

Unbolt retainer from front of transmission housing, then withdraw pto shaft and retainer while holding transmission input shaft in place in housing.

To disassemble the removed unit, unseat and remove large snap ring (Fig. 140) retaining bearing in retainer housing. Bump shaft and bearing rearward out of housing. Bearing can be removed from shaft after removing smaller snap ring.

Inspect seals (10 and 18—Fig. 141) and bearings (11 and 19) and renew if necessary. When installing needle bearings always press against lettered side of bearing. Seals should be installed with lip facing rearward. Be sure shielded side of bearing (15) is towards input shaft gear teeth. It is recommended that seal protector sleeves be placed over splined ends of transmission and pto shafts to avoid damaging oil seals during reassembly.

If transmission input shaft end play was excessive (checked prior to disassembly), select a thrust washer (20) of correct thickness to provide recommended end play and install over input shaft. If end play was not checked prior to disassembly, pto input shaft and retainer should be installed with original shim and end play checked with a dial indicator. If end play is excessive, remove pto input shaft and retainer and install proper thickness thrust washer. Specified shaft end play is 0.25-0.50 mm (0.010-0.020 inch).

When installing retainer and input shaft, coat threads of mounting cap screws with a nonhardening sealer. Tighten cap screws to 60 N · m (45 ft.-lbs.) torque.

**TRANSMISSION INPUT SHAFT AND FORWARD-REVERSE GEAR CLUSTER**

**All Models So Equipped**

140. To remove transmission input shaft (24—Fig. 141), first remove transmission assembly from tractor using paragraph 127 as a general guide. Remove shifter rails and forks as outlined in paragraph 137. Remove brake cross shaft and clutch release bearing and fork from front of transmission housing.

Move pto lower shaft rearward to permit pto constant mesh gear (69) to drop to bottom of transmission case as follows: Remove cover (60) from front of housing, then remove snap ring (63) from front of pto shaft. Thread two cap screws into tapped holes in bearing retainer (66) and tighten evenly to pull retainer with bearing (65) from pto shaft. Pull pto shaft rearward until constant mesh gear drops to bottom of case to provide clearance for input shaft removal.

**NOTE:** Prior to removal of pto input shaft (17), measure transmission input shaft end play using a dial indicator, or measure clearance between reverse gear (21) and thrust washer (20) using a feeler gage. Record the measurement for use in

reassembly. Specified end play is 0.25-0.50 mm (0.010-0.020 Inch).

Remove bearing retainer (12) mounting cap screws, then withdraw retainer with pto input shaft (17) while holding transmission input shaft and forward-reverse gear cluster in place in transmission case. Carefully move input shaft and gear cluster forward to disengage input shaft from mainshaft (34). Note that 23 loose needle bearings are contained in rear of input shaft and they may fall out when shaft is removed. Move rear of input shaft with gear cluster upward and rearward out top of transmission case.

**NOTE:** The forward-reverse gear cluster contains 240 loose needle rollers. Be sure to keep gear cluster in position on input shaft during removal from housing to avoid dropping rollers into transmission housing.

Slide reverse gear (21) and forward gears (29) with needle rollers and spacer washers off input shaft. Remove shift collar (28), springs and detents (24) from shaft. Remove spacers (26) and needle rollers (27) from input shaft bore if necessary.

To reassemble, reverse the disassembly procedure while noting the following special instructions: Be sure to account for all the needle rollers (23) in forward and reverse gears (two rows of 60 rollers in each gear) and rollers (27) in input shaft (one row of 23 rollers). Use petroleum jelly to hold rollers and spacers in position.

If transmission input shaft end play (measured prior to disassembly) was not within specified range of 0.25-0.50 mm (0.010-0.020 inch), select thrust washer (20) of correct thickness to provide recom-

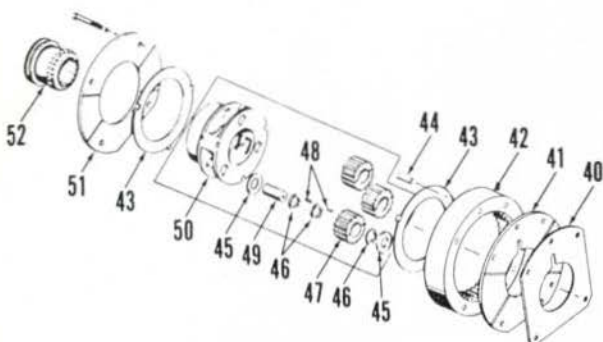

**Fig. 139—Exploded view of planetary assembly used with manual shuttle transmissions.**

- 40. Shim
- 41. Front plate
- 42. Ring gear
- 43. Thrust washer
- 44. Dowel
- 45. Thrust washer
- 46. Washers
- 47. Planet gears
- 48. Needle rollers
- 49. Shaft
- 50. Planet carrier
- 51. Rear plate
- 52. Shift coupler

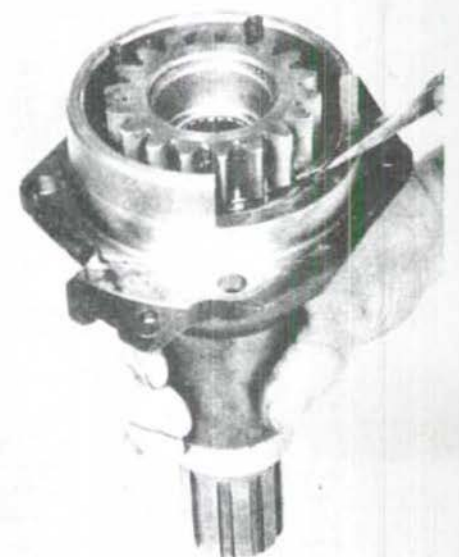

**Fig. 140—Snap ring at gear end of pto input shaft retains shaft and bearing in retainer housing.**



mended clearance. Only one thrust washer must be installed. If end play was not checked prior to disassembly, it will be necessary to reinstall main input shaft with original thrust washer, pto input shaft and retainer housing. Check input shaft end play using a dial indicator, or measure clearance between reverse gear (21) and thrust washer using a feeler gage. Then, if necessary, disassemble input shaft and install cor-

rect thickness thrust washer to obtain specified end clearance.

It is recommended that a suitable seal protector sleeve installed over splined end of transmission input shaft to avoid damaging oil seal when assembling pto input shaft over the transmission shaft. Apply suitable nonhardening sealer to threads of bearing retainer cap screws, then tighten to 60 N·m (45 ft.-lbs.) torque.

**REVERSE IDLER ASSEMBLY**

**All Models So Equipped**

141. To remove reverse idler gear (8—Fig. 141), first remove pto input shaft and transmission input shaft as outlined in paragraph 140. Remove oil trough (30) from front of mainshaft. The right-hand clutch release fork shaft (Fig. 142) can be used as a dummy shaft to remove and install idler gear and shaft. A dummy shaft can also be made from hard plastic, wood or steel bar stock 25 mm (1 inch) in diameter and 100 mm (4 inches) long. Insert dummy shaft into idler gear from the rear and push idler shaft out of gear and housing. Remove idler gear assembly being careful not to drop needle rollers (6—Fig. 141).

There is a total of 46 needle rollers (23 per path) contained in idler gear. When reassembling, use petroleum jelly and a dummy shaft to hold components in place. Position idler gear in housing with larger gear forward. Slide idler shaft into housing and gear making sure that roll pin (2) in end of shaft and oil hole (Fig. 142) in shaft are positioned upward. Note that idler shaft on some models may have a notched section on front of shaft that aligns with input shaft housing instead of roll pin.

**MAINSHAFT AND SLIDING GEARS**

**All Models So Equipped**

142. To remove mainshaft (34—Fig. 141), first remove transmission as outlined in paragraph 127. Remove shifter rails and forks as outlined in paragraph 137, rear planetary as outlined in paragraph 138 and transmission input shaft as outlined in paragraph 140.

Tap mainshaft rearward to force front bearing (31) from shaft. Continue to slide shaft out the rear while removing gears (32 and 33). Note that rear bearing (36) must be removed and installed over forward end of shaft.

To reinstall shaft, reverse the removal procedure. Be sure that large external snap ring on rear bearing is towards rear of shaft and that sliding gears are positioned with shift fork grooves facing each other. Refer to Fig. 143.

**PTO LOWER SHAFT AND DRIVE GEAR**

**All Models So Equipped**

143. To remove pto lower shaft (70—Fig. 141) and drive gear (69), transmission must first be removed as outlined in paragraph 127. Remove brake cross shaft and clutch release linkage and throwout bearing from front

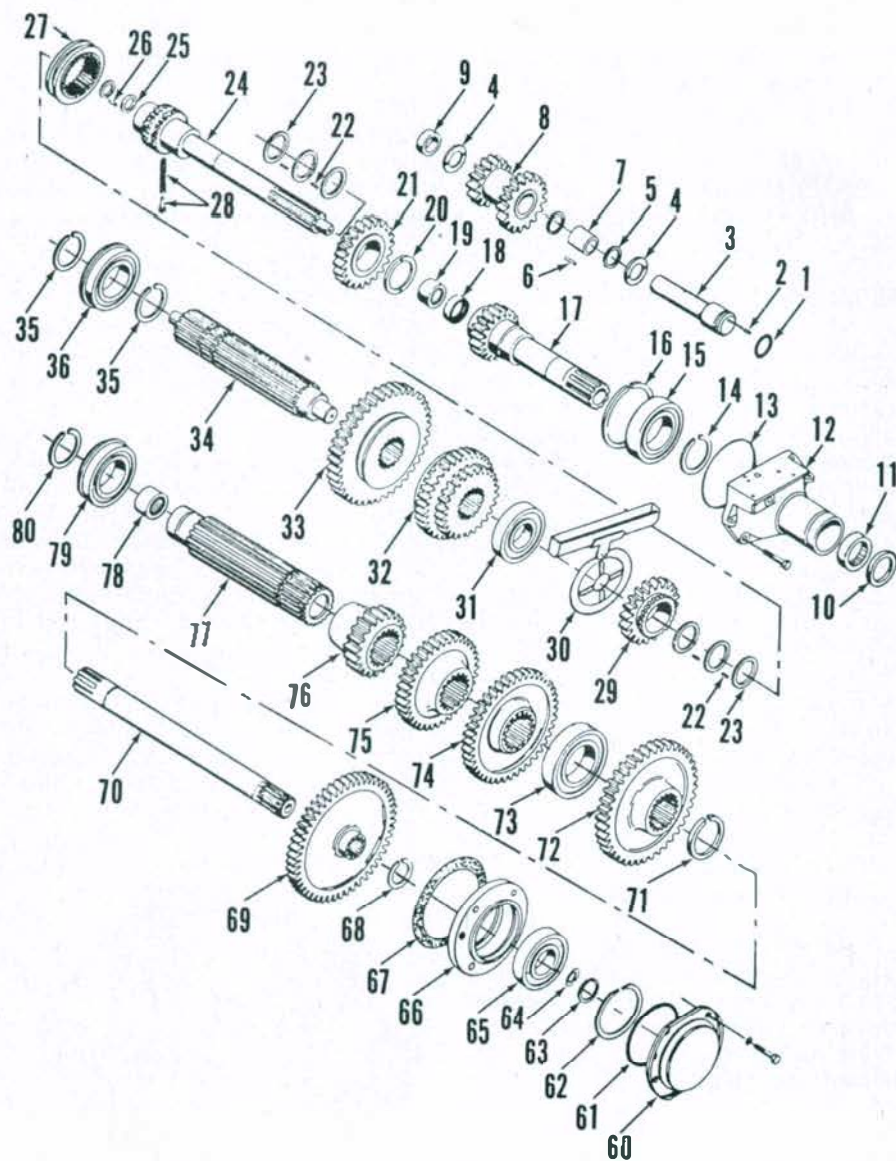

Fig. 141—Exploded view of manual shuttle transmission input shafts, mainshaft, reverse idler, pto lower shaft, countershaft and related components. Planetary unit is shown in Fig. 139.

- |                       |                              |                              |                             |
|-----------------------|------------------------------|------------------------------|-----------------------------|
| 1. "O" ring           | 17. Pto input shaft          | 30. Oil trough & spacer      | 67. Gasket                  |
| 2. Pin                | 18. Oil seal                 | 31. Bearing                  | 68. Snap ring               |
| 3. Idler shaft        | 19. Bearing                  | 32. Sliding gear (2nd & 3rd) | 69. Pto drive gear          |
| 4. Thrust washer      | 20. Thrust washer            | 33. Sliding gear (1st)       | 70. Pto lower shaft         |
| 6. Washer             | 21. Reverse gear             | 34. Mainshaft                | 71. Snap ring               |
| 6. Needle rollers     | 22. Needle rollers           | 35. Snap rings               | 72. Countershaft drive gear |
| 7. Spacer             | 23. Washer                   | 36. Bearing                  | 73. Bearing                 |
| 8. Reverse idler gear | 24. Transmission input shaft | 60. Cover                    | 74. Gear (3rd)              |
| 9. Spacer             | 25. Washers                  | 61. "O" ring                 | 75. Gear (2nd)              |
| 10. Oil seal          | 26. Needle rollers           | 62. Snap ring                | 76. Gear (1st)              |
| 11. Bearing           | 27. Shift collar             | 63. Snap ring                | 77. Countershaft            |
| 12. Retainer housing  | 28. Detent plunger & spring  | 64. Washer                   | 78. Bearing                 |
| 13. "O" ring          | 29. Forward gear             | 65. Bearing                  | 79. Bearing                 |
| 14. Snap ring         |                              | 66. Retainer housing         | 80. Snap ring               |

of transmission housing. Remove front cover plate (60), and remove snap ring (63) from front of pto shaft. Thread two cap screws into tapped holes of bearing retainer (66) and tighten evenly to force retainer with bearing from the shaft. Withdraw pto shaft rearward from housing. Remove pto input shaft and transmission input shaft as outlined in paragraph 140. Remove pto drive gear out top opening of housing.

To reinstall, reverse the disassembly procedure while noting the following special instructions: Be sure that hub side of pto gear faces forward. Front end of pto shaft contains a threaded hole which can be used to pull shaft into front bearing. Apply nonhardening sealer to threads of retainer cover cap screws, then tighten to 60 N · m (45 ft.-lbs.) torque.

### COUNTERSHAFT

#### All Models So Equipped

144. To remove countershaft (77—Fig. 141) and gears, remove input shafts and retainer as outlined in paragraph 140 and remove mainshaft and gears as outlined in paragraph 142. Withdraw pto lower shaft from housing and remove drive gear as outlined in paragraph 143. Remove snap ring (71) from front of countershaft and remove constant mesh gear (72) out top of transmission housing. Remove snap ring (80) from rear of shaft, then tap shaft forward until free from rear bearing. Slide countershaft forward from housing while removing gears (74, 75 and 76) out top of housing.

To reinstall, reverse the removal procedure. Position gear (74) with beveled

Fig. 142—The right side half of clutch release fork shaft can be polished and used as a dummy shaft to remove and install reverse idler gear.

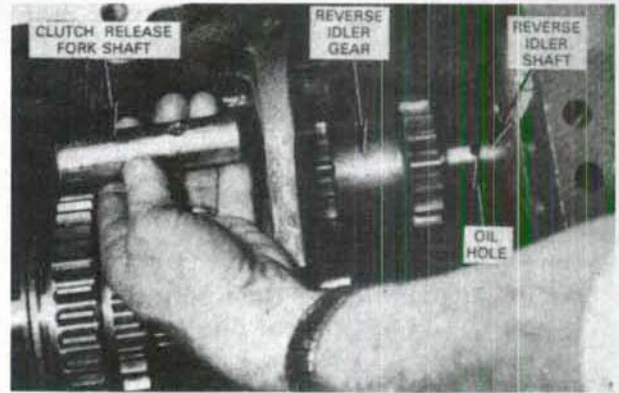
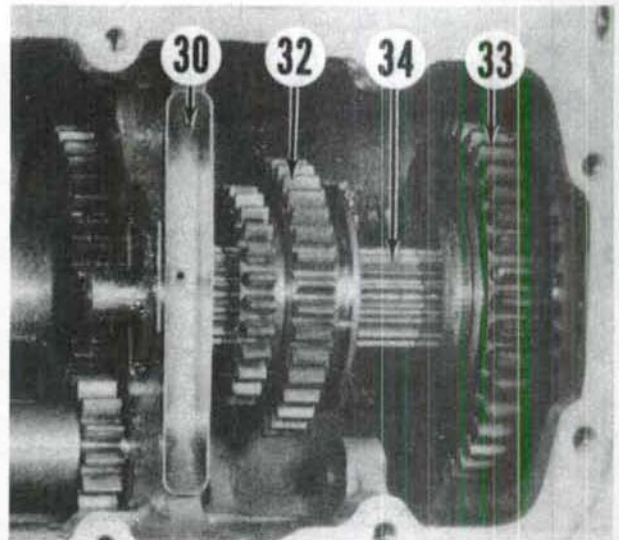

Fig. 143—View of mainshaft showing correct installation of sliding gears. Refer to Fig. 141 for legend.



edge of teeth and hub facing rearward, position middle gear (75) with beveled edge of teeth and hub facing forward and install rear gear (76) with beveled edge of teeth and hub facing rearward.

shift control rod. Disconnect throttle linkage from cross shaft, then unbolt and remove the battery support and air cleaner. Attach hoist to transmission top cover, then unbolt and lift cover from top of transmission case. Disconnect hydraulic line inside transmission compartment. Unbolt the clutch pedal bracket, attach hoist to transmission and support differential housing. Unbolt transmission from differential housing. Install guide studs and carefully slide transmission forward away from differential housing.

Rejoin transmission to differential housing completely before tightening the retaining screws. It may be necessary to reach through opening for the response control cover and turn the pto coupling before transmission will slide up to differential housing. Tighten the screws attaching differential housing to transmission housing to 75 N · m (55 ft.-lbs.) torque. Be sure hydraulic line in transmission is reconnected. Transmission should be in neutral before installing shift cover. Make sure shift levers engage shift rails. Tighten cover retaining screws to 47 N · m (35 ft.-lbs.) torque. Refer to paragraph 146 for adjustment of Multi-Power control linkage.

## MULTI-POWER TRANSMISSION

All MF235 and MF245 models may be equipped with a Multi-Power transmission. The Multi-Power transmission is a gear change transmission with six forward speeds and two reverse speeds which is additionally equipped with a hydraulically operated high-low range unit which may be shifted while tractor is moving under load. Many of the service procedures and some parts may be similar to six- or eight-speed transmissions; however, refer to the following paragraphs for service to Multi-Power transmission.

### TRANSMISSION REMOVAL

#### All Models So Equipped

145. To remove the complete Multi-Power transmission unit from the tractor, first drain the transmission and hydraulic system fluid and separate the engine from transmission housing as outlined in paragraph 112. Remove both step plates, disconnect clutch rod and both brake rods. Remove the battery. Disconnect neutral starting switch, wiring to fender lights and the Multi-Power

SHIFT LINKAGE

All Models So Equipped

146. Multi-Power shift control valve spool must move fully to high and low positions as hand control lever (10—Fig. 144) is moved to top and bottom of slot in instrument panel. To adjust linkage, move hand control lever towards "HIGH" position until front of lever is within 1.6 mm (1/16 inch) from top edge of quadrant slot. Loosen clamp bolt securing link (6) to lower rod (4), then push lower rod downward as far as it will go. Retighten clamping bolt to lock the adjustment.

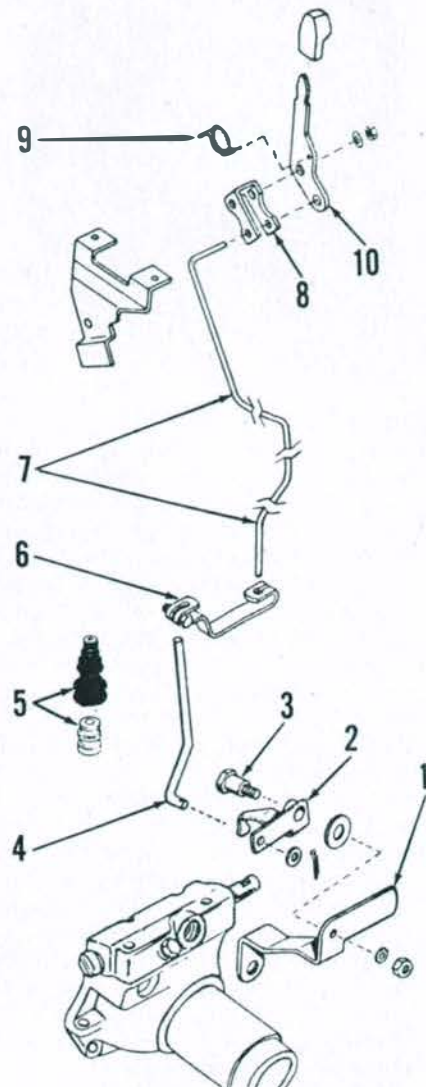

Fig. 144—Exploded view of Multi-Power shift control linkage and associated parts.

- |                   |                   |
|-------------------|-------------------|
| 1. Bracket        | 6. Link           |
| 2. Shift lever    | 7. Upper link rod |
| 3. Pivot bolt     | 8. Spacer         |
| 4. Lower link rod | 9. Spring         |
| 5. Bushing & boot | 10. Lever         |

SHIFT CONTROL VALVE

All Models So Equipped

147. REMOVE AND REINSTALL. To remove the Multi-Power control valve, first detach engine from transmission housing as outlined in paragraph 112. Remove clutch release bearing, release fork and pivot shafts. Disconnect Multi-Power shift linkage and oil inlet tube. Unbolt and remove shift lever bracket and linkage assembly. Remove retaining cap screws, then withdraw shaft retainer, pto input shaft and valve housing as a unit from transmission housing.

NOTE: The clutch unit prevents removal of transmission shaft until transmission is disassembled.

When detaching control valve from retainer, note that left, front mounting screw is sealed with a copper washer. Make sure this washer is reinstalled in the correct location when unit is reassembled.

Use a new gasket (2—Fig. 145) when reinstalling valve. Make sure the long cap screw with copper sealing washer is installed in the correct hole and tighten all screws evenly to a torque of 4.1-5.4 N·m (36-48 in.-lbs.). Tighten the four screws that attach housing (1) to transmission to 54-61 N·m (40-45 ft.-lbs.) torque.

148. OVERHAUL. To overhaul the removed "Multi-Power" control valve, refer to Fig. 145 and proceed as follows:

Remove fitting (4) and detent assembly (13), then withdraw shift valve (7). Remove plug (12), washer (11) and spring

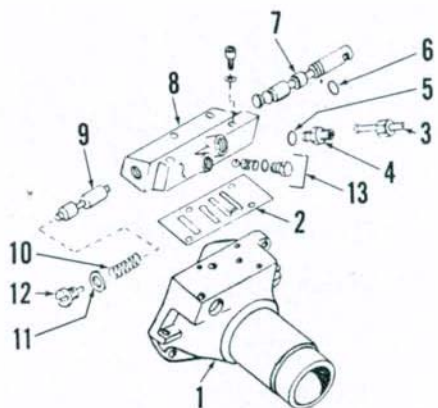

Fig. 145—Exploded view of Multi-Power shift control valve and associated parts.

- |                  |                     |
|------------------|---------------------|
| 1. Housing       | 8. Valve body       |
| 2. Gasket        | 9. Regulating valve |
| 3. Pressure line | 10. Spring          |
| 4. Fitting       | 11. Gasket          |
| 5. "O" ring      | 12. Plug            |
| 6. "O" ring      | 13. Detent assy.    |
| 7. Shift valve   |                     |

(10), then bump valve body (8) against a wooden block, if necessary, to dislodge regulating valve (9) from its bore.

Clean all parts in a suitable solvent. Discard "O" rings (5 and 6) when reassembling. Carefully examine all parts for wear, scoring or other damage. All parts are available individually.

When reassembling the valve unit, make sure regulating valve spool (9) is installed "V" notched end first. Tighten plug (12) to a torque of 23-30 N·m (17-22 ft.-lbs.).

NOTE: Shift valve (7) must be inserted before fitting (4) is installed.

TRANSMISSION TOP COVER

All Models So Equipped

149. To remove the transmission top cover, first remove hood and battery. Disconnect drag links and power steering hoses if so equipped. Unbolt and remove the battery support and the air cleaner. Disconnect interfering control rods, cables, wires and tubes, then unbolt the cover from top of transmission. Notice that two screws are located at front edge of top cover. Install guide studs, attach hoist and carefully raise top cover.

When reinstalling, place all gears in neutral and be sure detent pins and springs are correctly positioned under gasket. Lower cover into position over the guide studs making sure levers engage shift rails. Tighten cover screws to 47 N·m (35 ft.-lbs.) torque.

SHIFTER RAILS AND FORKS

All Models So Equipped

150. To remove the shifter rails and forks, first remove transmission top cover as outlined in paragraph 149 and detach

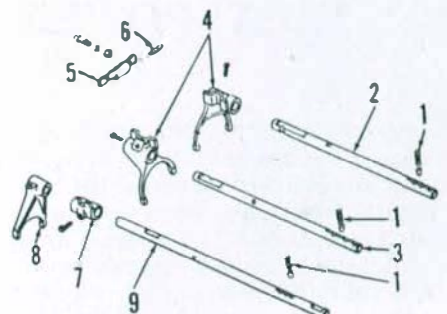

Fig. 146—Exploded view of transmission shifter rails, forks and associated parts typical of Multi-Power (12-speed) models.

- |                     |                         |
|---------------------|-------------------------|
| 1. Shift detents    | 6. Interlock pin        |
| 2. Second/high rail | 7. Selector             |
| 3. Low/reverse rail | 8. Planetary shift fork |
| 4. Shift forks      | 9. Planetary shift rail |
| 5. Stop plate       |                         |

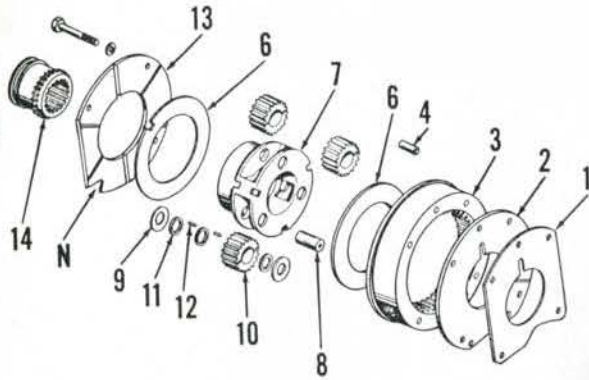

Fig. 147—Exploded view of planetary assembly used on Multi-Power models. Notched section (N) of rear cover is installed over bottom right-hand mounting bolt hole.

1. Front shim
2. Front plate
3. Ring gear
4. Dowel
5. Thrust washer
6. Planet carrier
7. Pinion shaft
8. Pinion
9. Thrust washer
10. Spacer washer
11. Needle rollers
12. Rear plate
13. Shift coupler

transmission from differential housing, using paragraph 145 as a guide. It is not necessary to separate transmission from engine. Unwire and remove the set screws retaining selector and shifter forks to rails. Remove detent spring and plunger assemblies (1—Fig. 146) and stop plate (5), then withdraw shifter rails and forks from transmission case. Forks (4) are interchangeable, but rails (2 and 3) are not. Rails should be installed with milled flat to top rear and selector lock grooves to center. Interlock pin (6) prevents the movement of the other rail when either selector rail is moved from the neutral position.

When assembling, slide center shift rail into case and through the selector and shift fork. Tighten selector set screw and install safety wire. Rotate rail until shift fork set screw can be tightened fully, then install safety wire. Install the left shift rail and fork, then right shift rail and fork into respective bores, tighten set screws and install safety wire. Slide the planetary shift rail through rear of case and locate fork over end with set screw to the outside. Slide rail forward into case and into selector. Tighten set screws and install safety wire. Be sure that interlocking pin is through the center rail and that all rails are in "NEUTRAL." Install steel balls in lock mechanism and locate at rear of case. The steel balls should be at both ends of the center rail interlock pin and the widest flat of lockplate should be over planetary rail. Tighten screws attaching the interlock mechanism to 47 N·m (35 ft.-lbs.) torque. Locate the planetary shift fork into groove of planetary coupler, then slide coupler into planetary while piloting shift fork over the rail. Tighten set screws and safety wire in place.

housing using paragraph 145 as a general guide. Remove the planetary shift fork and coupling (14—Fig. 147) from rear of transmission case. Remove the four retaining screws and withdraw rear cover (13), rear thrust washer (6) and planet carrier (7). Work planetary ring gear (3) and dowels (4) from case using screwdrivers. Remove planetary front cover (2) and shim (1).

Planet pinion shafts (8) are a tight press fit in planet carrier (7). Use a suitable press for removing and installing pinion shafts.

Assemble and install unit as follows: Apply a light coat of grease to one side of thrust washers (9), bearing needles (12) and spacer washers (11). Position one thrust washer (9) on bench with greased side up and locate pinion (10) over the washer. Install one spacer (11) in pinion, followed by one row of needles (12), a spacer (11), the second row of needles and the third spacer (11) and thrust washer (9). Assemble the two remaining pinions in the same way. Position the carrier (7) in a press with the hub side down, install the pinion with bearings and washers, then press pinion shaft into carrier until flush.

Position front plate (2) on ring gear (3) with oil grooves toward inside. Install shim (1) with slots on shim and front plate aligned and toward top when assembled to rear of case. Tap into position on rear case to be sure dowels are fully into case. Use a light coat of grease

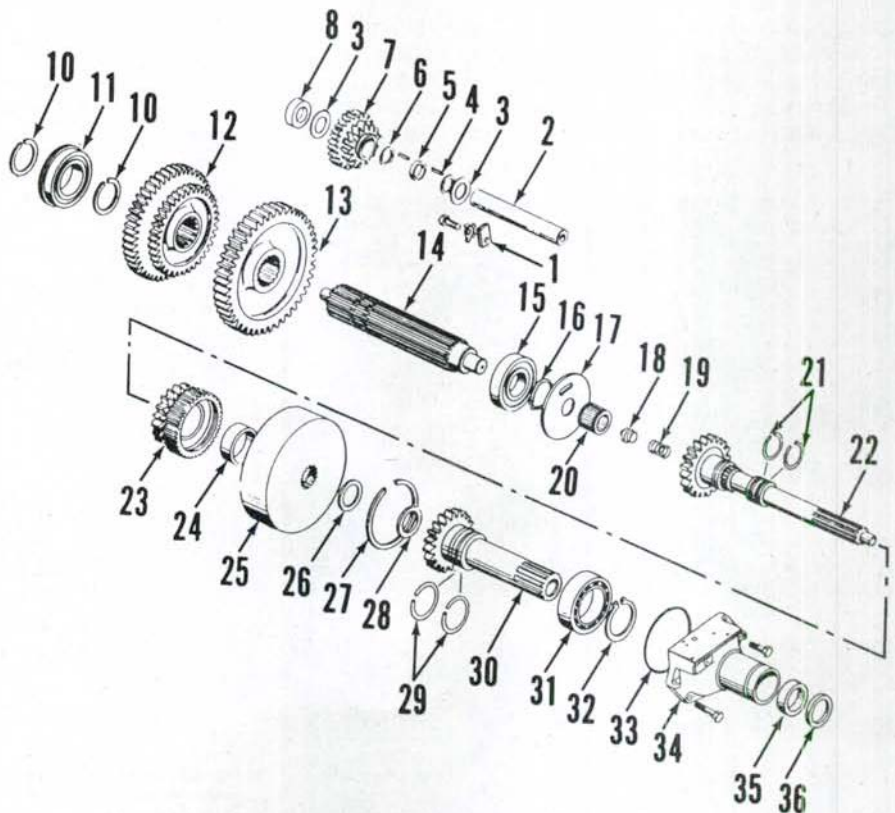

Fig. 148—Exploded view of transmission upper shafts and associated parts, reverse idler gear assembly and Multi-Power clutch unit.

- |                       |                       |                              |                      |
|-----------------------|-----------------------|------------------------------|----------------------|
| 1. Retainer clip      | 11. Bearing           | 20. Bearing                  | 27. Snap ring        |
| 2. Idler shaft        | 12. Gear (2nd & 3rd)  | 21. Seal rings               | 28. Oil seal         |
| 3. Thrust washers     | 13. Gear (1st & rev.) | 22. Transmission input shaft | 29. Seal rings       |
| 4. Needle rollers     | 14. Mainshaft         | 23. Overdrive pinion gear    | 30. Pto input shaft  |
| 5. Spacer             | 15. Bearing           | 24. Bushing                  | 31. Bearing          |
| 6. Washer             | 16. Snap ring         | 25. Multi-Power clutch unit  | 32. Snap ring        |
| 7. Reverse idler gear | 17. Spring            | 26. Thrust washer            | 33. "O" ring         |
| 8. Spacer             |                       |                              | 34. Retainer housing |
| 9. Snap rings         |                       |                              | 35. Bearing          |
|                       |                       |                              | 36. Oil seal         |

**PLANETARY UNIT**

**All Models So Equipped**

151. To remove the planetary unit, first detach transmission from differential

to hold thrust washer (6) to the front of carrier (7) making sure tangs on washer engage notches of carrier. Insert carrier assembly into ring gear carefully so thrust washer doesn't fail. Make sure carrier is fully into ring gear and over main shaft. Install the remaining thrust washer making sure tangs engage notches of carrier. Install rear cover plate (13) with oil grooves inward. The notched lower section (N) of cover plate should be over the bottom right-hand mounting bolt hole. Install the bottom left-hand mounting bolt without lockwasher. Install the three remaining bolts with lockwashers, then torque all four mounting bolts to 41.47 N · m (30.35 ft.-lbs.). Complete assembly by reversing removal procedure.

Fig. 151—Exploded view of Multi-Power clutch assembly.

1. Overdrive pinion
2. Snap ring
3. Retainer plate
4. Friction discs
5. Drive plates
6. Return springs
7. Piston
8. Outer seal ring
9. Inner seal ring
10. Clutch housing

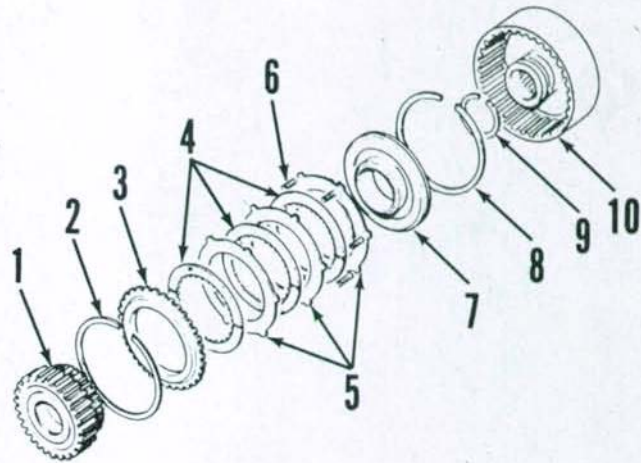

**MAINSHAFT**

**All Models So Equipped**

152. To remove mainshaft (14—Fig. 148) and sliding gears, first remove planetary unit as outlined in paragraph 151 and shifter rails and forks as outlined in paragraph 150. Move low speed sliding gear (13) forward until groove in mainshaft splines is exposed. Insert a large blade screwdriver into the groove to hold gear in position, then insert a pry bar between front of gear and transmission housing wall as shown in Fig. 149. Pry shaft rearward until front bearing

is free from housing bore. Remove snap ring (16—Fig. 148), then pull mainshaft rearward to bump bearing from front of shaft. Remove gears (13 and 12) as shaft is withdrawn rearward. Note that rear bearing (11) is removed and installed over front end of mainshaft.

When reinstalling, be sure that cluster gear (12) is positioned with smaller gear facing forward and that first-reverse gear (13) is positioned with shift fork groove towards the rear. Insert a spacer between front bearing and wall of transmission case (Fig. 150), then tap rear of mainshaft with a soft hammer until bearing is seated against shoulder of shaft. Com-

plete installation by reversing the removal procedure.

**PTO INPUT SHAFT AND RETAINER**

**All Models So Equipped**

153. To remove pto input shaft (30—Fig. 148) and retainer (34), first separate transmission from engine as outlined in paragraph 112. Remove clutch throwout bearing, release fork and shafts from front of transmission housing. Disconnect Multi-Power control linkage and hydraulic line. Remove retainer housing cap screws, then withdraw retainer with input shaft as a unit from transmission case.

Remove large snap ring (27) at rear of retainer, then bump shaft and bearing rearward from retainer.

Inspect all parts for wear or damage and renew if necessary. Oil seals (28 and 36) are installed with lips facing rearward. Be sure shield side of bearing (31) is towards gear end of input shaft.

Lubricate all parts with transmission oil prior to assembly. Use suitable seal protector sleeves over splined end of input shafts to avoid damaging oil seals during reassembly. Apply nonhardening sealer to threads of retainer housing cap screws, then tighten to 60 N · m (45 ft.-lbs.) torque.

**TRANSMISSION INPUT SHAFT AND MULTI-POWER CLUTCH**

**All Models So Equipped**

154. **R&R AND OVERHAUL.** To remove transmission input shaft (22—Fig. 148) and Multi-Power clutch (25), first remove transmission from tractor as outlined in paragraph 145. Remove pto input shaft and retainer housing as outlined in paragraph 153 and remove mainshaft as outlined in paragraph 152.

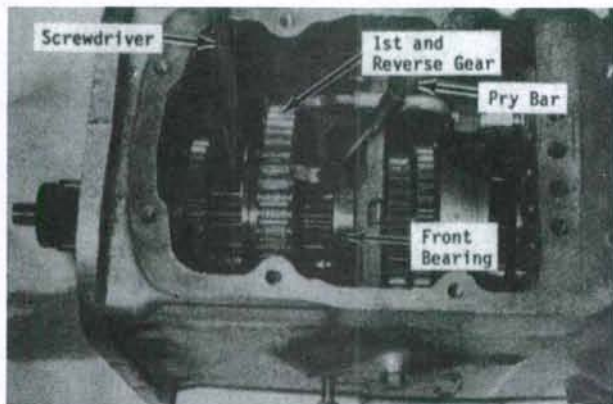

Fig. 149—Pry mainshaft rearward to free front bearing from housing bore.

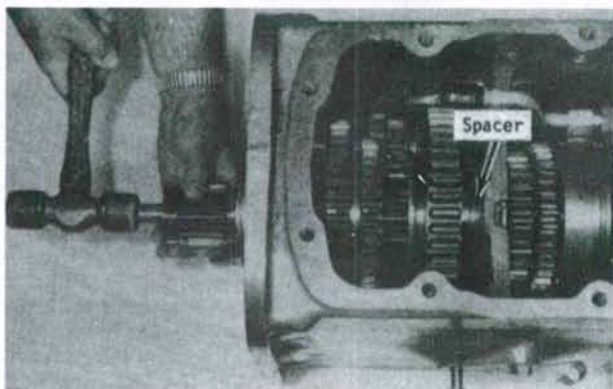

Fig. 150—Insert a spacer between mainshaft front bearing and transmission housing wall, then tap mainshaft into housing.

Move transmission input shaft forward slightly and remove spacer plate (17). Withdraw input shaft rearward from transmission case while sliding clutch assembly (25) and overdrive pinion (23) off the shaft. Inspect needle bearing (20), sealing rings (21) and input shaft for wear or damage and renew if necessary.

To disassemble the removed Multi-Power clutch unit, place clutch assembly on a clean bench with overdrive pinion (1— Fig. 151) up. Push down on clutch retainer plate (3) to compress return springs, then remove snap ring (2) with a narrow blade screwdriver. Remove all components from clutch housing (10) and examine for wear, scoring or other damage. Renew clutch sealing rings (8 and 9) whenever clutch is disassembled.

Renew any components that show signs of wear, damage, distortion or overheating. Thickness of friction discs (4) when new is 2.41-2.59 mm (0.095-0.102 inch). Thickness of driving plates (5) when new is 1.67-1.75 mm (0.660-0.690 inch). Friction discs and drive plates must be renewed as a complete set.

When reinstalling piston (7), carefully compress outer seal ring (8) using a feeler gage blade or similar tool while working piston into clutch housing. When assembling clutch plates, note that clutch housing contains six bleed holes (B—Fig. 152) that are evenly spaced around the housing and that drive plates have six external lugs (L) located one spline to the right (clockwise) from bleed holes. Place the six piston return springs on the lugs of the first drive plate. Install friction discs and remaining two drive plates alternately, staggering the lugs of each plate one spline further to the right of the plate previously installed as shown in Fig. 152. Make certain that return springs contact only the first plate, then install retainer (3—Fig. 151) and snap ring (2).

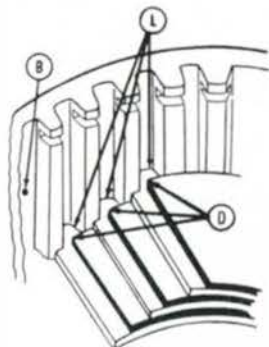

Fig. 152—Cross-sectional view of Multi-Power clutch showing recommended method of assembly. Refer to text.

B. Bleed hole  
D. Clutch discs  
L. Drive lugs on clutch plate

To reinstall clutch unit and input shaft, reverse the removal procedure.

### PTO LOWER SHAFT AND DRIVE GEAR

#### All Models So Equipped

155. To remove pto lower shaft (11—Fig. 153), first remove transmission assembly as outlined in paragraph 145. Remove clutch throwout bearing, fork and shaft and the brake pedal cross shaft from front of pto shaft. Thread two cap screws into tapped holes in bearing retainer (7) and tighten evenly to force retainer with bearing off front of shaft. Withdraw pto shaft rearward from transmission housing. Pto drive gear (10) can be removed from housing after removing mainshaft as outlined in paragraph 152 and transmission input shaft as outlined in paragraph 154.

To reinstall, reverse the removal procedure. Front end of pto shaft contains a threaded hole that can be used to pull shaft into front bearing as shown in Fig. 154. Apply nonhardening sealer to threads of retainer and cover mounting

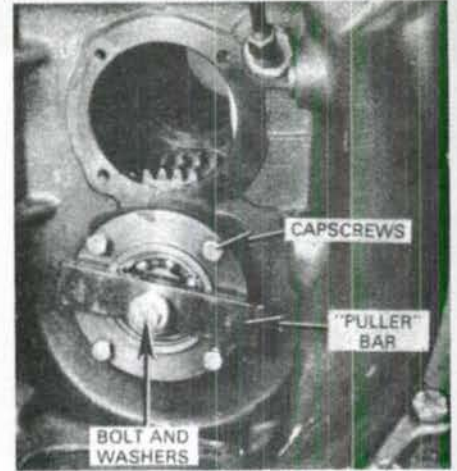

Fig. 154—Pto lower shaft is drilled and tapped at front end for installation as shown.

cap screws, then tighten to 60 N·m (45 ft.-lbs.) torque.

### COUNTERSHAFT

#### All Models So Equipped

156. To remove countershaft (20—Fig. 153), first remove transmission assembly

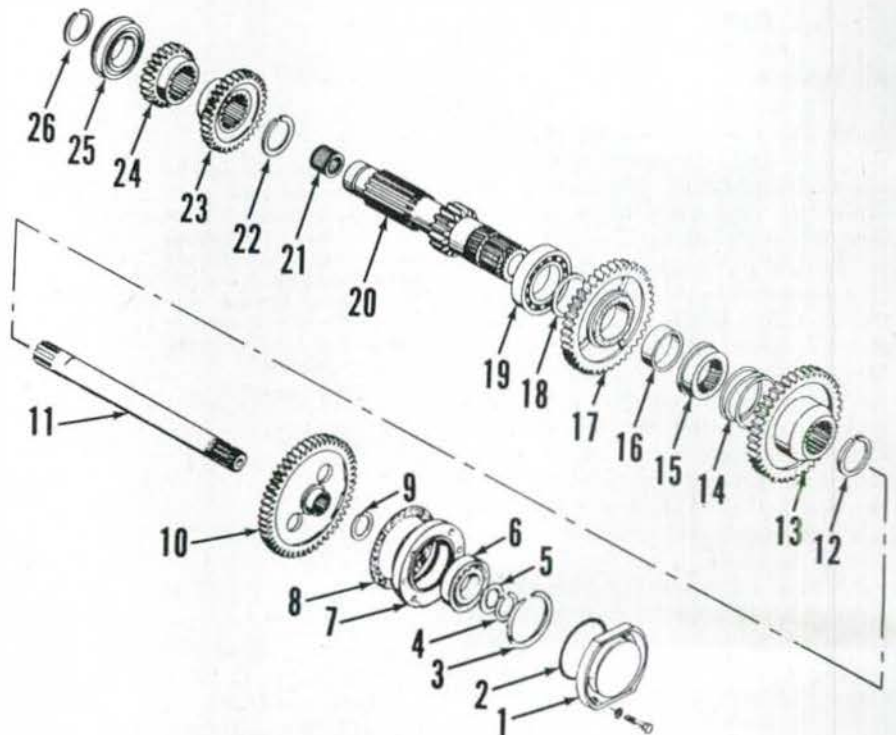

Fig. 153—Exploded view of lower pto shaft and transmission countershaft with associated parts used in Multi-Power transmission.

- |              |                     |                       |                  |
|--------------|---------------------|-----------------------|------------------|
| 1. Cover     | 8. Gasket           | 14. Spring            | 20. Countershaft |
| 2. "O" ring  | 9. Snap ring        | 15. Coupler           | 21. Bearing      |
| 3. Snap ring | 10. Pto drive gear  | 16. Bushing           | 22. Snap ring    |
| 4. Snap ring | 11. Pto lower shaft | 17. Direct drive gear | 23. Gear (3rd)   |
| 5. Washer    | 12. Snap ring       | 18. Thrust washer     | 24. Gear (2nd)   |
| 6. Bearing   | 13. Overdrive gear  | 19. Bearing           | 25. Bearing      |
| 7. Retainer  |                     |                       | 26. Snap ring    |

as outlined in paragraph 145. Remove mainshaft and gears as outlined in paragraph 152, transmission input shaft as outlined in paragraph 154 and pto lower shaft and drive gear as outlined in paragraph 155. Remove snap ring (26) from rear of countershaft, then tap shaft forward until free from rear bearing (25). Unseat snap ring (22) from groove of countershaft and move it forward onto unsplined area of shaft. Use a suitable clamp around overdrive gear (13) and direct drive gear (17) to compress coupler spring (14). Remove snap ring (12), then move shaft rearward to allow removal of overdrive gear and direct drive gear from shaft. Countershaft can now be

withdraw forward from transmission case and gears (23 and 24) lifted out of top opening.

To reinstall, reverse the removal procedure.

**REVERSE IDLER GEAR**

**All Models So Equipped**

157. The reverse idler shaft (2—Fig. 148) and gear assembly (7) can be removed from transmission housing after removing the mainshaft and gears as outlined in paragraph 152.

The idler gear shaft is retained in the housing by a clip (1) at rear of shaft. The

cluster gear contains two rows of loose needle rollers (28 each row) which use the shaft and gear as inner and outer races. Removal and installation will be facilitated by using a dummy shaft 25 mm (1 inch) in diameter and 55 mm (2-3/16 inch) long to retain loose needle rollers inside the gear during removal and installation. Remove retaining clip and push dummy shaft into the gear from the front displacing the idler shaft rearward. Lift out gear assembly with dummy shaft.

To reinstall, reverse the disassembly procedure. Use petroleum jelly along with the dummy shaft to hold needle rollers in place in gear cluster.

**DIFFERENTIAL AND BEVEL DRIVE GEARS**

Orchard model tractors and all MF250 tractors are equipped with planetary final drive units located in outer end of rear axle housings. On all other models, the rear axle shaft splines directly into the differential side gears. All models may be equipped with a mechanically actuated jaw-type differential lock.

To reassemble differential, reverse the disassembly procedure while noting the following special instructions: If bevel ring gear was removed, use special epoxy bonding kit when reinstalling. Be sure to follow kit instructions and cure epoxy for correct time at specified temperature. Apply Loctite 262 to threads of ring gear

retaining bolts and tighten evenly to 160 N · m (120 ft.-lbs.) torque. Be sure to align differential case scribe marks, and tighten retaining cap screws to 108 N · m (80 ft.-lbs.) torque.

To reinstall differential, reverse the removal procedure. If differential case halves and/or carrier bearings were

**DIFFERENTIAL**

**All Models**

158. **R&R AND OVERHAUL.** The ring gear and differential unit can be removed from differential housing after removing the rear axle housing assembly from left-hand side of tractor as outlined in paragraph 165 or 167.

To disassemble the removed differential unit, first scribe alignment marks on both halves of differential case to ensure correct reassembly. Pull bearing cone (7—Fig. 155) off differential lock coupler cap (8), then remove cap screws retaining coupler cap. Remove coupler cam and separate differential case halves (9 and 16). Differential side gears (11), pinion gears (13) and cross (12) can now be removed.

The main drive bevel ring gear (15) is secured to differential case half with either special bolts and nuts or rivets. Note that ring gear is a press fit on case and may also be epoxy bonded to case if it has been previously serviced.

Inspect all parts for scoring, chipping, wear or other damage and renew if necessary. Pinion gears (13) and cross (12) should be renewed as a set. Backlash between pinion gears and side gears should be 0.08-0.28 mm (0.003-0.011 inch).

Fig. 155—Exploded view of differential and bevel gears for Orchard models and all MF250 models. Other tractors are similar except bearing carrier housings (1 and 19) are not used. Some models use a lockwasher in place of pins (29) to retain adjusting nut (28).

1. Carrier housing (R.H.)
2. "O" ring
3. Spacer shield
4. Bearing cup
5. Differential lock fork
6. Jaw coupler
7. Bearing cone
8. Coupler cap
9. Differential case half
10. Thrust washer
11. Side gear
12. Cross
13. Pinion gear
14. Thrust washer
15. Bevel ring gear
16. Differential case half
17. Bearing cup
18. Bearing cone
19. Carrier housing (L.H.)
20. Snap ring
21. Bearing
22. Bevel pinion gear
23. Bearings
24. Locking pin
25. Retainer housing
26. Drive gear hub
27. Spacer
28. Adjusting nut
29. Locking pins
30. Pto drive gear
31. Snap ring

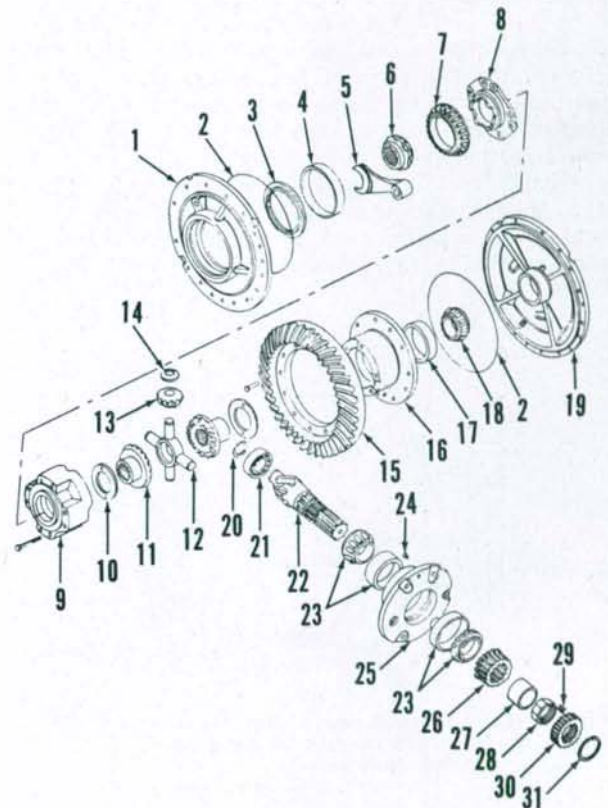

renewed, bearing preload should be checked and adjusted as outlined in paragraph 159.

**159. CARRIER BEARING PRELOAD.** The differential carrier bearing preload is adjusted by installing correct thickness spacer shield (3—Fig. 155), or shim depending on differential type, under right-hand carrier bearing cup (4). The recommended method of checking the preload adjustment is by use of Massey-Ferguson special tool (MFN 245UK). If tool is not available, an alternate procedure (although not as accurate) can be used as follows:

This adjustment procedure should be performed with bevel drive pinion gear (22) removed to prevent interference with movement of differential. Install differential assembly and left-hand axle housing, or carrier bearing housing (19), depending on differential type. Install a 1.27 mm (0.050 inch) spacer shield, or several shims, and bearing cup into right-hand axle housing or carrier housing (1).

**NOTE: A spacer shield thickness change is likely using this procedure. When shield is removed it is usually distorted beyond reuse.**

Position axle housing or carrier housing (without gasket or "O" ring) onto differential housing and install three or four equally spaced retaining cap screws. Tighten cap screws evenly until end play of differential is just removed. Rotate differential several turns to make certain that bearings are properly seated. Use a feeler gage to measure gap between axle housing and differential housing at several different locations. Preload will be correct when measured gap is 0.43-0.55 mm (0.017-0.022 inch) on models with drum brake axles, or 0.25-0.38 mm (0.010-0.015 inch) on models with disc brake axles. Remove axle housing or carrier housing and change spacer or shim thickness as necessary.

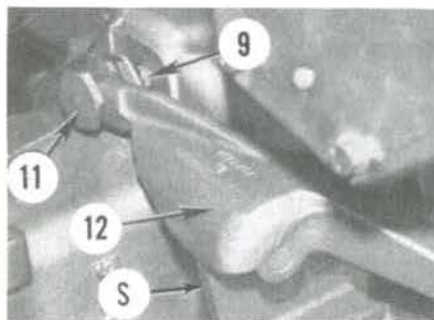

Fig. 156—View of differential lock pedal (12), clevis (11) and locknut (9) used on Orchard models and MF250 models. Refer to text for adjustment.

**DIFFERENTIAL LOCK**

**All Models So Equipped**

**160. OPERATION.** When the differential lock foot pedal is depressed, the axle half of coupler is forced inward to contact the differential case half of the coupler. If slippage is occurring at one wheel, depressing the pedal will cause the coupler dogs to lock the differential case to the right axle. The differential and both drive wheels then rotate together as a unit. As soon as contact is made by the coupler dogs, the pressure will keep the differential lock engaged and foot pedal may be released. When ground traction on both drive wheels again becomes equal, coupler dog contact pressure will be relieved and the coupler will automatically disengage.

**161. ADJUSTMENT.** On all except Orchard models and MF250 models, differential lock coupler should be fully engaged when pedal (16—Fig. 158) clears tractor step plate by 12 mm (1/2 inch). If adjustment is required, loosen clamp screw (17) and reposition pedal (16) on actuating shaft (11). Retighten clamp screw when adjustment is complete. On

Orchard models and MF250 models, pedal (12—Fig. 156) should be against stop (S) when released. If not against stop, loosen locknut (9) and turn clevis (11) until pedal arm just contacts stop (S). Tighten locknut (9) after adjustment is complete.

**162. REMOVE AND REINSTALL.** To remove the differential lock coupler halves (6 and 8—Fig. 155), first drain transmission and hydraulic reservoir, block up under differential housing and remove right fender and rear tire and wheel assembly. Remove right lower hitch link and disconnect right brake linkage. Support rear axle housing assembly in a hoist and remove retaining stud nuts, then slide right rear axle and housing as a unit away from differential housing.

Remove bearing cone (7) from coupling half (8). Remove the differential case retaining cap screws and lift off the coupling (8). When installing, tighten differential case cap screws to a torque of 108 N·m (80 ft.-lbs.).

To remove axle half of coupler on models without planetary final drive, unbolt rear axle outer bearing retainer from axle housing (1—Fig. 158) and

Fig. 157—Exploded view of differential lock actuating mechanism and associated parts used on models with disc brakes.

1. Coupling half
2. Coupling half
3. Shif. fork
4. "O" ring
5. Actuating shaft
6. Washer
7. Spring
8. Snap ring
9. Locknut
10. Boot
11. Clevis
12. Pedal
13. Pivot pin

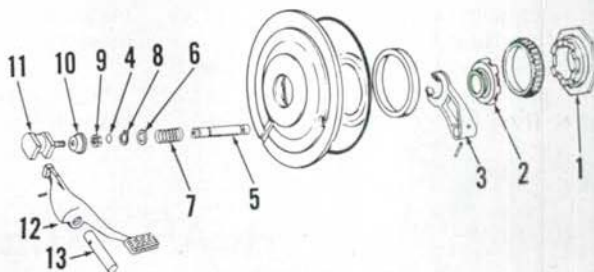
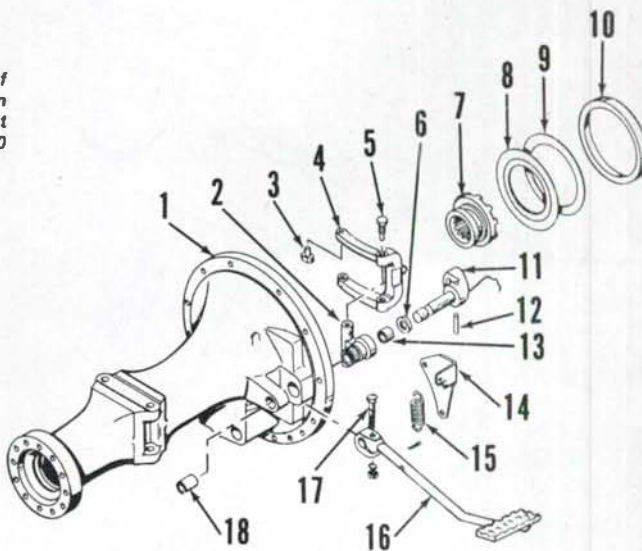

Fig. 158—Exploded view of differential lock mechanism typical of all models except Orchard models and MF250 models.

1. Axle housing (R.H.)
2. Fork bracket
3. Shoe
4. Actuating fork
5. Pivot bolt
6. Oil seal
7. Coupling
8. Spacer shield
9. Shim
10. Bearing cup
11. Actuating cam
12. Pin
13. Bushing
14. Bracket
15. Return spring
16. Pedal
17. Clamp bolt
18. Bushing





withdraw axle from housing; then lift out the coupler (7). Shoes (3) will be free in fork (4) with coupler removed. To service the actuating mechanism, remove the clamp bolt (17) and withdraw actuating shaft (11) from housing and pedal, then lift out the remaining actuating parts.

To remove axle half of coupler (2—Fig. 157) on models with planetary final drive, remove spring pin securing shift fork (3) to actuating shaft (5) and the two countersunk screws securing carrier plate to axle housing, then slide plate, fork and coupler carefully off end of drive axle.

On all models, assemble by reversing the disassembly procedure and adjust as outlined in paragraph 161 after axle housing is reinstalled.

**MAIN DRIVE BEVEL GEARS**

**All Models**

**163. REMOVE AND REINSTALL.** The main drive bevel ring gear (15—Fig. 155) and bevel pinion gear (22) must be renewed as a matched set.

To remove bevel ring gear, first remove differential assembly as outlined in paragraph 158. Ring gear retaining nuts are installed with thread locking compound, and removal will be easier using a slight amount of heat on the nuts. Ring gear is a tight fit and may also be bonded to differential case with epoxy, so it will probably be necessary to press ring gear from differential case.

To remove bevel pinion gear, first remove hydraulic lift cover as outlined in paragraph 207 or 216. Remove axle housings and differential assembly if not previously removed.

On models equipped with independent pto, Multi-Power transmission or auxiliary hydraulics, split the tractor between differential housing and transmission housing. Remove pto side cover, disconnect hydraulic lines, remove pump support pins and remove hydraulic pump assembly and independent pto clutch unit out front of differential housing.

On models not equipped with independent pto, Multi-Power transmission or auxiliary hydraulics, it is not necessary to split the tractor to remove pinion shaft. Remove the coupler tube and pinion drive shaft. Remove side cover from left-hand side of housing and move pto driven gear forward on pto shaft splines. Remove ground speed pto drive gear (30—Fig. 155) from pinion shaft.

On all models, remove cap screws attaching retainer (25) to housing, then thread two of the cap screws into the tapped holes in retainer. Tighten the two cap screws evenly to force retainer with pinion as an assembly from housing bore.

**NOTE:** Check and adjust differential carrier bearing preload, if necessary, before reinstalling bevel pinion gear. Refer to paragraph 159.

When reinstalling bevel pinion gear, make certain that the locating pin (24)

is aligned before pressing retainer into place. Tighten retainer cap screws to 108 N · m (80 ft.-lbs.) torque. Complete installation by reversing the removal procedure.

**164. OVERHAUL.** To disassemble bevel pinion gear, proceed as follows: If bearing adjusting nut (28—Fig. 155) is retained by a tab washer, unlock tabs and remove the nut. If bearing adjusting nut is retained by locking pins (29), it will be necessary to split the nut using a hammer and chisel to remove nut from the shaft. Be careful to avoid damaging threads of pinion when splitting the nut. On all models, bump the pinion shaft out of retainer after nut is removed.

Examine all parts for wear or other damage and renew as necessary. Bearings (23) and retainer (25) are serviced as an assembly.

When reassembling pinion gear, tighten nut (28) to obtain pinion rolling torque of 2.25 N · m (20 in.-lbs.) to provide correct bearing preload. Secure nut by bending tabs of lockwasher or by driving locking pins down both sides of one of the pinion splines. Be sure pins are flush with end of adjusting nut.

When installing the ring gear, make certain that mating surfaces of ring gear and differential case are thoroughly clean and free from nicks or burrs. Apply special epoxy to both mating surfaces and cure for specified time following kit instructions. Apply Loctite 262 to threads of retaining nuts and tighten to 108 N · m (80 ft.-lbs.) torque.

**REAR AXLE AND FINAL DRIVE**

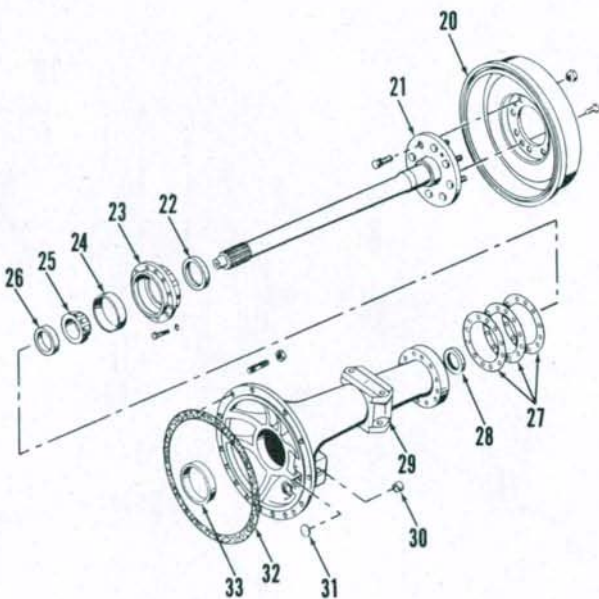

Fig. 159—Exploded view of rear axle and associated parts typical of all tractors except Orchard models and MF250 models.

- 20. Brake drum
- 21. Axle shaft
- 22. Oil seal (outer)
- 23. Retainer
- 24. Bearing cup
- 25. Bearing cone
- 26. Retaining collar
- 27. Shims
- 28. Oil seal (inner)
- 29. Axle housing (L.H.)
- 30. Bushing
- 31. Plug
- 32. Gasket
- 33. Bearing cup

Orchard models and MF250 models are equipped with a planetary type final drive unit located in outer end of rear axle housing. All other models are equipped with a straight drive axle that splines directly into the differential side gears. Refer to the appropriate following paragraphs for removal and overhaul procedures.

**All Models Without Planetary Final Drive**

**165. REMOVE AND REINSTALL.** The axle shafts (21—Fig. 159) can be removed from tractor without removing axle housings (29) if desired. Raise and support rear of tractor, then remove rear wheel and tire. Remove brake drum retaining screws and pull drum from axle flange. Remove cap screws attaching retainer (23) to axle housing, then

withdraw axle shaft with bearing assembly and shims from housing.

To reinstall, reverse the removal procedure while noting the following special instructions: Install inner oil seal (28) into axle housing with lip facing inward. Grease lip of seal before inserting axle shaft. Use a dial indicator to check end play between the axles. Be sure axle on opposite side is moved fully outward when checking end play. Change thickness of shims (27) as necessary to obtain end play of 0.05-0.20 mm (0.002-0.008 inch). Note that end play is controlled by total thickness of shims installed between both axle housings and retainers, and varying the thickness of either shim pack will affect adjustment of both axles. Tighten retainer cap screws to 75 N·m (55 ft.-lbs.) torque.

To remove axle shaft and housing (29) as a unit, first drain oil from differential housing. Raise and support rear of tractor, then remove rear wheel and fender. Disconnect brake linkage and hitch lift link and lower link. Support axle housing with a hoist, remove attaching stud nuts and slide axle housing assembly from tractor.

**NOTE:** When left-hand axle housing is removed, be careful that differential assembly is not accidentally pulled out with the axle housing.

To reinstall axle housing assembly, reverse the removal procedure. Tighten housing stud nuts to 115 N·m (85 ft.-lbs.) torque. Tighten wheel stud nuts to a torque of 230 N·m (170 ft.-lbs.).

**166. OVERHAUL.** The axle retainer (23—Fig. 159) and bearing cone (25) are retained on axle shaft by a shrink-fit steel collar (26). To renew axle shaft, bearing, retainer or outer oil seal (22), first drill the collar, then split collar using a hammer and chisel. Pull the retainer, bearing and collar from axle shaft using a suitable puller or press.

Install a new seal (22) into retainer with lip of seal facing the bearing cup (24). Grease lip of seal before installing retainer over axle shaft. Seat bearing cone against shoulder of shaft. Heat a new retaining collar to approximately 400°C (750°F), then quickly install and seat the collar against the bearing cone.

Renew inner oil seal (28) in axle housing before reinstalling axle shaft. Be sure lip of seal faces inward.

**All Models With Planetary Final Drive**

**167. R&R AXLE HOUSING.** To remove either axle housing with planetary assembly as a unit, first drain oil from differential housing. Support

rear of tractor and remove rear wheel and tire and the fender. Disconnect brake linkage and hitch lift link and lower link from axle housing. Support axle housing with a hoist or floor jack, remove attaching stud nuts and separate final drive assembly from differential housing.

To reinstall, reverse the removal procedure. Tighten housing stud nuts to 115 N·m (85 ft.-lbs.) torque. Tighten wheel stud nuts to 270 N·m (200 ft.-lbs.) torque on tractors equipped with 5/8 inch diameter studs, or to 325 N·m (240 ft.-lbs.) on tractors equipped with 11/16 inch diameter studs.

**168. R&R PLANETARY ASSEMBLY.** To remove planetary assembly, suitably support rear of tractor and drain oil from final drive planetary housing. Remove the wheel and tire and the fender. Securely apply parking brake to hold brake discs in alignment in case axle shaft is pulled outward. Scribe a mark across outer housing (21—Fig. 160), ring gear (8) and axle housing (1) to ensure correct alignment when reassembling. Remove retaining stud nuts, then withdraw outer housing and ring gear assembly.

To reinstall, reverse the removal procedure making certain that scribe marks are correctly aligned. Tighten attaching nuts to a torque of 75 N·m (55 ft.-lbs.). Refill drive housing with Massey-Ferguson Permatran III Oil, or equivalent. Capacity is approximately 1.0 L (1.1 U.S. quart).

**169. OVERHAUL PLANETARY.** To disassemble the planetary unit, first drive roll pins (11—Fig. 160) inward into carrier. Thread a 3/8 inch cap screw into end of planet gear shaft (15) and pull shaft from carrier. Remove planet gears

(13) being careful not to lose the loose needle rollers. There are two rows of 29 rollers in each gear. Withdraw sun gear through large opening in carrier. Using a suitable puller, separate the carrier (10) from drive cover (21). Remove half rings (18) from wheel axle (24), then press axle out of drive cover. Remove axle shaft (5), inner bearing cup (3), shims (6) and oil seal (2), if so equipped, from axle housing.

**Note** that axle oil seal (2) has been eliminated on late production tractors to provide a common reservoir for planetary and differential housings. When servicing early production tractors equipped with the seal, do not install a new seal when reassembling. On all models, planetary housings must still be refilled with recommended oil, approximately 1.0 L (1.1 U.S. quart) each planetary, to provide initial supply of lubricant.

To reassemble, install a new oil seal (22) into drive cover (21) until outer face of seal is 2 mm (0.080 inch) above surface of cover. Lubricate seal lip, then insert wheel axle (24) into cover. Press bearing cone (19) onto axle until rollers are seated in bearing cup (20). Install thickest pair of split rings (18) that will fit into wheel axle groove.

Assemble sun gear and planet gears into carrier using new roll pins to retain planet gear shafts. Be sure to account for all the planet gear needle rollers. Press carrier assembly onto wheel axle until it is seated against the split rings.

Complete reassembly by reversing the disassembly procedure. Check planet carrier bearing preload as outlined in paragraph 170.

**170. CARRIER BEARING PRELOAD ADJUSTMENT.** Planet carrier bearing preload of 0.15-0.40 mm

Fig. 160—Exploded view of planetary final drive used on Orchard models and MF250 models. Axle oil seal (2) is not used on late production tractors, and should be removed and discarded when servicing early production tractors.

- 1. Axle housing
- 2. Oil seal
- 3. Bearing cup
- 4. Bearing cone
- 5. Axle shaft
- 6. Shim
- 7. Gasket
- 8. Ring gear
- 9. Bushing
- 10. Planet carrier
- 11. Roll pin
- 12. Thrust washers
- 13. Planet pinion
- 14. Needle rollers
- 15. Pinion shaft
- 16. Sun gear
- 17. Spacer
- 18. Snap ring
- 19. Bearing cone
- 20. Bearing cup
- 21. Drive cover
- 22. Oil seal
- 23. Dust shield
- 24. Wheel axle

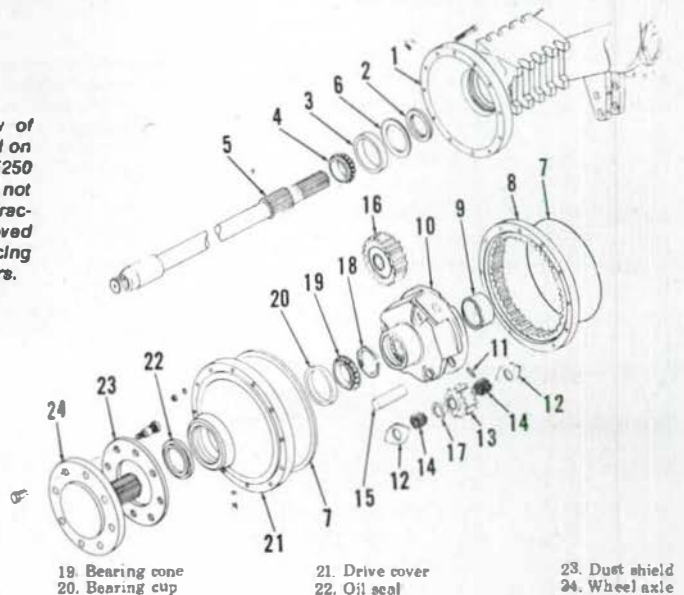

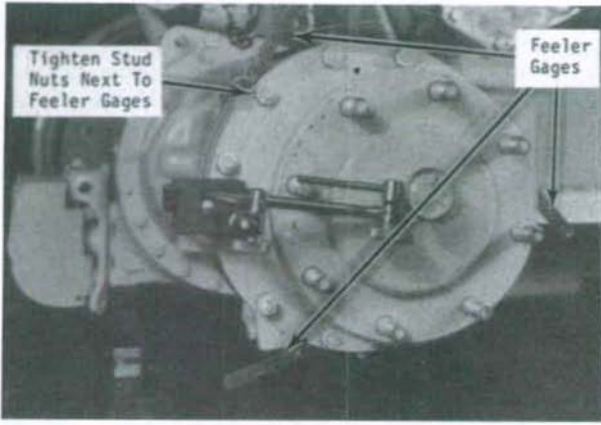

Fig. 161—Measure wheel axle end play with a dial indicator as shown to check and adjust planetary carrier bearing preload. Refer to text.

(0.006-0.016 inch) is adjusted by means of shims (6—Fig. 160) installed between inner bearing cup (3) and axle housing (1).

To check and/or adjust bearing preload, first drain oil from differential housing and final drive planetary housing. Loosen stud nuts securing planetary housing to axle housing, then insert three 0.76 mm (0.030 inch) feeler gages between planetary ring gear and axle housing as shown in Fig. 161. Tighten nuts next to feeler gages to 75 N · m (55 ft.-lbs.) torque, then measure wheel axle end play with a dial indicator. If measured end play is within range of 0.36-0.61 mm (0.014-0.024 inch), preload is correct and no change in shim thickness is required. If end play is less than 0.36 mm (0.014 inch), preload is excessive and shim pack thickness should be reduced. If end play exceeds 0.61 mm (0.024 inch), preload is insufficient and shim pack thickness should be increased.

## BRAKES

Orchard models and Model MF250, which have planetary type final drive units in outer ends of rear axle housing, are equipped with disc type brakes. The disc brakes operate in a dry compartment within the axle housings on some models, while other models are equipped with wet type brakes.

All other models are equipped with internal expanding shoe type brakes located at the axle wheel ends.

### SHOE-TYPE BRAKES

#### All Models So Equipped

171. **ADJUSTMENT:** Raise and block rear of tractor so rear wheels are off the ground. Remove adjusting cover (11—Fig. 162) and, using a screwdriver or adjusting tool, turn star wheels (3) until

shoes contact brake drum. Back off star wheels an equal amount until drums are free and brake pedal free travel is 25 mm (1 inch) measured at pedal pad.

Latch brake pedals together, then check for uneven brake application. If necessary, loosen brake adjuster on side that is tight until brakes apply evenly.

172. **OVERHAUL.** The brake drum (1—Fig. 162) can be removed after remov-

ing the rear wheel and the two drum retaining screws. Remove shoe retaining pins and springs (8), anchor springs (2) and brace (4). Lift off shoes (6) with adjuster (3) and spring (7).

To remove brake camshaft (9), disconnect brake rod and loosen set screw in brake lever (14). Withdraw camshaft from brake lever and backing plate (10).

To reassemble, reverse the disassembly procedure. Adjust brake rod length so camshaft contacts, but does not move brake shoes with pedal fully up against its stop. Adjust brake shoes as outlined in paragraph 171.

### DISC-TYPE BRAKES

#### All Models So Equipped

173. **ADJUSTMENT.** To adjust disc brakes, first make sure both brake rods (10—Fig. 163) are adjusted to equal lengths. Raise and support rear of tractor so rear wheels are off the ground. Turn brake adjusting nut (9) at each brake lever (7) until brake pedal free play is 63.5 mm (2-1/2 inches) measured at pedal pad.

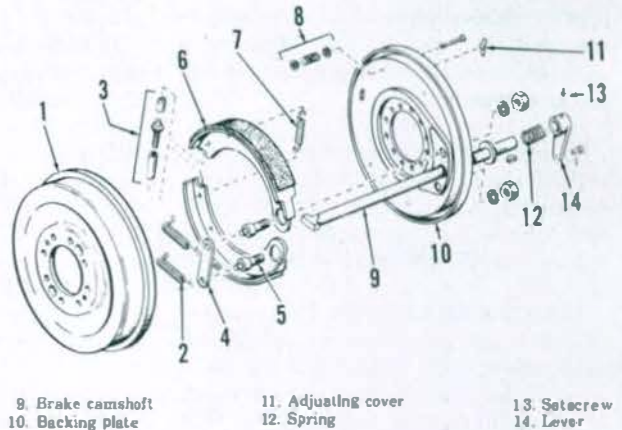
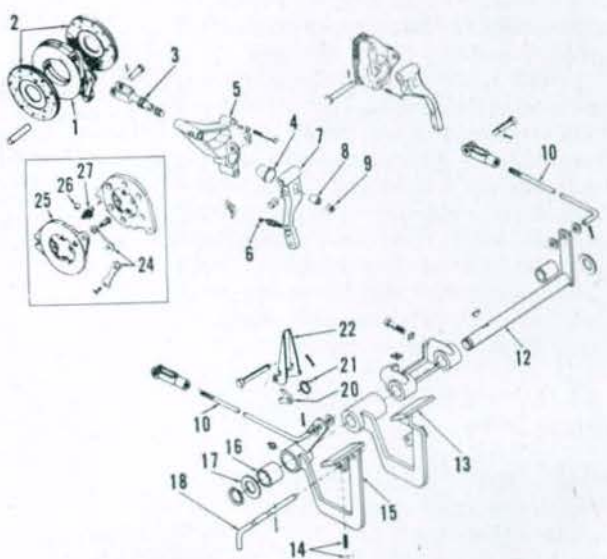

Fig. 162—Exploded view of shoe and drum type brakes used on all models except Orchard models and MF250 models. Pedals, cross shaft and operating rods are similar to type shown in Fig. 163.

1. Brake drum
2. Anchor springs (blue)
3. Adjuster
4. Anchor
5. Anchor pins
6. Brake shoes
7. Adjuster spring (orange)
8. Hold-down unit

9. Brake camshaft
10. Backing plate
11. Adjusting cover
12. Spring
13. Set screw
14. Lever

Fig. 163—Exploded view of dry type disc brakes used on some Orchard models. Later Orchard models and all MF250 models are equipped with wet type brakes as shown in Fig. 164.



1. Actuating disc
2. Lined discs
3. Brake rod
4. Seal
5. Support
6. Spring
7. Brake lever
8. Adjusting block
9. Adjusting nut
10. Brake rod
11. Cross shaft
12. Brake pedal
13. Brake pedal
14. Detent
15. Brake pedal
16. Bushing
17. Thrust washer
18. Interlock lever
19. Pawl
20. Pawl
21. Spring
22. Latch
23. Link
24. Link
25. Actuating disc
26. Steel balls
27. Return springs

Latch brake pedals together and road test to check for uneven brake application. If brakes pull to one side, equalize braking action by turning brake lever adjusting nut counterclockwise on side that pulls.

**174. OVERHAUL.** To remove disc brake assemblies, first remove complete axle housing assembly as outlined in paragraph 167. Remove brake actuator assembly from left-hand side, and remove actuator assembly with differential lock mechanism from right-hand side. Remove retaining screws and withdraw differential carrier plate. Remove brake components from axle housing keeping parts in order to ensure correct reassembly.

If brake parts and compartment are coated with oil on models equipped with dry brakes, make certain that necessary oil seals are renewed before reassembling brakes. Unhook springs (27—Fig. 163 or 164) and examine actuator unit (25) and balls (26) for wear or pitting. Groove depth in wet type friction discs (2—Fig. 164) is approximately 0.3 mm (0.012 inch) when new. Friction discs should be renewed when worn to the point that grooves begin to disappear. The intermediate plates (28) should be renewed whenever friction discs are renewed.

To reassemble brakes, reverse the removal procedure while noting the following special instructions: On wet type brakes, dip friction discs, intermediate plates and actuator unit in clean transmission oil prior to reassembly. Two friction discs and one separator plate are installed on planetary side of brake actuator unit and remaining discs and plates are installed on differential side of actuator. Be sure that lip of rubber boot (4) is seated correctly in groove of actuator rod (3) and that garter spring is in proper position.

Adjust brakes as outlined in paragraph 173.

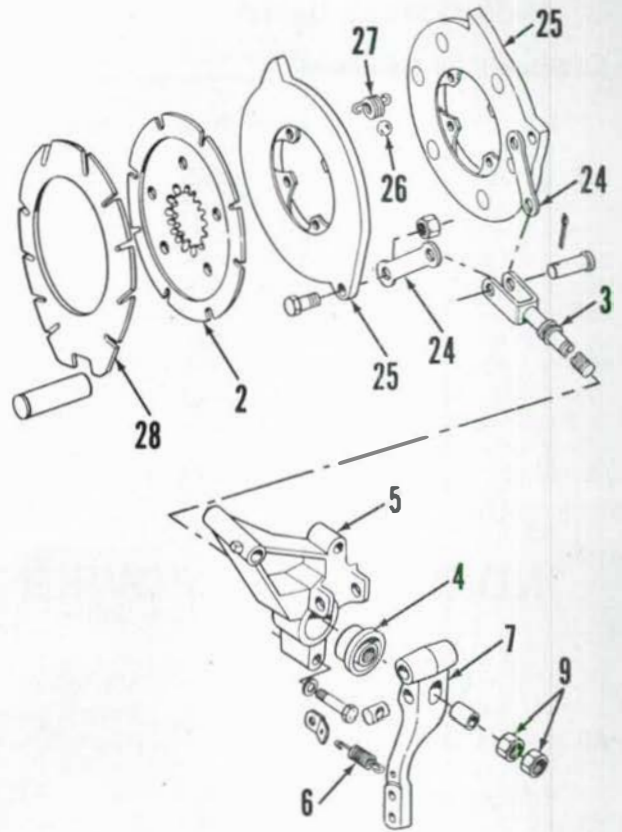

Fig. 164—Exploded view of wet disc brakes used on some Orchard models and all MF250 models. Except for intermediate plate (28), refer to Fig. 163 for legend.

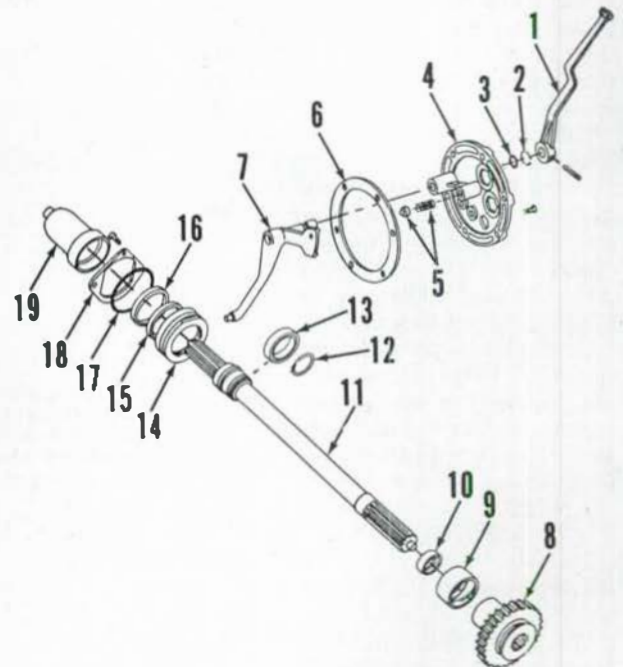

Fig. 165—Exploded view of typical pto output shaft and associated parts used on models equipped with live pto. On some models, parts will vary slightly from those shown.

1. Shift lever
2. Snap ring
3. "O" ring
4. Shift cover
5. Detent plunger & spring
6. Gasket
7. Shift fork
8. Ground speed gear & shift coupling
9. Bushing
10. Needle bearing
11. Output shaft
12. Snap ring
13. Bearing
14. Seal retainer
15. Metal shield
16. Metal shield
17. "O" ring
18. Retainer plate
19. Shaft cover

## POWER TAKE-OFF (LIVE)

### OUTPUT SHAFT

#### All Models So Equipped

**175.** To remove pto output shaft (11—Fig. 165), first drain oil from differential housing. Remove pto shield and retainer plate (18) from rear of housing. Withdraw shaft, rear bearing (13) and

seal housing (14) as an assembly. Oil seal (16) and rear bearing (13) can be renewed at this time.

Output shaft front needle bearing (10) can be renewed after first removing differential assembly as outlined in paragraph 158. Remove bearing rearward, then use appropriate size step

plate and driver to install new bearing flush to slightly below rear face of housing bore. Refer to paragraph 176 for renewal of ground speed drive gear (8) and bushing (9).

To reinstall output shaft, reverse the removal procedure. Be sure to lubricate oil seal and "O" ring during assembly.

**GROUND SPEED GEARS**

**All Models So Equipped**

176. To remove ground speed drive gear, driven gear (8—Fig. 165) and bushing (9), first remove pto output shaft as outlined in paragraph 175. Remove hydraulic lift cover as outlined in paragraph 207 or 206. Remove hydraulic pump as outlined in paragraph 223 or 225. Remove retaining snap ring (31—Fig. 155) and slide drive gear (30) off bevel pinion shaft. Remove pto shift cover (4—Fig. 165), then slide driven gear (8) forward out of bushing (9).

To renew driven gear bushing (9), remove differential assembly as outlined

in paragraph 158. Drive bushing forward from housing bore. Install new bushing so front face of bushing is flush with inner end of chamfer in housing bore.

To reinstall gears, reverse the removal procedure.

**PTO MAIN DRIVE GEARS**

**All Models So Equipped**

177. The pto main drive gears and clutch are included in the transmission drive train. Refer to appropriate transmission and clutch sections for removal and overhaul.

**INDEPENDENT POWER TAKE-OFF**

**OPERATION**

**All Models So Equipped**

178. Some tractors may be equipped with an independent pto which is driven by a flywheel mounted "Split Torque" clutch and controlled by a hydraulically actuated multiple disc clutch contained in differential housing. The pto front drive shaft is splined into hub of the "Split Torque" clutch cover and turns continuously when engine is running.

The pto control lever is mounted on left-hand side of cover of differential housing. Moving lever forward disengages the hydraulically actuated multiple disc clutch and engages the pto brake. Moving lever rearward releases the hydraulic brake and engages the multiple disc pto clutch.

Hydraulic pressure to actuate the pto clutch and brake is produced by the auxiliary gear type pump which also provides power for the Multi-Power clutch and/or auxiliary hydraulic system if tractor is so equipped.

**OUTPUT SHAFT**

**All Models So Equipped**

179. REMOVE AND REINSTALL. To remove output shaft (6—Fig. 166), first drain oil from differential housing. Remove shield and retainer plate (17) from rear of housing. Withdraw shaft, rear bearing and seal assembly rearward from housing.

Inspect all parts and renew as necessary. Renewal of front needle bearing (7) requires splitting tractor and removing pto clutch assembly as outlined in paragraph 180.

differential housing.

Reinstall by reversing the removal procedure.

181. OVERHAUL. To disassemble the removed clutch and valve unit, proceed as follows: Remove snap ring (16—Fig. 167) and thrust washer (15), then withdraw control valve housing (14) with brake cylinder (20) from clutch housing (11). Brake disc (12) is retained to clutch housing by two pins (10). Unbolt and remove brake cylinder (20), piston (19) and wear plate (17) from valve housing.

Remove snap ring (1), retainer plate (2), friction plates (3), wave springs (4) and drive plates (5). Lift out drive hub (6). Remove piston (7) and seal rings (8 and 9).

Withdraw control valve spool assembly (Fig. 168) from housing (8). Unseat internal snap ring (5) to separate valve spool (6) from plunger (2). Note that spacer ball (4) is available in different diameters and is used to establish collapsed length of control valve assembly. Recommended valve length is 102.36-103.12 mm (4.030-4.060 inches) measured as shown at (L—Fig. 169).

Renew clutch plates and discs if they are excessively worn, distorted or show signs of overheating. Measure free height of wave springs with springs laying on a flat surface. All springs should be the same height within 0.5 mm (0.020 inch).

**NOTE:** New friction discs should be soaked in clean transmission/hydraulic oil for 30 minutes before installation.

Fig. 166—Exploded view of typical pto output shaft and associated parts used on models equipped with independent pto.

1. Shift lever
2. Shift cover
3. Detent plunger & spring
4. Shift arm
6. "O" ring
6. Output shaft
7. Bearing
8. Control valve spool
9. Sleeve
10. Clutch assy.
11. Snap ring
12. Bearing
13. Seal retainer
14. Metal shield
15. Oil seal
16. "O" ring
17. Retainer plate
18. Shaft cover

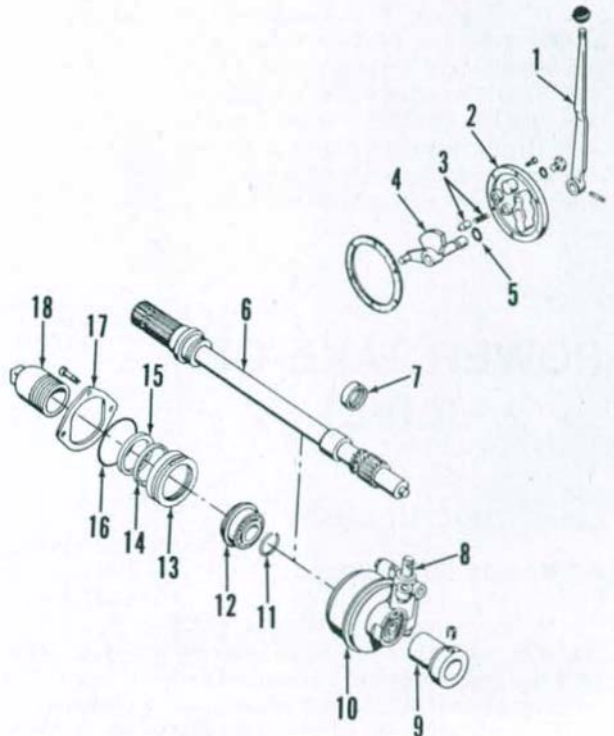

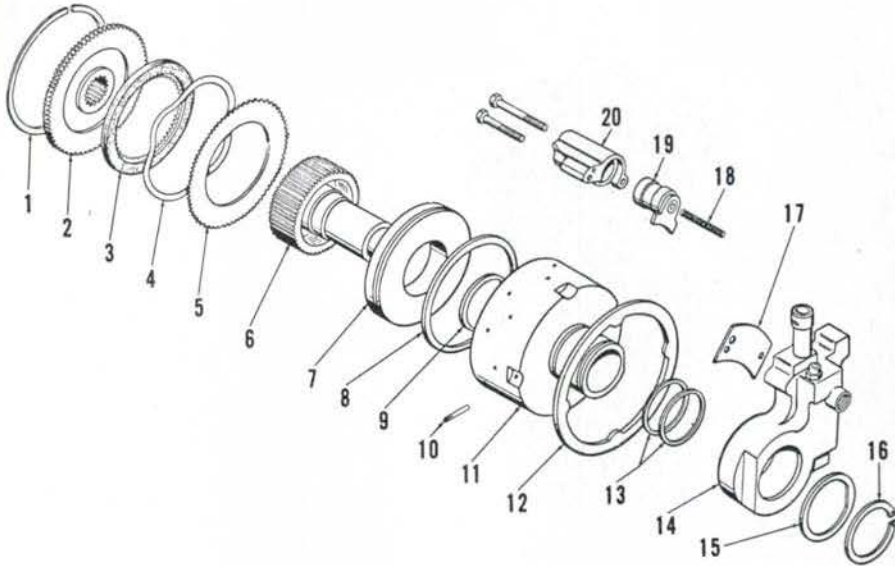

Fig. 167—Exploded view of independent pto multiple disc clutch and hydraulic brake unit.

- |                   |                |                    |                         |
|-------------------|----------------|--------------------|-------------------------|
| 1. Snap ring      | 6. Drive hub   | 11. Clutch housing | 16. Snap ring           |
| 2. Retainer plate | 7. Piston      | 12. Brake disc     | 17. Brake wear plate    |
| 3. Friction disc  | 8. Piston ring | 13. Seal rings     | 18. Return spring       |
| 4. Wave springs   | 9. Piston ring | 14. Valve housing  | 19. Piston & shoe assy. |
| 5. Drive plates   | 10. Pin        | 15. Thrust washer  | 20. Brake cylinder      |

To reassemble, install piston with new seal rings into housing. As an aid in installing piston, three or four pieces of 4 mm (3/16 inch) diameter rod (Fig. 170) can be inserted into clutch housing to serve as alignment guides for piston. Place drive hub in housing, then alternately install drive plates, wave springs and friction discs making sure that a drive plate is installed first against piston. Push down on clutch pack to compress wave springs, then insert two small diameter pins into clutch housing oil holes as shown in Fig. 171 to hold clutch pack partially compressed. Install retaining plate and snap ring, then remove the assembly pins from clutch housing oil holes.

Install seal rings (13—Fig. 167) on clutch housing and lubricate with hydraulic oil. Install valve housing (14), thrust washer (15) and snap ring (16). Assemble brake piston (19), spring (18) and cylinder (20). Position wear plate (17) under brake disc, then install brake cylinder assembly using a new “O” ring.

**182. PRESSURE TESTING.** Power for the pto clutch and brake is supplied by the gear type auxiliary pump which also supplies the Multi-Power transmission clutch and/or auxiliary hydraulic system if so equipped. Refer to paragraph 232 for auxiliary pump service information.

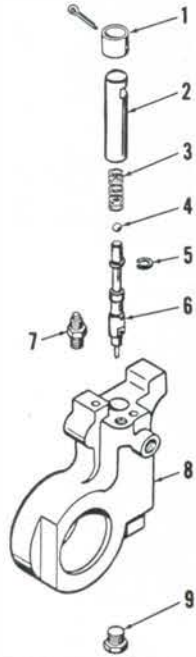

Fig. 168—Exploded view of independent pto control valve assembly.

- |                 |                |
|-----------------|----------------|
| 1. Retainer cap | 6. Valve spool |
| 2. Plunger      | 7. Connector   |
| 3. Spring       | 8. Housing     |
| 4. Spacer ball  | 9. Plug        |
| 5. Snap ring    |                |

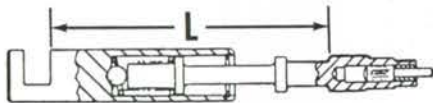

Fig. 169—Collapsed length (L) of pto control valve should be 102.36-103.12 mm (4.030-4.060 inches) measured as shown. Length is adjusted by installing a different diameter spacer ball.

Fig. 170—When installing pto clutch piston, several 4 mm (3/16 inch) diameter rods can be inserted into clutch housing as shown to help align piston in housing.

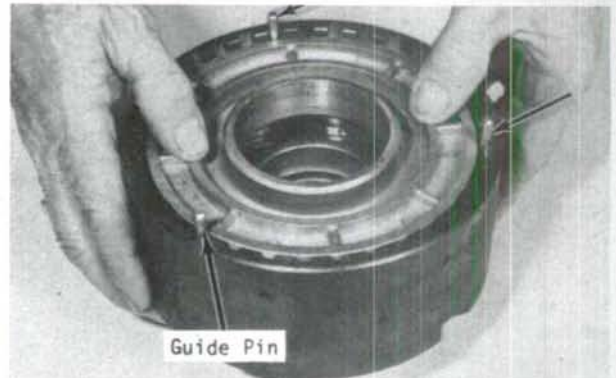
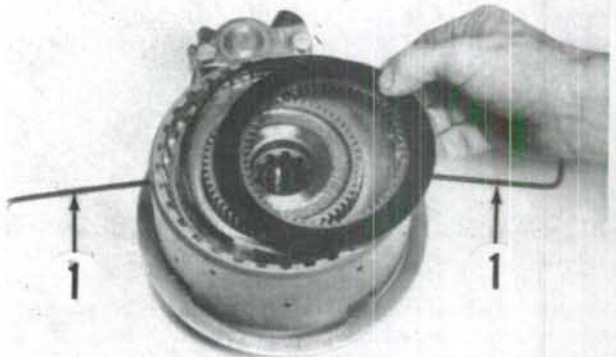

Fig. 171—Compress clutch pack, then insert two small diameter pins (1) into oil holes in housing to hold plates in place while installing retaining plate and snap ring.



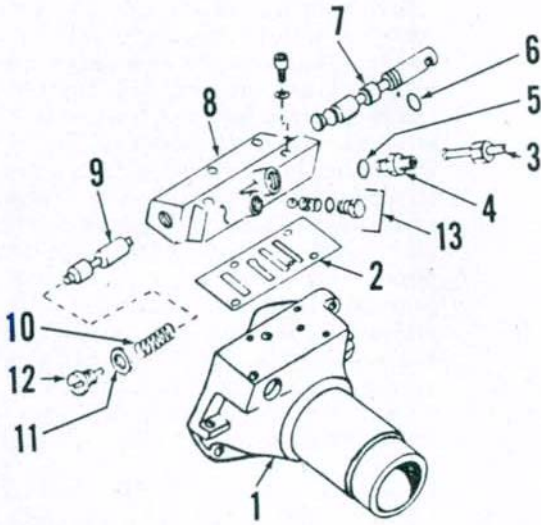

Fig. 172—Exploded view of pto clutch pressure regulating valve and associated parts. Multi-Power shift control valve (if so equipped) is also located in the valve body.

1. Input shaft retainer
2. Gasket
3. Pressure line
4. Fitting
5. "O" ring
6. "O" ring
7. Multi-Power shift valve
8. Valve body
9. Pressure regulating valve
10. Spring
11. Gasket
12. Plug
13. Detent assy.

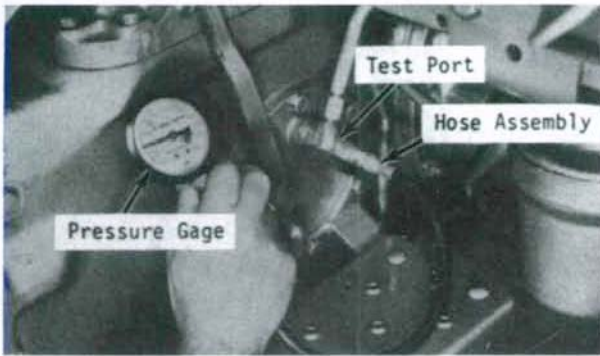

Fig. 173—Connect pressure gage to test port in pto shift cover as shown to check regulating valve pressure.

To check pto clutch pressure, first operate tractor until hydraulic oil temperature is 50°-60°C (120°-140°F). Remove pressure test port plug from pto shift cover and install a 4000 kPa (600 psi) pressure gage in test port as shown in Fig. 173. Start engine and run at 1800 rpm, then move control lever to engaged (rear) position. Pressure gage reading

should be 1900-2240 kPa (275-325 psi). Move pto shift lever to disengaged position. Pressure should drop to zero and pto shaft should stop rotating in about five seconds.

If pressure or pto operation is not as specified, remove and overhaul pto control valve unit as outlined in paragraph 181.

## HYDRAULIC SYSTEM

### GENERAL

#### All Models

184. Two different types of hydraulic systems have been used, and identification of the type of system must be established before proceeding with adjustments or repairs. One type of system has a dashpot (1—Fig. 174) attached to the lift cover, and lift cover has casting number 1861 320 M1. The other type of system does not use a dashpot (refer to Fig. 174A). Either system may or may not have provisions for pressure control.

On all models, hydraulic lift system consists of a pto driven piston type pump, which is mounted within the differential housing beneath the lift cover, and a

single acting hydraulic cylinder which actuates the rockshaft and lift arms. A gear type auxiliary pump is optionally added to supply operating fluid to Multi-Power clutches, pto clutches and/or auxiliary hydraulic cylinder applications. Auxiliary pump is located directly above lift system pump, and is driven by a gear train mounted to front of pumps.

### RESERVOIR AND FILTER

#### All Models

185. The transmission/differential lubricant is the operating fluid for the hydraulic system. Recommended fluid is Massey-Ferguson Permatran III Oil.

Manufacturer recommends renewing hydraulic oil after every 500 hours of operation, or annually, whichever comes first.

The hydraulic pump strainer/filter, located in bottom of differential housing (Fig. 175), should be removed and cleaned after every 500 hours of operation. Note that oil must be drained from housing before removing filter. Filter element can be cleaned using solvent and compressed air. Renew filter element if damaged or if it cannot be thoroughly cleaned.

Some models are also equipped with an auxiliary hydraulic filter located on left-hand side of the differential housing. Auxiliary filter element should be renewed after every 500 hours of operation.

### TROUBLE-SHOOTING

#### All Models

186. The following are symptoms which may occur during operation of the hydraulic lift system and their possible causes. Use this information in conjunction with the Checks and Adjustments information to isolate the cause of the problem before proceeding with component disassembly.

1. Hitch will not raise. Could be caused by:
  - a. Leak in system. Remove response control side cover and check for internal leakage.
  - b. Damaged, binding or misadjusted control valve linkage.
  - c. Misadjusted or faulty servo valve (pressure control units), or faulty safety relief valve (nonpressure control units).
  - d. Faulty hitch lift pump.
2. Lift links raise unevenly or jerky. Could be caused by:
  - a. Valve sticking in pump valve chamber.
3. Lift links will not raise to full height. Could be caused by:
  - a. Transport stop misadjusted.
  - b. Control valve misadjusted.
  - c. Control linkage misadjusted.
4. Lift links will not lower. Could be caused by:
  - a. Control valve sticking.
  - b. Control valve misadjusted.
  - c. Lift arms binding.
5. Hitch lowers too fast with response control at "SLOW" position. Could be caused by:
  - a. Response control misadjusted.
  - b. Control linkage binding or damaged.
  - c. Faulty dashpot (if so equipped).
6. Erratic action when operating in draft control. Could be caused by:

- a. End play in master control spring.
  - b. Control linkage binding or damaged.
7. Lift links creep down. Could be caused by:
- a. Internal leakage in cylinder, control valve or valve chambers.

**SYSTEM CHECKS**

**All Models**

187. Before beginning system checks, be sure oil level is at full mark on dipstick (5—Fig. 176), and test system only after oil has reached operating temperature of approximately 50°C (120°F). Connect a 35000 kPa (5000 psi) pressure gage (1) at test port (3) in lift cover. Move the response control lever (4) to “FAST” and the inner quadrant lever (6) to “TRANSPORT.” If system is pressure control type, make sure that transport stop (7) is fully rearward directly beneath “PRESSURE” range of inner quadrant. If system is nonpressure type, check that center of rear bolt holding transport stop (7—Fig. 177) is 11 mm (7/16 inch) from rear of quadrant stop. On all models, check to be sure lever friction springs are compressed to 20.6 mm (13/16 inch). This amount of compression should permit levers to slide freely, but should hold position when released.

*Fig. 175—View showing location of transmission housing and differential housing drain plugs (1) and pump filter cover (2).*

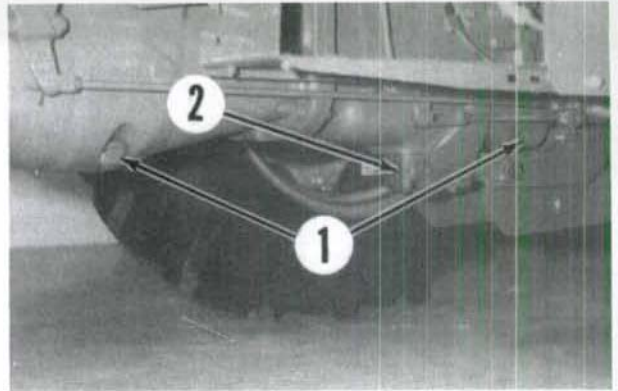

*Fig. 176—View of pressure control, 3-point lift system showing location of components used in testing. Connect 35000 kPa (5000 psi) pressure gage (1) to port (3).*

- 1. Pressure gage
- 2. Hose
- 3. Test port
- 4. Response control lever
- 5. Oil level dipstick
- 6. Inner quadrant lever
- 7. Transport stop
- 8. Draft control lever

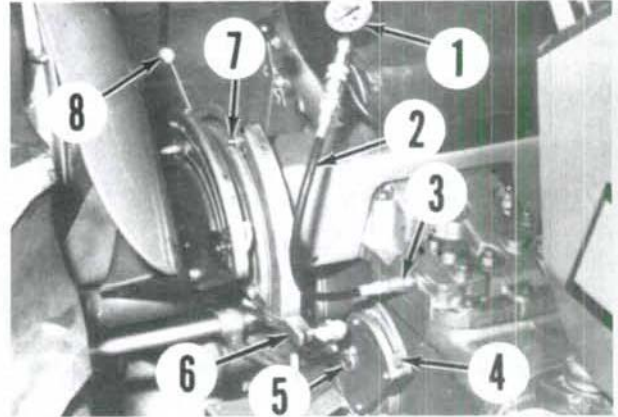

188. **TRANSPORT STOP.** To check transport stop adjustment, proceed as follows: Run engine at 1000 rpm and

move draft control lever to full “UP” position.

If pressure control type, move inner quadrant lever (6—Fig. 178) to “CONSTANT PUMPING” range forward of the transport stop (7). Scribe a line (L) across lift arm hub and lift cover casting. Move inner lever forward in “POSITION” control range to lower the lift links, then move lever back against the transport stop. Measure the distance that scribe lines are separated.

If nonpressure control style, move inner quadrant lever (6— Fig. 177) fully “UP” in quadrant past the transport

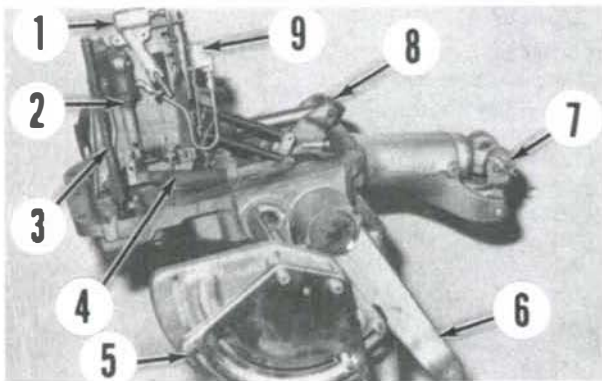

*Fig. 174—View of hydraulic lift cover with mounted dashpot (1) and pressure control system.*

- 1. Dashpot
- 2. Pressure control valve
- 3. Standpipe
- 4. Pressure control lever
- 5. Control quadrant
- 6. Lift arms
- 7. Master control spring assy.
- 8. Rockshaft arm
- 9. Diaphragm assy.

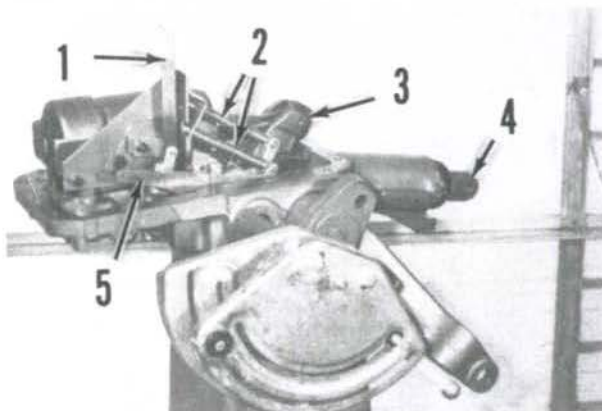

*Fig. 174A—View of hydraulic lift cover without mounted dashpot (pressure control model shown).*

- 1. Vertical lever
- 2. Draft & position control rods
- 3. Rockshaft arm
- 4. Master control spring assy.
- 5. Pressure control lever

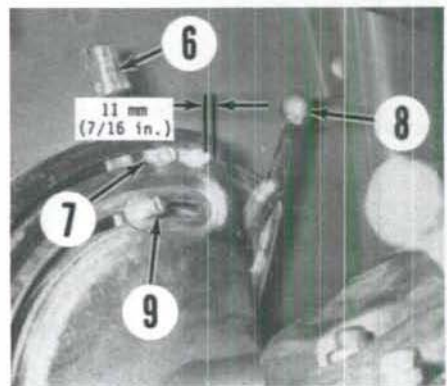

*Fig. 177—View of controls for models without pressure control. Refer to text for tests and adjustments.*

- 6. Inner quadrant lever
- 7. Transport stop
- 8. Draft control lever
- 9. Friction spring



stop (7). Scribe a line across lift arm hub and lift cover casting, then move inner lever back to transport stop. Measure distance that scribed lines are separated.

On all models, distance between scribed lines should be 3.2-3.9 mm (1/8-5/32 inch). If dimension is not correct, adjust transport stop as outlined in paragraph 197 or 204 before proceeding with further tests.

**189. DRAFT CONTROL.** To check draft control, run engine at low idle speed. Move inner quadrant lever (6—Fig. 179) against transport stop (7) and operate draft control lever (8) to raise the lift arms. With draft control lever fully "UP", gage pressure should not be excessive and servo relief (or safety relief) valve should not be opening.

If lift links do not move to full transport or through full range, transport stop may be adjusted incorrectly, lift cover internal linkage may be misadjusted or control valve may be sticking. If servo relief is opening, the transport stop, lift cover linkage or pressure control valve (if so equipped) may be incorrectly adjusted.

Position draft control lever between the sector marks (M) on draft quadrant while leaving inner quadrant lever at "TRANSPORT." The lift links should re-

main at a midposition with draft lever within 6.3 mm (1/4 inch) of either sector mark. If incorrect, refer to paragraph 198 or 205 for adjustment procedure.

**190. POSITION CONTROL.** To check position control, first attach a fully mounted implement to 3-point linkage. Place draft control lever (8—Fig. 176) to full "UP" position and response control lever (4) in "FAST" position. Run engine at low speed and operate inner lever (6) in "POSITION" control range to fully raise and lower lift links several times. It must be possible to fully raise and lower lift links and to position them in any intermediate setting.

If lift links do not raise or lower fully, perform the installed adjustments as outlined in paragraph 195 or 101. If lift links creep down then up again (hunt), internal leakage is indicated in control valve, valve chambers, pump pistons or lift cylinder seal rings.

Move inner quadrant lever to "TRANSPORT." The lift links should raise to transport position without reaching maximum system pressure. If lift links do not reach transport position or if maximum system pressure is obtained, refer to appropriate paragraph 195 or 202 for adjustment procedures.

**191. MASTER CONTROL SPRING SENSITIVITY.** To check sensitivity of control spring, first attach a fully mounted implement to lower links and top link. Place inner quadrant lever (6—Fig. 176) in "TRANSPORT." Operate engine at low rpm and move draft control lever (8) to raise implement to approximately midpoint of lift travel (implement must be clear of ground).

Apply a downward force to rear of implement. System should respond by lowering implement slightly. Apply an upward force to rear of implement. System should raise implement as long as upward force is being applied.

If system does not respond as described, control spring should be adjusted as outlined in paragraph 194 or 201.

**192. RESPONSE CONTROL.** To check operation of response control, first attach a fully mounted implement to 3-point links. Place inner quadrant lever (6—Fig. 176) in "TRANSPORT." Operate engine at low rpm and move draft control lever (8) to full "UP" position. Move response control lever (4) to "SLOW" position, then move draft control lever rapidly to full "DOWN" position.

The implement should hesitate slightly, then lower at a moderate rate of speed. Place response lever in "FAST" position. Repeat lowering test using draft control lever to raise implement, then quickly move control lever to "DOWN" position.

The implement should lower noticeably quicker with response lever in "FAST" position than previous check with lever in "SLOW" position. If response is not as described, adjust as outlined in appropriate paragraph 200 or 206.

**193. PRESSURE CONTROL.** To check operation of pressure control valve (if so equipped), attach an implement or weight to lift links. Run engine at 1000 rpm, move draft control lever (8—Fig. 176) to full "UP" position, move inner quadrant lever (6) to full "HIGH" (constant pumping) in pressure control range of quadrant and observe pressure indicated on gage (1). Pressure should be 17230-17930 kPa (2500-2600 psi).

Move inner lever to full "LOW" position and observe gage reading. Pressure should be 0-500 kPa (0-75 psi). Move inner lever to just raise implement and place a load on hydraulic system. Pressure indicated on gage should not fluctuate more than 700 kPa (100 psi)

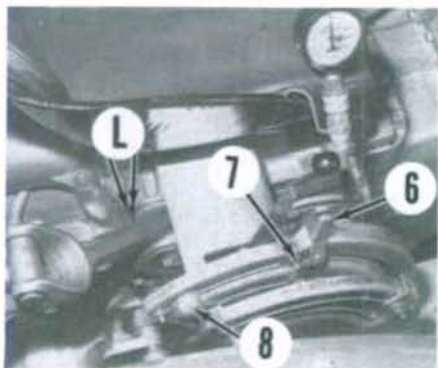

Fig. 178—Refer to text for checking and adjusting transport stop. Pressure control model shown.

- L, Scribe lines
- 7, Transport stop
- 6, Inner quadrant lever
- 8, Draft control lever

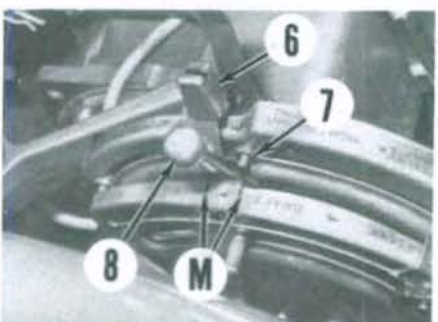
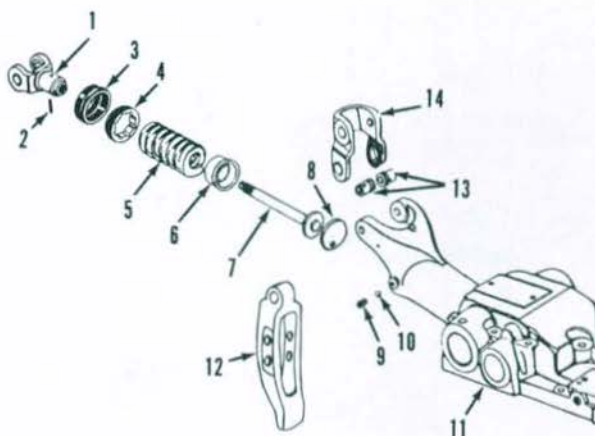

Fig. 179—View showing sector marks (M) on draft control quadrant. Refer to text for checking and adjusting draft control.

Fig. 180—The hitch master control spring is located in rear of hydraulic lift cover. Implement draft load is transmitted through the spring to actuate draft control linkage.

- 1. Clevis head
- 2. Pin
- 3. Cover
- 4. Adjusting nut
- 5. Control spring
- 6. Spring seat
- 7. Plunger
- 8. Overload stop
- 9. Set screw
- 10. Nylon plug
- 11. Lift cover
- 12. Control beam
- 13. Bushings
- 14. Clevis rocker link



with implement held steady at a selected height.

If pressures are not as described, refer to appropriate paragraph 199 or 203 for adjustment procedure.

ADJUSTMENTS

Models With Dashpot Mounted on Lift Cover

**194. MASTER CONTROL SPRING.** To adjust master control spring (5—Fig. 180), disconnect control beam (12) or top link (depending on what type spring head is used) from spring head (1). If a clevis type head is used, remove bolts attaching clevis rocker link (14) to lift cover casting (11). Position draft control lever fully down. Check for end play in spring by pulling and pushing on spring head. If end play is present, loosen set screw (9) in side of lift housing and pull back rubber boot (3) to expose adjusting nut (4). Turn adjusting nut into or out of lift cover until end play is just eliminated.

**NOTE:** End play will be present if adjusting nut is either too loose or too tight.

If end play cannot be eliminated by turning adjusting nut, it will be necessary to remove control spring assembly and check internal adjustment of spring as follows: Unscrew adjusting nut and withdraw spring assembly from lift cover. Grasp spring while holding head and attempt to rotate spring on plunger (7). Spring should fit snugly with no end play, but should still turn with moderate effort. If adjustment is incorrect, drive pin (2) out of head and thread plunger into or out of head until end play is just eliminated. Tighten plunger further, if necessary, until slot is aligned and reinstall pin (2). Install control spring assembly into housing and turn adjusting nut until end play is just eliminated. Install nylon plug (10) and tighten set screw (9).

**195. INSTALLED ADJUSTMENTS.** The following adjustments should be performed with lift cover installed and tractor operational. Accomplish the adjustments in the sequence listed. Remove the response control cover plate from right side. Be sure that oil is maintained at level of lowest threaded mounting hole for response control cover making it necessary to temporarily reinstall the lower cap screw. Be sure that control valve adjusting screw (4—Fig. 181) and roller (3) are correctly installed. If pressure control type, adjusting screw (5) should be threaded into vertical lever (1), but should not contact diaphragm plunger.

On all models, make sure lift arms will fall freely of their own weight from raised position with engine not running and quadrant lever down. Side play of lift arms should be the least possible while still permitting free movement, and is adjusted by cap screws securing lift arms to shaft.

Check control spring adjustment as outlined in paragraph 194 and adjust if necessary. Set initial position of transport stop and lever friction as described in paragraph 187.

Connect a 35000 kPa (5000 psi) pressure gage to port in lift cover as shown in Fig. 176. Attach an implement or 400 Kg, (900 pound) weight to lift links. Operate engine and raise and lower weight several times to expel air and warm oil to about 50°C (120°F). Lower lift links and stop engine.

**196. CONTROL VALVE.** To adjust control valve, first move both quadrant levers to "TRANSPORT" position. Then, install a wedge between dashpot piston rod and collar as shown in Fig. 182 to hold dashpot and linkage in neutral position during adjustment.

**NOTE:** Be careful when positioning wedge and do not dislodge roller (3—Fig. 181) from control lever, or vertical lever (1) from its pivot pin.

Start engine and run at low idle, move draft control lever fully down and turn adjusting screw (4—Fig. 182) INTO lever until lift links just begin to rise. Turn adjusting screw OUT after links are just above horizontal so lift links stop rising. This will synchronize pump control valve and internal linkage at neutral position. Push the control lever (with roller) forward to lower if lift links raise too high (above horizontal), then readjust screw (4). Shut off engine and move draft control lever to "TRANSPORT," then remove adjustment wedge (W).

**197. TRANSPORT STOP.** Adjust transport stop with weights still attached to lift links. Run engine at idle speed with draft control lever in full "UP" position.

On nonpressure control models, move inner quadrant lever past the transfer stop bracket full up on quadrant. Be sure relief valve is opening, then scribe lines across lift arms and lift cover (L—Fig. 183). Move the inner quadrant control lever (position control) down toward

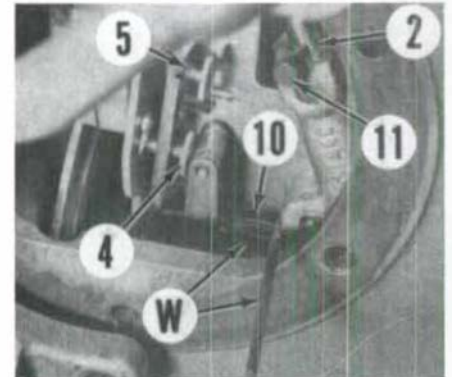

Fig. 182—A wedge (W) must be placed between dashpot piston rod end collar to hold linkage in neutral during control valve adjustment. Refer to text for adjustment procedure.

- 2. Dashpot plunger
- 4. Control valve adjusting screw
- 5. Pressure control adjusting screw
- 10. Dashpot guide screw
- 11. Set screw

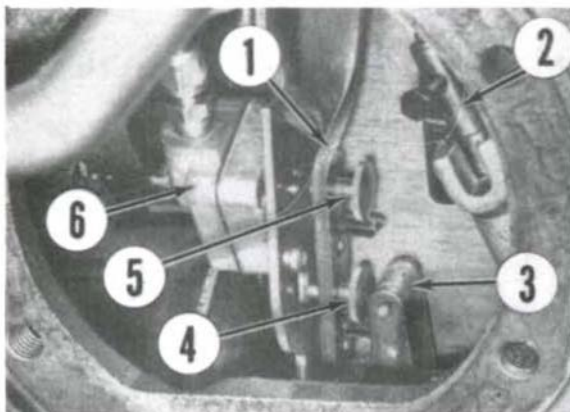

Fig. 181—View of lift housing through opening for response control cover. Refer to text for adjustments.

- 1. Vertical lever
- 2. Dashpot plunger
- 3. Roller
- 4. Control valve adjusting screw
- 5. Pressure control diaphragm adjusting screw
- 6. Pressure control diaphragm

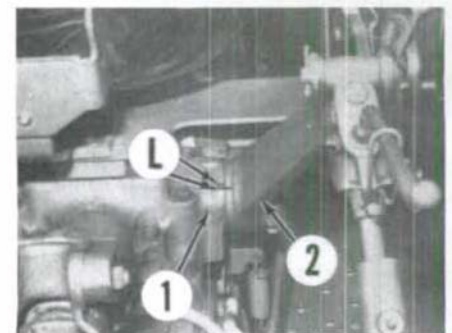

Fig. 183—Scribe lines (L) on lift cover (1) and lift arm (2) are used when adjusting transport stop. Refer to text.

transport until scribed lines are 3.2-3.9 mm (1/8-5/32 inch) apart. Adjust transport stop to hold control lever at this point on quadrant. If stop adjustment is impossible, lift cover internal linkage may be incorrectly adjusted, damaged or binding. Check linkage through right side opening. Also check relief valve operation through this opening.

On pressure control models, move inner quadrant lever into "CONSTANT PUMPING" range at "PRESSURE" control side of transport stop, then scribe a line (L--Fig. 183) across lift arm and lift cover hub. Move inner quadrant lever to "POSITION" side of transport stop, firmly against stop pin. Measure distance between the scribed lines. If not within 3.2-3.9 mm (1/8-5/32 inch), loosen control quadrant mounting bolts and move only the inner quadrant to correct the setting.

198. DRAFT CONTROL. Adjust draft control as follows: Disconnect top link, but leave weight or implement attached to lower links. Run engine at idle speed. Move inner quadrant lever to "TRANSPORT" position and move draft control lever downward until weight just begins to fall. Position draft lever so weight remains suspended in approximately mid-position, then note location of lever. If

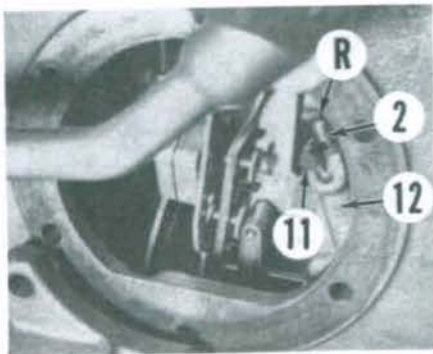
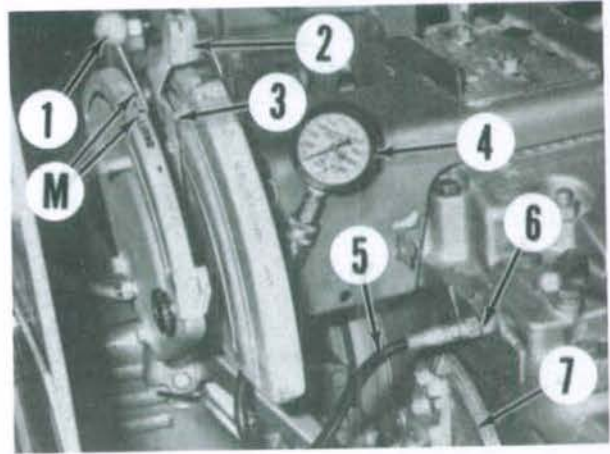

Fig. 184—View of response control plunger adjustment rod (R), plunger (2), set screw (11) and dashpot housing (12).

Fig. 186—View of 3-point lift controls for models equipped with pressure control. Connect 35000 kPa (5000 psi) pressure gage (4) at lift cover port (6) to check system pressure.

- M, Sector marks
- 1. Draft control lever
- 2. Inner quadrant lever
- 3. Transport stop
- 4. Pressure gage
- 5. Hose
- 6. Test port
- 7. Response control side cover



draft lever is not within 6.4 mm (1/4 inch) of sector marks (M—Fig.179), loosen screws securing draft quadrant and relocate quadrant until sector marks are correctly located. Tighten retaining screws, then recheck adjustment.

199. PRESSURE CONTROL. To adjust pressure control, proceed as follows: Implement or weight must be attached to lift links and pressure gage connected to lift cover as shown in Fig. 176. Run engine at low speed and move draft control lever fully "UP." Move inner quadrant lever forward as far as possible, then move lever rearward into "CONSTANT PUMPING" and note pressure gage reading.

If pressure is not within 17240-17930 kPa (2500-2600 psi), move inner lever fully down and adjust pressure control valve tube (accessible through response cover opening). Turn tube clockwise to increase, or counterclockwise to decrease pressure to recommended setting.

When pressure is within limits, turn pressure control adjusting screw (5—Fig. 181) clockwise until vertical lever (1) begins to pulsate, then turn screw counterclockwise until pulsating stops and pressure does not fluctuate more than 700 kPa (100 psi).

200. RESPONSE CONTROL. To adjust response control, loosen plunger set screw (11—Fig. 184), push rod (R) down, then retighten set screw to hold rod in place. Move the response control lever to "FAST" position, then reinstall response side cover (without outer cover) onto housing. Move response control lever to place it about 6.4 mm (1/4 inch) from "SLOW" position. Remove access plug from side cover. Insert a wrench through access opening and loosen set screw to allow plunger to release and contact response lever shaft. Retighten set screw. Install access plug and outer cover.

Fill housing to full mark on dipstick with recommended oil. Start engine and raise and lower lift links several times using draft control lever to purge air from dashpot. Check for proper operation of hitch.

ADJUSTMENTS

Models Without Dashpot on Lift Cover

201. MASTER CONTROL SPRING. To adjust master control spring (7—Fig. 185), disconnect upper link control beam from spring head (10). Position draft control lever fully down. Check for end play in spring by pulling and pushing on spring head. If end play is present, loosen set screw (3) in side of lift housing and pull back rubber boot (9) to expose adjusting nut (8). Turn adjusting nut into or out of lift cover until end play is just eliminated.

NOTE: End play will be present if adjusting nut is either too loose or too tight.

If end play cannot be eliminated by turning adjusting nut, it will be necessary to remove control spring assembly and check internal adjustment of spring as follows: Unscrew adjusting nut and withdraw spring assembly from

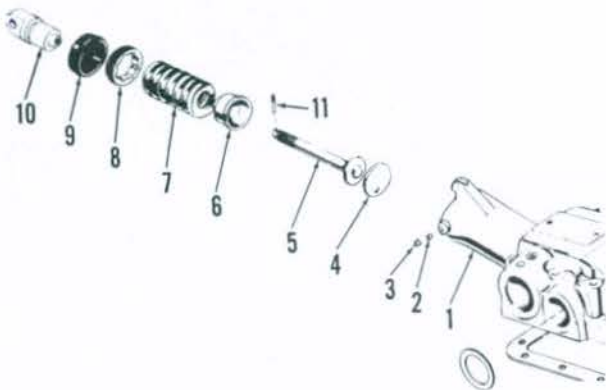

Fig. 185—The master control spring is located in rear of hydraulic lift cover.

- 1. Lift cover
- 2. Nylon plug
- 3. Set screw
- 4. Overload stop
- 5. Plunger
- 6. Spring seat
- 7. Control spring
- 8. Adjusting nut
- 9. Cover
- 10. Spring head
- 11. Pin

lift cover. Grasp spring while holding head and attempt to rotate spring on plunger (5). Spring should fit snugly with no end play, but should still turn with moderate effort. If adjustment is incorrect, drive pin (11) out of head and thread plunger into or out of head until end play is just eliminated. Tighten plunger further, if necessary, until slot is aligned and reinstall pin (11).

Reinstall control spring assembly into lift housing and turn adjusting nut (8) until end play is just eliminated. Install nylon plug (2) and tighten set screw (3).

**202. INSTALLED ADJUSTMENTS.** The following adjustments should be performed with lift cover installed and tractor operational. Accomplish the adjustments in the sequence listed. Maintain oil level at the lowest mounting bolt hole (5—Fig. 187) of response control cover plate. Connect a 35000 kPa (5000 psi) pressure gage (4—Fig. 186) to test port (6) in lift cover as shown.

Remove response control cover plate and check that diaphragm adjusting screw (1—Fig. 187), if so equipped, has at least three threads extending through diaphragm lever (2) for an initial setting. Be sure oil is to level of lower bolt hole (5).

Check to make sure lift arms fall freely of their own weight from raised position with engine not running and quadrant lever down. Lift arm side clearance is adjusted by cap screws securing lift arms to rockshaft. Check transport stop initial setting as outlined in paragraph 187.

Attach an implement or weight of approximately 400 Kg (900 pounds) to lift arms. Temporarily reinstall response control side cover, then run engine and

raise and lower lift links several times to expel air and warm oil to about 50°C (120°F).

**203. PRESSURE CONTROL.** Run engine at 1500 rpm and move draft control lever to full "UP" position. On models with pressure control, move inner quadrant lever to "CONSTANT PUMPING" position and observe pressure indicated by gage (4—Fig. 186). On models without pressure control, move inner lever past the transport stop

(3—Fig. 188) and observe pressure reading. Pressure for all models should be 17240-17930 kPa (2500-2600 psi) and should not fluctuate more than 700 kPa (100 psi).

If pressure fluctuates more than 700 kPa (100 psi), adjust diaphragm screw (1—Fig. 187) as follows: Stop engine, move quadrant inner lever fully down and remove response control side cover. Turn diaphragm adjusting screw out ½ turn. Temporarily install response control cover and repeat pressure check. Ad-

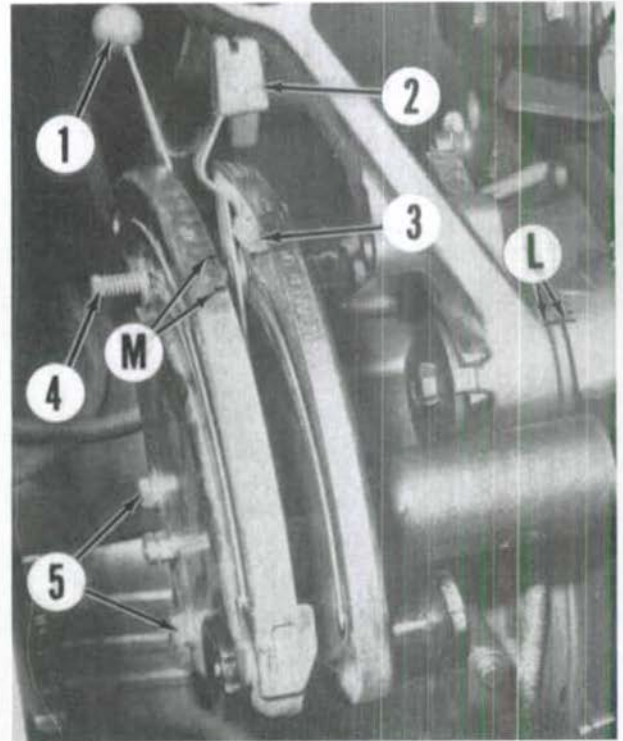

**Fig. 188—View of controls for models without pressure control. Sector marks (M) and scribed lines (L) are used when adjusting control linkage. Refer to text.**

1. Draft control lever
2. Inner quadrant lever
3. Transport stop
4. Friction spring
5. Cap screws

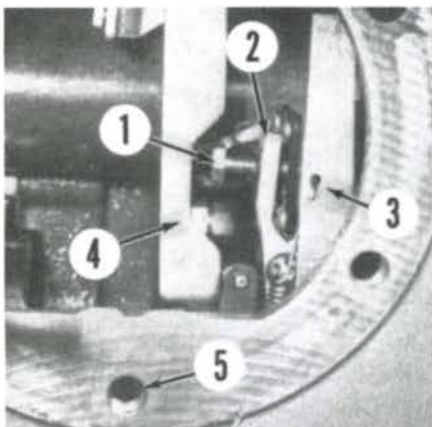

**Fig. 187—Access to internal linkage adjustment points is obtained through response control cover opening. Oil should be at level of hole (5).**

1. Diaphragm adjusting screw
2. Diaphragm lever
3. Response valve lever
4. Vertical lever

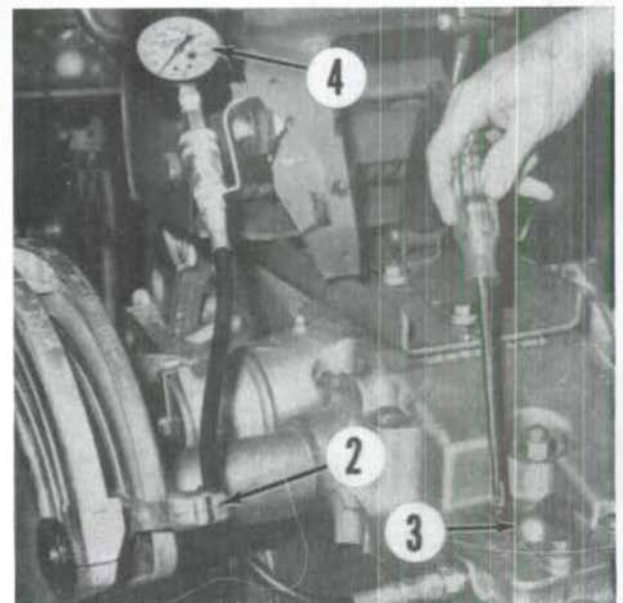

**Fig. 189—Pressure is adjusted with screwdriver through rear bolt hole in transfer plate (3). Refer to text.**

just as described 1/2 turn at a time until pressure fluctuation is eliminated.

If maximum system pressure is not within specified range of 17240-17930 kPa (2500-2600 psi), adjust maximum pressure setting as follows: Place inner lever fully down on quadrant. Remove rear cap screw from transfer cover (3—Fig. 189) and use a screwdriver through bolt hole in cover to turn pressure adjusting screw as necessary. Each 1/2 turn of screw will change pressure approximately 350-700 kPa (50-100 psi). Reinstall transfer cover retaining cap screw and recheck for correct pressure.

**204. TRANSPORT STOP.** To adjust transport stop (3—Fig. 186 or 188) run engine at idle speed. With implement or weights attached to lift links, move draft control lever to fully "UP" position.

On models without pressure control, move inner quadrant lever past transport stop to "CONSTANT PUMPING." Scribe lines (L—Fig. 188) across lift arm and lift cover casting. Move in-

ner lever downward on quadrant towards the transport stop until the scribed lines are separated 3.2-3.9 mm (1/8-5/32 inch). Adjust the transport stop to hold the inner lever at this point. If necessary, the quadrant retaining bolts can be loosened and inner quadrant moved for additional adjustment.

On pressure control models, move inner quadrant lever to "CONSTANT PUMPING" on pressure side of transport stop. Scribe a line across lift arm and lift casting (similar to L—Fig. 188), then move inner lever to "POSITION" side of transport stop. Measure the distance that scribed lines are separated. If separation is not within range of 3.2-3.9 mm (1/8-5/32 inch), loosen cap screws securing quadrant and move inner quadrant only to obtain correct setting.

**205. DRAFT CONTROL.** To adjust draft control, disconnect the top link, but leave implement or weights attached to lower links. Run engine at low speed, place inner quadrant lever at "TRANSPORT" and move draft control lever downward on quadrant until

weight just begins to fall. Position draft control lever in quadrant where weight remains suspended in midposition and note location of draft lever. If lever is not within 6.4 mm (1/4 inch) of sector marks (M—Fig. 186 or 188), loosen screws (5—Fig. 188) securing draft indicating quadrant. Move draft quadrant while holding draft lever until sector marks align with lever. Be careful not to move inner quadrant indicator while making this adjustment.

**206. RESPONSE CONTROL.** To adjust response control, first remove outer cover from response control side cover. Place response lever (1—Fig. 190) 6.4 mm (1/4 inch) from "SLOW" position, then loosen retaining screw (3). Move inner plate (2) until cam block contacts the "slide" valve lever (located inside housing on pump). Tighten retaining screw to secure the adjustment.

**LIFT COVER**

**Models With Dashpot Mounted on Cover**

**207. REMOVE AND REINSTALL.** To remove hydraulic lift cover, first remove seat and seat frame. Disconnect upper lift links from lift arms and remove center link. On models so equipped, remove control beam from control spring head (2B—Fig. 192). On all

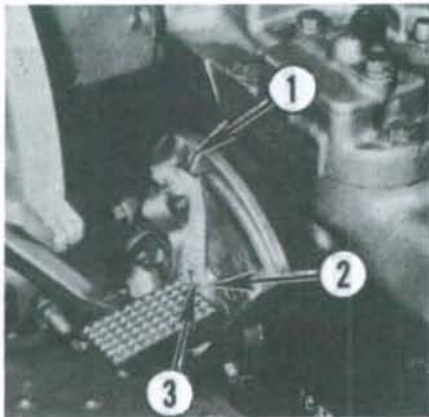

Fig. 190—View of response control side cover with outer cover removed.

- 1. Response control lever
- 2. Inner plate
- 3. Retaining screw

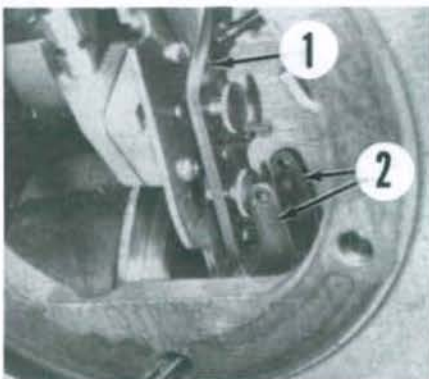

Fig. 191—Remove roller from top of control valve lever (2) before removing lift cover, and be sure vertical lever (1) is located to rear of valve lever when reinstalling lift cover.

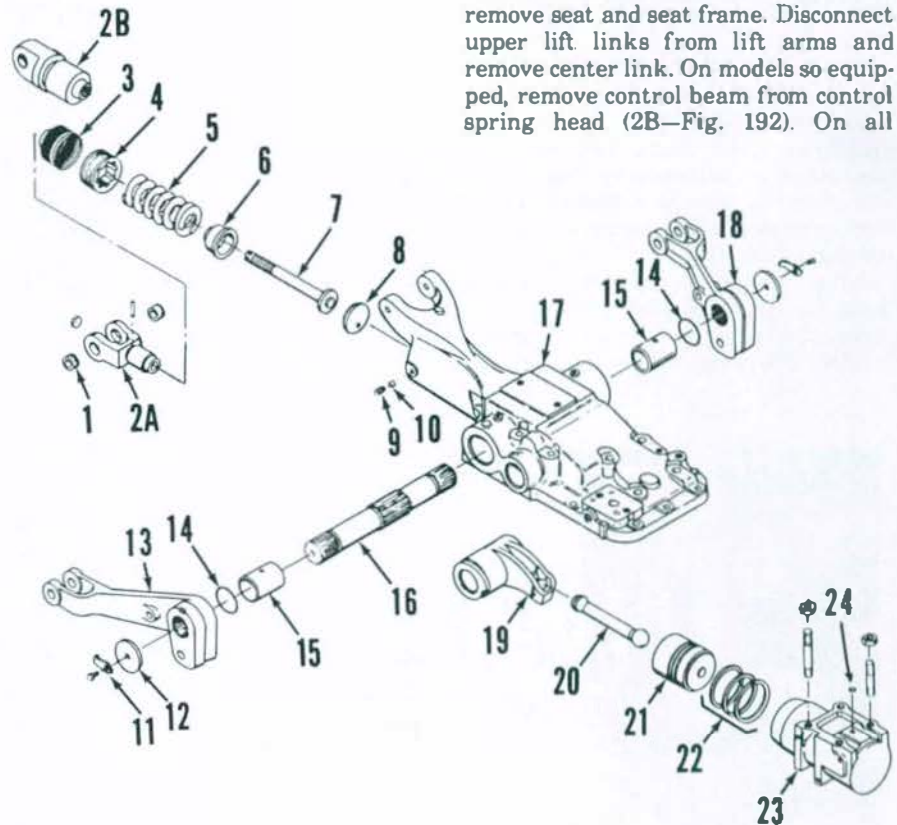

Fig. 192—Exploded view of hydraulic lift cover, master control spring, rockshaft, lift cylinder and associated parts.

- 1. Bushing
- 2A. Clevis head
- 2B. Plain head
- 3. Rubber boot
- 4. Adjusting nut
- 5. Master control spring
- 6. Spring seat
- 7. Plunger
- 8. Overload stop
- 9. Set screw
- 10. Nylon plug
- 11. Lock clip
- 12. Washer
- 13. Lift arm, R.H.
- 14. "O" ring
- 15. Bushing
- 16. Rockshaft
- 17. Lift cover
- 18. Lift arm, R.H.
- 19. Rockshaft arm
- 20. Piston rod
- 21. Piston
- 22. Piston rings
- 23. Lift cylinder
- 24. "O" ring

models, drain hydraulic system fluid down until response control side cover can be removed. Reaching through side cover opening, spread pump control valve lever arms (2—Fig. 191) and remove roller. Remove transfer plate or auxiliary valve. Remove lift cover mounting cap screws, then carefully remove cover using a suitable hoist.

When reinstalling lift cover, it is recommended that two guide dowels be installed to aid in aligning cover with differential housing. Be sure to guide the hydraulic standpipe into lift pump as cover is lowered onto housing. Be sure vertical control lever (1) is located to the rear of control valve lever (2). Reinstall roller in control valve lever. Tighten lift cover cap screws to 75 N · m (55 ft.-lbs.) torque. Complete installation by reversing the removal procedure.

**208. OVERHAUL.** To disassemble, first unscrew control spring adjusting nut (4—Fig. 192) and withdraw control spring assembly from lift cover. Remove dashpot assembly (53—Fig. 193). If equipped with pressure control, remove diaphragm (52), pressure control valve

Fig. 194—Exploded view of hydraulic lift controls.

1. Draft control quadrant
2. Draft control lever
3. Position control lever
4. Position control quadrant
5. "O" ring
6. "O" ring
7. Support
8. Set screw
9. Position control shaft
10. Rollers
11. Draft control shaft
12. "O" ring

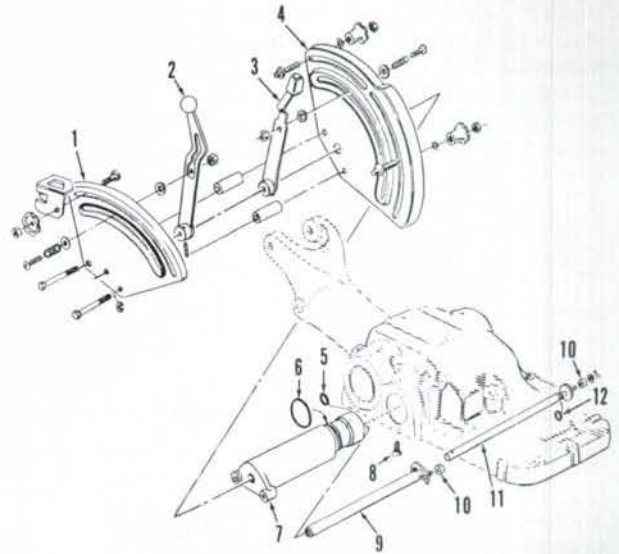

(51) and pressure control lever (45). Remove adjusting bolt (48). Remove return spring (38). Remove set screw (8—Fig. 194) securing control quadrant in lift cover. Hold draft and position levers (37 and 40—Fig. 193) away from quadrant cams (32 and 33), then remove

quadrant assembly from lift cover. Compress springs (42), then install cotter pins through holes in ends of spring rods to hold springs in place. Remove bolts securing support bracket (47) to cylinder, then remove vertical lever (43) with control levers and support bracket. Remove set screw (30), then pull pivot shaft (31) from cams and lift cover. Remove control cams (32 and 33) with rods and springs.

To remove rockshaft (16—Fig. 192) and lift cylinder (23), first remove left-hand lift arm (18). Slide shaft with right-hand arm out right side of lift cover. Remove bushings (15) and "O" rings (14). Remove rockshaft arm (19) with rod (20) from lift cover. Remove stud nuts securing lift cylinder and remove cylinder from lift housing. Remove piston from cylinder.

Inspect all parts for wear, scoring or other damage and renew if necessary. Be sure to renew all "O" rings.

To reassemble, install cylinder on lift cover and tighten stud nuts nearest front of cover to 197-257 N · m (145-190 ft.-lbs.) torque and nuts nearest rear of cover to 278-332 N · m (205-245 ft.-lbs.) torque. Stagger piston ring end gaps around piston, then use a suitable ring compressor to assemble piston in cylinder. Install rockshaft in lift cover aligning master spline on shaft with blind splines inside rockshaft arm and lift arms.

Reinstall control linkage by reversing the disassembly procedure. Adjust cam pivot shaft (31—Fig. 193) to obtain minimum amount of side play in linkage, but cams should move freely without binding. Adjust linkage as outlined in paragraph 211.

**209. DRAFT RESPONSE DASHPOT.** The draft response dashpot assembly (53—Fig. 193) attaches to lever

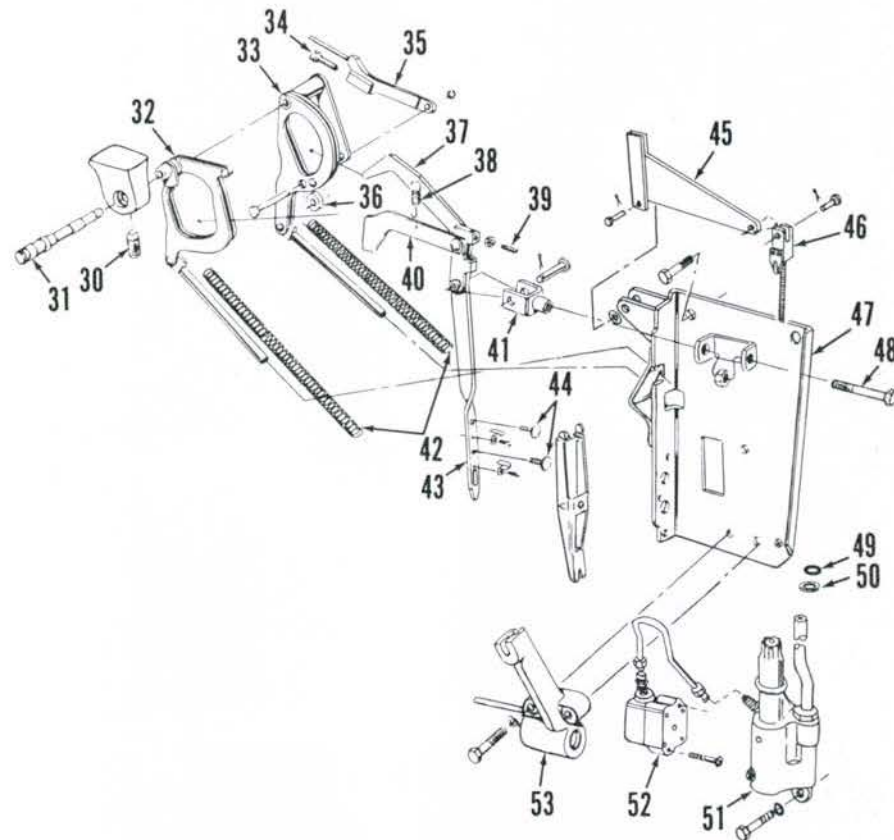

Fig. 193—Exploded view of hydraulic lift internal control linkage used on models equipped with pressure control. On models without pressure control, items 45, 46, 51 and 52 are not used.

- |                          |                              |                                    |                            |
|--------------------------|------------------------------|------------------------------------|----------------------------|
| 30. Set screw            | 37. Draft control lever      | 42. Springs                        | 47. Support bracket        |
| 31. Pivot shaft          | 38. Return spring            | 43. Vertical lever                 | 48. Draft adjusting bolt   |
| 32. Position control cam | 39. Position adjusting screw | 44. Adjusting screws               | 49. "O" ring               |
| 33. Draft control cam    | 40. Position control lever   | 45. Pressure control lever         | 50. Washer                 |
| 34. Stop screw           | 41. Pivot yoke               | 46. Pressure control adjusting rod | 51. Pressure control valve |
| 35. Draft control rod    |                              |                                    | 52. Diaphragm assy.        |
| 36. Roller               |                              |                                    | 53. Dashpot                |

bracket, and can be removed after removing lift cover as outlined in paragraph 207.

To disassemble the dashpot, loosen adjusting screw (18—Fig. 195) and remove adjustment rod (20) and spring (19). Invert the housing and remove plunger (17), needle (15) and spring (14). Depress piston rod and guide (8) and remove snap ring (7), then remove spring (9), piston (10) and spring (11). Expansion plugs or guide (12) can be removed from body if renewal is indicated.

Assemble by reversing the disassembly procedure using Fig. 195 as a guide. Adjust as outlined in paragraph 200 after tractor is assembled.

**210. PRESSURE CONTROL VALVE AND DIAPHRAGM.** The pressure control valve shown exploded in Fig. 196 serves the dual purpose of providing pressure relief for the main hydraulic pump during normal operation and providing weight transfer for added traction when using some types of pulled or mounted implements.

Pressure line (2) is connected to welded tee-block in standpipe, and ram cylinder pressure acts against servo piston (7) which is held closed by the variable rate spring (3). The spring is compressed to the maximum when inner quadrant control lever is in "POSITION CONTROL" or "CONSTANT PUMPING" position, and is released at a uniform rate as lever is moved to low end of "PRESSURE CONTROL" sector of quadrant. When pressure valve is correctly adjusted and operating properly, pressure in the ram cylinder circuit should be 140-275 kPa (20-40 psi) with inner quadrant control lever at extreme "LOW" end of quadrant and should increase at a steady rate as lever is moved, until the specified relief pressure is obtained as lever moves into "CONSTANT PUMPING" sector of quadrant.

The servo piston (7) and matched sleeve (8) connect the control diaphragm assembly (Fig. 197) to control passage of pressure valve. When servo piston is against stop pin in valve body (9—Fig. 196) the diaphragm passage is open to reservoir. As pressure builds up in lift cylinder circuit and piston (7) moves upward against spring pressure,

the diaphragm exhaust passage is closed. When the pressure limit is reached, fluid passes servo piston to diaphragm passage, extending the diaphragm plunger to move the main hydraulic pump control arm to neutral.

Relief valve (10) is preset at a slightly higher pressure than diaphragm return spring (2—Fig. 197). The valve provides a safety relief passage if diaphragm plunger malfunctions or system is improperly adjusted.

To disassemble the pressure control valve, refer to Fig. 196 and proceed as follows: Withdraw adjusting tube (1) and spring (3), then unscrew and remove pilot (5). Using needlenose pliers, carefully withdraw guide (7). Remove piston seat (8) using a hooked wire. Relief valve (10) and spring (11) can be removed after removing snap ring (12).

Guide (7) and seat (8) are available only as a matched set. All other parts are available individually. Examine all parts carefully and renew any which are worn, scored or damaged.

Assemble the pressure control valve by reversing the disassembly procedure. Adjust as outlined in paragraph 199 after lift cover is reinstalled.

**211. INTERNAL LINKAGE ADJUSTMENT.** The following internal lift linkage adjustments must be performed before reinstalling lift cover. Invert the lift cover in a fixture or on a bench. Block up the cover as necessary so rockshaft can be moved to the normal raised "TRANSPORT" position.

Check and adjust master control spring (5—Fig. 192) as outlined in paragraph 194. Make sure draft control rod does not contact spring plunger when adjusting master control spring. Move draft control lever to fully lowered position on quadrant and, if necessary, place a wedge between lift cover casting and draft control rod adjusting screw.

**212. DRAFT CONTROL ROD.** To adjust draft control rod (6—Fig. 198), first move draft control lever to full "UP"

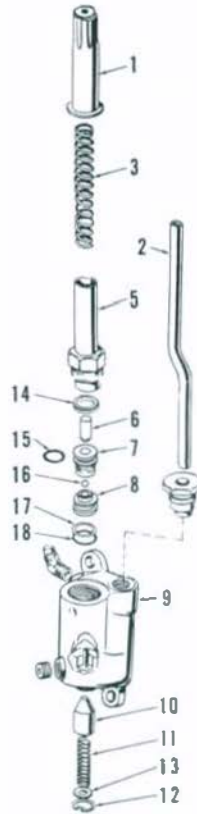

Fig. 196—Exploded view of pressure control valve.

- |                    |                   |
|--------------------|-------------------|
| 1. Adjusting tube  | 10. Valve         |
| 2. Pressure tube   | 11. Spring        |
| 3. Pressure spring | 12. Snap ring     |
| 4. Pilot           | 13. Washer        |
| 5. Plunger         | 14. Spring        |
| 6. Guide           | 15. "O" ring      |
| 7. Seal            | 16. Bell          |
| 8. Body            | 17. Backup washer |
|                    | 18. "O" ring      |

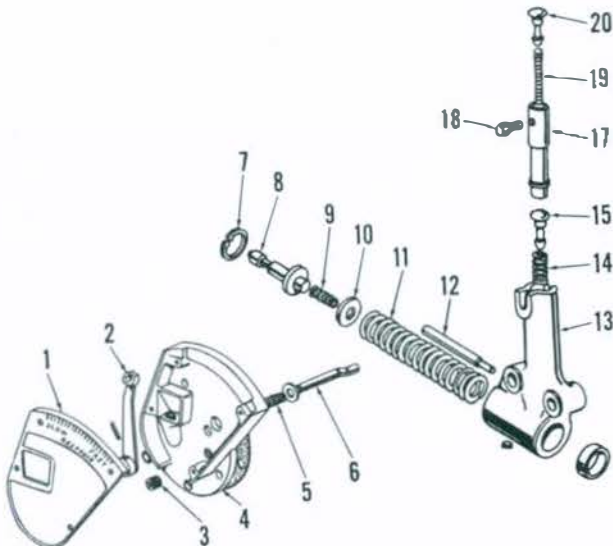

Fig. 195—Draft response dashpot, control cover and associated parts.

- |                       |
|-----------------------|
| 1. Control cover      |
| 2. Response lever     |
| 3. Port plug          |
| 4. Side cover         |
| 5. Spring             |
| 6. Draft response cam |
| 7. Snap ring          |
| 8. Plunger & bushing  |
| 9. Spring             |
| 10. Dashpot piston    |
| 11. Spring            |
| 12. Guide             |
| 13. Dashpot           |
| 14. Spring            |
| 15. Response needle   |
| 17. Valve plunger     |
| 18. Adjusting screw   |
| 19. Spring            |
| 20. Needle            |

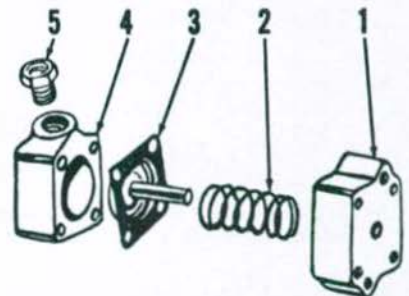

Fig. 197—Exploded view of pressure control diaphragm.

- |           |              |
|-----------|--------------|
| 1. Cover  | 3. Diaphragm |
| 2. Spring | 4. Body      |

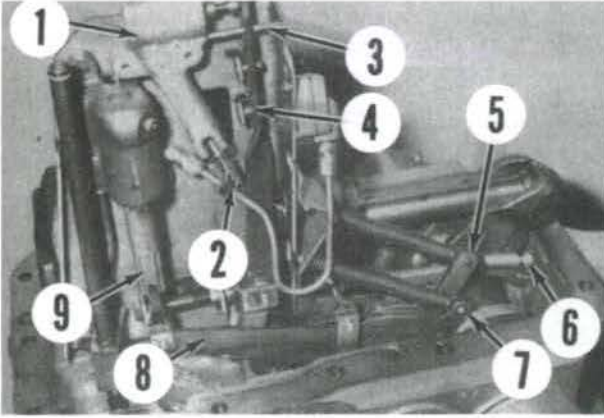

Fig. 198—View of lift cover internal control linkage. Pressure control model is shown.

1. Dashpot
2. Response control plunger
3. Guide rod
4. Vertical lever
5. Draft control cam
6. Draft control rod
7. Position control cam
8. Pressure control lever
9. Pressure control adjusting tube

position. Then, adjust control rod cap screw (S—Fig. 199) until clearance (A) between cap screw and lift cover casting is 4.1-4.5 mm (0.160-0.180 inch).

213. DRAFT CONTROL LINKAGE.

To adjust draft control linkage, first check for correct initial setting of transport stop as follows: On models without pressure control, make sure that center of rear bolt holding transport stop plate is 11 mm (7/16 inch) from rear of slot in quadrant. On models with pressure control, be sure that transport stop is positioned at rear of quadrant slot.

Move inner quadrant lever against transport stop, then loosen quadrant attaching cap screws and center both quadrants in the mounting slots. Tighten quadrant attaching screws. Move draft control lever between the two sector marks on the draft quadrant.

On pressure control models, disconnect pressure control lever (8—Fig. 198) from pressure control valve and rear pivot pin, and remove control lever. Remove pressure control adjusting tube (9) with rod, clevis and spring from pressure control valve.

On all models, install a wedge (1—Fig. 200) to hold dashpot plunger in fixed position against vertical lever. Loosen position control adjusting screw (6) just

enough to free the position control lever. Attach a spring scale to vertical lever, and apply 1.4 Kg (3 pounds) of pull against lever while checking clearance between lever and dashpot plunger. Turn draft adjusting bolt (5), if necessary, to provide correct clearance of 0-0.05 mm (0-0.002 inch). Tighten adjusting screw locknut, then recheck clearance to be sure setting is correct.

214. POSITION CONTROL. To adjust position control linkage, be sure wedge (1—Fig. 201) is still in place holding dashpot fixed against vertical lever. Position a spacer block (6) that is 16.15

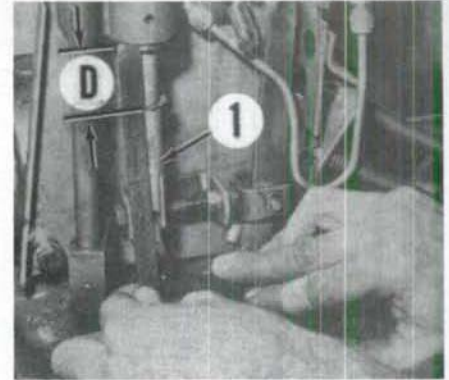

Fig. 202—Measure distance (D) between bottom (notched end) of pressure adjusting tube (1) and pressure control valve housing as shown. Refer to text.

mm (0.636 inch) thick between lift cover casting and rockshaft arm (5) making sure arm rests against spacer. Move draft control lever to full "UP" position of quadrant and move position control lever to transport stop.

Use spring scale attached to vertical lever to apply 1.4 Kg (3 pounds) pull to lever, then check that clearance between lever and dashpot plunger is 0-0.05 mm (0-0.002 inch). Turn position adjusting screw (4), if necessary, to set correct clearance. Tighten adjusting screw jam nut, then recheck clearance.

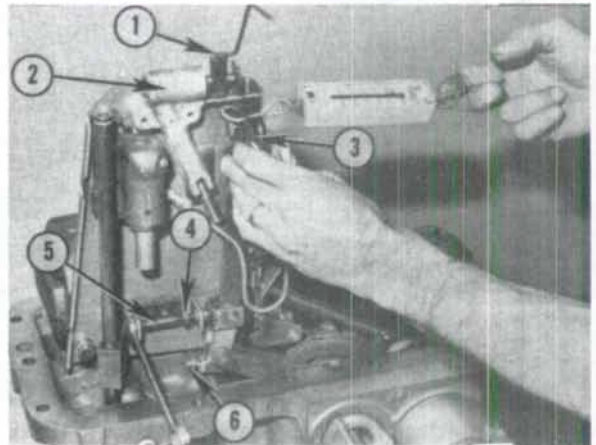

Fig. 200—View showing adjustment of draft control linkage. Refer to text for procedure.

1. Wedge
2. Dashpot
3. Feeler gage
4. Locknut
5. Draft adjusting bolt
6. Position adjusting screw

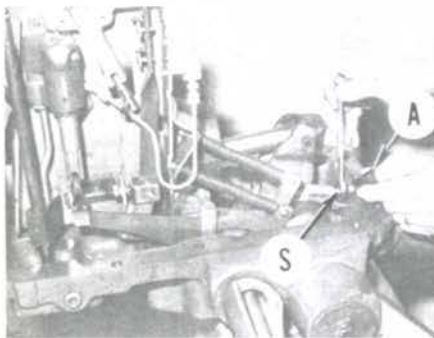

Fig. 199—Turn draft control rod adjusting screw (S) until clearance (A) between head of screw and lift cover casting is 4.1-4.5 mm (0.160-0.180 inch). Draft control lever must be in fully "UP" position.

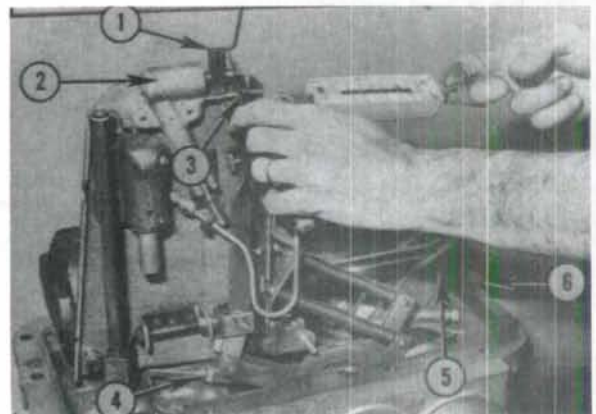

Fig. 201—View showing adjustment of position control linkage. Refer to text.

1. Wedge
2. Dashpot
3. Feeler gage
4. Position adjusting screw
5. Rockshaft arm
6. Spacer



215. **PRESSURE CONTROL VALVE.** On models equipped with pressure control, reinstall spring and adjusting tube (9—Fig. 198) into pressure control valve. Attach pressure control lever (8) to clevis and pivot pin. Move draft control lever fully "UP" and move inner quadrant



Fig. 204—View of auxiliary valve, return filter and seat support being removed as an assembly.

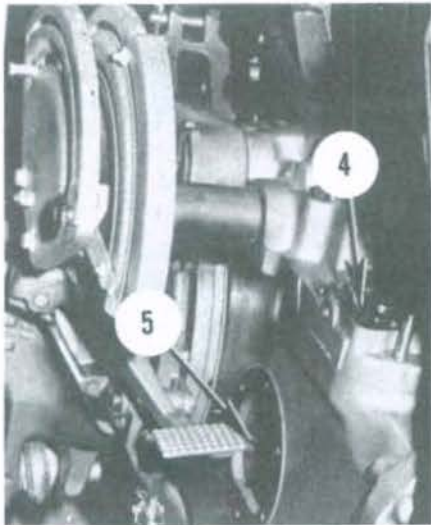

Fig. 205—The response side cover (5) and transfer cap (4) must be removed and standpipe withdrawn before removing the hydraulic lift cover.

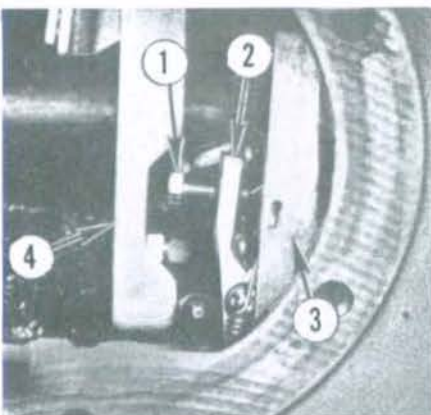

Fig. 206—The vertical lever (4) must be positioned as shown with cover reinstalled.

- 1. Adjusting screw
- 2. Diaphragm lever
- 3. Slide valve lever
- 4. Vertical lever

lever to lowest setting within "PRESSURE" range of quadrant. Hold pressure control lever down securely against actuating cam, then measure distance between bottom of adjusting tube and pressure control valve housing as shown in Fig. 202. Turn adjusting tube as required until distance (D) is 31.75-34.93 mm (1-1/4 to 1-3/8 inches).

**LIFT COVER**

**Models Without Dashpot Mounted on Cover**

216. **REMOVE AND REINSTALL.** Disconnect lift links from lift arms, and remove upper link and control beam from master control spring head. Disconnect wiring and hydraulic lines as necessary. Detach auxiliary valve remote couplers (if so equipped) from

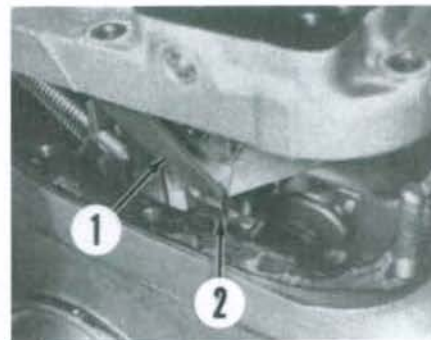

Fig. 207—On pressure control models, be sure pressure control lever (1) engages "butterfly" bracket when installing lift cover.

mounting bracket. Unbolt and remove seat support with auxiliary valve and return filter (if so equipped) as a unit (Fig. 204). Remove transfer cap (4—Fig. 205) and response control side cover, then withdraw standpipe before removing lift cover. Remove cover attaching cap screws, install guide studs, then lift the cover from center housing.

When reinstalling, be sure vertical control lever (4—Fig. 206) on cover is to rear of hydraulic pump control lever. Be sure "butterfly" bracket (2—Fig. 207), if so equipped, is installed on top of pump servo valve and that pressure control lever (1) engages the "butterfly" as shown. Use a welding rod or similar thin rod to guide standpipe into position as shown in Fig. 208.

217. **OVERHAUL.** Refer to Figs. 209, 210 and 211 for exploded view of lift

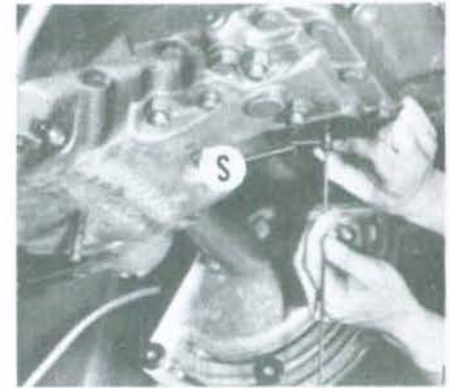

Fig. 208—Standpipe (S) can be guided into position with a piece of welding rod as shown.

Fig. 209—Hydraulic lift cover showing master control spring and associated parts.

- 1. Lift cover
- 2. Standpipe
- 3. Transfer cap
- 4. Nylon plug
- 5. Set screw
- 7. Overload stop
- 8. Plunger
- 11. Spring seat
- 12. Control spring
- 13. Adjusting nut
- 14. Cover
- 15. Pin
- 16. Clevis

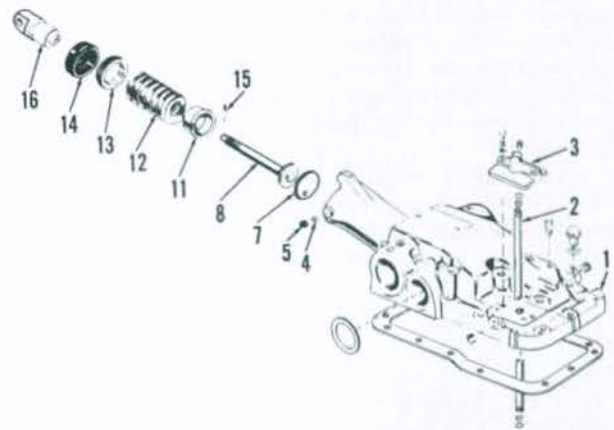
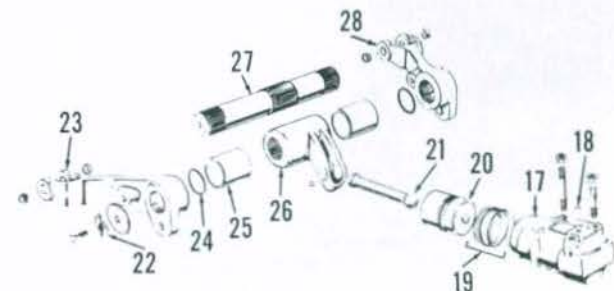

Fig. 210—Exploded view of lift cylinder, rockshaft and associated parts.

- 17. Cylinder
- 18. "O" ring
- 19. Piston rings
- 20. Piston
- 21. Connecting rod
- 22. Lock clip
- 23. Lift arm
- 24. "O" ring
- 25. Bushings
- 26. Rockshaft arm
- 27. Rockshaft
- 28. Lift arm



cover and linkage. Lift arms (23 and 28—Fig. 210), rockshaft arm (26) and rockshaft (27) all have master splines for correct assembly. Rockshaft bushings (25) are slip fit in cover bores.

To disassemble, loosen set screw (5—Fig. 209) and remove adjusting nut (13), then withdraw master control spring (12) assembly and disc (7).

On pressure control models, remove lever (50—Fig. 214). On all models, loosen the position adjusting screw (36—Fig. 215), then remove spring (38). Thread a screw into quadrant retaining pin (P), then pull or pry pin out of lift cover. Hold draft and position control fingers away from quadrant cams, then withdraw quadrant assembly from

cover.

Remove right-hand lift arm, then withdraw rockshaft (27—Fig. 210) with left-hand lift arm from cover. Remove "O" rings (24) and bushings (25) from lift cover.

Insert cotter pins through drilled holes in cam spring guide rods to hold springs (34—Fig. 214) in compressed position. Remove nut (29) retaining pivot bracket, then remove vertical lever (32) with fingers and pivot bracket as a unit.

Remove fitting at left-hand side of lift cover and loosen set screw (S—Fig. 216) retaining cam pivot shaft (P). Withdraw the pivot shaft and remove position control and draft control cams (39 and 40—Fig. 211).

Remove rockshaft arm (26—Fig. 210) and piston rod (21). Remove piston (20) from cylinder (17) and unbolt and remove cylinder from cover if necessary.

When reassembling, tighten lift cylinder retaining nuts to 160 N·m (120 ft.-lbs.) torque. Stagger end gaps of piston rings (19—Fig. 210) when installing piston. Grooved end of rod (21) is retained in rockshaft arm (26) by a set screw. Coat threads of set screw with Loctite 262, turn set screw in until it bottoms, then back it out 1/8 turn. Position rockshaft arm with rod into cover.

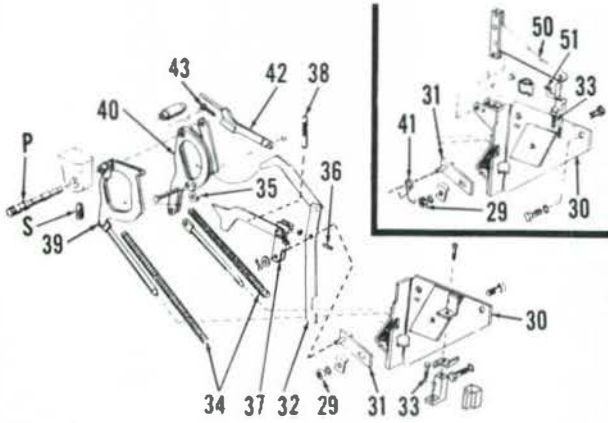

Fig. 211—Drawing of hydraulic lift linkage located on inside of lift cover. Inset shows parts that are used for pressure control models.

- P. Pivot shaft
- S. Set screw
- 29. Nut
- 30. Bracket
- 31. Pivot bracket
- 32. Vertical lever
- 33. Screw
- 34. Springs
- 35. Cam roller
- 36. Position adjusting screw
- 37. Position control finger
- 38. Spring
- 39. Position control cam
- 40. Draft control cam
- 41. Spring
- 42. Draft control rod
- 43. Stop screw
- 50. Link
- 51. Block Assy

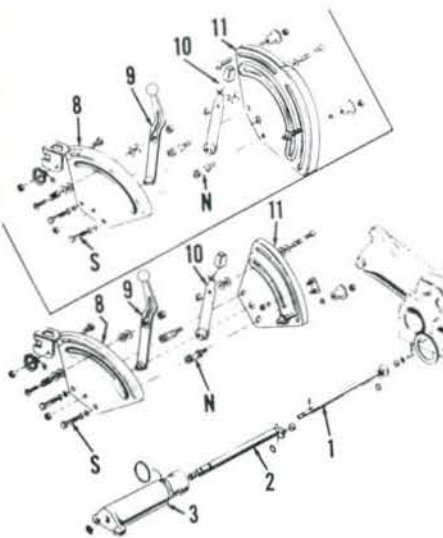

Fig. 214—View of control linkage installed in lift cover. Pressure control model is shown.

- P. Pivot pin
- 29. Nut
- 32. Vertical lever
- 34. Springs
- 36. Position adjusting screw
- 50. Pressure control lever

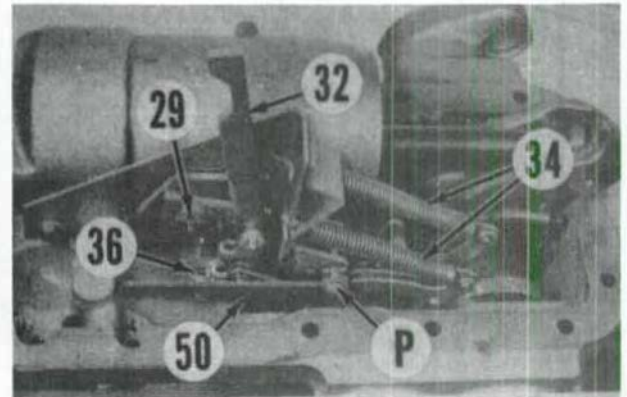

Fig. 212—Exploded view of control quadrants. Inset shows parts for pressure control models.

- N. Special nuts
- 8. Draft control quadrant
- S. Screws
- 9. Draft control lever
- 1. Draft control shaft
- 10. Position control lever
- 2. Position control shaft
- 11. Position control quadrant
- 3. Support

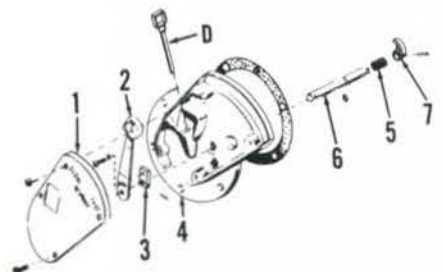

Fig. 215—View of position control linkage. Pin (P) retains control quadrant in lift cover.

- 36. Adjusting screw
- 37. Position control finger
- 38. Spring
- 39. Position control cam

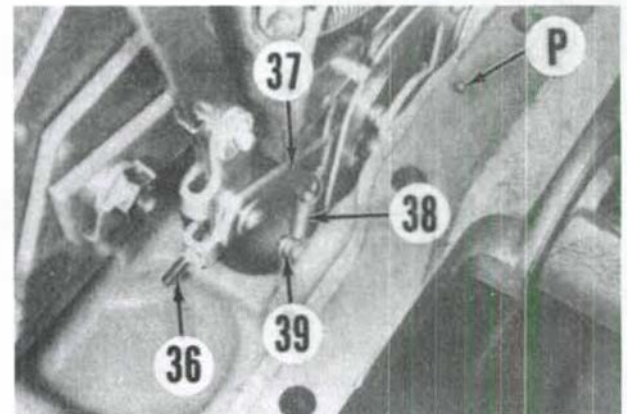

Fig. 213—Exploded view of response control side cover.

- D. Dipstick
- 4. Side cover
- 1. Control cover
- 5. Spring
- 2. Response handle
- 6. Shaft
- 3. Block
- 7. Response cam

Install control linkage as follows: Locate control cams (39 and 40—Fig. 211) in cover and start pivot shaft (P) through left-hand side of cover, but not into cams. Install vertical lever spring (41—Fig. 217) over pivot bracket (31) and around vertical lever (32), then insert pivot shaft into control cams. Do not tighten set screw at this time. Insert spring rods (34—Fig. 211) into mounting bracket (30), then remove cotter pins to release the springs. Install assembled quadrant while holding control fingers away from quadrant rollers. Install quadrant retaining pin (P—Fig. 215). Hook spring (38) between position control cam and finger (37). Install pressure control lever (50—Fig. 214) if so equipped. Adjust cam pivot shaft (P—Fig. 216) to obtain minimum linkage side play, but make sure cams move freely. Tighten set screw (S) to secure pivot shaft.

Install rockshaft (27—Fig. 210) through left-hand side of cover aligning master spline on shaft with master spline on rockshaft arm and lift arms. Tighten cap screws retaining lift arms until shaft side play is minimum, but arms can still be raised and lowered freely.

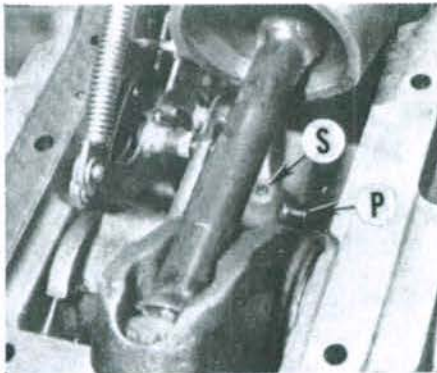

Fig. 216—Set screw (S) retains control cam pivot shaft (P).

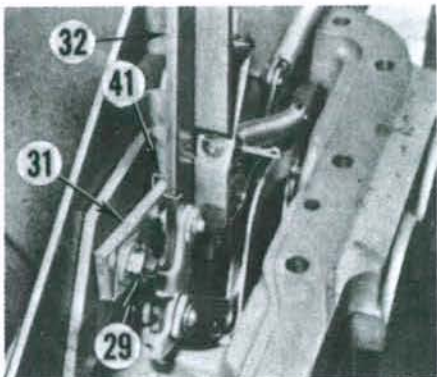

Fig. 217—View of vertical lever spring (41) installed.

29. Nut  
31. Pivot bracket

32. Vertical lever  
41. Spring

Install and adjust master control spring as outlined in paragraph 201.

Adjust internal linkage as outlined in paragraph 218 before reinstalling lift cover.

**218. INTERNAL LINKAGE ADJUSTMENT.** The following internal lift linkage adjustments must be performed before reinstalling lift cover. The following special tools are required to properly make the internal adjustments: Gage tool (MFN 1080-D), Gage tool (MFD 970) and Nuday No. 6088 and 6089 bushings.

Invert the lift cover in a fixture or on a bench. Block up the cover as necessary so rockshaft can be moved to the normal raised "TRANSPORT" position. Check and adjust master control spring (12—Fig. 209) as outlined in paragraph 201. Make certain draft control rod does not contact spring plunger (8) when adjusting master control spring.

**219. DRAFT CONTROL ROD.** To adjust draft control rod (42—Fig. 218), move draft control lever to fully "UP" position. Be sure draft control rod is contacting master control spring plunger, then adjust control rod cap screw (C) until clearance (D) between head of screw

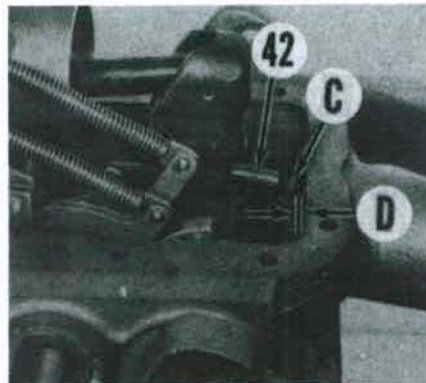

Fig. 218—Adjust draft control rod (42) so clearance (D) between capscrew (C) and lift cover casting is 5.84 mm (0.230 inch).

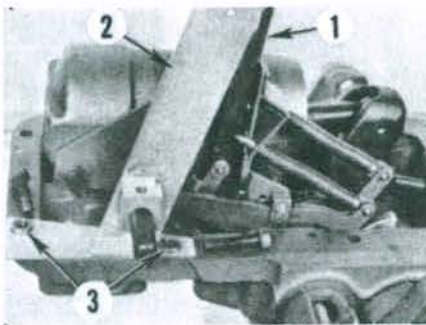

Fig. 219—The special gage tool (MFN 1080-D) shown at (2) should be installed using two Nuday No. 6088 bushings (3) and bolts. Vertical lever is shown at (1).

and lift cover casting is 5.84 mm (0.230 inch).

**220. DRAFT CONTROL LINKAGE.** To adjust draft control linkage, install special gage tool (MFN 1080-D) onto lift cover using special bushings (Nuday No. 6088) as shown in Fig. 219. Be sure vertical lever (1) is to rear of setting rod on gage tool, then slide Nuday No. 6089 bushing (B—Fig. 222) over the setting rod.

If equipped with pressure control, move pressure control lever (4—Fig. 220) upward. On all models, turn position control adjustment screw (5) outward several turns. Move position control lever against transport stop and place draft control lever between sector marks as shown in Fig. 221. Attach a suitable spring scale to vertical lever (1—Fig. 222) and apply a 1.36 Kg (3 pound) pull

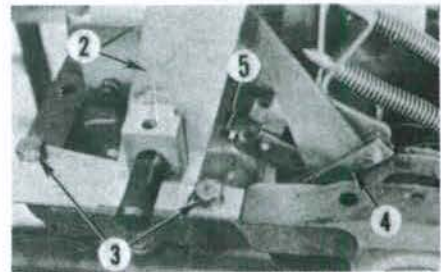

Fig. 220—Refer to text for internal adjustment of lift cover linkage.

2. Gage tool (MFN 1080-D)  
3. Bolts & Nuday 5089 bushings

4. Pressure control lever  
5. Position control adjusting screw

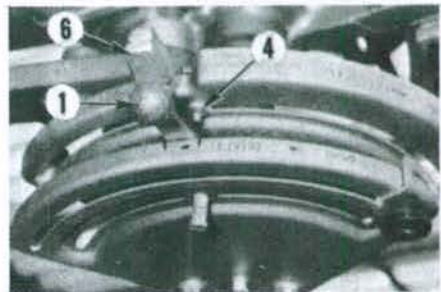

Fig. 221—View of control quadrant. Pressure control model is shown.

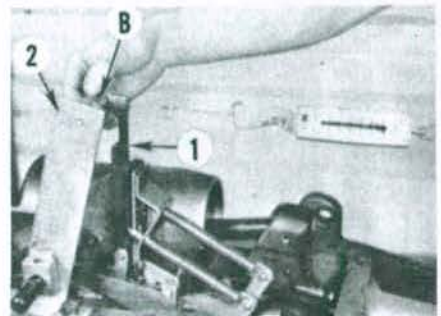

Fig. 222—Refer to text for testing and adjustment of draft control linkage.

to lever. The vertical lever should make light contact with bushing (B).

If adjustment is incorrect, loosen pivot bracket nut (7—Fig. 223) just enough to allow pivot bracket to be moved. While applying 1.36 Kg (3 pound) pull to vertical lever, move pivot assembly with a screwdriver as shown in Fig. 224 until vertical lever lightly contacts bushing (B). Tighten nut to secure pivot bracket. Recheck adjustment after nut is tightened.

**221. POSITION CONTROL LINKAGE.** To adjust position control linkage, first move draft control lever to fully "UP" position on quadrant and place position control lever against transport stop. Position gage tool (MFN 970) with side marked .636 between rockshaft arm and lift cover casting as shown at (T—Fig. 225). Using a spring scale, apply 1.36 Kg (3 pounds) pull to vertical lever (1). The vertical lever should lightly contact bushing (B).

If adjustment is incorrect, turn position control adjusting screw (5) as necessary until vertical lever makes light contact with bushing while applying 1.36 Kg (3 pounds) pull to lever. Move position control lever to "CONSTANT PUMPING" position then back

to "TRANSPORT" position (past transport stop) and recheck adjustment. Remove special gage tools when adjustments are correct.

**222. PRESSURE ADJUSTMENT.** This is an initial setting only, final adjustment is accomplished after lift cover is installed. Refer to installed adjustments outlined in paragraph 203.

On models without pressure control, thread adjusting screw (Fig. 226) into block (2) until an equal amount of threads (E) are above and below the block. Note that it will not be necessary to move the adjusting screw if system pressure was satisfactory prior to disassembly and screw setting has not been disturbed.

On Models with pressure control, be sure pressure control lever (1—Fig. 227) is correctly installed on pivot pin (2) and rests against quadrant cam.

**MAIN HYDRAULIC PUMP**

**Models Without Pump Mounted Servo Valve**

**223. REMOVE AND REINSTALL.** To remove the hydraulic system pump on models not equipped with auxiliary pump, first drain system and remove lift cover as outlined in paragraph 207. Col-

lapse and remove the drive shaft coupler and remove pto output shaft. Remove the dowel pin (P—Fig. 228) from each side of rear axle center housing, then lift hydraulic pump out through top opening.

On models equipped with ipto, Multi-Power and/or auxiliary hydraulics, drain the system and remove hydraulic lift cover as outlined in paragraph 207. Remove transmission top cover. Remove step plates and disconnect brake rods. Disconnect Multi-Power pressure line (if so equipped). Support transmission and differential housing separately, remove flange bolts and separate tractor at rear of transmission housing. Disconnect and remove auxiliary pump hydraulic lines leading to side cover and ipto clutch valve on models so equipped. Remove pump mounting dowel (P—Fig. 228)

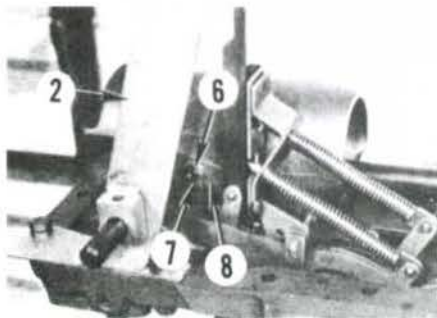

Fig. 223—Refer to text for changing the position of pivot assembly.

- 2. Gage tool (MFN 1080-D)
- 6. Locking clip
- 7. Nut
- 8. Pivot bracket

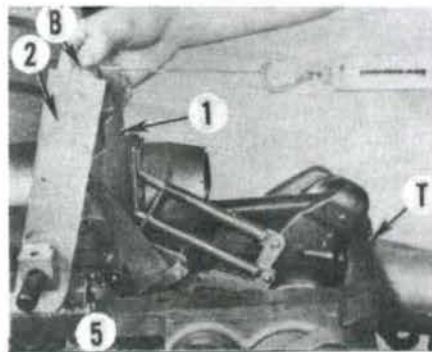

Fig. 225—View showing test using spring scale, MFN 1080-D gage tool (2) and MFN 970 gage block (T). Refer to text.

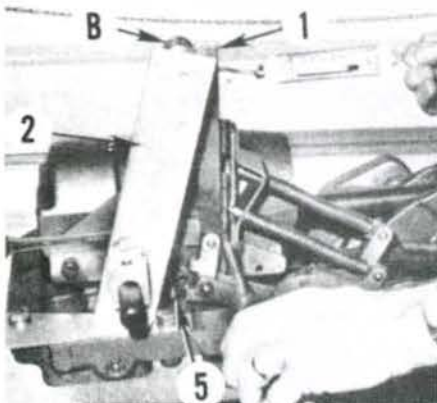

Fig. 224—Use a screwdriver to move pivot bracket while checking for correct setting. Refer to text.

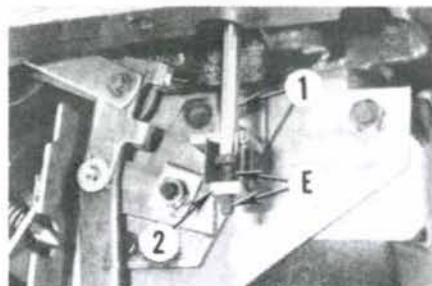

Fig. 226—On models without pressure control, initial setting of pressure adjusting screw is with equal amounts of threads (E) on both sides of adjusting block (2). Screwdriver is shown at (1).

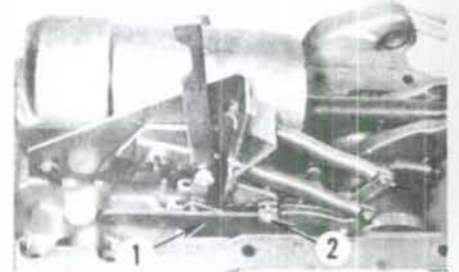

Fig. 227—View of pressure control lever (1) and pivot pin (2) used on models equipped with pressure control.

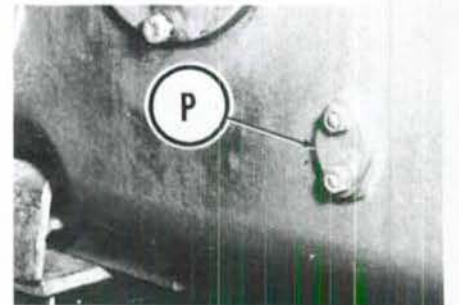

Fig. 228—Hydraulic pump positioning dowel pins (P) are located on each side of differential housing.

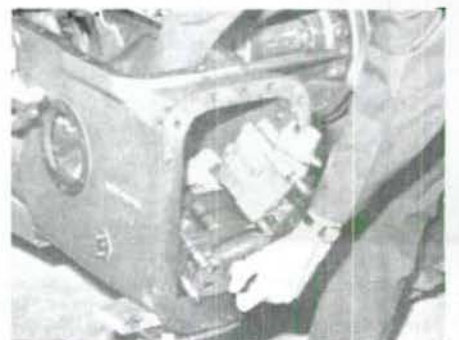

Fig. 229—Pump and drive assembly must be removed out front of differential housing on models equipped with an auxiliary pump.

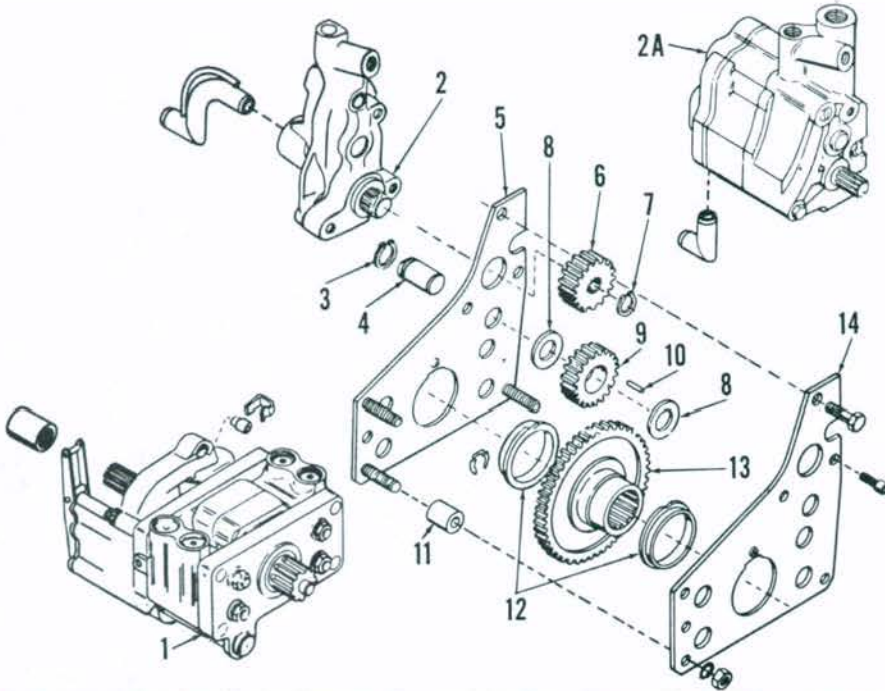

Fig. 230—Exploded view of hydraulic pump drive gear train. Pump (2) is used for Multi-Power transmission alone and pump (2A) is used when equipped with both Multi-Power and auxiliary hydraulics.

- |                        |                     |                   |                |
|------------------------|---------------------|-------------------|----------------|
| 1. Main hydraulic pump | 5. Mounting bracket | 8. Thrust washer  | 11. Spacer     |
| 2. Auxiliary pump      | 6. Pump gear        | 9. Idler gear     | 12. Bushing    |
| 3. Snap ring           | 7. Snap ring        | 10. Needle roller | 13. Drive gear |
| 4. Idler shaft         |                     |                   | 14. Bracket    |

from each side of differential housing, then pump package forward through front opening of rear axle center housing.

**NOTE:** On some models with auxiliary hydraulic system, it is necessary to reposition pump and remove elbow from top of pump before pump assembly can be withdrawn (Fig. 229).

The gear train mounting plates serve as pump support. Refer to Fig. 230. Gear train must be disassembled to remove pump. Idler gear (9) contains 22 loose needle bearings (10). Gear backlash is not adjustable; renew parts concerned if backlash exceeds 0.38 mm (0.015 inch) between any two gears. Tighten retaining bolts to a torque of 41.47 N·m (30.35 ft.-lbs.).

**224. OVERHAUL.** To disassemble the removed hydraulic pump, disconnect the control lever pivot pin and remove control lever (1—Fig. 231) from valve rollers (33). Remove rollers and pin (32). Remove filter (6) and housing (5) from intake housing (4). Disconnect oscillator (23) from cam follower (17). Remove cap nut (19). Remove stud nuts, then

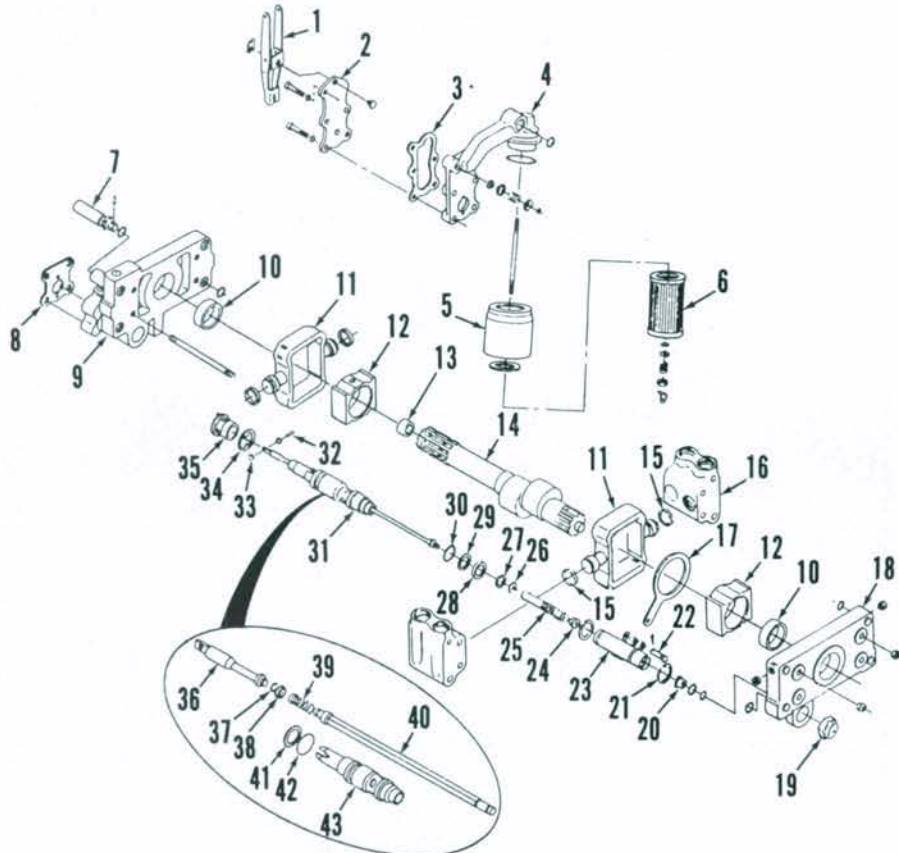

Fig. 231—Exploded view of hydraulic lift pump assembly. Safety relief valve (7) is used on models not equipped with pressure control valve.

- |                    |                        |                    |                        |                    |                        |                          |
|--------------------|------------------------|--------------------|------------------------|--------------------|------------------------|--------------------------|
| 1. Valve lever     | 7. Safety relief valve | 13. Bearing        | 19. Cap nut            | 25. Spring         | 31. Control valve body | 37. Snap ring            |
| 2. Rear cover      | 8. Gasket              | 14. Camshaft       | 20. Collar             | 26. Retainer       | 32. Pin                | 38. Washer               |
| 3. Gasket          | 9. Rear body           | 15. Piston rings   | 21. Snap ring          | 27. Snap ring      | 33. Roller             | 39. Spring               |
| 4. Intake manifold | 10. Bushings           | 16. Valve chambers | 22. Pin                | 28. Sleeve washer  | 34. Lockplate          | 40. Oscillator rod       |
| 5. Filter housing  | 11. Piston yokes       | 17. Cam follower   | 23. Oscillator housing | 29. Back-up washer | 35. Spacer             | 41. Washer               |
| 6. Filter element  | 12. Cam blocks         | 18. Front body     | 24. Guide              | 30. "O" ring       | 36. Actuating rod      | 42. "O" ring             |
|                    |                        |                    |                        |                    |                        | 43. Valve & sleeve assy. |

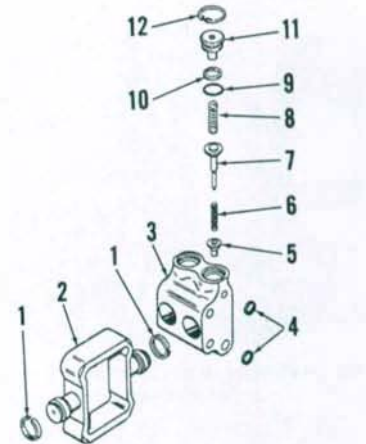

Fig. 232—Exploded view of valve chamber and associated parts showing poppet type inlet and outlet valves.

- |                |                  |
|----------------|------------------|
| 1. Piston ring | 7. Outlet valve  |
| 2. Piston      | 8. Spring        |
| 3. Chamber     | 9. "O" ring      |
| 4. "O" rings   | 10. Back-up ring |
| 5. Inlet valve | 11. Plug         |
| 6. Spring      | 12. Snap ring    |

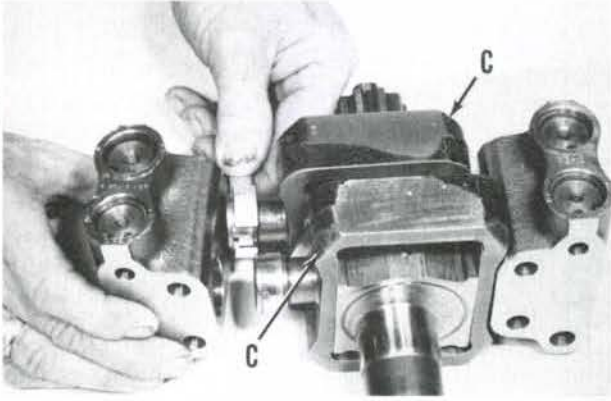

Fig. 233—Use a suitable ring compressor to compress piston rings when installing valve chambers. Be sure chamfered corners (C) of piston yokes face away from each other.

separate front body (18) from rear body (9). Withdraw control spool and oscillator (23) as a unit. Remove snap ring at front of spool and separate spool assembly from oscillator housing. Compress actuating rod (36), remove snap ring (37) and separate actuating rod, spring (39) and oscillator rod (40) from spool if desired. Push control valve sleeve (43) from pump body.

Slide camshaft (14) with piston yokes (11) and valve chambers (16) from rear body (9). Remove intake housing (4) and cover plate (2). Separate cam blocks (12),

piston yokes (11), valve chambers (16), cam follower (17) and camshaft (14).

To disassemble valve chambers, first remove snap ring (12—Fig. 232). Thread a ¼ inch UNC bolt into tapped hole at top of plug (11), then pull plug from chamber. Remove poppet valves and springs from chamber bore.

Inspect all parts and renew if excessively worn or damaged. The control valve spool and sleeve (31—Fig. 231) are serviced as a matched assembly. When renewing bushings (10) be sure end of bushing does not extend above machined surface of pump body and split in bushing is located at the top of body. Always renew all gaskets and “O” rings when reassembling.

To reassemble, reverse the disassembly procedure while noting the following special instructions: Use a suitable ring compressor when installing valve chambers onto pistons as shown in Fig. 233. Be sure chamfered corners (C) of

piston yokes face away from each other. Be sure cam block (2—Fig. 234) with shoulder (S) is over widest (front) cam lobe and shoulder faces inward as shown. Be sure cam follower (3) is towards bottom of pump. Notches (N—Fig. 235) in end of valve sleeve must be aligned horizontally in valve bore and pins (P) in spacer (2) must be vertical to pump body. Lockplate (1) fits into notches of sleeve and spacer. Tighten pump body stud nuts to 41-47 N·m (30-35 ft.-lbs.) torque. Be sure camshaft rotates freely.

MAIN HYDRAULIC PUMP

Models With Pump Mounted Servo Valve

225. REMOVE AND REINSTALL.

To remove the main hydraulic pump on models not equipped with ipto, Multi-Power and/or auxiliary hydraulics, first drain hydraulic oil. Remove lift cover as outlined in paragraph 216. Remove the adjusting block and upper tube and spring from servo valve (10—Fig. 237). Collapse and remove the drive shaft coupler and remove pto output shaft. Remove dowel pins (P—Fig. 228) from each side of differential housing, then lift hydraulic pump out through top opening of housing.

On models equipped with ipto, Multi-Power and/or auxiliary hydraulics, tractor must be split between differential housing and transmission. Drain oil from system and remove lift cover as outlined in paragraph 216. Remove step plates and disconnect brake rods and electrical wiring as necessary. Discon-

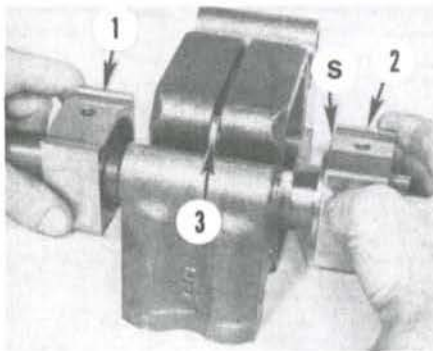

Fig. 234—Be sure that cam block (2) with shoulder (S) is over widest (front) cam lobe and shoulder faces inward. Cam follower (3) goes towards bottom of pump.

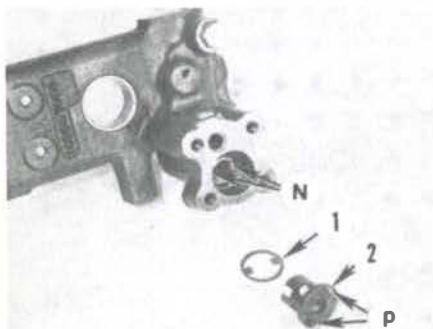
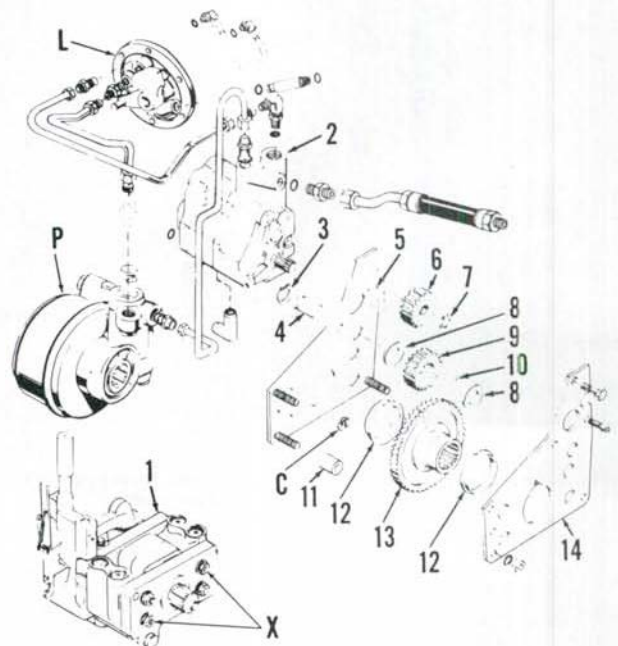

Fig. 235—Notches (N) in valve sleeve must be positioned horizontally in valve body and pins (P) in spacer (2) must be vertical to pump.

Fig. 236—Exploded view of auxiliary pump drive gear train and associated parts.

- L. Left side cover
- P. Ipto clutch & valve
- 1. Main hydraulic pump
- 2. Auxiliary pump
- 3. Snap ring
- 4. Idler shaft
- 5. Mounting bracket
- 6. Pump gear
- 7. Snap ring
- 8. Thrust washer
- 9. Idler gear
- 10. Needle roller
- 11. Spacer
- 12. Bushing
- 13. Drive gear
- 14. Bracket



nect pressure line at Multi-Power/ipto pump if so equipped. Support transmission housing and differential separately, remove retaining bolts and separate rear of tractor from transmission housing. Remove pump mounting dowels (P—Fig. 228) from each side of differential housing. Disconnect hydraulic pipes from the pumps and remove tube and spring from pump servo valve (10—Fig. 237). Slide pump assembly forward through front opening of differential housing.

The gear train mounting plates (5 and 14—Fig. 236) serve as pump support. Idler gear (9) contains 22 loose needle bearings (10). Gear backlash is not adjustable; renew parts as necessary if backlash exceeds 0.38 mm (0.015 inch) between any two gears.

To reinstall pump assembly, reverse the removal procedure.

**226. OVERHAUL.** To disassemble the removed hydraulic pump, first separate the auxiliary pump and drive train from main pump. Turn pressure

control adjusting screw (1—Fig. 238) out of pivot lever (2) until end of bolt is flush with inside of lever. Remove adjusting block (13), tube (14) and spring (15) from servo valve if not removed previously. Unhook diaphragm lever link (4) from control valve, remove valve mounting stud nut, and remove servo valve from top of pump.

Remove clip retaining control lever (1—Fig. 237), then slide control lever from control valve (28). Remove rollers and pin from end of control valve actuating rod. Remove filter assembly and intake housing (5) from pump.

Remove retainer clip and cap (24) from front of oscillator drive. Remove pin retaining oscillator (25) to cam follower (20). Remove nuts attaching pump bodies together, then carefully remove front body (22). Withdraw control valve and oscillator as a unit from pump. Carefully slide piston yokes (14), valve chambers (19), cam blocks (16 and 21) and camshaft (18) away from rear body (11). Pull valve spool sleeve from rear body.

Disassemble the removed assemblies as outlined in the appropriate following paragraphs.

**227. SERVO VALVE.** Refer to Fig. 238 for exploded view of servo valve. Unbolt and remove diaphragm cover (9). Use an Allen wrench to remove orifice plug (12). Thread a suitable screw into retainer plug (29) and remove retainer, spring (28), discs (27) and secondary relief valve (26). Remove guide (16) and spring support (17), then bump housing to remove plunger (20) and ball (20A). Use hooked wire to pull plunger guide (19) from bore then use needlenose pliers to pull ball valve seat (21) from bore.

Inspect all parts for wear or damage and renew as necessary.

Diameter of large end of plunger (20) should be 5.530-5.542 mm (0.2177-0.2182 inch), and diameter of tapered end of plunger should be 5.080-5.232 mm (0.200-0.206 inch). Bore of plunger guide (19) should be 5.644-5.669 mm (0.2222-

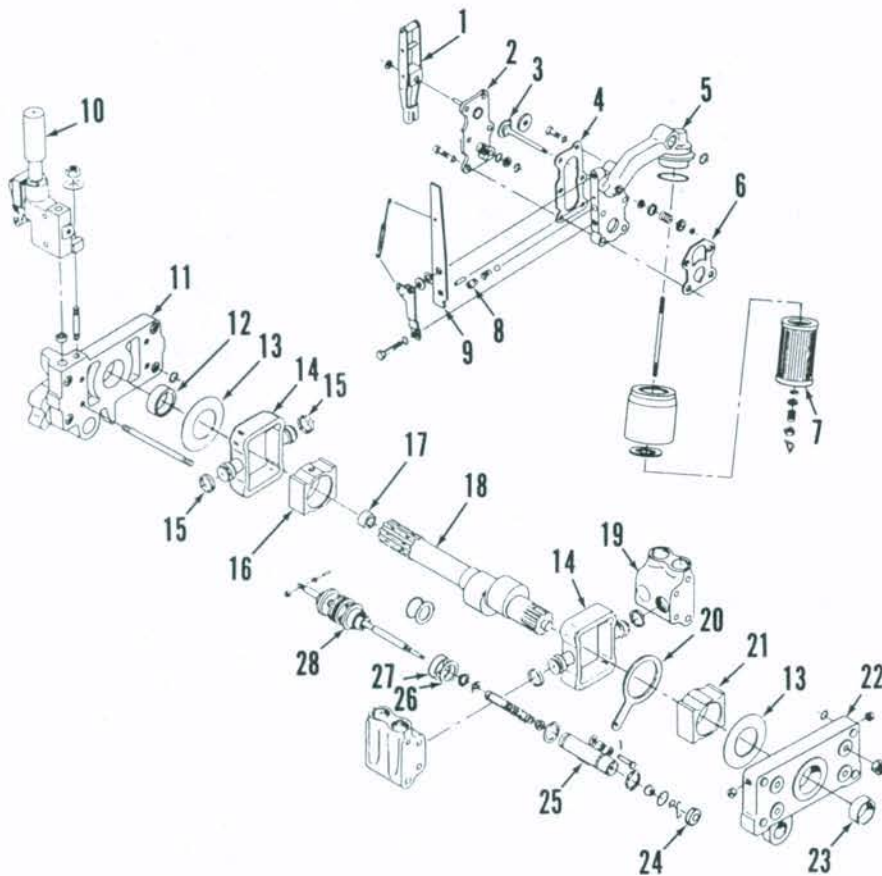

Fig. 237—Exploded view of main hydraulic pump. Thrust washers (13) are not used on early production pumps.

- |                     |                           |                                     |                         |
|---------------------|---------------------------|-------------------------------------|-------------------------|
| 1. Control lever    | 9. Response control lever | 15. Piston rings                    | 21. Cam block           |
| 2. Rear cover plate | 10. Servo valve assy.     | 16. Cam block                       | 22. Front body          |
| 3. Nonreturn valve  | 11. Rear body             | 17. Needle bearing                  | 23. Bushing             |
| 4. Gasket           | 12. Bushing               | 18. Camshaft                        | 24. Nut                 |
| 5. Intake housing   | 13. Thrust washers        | 19. Valve chamber                   | 25. Oscillator assy.    |
| 6. Gasket           | 14. Piston yokes          | 20. Oscillator drive (cam follower) | 26. Washer              |
| 7. Filter element   |                           |                                     | 27. Spacer              |
| 8. Orifice bushing  |                           |                                     | 28. Control valve assy. |

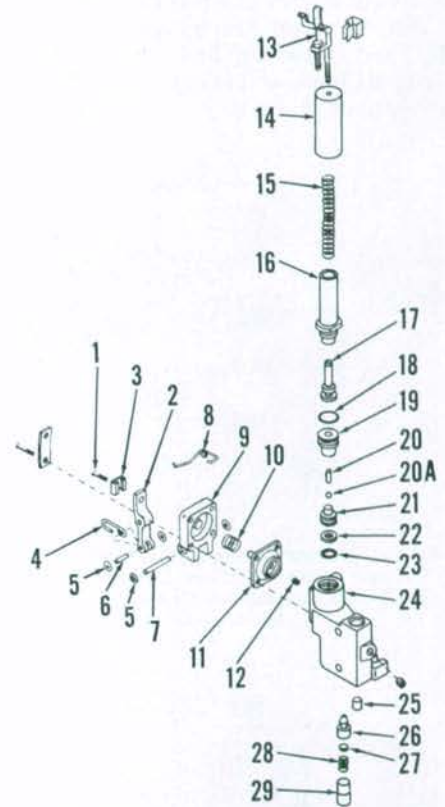

Fig. 238—Exploded view of servo valve assembly.

- |                    |                   |
|--------------------|-------------------|
| 1. Adjusting screw | 16. Guide         |
| 2. Lever           | 17. Support       |
| 3. Clip            | 18. "O" ring      |
| 4. Link            | 19. Plunger guide |
| 5. Clip            | 20. Plunger       |
| 6. Pin             | 20A. Ball         |
| 7. Pin             | 21. Seat          |
| 8. Spring          | 22. Washer        |
| 9. Diaphragm cover | 23. "O" ring      |
| 10. Spring         | 24. Body          |
| 11. Diaphragm      | 25. Dowel         |
| 12. Orifice plug   | 26. Valve         |
| 13. Block assy.    | 27. Disc          |
| 14. Head           | 28. Spring        |
| 15. Spring         | 29. Retainer      |

0.2232 inch). Maximum diameter of seat in ball valve is 4.32 mm (0.170 inch).

All "O" rings should be soaked approximately one hour in hydraulic oil before assembling. Install new back-up washer (22) and "O" ring (23) on ball valve seat (21), then install in bore of housing. Install new "O" ring (18) on plunger guide (19), then insert plunger guide into bore with cross drilled hole toward ball valve seat. Insert ball (20A) into bore and make sure it enters bore of guide (19). Install plunger (20) with tapered (small) end toward ball. Install spring support (17) with large flat end against plunger guide (19). Apply two or three drops of Loctite 242 on threads of spring guide (16), then install and tighten to 20-40 N·m (15-30 ft.-lbs.) torque. Insert sec-

ondary relief valve (26), discs (27), if so equipped, spring (28) and retainer (29) into bore in bottom of housing. The retainer is a light press fit and should be installed flush with mounting surface of valve body (24). Install orifice plug (12), diaphragm (11), spring (10), cover (9), lever (2) and related parts.

**228. CONTROL VALVE.** The control valve is serviced as a matched assembly which consists of rod (12—Fig. 239) and all parts (21 through 32).

To disassemble the valve and oscillator assembly, unseat and remove retaining ring (16) from internal groove in oscillator housing (7) and withdraw valve from oscillator unit. Remove retaining ring (8) while compressing

spring (11). Push rod (12) in and remove snap ring (21), then withdraw remaining parts.

Assemble by reversing disassembly procedure. End of valve spool (24) with narrow slot should be toward oscillator rod (32); end with larger slots should be toward actuating rod (12). Install sleeve (25) in rear body bore so roll pin (23) is down near bottom.

**229. VALVE CHAMBERS.** Both valve chambers (19—Fig. 237) are identical and interchangeable, and each contains two sets of valve components (5 through 12—Fig. 240). To disassemble the chamber, remove snap ring (12) and thread a ¼ inch UNC bolt into plug (11) to provide leverage. Plug can be pulled by hand. A reseating reamer (Tool No. N-6007A) is available which dresses both seats in one bore at the same time. If tool is used, remove only enough metal to smooth the seats. All parts are available individually.

When installing, do not compress retainer plug (11) deeper than 5.8 mm (0.23 inch) from top of plug to top of valve chamber. Be sure to pull plug up against snap ring (12) after snap ring is seated.

**230. INTAKE HOUSING.** The response control valve and nonreturn valve are contained in the intake housing (5—Fig. 237). Refer to Fig. 241 for an exploded view of intake housing and related parts.

When reassembling, be sure "O" ring (9), washer (8) and retaining ring (7) are correctly installed on cover plate (39). Install ring (11) on nonreturn valve (10),

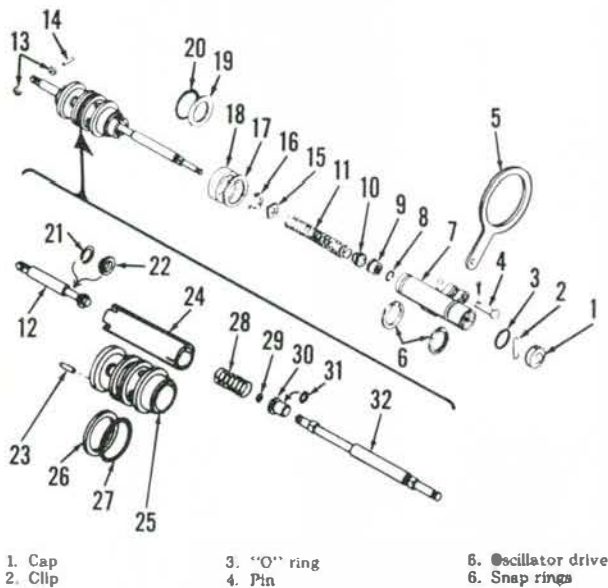

Fig. 239—Exploded view of hydraulic pump control valve and camshaft driven oscillator assembly.

- 7. Oscillator
- 8. Snap ring
- 9. Collar
- 10. Guide
- 11. Spring
- 12. Rod
- 13. Rollers
- 14. Pin
- 15. Disc
- 16. Snap ring
- 17. Washer
- 18. Spacer
- 19. Washer
- 20. "O" ring
- 21. Snap ring
- 22. Washer
- 23. Pin
- 24. Valve spool
- 25. Valve sleeve
- 26. Washer
- 27. "O" ring
- 28. Spring
- 29. Snap ring
- 30. Collar
- 31. "O" ring
- 32. Rod

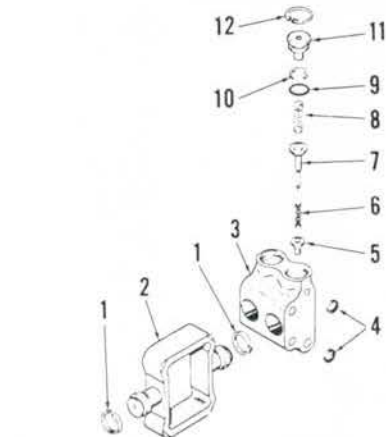
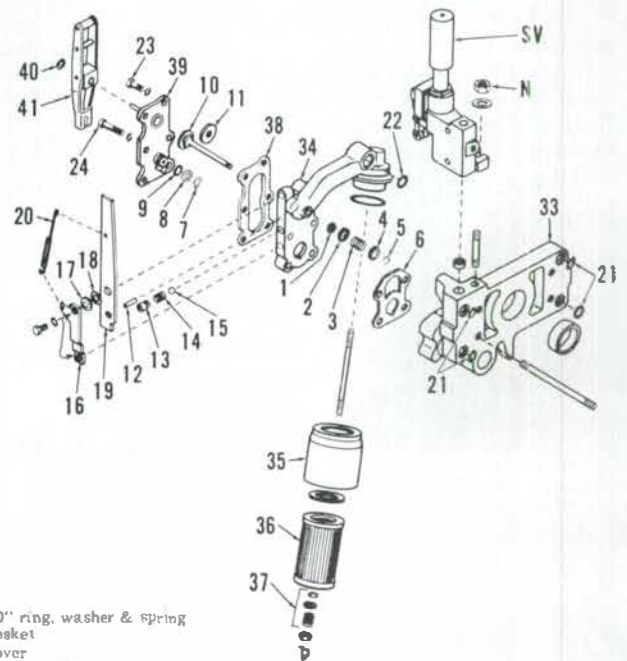

Fig. 240—Exploded view of valve chamber and associated parts.

- 1. Piston ring
- 2. Piston
- 3. Chamber
- 4. "O" rings
- 5. Inlet valve
- 6. Spring
- 7. Outlet valve
- 8. Spring
- 9. "O" ring
- 10. Back-up ring
- 11. Plug
- 12. Snap ring

Fig. 241—Exploded view of intake housing and related parts. Servo valve (SV) is attached to rear body (33) by nut (N).

- 1. Seal
- 2. Retainer
- 3. Spring
- 4. Cap
- 5. Snap ring
- 6. Gasket
- 7. Snap ring
- 8. Washer
- 9. "O" ring
- 10. Valve
- 11. Ring
- 12. Pin
- 13. Bushing
- 14. Spring
- 15. Ball
- 16. Retainer
- 17. Bushing
- 18. Washer
- 19. Lever
- 20. Spring
- 21. "O" rings
- 22. "O" rings
- 23. Screws
- 24. Screws
- 25. Rear body
- 26. Intake housing
- 27. Filter housing
- 28. Filter
- 29. "O" ring, washer & spring
- 30. Gasket
- 31. Cover
- 32. Retainer clip
- 33. Lever assy.





then insert valve through bore in housing. Install seal (1) over valve stem followed by retainer (2), spring (3), cap (4) and "E" ring (5). Install cover plate (39) and gasket (38) onto intake housing.

Position intake housing onto rear body making sure roll pin in valve sleeve engages slot in intake housing. Tighten the retaining cap screws to 20-27 N · m (15-20 ft.-lbs.) torque.

**231. ASSEMBLY.** Assemble valve chambers (19—Fig. 242) onto piston yokes (14) making sure chamfered corners (C) of yokes face away from each other. Install camshaft, cam follower and cam blocks into piston yokes making sure cam block with shoulder is at front (widest lobe) of camshaft and that shoulder faces inward. Slide camshaft assembly into rear body making sure end of cam follower (20—Fig. 237) is towards bottom of pump.

Install control valve assembly (28) into rear body, then position front body over camshaft and studs. Tighten stud nuts evenly to 41-47 N · m (30-35 ft.-lbs.) torque. Make sure camshaft and pistons move freely. Install cap (24) and retaining ring on end of oscillator housing. Connect cam follower to oscillator.

**AUXILIARY PUMP**

**All Models So Equipped**

**232.** Two different auxiliary pumps have been used. Pump shown in Fig. 243 is used on tractors equipped only with Multi-Power transmission and/or independent pto. Dual section pump shown in Fig. 244 is used for auxiliary hydraulic applications as well as for Multi-Power or independent pto pressure.

On all models, the auxiliary pump is located directly above the main hydraulic pump within the differential housing. The auxiliary pump is removed with the main hydraulic pump as a unit.

Refer to appropriate paragraph 223 or 225 for removal procedure.

**233. SINGLE PUMP.** To disassemble the removed pump, first remove snap ring retaining drive gear to pump shaft. Remove cap screws securing pump to gear train mounting plate, then remove pump. Remove cap screws attaching end cover (1—Fig. 243) to body (8) and separate pump components.

Inspect all parts for wear or damage. All parts except pump body are available for renewal. Pump gears (5 and 6) must be renewed as a matched set.

To reassemble, reverse the disassembly procedure. Be sure relieved edge of pressure plate (3) is towards outlet side of pump and smooth side is away from gears. Tighten cover retaining cap screws evenly to 27 N · m (20 ft.-lbs.) torque.

Safety relief valve is set to open at 4480-5170 kPa (750-850 psi). If valve requires servicing, adjust pressure setting as follows: Turn adjusting screw (12) in

until it bottoms, then turn screw out 1-1/2 turns. Attach a hand pump with pressure gage to pump outlet port and check valve opening pressure. Turn adjusting screw as necessary, then stake the screw when correct pressure is obtained.

**234. DUAL PUMP.** It is recommended that auxiliary hydraulic system pressure be checked prior to servicing the hydraulic pump. The pressure can be checked at an auxiliary valve outlet using suitable pressure gage and fittings. System pressure should be between 15860-17925 kPa (2300-2600 psi). Hydraulic lift cover must be removed for access to the adjustable high pressure relief valve which is located in pump rear cover plate (23—Fig. 244).

To disassemble the removed pump, first remove snap ring retaining drive gear to pump shaft. Remove cap screws attaching pump to gear train mounting plate and remove pump from rear plate. Scribe a line across pump bodies and end cover to ensure correct alignment when reassembling. Remove tie bolts attaching pump bodies to end cover, then

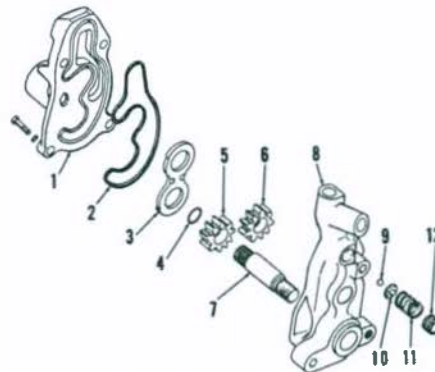

Fig. 243—Exploded view of single section auxiliary pump used on some models.

- |                   |                      |
|-------------------|----------------------|
| 1. End cover      | 7. Driveshaft        |
| 2. Seal ring      | 8. Pump              |
| 3. Pressure plate | 9. Relief valve ball |
| 4. Snap ring      | 10. Guide plate      |
| 5. Drive gear     | 11. Spring           |
| 6. Driven gear    | 12. Adjusting plug   |

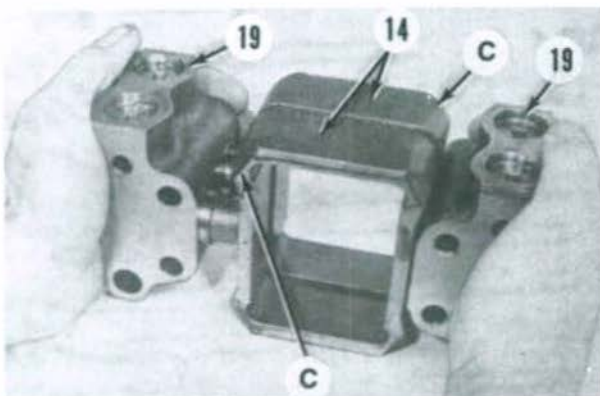

Fig. 242—Chamfered corners (C) of piston yokes (14) must face away from each other.

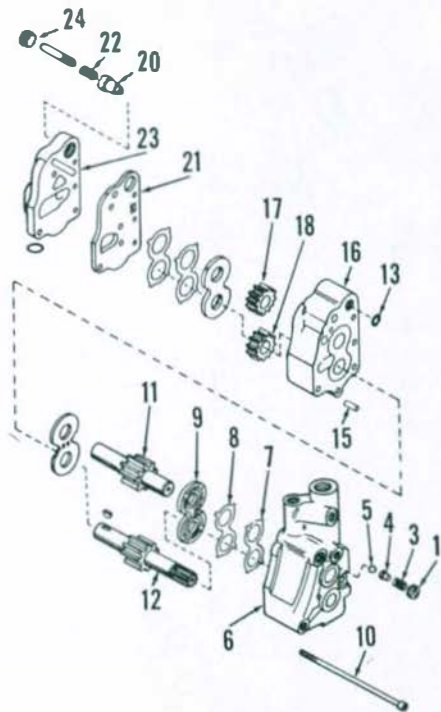

Fig. 244—Exploded view of dual section auxiliary pump showing component parts.

- |                                  |                                     |
|----------------------------------|-------------------------------------|
| 1. Adjusting plug (low pressure) | 13. "O" ring                        |
| 3. Spring                        | 15. Dowel                           |
| 4. Poppet                        | 16. Rear body                       |
| 5. Ball                          | 17. Driven gear                     |
| 6. Front body                    | 18. Drive gear                      |
| 7. Back-up gasket                | 20. Piston                          |
| 8. Seal                          | 21. Plate                           |
| 9. Pressure plate                | 22. Spring                          |
| 10. Socket head screw            | 23. End cover                       |
| 11. Driven gear                  | 24. Adjusting screw (high pressure) |
| 12. Drive gear                   |                                     |

separate pump components as shown in Fig. 244. Use care to avoid damaging machined mating surfaces and gear pockets of pump bodies. Do not remove high pressure adjusting screw (24); screw is staked in place and setting should not be changed.

Check all parts for evidence of wear or damage and renew as necessary. If pump housings show evidence of wear or scoring in gear pocket area, complete pump must be renewed.

To reassemble, reverse the disassembly procedure while noting the following special instructions: Be sure pressure seal (8) is installed into wear plates (9) first, then install back-up gasket (7). Seal side of wear plates must face away from gear faces. Omit high pressure relief valve spring (22) when assembling pump bodies, and use tie bolts to draw bodies together over dowel pins. Then, remove tie bolts and separate end cover (23) from spacer plate (21). Install retaining washer and high pressure spring (22), position end cover on pump and tighten retaining screws and nut to 27 N · m (20 ft.lbs.) torque.

If low pressure relief valve (items 1 through 5) was removed from pump body, tighten adjusting screw (1) until spring is bottomed, then back screw out four turns. This should set relief valve opening pressure within specified range of 4480-5515 kPa (650-850 psi). A suitable hand pump with pressure gage can be connected to Multi-Power circuit outlet port to check opening pressure if desired.

High pressure relief valve adjusting screw (24) should not have been turned during disassembly. However, if parts of relief valve were renewed, it will be necessary to readjust valve setting after pump is reinstalled. Hydraulic lift cover must be removed to gain access to relief valve adjusting screw. Maximum system pressure should be 15860-17925 kPa (2300-2600 psi).

**AUXILIARY VALVE**

**All Models Except MF250**

**235. OVERHAUL.** To disassemble valve, remove snap ring (16—Fig. 245) and end plug (15). Loosen detent assembly (2) adjusting screws, then unbolt and remove end cap (1) from valve body. Withdraw spool assembly from spring end of valve body.

**NOTE:** Valve spools are selective fitted to their body bores and must not be interchanged. When servicing dual spool valve, identify spools as they are removed to ensure correct reassembly.

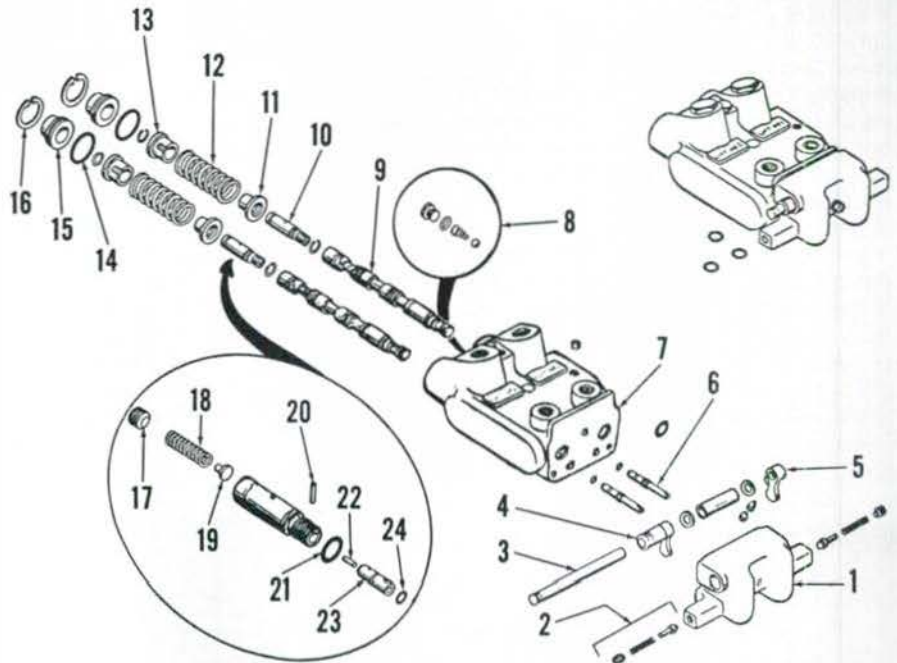
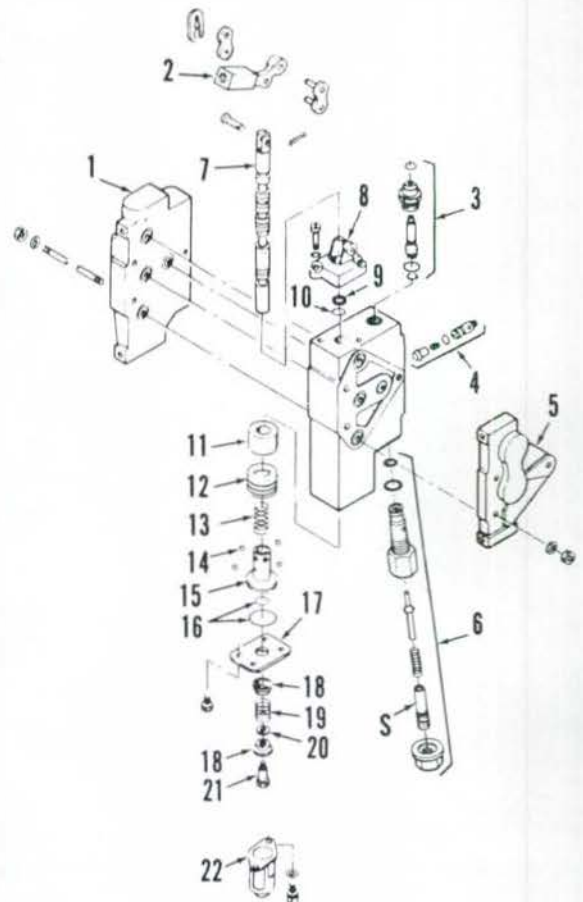

Fig. 245—Exploded view of dual spool auxiliary valve assembly used on some models.

- |                 |                     |                 |              |
|-----------------|---------------------|-----------------|--------------|
| 1. End cap      | 7. Body             | 13. Sleeve      | 19. Guide    |
| 2. Detent assy. | 8. Check valve      | 14. "O" ring    | 20. Pin      |
| 3. Inner rod    | 9. Spool            | 15. Plug        | 21. "O" ring |
| 4. Outer lever  | 10. Regulator assy. | 16. Snap ring   | 22. Pin      |
| 5. Inner lever  | 11. Sleeve          | 17. Nylon screw | 23. Guide    |
| 6. Switch valve | 12. Spring          | 18. Spring      | 24. "O" ring |

Fig. 246—Exploded view of auxiliary valve assembly used on Model MF250. Detent piston (12) is not used on early production valves.

- |   |
|---|
| S. Adjusting screw                      |
| 1. Inlet cover                          |
| 2. Control lever pivot                  |
| 3. Single/double acting converter valve |
| 4. Check valve                          |
| 5. Outlet cover                         |
| 6. Detent relief valve                  |
| 7. Valve spool                          |
| 8. Pivot bracket                        |
| 9. Wiper seal                           |
| 10. "O" ring                            |
| 11. Cage                                |
| 12. Piston                              |
| 13. Spring                              |
| 14. Detent balls                        |
| 15. Carrier                             |
| 16. "O" rings                           |
| 17. End plate                           |
| 18. Spring seats                        |
| 19. Centering spring                    |
| 20. Spacer                              |
| 21. Retaining screw                     |
| 22. End cap                             |



Remove retaining ring, centering spring (12) and spring seats from end of spool. Remove screw (17), spring (18), poppet (19) and pin (22) or ball from regulator barrel (10). Unscrew regulator barrel from spool, then remove roll pin (20) and guide (23) from regulator barrel. Remove switch valve (6) and check valve (8) from valve body.

Inspect all parts for wear, scoring or other damage and renew if necessary. Valve spools and body are available only as a complete valve assembly. Be sure to renew all "O" rings.

To reassemble valve, reverse the disassembly procedure. Adjust spool de-

tent and "kick out" pressure setting as outlined in the following paragraph.

**236. ADJUSTMENT.** Connect a suitable flow meter to rear couplers. Operate engine at 1000 rpm and place auxiliary valve control handle in "lift" position. Tighten detent adjusting screw (2—Fig. 245) until handle remains in "lift" position. Slowly close flow meter restrictor valve and note pressure at which control handle kicks out of detent and returns to neutral. Handle should kick out of detent when pressure is between 13100-14480 kPa (1900-2100 psi).

If handle kicks out before pressure reaches 13100 kPa (1900 psi), shut off engine and operate control valve handle to relieve any trapped pressure. Remove snap ring (16) and end plug (15), then turn regulator valve adjusting screw (17) inward to increase kick out pressure.

**NOTE:** Several attempts at adjustment may be necessary before desired kick out pressure is obtained. Be sure to shut off engine and relieve system pressure before removing end plug from valve.

If handle does not kick out of detent when pressure is between 13100-14480

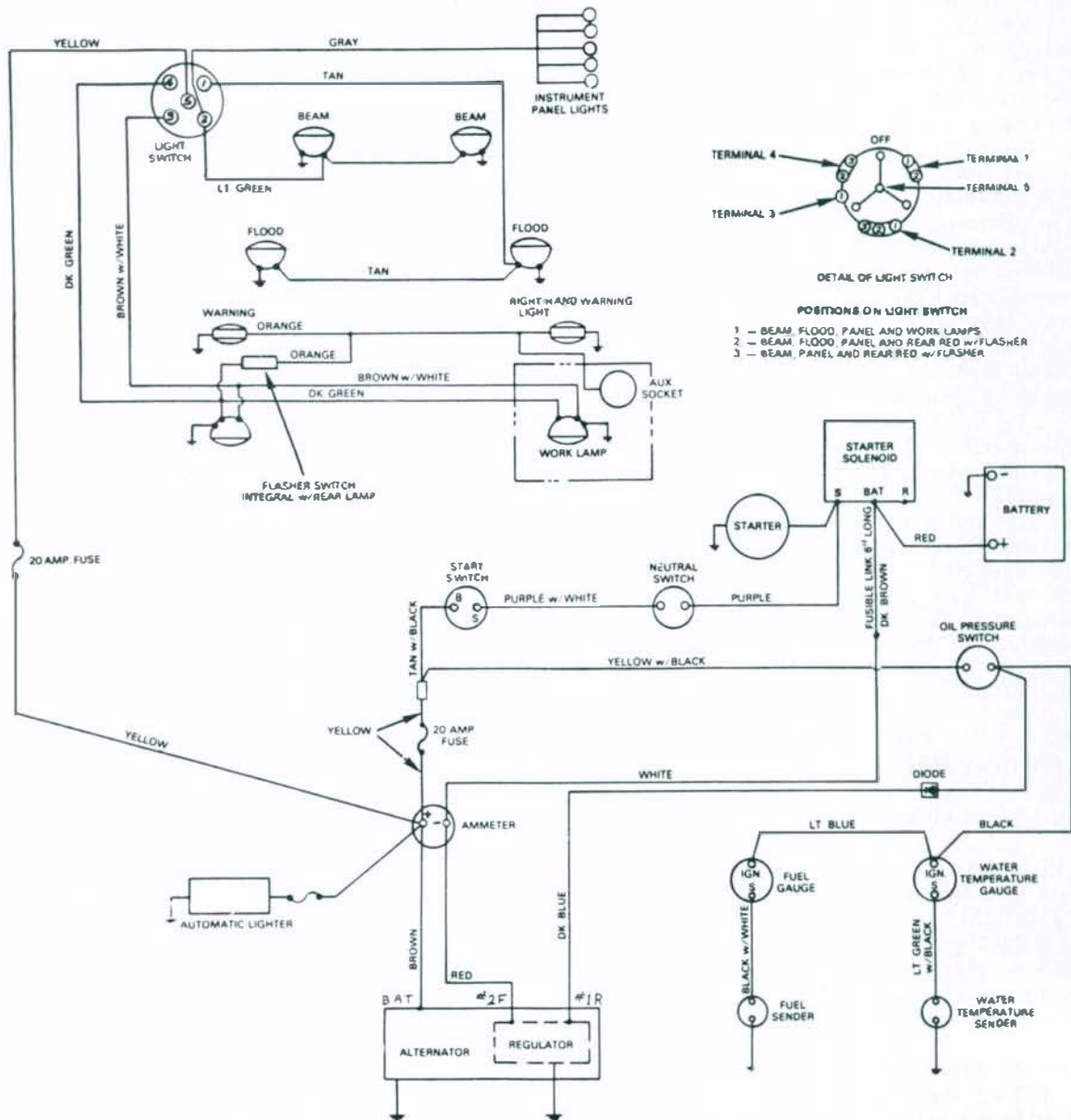

Fig. 247—Wiring diagram for MF230, MF235 and MF245 tractors equipped with diesel engine and flat top fenders. Refer also to Fig. 249 for models with dished fenders.

kPa (1900-2100 psi) and a "squealing" noise from control valve is heard, loosen control handle detent screw (2) until handle releases within specified pressure range. If control handle does not kick out of detent and no "squealing" sound is heard, shut off engine and remove end plug (15) from valve. Turn regulator adjusting screw (17) outward to decrease kick out pressure. Reinstall plug and recheck for proper operation.

**Model MF250**

**237. OVERHAUL.** To disassemble auxiliary valve, remove single/double acting convertor valve (3—Fig. 246), check valve (4) and detent relief valve assembly (6) from valve body. Remove end cap (22). Unscrew retaining screw (21) and remove centering spring (19), spring seats (18) and end plate (17). Remove pivot bracket (8) with wiper seal

(9). Pull spool out of valve body and remove detent carrier (15), piston (12) and cage (11).

Inspect all parts for wear and renew as necessary. Valve spool and body are available only as a matched set. Be sure to renew all "O" rings.

When reassembling, use petroleum jelly to hold detent balls in place. Clean the threads of retaining screw (21) and valve spool, then apply a drop of thread locking compound to threads of screw before installing.

Check and adjust spool detent "kick out" pressure as outlined in paragraph 238.

**238. ADJUSTMENT.** To set valve spool detent "kick out" pressure, connect a suitable flow meter to auxiliary valve rear couplers. Operate engine at 1000 rpm and place control valve handle in "lift" position. Slowly close flow

meter restrictor valve and note pressure at which control valve kicks out of detent and returns to neutral. Valve should kick out of detent at approximately 16550 kPa (2400 psi). Kick out pressure is adjusted by turning detent relief valve adjusting screw (S) in or out.

# WIRING DIAGRAMS

**All Models**

239. Refer to the appropriate Fig. 247 through Fig. 250 for tractor wiring diagram. Service procedures covering electrical system components are contained in paragraphs 100 through 109.

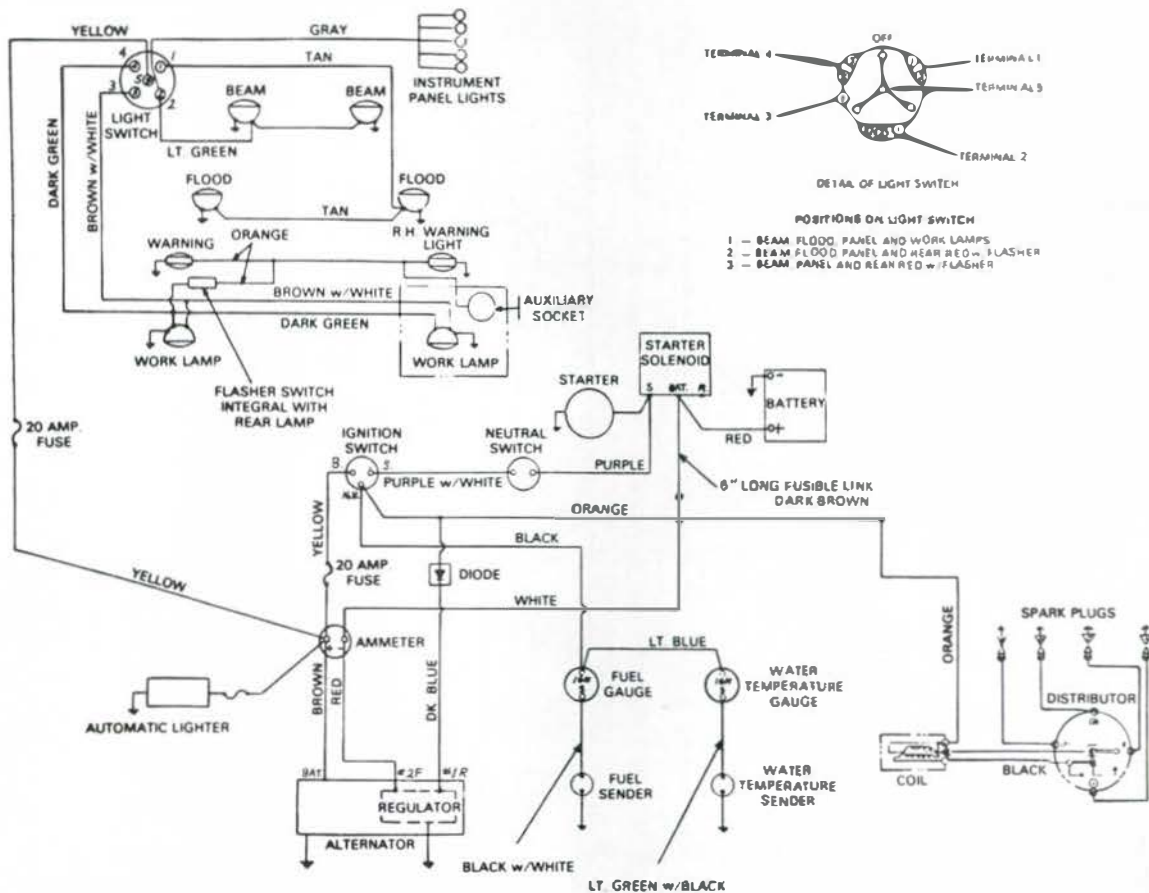

Fig. 248—Wiring diagram for MF230, MF235 and MF245 tractors equipped with gas/oil engine and flat top fenders. Refer also to Fig. 249 for models with dished fenders.

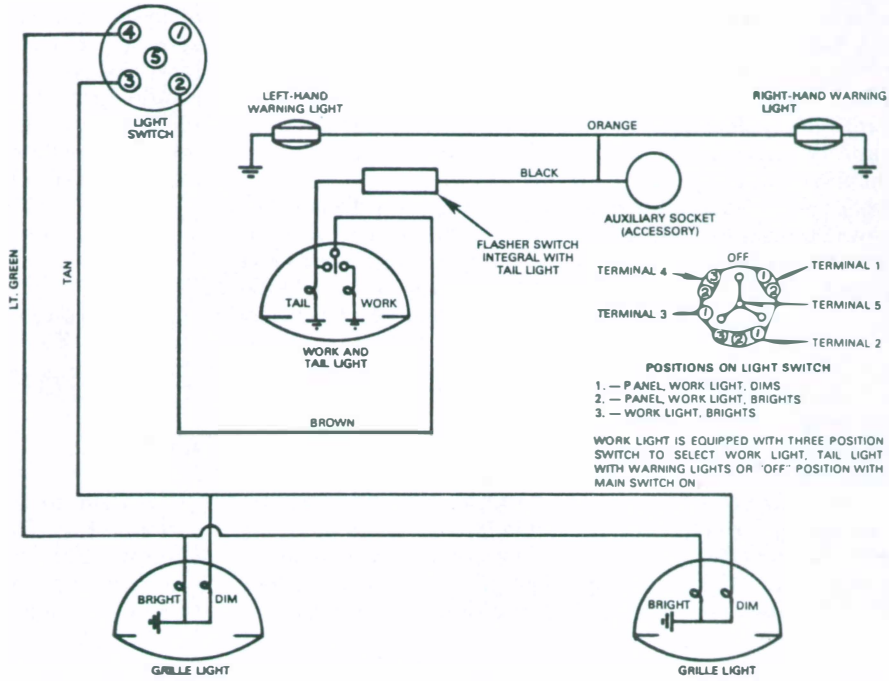

Fig. 249—Wiring diagram showing differences for models with dished fenders. Refer to Fig. 247 or Fig. 248 for general wiring diagrams.

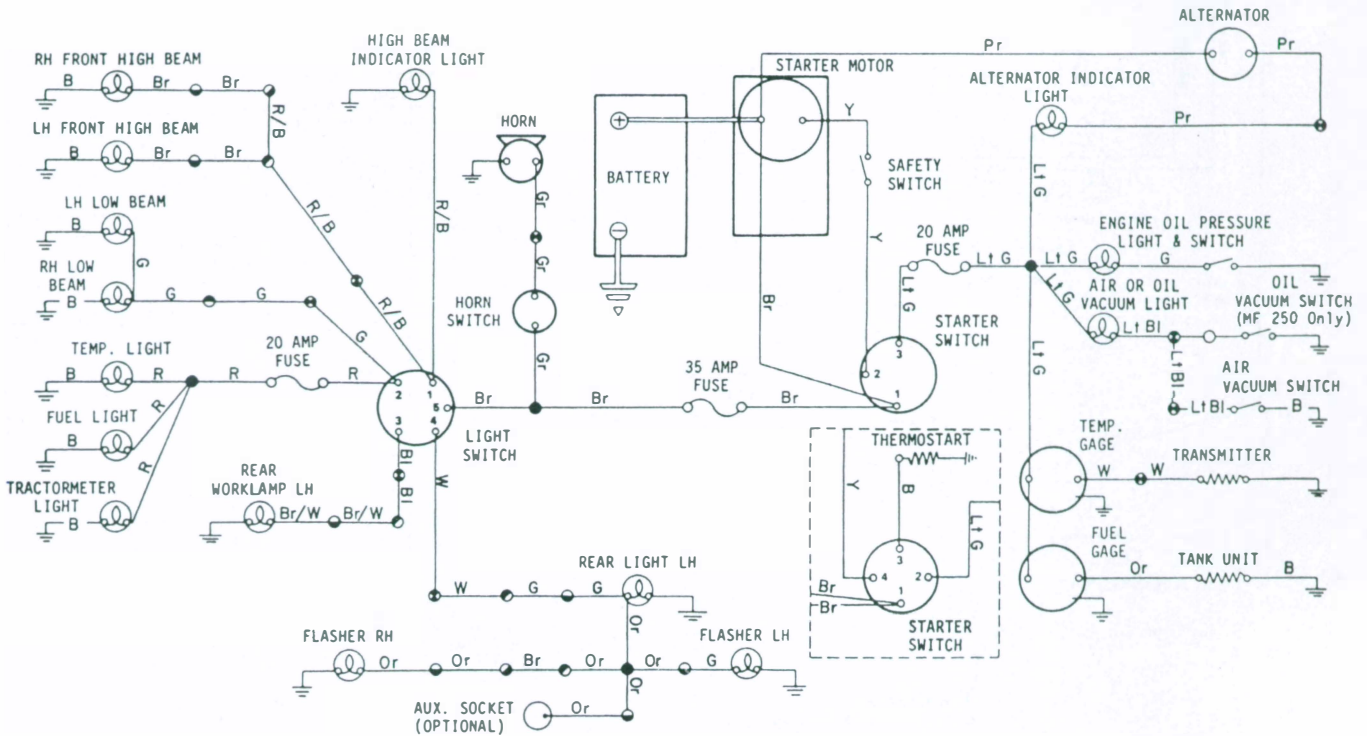

Fig. 250—Wiring diagram for Models MF240 and MF250.

B. Black  
 Bl. Blue  
 Br. Brown  
 G. Green  
 Gr. Gray  
 Or. Orange  
 Pr. Purple  
 R. Red  
 W. White  
 Y. Yellow  
 Lt. Light