



Service Manual

CBT 1000

CBT 1000E

Line Array Column Speaker





Table of Contents

Product Specifications

Exploded View Diagram - CBT 1000

Exploded View Diagram - CBT 1000E

Exploded View Diagram - Box Bracket

Exploded View Diagram - Wall Bracket

Exploded View Diagram - Offset Bracket

Exploded View Diagram - Suspended Bracket

Exploded View Diagram - Splicer Bracket

Exploded View Diagram - Tilt And Pan Bracket

Customer Drawings

Bill of Materials





CBT 1000

Constant Beamwidth Technology™ High-Output
Two-Way Line Array Column with Adjustable
Vertical Coverage and Tapered Horizontal Waveguide

Specifications:

System:

Components:	Six (6) 165 mm (6.5 in) LF drivers Twenty-four (24) 25 mm (1 in) HF drivers
Frequency Range (-10 dB) ¹ :	45 Hz – 20 kHz
Sensitivity (2.83V@ 1m) ^{1,2} :	102 dB (at highest sensitivity setting: “Point” pattern up, “Point” pattern down, “Speech” voicing, in free space) 95 dB (at lowest sensitivity setting: “Medium” pattern up, “Downfill” pattern down, “Music” voicing in free space)
Nominal Impedance:	4 ohms (4 ohms above 1 kHz; 8 ohms below 800 Hz)
Power Capacity ³ :	1500 W (6000 W peak), 2 hrs 1000 W (4000 W peak), 100 hrs
Maximum Input Voltage:	65.0 Volts RMS (2 hrs), 130.0 Volts Peak
Max SPL ⁴ :	Highest directivity setting: (“Point” pattern up, “Point” pattern down) with “Speech” voicing: 131 dB continuous average pink noise 134 dB continuous program 137 dB Peak Highest directivity setting: (“Point” pattern up, “Point” pattern down) with “Music” voicing: 127 dB continuous average pink noise 130 dB continuous program 133 dB peak Lowest directivity setting: (“Medium” pattern up, “Downfill” pattern down) with “Speech” voicing: 128 dB continuous average pink noise 131 dB continuous program 134 dB peak Lowest directivity setting: (“Medium” pattern up, “Downfill” pattern down) with “Music” voicing: 124 dB continuous average pink noise 127 dB continuous program 130 dB peak
Vertical Coverage Settings:	Coverage is effective (frequency response similar) beyond the traditional -6 dB coverage angles. This is especially useful in compensating for differences in listening distances. Figures show both the -6 dB and -12 dB coverage angles (at 3 kHz). Angles are in reference to cabinet aiming axis.
Pattern UP Settings:	“Point”: -6dB @ +7°, -12 dB @ +12° “Tight”: -6dB @ +9°, -12 dB @ +15° “Narrow”: -6dB @ +10°, -12 dB @ +20° “Medium”: -6dB @ +13°, -12 dB @ +24°
Pattern DOWN Settings:	“Point”: -6dB @ -7°, -12 dB @ -12° “Narrow”: -6dB @ -10°, -12 dB @ -20° “Broad”: -6dB @ -17°, -12 dB @ -28° “Downfill”: -6dB @ -20°, -12 dB @ -35°
Horizontal Coverage:	Patent-pending Tapered Horizontal Waveguide continuously variable. Long-throw (top) section: 100° Middle section: 130° Short-throw (bottom) section: 160°
Recommended High-Pass:	35Hz, 24 dB/oct or greater

Transducers:

Low Frequency Drivers:	6 pcs, 165 mm (6.5 in) drivers, lightweight neodymium motors, 50 mm (2.0 in) diameter voice coils, copper-capped pole tips to minimize flux modulation and linearize inductance, 16 mm (0.63 in) long coil for high linear drive and high power handling, damped blended textile surround, coated cones for moisture, UV and salt resistance. Magnetically shielded.
High Frequency Drivers:	24 pcs, 25 mm (1 in) drivers, neodymium, encased magnet and coated diaphragm for moisture, UV, and salt resistance.

CBT 1000 Two-Way Line Array Column with Adjustable Vertical Coverage and Tapered Horizontal Waveguide

Enclosure:

Enclosure:	Fiberglass reinforced ABS cabinet, powder coated 1050 aluminum grille
Outdoor Capability:	IP-55 rated, per IEC529, when installed with optional MTC-PC2 cover. Exceeds Mil Spec 810 for humidity, temperature & UV, ASTM G85 for acid-air/salt-spray (200 hrs).
Colors:	Black (RAL9004) or White (-WH) (RAL9016)
Insert Points:	14 individual M8 inserts on back panel (20 mm deep) for use with swivel (pan)/tilt bracket(s), forged-shoulder steel eyebolts, swivel rings, and after-market third-party brackets, plus 4 individual M8 inserts on top and 4 on bottom of cabinet end-caps.
Mounting:	Included two-part swivel (pan)/tilt wall bracket provides continuously variable +/- 45 degree left-right swivel aiming (at no up/down tilt – see Bracket Guide for maximum swivel range at various up/down tilt angles), +/- 15 degree tilt in 1 degree fixed increment points. Fourteen (14) threaded mounting points located on back panel of cabinet conform to industry standard rectangular 127 x 70 mm (5.0 x 2.75 in) pattern for legacy OmniMount® and other compatible third-party brackets. Four (4) threaded mount points on the top end-cap and four (4) on the bottom end-cap. Threaded mounting points can be utilized for suspension. (Always use multiple mounting points.)
Dimensions (H x W x D):	1020 mm x 250 mm x 345 mm (40.2 x 9.9 x 13.6 in)
Net Weight (cabinet):	24.5 kg (54 lbs)
Shipping Weight:	38.6 kg (85 lbs)
Included Accessories:	Two-piece swivel (pan)/tilt wall bracket
Optional Accessories:	MTC-PC2 terminal panel cover MTC-CBT1K-ACC1 Accessory kit includes: 2 pcs MTC-CBT-FM3 flush-mount brackets 1 pc MTC-CBT-OS3 offset bracket (for CBT 1000+1000E array – works in conjunction with CBT 1000E's included Coupler Plate for locating CBT 1000E extension cabinet above CBT 1000 instead of below it) MTC-CBT-SUS3 CBT Series suspension bracket kit (2 pcs included to provide top and bottom attachment points)

¹Full space

²2.85V @ 1 meter, averaged 2 kHz to 6 kHz; same sensitivity in this range for CBT 1000 alone and CBT 1000+CBT 1000E (for more information see notes in FAQ); Subtract 3 dB for 2.00V @ 1 meter sensitivity.)

³IEC standard, full bandwidth pink noise with 6 dB crest factor.

⁴2 kHz - 6 kHz, calculated based on power rating and measured sensitivity, exclusive of power compression.

JBL continually engages in research related to product improvement.

Changes introduced into existing products without notice are an expression of that philosophy.

Exploded View Diagram - CBT 1000

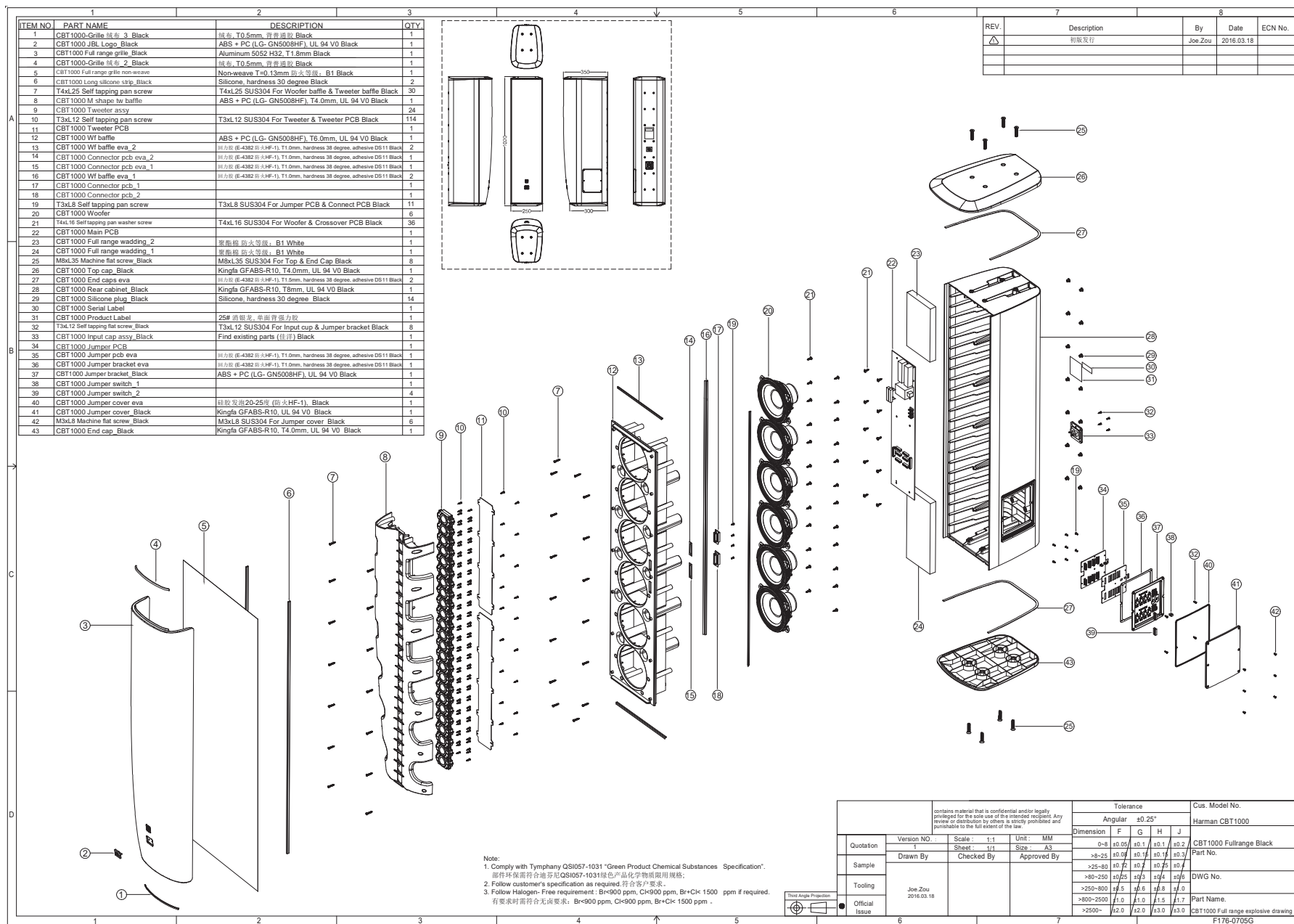

Exploded View Diagram - CBT 1000E

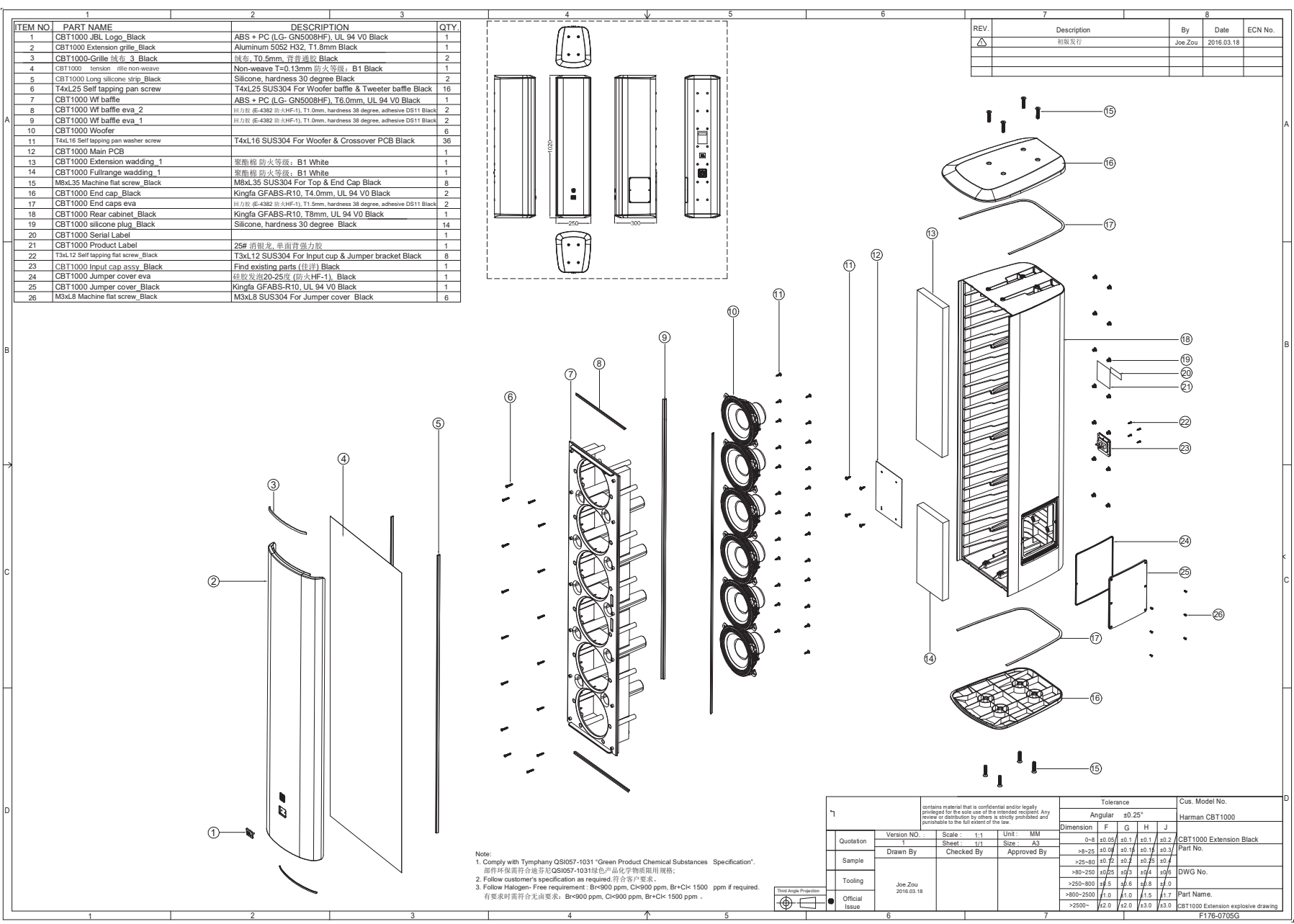

8 7 6 5 4 3 2 1

THESE DRAWINGS AND SPECIFICATIONS ARE THE PROPERTY OF HARMAN. DO NOT DISCLOSE, REPRODUCE OR PUBLISH WITHOUT WRITTEN HARMAN APPROVAL.

REVISION HISTORY				
REV.	DESCRIPTION	ZONE	DATE	BY
A	INITIAL RELEASE		6/24/2016	MN
B	ADDED NOTE FOR HARDWARE		11/21/2016	MN
C	REMOVE NOTE FOR HARDWARE		1/3/2017	MN
D	ADD NOTE 6 TO PACKAGING KIT		1/31/2017	MN

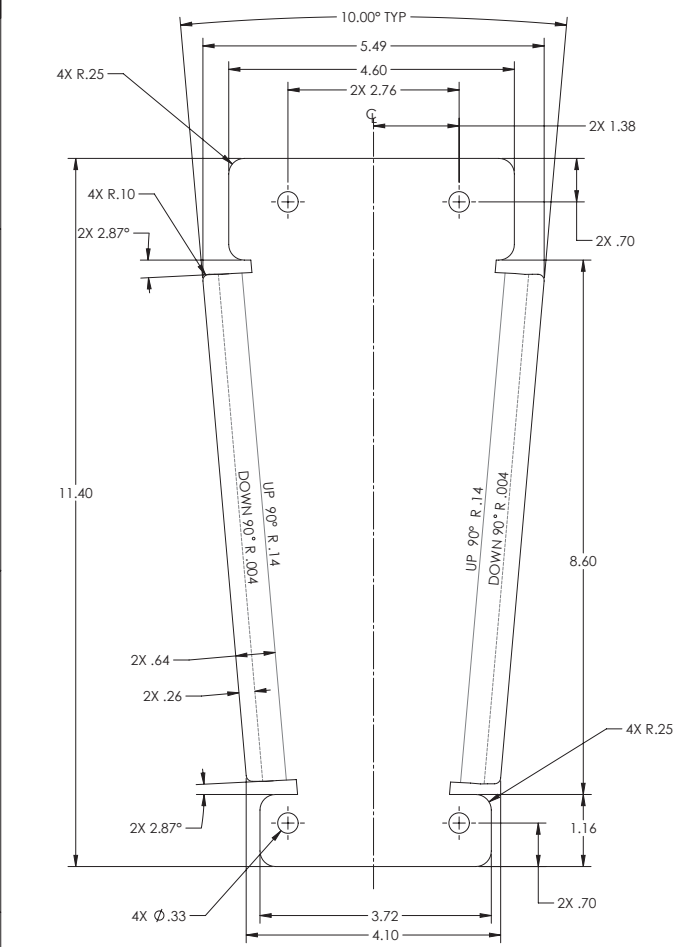

FLAT PATTERN

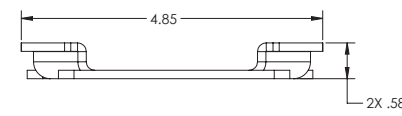
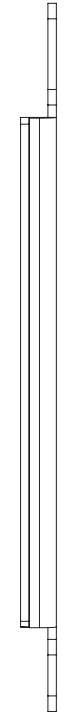
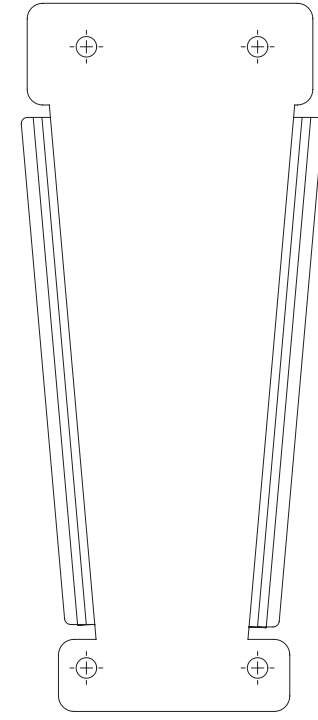
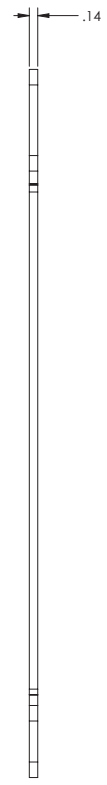

- 6. PART SHALL BE PACKAGED WITH THE FOLLOWING HARDWARE:
 - 8 M8 304 STAINLESS STEEL, PAN HEAD PHILLIPS MACHINE SCREWS, 20MM IN LENGTH, WITH BLACK FINISH.
 - 8 M8 304 STAINLESS STEEL, GENERAL PURPOSE WASHERS, WITH BLACK FINISH.
 - 8 M8 304 STAINLESS STEEL, SPLIT LOCK WASHERS, WITH BLACK FINISH.
- 5. DIMENSIONS ARE SHOWN FOR INSPECTION PURPOSES ONLY. PART SHALL BE PRODUCED PER JBL SUPPLIED 3D STEP FILE 5077295C.STEP.
- 4. BREAK ALL EDGES.
- 3. RoHS COMPLIANT ZINC PLATING SHOULD BE CONDUCTED AFTER PERFORATING, FORMING AND PUNCHING.
- 2. FINISH:
 - 5 STAGE IRON PHOSPHATE CONVERSION WASH PRIOR TO POWDER COAT.
 - POWDER COAT TO BE RAL9004 BLACK POLYESTER, 30 +/- 5% GLOSS PER AAMA 2604.
 - CLEAR ZINC PER ASTM B633 TYPE V SC2.
- 1. MATERIAL: 10 GA (0.141 IN/3.57 MM) THICK ASTM A1008 SS GRADE 40 STEEL OR SPCC PER JIS G3141 STEEL.

NOTES: (UNLESS OTHERWISE SPECIFIED)

<p>THIRD ANGLE PROJECTION</p>	<p>TOLERANCES UNLESS OTHERWISE SPECIFIED</p> <p>INCHES: 0.000 + 0.005 0.000 ± 0.011</p> <p>MILLIMETERS: 0.000 ± 0.1mm 0.000 ± 0.2mm 0.000 ± 0.5mm</p>		<p>HARMAN</p> <p>JBL Professional 8500 Balboa Blvd Northridge, CA 91329 USA</p>	
	<p>RESTRICTION OF HAZARDOUS SUBSTANCES</p> <p>ALL MATERIALS USED IN THIS PART MUST BE ROHS COMPLIANT</p> <p>SUPPLIER SHALL PROVIDE A CERTIFICATE OF ROHS COMPLIANT WITH THE FIRST ARTICLE</p>		<p>ROHS COMPLIANT</p> <p>DATE: 6/23/2016</p>	
<p>DRAWN BY: M. NIETO</p> <p>ENGINEER: M. NIETO</p>		<p>DATE: 6/23/2016</p>		<p>TITLE: MITC-CBT-FM3, BOX BRACKET, BLACK, CBT1000</p>
<p>SIZE: D</p>		<p>PART NO.: 5077295</p>		<p>REV: D</p>
<p>SCALE: 1:1 SHEET 1 OF 1</p>				

8 7 6 5 4 3 2 1

8 7 6 5 4 3 2 1

THESE DRAWINGS AND SPECIFICATIONS ARE THE PROPERTY OF HARMAN. DO NOT DISCLOSE, REPRODUCE OR PUBLISH WITHOUT WRITTEN HARMAN APPROVAL.

REVISION HISTORY				
REV.	DESCRIPTION	ZONE	DATE	BY
A	INITIAL RELEASE		6/24/2016	MN
B	ADDED HARDWARE NOTE		11/21/2016	MN

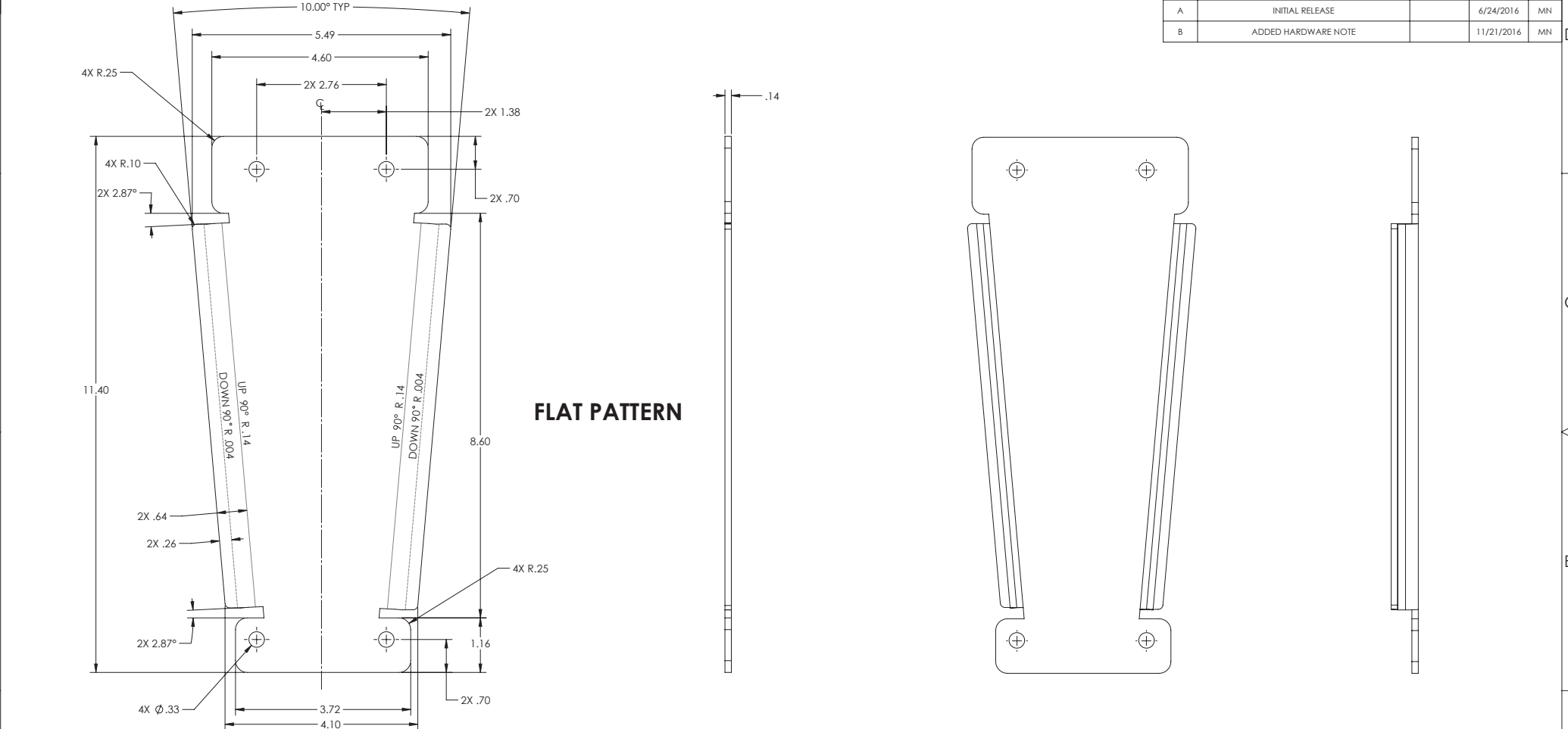

FLAT PATTERN

6. PART SHALL BE PACKAGED WITH THE FOLLOWING HARDWARE:
 - 8 M8 304 STAINLESS STEEL, PAN HEAD PHILLIPS MACHINE SCREWS, 20MM IN LENGTH, WITH WHITE FINISH.
 - 8 M8 304 STAINLESS STEEL, GENERAL PURPOSE WASHERS, WITH WHITE FINISH.
 - 8 M8 304 STAINLESS STEEL, SPLIT LOCK WASHERS, WITH WHITE FINISH.
5. DIMENSIONS ARE SHOWN FOR INSPECTION PURPOSES ONLY. PART SHALL BE PRODUCED PER JBL SUPPLIED 3D STEP FILE 5077295A.STEP.
4. BREAK ALL EDGES.
3. ROHS COMPLIANT ZINC PLATING SHOULD BE CONDUCTED AFTER PERFORATING, FORMING AND PUNCHING.
2. FINISH:
 - 5 STAGE IRON PHOSPHATE CONVERSION WASH PRIOR TO POWDER COAT.
 - POWDER COAT TO BE RA19016 WHITE POLYESTER, .85% GLOSS PER AAMA 2604.
 - CLEAR ZINC PER ASTM B633 TYPE V SC2.
1. MATERIAL: ZINC PLATED COLD ROLL STEEL, 10 GAGE THICK.

NOTES: (UNLESS OTHERWISE SPECIFIED)

THIRD ANGLE PROJECTION 	TOLERANCES UNLESS OTHERWISE SPECIFIED INCHES: 0.0005 ± 0.0035 MILLIMETERS: 0.000 ± 0.1mm 0.001 ± 0.021 0.002 ± 0.02 mm FRACTIONAL: ±1/32 0.001 ± 0.02 mm		HARMAN JBL Professional 8500 Balboa Blvd Northridge, CA 91329 USA
	DIMENSIONS SHOWN ARE FOR REFERENCE AND INSPECTION ONLY. REFER TO 3D MODEL PROVIDED WITH THIS DRAWING FOR OVERALL DEFINITION OF PART GEOMETRY.		
RESTRICTION OF HAZARDOUS SUBSTANCES ALL MATERIALS USED IN THIS PART MUST BE ROHS COMPLIANT SUPPLIER SHALL PROVIDE A CERTIFICATE OF ROHS COMPLIANT WITH THE FIRST ARTICLE	DRAWN BY: M. NIETO DESIGNED BY: M. NIETO ENGINEER: M. NIETO	DATE: 6/23/2016 DATE: 6/23/2016	TITLE: MITC-CBT-FM3, BOX BRACKET, WHITE, CBT1000 PART NO.: 5078200 REV: B
SCALE: 1:1			SHEET 1 OF 1

8 7 6 5 4 3 2 1

THESE DRAWINGS AND SPECIFICATIONS ARE THE PROPERTY OF HARMAN. DO NOT DISCLOSE, REPRODUCE OR PUBLISH WITHOUT WRITTEN HARMAN APPROVAL.

REVISION HISTORY				
REV.	DESCRIPTION	ZONE	DATE	BY
A	INITIAL RELEASE		6/23/2016	MN

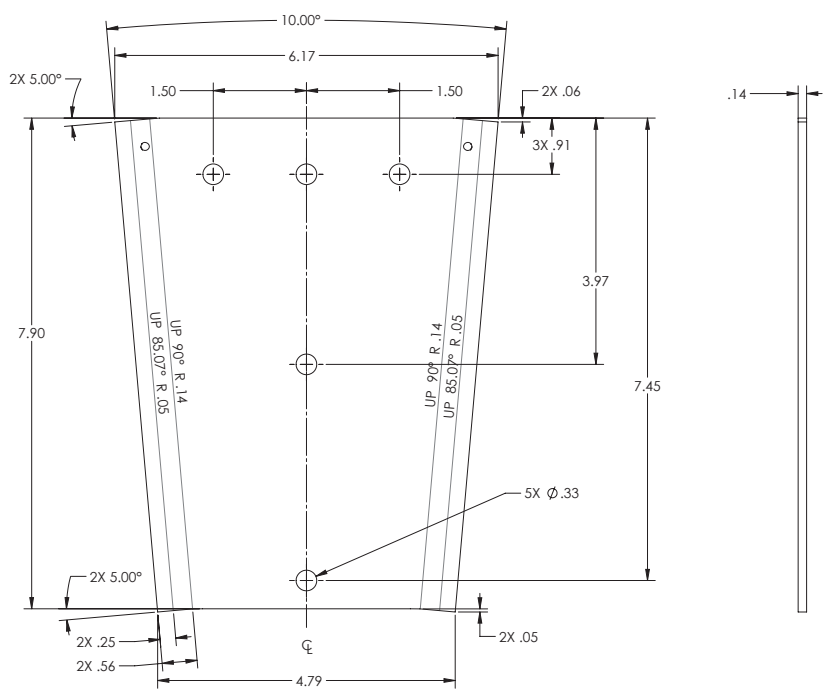

FLAT PATTERN

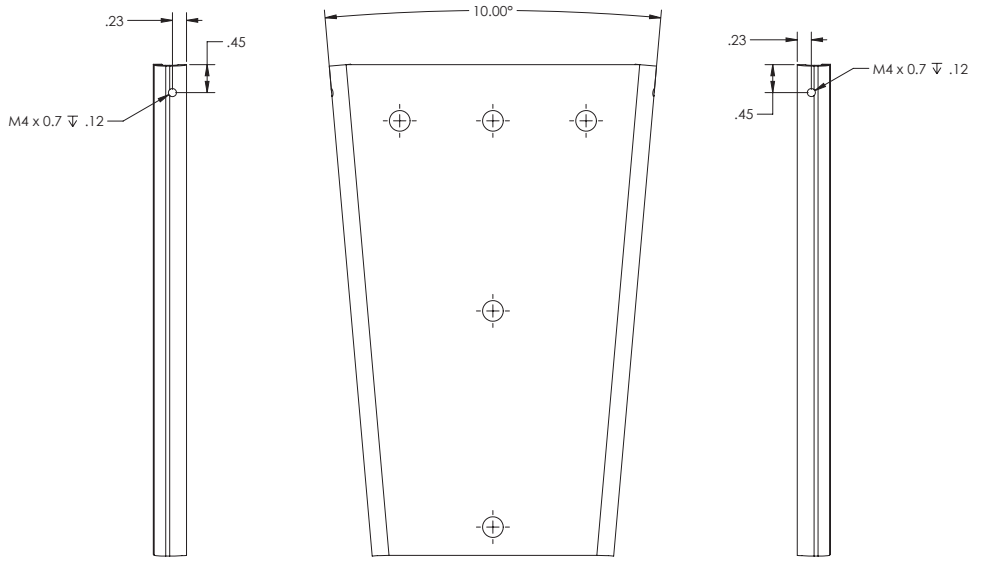

FOLDED PATTERN

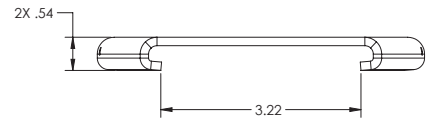

- 5. DIMENSIONS ARE SHOWN FOR INSPECTION PURPOSES ONLY. PART SHALL BE PRODUCED PER JBL SUPPLIED 3D STEP FILE 5077294A.STEP.
- 4. BREAK ALL EDGES.
- 3. RoHS COMPLIANT ZINC PLATING SHOULD BE CONDUCTED AFTER PERFORATING, FORMING AND PUNCHING.

- 2. FINISH:
 - 5 STAGE IRON PHOSPHATE CONVERSION WASH PRIOR TO POWDER COAT.
 - POWDER COAT TO BE RAL9016 WHITE POLYESTER, .85% GLOSS PER AAMA 2604.
 - CLEAR ZINC PER ASTM B633 TYPE V SC2.

- 1. MATERIAL: ZINC PLATED COLD ROLL STEEL, 10 GAGE THICK.

NOTES: (UNLESS OTHERWISE SPECIFIED)

THIRD ANGLE PROJECTION DIMENSIONS SHOWN ARE FOR REFERENCE AND INSPECTION ONLY. REFER TO 3D MODEL PROVIDED WITH THIS DRAWING FOR OVERALL DEFINITION OF PART GEOMETRY.	TOLERANCES UNLESS OTHERWISE SPECIFIED INCHES: 0.000 ± 0.005" MILLIMETERS: 0.000 ± 0.1mm 0.001 ± 0.01" 0.002 ± 0.02mm FRACTIONAL: ± 1/32		HARMAN JBL Professional 8500 Balboa Blvd Northridge, CA 91329 USA
	RESTRICTION OF HAZARDOUS SUBSTANCES ALL MATERIALS USED IN THIS PART MUST BE ROHS COMPLIANT SUPPLIER SHALL PROVIDE A CERTIFICATE OF ROHS COMPLIANT WITH THE FIRST ARTICLE		
ROHS COMPLIANT	DRAWN BY: M. NIETO DESIGNED BY: M. NIETO ENGINEER: M. NIETO	DATE: 6/23/2016 DATE: 6/23/2016	TITLE: WALL BRACKET, WHITE, MCT-CBT-FM3, CBT1000 SIZE: D PART NO.: 5078202 REV: A SCALE: 1:1 SHEET 1 OF 1

THESE DRAWINGS AND SPECIFICATIONS ARE THE PROPERTY OF HARMAN. DO NOT DISCLOSE, REPRODUCE OR PUBLISH WITHOUT WRITTEN HARMAN APPROVAL.

REVISION HISTORY				
REV.	DESCRIPTION	ZONE	DATE	BY
A	INITIAL RELEASE		6/28/2016	MN
B	INCLUDE HARDWARE IN PACKAGING NOTE 6		8/15/2016	MN

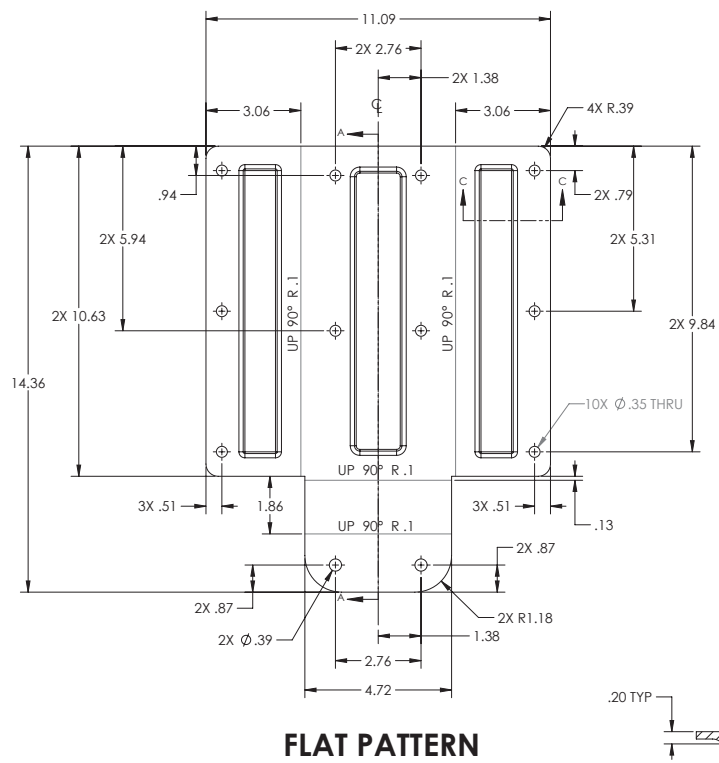

FLAT PATTERN

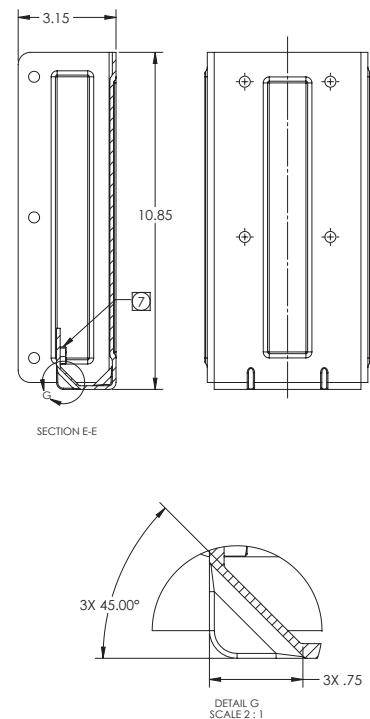
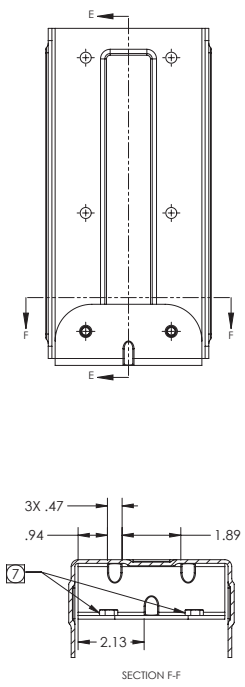
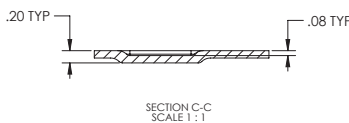
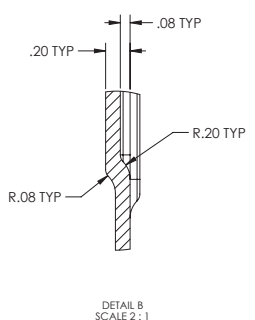
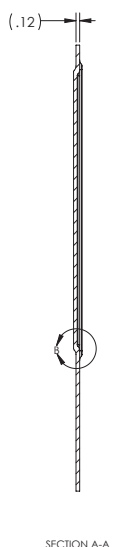

- 7. M8 ZINC PLATED STAINLESS STEEL PRESS IN NUT TO BE INSERTED ON THE INSIDE BEND OF PART PRIOR TO PAINTING.
- 6. PART SHALL BE PACKAGED TO PREVENT DAMAGE DURING SHIPPING. PART SHALL ALSO BE PACKAGED WITH THE FOLLOWING HARDWARE:
 - QUANTITY OF 8 M8 304 STAINLESS STEEL, PAN HEAD PHILIPS HEAD MACHINE SCREWS, 20 MM IN LENGTH, WITH BLACK OXIDE FINISH.
 - QUANTITY OF 8 M8 304 STAINLESS STEEL, GENERAL PURPOSE WASHERS, WITH BLACK OXIDE FINISH.
 - QUANTITY OF 8 M8 304 STAINLESS STEEL, SPLIT LOCK WASHERS, WITH BLACK OXIDE FINISH.
- 5. PART TO BE FREE OF BURRS AND SHARP EDGES.
- 4. USE MINIMAL BEND RADIUS AND TEAR RELIEFS UNLESS OTHERWISE SPECIFIED.
- 3. DIMENSIONS ARE SHOWN FOR INSPECTION PURPOSES ONLY. PART SHALL BE PRODUCED PER JBL SUPPLIED 3D STEP FILE 5078119A.STEP.
- 2. FINISH:
 - 5 STAGE IRON PHOSPHATE CONVERSION WASH PRIOR TO POWDER COAT.
 - POWDER COAT TO BE CARDINAL T241-BK59 BLACK POLYESTER TGIC 0.004 IN (.1MM) THICK.
 - CLEAR ZINC PER ASTM B633 TYPE V SC2.
- 1. MATERIAL: .118 IN (3 MM) THICK ASTM A1008 SS GRADE 40 STEEL OR SPCC PER JIS G3141 STEEL.

NOTES: (UNLESS OTHERWISE SPECIFIED)

<p>THIRD ANGLE PROJECTION</p> <p>DIMENSIONS SHOWN ARE FOR REFERENCE AND INSPECTION ONLY. REFER TO 3D MODEL PROVIDED WITH THIS DRAWING FOR OVERALL DEFINITION OF PART GEOMETRY.</p>	<p>TOLERANCES UNLESS OTHERWISE SPECIFIED</p> <p>INCHES: 0.00XX ± 0.005"</p> <p>MILLIMETERS: 0.0XX ± 0.1mm</p> <p>FRACTIONAL: ± 1/32</p> <p>ANGULAR: ± 0.5°</p> <p>BREAK ALL SHARP EDGES</p> <p>INSPECTION DIMENSION</p>	<p>HARMAN</p> <p>JBL Professional 8500 Balboa Blvd Northridge, CA 91329 USA</p>	
		<p>RESTRICTION OF HAZARDOUS SUBSTANCES</p> <p>ALL MATERIALS USED IN THIS PART MUST BE ROHS COMPLIANT</p> <p>SUPPLIER SHALL PROVIDE A CERTIFICATE OF ROHS COMPLIANT WITH THE FIRST ARTICLE</p>	<p>ROHS COMPLIANT</p> <p>DATE: 6/27/2016</p>

THESE DRAWINGS AND SPECIFICATIONS ARE THE PROPERTY OF HARMAN. DO NOT DISCLOSE, REPRODUCE OR PUBLISH WITHOUT WRITTEN HARMAN APPROVAL.

REVISION HISTORY				
REV.	DESCRIPTION	ZONE	DATE	BY
A	INITIAL RELEASE		6/28/2016	MN

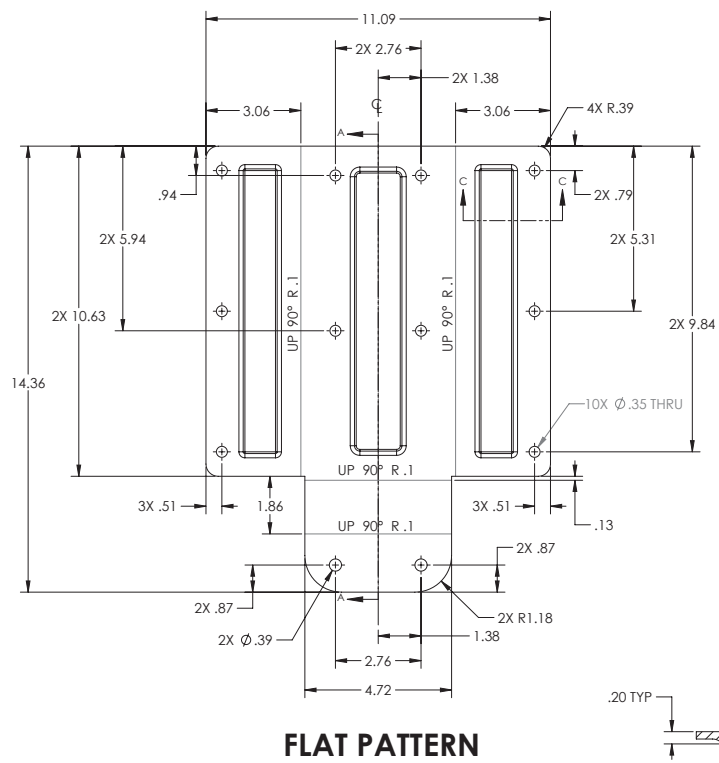

FLAT PATTERN

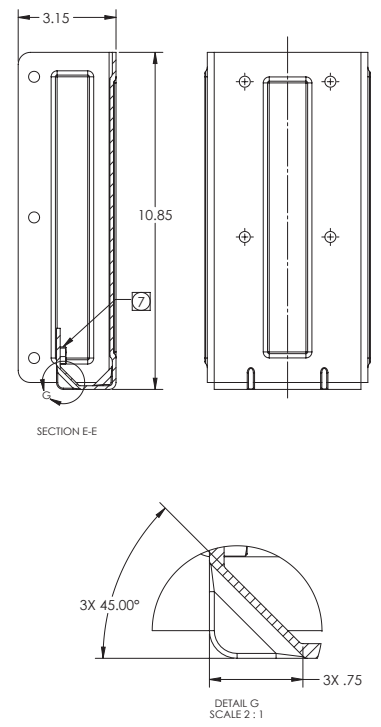
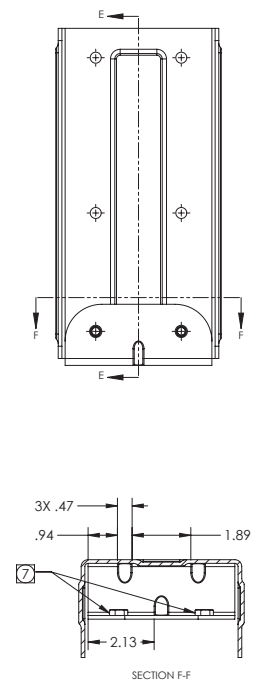
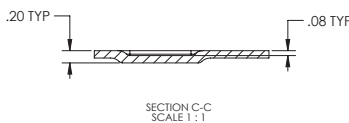
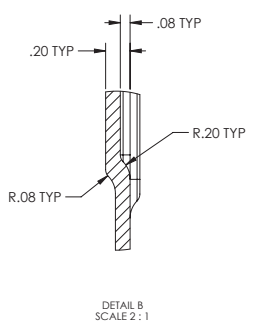
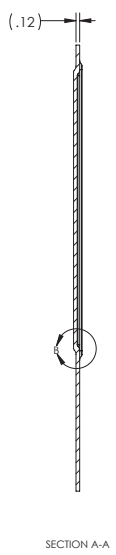

- 7. M8 ZINC PLATED STAINLESS STEEL PRESS IN NUT TO BE INSERTED ON THE INSIDE BEND OF PART PRIOR TO PAINTING.
- 6. PART SHALL BE PACKAGED TO PREVENT DAMAGE DURING SHIPPING. PART SHALL ALSO BE PACKAGED WITH THE FOLLOWING HARDWARE:
 - QUANTITY OF 8 M8 304 STAINLESS STEEL, PAN HEAD PHILIPS HEAD MACHINE SCREWS, 20 MM IN LENGTH, WITH WHITE FINISH.
 - QUANTITY OF 8 M8 304 STAINLESS STEEL, GENERAL PURPOSE WASHERS, WITH WHITE FINISH.
 - QUANTITY OF 8 M8 304 STAINLESS STEEL, SPLIT LOCK WASHERS, WITH WHITE FINISH.
- 5. PART TO BE FREE OF BURRS AND SHARP EDGES.
- 4. USE MINIMAL BEND RADIUS AND TEAR RELIEFS UNLESS OTHERWISE SPECIFIED.
- 3. DIMENSIONS ARE SHOWN FOR INSPECTION PURPOSES ONLY. PART SHALL BE PRODUCED PER JBL SUPPLIED 3D STEP FILE 5078119A.STEP.
- 2. FINISH:
 - 5 STAGE IRON PHOSPHATE CONVERSION WASH PRIOR TO POWDER COAT.
 - POWDER COAT TO BE AKZONOBEL GTJA-14961A-C WHITE POLYESTER, 0.6 MM (0.002 IN) THICK.
 - CLEAR ZINC PER ASTM B633 TYPE V SC2.
- 1. MATERIAL: .118 IN (3 MM) THICK ASTM A1008 SS GRADE 40 STEEL OR SPCC PER JIS G3141 STEEL.

NOTES: (UNLESS OTHERWISE SPECIFIED)

THIRD ANGLE PROJECTION 	TOLERANCES UNLESS OTHERWISE SPECIFIED INCHES: 0.000 + 0.005 MILLIMETERS: 0.000 + 0.1mm 0.000 + 0.01" 0.000 + 0.02 mm FRACTIONAL ± 1/32 D.X ± 0.5 mm		HARMAN JBL Professional 8500 Balboa Blvd Northridge, CA 91329 USA
	DIMENSIONS SHOWN ARE FOR REFERENCE AND INSPECTION ONLY. REFER TO 3D MODEL PROVIDED WITH THIS DRAWING FOR OVERALL DEFINITION OF PART GEOMETRY.		
ROHS ALL MATERIALS USED IN THIS PART MUST BE ROHS COMPLIANT SUPPLIER SHALL PROVIDE A CERTIFICATE OF ROHS COMPLIANT WITH THE FIRST ARTICLE	DRAWN BY: M. NIETO DESIGNED BY: M. NIETO ENGINEER: M. NIETO	DATE: 6/27/2016 DATE: 6/15/2016	TITLE: OFFSET BRACKET, MTC-CBT-053, WHITE, CBT 1000 PART NO.: 5079876 REV: A SCALE: 1:2 SHEET 1 OF 1

8 | 7 | 6 | 5 | 4 | 3 | 2 | 1

THESE DRAWINGS AND SPECIFICATIONS ARE THE PROPERTY OF HARMAN. DO NOT DISCLOSE, REPRODUCE OR PUBLISH WITHOUT WRITTEN HARMAN APPROVAL.

REVISION HISTORY				
REV.	DESCRIPTION	ZONE	DATE	BY
A	INITIAL RELEASE		6/27/2016	MN
B	HARDWARE ADDED TO PACKAGING. SEE NOTE 7.		8/15/2016	MN
C	ADD INSTALLATION GUIDE DOCUMENT		1/3/2017	MN

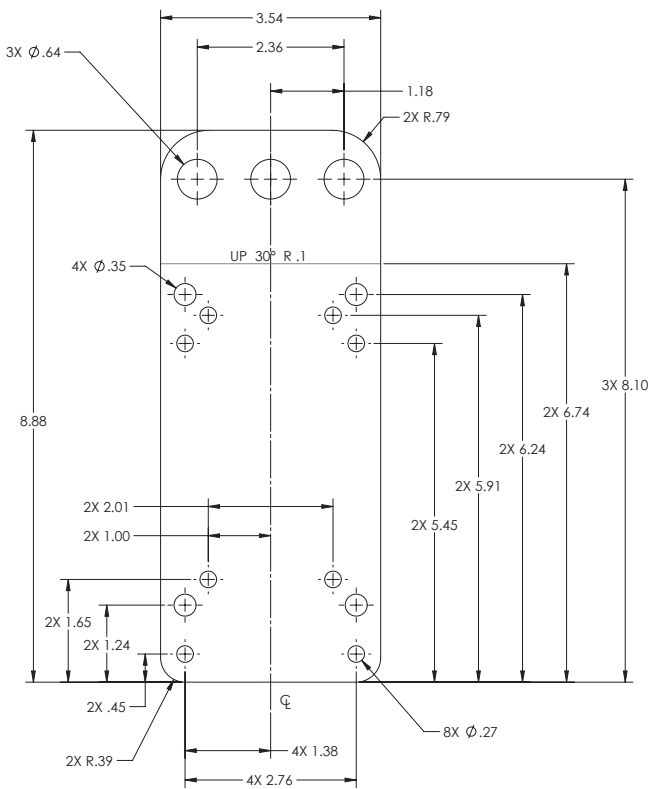

FLAT PATTERN

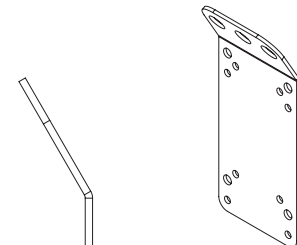
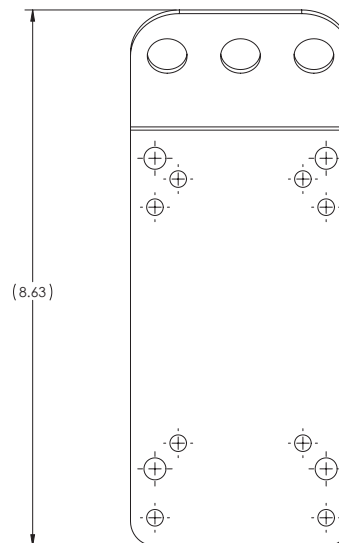

- 8. ADD INSTALLATION GUIDE DOCUMENT NO. 1000297491 TO PACKAGING.
- 7. THE FOLLOWING HARDWARE SHALL BE PACKAGED TOGETHER:
 - 8 M6 304 STAINLESS STEEL, PAN HEAD PHILLIPS MACHINE SCREWS, 20MM IN LENGTH, WITH BLACK FINISH.
 - 8 M6 304 STAINLESS STEEL, GENERAL PURPOSE WASHERS, WITH BLACK FINISH.
 - 8 M6 304 STAINLESS STEEL, SPLIT LOCK WASHERS, WITH BLACK FINISH.
 - 8 M8 304 STAINLESS STEEL, PAN HEAD PHILLIPS MACHINE SCREWS, 20MM IN LENGTH, WITH BLACK FINISH.
 - 8 M8 304 STAINLESS STEEL, PAN HEAD PHILLIPS MACHINE SCREWS, 40MM IN LENGTH, WITH BLACK FINISH.
 - 16 M8 304 STAINLESS STEEL, GENERAL PURPOSE WASHERS, WITH BLACK FINISH.
 - 16 M8 304 STAINLESS STEEL, SPLIT LOCK WASHERS, WITH BLACK FINISH.
- 6. 2 PIECES SHALL BE PACKAGED TOGETHER, AND SHALL BE PACKAGED TO PREVENT DAMAGE DURING SHIPPING.
- 5. PART TO BE FREE OF BURRS AND SHARP EDGES.
- 4. USE MINIMAL BEND RADIUS AND TEAR RELIEFS UNLESS OTHERWISE SPECIFIED.
- 3. DIMENSIONS ARE SHOWN FOR INSPECTION PURPOSES ONLY. PART SHALL BE PRODUCED PER JBL SUPPLIED 3D STEP FILE 5078120C.STEP.
- 2. 2. FINISH:
 - 5 STAGE IRON PHOSPHATE CONVERSION WASH PRIOR TO POWDER COAT.
 - POWDER COAT TO BE CARDINAL T241-BK59 BLACK POLYESTER TGIC 0.004 IN (.1MM) THICK.
 - CLEAR ZINC PER ASTM B633 TYPE V SC2.
- 1. MATERIAL: .118 IN (3 MM) THICK ASTM A1008 SS GRADE 40 STEEL OR SPCC PER JIS G3141 STEEL.

NOTES: (UNLESS OTHERWISE SPECIFIED)

<p>THIRD ANGLE PROJECTION</p>	TOLERANCES UNLESS OTHERWISE SPECIFIED INCHES: 0.0005 ± 0.0035 0.001 ± 0.01 FRACTIONAL ± 1/32		MILLIMETERS: 0.001 ± 0.1mm 0.001 ± 0.2mm 0.5 ± 0.5mm		HARMAN JBL Professional 8500 Balboa Blvd Northridge, CA 91329 USA
	DIMENSIONS SHOWN ARE FOR REFERENCE AND INSPECTION ONLY. REFER TO 3D MODEL PROVIDED WITH THIS DRAWING FOR OVERALL DEFINITION OF PART GEOMETRY.		ANGULAR: ±0.5° BREAK ALL SHARP EDGES (XXX) INSPECTION DIMENSION		
RESTRICTION OF HAZARDOUS SUBSTANCES ALL MATERIALS USED IN THIS PART MUST BE ROHS COMPLIANT SUPPLIER SHALL PROVIDE A CERTIFICATE OF ROHS COMPLIANT WITH THE FIRST ARTICLE	DRAWN BY: M. NIETO ENGINEER: M. NIETO	DATE: 6/27/2016 DATE: 6/14/2016	TITLE: SUSPENDED BRACKET, MTC-CBT-SUS3, CBT 1000	SIZE: D PART NO.: 5078120 SCALE: 1:1	REV: C SHEET 1 OF 1

THESE DRAWINGS AND SPECIFICATIONS ARE THE PROPERTY OF HARMAN. DO NOT DISCLOSE, REPRODUCE OR PUBLISH WITHOUT WRITTEN HARMAN APPROVAL.

REVISION HISTORY				
REV.	DESCRIPTION	ZONE	DATE	BY
A	INITIAL RELEASE		6/27/2016	MN
B	ADDED HARDWARE TO KIT		11/21/2016	MN
C	ADD INSTALLTION SPEC SHEET TO KIT		1/3/2017	MN

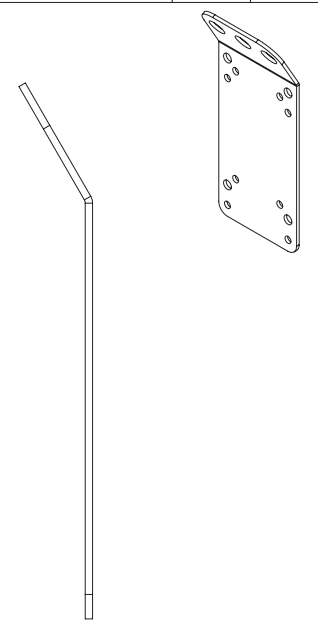
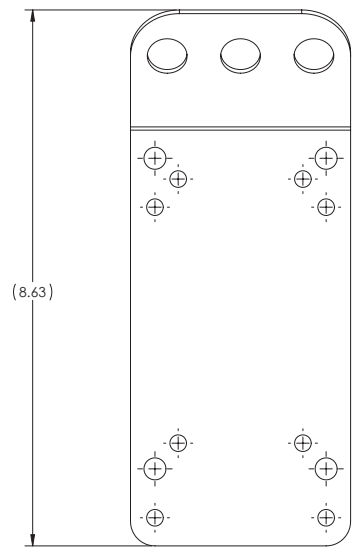
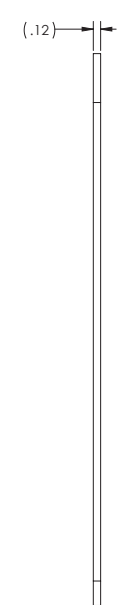
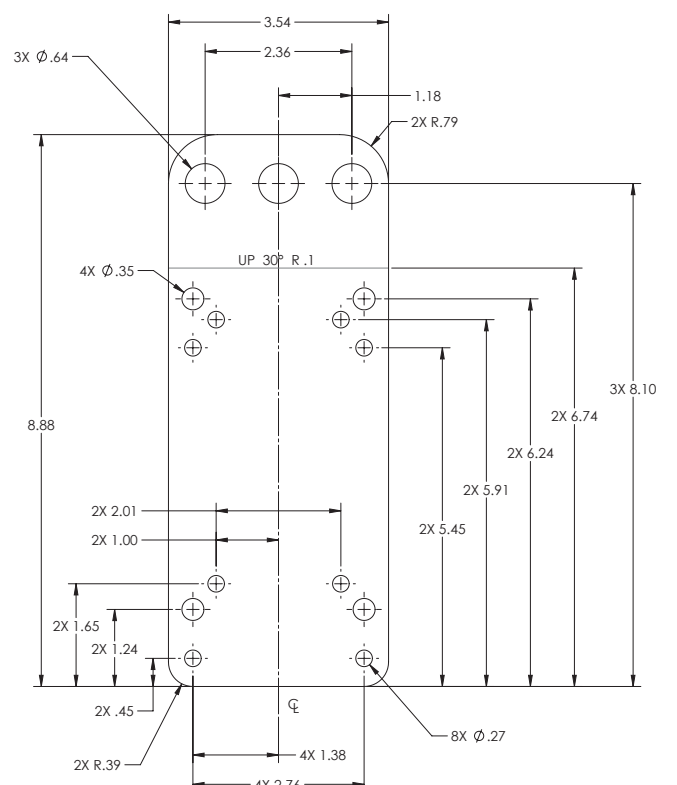

FLAT PATTERN

- 8. ADD INSTALLATION GUIDE DOCUMENT NO. 1000297491 TO PACKAGING.
- 7. THE FOLLOWING HARDWARE SHALL BE PACKAGED TOGETHER:
 - 8 M6 304 STAINLESS STEEL, PAN HEAD PHILLIPS MACHINE SCREWS, 20 MM IN LENGTH, WITH WHITE FINISH.
 - 8 M6 304 STAINLESS STEEL, GENERAL PURPOSE WASHERS, WITH WHITE FINISH.
 - 8 M6 304 STAINLESS STEEL, SPLIT LOCK WASHERS, WITH WHITE FINISH.
 - 8 M8 304 STAINLESS STEEL, PAN HEAD PHILLIPS MACHINE SCREWS, 20MM IN LENGTH, WITH WHITE FINISH.
 - 8 M8 304 STAINLESS STEEL, PAN HEAD PHILLIPS MACHINE SCREWS, 40MM IN LENGTH, WITH WHITE FINISH.
 - 16 M8 304 STAINLESS STEEL, GENERAL PURPOSE WASHERS, WITH WHITE FINISH.
 - 16 M8 304 STAINLESS STEEL, SPLIT LOCK WASHERS, WITH WHITE FINISH.
- 6. 2 PIECES SHALL BE PACKAGED TOGETHER, AND SHALL BE PACKAGED TO PREVENT DAMAGE DURING SHIPPING.
- 5. PART TO BE FREE OF BURRS AND SHARP EDGES.
- 4. USE MINIMAL BEND RADIUS AND TEAR RELIEFS UNLESS OTHERWISE SPECIFIED.
- 3. DIMENSIONS ARE SHOWN FOR INSPECTION PURPOSES ONLY. PART SHALL BE PRODUCED PER JBL SUPPLIED 3D STEP FILE 5078120C.STEP.

- 2. 2. FINISH:
 - 5 STAGE IRON PHOSPHATE CONVERSION WASH PRIOR TO POWDER COAT.
 - POWDER COAT TO BE AKZONOBEL GTJA-14961A-C WHITE POLYESTER, 0.6mm (0.002in) THICK.
 - CLEAR ZINC PER ASTM B633 TYPE V SC2.

- 1. MATERIAL: .118 IN (3 MM) THICK ASTM A1008 SS GRADE 40 STEEL OR SPCC PER JIS G3141 STEEL.

NOTES: (UNLESS OTHERWISE SPECIFIED)

<p>THIRD ANGLE PROJECTION</p>	<p>TOLERANCES UNLESS OTHERWISE SPECIFIED</p> <p>INCHES: 0.000 ± 0.005" 0.001 ± 0.01"</p> <p>MILLIMETERS: 0.000 ± 0.1mm 0.001 ± 0.02 mm FRACTIONAL: ±1/32</p>		<p>HARMAN</p> <p>JBL Professional 8500 Balboa Blvd Northridge, CA 91329 USA</p>
	<p>ANGULAR: ±0.5° BREAK ALL SHARP EDGES CROSS SECTION DIMENSION</p>		
<p>RESTRICTION OF HAZARDOUS SUBSTANCES</p> <p>ROHS COMPLIANT</p> <p>ALL MATERIALS USED IN THIS PART MUST BE ROHS COMPLIANT</p> <p>SUPPLIER SHALL PROVIDE A CERTIFICATE OF ROHS COMPLIANT WITH THE FIRST ARTICLE</p>	<p>DRAWN BY: M. NIETO</p> <p>DESIGNED BY: M. NIETO</p> <p>ENGINEER: M. NIETO</p>	<p>DATE: 6/27/2016</p> <p>DATE: 6/14/2016</p>	<p>TITLE: SUSPENDED BRACKET, MTC-CBT-SUS3, WHITE, CBT 1000</p> <p>SIZE: D</p> <p>PART NO.: 5080687</p> <p>REV: C</p> <p>SCALE: 1:1</p> <p>SHEET 1 OF 1</p>

8 | 7 | 6 | 5 | 4 | 3 | 2 | 1

THESE DRAWINGS AND SPECIFICATIONS ARE THE PROPERTY OF HARMAN. DO NOT DISCLOSE, REPRODUCE OR PUBLISH WITHOUT WRITTEN HARMAN APPROVAL.

REVISION HISTORY				
REV.	DESCRIPTION	ZONE	DATE	BY
A	INITIAL RELEASE		8/15/2016	MN

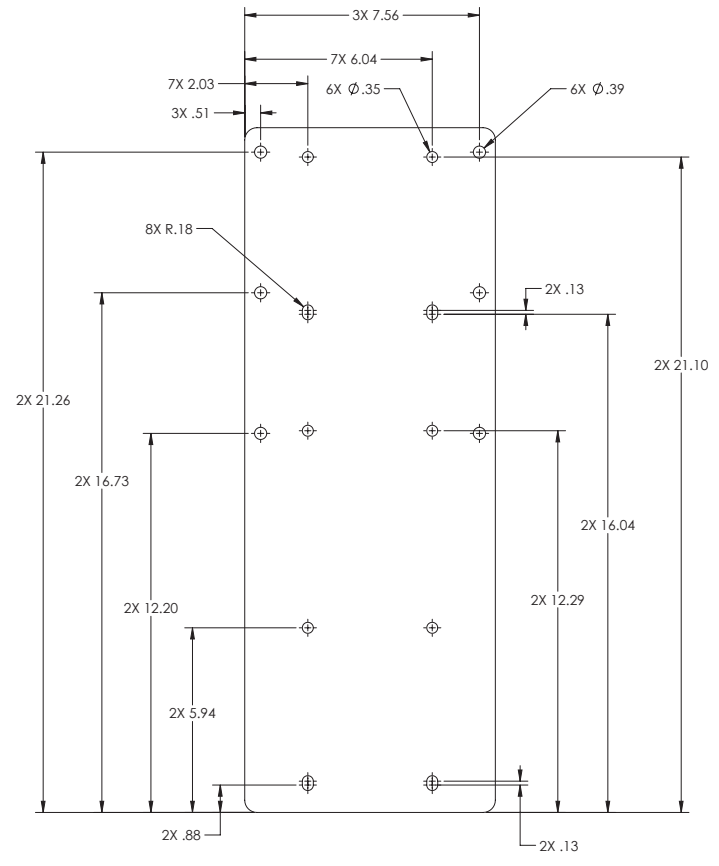
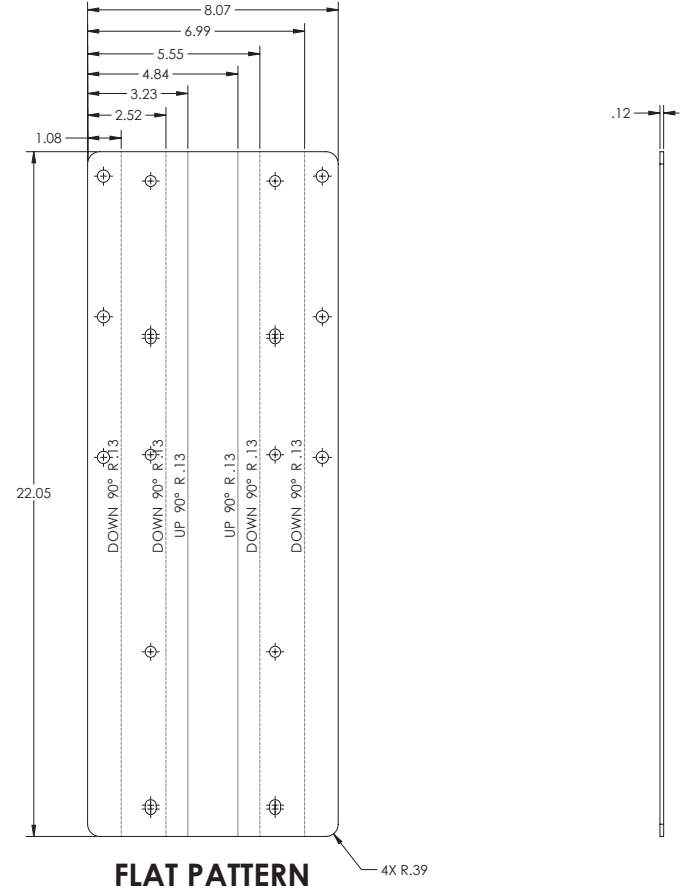

7. PART SHALL BE PACKAGED TO PREVENT DAMAGE DURING SHIPPING. PART SHALL ALSO BE PACKAGED WITH THE FOLLOWING HARDWARE:

- QUANTITY OF 8 M8 304 STAINLESS STEEL, PAN HEAD PHILLIPS MACHINE SCREW, LENGTH OF 20 MM, WITH BLACK OXIDE FINISH.
- QUANTITY OF 8 M8 GENERAL PURPOSE WASHERS, WITH BLACK OXIDE FINISH.
- QUANTITY OF 8 M8 SPLIT LOCK WASHERS, WITH BLACK OXIDE FINISH.

⑥ M8 ZINC PLATED STAINLESS STEEL PRESS IN NUT TO BE INSERTED ON THE INSIDE BEND OF PART PRIOR TO COATING.

5. PART TO BE FREE OF BURRS AND SHARP EDGES.

4. USE MINIMAL BEND RADIUS AND TEAR RELIEFS UNLESS OTHERWISE SPECIFIED.

3. DIMENSIONS ARE SHOWN FOR INSPECTION PURPOSES ONLY. PART SHALL BE PRODUCED PER JBL SUPPLIED 3D STEP FILE 5078884.STEP.

2. FINISH:

- 5 STAGE IRON PHOSPHATE CONVERSION WASH PRIOR TO POWDER COAT.
- POWDER COAT TO BE AKZONOBEL GTJN-14962A-C BLACK POLYESTER, 0.6mm (0.002 in) THICK.
- CLEAR ZINC PER ASTM B633 TYPE V SC2.

1. MATERIAL: .118 IN. (3 MM) THICK ASTM A10088 SS GRADE 40 STEEL OR SPCC PER JIS G3141 STEEL.

NOTES: (UNLESS OTHERWISE SPECIFIED)

	TOLERANCES UNLESS OTHERWISE SPECIFIED INCHES: 0.0005 ± 0.005" MILLIMETERS: 0.000 ± 0.1mm 0.001 ± 0.021" 0.002 ± 0.2mm FRACTIONAL: ± 1/32 0.001 ± 0.02mm 0.002 ± 0.5mm		HARMAN JBL Professional 8500 Balboa Blvd Northridge, CA 91329 USA
	DIMENSIONS SHOWN ARE FOR REFERENCE AND INSPECTION ONLY. REFER TO 3D MODEL PROVIDED WITH THIS DRAWING FOR OVERALL DEFINITION OF PART GEOMETRY.		
RESTRICTION OF HAZARDOUS SUBSTANCES ALL MATERIALS USED IN THIS PART MUST BE ROHS COMPLIANT SUPPLIER SHALL PROVIDE A CERTIFICATE OF ROHS COMPLIANT WITH THE FIRST ARTICLE	DRAWN BY: M. NIETO DESIGNED BY: M. NIETO ENGINEER: M. NIETO	DATE: 7/26/2016 DATE: 7/25/2016	TITLE: SPLICER BRACKET SIZE: D PART NO.: 5078884 REV: A SCALE: 1:2 SHEET 1 OF 2

8 | 7 | 6 | 5 | 4 | 3 | 2 | 1

8

7

6

5

↓

4

3

2

1

THESE DRAWINGS AND SPECIFICATIONS ARE THE PROPERTY OF HARMAN. DO NOT DISCLOSE, REPRODUCE OR PUBLISH WITHOUT WRITTEN HARMAN APPROVAL.

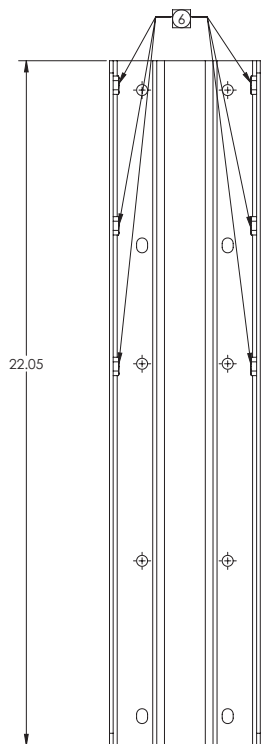
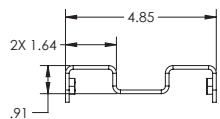

FOLDED PATTERN

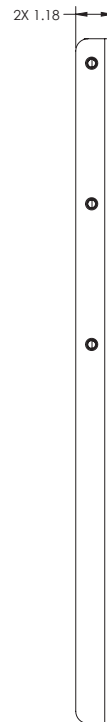

8

7

6

5

↑

4

3

2

1

HARMAN		JBL Professional 8500 Balboa Blvd Northridge, CA 91329 USA
TITLE SPLICER BRACKET		
SIZE D	PART NO. 5078884	REV A
SCALE: 1:1		SHEET 2 OF 2

8 | 7 | 6 | 5 | 4 | 3 | 2 | 1

THESE DRAWINGS AND SPECIFICATIONS ARE THE PROPERTY OF HARMAN. DO NOT DISCLOSE, REPRODUCE OR PUBLISH WITHOUT WRITTEN HARMAN APPROVAL.

REVISION HISTORY				
REV.	DESCRIPTION	ZONE	DATE	BY
A	INITIAL RELEASE		8/15/2016	MN

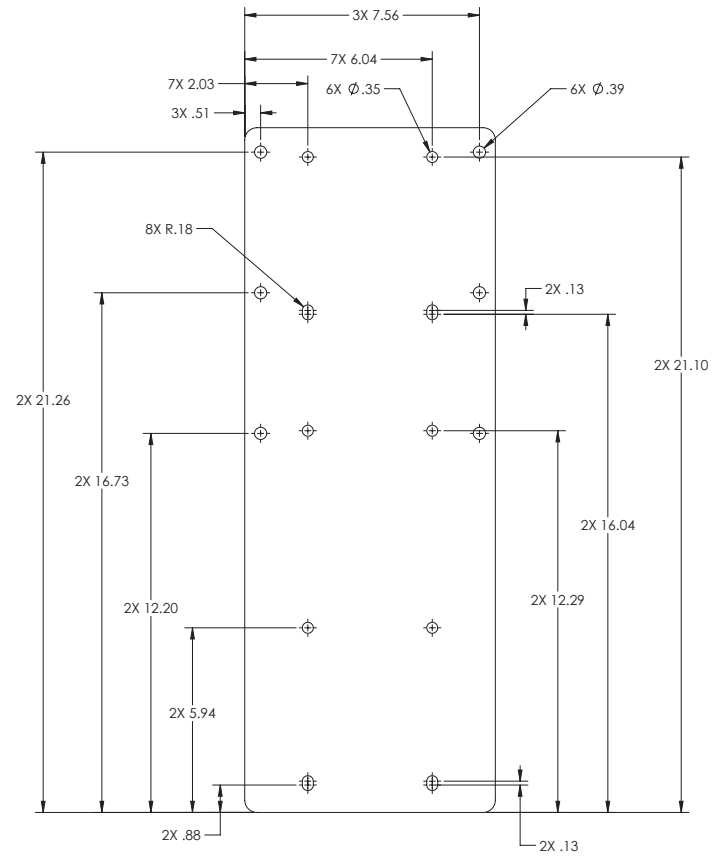
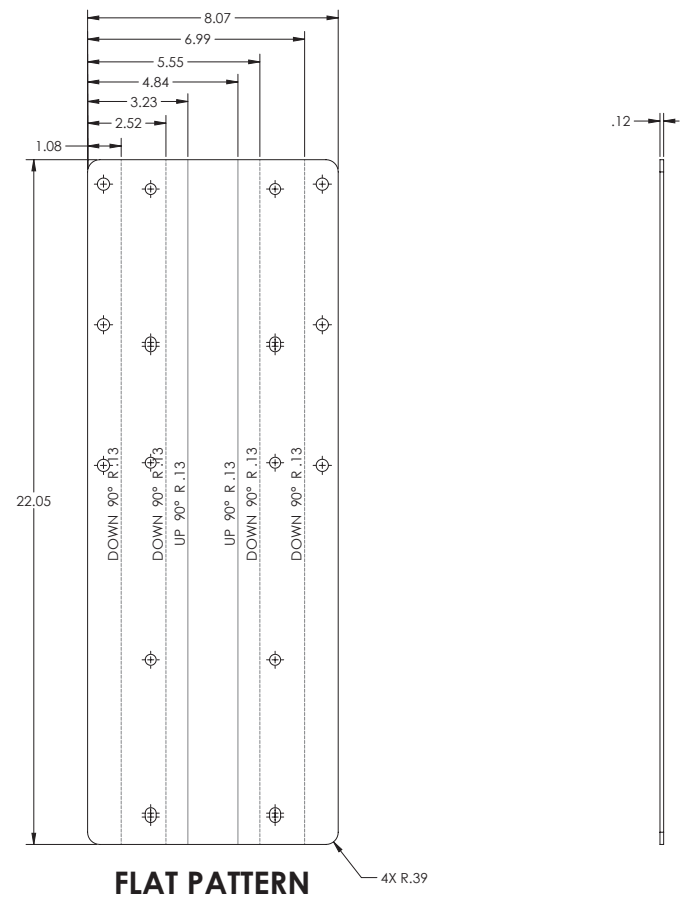

7. PART SHALL BE PACKAGED TO PREVENT DAMAGE DURING SHIPPING. PART SHALL ALSO BE PACKAGED WITH THE FOLLOWING HARDWARE:
- QUANTITY OF 8 M8 304 STAINLESS STEEL, PAN HEAD PHILLIPS MACHINE SCREW, LENGTH OF 20 MM, WITH WHITE FINISH.
 - QUANTITY OF 8 M8 GENERAL PURPOSE WASHERS, WITH WHITE FINISH.
 - QUANTITY OF 8 M8 SPLIT LOCK WASHERS, WITH WHITE FINISH.

⑥ M8 ZINC PLATED STAINLESS STEEL PRESS IN NUT TO BE INSERTED ON THE INSIDE BEND OF PART PRIOR TO COATING.

- 5. PART TO BE FREE OF BURRS AND SHARP EDGES.
- 4. USE MINIMAL BEND RADIUS AND TEAR RELIEFS UNLESS OTHERWISE SPECIFIED.
- 3. DIMENSIONS ARE SHOWN FOR INSPECTION PURPOSES ONLY. PART SHALL BE PRODUCED PER JBL SUPPLIED 3D STEP FILE 5078884.STEP.

2. FINISH:
- 5 STAGE IRON PHOSPHATE CONVERSION WASH PRIOR TO POWDER COAT.
 - POWDER COAT TO BE AKZONOBEL GTJA-14961A-C WHITE POLYESTER, 0.6mm (0.002 in) THICK.
 - CLEAR ZINC PER ASTM B633 TYPE V SC2.

1. MATERIAL: .118 IN. (3 MM) THICK ASTM A10088 SS GRADE 40 STEEL OR SPCC PER JIS G3141 STEEL.

NOTES: (UNLESS OTHERWISE SPECIFIED)

	TOLERANCES UNLESS OTHERWISE SPECIFIED INCHES: 0.0005 ± 0.0005" MILLIMETERS: 0.000 ± 0.1mm 0.001 ± 0.021" 0.002 ± 0.02 mm FRACTIONAL: ± 1/32 ANGLAR: ± 0.5° BREAK ALL SHARP EDGES (CROSS) INSPECTION DIMENSION		HARMAN JBL Professional 8500 Balboa Blvd Northridge, CA 91329 USA
	DIMENSIONS SHOWN ARE FOR REFERENCE AND INSPECTION ONLY. REFER TO 3D MODEL PROVIDED WITH THIS DRAWING FOR OVERALL DEFINITION OF PART GEOMETRY.	DRAWN BY: M. NIETO DATE: 7/26/2016	
RESTRICTION OF HAZARDOUS SUBSTANCES ALL MATERIALS USED IN THIS PART MUST BE ROHS COMPLIANT SUPPLIER SHALL PROVIDE A CERTIFICATE OF ROHS COMPLIANT WITH THE FIRST ARTICLE	ENGINEER: M. NIETO DATE: 7/25/2016	SIZE: D PART NO.: 5080556 SCALE: 1:2	REV: A SHEET 1 OF 2

8 | 7 | 6 | 5 | 4 | 3 | 2 | 1

8 | 7 | 6 | 5 | 4 | 3 | 2 | 1

THESE DRAWINGS AND SPECIFICATIONS ARE THE PROPERTY OF HARMAN. DO NOT DISCLOSE, REPRODUCE OR PUBLISH WITHOUT WRITTEN HARMAN APPROVAL.

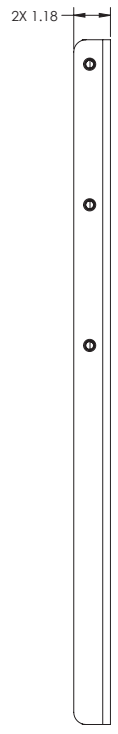
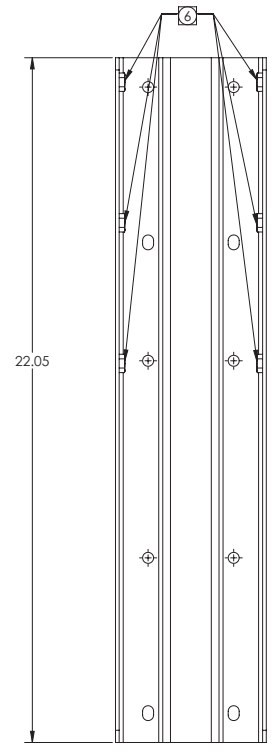
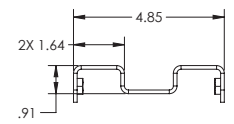

FOLDED PATTERN

8 | 7 | 6 | 5 | 4 | 3 | 2 | 1

HARMAN		JBL Professional 8500 Balboa Blvd Northridge, CA 91329 USA
TITLE WHITE SPLICER BRACKET		
SIZE D	PART NO. 5080556	REV A
SCALE: 1:1		SHEET 2 OF 2

THESE DRAWINGS AND SPECIFICATIONS ARE THE PROPERTY OF HARMAN. DO NOT DISCLOSE, REPRODUCE OR PUBLISH WITHOUT WRITTEN HARMAN APPROVAL.	
PART NUMBER	DESCRIPTION
5078938	TILT AND PAN BRACKET ASSEMBLY, BLACK, CBT1000
5078980	TILT AND PAN BRACKET ASSEMBLY, WHITE, CBT1000

REVISION HISTORY				
REV.	DESCRIPTION	ZONE	DATE	BY
A	INITIAL RELEASE		8/18/2016	MN
B	CORRECT THE AMOUNT OF HARDWARE		10/19/2016	MN

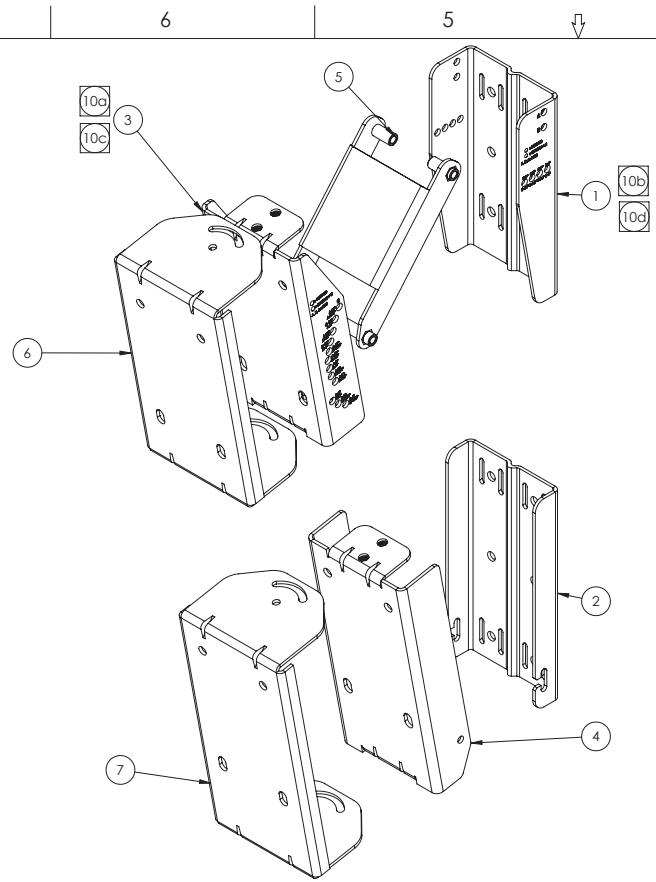

TABLE 1

ITEM NO.	DESCRIPTION	COMMENTS	QTY
1	TOP WALL BRACKET		1
2	BOTTOM WALL BRACKET		1
3	TOP TILT SPEAKER BRACKET		1
4	BOTTOM TILT SPEAKER BRACKET		1
5	ARM LINK		1
6	TOP PAN BRACKET		1
7	BOTTOM PAN BRACKET		1
8	M6, 304 STAINLESS STEEL PAN HEAD PHILLIPS MACHINE SCREW, 115 MM LENGTH, BLACK OXIDE FINISH	NOT SHOWN	1
9	M6, 304 STAINLESS STEEL PAN HEAD PHILLIPS MACHINE SCREW, 125 MM LENGTH, BLACK OXIDE FINISH	NOT SHOWN	2
10	M6, 304 STAINLESS STEEL BUTTON HEAD SOCKET CAP SCREWS, 20 MM LENGTH, BLACK OXIDE FINISH	NOT SHOWN	8
11	M8, 304 STAINLESS STEEL PAN HEAD PHILLIPS MACHINE SCREW, 20 MM LENGTH, BLACK OXIDE FINISH	NOT SHOWN	8
12	M6, 304 STAINLESS STEEL GENERAL PURPOSE WASHERS, 2 MM THICKNESS, BLACK OXIDE FINISH	NOT SHOWN	14
13	M6, 304 STAINLESS STEEL SPLIT LOCK WASHER, 2 MM THICK, BLACK OXIDE FINISH	NOT SHOWN	14
14	M6, RUBBER WASHER, 2MM THICK, OD 15MM, BLACK	NOT SHOWN	8
15	M8, 304 STAINLESS STEEL GENERAL PURPOSE WASHER, 2 MM THICK, BLACK OXIDE FINISH	NOT SHOWN	8
16	M6, 304 STAINLESS STEEL CAP NUT, BLACK OXIDE FINISH	NOT SHOWN	3
17	L-KEY ALLEN WRENCH, HEX SIZE 4 MM, SHORT LEG: .875 IN. X LONG LEG: 2.75 IN.	NOT SHOWN	1
18	M8, 304 STAINLESS STEEL SPLIT LOCK WASHER, 2 MM THICK, BLACK OXIDE FINISH	NOT SHOWN	8

10 ARTWORK SHOWN ON THIS DRAWING IS FOR REFERENCE ONLY. PART SHALL BE PRODUCED PER JBL SUPPLIED ARTWORK AS FOLLOWS:
a. DOCUMENT NO. 1000290619 FOR PART NUMBER 5078938
b. DOCUMENT NO. 1000290621 FOR PART NUMBER 5078938
c. DOCUMENT NO. 1000290622 FOR PART NUMBER 5078980
d. DOCUMENT NO. 1000290623 FOR PART NUMBER 5078980

- 11 FLAT PATTERNS DIMENSIONS ARE FOR REFERENCE ONLY. ALL BENDS HAVE A K-FACTOR OF 0.5.
- 8. ALL PARTS ARE TO BE PACKAGED TO PREVENT DAMAGE.
- 12 SEE TABLE 1 FOR HARDWARE EQUIPMENT.
- 13 M8 ZINC PLATED STAINLESS STEEL PRESS IN NUT TO BE INSERTED ON THE INSIDE BEND OF PART PRIOR TO COATING.
- 5. PART TO BE FREE OF BURRS AND SHARP EDGES.
- 4. USE MINIMAL BEND RADIUS AND TEAR RELIEFS UNLESS OTHERWISE SPECIFIED.
- 3. DIMENSIONS ARE SHOWN FOR INSPECTION PURPOSES ONLY. PART SHALL BE PRODUCED PER JBL SUPPLIED 3D STEP FILE 1000290318B.STEP.

14 FINISH - CLEAR ZINC PER ASTM B633 TYPE V SC2.
a. POWDER COAT TO BE AKZONOBEL GTJN-14962A-C BLACK POLYESTER, 0,6 MM (0,002 IN) THICK.
b. POWDER COAT TO BE AKZONOBEL GTJA-14961A-C WHITE POLYESTER, 0,6 MM (0,002 IN) THICK.
POWDER COAT SHOULD BE APPLIED TO COMPLY WITH CROSS HATCH ADHESION D3359B 4B.

1. MATERIAL: .118 IN. (3 MM) THICK ASTM A1008 SS GRADE 40 STEEL OR SPCC PER JIS G3141 STEEL.

NOTES: (UNLESS OTHERWISE SPECIFIED)

	TOLERANCES UNLESS OTHERWISE SPECIFIED INCHES: 0.000 + 0.005 MILLIMETERS: 0.000 + 0.1mm 0.001 + 0.021 0.002 + 0.022 0.003 + 0.5 mm	HARMAN JBL Professional 8500 Balboa Blvd Northridge, CA 91329 USA
	DIMENSIONS SHOWN ARE FOR REFERENCE AND INSPECTION ONLY. REFER TO 3D MODEL PROVIDED WITH THIS DRAWING FOR OVERALL DEFINITION OF PART GEOMETRY.	
RESTRICTION OF HAZARDOUS SUBSTANCES ALL MATERIALS USED IN THIS PART MUST BE ROHS COMPLIANT SUPPLIER SHALL PROVIDE A CERTIFICATE OF ROHS COMPLIANT WITH THE FIRST ARTICLE	ANGULAR: ±0.5° BREAK ALL SHARP EDGES INSPECTION DIMENSION	TITLE: TILT AND PAN BRACKET ASSEMBLY, CBT1000 PART NO.: 1000290318 REV: B SCALE: 1:2 SHEET 1 OF 10
DESIGNED BY: M. NIETO DATE: 8/17/2016 ENGINEER: M. NIETO DATE: 7/13/2016	DRAWN BY: M. NIETO DATE: 8/17/2016 ENGINEER: M. NIETO DATE: 7/13/2016	ZONE: D SIZE: 1000290318 REV: B

THESE DRAWINGS AND SPECIFICATIONS ARE THE PROPERTY OF HARMAN.
DO NOT DISCLOSE, REPRODUCE OR PUBLISH WITHOUT WRITTEN
HARMAN APPROVAL.

ITEM 1 - TOP WALL BRACKET

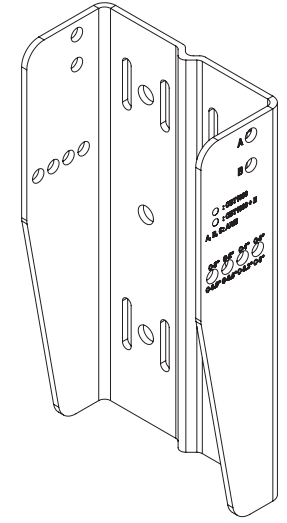
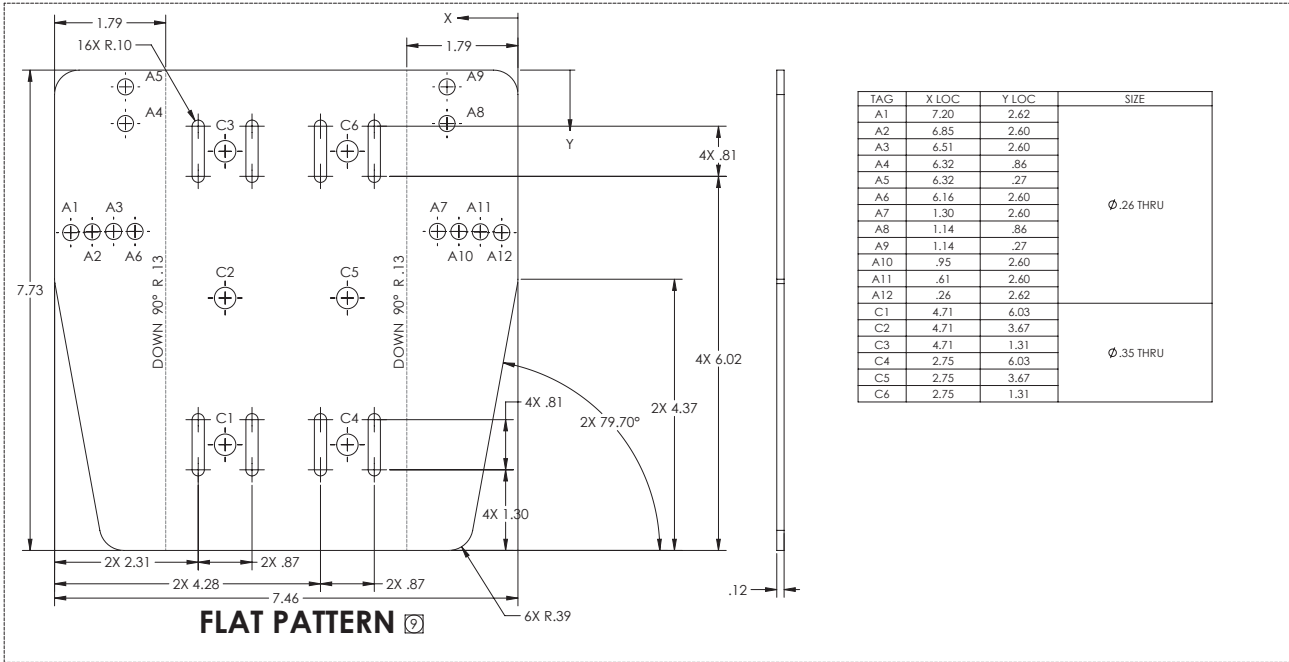

FLAT PATTERN [Symbol]

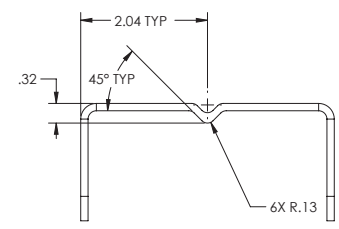
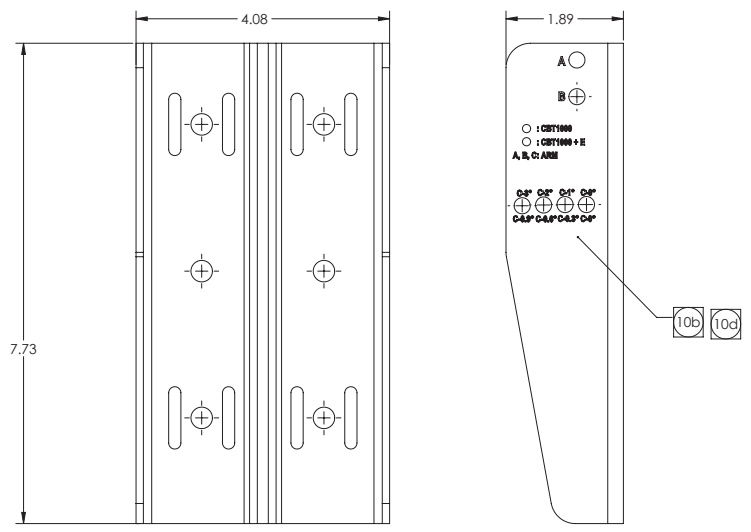

TOP VIEW

HARMAN		JBL Professional 8500 Balboa Blvd Northridge, CA 91329 USA	
TITLE TILT AND PAN BRACKET ASSEMBLY, CBT1000			
SIZE D	PART NO. 1000290318	REV B	
SCALE: 1:1		SHEET 2 OF 10	

8 | 7 | 6 | 5 | 4 | 3 | 2 | 1

THESE DRAWINGS AND SPECIFICATIONS ARE THE PROPERTY OF HARMAN. DO NOT DISCLOSE, REPRODUCE OR PUBLISH WITHOUT WRITTEN HARMAN APPROVAL.

ITEM 2 - BOTTOM WALL BRACKET

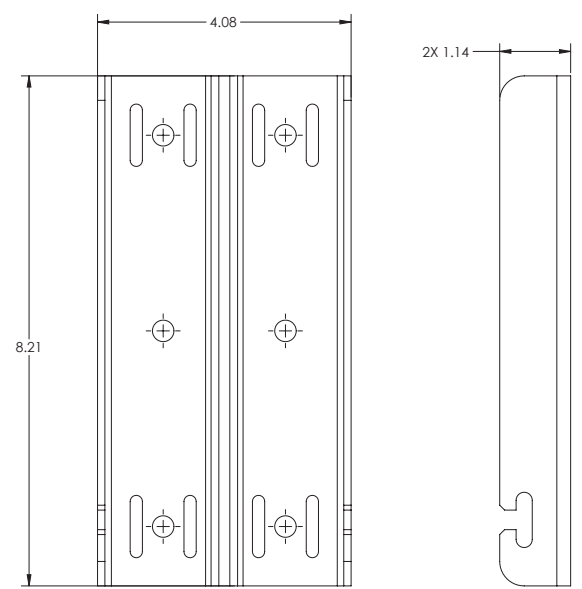
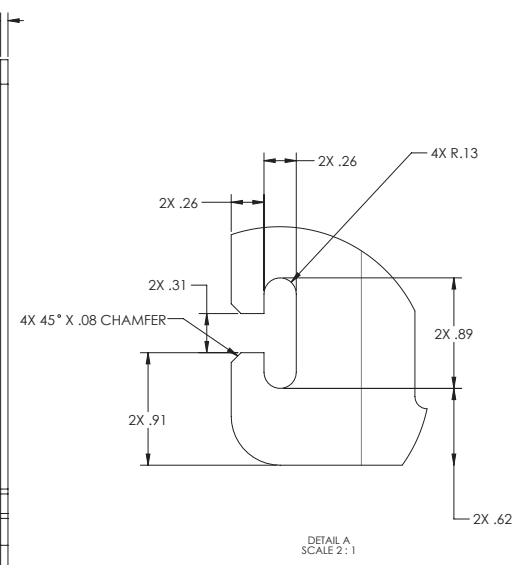
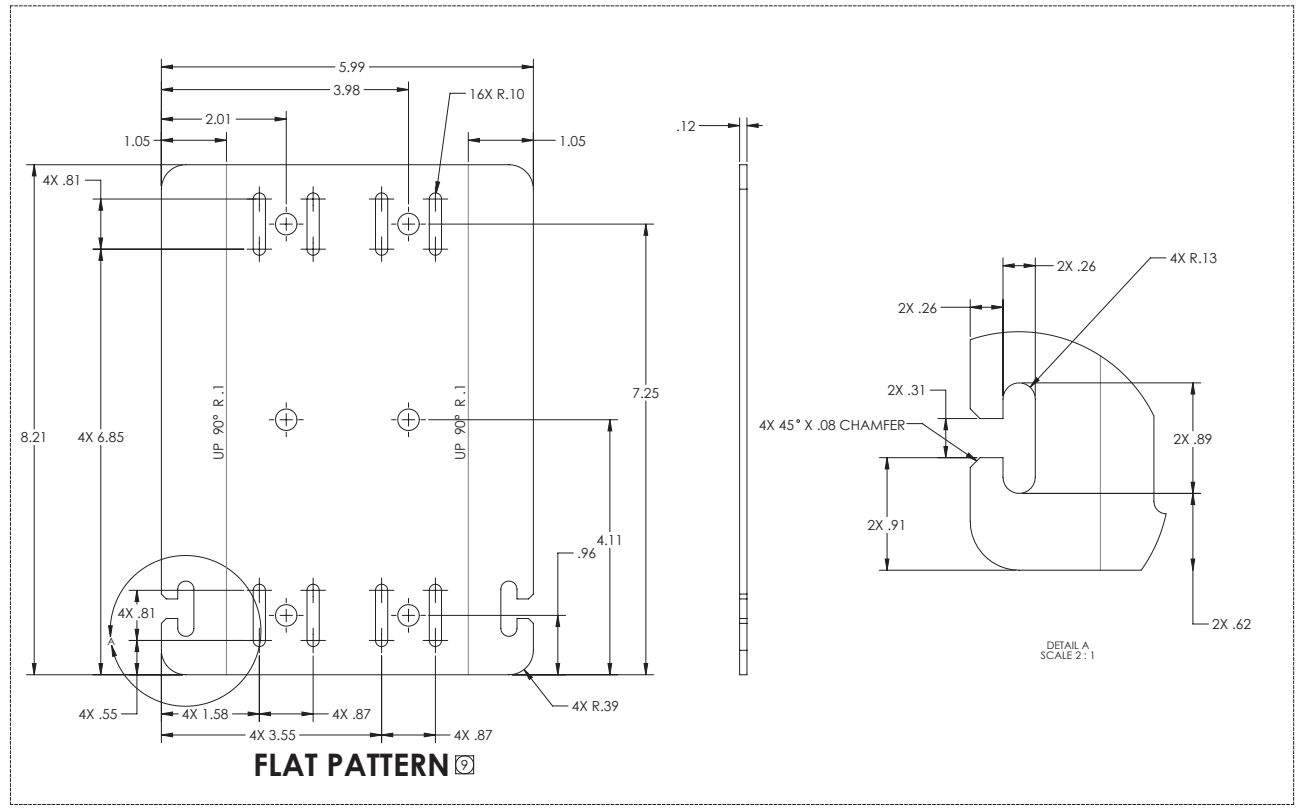

8 | 7 | 6 | 5 | 4 | 3 | 2 | 1

HARMAN		JBL Professional 8500 Balboa Blvd Northridge, CA 91329 USA	
TITLE TILT AND PAN BRACKET ASSEMBLY, CBT1000			
SIZE D	PART NO. 1000290318	REV B	
SCALE: 1:1		SHEET 3 OF 10	

8

7

6

5

↓

4

3

2

1

THESE DRAWINGS AND SPECIFICATIONS ARE THE PROPERTY OF HARMAN. DO NOT DISCLOSE, REPRODUCE OR PUBLISH WITHOUT WRITTEN HARMAN APPROVAL.

ITEM 3 - TOP TILT SPEAKER BRACKET

TAG	X LOC	Y LOC	SIZE
A1	.24	5.14	Ø .28 THRU
A2	.49	4.79	Ø .28 THRU
A3	.67	4.38	Ø .28 THRU
A4	.68	1.17	Ø .28 THRU
A5	.84	4.04	Ø .28 THRU
A6	.93	2.36	Ø .28 THRU
A7	.97	3.71	Ø .28 THRU
A8	.98	1.41	Ø .28 THRU
A9	1.06	2.71	Ø .28 THRU
A10	1.08	3.04	Ø .28 THRU
A11	1.08	3.40	Ø .28 THRU
A12	1.19	1.69	Ø .28 THRU
A13	6.24	1.69	Ø .28 THRU
A14	6.35	3.40	Ø .28 THRU
A15	6.35	3.04	Ø .28 THRU
A16	6.37	2.71	Ø .28 THRU
A17	6.45	1.41	Ø .28 THRU
A18	6.46	3.71	Ø .28 THRU
A19	6.50	2.36	Ø .28 THRU
A20	6.59	4.04	Ø .28 THRU
A21	6.75	1.17	Ø .28 THRU
A22	6.76	4.38	Ø .28 THRU
A23	6.94	4.79	Ø .28 THRU
A24	7.19	5.14	Ø .28 THRU
C1	2.34	6.77	Ø .35 THRU
C2	5.09	6.77	Ø .35 THRU
D1	3.71	-1.14	Ø .35 THRU
D2	3.71	-.27	Ø .35 THRU
D3	3.71	8.47	Ø .35 THRU
D4	3.71	9.34	Ø .35 THRU

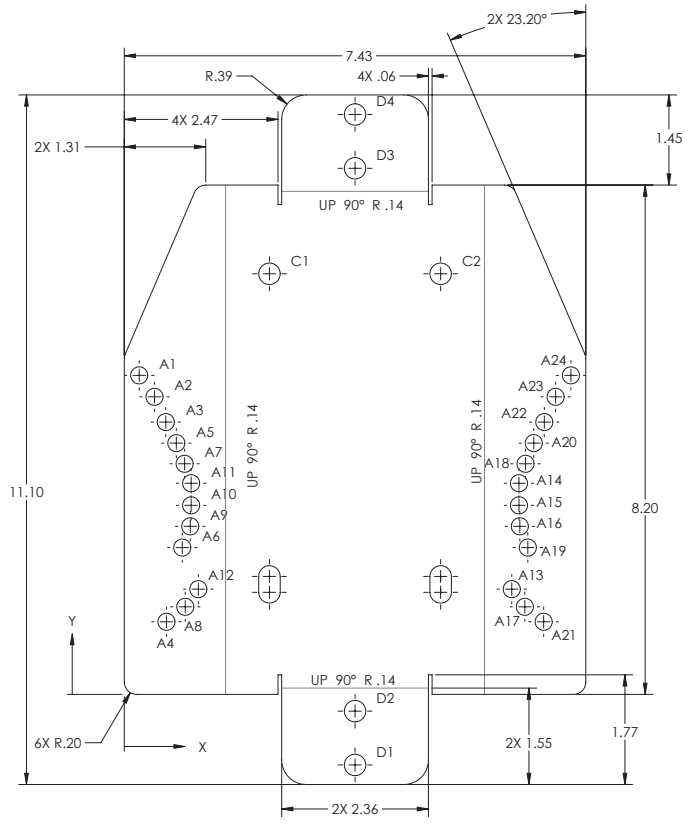

FLAT PATTERN ⑨

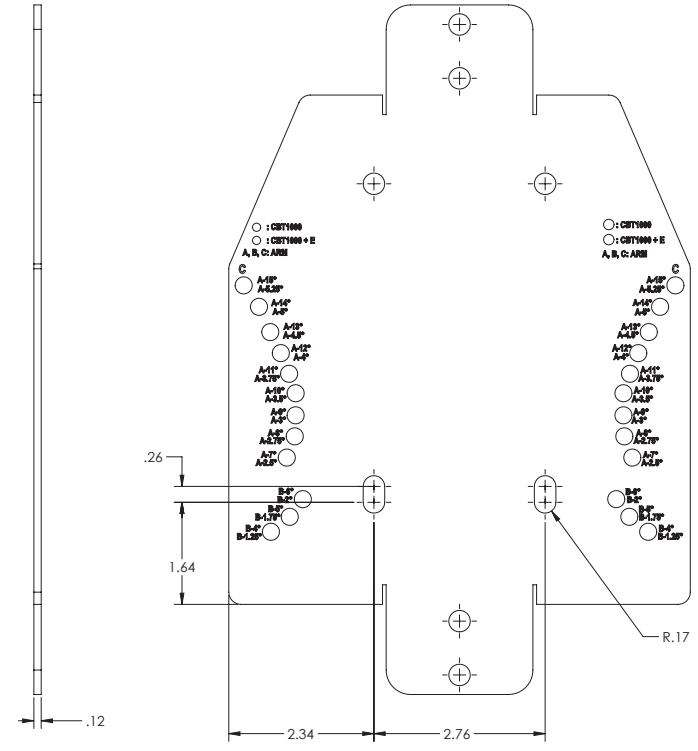

HARMAN		JBL Professional 8500 Balboa Blvd Northridge, CA 91329 USA	
TITLE TILT AND PAN BRACKET ASSEMBLY, CBT1000			
SIZE D	PART NO. 1000290318	REV B	
SCALE: 1:1		SHEET 4 OF 10	

8

7

6

5

↑

4

3

2

1

8 | 7 | 6 | 5 | 4 | 3 | 2 | 1

THESE DRAWINGS AND SPECIFICATIONS ARE THE PROPERTY OF HARMAN.
DO NOT DISCLOSE, REPRODUCE OR PUBLISH WITHOUT WRITTEN
HARMAN APPROVAL.

ITEM 3 - TOP TILT SPEAKER BRACKET

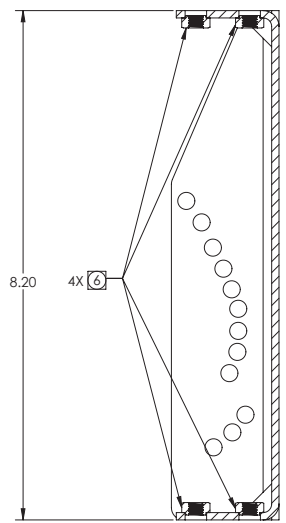
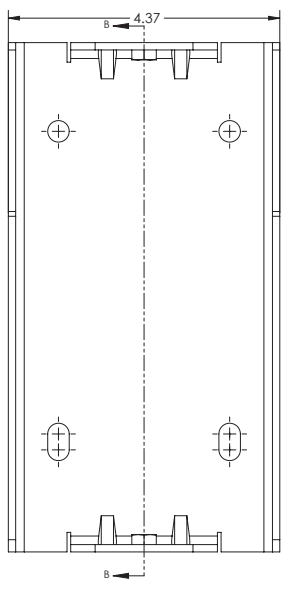
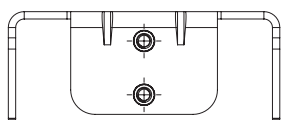

SECTION B-B

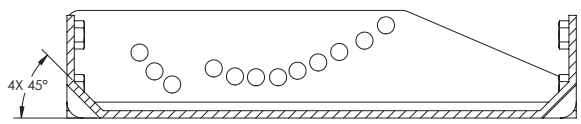
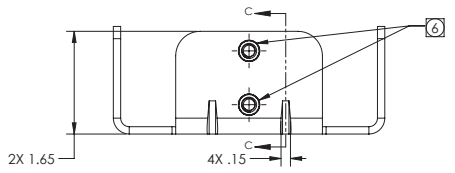
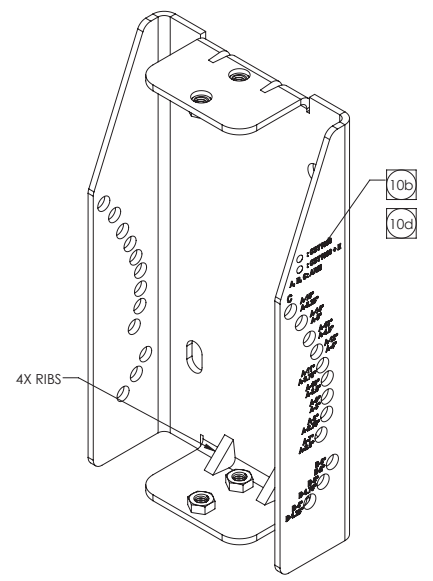
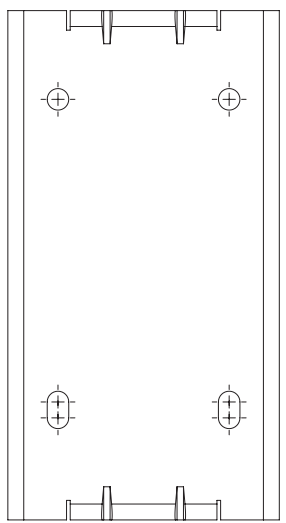

SECTION C-C

HARMAN		JBL Professional 8500 Balboa Blvd Northridge, CA 91329 USA	
TITLE TILT AND PAN BRACKET ASSEMBLY, CBT1000			
SIZE D	PART NO. 1000290318	REV B	
SCALE: 1:1		SHEET 5 OF 10	

8 | 7 | 6 | 5 | 4 | 3 | 2 | 1

8 7 6 5 4 3 2 1

THESE DRAWINGS AND SPECIFICATIONS ARE THE PROPERTY OF HARMAN. DO NOT DISCLOSE, REPRODUCE OR PUBLISH WITHOUT WRITTEN HARMAN APPROVAL.

ITEM 4 - BOTTOM TILT SPEAKER BRACKET

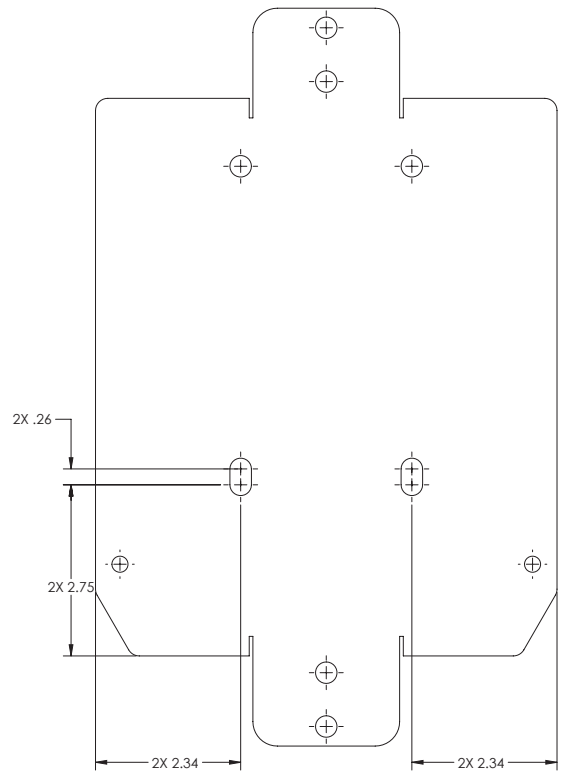
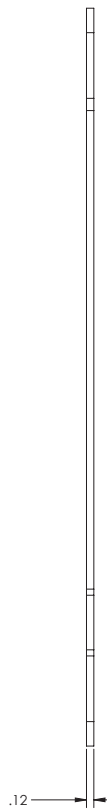
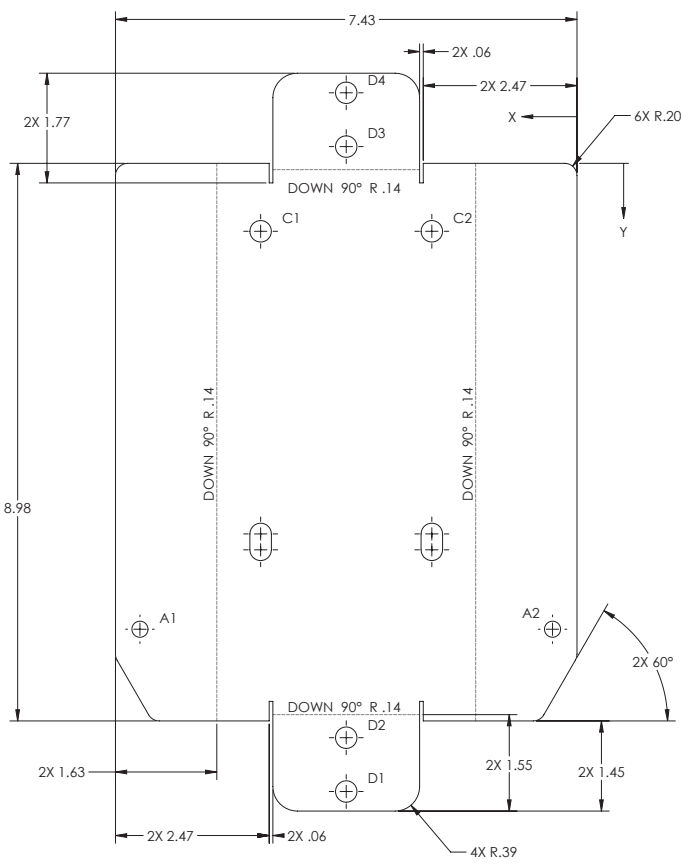

FLAT PATTERN

TAG	X LOC	Y LOC	SIZE
A1	7.04	7.50	Ø.26 THRU
A2	.39	7.50	Ø.26 THRU
C1	5.09	1.09	Ø.35 THRU
C2	2.34	1.09	Ø.35 THRU
D1	3.71	10.11	Ø.35 THRU
D2	3.71	9.25	Ø.35 THRU
D3	3.71	-.27	Ø.35 THRU
D4	3.71	-1.14	Ø.35 THRU

HARMAN		JBL Professional 8500 Balboa Blvd Northridge, CA 91329 USA	
TITLE TILT AND PAN BRACKET ASSEMBLY, CBT1000			
SIZE D	PART NO. 1000290318	REV B	
SCALE: 1:1		SHEET 6 OF 10	

8 7 6 5 4 3 2 1

8

7

6

5

↓

4

3

2

1

THESE DRAWINGS AND SPECIFICATIONS ARE THE PROPERTY OF HARMAN. DO NOT DISCLOSE, REPRODUCE OR PUBLISH WITHOUT WRITTEN HARMAN APPROVAL.

ITEM 4 - BOTTOM TILT SPEAKER BRACKET

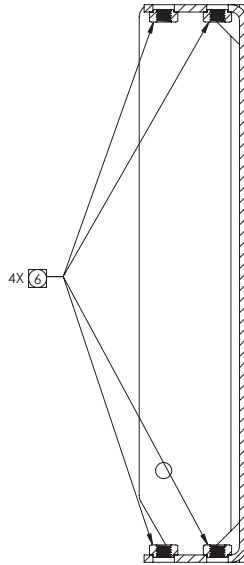
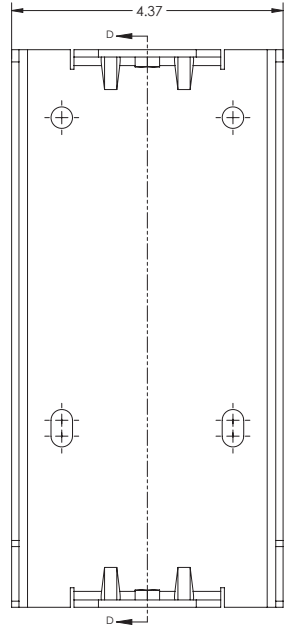
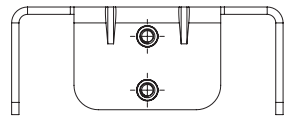

SECTION D-D

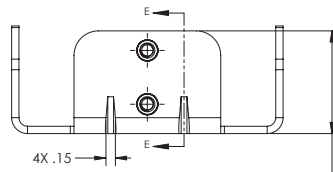
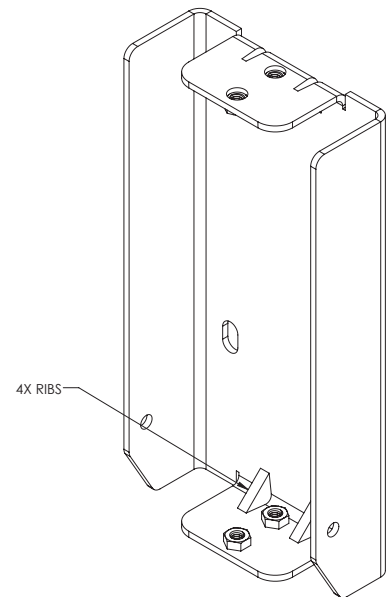
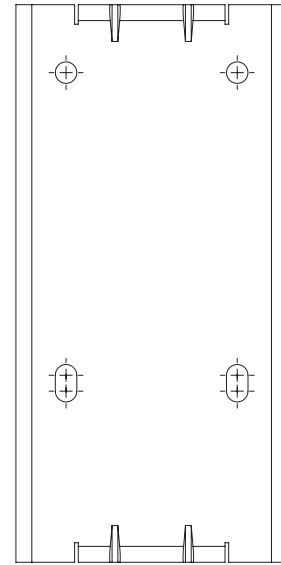

2X 1.65

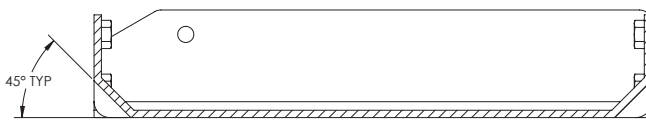

SECTION E-E

8

7

6

5

↑

4

3

2

1

HARMAN		JBL Professional 8500 Balboa Blvd Northridge, CA 91329 USA	
TITLE TILT AND PAN BRACKET ASSEMBLY, CBT1000			
SIZE D	PART NO. 1000290318	REV B	
SCALE: 1:1		SHEET 7 OF 10	

8 | 7 | 6 | 5 | 4 | 3 | 2 | 1

THESE DRAWINGS AND SPECIFICATIONS ARE THE PROPERTY OF HARMAN. DO NOT DISCLOSE, REPRODUCE OR PUBLISH WITHOUT WRITTEN HARMAN APPROVAL.

ITEM 5 - ARM LINK

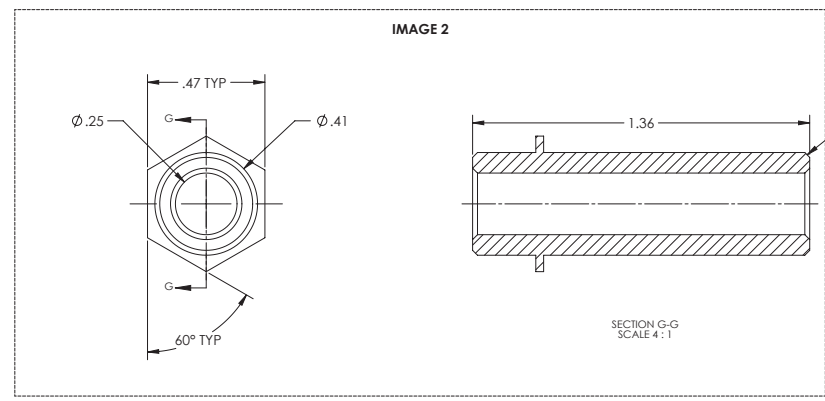
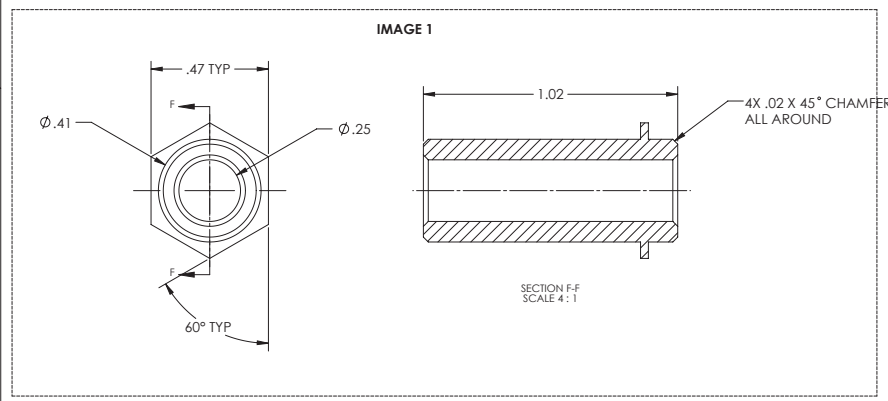
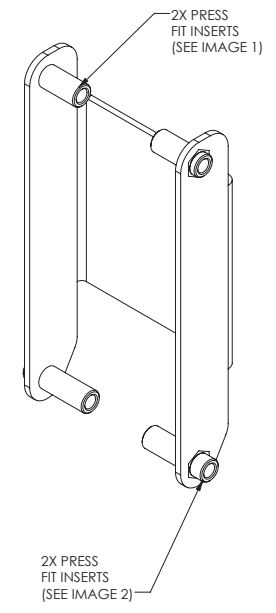
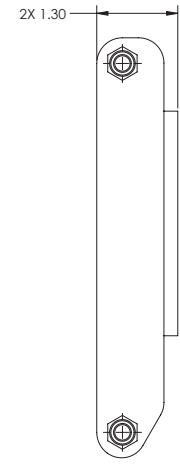
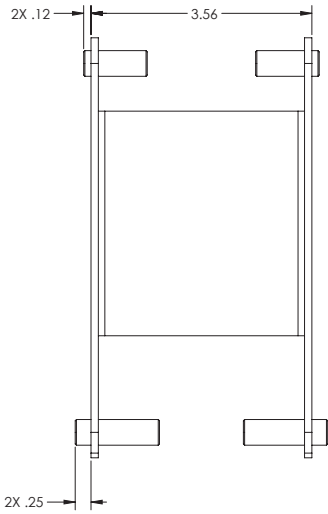
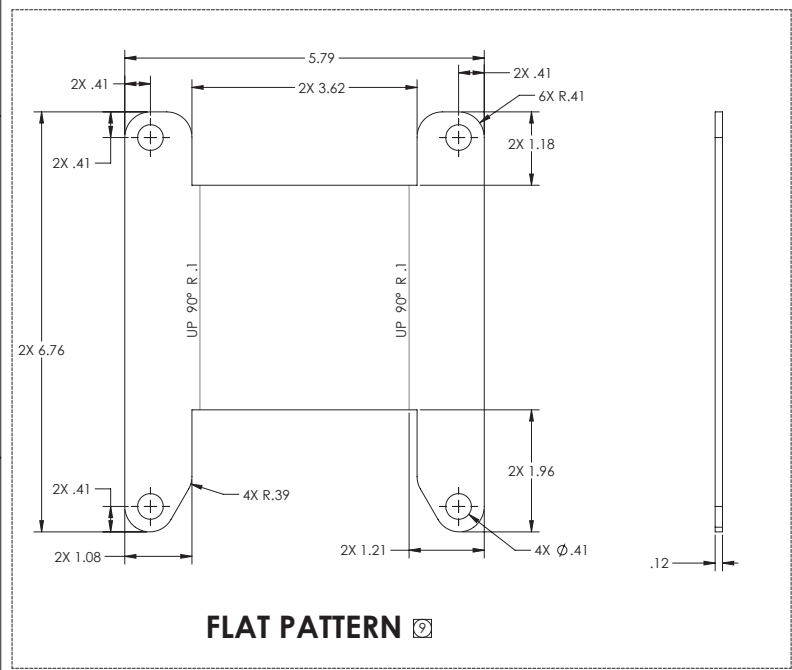

HARMAN		JBL Professional 8500 Balboa Blvd Northridge, CA 91329 USA	
TITLE TILT AND PAN BRACKET ASSEMBLY, CBT1000			
SIZE D	PART NO. 1000290318	REV B	
SCALE: 1:1		SHEET 8 OF 10	

8 | 7 | 6 | 5 | 4 | 3 | 2 | 1

THESE DRAWINGS AND SPECIFICATIONS ARE THE PROPERTY OF HARMAN.
DO NOT DISCLOSE, REPRODUCE OR PUBLISH WITHOUT WRITTEN
HARMAN APPROVAL.

ITEM 6 - TOP PAN BRACKET

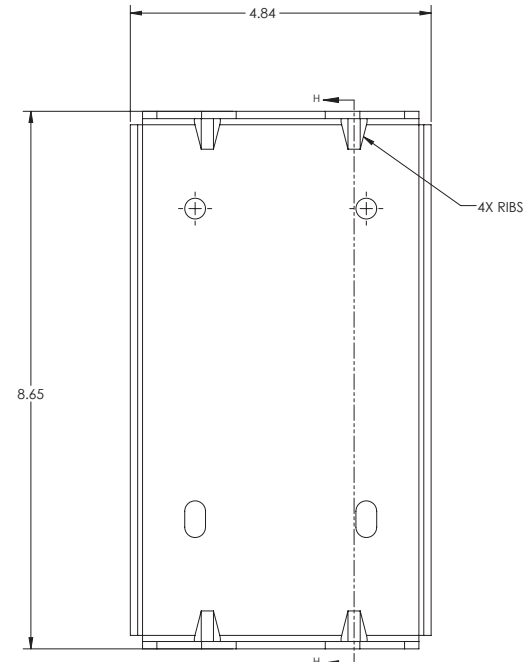
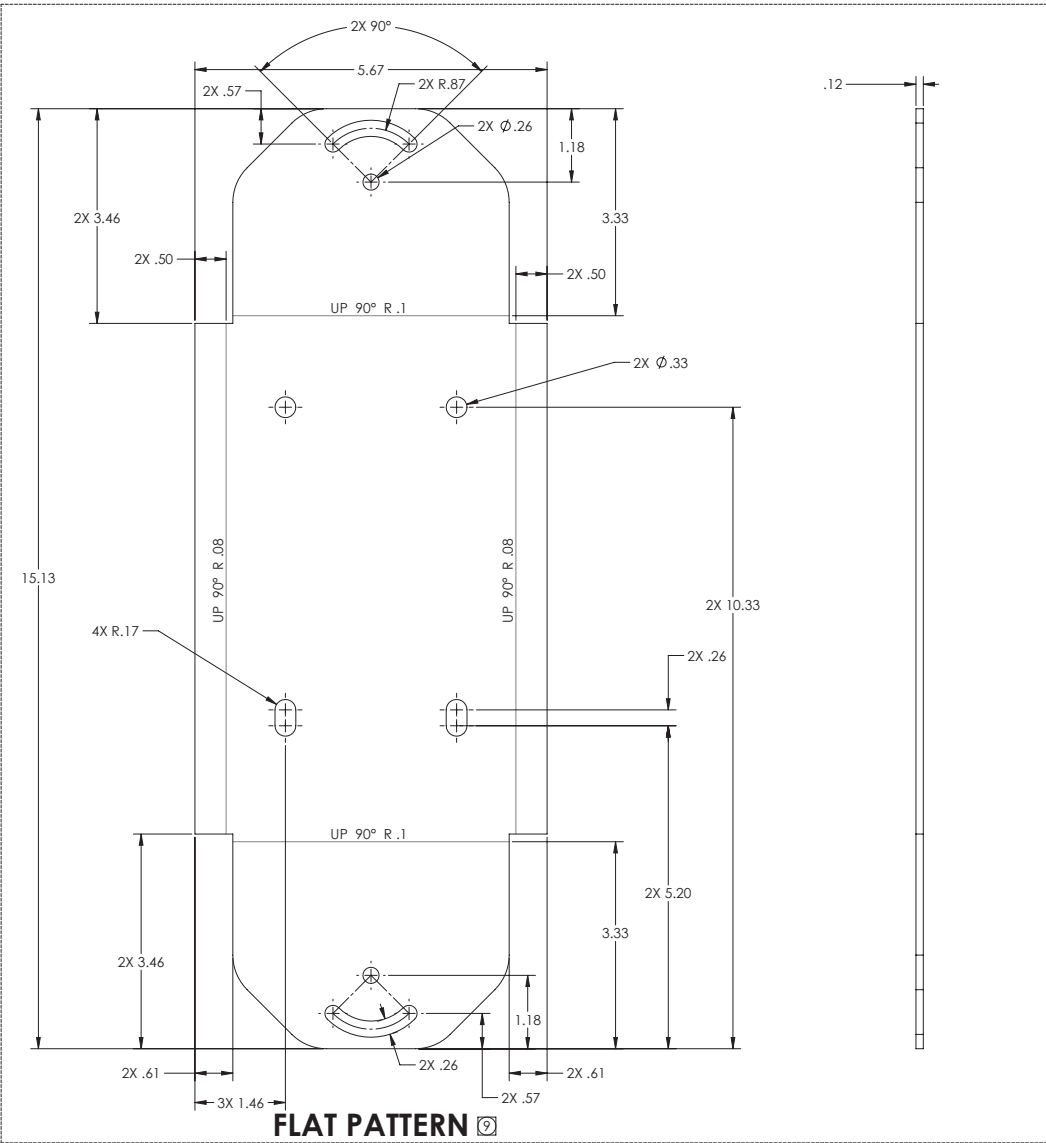

FOLDED

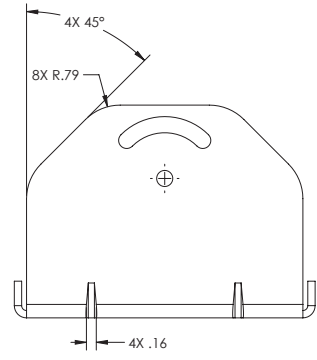

HARMAN		JBL Professional 8500 Balboa Blvd Northridge, CA 91329 USA	
TITLE TILT AND PAN BRACKET ASSEMBLY, CBT1000			
SIZE D	PART NO. 1000290318	REV B	
SCALE: 1:1		SHEET 9 OF 10	

THESE DRAWINGS AND SPECIFICATIONS ARE THE PROPERTY OF HARMAN. DO NOT DISCLOSE, REPRODUCE OR PUBLISH WITHOUT WRITTEN HARMAN APPROVAL.

ITEM 7 - BOTTOM PAN BRACKET

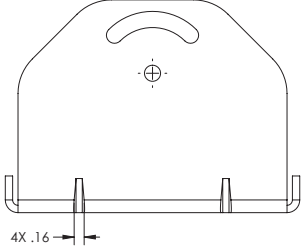
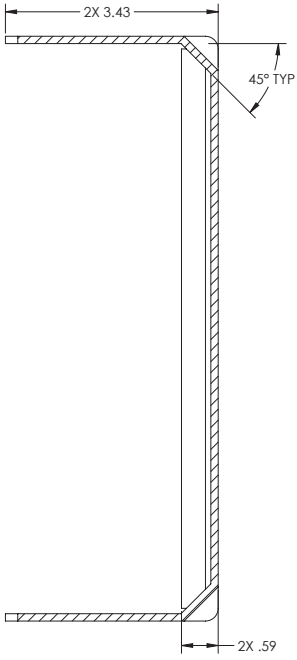
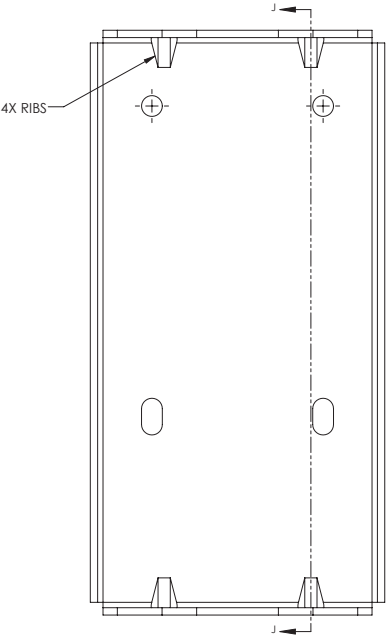
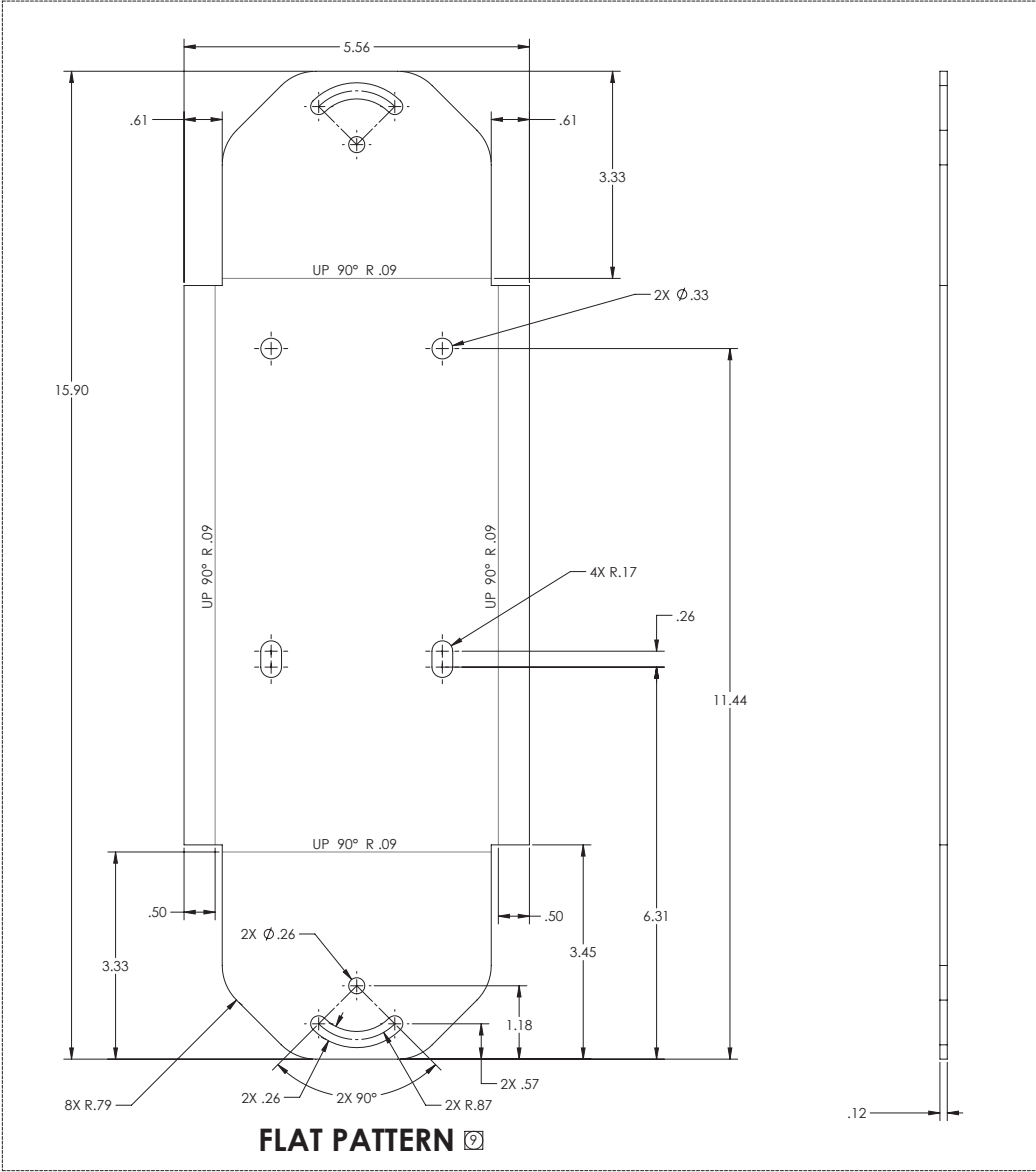

HARMAN		JBL Professional 8500 Balboa Blvd Northridge, CA 91329 USA	
TITLE TILT AND PAN BRACKET ASSEMBLY, CBT1000			
SIZE D	PART NO. 1000290318	REV B	
SCALE: 1:1		SHEET 10	OF 10

8 | 7 | 6 | 5 | 4 | 3 | 2 | 1

THESE DRAWINGS AND SPECIFICATIONS ARE THE PROPERTY OF HARMAN. DO NOT DISCLOSE, REPRODUCE OR PUBLISH WITHOUT WRITTEN HARMAN APPROVAL.

PART NUMBER	DESCRIPTION
5079871	CBT1K-ACC1, BLACK
5079872	CBT1K-ACC1-WH, WHITE

REVISION HISTORY				
REV.	DESCRIPTION	ZONE	DATE	BY
A	INITIAL RELEASE		9/9/2016	MN
B	CORRECTED NOTATION FOR HARDWARE PACKAGING		11/21/2016	MN
C	1000297491 SPEC SHEET TO BE REMOVED		1/3/2017	MN

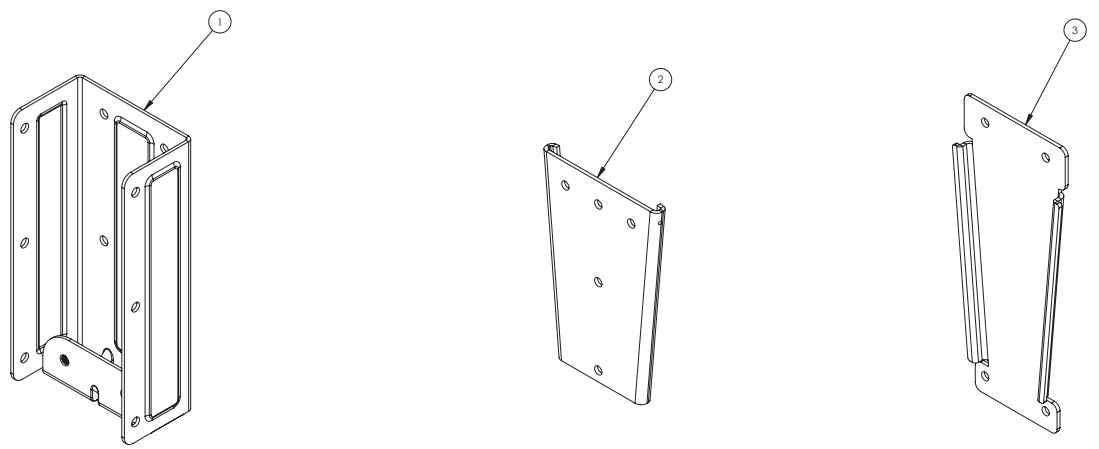

ITEM	QTY	PART NUMBER	DESCRIPTION
1	1	5078119	OFFSET BRACKET, BLACK
2	2	5077294	WALL BRACKET, BLACK, CBT-FM3
3	2	5077295	SPEAKER BRACKET, BLACK, CBT-FM3

ITEM	QTY	PART NUMBER	DESCRIPTION
1	1	5079876	OFFSET BRACKET, WHITE
2	2	5078200	SPEAKER BRACKET, WHITE, CBT-FM3
3	2	5078202	WALL BRACKET, WHITE, CBT-FM3

4. ADD THE FOLLOWING SPEC SHEETS KIT:
 • 1000297492 - SPEC SHEET FOR MTC-CBT-FM3.
3. ALL HARDWARE CORRESPONDING TO THE JBL PART NUMBER MUST BE PACKAGED INDIVIDUALLY. SEE PDF DRAWING OF JBL PART NUMBER FOR DETAILS.

2. PACKAGING WILL BE DETERMINED AS FOLLOW:
 a. CBT1K-ACC1: SEE TABLE 1
 b. CBT1K-ACC1-WH: SEE TABLE 2

1. ALL COMPONENTS SHALL BE PACKAGED TO PREVENT SCRACHES AND OTHER DAMAGES.

NOTES: (UNLESS OTHERWISE SPECIFIED)

THIRD ANGLE PROJECTION 	TOLERANCES UNLESS OTHERWISE SPECIFIED INCHES: 0.000 + 0.005 MILLIMETERS: 0.000 ± 0.1mm 0.001 ± 0.025 0.002 ± 0.050 FRACTIONAL ± 1/32 0.001 ± 0.025 0.002 ± 0.050		HARMAN JBL Professional 8500 Balboa Blvd Northridge, CA 91329 USA
	DIMENSIONS SHOWN ARE FOR REFERENCE AND INSPECTION ONLY. REFER TO 3D MODEL PROVIDED WITH THIS DRAWING FOR OVERALL DEFINITION OF PART GEOMETRY.		
RESTRICTION OF HAZARDOUS SUBSTANCES ALL MATERIALS USED IN THIS PART MUST BE ROHS COMPLIANT SUPPLIER SHALL PROVIDE A CERTIFICATE OF ROHS COMPLIANT WITH THE FIRST ARTICLE	DRAWN BY: M. NIETO DESIGNED BY: M. NIETO ENGINEER: M. NIETO	DATE: 9/9/2016 DATE: 6/15/2016	TITLE: CBT1K-ACC1-XX, CBT1000 SIZE: D DRAWING NO.: 1000292521 REV: C SCALE: 1:2 SHEET 1 OF 1

8 | 7 | 6 | 5 | 4 | 3 | 2 | 1

REVISIONS			
LTR	DESCRIPTION	DRFT	DATE
A	RELEASE TO MARKETING	MN	3/27/2017

THESE DRAWINGS AND SPECIFICATIONS ARE THE PROPERTY OF JBL INCORPORATED. THEY ARE ISSUED IN STRICT CONFIDENCE AND SHALL NOT BE REPRODUCED OR USED AS THE BASIS FOR MANUFACTURE OR APPARATUS WITHOUT WRITTEN PERMISSION.

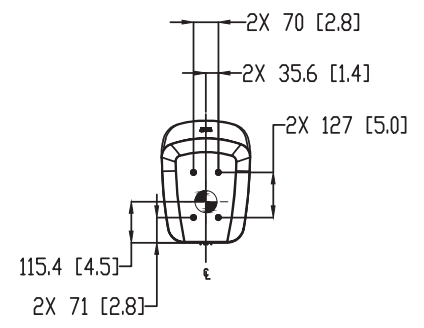
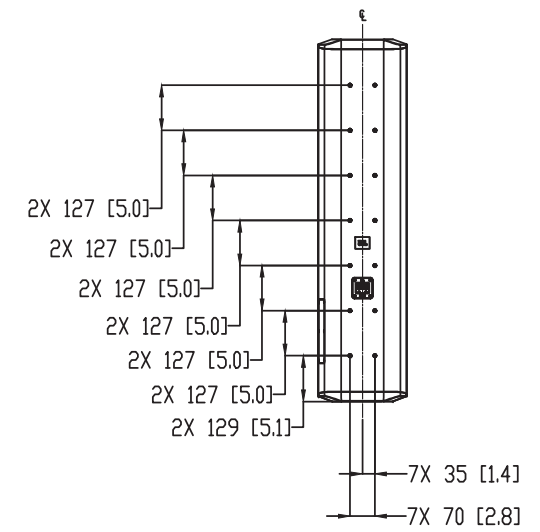
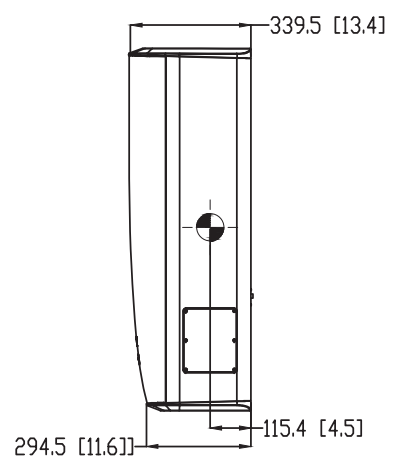
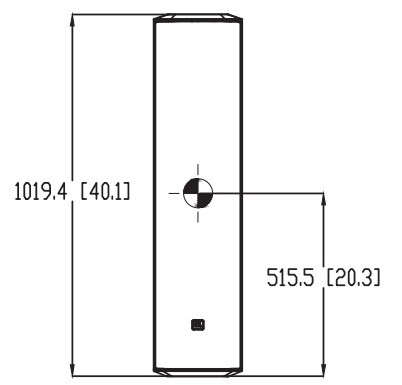
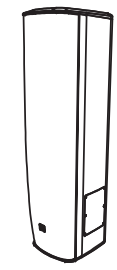
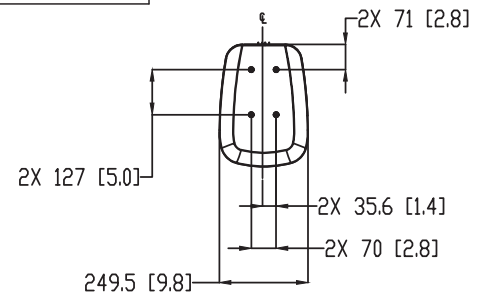

D
C
B
A

D
C
B
A

- COMPONENTS: LF - 6X 165 MM (6.5 IN), HF - 24X 25 MM (1 IN)
 - INPUT CONNECTORS: 2 POSITION TERMINAL STRIP LOCATED ON BACK
 - GRILL: 1.8 MM (0.07 IN) PERFORATED POWDER COATED BLACK OR WHITE WITH ACOUSTICAL BACKING
 - MATERIALS: BLACK OR WHITE ABS PLASTIC
 - FINISH: BLACK OR WHITE MATTE
 - SUSPENSION POINTS: 11X M8 SUSPENSION POINTS
 - WEIGHT: 24.5 kg (54 lbs)
- ☉ CENTER OF GRAVITY (CG)
- NOTES: (UNLESS OTHERWISE SPECIFIED)

TOLERANCES
(UNLESS OTHERWISE SPECIFIED)

.X.XX ± .063 INCH
.XX ± .125 INCH

ANGULAR TOLERANCE OF 0°±30'

FRACTIONAL DIMENSIONS ± 1/32

* DIMENSIONS ARE MM (INCHES)
* ALL DIMENSIONS ARE FINISHED DIMENSIONS
* DO NOT SCALE DRAWING

		JBL PROFESSIONAL A Harman International Company Northridge, California 91329 U.S.A.	
TITLE CUSTOMER DRAWING, CBT 1000			
SIZE A	DRAWING NO. 1000302920	REV A	
SCALE NTS	SHEET 1 OF 1		

4

3

2

1

4

3

2

1

THESE DRAWINGS AND SPECIFICATIONS ARE THE PROPERTY OF JBL INCORPORATED. THEY ARE ISSUED IN STRICT CONFIDENCE AND SHALL NOT BE REPRODUCED OR USED AS THE BASIS FOR MANUFACTURE OR APPARATUS WITHOUT WRITTEN PERMISSION.

REVISIONS			
LTR	DESCRIPTION	DFT	DATE
A	RELEASE TO MARKETING	MN	4/3/2017

D

C

B

A

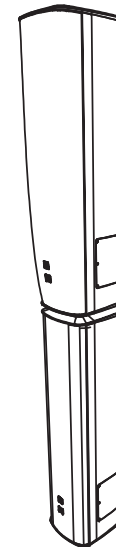
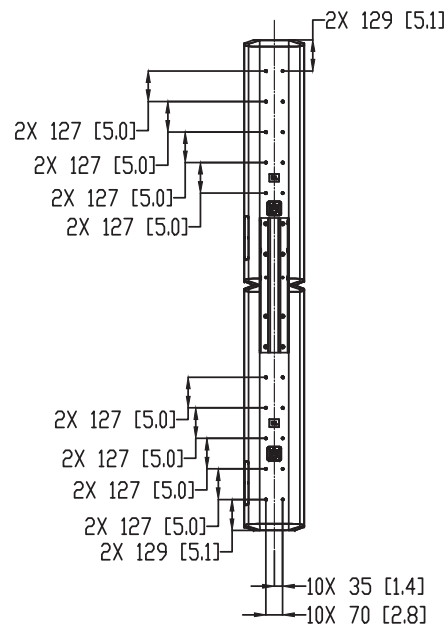
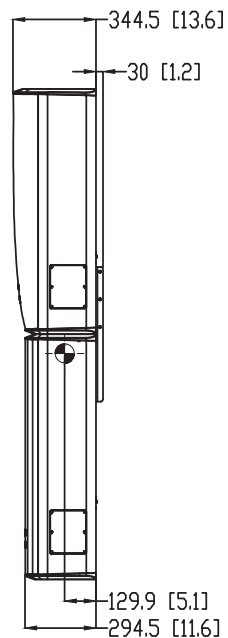
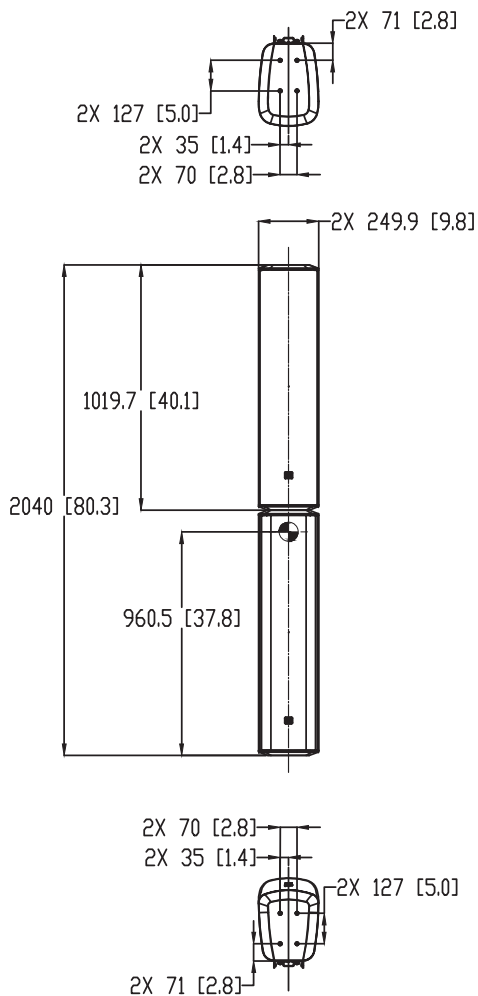

D

C

B

A

- COMPONENTS: CBT 1000: LF - 6X 165 MM (6.5 IN), HF - 24X 25MM (1")
CBT 1000E: LF - 6X 165 MM (6.5 IN)
- INPUT CONNECTORS: CBT 1000: 2 POSITION TERMINAL STRIP LOCATED ON BACK
CBT 1000E: 2 POSITION TERMINAL STRIP LOCATED ON BACK
- GRILL: 1.8 MM (0.07 IN) PERFORATED POWDER COATED BLACK OR WHITE WITH ACOUSTICAL BACKING
- MATERIALS: BLACK OR WHITE ABS PLASTIC
- FINISH: BLACK OR WHITE MATTE
- SUSPENSION POINTS: 28X M8 SUSPENSION POINTS
- WEIGHT: 47.2 KG (104 LBS) WITHOUT BRACKET. 49.7 KG (109.5 LBS) WITH BRACKET.

☒ CENTER OF GRAVITY (CG) ⊕

NOTES: (UNLESS OTHERWISE SPECIFIED)

TOLERANCES

(UNLESS OTHERWISE SPECIFIED)

.X.XX ± .063 INCH

.X.X ± .125 INCH

ANGULAR TOLERANCE OF 0°±30'

FRACTIONAL DIMENSIONS ± 1/32

* DIMENSIONS ARE MM (INCHES)

* ALL DIMENSIONS ARE FINISHED DIMENSIONS

* DO NOT SCALE DRAWING



JBL PROFESSIONAL
A Harman International Company
Northridge, California 91329 U.S.A.

TITLE
CUSTOMER DRAWING, CBT 1000 & 1000E

SIZE A	DRAWING NO. 1000302921	REV A
------------------	----------------------------------	-----------------

SCALE NTS	SHEET 1	OF 1
--------------	------------	---------

4

3

2

1

4

3

2

1

THESE DRAWINGS AND SPECIFICATIONS ARE THE PROPERTY OF JBL INCORPORATED. THEY ARE ISSUED IN STRICT CONFIDENCE AND SHALL NOT BE REPRODUCED OR USED AS THE BASIS FOR MANUFACTURE OR APPARATUS WITHOUT WRITTEN PERMISSION.

REVISIONS			
LTR	DESCRIPTION	DRFT	DATE
A	RELEASE TO MARKETING	MN	4/3/2017

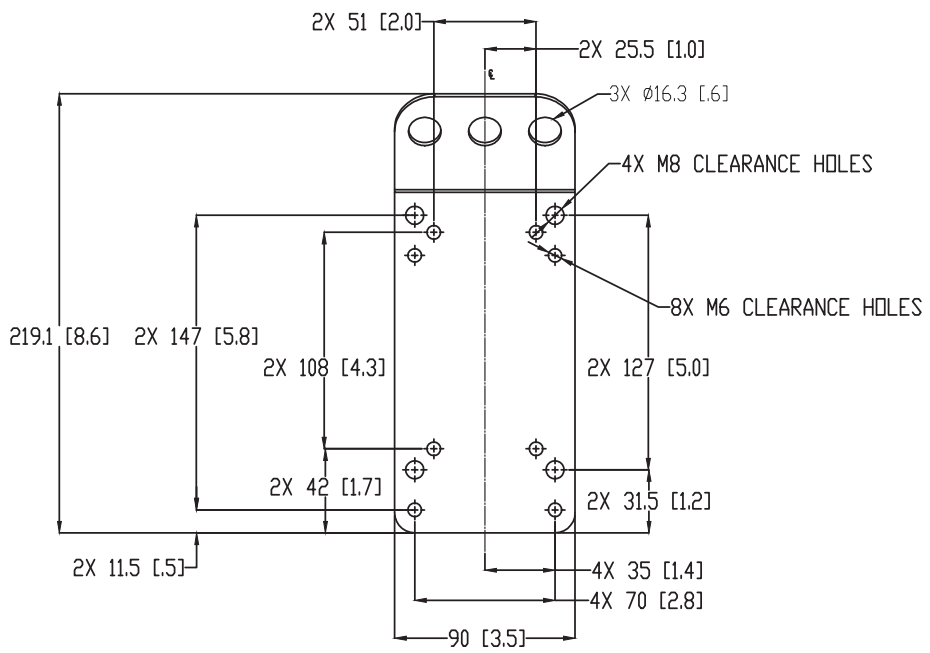

D

D

C

C

B

B

A

A

- COMPONENTS: N/A
 - INPUT CONNECTORS: N/A
 - GRILL: N/A
 - MATERIALS: 3 MM (.12 IN) THICK STEEL.
 - FINISH: POWDER COATED IN BLACK OR WHITE.
 - SUSPENSION POINTS: N/A.
 - WEIGHT: .22 KG (.5 LB)
- ⓐ CENTER OF GRAVITY (CG) ⊕
- NOTES: (UNLESS OTHERWISE SPECIFIED)

TOLERANCES
(UNLESS OTHERWISE SPECIFIED)

X.XX ± .063 INCH
XX ± .125 INCH

ANGULAR TOLERANCE OF 0°±30'

FRACTIONAL DIMENSIONS ± 1/32

* DIMENSIONS ARE MM (INCHES)
* ALL DIMENSIONS ARE FINISHED DIMENSIONS
* DO NOT SCALE DRAWING

		JBL PROFESSIONAL A Harman International Company Northridge, California 91329 U.S.A.	
TITLE CUSTOMER DRAWING, MTC-CBT-SUS3			
SIZE A	DRAWING NO. 1000303586	REV A	
SCALE NTS	SHEET 1 OF 1		

4

3

2

1

4

3

2

1

THESE DRAWINGS AND SPECIFICATIONS ARE THE PROPERTY OF JBL INCORPORATED. THEY ARE ISSUED IN STRICT CONFIDENCE AND SHALL NOT BE REPRODUCED OR USED AS THE BASIS FOR MANUFACTURE OR APPARATUS WITHOUT WRITTEN PERMISSION.

REVISIONS			
LTR	DESCRIPTION	DRFT	DATE
A	RELEASE TO MARKETING	MN	4/4/2017

D

D

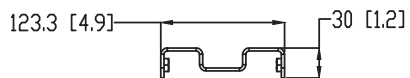

3X 17 [.7]
3X M8
THREADED INSERTS

3X 17 [.7]
3X M8
THREADED INSERTS

C

C

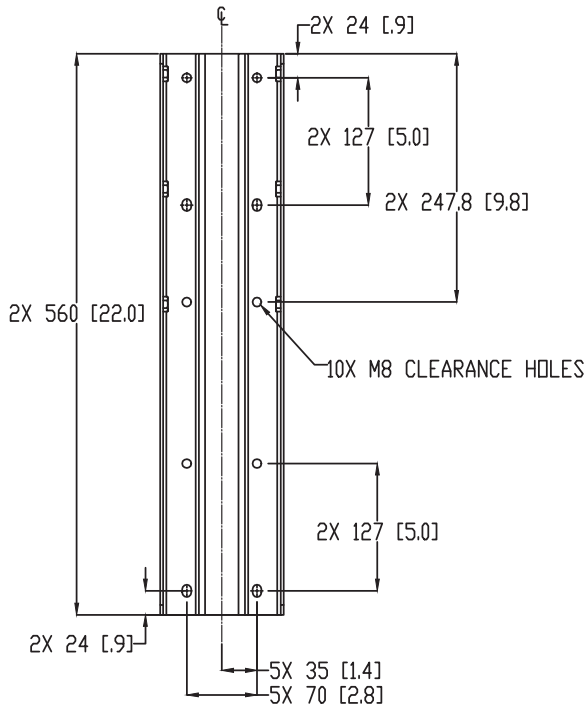

B

B

A

A

1. COMPONENTS: N/A
2. INPUT CONNECTORS: N/A
3. GRILL: N/A
4. MATERIALS: 3 MM (.12 IN) THICK STEEL.
5. FINISH: POWDER COATED BLACK OR WHITE.
6. SUSPENSION POINTS: N/A.
7. WEIGHT: 2.5 KG (5.5 LBS)

Ⓢ CENTER OF GRAVITY (CG) ⊕

NOTES: (UNLESS OTHERWISE SPECIFIED)

TOLERANCES (UNLESS OTHERWISE SPECIFIED)	
.XX	± .063 INCH
.XX	± .125 INCH
ANGULAR TOLERANCE OF 0°±30'	
FRACTIONAL DIMENSIONS ± 1/32	
* DIMENSIONS ARE MM (INCHES)	
* ALL DIMENSIONS ARE FINISHED DIMENSIONS	
* DO NOT SCALE DRAWING	

		JBL PROFESSIONAL A Harman International Company Northridge, California 91329 U.S.A.	
TITLE CUSTOMER DRAWING, COUPLING BRACKET			
SIZE A	DRAWING NO. 1000303589	REV A	
SCALE NTS	SHEET 1 OF 1		

4

3

2

1

4

3

2

1

THESE DRAWINGS AND SPECIFICATIONS ARE THE PROPERTY OF JBL INCORPORATED. THEY ARE ISSUED IN STRICT CONFIDENCE AND SHALL NOT BE REPRODUCED OR USED AS THE BASIS FOR MANUFACTURE OR APPARATUS WITHOUT WRITTEN PERMISSION.

REVISIONS			
LTR	DESCRIPTION	DRFT	DATE
A	RELEASE TO MARKETING	MN	4/4/2017

D

D

C

C

B

B

A

A

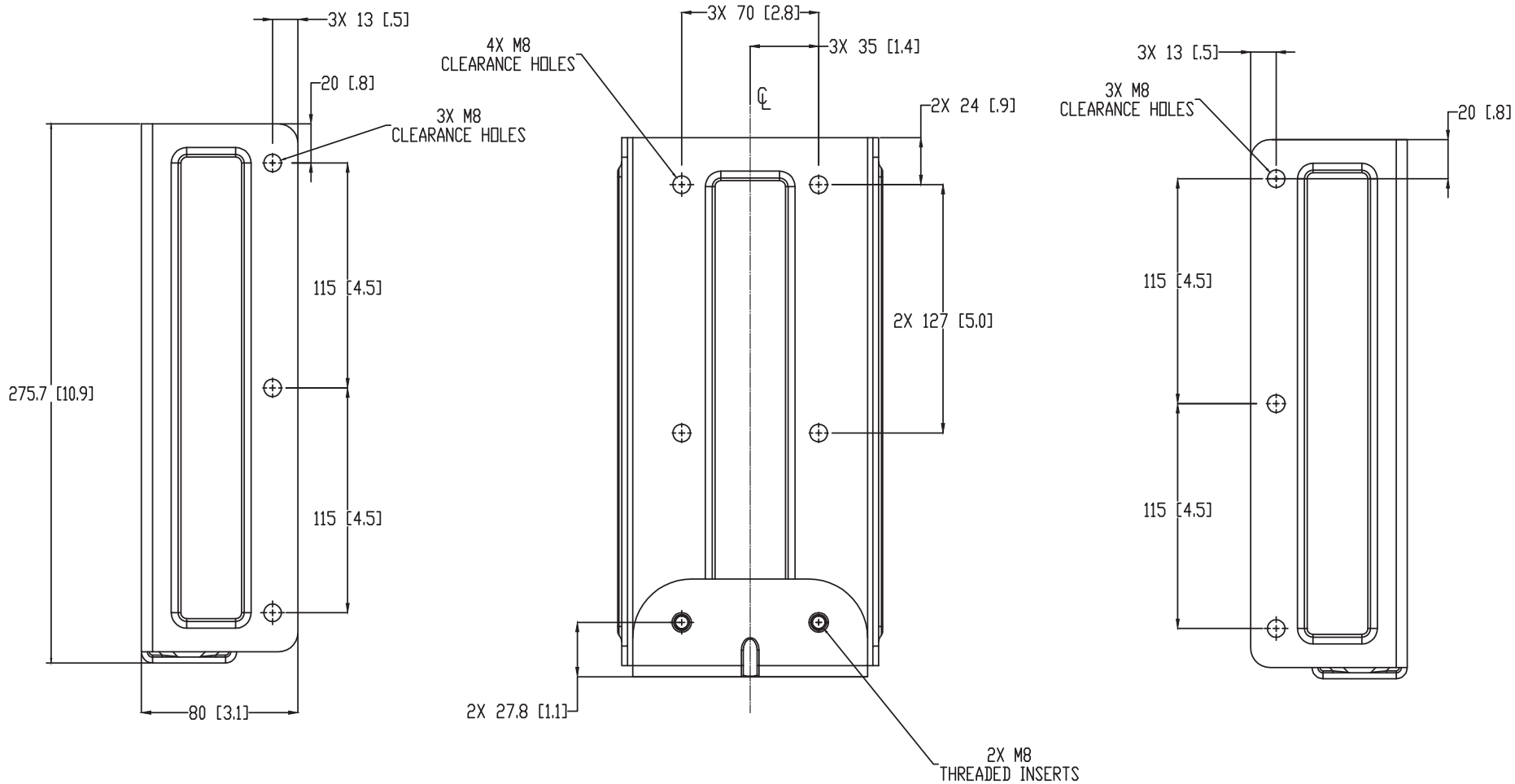

1. COMPONENTS: N/A
2. INPUT CONNECTORS: N/A
3. GRILL: N/A
4. MATERIALS: 3 MM (.12 IN) THICK STEEL.
5. FINISH: POWDER COATED BLACK OR WHITE
6. SUSPENSION POINTS: N/A
7. WEIGHT: 3.6 KG (8 LBS)

⊕ CENTER OF GRAVITY (CG)

NOTES: (UNLESS OTHERWISE SPECIFIED)

TOLERANCES (UNLESS OTHERWISE SPECIFIED)	
.X.XX	± .063 INCH
.XX	± .125 INCH
ANGULAR TOLERANCE OF 0°±30°	
FRACTIONAL DIMENSIONS ± 1/32	
* DIMENSIONS ARE MM (INCHES)	
* ALL DIMENSIONS ARE FINISHED DIMENSIONS	
* DO NOT SCALE DRAWING	

		JBL PROFESSIONAL A Harman International Company Northridge, California 91329 U.S.A.	
TITLE CUSTOMER DRAWING, MTC-CBT-0S3			
SIZE A	DRAWING NO. 1000303616	REV A	
SCALE NTS	SHEET 1	OF 1	

4

3

2

1

4

3

2

1

THESE DRAWINGS AND SPECIFICATIONS ARE THE PROPERTY OF JBL INCORPORATED. THEY ARE ISSUED IN STRICT CONFIDENCE AND SHALL NOT BE REPRODUCED OR USED AS THE BASIS FOR MANUFACTURE OR APPARATUS WITHOUT WRITTEN PERMISSION.

REVISIONS			
LTR	DESCRIPTION	DRFT	DATE
A	RELEASE TO MARKETING	MN	4/4/2017

SPEAKER SIDE BRACKET

WALL SIDE BRACKET

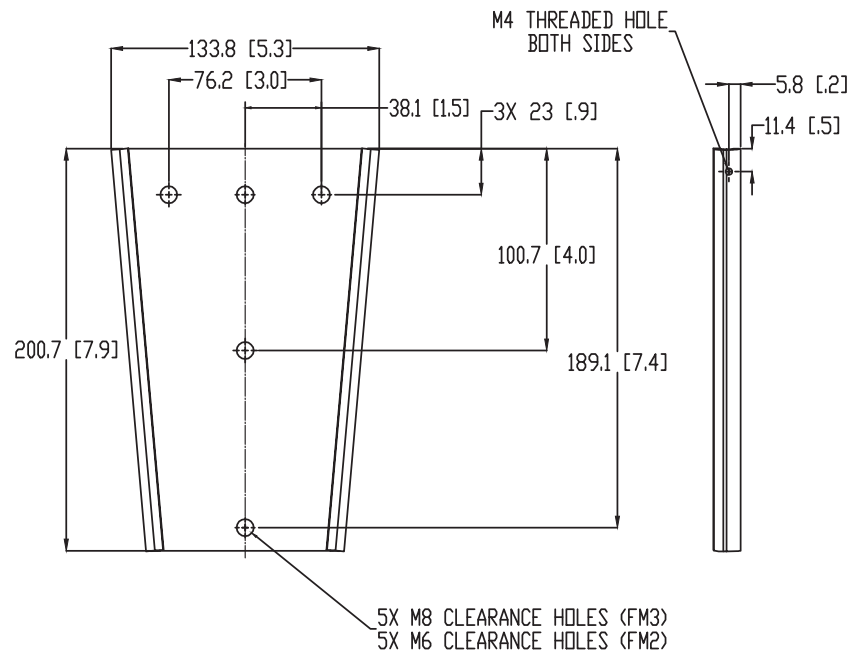
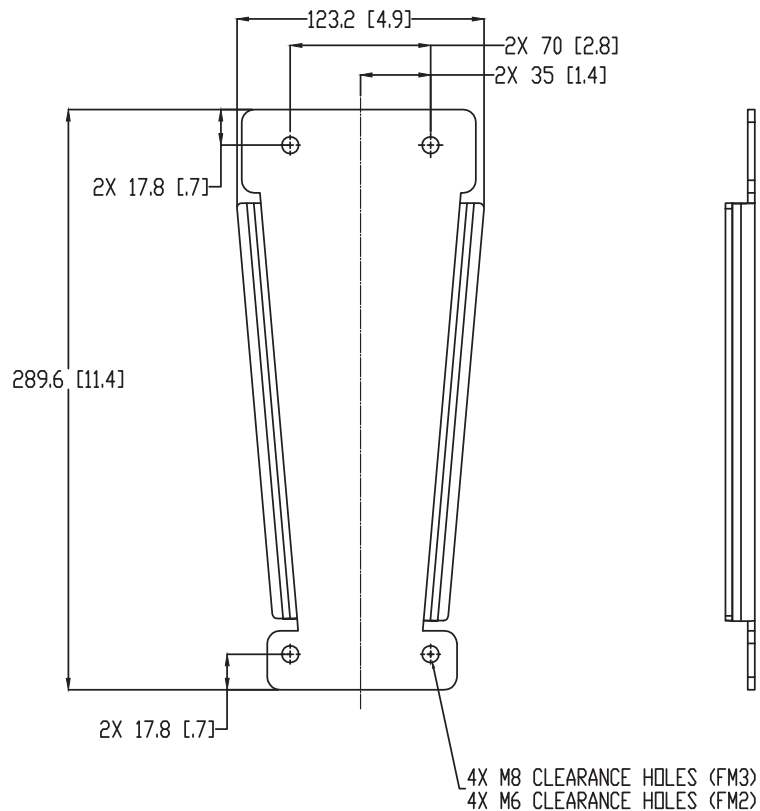
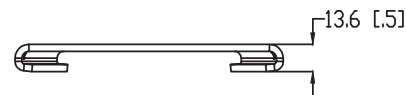

1. COMPONENTS: N/A
2. INPUT CONNECTORS: N/A
3. GRILL: N/A
4. MATERIALS: 3.5 MM (.16 IN) STEEL
5. FINISH: BLACK OR WHITE GLOSS.
6. SUSPENSION POINTS: N/A
7. WEIGHT: 2.3 KG (5 LBS) TOGETHER.

☉ CENTER OF GRAVITY (CG)

NOTES: (UNLESS OTHERWISE SPECIFIED)

TOLERANCES

(UNLESS OTHERWISE SPECIFIED)

.X.XX ± .063 INCH

.X.X ± .125 INCH

ANGULAR TOLERANCE OF 0°±30'

FRACTIONAL DIMENSIONS ± 1/32

* DIMENSIONS ARE MM (INCHES)

* ALL DIMENSIONS ARE FINISHED DIMENSIONS

* DO NOT SCALE DRAWING



JBL PROFESSIONAL
A Harman International Company
Northridge, California 91329 U.S.A.

TITLE
CUSTOMER DRAWING, MTC-CBT-FM2/FM3

SIZE A	DRAWING NO. 1000303622	REV A
-----------	---------------------------	----------

SCALE NTS SHEET 1 OF 1

4

3

2

1

4

3

2

1

THESE DRAWINGS AND SPECIFICATIONS ARE THE PROPERTY OF JBL INCORPORATED. THEY ARE ISSUED IN STRICT CONFIDENCE AND SHALL NOT BE REPRODUCED OR USED AS THE BASIS FOR MANUFACTURE OR APPARATUS WITHOUT WRITTEN PERMISSION.

REVISIONS			
LTR	DESCRIPTION	DRPT	DATE
A	RELEASE TO MARKETING	MN	4/24/2017

D

C

B

A

D

C

B

A

WALL SIDE

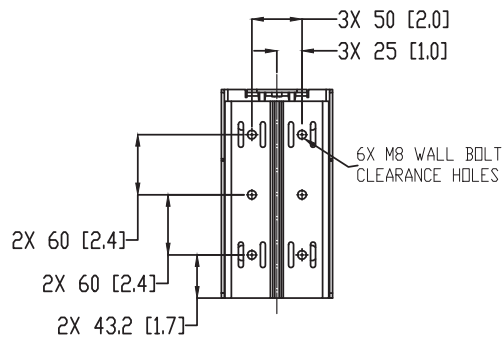

SPEAKER SIDE

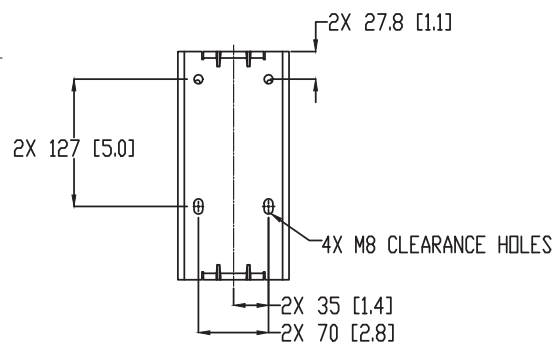
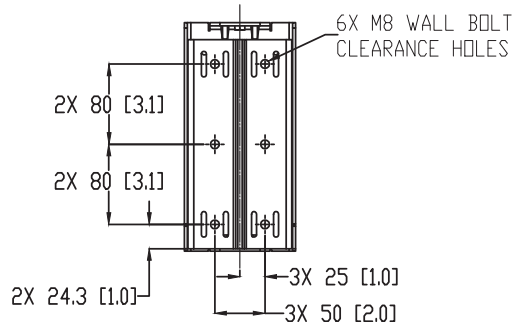
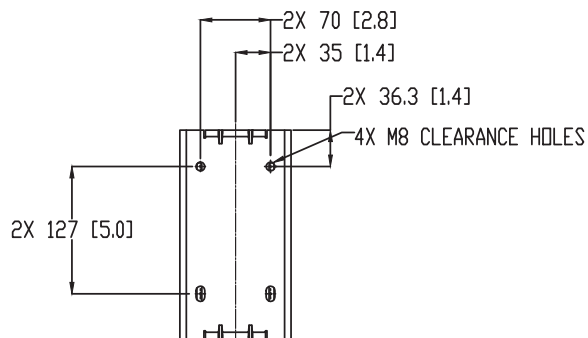

DEFAULT BRACKET INSTALLATION AT 0 DEGREES WITHOUT SWIVEL BRACKET

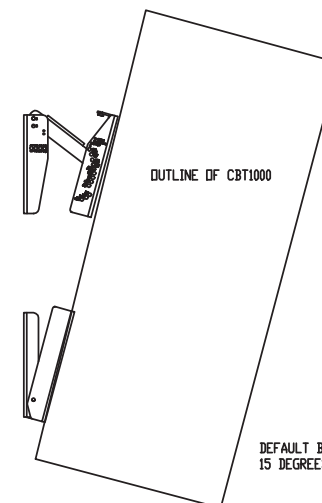
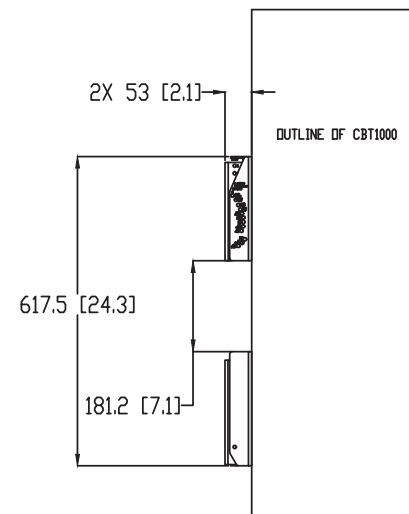

DEFAULT BRACKET INSTALLATION AT 15 DEGREES WITHOUT SWIVEL BRACKET

1. COMPONENTS: N/A
2. INPUT CONNECTORS: N/A
3. GRILL: N/A
4. MATERIALS: STEEL
5. FINISH: POWDER COATED BLACK OR WHITE.
6. SUSPENSION POINTS: N/A
7. WEIGHT: 9 KG (20 LBS) WITHOUT SWIVEL. 10 KG (22 LBS) WITH SWIVEL.

☒ CENTER OF GRAVITY (CG) ⊕

NOTES: (UNLESS OTHERWISE SPECIFIED)

TOLERANCES

(UNLESS OTHERWISE SPECIFIED)

.X.XX ± .063 INCH

.X.X ± .125 INCH

ANGULAR TOLERANCE OF 0°±30'

FRACTIONAL DIMENSIONS ± 1/32

* DIMENSIONS ARE MM (INCHES)

* ALL DIMENSIONS ARE FINISHED DIMENSIONS

* DO NOT SCALE DRAWING



JBL PROFESSIONAL
A Harman International Company
Northridge, California 91329 U.S.A.

TITLE
BRACKET CUSTOMER DRAWING, CBT 1000

SIZE A	DRAWING NO. 1000304163	REV A
------------------	----------------------------------	-----------------

SCALE NTS	SHEET 1	OF 2
---------------------	-------------------	----------------

4

3

2

1

REVISIONS			
LTR	DESCRIPTION	DEPT	DATE
A	RELEASE TO MARKETING	MN	4/24/2017

THESE DRAWINGS AND SPECIFICATIONS ARE THE PROPERTY OF JBL INCORPORATED. THEY ARE ISSUED IN STRICT CONFIDENCE AND SHALL NOT BE REPRODUCED OR USED AS THE BASIS FOR MANUFACTURE OR APPARATUS WITHOUT WRITTEN PERMISSION.

D
C
B
A

D
C
B
A

WALL SIDE

SPEAKER SIDE

DEFAULT BRACKET INSTALLATION AT 0 DEGREES WITH SWIVEL BRACKET

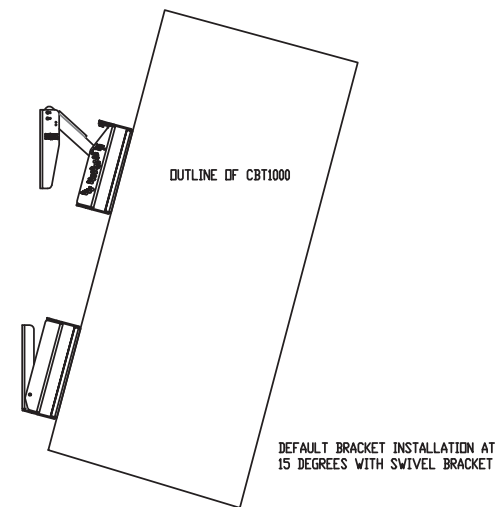
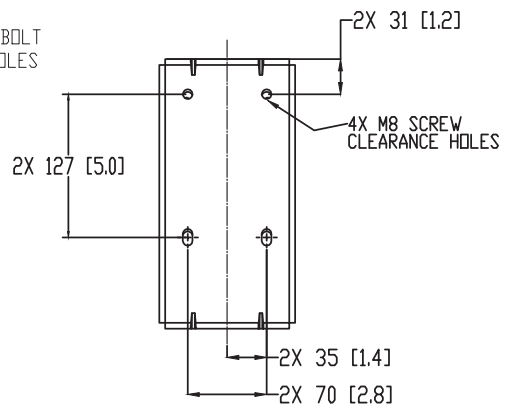
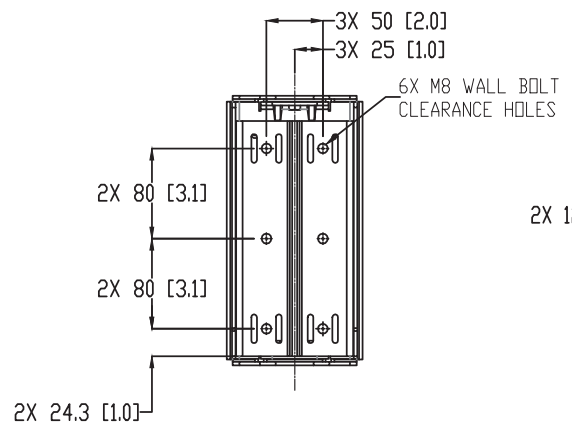
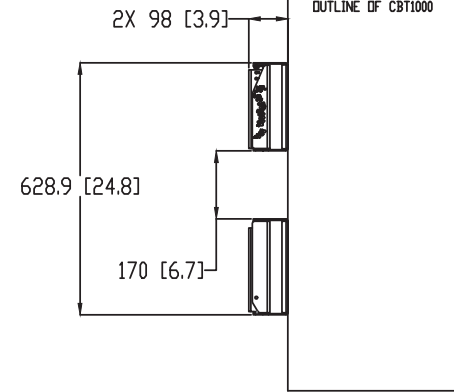
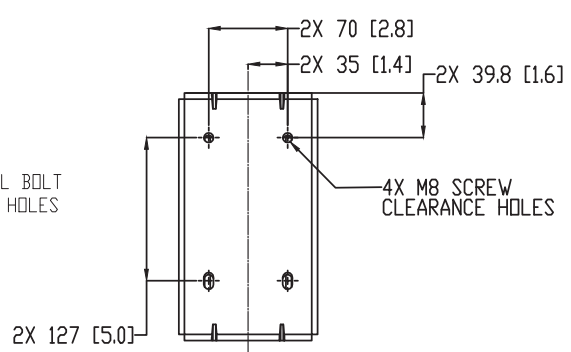
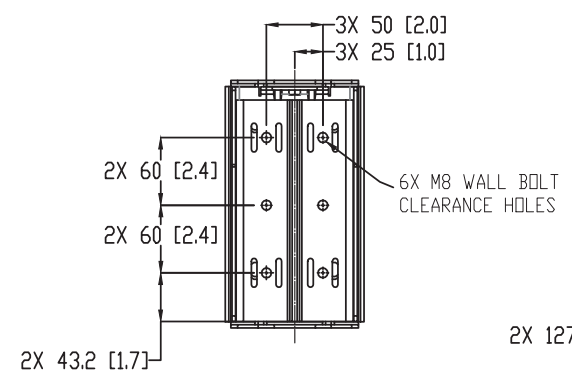

NOTES: (UNLESS OTHERWISE SPECIFIED)

TOLERANCES
(UNLESS OTHERWISE SPECIFIED)

X.XX ± .063 INCH
X.X ± .125 INCH

ANGULAR TOLERANCE OF 0°±30'

FRACTIONAL DIMENSIONS ± 1/32

* DIMENSIONS ARE MM (INCHES)
* ALL DIMENSIONS ARE FINISHED DIMENSIONS
* DO NOT SCALE DRAWING

JBL PROFESSIONAL A Harman International Company Northridge, California 91329 U.S.A.		
TITLE BRACKET CUSTOMER DRAWING, CBT 1000		
SIZE A	DRAWING NO. 1000304163	REV A
SCALE NTS	SHEET 2 OF 2	

4

3

2

1

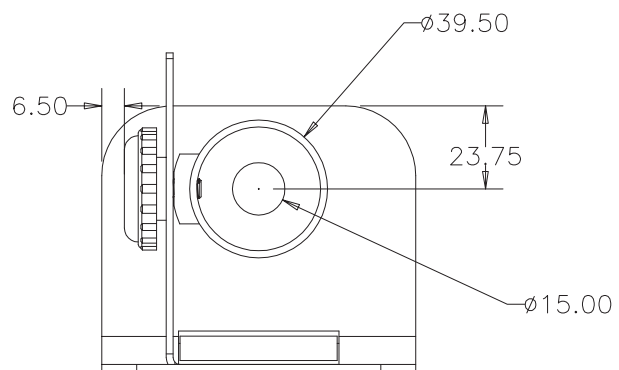
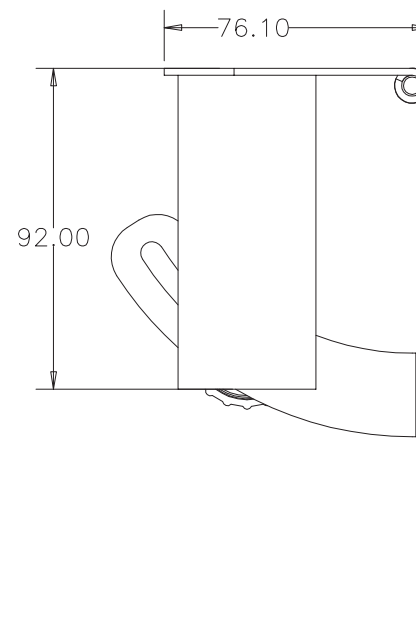
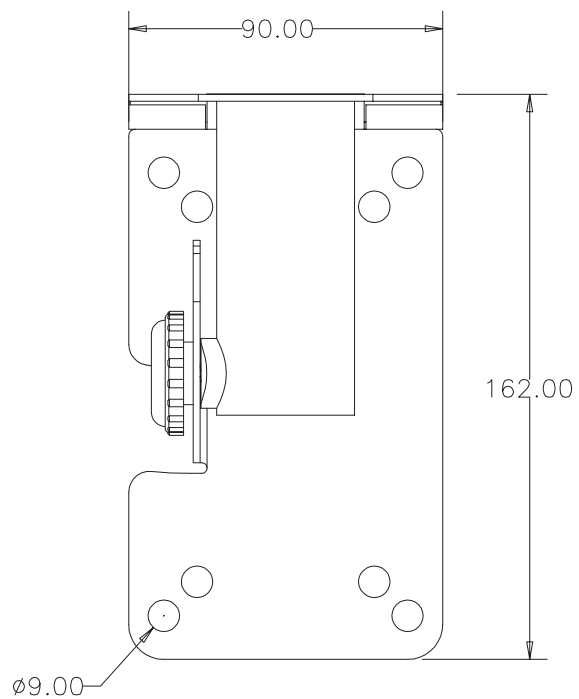
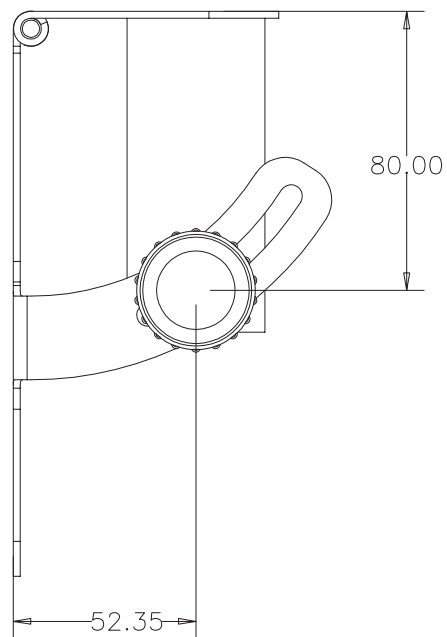

SCALE 0.6

POLE_MOUNT

Bill of Materials - PART NUMBER

Refer to the corresponding Service Bill of Materials (SBOM) to order parts stocked by Harman.
This BOM is for reference only.

Bill of Materials		
Ref ID	Description	QTY
-	S/M, CBT 1000	-
-	END CAP, CBT 1000	1
-	T3XL12 SELF TAPPING FLAT SCREW, CBT 1000	8
-	T3XL12 SELF TAPPING PAN SCREW, CBT 1000	114
-	REAR CABINET, CBT 1000	1
-	WOOFER, CBT 1000	6
-	CONNECTOR PCB EVA 1, CBT 1000	1
-	MAIN PCB, CBT 1000	1
-	TOP CAP, CBT 1000	1
-	M SHAPE TW BAFFLE, CBT 1000	1
-	FULL RANGE WADDING 1, CBT 1000	1
-	LIT,MNL,CBT1000 BRKT INSTALL GDE	1
-	FULL RANGE GRILLE ASM, CBT 1000	1
-	JUMPER COVER, CBT 1000	1
-	T3xL8 SELF TAPPING PAN SCREW, CBT 1000	11
-	TWEETER PCB TOP, CBT 1000	1
-	JUMPER SWITCH, 9 PIN, CBT 1000	4
-	WF BAFFLE EVA 1, CBT 1000	2
-	JUMPER BRACKET, CBT 1000	1
-	JUMPER SWITCH LABEL, CBT 1000	1
-	TWEETER ASSY, CBT 1000	24
-	WF BAFFLE EVA 2, CBT 1000	2
-	FULL RANGE WADDING 2, CBT 1000	1
-	INPUT CAP ASSY, CBT 1000	1
-	JUMPER PCB, CBT 1000	1
-	T4XL25 SELF TAPPING PAN SCREW, CBT 1000	30
-	M8xL35 MACHINE FLAT SCREW, CBT 1000	8
-	PRODUCT LABEL, CBT 1000	1
-	JUMPER COVER SEAL STRIP, CBT 1000	1
-	TWEETER PCB BOTTOM, CBT 1000	1
-	JUMPER BRACKET EVA 1, CBT 1000	2
-	CONNECTOR PCB 13 PIN, CBT 1000	1
-	WF BAFFLE, CBT 1000	1
-	JUMPER BRACKET EVA_2, CBT 1000	2
-	END CAPS EVA, CBT 1000	2
-	CONNECTOR PCB 15 PIN, CBT 1000	1
-	JUMPER PCB EVA, CBT 1000	1
-	M3xL8 MACHINE FLAT SCREW, CBT 1000	6
-	T4XL16 SELF TAPPING PAN WASHER SCREW, CBT 1000	36
-	CBT 1000 JBL LOGO	1

Bill of Materials		
Ref ID	Description	QTY
-	JUMPER COVER EVA, CBT 1000	1
-	SILICONE PLUG, CBT 1000	14
-	JUMPER SWITCH 3 PIN, CBT 1000	1
-	SERIAL LABEL, CBT 1000	1
-	CONNECTOR PCB EVA 2, CBT 1000	1
-	S/M, CBT 1000	-
-	END CAP, CBT 1000	2
-	T3xL12 SELF TAPPING FLAT SCREW, CBT 1000	8
-	WADDING_1, CBT 1000E	1
-	REAR CABINET, CBT 1000	1
-	WOOFER, CBT 1000	6
-	MAIN PCB, CBT 1000	1
-	WOOFER BAFFLE, CBT 1000E	1
-	JUMPER COVER, CBT 1000	1
-	WF BAFFLE EVA 1, CBT 1000	2
-	JUMPER BRACKET, CBT 1000	1
-	JUMPER SWITCH LABEL, CBT 1000	1
-	GRILLE ASM, CBT 1000E	1
-	WF BAFFLE EVA 2, CBT 1000	2
-	FULL RANGE WADDING 2, CBT 1000	1
-	INPUT CAP ASSY, CBT 1000	1
-	T4xL25 SELF TAPPING PAN SCREW, CBT 1000	16
-	M8xL35 MACHINE FLAT SCREW, CBT 1000	8
-	PRODUCT LABEL, CBT 1000	1
-	JUMPER COVER SEAL STRIP, CBT 1000	1
-	JUMPER BRACKET EVA 1, CBT 1000	2
-	JUMPER BRACKET EVA_2, CBT 1000	2
-	END CAPS EVA, CBT 1000	2
-	M3xL8 MACHINE FLAT SCREW, CBT 1000	6
-	T4xL16 SELF TAPPING PAN WASHER SCREW, CBT 1000	30
-	CBT 1000 JBL LOGO	1
-	JUMPER COVER EVA, CBT 1000	1
-	SILICONE PLUG, CBT 1000	14