

VOLUME V

PERPETUAL

**TROUBLE SHOOTER'S
MANUAL**

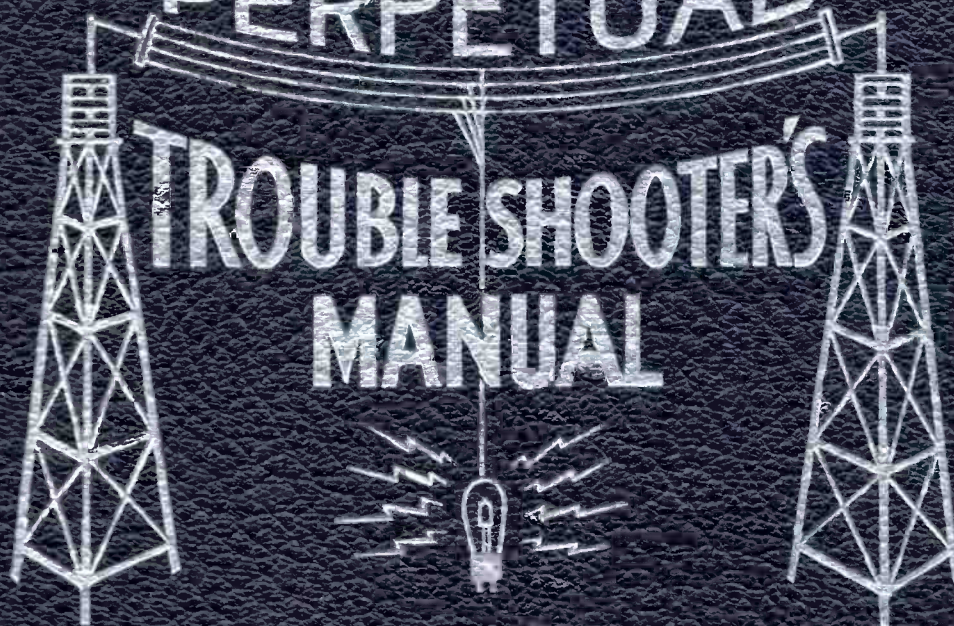

JOHN F. RIDER

GALVIN MFG. CO.

MODEL Twin "8"
Notes, Alignment
MODEL Dual "6"
Notes, Alignment

SERVICE NOTES

1934 Motorola Auto Radio

Twin "8" - Dual "6"

To assist you in gaining an understanding of the operation and servicing of the Dual "6" and Twin "8" we are outlining herein a brief description of the circuits employed together with the function of various units. For general installation instructions see the sheet enclosed with each Motorola set.

TWIN "8" -----The signal is fed into the primary of the antenna coil, which is of the aperiodic type and is induced into its associated secondary circuit, tuned by the 1st gang of the variable condenser. The signal is then fed to the 78 tube used as the first RF amplifier.

Reference to the circuit diagram (Fig. 3) will show that the 2nd RF stage is impedance coupled, feeding its energy into the grid of the 77 autodyne. In the aperiodic type of antenna coil the gain drops slightly near the 500 K.C. end, while in the impedance type coupling used in the 2nd RF coil rises slightly at this point. It will be seen then that by using these two in combination an overall flat sensitivity curve is obtained.

The type 77 autodyne tube is used because of its simplicity, performance and ability to withstand the vibration to which an auto set is subjected. The use of the padder system in the oscillator is used to allow greater accuracy in dial calibration.

In the 85 tube full wave rectification is used and A.V.C. bias is obtained by voltage drop across the 200M ohm resistance connecting the secondary of the diode feeder to ground. Full A.V.C. voltage is applied to the grids of the RF stage and IF stage and to the grid of the 85 tube. The audio component is amplified in the triode section of the 85, which is resistance coupled to the #37, 2nd audio used as a driver and is impedance coupled to the L.A. tubes operating in Push-Pull Class A Prime.

The DUAL "6" -----For all ordinary servicing of the RF section of the Dual "6" the above description will be sufficient.

Reference to the circuit diagram (Fig. 4) will show that a #75 is used as a diode detector resistance coupled to a single 42 output tube.

The manual volume control is in the grid of the 75 whereas in the Twin "8" it is in the grid circuit of the 37 tube.

Fixed bias is used on the 75 grid obtained through the voltage drop across the screen network.

SERVICING

In shooting trouble in an auto radio it is well to endeavor to isolate it to one particular section of the set.

The set may be divided into four parts for servicing. (1) Outer housing. (2) Power supply. (3) Speaker. (4) Set chassis.

The audio end of the chassis may be easily checked by removing the grid cap of the 85 or 75 tube and, if normal, a loud hum will occur.

Check the autodyne circuit by tuning the variable condensers to the minimum position and touching the oscillator stator plates. If a click is heard when touching them and also when removing the finger, it indicates that the autodyne is oscillating properly.

ALIGNMENT OF VARIABLE CONDENSERS

Because of the necessity of aligning the variable condensers with the chassis out of the housing it is important to use a definite point. Unless this is done the dial calibration will be incorrect when replacing the chassis in its housing. This point we may take as 1400 KC which is exactly 32° of angular rotation from minimum condenser setting.

Connect the oscillator feeder to the antenna pin of the chassis and set the oscillator to 1400 KC.

Carefully adjust the trimmers of the oscillator and RF variable condensers for maximum reading of output meter.

Next set the service oscillator to 600 KC rotating the variable condensers to a point 156 degrees 30 min. from minimum condenser setting.

Adjust the 600 KC padder condenser (accessible from the front of the chassis) for highest output reading.

The 600 KC setting may also be found by setting the service oscillator to 600 KC. Tune in the oscillator signal and rotate the variable condensers back and forth while adjusting the 600 KC trimmer condenser for highest reading of the output meter. The variable condensers should now track perfectly and coincide with the dial calibration.

ALIGNMENT OF THE IF TRANSFORMERS

The IF transformers and diode feeder in the Twin "8" and Dual "6" should always be aligned with a good calibrated service oscillator or signal generator.

Connect the feeder from the oscillator to the grid of the 77 autodyne tube. Remove the grid connection and connect a 500M ohm resistor from grid of the tube to the ground.

Rotate the variable condensers to the full open position.

Set the oscillator to a frequency of 252 KC and adjust the IF and diode feeder trimmers to obtain maximum reading on the output meter.

PART REPLACEMENTS

In the design of the Twin "8" and Dual "6" interchangeability of parts has been accomplished wherever possible. This greatly simplifies service. In these sets the complete power packs and their various parts along with the RF oscillator, IF coils and variable condenser are interchangeable.

Volume Control -- (1) Remove rear set cover. (2) Disconnect volume control and switch leads. (3) Remove hex head screws holding volume control mounting plate and remove complete assembly. (4) Replace with standard Motorola replacement control.

By-Pass Condensers -- (1) Disconnect condenser and push up-wards from bottom of chassis. (2) Insert new condenser from bottom of chassis and reconnect.

Tube Sockets -- (1) Disconnect all wires at socket contacts, insert tube in socket, press down firmly and turn in counter-clockwise direction until released. (2) Place new socket on tube base, press it down firmly into chassis hole and turn in clockwise direction.

Coil and IF Transformer -- (1) Each coil may be removed without disturbing any other units. (2) Remove mounting screws, disconnect its respective wires and insert new coil.

MODEL Twin "8"
 MODEL Dual "6"
 Control Adjustment

GALVIN MFG. CO.

Fig. 6

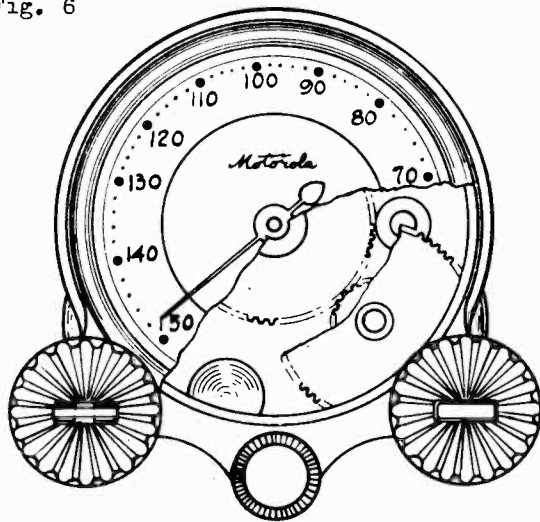

ADJUSTMENT OF MOTOROLA UNIVERSAL AIR-
 PLANE TYPE CONTROL

The general construction of the control head is shown in the cut away view. (Fig. 6).

In connecting the flexible shafts to the control head:

1. Insert the volume control shaft into the control head to its limit then release the shaft housing about 1/32 inch to relieve any binding. Tighten set screw (D) Fig. (7) against housing.
2. Insert condenser drive shaft into control head so that the shaft extends into the tuning knob. Tighten knob set screws A and B. Release shaft housing about 1/32 inch to relieve binding.

Tighten set screw (C) against housing. The tuning knobs may be removed by completely removing the set screws E and F, Fig. (7). This is necessary when mounting control in instrument panel.

To adjust indicator arrow, tune in a station of known frequency preferably between 1000 KC and 1300 KC, then insert screw driver in rear center of control head and adjust indicator to correct frequency setting.

Special lengths of flexible shafts may be secured from your Motorola distributor or from the factory.

Fig. 7

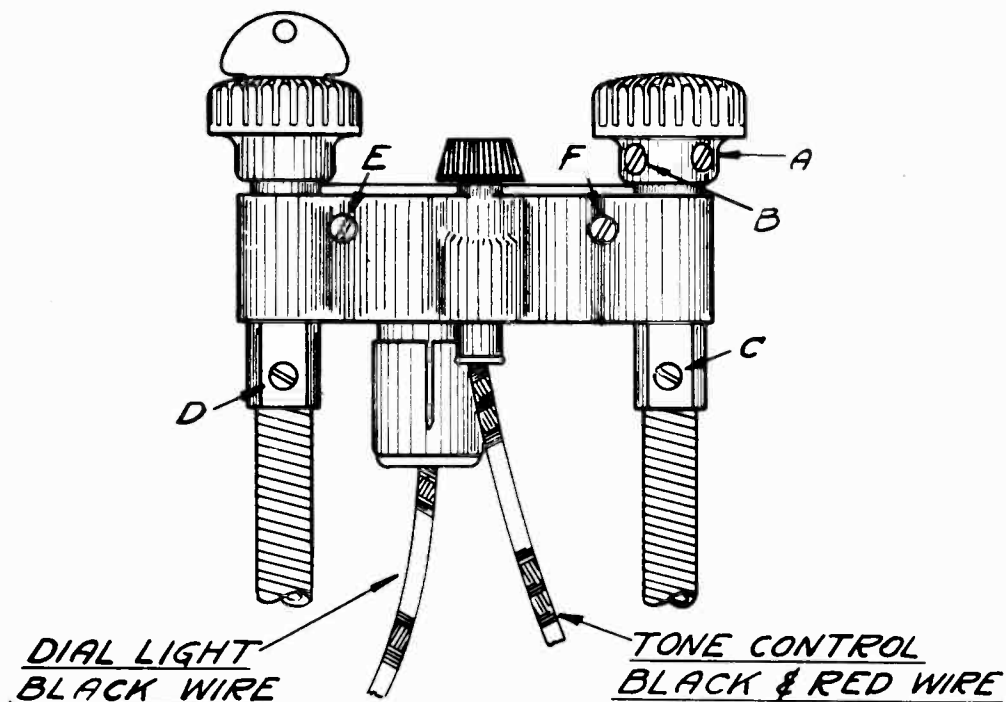

GALVIN MFG. CO.

MODEL Twin "8"
Resistance Test
Data

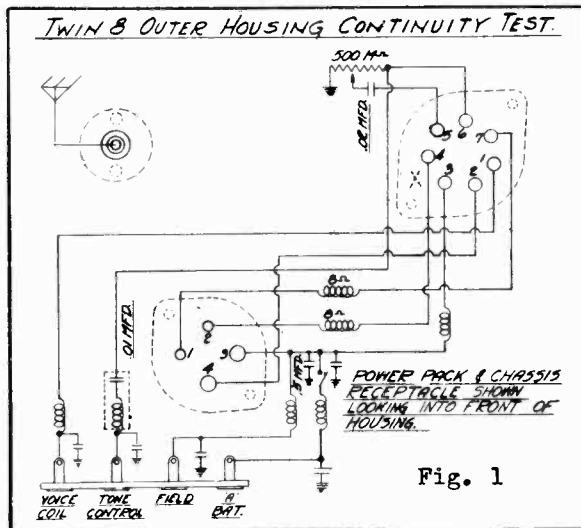

Fig. 1

TWIN "8"					
VOLTAGE AT BATTERY 6.2					
TUBE	PLATE	SCREEN	CATHODE	CONTROL GRID	FIL.
78 R.F.	220	55	.5	*	5.8
77 AUTODYNE	220	55	4.5	-	5.8
78 I.F.	220	55	1.5	*	5.8
85 DIODE	40			-	5.8
37 1st AUDIO	60			3.8**	5.8
LA POWER	222	220		-20**	5.8

* A.V.C. VOLTAGE APPLIED TO GRIDS.
** VOLTAGE MEASURED FROM GRID. RETURN TO GROUND.

CONTINUITY OF TWIN "8" CHASSIS

Refer to circuit diagram Fig. (3)

TEST	SHOULD TEST	IF OTHERWISE
Terminal #4 to P of LA.	400 ohm	Open output trans.
P of 37 tube to grid of LA	Open	Shorted .05 cond.
Terminal #7 to P of 1st 78.	25 ohm	Open prim. choke.
Terminal #7 to P of 77.	35 ohm	Open prim. I.F.
Terminal #7 to P of 2nd 78.	110M ohm	Open resistor.
Terminal #7 to Screen of LA	Short	Loose connect.
Diode of 85 to Ground	200M ohm	AVC network shorted.
Terminal #2 to ground	500 ohm	Open 400 or 100 ohm resistor.
Terminal #2 to Grids of LA's	2000 ohm	Defective input Choke.
Terminal #7 to Ground.	200M ohm	Open bleeder or shorted plate bypass.
Screen of 78 to ground	100M ohm	Shorted .02 screen bypass condenser.

CONTINUITY OF TWIN "8" HOUSING AND SPEAKER

Readings taken from front of housing with chassis removed. Volume control full on position. "A" Battery disconnected. Speaker connected.

TEST	SHOULD TEST	IF OTHERWISE
Chassis receptacle terminal #1 to Voice Coil terminal	Closed	Loose connections.
Chassis receptacle terminal #2 to Power Pack #4	Closed	Loose connections.
Chassis receptacle terminal #3 to Power Pack #3	Closed	Open fil. choke.
Chassis receptacle terminal #4 to Power Pack #2	8 ohm	Open R.F. choke.
Chassis receptacle terminal #6 to Ground500M ohm	Open volume control.
Chassis receptacle terminal #6 to chassis recept. #5	Open	Shorted .02 coupling cond.
Chassis receptacle terminal #7 to Power Pack Term. #1.	8 ohm	Open R.F. choke.
Chassis receptacle terminal #1 to ground	2 ohm	Open voice coil.
Power Pack terminal #3 to A Bat. terminal	Closed	Defective power switch.
Power Pack terminal #3 to ground4½ ohm	Open speaker field.
Ant. receptacle	To ground	Shorted ant.

MODEL Dual "6"
Resistance Test
Data

GALVIN MFG. CO.

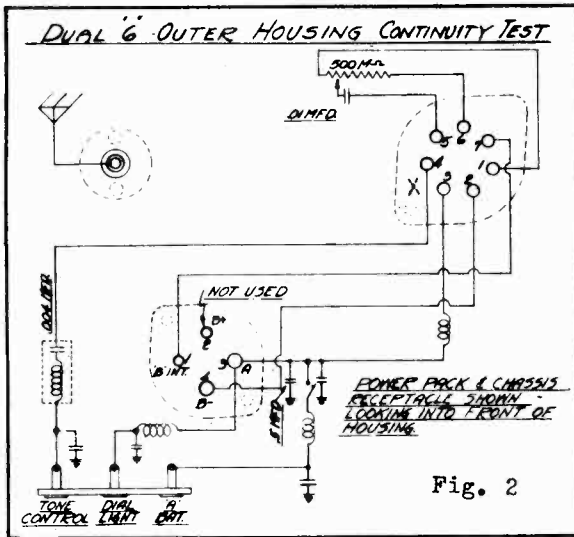

Fig. 2

DUAL "6"					
TUBE	PLATE	SCREEN	CATHODE	CONTROL GRID	FIL.
78 R.F.	210	70	.6	*	5.8
77 AUTODYNE	210	70	5.6	-	5.8
78 I.F.	210	70	2.5	*	5.8
75 DIODE	65		.6	-	5.8
42 POWER	200	205		-16	5.8

* A.V.C. VOLTAGE APPLIED TO GRIDS.

CONTINUITY OF CHASSIS DUAL "6"

Refer to circuit diagram Fig. (4)

	SHOULD READ	IF OTHERWISE
Terminal #5 to Grid 75	Short	Loose connect.
Terminal #2 to ground.		
Terminal #7 to ground.	300 ohm	Open bias resistor.
Terminal #6 to ground.	60M ohm	Shorted plate or screen by-pass open resistor.
Terminal #3 to ground.		
Terminal #4 to P of 75 tube.	250 ohm	Def. 75 bias resistor.
Terminal #6 to ground	Low resistance	Through tube fil.
Terminal #3 to ground.	Short	Loose connect.
Terminal #4 to P of 75 tube.		
Terminal #6 to ground	200M ohm	AVC network short to ground.

CONTINUITY OF DUAL "6" SET HOUSING

Readings taken from front of housing with chassis removed. Volume control full on position "A" battery disconnected.

TEST	SHOULD TEST	IF OTHERWISE
Chassis recept. term. #1 to Term. #6	500M ohm	Def. volume control.
Chassis recept. term. #2 to Power Pack term. #4		
Chassis recept. term. #3 to Power Pack term. #3	Closed	Loose connect.
Chassis recept. term. #3 to "A" Bat. Term. board		
Chassis recept. term. #4 to tone control term. board	Open	Shorted .004 term. cond.
Chassis recept. term. #5 to term. #6		
Ant. receptacle to ground	Open	Shorted antenna.
Chassis recept. term. #5 to term. #6		

MODEL Dual "6"
Schematic

GALVIN MFG. CO.

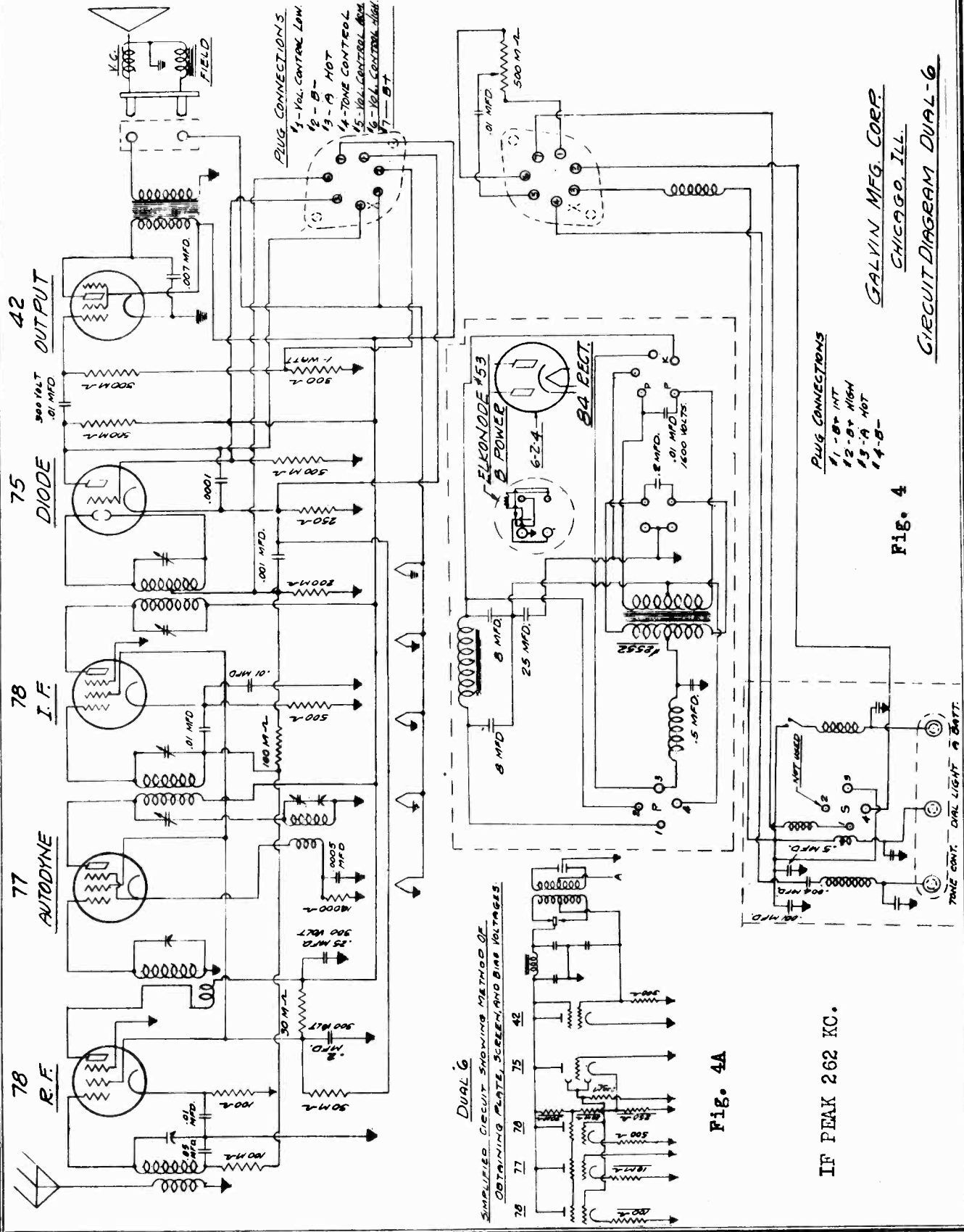

DUAL '6'
SIMPLIFIED CIRCUIT SHOWING METHOD OF
OBTAINING PLATE, SCREEN AND BIAS VOLTAGES.

Fig. 4A

IF PEAK 262 KC.

PLUG CONNECTIONS

- 11 - 84 INT
- 12 - 84 HIGH
- 13 - A HOT
- 14 - B -

Fig. 4

GALVIN MFG. CORP.
CHICAGO, ILL.

CIRCUIT DIAGRAM DUAL-6

TONE CONT. ORAL LIGHT 9 BATT.

GALVIN MFG. CO.

MODEL Twin "8"
 MODEL Dual "6"
 Power Pack Test Data

POWER PACK CONTINUITY TEST

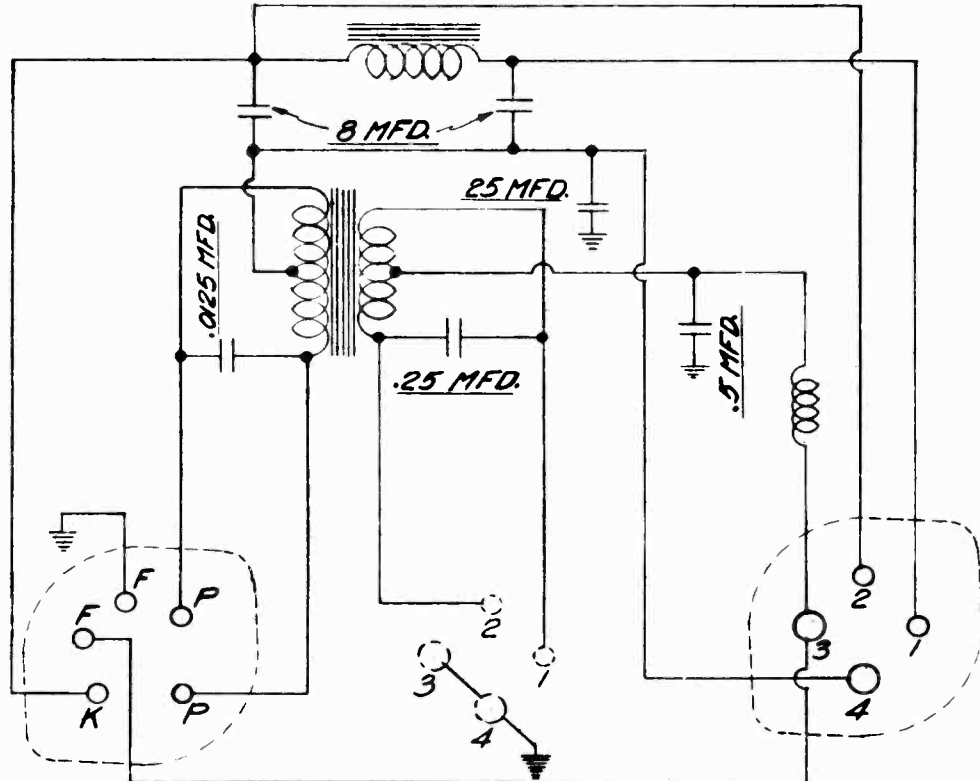

Fig. 5

CONTINUITY TEST ON POWER PACK

<u>TEST</u>	<u>SHOULD TEST</u>	<u>IF OTHERWISE</u>
1. Terminal #1 to K of 84 socket . .	300 ohm	Defective filter choke.
2. Terminal #1 to terminal #4 socket	Open *	Effective 8 mfd. cond.
3. Terminal #4 to ground socket. . .	Open *	Defective 25 mfd. cond.
4. Terminal #2 to terminal #4 socket	Open *	Defective 8 mfd. cond.
5. Terminal #3 to terminal #1 and 2 Elk. socket:	Closed	Loose connection.
6. Terminal #3 to ground	Closed through 84 fil.	Def. tube shorted
7. Terminal #4 to P and P of 84 socket	200 ohm	.5 mfd. cond. Def. sec. power trans.
8. P to P on 84 socket	400 ohm	Shorted buffer cond.
9. K to P and P of 84 socket	Open	Defective 84 tube.

* On tests #2, 3 and 4 allowance should be made for polarization, or normal leakage of electrolytic condenser.

MODEL 34
Schematic

GALVIN MFG. CO.

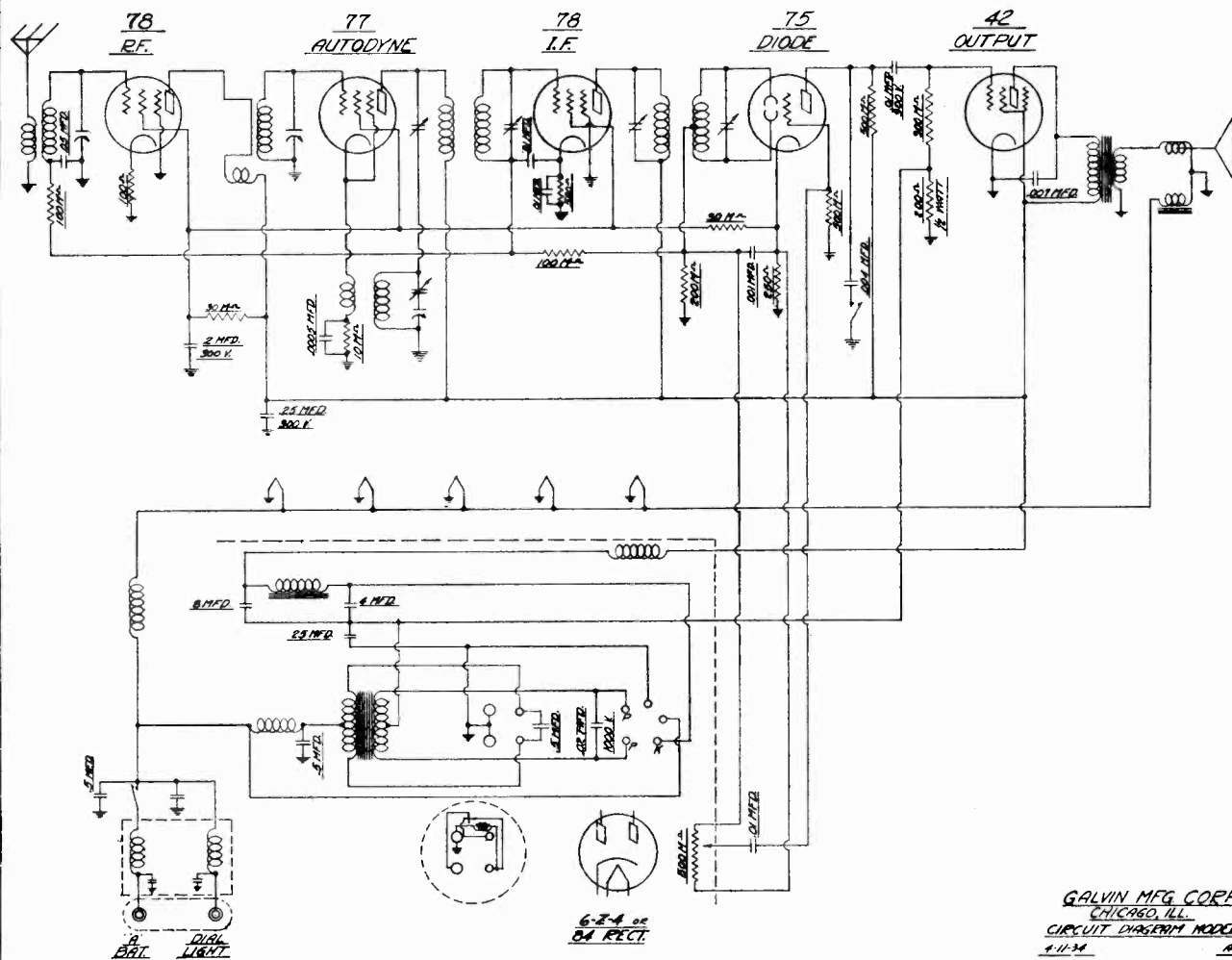

GALVIN MFG. CORP.
CHICAGO, ILL.
CIRCUIT DIAGRAM MODEL #34
4-11-34 AM/17

ADJUSTMENT OF TUNING CONDENSER GEAR

The tuning condenser gear may be adjusted against its drive pinion by simply turning the cam screw, reaching through a hole in the left side of front cover. This hole is covered by button, easily pried upward with screwdriver. Turn screw to the left until slight drag is felt on the station selector knob, then back off slightly until free movement is obtained. After adjustment has been made tighten small locking screw located on face of cam screw.

BALANCING THE SET TO THE ANTENNA

After the set is installed ready for operation, it may be necessary to balance the set to the antenna. This is done by adjustment of the antenna trimmer, located under a 3/8" hole in the TOP of the set. This hole is covered by a button which is removed by simply prying upward with a screw driver.

In making this adjustment tune in a very weak station around 120 to 140 on the dial. Adjust the trimmer with a screw driver until the point of maximum volume is reached.

ADJUSTING THE STATION SELECTOR INDICATOR

Tune in a station of known frequency preferably between 1000KC and 1300 KC.

Insert a screw driver in the center rear of the control head and adjust indicator to the frequency of the station being received. (See Fig. 4).

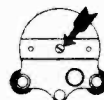

Fig. 4

GENERAL HOUSEHOLD UTILITIES CO.

MODEL 450 (4A)

Temporary
Alignment
Parts List

Part No.	Specifications	Quantity Required	Part No.	Specifications	Quantity Required
20861	Attachment Cord	1	29132	Antenna Coil Assembly	1
20862	Grid Cap	2	29135	0.1 MFD 100 Volt Tubular Condenser	1
21598	Rubber Grommet	1	29136	1st I.F. Assembly	1
22858	1 Meg. Ohm Resistor, $\frac{1}{2}$ Watt	1	29137	2nd I.F. Assembly	1
23284	Bakelite Washer	6	29159	Double Pointer Knob	1
23358	Vertical Terminal Strip	1	29160	Single Pointer Knob	1
23538	200,000 Ohm Resistor, $\frac{1}{2}$ Watt	1	29164	50 M. Ohm Resistor	1
23849	500,000 Ohm Resistor, $\frac{1}{2}$ Watt	1	29168	Dual 8 MFD 450 Volt Electrolytic Cond. denser	1
23998	250,000 Ohm Resistor, $\frac{1}{2}$ Watt	1	29170	.017 MFD 500 Tubular Condenser	1
24254	1,000 Mmf. Condenser	1	29178	Speaker Cable Assembly	1
24789	4 MFD - 25 V. Dry electrolytic Condenser	1	29264	Antenna and Gr. Lead Assembly	1
26564	Tube Shield Base	2	31077	Socket (5 Prong)	1
26534	35000 Ohm Resistor, $\frac{1}{2}$ Watt	1	31079	Socket (6 Prong)	1
27358	I.F. Shield and Eyebolt Assembly	1	31080	Socket (7 Prong)	1
27382	Trimmer Condenser Assembly	1	62523	5/8" X. #8 Hex. Hd. S.F. Screw Type Z	4
27784	400 Ohm Resistor, $\frac{1}{2}$ Watt	1	62847	Flat Washer 500 ODX .187 ID	4
27831	Pilot Light Assembly	2			
28045	Pilot Lamp	2			
28366	Oscillator Coil Mtg. Strip	1			
28522	Trimmer Condenser Assembly	1			
28721	.01 MFD 500 Volt Tubular Condenser	1	28944	Field Yoke and Pole Piece Assembly	1
28722	.04 MFD 500 Volt Tubular Condenser	1	29038	Cone Mtg. Gasket	1
28726	.1 MFD 400 Volt Tubular Condenser	1	29040	Speaker complete	1
28729	.5 MFD 100 Volt Tubular Condenser	1	29042	Field Coil	1
28876	.02 MFD 500 Volt Tubular Condenser	1	29043	Speaker Head Assembly	1
29087	Tube Shield	2	29047	Terminal Strip Cover	1
29115	Canthorn Resistor	1	29741	Transformer	1
29117	Two Gang Condenser	1	29769	Clamp Ring	1
29118	2 Meg. Ohm Resistor, $\frac{1}{2}$ Watt	2	31555	Cone and Voice Coil Assembly	1
29119	Volume Control	1			
29120	Range Switch	1			
29121	Power Transformer Assembly - 60 Cycle	1			

Complete Speakers may not be returned for credit.

ALIGNMENT PROCEDURE CHASSIS 4A

1. Equipment value consistent with obtaining a readable indication on out-put meter.

A - Test Oscillator

A - A modulated oscillator capable of producing signals at 262 K.C., 455 K.C., 1400 K.C., 3700 K.C. (10 M.C. and 20 M.C. used on 7B & 11A only) is necessary for alignment of the 1934 Grunow Receivers.

B - Out-put Meter

This may be any of the standard out-put meters on the marked but should be sufficiently sensitive to provide a good deflection at low signal strength, it should also incorporate an adjustable shunt so that extremely strong signals may be read.

C - Coupling Means

Coupling condensers of .25 Mfd. and 200 Mmf. should be used when coupling oscillator to receiver during alignment as specified in following paragraphs.

2. Dial Setting

Turn dial pointer so that end mark of dial is directly under pointer with variable condenser fully meshed.

It will be necessary to simulate the dial plate during alignment when Chassis is removed from cabinet.

3. I.F. Alignment

A - Connect signal lead of oscillator through .25 Mfd. condenser to grid of 6F7 (1st Detector Tube) located on rear right hand corner of Chassis as you face same. Connect the ground lead to the Chassis.

B - Place oscillator in operation at 455 K.C. and turn receiver volume control to maximum. (Volume Control should remain at maximum during entire alignment procedure and signal should be attenuated at oscillator to lowest

6. 3700 K.C. Alignment

A - Throw Range Switch to S.W. position.

B - Set oscillator in operation at 3700 K.C.

C - Turn Dial pointer to 3700 K.C. or 3.7 M.C.

D - Adjust 3700 K.C. Trimmer (A8) located on top of Chassis near variable condenser.

7. Recheck Dial Calibration and 1400 K.C. Alignment.

Model 450

Chassis 4A - Speaker 6B1

Part No.	Specifications	Quantity Required	Part No.	Specifications	Quantity Required
20861	Attachment Cord	1	29132	Antenna Coil Assembly	1
20862	Grid Cap	2	29135	0.1 MFD 100 Volt Tubular Condenser	1
21598	Rubber Grommet	1	29136	1st I.F. Assembly	1
22858	1 Meg. Ohm Resistor, $\frac{1}{2}$ Watt	1	29137	2nd I.F. Assembly	1
23284	Bakelite Washer	6	29159	Double Pointer Knob	1
23358	Vertical Terminal Strip	1	29160	Single Pointer Knob	1
23538	200,000 Ohm Resistor, $\frac{1}{2}$ Watt	1	29164	50 M. Ohm Resistor	1
23849	500,000 Ohm Resistor, $\frac{1}{2}$ Watt	1	29168	Dual 8 MFD 450 Volt Electrolytic Cond. denser	1
23998	250,000 Ohm Resistor, $\frac{1}{2}$ Watt	1	29170	.017 MFD 500 Tubular Condenser	1
24254	1,000 Mmf. Condenser	1	29178	Speaker Cable Assembly	1
24789	4 MFD - 25 V. Dry electrolytic Condenser	1	29264	Antenna and Gr. Lead Assembly	1
26564	Tube Shield Base	2	31077	Socket (5 Prong)	1
26534	35000 Ohm Resistor, $\frac{1}{2}$ Watt	1	31079	Socket (6 Prong)	1
27358	I.F. Shield and Eyebolt Assembly	1	31080	Socket (7 Prong)	1
27382	Trimmer Condenser Assembly	1	62523	5/8" X. #8 Hex. Hd. S.F. Screw Type Z	4
27784	400 Ohm Resistor, $\frac{1}{2}$ Watt	1	62847	Flat Washer 500 ODX .187 ID	4
27831	Pilot Light Assembly	2			
28045	Pilot Lamp	2			
28366	Oscillator Coil Mtg. Strip	1			
28522	Trimmer Condenser Assembly	1			
28721	.01 MFD 500 Volt Tubular Condenser	1	28944	Field Yoke and Pole Piece Assembly	1
28722	.04 MFD 500 Volt Tubular Condenser	1	29038	Cone Mtg. Gasket	1
28726	.1 MFD 400 Volt Tubular Condenser	1	29040	Speaker complete	1
28729	.5 MFD 100 Volt Tubular Condenser	1	29042	Field Coil	1
28876	.02 MFD 500 Volt Tubular Condenser	1	29043	Speaker Head Assembly	1
29087	Tube Shield	2	29047	Terminal Strip Cover	1
29115	Canthorn Resistor	1	29741	Transformer	1
29117	Two Gang Condenser	1	29769	Clamp Ring	1
29118	2 Meg. Ohm Resistor, $\frac{1}{2}$ Watt	2	31555	Cone and Voice Coil Assembly	1
29119	Volume Control	1			
29120	Range Switch	1			
29121	Power Transformer Assembly - 60 Cycle	1			

Complete Speakers may not be returned for credit.

MODEL 450 (4A)

Temporary
Schematic, Trimmers

GENERAL HOUSEHOLD UTILITIES CO.

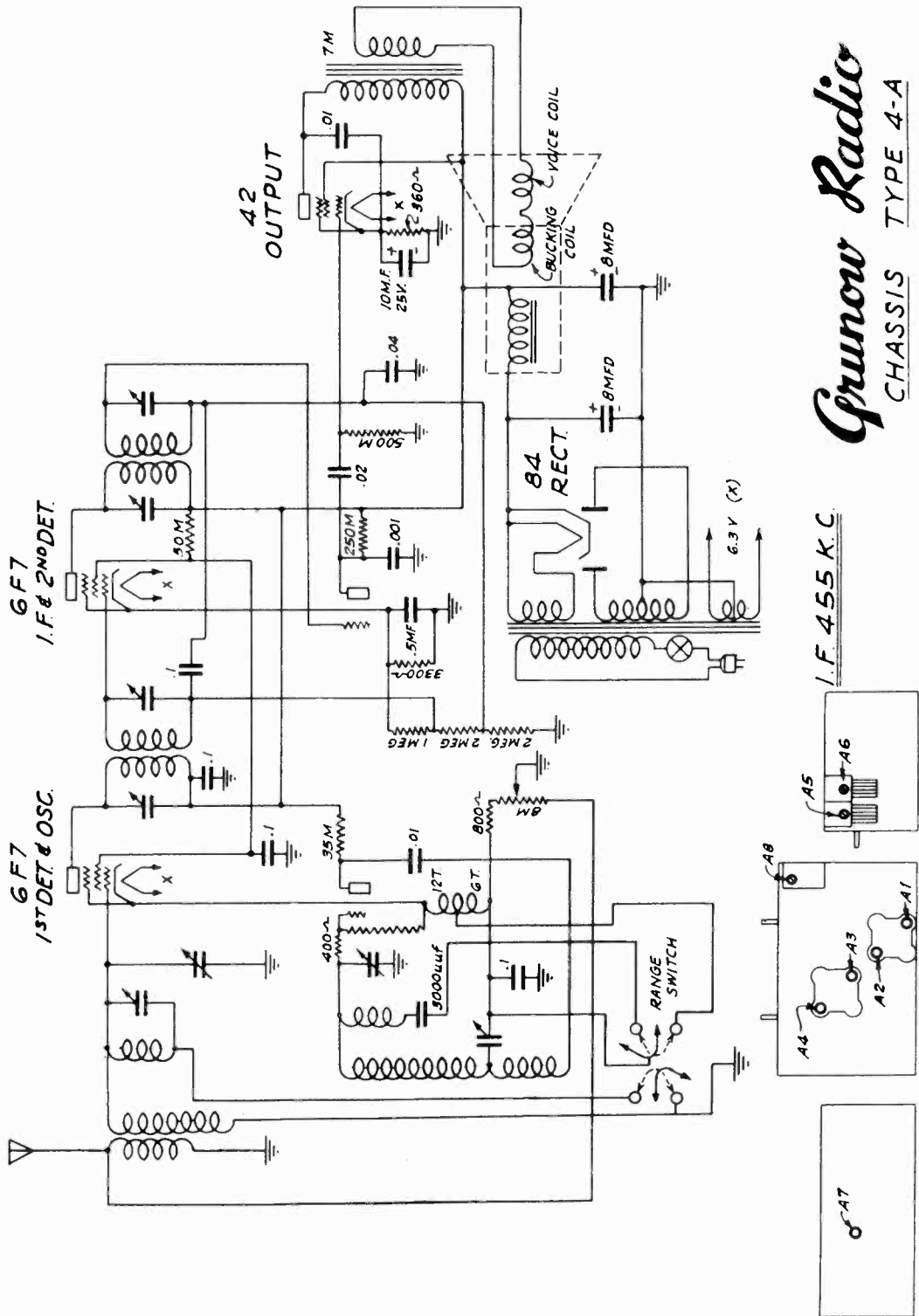

Grunow Radio

CHASSIS TYPE 4-A

RECEIVER MODEL 450
SPEAKER 881
GENERAL HOUSEHOLD UTILITIES CO.
RADIO SERVICE DEPARTMENT
CHICAGO ILL
RAS 19

REAR VIEW BOTTOM VIEW RIGHT END
LOCATION OF TRIMMER CONDENSERS.

GENERAL HOUSEHOLD UTILITIES CO.

MODEL 460 (4B)
Temporary
Alignment

SEPTEMBER 1934

Grunow Radio

TEMPORARY SERVICE NOTES & PARTS LIST

CHASSIS TYPE 4B
RECEIVER MODEL 460
SPEAKER TYPE 8B3GENERAL HOUSEHOLD UTILITIES CO.
CHICAGO U.S.A.

31555-1

LITHO. U.S.A.

ALIGNMENT PROCEDURE CHASSIS 4B

1. Equipment

A - Test Oscillator

A - A modulated oscillator capable of producing signals at 455 K.C., 600 K.C., 1400 K.C. and 1700 K.C. is necessary for alignment of the 4B Grunow Receivers.

B - Out-put Meter

This may be any of the standard out-put meters on the market but should be sufficiently sensitive to provide a good deflection at low signal strength, it should also incorporate an adjustable shunt so that extremely strong signals may be read.

C - Coupling Means

Coupling condensers of .25 Mfd. and 200 Mmf. should be used when coupling oscillator to receiver during alignment as specified in following paragraphs.

2. Dial Setting

Turn dial pointer until condensers are fully meshed. The dial pointer should be on the horizontal line of the dial.

3. I. F. Alignment

A - Connect signal lead of oscillator through .25 Mfd. condenser to grid of 6A7 (1st Detector Tube) located on front right hand corner of Chassis. Connect the ground lead to the Chassis.

B - Place oscillator in operation at 455 K.C. and turn receiver volume control to maximum. (Volume Control should remain at maximum during entire alignment procedure and signal should be attenuated at oscillator to lowest value consistent with obtaining a readable indication on out-put meter).

C - Align three I.F. trimmers (A1-A2-A3) located on top of Chassis. Two on top of 1st I.F. Can and 1 on Chassis between 42 and 6F7 tube.

4. 1700 K.C. Alignment

A - Connect signal lead of oscillator to antenna lead, (the blue wire leading from rear of chassis) through 200 Mmf. Condenser.

B - Set dial pointer at 1700 K.C. and place oscillator in operation at 1700 K.C.

C - Align oscillator trimmer (A4) which is the first of the two on the variable condenser.

5. 1400 K.C. Alignment

A - Place oscillator in operation at 1400 K.C.

B - Set dial pointer at 1400 K.C.

C - Align antenna trimmer (A5). This operation may require rocking the variable condenser back and forth through resonance. The object of this operation is to be sure that the receiver will reach 1712 K.C. and at the same time have maximum sensitivity on the rest of the broadcast band.

MODEL 460 (4B)

Temporary
Schematic
Trimmers

GENERAL HOUSEHOLD UTILITIES CO.

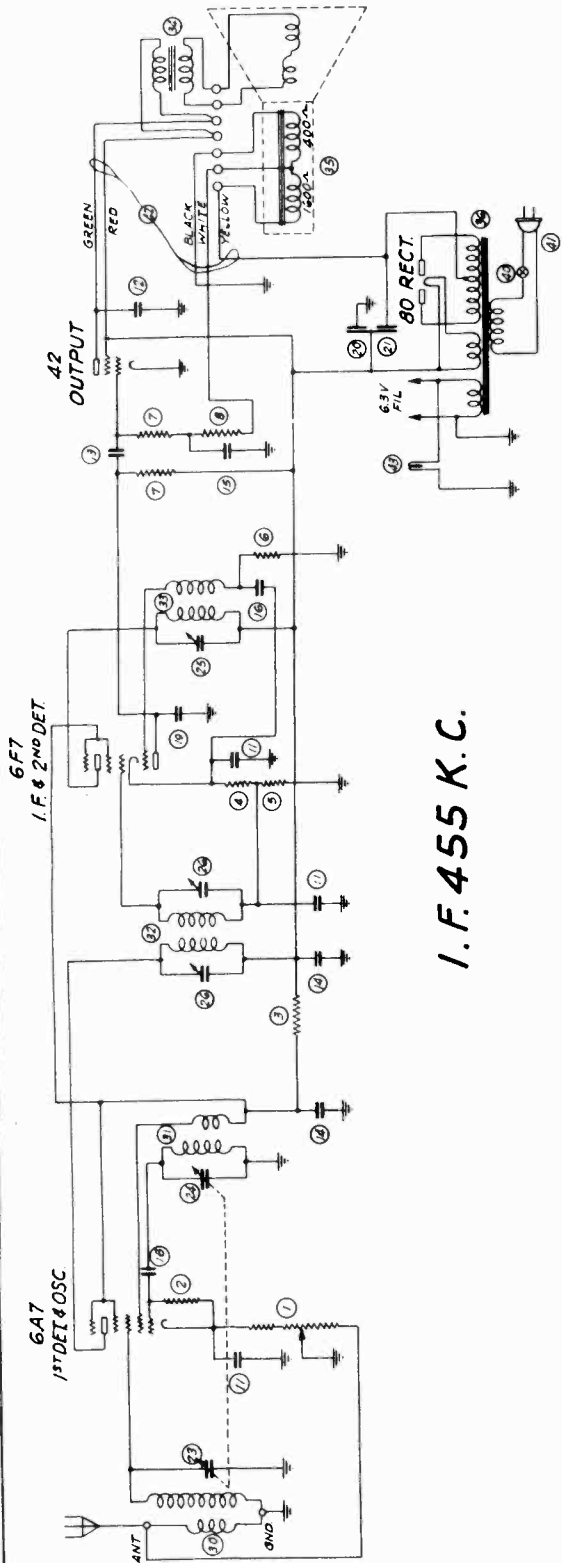

I. F. 455 K. C.

RESISTORS		PAPER CONDENSERS		ELECTROLYTIC CONDENSERS		TRANSFORMERS & CHOKES		MISCELLANEOUS	
ITEM NO	DESCRIPTION	ITEM NO	DESCRIPTION	ITEM NO	DESCRIPTION	ITEM NO	DESCRIPTION	ITEM NO	DESCRIPTION
1	3/222 VOLUME CONTROL (7500-)	3	29135 0.1 MFD ±10% 100V	20	3/208 8 MFD 350 D.C. VOLTS	30	3/284 ANT. COIL ASSEMBLY	40	3/225 LINE SWITCH
2	23853 50,000 OHM ±20% - 1/4 W	12	28720 0.005 MFD ±10% 700V	21	3/208 8 MFD 350 D.C. VOLTS	31	3/232 OSC. COIL ASSEMBLY	41	20801 LINE CORD
3	3/231 20,000 OHM ±5% 1/4 W - MHEM	15	28567 0.02 MFD ±20% 400V			32	3/235 1ST I.F. ASSEMBLY	42	3/266 SPEAKER CABLE
4	3/224 400 OHM ±10% 10 MA WIRE W	14	28726 0.1 MFD ±10% 400V			33	3/288 2ND I.F. ASSEMBLY	43	3/267 PILOT LIGHT ASSEMBLY
5	3/224 400 OHM ±10% 10 MA WIRE W	15	28728 0.25 MFD ±10% 100V			34	29-41 OUT-PUT TRANS.		
6	23858 1 MEG OHM ±20% - 1/4 W	16	30143 0.05 MFD ±10% 100V			35	29786 SPEAKER FIELD	26564	26564 TUBE SHIELD W/SE
7	23859 500,000 OHM ±20% - 1/4 W					36	3/226 POWER TRANS. (50-80-)	20942	20942 GRID CAP
8	23898 250,000 OHM ±20% - 1/4 W	MICA CONDENSERS						28366	28366 OSC. COIL MFG. STRIP ASSEM.
		23	24497 250-MMFD ±10%					31075	31075 4 PRONG SOCKET
		24	3/218 R.F. SEC. OF P. OAKG					31079	31079 6 PRONG SOCKET
		25	27582 15 TO 75 MMF					31080	31080 7 PRONG SOCKET*
		26	3/339 2000-MMFD ±10%					31172	31172 DIAL WINDOW
MISCELLANEOUS - CONTINUED									
	3/209 DIAL POINTER								
	3/211 REFLECTOR & DIAL MFG								
	3/218 JUNCTION TERM. BOARD								
	3/237 DIAL CHART								
	28010 KNOB								
	29162 TUBE SHIELD								
	3/165 883 SPEAKER								
	62570 1/4-20 X 1/2 SELF TAP SCREW								
	63839 FELT WASHERS								
	63827 FLAT WASHERS								

Grunow Radio
CHASSIS TYPE 4-B
RECEIVER MODEL 460
SPEAKER 8 B 3
GENERAL HOUSEHOLD UTILITIES CO.
RADIO SERVICE DEPARTMENT
CHICAGO, ILL.
R A S-18

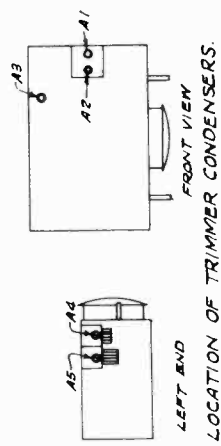

FRONT VIEW
LEFT END
LOCATION OF TRIMMER CONDENSERS.

MODEL 550 (5B)

Temporary
Schematic
Trimmers

GENERAL HOUSEHOLD UTILITIES CO.

CONDENSER KEY
A - TUBULAR
B - BLOCK

I. F. 455 K. C.

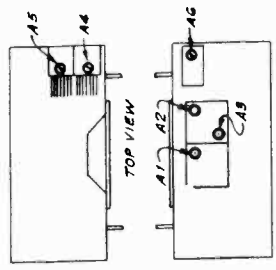
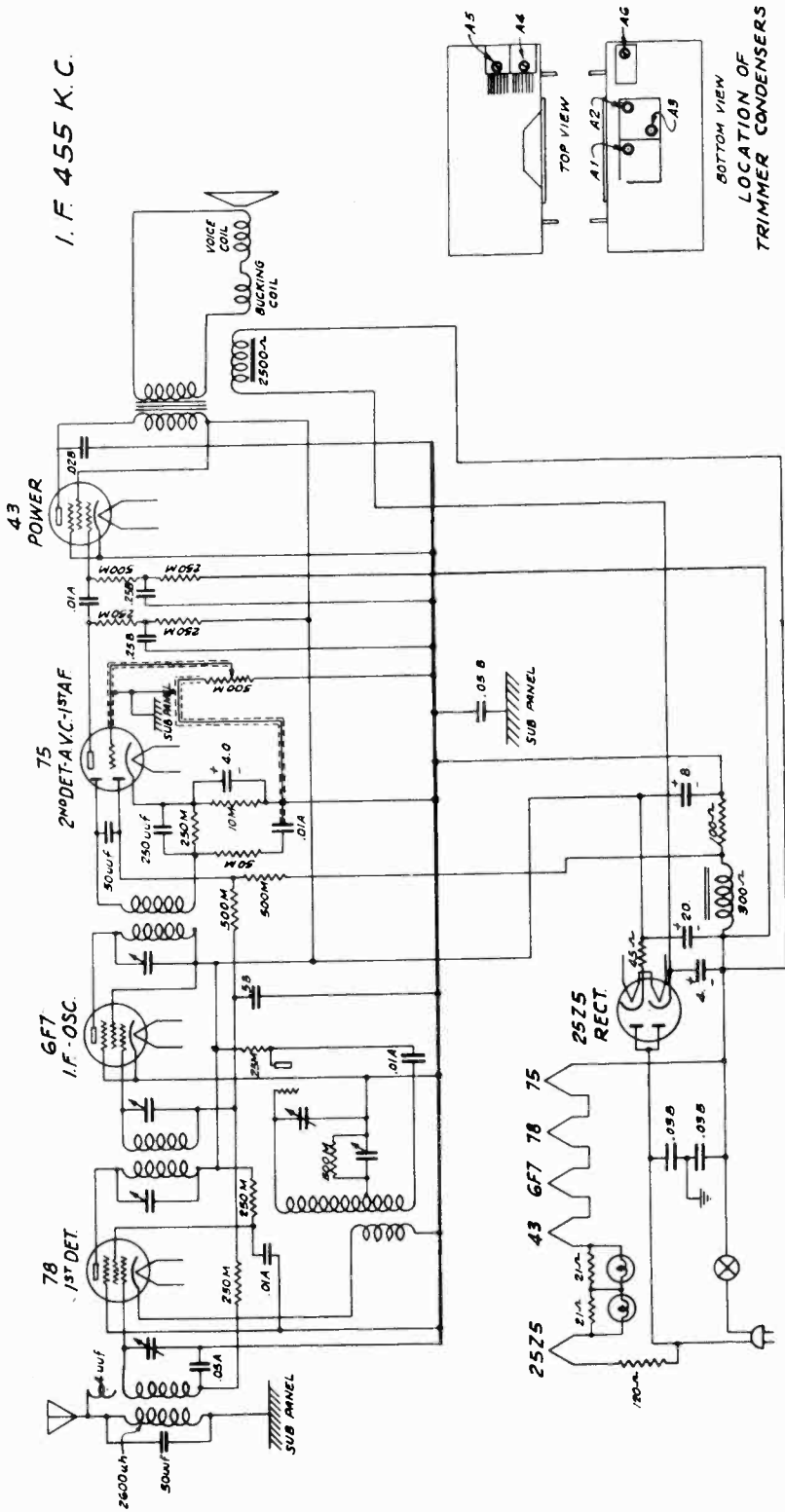

LOCATION OF TRIMMER CONDENSERS

Grunow Radio
 CHASSIS TYPE 5-B
 RECEIVER MODEL 550 5-D
 GENERAL HOUSEHOLD UTILITIES CO.
 RADIO SERVICE DEPARTMENT.
 CHICAGO, ILL.
 RAS 21

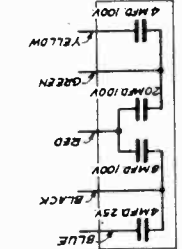

ELECTROLYTIC CONDENSER #27151

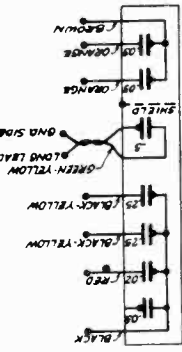

'B' CONDENSER BLOCK #28131

GENERAL HOUSEHOLD UTILITIES CO

ALIGNMENT PROCEDURE CHASSIS 6A

1. Equipment

A - Test Oscillator

A modulated oscillator capable of producing signals at 262 K.C., 455 K.C., 600 K.C., 1400 K.C., 3700 K.C., (10 M.C. and 20 M.C. used on 7B & 11A only) is necessary for alignment of the 1934 Grunow Receivers.

B - Output Meter

This may be any of the standard output meters on the market but should be sufficiently sensitive to provide a good deflection at low signal strength, and should also incorporate an adjustable shunt so that extremely strong signals may be read.

C - Coupling Means

Coupling Condensers of 200 Mmf., .25 Mfd., should be used when coupling oscillator to receiver during alignment as specified in following paragraphs.

2. Dial Setting

Turn dial knob until condensers are fully meshed. The

CHASSIS 6A - 6AW - 6AF - 6AZ

MODELS 650 - 651

Table with columns: Part No., Description, Number Required. Lists various components like Ground Terminal, Attachment Cord, Resistors, Capacitors, and their quantities.

dial pointer should be on the horizontal line of the dial.

3. I. F. Alignment

Connect signal lead of test oscillator to grid of the 6D6 (1st Detector Tube) through .25 Mfd. Condenser. Connect the ground lead to Chassis.

A - Set Dial pointer to 1400 K.C. and range switch on position "A". (Left)

B - Place test Oscillator in operation at 262 K.C. Turn receiver volume control and tone control to maximum.

C - Attenuate test oscillator out-put to lowest value consistent with obtaining a readable indication on out-put meter.

D - Adjust four I.F. Trimmers, (A1-A2-A3-A4), located on under side of Chassis, until maximum output is obtained. During alignment, maintain as low a value of signal as will allow obtaining of accurate adjustment.

4. 3700 K.C. Alignment

A - Throw range switch to position "B". (Right)

B - Connect signal lead of test oscillator to Antenna post on Chassis through 200 Mmf. Condenser.

C - Turn dial pointer to 3700 K.C.

D - Place Oscillator in operation at 3700 K.C.

E - Align Oscillator Trimmer (A5), (front trimmer located on top of variable condenser.

5. 1400 K.C. Alignment

A - Throw range switch to position "A", (Left)

B - Turn Dial pointer to 1400 K.C.

C - Place Oscillator in operation at 1400 K.C.

D - Align the 1400 K.C. Trimmer (A6), (located on the front left face of the Chassis, the lower of the two at this location).

E - Align the second and third trimmers (A7 & A8) on the top of the variable condenser.

F - Repeat the 1400 K.C. alignment at least twice.

6. 600 K.C. Alignment

A - Place Oscillator in operation at 600 K.C.

B - Tune in 600 K.C. signal (this does not have to be exactly on 600 K.C. dial setting).

C - Adjust 600 K.C. trimmer (A9), (located on the front left face of the Chassis, the upper of the two at this location), in direction of signal increase, in same time, rock the tuning condenser back and forth through resonance. Continue this procedure until maximum signal is obtained on output meter.

Table with columns: Part No., Description, Quantity. Lists various components like Tube Socket, Resistor, Capacitor, and their quantities.

MODEL 650, 651 (6A)
 Temporary
 Schematic, Trimmers

GENERAL HOUSEHOLD UTILITIES CO.

I. F. 262 K.C.

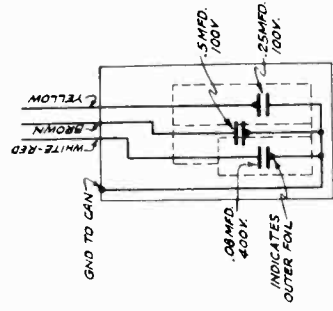
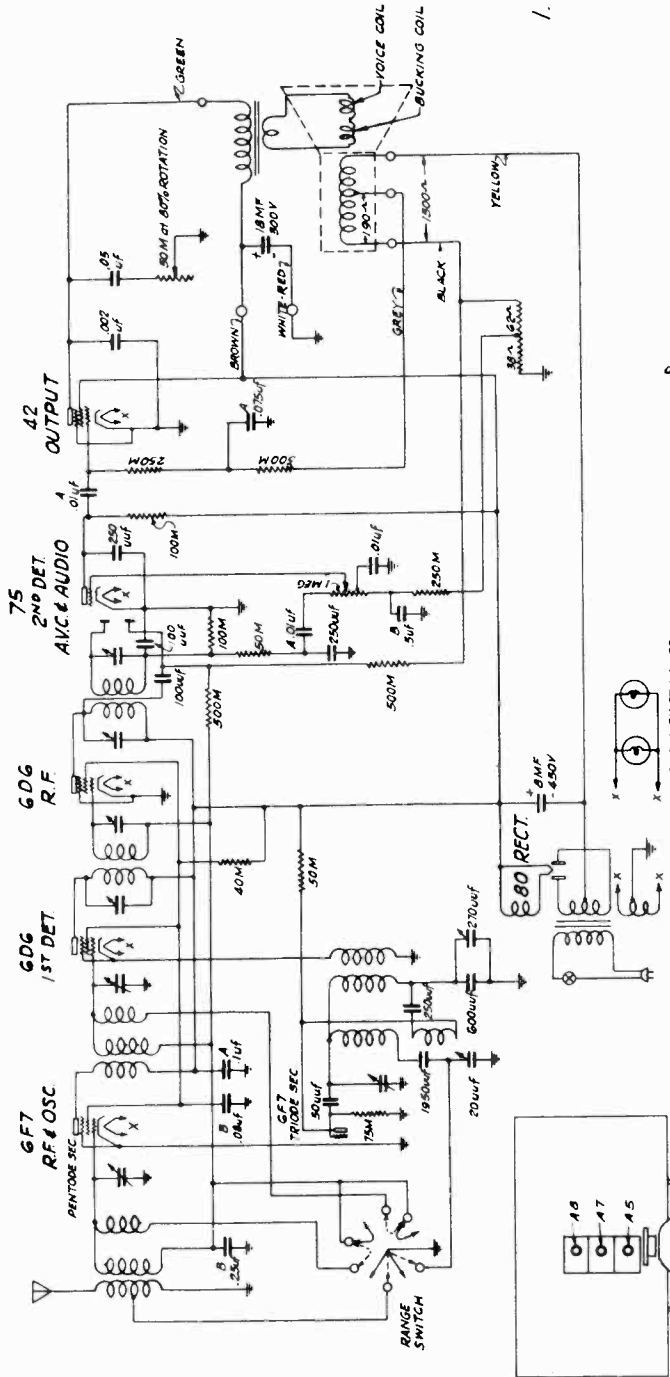

DETAIL OF
 BY-PASS CONDENSER
 #29922

CONDENSER KEY	
MARK	DESCRIPTION
"A"	TUBULAR
"B"	BY-PASS #29922

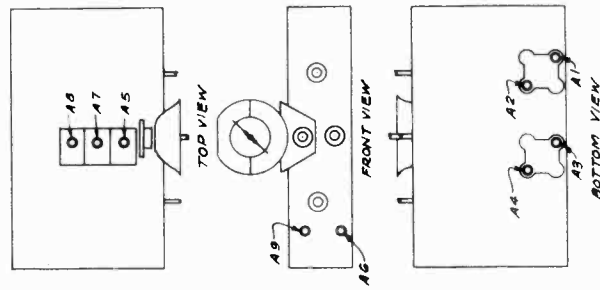

LOCATION OF TRIMMER CONDENSERS.

Grunow Radio

CHASSIS TYPE 6-A

RECEIVER MODEL SPEAKER
 650 #43-063
 651 #48-063
 GENERAL HOUSEHOLD UTILITIES CO.
 RADIO SERVICE DEPARTMENT
 CHICAGO, ILL.
 R.A.S.-22

072244

GENERAL HOUSEHOLD UTILITIES CO.

Temporary Alignment, Parts

ALIGNMENT PROCEDURE

1. Equipment

A - Test Oscillator

A modulated oscillator capable of producing signals at 262 K.C. - 600 K.C. - 1400 K.C. - 16 M.C.

B - Output Meter

This may be any of the standard output meters on the market, but should be sufficiently sensitive to provide a good deflection at low signal strength, and should also incorporate an adjustable shunt so that extremely strong signals may be read.

C - Coupling Means

Coupling condensers of 200 Mmf., 25 Mfd. and a 400 ohm resistor should be used when coupling test oscillator to receiver during alignment as specified in the following paragraphs.

2. Dial Setting

Turn dial knob until condensers are fully meshed. The dial pointer should be on the horizontal line of the dial.

3. I. F. Alignment

A. Connect signal lead of test oscillator to grid of the 6A7 (first detector tube) through a .25 Mfd. condenser. Connect the ground lead to the chassis.

B - Set dial pointer to 1400 K.C. and range switch on counter-clockwise (broadcast) position.

C - Place test oscillator in operation at 262 K.C. Turn receiver volume control and tone control to maximum.

5. 1400 K.C. Alignment

A - Turn range switch counter-clockwise to broadcast position.

B - Connect signal lead of test oscillator through 200 Mmf. condenser to antenna binding post.

C - Place test oscillator in operation at 1400 K.C. and set dial pointer on 1400 K.C.

D - Adjust the lower of the two trimmers (A1) located at the left front end of chassis and trimmers on 2nd(A8) and 3rd(A9) section of variable condensers to maximum output.

6. Recheck Operation No. 4 (16 M.C. Alignment)

7. 600 K.C. Alignment

A - Place test oscillator in operation at 600 K.C.

B - Tune in signal to maximum. (This point does not have to be exactly at 600 K.C. dial setting)

C - Adjust the 600 K.C. padding condenser (A10) (this is the upper of the two trimmers located at the left front end of chassis), in direction of signal increase; at the same time rock the tuning condenser back and forth through resonance while adjusting padding condenser until maximum output is obtained.

D - Attenuate test oscillator output to lowest value consistent with obtaining a readable indication on output meter.

E - Adjust the four I.F. trimmers (A1-A5-A3-A4) located on the under-side of the chassis, until maximum output is obtained. During alignment maintain as low a value of signal as will allow obtaining of accurate adjustment.

4. 16 M. C. ALIGNMENT

A - Connect signal lead of test oscillator through 400 ohm resistor to antenna binding post of chassis.

B - Connect the ground lead to ground terminal of chassis.

C - Set range switch to S.W. range (clockwise position).

D - Place test oscillator in operation at 16 M.C. and set dial pointer on 16 M.C.

E - Adjust trimmer (A5) on front section of variable condenser (oscillator) -- trimmer (A6) on top of detector coil and A7 on top of the antenna coil - to maximum output - (the detector and antenna coils are located on left-hand side on top of the chassis).

F - On oscillator alignment use the lower of the two images for the oscillator alignment point. It will be noted that there are two settings at which the signal will be received. Use the setting giving most capacity, that is, the setting at which the trimmer screw is farthest in. While adjusting the detector and antenna coil trimmers rock the variable condensers back and forth until maximum output is obtained.

28723	Condenser, .05 Mfd., 400 Volt Tubular
28726	Condenser, .1 Mfd., 400 Volt Tubular
28729	Condenser, .5 Mfd., 100 Volt Tubular
28925	Drive Drum Assembly
28939	Trimmer Condenser Assembly
28974	Condenser, 250-100 Mfd., Mica
28982	Condenser, 50 Mfd., Mica
28987	Tube Shield
29135	Condenser, .1 Mfd., 100 Volt Tubular
29404	Volume Control
29408	Tone Control
29409	Tuning Condenser Mounting Bracket
29410	Reflector Assembly
29428	Resistor, Cadomab
29432	Antenna Transformer
29434	1st Detector Transformer
29435	Oscillator Transformer
29453	Condenser, .01 Mfd., 400 Volt Tubular
29530	2d I.F. Transformer
29561	Antenna and Doublet Binding Posts
29567	Condenser, 8 Mfd., 450 Volt, Dry Electrolytic
29582	Condenser, 18 Mfd., 300 Volt, Wet Electrolytic
29584	Condenser, .075 Mfd., 100 Volt Tubular
29587	Condenser, .02 Mfd., 400 Volt Tubular
29589	Condenser, 480 Mfd., Mica
29590	Condenser, .02 Mfd., 400 Volt Tubular
31035	Power Transformer, 115 Volt, 60-60 Cycles
31051	Tuning Condenser, 3 Gang
31053	Power Transformer, 110-135-220-250 Volt, 50-60 Cycles
311072	Oscillator Transformer Shield
31114	Speaker Cable
31116	Resistor, 1 ohm, Ohmite
31117	Knob, Range Switch
31171	Resistor, 25,000 ohm, Carbon, 2 watt
31185	1st I.F. Transformer
31199	Drive Cable with Eyeslets
31202	Power Transformer, 115 Volts, 25-50 Cycles
31216	Drive Shaft - Outer
31154	Chassis Mounting Screw SPARKER PARTS Type 9-82
32844	Field Yoke and Pole Piece Assembly
32845	Cone Mounting Gasket
32846	Terminal Strip Assembly
32847	Terminal Strip Cover
32851	Terminal Strip Cover
32870	Speaker Complete
32971	Output Transformer
32978	Clamp Ring
32974	Field Coil
31355	Cone and Voice Coil Assembly Type 8-C4
20040	Speaker Pot Clamp
20043	Terminal Strip Cover
20058	Spider Clamp Ring
28671	Speaker Complete
29699	Speaker Pot and Pole Piece Assembly
29705	Cone Mounting Gasket
29722	Output Transformer
29727	Speaker, Field Assembly
29778	Speaker, Field Coil Assembly
31309	Cone and Voice Coil Assembly

PARTS LIST

No.	Description
22856	Resistor, 25,000 Ohm, Carbon, 1/2 watt
23284	Beckelite Washer
23558	Insulated Terminal
23570	Resistor, 100,000 Ohm, Carbon, 1/2 watt
23849	Resistor, 500,000 Ohm, Carbon, 1/2 watt
23850	Resistor, 16,000 Ohm, Carbon, 1/2 watt
23853	Resistor, 50,000 Ohm, Carbon, 1/2 watt
23856	Resistor, 250,000 Ohm, Carbon, 1/2 watt
24251	Condenser, 100 Mfd. Mica
24487	Condenser, 500 Mfd. Mica
24845	Plastic Tube, 1/8" dia. x 1/2" long
28421	Resistor, 2,000 Ohm, Carbon, 1/2 watt
28720	Condenser, .005 Mfd., 700 Volt Tubular

MODEL 660,661,662

(6C)

GENERAL HOUSEHOLD UTILITIES CO.

Temporary

Schematic, Trimmers

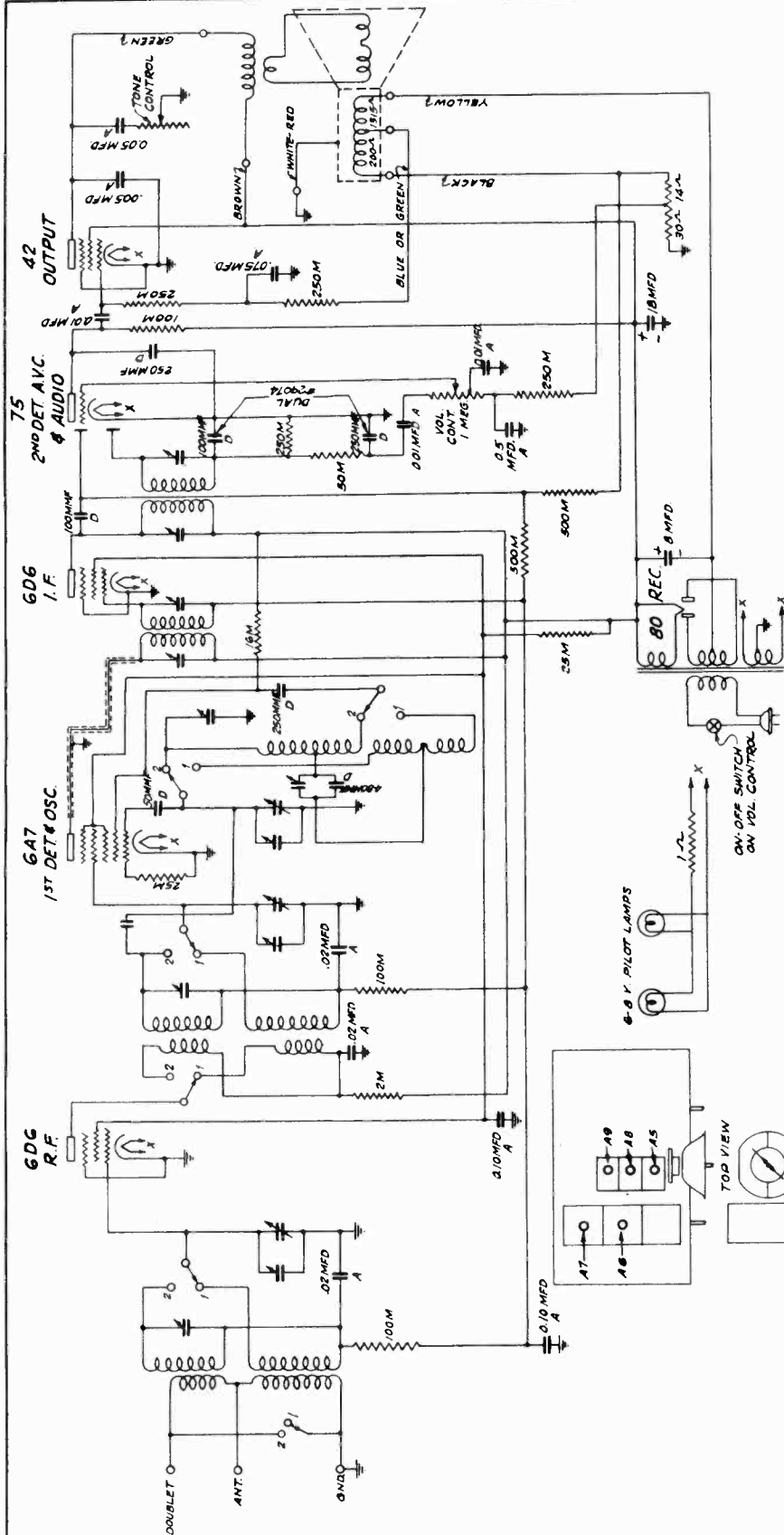

CONDENSER KEY	DESCRIPTION
A	TUBULAR (PAPER)
D	MICA

Grunow Radio

CHASSIS TYPE 6-C
 RECEIVER MODEL 660
 SPEAKER 8B2
 661
 662
 8C4
 8B2
 GENERAL HOUSEHOLD UTILITIES CO.
 RADIO SERVICE DEPARTMENT
 CHICAGO, ILL.
 RAS-20

1. F. 262 K. C.

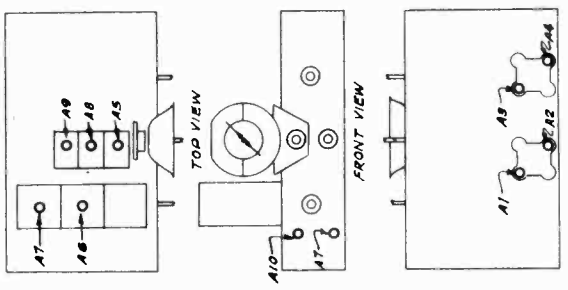

LOCATION OF TRIMMER CONDENSERS.

MODEL 670, 671 (6D)

Alignment
Temporary

GENERAL HOUSEHOLD UTILITIES CO

Oscillator through 400 ohm resistor to Antenna binding post of Chassis.

B - Connect the ground lead to ground terminal of Chassis.

C - Set Range Switch to range "0".
D - Place test Oscillator in operation at 12 M.C.

E - Adjust the following "0" range trimmers: Oscillator (A13), Detector (A14), Antenna (A15).

F - When adjusting the Detector Trimmer (A14) on the "0" range it is necessary to rock the tuning condenser in a manner similar to that required when setting the 600 K.C. Padding Condenser.

G - When adjusting the Oscillator Trimmer on the "0" range with a 12 M.C. signal it will be noted that there are two settings at which the signal will be received. Use the higher frequency setting, that is, the setting at which the trimmer screw is farthest out. On the "A", "B" and "0" range the Oscillator operates at a higher frequency than the incoming signal, and consequently the trimmer capacity will be lower when adjustment is completed.

8. 21 M.C. Alignment

A - Set Range Switch on range "D".
B - Place test Oscillator in operation at 21 M.C.

C - Turn Dial Pointer to 21 M.C.

D - Adjust the following "D" range trimmers: Oscillator (A16), Detector (A17), Antenna (A18).

E - When adjusting the Detector Trimmer (A17) on the "D" range it is necessary to rock the tuning condenser back and forth through resonance in the same manner as required when setting the 600 K.C. Padding Condenser.

F - When adjusting the Oscillator trimmer on the "D" range with a 21 M.C. signal it will be noted that there are two settings at which the signal will be received. Use the lower frequency setting, that is, the setting at which the trimmer screw is farthest in. On the "D" range the Oscillator operates at a lower frequency than the incoming signal, and consequently the trimmer capacity will be higher when adjustment is completed.

control and tone control to maximum.

C - Attenuate test Oscillator output to lowest value consistent with obtaining a readable indication on output meter.

D - Adjust five I.F. Trimmers, (A1, A2, A3, A4, A5), located on the I.F. transformers on top of the Chassis, (2 Trimmers are on top of each transformer and the fifth is at the lower side of the 1st I.F. transformer, (this is the Bi-Selector I.F. stage), until maximum output is obtained. During alignment, maintain as low a value of signal as will allow obtaining of accurate adjustment.

4. 4500 K.C. Alignment

A - Connect signal lead of test Oscillator through 200 Mmf. Condenser to Antenna binding part.

B - Connect the test Oscillator ground lead to the ground post of Chassis.

C - Turn Range Switch to range "B" and set Dial Pointer to 4500 K.C.

D - Align the following "B" range trimmers: Oscillator (A6), Detector (A7) Antenna (A8).

5. 1400 K.C. Alignment

A - Place test Oscillator in operation at 1400 K.C.

B - Turn Dial to 1400 K.C.

C - Turn Range Switch to range "A".

D - Adjust the following "A" range trimmers: Oscillator (A9), Detector (A10) Antenna (A11).

6. 600 K.C. Alignment

A - Place test Oscillator in operation at 600 K.C.

B - Tune in signal to maximum (this point does not have to be exactly at 600 K.C. setting).

C - Adjust the 600 K.C. Padding Condenser, (A12) in direction of signal increase. At same time rock the tuning condenser back and forth through resonance while adjusting Padding Condenser until maximum output is obtained.

7. 12 M.C. Alignment

A - Connect signal lead of test

SEPTEMBER 1934

Grunow Radio

TEMPORARY

SERVICE NOTES & PARTS LIST

CHASSIS TYPE 6D

RECEIVER MODELS 670 & 671

SPEAKER TYPES 8C6 10A5

GENERAL HOUSEHOLD UTILITIES CO.

CHICAGO U.S.A.

31561-1

LITHO U.S.A.

ALIGNMENT PROCEDURE CHASSIS 6D

GENERAL

The Type 6D Chassis is used in conjunction with the 8C6 speaker in receiver model 670 and with the 10A5 speaker in the model 671 receiver.

This Chassis is a 6 tube all wave (550 to 21800 K.C.) superheterodyne, using 1 - 6D6 tube as an R.F. Amplifier, 1 - 6A7 tube as first Detector and Oscillator, 1 - 6D6 tube as a Bi-Selector I.F. Amplifier, 1 - 75 tube acting as a second Detector, Automatic Volume Control and Audio Amplifier, 1 - 42 tube as the Audio Output and an 80 tube for the Rectifier.

The intermediate frequency is 455 K.C. An efficient range switch controls the four ranges in which the receiver operates.

ALIGNMENT

1. Equipment

A - Test Oscillator
A modulated Oscillator capable of producing signals at 455 K.C., 600 K.C., 1400 K.C., 4500 K.C., 12 M.C. and 21 M.C. is necessary for alignment of the Type 6D Chassis.

B - Output Meter

This may be any of the standard output meters on the market but should be sufficiently sensitive to provide a good deflection at low signal strength, and should also incorporate an adjustable shunt so that extremely strong signals may be read.

C - Coupling Means

Coupling Condensers of 200 Mmf., .25 Mfd., and a 400 Ohm resistor should be used when coupling oscillator to receiver during alignment as specified in following paragraphs.

2. Dial Setting

Turn dial knob until condensers are fully meshed. The dial pointer should be on the horizontal line of the dial.

3. I. F. Alignment

Connect signal lead of test Oscillator to grid of the 6A7 (1st Detector Tube) through .25 Mfd. Condenser. Connect the ground lead to the Chassis.

A - Set Dial pointer to 1400 K.C. and range switch on position "A". (Broadcast).

B - Place test Oscillator in operation at 455 K.C. Turn receiver volume

MODEL 670,671 (6D)

Temporary
Schematic

GENERAL HOUSEHOLD UTILITIES CO.

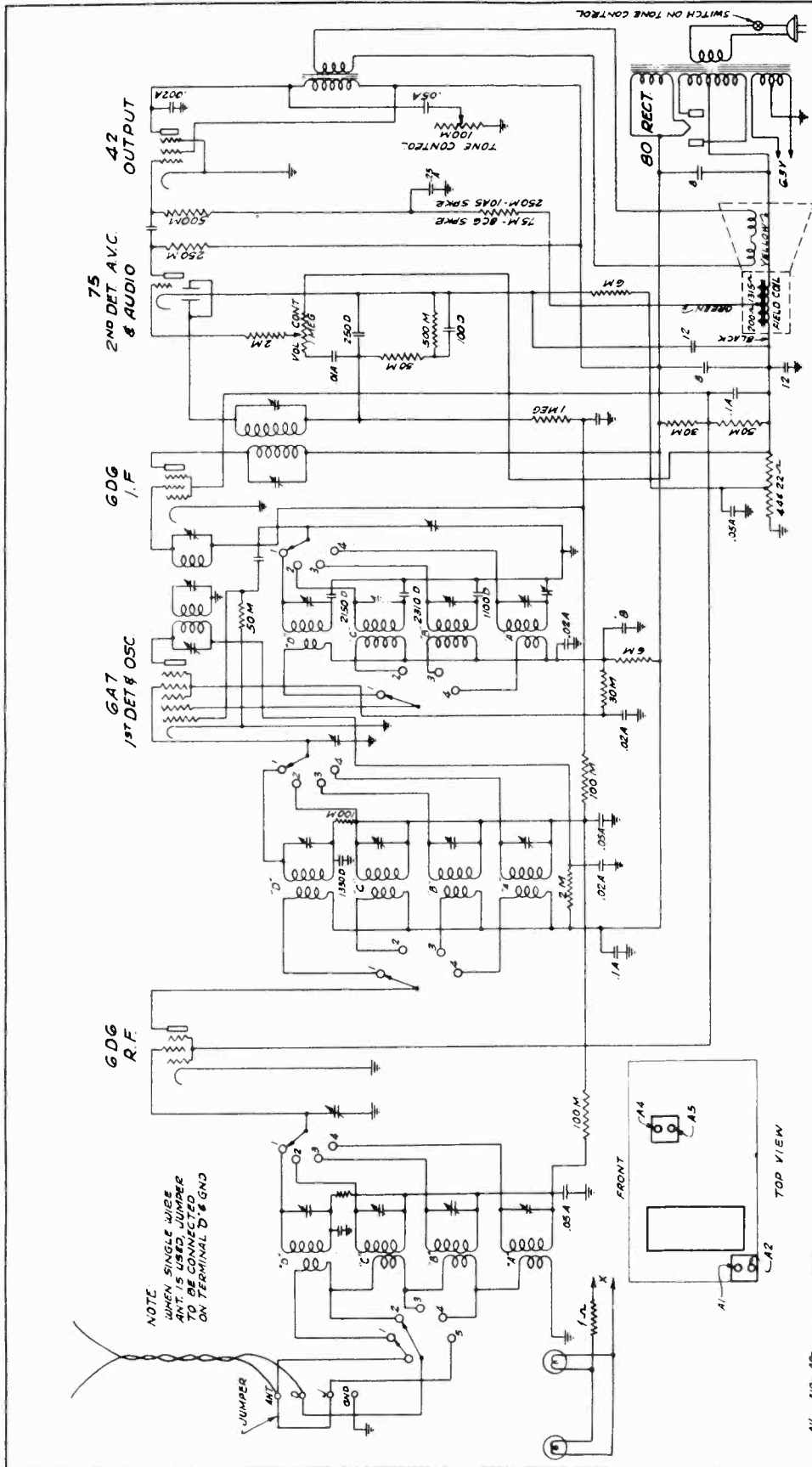

NOTE
SINGLE WIRE
WHEN 5
TO BE CONNECTED
ON TERMINAL D & GND

Grunow Radio
CHASSIS TYPE 6D
RECEIVER MODEL SPEAKER
670 8CG
671 10AS
GENERAL HOUSEHOLD UTILITIES CO.
RADIO SERVICE DEPARTMENT
CHICAGO, ILL.
RAS-17

CONDENSER KEY

MARK	DESCRIPTION	CAPACITY
A	PAPER	MF
D	MICA	MHF

1. F. 455 K. C.

- RANGE -
A - 550 - 1500 KC
B - 1600 - 4500 KC
C - 4.5 - 12.6 MC
D - 9.6 - 21.8 MC

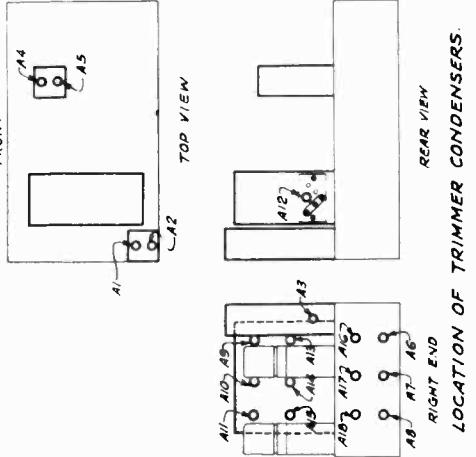

GENERAL HOUSEHOLD UTILITIES CO. MODEL 750,751,752
753 (7B) Trimmers, Coil

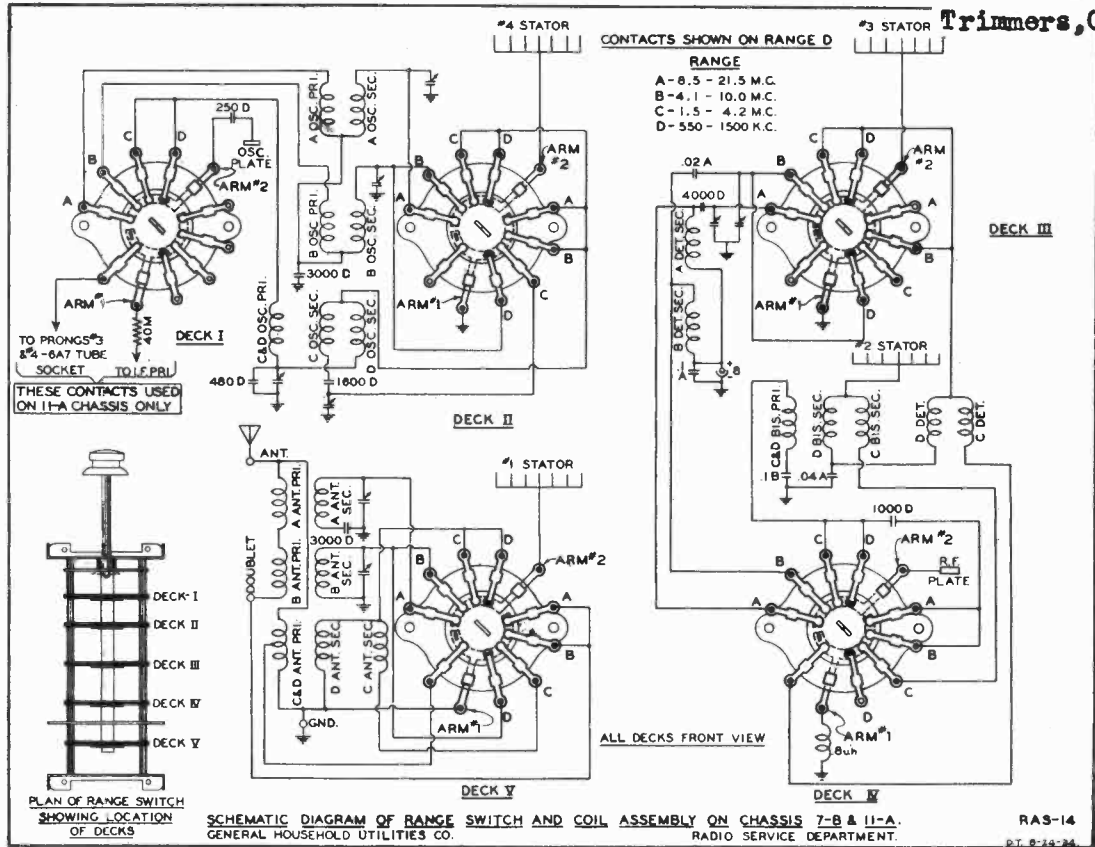
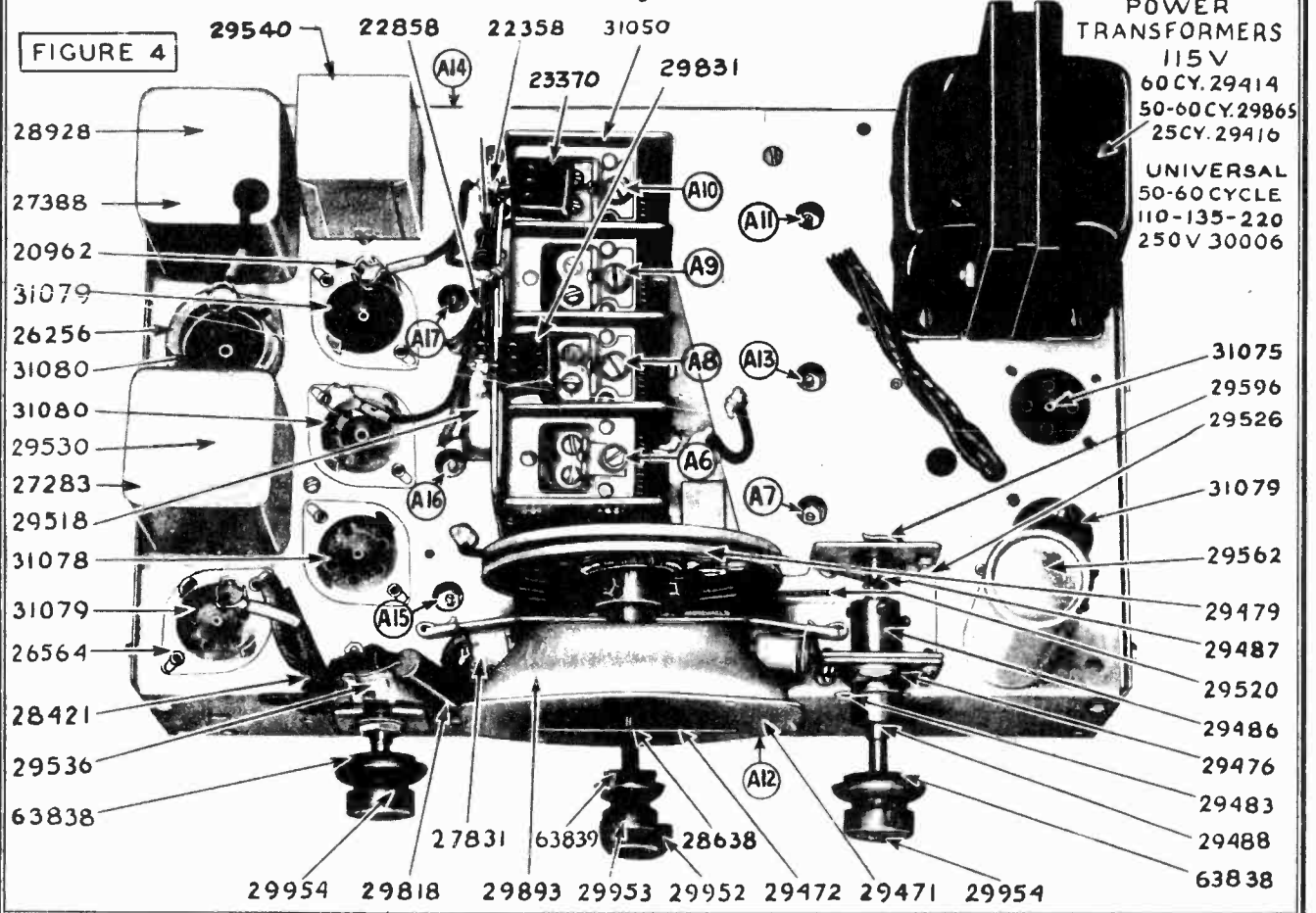

Fig. 3



MODEL 750,751,752

753 (7B)

GENERAL HOUSEHOLD UTILITIES CO.

Alignment, Parts

PARTS AND PRICE LIST

Part No.	Description	No. used	List Price
22858	Resistor, 1 Megohm, Carbon, 1/4 watt	3	.20
23284	Bakelite Washer, Trim. Condensers	13	.20
23370	Resistor, 100,000 ohm Carbon, 1/4 watt	3	.20
23849	Resistor, 500,000 ohm Carbon, 1/4 watt	3	.20
23853	Resistor, 50,000 ohm Carbon, 1/4 watt	2	.20
23998	Resistor, 250,000 ohm Carbon, 1/4 watt	4	.20
24251	Condenser, 100 Mmf. Mica	1	.15
24487	Condenser, 250 Mmf. Mica	2	.20
27283	2nd I. F. Transformer Shield	1	.35
27382	Trimmer Condenser Assembly	5	.35
27388	1st I. F. Transformer Shield	1	.20
27455	Tube Shield [Tubular]—7b	1	.15
27490	Resistor, 1,000 ohm Carbon	1	.20
28183	Resistor, 7500 ohm Carbon, 1 watt	1	.20
28421	Resistor, 2000 ohm Carbon, 1/4 watt	1	.20
28717	Condenser, .007 Mfd., 700 Volt, Tubular	1	.25
28723	Condenser, .05 Mfd., 400 Volt Tubular	1	.25
28726	Condenser, .1 Mfd., 400 Volt, Tubular	1	.25
28928	1st I. F. Transformer [includes 27388]	1	2.90
29011	Resistor, 40,000 ohm Carbon, 1 watt	1	.20
29074	Condenser, 250-100 Mmf. Mica	1	.30
29083	Condenser, 50 Mmf. Mica	1	.20
29087	Tube Shield [Goat] 6A7, 6F7, 75	3	.10
29414	Power Transformer, 115 Volt, 60 cycles only	1	6.00
29416	Power Transformer, 115 Volt, 25 to 50 cycles only	1	\$ 7.25
29453	Condensers, .01 Mfd., 400 V Tubular	1	.25
29471	Dial Chart for General Instrument Condenser only—see 30033	1	.50
29496	Antenna Transformer, Broadcast	1	1.75
29497	Bi-Selector Transformer, Broadcast	1	1.50
29498	1st Detector Transformer, Broadcast	1	1.25
29499	Oscillator Transformer, Broadcast	1	1.50
29500	Antenna Transformer, Short Wave [Rad]	1	1.75
29501	1st Detector Transformer, Short Wave [Black]	1	1.25
29502	Oscillator Transformer, Short Wave [Green]	1	1.50
29508	Trimmer Condenser Assembly — includes 29989	1	.75
29509	Range Switch and Coil Assembly	1	26.50
29515	Resistor Panel Assembly — includes 29518	1	1.25
29518	Condenser, .02-.02 Mfd. [small can]	1	.75
29523	Condenser Mounting Bearing	1	.10
29524	Cable Tension Spring	1	.10
29526	Condenser Mounting Bracket Ass'y	1	.60
29530	2nd I. F. Transformer Assembly	1	3.10
29533	Resistor, 5000-37 Ohm, Candohm	1	.40
29534	Condenser, .01 Mfd. [small can]	1	.60
29536	Volume Control, 0-1 Megohm	1	1.30

Part No.	Description	No. used	List Price
29537	Tone Control, 0-500,000 Ohm	1	\$ 1.15
29539	Oscillator Plate Choke	1	.60
29540	Bypass Condenser Block	1	2.50
29551	Antenna and Doublet Binding Post Assembly	1	.10
29552	Escutcheon Window	1	.15
29553	Window Retaining Ring	1	.10
29554	Escutcheon	1	.60
29558	Condenser, 16 Mfd., 450 Volt Dry Electrolytic	1	1.90
29559	See 31052	1	
29562	Condenser, 18 Mfd., 300 Volt Wet Electrolytic	1	1.25
29563	Resistor, 65,000 ohm Carbon, 1/2 watt	1	.20
29564	Condenser, .075 Mfd., 100 V Tubular	1	.30
29566	Condenser, 1600 Mmf. Mica	2	.30
29575	Tube Shield [Goat]	1	.10
29579	Signal Beacon Assembly	1	2.25
29580	Signal Beacon Trimmer Condenser	1	.75
29582	Signal Beacon Coil Assembly	1	1.25
29584	Signal Beacon Shield	1	.30
29596	Drive Leaf Spring	2	05
29611	Coupling Inductance Coil	1	.25
29612	Escutcheon Retaining Spring	1	.20
29613	Condenser, 4,000 Mmf. Mica	1	.50
29616	Insulated Terminal—Single	1	.10
29617	Insulated Terminal—Double	1	.15
29812	Condenser, .04 Mfd., 500 V Tubular	1	.30
29813	Condenser, .004 Mfd., 700 V Tubular	1	.25
29818	Condenser, .003 Mfd., 700 V Tubular	1	.25
29830	Condenser, 3,000 Mmf. Mica	2	.40
29831	Condenser, 1,000 Mmf. Mica	3	.30
29832	Tube Shield Body	4	.15
29836	Trimmer Condenser Assembly	1	.25
29850	Drive Drum Assembly	1	1.10
29865	Power Transformer, 115 Volt, 50-60 cycles only	1	7.00
29900	Trimmer Condenser Assembly	1	.50
29948	Insulated Terminal—Single	2	.10
29949	Insulated Terminal—Double	1	.10
29952	Knob—Range Switch	1	.30
29953	Knob—Tone Control	1	.20
29954	Knob Selector or Volume Control	2	.10
29957	Decolomania "A, B, C, D"	1	.10
29989	Condenser, 480 Mmf. Mica	1	.30
29990	Condenser, .02 Mfd., 400 V Tubular	1	.20
29997	Speaker Cable	1	.95
30006	Power Transformer, 110-135-220-250 Volt, 50-60 cycles	1	7.50

Part No.	Description	No. used	List Price
30033	Dial Chart, for Reliance Condenser only	1	.50
30034	Tuning Condenser, 4 Gang, Reliance	1	7.50
31050	Tuning Condenser, 4 Gang, General Instrument	1	7.50
31052	Condenser, 8 Mfd., 350 Volt Dry, Electrolytic	1	1.25
31075	Tube Socket—4 Prong	1	.10
31078	Tube Socket—5 Prong	1	.10
31079	Tube Socket—6 Prong	3	.15
31080	Tube Socket—7 Prong	2	.15
31215	Tube Shield Cap	4	1.10

SPEAKER PARTS

Part No.	Description	List Price
20010	TYPE 10A3—USED ON MODEL No. 751-752-753	\$ 1.15
20041	Speaker Pot & Pole Piece Assembly	1.10
20045	Terminal Strip Clamp	.15
20047	Terminal Strip Cover	.15
20047	Terminal Strip	.10
27240	Cone Gasket	.10
27591	Output Transformer	1.75
28755	Cone & Voice Assembly	3.30
29984	Field Coil Assembly	3.30
29878	Speaker Complete	11.50
20003	TYPE 8A4—USED ON MODEL No. 750	
20003	Speaker pot & pole piece assembly	.80
20040	Speaker Pot Clamp	.10
20045	Terminal Strip Cover	.15
20047	Terminal Strip	.10
29877	Speaker Complete	10.00
29897	Speaker Field Coil Assembly	2.50
29899	Speaker Pot & Pole Piece	1.20
29705	Cone Mounting Gasket	1.20
29732	Output Transformer	1.75
30058	Spider Clamp Ring	.25
31309	Cone & Voice Coil Assembly	3.10
20040	TYPE BC2—USED ON MODEL No. 750	
20040	Speaker Pot Clamp	.10
20045	Terminal Strip Cover	.15
20047	Terminal Strip	.10
29877	Speaker Complete	10.00
29897	Speaker Field Coil Assembly	2.50
29899	Speaker Pot & Pole Piece	1.20
29705	Cone Mounting Gasket	1.20
29732	Output Transformer	1.75
30058	Spider Clamp Ring	.25
31309	Cone & Voice Assembly	3.10

ALIGNMENT PROCEDURE

D—Align Set Oscillator or front trimmer A6, Fig. 4, on variable condenser. It may be necessary to approximate adjustment of the other three trimmers on variable condenser to obtain sufficient sensitivity to make 3700 K.C. adjustment.

5. 1400 K.C. ALIGNMENT:
A—Place test oscillator in operation at 1400 K.C.
B—Turn dial pointer to 1400 K.C.
C—Turn Range Switch to range D.

D—Adjust 1400 K.C. padding condenser, A7, Fig. 4, which is the first of three located on top of chassis on the right hand side as you face it.
E—Adjust 1st Det. Trimmer A8, Fig. 4, which is the second from front on top of variable condenser.
F—Adjust Bi-selector trimmer A9, Fig. 4, which is the third from front on top of variable condenser.
G—Adjust Antenna Trimmer A10, Fig. 4, which is the fourth from the front on top of variable condenser.

6.—600 K.C. ALIGNMENT:
A—Place test oscillator in operation at 600 K.C.
B—Tune in signal to maximum (this point does not have to be exactly at 600 K.C. dial setting).
C—Adjust the 600 K.C. padding condenser A11, Fig. 4, (which is on top of chassis on right hand side third from front as you face chassis), in direction of signal increases. At same time rock the tuning condenser back and forth through resonance, while adjusting padding condenser until maximum output is obtained.
7. 10 M.C. ALIGNMENT:
A—Connect signal lead of test oscillator through 400 Ohm resistor to Antenna binding post of chassis.
B—Connect the ground lead to ground terminal of chassis.
C—Set Range Switch to Range "B" and turn dial pointer to 10 M.C.
D—Place test oscillator in operation at 10 M.C.
E—Adjust set oscillator trimmer A12, Fig. 4, (located on front face of chassis).
F—Adjust detector trimmer A13, Fig. 4, (located on right hand side on top of chassis second from front).
G—Adjust antenna trimmer A14, Fig. 4, (located on rear face of chassis).
8. 20 M.C. ALIGNMENT:
A—Set Range Switch on Range A.
B—Place Test Oscillator in operation at 20 M.C.
C—Turn Dial Pointer to 20 M.C.
D—Adjust Set Oscillator trimmer A15, Fig. 4, (located on top of chassis on left of gang condenser, first from front).
E—Adjust Detector trimmer A16, Fig. 4, (located second from front on top of chassis on left hand side).
F—Adjust Antenna trimmer A17, Fig. 4, (located third from front on top of chassis on left hand side).

ALIGNMENT

Do not attempt to align the 7B chassis without the proper equipment. Alignment condensers are shown in the accompanying illustrations and are numbered in order of procedure.

1. EQUIPMENT:
A—Test Oscillator.
Signal, at 262 K.C.—600 K.C.—1400 K.C.—3700 K.C.—10 M.C. and 20 M.C. is necessary for alignment of the 7B chassis.
B—Insulated screw driver—(All bakelite or fibre) about 6" long.
C—Output Meter.

This may be any of the standard output meters on the market but should be sufficiently sensitive to provide a good deflection at low signal strength, and should also incorporate an adjustable shunt so that extremely strong signals may be read.
D—Coupling Means.
Coupling Condensers of 200 mmf., .25 Mfd., and a 400 Ohm resistor should be used when coupling oscillator to receiver during alignment as specified in the following paragraphs.
E—The receiver should be aligned in a location free from local interferences (man made static)—as high frequency disturbances may cause difficulties when the short wave section is being adjusted. (A screen room is to be recommended).

2. DIAL SETTING:
Turn dial knob until condensers are fully meshed. The dial pointer should be on the horizontal line of the dial.
3. 1. F. ALIGNMENT:
Connect signal lead of test oscillator to grid of the 6A7—(1st Detector Tube) through .25 Mfd. Condenser. Connect the ground lead to the chassis.
A—Set Dial pointer to 1400 K.C. and range switch on position D.
B—Place test Oscillator in operation at 262 K.C. Turn receiver volume control and tone control to maximum.
C—Attenuate test oscillator output to lowest value consistent with obtaining a readable indication on output meter.
D—Adjust four I. F. Trimmers, A1-A2-A3-A4 Fig. 6, located on under side of chassis, until maximum output is obtained. During alignment, maintain at low a value of signal as will allow obtaining of accurate adjustment.
E—Turn the tone control counter clockwise until the Signal Beacon switch snaps on.
F—Adjust Signal Beacon trimmer, A5, Fig. 5, which is located on left hand face of chassis to zero beat with the 262 K.C. incoming signal.

4. 3700 K.C. ALIGNMENT:
A—Connect signal lead of test oscillator through 200 Mmf condenser to Antenna binding post.
B—Connect the test oscillator ground lead to the ground post of chassis.
C—Turn range switch to range "C" and set dial pointer to 3700 K.C.

GENERAL HOUSEHOLD UTILITIES CO.

MODEL 1151, 1152
(11A)

Temporary
Schematic

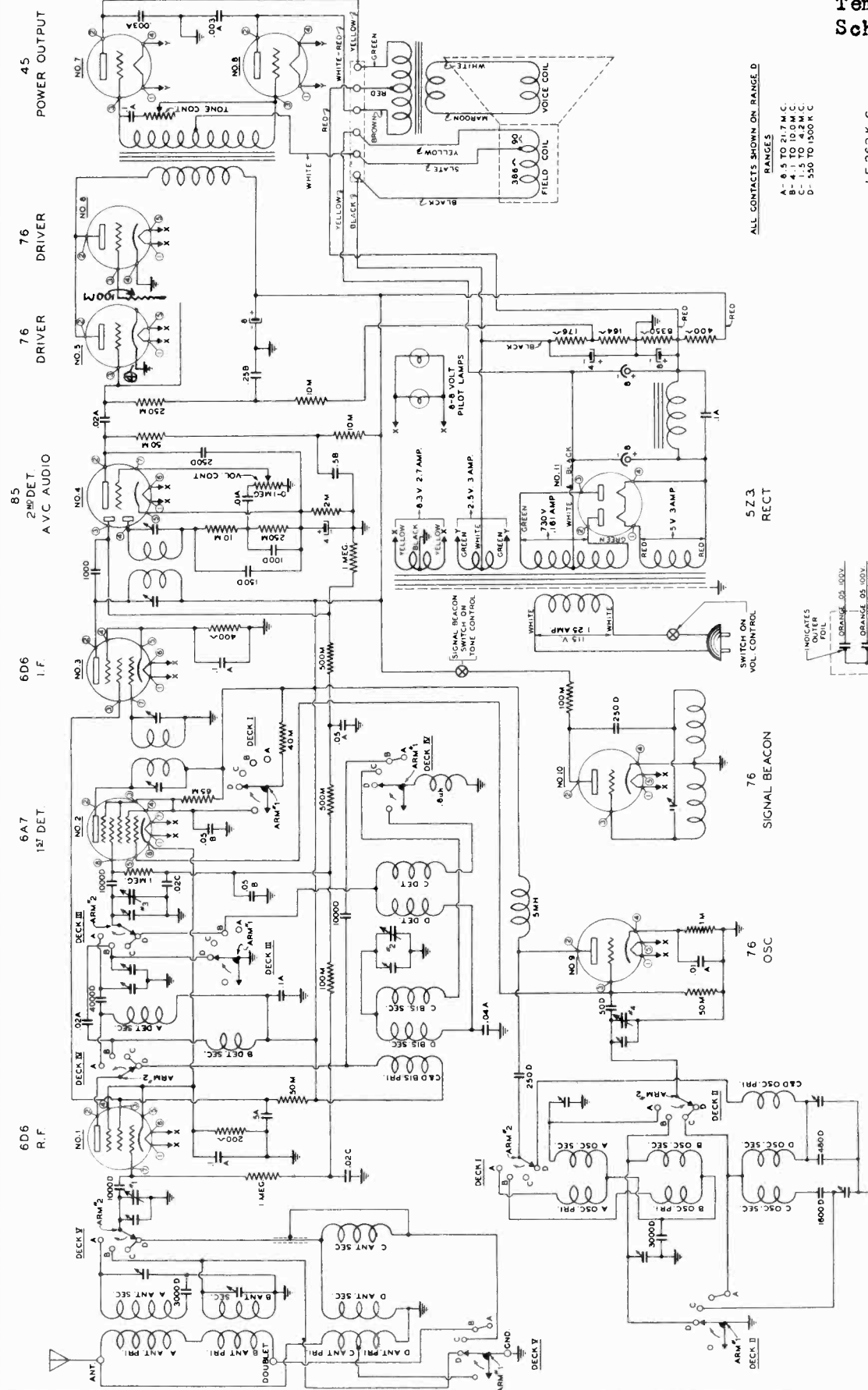

ALL CONTACTS SHOWN ON RANGE D

- RANGES
- A - 4 TO 12 M.C.
 - B - 3 TO 12 M.C.
 - C - 1.5 TO 14 M.C.
 - D - 550 TO 1500 K.C.

Grunow Radio
CHASSIS TYPE 11-A
RECEIVER MODEL 1151 12 A3
1152 10 A4
GENERAL HOUSEHOLD UTILITIES CO.
RADIO SERVICE DEPARTMENT
CHICAGO U. S. A. PAS 23

CONDENSER KEY	CONDENSER CAPACITY	TUBULAR	M.F.
A	1000		M.F.
B	1000		M.F.
C	1000		M.F.
D	1000		M.F.

573 RECT

76 SIGNAL BEACON

76 OSC

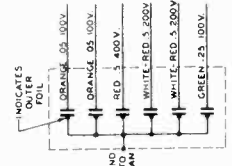

DIAGRAM OF BLOCK CONDENSER (B)
28937

MODEL 1151, 1152

(11A)

GENERAL HOUSEHOLD UTILITIES CO.

Temporary Parts
Alignment

Part No.	Description
2247	Resistor, 10,000 Ohm Carbon, 1/2 watt
2248	Resistor, 100,000 Ohm Carbon, 1/2 watt
2249	Resistor, 1,000 Ohm Carbon, 1/2 watt
2250	Resistor, 10,000 Ohm Carbon, 1/2 watt
2251	Resistor, 50,000 Ohm Carbon, 1/2 watt
2252	Resistor, 100,000 Ohm Carbon, 1/2 watt
2253	Resistor, 200,000 Ohm Carbon, 1/2 watt
2254	Condenser, 250 Mf. Mica
2255	Condenser, 250 Mf. Mica
2256	Condenser, 4 Mf. .25 Volt Dry Electrolytic
2257	Condenser, 8 Mf. .75 Volt Dry Electrolytic
2258	Condenser, 8 Mf. .75 Volt Dry Electrolytic
2259	Condenser, 4 Mf. 50 Volt - 6 Mf. 100
2260	Resistor, 1,000 Ohm Carbon, 1/2 watt
2261	Resistor, 2,000 Ohm Carbon, 1/2 watt
2262	Short Wave Coil Shield Assembly
2263	Condenser, .02 Mfd. 400 Volt tubular
2264	1st I.F. Transformer (Includes 27368)
2265	Condenser, 250 Mf. Mica
2266	Condenser, 250 Mf. Mica
2267	Condenser, 250 Mf. Mica
2268	Condenser, 250 Mf. Mica
2269	Condenser, .01 Mfd. 400 Volt tubular
2270	Condenser, .01 Mfd. 400 Volt tubular
2271	Autotransformer - Broadband
2272	1st Detector Transformer - Broadband
2273	Oscillator Transformer - Broadband
2274	1st Detector Transformer - Broadband
2275	1st Detector Transformer - Broadband
2276	1st Detector Transformer - Broadband
2277	Oscillator Transformer - Short Wave
2278	Oscillator Transformer - Short Wave
2279	Oscillator Transformer - Short Wave
2280	Oscillator Transformer - Short Wave
2281	Reflector Panel Assembly - Includes 2989
2282	Reflector Panel Assembly - Includes 2918
2283	Condenser, .02-.05 Mfd. tubular Type
2284	Resistor, 45,000 Ohm Carbon, 1/2 watt
2285	Condenser, 1,000 Mf. Mica
2286	Condenser, 1,000 Mf. Mica
2287	Signal Beacon Trimmer Condenser
2288	Signal Beacon Trimmer Condenser
2289	Signal Beacon Trimmer Condenser
2290	Signal Beacon Trimmer Condenser
2291	Signal Beacon Trimmer Condenser
2292	Signal Beacon Trimmer Condenser
2293	Signal Beacon Trimmer Condenser
2294	Signal Beacon Trimmer Condenser
2295	Signal Beacon Trimmer Condenser
2296	Signal Beacon Trimmer Condenser
2297	Signal Beacon Trimmer Condenser
2298	Signal Beacon Trimmer Condenser
2299	Signal Beacon Trimmer Condenser
2300	Signal Beacon Trimmer Condenser
2301	Signal Beacon Trimmer Condenser
2302	Signal Beacon Trimmer Condenser
2303	Signal Beacon Trimmer Condenser
2304	Signal Beacon Trimmer Condenser
2305	Signal Beacon Trimmer Condenser
2306	Signal Beacon Trimmer Condenser
2307	Signal Beacon Trimmer Condenser
2308	Signal Beacon Trimmer Condenser
2309	Signal Beacon Trimmer Condenser
2310	Signal Beacon Trimmer Condenser
2311	Signal Beacon Trimmer Condenser
2312	Signal Beacon Trimmer Condenser
2313	Signal Beacon Trimmer Condenser
2314	Signal Beacon Trimmer Condenser
2315	Signal Beacon Trimmer Condenser
2316	Signal Beacon Trimmer Condenser
2317	Signal Beacon Trimmer Condenser
2318	Signal Beacon Trimmer Condenser
2319	Signal Beacon Trimmer Condenser
2320	Signal Beacon Trimmer Condenser
2321	Signal Beacon Trimmer Condenser
2322	Signal Beacon Trimmer Condenser
2323	Signal Beacon Trimmer Condenser
2324	Signal Beacon Trimmer Condenser
2325	Signal Beacon Trimmer Condenser
2326	Signal Beacon Trimmer Condenser
2327	Signal Beacon Trimmer Condenser
2328	Signal Beacon Trimmer Condenser
2329	Signal Beacon Trimmer Condenser
2330	Signal Beacon Trimmer Condenser
2331	Signal Beacon Trimmer Condenser
2332	Signal Beacon Trimmer Condenser
2333	Signal Beacon Trimmer Condenser
2334	Signal Beacon Trimmer Condenser
2335	Signal Beacon Trimmer Condenser
2336	Signal Beacon Trimmer Condenser
2337	Signal Beacon Trimmer Condenser
2338	Signal Beacon Trimmer Condenser
2339	Signal Beacon Trimmer Condenser
2340	Signal Beacon Trimmer Condenser
2341	Signal Beacon Trimmer Condenser
2342	Signal Beacon Trimmer Condenser
2343	Signal Beacon Trimmer Condenser
2344	Signal Beacon Trimmer Condenser
2345	Signal Beacon Trimmer Condenser
2346	Signal Beacon Trimmer Condenser
2347	Signal Beacon Trimmer Condenser
2348	Signal Beacon Trimmer Condenser
2349	Signal Beacon Trimmer Condenser
2350	Signal Beacon Trimmer Condenser
2351	Signal Beacon Trimmer Condenser
2352	Signal Beacon Trimmer Condenser
2353	Signal Beacon Trimmer Condenser
2354	Signal Beacon Trimmer Condenser
2355	Signal Beacon Trimmer Condenser
2356	Signal Beacon Trimmer Condenser
2357	Signal Beacon Trimmer Condenser
2358	Signal Beacon Trimmer Condenser
2359	Signal Beacon Trimmer Condenser
2360	Signal Beacon Trimmer Condenser
2361	Signal Beacon Trimmer Condenser
2362	Signal Beacon Trimmer Condenser
2363	Signal Beacon Trimmer Condenser
2364	Signal Beacon Trimmer Condenser
2365	Signal Beacon Trimmer Condenser
2366	Signal Beacon Trimmer Condenser
2367	Signal Beacon Trimmer Condenser
2368	Signal Beacon Trimmer Condenser
2369	Signal Beacon Trimmer Condenser
2370	Signal Beacon Trimmer Condenser
2371	Signal Beacon Trimmer Condenser
2372	Signal Beacon Trimmer Condenser
2373	Signal Beacon Trimmer Condenser
2374	Signal Beacon Trimmer Condenser
2375	Signal Beacon Trimmer Condenser
2376	Signal Beacon Trimmer Condenser
2377	Signal Beacon Trimmer Condenser
2378	Signal Beacon Trimmer Condenser
2379	Signal Beacon Trimmer Condenser
2380	Signal Beacon Trimmer Condenser
2381	Signal Beacon Trimmer Condenser
2382	Signal Beacon Trimmer Condenser
2383	Signal Beacon Trimmer Condenser
2384	Signal Beacon Trimmer Condenser
2385	Signal Beacon Trimmer Condenser
2386	Signal Beacon Trimmer Condenser
2387	Signal Beacon Trimmer Condenser
2388	Signal Beacon Trimmer Condenser
2389	Signal Beacon Trimmer Condenser
2390	Signal Beacon Trimmer Condenser
2391	Signal Beacon Trimmer Condenser
2392	Signal Beacon Trimmer Condenser
2393	Signal Beacon Trimmer Condenser
2394	Signal Beacon Trimmer Condenser
2395	Signal Beacon Trimmer Condenser
2396	Signal Beacon Trimmer Condenser
2397	Signal Beacon Trimmer Condenser
2398	Signal Beacon Trimmer Condenser
2399	Signal Beacon Trimmer Condenser
2400	Signal Beacon Trimmer Condenser
2401	Signal Beacon Trimmer Condenser
2402	Signal Beacon Trimmer Condenser
2403	Signal Beacon Trimmer Condenser
2404	Signal Beacon Trimmer Condenser
2405	Signal Beacon Trimmer Condenser
2406	Signal Beacon Trimmer Condenser
2407	Signal Beacon Trimmer Condenser
2408	Signal Beacon Trimmer Condenser
2409	Signal Beacon Trimmer Condenser
2410	Signal Beacon Trimmer Condenser
2411	Signal Beacon Trimmer Condenser
2412	Signal Beacon Trimmer Condenser
2413	Signal Beacon Trimmer Condenser
2414	Signal Beacon Trimmer Condenser
2415	Signal Beacon Trimmer Condenser
2416	Signal Beacon Trimmer Condenser
2417	Signal Beacon Trimmer Condenser
2418	Signal Beacon Trimmer Condenser
2419	Signal Beacon Trimmer Condenser
2420	Signal Beacon Trimmer Condenser
2421	Signal Beacon Trimmer Condenser
2422	Signal Beacon Trimmer Condenser
2423	Signal Beacon Trimmer Condenser
2424	Signal Beacon Trimmer Condenser
2425	Signal Beacon Trimmer Condenser
2426	Signal Beacon Trimmer Condenser
2427	Signal Beacon Trimmer Condenser
2428	Signal Beacon Trimmer Condenser
2429	Signal Beacon Trimmer Condenser
2430	Signal Beacon Trimmer Condenser
2431	Signal Beacon Trimmer Condenser
2432	Signal Beacon Trimmer Condenser
2433	Signal Beacon Trimmer Condenser
2434	Signal Beacon Trimmer Condenser
2435	Signal Beacon Trimmer Condenser
2436	Signal Beacon Trimmer Condenser
2437	Signal Beacon Trimmer Condenser
2438	Signal Beacon Trimmer Condenser
2439	Signal Beacon Trimmer Condenser
2440	Signal Beacon Trimmer Condenser
2441	Signal Beacon Trimmer Condenser
2442	Signal Beacon Trimmer Condenser
2443	Signal Beacon Trimmer Condenser
2444	Signal Beacon Trimmer Condenser
2445	Signal Beacon Trimmer Condenser
2446	Signal Beacon Trimmer Condenser
2447	Signal Beacon Trimmer Condenser
2448	Signal Beacon Trimmer Condenser
2449	Signal Beacon Trimmer Condenser
2450	Signal Beacon Trimmer Condenser
2451	Signal Beacon Trimmer Condenser
2452	Signal Beacon Trimmer Condenser
2453	Signal Beacon Trimmer Condenser
2454	Signal Beacon Trimmer Condenser
2455	Signal Beacon Trimmer Condenser
2456	Signal Beacon Trimmer Condenser
2457	Signal Beacon Trimmer Condenser
2458	Signal Beacon Trimmer Condenser
2459	Signal Beacon Trimmer Condenser
2460	Signal Beacon Trimmer Condenser
2461	Signal Beacon Trimmer Condenser
2462	Signal Beacon Trimmer Condenser
2463	Signal Beacon Trimmer Condenser
2464	Signal Beacon Trimmer Condenser
2465	Signal Beacon Trimmer Condenser
2466	Signal Beacon Trimmer Condenser
2467	Signal Beacon Trimmer Condenser
2468	Signal Beacon Trimmer Condenser
2469	Signal Beacon Trimmer Condenser
2470	Signal Beacon Trimmer Condenser
2471	Signal Beacon Trimmer Condenser
2472	Signal Beacon Trimmer Condenser
2473	Signal Beacon Trimmer Condenser
2474	Signal Beacon Trimmer Condenser
2475	Signal Beacon Trimmer Condenser
2476	Signal Beacon Trimmer Condenser
2477	Signal Beacon Trimmer Condenser
2478	Signal Beacon Trimmer Condenser
2479	Signal Beacon Trimmer Condenser
2480	Signal Beacon Trimmer Condenser
2481	Signal Beacon Trimmer Condenser
2482	Signal Beacon Trimmer Condenser
2483	Signal Beacon Trimmer Condenser
2484	Signal Beacon Trimmer Condenser
2485	Signal Beacon Trimmer Condenser
2486	Signal Beacon Trimmer Condenser
2487	Signal Beacon Trimmer Condenser
2488	Signal Beacon Trimmer Condenser
2489	Signal Beacon Trimmer Condenser
2490	Signal Beacon Trimmer Condenser
2491	Signal Beacon Trimmer Condenser
2492	Signal Beacon Trimmer Condenser
2493	Signal Beacon Trimmer Condenser
2494	Signal Beacon Trimmer Condenser
2495	Signal Beacon Trimmer Condenser
2496	Signal Beacon Trimmer Condenser
2497	Signal Beacon Trimmer Condenser
2498	Signal Beacon Trimmer Condenser
2499	Signal Beacon Trimmer Condenser
2500	Signal Beacon Trimmer Condenser

ALIGNMENT PROCEDURE
CHASSIS TYPE 11A

1. Equipment.
 - A - Test Oscillator
A modulated oscillator capable of producing signals at 252 K.C., 455 K.C., 600 K.C., 1400 K.C., 3700 K.C., 10 M.C. and 20 M.C. is necessary for alignment of the 1154 Grunow Receivers.
 - B - Output Meter
This may be any of the standard output meters on the market but should be sufficiently sensitive to provide a good deflection at low signal strength and should also incorporate an adjustable shunt so that extremely strong signals may be read.
 - C - Coupling Means
Coupling Condensers of 200 Mf., .25 Mfd., and a 400 Ohm resistor should be used when coupling oscillator to receiver during alignment as specified in following paragraphs.
 - D. Dial Setting.
Turn dial knob until condensers are fully meshed. The dial pointer should be on the horizontal line of the dial.
 5. I. F. Alignment.
Connect signal lead of test oscillator to grid of the 6A7 (1st Detector Tube) through .25 Mfd. Condenser. Connect the ground lead to the Chassis.
A - Set Dial pointer to 1400 K.C. and range switch on position D.
B - Place Test Oscillator in operation at 252 K.C. Turn receiver volume control and tone control to maximum.
C - Attenuate test oscillator output to lowest value consistent with obtaining a readable indication on output meter.
D - Adjust four I. F. Trimmers, located on under side of chassis, until maximum output is obtained. During alignment, maintain as low a value of signal as will allow obtaining of accurate adjustment.
E - Turn the tone control clockwise until the beat oscillator switch snaps on.
- F - Adjust beat oscillator trimmer of Chassis to zero beat with the 252 K.C. incoming signal.
4. 3700 K.C. Alignment.
A - Connect signal lead of test oscillator through 200 Mf. condenser to Antenna binding post.
- B - Connect the test oscillator ground lead to the ground post of Chassis.
- C - Turn range switch to range "C" and set dial pointer to 3700 K.C.
- D - Align Set Oscillator or trimmer on variable condenser. It may be necessary to approximate adjustment of the other three trimmers on variable condenser to obtain sufficient sensitivity to make 3700 K.C. adjustment.
5. 1400 K.C. Alignment.
A - Place test oscillator in operation at 1400 K.C.
B - Turn dial to 1400 K.C.
C - Turn Range Switch to range D.
D - Adjust 1400 K.C. padding condenser, which is the first of three located on top of Chassis on the right hand side as you face it.
E - Adjust 1st Det. Trimmer which is the second from front on top of variable condenser.
F - Adjust Bi-selector Trimmer which is the third from front on top of variable condenser.
G - Adjust Antenna Trimmer which is the fourth from the front on top of variable condenser.
6. 600 K.C. Alignment.
A - Place test oscillator in operation at 600 K.C.
B - Tune in signal to maximum (this point does not have to be exactly at 600 K.C. dial setting).
- C - Adjust the 600 K.C. padding Condenser (which is on top of Chassis on right hand side third from front as you face Chassis), in direction of signal increase. At same time rock the tuning condenser back and forth through resonance while adjusting padding condenser until maximum output is obtained.
7. 10 M.C. Alignment.
A - Connect signal lead of test oscillator through 400 Ohm resistor to Antenna binding post of Chassis.
B - Connect the ground to lead to ground terminal of Chassis.
C - Set Range Switch to Range "B".
D - Place test oscillator in operation at 10 M.C.
E - Adjust set oscillator trimmer (located on front face of Chassis).
F - Adjust detector trimmer (located on right hand side on top of Chassis second from front).
G - Adjust antenna trimmer (located on rear face of Chassis).
8. 20 M.C. Alignment.
A - Set Range Switch on Range A.
B - Place Test Oscillator in operation at 20 M.C.
C - Turn Dial Pointer to 20 M.C.
D - Adjust Set Oscillator trimmer. (Located on top of Chassis on left of gang condenser, first from front).
E - Adjust Detector trimmer (located second from front on top of Chassis on left hand side).
F - Adjust Antenna trimmer (located third from front on top of Chassis on left hand side).

MODEL 901,902 (9A)
(Revised)
GENERAL HOUSEHOLD UTILITIES CO Schematic

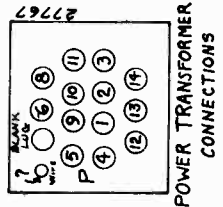
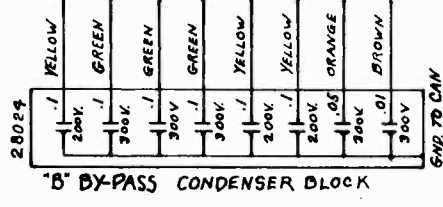
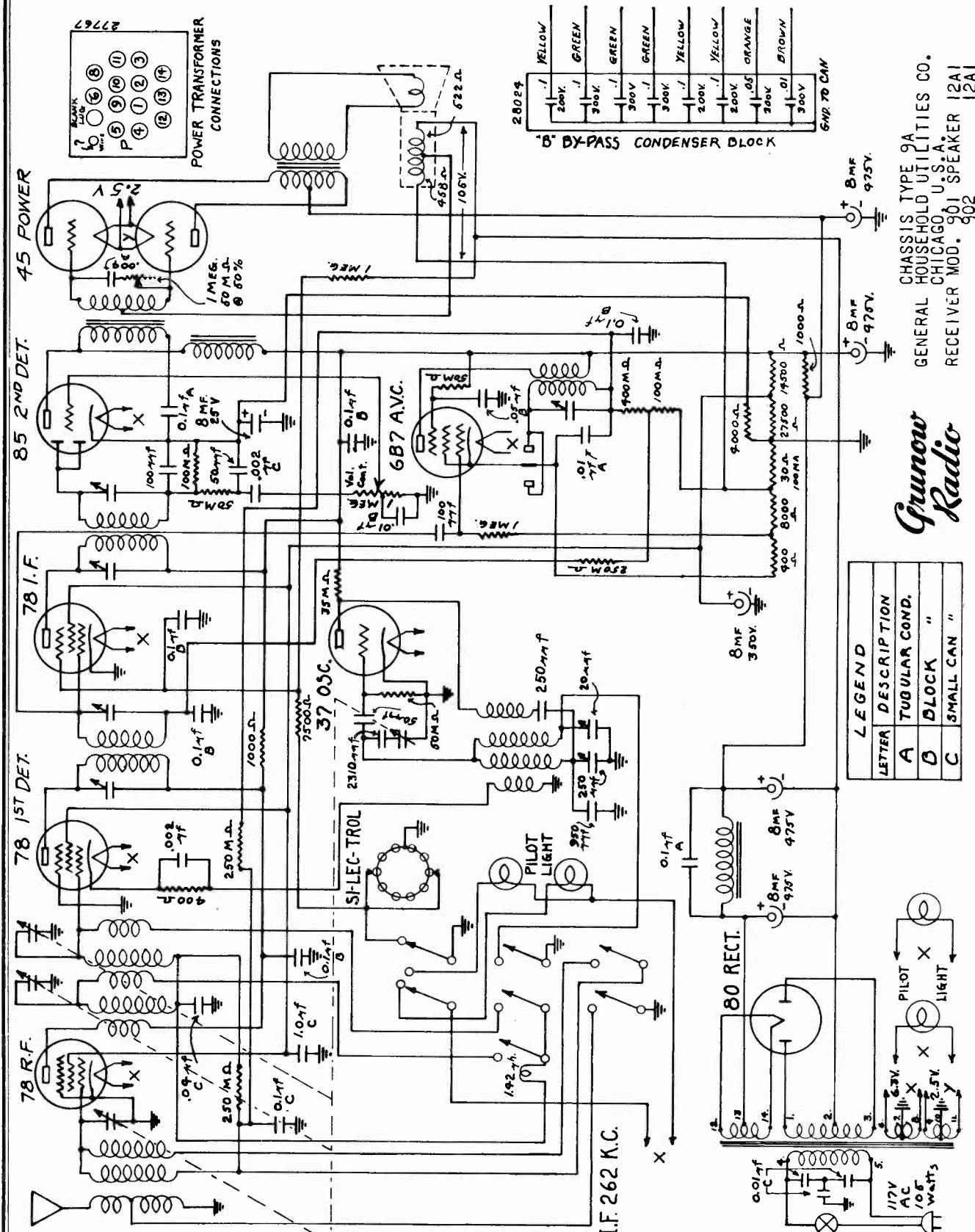

LEGEND

LETTER	DESCRIPTION
A	TUBULAR COND.
B	BLOCK "
C	SMALL CAN "

Grunow
Radio

CHASSIS TYPE 9A
GENERAL HOUSEHOLD UTILITIES CO.
CHICAGO, U.S.A.
RECEIVER MOD. 901 SPEAKER 12A1

MODEL 1101 (9B-2A)

(Revised)

Schematic

GENERAL HOUSEHOLD UTILITIES CO.

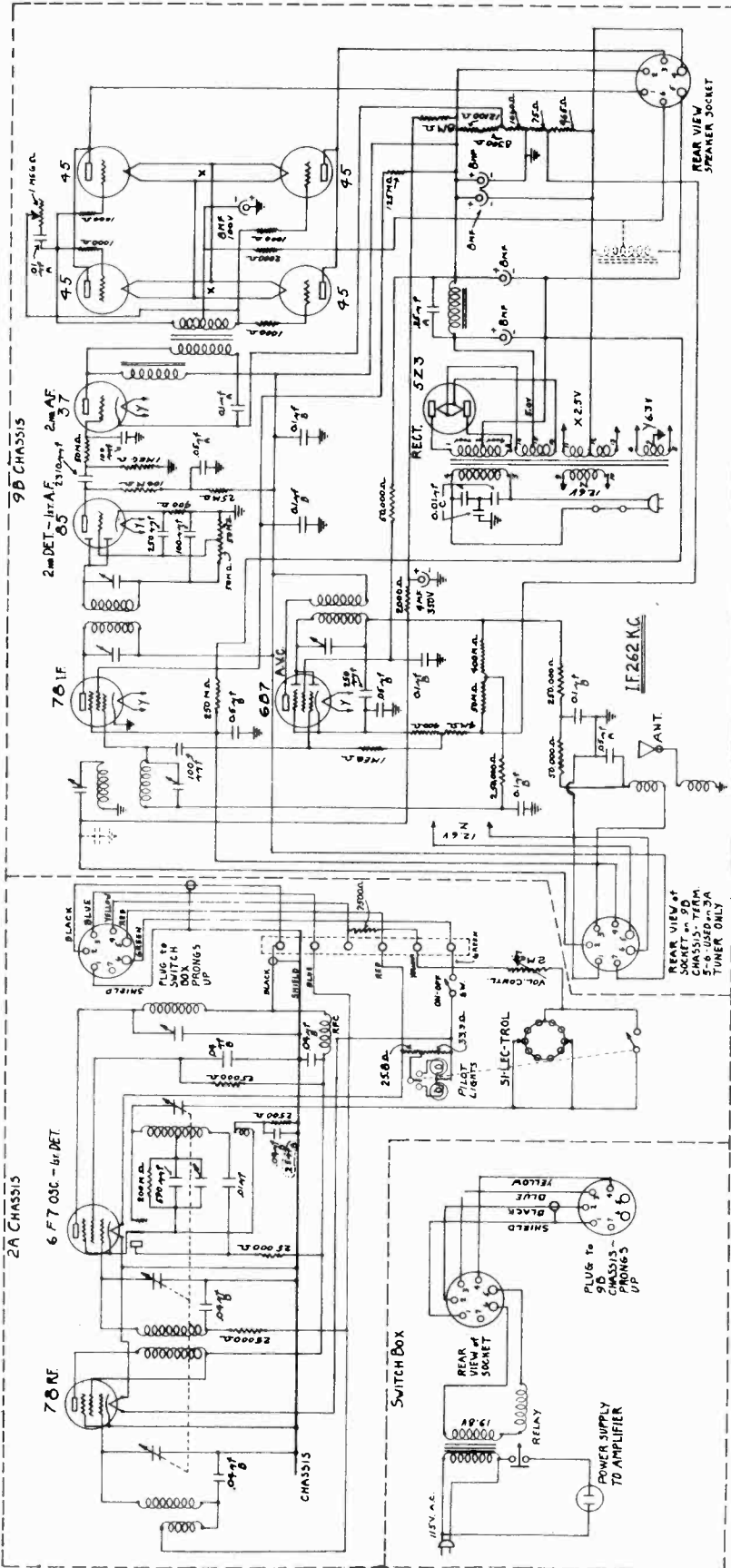

Grunow Radio
 GRUNOW MODEL 1101
 GENERAL HOUSEHOLD UTILITIES CO.
 CHICAGO, U.S.A.
 CHASSIS TYPE 9B AND 2A
 SPEAKER TYPE 12A2

PH 15-20-33

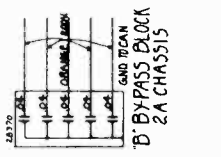
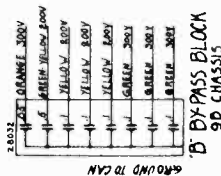
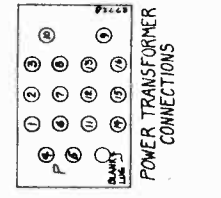
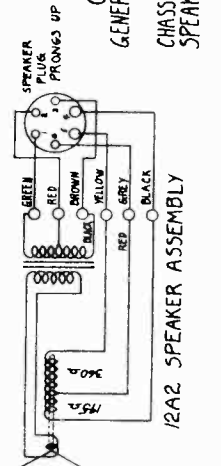

- CONDENSER DESCRIPTION
 A. TUBULAR
 B. BLOCK
 C. SMALL CAN

Corrected Diagram

GENERAL MOTORS RADIO CORP.

MODEL 292, 293
(S4-A, S4-B)
Schematic, Socket

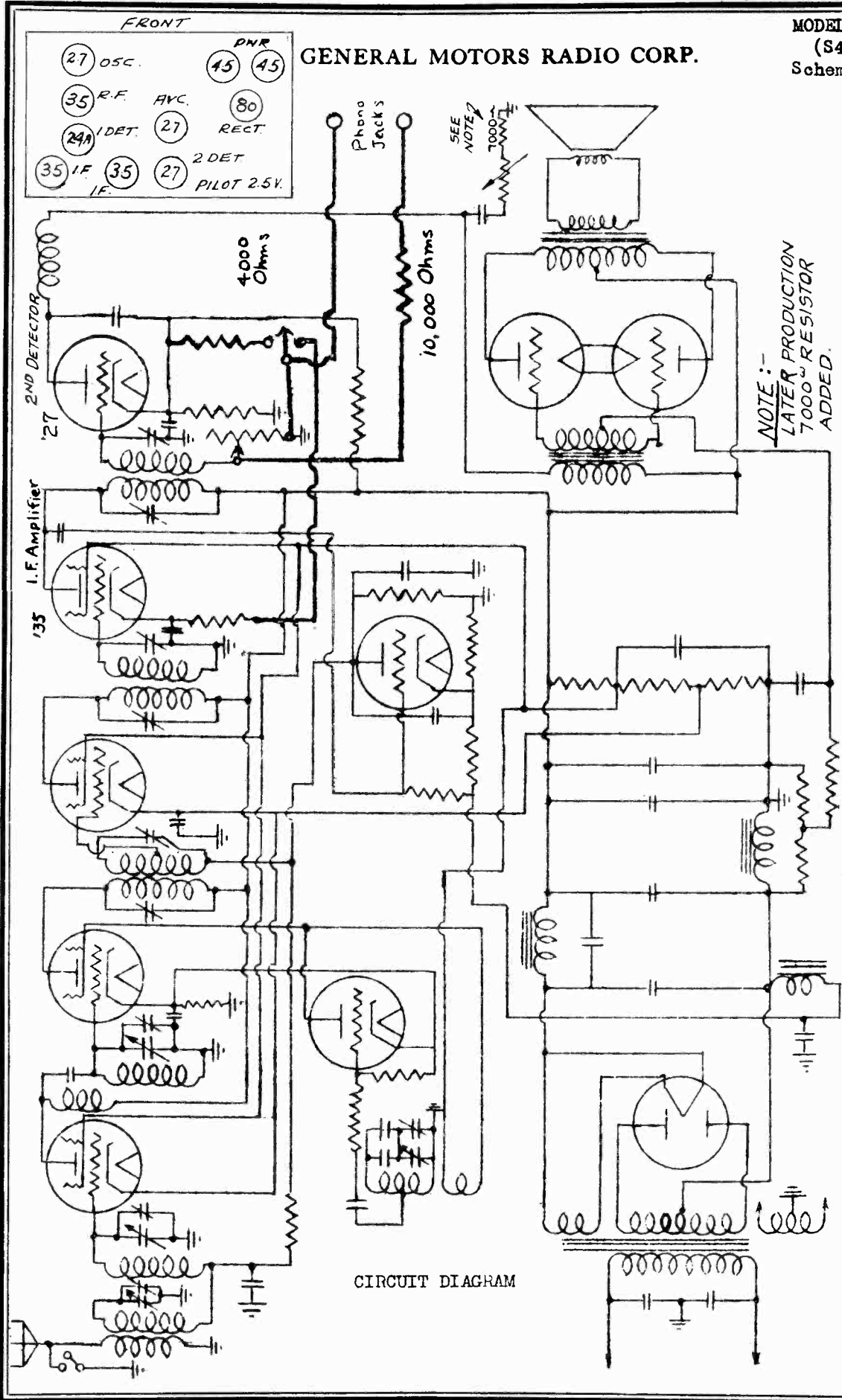

CIRCUIT DIAGRAM

SPECIAL PARTS LIST FOR S4A AND S4B

Name of Part	Part No.
Shaft, Switch Cable Drive	1204770
Resistor, 4,000 Ohms	1204108
Bracket, Phono Switch	1204763
Switch, Phono-Radio	1204552
Resistor, 10,000 Ohms	1201633
Cable, Switch Drive	1204764
Transformer, No. 3 I.F.	1202591
Insulator, Phono Jack	1200435
Jack, Phono	1200438
Pick-Up Head & Cable	1202609
Cover, Needle Cup	1204612

MODEL 292,293

Changes
 MODEL 253,254,255,
 256,257,258
 Changes

GENERAL MOTORS RADIO CORP.

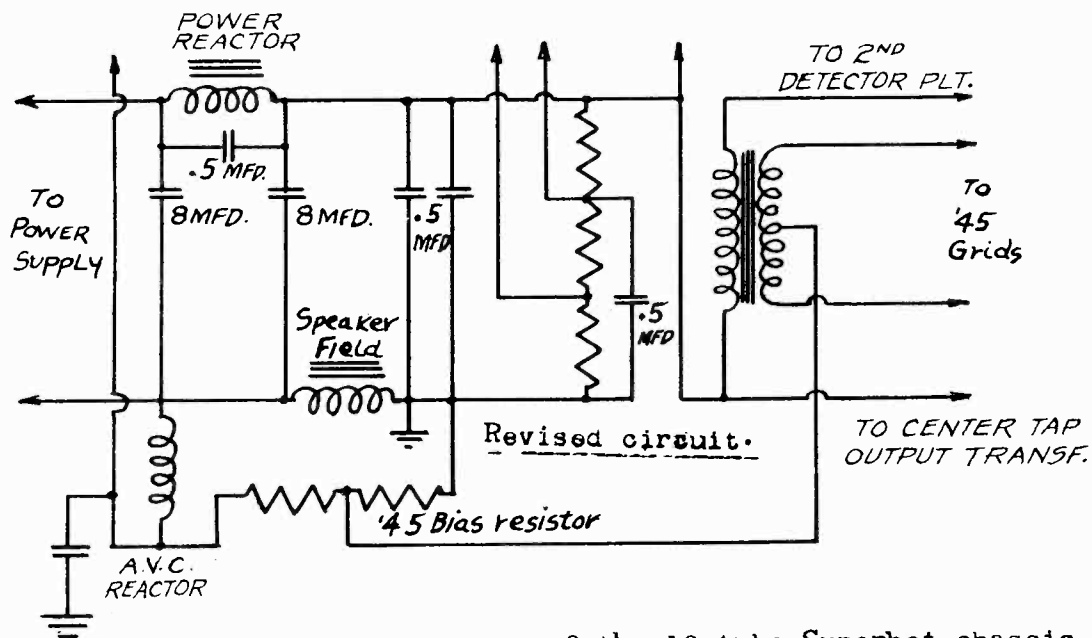

The grid return of the 10 tube Superhet chassis has been changed on chassis beginning with serial numbers approximately as follows:

Chassis model	Serial #	Note:For original circuit refer to:
S-3-A	3429	Rider Manuals
S-3-B	1069	Early 346-I
S-4-A	1296	Revised 2-11 & 2-12
S-4-B	1001	Radiotron 1101-1102

The change in the circuit also involves changes in parts numbers of two parts as follows:

	Part # below serial listed above	Part # above serial listed above.
245 bias resistor	1203535	1205259
Bypass cond.pack	1205971	1204162 or 1205971

Note if it should be necessary to replace the bypass cond.pack on models which use the original circuit, use part # 1205971.

if it should be necessary to replace bypass cond.pack on models which use the new circuit (shown above) with the tone control in the 2nd det.plate circuit, use part # 120597 by cutting off the red lead.

To replace bypass cond.pack on models having revised circuit, as above, with tone control in 45 plate circuit, use cond.pack part # 1204162.

The two bypass cond.packs can be distinguished by the number of leads, as follows:

- # 1204162 = 7 leads
- # 1205971 = 8 leads

The 245 bias resistors can be distinguished by their length, color and number of sections, as shown on the diagram here.

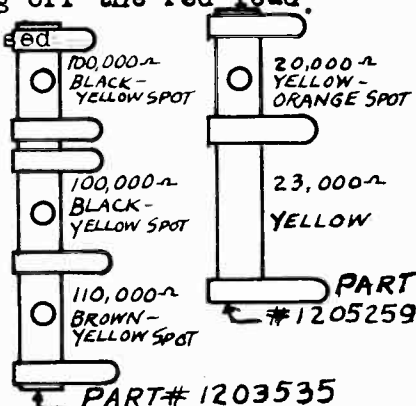

GILFILLAN BROS., INC

MODEL 6T,6C
Schematic,Alignment
MODEL 8T,8C,47,50
Alignment

Models 6-T and 6-C

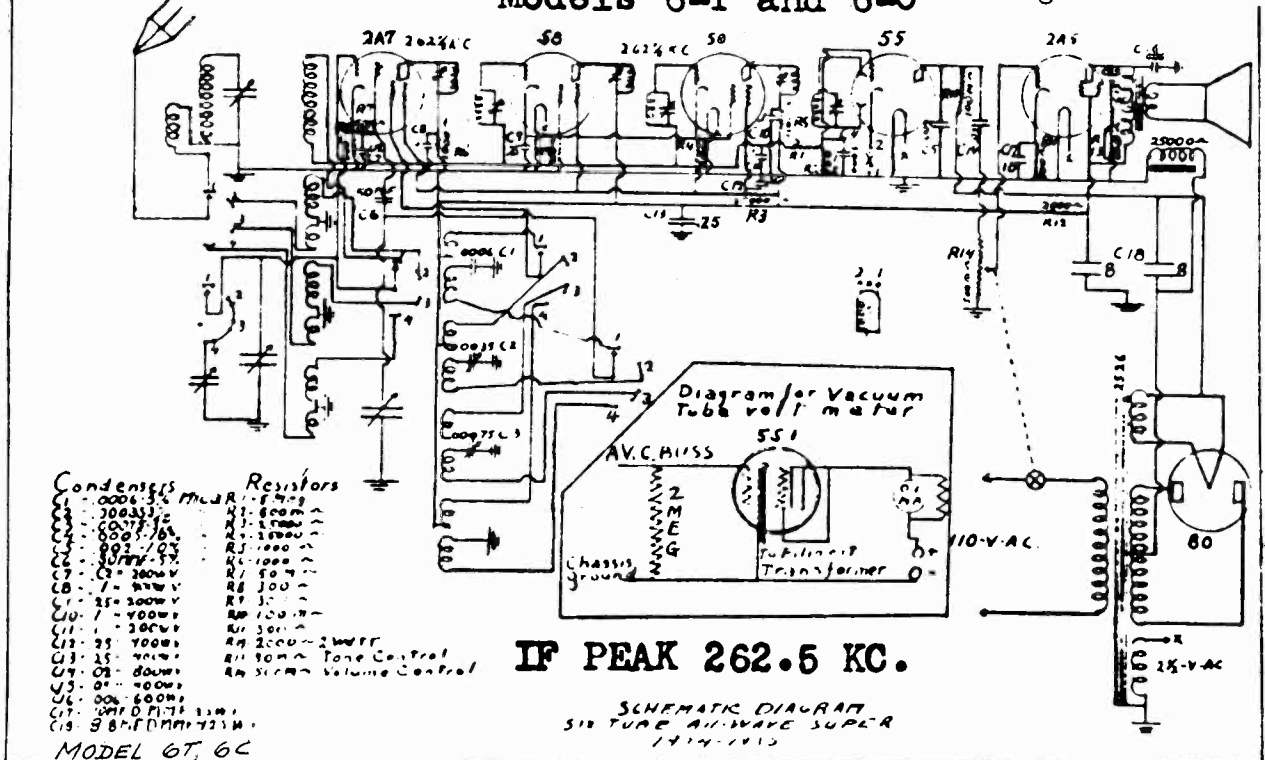

MODEL 6T, 6C

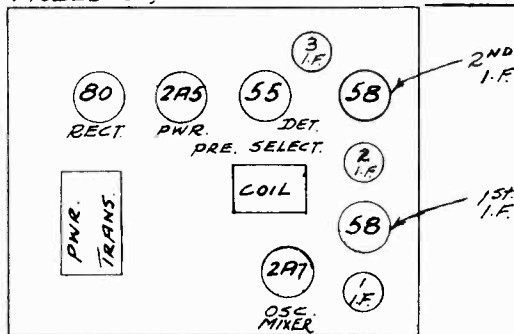

SERVICE DATA (SIX TUBE ALL-WAVE SUPER HETERODYNE 1934-1935)

SERVICE DATA EIGHT TUBE ALL-WAVE SUPER HETERODYNE 1934-1935)

All models have automatic volume control of the diode type, controlling the first detector as well as the high frequency amplifier tubes. This A.V.C. makes it impossible to service and rebalance without a meter of the type to be described. This meter will work on any make or type of A.V.C., provided care is used. It can not be damaged by improper connection of the leads.

PARTS REQUIRED FOR VACUUM TUBE VOLT METER

- O to 1 or O to 1.5 milliammeter.
- Bell ringing transformer with secondary of 6-10 volts.
- 5 prong socket.
- 551 tube.
- 2 megohm grid leak.
- 10 ohm rheostat.
- 45 volt B battery.
- Clips, Box, Cord, Hookup Wire.

USING VACUUM TUBE VOLT METER

The cathode clip is connected to the cathodes of the tubes controlled by the A.V.C. The buss clip is connected to the A.V.C. buss in front of the isolating resistor. Adjust rheostat shunt until meter shows full scale reading. All balancing is done with maximum peak indicated by the meter swing toward O. Sensitivity of various receivers can be checked by the swing of meter from a known station. Short Wave fading can be seen by tuning in the station with meter connected to set.

REBALANCING

Do not rebalance a set until you are sure it requires it. 99 per cent of the sets do not need it. We do not find one case in one hundred that really should be rebalanced.

INTERMEDIATES

Connect a 262½ K. C. oscillator to the first detector grid (No. 2-A 7 tube) leaving grid cap in place. Set dial at 1400 K.C. Hook up vacuum tube meter as described and carefully adjust 3 screws on top of intermediates for maximum gain (minimum reading of meter). Don't flat top any stages. Have all shields in place. Keep volume control at lowest level.

CONDENSER GANG

Set dial at 1400 K.C. when gang is at minimum position and tighten dial set screws. Tune in a station (or use an oscillator) to a known frequency signal around 1400 K.C. Carefully adjust oscillator section of gang until frequency is correct on dial.

If the intermediates are balanced on 262½ K.C., the dial will now track within 5 K.C. over the entire dial.

Adjust first detector section for maximum gain and follow by adjusting band pass trimmers.

Don't bend any condenser plates unless absolutely necessary.

MODEL 8C,8T,47,50

Schematic

GILFILLAN BROS., INC.

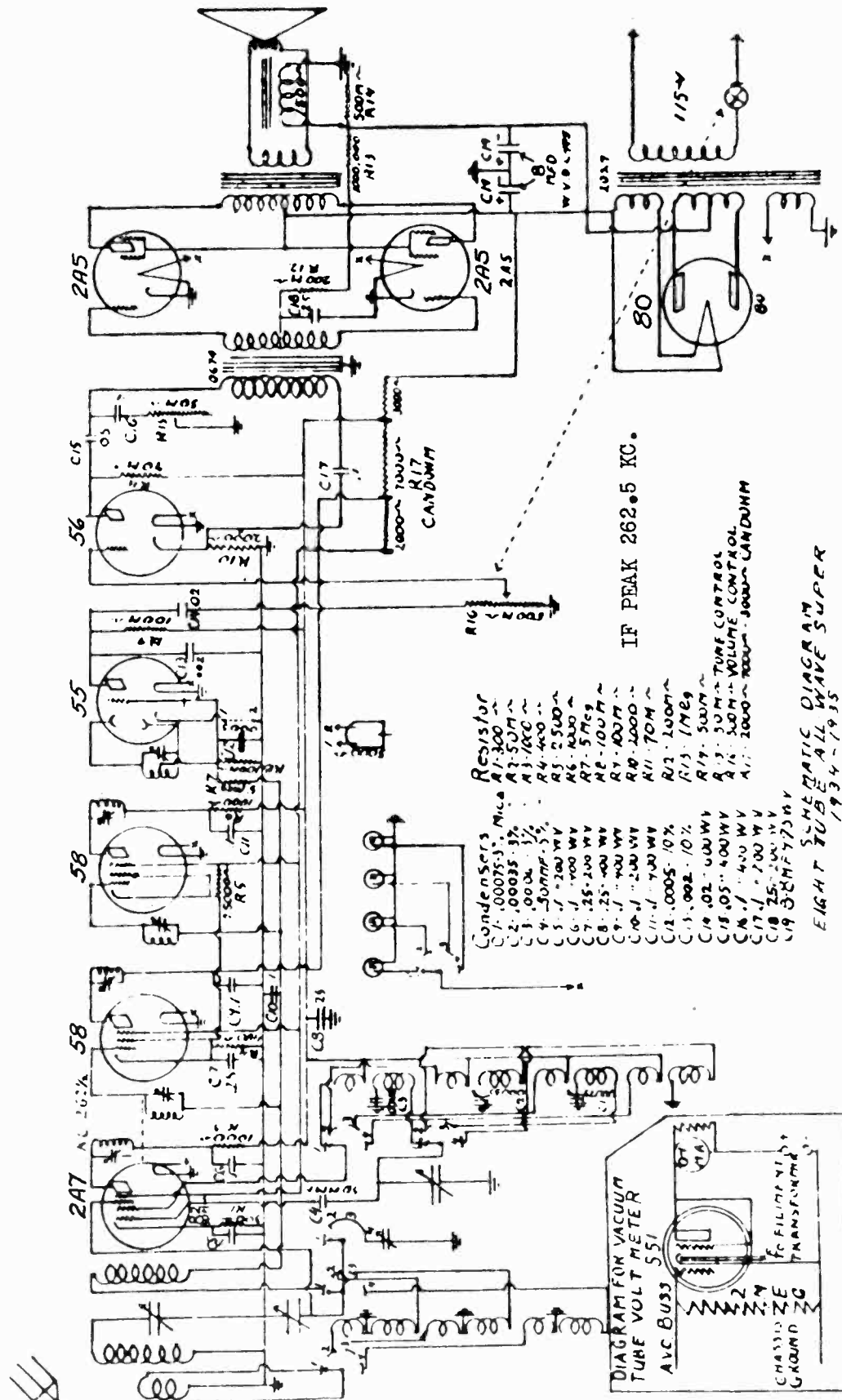

For Alignment,
See Index

GILFILLAN BROS., INC.

MODEL 4T, 30
Schematic, Socket
Alignment
MODEL 5C, 5T, 32, 35, 41
Schematic, Socket
Alignment

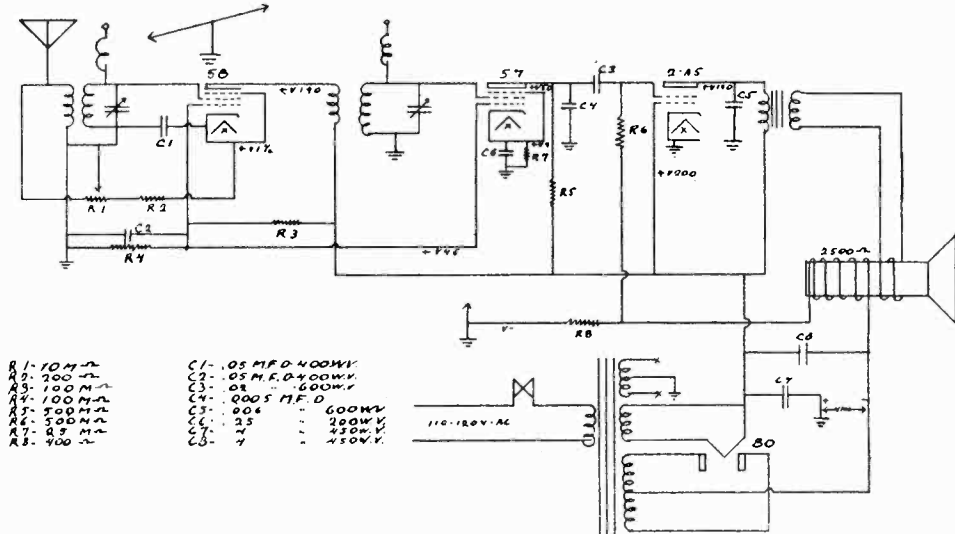

- | | |
|---------------------|-----------------------|
| R1 - 10M Ω | C1 - .05 MFD. 400MV |
| R2 - 200 Ω | C2 - .05 M.F. 2,400MV |
| R3 - 100M Ω | C3 - .01 - .600M.F. |
| R4 - 100M Ω | C4 - .0005 M.F. D |
| R5 - 200M Ω | C5 - .005 - 600MV |
| R6 - 500M Ω | C6 - .25 - 200V |
| R7 - .25 M Ω | C7 - .1 - 450V |
| R8 - 400 Ω | C8 - .1 - 450V |

4 Tube T.R.F.
1934-1935

Models 30 and 4-T

MODEL 4T, 30 T.R.F.

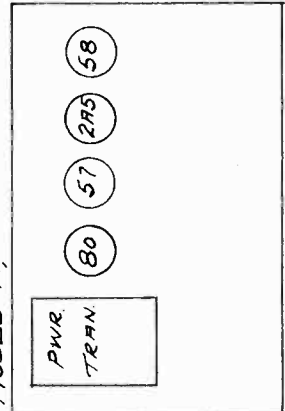

FRONT

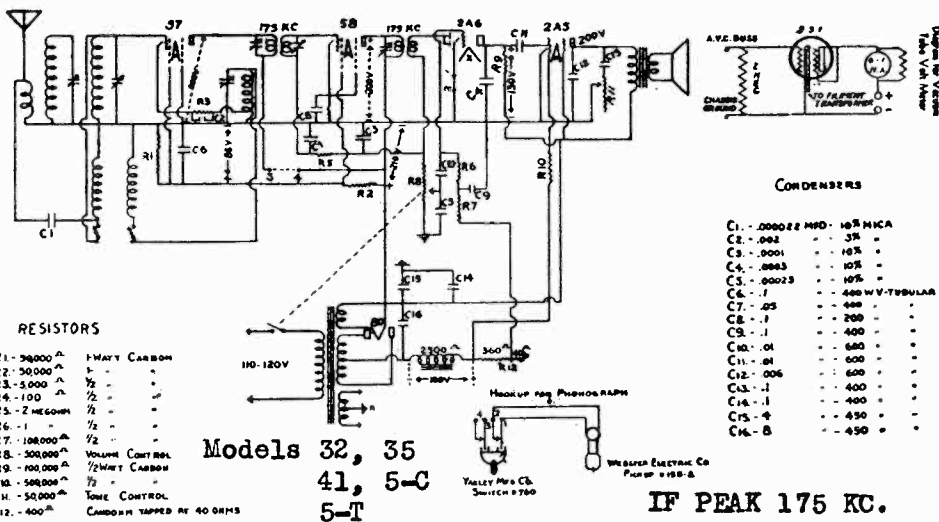

- RESISTORS
- | | |
|----------------------|--------------------------|
| R1 - 50,000 Ω | 1/2 WATT CARBON |
| R2 - 50,000 | 1/2 |
| R3 - 5,000 | 1/2 |
| R4 - 100 | 1/2 |
| R5 - 2 MEGOHM | 1/2 |
| R6 - 1 | 1/2 |
| R7 - 100,000 | 1/2 |
| R8 - 50,000 | VOLUME CONTROL |
| R9 - 100,000 | 1/2 WATT CARBON |
| R10 - 50,000 | 1/2 |
| R11 - 50,000 | TONE CONTROL |
| R12 - 400 | CARBON TAPPED BY 40 OHMS |

- CONDENSERS
- | |
|----------------------------|
| C1 - .00022 MFD - 16% NICA |
| C2 - .002 |
| C3 - .0001 |
| C4 - .0003 |
| C5 - .00023 |
| C6 - .1 |
| C7 - .05 |
| C8 - .1 |
| C9 - .1 |
| C10 - .01 |
| C11 - .01 |
| C12 - .006 |
| C13 - .1 |
| C14 - .1 |
| C15 - .4 |
| C16 - .8 |

Models 32, 35
41, 5-C
5-T

IF PEAK 175 KC.

MODEL 5T, 32, 35, 41

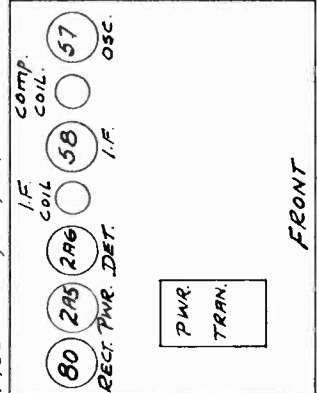

FRONT

SERVICE DATA, FIVE TUBE SUPER-HETERODYNE, 1934-1935

All models have automatic volume control of the diode type, controlling the first detector as well as the high frequency amplifier tubes. This A.V.C. makes it impossible to service and rebalance without a meter of the type to be described. This meter will work on any make or type of A.V.C., provided care is used. It can not be damaged by improper connection of the leads.

USING VACUUM TUBE VOLT METER

The cathode clip is connected to the cathodes of the tubes controlled by the A.V.C. The buss clip is connected to the A.V.C. buss in front of the isolating resistor. Adjust rheostat shunt until meter shows full scale reading.

All balancing is done with maximum peak indicated by the meter swing toward O. Sensitivity of various receivers can be checked by the swing of meter from a known station. Short Wave fading can be seen by tuning in the station with meter connected to set.

REBALANCING

Do not rebalance a set until you are sure it requires it. 99 per cent of the sets do not need it. We do not find one case in one hundred that really should be rebalanced.

INTERMEDIATES

Connect a 175 K.C. oscillator to the first detector grid (No. 57 tube) leaving grid cap in place. Set dial at 1400 K.C. Hook up vacuum tube volt meter as described and carefully adjust 3 screws on top of intermediates for maximum gain (minimum reading of meter). Don't flat top any stages. Have all shields in place. Keep volume control at lowest level.

CONDENSER GANG

Set dial at 1400 K.C. when gang is at minimum position and tighten dial set screws. Tune in a station (or use an oscillator) to a known frequency signal around 1400 K.C. Carefully adjust oscillator section of gang until frequency is correct on dial.

If the intermediates are balanced on 175 K.C., the dial will now track within 5 K.C. over the entire dial.

Adjust first detector section for maximum gain and follow by adjusting band pass trimmers.

Don't bend any condenser plates unless absolutely necessary.

MODEL 5X, 34, 55A, 55B
 Schematic, Socket
 MODEL 6C, 6T, 8C, 8T, 47, 50
 Socket Layout

GILFILLAN BROS., INC.

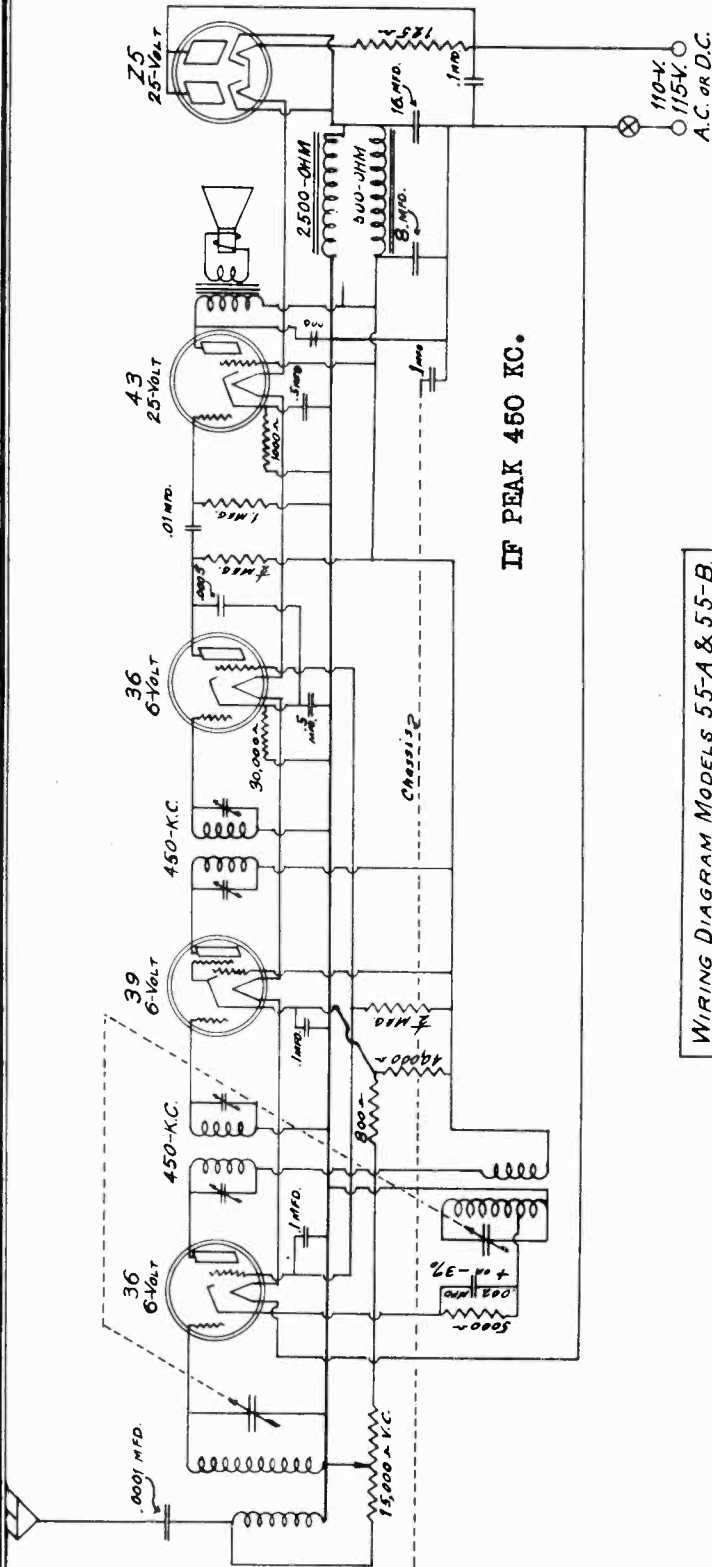

IF PEAK 450 KC.

WIRING DIAGRAM MODELS 55-A & 55-B
 GILFILLAN BROS. INC.
 LOS ANGELES, CALIF.

MODEL 5X, 34, 55A, 55B, AC-DC.

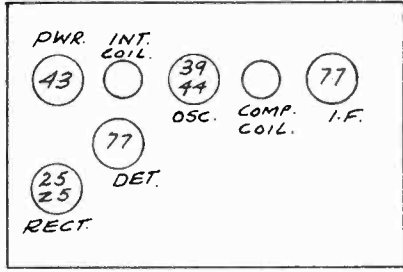

FRONT

MODEL 8T, 8C, 47, 50

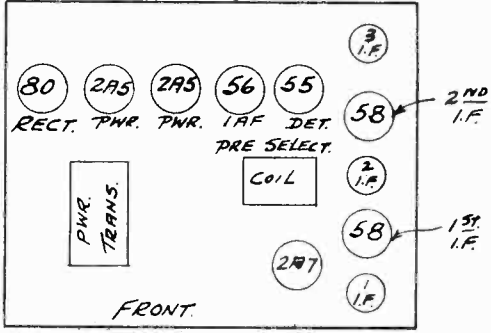

FRONT

3-26-33
 Designed by Chas Zingle
 Drawn by Bernard Smith

GRIGSBY - GRUNOW CO.

MODEL F-50
Schematic

FIG-154

DATE	1932
9-14-32	1
9-27-32	2
10-5-32	3

**SCHEMATIC DIAGRAM OF FEDERAL-AUTOMATIC VOLUME CONTROL
SUPERHETERODYNE MODEL F-50 SINGLE SPEAKER**

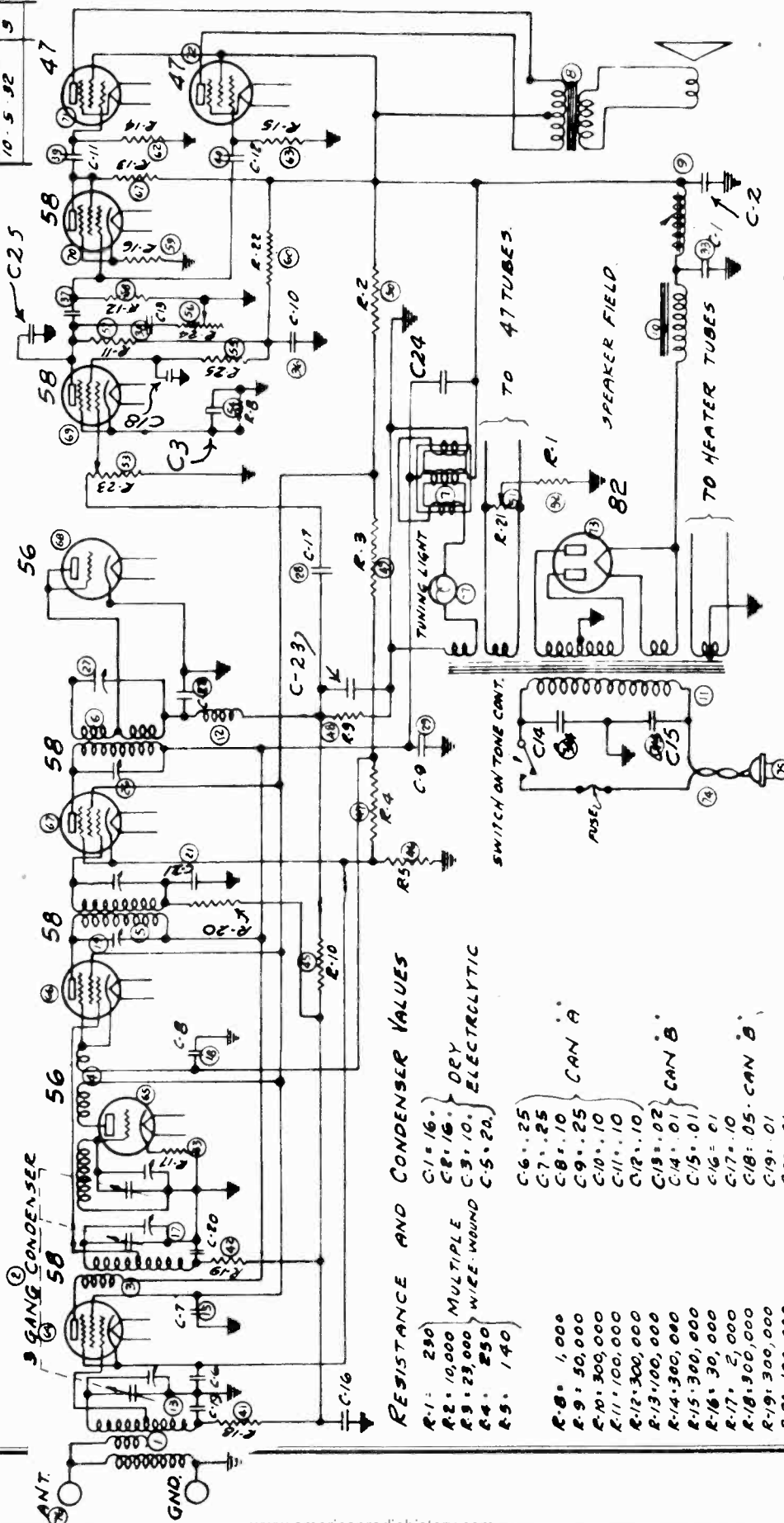

RESISTANCE AND CONDENSER VALUES

- R-1: 250
- R-2: 10,000 MULTIPLE
- R-3: 23,000
- R-4: 250
- R-5: 140
- C-1: 16
- C-2: 25
- C-3: 10
- C-4: 10
- C-5: 20
- C-6: 25
- C-7: 25
- C-8: 10
- C-9: 25
- C-10: 10
- C-11: 10
- C-12: 10
- C-13: 02
- C-14: 01
- C-15: 01
- C-16: 01
- C-17: 10
- C-18: 05
- C-19: 01
- C-20: 01
- C-21: 20 HUM CONTROL
- C-22: 0005 VOL CONTROL
- C-23: 0005 TONE CONTROL
- C-24: 25
- C-25: 0005

GRIGSBY-GRUNOW CO
CHICAGO, U.S.A

H.C.S. 9-14-32
A.D. Myring 9-15-32
E. H. ...

MODEL 118
Schematic

GRIGSBY - GRUNOW CO.

SCHMATIC DIAGRAM OF
MAJESTIC MODEL 118 AUTOMOBILE RECEIVER

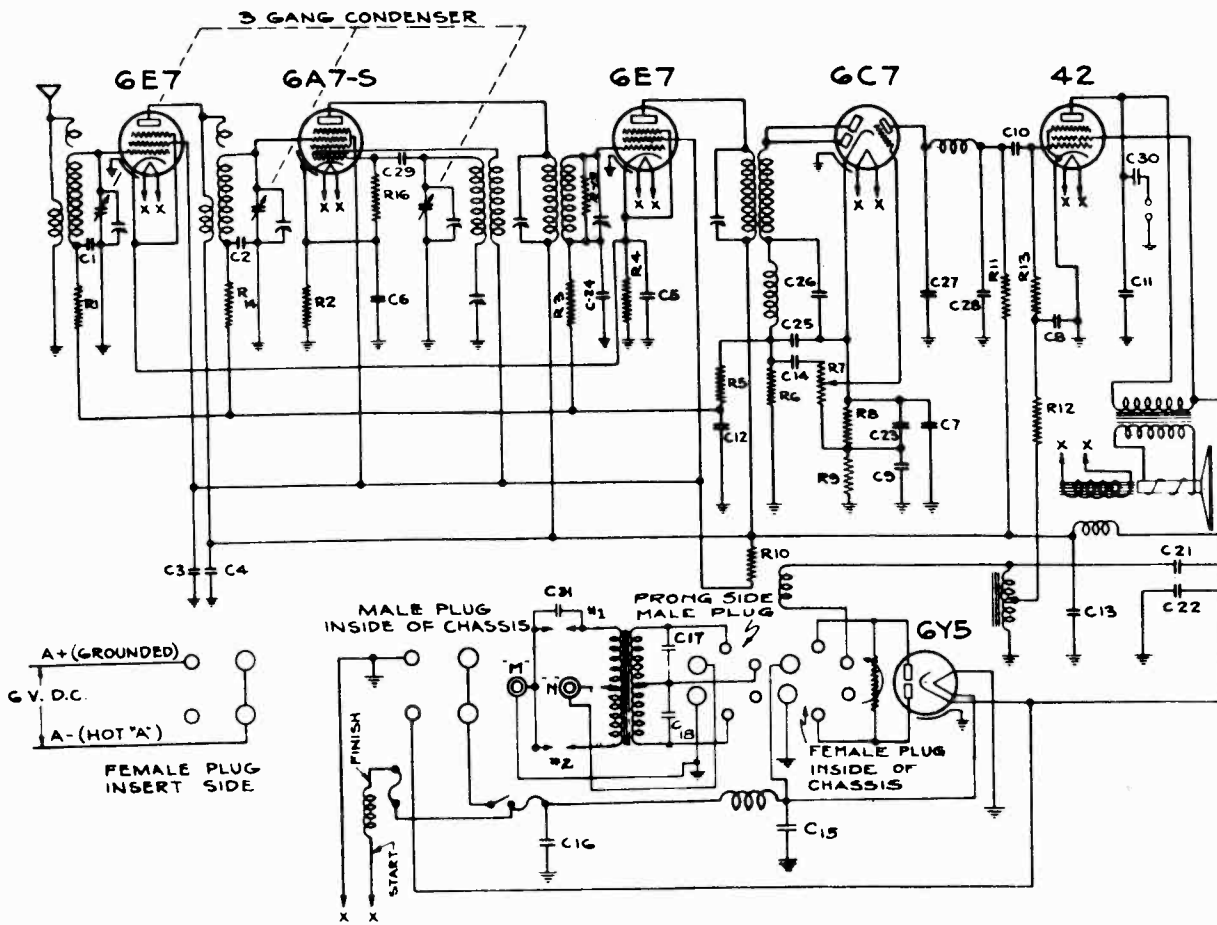

RESISTORS

- | | |
|-----------------|--------------------|
| R1—300,000 | R11—200,000 |
| R2—300 | R12—250,000 |
| R3—300,000 | R13—250,000 |
| R4—160 | R14—300,000 |
| R5—300,000 | R15—510,000 GLOBAR |
| R6—100,000 | R16—50,000 |
| R7—200,000 V.C. | R19—1,000,000 |
| R7B—2,500 | |
| R7C—5,000 | |
| R10—15,000 | |

CONDENSERS

- | | | |
|----------|-----------|------------|
| C1—.03 | } R.F. #1 | C16—.5 |
| C2—.03 | | C17—.008 |
| C3—.25 | } R.F. #2 | C18—.008 |
| C4—.25 | | |
| C5—.25 | } A.F. #1 | C21—8.0 |
| C6—.1 | | C22—8.0 |
| C7—.25 | } A.F. #2 | C23—10.0 |
| C8—.25 | | C24—.01 |
| C9—.25 | } A.F. #2 | C25—.0005 |
| C10—.03 | | C26—.0005 |
| C11—.005 | | C27—.0005 |
| C12—.03 | | C28—.0005 |
| C13—.25 | | C29—.00025 |
| C14—.03 | | C30—.1 |
| C15—.5 | | C31—20.0 |

M - TERMINAL CONNECTED TO ARMATURE

GRIGSBY - GRUNOW CO.

SCHEMATIC DIAGRAM OF MAJESTIC MODEL-570 RECEIVER

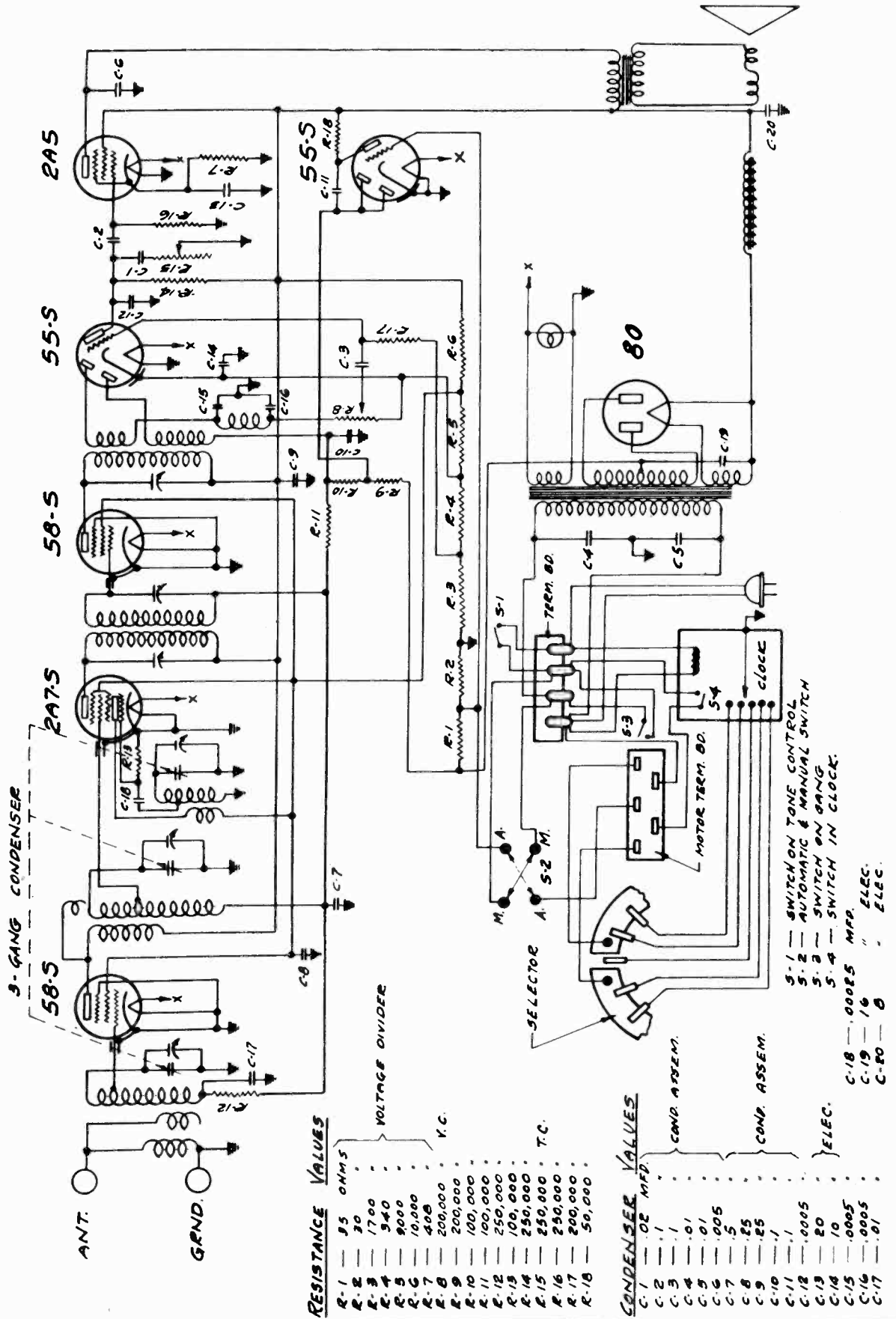

RESISTANCE VALUES

R-1	75	OHMS
R-2	30	"
R-3	1700	"
R-4	540	"
R-5	9000	"
R-6	10,000	"
R-7	400	"
R-8	200,000	"
R-9	200,000	"
R-10	100,000	"
R-11	100,000	"
R-12	250,000	"
R-13	100,000	"
R-14	250,000	"
R-15	250,000	"
R-16	200,000	"
R-17	200,000	"
R-18	50,000	"

VOLTAGE DIVIDER

V.C.

T.C.

CONDENSER VALUES

C-1	.02	MFD.
C-2	.1	"
C-3	.1	"
C-4	.01	"
C-5	.01	"
C-6	.005	"
C-7	.5	"
C-8	.25	"
C-9	.25	"
C-10	.1	"
C-11	.1	"
C-12	.0005	"
C-13	.20	"
C-14	.10	"
C-15	.0005	"
C-16	.0005	"
C-17	.01	"

CAND. ASSEM.

COND. ASSEM.

ELEC.

- S-1 — SWITCH ON TONE CONTROL
- S-2 — AUTOMATIC & MANUAL SWITCH
- S-3 — SWITCH ON GANG
- S-4 — SWITCH IN CLOCK.
- C-18 — .00025 MFD. ELEC.
- C-19 — .10 " ELEC.
- C-20 — 0 " ELEC.

MODEL 600 AC-DC
Schematic

GRIGSBY - GRUNOW CO.

SCHEMATIC DIAGRAM OF MAJESTIC MODEL 600 AC-DC RECEIVER

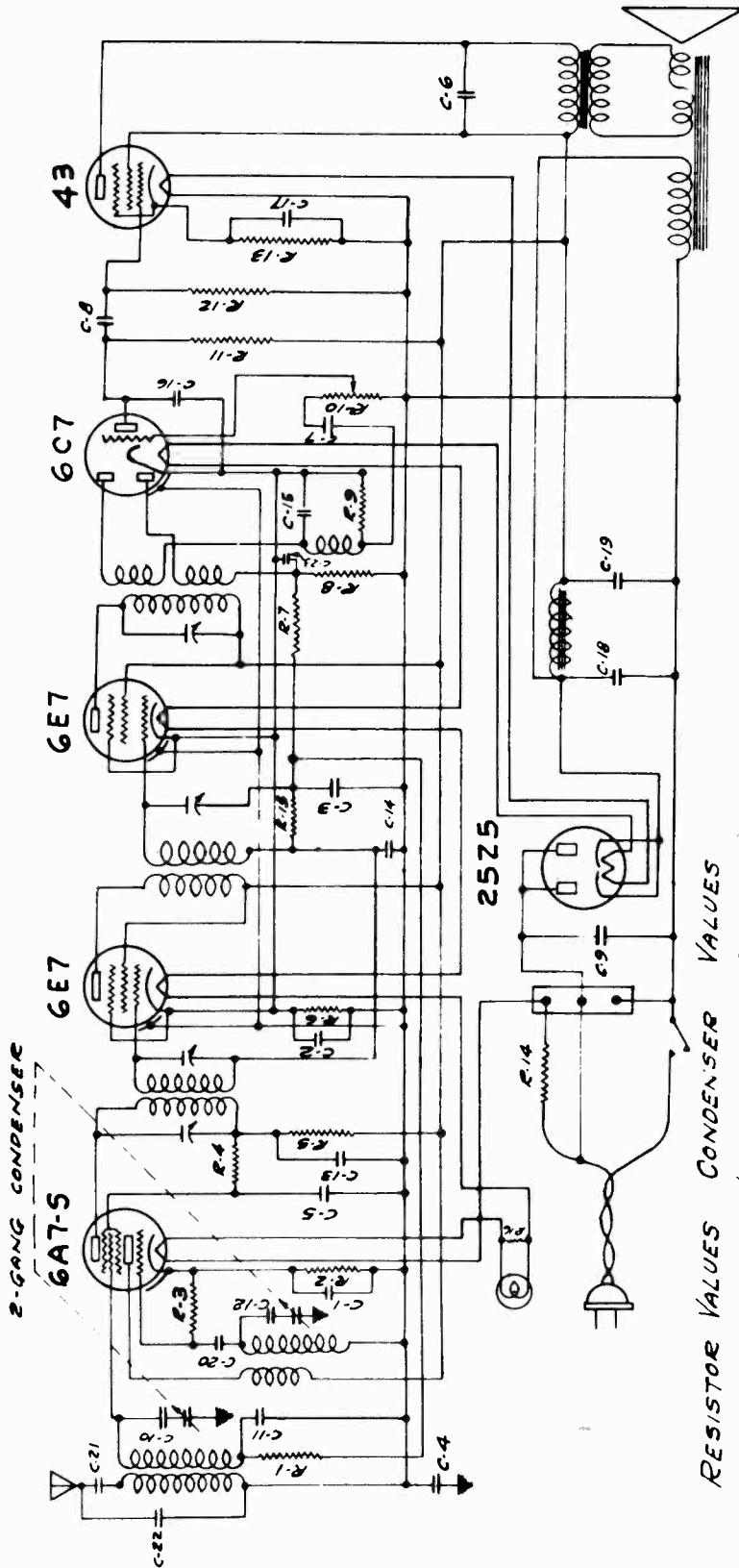

RESISTOR VALUES CONDENSER VALUES

RESISTOR	VALUES	CONDENSER	VALUES
R-1	300,000	C-1	.25 MFD.
R-2	400	C-2	.25
R-3	50,000	C-3	.25
R-4	6,000	C-4	.5
R-5	1,000	C-5	.1
R-6	140	C-6	.03
R-7	100,000	C-7	.03
R-8	200,000	C-8	.1
R-9	200,000	C-9	.1
R-10	200,000 V.C.	C-10	.01
R-11	100,000	C-11	.01
R-12	500,000	C-12	.01
R-13	700	C-13	.03
R-14	100	C-14	.01
R-15	300,000	C-15	.0005
R-16	34.5	C-16	.0005
		C-17	10. ELECTROLYTIC

C-18 — 16. MFD. ELECTROLYTIC
 C-19 — .01
 C-20 — .0005 MFD.
 C-21 — .001
 C-22 — .0005
 C-23 — .0005

BY PASS ASSEM.
 BY PASS ASSEM.

GULBRANSEN CO.

MODEL 872
Schematic, Changes
Socket Layout

Change in Later Models

In the first models of this chassis, resistors R-1 and R-3 were carbon resistors of the values as shown in Fig. 1. Resistors R-12 and R-14, were in one vitreous enamel unit. The voltages for the sets with these resistors are shown in the voltage chart on Page 4 at the left.

In later models the four above mentioned resistors were replaced by one armored wire wound resistor unit. New values are used as follows

Code	Resistance
R-12	220 ohms
R-14	40 ohms
R-1	9,540 ohms
R-3	10,650 ohms

The voltages for the sets with the four-section wire wound resistor are shown in the second voltage chart on Page 4 at the right.

Twenty-five Cycle Receivers

The twenty-five cycle receiver differs from the sixty cycle receiver only in the fact that a different power transformer and an additional filter condenser are used. Also, a slight change is made in the power unit wiring. In the twenty-five cycle set, condenser C-17 the dry electrolytic unit is put in parallel with condenser C-14. An 8.0 mfd wet electrolytic condenser is put in place of condenser C-17.

The twenty-five cycle chassis can be operated satisfactorily from a sixty cycle power supply. However, the reverse is not true that is the sixty cycle chassis cannot be operated from a twenty-five cycle power supply.

A 110-220 volt 40-60 cycle power transformer is also available for this model.

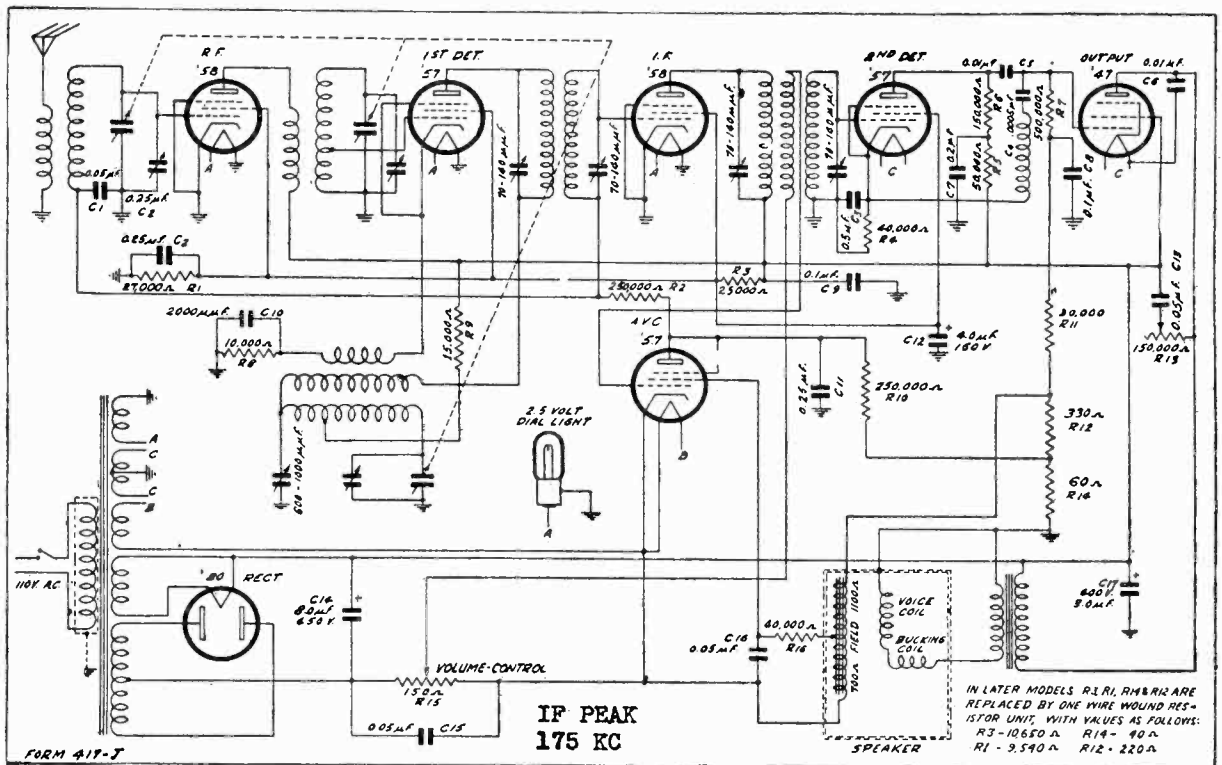
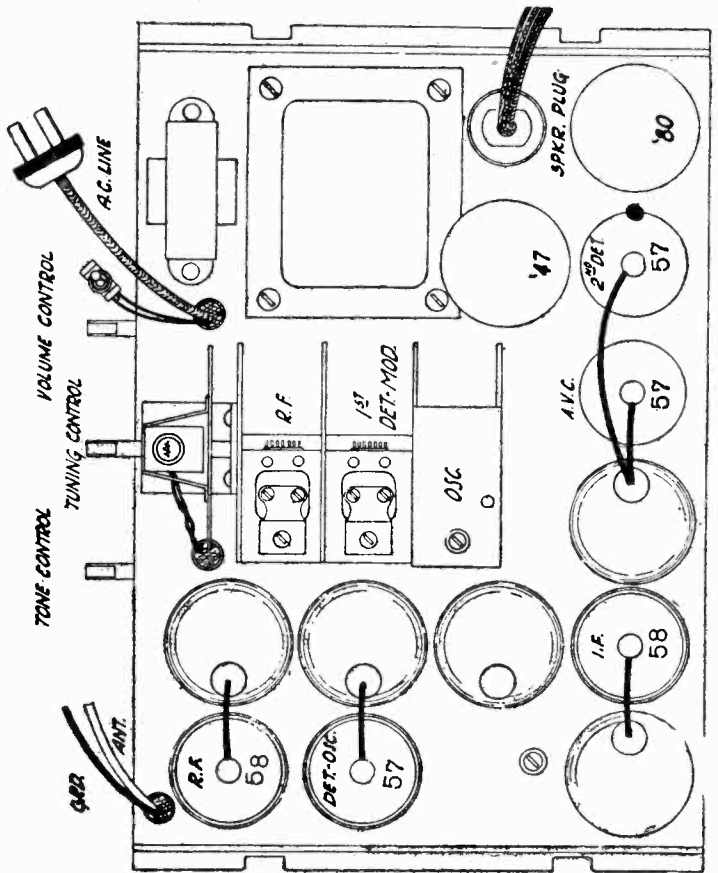

MODEL 872

Alignment, Voltage
Parts List

GULBRANSEN CO.

Condenser Alignment

Misalignment or mistracking of condensers generally manifests itself in broad tuning and lack of volume at portions or all of the broadcast band. The receivers are all properly aligned at the factory with precision instruments and realignment should not be attempted unless all other possible causes of the faulty operation have first been investigated and unless the service technician has the proper equipment. A signal generator that will provide an accurately calibrated signal of 175 K.C. and accurately calibrated signals over the broadcast band, and an output indicating meter are necessary. The procedure is as follows:

Set the signal generator for 175 K.C. Connect the signal lead from the signal generator to the grid of the 1st detector tube through a .05 mfd. condenser. Turn the tuning condenser rotor until the plates are completely out. The ground lead from the signal generator goes to the ground lead of the receiver. Then adjust the four intermediate frequency condensers for maximum output. The adjusting

screws for these condensers are reached from the bottom of the chassis.

Next set the signal generator for a signal of exactly 1400 K.C. The antenna lead from the signal generator, in this instance, connected to the antenna lead of the receiver. Set the dial pointer on the 1400 K.C. mark on the dial scale and adjust the three trimmer condensers on the gang tuning condenser for maximum output, adjusting the oscillator trimmer first.

Next set the signal generator for a signal of 600 K.C. and adjust the oscillator 600 K.C. trimmer. The adjusting screw for this condenser is reached from the top of the chassis and is between the I.F. and oscillator coil cans.

A non-metallic screwdriver is necessary for this adjustment. Turn the tuning condenser rotor until maximum output is obtained. Then turn the rotor slowly back and forth over this setting, at the same time adjusting the 600 K.C. trimmer screw until the highest output is obtained.

Then set the signal generator again for a signal of 1400 K.C. and check the adjustment of the tuning condenser trimmers at this frequency for maximum output.

Voltages at Sockets

LINE VOLTAGE 115—ANTENNA LEAD SHORTED TO GROUND—VOLUME CONTROL AT MAXIMUM

Type of Tube	Function	Across Filament or Heater	For early Models with 2-section vitreous enamel resistor.				For later Models with 4-section armoured wire-wound resistor.			
			Plate to Cathode	Screen to Cathode	Grid to Cathode	Normal Plate M. A.	Plate to Cathode	Screen to Cathode	Grid to Cathode	Normal Plate M. A.
'58	R.F.	2.4	282	107	4 ⁽¹⁾	8.	258	106	2.8 ⁽¹⁾	8.0
'57	1st Det.	2.4	270	100	5	.4	250	103	5	.4
'58	I.F. ⁽²⁾	2.4	282	107	4 ⁽¹⁾	8.	258	106	2.8 ⁽¹⁾	8.0
'57	A.V.C.	2.4	90	40	9.5	0	103.	45	10	0
'57	2nd Det.	2.4	207	98	6	.15	190	101	.6	.15
'47	Audio	2.4	262	280	24 ⁽³⁾	31	242	260	17 ⁽³⁾	30
'80	Rect.	4.8				30 per plate				34 per plate

(1) Read Across R-14.

(2) If I.F. readings are made with a cord and plug, ground the control grid through a condenser to prevent oscillation.

(3) Read Across R12 and R14.

REPAIR PARTS LIST FOR 7 TUBE SUPERHETERODYNE RECEIVER

When ordering parts, the part number and the serial number of chassis must be given. If there is a spot of paint on the chassis be sure to give this color. If this information is not available return the old part to insure getting the correct part.

Part No.	Name	List Price
P-1677	No. 57 Tube Socket	\$.15
P-1678	No. 58 Tube Socket	.15
P-1468	No. 47 Tube Socket	.15
P-1474	No. 80 Tube Socket	.15
P-1479	Speaker Socket	.15
P-40420	Aluminum Tube Shield	.20
P-40425	Tube Shield Base	.10
P-40411	Aluminum Coil Shield—R.F. Coils	.20
P-1476	Three-Lug Insulated Terminal Strip	.10
P-1513	Eleven-Lug Insulated Terminal Strip	.15
P-1054	"On-Off" Switch	.80
P-20529	Drive Shaft	.10
P-10224	Rubber Drive Pinion	.10
P-30374	Brass Bushing for Rubber Pinion	.10
P-10191	Rubber Cushions for Channel Brackets	.10
P-1273	Pilot Lamp 2.5 Volt	.25
P-5062	Antenna R.F. Transformer Assembly	.80
P-5057	Interstage R.F. Transformer Assembly	.80
P-5058	Oscillator Coil Assembly	.95
P-5059	1st I.F. Transformer Assembly, complete with can	2.25
P-5060	2nd I.F. Transformer Assembly, complete with can	2.50
P-50541	Output Transformer Assembly	1.75
P-50542	Power Transformer, 60 cycle, 110 volt	5.25
P-50543	Power Transformer, 25 cycle, 110 volt	8.50
P-50545	Power Transformer, 40-60 cycle, 110 volt	8.00
P-1497	Pilot Light Bracket and Drive Gear Assembly	.45
P-1383-C	Drive Bracket and Bearing	.30
P-1684	Celluloid Dial Strip	.20

CONDENSERS

Part No.	Code	Capacity	Voltage	Type	List Price
P-80862-C	C-1	.05 mfd.	200 V.	Tubular	\$.30
P-80888-A	C-2	.25 mfd.	200 V.	Tubular	.40

P-80886-C	{ C-3 .5 mfd. 200 V. }	Block	1.60
	{ C-7 .2 mfd. 400 V. }		
	{ C-11 .25 mfd. 200 V. }		
P-80867	C-4 .0005 mfd. 600 V.	Molded	.25
P-80872-II	C-5 .01 mfd. 600 V.	Tubular	.25
P-80872-B	C-6 .01 mfd. 600 V.	Tubular	.25
P-80864-D	C-8 .1 mfd. 200 V.	Tubular	.25
P-80887-B	C-9 .1 mfd. 400 V.	Tubular	.40
P-80914	C-10 .002 mfd. 600 V.	Tubular	.20
P-80891-B	C-12 4.0 mfd. 150 V.	Electrolytic	.85
P-80890-B	C-13 .05 mfd. 400 V.	Tubular	.20
P-80894-B	{ C-14 8.0 mfd. 450 V. }	Electro-lytic Block	2.85
	{ C-17 8.0 mfd. 450 V. }		
P-80862-C	C-15 .05 mfd. 200 V.	Tubular	.30
P-80862-C	C-16 .05 mfd. 200 V.	Tubular	.30
P-80849	8.0 mfd. 450 V.	Wet Electrolytic (25 Cycle only)	2.20
P-1385-B	600 K.C. Trimmer Condenser		.75
P-80882	Three-Gang Condenser		5.70

RESISTORS

Part No.	Code	Resistance	Wattage	Type	List Price
*P-91003	R-1	27,000 ohms	.5 Watts	Carbon	\$.25
P-90954	R-2	250,000 ohms	.2 Watts	Carbon	.25
*P-91002	R-3	25,000 ohms	1.0 Watts	Carbon	.25
P-90916	R-4	40,000 ohms	.2 Watts	Carbon	.25
P-90941	R-5	50,000 ohms	.2 Watts	Carbon	.25
P-90963	R-6	150,000 ohms	.2 Watts	Carbon	.25
P-90929	R-7	500,000 ohms	.2 Watts	Carbon	.25
P-90930	R-8	10,000 ohms	.2 Watts	Carbon	.20
P-90905	R-9	15,000 ohms	.2 Watts	Carbon	.25
P-90954	R-10	250,000 ohms	.2 Watts	Carbon	.25
P-90956	R-11	30,000 ohms	.2 Watts	Carbon	.25
	{ R-12 330 ohms }				
*P-91040	{ R-14 60 ohms }			Vitreous Enamel	.50
P-90993	R-13	150,000 ohms		Tone Control	.90
P-91041	R-15	150 ohms		Volume Control	.80
P-90916	R-16	40,000 ohms	.2 Watts	Carbon	.25
†P-91048	{ R12 220 ohm 1.0 Watts }			Armored Wire-wound Resistor	1.05
	{ R14 40 ohm .2 Watts }				
	{ R1 9540 ohm 1.0 Watts }				
	{ R3 10650 ohm 2.5 Watts }				

* Used in early models—in later models these resistors are replaced by resistor P-91048.

† See above.

HALSON RADIO CORP.

MODEL 410
Schematic, Socket
Parts List

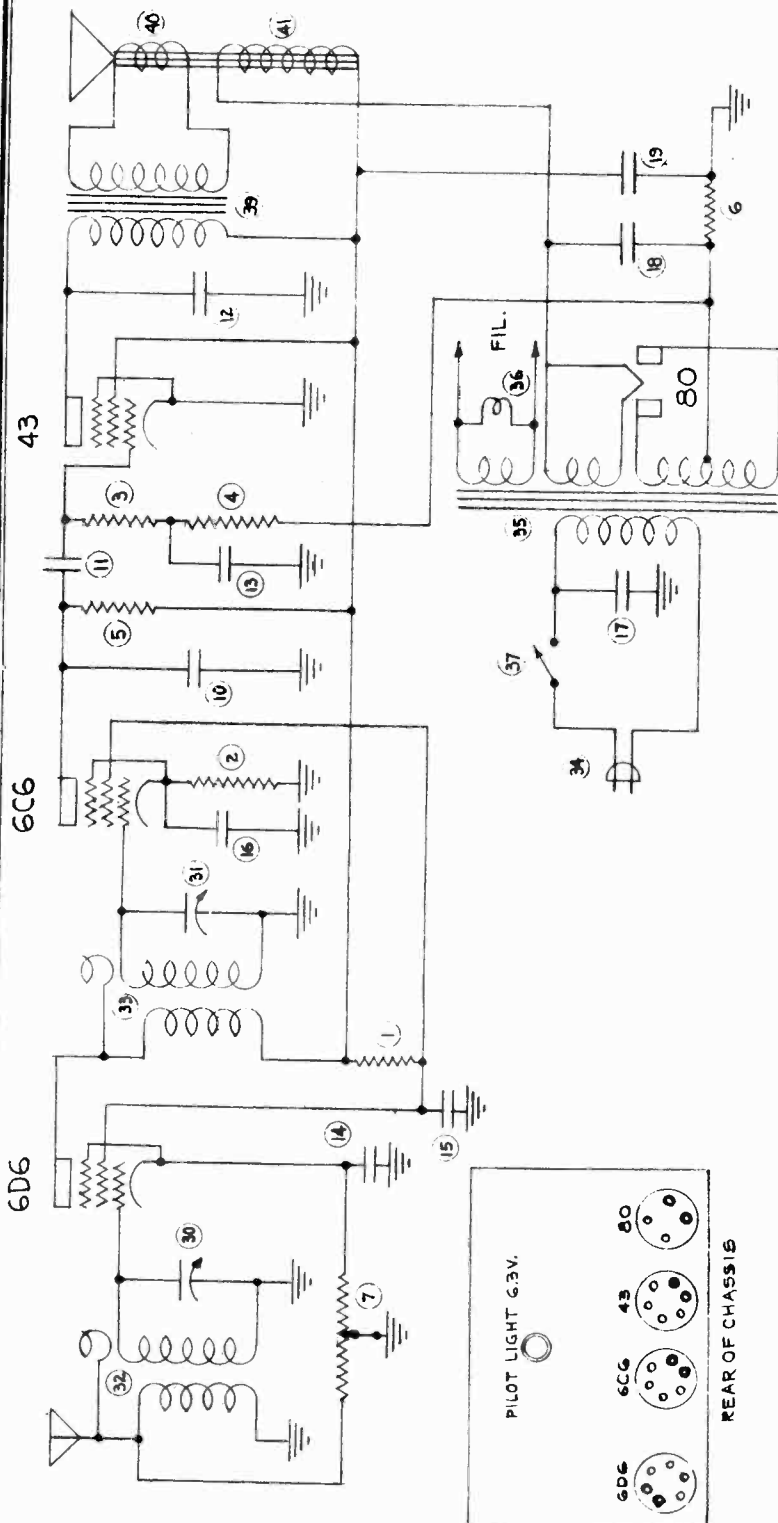

1	1158	RESISTOR	110,000 ^Ω	1 WATT	30	1285	VARIABLE COND.	370 M.M.F.	39	1293	OUTPUT TRANS.	7000 ^Ω
2	1160	"	51,000 ^Ω	1/4 "	31	"	"	"	"	40	SPARK VOICE COIL	
3	1165	"	260,000 ^Ω	"	32	1286	ANTENNA COIL			41	ASSY. (FIELD COIL	2000 ^Ω
4	"	"	"	"	33	1288	R.F. COIL					
5	1029	"	"	1 "	34	1115	LINE CORD & PLUG					
6	1292	"	400 ^Ω	1 "	35	1194	POWER TRANSFORMER					
7	1289	VOLUME CONTROL	25,000 ^Ω		36	1086	PILOT LIGHT	6.3 V.				
10	1098	CONDENSER	510 M.M.E. MICA	19	37	---	LINE SWITCH ON NO.7					

CIRCUIT DIAGRAM MODEL 410

DRAWN BY	CHECKED BY	APPROVED BY
E.A.W.	J.B.	J.B.

HALSON RADIO MFG. CORP. N.Y.C.

HALSON NUMBER 410

ALIGN TRIMMERS AT 1400 KC.

MODEL 520
Schematic, Socket
Alignment

HALSON RADIO CORP.

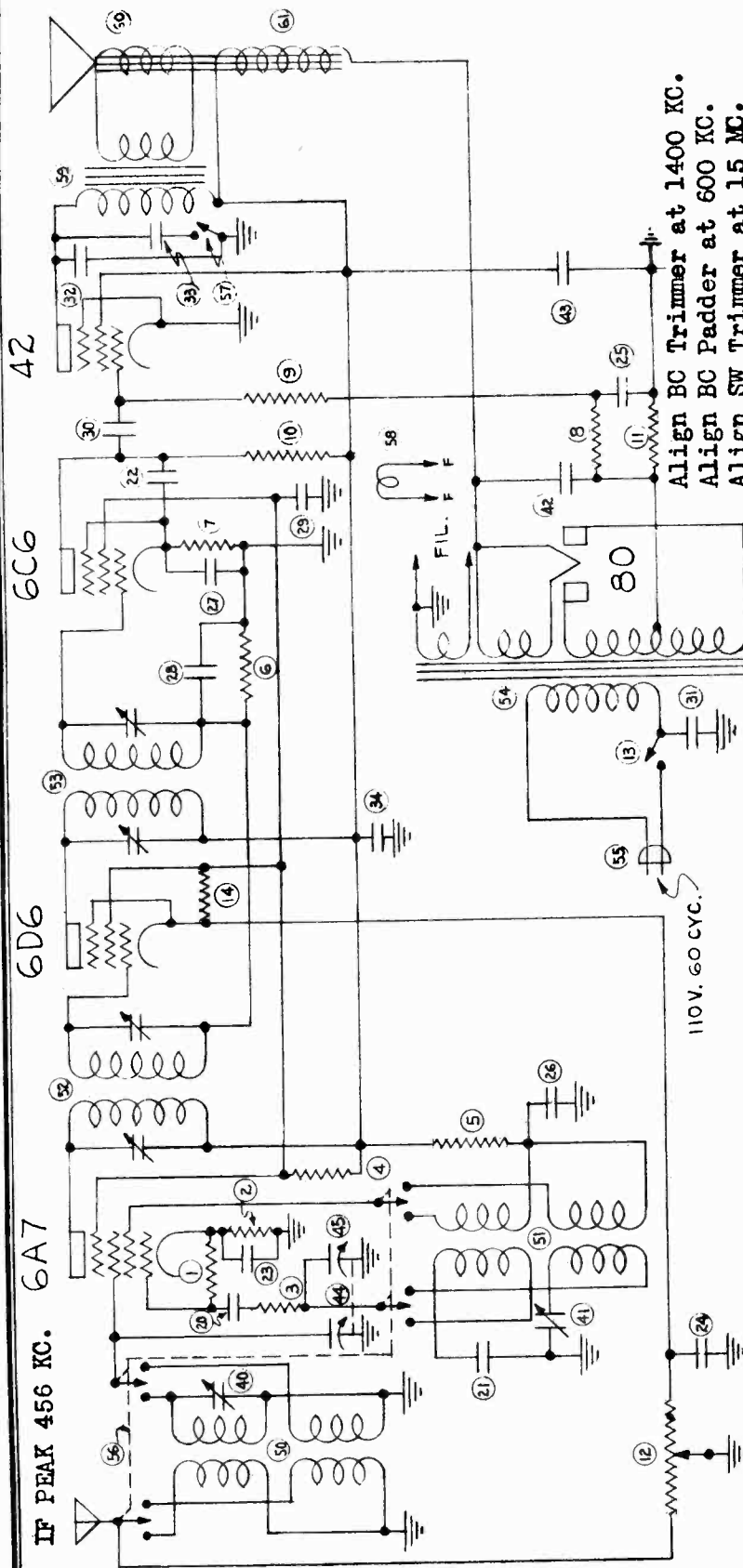

Align BC Trimmer at 1400 KC.
Align BC Padder at 600 KC.
Align SW Trimmer at 15 MC.

ITEM	PART NO.	NAME	VALUE	DESCRIPTION
1	1160	RESISTOR	51,000Ω 1/4 WATT	
2	1031	"	310Ω "	
3	1218	"	210Ω "	
4	1164	"	21,000Ω 1 "	
5	"	"	"	
6	1030	"	510,000Ω 1/4 "	
7	1160	"	51,000Ω "	
8	1165	"	260,000Ω "	
9	"	"	"	
10	1029	"	(WIRE) 310Ω "	
11	1273	"	VOLUME CONT. 25,000Ω Q	
12	1209	"	LINE SWITCH	
13	1245	"	RESISTOR 51,000Ω 1/2 WATT	
14	1245	"	RESISTOR 51,000Ω 1/2 WATT	
20	1099	CONDENSER	260 M.M.F. MICA	
21	1096	"	2500 "	
22	1098	"	510 "	
23	1040	"	.05 M.F. 200 V.	
24	"	"	"	
25	"	"	"	
26	1103	"	.25 "	
27	"	"	.1 "	
28	1036	"	.02 "	
29	"	"	400 V.	
30	1102	"	"	
31	"	"	.01 "	
32	1101	"	.05 "	
33	1275	"	.05 "	
34	"	"	"	
40	1107	ANT. TRIMMER COND.	5-50 M.M.F.	
41	1104	PADDING COND.	250-400 "	
42	1194	ELECTROLYTIC COND.	8 M.F. 450 V.	
43	"	"	"	
44	"	"	VARIABLE COND. 370 M.M.F.	
45	1206	"	"	
50	1211	ANTENNA COIL	"	
51	1212	OSCILLATOR COIL	"	
52	1213	I.F. TRANS.	456 K.C.	
53	"	"	"	
54	1112	POWER TRANS.	110 V. 60 V.	
55	1220	LINE CORD & PLUG	"	
56	1210	WAVE CHANGE SWITCH	"	
57	1203	ANT. TRIMMER COND.	5-50 M.M.F.	
58	1086	PILOT LIGHT	6.3 V.	
59	1221	OUTPUT TRANS.	7000Ω	
60	5PKR.	VOICE COIL	4 W	
61	"	ASSY.	FIELD COIL 1670Ω (HOT)	

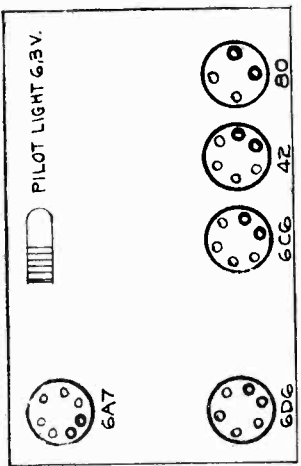

CIRCUIT DIAGRAM			MODEL 520		
DRAWN BY	CHECKED BY	APPROVED BY			
E. P. W. 6-28-34	Andy	[Signature]			
HALSON RADIO MFG. CORP. N.Y.C. N.Y. U.S.A.					

REVISIONS		
DATE	BY	REVISION
6-10-34	WAS	Added
"	"	"
"	"	"

HALSON RADIO CORP.

MODEL 530
Schematic, Socket
Alignment

IF PEAK 456 KC.
Align BC Trimmer at 1400 KC.
Align BC Padder at 600 KC.
Align SW Trimmer at 15 MC.

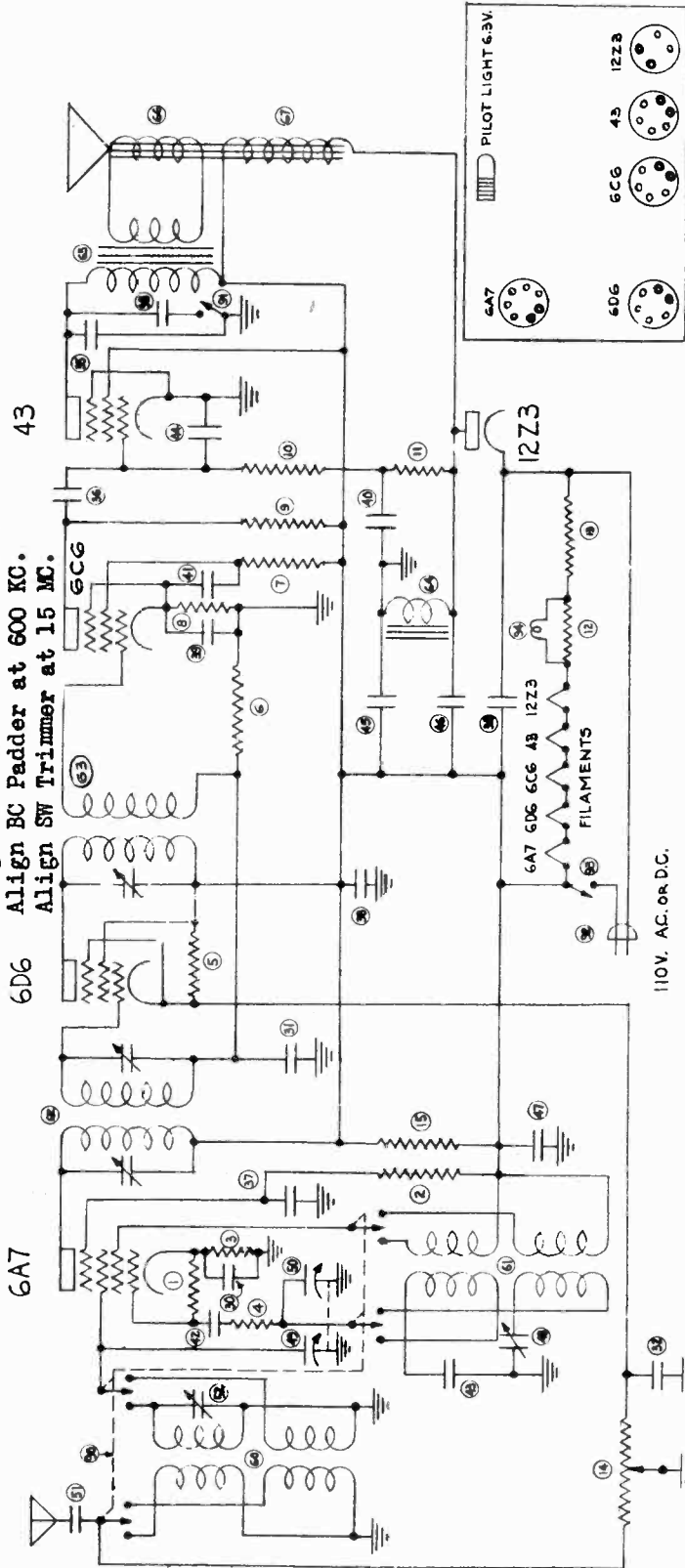

1	1242	RESISTOR	2,100 ^Ω	1/4 WATT	13	—	RESISTANCE	190 ^Ω	WITH 92	37	1040	CONDENSER	.05 M.F.	200V.	49	1206	{	VARIABLE COND.	.370 M.M.F.	90	1210	WAVE CHANGE SWITCH	
2	"	"	"	"	14	1209	VOLUME CONT.	25,000 ^Ω	"	"	38	1036	"	"	50	"	"	"	"	"	91	1203	TO NE CONTROL SWITCH
3	1243	"	260 ^Ω	"	"	39	1103	"	"	"	39	1103	"	"	51	1101	CONDENSER	.01 M.F.	400V.	92	1278	LINE CORD & PLUG WITH 19	
4	1276	"	110 ^Ω	"	15	1315	RESISTOR	5100 ^Ω	1/2 WATT	40	"	"	"	"	52	1107	ANT. TRIMMER COND.	.50 M.M.F.	93	—	LINE SWITCH WITH 14		
5	1245	"	51,000 ^Ω	1/2 WATT	"	"	"	"	"	41	1036	"	"	"	60	1211	ANTENNA COIL	"	"	94	1086	PILOT LIGHT BULB 6.3V.	
6	1094	"	1.1 MEG.	1/4 WATT	30	1040	CONDENSER	.05 M.F.	200V.	42	1099	"	260 M.M.F.	MICA	61	1212	OSCILLATOR COIL	"	"	"	"	"	"
7	"	"	"	"	"	"	"	"	"	43	1096	"	2500	"	62	1213	I.F. TRANSFORMER	45G K.C.	"	"	"	"	"
8	1027	"	31,000 ^Ω	"	32	"	"	"	"	44	1098	"	510	"	63	1316	I.F. TRANSFORMER	45G K.C.	"	"	"	"	"
9	1029	"	260,000 ^Ω	1/4 WATT	33	"	"	"	"	45	1320	"	ELEC. 8 M.F.	150V.	64	1281	FILTER CHOKE	"	"	"	"	"	"
10	1090	"	510,000 ^Ω	1/4 WATT	34	1102	"	.02	"	46	"	"	"	"	65	1279	OUTPUT TRANS.	4300 ^Ω	"	"	"	"	"
11	1165	"	260,000 ^Ω	"	35	1101	"	.01	"	47	"	"	"	"	66	1279	SPKR. VOICE COIL	"	"	"	"	"	"
12	1016	"	20 ^Ω	2 WATT	36	"	"	"	"	48	1104	PADDING COND.	250-400 M.M.F.	67	1104	FIELD COIL	4500 ^Ω	"	"	"	"	"	"

CIRCUIT DIAGRAM MODEL 530
DRAWN BY E. P. 7-13-34
CHECKED BY Andy
APPROVED BY JMS
HALSON NUMBER 530
HALSON RADIO MFG. CORP. N.Y.C.

MODEL 610
Schematic, Socket
Alignment

HALSON RADIO CORP.

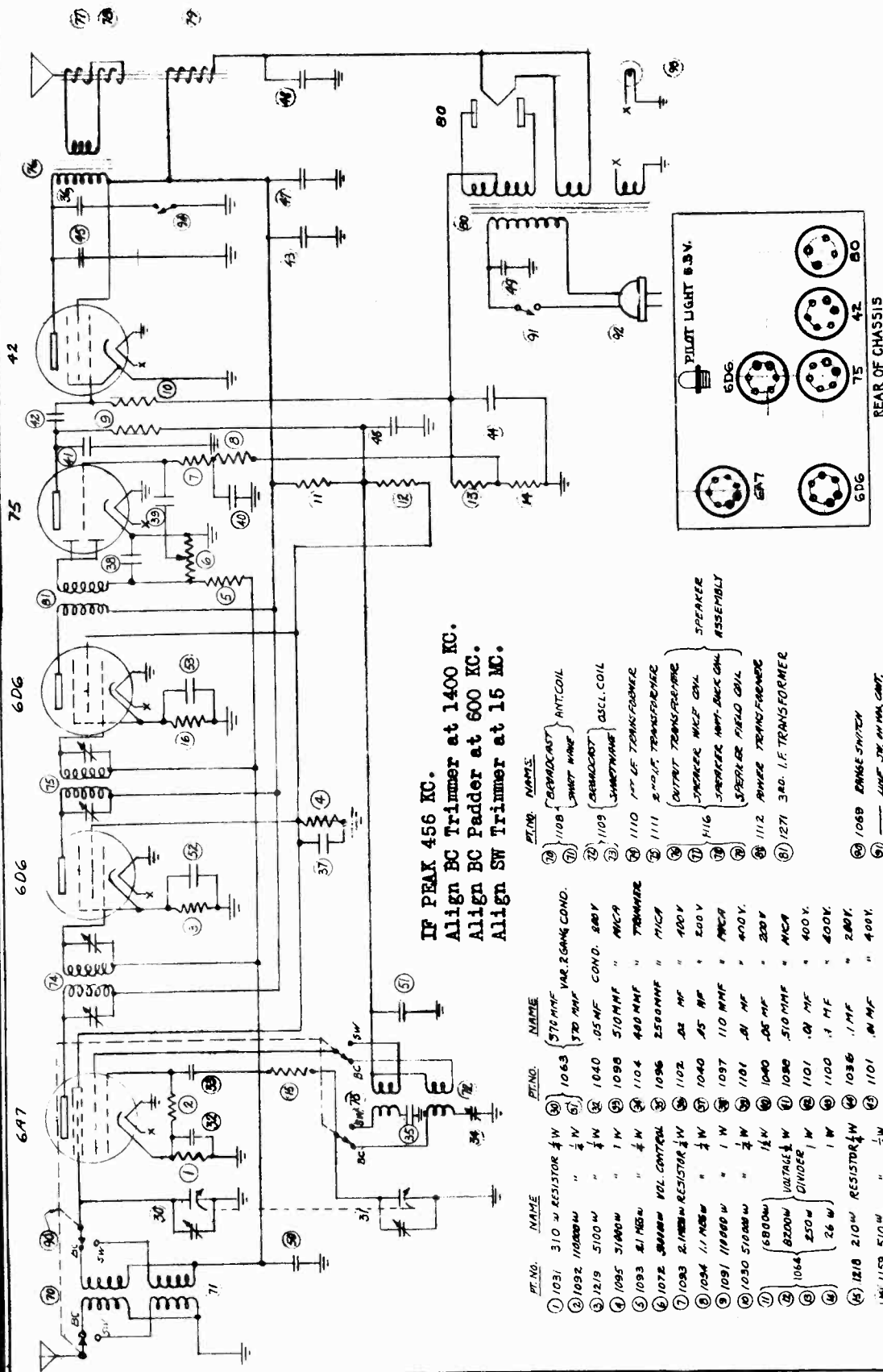

IF PEAK 456 KC.
Align BC Trimmer at 1400 KC.
Align BC Padder at 600 KC.
Align SW Trimmer at 15 MC.

PT. NO.	NAME	PT. NO.	NAME	PT. NO.	NAME
1031	310 W RESISTOR	1063	570 MFD VAR. 2 GANG COND.	1108	6.3V PILOT LIGHT
1029	5100 W "	1040	105 MFD COND.	1109	ANTICOID
1031	3100 W "	1098	510 MFD MICA	1110	1" 1/2 LF TRANSFORMER
1093	2.1 MEG W VOL. CONTROL	1096	2500 MFD "	1111	2" 1/2 LF TRANSFORMER
1093	2.1 MEG W RESISTOR	1102	25 MFD "	1112	300V TRANSFORMER
1034	11 MEG W "	1040	45 MFD "	1116	400V TRANSFORMER
1091	11000 W "	1097	110 MFD "	1116	SPEAKER W/CF OIL
1030	51000 W "	1101	1M MFD "	1116	SPEAKER W/CF OIL
1064	250W VOLTAGE DIVIDER	1101	1M MFD "	1112	300V TRANSFORMER
1210	2.10W RESISTOR	1036	1 MFD "	1127	300V TRANSFORMER
1159	510 W "	1101	1M MFD "	1089	RANGE SWITCH
		1102	25 MFD COND.	1115	LINE JUMPER
		1036	1 MFD COND.	1088	PILOT LIGHT
		1040	.05 "	1203	115V TONE CONT. SWITCH
		1040	.05 "		
		1040	.05 "		
		1040	.05 "		

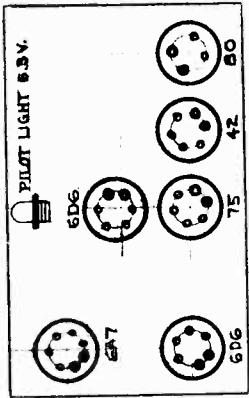

TITLE		CIRCUIT DIAGRAM MODEL 610	
SCALE	MATERIAL	FINISH	HALSON
DRAWN BY	CHECKED BY	APPROVED BY	
RLP 5/15/54			
HALSON RADIO MFG CORP	NYC		

HALSON RADIO CORP.

MODEL 620
Schematic, Socket
Alignment

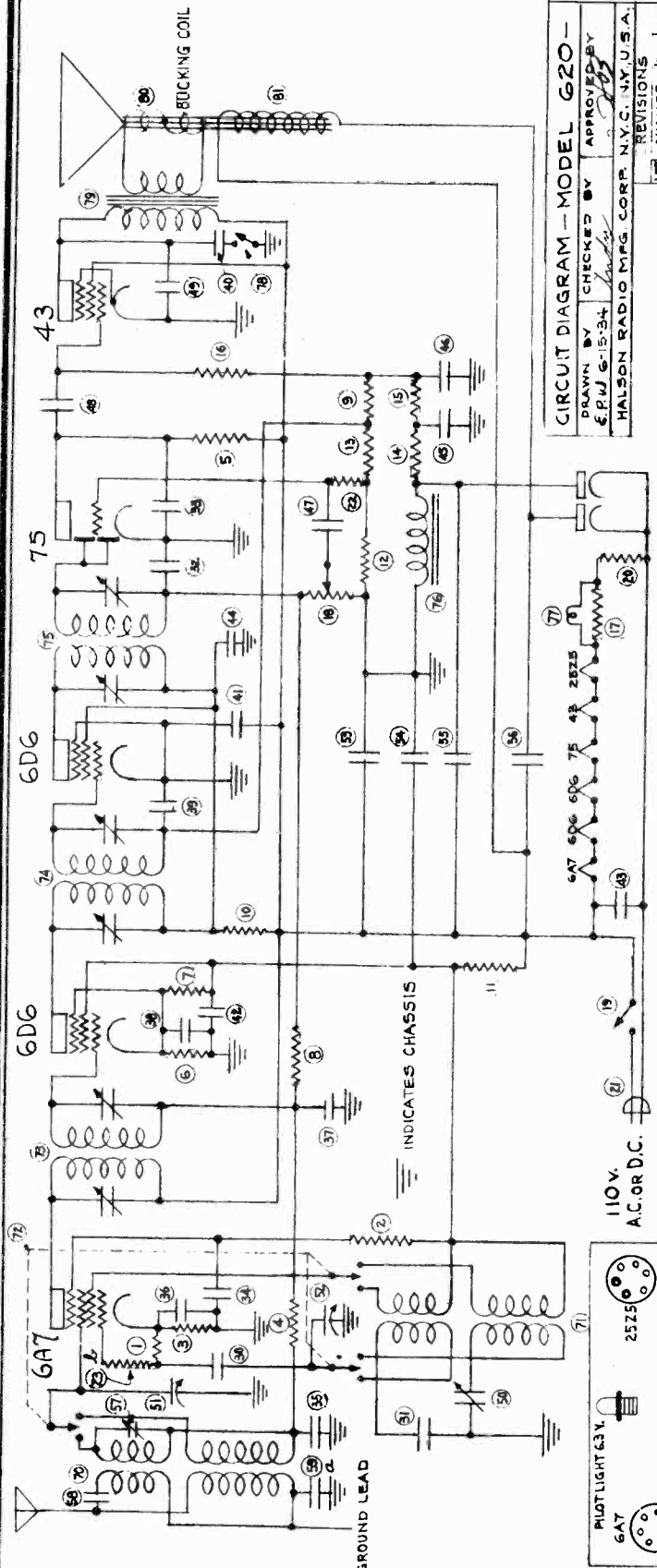

CIRCUIT DIAGRAM - MODEL 620 -
DRAWN BY CHECKED BY APPROVED BY
E.P.W. G.S.B. J.H.B.
HALSON RADIO MFG. CORP. N.Y.C. N.Y. U.S.A.

REVISIONS

REV.	CHANGE	DATE
a	added - 855	
b	added - 855	
	added - 825	
	110V - R.S.	7-3-34

IF PEAK 456 KC.
Align BC Trimmer at 1400 KC.
Align BC Padder at 600 KC.
Align SW Trimmer at 15 MC.

51	1063	VARIABLE COND.	370 M.M.F.
52	"	"	"
53	"	"	"
54	1230	ELECTROLYTIC COND.	8 M.F. 150V.
55	"	"	"
56	"	"	"
57	1237	ANT. TRIMMER COND.	5-30 M.M.F.
58	1097	CONDENSER	110 M.M.F. MICA
59	1238	ANTENNA COIL	"
60	1109	OSCILLATOR COIL	"
61	1069	WAVE CHANGE SWITCH	"
62	1250	I.F. TRANSFORMER	1B1 456 K.C.
63	74	"	2M9
64	75	1251	"
65	76	1231	FILTER CHOKS 450W
66	77	1086	PILOT LIGHT 6.3V.
67	78	1203	STONE CONTROL SWITCH
68	79	1252	OUTPUT TRANS. 4300W PRI. IMP.
69	80	SPKR.	VOICE COIL
70	81	ASSY.	FIELD COIL 2300W HOT

ITEM PART NO.	REAR OF CHASSIS NAME	VALUE
1	RESISTOR	21,000Ω ½ WATT
2	"	"
3	RESISTOR	260Ω ½ WATT
4	"	260,000Ω
5	"	"
6	RESISTOR	510Ω ½ WATT
7	"	51,000Ω ½ WATT
8	"	1.1 MEGΩ ½ WATT
9	"	"
10	CONDENSER	2,100M M.M.F. MICA
11	"	5,100M
12	"	310,000M
13	"	3.1 MEGΩ
14	"	110,000M
15	"	"
16	RESISTOR	1246 510,000Ω ½ WATT
17	"	1249 " " "
18	"	1240 VOL. CONT. 100,000Ω
19	"	LINE SWITCH
20	"	RESISTANCE 127Ω
21	"	LINE CORD & PLUG
22	"	RESISTOR 510,000Ω ½ WATT
23	"	1276 " " "
24	"	"
25	"	"
26	"	"
27	"	"
28	"	"
29	"	"
30	"	"
31	"	"
32	"	"
33	"	"
34	"	"
35	"	"
36	CONDENSER	1040 .05 M.F. 200V.
37	"	"
38	"	"
39	"	"
40	"	"
41	"	"
42	"	"
43	"	"
44	"	"
45	"	"
46	"	"
47	"	"
48	"	"
49	"	"
50	"	"
51	"	"
52	"	"
53	"	"
54	"	"
55	"	"
56	"	"
57	"	"
58	"	"
59	"	"
60	"	"
61	"	"
62	"	"
63	"	"
64	"	"
65	"	"
66	"	"
67	"	"
68	"	"
69	"	"
70	"	"
71	"	"
72	"	"
73	"	"
74	"	"
75	"	"
76	"	"
77	"	"
78	"	"
79	"	"
80	"	"
81	"	"
82	"	"
83	"	"
84	"	"
85	"	"
86	"	"
87	"	"
88	"	"
89	"	"
90	"	"
91	"	"
92	"	"
93	"	"
94	"	"
95	"	"
96	"	"
97	"	"
98	"	"
99	"	"
100	"	"
101	"	"
102	"	"
103	"	"
104	"	"
105	"	"
106	"	"
107	"	"
108	"	"
109	"	"
110	"	"
111	"	"
112	"	"
113	"	"
114	"	"
115	"	"
116	"	"
117	"	"
118	"	"
119	"	"
120	"	"
121	"	"
122	"	"
123	"	"
124	"	"
125	"	"
126	"	"
127	"	"
128	"	"
129	"	"
130	"	"
131	"	"
132	"	"
133	"	"
134	"	"
135	"	"
136	"	"
137	"	"
138	"	"
139	"	"
140	"	"
141	"	"
142	"	"
143	"	"
144	"	"
145	"	"
146	"	"
147	"	"
148	"	"
149	"	"
150	"	"
151	"	"
152	"	"
153	"	"
154	"	"
155	"	"
156	"	"
157	"	"
158	"	"
159	"	"
160	"	"
161	"	"
162	"	"
163	"	"
164	"	"
165	"	"
166	"	"
167	"	"
168	"	"
169	"	"
170	"	"
171	"	"
172	"	"
173	"	"
174	"	"
175	"	"
176	"	"
177	"	"
178	"	"
179	"	"
180	"	"
181	"	"
182	"	"
183	"	"
184	"	"
185	"	"
186	"	"
187	"	"
188	"	"
189	"	"
190	"	"
191	"	"
192	"	"
193	"	"
194	"	"
195	"	"
196	"	"
197	"	"
198	"	"
199	"	"
200	"	"

MODEL 630
Schematic, Socket
Alignment

HALSON RADIO CORP.

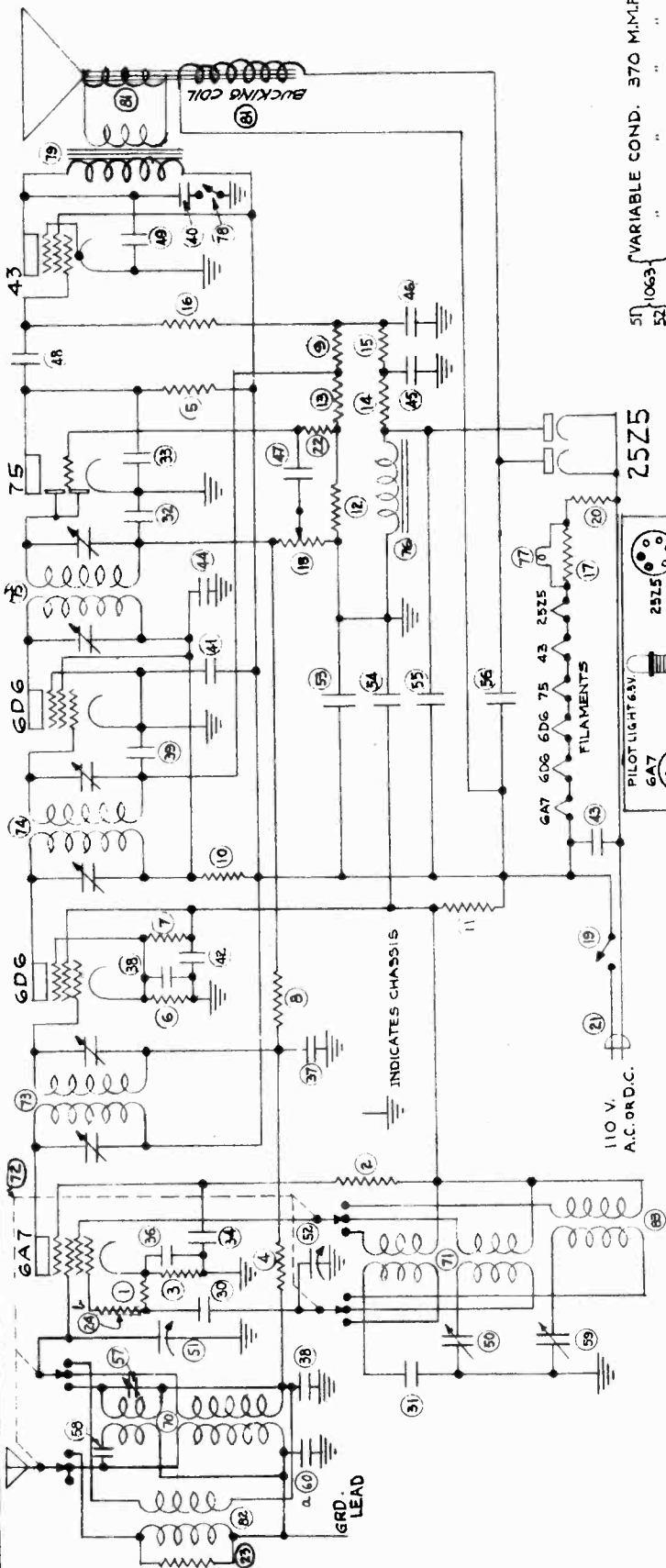

IF PEAK 456 KC.
Align BC Trimmer at 1400 KC.
Align BC Padder at 600 KC.
Align SW Trimmer at 15 MC

- 51 VARIABLE COND. 370 M.M.F.
- 52 " " " " " "
- 53 ELECTROLYTIC COND. 8 M.F. 150V.
- 54 " " " 16 " " "
- 55 " " " 8 " " "
- 56 " " " 4 " " "
- 57 1262 ANT. TRIMMER COND. 5-20 M.M.F.
- 58 1097 CONDENSER 110 M.M.F. MICA
- 59 1262 " " " 50 TO 120 M.M.F.
- 60 1102 " " " .02 M.F. 400V.
- 70 1238 ANTENNA COIL
- 71 1109 OSCILLATOR COIL
- 72 1069 WAVE CHANGE SWITCH
- 73 1250 I.F. TRANSFORMER 1ST 456 K.C.
- 74 " " " 258 " "
- 75 1251 " " " 388 " "
- 76 1231 FILTER CHOKE 430W
- 77 1086 PILOT LIGHT 6.3V.
- 78 1203 TONE CONTROL SW.
- 79 1252 OUTPUT TRANS. 4300W PRI. IMP.
- 80 5PKR VOICE COIL
- 81 855Y FIELD COIL 2300W HOT
- 82 1264 L.W. ANT. COIL
- 83 1265 L.W. OSC. COIL

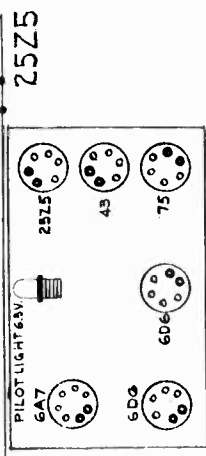

ITEM PARTNO.	NAME	REAR OF CHASSIS
1	1242 RESISTOR 21,000W 1/4 WATT	36 1040 CONDENSER 05 M.F. 200V. & 60 1102
2	" " " " " "	" " " " " "
3	1243 " " 260W " "	37 " " " " " "
4	1165 " " 260,000W " "	38 " " " " " "
5	" " " " " "	39 " " " " " "
6	1159 " " 510W " "	40 " " " " " "
7	1245 " " 51,000W 1/2 WATT	41 1103 " " " " " "
8	1094 " " 1.1MEG 1/4 WATT	42 " " " " " "
9	" " " " " "	43 " " " " " "
10	1032 " " 2,100W " "	44 1036 " " " " " "
11	1244 " " 5100W " "	45 " " " " " "
12	1246 " " 310,000W " "	46 " " " " " "
13	1248 " " 31MEG " "	47 1101 " " " " " "
14	1092 " " 110,000W " "	48 " " " " " "
15	" " " " " "	49 " " " " " "
		50 1104 PADDING COND. 250-400M.F.

CIRCUIT DIAGRAM - MODEL - 630
DRAWN BY P. PULG-22-34
CHECKED BY ANDY
APPROVED BY [Signature]
HALSON RADIO MFG. CORP. N.Y.C. N.Y.

REV.	CHANGE	DATE	NAME
1	60-.02 M.F. added		
2	24-110W	7-3	EPD

HAMMARLUND MFG. CO.

MODEL "Comet Pro" AVC Schematic, Voltage

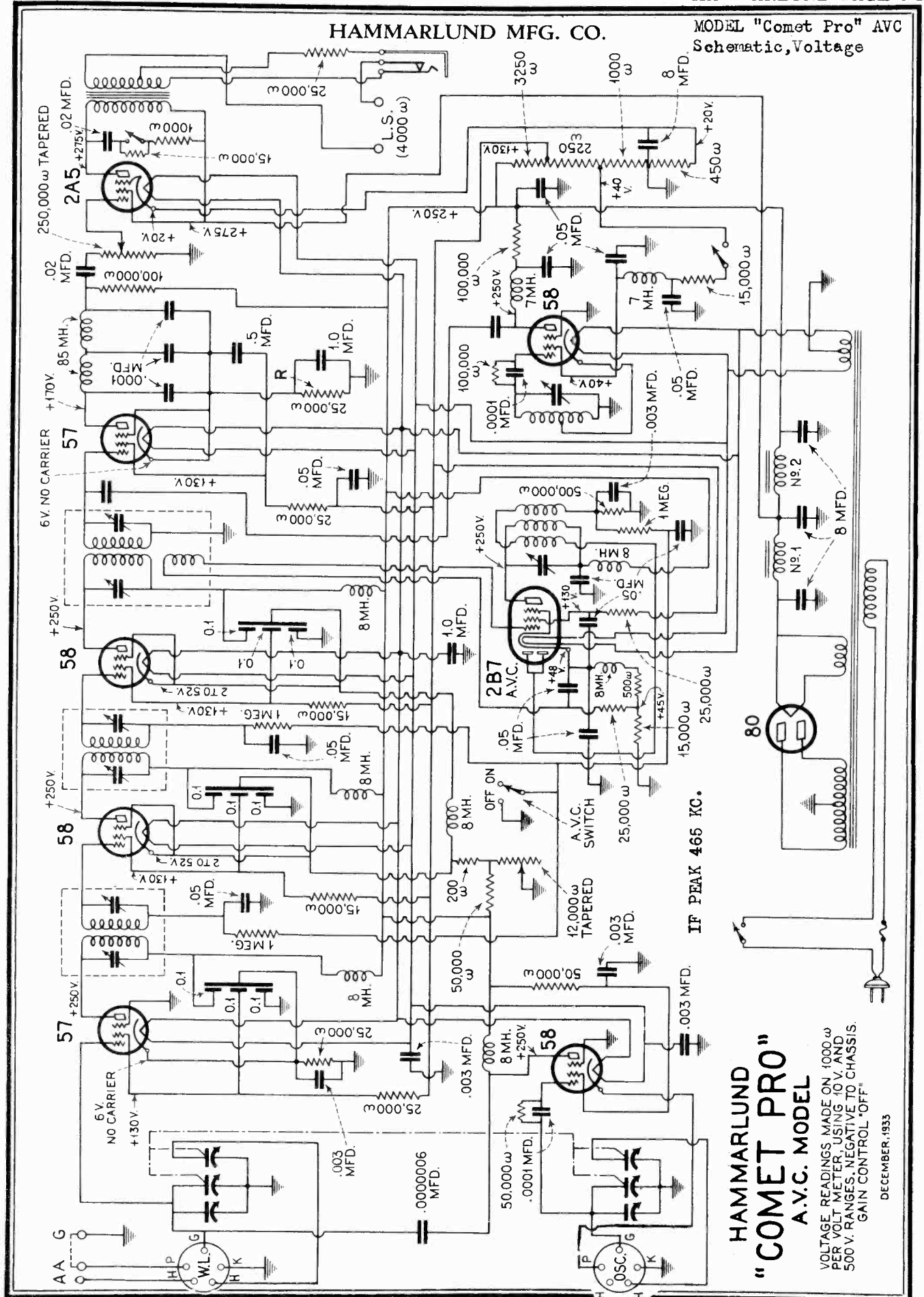

IF PEAK 465 KC.

HAMMARLUND "COMET PRO" A.V.C. MODEL

VOLTAGE READINGS MADE ON 1000Ω PER VOLT METER, USING 10V. AND 500V. RANGES, NEGATIVE TO CHASSIS. GAIN CONTROL "OFF".

DECEMBER, 1933

MODEL "Comet Pro" AVC
Alignment, Socket

HAMMARLUND MFG. CO.

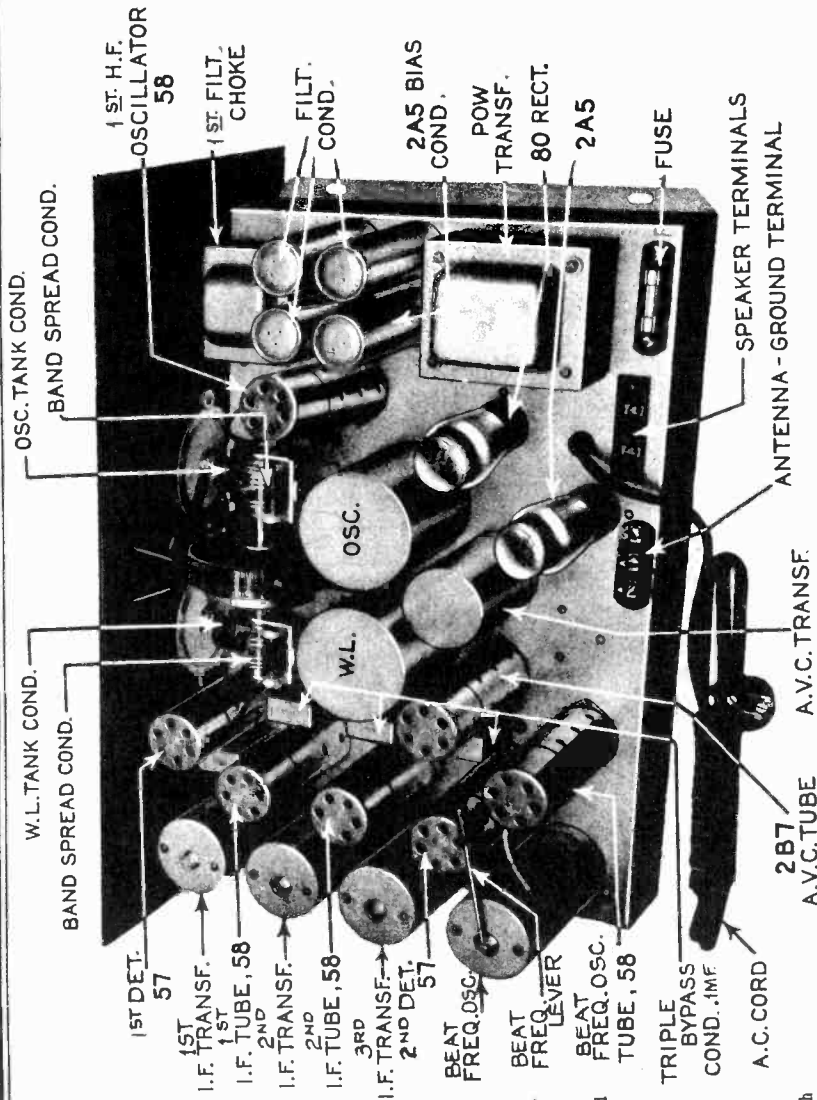

Should it be necessary to remove the Comet "Pro" chassis from its shield cabinet it is easily accomplished by removing the four machine screws which extend through the bottom of the cabinet and the twelve screws around the edge of the front panel. The entire panel and chassis assembly may then be slipped out of the cabinet by drawing it forward. When thus removed all parts and wiring located beneath the chassis are exposed for examination or test. The shield cans found under the chassis may be removed if necessary by pulling them off.

First remove the chassis from the cabinet and prop it up on its rear edge so that both the top and bottom are accessible. Then connect the 10 ohm range of a 1000 ohm per volt voltmeter across the 25,000 ohm resistor between the cathode of the second detector and ground. This resistor is marked "R" in the schematic diagram.

This meter will function as a resonance indicator, showing maximum deflection when exact resonance is obtained.

Next provide a signal source. If an oscillator is available, tune it to 465 kc. and couple it to the receiver. If such an oscillator is not at hand the carrier of a fairly powerful station may be employed provided the station selected is one which is free from fading and interference. This signal should be tuned in on the receiver in the usual way and the gain control adjusted to cause an increase of about 2 volts in the voltmeter reading.

The actual alignment can now proceed. First adjust the bottom condensers of the three i.f. transformers. These are accessible from the under side of the chassis. Adjust them one after the other until maximum deflection of the resonance indicating meter is obtained. If the meter reading increases mate-

rially during this process retard the gain control to bring it back to the original plus 2 volts reading. Then make a similar adjustment of the condensers at the tops of the three i.f. transformers. Finally repeat this whole process, readjusting each condenser a second time to insure exactness of resonance.

After the i.f. stages are thus accurately lined up, turn on the heterodyne-beat oscillator and set its top lever so that it points diagonally away from the rear right-hand corner of the chassis. Then adjust the bottom adjustment screw on this transformer for exact zero beat. When this has been accomplished the receiver is in accurate alignment.

HERBERT H. HORN

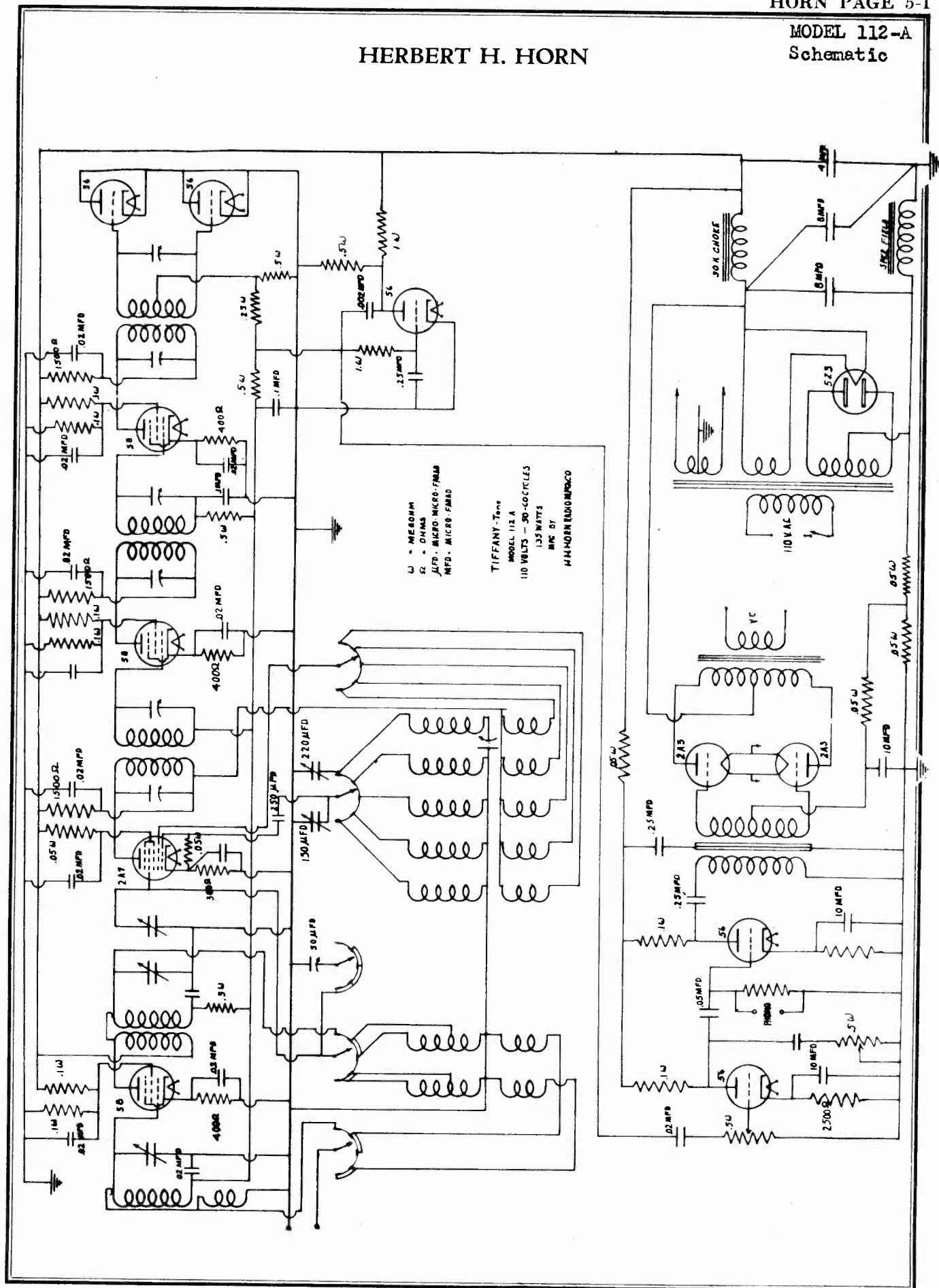

MODEL 58,158
Schematic, Socket
MODEL 156
Schematic, Socket
MODEL 1934

HERBERT H. HORN

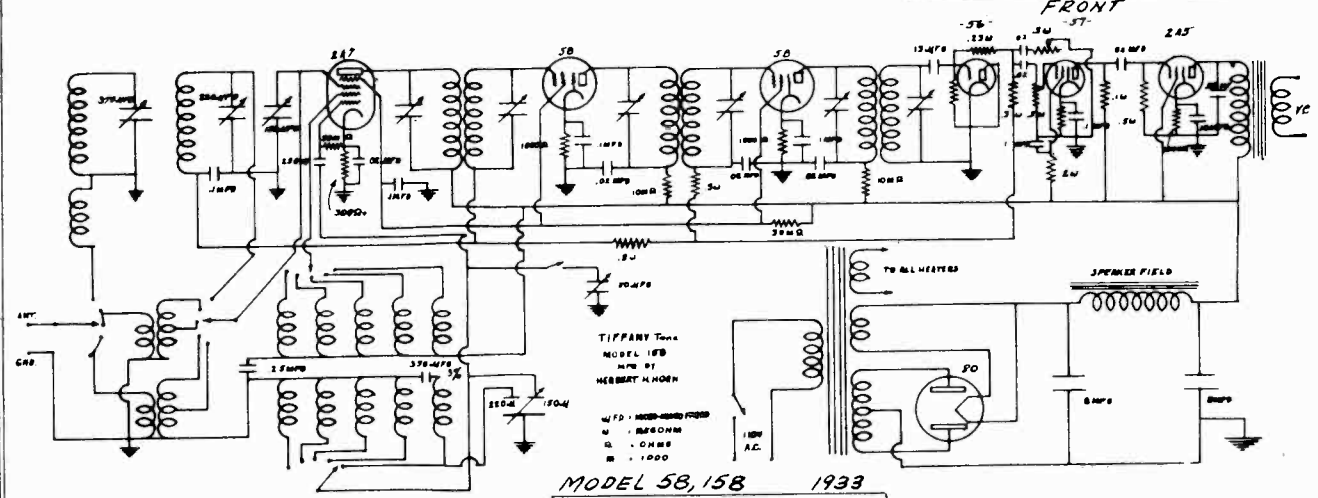
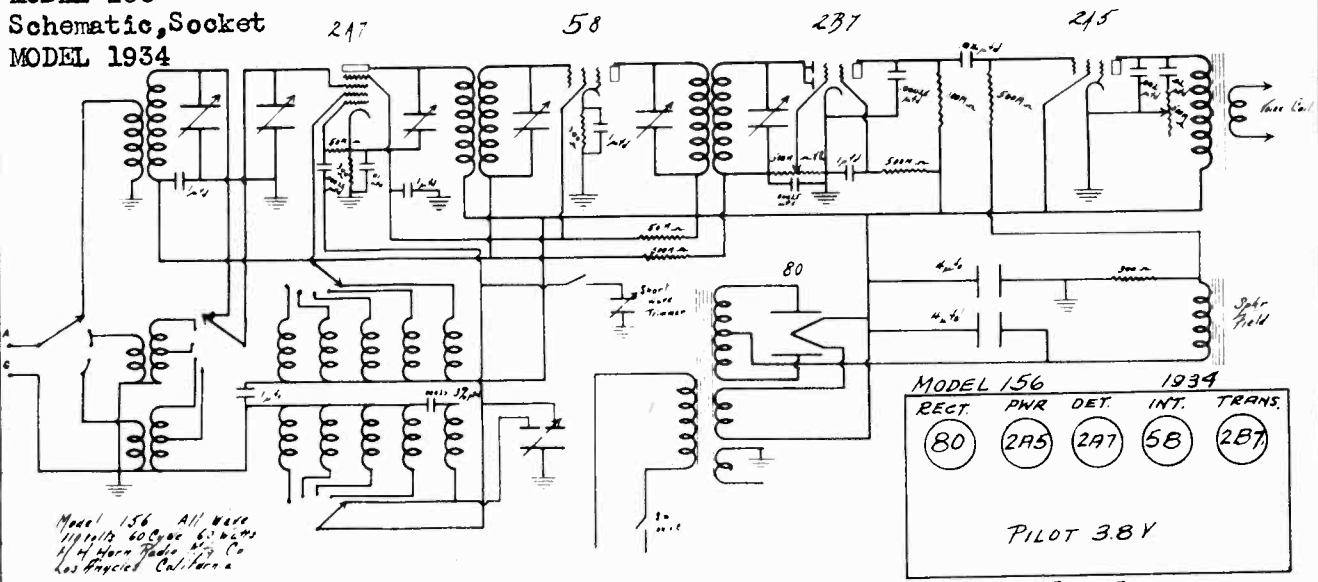

MODEL 58,158 1933

1F (58)	(56)	(56)	(2A5) PWR
	DIODE	AF	
(58) I.F.			(80) RECT.
(2A7) TRANS			

DIAL 3.8V
FRONT.

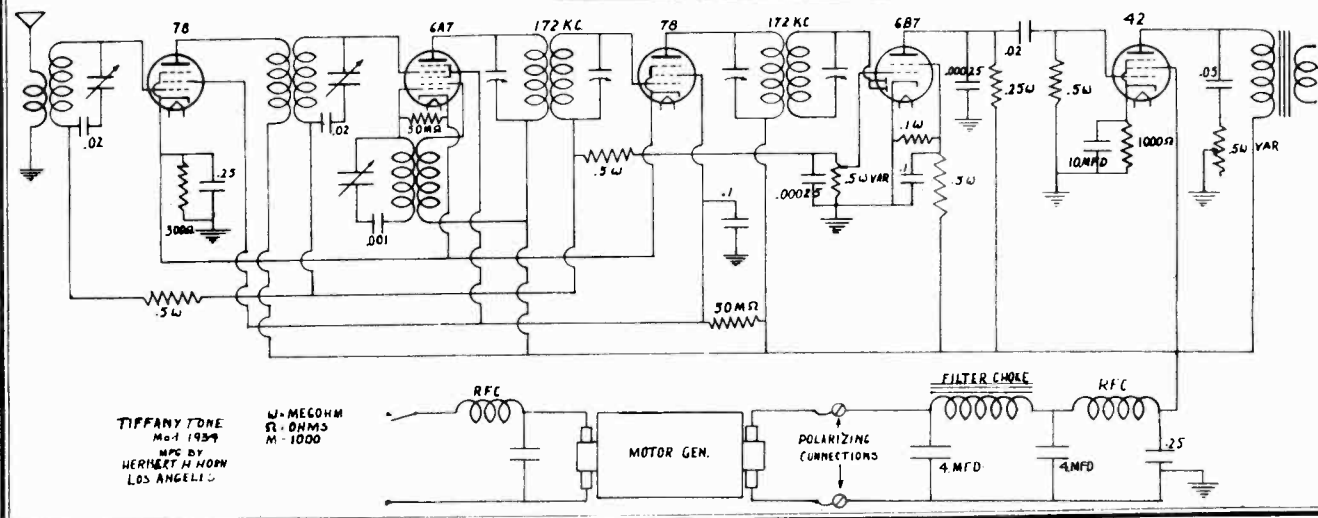

HOWARD RADIO CO.

MODEL R-9
Schematic

VOLTAGES GIVEN ARE TAKEN FROM THE VARIOUS POINTS TO GROUND WITH LINE VOLTAGE AT 115 V A.C.

I.F. PEAK AT 465 KC

BAND SWITCH IS SHOWN AS VIEWED FROM BACK WITH CROSSIS TURNED OVER.

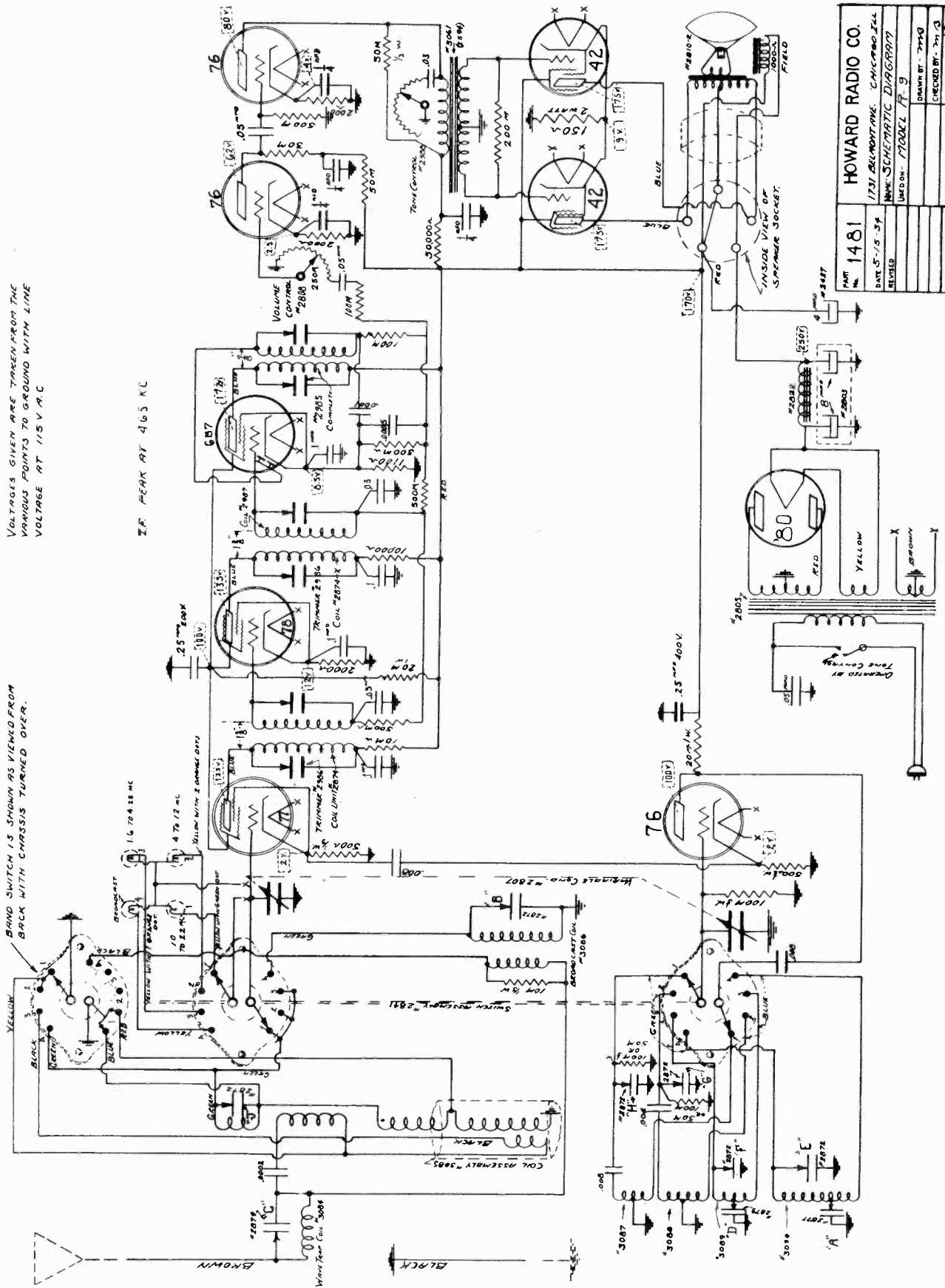

PART No. 1481		HOWARD RADIO CO.	
DATE 5-15-34		1731 BELMONT AVE. CHICAGO 24, ILL.	
REVISED		MKS. SCHEMATIC DIAGRAM	
		USED ON - MODEL R-9	
		DRAWN BY - TPKB	
		CHECKED BY - TPKB	
		APPROVED BY - J.R.	

MODEL R-9
Parts Layout
Socket Layout
Trimmers

HOWARD RADIO CO.

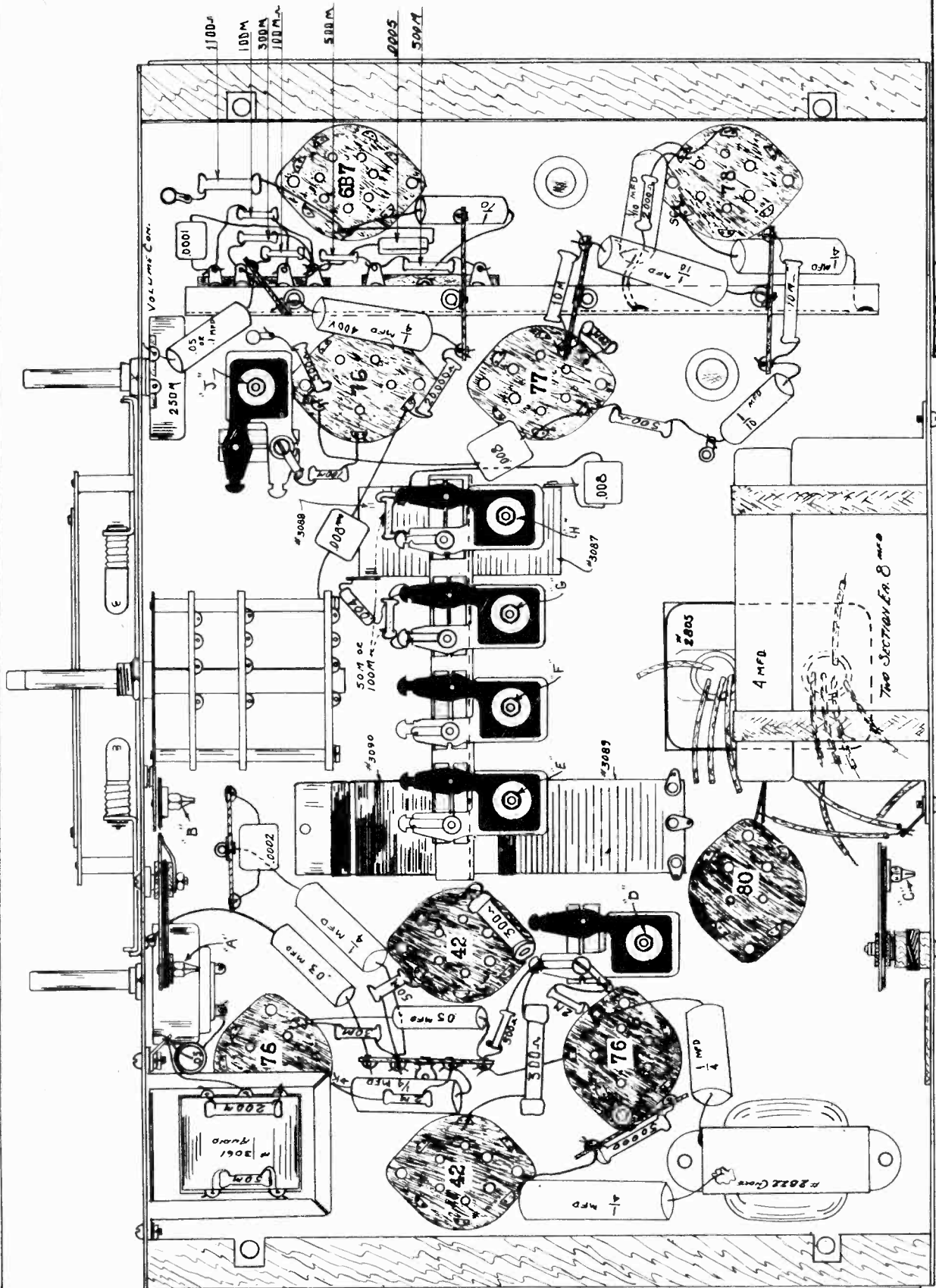

1473
 APR 5-15-34

HOWARD RADIO CO
 1731 BELMONT ST. CHICAGO ILL.
 MODEL - R-9 Pictorial
 DWG - 7733 APPROVED - IIR

HOWARD RADIO CO.

MODEL R-9
AlignmentNOTES

- (1) One of the sections of the gang condenser is not used.
- (2) The two lower pilot light bulbs may be changed when necessary by loosening the screw holding the light bracket and it will pull out to the side. It is not necessary that the chassis be taken out of the cabinet.
- (3) It is important that the chassis is made to float as freely as possible within the cabinet.
- (4) When adjusting the oscillator circuits be sure to start on the right signal. The best procedure is to turn the trimmer all the way out and then pick the strongest signal when tuning in. If the oscillator happens to be on the wrong side, the set will be very insensitive around the center of the band.
- (5) Keep the input low from the signal generator when making the various adjustments, to prevent overloading.

The alignment of the I.F.'s; the intermediate frequency is 465 KC and the stages are aligned in the customary manner by adjusting the trimmers in the top of the IF cans for the maximum deflection with 465 KC input.

The Alignment of the Oscillator Circuits;

Before making any adjustments be sure that the hand is directly over the first line above 550 (which would be about 540) when the variable condenser is turned to maximum capacity.

- I Starting with the 1st Short Wave Band (1.6 to 4 Megacycles)
 - (1) Set your signal generator to 4 MC.
 - (2) Set dial to 4 MC.
 - (3) Then peak oscillator Trimmer (lettered "F" on the pictorial diagram) to the signal.
 - (4) Set generator to 1.6 MC.
 - (5) Set dial to 1.6 MC.
 - (6) Peak Oscillator Padding Condenser lettered "D" to signal.
 - (7) Reset generator and dial back to 4 MC and check any variation.
- II Second (2) S.W. Band, 4 to 12 MC.
 - (1) Set Generator and dial to 12 MC. Peak Oscillator trimmer lettered "G" for 12 MC.
 - (2) Cut down the signal generator to a very weak input in to the set, and adjust the RF trimmer lettered "J" at 12 MC.
- III The 3rd S.W. Band 10 to 22 MC.
 - (1) Set generator and dial to 20 MC.
 - (2) Peak Oscillator trimmer lettered "H" at 20 MC.
- IV The Broadcast band is aligned by;
 - (1) Adjusting trimmer "E" at 1400 KC.
 - (2) Peak Padding Condenser "A" at 600 KC.
 - (3) Adjust trimmer "B" across secondary winding of RF coil to peak at 1400 KC.
- V The wave trap (Trimmer "C") is adjusted to a minimum setting with 465 KC fed in to the Antenna.

MODEL W
Power Amplifier
Schematic

HOWARD RADIO CO.

ALL VOLTAGE READINGS TAKEN FROM
VARIOUS POINTS TO GROUND WITH 1000-
PER VOLT METER AND WITH LINE VOLTAGE
AT 115V. AC

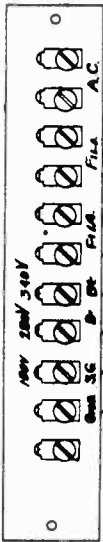

- B⁺ CIRCUITS CODED**
- SCREEN GRID RED
 - GROUND BLUE
 - GRID RETURN BLACK
 - PLATE GREEN & WHITE
 - FILAMENT RED & WHITE
 - CATHODE YELLOW
 - GRID ORANGE
 - GRID GREEN

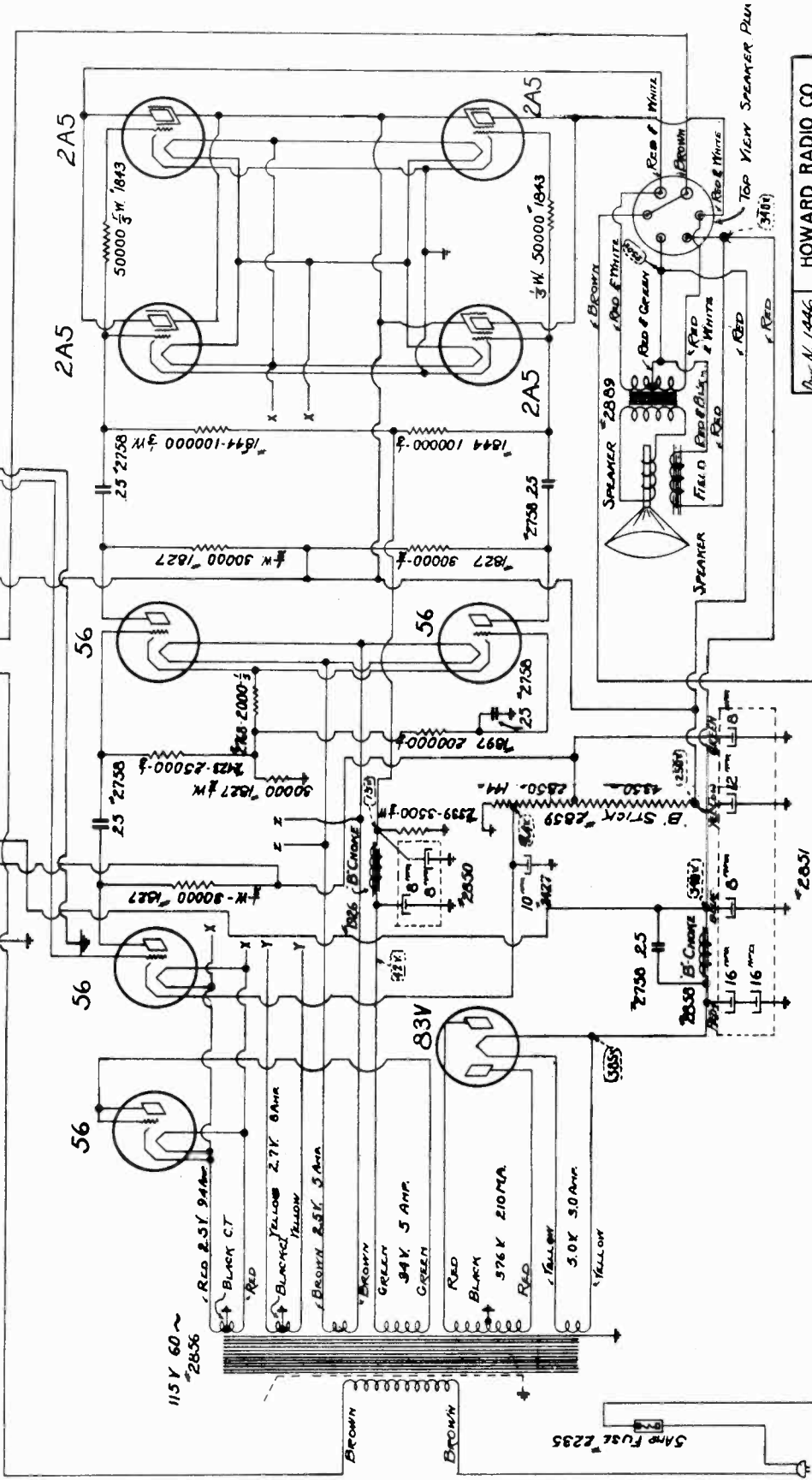

Spec. No. 1446	HOWARD RADIO CO.
DATE 2-10-34	SOUTH HAVEN - MICHIGAN
1-19-34	WAS SCHEMATIC POWER PACK
	USED ON MODEL W, 2735, 2736
	DESIGNED BY J. A. LAY
	CHECKED BY J. K. S.
	APPROVED BY J. T.

MODEL W
Receiver
Socket Layout
Trimmers

HOWARD RADIO CO.

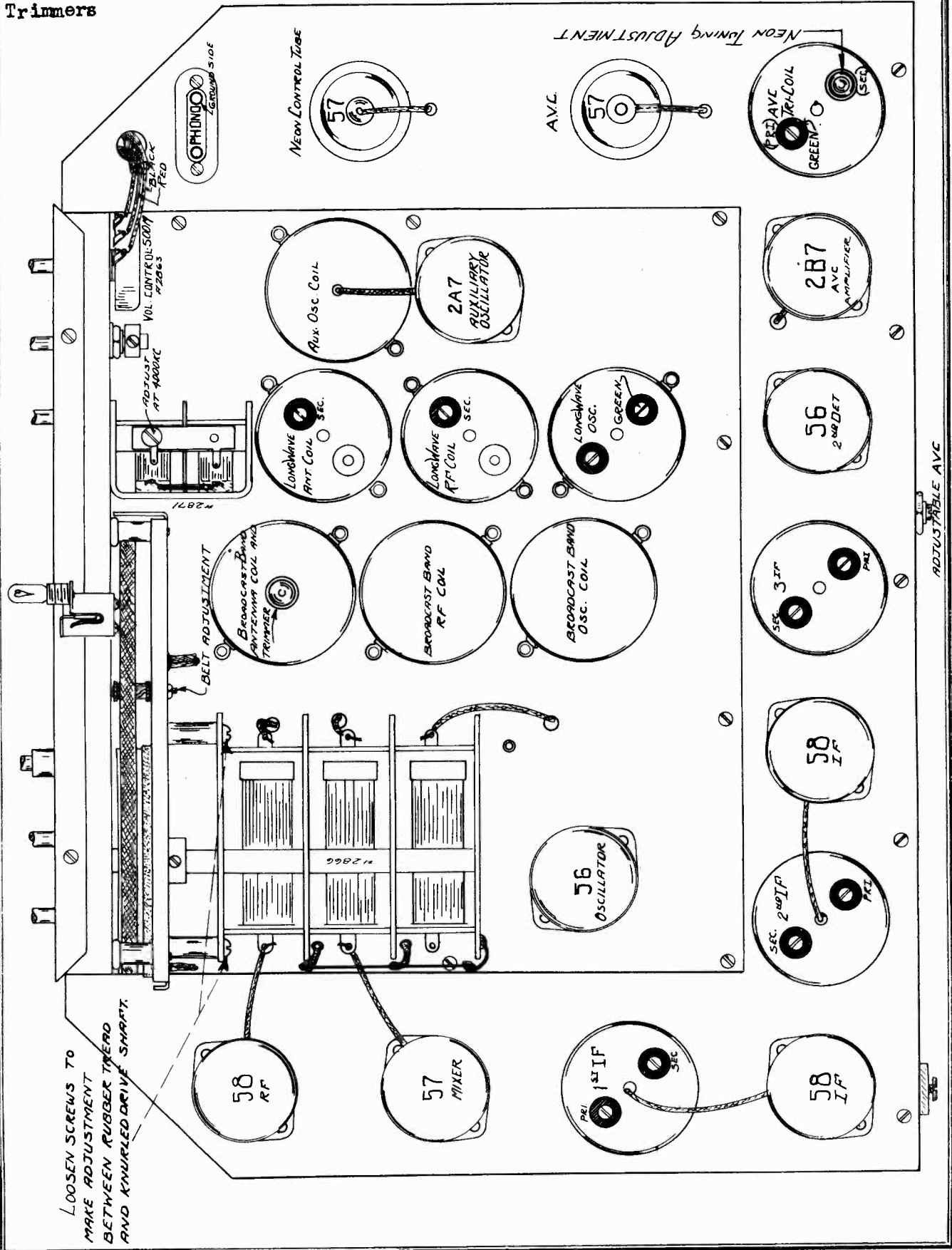

HOWARD RADIO CO.

MODEL W
Notes, Alignment

In the top of the coil can assembly in upper right hand corner (facing rear of tuner) will be found an adjustment. This adjustment is the one located in top next to neon adjustment.

Watching voltmeter, set the above adjustment with insulated screw driver until a maximum reading is obtained on voltmeter.

The AVC circuit has been fundamentally adjusted by the above procedure and should be set for the locality in which set is to be operated, in accordance with adjustment number 8.

8. AVC ADJUSTMENT FOR VARIOUS LOCALITIES

In certain localities especially close to a broadcast station, it may be necessary to readjust the AVC (slotted shaft) control.

In order to properly make this adjustment, tune the receiver in exact resonance with the most powerful station to be received. Then if the station's signals sound "fuzzy" or rough, turn the control to the right until this condition stops. Do not turn this control beyond this point.

9. NEON TUNING INDICATOR

Facing the back of tuner chassis, extending through one of the tall shielded assemblies in the upper right hand corner, will be found a small black knurled knob. This knob is used to adjust the Neon resonance indicator. Due to the fact that in some localities the signal strength from certain stations varies somewhat, it is advantageous to be able to set this adjustment.

At the time of day during which the station signals are the most powerful (usually in the evening) adjust the receiver dial to a powerful station, then turn the neon adjustment until the light just fills the opening in arrow of dial. Then readjust the tuning dial of receiver. Should the light become more brilliant, leave the dial at point of highest brilliancy and again readjust neon indicator until it just fills the arrow opening.

A little practice will enable the user to set this indicator to meet the individual requirements.

When once adjusted for the locality in which the receiver is to be used, it should not have to be readjusted.

Since the inter-station silent tuning system is a proportional function of the neon light, the inter-station silent tuning system will be correctly adjusted.

The neon light system is not intended to work on the short wave stations. However, on the more powerful signals it will generally give an indication of resonance.

There are two important things to keep in mind when adjusting this receiver,

1. Since all adjustments are made with AVC inactive, extreme care must be used to attenuate the input signal low enough so that there will be no overloading of tube amplifiers while making adjustments. If the input signal voltage is attenuated to the point where the speaker voice coil power does not exceed 50 or 75 milliwatts no trouble will be experienced from this source.

2. After the high frequency adjustments have been made on short wave bands, the test oscillator or generator should be advanced to 930 KC higher in frequency - the output voltage of generator advanced considerably and notice of the image signal of receiver oscillator falls at this point. In case this signal is not heard, the adjustment of the receiver oscillator has been incorrectly made. An example:

After the third shortwave band has been adjusted at 20 m.c. it should be possible to move the test oscillator to 20, 930 KC and hear the signal.

6. THE ALIGNMENT OF THE FREQUENCY METER

- (a) Turn main dial to where 4800 KC comes in. This may be checked by your signal generator. The signal generator is not used, however, in aligning the Frequency Meter.
- (b) Make certain the hand on the Frequency Meter falls on 1.5 when the 2-gang condenser is at full capacity.
- (c) Turn the oscillator switch all the way to the right to the Modulator position.
- (d) Turn frequency dial to 4 and adjust the trimmer on the two-gang variable condenser to resonance with the main dial setting.
- (e) Turn band indicator switch to first short wave band (1.5 to 3.5)
- (f) Set the main dial to where 1500 KC comes in, which is at the .55 figure (as mentioned before).
- (g) Turn frequency dial to 1.5 and adjust Trimmer No. 15 for maximum signal.

7. AVC ADJUSTMENT

Looking at the bottom view drawing #1416, there will be noted a terminal of the AVC control marked "Z". Connect the negative terminal of a high resistance voltmeter (1000 ohms per volt at least, using a medium voltage scale) to this terminal marked "Z". Connect the positive side of voltmeter to chassis ground.

Adjust the receiver to a signal having approximately two or three thousand microvolt intensity (Note: a fairly powerful local station may also be used for this).

MODEL W

I-F Alignment

R-F, Osc. Alignm't.

HOWARD RADIO CO.

2. THE BROADCAST BAND

It is necessary on the broadcast band only that a metal bottom with holes in line with the trimmer nuts be used so that the circuits will not be detuned when the regular bottom plate is screwed back on.

- (a) Turn band indicator to Broadcast .55 to 1.5
- (b) Set dial to 1.4
- (c) Feed in 1400 KC and adjust trimmer No. 14 (see pictorial diagram, bottom view) for resonance.
- (d) Adjust RF and antenna stages. The RF is No. 7, and the Antenna Trimmer consists of the knurled knob extending from the top of the Antenna Coil Can.
- (e) Rotate dial to .55 and adjust trimmer No. 10 for resonance with 550 KC.
- (f) Recheck the settings at 1400 and bend plates of variable condenser at 950 or other points where necessary for KC reading on dial.

3. THE FIRST SHORT WAVE BAND

- (a) Turn band indicator to 1.5 to 3.5.
- (b) Set dial to 3.5
- (c) Feed in a 3500 KC signal and adjust Trimmer No. 13 for resonance.
- (d) Adjust RF and Antenna stages, Trimmers Nos. 3 and 6
- (e) Rotate dial to where the hand points to .55 on the broadcast band. The dial calibration may be found to be slightly off at this point and the .55 figure corresponds to 1.5 on the First Short Wave Band. Feed in 1800 KC and adjust Trimmer No. 9 for Resonance.

- (f) Recheck setting at 3500 KC.

4. THE SECOND SHORT WAVE BAND

- (a) Turn band indicator to 3.5 to 9
- (b) Set dial to about 8.9. The calibration is slightly off at this point and the 8.9 figure corresponds to 8.5
- (c) Feed in 8500 KC and adjust Trimmer No. 12 for resonance
- (d) Adjust RF and Antenna stages with Trimmers Nos. 3 and 2
- (e) Rotate dial to 3.5 and adjust Trimmer No. 8 for resonance with 3500 KC
- (f) Recheck setting at 8.5 (8.9).

5. THE THIRD SHORT WAVE BAND

- (a) Turn band indicator to 9 to 21
- (b) Set the dial to 20
- (c) Feed in 20000 KC signal and adjust oscillator trimmer No. 11 for resonance
- (d) Adjust RF and Antenna stages, trimmers Nos. 1 and 4
- (e) The alignment at 9 is obtained by use of the fixed condensers. This should not require any change.
- (f) In order to make the band more sensitive where most of the foreign reception is obtained, it is advisable to turn the dial to 12 on the third band and readjust the Antenna coil trimmer (No. 1) to peak at 12000 KC.

THE PROCEDURE TO ALIGN THE I.F. STAGES

The IFs are aligned in the usual system of feeding the intermediate frequency of 465 KC into the grid of the 57 1st Detector tube.

Make certain that the AVC adjustment (which is the slotted shaft extending from the back of the chassis) is turned all the way to the left when gaining the IF, RF or oscillator circuits.

The two trimmers in each of the three IF Coil Cans should be very carefully tuned to resonance as they are very critical and will greatly affect the performance of the receiver.

The sensitivity of the IF stages should be between 10 and 20 Microvolts.

ALIGNING THE R.F. AND OSCILLATOR CIRCUITS

After the IFs are aligned, the various circuits may be aligned in the order given below.

Keep the AVC adjustment all the way off to the left as before.

It is not necessary that the oscillator be taken out of its socket when aligning any of the RF circuits.

Always adjust the oscillator stage before the RF in any particular band.

Be sure to start on the right signal when adjusting the oscillator trimmer. The best procedure is to turn the trimmer all the way out and then pick the strongest signal when turning in. If the oscillator happens to be on the wrong side, the set will be very insensitive around the center of the dial.

The plates on the variable condenser should be bent to make the KC readings on the dial line up ONLY on the Broadcast Band.

Before adjusting any band, make certain that the pointer of the station indicator is set on the last black line when the dial is turned all the way to the left on the broadcast band just above .85 -- at this point the variable condenser should be all the way in to maximum capacity.

1. THE LONG WAVE

- (a) Turn the band indicator to .15 to .35
- (b) Set dial to .35
- (c) Feed 350 KC into the antenna post and adjust the trimmer in the long wave oscillator can for resonance. The correct trimmer for this adjustment is the one that is not green coded on the trimmer washer. (Refer to pictorial diagram, top view).
- (d) Adjust RF and antenna stages. There is only one trimmer for each.
- (e) Rotate dial to just above .17 and adjust the oscillator trimmer that is coded green, for resonance with 175 KC.
- (f) Recheck the 350 KC setting.

HOWARD RADIO CO.

MODEL W
Power Amp. Notes
Parts List

REPLACEMENT PARTS LIST OF "W" (EXPLORER) TUNER

Part No.	Name	Unit	Price Ea.
2895	1st IF complete	1	\$ 1.10
2895	2nd IF complete	1	1.10
2895	3rd IF complete	1	1.10
2891	Tri Coil Assembly complete	1	1.10
S11140	Broadcast Antenna Coil complete	1	1.10
S11141	Broadcast RF Coil complete	1	1.00
S11142	Broadcast OSC Coil complete	1	1.10
S11144	Short Wave #1 Band Antenna Coil	1	.90
S11145	Short Wave #1 Band RF Coil	1	.90
S11146	Short Wave #1 Band OSC Coil	1	.90
S11147	Short Wave Band #2 Antenna Coil	1	.90
S11148	Short Wave Band #2 RF Coil	1	.90
S11149	Short Wave Band #2 OSC Coil	1	.90
S11150	Short Wave Band #3 Antenna Coil	1	.85
S11151	Short Wave Band #3 RF Coil	1	.85
S11152	Short Wave Band #3 OSC Coil	1	.85
S11154	Auxiliary OSC Coil	1	.75
S 2889	Long Wave Antenna Coil Assembly	1	1.10
SA2939	Long Wave RF Coil Assembly	1	1.10
S11143	Long Wave OSC Coil Assembly	1	1.20
2872	Two Plate Trimmer	12	.25
2877	Seven Plate Trimmer	2	.35
2879	Nine Plate Trimmer	1	.35
2364	Oscillator Switch	1	.30
2863	Volume Control 500,000 ohm.	1	.75
2890	10,000 ohm Noise suppressor	1	.75
2862	500,000 Ohm tone control and switch	1	1.00

10. THE POWER AMPLIFIER
The Power Amplifier schematic diagram will clearly give all information that is needed from a servicing standpoint.
The tuner is coupled to the audio by the 56 tube, resistance coupled to two 56 drivers into the four push-pull parallel 2A5s.
The rectifier circuit uses the 83V tube for the B Supply.
However, the bias voltage for the 2A5s is obtained by an additional rectifying circuit comprising the 56 tube and additional choke and filter.

11. VARIOUS MECHANICAL ADJUSTMENTS
(a) The adjustment of the white fabric drive belt is very easily made tighter or looser by use of a socket wrench to turn the nut holding the idler pulley stud which is adjustable in the slot (see pictorial diagram). Pushing the stud upward tightens the belt, and downward loosens the tension of the belt. There is no necessity for making this belt real tight, as the belt is under no load -- only the dial disc -- it is advisable to just take out the slack.

(b) Adjustment of the rubber tread drum against the knurled drive shaft is accomplished by loosening the screws holding the variable condenser spacers (see pictorial diagram).
It is advisable to loosen and reset the fabric belt as mentioned above after making this adjustment, since the changing of one will affect the other.
The right tension between the drum and the knurled shaft can be easily determined by turning the condenser to one extreme rotation and adjusting the space just so it will pull the drive mechanism. Too much pressure will cause too much work between the rubber and shaft, resulting in slippage of the drive on slow speed. Too little pressure of course will result in slippage at any speed.

(c) For other drive adjustments, remove the Escutcheon Plate three screws on top, five along bottom -- to adjust the drive discs, if necessary.

12. NOTES:-
- (1) The replacement parts list is given on the last sheet of this manual.
 - (2) On some of the models the dial speed is accomplished by use of a push-pull knob instead of a double knob.
 - (3) The first terminal lug next to the ground terminal on the 11 terminal strip is not used.
 - (4) The resistance value of the resistor marked "X" on the pictorial diagram may be of different values, since it is placed there to reduce tendency of oscillations in the Third Short Wave Band.
 - (5) On one series of sets a single shielded wire is used to couple tuner to amplifier. The later sets use a double shielded wire. The red wire is the feed wire to the amplifier, and the black is ground and connects directly from the volume control to the ground lug within the power pack. This provides a better ground connection in addition to the shielding.
 - (6) Should the receiver blow fuses easily the 83V tube should be checked the first thing.

MODEL W
Parts List

HOWARD RADIO CO.

Part No.	Name	Ant. Per Unit	Price Ea.
2384	1/4 mfd. 200 volt Paper Condenser	4	.25
2758	1/4 mfd. 400 volt Paper Condenser	2	.25
2378	1/10 mfd. 200 volt Paper Condenser	8	.20
2756	1/10 mfd. 400 volt Paper Condenser	1	.20
2757	.05 mfd. 400 volt Paper Condenser	4	.20
1767	.01 mfd. 200 volt Paper Condenser	3	.20
2759	.03 mfd. 200 volt Paper Condenser	1	.20
2231	1 mfd. 200 volt Paper Condenser	1	.60
2232	1/2 mfd. 400 volt Paper Condenser	1	.60
2287	.002 Mica Condenser	1	.25
2381	.0001 Mica Condenser	2	.20
2419	.008 Mica Condenser	2	.35
1801	.001 Mica Condenser	1	.20
2422	.0005 Mica Condenser	3	.20
2763	500,000 Ohm 1/5 watt Resistor	3	.15
1897	200,000 Ohm 1/5 watt Resistor	5	.15
1844	100,000 Ohm 1/5 watt Resistor	2	.15
1873	100,000 Ohm 1/2 watt Resistor	3	.15
1843	50,000 Ohm 1/5 watt Resistor	3	.15
1747	50,000 Ohm 1/2 watt Resistor	2	.15
1772	20,000 Ohm 1 watt Resistor	1	.20
2274	4,000 Ohm 1/2 watt Resistor	1	.15
1956	4,000 Ohm 1/5 watt Resistor	1	.15
1835	3,000 Ohm 1/5 watt Resistor	1	.15
2383	3,000 Ohm 1/2 watt Resistor	1	.15
1829	1,800 Ohm 1/2 watt Resistor	1	.15
2373	1,100 Ohm 1/2 watt Resistor	1	.15
2774	500 Ohm 1/5 watt Resistor	1	.15
2206	500 Ohm 1/2 watt Resistor	2	.15
2761	300 Ohm 1/5 watt Resistor	1	.15
2871	Two Gang Variable	1	2.50
2806	Three Gang Variable	1	3.00

REPLACEMENT PARTS LIST OF POWER AMPLIFIER			
Part No.	Name	Ant. Per Unit	Price Ea.
2850	Power Transformer, 110 volt 60 cycle	1	\$ 7.50
2235	5 Amp. Fuse	1	.10
2859	"B" Voltage Divider	1	.70
2851	Filter Block 4 Section	1	7.00
2850	Filter Condenser 2 Section	1	2.00
2427	10 mfd. Electrolytic Condenser	1	.75
1926	Small "B" Choke	1	1.00
2858	Large "B" Choke	1	2.00
2758	1/4 mfd. Condenser 400 volt	5	.25
1827	50,000 Ohm 1/2 watt Resistor	4	.15
2423	25,000 Ohm 1/5 watt Resistor	1	.15
2758	2,000 Ohm 1/5 watt Resistor	1	.15
2339	3,500 Ohm 1/2 watt Resistor	1	.15
1897	200,000 Ohm 1/5 watt Resistor	1	.15
1844	100,000 Ohm 1/5 watt Resistor	1	.15
1843	50,000 Ohm 1/5 watt Resistor	2	.15
2980-C	Speaker Cone for the "Ortho"	1	1.00
2980-T	Speaker Transformer	1	2.00
2980-P	Speaker - 6 prong plug	1	.25

HUDSON-ROSS, INC.

MODEL 38
Schematic
MODEL 48
Schematic

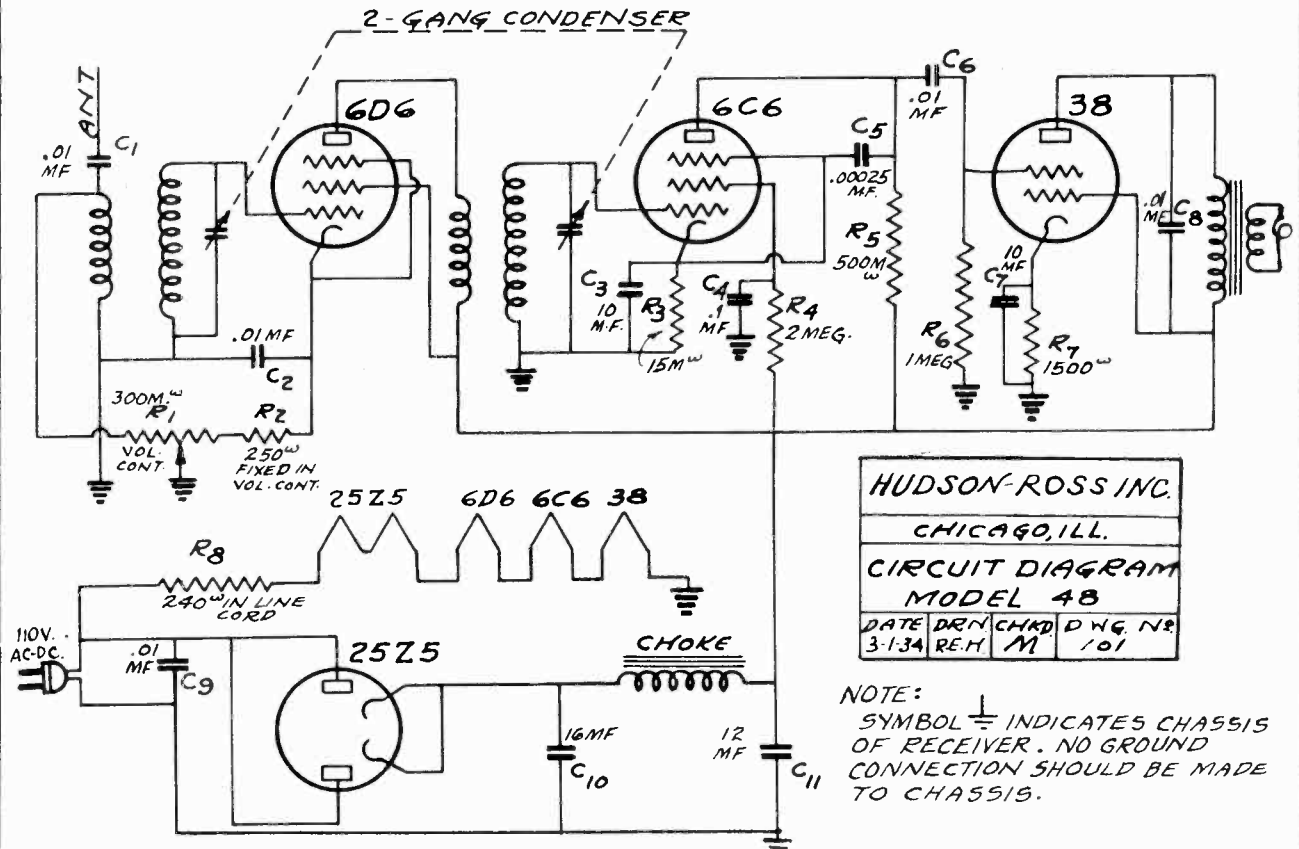

HUDSON-ROSS INC.
CHICAGO, ILL.
CIRCUIT DIAGRAM
MODEL 48
DATE DRN CHKD DWG. NO.
3-1-34 REH M 101

NOTE:
SYMBOL \perp INDICATES CHASSIS OF RECEIVER. NO GROUND CONNECTION SHOULD BE MADE TO CHASSIS.

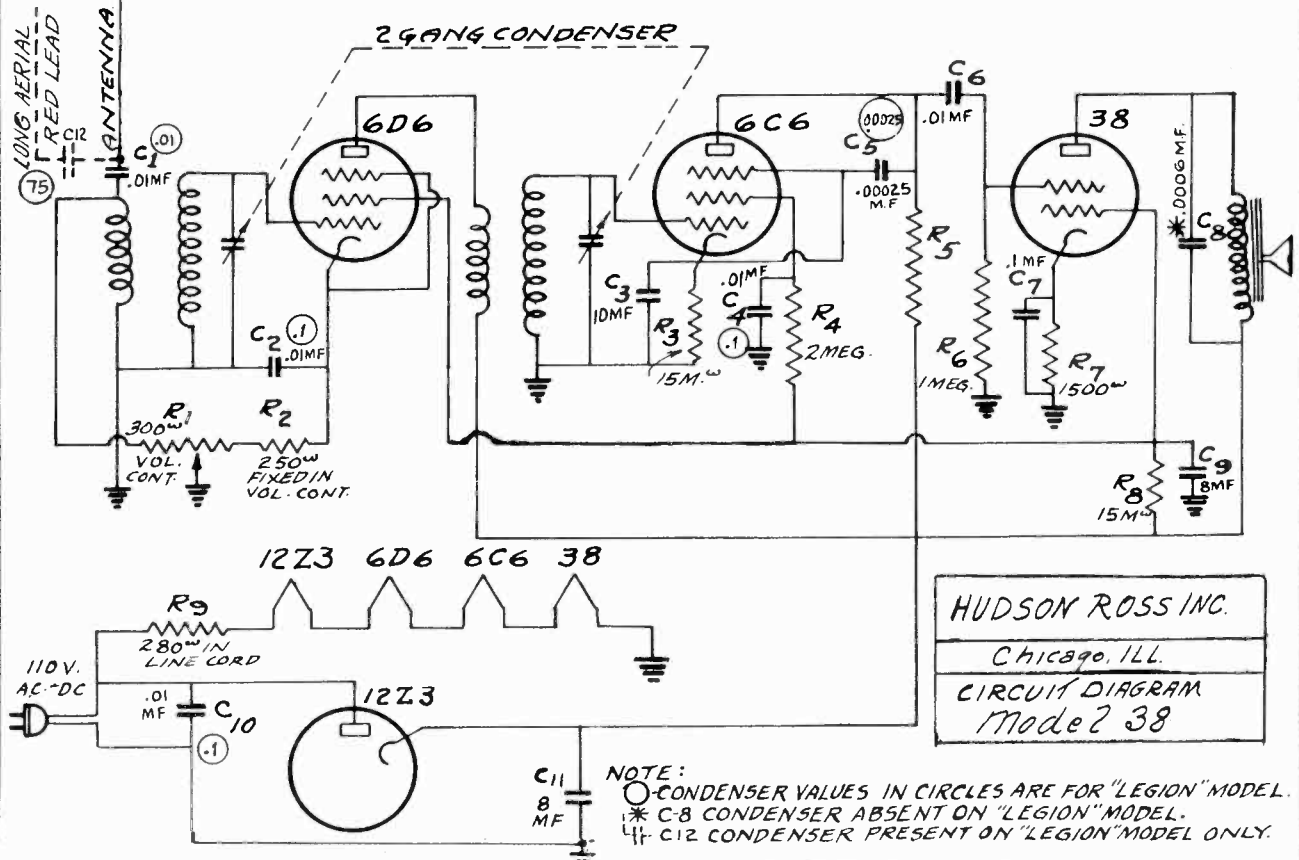

HUDSON ROSS INC.
Chicago, ILL.
CIRCUIT DIAGRAM
Model 238

NOTE:
○ CONDENSER VALUES IN CIRCLES ARE FOR "LEGION" MODEL.
* C-8 CONDENSER ABSENT ON "LEGION" MODEL.
⊥ C12 CONDENSER PRESENT ON "LEGION" MODEL ONLY.

MODEL 59
Schematic

HUDSON-ROSS, INC.

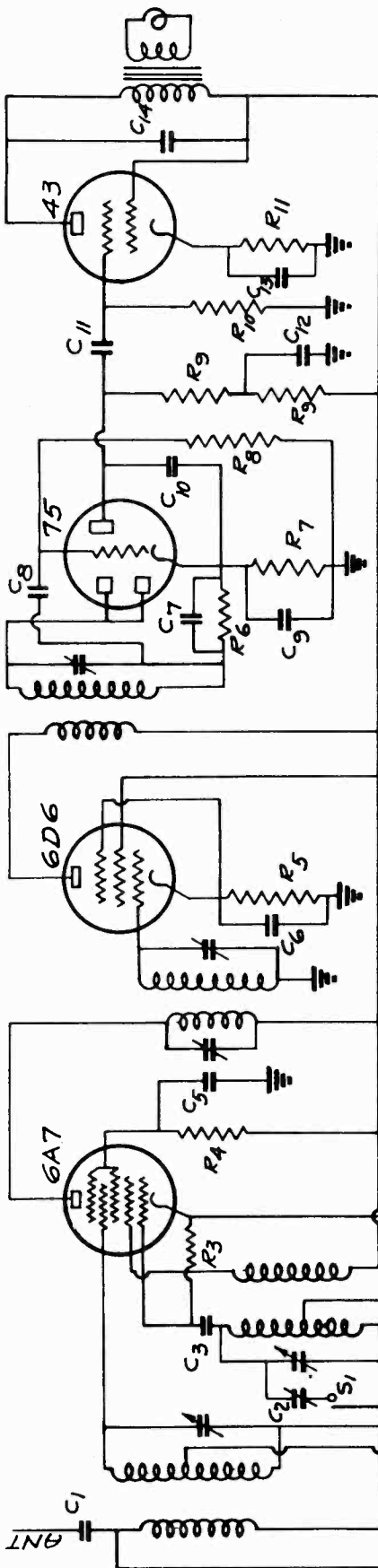

S1 AND S2 - COMBINATION SWITCH FOR BROADCAST AND SHORT WAVE.

- R1 - 10 M OHM VOLUME CONTROL
- R2 - 250 OHM CONTAINED IN VOL. CONTROL
- R3 - 250 M OHM RESISTOR
- R4 - 25 M
- R5 - 250 M
- R6 - 500 M
- R7 - 8 M
- R8 - 500 M
- R9 - 250 M
- R10 - 1 MEG.
- R11 - 600
- R12 - 150
- R13 - 20

- C1 00025 MFD. CONDENSER (PAD.)
- C2 - 75 MMFD.
- C3 -.00025 MFD.
- C4 -.01
- C5 .1
- C6 .1
- C7 -.00025
- C8 .1
- C9 10
- C10 -.0005
- C11 .1
- C12 .1
- C13 10
- C14 .006
- C15 .01
- C16 - 20
- C17 - 20

IF PEAK 456 KC.

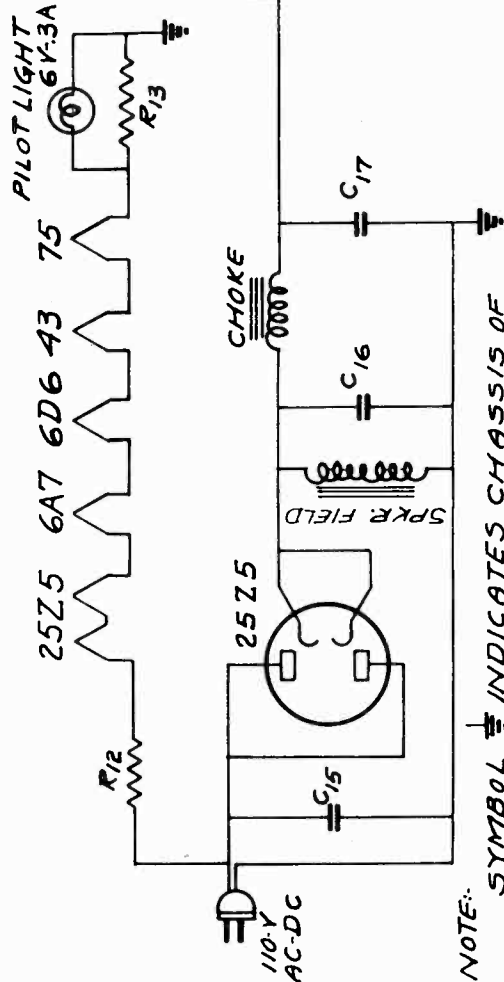

NOTE: SYMBOL INDICATES CHASSIS OF RECEIVER. NO GROUND CONNECTION SHOULD BE MADE TO CHASSIS.

HUDSON-ROSS, INC.

MODEL 69
Schematic

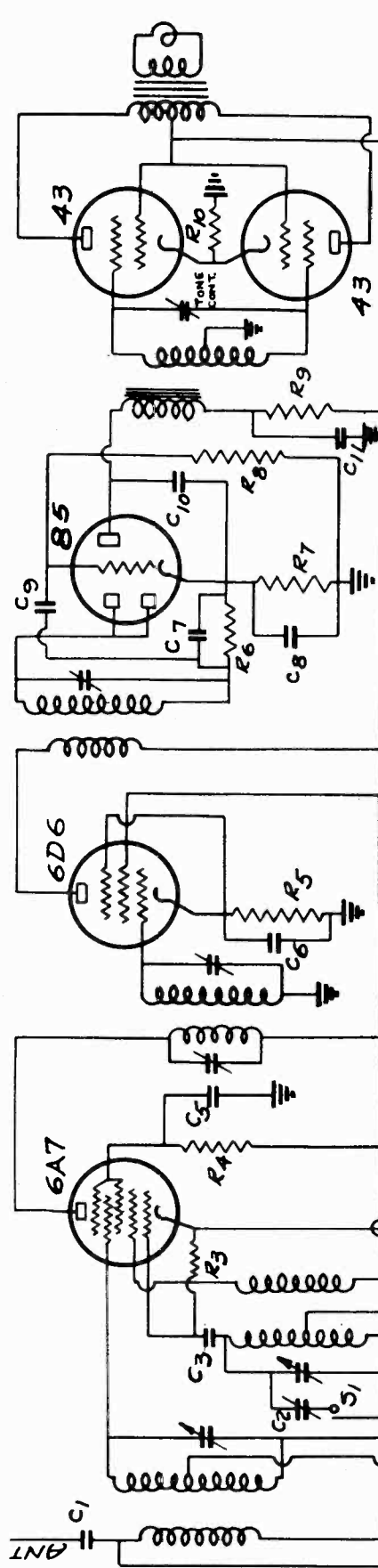

- S-1 AND S-2 COMBINATIONS SWITCH FOR BROADCAST AND SHORT WAVE.
- R1 - 10M OHM VOLUME CONTROL.
 R2 - 250 OHM CONTROL IN VOL. CONTROL.
 R3 - 250 M OHM RESISTOR
 R4 - 25 M " " " " " "
 R5 - 250 " " " " " "
 R6 - 500 M " " " " " "
 R7 - 1M " " " " " "
 R8 - 500 M " " " " " "
 R9 - 400 " " " " " "
 R10 - 60 OHM RESISTANCE IN LINE CORD.
 R11 - 20 OHM RESISTOR
 R12 - 20 OHM RESISTOR

- C1 - .00025MFD. CONDENSER (PAD)
 C2 - .75 MFD.
 C3 - .00025MFD
 C4 - .01 " " " "
 C5 - .1 " " " "
 C6 - .1 " " " "
 C7 - .00025 " " " "
 C8 - 10. " " " "
 C9 - .1 " " " "
 C10 - .0005 " " " "
 C11 - 3. (50V)
 C12 - .1 " " " "
 C13 - 20. " " " "
 C14 - 20. " " " "

IF PEAK 456 KC.

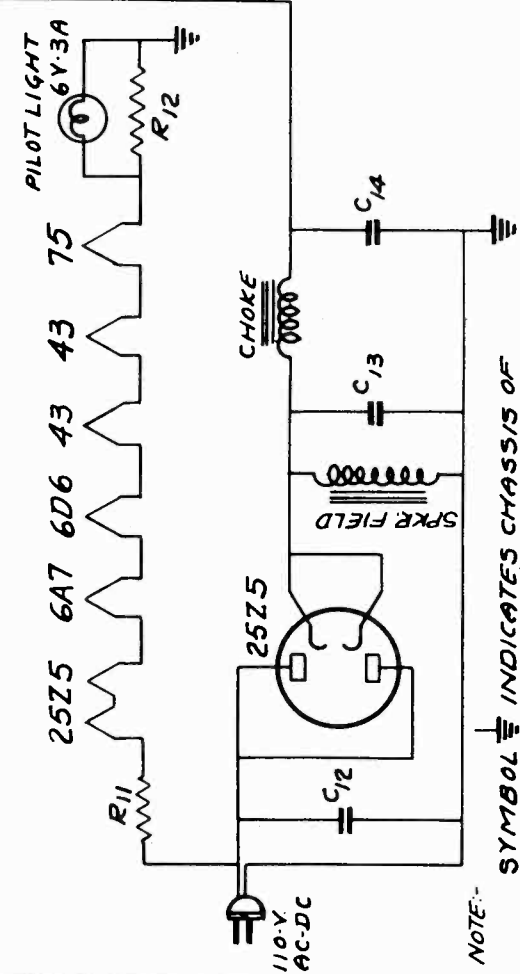

NOTE: SYMBOL \equiv INDICATES CHASSIS OF RECEIVER. NO GROUND CONNECTION SHOULD BE MADE TO CHASSIS.

HUDSON-ROSS INC.	
CHICAGO, ILL.	
CIRCUIT DIAGRAM	
MODEL 69	
DATE	PREPARED BY
3-23-34	REK. M
	102

MODEL 80
Schematic, Parts

HUDSON-ROSS, INC.

IF PEAK 456 KC.

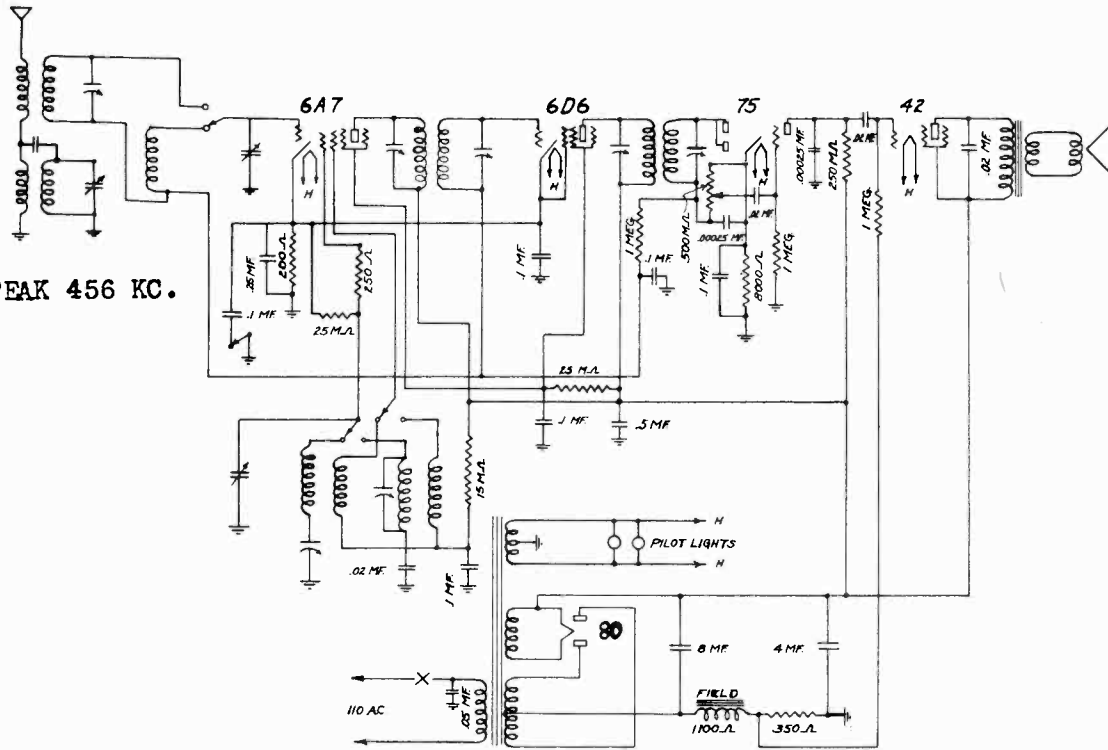

PART NO.

DESCRIPTION

PART NO.	DESCRIPTION
701	FILTER CONDENSER
702	.1 BY-PASS CONDENSER
703	.05 " "
704	.02 " "
705	.25 " "
706	.5 " "
707	.00025 " "
708	1-WATT RESISTOR
709	MISCELLANEOUS RESISTORS(SPECIFY VALUES)
717	350 OHM POWER RESISTOR
718	VOLUME CONTROL
719	SHORT WAVE AND BROADCAST SWITCH
720	OSCILLATOR COIL 456 KC
723	CORD AND PLUG
733	POWER TRANSFORMER
738	3-GANG CONDENSER
739	1ST I F TRANSFORMER
740	2ND I F TRANSFORMER
741	PRE SELECTOR COIL
745	PILOT LAMP
749	TRIMMER
751	KNOB (LARGE)
751-A	KNOBS
754	PILOT LIGHT SOCKET
758	SPEAKER
758-A	SPIDER AND VOICE COIL
758-B	6" DIAPHRAM
762	S.W. OSCILLATOR COIL
763	ANTENNA S.W. OSCILLATOR COIL
767	DIAL DRIVE DISC
768	CELLULOID DRIVE DISC
769	DIAL FACE
777	DIAL POINTER
779	CONVEX DIAL CRYSTAL

INSULINE CORP. OF AMERICA

MODEL "Trans-Atlantic"
Schematic, Socket

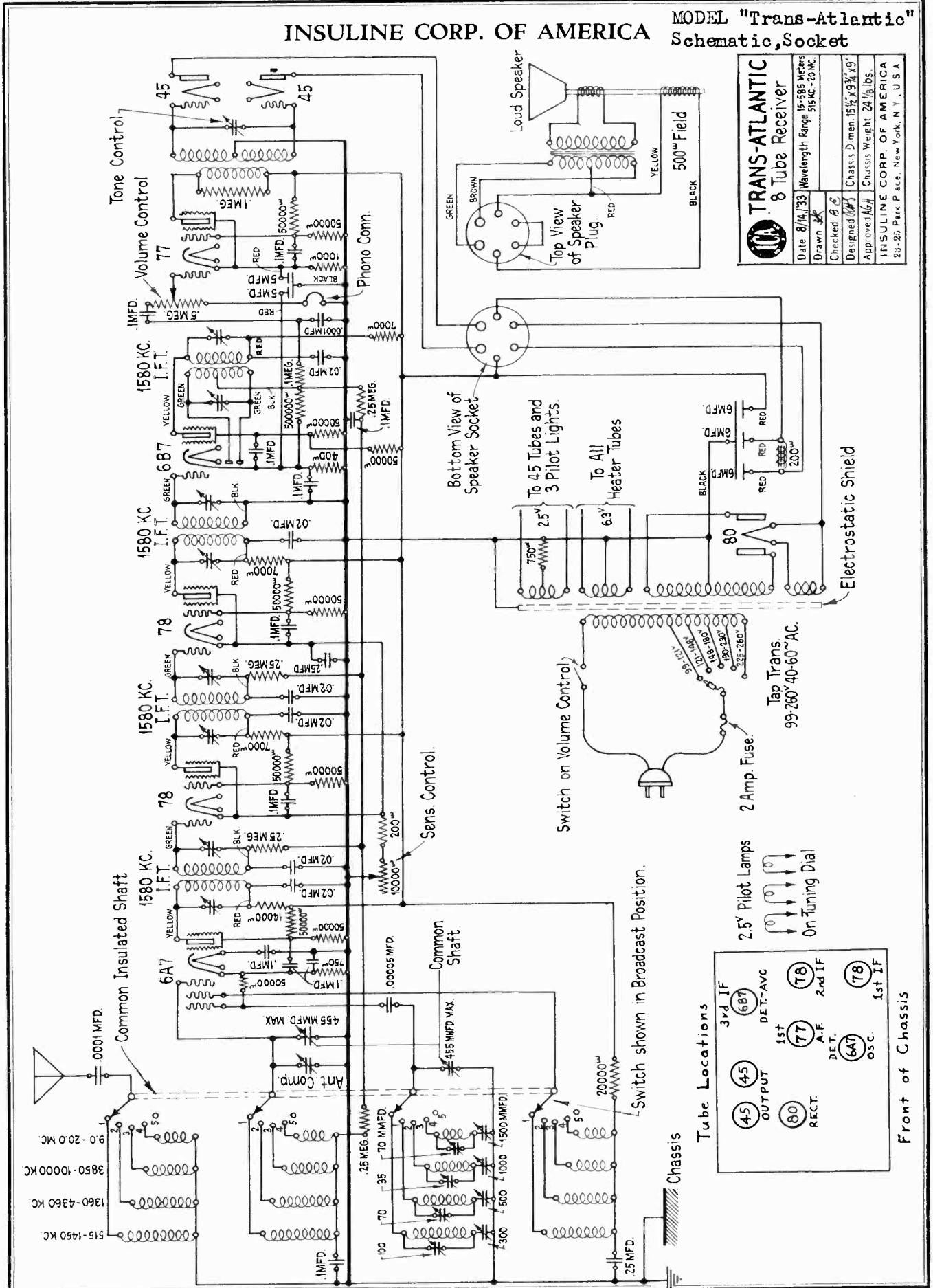

	TRANS-ATLANTIC	15-585 Meters
	8 Tube Receiver	Wavelength Range 515 AC-20 MC.
Date 8/14/33	Drawn JK	Checked BS
Designed WJ	Approved WJ	Approved WJ
Chassis Dimension: 15 1/2 x 9 3/4 x 9"		Chassis Weight: 2 1/2 lbs.
INSULINE CORP. OF AMERICA 83-25 Park P. ave., New York, N. Y., U. S. A.		

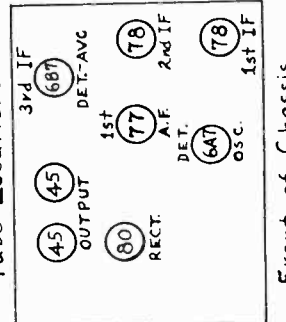

MODEL "Trans-Pacific" INSULINE CORP. OF AMERICA
Schematic, Socket

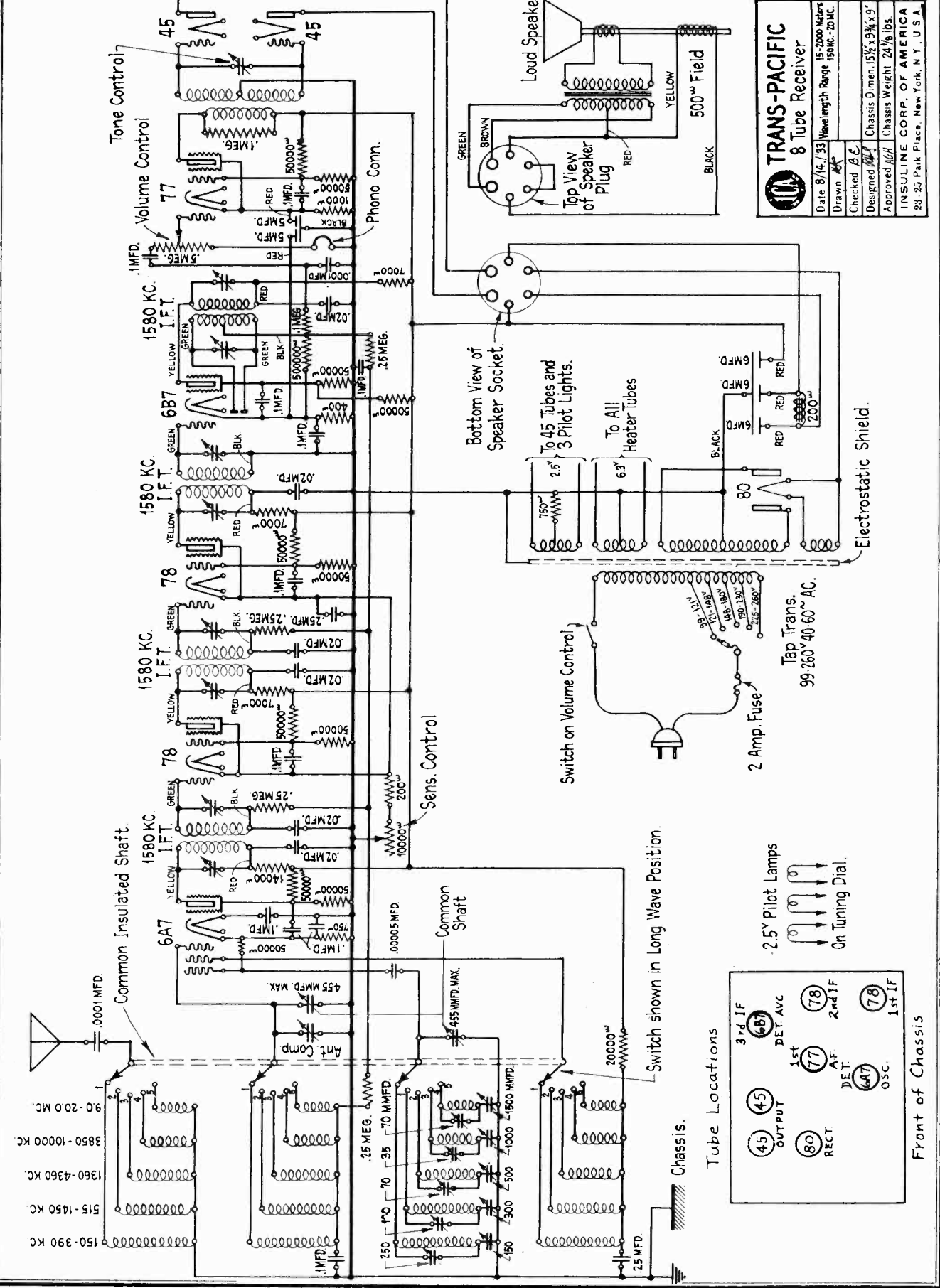

TRANS-PACIFIC	
8 Tube Receiver	
Date B/14/33	Wave length Range 15-2000 Meters
Drawn AK	150 MC - 20 MC
Checked BC	
Designed 6/3	Chassis Dimen. 15 1/2" x 9 3/4" x 9"
Approved 6/4	Chassis Weight 24 1/2 lbs.
INSULINE CORP. OF AMERICA	
28-29 Park Place, New York, N.Y., U.S.A.	

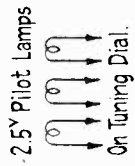
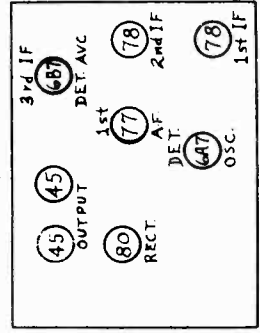

Switch shown in Long Wave Position.

Chassis.

INSULINE CORP. OF AMERICA

MODEL "Icasix"
(2 Band)
Schematic, Socket

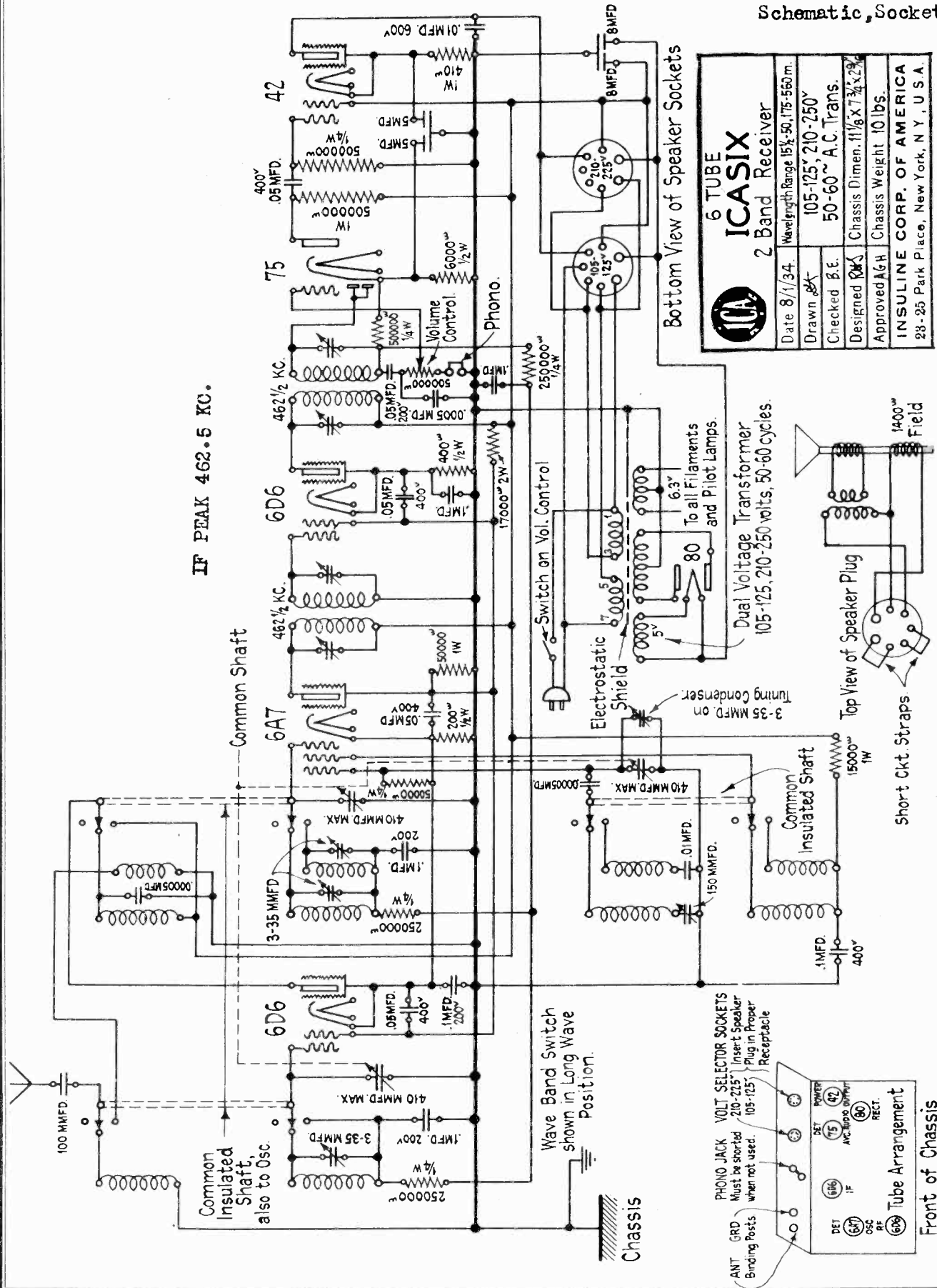

IF PEAK 462.5 KC.

Bottom View of Speaker Sockets

6 TUBE ICASIX 2 Band Receiver	
Date 8/1/34.	Wave length Range 15 $\frac{1}{2}$ -50, 175-550 m.
Drawn <i>AK</i>	105-125, 210-250 ν
Checked B.E.	50-60 ν A.C. Trans.
Designed <i>WKS</i>	Chassis Dimen. 11 $\frac{1}{8}$ " x 7 $\frac{3}{4}$ " x 2 $\frac{1}{2}$ "
Approved <i>AGH</i>	Chassis Weight 10 lbs.
INSULINE CORP. OF AMERICA 23-25 Park Place, New York, N. Y., U. S. A.	

Dual Voltage Transformer
105-125, 210-250 volts, 50-60 cycles.

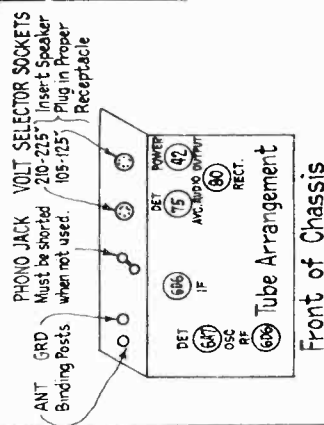
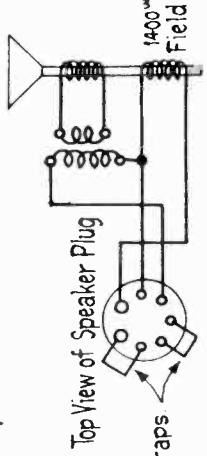

INSULINE CORP. OF AMERICA

MODEL "Elite"
Schematic

	ELITE
Date 4/16/34	Wavelength Range 15-550m.
Drawn K	AC. DC. 108-250
Checked KH	VOLTS 25-60
Designed JH	Chassis Dimen. ---
Approved JH	Chassis Weight ---
INSULINE CORP. OF AMERICA 23-25 Park Place, New York, N.Y., U.S.A.	

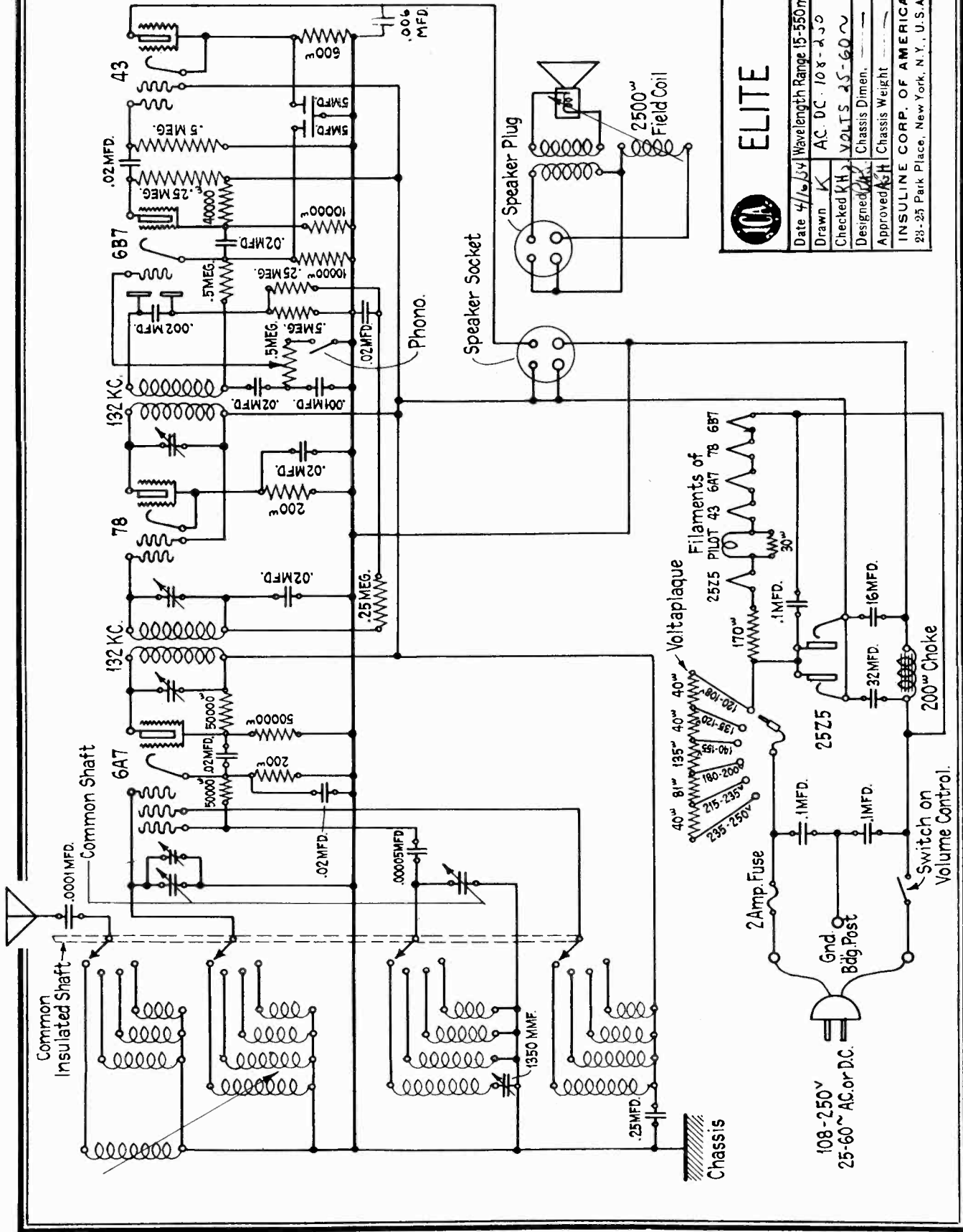

MODEL "Classic"
Schematic

INSULINE CORP. OF AMERICA

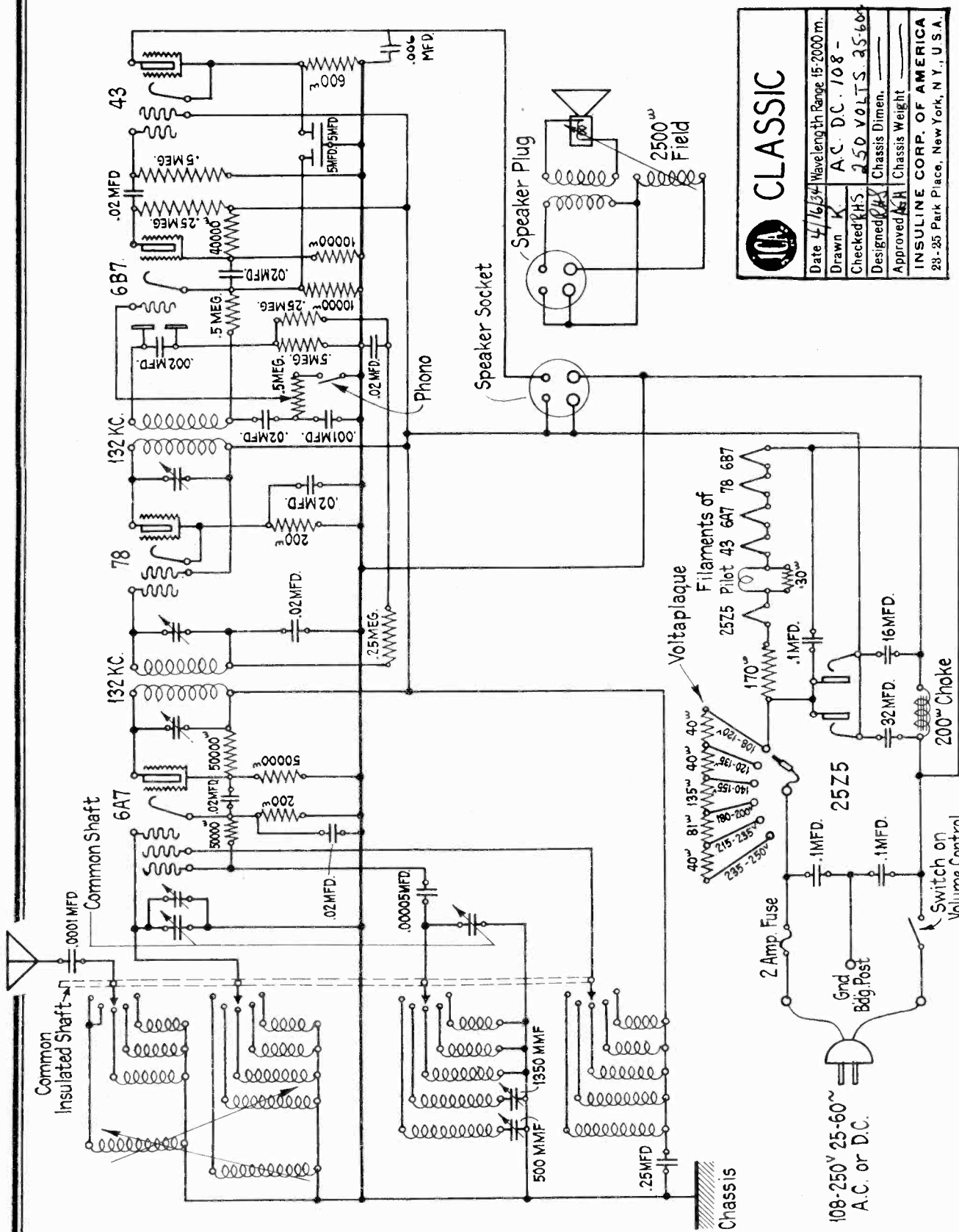

CLASSIC	Date <u>4/16/34</u> Wavelength Range <u>15-2000 m.</u>
	Drawn <u>K</u> A.C. D.C. <u>108-</u>
	Checked <u>PHS</u> <u>250 VOLTS 3560</u>
	Designed <u>PH</u> Chassis Dimen. <u> </u>
	Approved <u>PH</u> Chassis Weight <u> </u>
INSULINE CORP. OF AMERICA 28-25 Park Place, New York, N.Y., U.S.A.	

MODEL K-60 (K-6)
(St. Regis)
Voltage, Alignment

INTERNATIONAL RADIO CORP.

TO REPLACE DIAL LIGHT

Dial light socket assembly may be pried out from the rear of control head by using a small screw driver or knife blade.

AVERAGE TUBE VOLTAGES:

Measurements made from indicated points to chassis. Battery voltage 6 volts.

POSITION	TUBE	E _f	E _k	E _{g₁}	E _{g₂}	E _{g₃}	E _p
R. F. Amplifier	6D6	5.6	2	*	2	75	185
1st Det.-Osc.	6F7	5.6	3	Det. * Osc. —1	3	75	Det. 185 Osc. 75
I.F. Amplifier	6D6	5.6	2	*	2	75	185
2nd Det.-A.V.C.	75	5.6	2	0	0	—	75
Power Amp.	42	5.6	15	0	—	185	175
Rectifier	84	5.6	185	—	—	—	—

f—Filament; k—Cathode; g₁—Control Grid; g₂—Suppressor Grid; g₃—Screen Grid; p—Plate; *—Depends on applied signal strength.

Balancing and Aligning

Each automobile radio is carefully balanced on accurate oscillators before leaving the factory. If it is necessary to rebalance because of part changes or other causes a good test oscillator capable of delivering modulated signals at 262½, 1500 and 600 Kc. will be needed. The customary audio out-put meter may be used IF the out-put of the test oscillator is weak enough to get below the A.V.C. action. Otherwise a microammeter will be needed to measure the A.V.C. voltage developed. It should be connected from ground to the junction of two 100M resistors and one condenser in the center bottom of the chassis.

To balance the I.F. circuits, attach the antenna wire to the test oscillator. Short out the oscillator section of the tuning condenser in the radio by inserting a thin piece of metal between the plates. Set the test oscillator to 262½ Kc. and adjust the trimmers on the I.F. transformers for maximum output. Go over all four adjustments at least twice for accuracy.

Next set the test oscillator at 1500 Kc. and open the tuning condenser until it is tuned to the test signal as indicated by maximum output. Adjust the small trimmers on top of the condenser gang for maximum output.

Set the test oscillator at 600 Kc. and, while rocking the tuning condenser slowly back and forth across this setting, adjust the paddler condenser for maximum output. Go over the adjustments at least twice for accuracy.

INTERNATIONAL RADIO CORP.

MODEL CB (Battery)
Schematic
MODEL CMS
Schematic

MODEL "CMS" - BROADCAST & SHORT WAVE

INTERNATIONAL RADIO CORP.
ANN ARBOR-MICH.

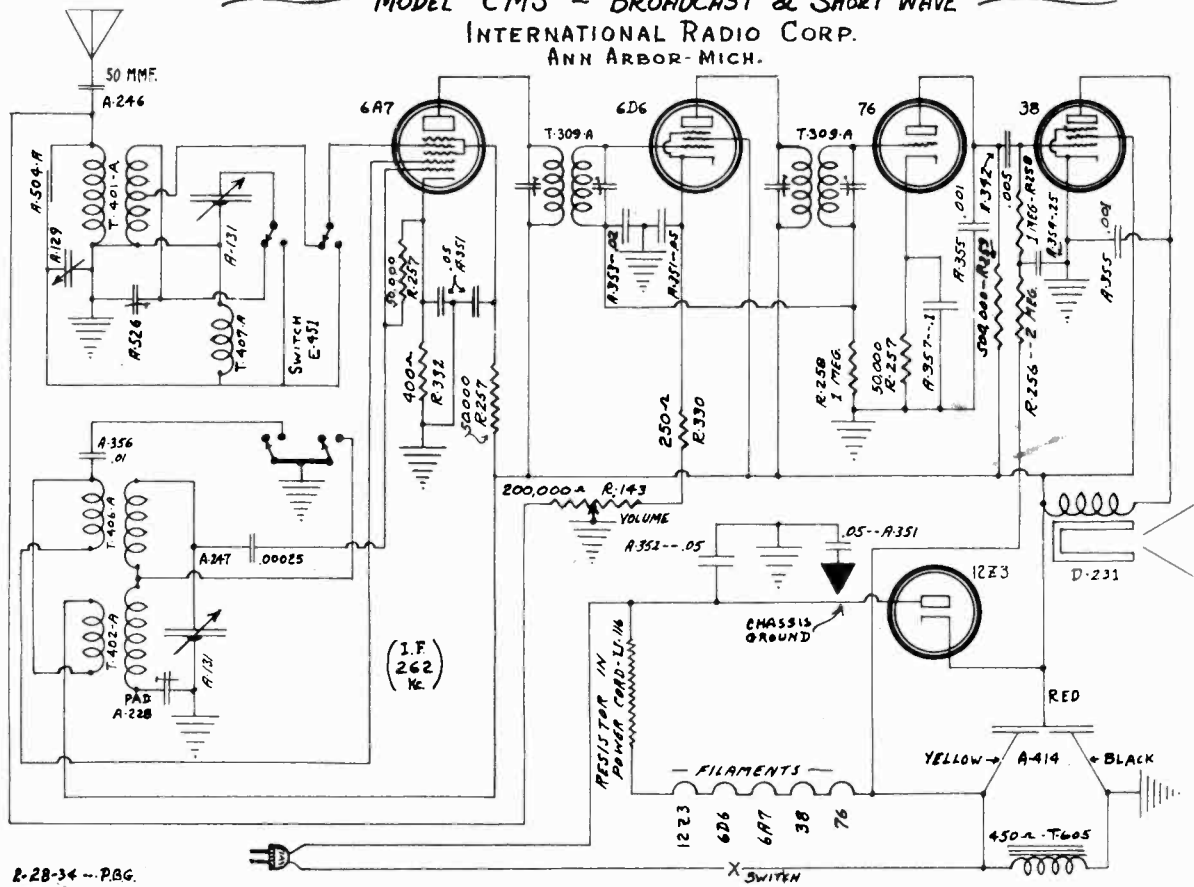

R-28-34 -- P.B.G.

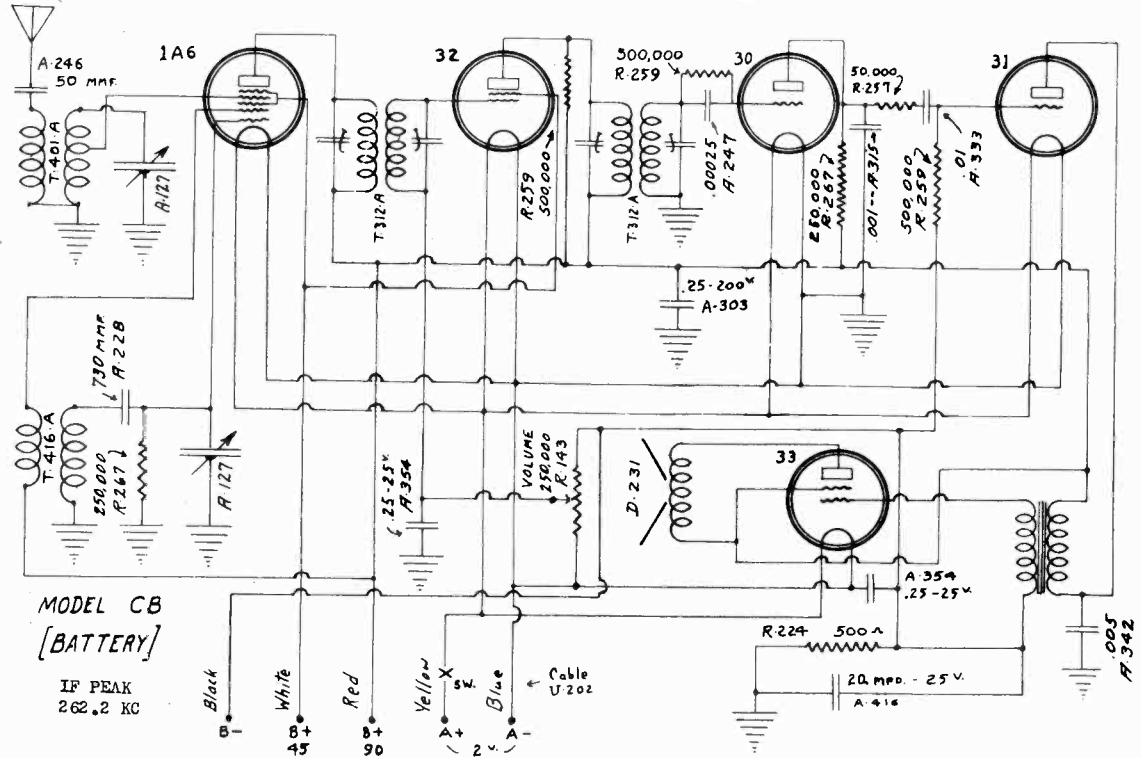

MODEL CB
[BATTERY]

IF PEAK
262.2 KC

Black 45
White 90
Red 90
Yellow 2
Blue 2
Cable U-202

MODEL CM
Schematic, Voltage

INTERNATIONAL RADIO CORP.

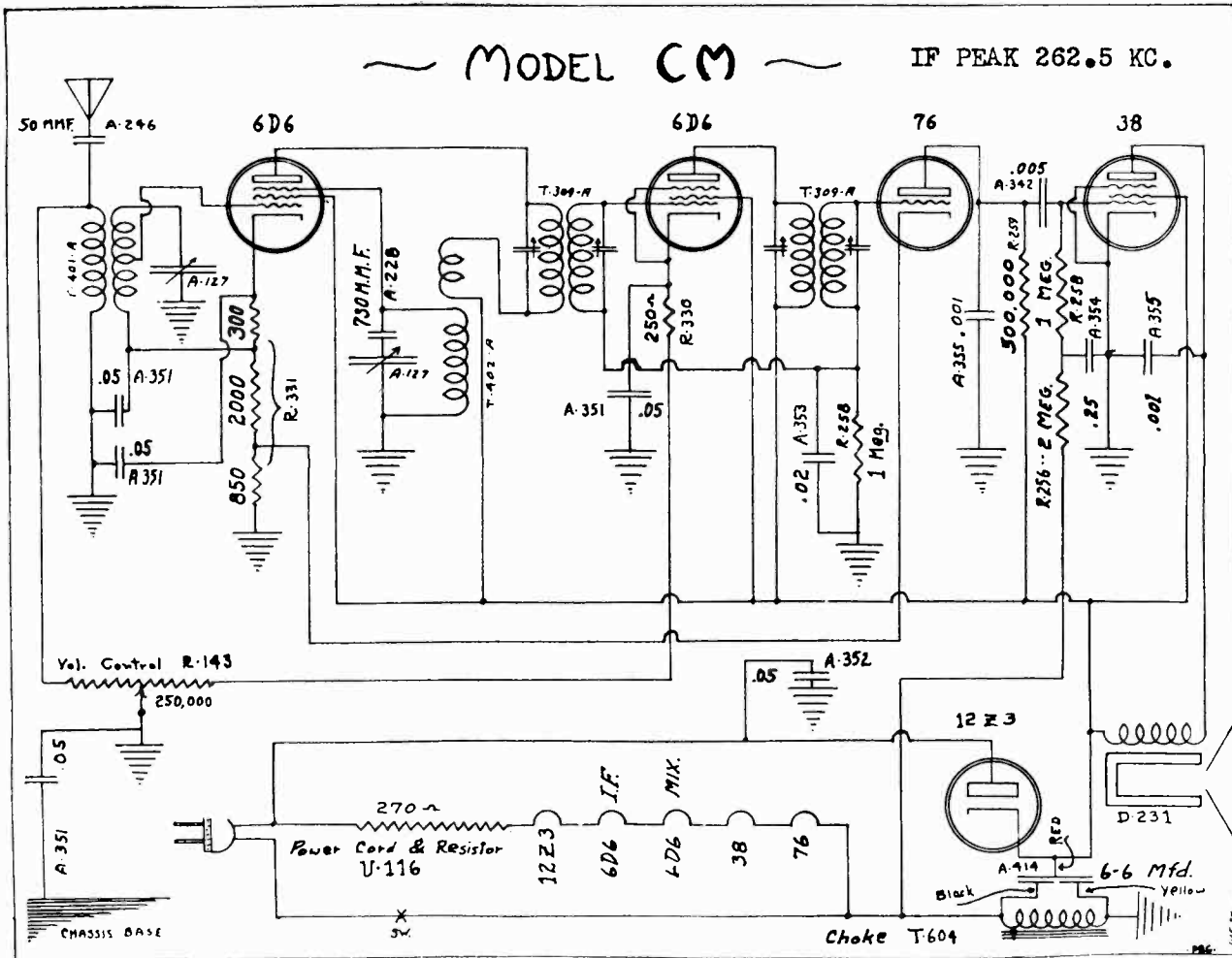

For Balancing Data, Alignment Data

See Index

CHASSIS CM

To adjust IF units and align condensers follow these operations in the order given using an output meter connected across the speaker—Operations 1 (oscillator section of 2 gang condenser nearest rear of chassis), 2, 3 and 4.

Color Code Marking of Coils

- 1st IF—Red
- 2nd IF—Red
- Antenna—Red
- Oscillator—Red

Socket Voltages

Approximately normal tube voltages measured with a 0-300 volt, 1000 ohm per volt DC voltmeter with set operated on a 115 volt AC line. Volume control in FULL ON position. Measurements made from B negative (condenser frame) to socket prongs.

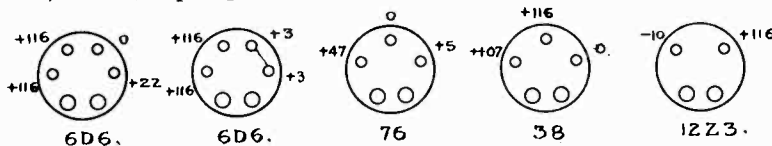

CHASSIS CM.
BOTTOM VIEW.

INTERNATIONAL RADIO CORP. MODEL A-7, BW, CD (DAC) Schematic, Voltage

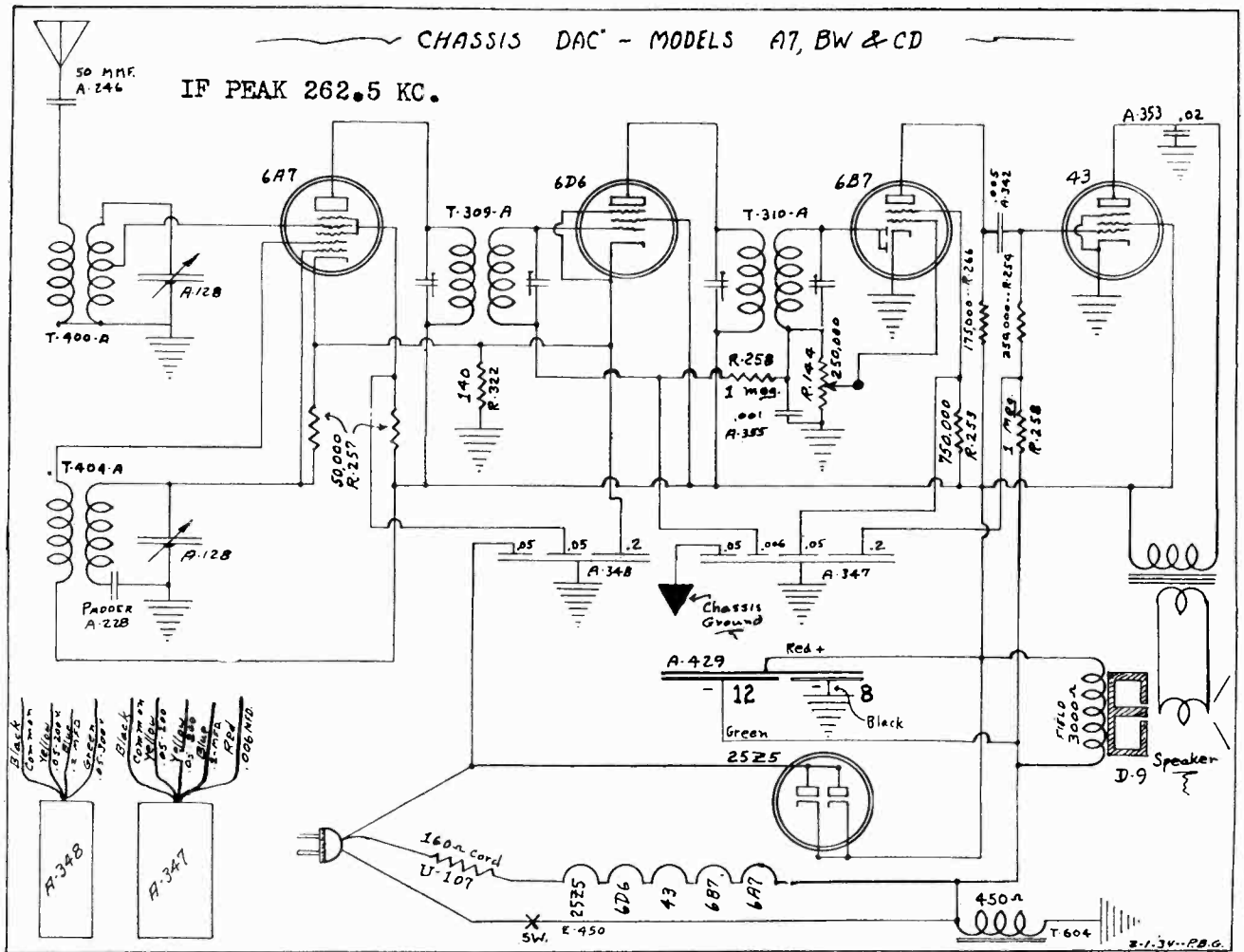

For Balancing Data, Alignment Data

see Index

CHASSIS DAC

To adjust units and align condensers follow these operations in the order given using microammeter or D. C. milliammeter connected as previously described—Operations 1 (oscillator section of 2 gang condenser nearest front of chassis), 2, 3, and 4.

Color Code Marking of Coils

1st IF—Red
Antenna—Green

2nd IF—Green
Oscillator—Yellow

Socket Voltages

Approximate normal tube voltages measured with a 0-300 volt, 1000 ohm per volt DC voltmeter with set operated on a 115 volt AC line. Volume control in FULL ON position. Measurements made from B negative (condenser frame) to socket prongs.

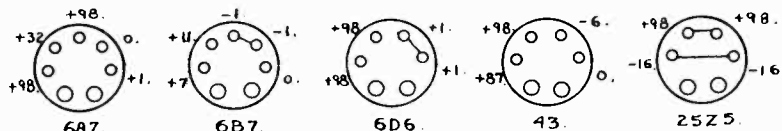

CHASSIS DAC.
BOTTOM VIEW.

MODEL A-8, A-9, A-10,
AD-11, AD-12
(Chassis DAS)

INTERNATIONAL RADIO CORP.

Schematic, Voltage

CHASSIS "DAS" - MODELS A8-9-10

IF PEAK 262.5 KC.

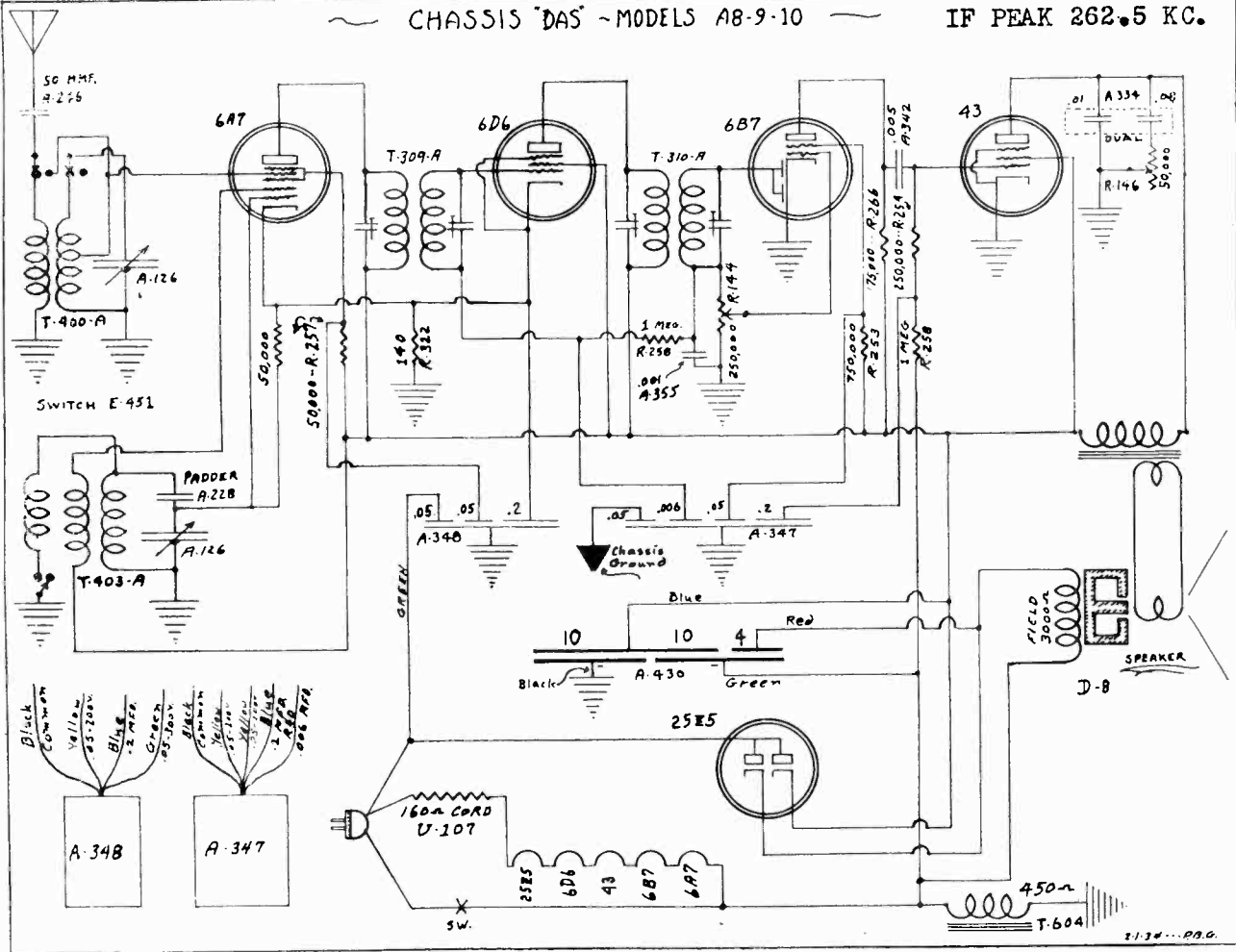

CHASSIS DAS

For
Balancing and
Alignment
Data, see
Index

To adjust IF units and align condensers follow these operations in the order given using microammeter or D. C. milliammeter as previously described—Operations 1 (oscillator section of 2 gang condenser nearest front of chassis), 2, 3, and 4.

Aligning Short Wave on DAS Chassis

When properly adjusted for the broadcast band No Additional Adjustments Are Necessary on the Short Wave Band.

Color Code Marking of Coils

- 1st IF—Red
- 2nd IF—Green
- Antenna—Green
- Oscillator—No mark

Approximate normal tube voltages measured with a 0-300 volt, 1000 ohm per volt DC voltmeter with set operated on a 115 volt AC line. Volume control in FULL ON position. Measurements made from B negative (condenser frame) to socket prongs.

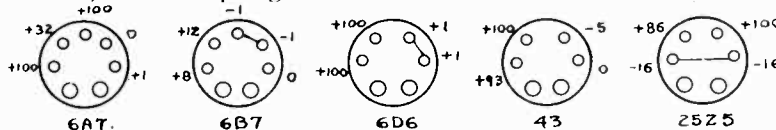

CHASSIS DAS.
BOTTOM VIEW.

INTERNATIONAL RADIO CORP.

MODEL DA-8, DA-9, DA-10
D-11, D-12, D-14
(Chassis D.DSP)
Schematic, Voltage

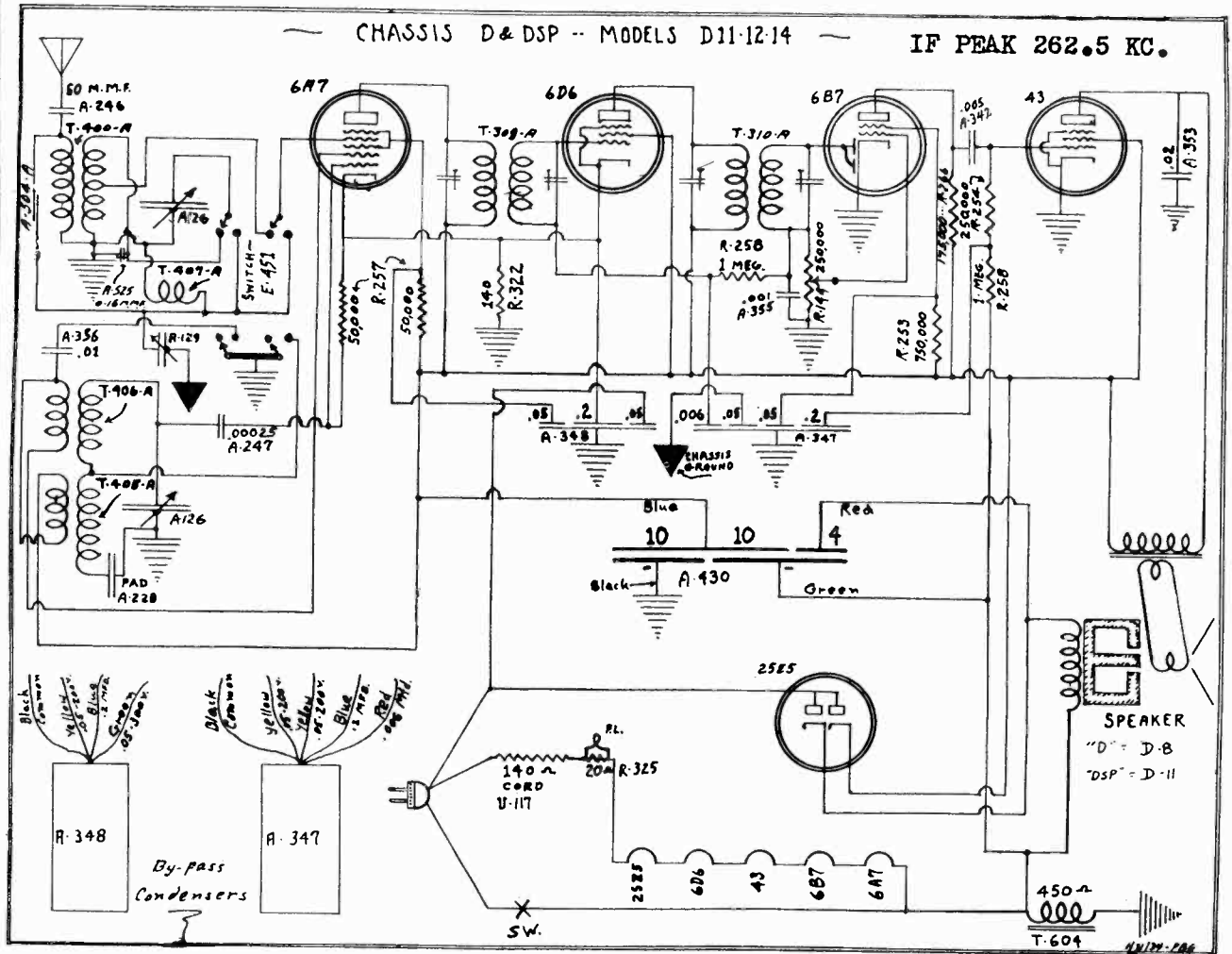

For Balancing Data, Alignment Data

see Index

Color Code Marking of Coils

- | | |
|------------------|---------------------|
| 1st IF—Red | 2nd IF—Green |
| BC Antenna—Green | BC Oscillator—Green |
| SW Antenna—Green | SW Oscillator—Green |

Socket Voltages

Approximate normal tube voltages measured with a 0-300 volt, 1000 ohm per volt DC voltmeter with set operated on a 115 volt AC line. Volume control in FULL ON position. Measurements made from B negative (condenser frame) to socket prongs.

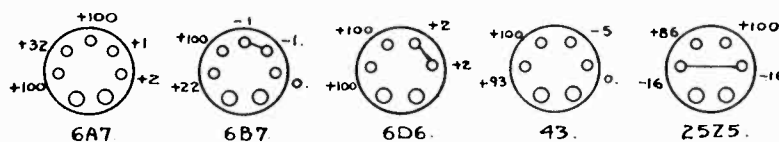

CHASSIS D. & DSP.
BOTTOM VIEW.

MODEL ES-19, ES-20
Chassis ES
Schematic
Alignment Data

INTERNATIONAL RADIO CORP.

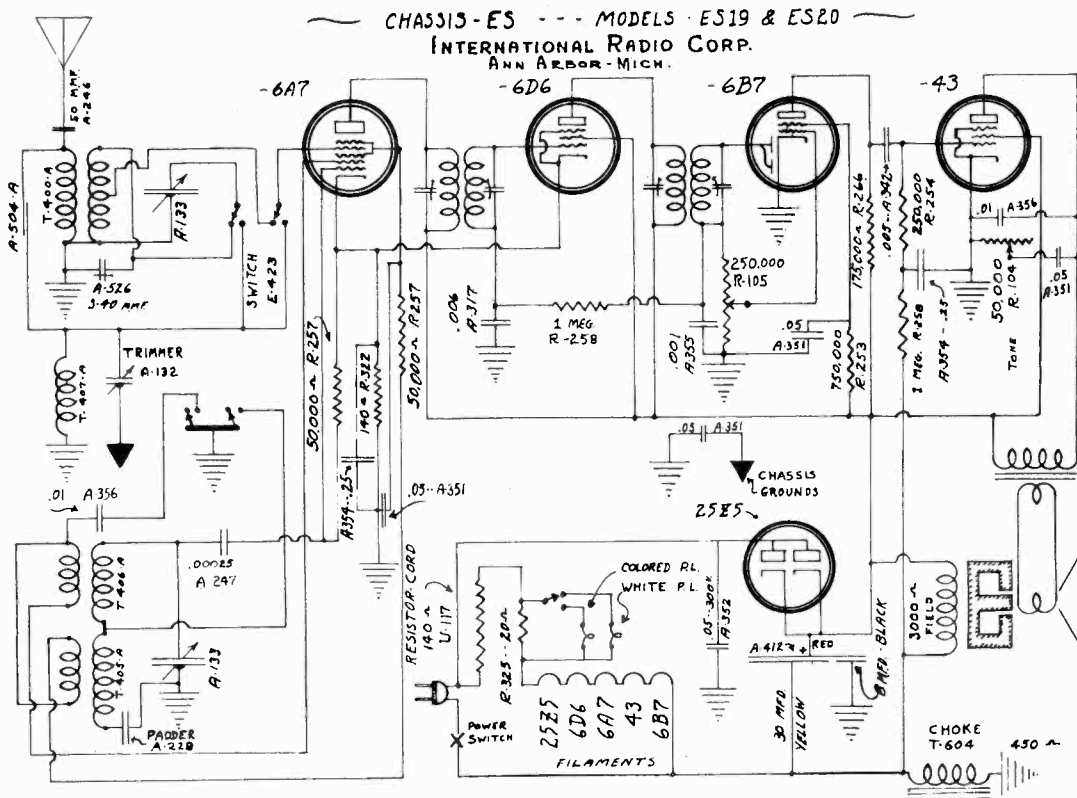

324-34--PBA

Instructions for Balancing and Aligning

Adjustments have been carefully made at the factory and should not need to be changed unless it has been necessary to replace an IF transformer or coil or the adjustments have been tampered with. Later in this bulletin, when the different chassis are taken up one by one, reference will be made to the following operations.

OPERATION No. 1 Adjustment of IF transformers. When adjusting the IF units the oscillator section of the 2 gang variable condenser must be shorted out. This is easily accomplished by inserting a thin strip of metal between the plates. Set the test oscillator to 262½ kilocycles and connect its output to the antenna wire of the set. Using a No. 4 fibre spintite socket wrench adjust the 4 nuts at the ends of the IF units until exact resonance is obtained. It is advisable to go over them more than once as when one nut is adjusted it may throw the adjustment on the other end of the unit, slightly out of resonance.

OPERATION No. 2. Adjusting trimmers on 2 gang condenser at 1500 kilocycles. Set the test oscillator to 1500 kilocycles and connect its output to the antenna wire of the set. If the output of the oscillator is too strong connect through a very small fixed condenser or place the output wire of the oscillator near the antenna wire without making any direct connection. Open the variable condenser until maximum signal is indicated by the meter. Then adjust the trimmer on the antenna section of the condenser until maximum signal is indicated on the meter. See "Recommended Service Department Equipment" for instructions regarding meter.

OPERATION No. 3. Aligning 2 gang condenser on 1000 kilocycles. Test oscillator set at 1000 kilocycles and coupled to antenna wire of set. Insert a thin bakelite, celluloid or mica feeler strip between the plates of the variable condensers to determine whether the circuits are properly matched. The action is this—the dielectric constant of the celluloid feeler strip being higher than that of the air it displaces, results in an increase of capacity. Open the variable condenser just enough to indicate two or three points below maximum signal. As the feeler is inserted the meter reading should indicate increasing signal and then decreasing as the feeler is inserted farther. This procedure should be followed on both sections. Should the meter fail to show an increase in signal as the strip is inserted in either section this indicates too great a capacity for that section. This may be corrected by bending the outside rotor plates out at the point where they begin to mesh with the stator.

OPERATION No. 4 Aligning 2 gang condenser at 550 kilocycles. Instructions same as for operation 3 except test oscillator and set tuned at 550 kilocycles.

CHASSIS' D & DSP

Chassis DSP is the same as chassis D except that an external 6" dynamic type speaker is used.

To adjust IF units and align condensers follow these operations in the order given—Operations 1 (oscillator section of 2 gang condenser nearest front of chassis), 5 (given below), 6 (given below), 3, 4 and 7 (given below). Use microammeter or DC milliammeter as previously described.

OPERATION No. 5 Be sure the switch on the rear of the chassis is turned to the short wave position. Remove short from the oscillator section of the 2 gang condenser and proceed as follows. Turn the small two plate vernier condenser so that it is only about 1/5 meshed. If the test oscillator is to be coupled direct to the antenna wire it should be attached close to the chassis. The coiled up antenna wire acts as an RF choke and high frequency signals will not go through it. A pin pushed through the insulation of the antenna wire will allow connection close to the chassis. Set the test oscillator so that it is radiating a signal on approximately 22 meters and rotate the condenser gang very slowly until this signal is picked up. Alternately change the setting of the trimmer on the oscillator section of the 2 gang and retune the 2 gang until the maximum signal is indicated.

OPERATION No. 6 Turn the switch on the rear of the chassis to the broadcast position. Tune in the 1500 kilocycle signal from the broadcast test oscillator. It will have been noted that there is no trimmer in the customary location on the antenna section of the 2-gang condenser. The trimmer is mounted externally near the 2 plate vernier condenser. This trimmer is used only on the broadcast band, the 2-plate vernier being in the circuit on the short wave position. Adjust the broadcast antenna trimmer for maximum signal.

OPERATION No. 7. Turn the switch on the rear of the chassis to the short wave position. Set the two plate vernier condenser so that it is about 4/5 meshed. Pick up the 45 meter signal from the short wave test oscillator. Test for resonance with the feeler strip as described in operation 3 but do not bend any plates. If the antenna section of the condenser gang has insufficient capacity it will be necessary to crowd together two or three turns of wire on the short wave antenna coil. If too much capacity, they must be spread somewhat. The short wave antenna coil is the space wound coil on the bottom of the chassis.

MODEL 520, 521
Chassis 2035
Schematic

INTEROCEAN RADIO CORP.

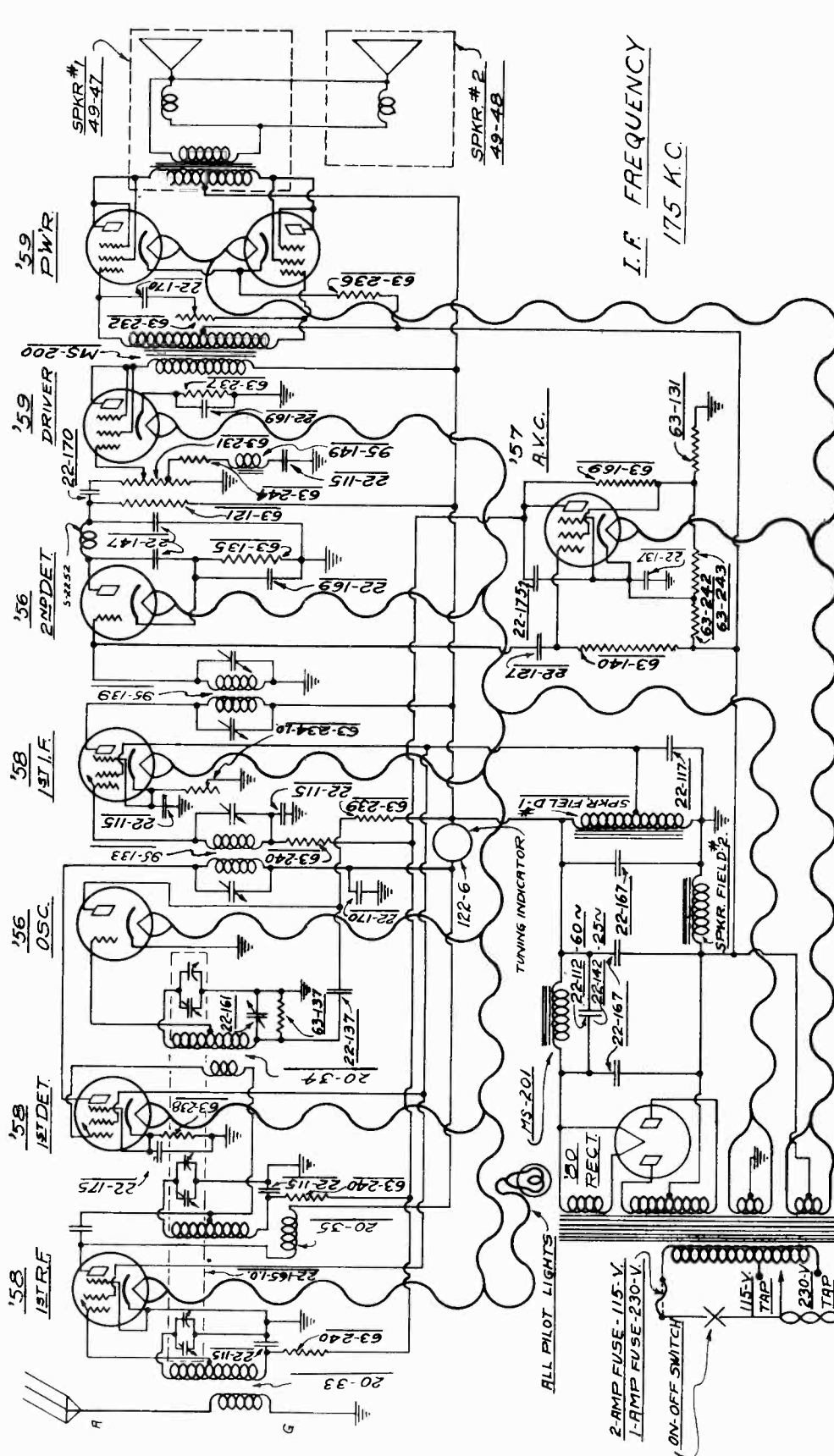

I.F. FREQUENCY
175 K.C.

INTEROCEAN RADIO CORP.
CHICAGO, ILL.
10-TUBE SUPERHETERODYNE
MODELS 520 521
CHASSIS 2035

95-144 25-30 CYCLE
95-195 50-60 CYCLE

TO 115 OR 230 VOLT A.C.

MODEL 520, 521
Voltage, Socket
Parts List

INTEROCEAN RADIO CORP.

PARTS AND PRICES
MODELS 520 521
CHASSIS NO. 2035

11-3	Dial Pulley String.....	per ft.	\$.25
26-38	Calibrated Dial Strip.....		.15
80-69	Dial Cord Tension Spring.....		.01
80-85	Volume and Tone Control Dial Tension Spring.....		.10
85-274	Volume Control Dial Strip.....		.10
83-275	Tone Control Dial Strip.....		.12
100-18	2.5 Volt Pilot Lamp.....		2.00
122-6	Shadowgraph Meter.....		
Condensers			
22-112	.1 mfd 300 Volt (Filter).....		.25
22-115	.1 " 200 " (5 used, see footnote).....		.35
22-117	.5 " 300 " (Filter).....		.50
22-137	.06 " 400 " (Oscillator Plate).....		.25
22-142	.4 " 300 " (Filter, 25 Cycle Only).....		.40
22-147	.0005 500 " (2nd Detector Plate).....		.20
22-161	Padder.....		.45
22-165	Three Gang Variable.....		3.50
22-167	8. mfd 500 Volt (Filter).....		1.50
22-169	8. " 50 " (2nd Detector Cathode, Driver Cathode, and 1st Audio Cathode).....		.55
22-170	.1 " 400 " (1st Detector Plate, Audio Coupling and Tone Control).....		.25
Resistors			
65-121	100K Ohm 1 Watt (2nd Detector Plate).....		.25
65-135	50M " 1 " (2nd Detector Cathode).....		.25
63-137	250M " 1 " (Oscillator Grid).....		.25
63-140	1 Meg " 1 " (A. V. C. Grid).....		.25
63-169	400 " 1 " (A. V. C. Plate).....		.25
63-231	Volume Control Assembly.....		1.25
63-232	Tone Control Assembly.....		.75
63-234	Sensitivity Control.....		.75
63-236	500 Ohm..... (Power Bias) (Wide Metal).....		.25
63-237	1500 " " " " (Driver Bias) (Narrow Metal).....		.25
63-238	1000 " 1 " (1st Detector Cathode).....		.25
63-239	24M " 1 " (Oscillator Plate).....		.25
63-240	1900 " 1 " (R.F., 1st Detector & I.F. Grids).....		.25
63-242	2500 " 1 " (A. V. C. Cathode).....		.25
63-243	18M " 1 " (A. V. C. Cathode).....		.25
63-244	500 " 1 " (Acoustic Filter).....		.25
Coils			
20-33	Antenna Coil.....		.75
20-34	Oscillator Coil.....		.86
20-35	Detector Coil.....		1.00
S-2252	2nd Detector Plate Choke and Bracket.....		.50
95-135	1st I. F. Transformer (with Grid Lead).....		1.25
95-139	2nd I. F. Transformer (without Grid Lead).....		1.25

*22-115 R. F., 1st Detector, I. F. Grid Returns, I. F. Cathode, and Acoustic Filter.

VOLTAGE READINGS - MODELS 520 521
Meter 1000 Ohms Per Volt

Tube Type	Position	Fil. Volt.	Plate Volt.	Cath. Volt.	Screen Volt.	Plate Current
Z-58	R.F.	2.5	220	0	100	5.2
Z-58	1st Det.	2.5	220	42	100	3.
Z-56	Osc.	2.5	120	0	0	4.
Z-58	I.F.	2.5	220	0	100	6.
Z-56	2nd Det.	2.5	120	20	0	.75
Z-57	A.V.C.	2.5	40	-75	-2	0
Z-59	Driver	2.5	220	25	220	8.2
Z-59	Power	2.5	230	-65	230	25.
Z-59	Power	2.5	230	-65	230	25.
Z-80	Rect.	5.0	400*			62.5*

Line voltage 115 (Reading to Ground) Volume control maximum

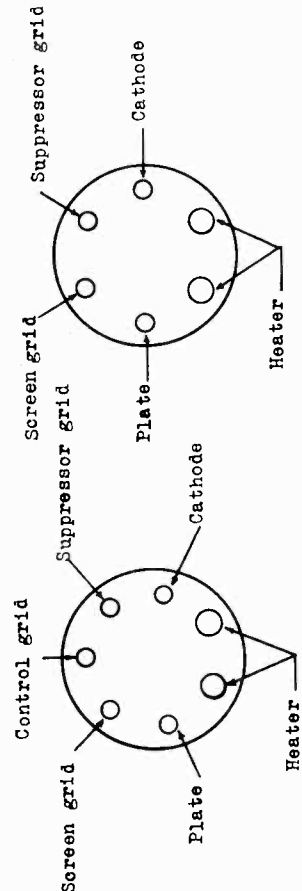

SIX and seven prong socket connections (Bottom of socket)

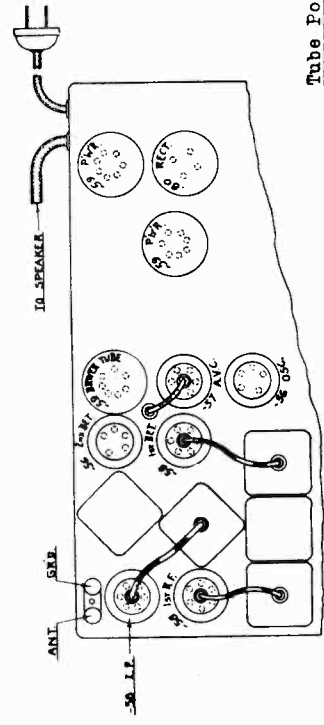

Tube Position

INTEROCEAN RADIO CORP.

MODEL 530, 531, 533

Chassis 2038

Schematic

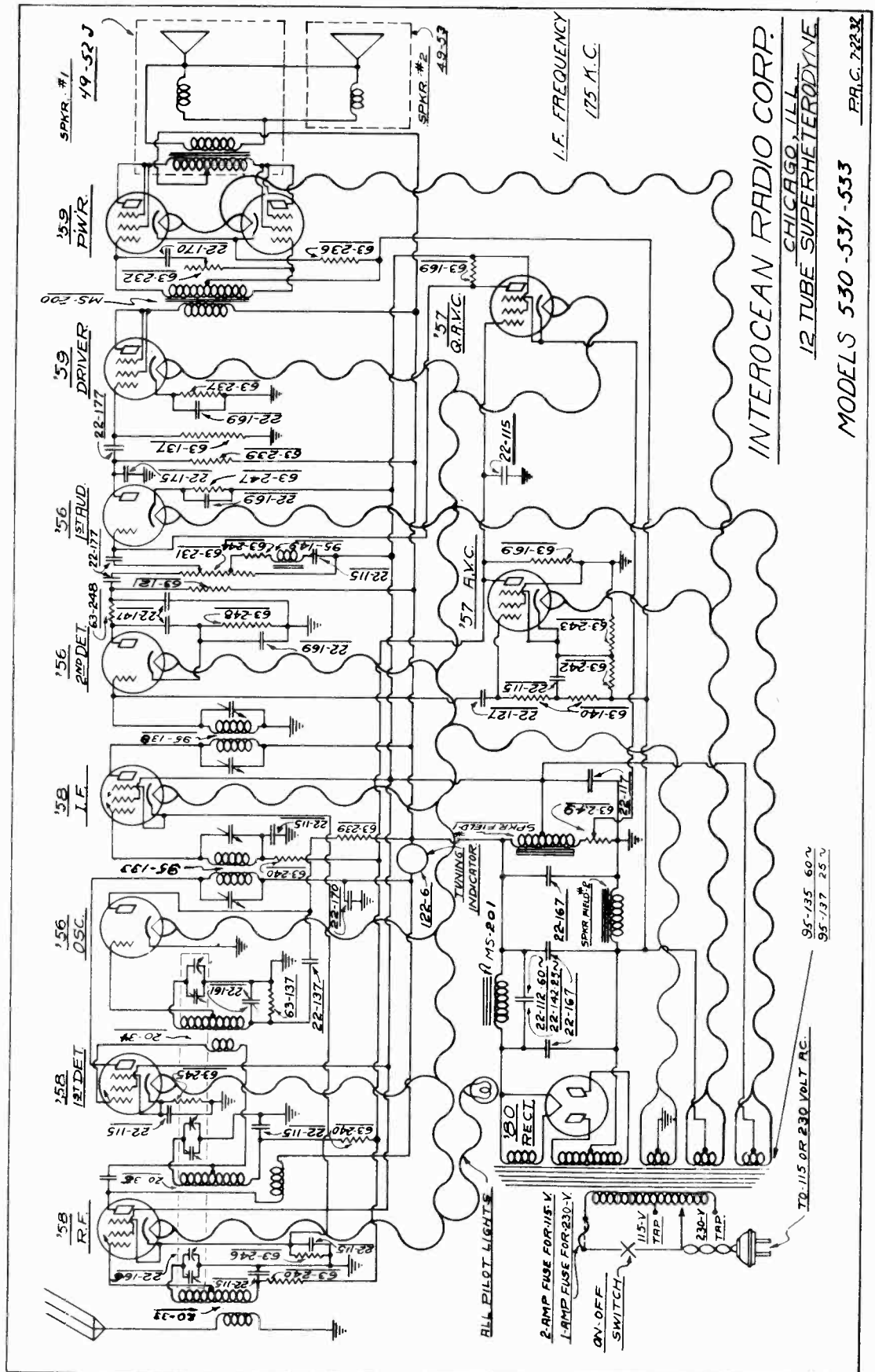

MODEL 530, 531, 533
Voltage, Socket
Alignment

INTEROCEAN RADIO CORP.

VOLTAGE READINGS - MODELS 530 531 533

Tube Type	Position	Fill. Volt.	Plate Volt.	Cath. Volt.	Screen Volt.	Supp. Volt.	Plate Current
2-56	1st R.F.	2.5	175	2.2	75	2.2	5.7
2-58	1st Det.	2.5	190	4.5	75	4.5	2.3
2-56	Osc.	2.5	100	0	-	-	3.5
2-58	1st I.F.	2.5	200	2.2	75	2.2	5.5
2-56	2nd Det.	2.5	110	10	-	-	3
2-56	1st Audio	2.5	170	80	-	-	8
2-57	A.V.C.	2.5	-	-45	-	-85	-
2-57	A.V.C.	2.5	30	13	75	13	-
2-59	Driver	2.5	190	20	190	190	13
2-59	Power	2.5	195	-70	195	195	22
2-59	Power	2.5	135	-70	195	195	22
2-80	Rect.	5.0	360	-	-	-	65

Antenna Disconnected
Meter 1000 Ohms Per Volt
Line Voltage 115 (Reading to Ground)
Volume control maximum
(All readings, with exception of heaters, taken from socket connections to ground. Use 1,000 ohm per volt D. C. meter.)

BALANCE I.F. frequency at 175 K.C. Condenser GARS at 1500 K.C. and oscillator padder at 600 K.C.

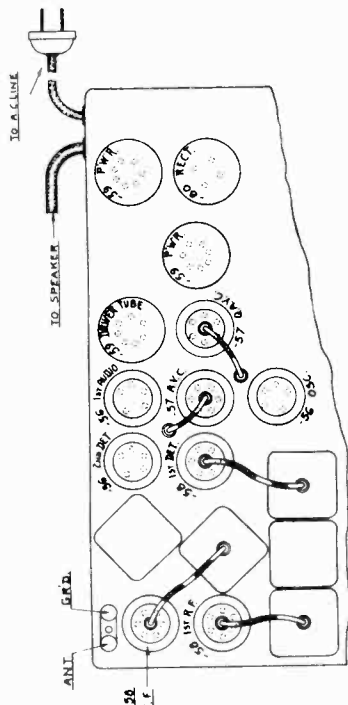

Tube Position

Part No.	Description	Quantity	Value	Notes	Price
11-5	Dial Pulley String	1		per ft.	.10
26-38	Calibrated Dial Strip	1			.15
60-69	Dial Cord Tension Spring	1			.01
80-85	Volume and Tone Control Dial Tension Spring	1			.01
83-274	Volume Control Dial Strip	1			.10
83-275	Tone Control Dial Strip	1			.10
100-18	2 1/2 Volt Pilot Lamp	1			.12
122-5	Shadowgraph Meter	1			2.00
Dial and Meter Assembly					
22-112	.1 mfd 300 volt...[Filter]	1			.25
22-115	.1 " 200 " ...[Sight Used, See Below]	1			.35
22-117	.5 " 300 " ...[Filter]	1			.50
22-127	.000025 600 " ...[A.V.C. Grid]	1			.35
22-137	.05 mfd 400 " ...[Oscillator Plate]	1			.25
22-142	.4 " 300 " ...[Filter 25 Cycle Only]	1			.40
22-147	.0005" 600 " ...[2nd Detector Plate]	1			.20
22-161	Padder	1			.45
22-165	Three Gang Variable	1			3.50
22-167	8. mfd 500 volt...[Filter]	1			1.50
22-169	8. " 50 " ...[2nd Det. Cathode, Driver Cathode & 1st Audio Cathode]	1			.55
22-170	.1 " 400 " ...[1st Det. Plate, Tone Control]	1			.25
22-175	.002 " 600 " ...[1st Audio Plate]	1			.25
22-177	.2 " 400 " ...[2nd Det. Plate, 1st Audio Grid, 1st Audio Plate]	1			.25
Resistors					
63-121	100M ohm 1 watt...[2nd Detector Plate]	1			.25
63-137	250M " 1/2 " ...[Driver Grid]	1			.25
63-140	1 meg " 1/2 " ...[A.V.C. Grid & Cathode]	1			.25
63-169	400 " 1/2 " ...[A.V.C. & A.V.C. Plate]	1			1.40
63-231	Volume Control & Switch Assembly	1			.75
63-232	Tone Control	1			.25
63-236	500 ohm ...[Wide Metal] [Power Tube Bias]	1			.25
63-237	1500 " ...[Narrow Metal] [Driver Tube Bias]	1			.25
63-239	24M " 1 watt... [Osc. & 1st Audio Plate]	1			.25
63-240	1900 " 1/2 " ...[R.F. 1st Det. & I.F. Grids]	1			.25
63-242	2500 " 1/2 " ...[A.V.C. Cathode]	1			.25
63-243	18M " 1 " ...[A.V.C. Cathode]	1			.25
63-244	500 " 1/2 " ...[Acoustic Filter]	1			.25
63-245	1500 " 1/2 " ...[1st Detector Cathode]	1			.25
63-246	150 " 1/2 " ...[R.F. Cathode]	1			.25
63-247	8M " 1/2 " ...[1st Audio Cathode]	1			.25
63-248	50M " 1 " ...[2nd Det. Plate & Cathode]	1			.25
63-249	Sensitivity & Quiet Control	1			.75
22-115	R.F. 1st Detector, I.F. Grid Returns, A.V.C. Plate, A.V.C. Cathode, 1st Detector Cathode, R.F. Cathode, and Acoustic Filter.	1			