



## **Certification Test Report**

**FCC ID: SK9OW1**

**FCC Rule Part: 15.247**

**Report Number: AT72135742-1P2**

Manufacturer: Itron, Inc.

Model: OW1

Test Begin Date: February 14, 2018

Test End Date: April 18, 2018

Report Issue Date: May 16, 2018



FOR THE SCOPE OF ACCREDITATION UNDER Certificate Number: AT-2021

This report must not be used by the client to claim product certification, approval, or endorsement by ANAB, NIST, or any agency of the Federal Government.

**Prepared by:**

A handwritten signature in blue ink, appearing to read 'R McGann'.

**Ryan McGann  
Senior Engineer  
TÜV SÜD America Inc.**

**Reviewed by:**

A handwritten signature in blue ink, appearing to read 'Jeremy Pickens'.

**Jeremy Pickens  
Senior Wireless Engineer  
TÜV SÜD America Inc.**

This test report shall not be reproduced except in full. This report may be reproduced in part with prior written consent of TÜV SÜD America Inc. The results contained in this report are representative of the sample(s) submitted for evaluation.

**This report contains 15 pages**

# TABLE OF CONTENTS

<b>1</b>	<b>GENERAL .....</b>	<b>3</b>
1.1	PURPOSE.....	3
1.2	PRODUCT DESCRIPTION .....	3
1.3	TEST METHODOLOGY AND CONSIDERATIONS .....	4
<b>2</b>	<b>TEST FACILITIES.....</b>	<b>5</b>
2.1	LOCATION .....	5
2.2	LABORATORY ACCREDITATIONS/RECOGNITIONS/CERTIFICATIONS .....	5
2.3	RADIATED EMISSIONS TEST SITE DESCRIPTION .....	6
2.3.1	<i>Semi-Anechoic Chamber Test Site</i> .....	6
2.3.2	<i>Open Area Tests Site (OATS)</i> .....	7
2.4	CONDUCTED EMISSIONS TEST SITE DESCRIPTION .....	8
<b>3</b>	<b>APPLICABLE STANDARD REFERENCES.....</b>	<b>8</b>
<b>4</b>	<b>LIST OF TEST EQUIPMENT.....</b>	<b>9</b>
<b>5</b>	<b>SUPPORT EQUIPMENT.....</b>	<b>10</b>
<b>6</b>	<b>EQUIPMENT UNDER TEST SETUP BLOCK DIAGRAM .....</b>	<b>10</b>
<b>7</b>	<b>SUMMARY OF TESTS.....</b>	<b>11</b>
7.1	ANTENNA REQUIREMENT – FCC: SECTION 15.203 .....	11
7.2	POWER LINE CONDUCTED EMISSIONS – FCC: SECTION 15.207; ISED CANADA: RSS-GEN 8.8.....	11
7.2.1	<i>Measurement Procedure</i> .....	11
7.2.2	<i>Measurement Results</i> .....	11
7.3	RADIATED SPURIOUS EMISSIONS – FCC: SECTIONS 15.205, 15.209; ISED CANADA: RSS-GEN	
8.9/8.10	.....	13
7.3.1	<i>Measurement Procedure</i> .....	13
7.3.2	<i>Measurement Results</i> .....	13
7.3.3	<i>Sample Calculation:</i> .....	14
<b>8</b>	<b>ESTIMATION OF MEASUREMENT UNCERTAINTY .....</b>	<b>15</b>
<b>9</b>	<b>CONCLUSION.....</b>	<b>15</b>

## 1 GENERAL

### 1.1 Purpose

The purpose of this report is to demonstrate compliance with Part 15 Subpart C of the FCC's Code of Federal Regulations for a Class II Permissive Change.

The purpose of this Class II Permissive Change is to add a new antenna and host combination.

### 1.2 Product description

The Itron OW1 is a communications module which includes a 902.2 MHz to 927.8 MHz transmitter. The module operates on DC voltage which is supplied by a host device.

This Class II Permissive Change addresses the OW1 (FCC ID: SK9OW1) integrated into the Itron, Inc. Socket Based Cellular Router (SBCR) with new PCB antenna configuration.

This test report documents the compliance of the 900 MHz transceiver DSS hopping mode of operation.

#### Technical Details:

Detail	Description
Frequency Range	902.2 – 927.8 MHz
Number of Channels	FSK 150kbps: 64 OFDM: 64 DSSS: 64
Modulation Format	FSK, OFDM, DSSS
Data Rates (kbps)	FSK: 150 OFDM: 200, 600 DSSS: 12.5
Operating Voltage	24Vdc (Supplied by host)
Antenna Type(s) / Gain(s)	Monopole Antenna: 2.8 dBi PCTel BOA9028 Omni Antenna: 8.15dBi* Antenna Products AMR 360-902-5-T0-N Omni Antenna: 5.1 dBi PCB Trace Antenna (new): 2.04 dBi

#### Manufacturer Information:

Itron, Inc.  
313 N Hwy 11  
West Union, SC 29696

EUT Serial Numbers: FCC2 (Host S/N)

Test Sample Condition: The test samples were provided in good working order with no visible defects.

### 1.3 Test Methodology and Considerations

All modes of operation, including all available data rates, were evaluated for each mode. The data presented in this report represents the worst case where applicable.

The purpose of this Class II Permissive Change is to add a new antenna and host to the originally certified module, therefore this evaluation is limited to Radiated Emissions testing and AC Power Line Conducted Emissions testing only

For radiated emissions, the EUT was evaluated in the Socket Based Cellular Router (SBCR). The data rates evaluated were FSK 150kbps, OFDM 200 and 600kbps, and DSSS 12.5kbps.

For AC power line conducted emissions the EUT was evaluated installed in the Socket Based Cellular Router (SBCR) powered from 240Vac, 60Hz.

Radiated inter-modulation testing was performed for all combinations of simultaneous transmission and found to comply.

Power setting during test – FSK 150kbps:	-2
Power setting during test – OFDM 200/600:	+4
Power setting during test – DSSS 12.5k:	+2

## 2 TEST FACILITIES

### 2.1 Location

The radiated and conducted emissions test sites are located at the following address:

TÜV SÜD America, Inc.  
5015 B.U. Bowman Drive  
Buford, GA 30518  
Phone: (770) 831-8048  
Fax: (770) 831-8598

### 2.2 Laboratory Accreditations/Recognitions/Certifications

TÜV SÜD America, Inc. is accredited to ISO/IEC 17025 by the ANSI-ASQ National Accreditation Board/ANAB accreditation program, and has been issued certificate number AT-2021 in recognition of this accreditation. Unless otherwise specified, all tests methods described within this report are covered under the ISO/IEC 17025 scope of accreditation.

The Semi-Anechoic Chamber Test Site, Open Area Test Site (OATS) and Conducted Emissions Site have been fully described, submitted to, and accepted by the FCC, Innovation, Science, and Economic Development Canada and the Japanese Voluntary Control Council for Interference by information technology equipment.

FCC Registration Number: 391271

Innovation, Science, and Economic Development Canada Lab Code: 23597

VCCI Member Number: 1831

- VCCI OATS Registration Number R-1526
- VCCI Conducted Emissions Site Registration Number: C-1608

## 2.3 Radiated Emissions Test Site Description

### 2.3.1 Semi-Anechoic Chamber Test Site

The Semi-Anechoic Chamber Test Site consists of a 20' x 30' x 18' shielded enclosure. The chamber is lined with Toyo Ferrite Grid Absorber, model number FFG-1000. The ferrite tile grid is 101 x 101 x 19mm thick and weighs approximately 550 grams. These tiles are mounted on steel panels and installed directly on the inner walls of the chamber.

The turntable is 150cm in diameter and is located 160cm from the back wall of the chamber. The chamber is grounded via 1 – 8' copper ground rod, installed at the center of the back wall, it is bound to the ground plane using 3/4" stainless steel braided cable.

The turntable is all steel, flush mounted table installed in an all steel frame. The table is remotely operated from inside the control room located 25' from the range. The turntable is electrically bonded to the surrounding ground plane via steel fingers installed on the edge of the turn table. The steel fingers make constant contact with the ground plane during operation.

Behind the turntable is a 3' x 6' x 4' deep shielded pit used for support equipment if necessary. The pit is equipped with 1 – 4" PVC chases from the turntable to the pit that allow for cabling to the EUT if necessary. The underside of the turntable can be accessed from the pit so cables can be supplied to the EUT from the pit.

A diagram of the Semi-Anechoic Chamber Test Site is shown in Figure 2.3-1 below:

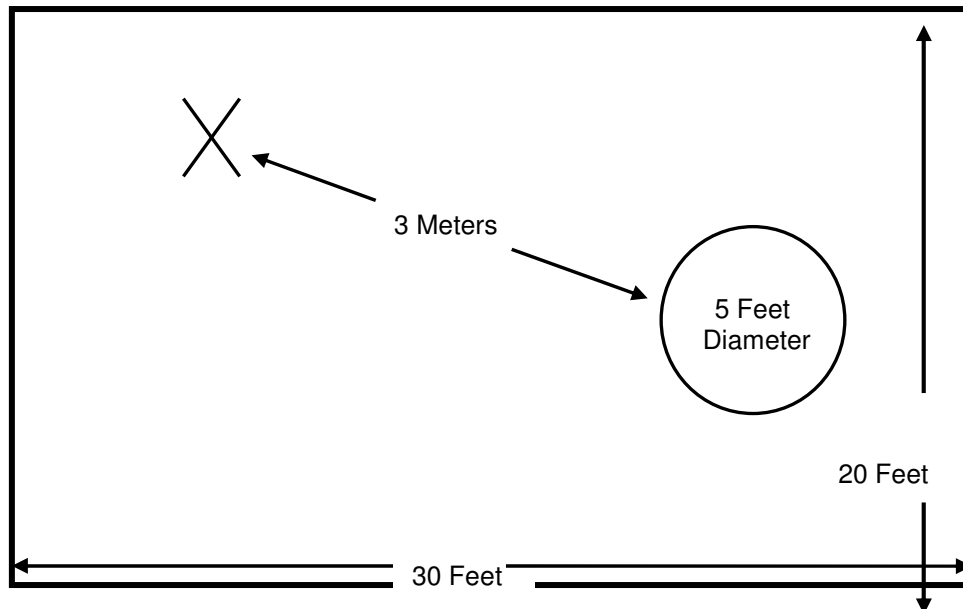

Figure 2.3-1: Semi-Anechoic Chamber Test Site

### 2.3.2 Open Area Tests Site (OATS)

The open area test site consists of a 40' x 66' concrete pad covered with a perforated electro-plated galvanized sheet metal. The perforations in the sheet metal are 1/8" holes that are staggered every 3/16". The individual sheets are placed to overlap each other by 1/4" and are riveted together to provide a continuous seam. Rivets are spaced every 3" in a 3 x 20 meter perimeter around the antenna mast and EUT area. Rivets in the remaining area are spaced as necessary to properly secure the ground plane and maintain the electrical continuity.

The entire ground plane extends 12' beyond the turntable edge and 16' beyond the antenna mast when set to a 10 meter measurement distance. The ground plane is grounded via 4 – 8' copper ground rods, each installed at a corner of the ground plane and bound to the ground plane using 3/4" stainless steel braided cable.

The turntable is an all aluminum 10' flush mounted table installed in an all aluminum frame. The table is remotely operated from inside the control room located 40' from the range. The turntable is electrically bonded to the surrounding ground plane via steel fingers installed on the edge of the turn table. The steel fingers make constant contact with the ground plane during operation.

Adjacent to the turntable is a 7' x 7' square and 4' deep concrete pit used for support equipment if necessary. The pit is equipped with 5 – 4" PVC chases from the pit to the control room that allow for cabling to the EUT if necessary. The underside of the turntable can be accessed from the pit so cables can be supplied to the EUT from the pit. The pit is covered with 2 sheets of 1/4" diamond style re-enforced steel sheets. The sheets are painted to match the perforated steel ground plane; however, the underside edges have been masked off to maintain the electrical continuity of the ground plane. All reflecting objects are located outside of the ellipse referenced in ANSI C63.10.

A diagram of the Open Area Test Site is shown in Figure 2.3-2 below:

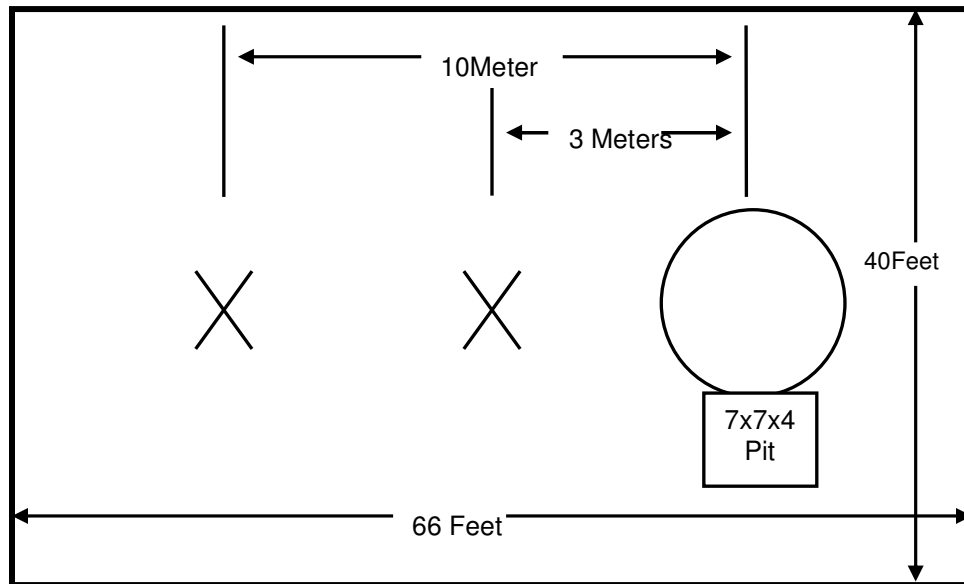

Figure 2.3-2: Open Area Test Site

## 2.4 Conducted Emissions Test Site Description

The AC mains conducted EMI site is located in the main EMC lab. It consists of an 8' x 8' solid aluminum horizontal ground reference plane (GRP) bonded every 3" to an 8' X 8' vertical ground plane.

The site is of sufficient size to test table top and floor standing equipment in accordance with ANSI C63.10.

A diagram of the room is shown below in figure 2.4-1:

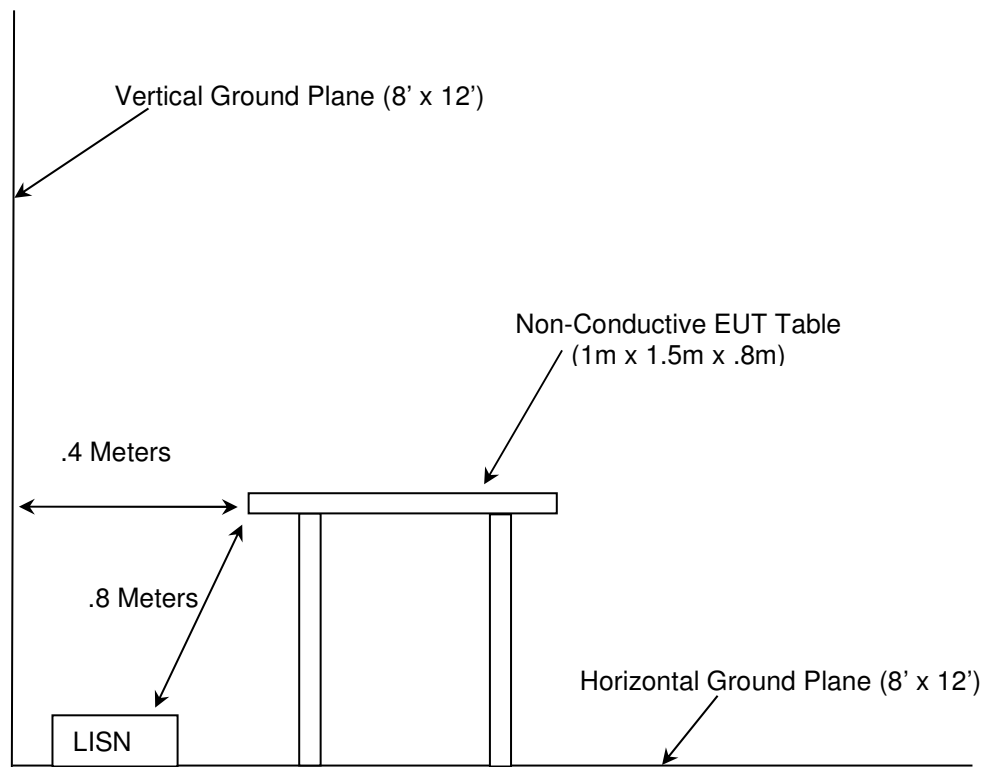

Figure 2.4-1: AC Mains Conducted EMI Site

## 3 APPLICABLE STANDARD REFERENCES

The following standards were used:

- ❖ ANSI C63.10-2013: American National Standard of Procedures for Compliance Testing of Unlicensed Wireless Devices
- ❖ US Code of Federal Regulations (CFR): Title 47, Part 2, Subpart J: Equipment Authorization Procedures, 2018
- ❖ US Code of Federal Regulations (CFR): Title 47, Part 15, Subpart C: Radio Frequency Devices, Intentional Radiators, 2018
- ❖ ISED Canada Radio Standards Specification: RSS-247 – Digital Transmission Systems (DTSS), Frequency Hopping Systems (FHSs) and License-Exempt Local Area Network (LE-LAN) Devices, Issue 2, Feb 2017
- ❖ ISED Canada Radio Standards Specification: RSS-GEN – General Requirements and Information for the Certification of Radiocommunication Equipment, Issue 4, Nov 2014.



#### 4 LIST OF TEST EQUIPMENT

The calibration interval of test equipment is annually or the manufacturer's recommendations. Where the calibration interval deviates from the annual cycle based on the instrument manufacturer's recommendations, it shall be stated below.

**Table 4-1: Test Equipment**

AssetID	Manufacturer	Model #	Equipment Type	Serial #	Last Calibration Date	Calibration Due Date
30	Spectrum Technologies	DRH-0118	1-18GHz Horn Antenna	970102	05/09/2017	05/09/2019
40	EMCO	3104	Bicon Antenna	3211	06/08/2016	06/08/2018
167	ACS	Chamber EMI Cable Set	Consists of cables 485, 242, 204 and 10	167	09/29/2017	09/29/2018
168	Hewlett Packard	11947A	Transient Pulse Limiter	44829	01/22/2018	01/22/2019
213	TEC	PA 102	Amplifier	44927	07/24/2017	07/24/2018
324	ACS	Belden	Conducted EMI Cable	8214	03/21/2017	03/21/2018
324	ACS	Belden	Conducted EMI Cable	8214	04/05/2018	04/05/2019
331	Microwave Circuits	H1G513G1	Microwave Bandpass Filter	31417	05/13/2017	05/13/2018
338	Hewlett Packard	8449B	High Frequency Pre-Amp	3008A01111	07/11/2017	07/11/2019
412	Electro Metrics	LPA-25	Log Periodic Antenna	1241	08/08/2016	08/08/2018
422	Florida RF	SMS-200AW-72.0-SMR	Cable	805	11/27/2017	11/27/2018
616	Florida RF Cables	SMRE-200W-12.0-SMRE	High Frequency Cable	N/A	10/07/2017	10/07/2018
676	Florida RF Labs	SMS-290AW-480.0-SMS	Cable	MFR2Y194	01/08/2018	01/08/2019
813	PMM	9010	EMI Receiver; RF Input 50ohm; 10Hz-50MHz; 10Hz-30MHz	697WW30606	02/12/2018	02/12/2019
819	Rohde & Schwarz USA, Inc.	ESR26	EMI Test Receiver	101345	10/31/2017	10/31/2018
3010	Rohde & Schwarz	ENV216	Two-Line V-Network	3010	07/11/2017	07/11/2018

**NCR = No Calibration Required**

**NOTE: All test equipment was used only during active calibration cycles.**

## 5 SUPPORT EQUIPMENT

**Table 5-1: Support Equipment – Radiated Emissions**

Item	Equipment Type	Manufacturer	Model/Part Number	Serial Number
1	Host Device	Itron, Inc.	SBCR	FCC2

**Table 5-2: Cable Description – Radiated Emissions**

Cable	Cable Type	Length	Shield	Termination
A	AC Power Cable	1.75 m	No	Host Device to AC Mains

## 6 EQUIPMENT UNDER TEST SETUP BLOCK DIAGRAM

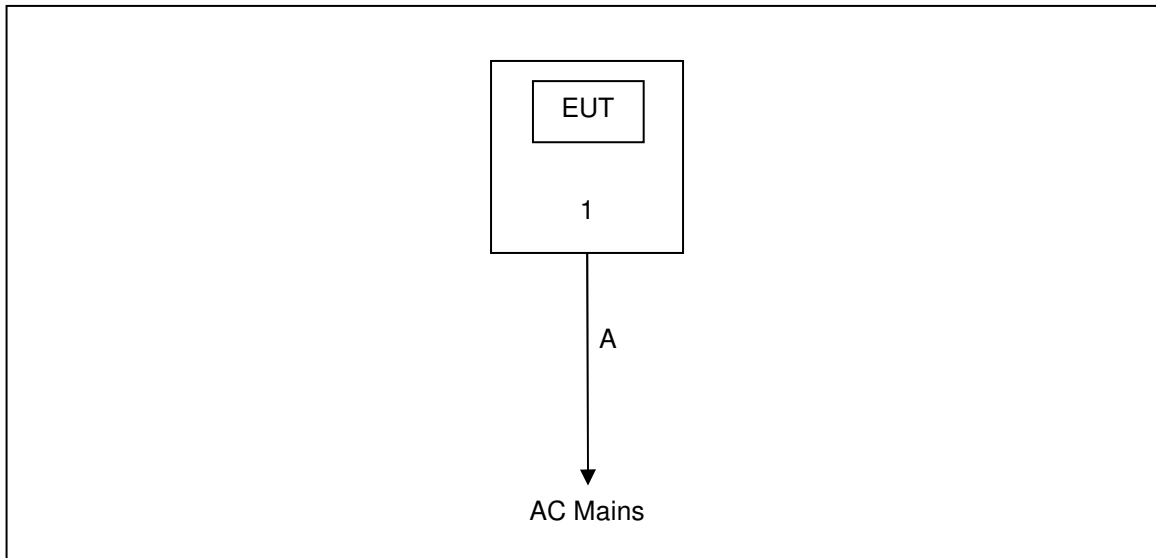

**Figure 6-1: Test Setup Block Diagram**

## 7 SUMMARY OF TESTS

Along with the tabular data shown below, plots were taken of all signals deemed important enough to document.

### 7.1 Antenna Requirement – FCC: Section 15.203

When installed in the Itron, Inc. Socket Based Cellular Router (SBCR) the EUT utilizes an internal PCB trace antenna with a peak gain of 2.04dBi in the 900-928MHz ISM band. The EUT and host device require professional installation, therefore meeting the requirements of Section 15.203.

### 7.2 Power Line Conducted Emissions – FCC: Section 15.207; ISED Canada: RSS-Gen 8.8

#### 7.2.1 Measurement Procedure

Conducted emissions were performed from 150 kHz to 30 MHz with the spectrum analyzer's resolution bandwidth set to 9 kHz and the video bandwidth set to 30 kHz. The calculation for the conducted emissions is as follows:

**Corrected Reading = Analyzer Reading + LISN Loss + Cable Loss**

**Margin = Corrected Reading - Applicable Limit**

#### 7.2.2 Measurement Results

Performed by: Arthur Sumner

**Table 7.2.2-1: Conducted EMI Results – Line 1**

Frequency (MHz)	Corrected Reading		Limit		Margin		
	Quasi-Peak (dBuV)	Average (dBuV)	Quasi-Peak (dBuV)	Average (dBuV)	Quasi-Peak (dB)	Average (dB)	Correction (dB)
0.162	45.04	34.56	65.36	55.36	-20.32	-20.8	9.58
0.226	43.39	33.84	62.6	52.6	-19.21	-18.76	9.58
0.394	41.49	25.76	57.98	47.98	-16.49	-22.22	9.59
0.41	51.01	46.83	57.65	47.65	-6.64	-0.82	9.59
0.418	50.56	40.2	57.49	47.49	-6.93	-7.29	9.59
0.43	47.49	31.53	57.25	47.25	-9.76	-15.72	9.59
0.694	48.13	40.5	56	46	-7.87	-5.5	9.59
1.286	47.74	38.06	56	46	-8.26	-7.94	9.6
1.678	45.97	38.12	56	46	-10.03	-7.88	9.61
18.358	45.89	42.93	60	50	-14.11	-7.07	9.83

Table 7.2.2-2: Conducted EMI Results – Line 2

Frequency (MHz)	Corrected Reading		Limit		Margin		
	Quasi-Peak (dBuV)	Average (dBuV)	Quasi-Peak (dBuV)	Average (dBuV)	Quasi-Peak (dB)	Average (dB)	Correction (dB)
0.158	47.55	25.89	65.57	55.57	-18.02	-29.68	9.58
0.17	46.78	22.78	64.96	54.96	-18.18	-32.18	9.58
0.182	45.09	31.8	64.39	54.39	-19.3	-22.59	9.58
0.198	43.76	27.43	63.69	53.69	-19.93	-26.26	9.58
0.23	43.57	36.2	62.45	52.45	-18.88	-16.25	9.58
0.282	41.1	35.86	60.76	50.76	-19.66	-14.9	9.59
0.402	46.91	35.46	57.81	47.81	-10.9	-12.35	9.59
0.434	45.47	30.58	57.18	47.18	-11.71	-16.6	9.59
0.454	49.12	42.73	56.8	46.8	-7.68	-4.07	9.59
18.51	44.58	41.59	60	50	-15.42	-8.41	9.86

### 7.3 Radiated Spurious Emissions – FCC: Sections 15.205, 15.209; ISED Canada: RSS-Gen 8.9/8.10

#### 7.3.1 Measurement Procedure

Radiated emissions tests were made over the frequency range of 30 MHz to 10 GHz, 10 times the highest fundamental frequency.

The EUT was rotated through 360° and the receive antenna height was varied from 1 meter to 4 meters so that the maximum radiated emissions level would be detected. For frequencies below 1000 MHz, quasi-peak measurements were made using a resolution bandwidth RBW of 120 kHz and a video bandwidth VBW of 300 kHz. For frequencies above 1000 MHz, peak and average measurements were made with RBW and VBW of 1 MHz and 3 MHz respectively.

The EUT was caused to generate a continuous modulated carrier at each of the low, middle, and high channels.

Each emission found to be in a restricted band was compared to the applicable radiated emission limits.

#### 7.3.2 Measurement Results

Performed by: Tyler Leeson, Mark Afrozi, Arthur Sumner

**Table 7.3.2-1: Radiated Spurious Emissions Tabulated Data – FSK Modulation 150kbps**

Frequency (MHz)	Level (dBuV)		Antenna Polarity (H/V)	Correction Factors (dB)	Corrected Level (dBuV/m)		Limit (dBuV/m)		Margin (dB)	
	pk	Qpk/Avg			pk	Qpk/Avg	pk	Qpk/Avg	pk	Qpk/Avg
<b>Low Channel</b>										
2707.2	50.10	42.50	H	-2.95	47.15	39.55	74.0	54.0	26.8	14.4
2707.2	48.60	38.10	V	-2.95	45.65	35.15	74.0	54.0	28.3	18.8
3609.6	47.10	33.80	V	0.41	47.51	34.21	74.0	54.0	26.5	19.8
<b>Middle Channel</b>										
2745.6	52.40	46.70	H	-2.81	49.59	43.89	74.0	54.0	24.4	10.1
2745.6	50.60	42.90	V	-2.81	47.79	40.09	74.0	54.0	26.2	13.9
4576	48.60	37.20	V	2.47	51.07	39.67	74.0	54.0	22.9	14.3
<b>High Channel</b>										
2782.8	52.20	46.10	H	-2.68	49.52	43.42	74.0	54.0	24.5	10.6
2782.8	50.80	42.70	V	-2.68	48.12	40.02	74.0	54.0	25.9	14.0
4638	48.50	37.80	V	2.70	51.20	40.50	74.0	54.0	22.8	13.5

**Table 7.3.2-2: Radiated Spurious Emissions Tabulated Data – OFDM 200kbps**

Frequency (MHz)	Level (dBuV)		Antenna Polarity (H/V)	Correction Factors (dB)	Corrected Level (dBuV/m)		Limit (dBuV/m)		Margin (dB)	
	pk	Qpk/Avg			pk	Qpk/Avg	pk	Qpk/Avg	pk	Qpk/Avg
<b>Low Channel</b>										
2707.2	57.70	43.80	H	-3.82	53.88	39.98	74.0	54.0	20.1	14.0
2707.2	52.10	37.00	V	-3.82	48.28	33.18	74.0	54.0	25.7	20.8
<b>Middle Channel</b>										
Radiated spurious emissions were attenuated below the noise floor of the measurement instrumentation										
<b>High Channel</b>										
2782.8	54.10	37.50	H	-3.58	50.52	33.92	74.0	54.0	23.5	20.1
2782.8	51.50	37.60	V	-3.58	47.92	34.02	74.0	54.0	26.1	20.0

Table 7.3.2-3: Radiated Spurious Emissions Tabulated Data – OFDM 600kbps

Frequency (MHz)	Level (dBuV)		Antenna Polarity (H/V)	Correction Factors (dB)	Corrected Level (dBuV/m)		Limit (dBuV/m)		Margin (dB)	
	pk	Qpk/Avg			pk	Qpk/Avg	pk	Qpk/Avg	pk	Qpk/Avg
<b>Low Channel</b>										
2707.2	54.50	40.10	H	-3.82	50.68	36.28	74.0	54.0	23.3	17.7
<b>Middle Channel</b>										
2745.6	53.90	39.10	H	-3.70	50.20	35.40	74.0	54.0	23.8	18.6
2745.6	53.20	37.10	V	-3.70	49.50	33.40	74.0	54.0	24.5	20.6
<b>High Channel</b>										
Radiated spurious emissions were attenuated below the noise floor of the measurement instrumentation										

Table 7.3.2-4: Radiated Spurious Emissions Tabulated Data – DSSS 12.5kbps

Frequency (MHz)	Level (dBuV)		Antenna Polarity (H/V)	Correction Factors (dB)	Corrected Level (dBuV/m)		Limit (dBuV/m)		Margin (dB)	
	pk	Qpk/Avg			pk	Qpk/Avg	pk	Qpk/Avg	pk	Qpk/Avg
<b>Low Channel</b>										
2707.2	54.18	48.11	H	-2.95	51.23	45.16	74.0	54.0	22.8	8.8
2707.2	51.31	41.27	V	-2.95	48.36	38.32	74.0	54.0	25.6	15.7
<b>Middle Channel</b>										
2745.6	52.77	45.84	H	-2.81	49.96	43.03	74.0	54.0	24.0	11.0
2745.6	52.67	44.81	V	-2.81	49.86	42.00	74.0	54.0	24.1	12.0
<b>High Channel</b>										
2782.8	53.39	46.22	H	-2.68	50.71	43.54	74.0	54.0	23.3	10.5
2782.8	52.67	44.47	V	-2.68	49.99	41.79	74.0	54.0	24.0	12.2

### 7.3.3 Sample Calculation:

$$R_c = R_u + CF_T$$

Where:

- $CF_T$  = Total Correction Factor (AF+CA+AG)-DC (Average Measurements Only)  
 $R_u$  = Uncorrected Reading  
 $R_c$  = Corrected Level  
 AF = Antenna Factor  
 CA = Cable Attenuation  
 AG = Amplifier Gain  
 DC = Duty Cycle Correction Factor

#### Example Calculation: Peak – FSK Modulation 150kbps

Corrected Level:  $50.10 - 2.95 = 47.15 \text{ dBuV/m}$

Margin:  $74 \text{ dBuV/m} - 47.15 \text{ dBuV/m} = 26.8 \text{ dB}$

#### Example Calculation: Average – FSK Modulation 150kbps

Corrected Level:  $42.50 - 2.95 - 0 = 39.55 \text{ dBuV}$

Margin:  $54 \text{ dBuV} - 39.55 \text{ dBuV} = 14.4 \text{ dB}$

## 8 ESTIMATION OF MEASUREMENT UNCERTAINTY

The expanded laboratory measurement uncertainty figures ( $U_{\text{Lab}}$ ) provided below correspond to an expansion factor (coverage factor)  $k = 1.96$  which provide confidence levels of 95%.

Parameter	$U_{\text{lab}}$
Occupied Channel Bandwidth	$\pm 0.009 \%$
RF Conducted Output Power	$\pm 0.349 \text{ dB}$
Power Spectral Density	$\pm 0.372 \text{ dB}$
Antenna Port Conducted Emissions	$\pm 1.264 \text{ dB}$
Radiated Emissions $\leq 1 \text{ GHz}$	$\pm 5.814 \text{ dB}$
Radiated Emissions $> 1 \text{ GHz}$	$\pm 4.318 \text{ dB}$
Temperature	$\pm 0.860 \text{ }^\circ\text{C}$
Radio Frequency	$\pm 2.832 \times 10^{-8}$
AC Power Line Conducted Emissions	$\pm 3.360 \text{ dB}$

## 9 CONCLUSION

In the opinion of TÜV SÜD America, Inc. the OW1, manufactured by Itron, Inc. meets the requirements of FCC Part 15 subpart C for the tests documented in this test report.

# END REPORT