

Werkzeughalter-Programm

AS-200 (12 ST)
AS-200 (15 ST)
JX-250
MX-100
NTJ-100
NTY³-100, WY-100 II (12 ST)
NTY³-150, 250, WY-150, 250
SC-100
SC-200
SC-250
SC-300 II
SC-450
Super NTJ
Super NTX
TW-30
WT-100
WT-150, WT-150 II, WT-250 II
WT-300

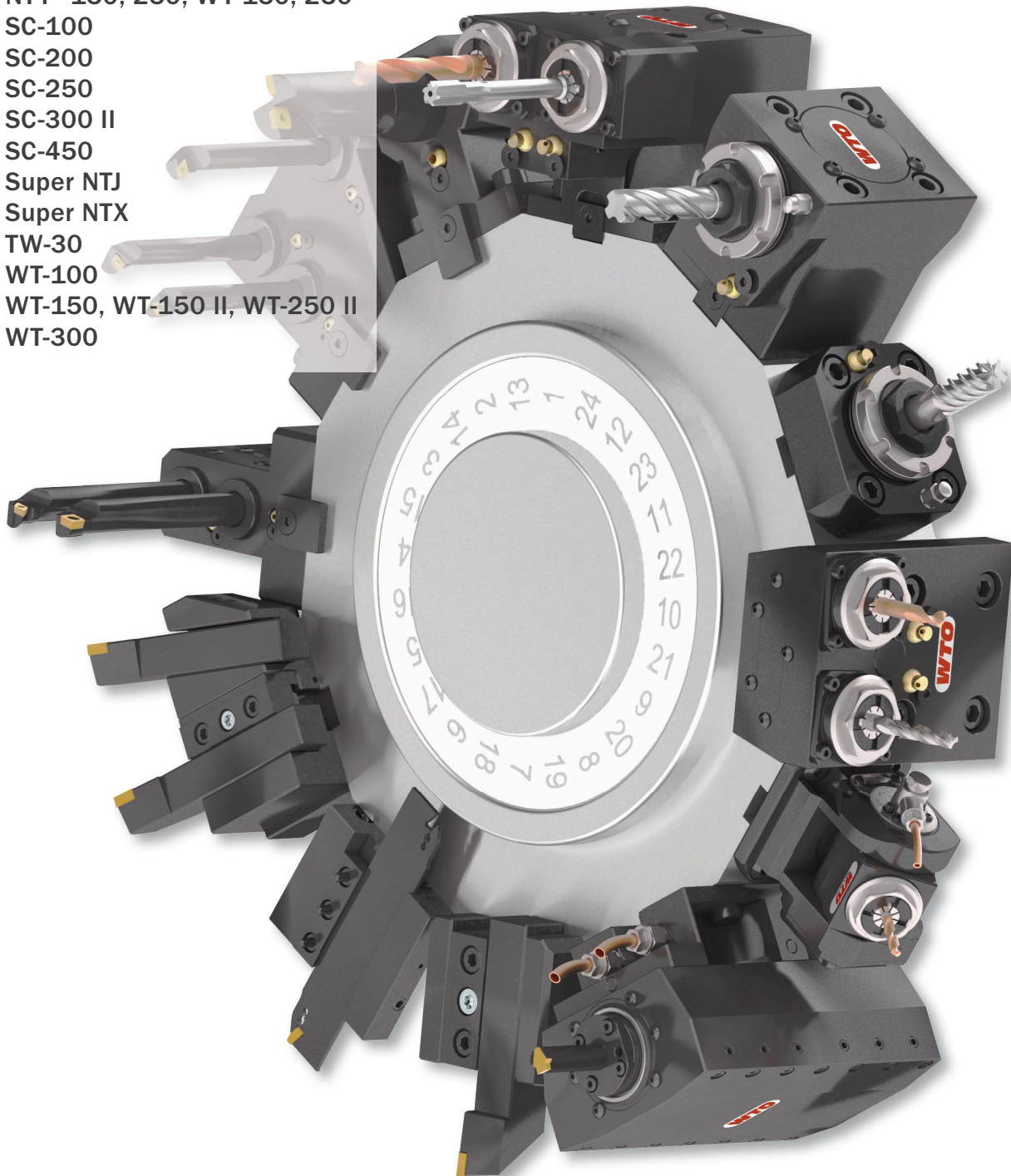

QuickFlex®

Das neue Schnellwechsel-Werkzeugsystem
für hohe Performance und Präzision.

Minimale Investition, maximale Erweiterungsmöglichkeit.



AS-200 (12 ST)	Seite	4 - 6
AS-200 (15 ST)	Seite	7 - 9
JX-250	Seite	10 - 12
MX-100	Seite	13 - 15
NTJ-100	Seite	16 - 18
NTY ³ -100, WY-100 II (12 ST)	Seite	19 - 22
NTY ³ -150, 250, WY-150, 250	Seite	23 - 26
SC-100	Seite	27 - 29
SC-200	Seite	30 - 32
SC-250	Seite	33 - 36
SC-300 II	Seite	37 - 39
SC-450	Seite	40 - 40
Super NTJ	Seite	41 - 43
Super NTX	Seite	44 - 46
TW-30	Seite	47 - 47
WT-100	Seite	48 - 50
WT-150, WT-150 II, WT-250 II	Seite	51 - 54
WT-300	Seite	55 - 57
Reduzierhülsen	Seite	58 - 58
Spannzangen	Seite	59 - 61

EK = Externe Kühlmittelzufuhr
HDIK=Hochdruck interne Kühlmittelzufuhr durch das Schneidwerkzeug
IK 80 bar = Interne und externe Kühlmittelzufuhr
 Max. Kühlmitteldruck = 80 bar
IK 30 bar = Interne und externe Kühlmittelzufuhr
 Max. Kühlmitteldruck = 30 bar
 Nur gefiltertes Kühlmittel verwenden (max. 50 µm Partikelgröße)
 Kein Trockenlauf!
 Nicht für die Bearbeitung von Gussmaterialien,
 wie z. B. Grauguss, verwenden.

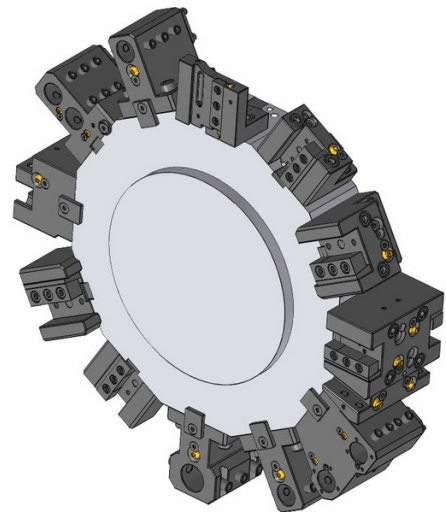
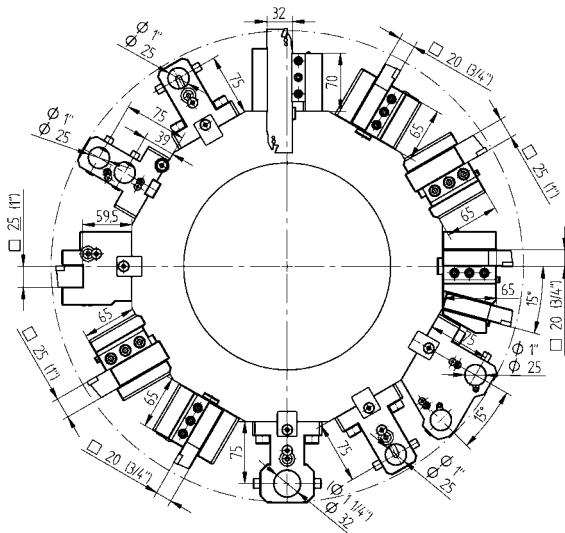

Stehende Werkzeughalter - Standard Programm



20
25

Plan- und Längsdrehhalter

48-108585
48-106720



25

Plan- und Längsdrehhalter, HD-IK

48-106720-HP IK 80 bar



20

Plan- und Längsdrehhalter, beidseitig

48-108460



20

Plandrehhalter

48-108590



25

Plandrehhalter

48-107758

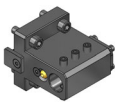

Ø 25
Ø 32

Kombihalter

48-107842 IK 80 bar
48-106727 IK 80 bar

Stehende Werkzeughalter - Erweitertes Programm



20

Plan- und Längsdrehhalter, 2-fach, 24 Stationen (nur für Revolver-SW375)

48-108784 EK



20

Plan- und Längsdrehhalter, beidseitig, 2-fach, 24 Stationen (nur für Revolver-SW375)

48-108786 EK

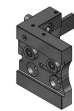

SH 32

Abstechhalter

48-99637



SH 32
SH 32

Abstechhalter, HD-IK

48-102276R IK 80 bar
48-102276L IK 80 bar

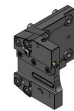

SH 32
SH 32

Abstechhalter, einstellbar, HD-IK

48-109656R IK 80 bar
343-810100R87
48-109656L IK 80 bar
343-810100L87

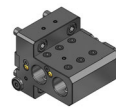

Ø 25

Kombihalter, 2-fach

48-108792 IK 80 bar

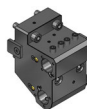

Ø 25

Kombihalter, beidseitig, 2-fach, 24 Stationen (nur für Revolver-SW375)

48-108794 IK 80 bar

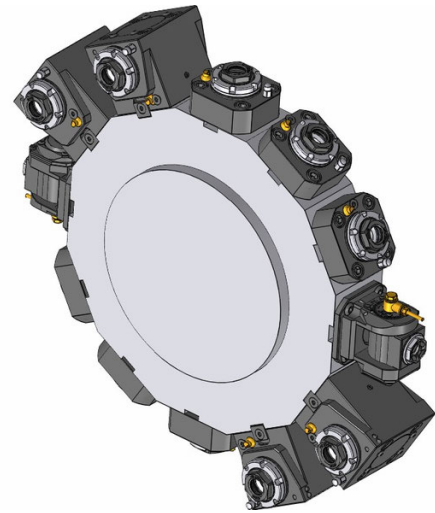
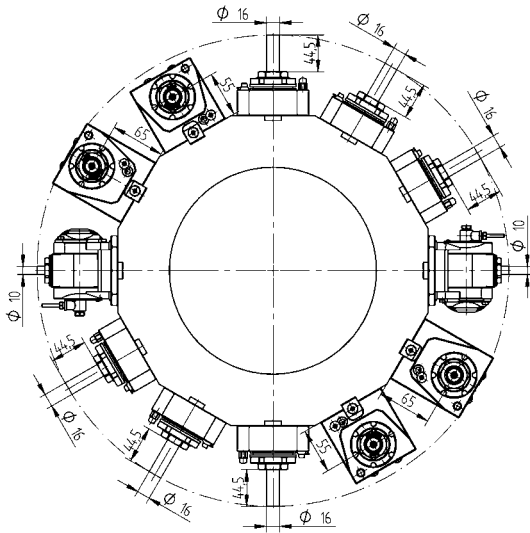

Angetriebene Werkzeughalter - QuickFlex®

Angetriebene Werkzeughalter - Erweitertes Programm



Bohr-Fräseinrichtung - gerade

- ER-25 QF 420125022-55 1:1 EK
0067725000
- ER-25 QF 420125023-55 1:1 IK 80 bar
0067725000

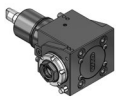

Winkel-Bohr-Fräseinrichtung, LF=55

- ER-25 QF 420525087-55 1:1 EK
0067725000
- ER-25 QF 420525088-55 1:1 IK 80 bar
0067725000

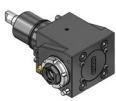

Winkel-Bohr-Fräseinrichtung, LF=65

- ER-25 QF 420525085-55 1:1 EK
0067725000
- ER-25 QF 420525086-55 1:1 IK 80 bar
0067725000



Winkel-Bohr-Fräseinrichtung, beidseitig, LF=55

- ER-25 QF 420525069-55 1:1 EK
0067725000



Winkel-Bohr-Fräseinrichtung, beidseitig, LF=65

- ER-25 QF 420525077-55 1:1 EK
0067725000



Bohr-Fräseinrichtung - gerade

- ER 32 410120002-55 1:1 EK
0067825000
- ER 32 410120003-55 1:1 IK 80 bar
0067825000

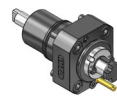

Fräseinrichtung - gerade

- Ø 22 410222002-55 1:1 EK
00675000483



Bohr-Fräseinrichtung - gerade mit Versatz

- ER 25 410116027-55 1:1 EK
00675000932
- ER 25 410116028-55 1:1 IK 80 bar
00675000932
- ER 20 410113006-55 1:2 EK
00675000939
- ER 20 410113004-55 1:2 IK 80 bar
00675000939
- ER 16 410410000-55 1:3 EK
00675000937
- ER 16 410410001-55 1:3 IK 80 bar
00675000937
- ER 25 410116021-55 2:1 EK
00675000932
- ER 25 410116022-55 2:1 IK 80 bar
00675000932

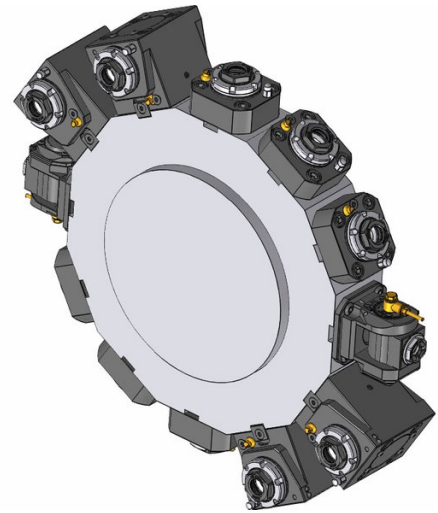
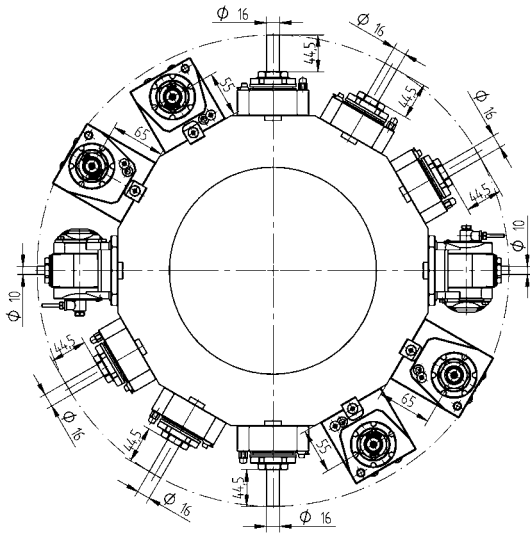

Angetriebene Werkzeughalter - Erweitertes Programm

Angetriebene Werkzeughalter - Erweitertes Programm



Winkel-Bohr-Fräseinrichtung, LF=65

ER 32	410520045-55 0067825000	1:1	EK
ER 32	410520046-55 0067825000	1:1	IK 80 bar
ER-20 QF	420520029-55 0067720001	1:2	EK
ER-20 QF	420520030-55 0067720001	1:2	IK 80 bar
ER 16	410810022-55 00675000841	1:3	EK
ER 16	410810023-55 00675000841	1:3	IK 80 bar
ER-25 QF	420525055-55 0067725000	2:1	EK
ER-25 QF	420525056-55 0067725000	2:1	IK 80 bar



Bohr-Fräseinrichtung - winkelverstellbar

ER 16	411010001-55 00675000902	1:1	EK
ER 16	411010002-55 00675000902	1:1	IK 80 bar
ER 11	411007003-55 00675000914	1:2	EK
ER 11	411007004-55 00675000914	1:2	IK 80 bar

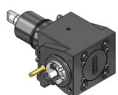

Winkel-Fräseinrichtung für DIN 6358, LF=65

Ø 22	410622013-55 00675000483	1:1	EK
Ø 22	410622007-55 00675000483	2:1	EK

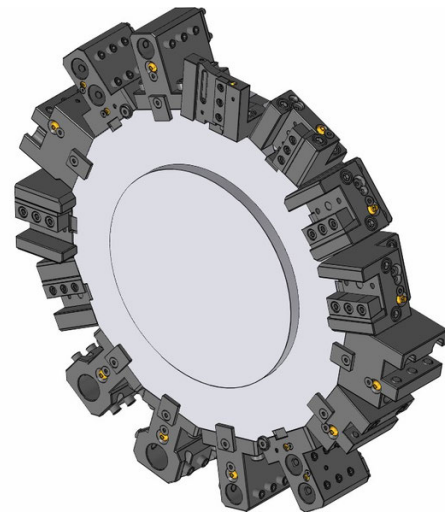
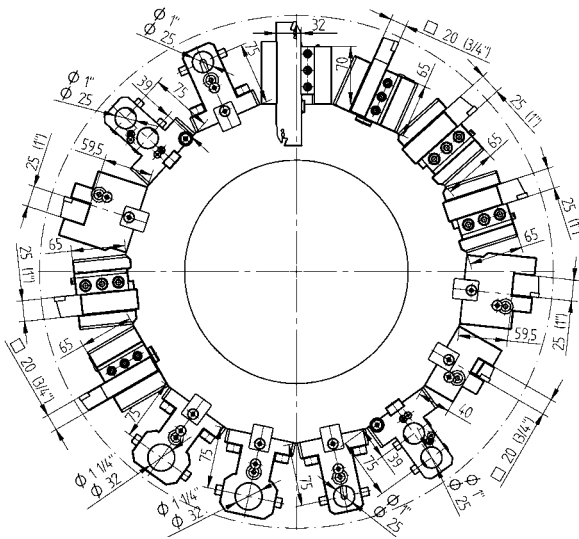

Stehende Werkzeughalter - Standard Programm



20
25

Plan- und Längsdrehhalter

48-108585
48-106720



25

Plan- und Längsdrehhalter, HD-IK

48-106720-HP IK 80 bar



20

Plan- und Längsdrehhalter, beidseitig

48-108460



20

Plandrehhalter

48-108590



25

Plandrehhalter

48-107758

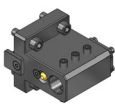

Ø 25
Ø 32

Kombihalter

48-107842 IK 80 bar
48-106727 IK 80 bar

Stehende Werkzeughalter - Erweitertes Programm

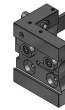

SH 32

Abstechhalter

48-99637



SH 32
SH 32

Abstechhalter, HD-IK

48-102276R IK 80 bar
48-102276L IK 80 bar



SH 32

Abstechhalter, einstellbar

48-110366 EK



SH 32
SH 32

Abstechhalter, einstellbar, HD-IK

48-109656R IK 80 bar
343-810100R87
48-109656L IK 80 bar
343-810100L87

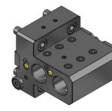

Ø 25

Kombihalter, 2-fach

48-108792 IK 80 bar

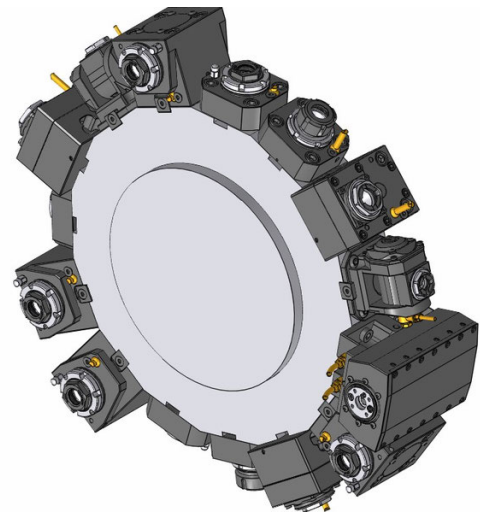
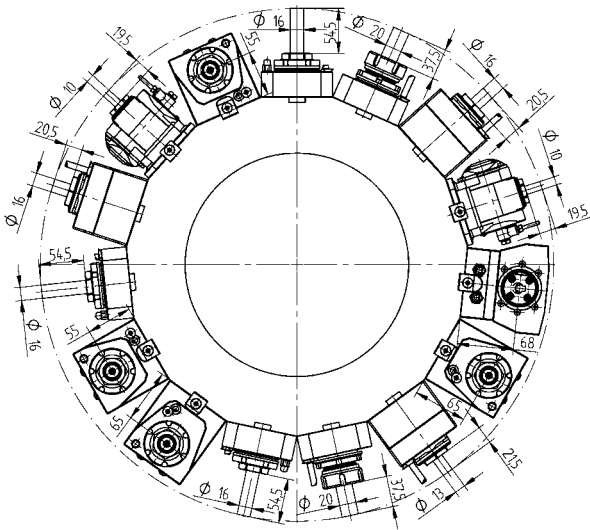

Angetriebene Werkzeughalter - QuickFlex®

Angetriebene Werkzeughalter - Erweitertes Programm



Bohr-Fräseinrichtung - gerade

- ER-25 QF 420125022-55 1:1 EK
 0067725000
- ER-25 QF 420125023-55 1:1 IK 80 bar
 0067725000



Bohr-Fräseinrichtung - gerade

- ER 32 410120002-55 1:1 EK
 0067825000
- ER 32 410120003-55 1:1 IK 80 bar
 0067825000

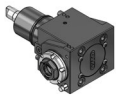

Winkel-Bohr-Fräseinrichtung, LF=55

- ER-25 QF 420525087-55 1:1 EK
 0067725000
- ER-25 QF 420525088-55 1:1 IK 80 bar
 0067725000

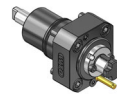

Fräseinrichtung - gerade

- Ø 22 410222002-55 1:1 EK
 00675000483



Winkel-Bohr-Fräseinrichtung, LF=65

- ER-25 QF 420525085-55 1:1 EK
 0067725000
- ER-25 QF 420525086-55 1:1 IK 80 bar
 0067725000



Bohr-Fräseinrichtung - gerade mit Versatz

- ER 25 410116027-55 1:1 EK
 00675000932
- ER 25 410116028-55 1:1 IK 80 bar
 00675000932
- ER 20 410113006-55 1:2 EK
 00675000939
- ER 20 410113004-55 1:2 IK 80 bar
 00675000939
- ER 16 410410000-55 1:3 EK
 00675000937
- ER 16 410410001-55 1:3 IK 80 bar
 00675000937
- ER 25 410116021-55 2:1 EK
 00675000932
- ER 25 410116022-55 2:1 IK 80 bar
 00675000932



Winkel-Bohr-Fräseinrichtung, beidseitig, LF=55

- ER-25 QF 420525069-55 1:1 EK
 0067725000



Winkel-Bohr-Fräseinrichtung, beidseitig, LF=65

- ER-25 QF 420525077-55 1:1 EK
 0067725000

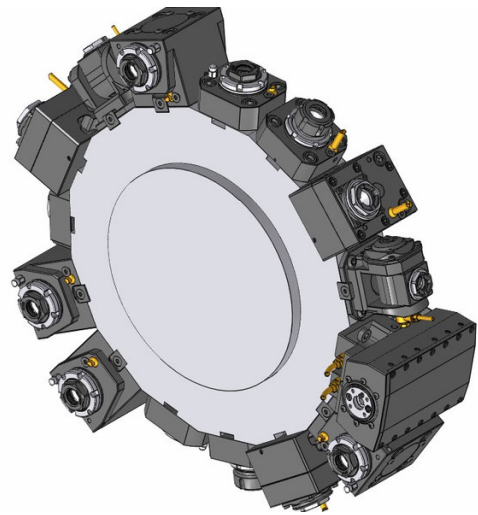
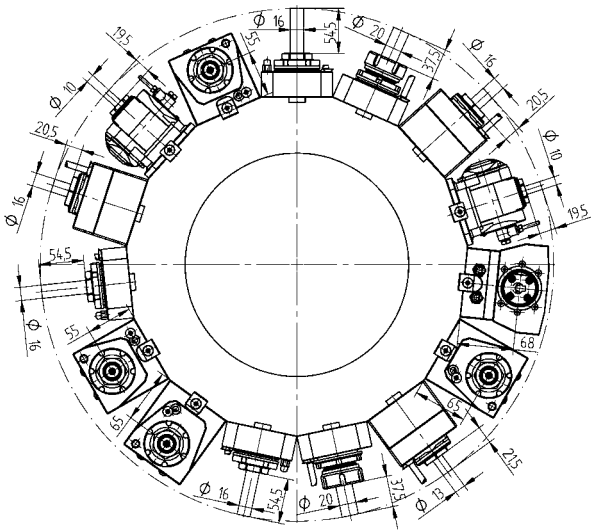

Angetriebene Werkzeughalter - Erweitertes Programm

Angetriebene Werkzeughalter - Erweitertes Programm



Winkel-Bohr-Fräseinrichtung, LF=65

ER 32	410520045-55 0067825000	1:1	EK
ER 32	410520046-55 0067825000	1:1	IK 80 bar
ER-20 QF	420520029-55 0067720001	1:2	EK
ER-20 QF	420520030-55 0067720001	1:2	IK 80 bar
ER 16	410810022-55 00675000841	1:3	EK
ER 16	410810023-55 00675000841	1:3	IK 80 bar
ER-25 QF	420525055-55 0067725000	2:1	EK
ER-25 QF	420525056-55 0067725000	2:1	IK 80 bar



Winkel-Bohr-Fräseinrichtung - zurückgesetzt, LF=65

ER 32	410520007-55 00675000592	1:1	EK
ER 32	410520008-55 00675000592	1:1	IK 80 bar
ER 32	410520009-55 00675000592	2:1	EK
ER 32	410520010-55 00675000592	2:1	IK 80 bar



Bohr-Fräseinrichtung - winkelverstellbar

ER 16	411010001-55 00675000902	1:1	EK
ER 16	411010002-55 00675000902	1:1	IK 80 bar
ER 11	411007003-55 00675000914	1:2	EK
ER 11	411007004-55 00675000914	1:2	IK 80 bar

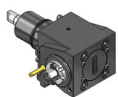

Winkel-Fräseinrichtung für DIN 6358, LF=65

Ø 22	410622013-55 00675000483	1:1	EK
Ø 22	410622007-55 00675000483	2:1	EK

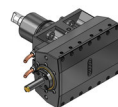

Stoßeinheit für innen und außen

TN765050	414532003-55	1:1	EK
-----------------	--------------	-----	----

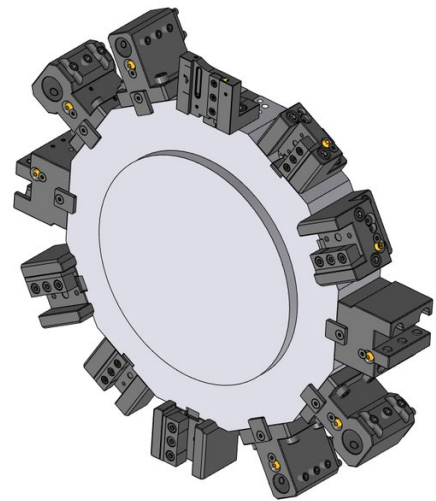
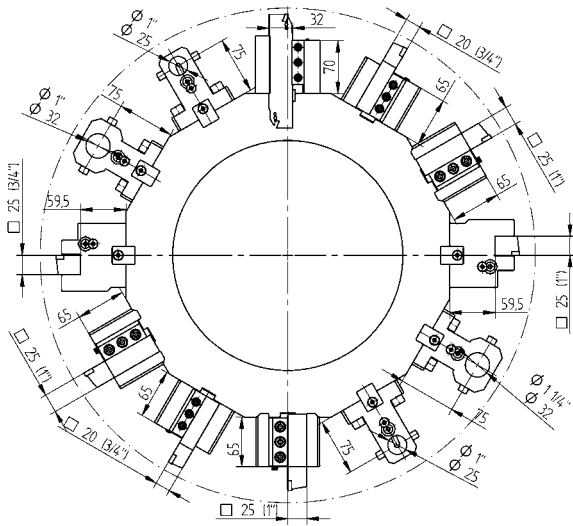

Stehende Werkzeughalter - Standard Programm



Plan- und Längsdrehhalter
 20 48-108585
 25 48-106720



Plan- und Längsdrehhalter, HD-IK
 25 48-106720-HP IK 80 bar



Plandrehhalter
 25 48-107758

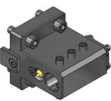

Kombihalter
 Ø 25 48-107842 IK 80 bar
 Ø 32 48-106727 IK 80 bar

Stehende Werkzeughalter - Erweitertes Programm

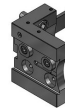

Abstechhalter
 SH 32 48-99637



Abstechhalter, HD-IK
 SH 32 48-102276R IK 80 bar
 SH 32 48-102276L IK 80 bar



Abstechhalter, einstellbar
 SH 32 48-110366 EK



Abstechhalter, einstellbar, HD-IK
 SH 32 48-109656R IK 80 bar
 343-810100R87
 SH 32 48-109656L IK 80 bar
 343-810100L87

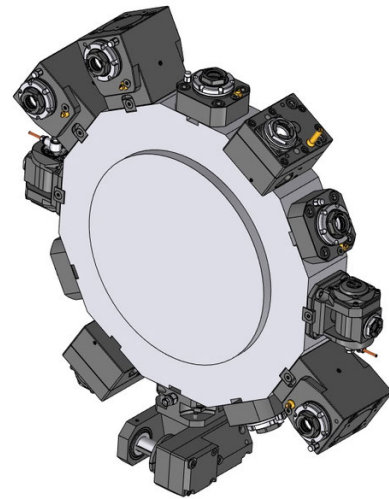
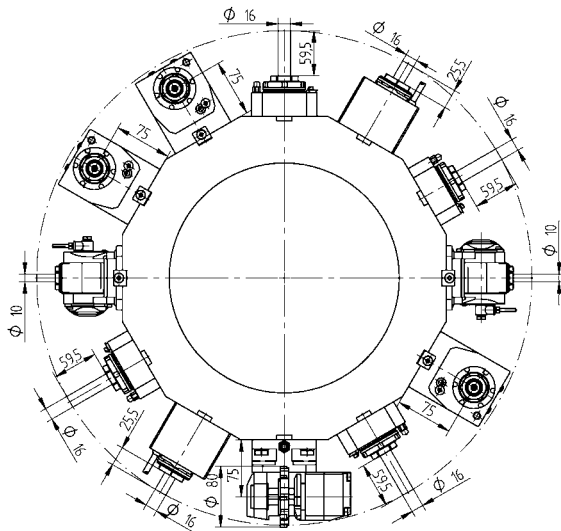

Angetriebene Werkzeughalter - QuickFlex®

Angetriebene Werkzeughalter - Erweitertes Programm



Bohr-Fräseinrichtung - gerade

- ER-25 QF 420125022-55 1:1 EK
 0067725000
- ER-25 QF 420125023-55 1:1 IK 80 bar
 0067725000



Bohr-Fräseinrichtung - gerade

- ER 32 410120002-55 1:1 EK
 0067825000
- ER 32 410120003-55 1:1 IK 80 bar
 0067825000



Winkel-Bohr-Fräseinrichtung, LF=75

- ER-25 QF 420525093-55 1:1 EK
 0067725000
- ER-25 QF 420525094-55 1:1 IK 80 bar
 0067725000

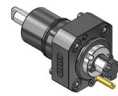

Fräseinrichtung - gerade

- Ø 22 410222002-55 1:1 EK
 00675000483



Bohr-Fräseinrichtung - gerade mit Versatz

- ER 25 410116027-55 1:1 EK
 00675000932
- ER 25 410116028-55 1:1 IK 80 bar
 00675000932
- ER 20 410113006-55 1:2 EK
 00675000939
- ER 20 410113004-55 1:2 IK 80 bar
 00675000939
- ER 16 410410000-55 1:3 EK
 00675000937
- ER 16 410410001-55 1:3 IK 80 bar
 00675000937
- ER 25 410116021-55 2:1 EK
 00675000932
- ER 25 410116022-55 2:1 IK 80 bar
 00675000932

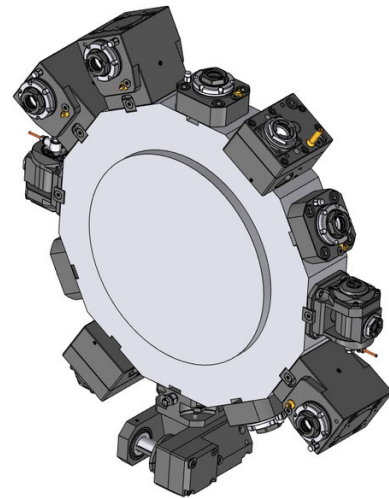
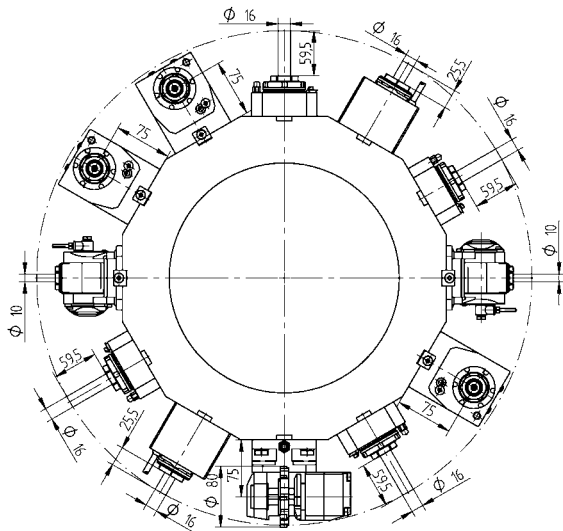

Angetriebene Werkzeughalter - Erweitertes Programm

Angetriebene Werkzeughalter - Erweitertes Programm



Winkel-Bohr-Fräseinrichtung, LF=75

ER-20 QF	420520027-55 0067720001	1:2	EK
ER-20 QF	420520028-55 0067720001	1:2	IK 80 bar
ER 16	410810024-55 00675000841	1:3	EK
ER 16	410810025-55 00675000841	1:3	IK 80 bar
ER 32	410520022-55 00675000592	2:1	EK
ER 32	410520023-55 00675000592	2:1	IK 80 bar

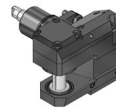

Fräseinrichtung für Scheibenfräser

Typ 14-2	411500000-55 00675000489	2,73:1	EK
	160016142 Ø 16		
	160022142 Ø 22		
	160027142 Ø 27		
	160015142 Ø 5/8"		
	160019142 Ø 3/4"		
	160023142 Ø 7/8"		
	160025142 Ø 1"		

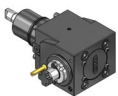

Winkel-Fräseinrichtung für DIN 6358, LF=75

Ø 22	410622014-55 00675000483	1:1	EK
Ø 22	410622008-55 00675000483	2:1	EK



Bohr-Fräseinrichtung - winkelverstellbar

ER 16	411010001-55 00675000902	1:1	EK
ER 16	411010002-55 00675000902	1:1	IK 80 bar
ER 11	411007003-55 00675000914	1:2	EK
ER 11	411007004-55 00675000914	1:2	IK 80 bar

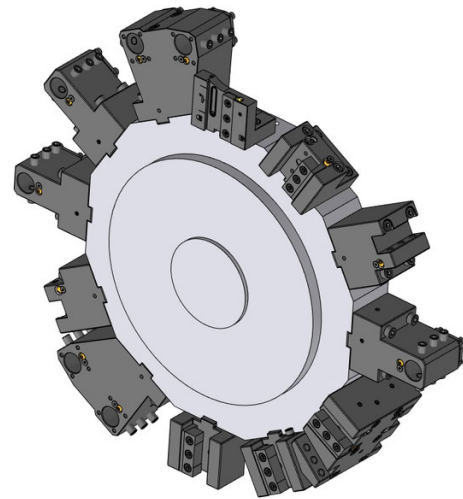
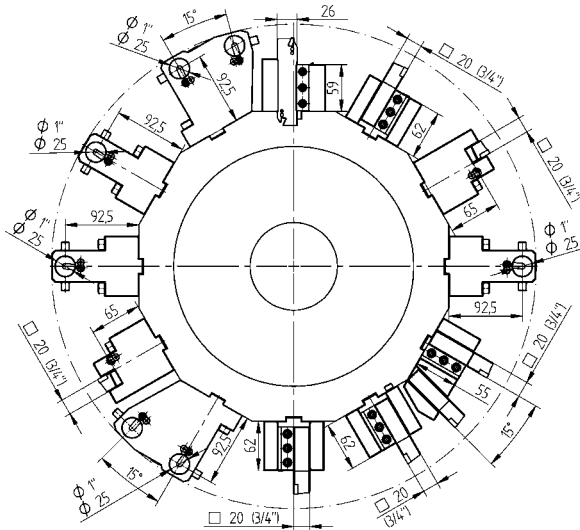

Stehende Werkzeughalter - Standard Programm

Stehende Werkzeughalter - Erweitertes Programm



20

Plan- und Längsdrehhalter

48-101470



20

Plan- und Längsdrehhalter, HD-IK

48-101470-HP IK 80 bar



20

Plan- und Längsdrehhalter, beidseitig

48-101471



20

Plandrehhalter

48-102352



Ø 25

Kombihalter, LF=92,5

48-106613



20

Plan- und Längsdrehhalter, beidseitig, 2-fach, 24 Stationen (nur für Revolver-SW390)

48-114360 EK

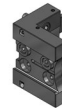

SH 26

Abstechhalter

48-100419

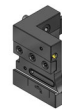

SH 26

Abstechhalter, HD-IK

48-102274R IK 80 bar

SH 26

48-102274L IK 80 bar

SH 32

48-112233R IK 80 bar

343-810100R95

SH 32

48-112233L IK 80 bar

343-810100L95

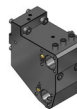

Ø 25

Kombihalter, universal, 2-fach, 24 Stationen (nur für Revolver-SW390)

48-114362 IK 80 bar

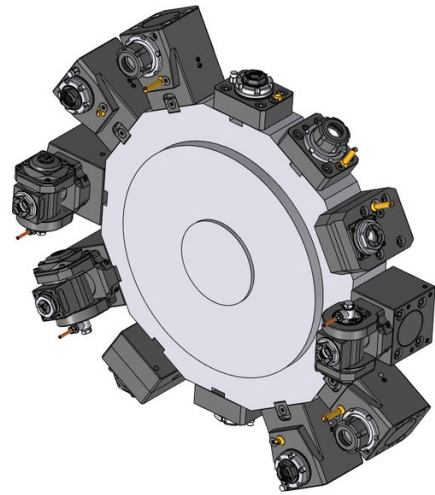
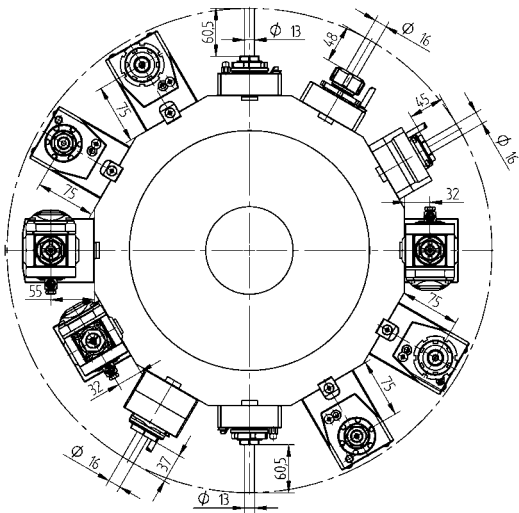

Angetriebene Werkzeughalter - QuickFlex®

Angetriebene Werkzeughalter - Erweitertes Programm



Bohr-Fräseinrichtung - gerade

- ER-20 QF 420120010-44 1:1 EK
 0067720000
- ER-20 QF 420120011-44 1:1 IK 80 bar
 0067720000



Winkel-Bohr-Fräseinrichtung, LF=75

- ER-20 QF 420520015-44 1:1 EK
 0067720000
- ER-20 QF 420520016-44 1:1 IK 80 bar
 0067720000



Bohr-Fräseinrichtung - gerade

- ER 25 410116004-44 1:1 EK
 00675000720
- ER 25 410116002-44 1:1 IK 80 bar
 00675000720



Bohr-Fräseinrichtung - gerade mit Versatz

- ER 20 410113004-44 1:2 EK
 00675000939
- ER 16 410110002-44 1:3 EK
 00675000937
- ER 25 410116005-44 1,5:1 EK
 00675000932



Winkel-Bohr-Fräseinrichtung, LF=75

- ER 25 410516007-44 1:1 EK
 00675000720
- ER 25 410516008-44 1:1 IK 80 bar
 00675000720

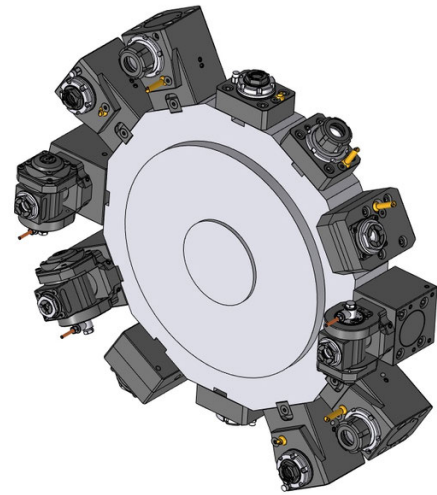
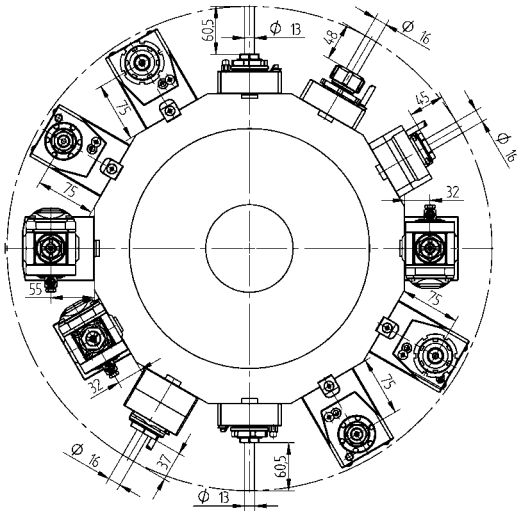

Angetriebene Werkzeughalter - Erweitertes Programm



Bohr-Fräseinrichtung - winkelverstellbar, LF=32

ER 16	411010004-44	1:1	EK
	00675000902		
ER 16	411010005-44	1:1	IK 80 bar
	00675000902		
ER 11	411007006-44	1:2	EK
	00675000914		
ER 11	411007007-44	1:2	IK 80 bar
	00675000914		



Bohr-Fräseinrichtung - winkelverstellbar, LF=55

ER 16	411010007-44	1:1	EK
	00675000902		
ER 16	411010011-44	1:1	IK 80 bar
	00675000902		
ER 11	411007009-44	1:2	EK
	00675000914		
ER 11	411007008-44	1:2	IK 80 bar
	00675000914		

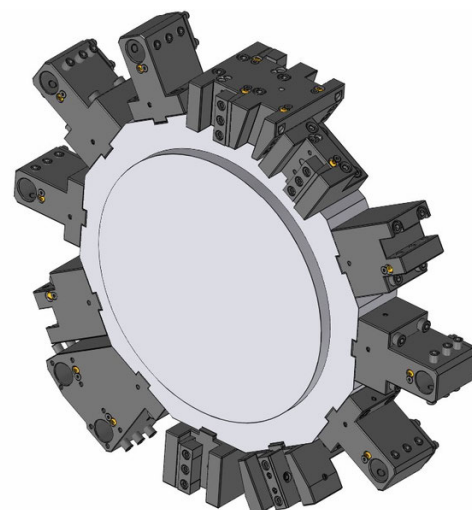
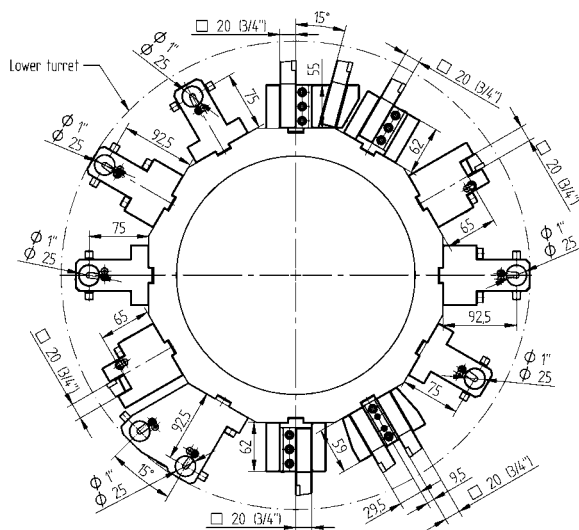

Stehende Werkzeughalter - Standard Programm

Stehende Werkzeughalter - Erweitertes Programm



20

Plan- und Längsdrehhalter

48-101470



20

Plan- und Längsdrehhalter, HD-IK

48-101470-HP IK 80 bar

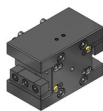

20

Plan- und Längsdrehhalter, beidseitig

48-101471



20

Plandrehhalter

48-102352



Ø 25

Kombihalter, LF=75

48-101472



Ø 25

Kombihalter, LF=92,5

48-106613



20

Plan- und Längsdrehhalter, 2-fach, Y-Achse

48-101473



20

Plan- und Längsdrehhalter, beidseitig, 2-fach, 24 Stationen (nur für Revolver-SW370)

48-108104 EK



SH 26

Abstechhalter

48-100419



SH 26

Abstechhalter, HD-IK

48-102274R IK 80 bar

SH 26

48-102274L IK 80 bar

SH 32

48-112233R IK 80 bar

343-810100R95

SH 32

48-112233L IK 80 bar

343-810100L95



Ø 25

Kombihalter, universal, 2-fach, 24 Stationen (nur für Revolver-SW300)

48-107985 IK 80 bar



Ø 25

Kombihalter, universal, 2-fach, 24 Stationen (nur für Revolver-SW370)

48-108103 IK 80 bar

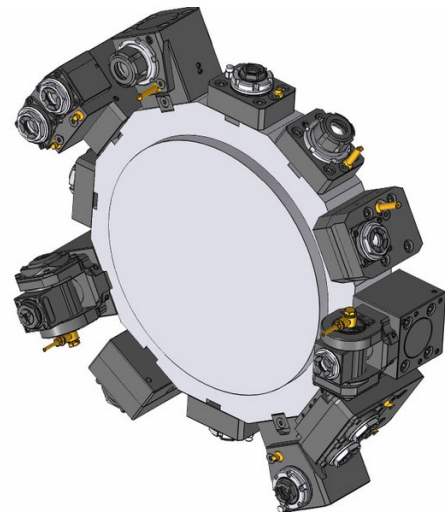
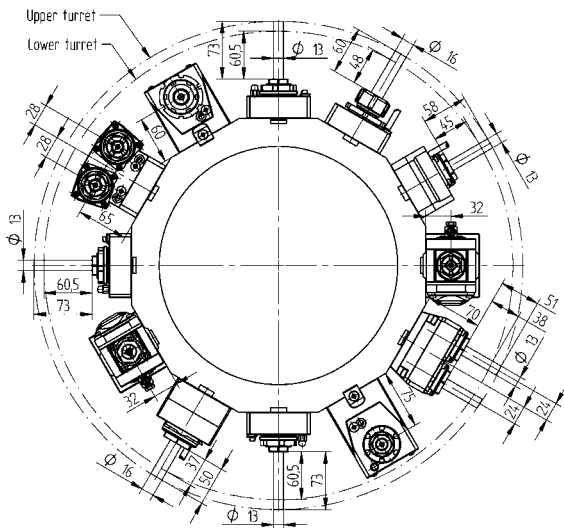

Angetriebene Werkzeughalter - QuickFlex®

Angetriebene Werkzeughalter - Erweitertes Programm



Bohr-Fräseinrichtung - gerade

- ER-20 QF 420120010-44 1:1 EK
 0067720000
- ER-20 QF 420120011-44 1:1 IK 80 bar
 0067720000



Bohr-Fräseinrichtung - gerade

- ER 25 410116004-44 1:1 EK
 00675000720
- ER 25 410116002-44 1:1 IK 80 bar
 00675000720



Winkel-Bohr-Fräseinrichtung, LF=60

- ER-20 QF 420520010-44 1:1 EK
 0067720000
- ER-20 QF 420520011-44 1:1 IK 80 bar
 0067720000

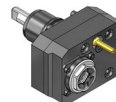

Bohr-Fräseinrichtung - gerade mit Versatz

- ER 20 410113004-44 1:2 EK
 00675000939
- ER 16 410110002-44 1:3 EK
 00675000937
- ER 25 410116005-44 1,5:1 EK
 00675000932



Winkel-Bohr-Fräseinrichtung, LF=75

- ER-20 QF 420520015-44 1:1 EK
 0067720000
- ER-20 QF 420520016-44 1:1 IK 80 bar
 0067720000



Winkel-Bohr-Fräseinrichtung, beidseitig, LF=60

- ER-20 QF 420520012-44 1:1 EK
 0067720000

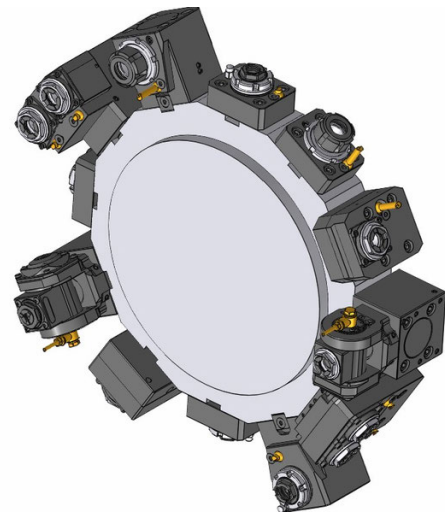
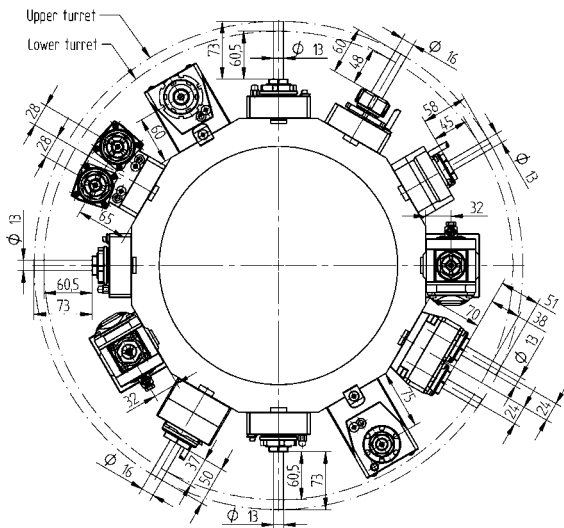

Angetriebene Werkzeughalter - Erweitertes Programm

Angetriebene Werkzeughalter - Erweitertes Programm

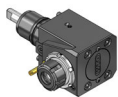

Winkel-Bohr-Fräseinrichtung, LF=60

ER 25	410516005-44 00675000720	1:1	EK
ER 25	410516006-44 00675000720	1:1	IK 80 bar
ER 20	410513002-44 00675000833	1:2	EK
ER 20	410513003-44 00675000833	1:2	IK 80 bar
ER 16	410810006-44 00675000841	1:3	EK
ER 16	410810007-44 00675000841	1:3	IK 80 bar
ER 25	410516002-44 00675000720	2:1	EK
ER 25	410516003-44 00675000720	2:1	IK 80 bar

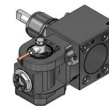

Bohr-Fräseinrichtung - winkelverstellbar, LF=32

ER 16	411010004-44 00675000902	1:1	EK
ER 16	411010005-44 00675000902	1:1	IK 80 bar
ER 11	411007006-44 00675000914	1:2	EK
ER 11	411007007-44 00675000914	1:2	IK 80 bar



Bohr-Fräseinrichtung, 2-fach, Y-Achse

ER 20	413002003-44 00675000939	1:1	EK
ER 20	413002004-44 00675000939	1:1	IK 80 bar

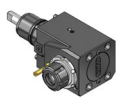

Winkel-Bohr-Fräseinrichtung, LF=75

ER 25	410516007-44 00675000720	1:1	EK
ER 25	410516008-44 00675000720	1:1	IK 80 bar

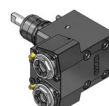

2-Spindel - Winkel-Bohr-Fräseinrichtung, Y-Achse

ER 20	413502004-44 00675000939	1:1	EK
ER 20	413502005-44 00675000939	1:1	IK 80 bar

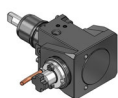

Winkel-Fräseinrichtung für DIN 6358, LF=60

Ø 22	410622000-44 00675000483	1:1	EK
Ø 22	410622001-44 00675000483	2:1	EK

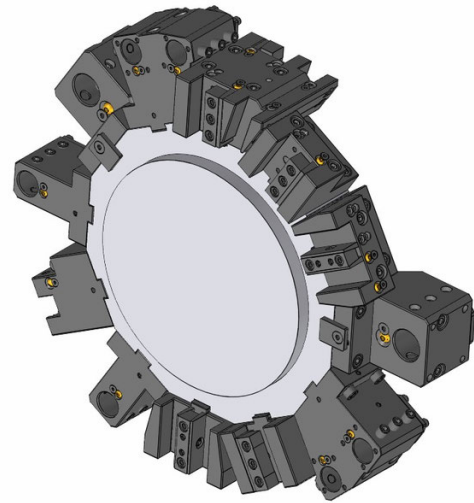
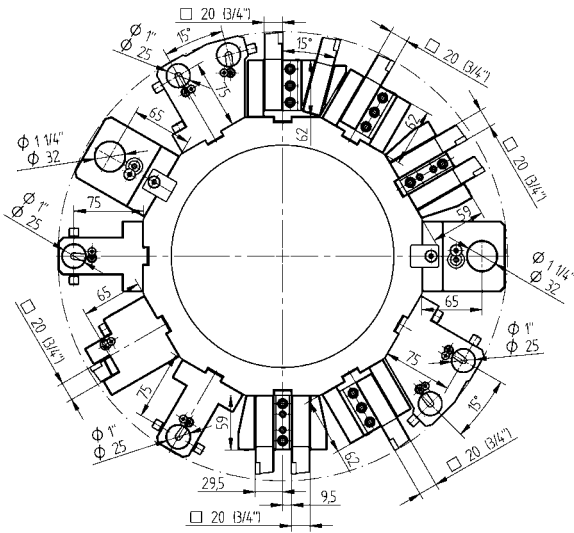

Stehende Werkzeughalter - Standard Programm

Stehende Werkzeughalter - Erweitertes Programm



Plan- und Längsdrehhalter

20 48-101470



Plan- und Längsdrehhalter, HD-IK

20 48-101470-HP IK 80 bar



Plan- und Längsdrehhalter, beidseitig

20 48-101471



Plandrehhalter

20 48-102352



Kombihalter, LF=75

Ø 25 48-101472



Kombihalter

Ø 32 48-107155



Plan- und Längsdrehhalter, 2-fach, Y-Achse

20 48-101473



Plan- und Längsdrehhalter, beidseitig, 2-fach, 24 Stationen (nur für Revolver-SW300)

20 48-107973 EK



Abstechhalter

SH 26 48-100419



Abstechhalter, HD-IK

SH 26 48-102274R IK 80 bar

SH 26 48-102274L IK 80 bar

SH 32 48-112233R IK 80 bar

343-810100R95

SH 32 48-112233L IK 80 bar

343-810100L95



Kombihalter, universal, 2-fach, 24 Stationen (nur für Revolver-SW300)

Ø 25 48-107985 IK 80 bar

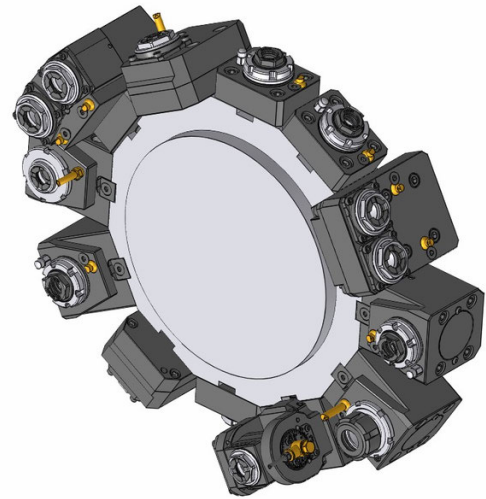
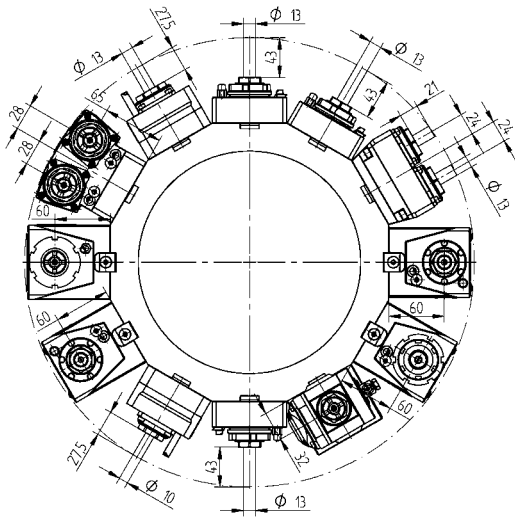

Angetriebene Werkzeughalter - QuickFlex®

Angetriebene Werkzeughalter - QuickFlex®



Bohr-Fräseinrichtung - gerade

- ER-20 QF 420120010-44 1:1 EK
 0067720000
- ER-20 QF 420120011-44 1:1 IK 80 bar
 0067720000



Winkel-Bohr-Fräseinrichtung, beidseitig, LF=60

- ER-20 QF 420520012-44 1:1 EK
 0067720000



Bohr-Fräseinrichtung - gerade (8000 1/min)

- ER-20 QF 420120010-44-S 1:1 EK
 0067720000
- ER-20 QF 420120011-44-S 1:1 IK 80 bar
 0067720000



Winkel-Bohr-Fräseinrichtung, LF=60

- ER-20 QF 420520010-44 1:1 EK
 0067720000
- ER-20 QF 420520011-44 1:1 IK 80 bar
 0067720000



Winkel-Bohr-Fräseinrichtung, LF=60, (8000 1/min)

- ER-20 QF 420520010-44-S 1:1 EK
 0067720000
- ER-20 QF 420520011-44-S 1:1 IK 80 bar
 0067720000

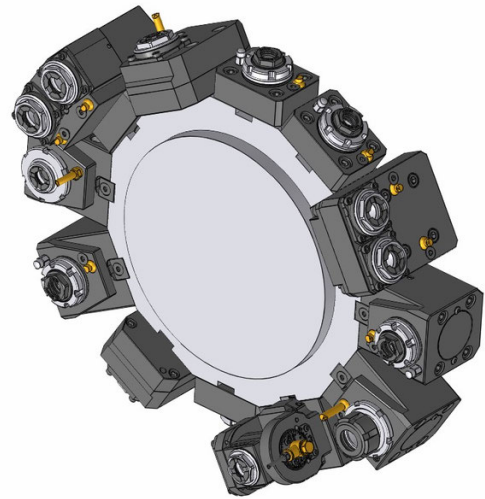
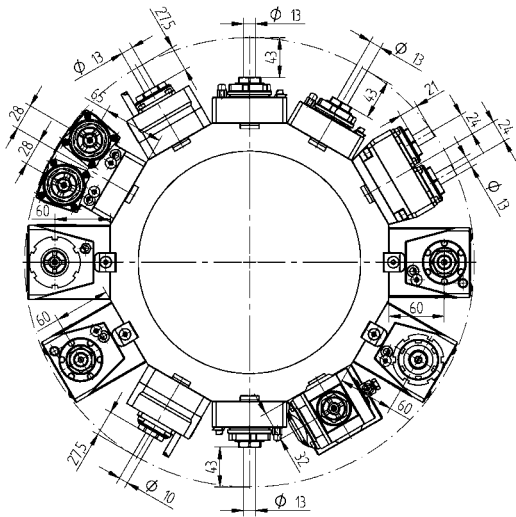

Angetriebene Werkzeughalter - Erweitertes Programm

Angetriebene Werkzeughalter - Erweitertes Programm



Bohr-Fräseinrichtung - gerade

- | | | | |
|--------------|-----------------------------|-----|-----------|
| ER 25 | 410116004-44
00675000720 | 1:1 | EK |
| ER 25 | 410116002-44
00675000720 | 1:1 | IK 80 bar |



Bohr-Fräseinrichtung - gerade (8000 1/min)

- | | | | |
|--------------|-------------------------------|-----|-----------|
| ER 25 | 410116004-44-S
00675000720 | 1:1 | EK |
| ER 25 | 410116002-44-S
00675000720 | 1:1 | IK 80 bar |



Bohr-Fräseinrichtung - gerade mit Versatz

- | | | | |
|--------------|-----------------------------|-------|----|
| ER 20 | 410113004-44
00675000939 | 1:2 | EK |
| ER 16 | 410110002-44
00675000937 | 1:3 | EK |
| ER 25 | 410116005-44
00675000932 | 1,5:1 | EK |



Winkel-Bohr-Fräseinrichtung, LF=60

- | | | | |
|--------------|-----------------------------|-----|-----------|
| ER 25 | 410516005-44
00675000720 | 1:1 | EK |
| ER 25 | 410516006-44
00675000720 | 1:1 | IK 80 bar |
| ER 20 | 410513002-44
00675000833 | 1:2 | EK |
| ER 20 | 410513003-44
00675000833 | 1:2 | IK 80 bar |
| ER 16 | 410810006-44
00675000841 | 1:3 | EK |
| ER 16 | 410810007-44
00675000841 | 1:3 | IK 80 bar |
| ER 25 | 410516002-44
00675000720 | 2:1 | EK |
| ER 25 | 410516003-44
00675000720 | 2:1 | IK 80 bar |



Winkel-Bohr-Fräseinrichtung, LF=60, (8000 1/min)

- | | | | |
|--------------|-------------------------------|-----|-----------|
| ER 25 | 410516005-44-S
00675000720 | 1:1 | EK |
| ER 25 | 410516006-44-S
00675000720 | 1:1 | IK 80 bar |

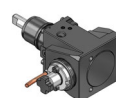

Winkel-Fräseinrichtung für DIN 6358, LF=60

- | | | | |
|-------------|-----------------------------|-----|----|
| Ø 22 | 410622000-44
00675000483 | 1:1 | EK |
| Ø 22 | 410622001-44
00675000483 | 2:1 | EK |

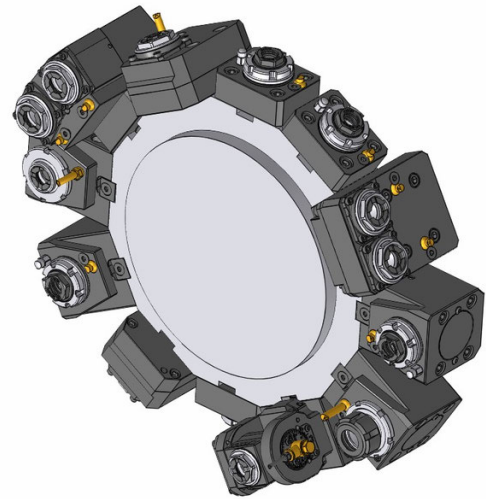
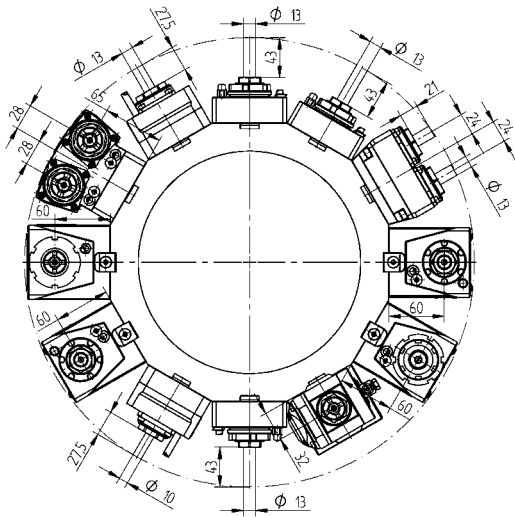

Angetriebene Werkzeughalter - Erweitertes Programm

Angetriebene Werkzeughalter - Erweitertes Programm



Bohr-Fräseinrichtung - winkelverstellbar, LF=32

ER 16	411010004-44	1:1	EK
	☞ 00675000902		
ER 16	411010005-44	1:1	IK 80 bar
	☞ 00675000902		
ER 11	411007006-44	1:2	EK
	☞ 00675000914		
ER 11	411007007-44	1:2	IK 80 bar
	☞ 00675000914		

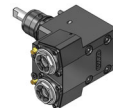

2-Spindel - Winkel-Bohr-Fräseinrichtung, Y-Achse

ER 20	413502004-44	1:1	EK
	☞ 00675000939		
ER 20	413502005-44	1:1	IK 80 bar
	☞ 00675000939		



Bohr-Fräseinrichtung - winkelverstellbar, LF=55

ER 16	411010007-44	1:1	EK
	☞ 00675000902		
ER 16	411010011-44	1:1	IK 80 bar
	☞ 00675000902		
ER 11	411007009-44	1:2	EK
	☞ 00675000914		
ER 11	411007008-44	1:2	IK 80 bar
	☞ 00675000914		



Bohr-Fräseinrichtung, 2-fach, Y-Achse

ER 20	413002003-44	1:1	EK
	☞ 00675000939		
ER 20	413002004-44	1:1	IK 80 bar
	☞ 00675000939		

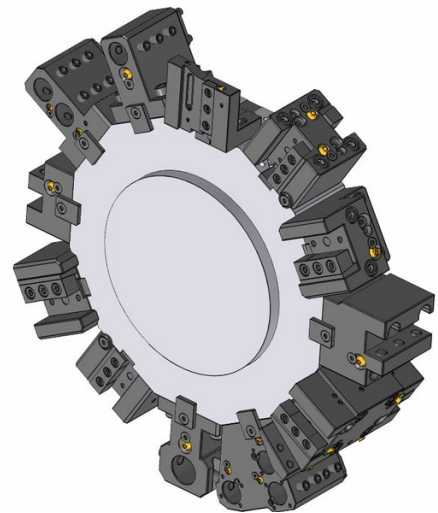
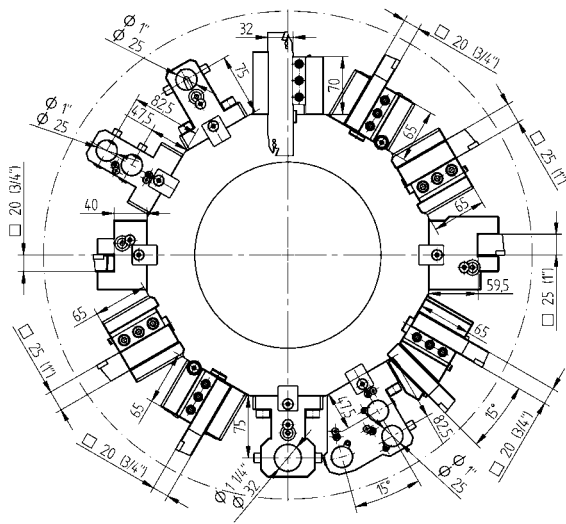

Stehende Werkzeughalter - Standard Programm

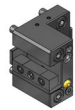

20
25

Plan- und Längsdrehhalter

48-108585
48-106720



25

Plan- und Längsdrehhalter, HD-IK

48-106720-HP IK 80 bar



20

Plan- und Längsdrehhalter, beidseitig

48-108460



20

Plandrehhalter

48-108590



25

Plandrehhalter

48-107758



Ø 25
Ø 32

Kombihalter

48-107842 IK 80 bar
48-106727 IK 80 bar

Stehende Werkzeughalter - Erweitertes Programm



20

Plan- und Längsdrehhalter, 2-fach, 24 Stationen (nur für Revolver-SW340)

48-108592 EK



20

Plan- und Längsdrehhalter, beidseitig, 2-fach, 24 Stationen (nur für Revolver-SW340)

48-108461 EK

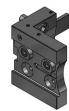

SH 32

Abstechhalter

48-99637



SH 32
SH 32

Abstechhalter, HD-IK

48-102276R IK 80 bar
48-102276L IK 80 bar



SH 32
SH 32

Abstechhalter, einstellbar, HD-IK

48-109656R IK 80 bar
343-810100R87
48-109656L IK 80 bar
343-810100L87

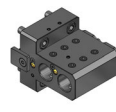

Ø 25

Kombihalter, 2-fach

48-108596 IK 80 bar

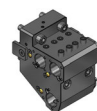

Ø 25

Kombihalter, universal, 3-fach, 24 Stationen (nur für Revolver-SW340)

48-108462 IK 80 bar

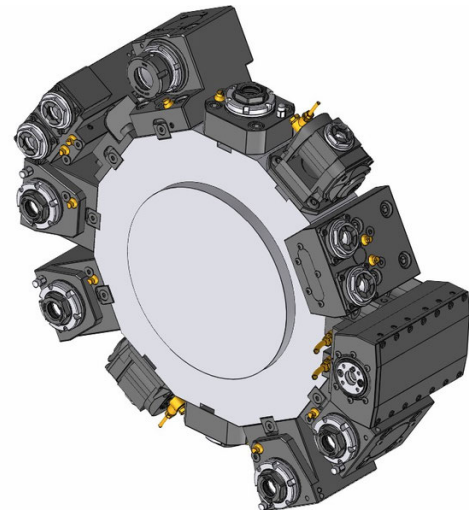
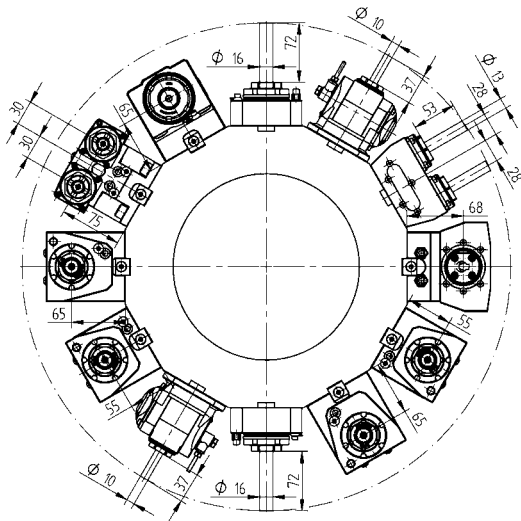

Angetriebene Werkzeughalter - QuickFlex®

Angetriebene Werkzeughalter - Erweitertes Programm



Bohr-Fräseinrichtung - gerade

- ER-25 QF 420125022-55 1:1 EK
0067725000
- ER-25 QF 420125023-55 1:1 IK 80 bar
0067725000



Bohr-Fräseinrichtung - gerade

- ER 32 410120002-55 1:1 EK
0067825000
- ER 32 410120003-55 1:1 IK 80 bar
0067825000

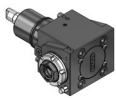

Winkel-Bohr-Fräseinrichtung, LF=55

- ER-25 QF 420525087-55 1:1 EK
0067725000
- ER-25 QF 420525088-55 1:1 IK 80 bar
0067725000

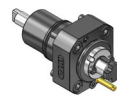

Fräseinrichtung - gerade

- Ø 22 410222002-55 1:1 EK
00675000483

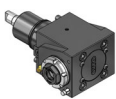

Winkel-Bohr-Fräseinrichtung, LF=65

- ER-25 QF 420525085-55 1:1 EK
0067725000
- ER-25 QF 420525086-55 1:1 IK 80 bar
0067725000



Bohr-Fräseinrichtung - gerade mit Versatz

- ER 25 410116027-55 1:1 EK
00675000932
- ER 25 410116028-55 1:1 IK 80 bar
00675000932
- ER 20 410113006-55 1:2 EK
00675000939
- ER 20 410113004-55 1:2 IK 80 bar
00675000939
- ER 16 410410000-55 1:3 EK
00675000937
- ER 16 410410001-55 1:3 IK 80 bar
00675000937
- ER 25 410116021-55 2:1 EK
00675000932
- ER 25 410116022-55 2:1 IK 80 bar
00675000932



Winkel-Bohr-Fräseinrichtung, beidseitig, LF=55

- ER-25 QF 420525069-55 1:1 EK
0067725000



Winkel-Bohr-Fräseinrichtung, beidseitig, LF=65

- ER-25 QF 420525077-55 1:1 EK
0067725000

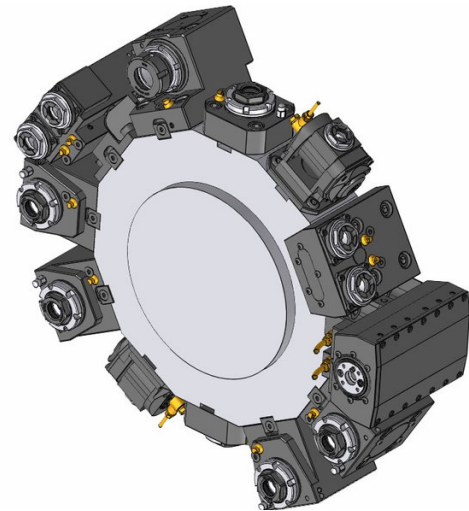
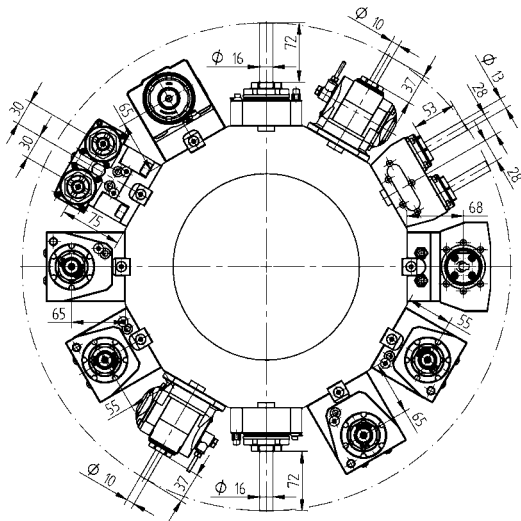

Angetriebene Werkzeughalter - Erweitertes Programm

Angetriebene Werkzeughalter - Erweitertes Programm



Winkel-Bohr-Fräseinrichtung, LF=65

ER 32	410520045-55 0067825000	1:1	EK
ER 32	410520046-55 0067825000	1:1	IK 80 bar
ER-20 QF	420520029-55 0067720001	1:2	EK
ER-20 QF	420520030-55 0067720001	1:2	IK 80 bar
ER 16	410810022-55 00675000841	1:3	EK
ER 16	410810023-55 00675000841	1:3	IK 80 bar
ER-25 QF	420525055-55 0067725000	2:1	EK
ER-25 QF	420525056-55 0067725000	2:1	IK 80 bar

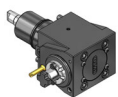

Winkel-Fräseinrichtung für DIN 6358, LF=65

Ø 22	410622013-55 00675000483	1:1	EK
Ø 22	410622007-55 00675000483	2:1	EK



Winkel-Bohr-Fräseinrichtung - zurückgesetzt, LF=65

ER 32	410520007-55 00675000592	1:1	EK
ER 32	410520008-55 00675000592	1:1	IK 80 bar
ER 32	410520009-55 00675000592	2:1	EK
ER 32	410520010-55 00675000592	2:1	IK 80 bar



Bohr-Fräseinrichtung - winkelverstellbar

ER 16	411010001-55 00675000902	1:1	EK
ER 16	411010002-55 00675000902	1:1	IK 80 bar
ER 11	411007003-55 00675000914	1:2	EK
ER 11	411007004-55 00675000914	1:2	IK 80 bar

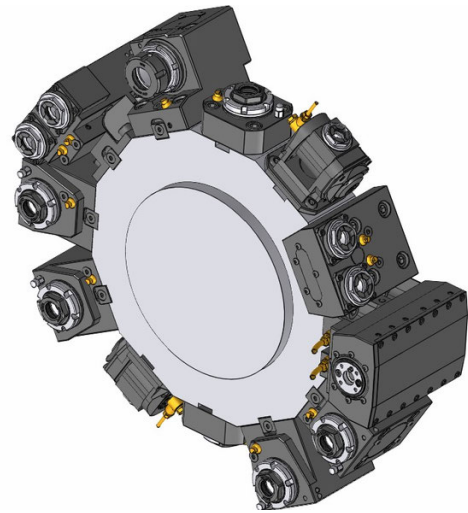
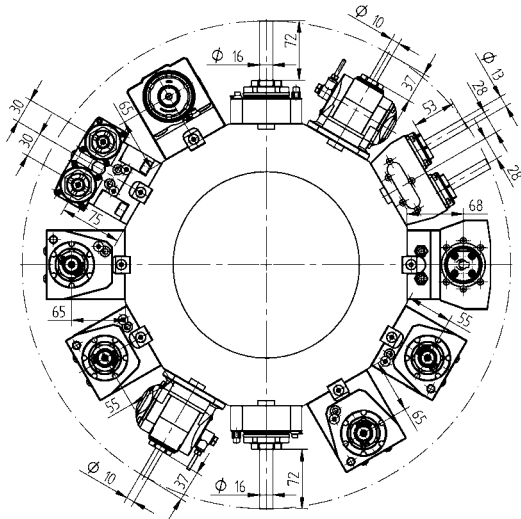

Angetriebene Werkzeughalter - Erweitertes Programm

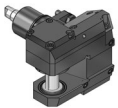

Typ 14-2

Fräseinrichtung für Scheibenfräser

411500000-55 2,73:1 EK

00675000489

160016142 Ø 16

160022142 Ø 22

160027142 Ø 27

160015142 Ø 5/8"

160019142 Ø 3/4"

160023142 Ø 7/8"

160025142 Ø 1"



ER 20

Bohr-Fräseinrichtung, 2-fach, Y-Achse

413002001-55 1:1 EK

00675000944

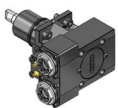

ER 20

2-Spindel - Winkel-Bohr-Fräseinrichtung, Y-Achse

413502012-55 1:1 EK

00675000944

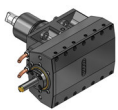

TN765050

Stoßeinheit für innen und außen

414532003-55 1:1 EK

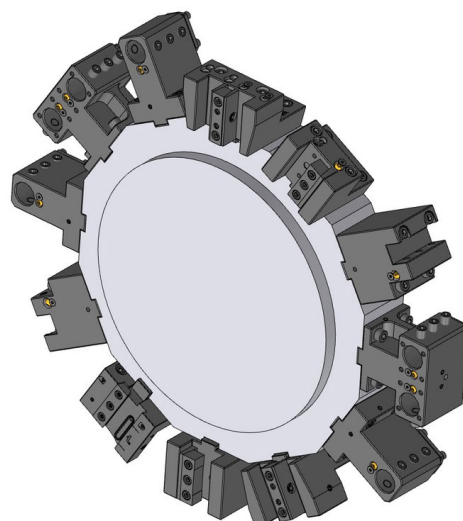
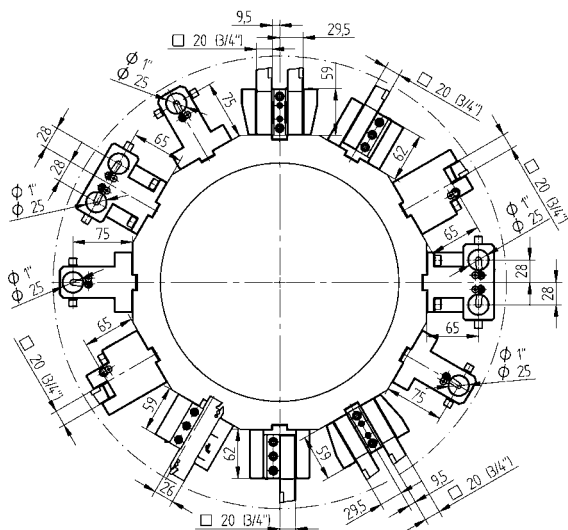

Stehende Werkzeughalter - Standard Programm

Stehende Werkzeughalter - Erweitertes Programm



20

Plan- und Längsdrehhalter

48-101470



20

Plan- und Längsdrehhalter, HD-IK

48-101470-HP IK 80 bar

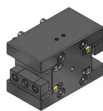

20

Plan- und Längsdrehhalter, beidseitig

48-101471



20

Plandrehhalter

48-102352



Ø 25

Kombihalter, LF=75

48-101472



20

Plan- und Längsdrehhalter, 2-fach, Y-Achse

48-101473



SH 26

Abstechhalter

48-100419



SH 26

Abstechhalter, HD-IK

48-102274R

IK 80 bar

SH 26

48-102274L

IK 80 bar

SH 32

48-112233R
343-810100R95

IK 80 bar

SH 32

48-112233L
343-810100L95

IK 80 bar

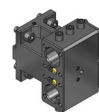

Ø 25

Kombihalter, universal, 2-fach, Y-Achse

48-101474

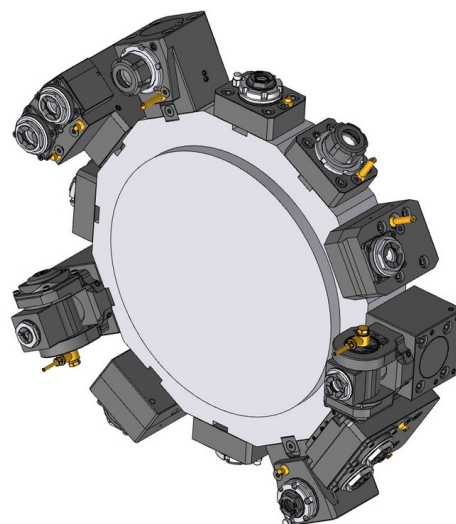
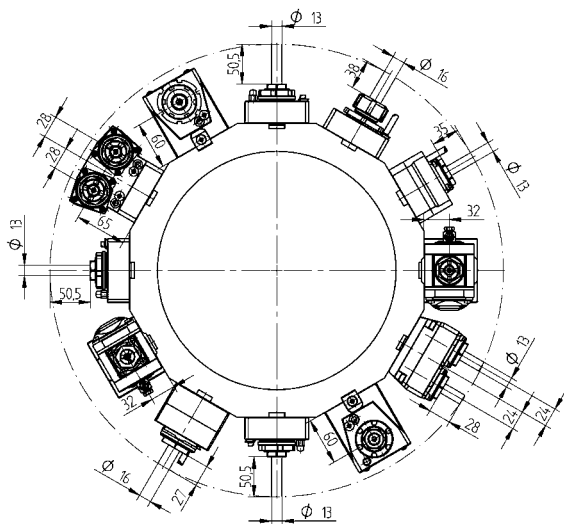

Angetriebene Werkzeughalter - QuickFlex®

Angetriebene Werkzeughalter - Erweitertes Programm



Bohr-Fräseinrichtung - gerade

- ER-20 QF 420120010-44 1:1 EK
 0067720000
- ER-20 QF 420120011-44 1:1 IK 80 bar
 0067720000



Bohr-Fräseinrichtung - gerade

- ER 25 410116004-44 1:1 EK
 00675000720
- ER 25 410116002-44 1:1 IK 80 bar
 00675000720



Winkel-Bohr-Fräseinrichtung, LF=60

- ER-20 QF 420520010-44 1:1 EK
 0067720000
- ER-20 QF 420520011-44 1:1 IK 80 bar
 0067720000



Bohr-Fräseinrichtung - gerade mit Versatz

- ER 20 410113004-44 1:2 EK
 00675000939
- ER 16 410110002-44 1:3 EK
 00675000937
- ER 25 410116005-44 1,5:1 EK
 00675000932



Winkel-Bohr-Fräseinrichtung, LF=75

- ER-20 QF 420520015-44 1:1 EK
 0067720000
- ER-20 QF 420520016-44 1:1 IK 80 bar
 0067720000

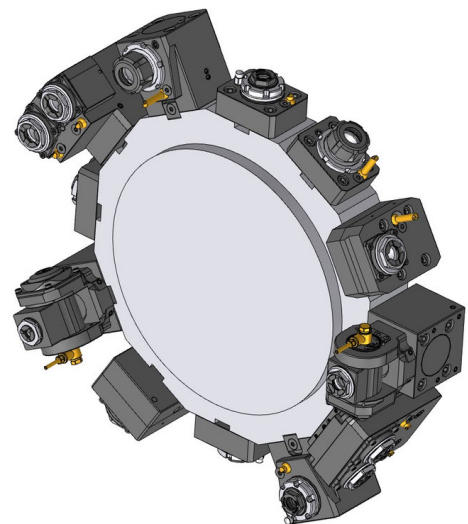
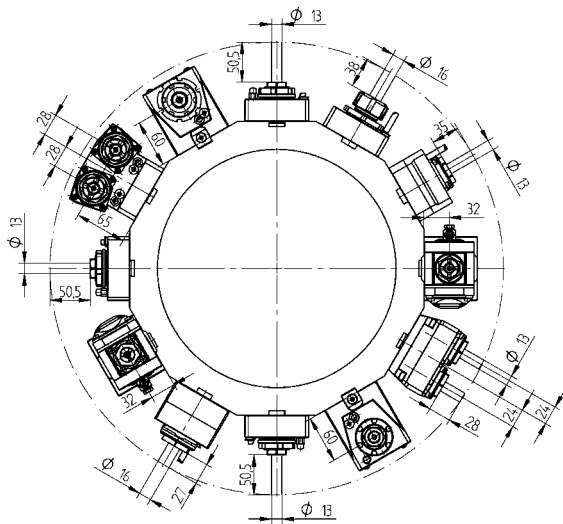

Angetriebene Werkzeughalter - Erweitertes Programm

Angetriebene Werkzeughalter - Erweitertes Programm



Winkel-Bohr-Fräseinrichtung, LF=60

ER 25	410516005-44 00675000720	1:1	EK
ER 25	410516006-44 00675000720	1:1	IK 80 bar
ER 20	410513002-44 00675000833	1:2	EK
ER 20	410513003-44 00675000833	1:2	IK 80 bar
ER 16	410810006-44 00675000841	1:3	EK
ER 16	410810007-44 00675000841	1:3	IK 80 bar
ER 25	410516002-44 00675000720	2:1	EK
ER 25	410516003-44 00675000720	2:1	IK 80 bar

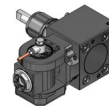

Bohr-Fräseinrichtung - winkelverstellbar, LF=32

ER 16	411010004-44 00675000902	1:1	EK
ER 16	411010005-44 00675000902	1:1	IK 80 bar
ER 11	411007006-44 00675000914	1:2	EK
ER 11	411007007-44 00675000914	1:2	IK 80 bar



Bohr-Fräseinrichtung, 2-fach, Y-Achse

ER 20	413002003-44 00675000939	1:1	EK
ER 20	413002004-44 00675000939	1:1	IK 80 bar

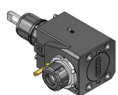

Winkel-Bohr-Fräseinrichtung, LF=75

ER 25	410516007-44 00675000720	1:1	EK
ER 25	410516008-44 00675000720	1:1	IK 80 bar

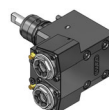

2-Spindel - Winkel-Bohr-Fräseinrichtung, Y-Achse

ER 20	413502004-44 00675000939	1:1	EK
ER 20	413502005-44 00675000939	1:1	IK 80 bar

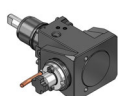

Winkel-Fräseinrichtung für DIN 6358, LF=60

Ø 22	410622000-44 00675000483	1:1	EK
Ø 22	410622001-44 00675000483	2:1	EK

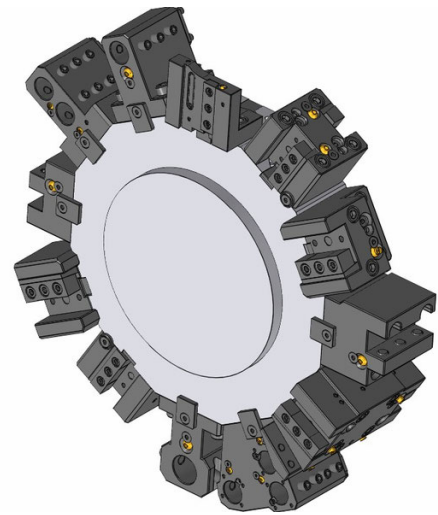
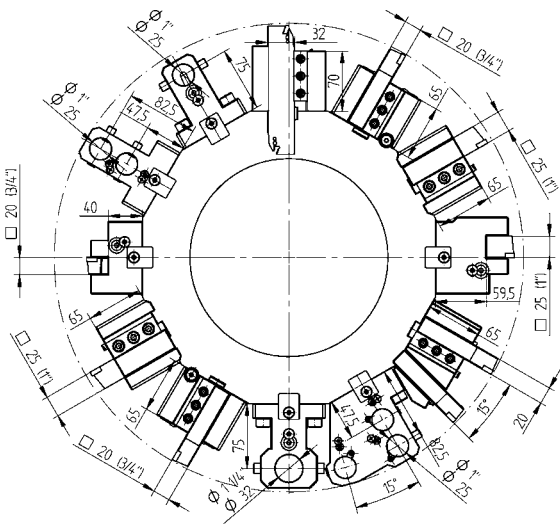

Stehende Werkzeughalter - Standard Programm

Stehende Werkzeughalter - Erweitertes Programm



20
25

Plan- und Längsdrehhalter

48-108585
48-106720



25

Plan- und Längsdrehhalter, HD-IK

48-106720-HP IK 80 bar



20

Plan- und Längsdrehhalter, beidseitig

48-108460



20

Plandrehhalter

48-108590



25

Plandrehhalter

48-107758

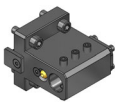

Ø 25
Ø 32

Kombihalter

48-107842 IK 80 bar
48-106727 IK 80 bar



20

Plan- und Längsdrehhalter, 2-fach, 24 Stationen (nur für Revolver-SW340)

48-108592 EK



20

Plan- und Längsdrehhalter, beidseitig, 2-fach, 24 Stationen (nur für Revolver-SW340)

48-108461 EK

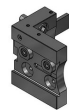

SH 32

Abstechhalter

48-99637



SH 32
SH 32

Abstechhalter, HD-IK

48-102276R IK 80 bar
48-102276L IK 80 bar



SH 32
SH 32

Abstechhalter, einstellbar, HD-IK

48-109656R IK 80 bar
343-810100R87
48-109656L IK 80 bar
343-810100L87

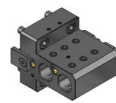

Ø 25

Kombihalter, 2-fach

48-108596 IK 80 bar

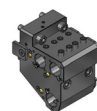

Ø 25

Kombihalter, universal, 3-fach, 24 Stationen (nur für Revolver-SW340)

48-108462 IK 80 bar

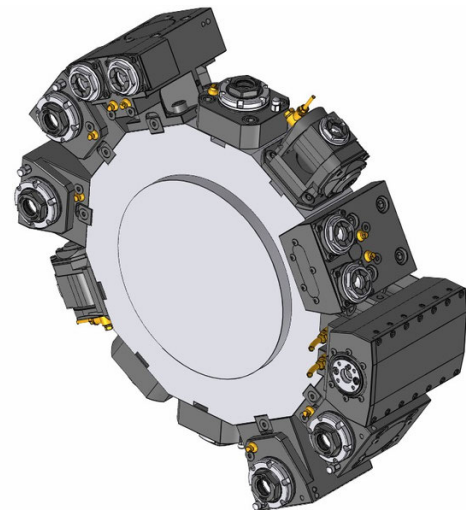
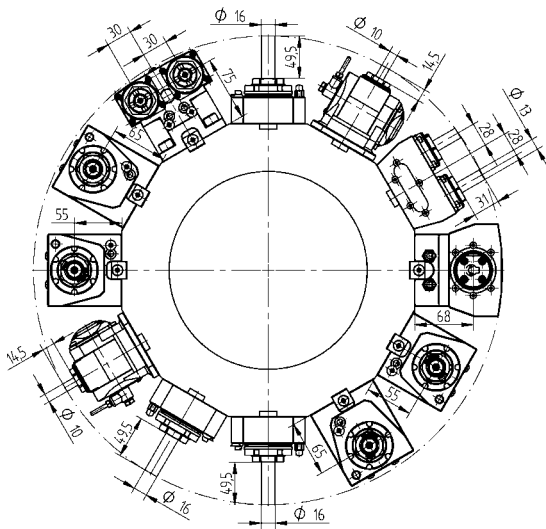

Angetriebene Werkzeughalter - QuickFlex®

Angetriebene Werkzeughalter - Erweitertes Programm



Bohr-Fräseinrichtung - gerade

- ER-25 QF 420125022-55 1:1 EK
 0067725000
- ER-25 QF 420125023-55 1:1 IK 80 bar
 0067725000

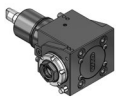

Winkel-Bohr-Fräseinrichtung, LF=55

- ER-25 QF 420525087-55 1:1 EK
 0067725000
- ER-25 QF 420525088-55 1:1 IK 80 bar
 0067725000



Winkel-Bohr-Fräseinrichtung, LF=65

- ER-25 QF 420525085-55 1:1 EK
 0067725000
- ER-25 QF 420525086-55 1:1 IK 80 bar
 0067725000



Winkel-Bohr-Fräseinrichtung, beidseitig, LF=55

- ER-25 QF 420525069-55 1:1 EK
 0067725000



Winkel-Bohr-Fräseinrichtung, beidseitig, LF=65

- ER-25 QF 420525077-55 1:1 EK
 0067725000



Bohr-Fräseinrichtung - gerade

- ER 32 410120002-55 1:1 EK
 0067825000
- ER 32 410120003-55 1:1 IK 80 bar
 0067825000

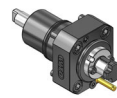

Fräseinrichtung - gerade

- Ø 22 410222002-55 1:1 EK
 00675000483



Bohr-Fräseinrichtung - gerade mit Versatz

- ER 25 410116027-55 1:1 EK
 00675000932
- ER 25 410116028-55 1:1 IK 80 bar
 00675000932
- ER 20 410113006-55 1:2 EK
 00675000939
- ER 20 410113004-55 1:2 IK 80 bar
 00675000939
- ER 16 410410000-55 1:3 EK
 00675000937
- ER 16 410410001-55 1:3 IK 80 bar
 00675000937
- ER 25 410116021-55 2:1 EK
 00675000932
- ER 25 410116022-55 2:1 IK 80 bar
 00675000932

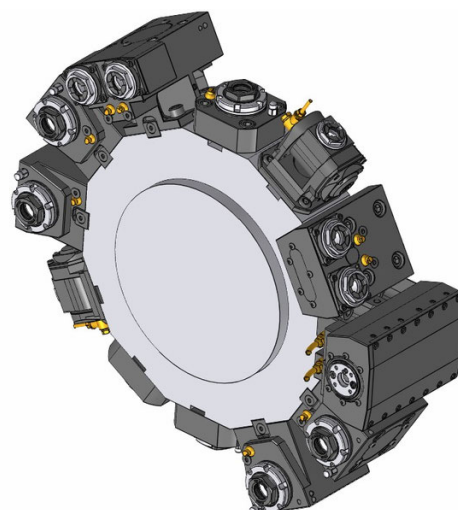
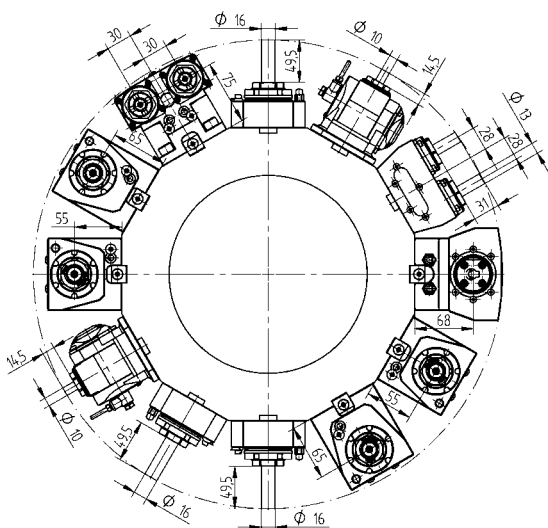

Angetriebene Werkzeughalter - Erweitertes Programm

Angetriebene Werkzeughalter - Erweitertes Programm



Winkel-Bohr-Fräseinrichtung, LF=65

ER 32	410520045-55 0067825000	1:1	EK
ER 32	410520046-55 0067825000	1:1	IK 80 bar
ER-20 QF	420520029-55 0067720001	1:2	EK
ER-20 QF	420520030-55 0067720001	1:2	IK 80 bar
ER 16	410810022-55 00675000841	1:3	EK
ER 16	410810023-55 00675000841	1:3	IK 80 bar
ER-25 QF	420525055-55 0067725000	2:1	EK
ER-25 QF	420525056-55 0067725000	2:1	IK 80 bar

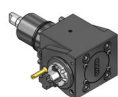

Winkel-Fräseinrichtung für DIN 6358, LF=65

Ø 22	410622013-55 00675000483	1:1	EK
Ø 22	410622007-55 00675000483	2:1	EK

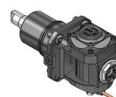

Bohr-Fräseinrichtung - winkelverstellbar

ER 16	411010001-55 00675000902	1:1	EK
ER 16	411010002-55 00675000902	1:1	IK 80 bar
ER 11	411007003-55 00675000914	1:2	EK
ER 11	411007004-55 00675000914	1:2	IK 80 bar



Bohr-Fräseinrichtung, 2-fach, Y-Achse

ER 20	413002001-55 00675000944	1:1	EK
--------------	-----------------------------	-----	----

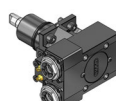

2-Spindel - Winkel-Bohr-Fräseinrichtung, Y-Achse

ER 20	413502012-55 00675000944	1:1	EK
--------------	-----------------------------	-----	----

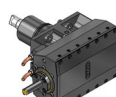

Stoßeinheit für innen und außen

TN765050	414532003-55	1:1	EK
-----------------	--------------	-----	----

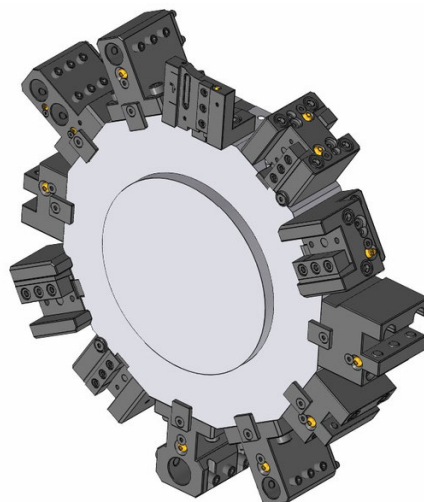
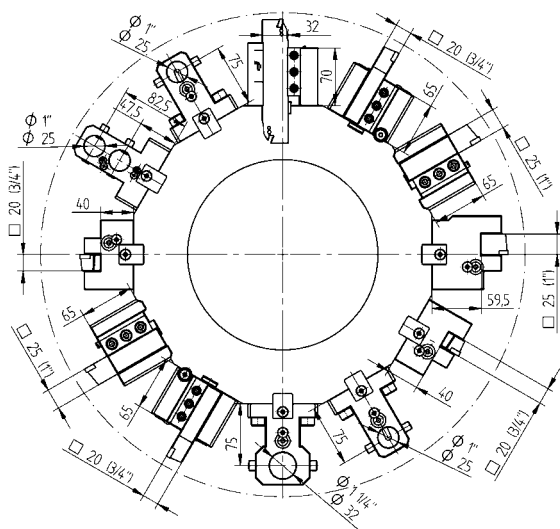

Stehende Werkzeughalter - Standard Programm

Stehende Werkzeughalter - Erweitertes Programm

- 

Plan- und Längsdrehhalter
 20 48-108585
 25 48-106720
- 

Plan- und Längsdrehhalter, HD-IK
 25 48-106720-HP IK 80 bar
- 

Plan- und Längsdrehhalter, beidseitig
 20 48-108460
- 

Plandrehhalter
 20 48-108590
- 

Plandrehhalter
 25 48-107758
- 

Kombihalter
 Ø 25 48-107842 IK 80 bar
 Ø 32 48-106727 IK 80 bar

- 

Abstechhalter
 SH 32 48-99637
- 

Abstechhalter, HD-IK
 SH 32 48-102276R IK 80 bar
 SH 32 48-102276L IK 80 bar
- 

Abstechhalter, einstellbar
 SH 32 48-110366 EK
- 

Abstechhalter, einstellbar, HD-IK
 SH 32 48-109656R IK 80 bar
 343-810100R87
 SH 32 48-109656L IK 80 bar
 343-810100L87
- 

Kombihalter, 2-fach
 Ø 25 48-108596 IK 80 bar

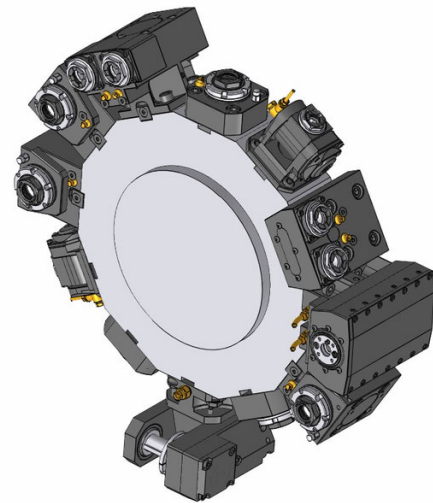
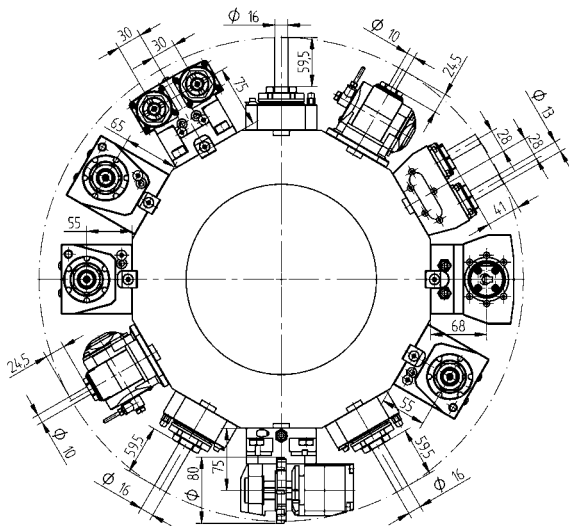

Angetriebene Werkzeughalter - QuickFlex®

Angetriebene Werkzeughalter - Erweitertes Programm



Bohr-Fräseinrichtung - gerade

- ER-25 QF 420125022-55 1:1 EK
 0067725000
- ER-25 QF 420125023-55 1:1 IK 80 bar
 0067725000



Bohr-Fräseinrichtung - gerade

- ER 32 410120002-55 1:1 EK
 0067825000
- ER 32 410120003-55 1:1 IK 80 bar
 0067825000

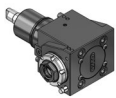

Winkel-Bohr-Fräseinrichtung, LF=55

- ER-25 QF 420525087-55 1:1 EK
 0067725000
- ER-25 QF 420525088-55 1:1 IK 80 bar
 0067725000

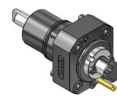

Fräseinrichtung - gerade

- Ø 22 410222002-55 1:1 EK
 00675000483



Winkel-Bohr-Fräseinrichtung, LF=65

- ER-25 QF 420525085-55 1:1 EK
 0067725000
- ER-25 QF 420525086-55 1:1 IK 80 bar
 0067725000



Bohr-Fräseinrichtung - gerade mit Versatz

- ER 25 410116027-55 1:1 EK
 00675000932
- ER 25 410116028-55 1:1 IK 80 bar
 00675000932
- ER 20 410113006-55 1:2 EK
 00675000939
- ER 20 410113004-55 1:2 IK 80 bar
 00675000939
- ER 16 410410000-55 1:3 EK
 00675000937
- ER 16 410410001-55 1:3 IK 80 bar
 00675000937
- ER 25 410116021-55 2:1 EK
 00675000932
- ER 25 410116022-55 2:1 IK 80 bar
 00675000932



Winkel-Bohr-Fräseinrichtung, beidseitig, LF=55

- ER-25 QF 420525069-55 1:1 EK
 0067725000



Winkel-Bohr-Fräseinrichtung, beidseitig, LF=65

- ER-25 QF 420525077-55 1:1 EK
 0067725000

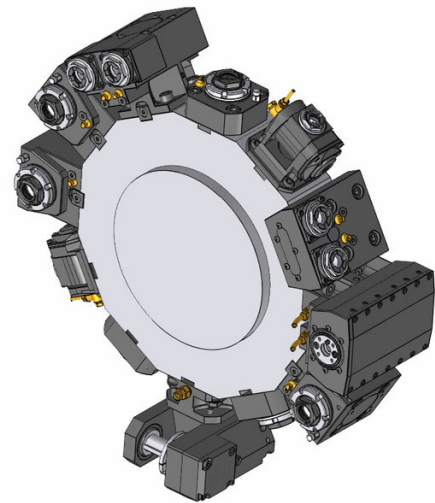
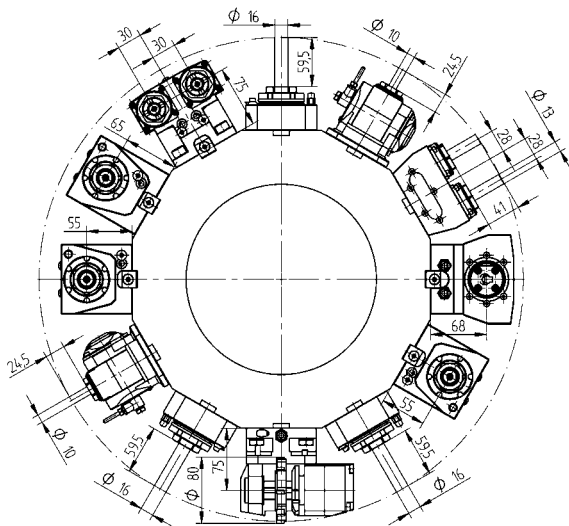

Angetriebene Werkzeughalter - Erweitertes Programm

Angetriebene Werkzeughalter - Erweitertes Programm



Winkel-Bohr-Fräseinrichtung, LF=65

ER 32	410520045-55 0067825000	1:1	EK
ER 32	410520046-55 0067825000	1:1	IK 80 bar
ER-20 QF	420520029-55 0067720001	1:2	EK
ER-20 QF	420520030-55 0067720001	1:2	IK 80 bar
ER 16	410810022-55 00675000841	1:3	EK
ER 16	410810023-55 00675000841	1:3	IK 80 bar
ER-25 QF	420525055-55 0067725000	2:1	EK
ER-25 QF	420525056-55 0067725000	2:1	IK 80 bar

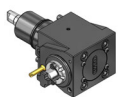

Winkel-Fräseinrichtung für DIN 6358, LF=65

Ø 22	410622013-55 00675000483	1:1	EK
Ø 22	410622007-55 00675000483	2:1	EK



Winkel-Bohr-Fräseinrichtung - zurückgesetzt, LF=65

ER 32	410520007-55 00675000592	1:1	EK
ER 32	410520008-55 00675000592	1:1	IK 80 bar
ER 32	410520009-55 00675000592	2:1	EK
ER 32	410520010-55 00675000592	2:1	IK 80 bar



Bohr-Fräseinrichtung - winkelverstellbar

ER 16	411010001-55 00675000902	1:1	EK
ER 16	411010002-55 00675000902	1:1	IK 80 bar
ER 11	411007003-55 00675000914	1:2	EK
ER 11	411007004-55 00675000914	1:2	IK 80 bar

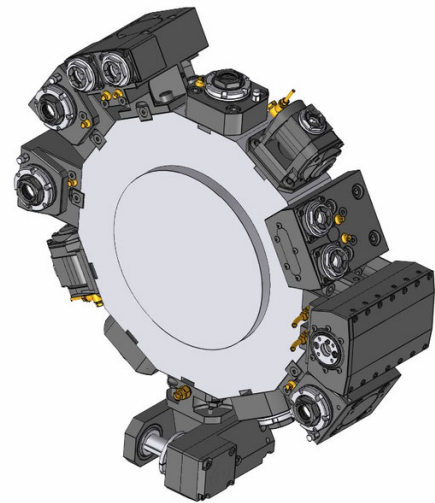
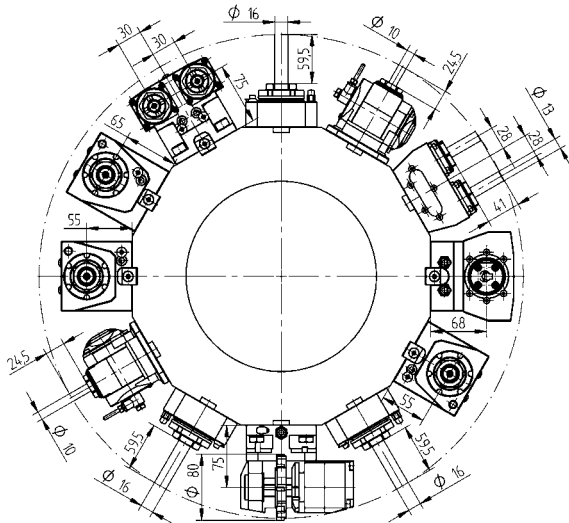



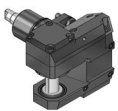





Angetriebene Werkzeughalter - Erweitertes Programm



Fräseinrichtung für Scheibenfräser

Typ 14-2 411500000-55 2,73:1 EK

-  00675000489
-  160016142 Ø 16
-  160022142 Ø 22
-  160027142 Ø 27
-  160015142 Ø 5/8"
-  160019142 Ø 3/4"
-  160023142 Ø 7/8"
-  160025142 Ø 1"



Bohr-Fräseinrichtung, 2-fach, Y-Achse

ER 20 413002001-55 1:1 EK

-  00675000944

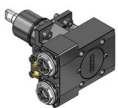

2-Spindel - Winkel-Bohr-Fräseinrichtung, Y-Achse

ER 20 413502012-55 1:1 EK

-  00675000944

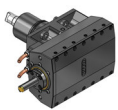

Stoßeinheit für innen und außen

TN765050 414532003-55 1:1 EK

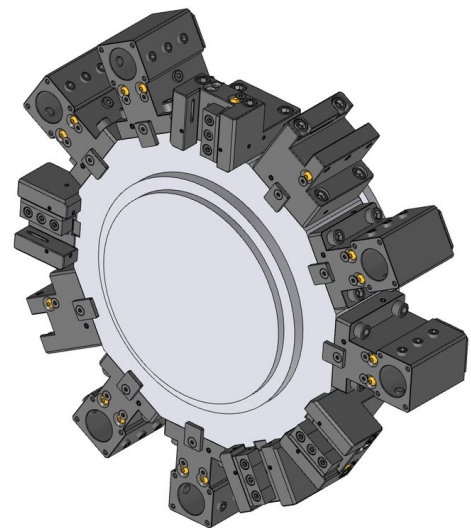
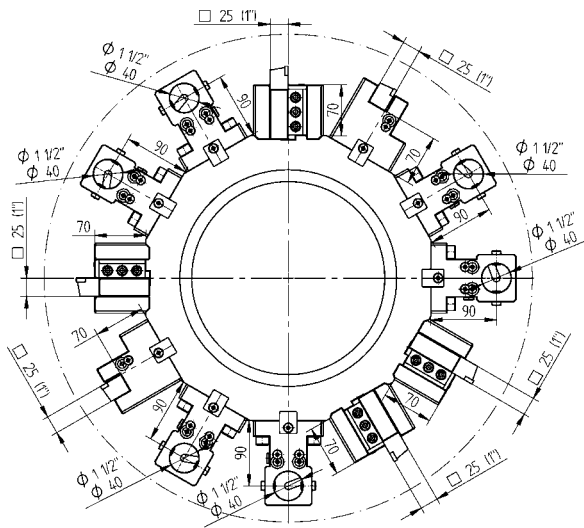

Stehende Werkzeughalter - Standard Programm

Stehende Werkzeughalter - Erweitertes Programm



25 Plan- und Längsdrehhalter, HD-IK
48-107657-HP IK 80 bar



25 Plan- und Längsdrehhalter, beidseitig, HD-IK
48-114828-HP IK 80 bar



25 Plandrehhalter, HD-IK
48-113236-HP IK 80 bar



Ø 40 Kombihalter
48-107659
241140020 ER32
241140026 ER40

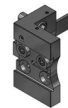

SH 32 Abstechhalter
48-100204



SH 32 Abstechhalter, HD-IK
48-102279R IK 80 bar
48-102279L IK 80 bar

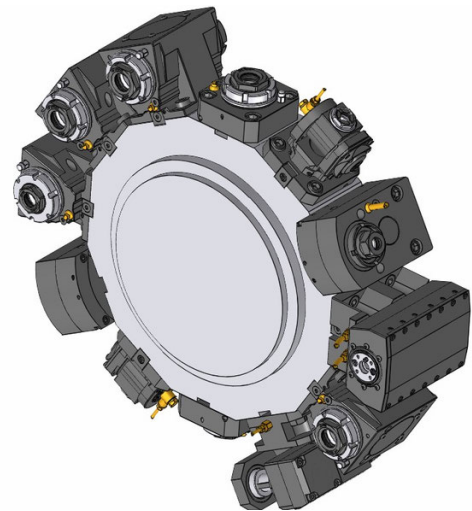
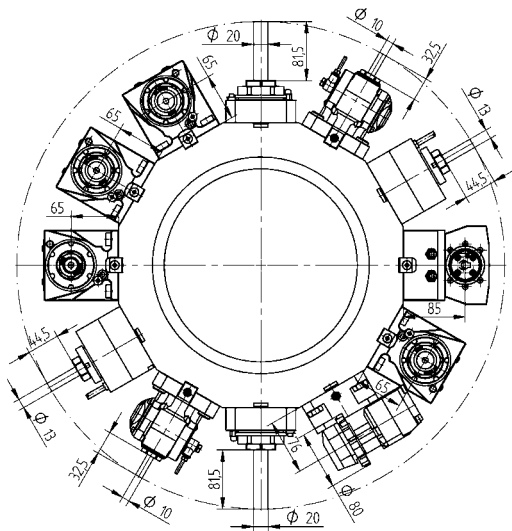

Angetriebene Werkzeughalter - QuickFlex®

Angetriebene Werkzeughalter - Erweitertes Programm



Bohr-Fräseinrichtung - gerade

- ER-32 QF 420132019-65 1:1 EK
0067732000
- ER-32 QF 420132020-65 1:1 IK 80 bar
0067732000

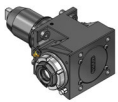

Winkel-Bohr-Fräseinrichtung

- ER-32 QF 420532025-65 1:1 EK
0067732000
- ER-32 QF 420532026-65 1:1 IK 80 bar
0067732000



Winkel-Bohr-Fräseinrichtung, beidseitig

- ER-32 QF 420532043-65 1:1 EK
0067732000



Bohr-Fräseinrichtung - gerade mit Versatz

- ER 32 410120030-65 1:1 EK
00675000958
- ER 32 410120031-65 1:1 IK 80 bar
00675000958
- ER 20 410113002-65 1:2 EK
00675000591
- ER 20 410113003-65 1:2 IK 80 bar
00675000591



Winkel-Bohr-Fräseinrichtung

- ER-25 QF 420525014-65 1:2 EK
0067725001
- ER-25 QF 420525015-65 1:2 IK 80 bar
0067725001
- ER-32 QF 420532031-65 2:1 EK
0067732000
- ER-32 QF 420532032-65 2:1 IK 80 bar
0067732000



Bohr-Fräseinrichtung - winkelverstellbar

- ER 16 411010000-65 1:1 EK
00675000902
- ER 16 411010001-65 1:1 IK 80 bar
00675000902
- ER 11 411007001-65 1:2 EK
00675000914
- ER 11 411007000-65 1:2 IK 80 bar
00675000914

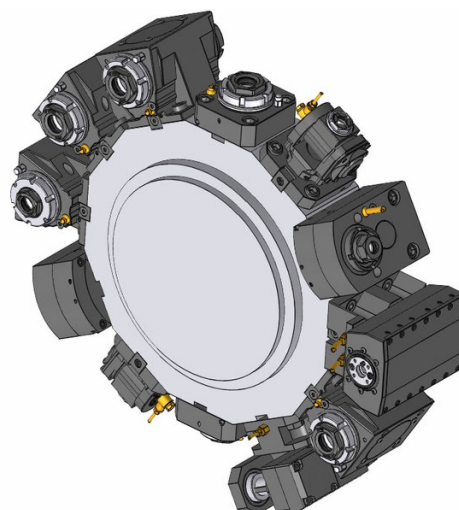
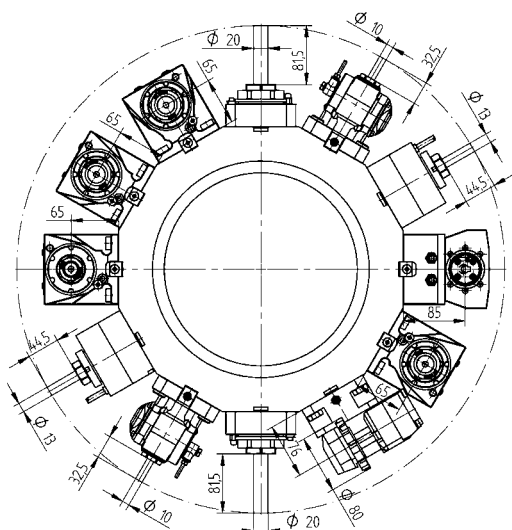

Angetriebene Werkzeughalter - Erweitertes Programm

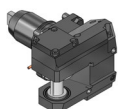

Querfräseinrichtung für Scheibenfräser

Typ 14-2 411500001-65 2,73:1 EK

- 00675000448
- 160016142 Ø 16
- 160022142 Ø 22
- 160027142 Ø 27
- 160015142 Ø 5/8"
- 160019142 Ø 3/4"
- 160023142 Ø 7/8"
- 160025142 Ø 1"

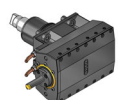

Stoßeinheit für innen und außen

TN765050 414532003-65 1:1 EK

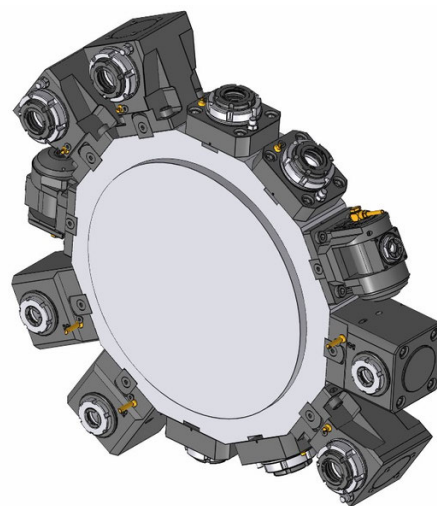
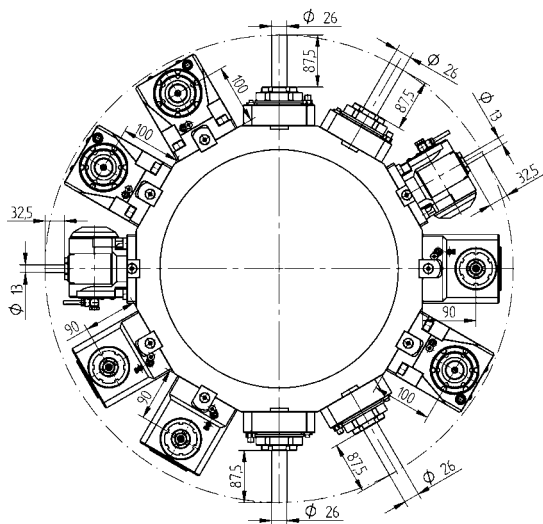

Angetriebene Werkzeughalter - QuickFlex®

Angetriebene Werkzeughalter - Erweitertes Programm



Bohr-Fräseinrichtung - gerade

- ER-40 QF** 420140010-75 1:1 EK
 0067740000
- ER-40 QF** 420140011-75 1:1 IK 80 bar
 0067740000



Winkel-Bohr-Fräseinrichtung

- ER 25** 410516000-75 1:2 EK
 00675000897
- ER 25** 410516001-75 1:2 IK 80 bar
 00675000897



Winkel-Bohr-Fräseinrichtung

- ER-40 QF** 420540010-75 1:1 EK
 0067740000
- ER-40 QF** 420540011-75 1:1 IK 80 bar
 0067740000

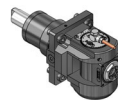

Bohr-Fräseinrichtung - winkelverstellbar

- ER 20** 411013000-75 1:1 EK
 00675000928
- ER 20** 411013001-75 1:1 IK 80 bar
 00675000928
- ER 16** 411010000-75 1:2 EK
 00675000936
- ER 16** 411010001-75 1:2 IK 80 bar
 00675000936

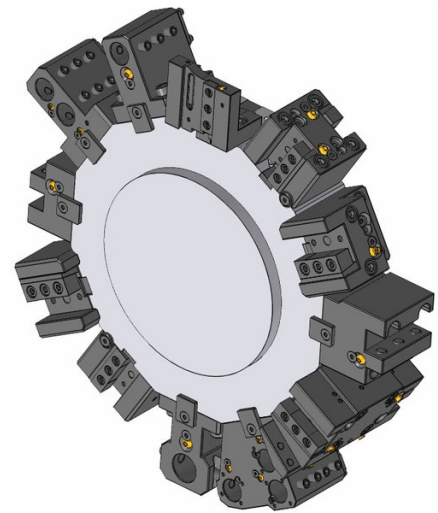
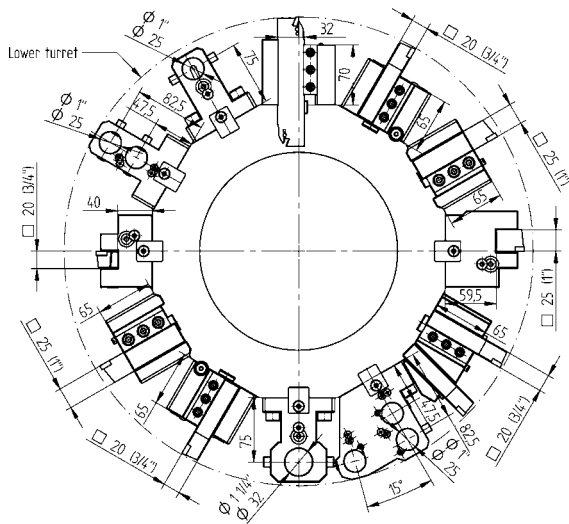

Stehende Werkzeughalter - Standard Programm

Stehende Werkzeughalter - Erweitertes Programm

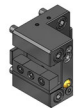

Plan- und Längsdrehhalter

20 48-108585
25 48-106720



Plan- und Längsdrehhalter, HD-IK

25 48-106720-HP IK 80 bar

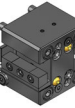

Plan- und Längsdrehhalter, beidseitig

20 48-108460



Plandrehhalter

20 48-108590



Plandrehhalter

25 48-107758



Kombihalter

Ø 25 48-107842 IK 80 bar
Ø 32 48-106727 IK 80 bar



Plan- und Längsdrehhalter, 2-fach, 24 Stationen (nur für Revolver-SW340)

20 48-108592 EK

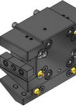

Plan- und Längsdrehhalter, beidseitig, 2-fach, 24 Stationen (nur für Revolver-SW340)

20 48-108461 EK

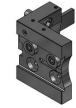

Abstechhalter

SH 32 48-99637



Abstechhalter, HD-IK

SH 32 48-102276R IK 80 bar
SH 32 48-102276L IK 80 bar

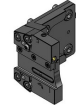

Abstechhalter, einstellbar, HD-IK

SH 32 48-109656R IK 80 bar
343-810100R87
SH 32 48-109656L IK 80 bar
343-810100L87

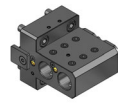

Kombihalter, 2-fach

Ø 25 48-108596 IK 80 bar

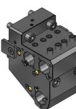

Kombihalter, universal, 3-fach, 24 Stationen (nur für Revolver-SW340)

Ø 25 48-108462 IK 80 bar

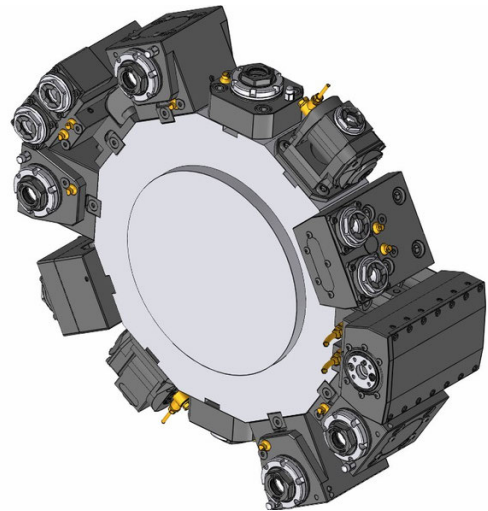
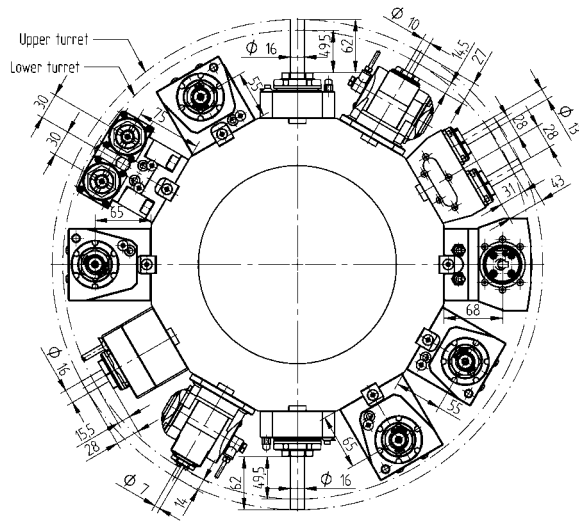

Angetriebene Werkzeughalter - QuickFlex®

Angetriebene Werkzeughalter - Erweitertes Programm



Bohr-Fräseinrichtung - gerade

- ER-25 QF 420125022-55 1:1 EK
0067725000
- ER-25 QF 420125023-55 1:1 IK 80 bar
0067725000



Bohr-Fräseinrichtung - gerade

- ER 32 410120002-55 1:1 EK
0067825000
- ER 32 410120003-55 1:1 IK 80 bar
0067825000

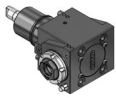

Winkel-Bohr-Fräseinrichtung, LF=55

- ER-25 QF 420525087-55 1:1 EK
0067725000
- ER-25 QF 420525088-55 1:1 IK 80 bar
0067725000

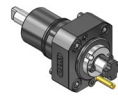

Fräseinrichtung - gerade

- Ø 22 410222002-55 1:1 EK
00675000483



Winkel-Bohr-Fräseinrichtung, LF=65

- ER-25 QF 420525085-55 1:1 EK
0067725000
- ER-25 QF 420525086-55 1:1 IK 80 bar
0067725000



Bohr-Fräseinrichtung - gerade mit Versatz

- ER 25 410116027-55 1:1 EK
00675000932
- ER 25 410116028-55 1:1 IK 80 bar
00675000932
- ER 20 410113006-55 1:2 EK
00675000939
- ER 20 410113004-55 1:2 IK 80 bar
00675000939
- ER 16 410410000-55 1:3 EK
00675000937
- ER 16 410410001-55 1:3 IK 80 bar
00675000937
- ER 25 410116021-55 2:1 EK
00675000932
- ER 25 410116022-55 2:1 IK 80 bar
00675000932



Winkel-Bohr-Fräseinrichtung, beidseitig, LF=55

- ER-25 QF 420525069-55 1:1 EK
0067725000



Winkel-Bohr-Fräseinrichtung, beidseitig, LF=65

- ER-25 QF 420525077-55 1:1 EK
0067725000

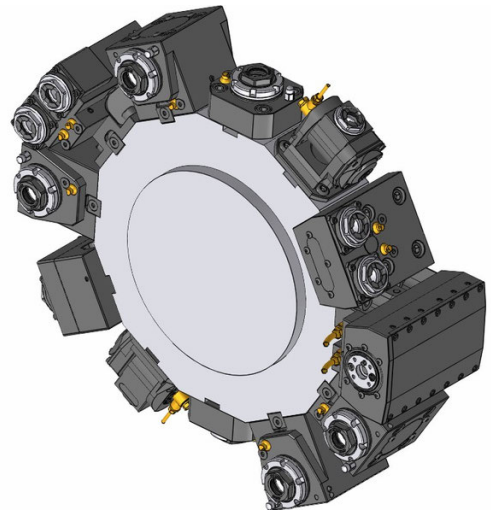
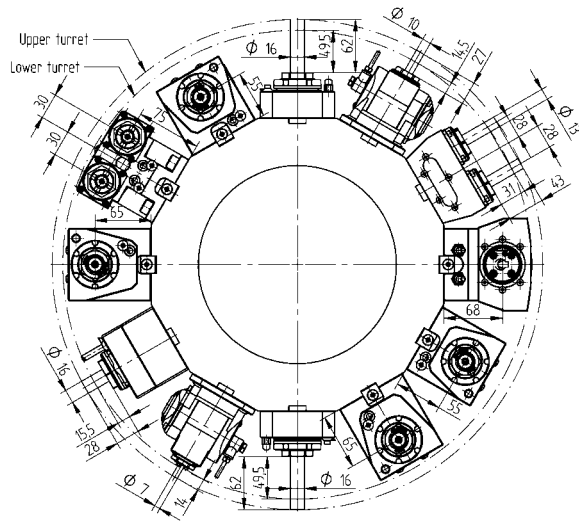

Angetriebene Werkzeughalter - Erweitertes Programm

Angetriebene Werkzeughalter - Erweitertes Programm



Winkel-Bohr-Fräseinrichtung, LF=65

ER 32	410520045-55 0067825000	1:1	EK
ER 32	410520046-55 0067825000	1:1	IK 80 bar
ER-20 QF	420520029-55 0067720001	1:2	EK
ER-20 QF	420520030-55 0067720001	1:2	IK 80 bar
ER 16	410810022-55 00675000841	1:3	EK
ER 16	410810023-55 00675000841	1:3	IK 80 bar
ER-25 QF	420525055-55 0067725000	2:1	EK
ER-25 QF	420525056-55 0067725000	2:1	IK 80 bar

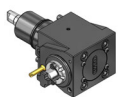

Winkel-Fräseinrichtung für DIN 6358, LF=65

Ø 22	410622013-55 00675000483	1:1	EK
Ø 22	410622007-55 00675000483	2:1	EK

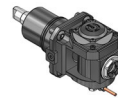

Bohr-Fräseinrichtung - winkelverstellbar

ER 16	411010001-55 00675000902	1:1	EK
ER 16	411010002-55 00675000902	1:1	IK 80 bar
ER 11	411007003-55 00675000914	1:2	EK
ER 11	411007004-55 00675000914	1:2	IK 80 bar



Bohr-Fräseinrichtung, 2-fach, Y-Achse

ER 20	413002001-55 00675000944	1:1	EK
--------------	-----------------------------	-----	----

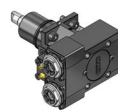

2-Spindel - Winkel-Bohr-Fräseinrichtung, Y-Achse

ER 20	413502012-55 00675000944	1:1	EK
--------------	-----------------------------	-----	----

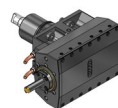

Stoßeinheit für innen und außen

TN765050	414532003-55	1:1	EK
-----------------	--------------	-----	----

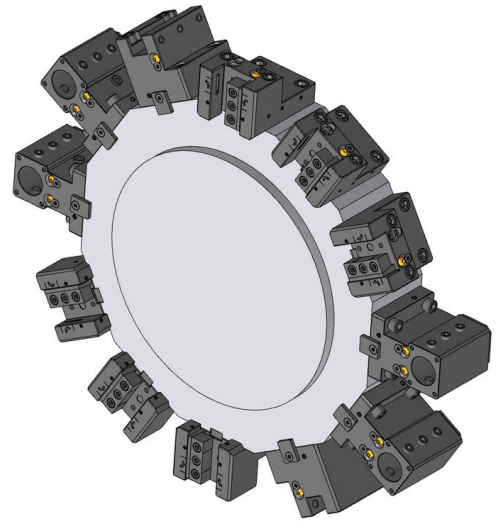
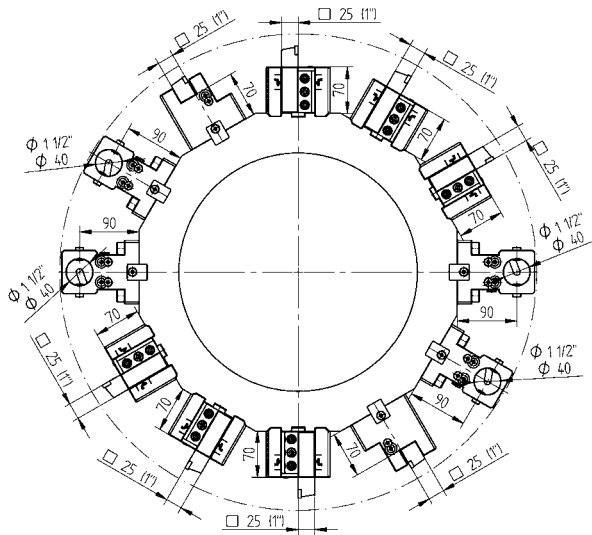

Stehende Werkzeughalter - Standard Programm

Stehende Werkzeughalter - Erweitertes Programm



25 Plan- und Längsdrehhalter, HD-IK
48-107657-HP IK 80 bar



25 Plan- und Längsdrehhalter, beidseitig, HD-IK
48-114828-HP IK 80 bar



25 Plandrehhalter, HD-IK
48-113236-HP IK 80 bar



Ø 40 Kombihalter
48-107659
241140020 ER32
241140026 ER40

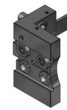

SH 32 Abstechhalter
48-100204



SH 32 Abstechhalter, HD-IK
48-102279R IK 80 bar
SH 32 48-102279L IK 80 bar

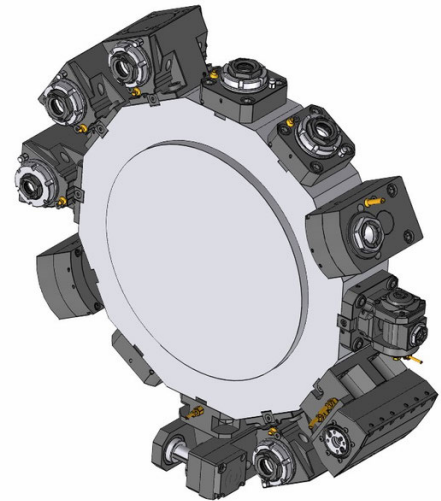
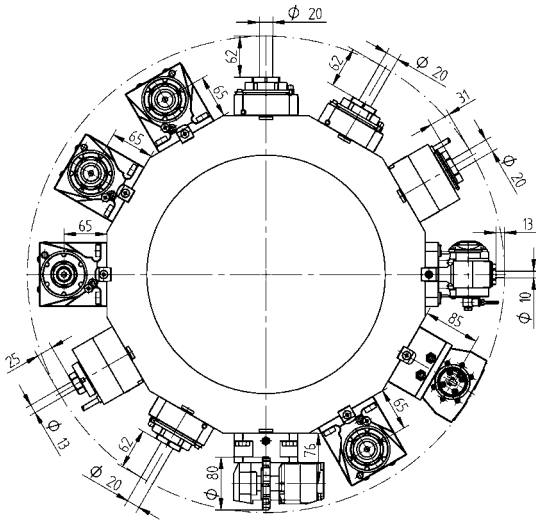

Angetriebene Werkzeughalter - QuickFlex®

Angetriebene Werkzeughalter - Erweitertes Programm



Bohr-Fräseinrichtung - gerade

- ER-32 QF 420132019-65 1:1 EK
0067732000
- ER-32 QF 420132020-65 1:1 IK 80 bar
0067732000



Winkel-Bohr-Fräseinrichtung

- ER-32 QF 420532025-65 1:1 EK
0067732000
- ER-32 QF 420532026-65 1:1 IK 80 bar
0067732000



Winkel-Bohr-Fräseinrichtung, beidseitig

- ER-32 QF 420532043-65 1:1 EK
0067732000



Bohr-Fräseinrichtung - gerade mit Versatz

- ER 32 410120030-65 1:1 EK
00675000958
- ER 32 410120031-65 1:1 IK 80 bar
00675000958
- ER 20 410113002-65 1:2 EK
00675000591
- ER 20 410113003-65 1:2 IK 80 bar
00675000591



Winkel-Bohr-Fräseinrichtung

- ER-25 QF 420525014-65 1:2 EK
0067725001
- ER-25 QF 420525015-65 1:2 IK 80 bar
0067725001
- ER-32 QF 420532031-65 2:1 EK
0067732000
- ER-32 QF 420532032-65 2:1 IK 80 bar
0067732000



Bohr-Fräseinrichtung - winkelverstellbar

- ER 16 411010000-65 1:1 EK
00675000902
- ER 16 411010001-65 1:1 IK 80 bar
00675000902
- ER 11 411007001-65 1:2 EK
00675000914
- ER 11 411007000-65 1:2 IK 80 bar
00675000914

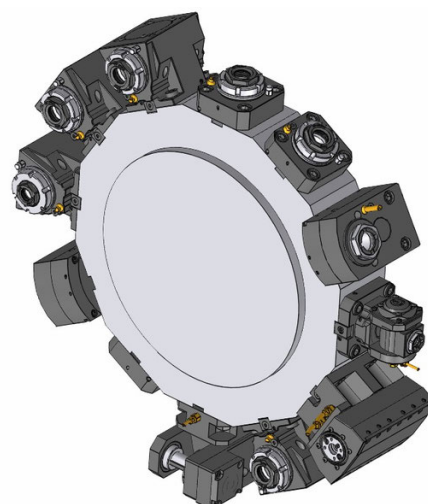
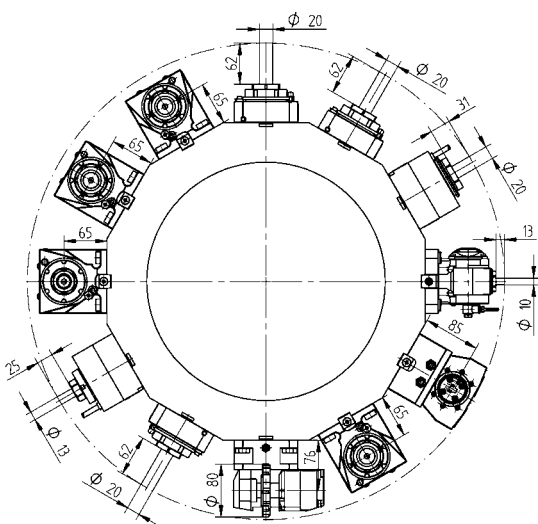



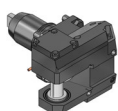





Angetriebene Werkzeughalter - Erweitertes Programm



Querfräseinrichtung für Scheibenfräser

Typ 14-2 411500001-65 2,73:1 EK

-  00675000448
-  160016142 Ø 16
-  160022142 Ø 22
-  160027142 Ø 27
-  160015142 Ø 5/8"
-  160019142 Ø 3/4"
-  160023142 Ø 7/8"
-  160025142 Ø 1"

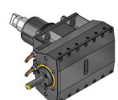

Stoßeinheit für innen und außen

TN765050 414532003-65 1:1 EK

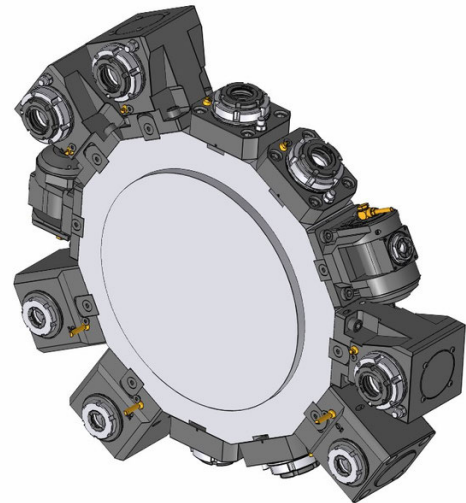
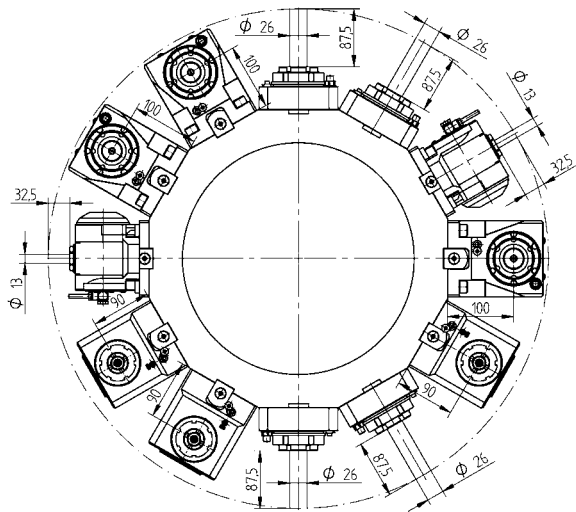

Angetriebene Werkzeughalter - QuickFlex®

Angetriebene Werkzeughalter - Erweitertes Programm



Bohr-Fräseinrichtung - gerade

- ER-40 QF 420140010-75 1:1 EK
 0067740000
- ER-40 QF 420140011-75 1:1 IK 80 bar
 0067740000



Winkel-Bohr-Fräseinrichtung

- ER 25 410516000-75 1:2 EK
 00675000897
- ER 25 410516001-75 1:2 IK 80 bar
 00675000897



Winkel-Bohr-Fräseinrichtung

- ER-40 QF 420540010-75 1:1 EK
 0067740000
- ER-40 QF 420540011-75 1:1 IK 80 bar
 0067740000

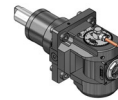

Bohr-Fräseinrichtung - winkelverstellbar

- ER 20 411013000-75 1:1 EK
 00675000928
- ER 20 411013001-75 1:1 IK 80 bar
 00675000928
- ER 16 411010000-75 1:2 EK
 00675000936
- ER 16 411010001-75 1:2 IK 80 bar
 00675000936

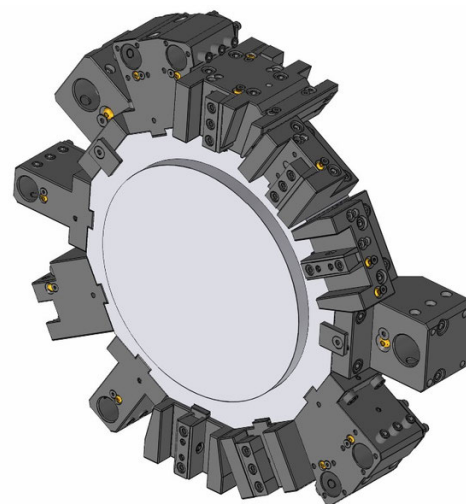
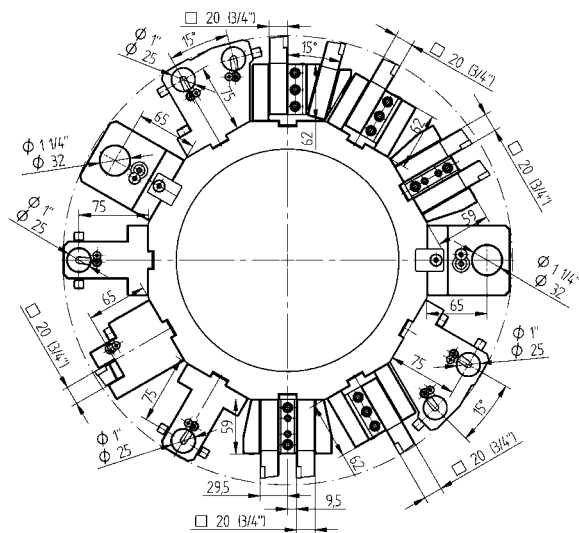

Stehende Werkzeughalter - Standard Programm

Stehende Werkzeughalter - Erweitertes Programm



Plan- und Längsdrehhalter

20 48-101470



Plan- und Längsdrehhalter, HD-IK

20 48-101470-HP IK 80 bar

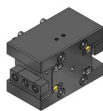

Plan- und Längsdrehhalter, beidseitig

20 48-101471



Plandrehhalter

20 48-102352



Kombihalter, LF=75

Ø 25 48-101472



Kombihalter

Ø 32 48-107155



Plan- und Längsdrehhalter, 2-fach, Y-Achse

20 48-101473

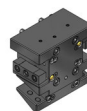

Plan- und Längsdrehhalter, beidseitig, 2-fach, 24 Stationen (nur für Revolver-SW300)

20 48-107973 EK



Abstechhalter

SH 26 48-100419

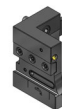

Abstechhalter, HD-IK

SH 26 48-102274R IK 80 bar

SH 26 48-102274L IK 80 bar

SH 32 48-112233R IK 80 bar

343-810100R95

SH 32 48-112233L IK 80 bar

343-810100L95

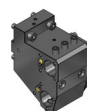

Kombihalter, universal, 2-fach, 24 Stationen (nur für Revolver-SW300)

Ø 25 48-107985 IK 80 bar

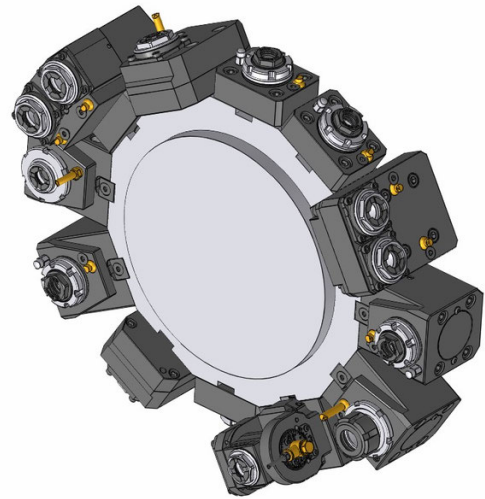
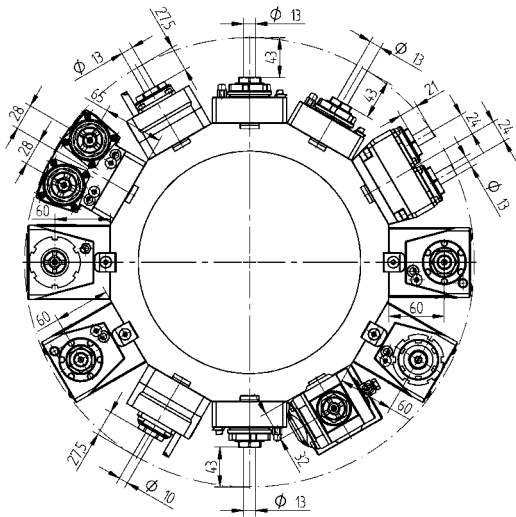

Angetriebene Werkzeughalter - QuickFlex®

Angetriebene Werkzeughalter - Erweitertes Programm



Bohr-Fräseinrichtung - gerade

- ER-20 QF 420120010-44 1:1 EK
 0067720000
- ER-20 QF 420120011-44 1:1 IK 80 bar
 0067720000



Bohr-Fräseinrichtung - gerade

- ER 25 410116004-44 1:1 EK
 00675000720
- ER 25 410116002-44 1:1 IK 80 bar
 00675000720



Winkel-Bohr-Fräseinrichtung, LF=60

- ER-20 QF 420520010-44 1:1 EK
 0067720000
- ER-20 QF 420520011-44 1:1 IK 80 bar
 0067720000

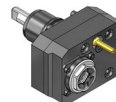

Bohr-Fräseinrichtung - gerade mit Versatz

- ER 20 410113004-44 1:2 EK
 00675000939
- ER 16 410110002-44 1:3 EK
 00675000937
- ER 25 410116005-44 1,5:1 EK
 00675000932



Winkel-Bohr-Fräseinrichtung, beidseitig, LF=60

- ER-20 QF 420520012-44 1:1 EK
 0067720000

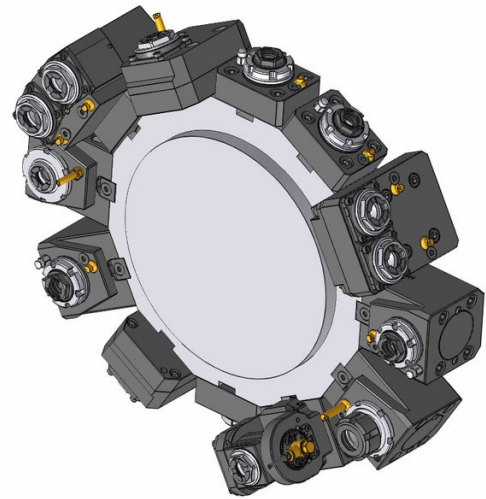
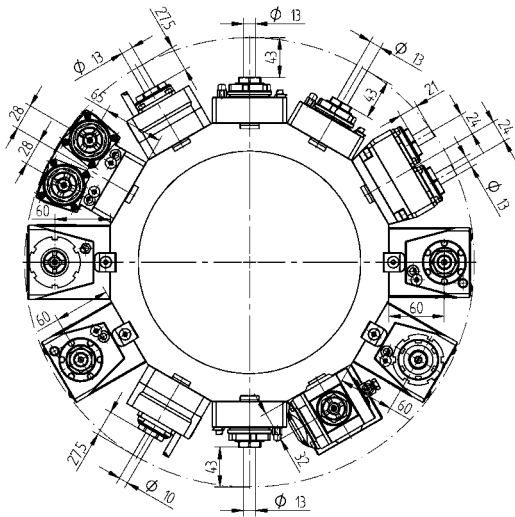

Angetriebene Werkzeughalter - Erweitertes Programm

Angetriebene Werkzeughalter - Erweitertes Programm



Winkel-Bohr-Fräseinrichtung, LF=60

ER 25	410516005-44 00675000720	1:1	EK
ER 25	410516006-44 00675000720	1:1	IK 80 bar
ER 20	410513002-44 00675000833	1:2	EK
ER 20	410513003-44 00675000833	1:2	IK 80 bar
ER 16	410810006-44 00675000841	1:3	EK
ER 16	410810007-44 00675000841	1:3	IK 80 bar
ER 25	410516002-44 00675000720	2:1	EK
ER 25	410516003-44 00675000720	2:1	IK 80 bar

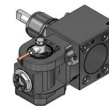

Bohr-Fräseinrichtung - winkelverstellbar, LF=32

ER 16	411010004-44 00675000902	1:1	EK
ER 16	411010005-44 00675000902	1:1	IK 80 bar
ER 11	411007006-44 00675000914	1:2	EK
ER 11	411007007-44 00675000914	1:2	IK 80 bar



Bohr-Fräseinrichtung, 2-fach, Y-Achse

ER 20	413002003-44 00675000939	1:1	EK
ER 20	413002004-44 00675000939	1:1	IK 80 bar

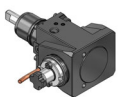

Winkel-Fräseinrichtung für DIN 6358, LF=60

Ø 22	410622000-44 00675000483	1:1	EK
Ø 22	410622001-44 00675000483	2:1	EK

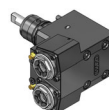

2-Spindel - Winkel-Bohr-Fräseinrichtung, Y-Achse

ER 20	413502004-44 00675000939	1:1	EK
ER 20	413502005-44 00675000939	1:1	IK 80 bar

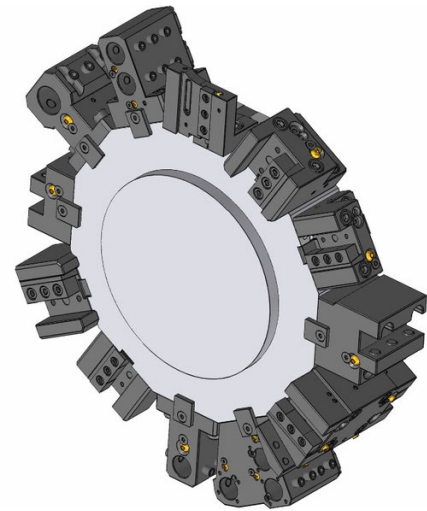
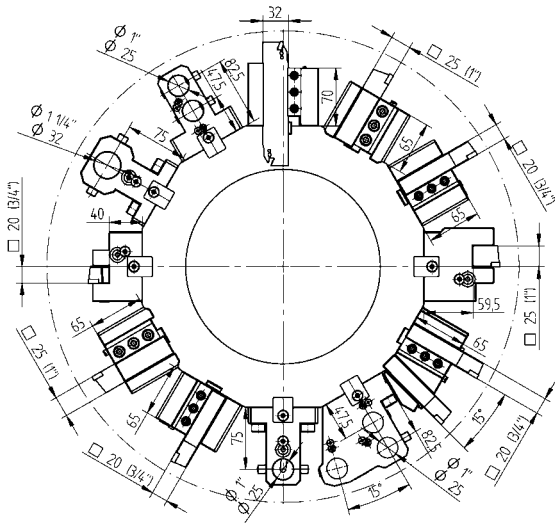

Stehende Werkzeughalter - Standard Programm

Stehende Werkzeughalter - Erweitertes Programm



Plan- und Längsdrehhalter

20 48-108585
25 48-106720



Plan- und Längsdrehhalter, HD-IK

25 48-106720-HP IK 80 bar



Plan- und Längsdrehhalter, beidseitig

20 48-108460



Plandrehhalter

20 48-108590



Plandrehhalter

25 48-107758

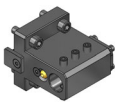

Kombihalter

Ø 25 48-107842 IK 80 bar
Ø 32 48-106727 IK 80 bar



Plan- und Längsdrehhalter, 2-fach, 24 Stationen (nur für Revolver-SW340)

20 48-108592 EK



Plan- und Längsdrehhalter, beidseitig, 2-fach, 24 Stationen (nur für Revolver-SW340)

20 48-108461 EK

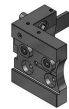

Abstechhalter

SH 32 48-99637



Abstechhalter, HD-IK

SH 32 48-102276R IK 80 bar
SH 32 48-102276L IK 80 bar

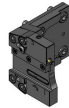

Abstechhalter, einstellbar, HD-IK

SH 32 48-109656R IK 80 bar
343-810100R87
SH 32 48-109656L IK 80 bar
343-810100L87

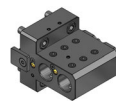

Kombihalter, 2-fach

Ø 25 48-108596 IK 80 bar

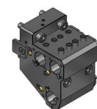

Kombihalter, universal, 3-fach, 24 Stationen (nur für Revolver-SW340)

Ø 25 48-108462 IK 80 bar

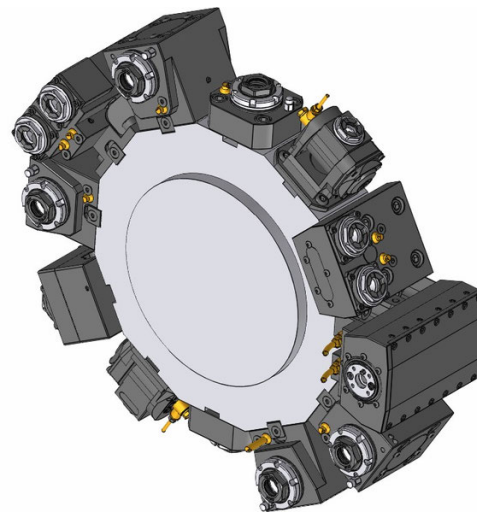
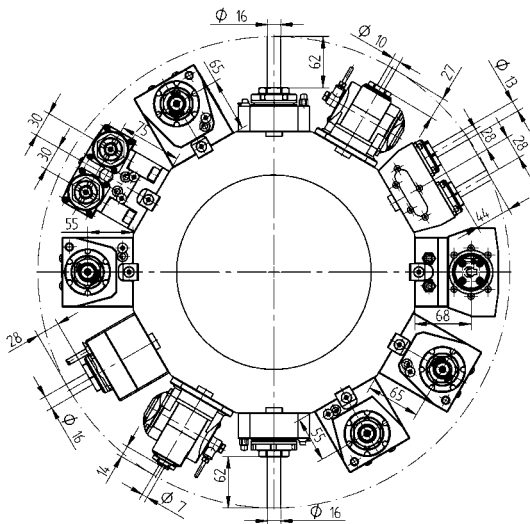

Angetriebene Werkzeughalter - QuickFlex®

Angetriebene Werkzeughalter - Erweitertes Programm



Bohr-Fräseinrichtung - gerade

- ER-25 QF 420125022-55 1:1 EK
0067725000
- ER-25 QF 420125023-55 1:1 IK 80 bar
0067725000



Bohr-Fräseinrichtung - gerade

- ER 32 410120002-55 1:1 EK
0067825000
- ER 32 410120003-55 1:1 IK 80 bar
0067825000

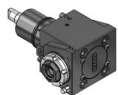

Winkel-Bohr-Fräseinrichtung, LF=55

- ER-25 QF 420525087-55 1:1 EK
0067725000
- ER-25 QF 420525088-55 1:1 IK 80 bar
0067725000

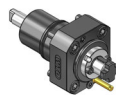

Fräseinrichtung - gerade

- Ø 22 410222002-55 1:1 EK
00675000483

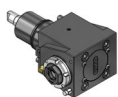

Winkel-Bohr-Fräseinrichtung, LF=65

- ER-25 QF 420525085-55 1:1 EK
0067725000
- ER-25 QF 420525086-55 1:1 IK 80 bar
0067725000



Bohr-Fräseinrichtung - gerade mit Versatz

- ER 25 410116027-55 1:1 EK
00675000932
- ER 25 410116028-55 1:1 IK 80 bar
00675000932
- ER 20 410113006-55 1:2 EK
00675000939
- ER 20 410113004-55 1:2 IK 80 bar
00675000939
- ER 16 410410000-55 1:3 EK
00675000937
- ER 16 410410001-55 1:3 IK 80 bar
00675000937
- ER 25 410116021-55 2:1 EK
00675000932
- ER 25 410116022-55 2:1 IK 80 bar
00675000932



Winkel-Bohr-Fräseinrichtung, beidseitig, LF=55

- ER-25 QF 420525069-55 1:1 EK
0067725000



Winkel-Bohr-Fräseinrichtung, beidseitig, LF=65

- ER-25 QF 420525077-55 1:1 EK
0067725000

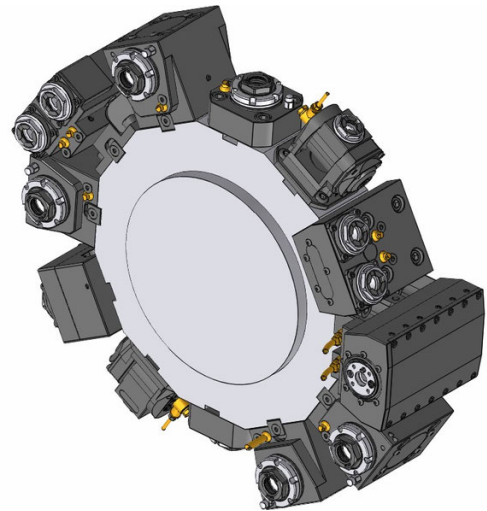
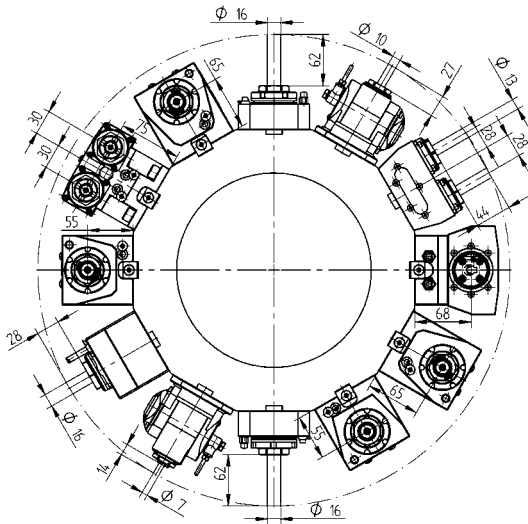

Angetriebene Werkzeughalter - Erweitertes Programm

Angetriebene Werkzeughalter - Erweitertes Programm



Winkel-Bohr-Fräseinrichtung, LF=65

ER 32	410520045-55 0067825000	1:1	EK
ER 32	410520046-55 0067825000	1:1	IK 80 bar
ER-20 QF	420520029-55 0067720001	1:2	EK
ER-20 QF	420520030-55 0067720001	1:2	IK 80 bar
ER 16	410810022-55 00675000841	1:3	EK
ER 16	410810023-55 00675000841	1:3	IK 80 bar
ER-25 QF	420525055-55 0067725000	2:1	EK
ER-25 QF	420525056-55 0067725000	2:1	IK 80 bar

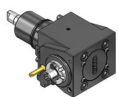

Winkel-Fräseinrichtung für DIN 6358, LF=65

Ø 22	410622013-55 00675000483	1:1	EK
Ø 22	410622007-55 00675000483	2:1	EK



Winkel-Bohr-Fräseinrichtung - zurückgesetzt, LF=65

ER 32	410520007-55 00675000592	1:1	EK
ER 32	410520008-55 00675000592	1:1	IK 80 bar
ER 32	410520009-55 00675000592	2:1	EK
ER 32	410520010-55 00675000592	2:1	IK 80 bar



Bohr-Fräseinrichtung - winkelverstellbar

ER 16	411010001-55 00675000902	1:1	EK
ER 16	411010002-55 00675000902	1:1	IK 80 bar
ER 11	411007003-55 00675000914	1:2	EK
ER 11	411007004-55 00675000914	1:2	IK 80 bar

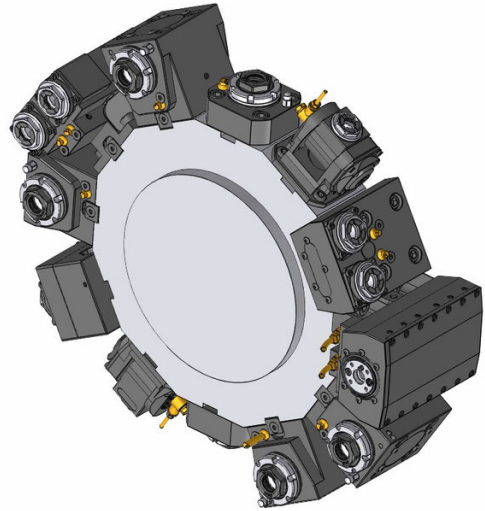
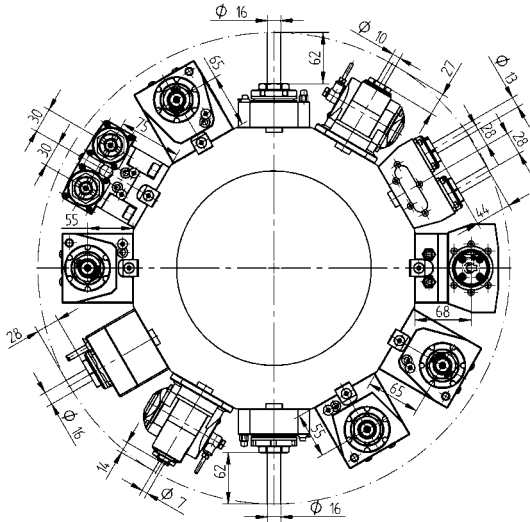

Angetriebene Werkzeughalter - Erweitertes Programm

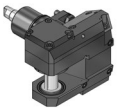

- Typ 14-2** Fräseinrichtung für Scheibenfräser 411500000-55 2,73:1 EK
 00675000489
 160016142 Ø 16
 160022142 Ø 22
 160027142 Ø 27
 160015142 Ø 5/8"
 160019142 Ø 3/4"
 160023142 Ø 7/8"
 160025142 Ø 1"



- ER 20** Bohr-Fräseinrichtung, 2-fach, Y-Achse 413002001-55 1:1 EK
 00675000944

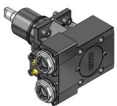

- ER 20** 2-Spindel - Winkel-Bohr-Fräseinrichtung, Y-Achse 413502012-55 1:1 EK
 00675000944

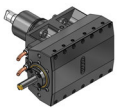

- TN765050** Stoßeinheit für innen und außen 414532003-55 1:1 EK

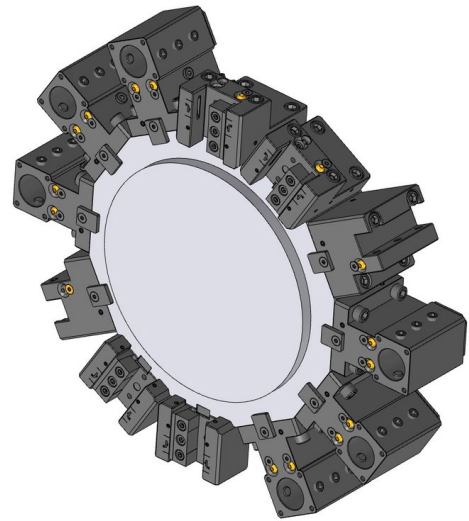
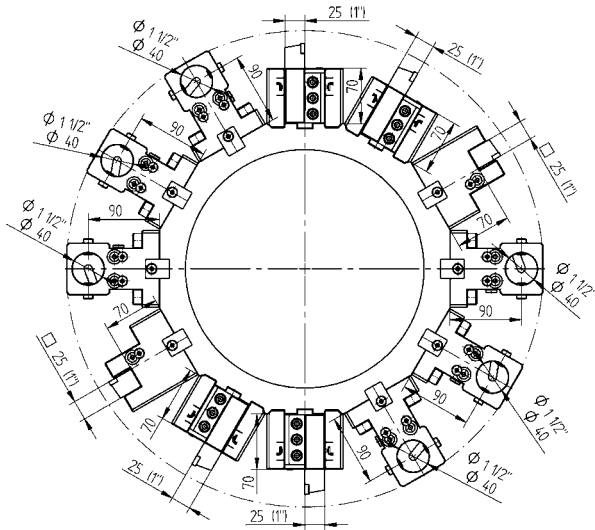

Stehende Werkzeughalter - Standard Programm

Stehende Werkzeughalter - Erweitertes Programm



25 **Plan- und Längsdrehhalter, HD-IK**
48-107657-HP IK 80 bar



25 **Plan- und Längsdrehhalter, beidseitig, HD-IK**
48-114828-HP IK 80 bar



25 **Plandrehhalter, HD-IK**
48-113236-HP IK 80 bar



Ø 40 **Kombihalter**
48-107659
241140020 ER32
241140026 ER40



SH 32 **Abstechhalter**
48-100204



SH 32 **Abstechhalter, HD-IK**
48-102279R IK 80 bar
48-102279L IK 80 bar

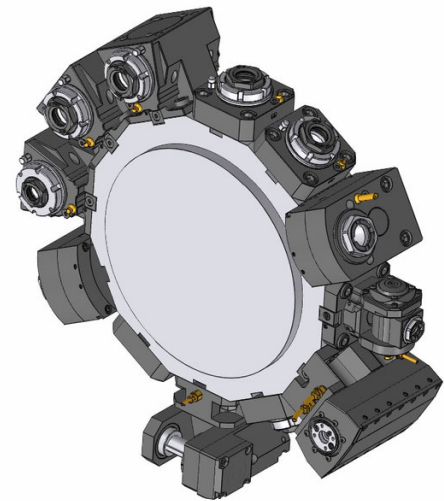
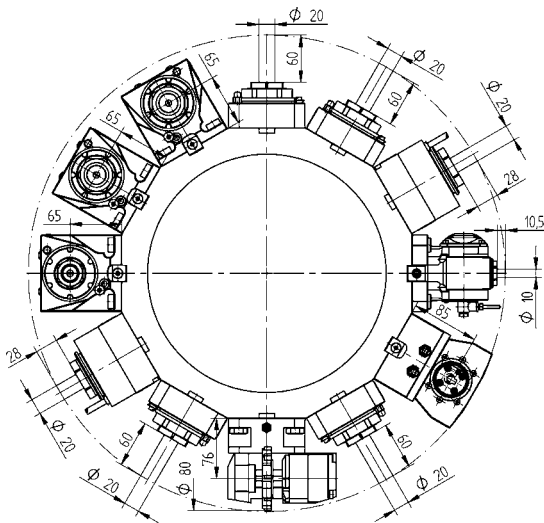

Angetriebene Werkzeughalter - QuickFlex®

Angetriebene Werkzeughalter - Erweitertes Programm



Bohr-Fräseinrichtung - gerade

ER-32 QF 420132019-65 1:1 EK
 0067732000

ER-32 QF 420132020-65 1:1 IK 80 bar
 0067732000

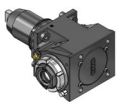

Winkel-Bohr-Fräseinrichtung

ER-32 QF 420532025-65 1:1 EK
 0067732000

ER-32 QF 420532026-65 1:1 IK 80 bar
 0067732000



Winkel-Bohr-Fräseinrichtung, beidseitig

ER-32 QF 420532043-65 1:1 EK
 0067732000



Bohr-Fräseinrichtung - gerade mit Versatz

ER 32 410120030-65 1:1 EK
 00675000958

ER 32 410120031-65 1:1 IK 80 bar
 00675000958

ER 20 410113002-65 1:2 EK
 00675000591

ER 20 410113003-65 1:2 IK 80 bar
 00675000591



Winkel-Bohr-Fräseinrichtung

ER-25 QF 420525014-65 1:2 EK
 0067725001

ER-25 QF 420525015-65 1:2 IK 80 bar
 0067725001

ER-32 QF 420532031-65 2:1 EK
 0067732000

ER-32 QF 420532032-65 2:1 IK 80 bar
 0067732000



Bohr-Fräseinrichtung - winkelverstellbar

ER 16 411010000-65 1:1 EK
 00675000902

ER 16 411010001-65 1:1 IK 80 bar
 00675000902

ER 11 411007001-65 1:2 EK
 00675000914

ER 11 411007000-65 1:2 IK 80 bar
 00675000914

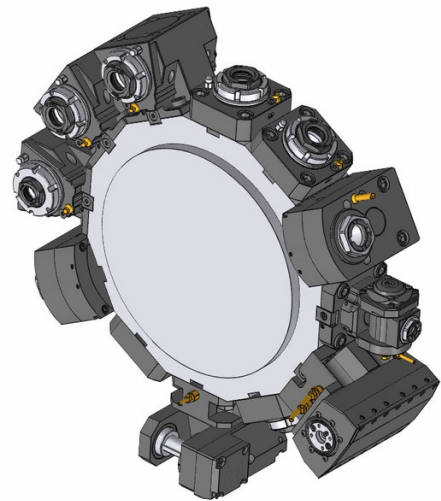
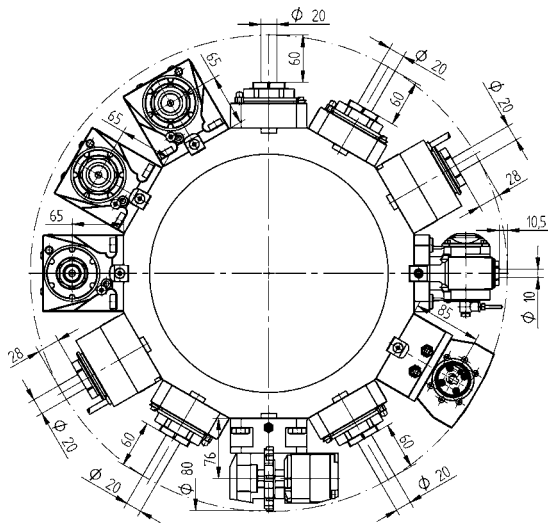

Angetriebene Werkzeughalter - Erweitertes Programm

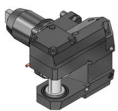

Querfräseinrichtung für Scheibenfräser

Typ 14-2 411500001-65 2,73:1 EK

00675000448

160016142 Ø 16

160022142 Ø 22

160027142 Ø 27

160015142 Ø 5/8"

160019142 Ø 3/4"

160023142 Ø 7/8"

160025142 Ø 1"

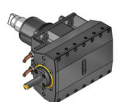

Stoßeinheit für innen und außen

TN765050 414532003-65 1:1 EK

Standard Reduzierhülsen - zylindrisch



Reduzierhülse Ø 25

240025006	ø 6
240025008	ø 8
240025010	ø 10
240025012	ø 12
240025014	ø 14
240025016	ø 16
240025020	ø 20



Reduzierhülse Ø 32

240032006	ø 6
240032008	ø 8
240032010	ø 10
240032012	ø 12
240032014	ø 14
240032016	ø 16
240032018	ø 18
240032020	ø 20
240032025	ø 25



Reduzierhülse Ø 40

240040006	ø 6
240040008	ø 8
240040010	ø 10
240040012	ø 12
240040014	ø 14
240040016	ø 16
240040020	ø 20
240040025	ø 25
240040032	ø 32

Standard Reduzierhülsen - Morsekonus



Reduzierhülse Ø 40

240540001	MK 1
240540002	MK 2
240540003	MK 3
240540004	MK 4

Spannzangen DIN 6499B (ER/ESX)

Spannzangen DIN 6499B (ER/ESX)



ER 11

190011000	ø 7-0.5	ø 0.276-0.020
190011010	ø 1-0.5	ø 0.039-0.020
190011015	ø 1.5-1	ø 0.059-0.039
190011020	ø 2-1.5	ø 0.079-0.059
190011025	ø 2.5-2	ø 0.098-0.079
190011030	ø 3-2.5	ø 0.118-0.098
190011035	ø 3.5-3	ø 0.138-0.118
190011040	ø 4-3.5	ø 0.158-0.138
190011045	ø 4.5-4	ø 0.177-0.158
190011050	ø 5-4.5	ø 0.197-0.177
190011055	ø 5.5-5	ø 0.217-0.197
190011060	ø 6-5.5	ø 0.236-0.217
190011065	ø 6.5-6	ø 0.256-0.236
190011070	ø 7-6.5	ø 0.276-0.256



ER 25

190025000	ø 16-1	ø 0.630-0.039
190025010	ø 1-0.5	ø 0.039-0.020
190025020	ø 2-1	ø 0.079-0.039
190025030	ø 3-2	ø 0.118-0.079
190025040	ø 4-3	ø 0.157-0.118
190025050	ø 5-4	ø 0.197-0.157
190025060	ø 6-5	ø 0.236-0.197
190025070	ø 7-6	ø 0.276-0.236
190025080	ø 8-7	ø 0.315-0.276
190025090	ø 9-8	ø 0.354-0.315
190025100	ø 10-9	ø 0.394-0.354
190025110	ø 11-10	ø 0.433-0.394
190025120	ø 12-11	ø 0.472-0.433
190025130	ø 13-12	ø 0.512-0.472
190025140	ø 14-13	ø 0.551-0.512
190025150	ø 15-14	ø 0.591-0.551
190025160	ø 16-15	ø 0.630-0.591



ER 16

190016000	ø 10-0.5	ø 0.394-0.020
190016010	ø 1-0.5	ø 0.039-0.020
190016020	ø 2-1	ø 0.079-0.039
190016030	ø 3-2	ø 0.118-0.079
190016040	ø 4-3	ø 0.158-0.118
190016050	ø 5-4	ø 0.197-0.158
190016060	ø 6-5	ø 0.236-0.197
190016070	ø 7-6	ø 0.276-0.236
190016080	ø 8-7	ø 0.315-0.276
190016090	ø 9-8	ø 0.354-0.315
190016100	ø 10-9	ø 0.394-0.354



ER 32

190032000	ø 20-2	ø 0.787-0.079
190032020	ø 2-1	ø 0.079-0.039
190032030	ø 3-2	ø 0.118-0.079
190032040	ø 4-3	ø 0.157-0.118
190032050	ø 5-4	ø 0.197-0.157
190032060	ø 6-5	ø 0.236-0.197
190032070	ø 7-6	ø 0.276-0.236
190032080	ø 8-7	ø 0.315-0.276
190032090	ø 9-8	ø 0.354-0.315
190032100	ø 10-9	ø 0.394-0.354
190032110	ø 11-10	ø 0.433-0.394
190032120	ø 12-11	ø 0.472-0.433
190032130	ø 13-12	ø 0.512-0.472
190032140	ø 14-13	ø 0.551-0.512
190032150	ø 15-14	ø 0.591-0.551
190032160	ø 16-15	ø 0.630-0.591
190032170	ø 17-16	ø 0.669-0.630
190032180	ø 18-17	ø 0.709-0.669
190032190	ø 19-18	ø 0.748-0.709
190032200	ø 20-19	ø 0.787-0.748



ER 20

190020000	ø 13-1	ø 0.512-0.039
190020010	ø 1-0.5	ø 0.039-0.020
190020020	ø 2-1	ø 0.079-0.039
190020030	ø 3-2	ø 0.118-0.079
190020040	ø 4-3	ø 0.157-0.118
190020050	ø 5-4	ø 0.197-0.157
190020060	ø 6-5	ø 0.236-0.197
190020070	ø 7-6	ø 0.276-0.236
190020080	ø 8-7	ø 0.315-0.276
190020090	ø 9-8	ø 0.354-0.315
190020100	ø 10-9	ø 0.394-0.354
190020110	ø 11-10	ø 0.433-0.394
190020120	ø 12-11	ø 0.472-0.433
190020130	ø 13-12	ø 0.512-0.472

Spannzangen DIN 6499B (ER/ESX)



ER 40

190040000	ø 26-3	ø 1.024-0.118
190040030	ø 3-2	ø 0.118-0.079
190040040	ø 4-3	ø 0.157-0.118
190040050	ø 5-4	ø 0.197-0.157
190040060	ø 6-5	ø 0.236-0.197
190040070	ø 7-6	ø 0.276-0.236
190040080	ø 8-7	ø 0.315-0.276
190040090	ø 9-8	ø 0.354-0.315
190040100	ø 10-9	ø 0.394-0.354
190040110	ø 11-10	ø 0.433-0.394
190040120	ø 12-11	ø 0.472-0.433
190040130	ø 13-12	ø 0.512-0.472
190040140	ø 14-13	ø 0.551-0.512
190040150	ø 15-14	ø 0.591-0.551
190040160	ø 16-15	ø 0.630-0.591
190040170	ø 17-16	ø 0.669-0.630
190040180	ø 18-17	ø 0.709-0.669
190040190	ø 19-18	ø 0.748-0.709
190040200	ø 20-19	ø 0.787-0.748
190040210	ø 21-20	ø 0.827-0.787
190040220	ø 22-21	ø 0.866-0.827
190040230	ø 23-22	ø 0.906-0.866
190040240	ø 24-23	ø 0.945-0.906
190040250	ø 25-24	ø 0.984-0.945
190040260	ø 26-25	ø 1.024-0.984

Spannzangen DIN 6499D (ER/ESX) - mit Abdichtung für IK



ER 11

191011030	ø 3	
191011040	ø 4	
191011050	ø 5	
191011060	ø 6	
191111013-in		ø 0.125
191111019-in		ø 0.188
191111025-in		ø 0.25



ER 16

191016000	ø 3-10	
191016030	ø 3	
191016040	ø 4	
191016050	ø 5	
191016060	ø 6	
191016070	ø 7	
191016080	ø 8	
191016090	ø 9	
191016100	ø 10	
191116001		ø 0.125-0.375
191116013-in		ø 0.125
191116019-in		ø 0.188
191116025-in		ø 0.25
191116031-in		ø 0.313
191116038-in		ø 0.375



ER 20

191020000	ø 3-12	
191020030	ø 3	
191020040	ø 4	
191020050	ø 5	
191020060	ø 6	
191020070	ø 7	
191020080	ø 8	
191020090	ø 9	
191020100	ø 10	
191020110	ø 11	
191020120	ø 12	
191120001		ø 0.125-0.5
191120013-in		ø 0.125
191120019-in		ø 0.188
191120025-in		ø 0.25
191120031-in		ø 0.313
191120038-in		ø 0.375
191120044-in		ø 0.438
191120050-in		ø 0.5

Spannzangen DIN 6499D (ER/ESX) - mit Abdichtung für IK

Spannzangen DIN 6499D (ER/ESX) - mit Abdichtung für IK



ER 25

191025000	ø 4-16	
191025030	ø 3	
191025040	ø 4	
191025050	ø 5	
191025060	ø 6	
191025070	ø 7	
191025080	ø 8	
191025090	ø 9	
191025100	ø 10	
191025110	ø 11	
191025120	ø 12	
191025130	ø 13	
191025140	ø 14	
191025150	ø 15	
191025160	ø 16	
191125001		ø 0.25-0.625
191125025-in		ø 0.25
191125031-in		ø 0.313
191125038-in		ø 0.375
191125044-in		ø 0.438
191125050-in		ø 0.5
191125056-in		ø 0.563
191125063-in		ø 0.625



ER 40

191040060	ø 6	
191040080	ø 8	
191040100	ø 10	
191040120	ø 12	
191040140	ø 14	
191040160	ø 16	
191040180	ø 18	
191040200	ø 20	
191040220	ø 22	
191040250	ø 25	
191140025-in		ø 0.25
191140031-in		ø 0.313
191140038-in		ø 0.375
191140044-in		ø 0.438
191140050-in		ø 0.5
191140056-in		ø 0.563
191140063-in		ø 0.625
191140069-in		ø 0.688
191140075-in		ø 0.75
191140088-in		ø 0.875
191140100-in		ø 1



ER 32

191032000	ø 4-20	
191032030	ø 3	
191032040	ø 4	
191032050	ø 5	
191032060	ø 6	
191032070	ø 7	
191032080	ø 8	
191032090	ø 9	
191032100	ø 10	
191032110	ø 11	
191032120	ø 12	
191032130	ø 13	
191032140	ø 14	
191032150	ø 15	
191032160	ø 16	
191032170	ø 17	
191032180	ø 18	
191032190	ø 19	
191032200	ø 20	
191132001		ø 0.25-0.75
191132025-in		ø 0.25
191132031-in		ø 0.313
191132038-in		ø 0.375
191132044-in		ø 0.438
191132050-in		ø 0.5
191132056-in		ø 0.563
191132063-in		ø 0.625
191132069-in		ø 0.688
191132075-in		ø 0.75

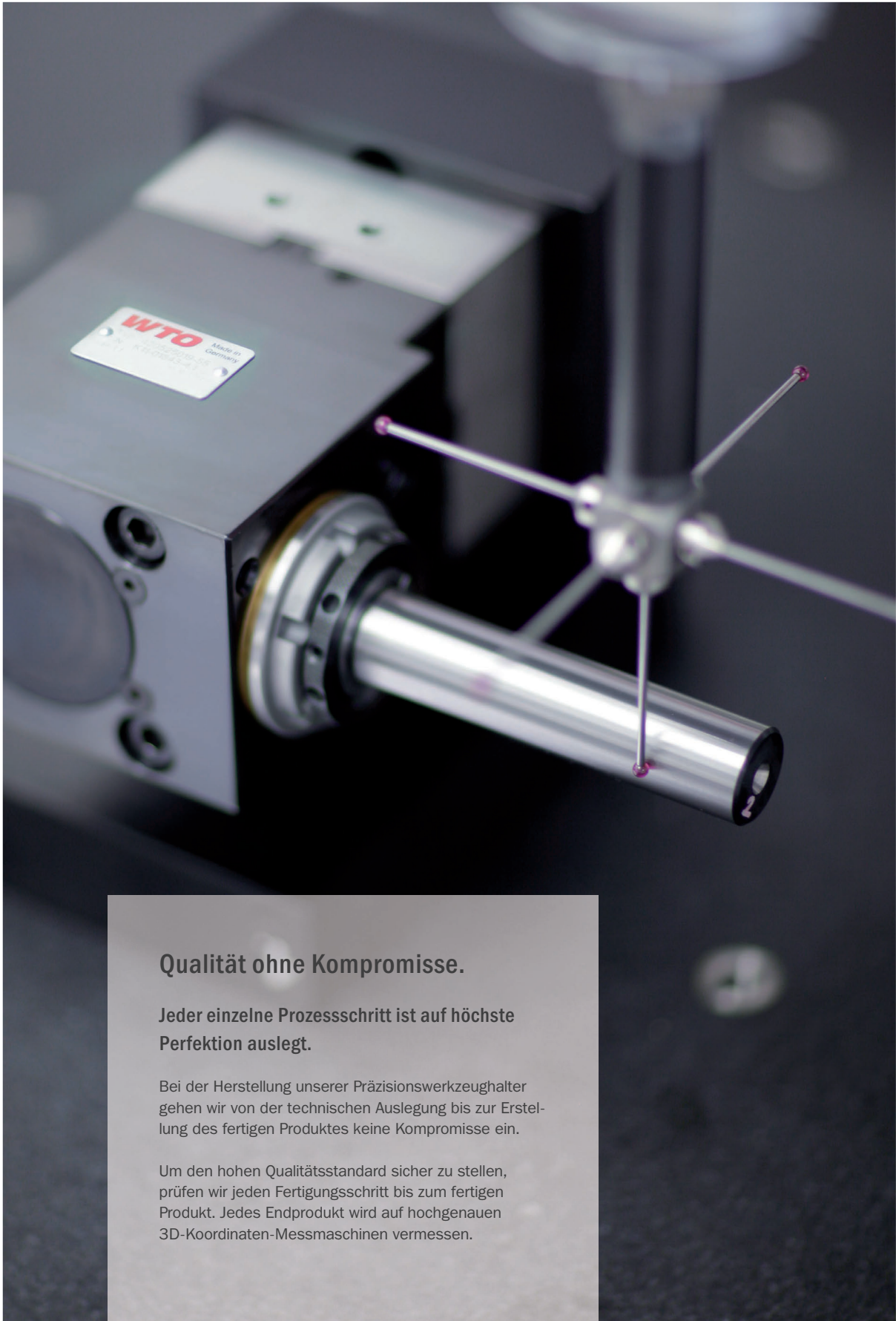

Qualität ohne Kompromisse.

Jeder einzelne Prozessschritt ist auf höchste Perfektion auslegt.

Bei der Herstellung unserer Präzisionswerkzeughalter gehen wir von der technischen Auslegung bis zur Erstellung des fertigen Produktes keine Kompromisse ein.

Um den hohen Qualitätsstandard sicher zu stellen, prüfen wir jeden Fertigungsschritt bis zum fertigen Produkt. Jedes Endprodukt wird auf hochgenauen 3D-Koordinaten-Messmaschinen vermessen.

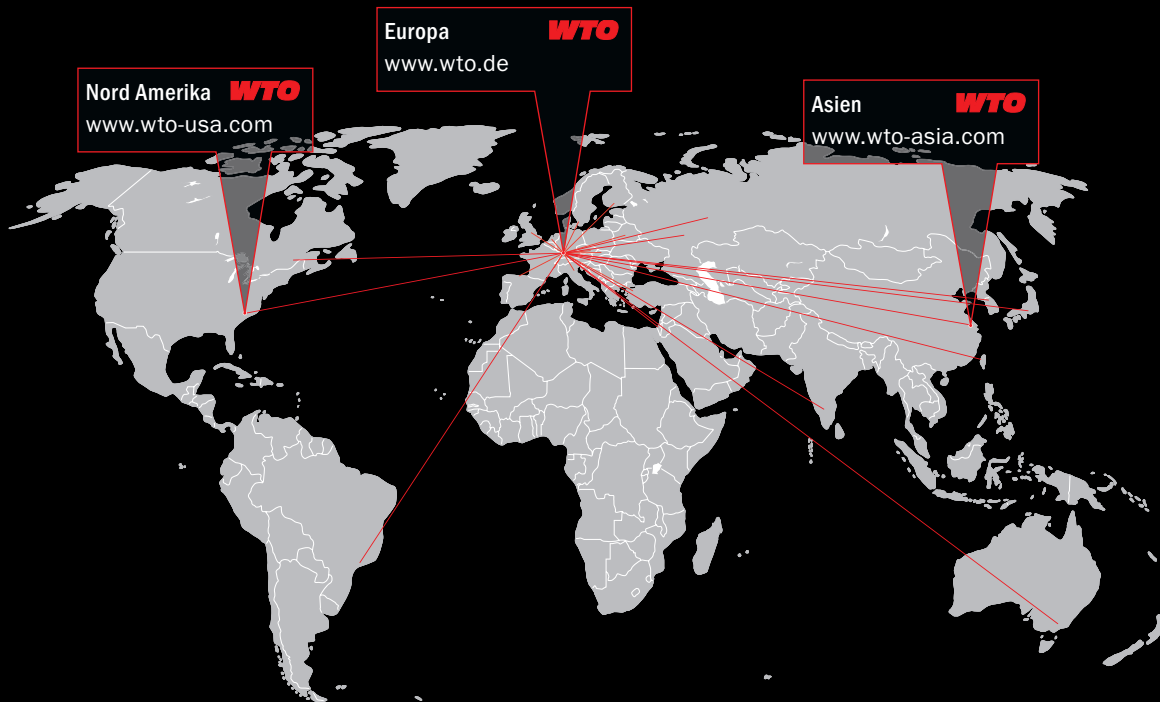

WTO Werkzeug-
Einrichtungen GmbH
Neuer Hohdammweg 1
77797 Ohlsbach
Deutschland

WTO Inc.
13900-F South Lakes Dr.
Charlotte, NC 28273
USA

WTO Asia
WTO Precision Tool Holders
(Shanghai) Co. Ltd.
Room 109-110, Building 2
No. 228 Banting Road
Jiuting Town,
Songjiang District
201615 Shanghai
China

Vertriebspartner – Kompetente Beratung vor Ort

Australien
Dimac Tooling Ltd.
sales@dimac.com.au

Großbritannien
Cutwel Ltd.
sales@cutwel.net

Mexiko
Workholding Engineering De México
info@wem.com.mx

Slowakei
ALBA precision s.r.o.
albabprecision@albabprecision.sk

Belarus
LLC „PMI Engineering“
tool@pmi.by

Indien
Ulhas Patil
u.patil@wto-asia.com

Niederlande
Toologic BeNeLux B.V.
info@toologic-benelux.nl

Spanien
ITALMATIC, S.A.
italmatic@italmatic.es

Brasilien
TF2
tfdois@tfdois.com.br

Israel
E.Y.A.R. Ltd.
boris@eyar.co.il

Norwegen
Helge Karlsen Verktøy og Maskin AS
hkvm@hkvm.no

Taiwan
Kaiko Co., Ltd.
info@kaiko.com.tw

China
Shanghai Gangde
wtocando@yahoo.com

Italien
Prymark srl
commerciale@prymark.it

Polen
ARCO Andrzej Rudenko
info@arcotools.pl

Türkei
MYK CNC MAKINA SAN. VE
huseyin.tatlidil@mykcnc.com.tr

Dänemark
Tool-part
cj@tool-part.dk

Japan
NK Works Co. Ltd.
k_samba@nk-works.co.jp

Rumänien
SC Elif Trading SRL
bulent.ozkan@eliftrading.com

Tschechien
ALBA precision, spol. s.r.o.
info@albabprecision.cz

Finnland
Suomen Terätuonti Oy
myynti@stt.as

Kanada
Mittmann Industrial Inc.
info@mittmann.com

Schweden
Bonhron & Ewing AB
info@bonhron-ewing.se

Ukraine
„LLC“ SPA Stankopromimport
info@phoenix-ua.com

Frankreich
Alexandre Mathelin
alm@wto.de

Korea
WTO Office Korea
is.chon@wto-korea.com

Schweiz
Utilis AG
info@utilis.com