



# NFC TEST REPORT

No.I21Z70218-IOT09

for

**SAMSUNG Electronics Co., Ltd.**

**Multi-band GSM/WCDMA/LTE/5GNR Phone**

**with Bluetooth,WLAN**

**SM-A226BR/DSN,SM-A226BR/N**

**FCC ID : ZCASMA226BRN**

with

**Hardware Version: REV1.0**

**Software Version: A226BR.001**

**Issued Date: 2021-06-29**

**Note:**

The test results in this test report relate only to the devices specified in this report. This report shall not be reproduced except in full without the written approval of CTTL.

The report must not be used by the client to claim product certification, approval, or endorsement by NVLAP, NIST, or any agency of the U.S.Government.

**Test Laboratory:**

**CTTL-Telecommunication Technology Labs, CAICT**

No. 52, Huayuan North Road, Haidian District, Beijing, P. R. China 100191.

Tel:+86(0)10-62304633-2512, Fax:+86(0)10-62304633-2504

Email: [ctl\\_terminals@caict.ac.cn](mailto:ctl_terminals@caict.ac.cn), website: [www.caict.ac.cn](http://www.caict.ac.cn)



## **REPORT HISTORY**

<b>Report Number</b>	<b>Revision</b>	<b>Description</b>	<b>Issue Date</b>
I21Z70218-IOT09	Rev.0	1st edition	2021-06-29

## **CONTENTS**

<b>1. TEST LABORATORY .....</b>	<b>4</b>
<b>1.1. INTRODUCTION &amp; ACCREDITATION.....</b>	<b>4</b>
<b>1.2. TESTING LOCATION .....</b>	<b>4</b>
<b>1.3. TESTING ENVIRONMENT .....</b>	<b>5</b>
<b>1.4. PROJECT DATA .....</b>	<b>5</b>
<b>1.5. SIGNATURE.....</b>	<b>5</b>
<b>2. CLIENT INFORMATION.....</b>	<b>6</b>
<b>2.1. APPLICANT INFORMATION.....</b>	<b>6</b>
<b>2.2. MANUFACTURER INFORMATION.....</b>	<b>6</b>
<b>3. EQUIPMENT UNDER TEST (EUT) AND ANCILLARY EQUIPMENT (AE) .....</b>	<b>7</b>
<b>3.1. ABOUT EUT .....</b>	<b>7</b>
<b>3.2. INTERNAL IDENTIFICATION OF EUT .....</b>	<b>7</b>
<b>3.3. INTERNAL IDENTIFICATION OF AE .....</b>	<b>8</b>
<b>3.4. EUT SET-UPS.....</b>	<b>9</b>
<b>4. REFERENCE DOCUMENTS.....</b>	<b>10</b>
<b>4.1. DOCUMENTS SUPPLIED BY APPLICANT .....</b>	<b>10</b>
<b>4.2. REFERENCE DOCUMENTS FOR TESTING.....</b>	<b>10</b>
<b>5. TEST RESULTS .....</b>	<b>11</b>
<b>5.1. SUMMARY OF TEST RESULTS .....</b>	<b>11</b>
<b>5.2. STATEMENTS.....</b>	<b>12</b>
<b>6. TEST FACILITIES UTILIZED .....</b>	<b>13</b>
<b>7. MEASUREMENT UNCERTAINTY .....</b>	<b>14</b>
<b>ANNEX A: EUT PARAMETERS.....</b>	<b>15</b>
<b>ANNEX B: DETAILED TEST RESULTS.....</b>	<b>16</b>
<b>ANNEX C: PERSONS INVOLVED IN THIS TESTING .....</b>	<b>31</b>
<b>ANNEX D: ACCREDITATION CERTIFICATE .....</b>	<b>32</b>



## **1. Test Laboratory**

### **1.1. Introduction & Accreditation**

**Telecommunication Technology Labs, CAICT** is an ISO/IEC 17025:2017 accredited test laboratory under NATIONAL VOLUNTARY LABORATORY ACCREDITATION PROGRAM (NVLAP) with lab code 600118-0, and is also an FCC accredited test laboratory (CN5017), and ISED accredited test laboratory (ISED#: 24849). The detail accreditation scope can be found on NVLAP website.

### **1.2. Testing Location**

Location 1: CTTL(huayuan North Road)

Address: No. 52, Huayuan North Road, Haidian District, Beijing,  
P. R. China 100191

Location 2: CTTL(CuiHu)

Address: CuiHu Cloud Center No.1 Gaolizhang Road,Wenquan  
Town,Haidian District,Beijing,China

### 1.3. Testing Environment

Normal Temperature: 15-35°C  
Extreme Temperature: -20/+50°C  
Normal Relative Humidity: 20-75%  
Normal Air Pressure: 86Kpa-106Kpa

### 1.4. Project data

Testing Start Date: 2021-03-29  
Testing End Date: 2021-04-28

### 1.5. Signature



---

Zhou Bin  
(Prepared this test report)



---

Zhang Qiang  
(Reviewed this test report)



---

Zhu Liang  
(Approved this test report)



## **2. Client Information**

### **2.1. Applicant Information**

Company Name: SAMSUNG Electronics Co.,Ltd.  
Address: 19 Chapin Rd.,Building D Pine Brook, NJ 07058  
Country: Korea  
Contact: Jenni Chun  
Telephone: +1-201-937-4203  
E-mail: j1.chun@samsung.com

### **2.2. Manufacturer Information**

Company Name: SAMSUNG Electronics Co.,Ltd.  
Address: Samsung R5, Maetan dong 129, Samsung ro Youngtong gu, Suwon city  
443 742, Korea  
Country: Korea  
Contact: Kobe Cho  
Telephone: +82-10-2722-4159  
E-mail: ggobi.cho@samsung.com

### 3. Equipment Under Test (EUT) and Ancillary Equipment (AE)

#### 3.1. About EUT

Description	Multi-band GSM/WCDMA/LTE/5GNR Phone with Bluetooth,WLAN
Model name/HVIN	SM-A226BR/DSN,SM-A226BR/N
Brand name	SAMSUNG
FCC ID	ZCASMA226BRN
UMTS Frequency Band(s)	FDDI/II/IV/V/VIII
GSM Frequency Band(s)	GSM850/900/1800/1900
E-UTRA Frequency Band(s)	FDD1/2/3/4/5/7/8/12/17/20/26/28/28a/28b/66 TDD38/40/41
5G NR Band(s)	n1/n3/n5/n7/n8/n28/n38/n40/n41/n78/n79
EN-DC Band(s)	1A-n1A/n3A/n7A/n28A/n40A/n78A 2A-n28A;3A-n1A/n7A/n28A/n78A;5A-n7A/n78A;7A-n1A/n3A/n5A/n28A/n78A;28A-n1A/n3A/n7A/n78A;40A-n1A/n78A;66A-n5A/n28A;1A-3A-n7A/n28A/n78A;1A-7A-n3A/n28A/n78A;1A-28A-n3A/n7A/n78A;3A-3A-n1A/n7A/n78A;3A-7A-n1A/n28A/n78A;3A-28A-n1A/n7A/n78A;3A-40A-n1A/n78A;7A-28A-n1A/n3A/n78A;66A-66A-n5A;66A_n7A.66A_66A_n7A.
Operating Temperature	-10/+55°C
Nominal Voltage	3.85V
Extreme High Voltage	4.4V
Extreme Low Voltage	3.5V

#### 3.2. Internal Identification of EUT

EUT ID*	IMEI/SNI	HW Version	SW Version	Date of receipt
16a	357297120031332/ 357752230031333	REV1.0	A226B.001	2021-03-29
15a	357297120031530/ 357752230031531	REV1.0	A226B.001	2021-03-29

\*EUT ID: is used to identify the test sample in the lab internally.

### 3.3. Internal Identification of AE

AE ID*	Description	SN
AE1	Charger1	/
AE2	Charger2	/
AE3	Charger3	/
AE4	USB cable1	/
AE5	USB cable2	/
AE6	USB cable3	/
AE7	USB cable4	/
AE8	battery	/
AE1		
Model	EP-TA200	
Manufacturer	RFTECH	
Length of cable	/	
AE2		
Model	EP-TA200	
Manufacturer	Dongwon	
Length of cable	/	
AE3		
Model	EP-TA200	
Manufacturer	SOLUM	
Length of cable	/	
AE4		
Model	EP-DR140AWE	
Manufacturer	RFTECH Co., Ltd.	
Length of cable	/	
AE5		
Model	EP-DR140AWE	
Manufacturer	Ningbo Broad Telecommunication Co., Ltd	
Length of cable	/	
AE6		
Model	EP-DR140AWE	
Manufacturer	DONGGUAN KSD CO.,LTD	
Length of cable	/	
AE7		
Model	EP-DR140AWE	
Manufacturer	CRESYN HANOI Co.,Ltd	
Length of cable	/	
AE8		





Model	SCUD-WT-W1
Manufacturer	SCUD(Fujian)Electronic Co.,Ltd
Capacitance	4900mAh
Nominal voltage	3.85V

\*AE ID: is used to identify the ancillary equipment in the lab internally.

### 3.4. EUT Set-ups

**Table 1: Eut Set-ups**

<b>EUT Set-up No.</b>	<b>Combination of EUT and AE</b>	<b>Remarks</b>
Set.NFC01	15a + AE1 + NFC Card	--
Set.NFC02	15a + NFC Card	--
Set. NFC03	16a	--

The Transmit State of NFC: the NFC function is on. The EUT will transmit the NFC data and command continuously during the test.

The Transmit state without modulation: The EUT will transmit the CW signal at the operating frequency.

## **4. Reference Documents**

### **4.1. Documents supplied by applicant**

EUT parameters, referring to Annex A for detailed information, are supplied by the client or manufacturer, which are the bases of testing.

### **4.2. Reference Documents for testing**

The following documents listed in this section are referred for testing.

<b>Reference</b>	<b>Title</b>	<b>Version</b>
CFR 47 Part 2	Part 2 — Frequency Allocations and Radio Treaty Matters; General Rules and Regulations.	2019
CFR 47 Part 15	Part 15 — Radio Frequency Devices. Subpart C — Intentional Radiators. § 15.35 Measurement detector functions and bandwidths. § 15.207 Conducted limits. § 15.209 Radiated emission limits, general requirements. § 15.215 Additional provisions to the general radiated emission limitations. § 15.225 Operation within the band 13.110–14.010 MHz.	2019
ANSI C63.10	American National Standard of Procedures for Compliance Testing of Unlicensed Wireless Devices	2020

## 5. Test Results

### 5.1. Summary of Test Results

**Table 2: Summary of Test Results**

No	Test Cases	Clause in Regulation	Section in This Report	Verdict
1	Electric Field Strength of Fundamental Emissions	CFR 47 § 15.225(a)	B.1	P(Set. NFC02)
2	Electric Field Strength of Outside the Allocated Bands	CFR 47 § 15.225(b) CFR 47 § 15.225(c)		P(Set. NFC02)
3	Electric Field Radiated Emissions	CFR 47 § 15.209	B.2	P(Set. NFC01)
		CFR 47 § 15.225(d)	B.3	P(Set. NFC01)
4	Frequency Tolerance	CFR 47 § 15.225(e)	B.4	P(Set. NFC03)
5	20dB Bandwidth	CFR 47 § 15.215(c)	B.5	P(Set. NFC03)
6	Conducted Emissions	CFR 47 § 15.207	B.6	P(Set. NFC01)
The measurement is carried out according to ANSI C63.10. See <b>ANNEX B</b> for details.				

#### Test Conditions:

For this report, all the test cases listed above were tested under normal Temperature, Voltage, humidity and Air Pressure except the Frequency Tolerance test case. The specific conditions of Frequency Tolerance test case are listed in section B.4.3

See **Table 3** for terms for result verdict:

**Table 3 Terms for result verdict**

P	Pass, The EUT complies with the essential requirements in the standard.
NP	Not Perform, The test was not performed by CTTL
NA	Not Applicable, The test was not applicable
F	Fail, The EUT does not comply with the essential requirements in the standard



## **5.2. Statements**

This model SM-A226BR/DSN, SM-A226BR/N is a variant product of the model SM-A226B/DSN. All the tests are performed on the SM-A226B/DSN.

The test cases listed in Section 5.1 of this report for the EUT specified in Section 3 were performed by CTTL according to the reference documents in Section 4.

The EUT meets all applicable requirements of the regulations and standards in Section 4.2

## 6. Test Facilities Utilized

Table 4: Test Facilities Utilized

NO.	NAME	TYPE	SERIES NUMBER	PRODUCER	CAL. DUE DATE	CAL. INTERVAL
1.	Spectrum Analyzer	RSA3408A	B010277	Tektronix	2021-10-23	1 Year
2.	Climatic chamber	SH242	93008658	ESPEC	2022-01-22	1 Year
3.	Test Receiver	ESU26	100235	Rohde & Schwarz	2022-02-23	1 Year
4.	BiLog Antenna	VULB9163	9163-483	Schwarzbeck	2021-08-27	1 Year
5.	LISN	ENV216	101200	R&S	2021-05-19	1 Year
6.	Test Receiver	ESCI 3	100344	R&S	2022-02-23	1 Year
7.	H-field Antenna	HFH2-Z2	829324	R&S	2021-12-10	1 Year

## 7. Measurement Uncertainty

Table 5: Measurement Uncertainty

Item	Uncertainty
Frequency Tolerance	$U = 77 \text{ Hz, } k=2$
20dB Bandwidth	$U = 77 \text{ Hz, } k=2$
Radiated Emissions (<1GHz)	$U = 4.86 \text{ dB, } k=2$
Radiated Emissions (>1GHz)	$U = 5.16 \text{ dB, } k=2$
Conducted emission	$U = 3.08 \text{ dB, } k=2$



## **ANNEX A: EUT parameters**

/

## **ANNEX B: Detailed Test Results**

### **B.1. Electric Field Strength of Fundamental and Outside the Allocated bands**

#### **B.1.1. Reference**

See Clause 4, Clause 5 of ANSI C63.10-2013 generally.

#### **B.1.2. Measurement Methods**

The transmitter carrier output levels (E-Field) from the EUT are measured in a semi-anechoic chamber. The EUT is placed on a non-conductive stand of 80cm high, and at a measurement distance of 3m from the receiving antenna. The center of the receiving loop antenna is 1.0 meter above the ground. The E-field is measured with a shielded loop antenna connected to a measurement receiver. Detected E-field was maximized by rotating the EUT through 360° and adjusting the receiving antenna polarizations. The maximization processes were repeated with the EUT positioned respectively in its three orthogonal axes. The measurements were performed with the peak detector and if required, the quasi-peak detector.

The measurement bandwidth is:

**Table B-1: Measurement bandwidth**

Frequency of Emission (MHz)	RBW/VBW
12.56-14.56	10/30 kHz

The E-field measured at 3m is calculated as:

$$\text{E-field (dB}\mu\text{V/m)} = \text{Rx (dB}\mu\text{V)} + \text{Cable Loss (dB)} + \text{AF@3m (dB/m)}$$



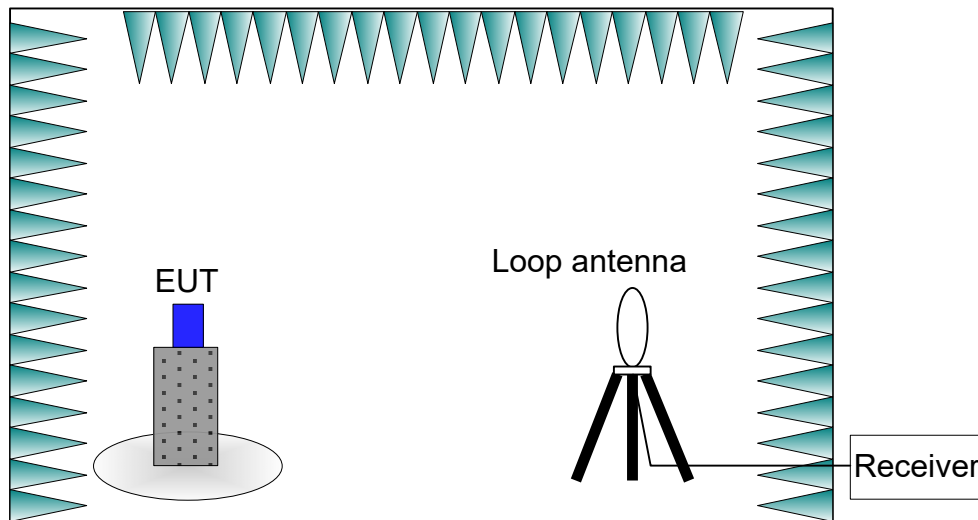

**Figure B-1: Measurement Setup**

### B.1.3. EUT Operating Mode and Test Conditions

The measurement of EUT is carried out under the transmit state of NFC(See 3.4).

The EUT is powered by a travel adapter.

All possible configurations were investigated and only the worst case is reported.

During the measurements, the ambient temperature of the electromagnetic anechoic chamber is in the range of 15 ~ 25 °C.

### B.1.4. Limits

**Table B-2: Limits**

Frequency Range (MHz)	E-field Strength Limit @ 30 m ( $\mu\text{V/m}$ )	E-field Strength Limit @ 3 m ( $\text{dB}\mu\text{V/m}$ )
13.560 $\pm$ 0.007	+15,848	124
13.410 to 13.553 13.567 to 13.710	+334	90
13.110 to 13.410 13.710 to 14.010	+106	81

Note: Where the limits have been defined at one distance, and a signal level measured at another, the limits have been extrapolated using the following formula:

$$\text{Extrapolation(dB)} = 40\log_{10}(\text{Measurement Distance}/\text{Specification Distance})$$

### B.1.5. Measurement Results

Measurement results of normal conditions see Figure B-2 for different set-ups of EUT. The results displayed take into account applicable antenna factors and cable losses.

**Conclusions:** Set.NFC02, **PASS.**

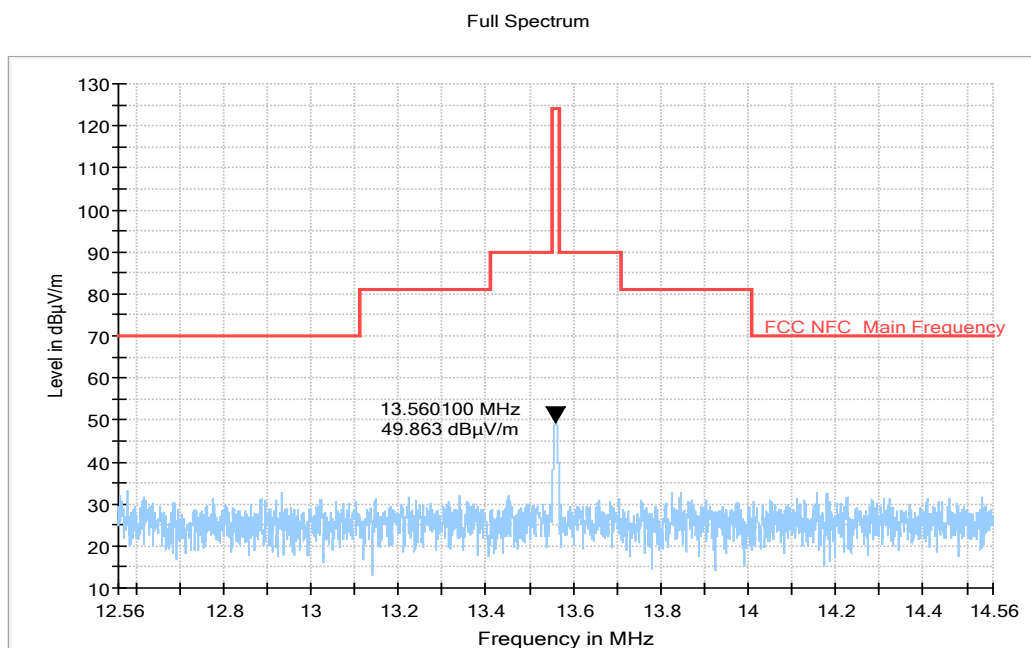

**Figure B-2: Measurement results for Electric Field Strength of Fundamental and Outside the Allocated bands**

## B.2. Electric Field Radiated Emissions (< 30MHz)

### B.2.1. Reference

See Clause 6.4 of ANSI C63.10-2013 specifically.

See Clause 4 and Clause 5 of ANSI C63.10-2013 generally.

### B.2.2. Measurement Methods

The transmitter carrier output levels (E-Field) from the EUT are measured in a semi-anechoic chamber. The EUT is placed on a non-conductive stand of 80cm high, and at a measurement distance of 3m from the receiving antenna. The center of the receiving loop antenna is 1.0 meter

above the ground. The E-field is measured with a shielded loop antenna connected to a measurement receiver. Detected E-field was maximized by rotating the EUT through 360° and adjusting the receiving antenna polarizations. The maximization processes were repeated with the EUT positioned respectively in its three orthogonal axes. The measurements were performed with the peak detector and if required, the quasi-peak detector.

The measurement bandwidth is:

**Table B-3: Measurement bandwidth**

Frequency of Emission (MHz)	RBW/VBW
0.009-0.15	100/300 Hz
0.15-30	10/30 kHz

The E-field measured at 3m is calculated as:

$$\text{E-field (dB}\mu\text{V/m)} = \text{Rx (dB}\mu\text{V)} + \text{Cable Loss (dB)} + \text{AF@3m (dB/m)}$$

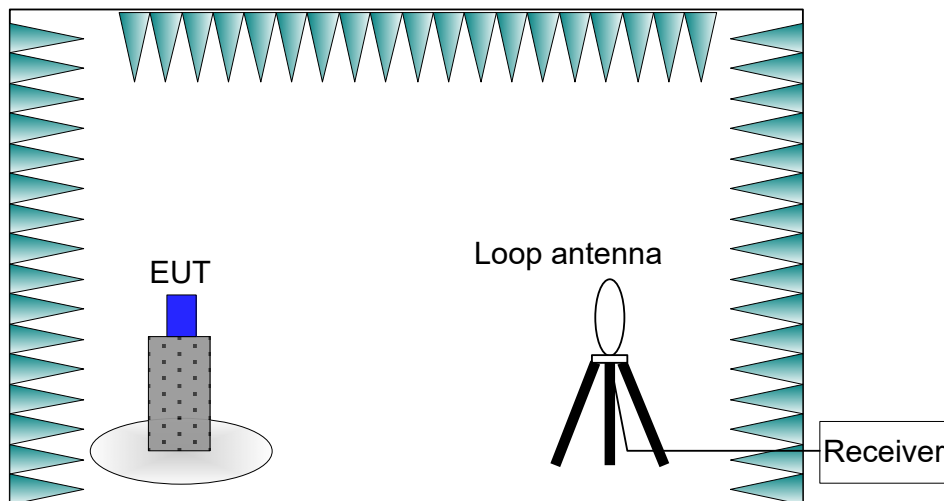

**Figure B-3: Measurement Setup**

### B.2.3. EUT Operating Mode and Test Conditions

The measurement of EUT is carried out under the transmit state of NFC(See 3.4).

The EUT is powered by a travel adapter.

All possible configurations were investigated and only the worst case is reported.

During the measurements, the ambient temperature of the electromagnetic anechoic chamber is

in the range of 15 ~ 25 °C.

### B.2.4. Limits

Table B-4: Limits

Frequency Range (MHz)	E-field Strength Limit @ 30m (mV/m)	E-field Strength Limit @ 3m (dB $\mu$ V/m)
0.009-0.490	2400/F(kHz)	129-94
0.490-1.705	24000/F(kHz)	74-63
1.705-30	30	70

Note: Where the limits have been defined at one distance, and a signal level measured at another, the limits have been extrapolated using the following formula:  
 Extrapolation(dB) =  $40\log_{10}(\text{Measurement Distance}/\text{Specification Distance})$

### B.2.5. Measurement Results

Measurement results of normal conditions see Figure B-4 for different set-ups of EUT. The results displayed take into account applicable antenna factors and cable losses.

**Conclusions:** Set.NFC01, **PASS**.

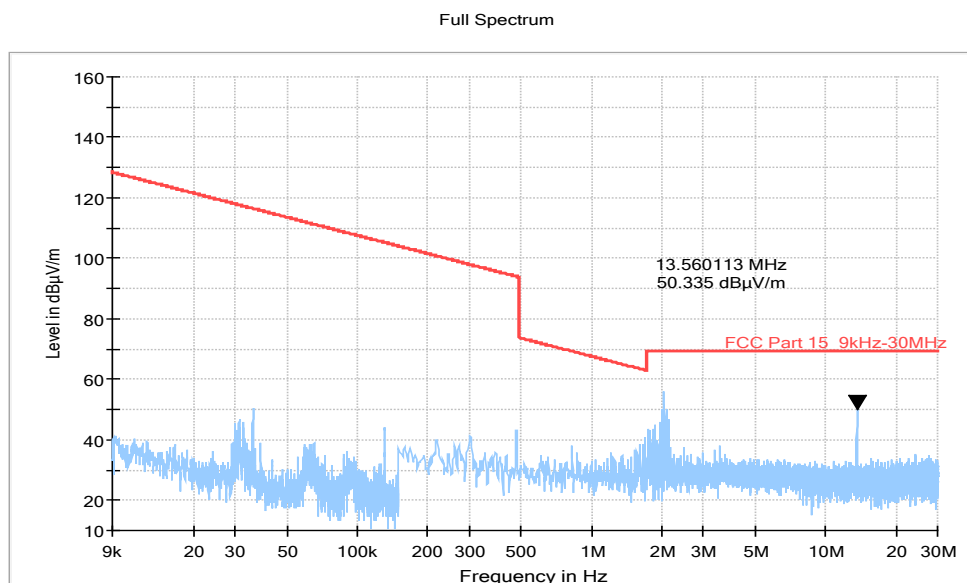

Figure B-4: Measurement results for Electric Field Radiated Emissions (< 30MHz)

### **B.3. Electric Field Radiated Emissions ( $\geq 30\text{MHz}$ )**

#### **B.3.1. Reference**

See Clause 6.5 of ANSI C63.10-2013 specifically.

See Clause 4 and Clause 5 of ANSI C63.10-2013 generally.

#### **B.3.2. Measurement Methods**

The electric field radiated emissions from the EUT are measured in a semi-anechoic chamber. The EUT is placed on a non-conductive stand of 80cm high, and at a measurement distance of 10m from the receiving antenna. The receiving antennas connected to a measurement receiver. In order to search for maximum field strength emitted from the EUT, the receiving antenna can be moved between the height of 1.0 m to 4.0 m. Detected E-field was maximized at each frequency by rotating the EUT through 360° and adjusting the receiving antenna positions for both vertical and horizontal antenna polarizations. The maximization processes were repeated with the EUT positioned respectively in its three orthogonal axes. The measurements were performed with the peak detector and if required, the quasi-peak detector.

The measurement bandwidth is:

**Table B-5: Measurement bandwidth**

Frequency of Emission (MHz)	RBW/VBW
30-1000	120kHz

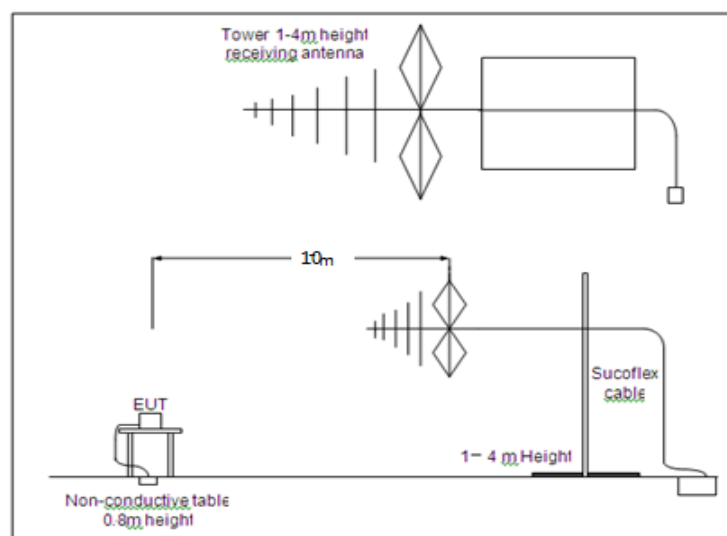

**Figure B-5: Measurement Setup**

### B.3.3. EUT Operating Mode and Test Conditions

The measurement of EUT is carried out under the transmit state of NFC(See 3.4).

The EUT had been connected to a travel adapter.

All possible configurations were investigated and only the worst case is reported.

During the measurements, the ambient temperature of the electromagnetic anechoic chamber is in the range of 15 ~ 25 °C.

### B.3.4. Limits

Table B-6: Limits

Frequency Range (MHz)	E-field Strength Limit @ 3m (mV/m)	E-field Strength Limit @ 3m (dB $\mu$ V/m)	E-field Strength Limit @ 10m (dB $\mu$ V/m)
30-88	100	40	30
88-216	150	43.5	33.5
216-960	200	46	36
960-1000	500	54	44

### B.3.5. Measurement Results

Measurement results of normal conditions see Figure B-6 for different set-ups of EUT. The results displayed take into account applicable antenna factors and cable losses.

**Conclusions:** Set.NFC01, **PASS**.

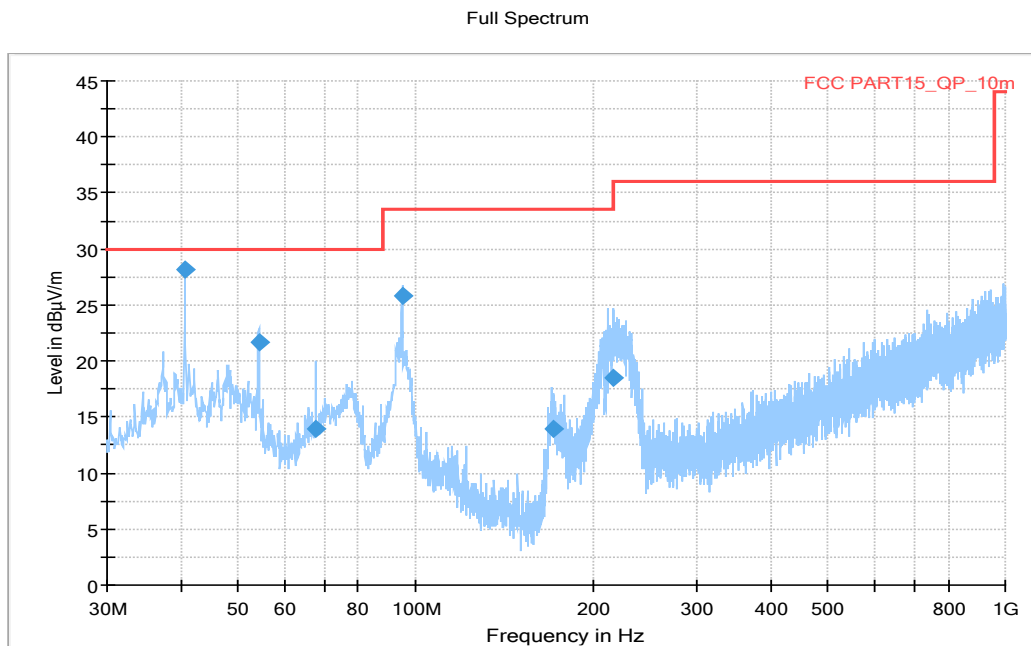

**Figure B-6: Measurement results for Electric Field Radiated Emissions ( $\geq 30\text{MHz}$ )**

**Final\_Result**

Frequency (MHz)	QuasiPeak (dBµV/m)	Height (cm)	Polarization	Azimuth (deg)	Margin (dB)	Limit (dBµV/m)
40.670000	28.13	102.0	V	-2.0	1.87	30.00
54.250000	21.65	101.0	V	-21.0	8.35	30.00
67.733000	13.91	177.0	V	248.0	16.09	30.00
94.893000	25.77	178.0	V	276.0	7.75	33.50
171.135000	13.91	120.0	V	-12.0	19.61	33.50
215.852000	18.51	116.0	V	-11.0	15.01	33.50

**B.4. Frequency Tolerance**

**B.4.1. Reference**

See Clause 6.8 of ANSI C63.10-2013 specifically.

See Clause 4 and Clause 5 of ANSI C63.10-2013 generally.

#### B.4.2. Measurement Methods

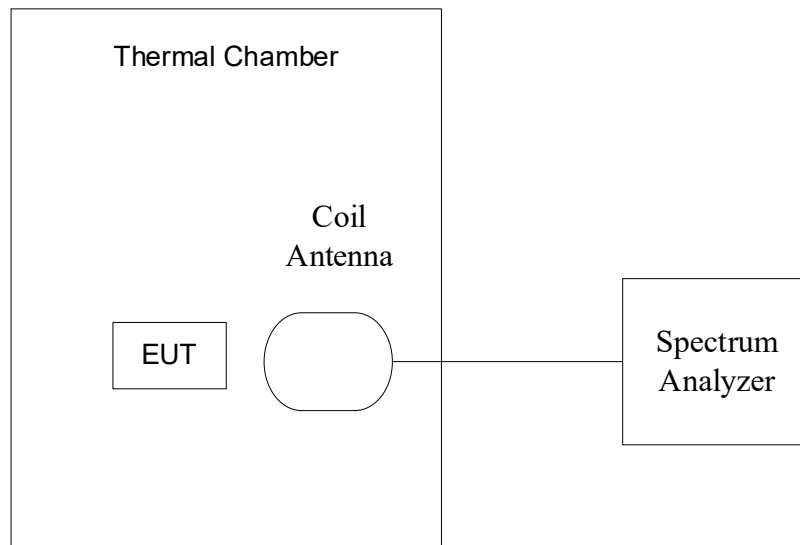

**Figure B-7: Measurement Setup**

The transmitter output signal was picked up by coil antenna connected to the spectrum analyzer. The center frequency was measured with 30Hz RBW and 1kHz span.

During the test, the EUT was placed in a thermal chamber until thermal balance and lasting appropriate time.

#### B.4.3. EUT Operating Mode and Test Conditions

The measurement of EUT was carried out under the transmit state of without modulation(See 3.4).

EUT had not been connected to a travel adapter. The frequency stability was measured with the different voltage and temperature combinations:

- a) The nominal voltage 3.85V(See 3.1)was used and the temperature was varied from -20°C to +50°C in 10°C increments using an environmental chamber.
- b) The 20°C was used and the voltages were 3.5V, 3.85V and 4.4V (The extreme low voltage ,the nominal voltage and the extreme high voltage defined in section 3.1).

The details were as following:

**Table B-7: Combinations of Voltage andTemperature**



Test items	Voltage	Temperature
Frequency stability with respect to ambient temperature	3.85V	-20°C
		-10°C
		0°C
		10°C
		20°C
		30°C
		40°C
		50°C
Frequency stability when varying supply voltage	3.5V	20°C
	3.85V	
	4.4V	

#### B.4.4. Test Layouts

See B.4.2.

#### B.4.5. Limits

The frequency tolerance of the carrier signal shall be maintained within +/- 0.01% of the operating frequency.

#### B.4.6. Measurement Results

Measurement results see Table B-8 for different test conditions.

**Conclusions:** Set.NFC03, **PASS.**

**Table B-8: Measurement results for Frequency Tolerance**

Temperature	Voltage	Frequency (MHz)			
		Startup	2 Min Later	5 Min Later	10 Min Later
-20°C	3.85V	13.560031875	13.560031250	13.560023750	13.560021250

-10°C	3.85V	13.560043125	13.560054375	13.560053125	13.560053750
0°C	3.85V	13.560063125	13.560062675	13.560062250	13.560061875
10°C	3.85V	13.560054375	13.560051875	13.560051250	13.560050625
20°C	3.85V	13.560049375	13.560029375	13.560025625	13.560023750
30°C	3.85V	13.560014375	13.560003125	13.559960625	13.559985625
40°C	3.85V	13.559984375	13.559970125	13.559956875	13.559955625
50°C	3.85V	13.559943125	13.559933125	13.559929375	13.559926875
20°C	3.5V	13.560023125	13.560021875	13.560020625	13.560018125
20°C	4.4 V	13.560000625	13.560006875	13.560018750	13.560019375
Temperature	Voltage	Frequency Error (%)			
		Startup	2 Min Later	5 Min Later	10 Min Later
-20°C	3.85V	0.000	0.000	0.000	0.000
-10°C	3.85V	0.000	0.000	0.000	0.000
0°C	3.85V	0.000	0.000	0.000	0.000
10°C	3.85V	0.000	0.000	0.000	0.000
20°C	3.85V	0.000	0.000	0.000	0.000
30°C	3.85V	0.000	0.000	0.000	0.000
40°C	3.85V	0.000	0.000	0.000	0.000
50°C	3.85V	0.000	0.000	-0.001	-0.001
20°C	3.5V	0.000	0.000	0.000	0.000
20°C	4.4V	0.000	0.000	0.000	0.000

#### B.4.7. Measurement Uncertainty

Measurement uncertainty:  $U = 77 \text{ Hz}$ ,  $k=2$

#### B.5. 20dB Bandwidth

### B.5.1. Reference

See Clause 6.9 of ANSI C63.10-2013 specifically.

See Clause 4 and Clause 5 of ANSI C63.10-2013 generally.

### B.5.2. Measurement Methods

The transmitter output signal was picked up by coil antenna connected to the spectrum analyzer. The bandwidth of the center frequency was measured with 140Hz RBW, 420Hz VBW and 14kHz span.

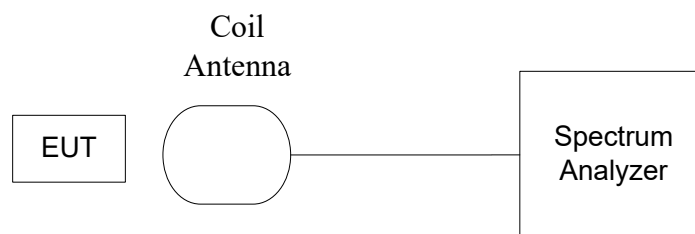

**Figure B-8: Measurement Setup**

### B.5.3. EUT Operating Mode and Test Conditions

The measurement of EUT was carried out under the transmit state of NFC (See 3.4).

EUT had not been connected to a travel adapter.

During the measurements, the ambient temperature was in the range of 15 ~ 25 °C.

### B.5.4. Test Layouts

See B.5.2.

### B.5.5. Limits

The 20dB bandwidth shall be less than 80% of the permitted frequency band. For 13.56 MHz NFC, the permitted frequency band is 14kHz, so the limit is 11.2 kHz.

### B.5.6. Measurement Results

Measurement results see Figure B-9.

**Conclusions:** Set.NFC03, **PASS**.

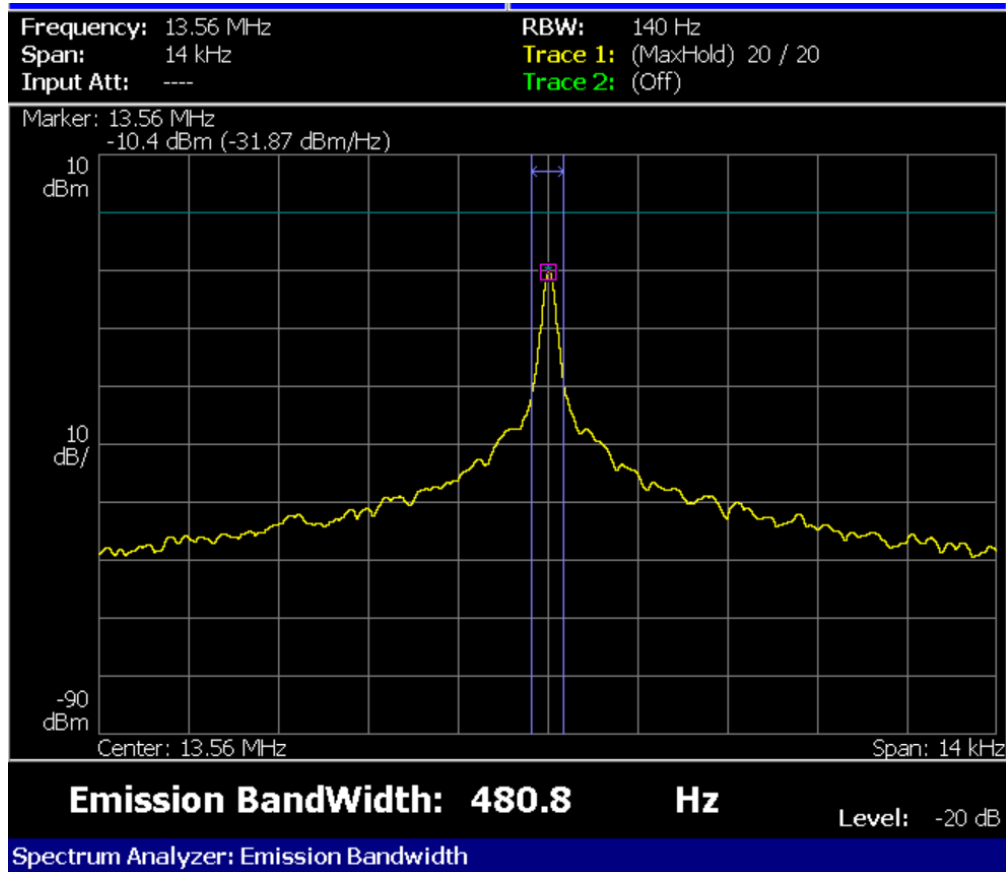

**Figure B-9: Measurement results for 20dB Bandwidth**

### B.5.7. Measurement Uncertainty

Measurement uncertainty:  $U = 77 \text{ Hz}$ ,  $k=2$

## **B.6. Conducted emission**

### **B.6.1. Reference**

See Clause 6.2 of ANSI C63.10-2013 specifically.

See Clause 4 and Clause 5 of ANSI C63.10-2013 generally.

### **B.6.2. Measurement Methods**

The conducted emissions from the AC port of the EUT are measured in a shielding room. The EUT is connected to a Line Impedance Stabilization Network (LISN). An overview sweep with peak detection was performed. The measurements were performed with a quasi-peak detector and if required, an average detector.

The conducted emission measurements were made with the following detector of the test receiver:

Quasi-Peak / Average Detector.

The measurement bandwidth is:

**Table B-9: Measurement Bandwidth**

Frequency of Emission (MHz)	RBW/VBW
0.15-30	9kHz

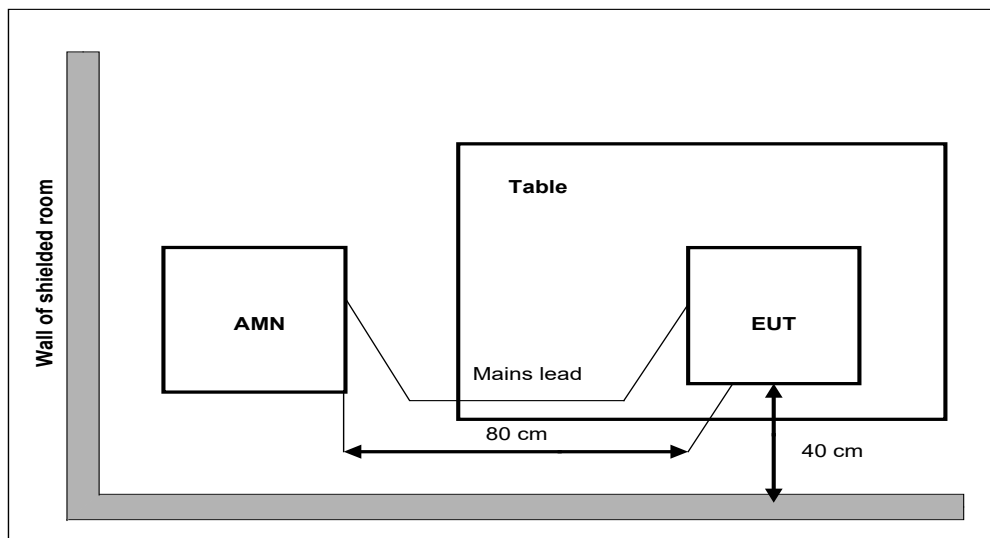

**Figure B-10: Measurement Setup**

### B.6.3. EUT Operating Mode and Test Conditions

The measurement of EUT is carried out under the transmit state of NFC(See 3.4).

The EUT is powered by a travel adapter.

All possible configurations were investigated and only the worst case is reported.

During the measurements, the ambient temperature is in the range of 15 ~ 25 °C.

### B.6.4. Limits

**Table B-10: Limits**

Frequency range (MHz)	Quasi-peak Limit (dB $\mu$ V)	Average Limit (dB $\mu$ V)
0.15 to 0.5	66 to 56	56 to 46
0.5 to 5	56	46
5 to 30	60	50

### B.6.5. Measurement Results

Measurement results see Figure B-11.

Conclusions: Set.NFC01, **PASS**.

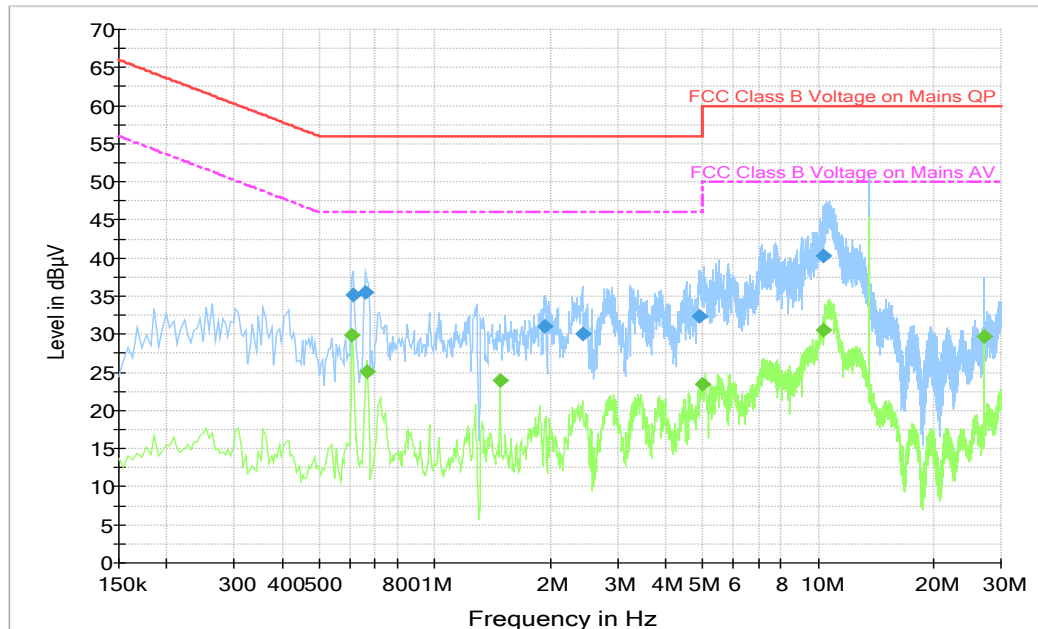

Figure B-11: Measurement results for Conducted Emission

### Final Result 1

Frequency (MHz)	QuasiPeak (dBµV)	Meas. Time (ms)	Bandwidth (kHz)	Line	Corr. (dB)	Margin (dB)	Limit (dBµV)
0.613500	35.2	1000.0	9.000	L1	19.6	20.8	56.0
0.658500	35.5	1000.0	9.000	N	19.5	20.5	56.0
1.927500	31.1	1000.0	9.000	N	19.5	24.9	56.0
2.427000	30.0	1000.0	9.000	L1	19.6	26.0	56.0
4.915500	32.4	1000.0	9.000	L1	19.8	23.6	56.0
10.315500	40.2	1000.0	9.000	L1	19.9	19.8	60.0

### Final Result 2

Frequency (MHz)	Average (dBµV)	Meas. Time (ms)	Bandwidth (kHz)	Line	Corr. (dB)	Margin (dB)	Limit (dBµV)
0.609000	29.8	1000.0	9.000	L1	19.6	16.2	46.0
0.667500	25.0	1000.0	9.000	L1	19.6	21.0	46.0
1.482000	24.0	1000.0	9.000	L1	19.6	22.0	46.0
4.992000	23.4	1000.0	9.000	L1	19.8	22.6	46.0
10.315500	30.6	1000.0	9.000	L1	19.9	19.4	50.0
27.123000	29.7	1000.0	9.000	L1	20.2	20.3	50.0

## **ANNEX C: Persons involved in this testing**

Table C-1: Persons involved

<b>Test Item</b>	<b>Tester</b>
20dB Bandwidth	Zhou Bin
Frequency Tolerance	Zhou Bin
Electric Field Strength of Fundamental and Outside the Allocated bands	Zhang Tianli
Electric Field Radiated Emissions (< 30MHz)	Zhang Tianli
Electric Field Radiated Emissions ( $\geq 30$ MHz)	Ding Zai
Conducted Emissions	Yang Mengke

## **ANNEX D: Accreditation Certificate**

<p><b>United States Department of Commerce National Institute of Standards and Technology</b></p> <p><b>NVLAP</b> </p> <hr/> <p><b>Certificate of Accreditation to ISO/IEC 17025:2017</b></p> <hr/> <p><b>NVLAP LAB CODE: 600118-0</b></p> <p><b>Telecommunication Technology Labs, CAICT</b> Beijing China</p> <p><i>is accredited by the National Voluntary Laboratory Accreditation Program for specific services, listed on the Scope of Accreditation, for:</i></p> <p><b>Electromagnetic Compatibility &amp; Telecommunications</b></p> <p><i>This laboratory is accredited in accordance with the recognized International Standard ISO/IEC 17025:2017. This accreditation demonstrates technical competence for a defined scope and the operation of a laboratory quality management system (refer to joint ISO-ILAC-IAF Communique dated January 2009).</i></p> <hr/> <p>2020-09-29 through 2021-09-30 <i>Effective Dates</i></p> <p>  <i>For the National Voluntary Laboratory Accreditation Program</i></p>	
---	--

**\*\*\*END OF REPORT\*\*\***