

SIMATIC NET

Industrial Remote Communication - TeleControl SINAUT ST7 station control system

System Manual

Preface

The SINAUT ST7 system

1

Properties of the TIM
modules

2

Network structures,
configuration examples,
installation guidelines

3

Installation, connecting up,
commissioning

4

Technical specifications

5

Certifications and approvals

6

Accessories

A

References

B

Volume 1: System and Hardware

Legal information

Warning notice system

This manual contains notices you have to observe in order to ensure your personal safety, as well as to prevent damage to property. The notices referring to your personal safety are highlighted in the manual by a safety alert symbol, notices referring only to property damage have no safety alert symbol. These notices shown below are graded according to the degree of danger.

DANGER

indicates that death or severe personal injury **will** result if proper precautions are not taken.

WARNING

indicates that death or severe personal injury **may** result if proper precautions are not taken.

CAUTION

indicates that minor personal injury can result if proper precautions are not taken.

NOTICE

indicates that property damage can result if proper precautions are not taken.

If more than one degree of danger is present, the warning notice representing the highest degree of danger will be used. A notice warning of injury to persons with a safety alert symbol may also include a warning relating to property damage.

Qualified Personnel

The product/system described in this documentation may be operated only by **personnel qualified** for the specific task in accordance with the relevant documentation, in particular its warning notices and safety instructions. Qualified personnel are those who, based on their training and experience, are capable of identifying risks and avoiding potential hazards when working with these products/systems.

Proper use of Siemens products

Note the following:

WARNING

Siemens products may only be used for the applications described in the catalog and in the relevant technical documentation. If products and components from other manufacturers are used, these must be recommended or approved by Siemens. Proper transport, storage, installation, assembly, commissioning, operation and maintenance are required to ensure that the products operate safely and without any problems. The permissible ambient conditions must be complied with. The information in the relevant documentation must be observed.

Trademarks

All names identified by ® are registered trademarks of Siemens AG. The remaining trademarks in this publication may be trademarks whose use by third parties for their own purposes could violate the rights of the owner.

Disclaimer of Liability

We have reviewed the contents of this publication to ensure consistency with the hardware and software described. Since variance cannot be precluded entirely, we cannot guarantee full consistency. However, the information in this publication is reviewed regularly and any necessary corrections are included in subsequent editions.

Preface

Validity of the manual

This manual is valid for the following Ethernet TIM modules:

- **TIM 3V-IE**
Article number 6NH7800-3BA00
- **TIM 3V-IE Advanced**
Article number 6NH7800-3CA00
- **TIM 4R-IE**
Article number 6NH7800-4BA00

Hardware revision level 4

Firmware version V2.7

Communication module for SIMATIC S7-300 and S7-400, SINAUT ST7 protocol

For the required software versions, see the "Software requirements" section.

Article number, hardware revision level and MAC addresses are engraved on the enclosure.

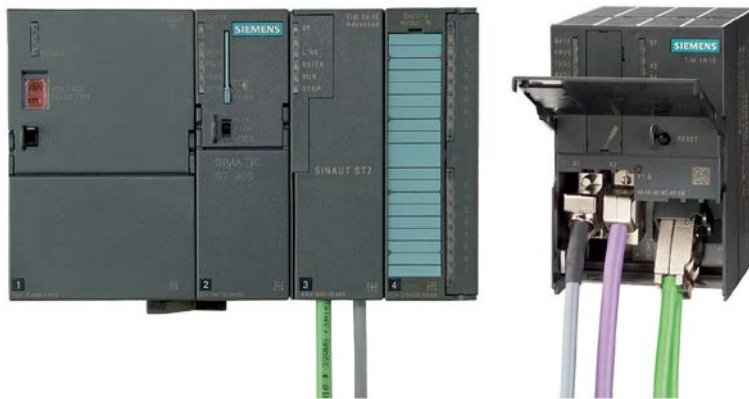

Figure 1 SIMATIC S7-300 with TIM 3V-IE Advanced (left) and TIM 4R-IE (right)

The following communication modules of the SINAUT ST7 telecontrol system are not described in this system manual:

- TIM 1531 IRC
- CP 1243-8 IRC
- CP 1542SP-1 IRC
- RTU3000

Links to the manuals of these modules can be found in the bibliography in the appendix. There you will also find links to the manuals of the SINAUT ST7cc and SINAUT ST7sc control center systems.

Purpose of the manual

This system manual describes the properties of the TIM modules listed above. It shows application examples and supports you in installation, connection, commissioning, configuration and diagnostics of the devices.

Structure of the system manual

The SINAUT ST7 System Manual is divided into three volumes.

- **Volume 1: System & Hardware**

Volume 1 introduces you to the SINAUT ST7 station control system and gives you an overview of the current hardware components.

You will be supported during the planning of network structures and topologies and will see how to install and commission SINAUT components based on the installation guidelines.

In the foreword of Volume 1, you can also find an overview of discontinued products of the SINAUT family with the corresponding editions of this system manual.

- **Volume 2: Software (1)**

Volume 2 describes the configuration and diagnostics of TIM modules in STEP 7 V5.

- **Volume 3: Software (2)**

Volume 3 describes the configuration and diagnostics of TIM modules in STEP 7 Professional (TIA Portal).

What's new?

- **Documentation**

Volume 3 has been added to the system manual to describe the configuration in STEP 7 Professional (TIA Portal).

- **Configuration in STEP 7 Professional**

The Ethernet TIM modules can be configured as of firmware version V2.6 in STEP 7 Professional (TIA Portal).

Configuration is supported as of STEP 7 Professional V15.

- **SINAUT Engineering Software**

New functions of the SINAUT engineering software in the version specified below ("Software requirements" section), including:

Configuration of proxy modules for the transfer of the configuration data to the STEP 7 Professional projects:

- PROXY CP1243-8 IRC based on a TIM 3V-IE Advanced
- PROXY TIM 1531 IRC based on a TIM 4R-IE

You can find information in the section Modules for new SINAUT projects and those to be expanded (Page 22).

Support of Windows 10

- **Block library TD7onCPU for STEP 7 Professional**
The TD7onCPU programming blocks are available for STEP 7 Professional V15 in the library version V3.
- **TIM Firmware**
The new functions are supported as of firmware version V2.6.

Replaced documentation

This manual replaces the manual edition 09/2016.

Current manual release on the Internet

You can find the current version of this manual on the Internet pages of Siemens Industry Online Support:

Link: (<https://support.industry.siemens.com/cs/ww/en/ps/21771/man>)

For older releases of the manual, see below, section Version history (Page 9).

Further information on the Internet

You will find further information on the TeleControl ST7 products on the Internet at the following address:

Link: (<https://support.industry.siemens.com/cs/ww/en/ps/15915>)

There, select the required information under "Entry type".

Sources of information and other documentation

You can find an overview of further reading and references in the Appendix of this manual.

Product names and abbreviations

- **TIM / module / Module / Device**
The names are used for all three TIM versions.
- **STEP 7**
The product name is used in the respective context for the configuration tool STEP 7 V5 or STEP 7 Professional.
- **PG**
Programming device, PC with the STEP 7 V5 project.
- **ES**
Engineering station, PC with the STEP 7 Professional project.

Cross references

In this manual there are often cross references to other sections.

To be able to return to the initial page after jumping to a cross reference, some PDF readers support the command <Alt>+<left arrow>.

Software requirements

The following software versions are required for configuration and online functions of the TIM modules described in this document. You can use the following systems as an alternative:

- **STEP 7 V5**

Required software:

- STEP 7 V5.6
together with
- SINAUT engineering software V5.5 + SP3

For TD7onCPU:

- When using TD7onCPU, the SINAUT TD7 library for the V2.2 + SP4 + HF1 CPU must also be installed along with the SINAUT engineering software.

You can find the description of the configuration in Volume 2 of the system manual.

- **STEP 7 Professional (TIA Portal)**

Required software:

- STEP 7 Professional Version V15
Configuration with limited functions is possible as of STEP 7 Professional V14.0 SP1 Update 1.

For TD7onCPU:

- You can download the associated SINAUT TD7 library V3.0 for the CPU, which can be used for STEP 7 Professional version V15 or later, from the Web pages of Siemens Industry Online Support:
Link: (<https://support.industry.siemens.com/cs/ww/en/view/109755374>)

You can find the description of the configuration in Volume 3 of the system manual.

Compatible CPUs

You can find the CPU types, which can be used together with the respective TIM module, in the section Installation guidelines and compatible CPUs (Page 61).

Security information

Siemens provides products and solutions with industrial security functions that support the secure operation of plants, systems, machines and networks.

In order to protect plants, systems, machines and networks against cyber threats, it is necessary to implement – and continuously maintain – a holistic, state-of-the-art industrial security concept. Siemens' products and solutions constitute one element of such a concept.

Customers are responsible for preventing unauthorized access to their plants, systems, machines and networks. Such systems, machines and components should only be connected to an enterprise network or the internet if and to the extent such a connection is necessary and only when appropriate security measures (e.g. firewalls and/or network segmentation) are in place.

Additionally, Siemens' guidance on appropriate security measures should be taken into account. For additional information on industrial security measures that may be implemented, please visit

Link: (<http://www.siemens.com/industrialsecurity>)

Siemens' products and solutions undergo continuous development to make them more secure. Siemens strongly recommends that product updates are applied as soon as they are available and that the latest product versions are used. Use of product versions that are no longer supported, and failure to apply the latest updates may increase customers' exposure to cyber threats.

To stay informed about product updates, subscribe to the Siemens Industrial Security RSS Feed under

Link: (<http://www.siemens.com/industrialsecurity>)

License conditions

Note

Open source software

Read the license conditions for open source software carefully before using the product.

You will find license conditions in the following documents on the supplied data medium:

- OSS_TIM-3VIE_99.pdf
- OSS_TIM-4RIE_99.pdf
- OSS_SINAUT-ES_99.pdf

Discontinued products

Note

Discontinuation of modules (product discontinuation)

Note the following products to be discontinued.

If there are successors to the discontinued devices, you can find these in the notifications on the Internet.

- The following products have the status "discontinued" as of 15 April 2015:
 - TIM 4R (6NH7800-4AA90)
 - TIM 4RD (6NH7800-4AD90)

Read the product notifications about this on the Internet:

Link: (<https://support.industry.siemens.com/cs/ww/en/view/109475169>)

- As of 01.10.2016 the following products have the status "discontinued":
 - Modem MD2
 - Modem MD3
 - LTOP1 / LTOP2 and accessories

Observe the product notifications on the Internet:

Link: (<https://support.industry.siemens.com/cs/ww/en/view/109740147>)

- EGPRS router MD741-1

Read the product notifications about this on the Internet:

Link: (<https://support.industry.siemens.com/cs/ww/en/view/62607452>)

Documentation 09/2016 for TIM 4R / TIM 4RD and accessories

This edition of the system manual no longer contains information on the TIM 4R and TIM 4RD modules.

For information on these products, refer to the 09/2016 edition of the system manual, which is available on the Siemens Industry Online Support website:

- Volume 1

Link: (<https://support.industry.siemens.com/cs/ww/en/view/109745599>)

- Volume 2

Link: (<https://support.industry.siemens.com/cs/ww/en/view/109748055>)

Documentation 05/2007 for SINAUT ST1 and older ST7 modules

This release of the system manual no longer has information on the SINAUT ST1 system and the following older modules:

- All previous TIM 3 modules: TIM 3V, TIM 32, TIM 33, TIM 34
- TIM 4V, TIM 4VD, TIM 42, TIM 42D, TIM 43, TIM 43D, TIM 44, TIM 44D

If you require information on these modules or on SINAUT ST1, refer to Edition 05/2007 of this manual, which you can find on the website of Siemens Industry Online Support:

- Volume 1

Link: (<https://support.industry.siemens.com/cs/ww/en/view/24621696>)

- Volume 2

Link: (<https://support.industry.siemens.com/cs/ww/en/view/63112659>)

You can find an overview of the products in the section Hardware components (Page 19).

Recycling and disposal



The product is low in pollutants, can be recycled and meets the requirements of the WEEE directive 2012/19/EU "Waste Electrical and Electronic Equipment".

Do not dispose of the product at public disposal sites. For environmentally friendly recycling and the disposal of your old device contact a certified disposal company for electronic scrap or your Siemens contact.

Keep to the local regulations.

You will find information on returning the product on the Internet pages of Siemens Industry Online Support:

Link: (<https://support.industry.siemens.com/cs/ww/en/view/109479891>)

SIMATIC NET glossary

Explanations of many of the specialist terms used in this documentation can be found in the SIMATIC NET glossary.

You will find the SIMATIC NET glossary here:

- SIMATIC NET Manual Collection or product DVD

The DVD ships with certain SIMATIC NET products.

- On the Internet under the following address:

Link: (<https://support.industry.siemens.com/cs/ww/en/view/50305045>)

A SINAUT-specific glossary can be found in the appendix of this manual.

Training, Service & Support

You will find information on training, service and support in the multilanguage document "DC_support_99.pdf" on the Internet pages of Siemens Industry Online Support:

Link: (<https://support.industry.siemens.com/cs/ww/en/view/38652101>)

Version history

The previous versions of the manual described the innovations and versions listed below.

Edition 09/2016 of the manual (C79000-G89xx-Cxxx-10)

New functions:

- **Engineering software**

New version of the SINAUT engineering software V5.5 SP2, can be used under STEP 7 as of version V5.4 SP4:

- Configuration of a PROXY CP1243-8 IRC module based on a TIM 3V-IE Advanced
The 1243-8 IRC can be configured in STEP 7 Basic as of version V13.0 SP1.
- Improvement of the selective connection configuration by selecting individual subscribers
- Passing of the key exchange interval to the MODEM MD720 when using the MSCsec protocol
- Errors corrected in the time-of-day synchronization of a TIM by the CPU

- **Block library TD7onCPU**

New version of the block library TD7onCPU V2.2 SP4 + Hotfix 1

- New block "FC-PathStatus" to display the main and substitute path to the remote communications partner.

The block can be used as of version V5.5 SP1 of the engineering software and as of TIM firmware V2.5.4.

- The block library can now be used both in a standalone TIM in an S7-400 and an S7-400H also with only one single CPU (single mode).

Validity of the manual:

- TIM 3V-IE, TIM 3V-IE Advanced, TIM 4R-IE, TIM 4R / 4RD
- SINAUT ST7 configuration and diagnostics software for the PG V5.4
- SINAUT TD7 library for the CPU V2.2 SP2
- SINAUT TIM firmware V4.4.0 for the TIM 4
- SINAUT TIM firmware V2.5 for the TIM 3V-IE variants
- SINAUT TIM firmware V2.5 for the TIM 4R-IE

The new functions of the SINAUT engineering software V5.5 SP2 mentioned above are supported by firmware version V2.5.4 of the Ethernet TIM modules.

Edition 09/2014 of the manual (C79000-G89xx-Cxxx-09)

New functions:

- New version of the SINAUT ST7 configuration and diagnostics software V5.4
 - Time-of-day synchronization of the TIM 4R-IE using NTP
You will find the description in Volume 2 in section 3 (Configuration in STEP 7 > Configuration of TIM modules > "NTP" tab).
 - Synchronization of the TIM time of day by the CPU
You will find the description in Volume 2 in the section 3 (Configuration in STEP 7 > Configuration of the time-of-day synchronization).
 - MSCsec protocol: Secure transfer, authentication with key exchange
You will find the description in Volume 2 in section 2 (Configuration - Overview > GPRS/Internet Communication).
- New firmware version V2.5 for the TIM modules TIM 3V-IE, TIM 3V-IE Advanced, TIM 4R-IE
The functions named above among the innovations of the configuration software are new.

Validity of the manual:

- TIM 3V-IE, TIM 3V-IE Advanced, TIM 4R-IE, TIM 4R / 4RD
- SINAUT ST7 configuration and diagnostics software for the PG V5.4
- SINAUT TD7 library for the CPU V2.2 SP2
- SINAUT TIM firmware V4.4.0 for the TIM 4
- SINAUT TIM firmware V2.5 for the TIM 3V-IE variants
- SINAUT TIM firmware V2.5 for the TIM 4R-IE

Edition 08/2011 of the manual (C79000-G89xx-Cxxx-08)

New functions:

- New version of "SINAUT ST7 configuration and diagnostics software" V5.2
- Version "SINAUT ST7 configuration and diagnostics software" V5.1
- New SINAUT TD7 library V2.2 SP2 for the CPU

Validity of the manual:

- SINAUT ST7 configuration and diagnostics software for the PG V5.2
- SINAUT TD7 library for the CPU V2.2 SP2
- SINAUT TIM firmware V4.4.0 for the TIM 4
- SINAUT TIM firmware V2.3 for the TIM 3V-IE variants
- SINAUT TIM firmware V2.3 for the TIM 4R-IE

Edition 07/2009 of the manual (C79000-G89xx-Cxxx-07)

New functions:

- New version "SINAUT ST7 configuration software for the PG/PC" V5.0
 - The Ethernet TIMs can be configured for communication via the MSC protocol. This allows the use of the GPRS/GSM modem SINAUT MD720-3 even in SINAUT in Internet/GPRS networks. An encrypted connection can be established from an Ethernet TIM to the Internet via a DSL modem.
 - The time slot method can now also be configured with the "SINAUT ST7 configuration software for the PG/PC" as of V5.0 for a master TIM without DCF7 receiver, if a TIM 4R-IE with an Ethernet connection to an ST7cc/ST7sc PC is used as the master TIM.

The configuration software Version V5.0 can be used with STEP 7 as of Version V5.4 Service Pack 4.

The configuration software version V5.0 is supported by the following operating systems:

- Windows XP Professional SP2
 - Windows Server 2003 SP2
 - Windows Vista 32 Bit Ultimate and Business (with or without SP1)
- New firmware version V2.0 for all Ethernet TIM modules
 - The new firmware supports the MSC protocol.

Validity of the manual:

- SINAUT ST7 configuration software for the PG/PC V5.0
- SINAUT TD7 library for the CPU V2.2
- SINAUT TIM firmware V4.3.9 for the TIM 4
- SINAUT TIM firmware V2.0 for the TIM 3V-IE variants
- SINAUT TIM firmware V2.0 for the TIM 4R-IE

Edition 05/2007 of the manual (C79000-G89xx-Cxxx-06)

New functions:

- New product "TIM 4R-IE" for connecting SINAUT via WAN and Ethernet
- New product version "SINAUT ST7 configuration software for the PG/PC" V4.1

Validity of the manual:

- SINAUT ST7 configuration software for the PG/PC V4.1
- SINAUT TD7 library for the CPU V2.2
- SINAUT TIM firmware V4.3.7 for the TIM 3 / TIM 4
- SINAUT TIM firmware V1.2 for the TIM 3V-IE variants
- SINAUT TIM firmware V1.0 for the TIM 4R-IE

Edition 10/2006 of the manual (C79000-G89xx-C178-05)

New functions:

- New product versions
 - SINAUT ST7 configuration software for the PG/PC V4.0
 - SINAUT TD7 library for the CPU V2.2 with new blocks for communication via P-bus
- New hardware for GSM and GPRS
 - GPRS modem MD740-1 for secure packet-oriented communication via GSM mobile phone (GPRS)
 - GSM modem MD720-3 as replacement for the discontinued GSM modem MC45 for establishing dial-up connections via the GSM mobile network; possible as of firmware V1.7.3 of the MD720-3

Validity of the manual:

- SINAUT ST7 configuration software for the PG/PC V4.0
- SINAUT TD7 library for the CPU V2.2
- SINAUT TIM firmware V4.3.7 for the TIM 3 / TIM 4
- SINAUT TIM firmware V1.2 for the TIM 3V-IE variants

Table of contents

	Preface	3
1	The SINAUT ST7 system	17
1.1	Area of application	17
1.2	Components in a SINAUT ST7 system	18
1.2.1	Hardware components	19
1.2.2	Software components	21
1.3	Modules for new SINAUT projects and those to be expanded	22
1.4	Dedicated line and dial-up network modems	24
1.5	Mobile wireless modems and routers	25
1.5.1	Areas of application	25
1.5.2	Requirements for GSM mode	25
1.6	SINAUT ST7cc, the add-on for WinCC	26
1.6.1	Area of application	26
1.6.2	Properties	27
1.7	SINAUT ST7sc SCADA Connect software	28
1.7.1	Area of application	28
1.7.2	Properties	28
2	Properties of the TIM modules	31
2.1	Overview of the TIM versions	31
2.2	Communications services	32
2.3	Security functions	34
2.4	Overview: Connection to LAN / WAN	35
2.5	TIM 3V-IE / TIM 3V-IE Advanced	37
2.5.1	Functions of the TIM 3V-IE versions	37
2.5.2	LEDs of TIM 3V-IE versions	41
2.6	TIM 4R-IE	43
2.6.1	Functions of the TIM 4R-IE	43
2.6.2	LEDs of TIM 4R-IE	46
2.7	Reset button	48
3	Network structures, configuration examples, installation guidelines	51
3.1	Supported network types	51
3.2	Configurations	52
3.2.1	Configurations with IP-based WAN	52
3.2.2	Configurations with classic WAN	57
3.3	Installation guidelines and compatible CPUs	61
3.3.1	Installing the TIM 3V-IE variants in an S7-300	61

3.3.2	Installing the TIM 4R-IE in an S7-300	70
3.3.3	Standalone TIM 4R-IE with an S7-400 or PC	79
4	Installation, connecting up, commissioning.....	85
4.1	Important notes on using the device	85
4.1.1	Notes on use in hazardous areas	86
4.1.2	Notes on use in hazardous areas according to ATEX / IECEx.....	87
4.1.3	Notes on use in hazardous areas according to UL HazLoc	88
4.2	Installation	89
4.2.1	Dimensions of the TIM	89
4.2.2	Mounting position - horizontal / vertical installation	90
4.2.3	Mounting versions	91
4.2.4	Installing the TIM as a CP	91
4.2.5	Installing the TIM 4R-IE as a stand-alone device	92
4.3	Connecting up	92
4.3.1	Connecting the TIM as a CP	92
4.3.2	Connecting the stand-alone TIM 4R-IE	93
4.3.3	Connection of the MD720 to the TIM and antenna	94
4.3.4	Connecting the power supply.....	94
4.4	Configuring and downloading	96
4.5	Startup behavior of the TIM modules.....	96
4.5.1	Startup of the TIM 3V-IE variants.....	96
4.5.2	Startup activities of the TIM 4R-IE	98
5	Technical specifications	101
5.1	Technical specifications of the TIM 3V-IE variants	101
5.2	Technical specifications of the TIM 4R-IE	108
5.3	Current consumption and power loss of the SINAUT ST7 components.....	112
5.4	Interface allocation	114
6	Certifications and approvals	115
A	Accessories	119
A.1	Router SCALANCE M.....	119
A.2	MODEM MD720.....	120
A.3	Mobile wireless antennas.....	121
A.4	Dedicated line and dialup network modems	123
A.5	Connecting cables	123
A.6	Cable for RS-485 connection.....	126
A.7	Ethernet cables	126
A.8	C-PLUG.....	127
B	References	129
	Glossary	133
	Index	147

The SINAUT ST7 system

1.1 Area of application

Process control over WAN and Ethernet

SINAUT® ST7 is a system based on SIMATIC® S7 for fully automatic monitoring and control of process stations that exchange data with another and with one or more control centers over a WAN (wide area network) or Ethernet (TCP/IP).

The control center

The following can currently be used as control centers:

- SIMATIC controllers S7-300 or S7-400. This solution is suitable for less complex control centers, in which only a current image of the process data in the stations is required. By entering commands, setpoints or parameters, it is possible to intervene in the process control of the stations.
- SINAUT ST7cc, the PC control center (single or redundant) based on WinCC. This is a control center system for SINAUT ST7 specially tailored to the event-driven and time-stamped data transmission of the SINAUT system.
- SINAUT ST7sc, the link to control centers of other vendors over OPC. Using the data access interface, the SINAUT telecontrol technology can also interface with the control center systems of other vendors. ST7sc has extensive buffer mechanisms that prevent data loss, for example, if the OPC client fails.

The SINAUT WANs

The following WANs can be used for data transmission:

- Dedicated lines (copper or fiber-optic cables)
- Private wireless networks (optionally with time slots)
- Analog telephone network
- Digital ISDN network
- Mobile networks (GSM)

All networks can be combined as necessary. Redundant paths are also possible. Star, bus (linear) and node structures can be implemented.

SINAUT over Ethernet

SINAUT communication is possible between station and control center and between stations over Ethernet or IP-based networks. This includes transmission using the GPRS service in mobile networks (GSM networks). The prerequisite is continually available connections.

Change-driven data transmission

The SINAUT software in the stations allows change-driven process data exchange with the control center and between the individual CPUs.

Local data storage

One special characteristic of the TIM communications module used in the SINAUT ST7 system is the local storage of data (including time stamp) if there is a problem on the communication link, if a partner fails or to optimize costs on dial-up networks.

Date and time always precise

The date and time of the CPUs can be synchronized across the network with the control station, such as ST7cc, using various mechanisms. The systems therefore always have a precise time of day including standard/daylight-saving time adjustment.

SINAUT remote programming

All the diagnostic and programming functions provided by SIMATIC and SINAUT for station automation and SINAUT communication can be used online beyond Ethernet networks.

Alerting over SMS

The CPUs can transmit event-controlled SMS messages to mobile phones to alert standby personnel. This is supported by both variants of the TD7 software (TD7onCPU and TD7onTIM) although the range of functions is slightly different. This is described in detail in the SINAUT ST7 system manual, volumes 2 and 3.

1.2 Components in a SINAUT ST7 system

The SINAUT ST7 system is based on the SIMATIC S7-300/400 systems and on SIMATIC WinCC or PCS 7 TeleControl. It expands these systems with the SINAUT components listed below which consist of both hardware and software.

1.2.1 Hardware components

Hardware components

The hardware components include:

- **TIM**

The following Ethernet TIMs are available as communication modules:

- TIM 3V-IE
6NH7800-3BA00
- TIM 3V-IE Advanced
6NH7800-3CA00
- TIM 4R-IE
6NH7800-4BA00

- **GSM modem / mobile wireless Internet router**

- MODEM MD720
- Router SCALANCE M800

For details, see Appendix Accessories (Page 119).

- **Connecting cables**

- Test cable for connecting two TIMS via RS-232
6NH7701-0AR
- Connecting cable for connecting a TIM to a MDx modem via RS-232
6NH7701-4AL
- Cable with one end without connector for connecting a TIM to a third-party modem / wireless device via RS-232.
6NH7701-4BN
- Connecting cable for connecting a TIM to MODEM MD720 via RS-232
6NH7701-5AN

For details, see Appendix Accessories (Page 119).

Products available as spare parts

Spare parts are still available for replacements for a limited period of time:

- Classic TIM modules
 - TIM 4R
6NH7800-4AA90
 - TIM 4RD
6NH7800-4AD90
 - Classic MDx modems
 - MD2 for dedicated line
6NH7810-0AA20
 - MD3 for analog dial-up networks
6NH7810-0AA30
 - MD4 for ISDN dial-up networks
6NH7810-0AA40
- For details, see Appendix Accessories (Page 119).
- LTOP overvoltage protection modules
 - Overvoltage protection module
6NH9821-0BB00
 - LTOP1
6NH9821-0BC11
 - LTOP2
6NH9821-0BC12
 - Radio clock components
 - DCF7 antennas
6NH9831-0AA / -0BA / -0DA
 - Lightning protection for DCF7 antennas
6NH9831-2AA / -8LA
 - GPS components
 - GPS Kit
6NH9831-8AA
 - Connecting cable
6NH7701-4PM
 - 4-way transformer
6NH9821-4GA

- Connecting cables:
 - Connecting cable for connecting a TIM to a MDx modem via RS-485
6NH7701-4DL
 - Cable for connecting two MD2 modems (RS-232) to form a repeater.
6NH7701-1CB

Discontinued products

Connecting cables no longer available as spare parts:

- TIM adapter cable for DCF 77 connection
6NH7700-0AD15
- Connecting cable for TIM 4R/4RD
6NH7700-0AS05
- Connecting cable for connecting TIM 32/42 / MD1 / MD2 to LTOP
6NH7700-0AR60
- Connecting cable for connecting TIM 33/43 / MD3 to TAE6 / LTOP
6NH7700-3BR60
- Connecting cable for connecting TIM 34/44 / MD4 to S₀ interface
6NH7700-4AR60

When ordering the respective devices (as spare parts), the corresponding discontinued connecting cables are included in the delivery.

1.2.2 Software components

Configuration software

Alternatively, you can use it for configuration and diagnostics as well as for SINAUT communication:

- **STEP 7 V5 - SINAUT Engineering Software**
 - SINAUT Engineering Software running under STEP 7 V5 contains:
 - SINAUT ST7 configuration and diagnostic software for the programming device
 - TD7onTIM: TD7 program blocks on the TIM (no memory required on the CPU)
 - TD7onCPU: The TD7 program block library for the CPU (alternative to TD7onTIM)
 - SINAUT Engineering Software is documented in Volume 2 of this system manual.

- **TIA Portal - STEP 7 Professional**

Use STEP 7 Professional in the TIA Portal for configuration and diagnostics.

The functions for ST7 communication can also be used:

- TD7onTIM: Configuring functions in STEP 7 Professional
 - TD7onCPU: The TD7 program block library for the CPU (alternative to TD7onTIM)
- Configuration is documented in Volume 3 of this system manual.

You can find the required software versions in the section Preface (Page 3).

Control center software

- **SINAUT ST7cc**

Expansion package for WinCC consisting of:

- ST 7 Server, the interface between ST7 and WinCC
- ST7cc Config, the configuration tool for ST7cc.

- **SINAUT ST7sc**

SCADA Connect software, consisting of:

- OPC server, the interface between ST7 and an OPC client.
- ST7sc Config, the configuration tool for ST7sc.

For the manuals see /5/ (Page 130) and /6/ (Page 130).

1.3 Modules for new SINAUT projects and those to be expanded

New SINAUT projects in the TIA Portal

For new SINAUT projects, the following modules can be configured in STEP 7 Basic / Professional V15 (TIA Portal) without pre-configuration in STEP 7 V5.

Table 1- 1 Configuring modules in STEP 7 Basic / Professional

Module name (firmware version)	Usable modules in STEP 7 Basic / Professional as of V15	
	Catalog module	STEP 7 version
TIM 3V-IE (V2.6)	TIM 3V-IE	STEP 7 Professional
TIM 3V-IE Advanced (V2.6)	TIM 3V-IE Advanced	STEP 7 Professional
TIM 4R-IE (V2.6)	<ul style="list-style-type: none"> • TIM 4R-IE • TIM 4R-IE Stand-alone 	STEP 7 Professional
CP 1243-8 IRC (V3.0)	CP 1243-8 IRC	STEP 7 Basic
TIM 1531 IRC (V1.0)	TIM 1531 IRC	STEP 7 Professional
CP 1542SP-1 IRC (V2.0)	CP 1542SP-1 IRC	STEP 7 Professional

Extension of existing SINAUT projects in the TIA Portal

SINAUT projects with TIM modules for the SIMATIC S7-300 and S7-400 series, which were configured in STEP 7 V5, can be extended with communication modules of the S7-1200/1500 series which are configured in STEP 7 Basic or STEP 7 Professional in the TIA Portal.

The following modules are available as communication modules for expanding existing SINAUT systems:

- CP 1243-8 IRC
As of STEP 7 Basic V13.0 SP1
- TIM 1531 IRC
As of STEP 7 Professional V15

To avoid having to create, configure and program the entire STEP 7 V5 project in STEP 7 Professional, the STEP 7 V5 project can be expanded by S7-1200/1500 stations with compatible communication modules.

The procedure for configuration of a communication module for the expansion is as follows:

1. Configuration of a placeholder (proxy) for an S7-1200/1500 module in the STEP 7 V5 project

The proxy receives the SINAUT-specific communication, connection and address parameters.

2. Export the configuration data (SDBs) of the proxy from STEP 7 V5 as a text file.
3. Import the configuration data of the proxy into a compatible module in STEP 7 Basic / Professional.

The new module adopts the SINAUT-specific communication, connection and address parameters from STEP 7 V5.

4. Complete the configuration of the new module in STEP 7 Basic / Professional.

This procedure is supported by the following modules:

Table 1- 2 Module migration from STEP 7 V5 to STEP 7 Basic / Professional (TIA Portal)

Module function for STEP 7 V5 project expansion			S7-1200/1500 module in STEP 7 Basic / Professional	
TIM (function) for expansion	Proxy to be used in the catalog		Compatible module	Required STEP 7 version
TIM 3V-IE Advanced	PROXY CP1243-8 IRC	⇒	CP 1243-8 IRC	STEP 7 Basic
TIM 4R-IE	PROXY TIM 1531 IRC	⇒	TIM 1531 IRC	STEP 7 Professional
TIM 4R-IE Stand-alone	PROXY TIM 1531 IRC	⇒	TIM 1531 IRC	STEP 7 Professional

Note

TIM 4R-IE Stand-alone for S7-400 becomes TIM 1531 IRC

A TIM 4R-IE Stand-alone required in STEP 7 V5 that is assigned to a CPU-400 must be replaced by a TIM 1531 IRC for the expansion of classic SINAUT projects in STEP 7 Professional.

A TIM 4R-IE Stand-alone can only be created in new projects that are configured exclusively in STEP 7 Professional.

You can find details on configuration in the section AUTOHOTSPOT.

1.4 Dedicated line and dial-up network modems

Modems for dedicated line and dialup networks

Note

Discontinuation of modules

The following products have the product status "type discontinued" but if they exist can be operated with the communications module:

- Modem MD2
Dedicated line modems
Product notification on the Internet:
Link: (<https://support.industry.siemens.com/cs/ww/en/view/109740149>)
 - Modem MD3
Modems for analog dialup networks
Product notification on the Internet:
Link: (<https://support.industry.siemens.com/cs/ww/en/view/109740148>)
 - Modem MD4
Modems for ISDN networks
Product notification on the Internet:
Link: (<https://support.industry.siemens.com/cs/ww/en/view/67637816>)
-

When using the serial interface for dedicated line and dialup networks, use suitable products of other vendors.

1.5 Mobile wireless modems and routers

1.5.1 Areas of application

Options for data transmission via mobile phone with SINAUT

Wherever no other transmission medium such as a dedicated line or telephone network is available and where the setting up of a separate wireless network would involve high costs, data transmission using a mobile network is a practical alternative.

This is, of course, possible only when there is an adequately strong GSM signal at the relevant location. The latest SINAUT quadband mobile phone modem makes operation in the GSM networks available worldwide (850, 900, 1800 and 1900 MHz range).

SINAUT ST7 provides two options for data transmission over mobile phone:

- **MODEM MD720**

- Data transmission on an "as necessary" basis by establishing a dial-up connection via a mobile network (CSD: Circuit Switched Data)

Dial-up connections are charged on a pay-by-time basis.

- Data transmission with GPRS in a mobile network

Authentication and encryption are based on the MSC protocol. Charges are generally on a pay-by-volume basis.

With both transmission methods, the transmission of SMS messages to standby personnel is also possible. Charges are based on the number of sent SMS messages.

For the manual see /3/ (Page 130).

- **SCALANCE M870 (M874/M876)**

With a 2.5G or 3G router, you can establish a permanent connection between the station and the control center via mobile wireless. Data can be transmitted immediately at any time.

Although permanently online, only the volume of transmitted data is charged.

To communicate with remote devices, the SCALANCE M870 establishes a VPN tunnel and encrypts according to the IPsec protocol.

For the manual see /4/ (Page 130).

1.5.2 Requirements for GSM mode

The following requirements must be met to use the mobile wireless router:

- A subscriber contract with GSM network operator that supports GPRS
- SIM card with activation of the GPRS service

IP address of the partner

To allow the router to establish a VPN connection actively, the partner must have a fixed IP address.

Many Internet service providers, however, assign the IP addresses dynamically; in other words, the IP addresses of the computers or networks with access to the Internet change. A fixed IP address can be obtained in the following ways:

- **Fixed IP address with dedicated line to the GPRS provider**

The partner is connected directly to the GPRS provider over a leased dedicated line. The network provider then normally assigns a fixed IP address.

- **Fixed IP address of the Internet service provider**

The partner is available over the Internet and a fixed IP address has been assigned to it by the Internet service provider. This can be applied for with some providers.

- **Fixed DNS name from dynamic DNS service**

To solve the problem of dynamic IP address assignment, dynamic DNS service can be used. With such a service, the partner can be reached using a fixed domain name regardless of its current dynamic IP address.

Each time the IP address changes, the partner signals the new IP address to the DNS server so that the domain name on the DNS server is always assigned to the current IP address. Use of a dynamic DNS service is subject to entering a contract with a suitable provider.

1.6 SINAUT ST7cc, the add-on for WinCC

1.6.1 Area of application

SINAUT ST7cc is the ideal control center system based on SIMATIC WinCC for SINAUT ST7.

It is specially designed for event-driven and time-stamped data transmission in the SINAUT system. It avoids the possible loss of data that can occur with cyclic polling in WinCC. It also ensures the use of the correct event time supplied by the SINAUT stations for all WinCC messages and archive entries. The process image integrated in ST7cc contains all process data and the status of all SINAUT subscribers in the network. The process image provides WinCC with this data directly for fast transfer to the process image.

The ST7cc Config configuration tool provides fully integrated engineering based on the data frames that were configured in the SINAUT stations. Configuration of WinCC including tag management is therefore generated automatically and updated consistently whenever changes occur.

For archives, protocols and reports that meet the requirements of ATV H260 or Hirthammer, the additional use of the WinCC add-on ACRON is advisable. ST7cc provides a configurable data interface to these add-ons.

Along with the WinCC redundancy package, a redundant ST7cc control center can be implemented.

Refer to the SINAUT ST7cc manual /5/ (Page 130).

1.6.2 Properties

Telecontrol master with user-friendly diagnostics

- Direct connection of SINAUT ST7 TIMs to ST7cc over MPI and Ethernet. An upstream CPU as telecontrol master is not required.
- Availability of the most important status information of each SINAUT subscriber with visualization in WinCC using provided station typicals (picture typicals and faceplates)
- Option of controlling SINAUT subscribers with these faceplates
- Identification of process values from stations with a disrupted connection to ST7cc.
- General request to affected stations following data transfer problems to allow the process image to be updated in ST7cc
- Selective switchable recording of data traffic for individual or all SINAUT subscribers for diagnostic purposes. Frame visualization and evaluation as with the TIM frame monitor.
- Time-of-day synchronization by ST7cc for the TIMs connected to the ST7cc PC over Ethernet

Preprocessing of process data

Preprocessing can be configured for binary, analog, and counted values. This takes into account the event time and adds the time stamp of the event time to related messages and archive entries.

- **Binary values**
 - Entry of current binary values in the assigned WinCC tags
 - Entry of related messages into the WinCC message system taking into account the time stamp supplied by SINAUT
- **Analog values** (instantaneous and mean values)
 - Floating-point numbers, integer values
 - Linear raw value conversion (raw value → physical value)
 - Entry of analog values (with or without linear raw value conversion) in the assigned WinCC tags
 - Entry of analog values (with or without linear raw value conversion) into the WinCC archive taking into account the time stamp supplied by SINAUT
- **Counted values**
 - Overflow handling with absolute counters
 - Counted value scaling using factors
 - Calculation of correctly timed interval quantities
 - Entry of currently accumulating interval quantities in the assigned WinCC tags
 - Entry of completed interval quantities into the WinCC archive taking into account the time stamp supplied by SINAUT

- **Setpoints**
 - Floating-point numbers, integer values
 - Linear raw value conversion (physical value → raw value) when necessary.

Simple, totally integrated project engineering

The configuration of the entire system with ST7ccConfig is very user-friendly. Extra WinCC configuration for the tag management, and the archive and message system is restricted to a few preparations, such as creating message classes and types and archives in WinCC.

1.7 SINAUT ST7sc SCADA Connect software

1.7.1 Area of application

The SINAUT system allows the networking of SIMATIC stations with a control center over a classic or IP-based WAN (Wide Area Network). The control center can also be a SIMATIC station or a PC-based control center, for example, WinCC with the SINAUT ST7cc add-on.

SINAUT ST7sc allows the manufacturers of control systems to connect to SINAUT without needing to integrate a SINAUT interface. Communication is performed over OPC DA: As an OPC server, SINAUT ST7sc forms the interface between the SINAUT system and a control system connected as an OPC client.

The OPC interface is also suitable for data exchange with other applications, for example, the Microsoft Office application Excel.

For the manual see /6/ (Page 130).

1.7.2 Properties

Acquisition of the process data

The SINAUT station acquires the process data when it changes and transfers it via WAN to SINAUT ST7sc. There the received SINAUT data are decoded and stored in the ST7sc tag management according to the configuration. An OPC client can read the received data from the ST7sc tag management synchronously or asynchronously (recommended) via the OPC Data Access Server. With asynchronous reading, the OPC server only transfers the data if changes have occurred in the ST7sc tag management.

In the opposite direction, the OPC client can write data that should be sent to a station (commands, setpoints, parameters) to the ST7sc tag management via the OPC server. The ST7sc tags are converted into SINAUT data frames and sent to the SINAUT stations via WAN.

The item buffering procedure

On special feature of SINAUT systems is the property that process data is backed up to prevent loss. If the connection from the station to the control center fails, the station saves all the data changes detected during the failure locally with a time stamp. This means that connection failures of several hours or days can be bridged without loss of data.

By using item buffering, ST7sc reduces data loss on the way to the OPC client, for example, in the following situations:

- The process image of the OPC DA interface is updated by the SINAUT stations faster than the client can read it.
- The OPC client is temporarily unavailable or the OPC communication line fails.

While ST7sc normally only creates one "memory cell" per item in which the latest status or value of the item is kept ready, with item buffering a buffer is created for each item in which all changes to the item involved are saved in order with a time stamp. These changes are stored until the individual changes can be transferred to the OPC client.

The item buffering requires an HMI application that can process time-stamped data even if the time stamp is already several days old, e.g. after a longer connection failure.

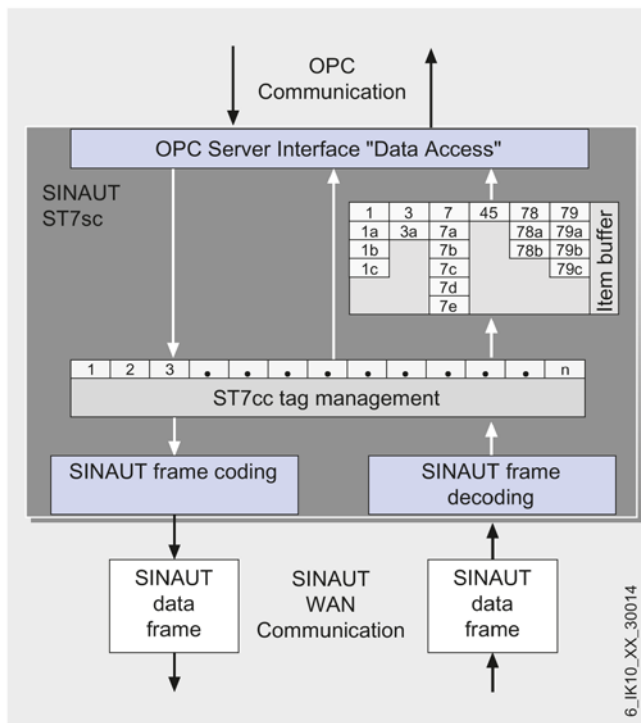

Figure 1-1 System configuration with SINAUT ST7sc

Redundant application

SINAUT ST7sc also allows the connection of a redundant client system. In this case, two ST7sc systems would need to be used. They transfer data received from the stations to both clients in parallel and independently of each other and accept data from them that needs to be sent to the stations.

The redundancy intelligence is at the client end:

- It ensures correct evaluation and comparison of the parallel transferred data.
- It transfers data to be sent to the stations only once to one of the two ST7sc applications so that there is no duplicate transfer.

Configuration

ST7sc is configured using "ST7sc Config", which is included in the ST7sc software package.

Properties of the TIM modules

The central component of the SINAUT hardware is the TIM communications module (Telecontrol Interface Module). This handles the data traffic for the S7-CPU or for the control center PC with the aid of the SINAUT ST7 protocol via the relevant SINAUT network.

The TIM is housed in an S7-300 enclosure and is available in the following versions:

TIM 3V-IE

The TIM 3V-IE is a SINAUT communications module for the SIMATIC S7-300. It has an RS-232 interface to which a suitable modem can be connected. It also has an RJ-45 interface that allows SINAUT communication over IP-based networks (LAN or WAN).

The TIM 3V-IE is available in a standard and advanced version:

- **TIM 3V-IE**

With the TIM 3V-IE, either the Ethernet interface or the RS-232 interface can be used for the SINAUT communication.

- **TIM 3V-IE Advanced**

With the TIM 3V-IE Advanced, the two interfaces can be used at the same time for SINAUT communication. The two transmission paths can be completely independent of each other or form a redundant transmission path.

TIM 4R-IE

The TIM 4R-IE is suitable for installation in a SIMATIC S7-300 as a communications module and can also be connected over Ethernet to one or more SIMATIC S7-400s and to ST7cc or ST7sc PC control centers as a standalone device.

It has two combined RS-232/RS-485 interfaces to which a classic WAN (dedicated line or dial-up network) can be connected via a suitable modem. It also has two RJ-45 interfaces that allow SINAUT communication over Ethernet-based networks (LAN or WAN).

All four interfaces can be used at the same time for SINAUT communication. The four transmission paths can all be different and operated independently. The two pairs of interfaces can also form a redundant transmission path.

2.1 Overview of the TIM versions

The TIM is supplied with a bus connector for installation as a CP in an S7-300 station.

The following table contains a summary of the TIM versions.

Table 2- 1 Overview of the TIM versions

	Can be used in conjunction with		MPI connection	Ethernet port	Serial interface for an external modem	Integrated modem	Article number
	S7-300	S7-400					
TIM 3V-IE	•	no	no	1	1 (RS-232)	no	6NH7800-3BA00
TIM 3V-IE Advanced	•	• *	no	1	1 (RS-232)	no	6NH7800-3CA00
TIM 4R-IE	•	•	no	2	2 selectable (RS-232 / RS-485)	no	6NH7800-4BA00

* The TIM can be connected either via the MPI interface of its S7-300 CPU or via its own Ethernet interface to an S7-400 or to the ST7cc or ST7sc PC.

2.2 Communications services

The following communications services are supported:

Telecontrol communication

Network types

The TIM makes telecontrol communication possible via the following network types:

- Industrial Ethernet
- Dedicated line / wireless network
- Analog dial-up network, ISDN network
- Mobile networks (with the aid of a SCALANCE M router)
 - GSM / GPRS (2G)
 - UMTS (3G) / HSPA+
 - LTE (4G)
- IP-based wireless networks

You will find an overview of the transmission paths and network types in the section Overview: Connection to LAN / WAN (Page 35).

The "SINAUT ST7" protocol

For telecontrol communication via telecontrol networks the TIM uses the ST7 protocol on the application layer (OSI layer 7).

The protocol supports the following functions and services

- **Communication with the control center**

The TIM communicates via LAN or WAN with an application in the master station.

You will find the supported master station types in the section The SINAUT ST7 system (Page 17).

- **Direct communication**

In dial-up networks, mobile networks and Ethernet networks, there is direct communication between the subscribers.

- **Inter-station communication**

In dedicated line networks and with communication via the Internet with a mobile network (GSM/MSC), the TIM supports inter-station communication between S7 stations via the master station.

With inter-station communication, the TIM establishes a connection to the master station. The master station forwards the messages to the destination station.

- **Messages: SMS / e-mail**

When configurable events occur, the TIM can send SMS messages to mobile telephones and e-mails to PCs with an Internet connection.

- SMS messages can be sent if the TIM is connected to a mobile network via the serial interface and a GSM or GPRS module (MODEM MD720).
- If the TIM is connected, e-mails can be sent via the Ethernet interface.

You can find information about addressing in ST7 and about configuration in Volumes 2 and 3 of the system manual.

Protocols with security functions

- **MSC**

For secure telecontrol communication the transmission protocol "MSC" (OSI layer 3) is available. MSC can be used for communication between two TIM modules (not between the TIM and a master station application).

MSC is IP-based and can be used in the following networks:

- Ethernet
- Internet (DSL)
- Mobile network (GSM) and Internet

The following variants of the protocol are available:

- MSC
Simple Internet communication via the Internet (DSL)
- MSCsec
Secure Internet communication when security requirements are higher.

- **IPsec / VPN (via router SCALANCE M)**

VPN stands for highly secure communication via mobile phone and the Internet (DSL) using a SCALANCE M mobile phone router.

For a description of the protocols, refer to the section Security functions (Page 34).

S7 communication

For reading / writing data from and to the local CPU via S7 connections, the following services are supported.

- **PG communication**

Communication with an engineering station

The Ethernet interfaces of the TIM must be configured with the network type "Neutral" for the S7 communications services.

2.3 Security functions

Security functions of the transmission protocols

The transmission protocols that can be used for telecontrol communication support the following security functions:

- **MSC**

The MSC protocol supports authentication of the communications partners and simple encryption of data. A user name and a password are included in the encryption. An MSC tunnel is established between the MSC station and MSC master station.

- **MSCsec**

MSCsec supports authentication of the communications partners and data encryption with a user name and password.

In addition to this, the shared automatically generated key is renewed between the communications partners at a configurable Key exchange interval.

Further security functions of the TIM

The TIM also supports the following security functions:

- **NTP (secure)**

For secure transfer during time-of-day synchronization

Additional protection be using security modules

With Industrial Ethernet Security, individual devices, automation cells or network segments of an Ethernet network can be protected. The following security modules are suitable for connecting the TIM to public networks:

- **SCALANCE M800**

Routers for IP-based data transfer via DSL or mobile networks of the standards GPRS, EGPRS, UMTS, LTE

- **SCALANCE S**

Security modules for connection to Ethernet networks

The data transfer of the TIM along with a security module can be protected from the following attacks by a combination of different security measures:

- Data espionage
- Data manipulation
- Unwanted access

Secure underlying networks can be operated via additional Ethernet interfaces of the TIM or CPU.

Using the security modules mentioned above SCALANCE M / SCALANCE S the following additional security functions can be used:

- **Firewall**
 - IP firewall with stateful packet inspection (layer 3 and 4)
 - Firewall also for "non-IP" Ethernet frames according to IEEE 802.3 (layer 2)
 - Limitation of the transmission speed to restrict flooding and DoS attacks ("Define IP packet filter rules")
 - Global firewall rule sets

- **Protection for devices and network segments**

The protection provided by the firewall can cover individual devices, several devices or even entire network segments.

- **Communication made secure by IPsec tunnels (VPN)**

VPN tunnel communication allows the establishment of secure IPsec tunnels for communication with one or more security modules.

VPN can be used for communication via mobile wireless and the Internet (DSL) along with a SCALANCE M router. The SCALANCE M800 product line includes various VPN routers with encryption software and a firewall.

The router can be put together with other modules to form VPN groups during configuration. IPsec tunnels (VPN) are created between all security modules of a VPN group. All internal nodes of these security modules can communicate securely with each other through these tunnels.

- **Log files**

To allow monitoring, events can be stored in log files that can be read out using STEP 7 Professional or can be sent automatically to a Syslog server.

You will find further information on the functionality and configuration of the security functions in the information system of STEP 7 and in the manual /7/ (Page 131).

2.4 Overview: Connection to LAN / WAN

Transfer options

The interfaces of the TIM support the following network types and protocols:

Ethernet interfaces

- **IP-based**

Communication via LAN (copper / FO cable), Internet and IP-based wireless networks

- Neutral (via S7 connection)
- MSC / MSCsec

For information on the protocol variants, refer to the section Communications services (Page 32).

- Mobile wireless with VPN

IP-based mobile phone communication (with gateway to the Internet) only with SCALANCE M router

Serial interface

- **Classic WAN**

- Dedicated line (incl. analog wireless network)
- Dial-up network (analog, ISDN mobile phone)

- **IP-based**

- MSC / MSCsec via GPRS

Connection combinations of the interfaces

The following table provides an overview of the various connection options of the TIM interfaces and the devices required for them (modems, routers, switches).

The table contains the information for the interfaces of the TIM and for the connection of the communication partner. The protocols or services used are listed.

Network type / transmission path	Connection TIM		Standard, protocol, service	Connection of the partner	Partner type *
	Serial interface	Ethernet interface			
Ethernet	-	SCALANCE M / SCALANCE S	VPN	SCALANCE M / SCALANCE S	<ul style="list-style-type: none"> • PC • TIM
	-	SCALANCE X / W		SCALANCE X / W	<ul style="list-style-type: none"> • PC • TIM
Mobile phone + Internet	-	DSL router	MSC / MSCsec	DSL router	TIM
	-	SCALANCE M	MSCsec	SCALANCE M	TIM
	-	SCALANCE M	VPN	SCALANCE M	TIM
IP wireless network	-	IP wireless modem	IP	IP wireless modem	TIM
Dedicated line	Dedicated line modem	-	RS-232 / RS-485	Dedicated line modem	TIM
	Analog wireless modem			Analog wireless modem	

Network type / transmission path	Connection TIM		Standard, protocol, service	Connection of the partner	Partner type *
	Serial interface	Ethernet interface			
Analog dial-up network	Dial-up network modem	-	V.32bis/V.34bis	Dial-up network modem	TIM
ISDN dial-up network	ISDN modem	-	<ul style="list-style-type: none"> • ISDN • ISDN + GSM/CSD 	<ul style="list-style-type: none"> • ISDN modem • MODEM MD720 	TIM
Mobile network	MODEM MD720	-	GSM/CSD	<ul style="list-style-type: none"> • DSL router • MODEM MD720 	TIM
			GSM + MSC/MSCsec	<ul style="list-style-type: none"> • DSL router 	

* PC: Control center computer with ST7-capable application, for example, SINAUT ST7cc/ST7sc.

You will find information on the accessories in the following sections or literature sections:

- Router SCALANCE M (Page 119)
- Dedicated line and dialup network modems (Page 123)
- MODEM MD720 (Page 120)
- Connecting cables between TIM and modem: Connecting cables (Page 123)
To connect a modem to the TIM a cable must be ordered.
- SCALANCE S: /8/ (Page 131)

2.5 TIM 3V-IE / TIM 3V-IE Advanced

2.5.1 Functions of the TIM 3V-IE versions

The TIM 3V-IE is available in standard and advanced versions. The two communications processors share the following properties:

- TIM without integrated modem, single width
- For installation as a communications processor (CP) in an S7-300
- With a TIM 3V-IE, an S7-300 CPU or a C7 control system can then handle SINAUT communication:
 - Via a classic SINAUT WAN with SINAUT partners
 - Over an IP-based network (WAN or LAN) with SINAUT ST7 subscribers

- It has two interfaces:
 - RS-232 interface for connection of required WAN transmission equipment (classic SINAUT WAN)

To allow use of GPRS, the switchable serial interface of a station TIM 3V-IE can be connected to a GSM network via the MODEM MD720. This requires the MSC protocol to be enabled in the STEP 7 > Properties dialog of the TIM > Interfaces tab. The WAN interface then behaves like an Ethernet interface.
 - RJ-45 interface for attachment to Ethernet

To use both interfaces, see the following table.
- The SINAUT TD7 software is integrated on the TIM (TD7onTIM)
- Modules can be replaced without the need for a programming device

The following properties are different on the TIMs:

	TIM 3V-IE	TIM 3V-IE Advanced
Use of the interfaces for SINAUT communication	RS-232 or RJ45	RS-232 and RJ45, also as redundant transmission path
Use as	<ul style="list-style-type: none"> • Station 	<ul style="list-style-type: none"> • Station • Nodes • Master station
Data memory	16000 data frames	32000 data frames
Number of S7 connections	8	20
Can be combined with other TIMs in the rack	no	yes
Communication over MPI of the S7-300 CPU	no	yes

The following figure shows a TIM 3V-IE.



Figure 2-1 SINAUT TIM 3V-IE communications module

The TIM 3V-IE variants have all the advantages of the SIMATIC S7-300 system design:

- Compact design; single standard width of the SM modules of the SIMATIC S7-300
- 9-pin D-sub male connector with an RS-232 interface for connecting a modem
- RJ-45 jack for connection to Ethernet; industrial design with additional collar for inserting the IE FC RJ-45 Plug 180
- 2-pin plug-in terminal block for connecting the external supply voltage of 24 V DC
- Front LEDs for display of Ethernet and WAN communication
- Easy to mount; the TIM is mounted on the S7-300 rail and connected to adjacent modules by means of the bus connectors. No slot rules apply.
- In conjunction with the IM 360/361 can also be operated in the expansion rack (ER). This allows the TIM to be combined with a C7 control system, with the newer C7 control systems it can also be combined using the supplied I/O expansion cable.
- Can be operated without a fan
- A backup battery or memory module are not required

The following figure shows the connectors of the TIM 3V-IE or TIM 3V-IE Advanced (schematic representation with covers removed).

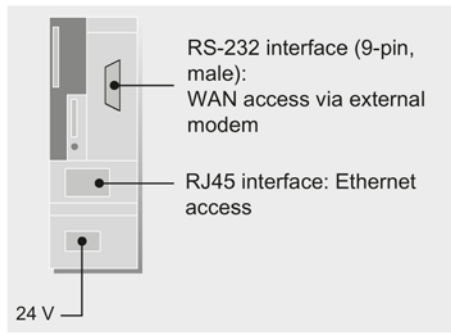

Figure 2-2 Connectors of the TIM 3V-IE or TIM 3V-IE Advanced

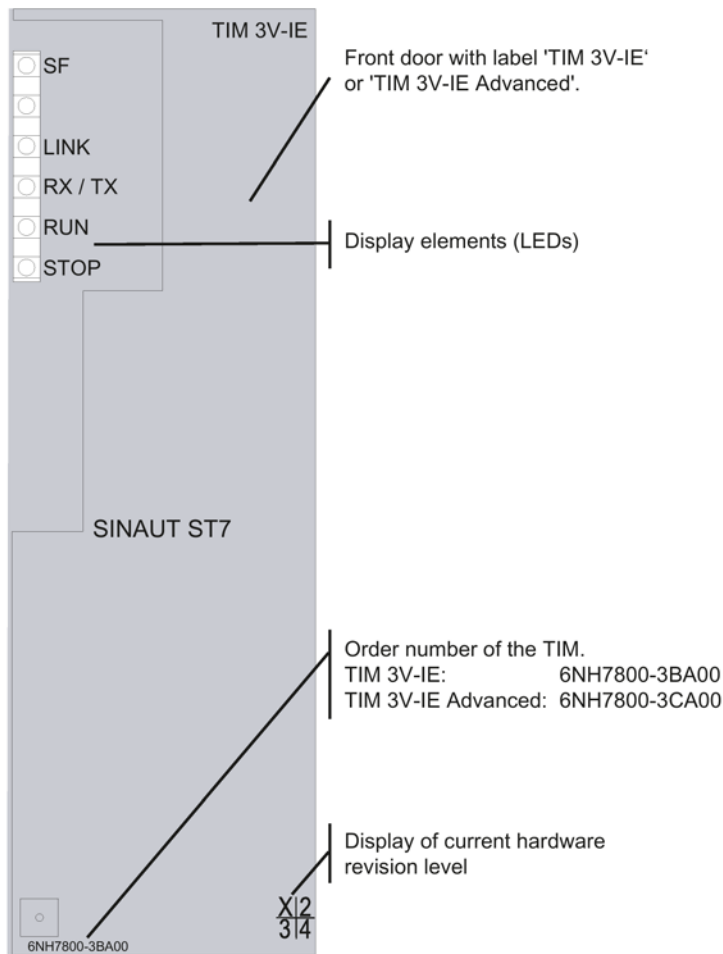

Figure 2-3 Front view of a TIM 3V-IE version with closed front door

The hardware revision level of the device is printed as placeholder "X" (e.g. X 2 3 4). In this case, "X" would be the placeholder for hardware product version 1.

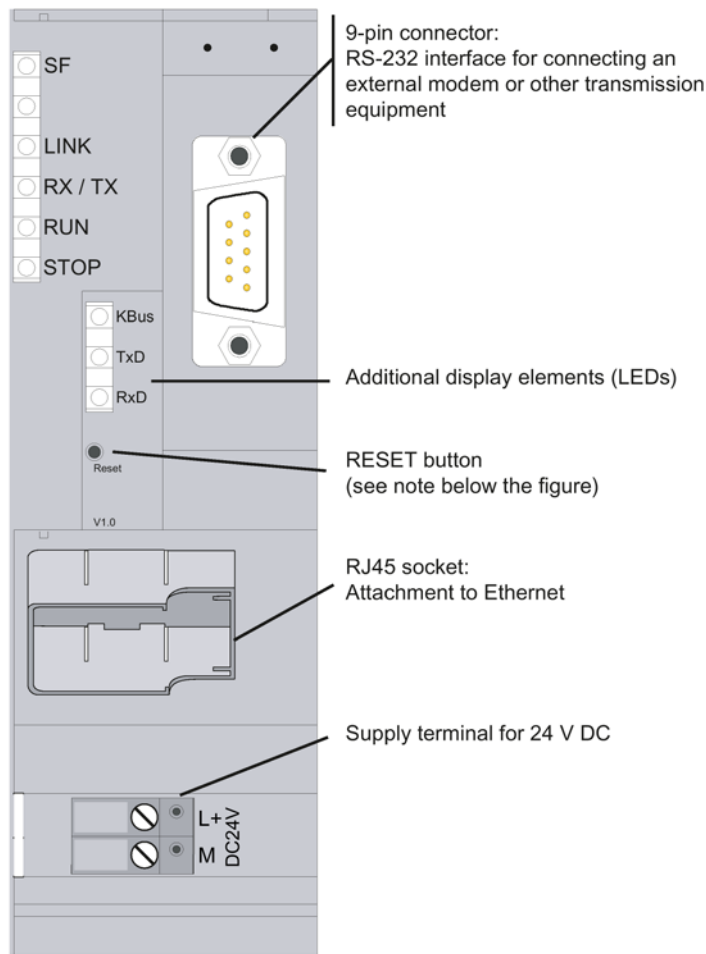

Figure 2-4 Front view of a TIM 3V-IE version with removed front door

See section Reset button (Page 48) for more information on the function of the button.

You can find the pin assignment of the interface in the section Interface allocation (Page 114).

2.5.2 LEDs of TIM 3V-IE versions

The following table summarizes the meaning of the nine LEDs during normal operation.

For the LED pattern during the startup, refer to the section Startup of the TIM 3V-IE variants (Page 96).

Table 2- 2 Meaning of the LEDs on the front panel of the TIM 3V-IE variants

LED no.	Labeling	Relevant TIM interface	Description
1	SF	all	Group error Indicates missing or bad parameter settings and RAM errors.
2	none	-	-
3	LINK	Ethernet	Connection to Ethernet LED is lit if there is a physical connection to Ethernet. LED is off if there is no physical connection to Ethernet.
4	RX/TX	Ethernet	Data flow over Ethernet The display changes with each message received or sent via Ethernet.
5	RUN	-	Module in RUN LED is lit when the module completes startup without error or is switched to RUN mode by the PG. LED is off when the module is switched to STOP mode by the PG.
6	STOP	-	Module in STOP LED is lit when the module is switched to STOP mode by the PG. LED is off when the module is switched to RUN mode by the PG

Table 2- 3 Meaning of the LEDs behind the front panel of the TIM 3V-IE variants

LED no.	Labeling	Relevant TIM interface	Type of WAN driver	Description
7	KBus	MPI / K bus	-	Data flow over MPI / backplane bus The display state changes with each message received or sent over MPI / backplane bus.
8	TxD	RS-232 interface	Dedicated line	Transmit data LED is lit constantly and is off while a message is being sent (TXD).
			Dial-up network	Transmit data No connection established: LED is off. Connection is established: LED is lit constantly and is off while a message is being sent (TXD).
9	RxD	RS-232 interface	Dedicated line	Receive data As long as receive level (DCD) is detected, the LED is lit and goes off while a message is being received (RXD).
			Dial-up network	Receive data Lights up with an incoming call (RI), remains lit as long as receive level (DCD) is detected, and goes off while a telegram is being received (RXD).

2.6 TIM 4R-IE

2.6.1 Functions of the TIM 4R-IE

- TIM without integrated modem, double width
- Has four interfaces:
 - 2 x combined RS-232/RS-485 interface for connection of required WAN transmission equipment (classic SINAUT WAN)

To allow use of GPRS, the switchable serial interface WAN 1 of the TIM 4R-IE can be connected to a GSM network via the GSM modem MD720-3. This requires the MSC protocol to be enabled in the STEP 7 > Properties dialog of the TIM > Interfaces tab. The WAN interface then behaves like an Ethernet interface.
 - 2 x RJ45 interface for attachment to Ethernet
- Compact unit that can be used in a wide variety of situations:
 - as a communications processor (CP) in an S7-300
 - as a standalone device combined with one or more S7-400s or control center PCs (SINAUT ST7cc or ST7sc) over the Ethernet interface
- This allows these devices to handle SINAUT communication:
 - Over any two classic SINAUT WANs with SINAUT partners
 - Over two IP-based networks (WAN or LAN) with SINAUT ST7 subscribers
- All four interfaces can be used at the same time for SINAUT communication.
- The four transmission paths can all be different and operated independently. The two pairs of interfaces can also form a redundant transmission path.
- When installed as a CP in an S7-300, the following communication is also possible:
 - With the CPU
 - Over the MPI interface of this CPU with other CPUs and control center PCs (ST7cc, ST7sc) connected over the MPI bus
 - With other TIMs in this rack
- Message memory for up to 56,000 data messages
- Optional backup battery for backup of the stored data messages and the hardware clock
- Up to 62 S7 connections

2.6 TIM 4R-IE

- The SINAUT TD7 software is integrated on the TIM (TD7onTIM). It can be used when the TIM is installed as a CP in an S7-300.
- Modules can be replaced without a PG:
 - In standalone mode using the optional C-PLUG
 - When installed as a CP in an S7-300 over the MMC of the CPU



Figure 2-5 The SINAUT communications module TIM 4R-IE

The TIM 4R-IE versions have all the advantages of the SIMATIC S7-300 system design:

- Compact design; double standard width of the SM modules of the SIMATIC S7-300
- Two 9-pin D-sub male connectors with a combined RS-232/RS-485 interface for connecting a modem
- Two RJ45 jacks for connection to Ethernet; industrial design with additional collar for inserting the IE FC RJ45 Plug 180
- 2-pin plug-in terminal block for connecting the external supply voltage of 24 V DC
- Front LEDs for display of Ethernet and WAN communication
- Simple mounting; the TIM is installed on an S7-300 rail. If the TIM is installed in an S7-300 as a CP, it is connected to adjacent modules by means of the bus module connectors. No slot rules apply.
- In conjunction with the IM 360/361 can also be operated in the expansion rack (ER). This allows the TIM to be combined with a C7 control system, with the newer C7 control systems it can also be combined using the supplied I/O expansion cable.
- Can be operated without a fan
- A backup battery and a memory module (C-PLUG) can be installed as options.

The following figure shows the connections of the TIM 4R-IE (schematic representation with removed front flap).

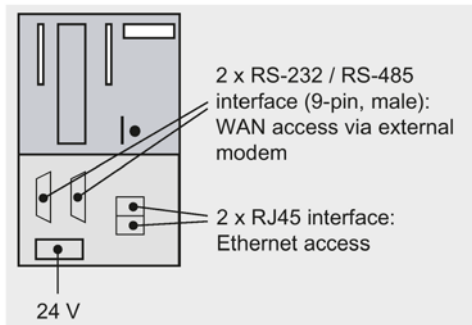

Figure 2-6 I/Os of TIM 4R-IE

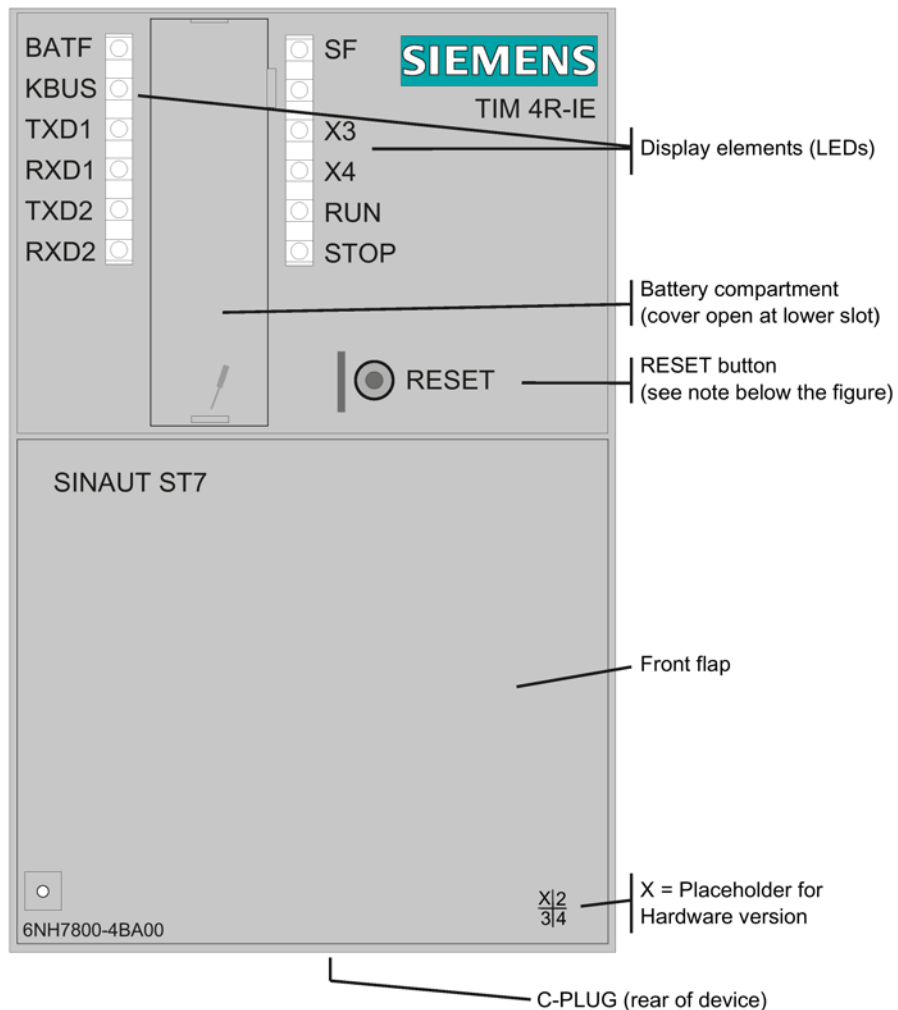

Figure 2-7 Front view of the TIM 4R-IE with closed front panel

The hardware revision level of the device is printed as placeholder "X" (e.g. X 2 3 4). In this case, "X" would be the placeholder for hardware product version 1.

See section Reset button (Page 48) for more information on the function of the button.

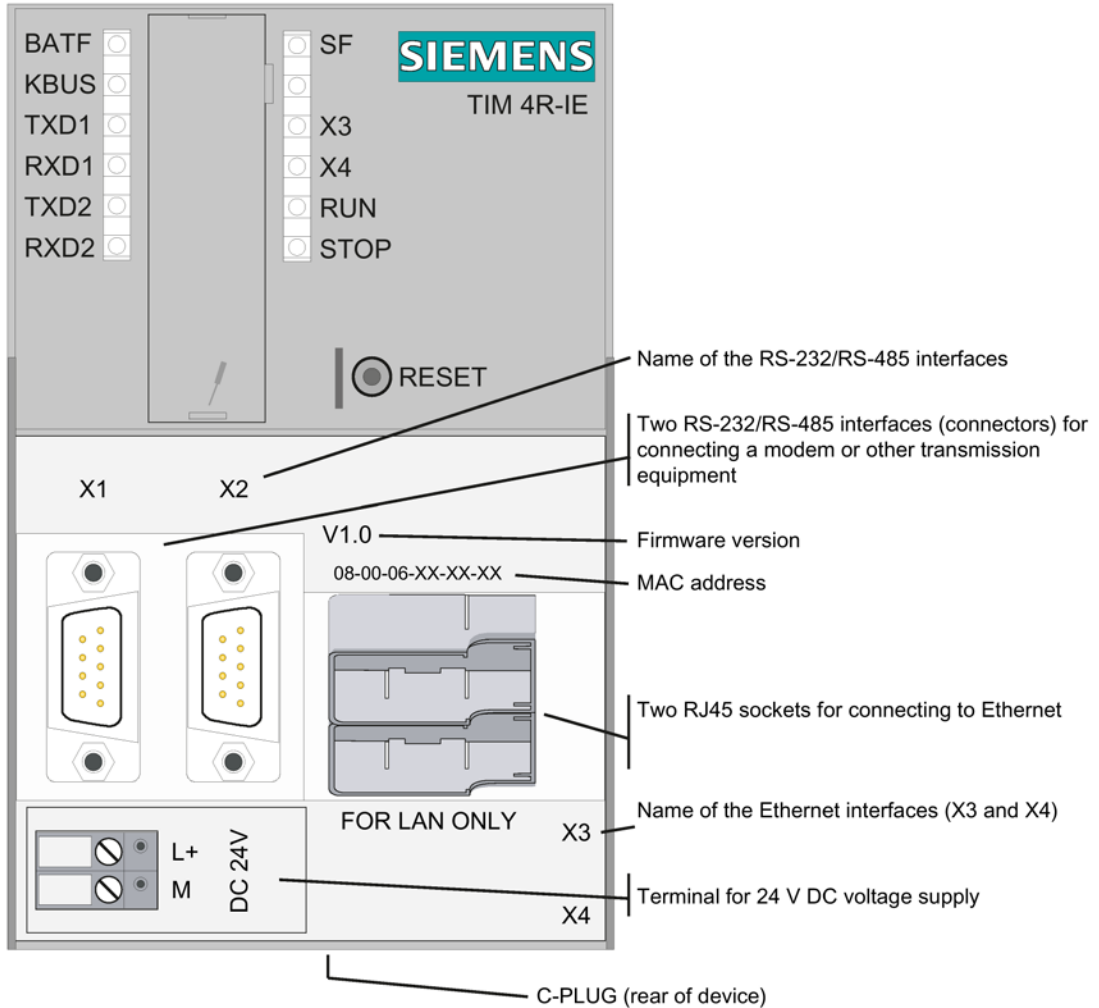

Figure 2-8 Front view of the TIM 4R-IE with front flap removed

On the rear of the housing, there is an opening for the optional C-PLUG. The configuration data of the TIM 4R-IE can be stored on the C-PLUG. If service is required, a standalone TIM can be replaced without needing a PG.

You can find the pin assignment of the interface in the section Interface allocation (Page 114).

2.6.2 LEDs of TIM 4R-IE

The following table summarizes the meaning of the LEDs during normal operation.

For the LED pattern during the startup, refer to the section Startup activities of the TIM 4R-IE (Page 98).

Table 2- 4 Meaning of the LEDs on the front panel of the TIM 4R-IE

LED no.	Labeling	Relevant TIM port	Type of WAN driver	Description
1	BATF	All	-	If there is a functioning battery installed, the LED is off. The LED lights up red if the battery is not inserted in the battery compartment or if the battery voltage is too low.
2	KBus	K bus	-	Data flow over the backplane bus The display state changes with each message received or sent over the backplane bus.
3	TXD1	RS-232 interface 1	Dedicated line	Transmit data LED is lit constantly and is off while a message is being sent (TXD).
			Dial-up network	Transmit data No connection established: LED is off. Connection is established: LED is lit constantly and is off while a message is being sent (TXD).
4	RXD1	RS-232 interface 1	Dedicated line	Receive data As long as receive level (DCD) is detected, the LED is lit and goes off while a message is being received (RXD).
			Dial-up network	Receive data Lights up with an incoming call (RI), remains lit as long as receive level (DCD) is detected and goes off while a message is being received (RXD).
5	TXD2	RS-232 interface 2	Dedicated line	Transmit data LED is lit constantly and is off while a message is being sent (TXD).
			Dial-up network	Transmit data No connection established: LED is off. Connection is established: LED is lit constantly and is off while a message is being sent (TXD).
6	RXD2	RS-232 interface 2	Dedicated line	Receive data As long as receive level (DCD) is detected, the LED is lit and goes off while a message is being received (RXD).
			Dial-up network	Receive data Lights up with an incoming call (RI), remains lit as long as receive level (DCD) is detected and goes off while a message is being received (RXD).

2.7 Reset button

Table 2- 5 Meaning of the LEDs on the right of the front panel of the TIM 4R-IE

LED no.	Labeling	Relevant TIM port	Description
7	SF	All	Group error Indicates missing or bad parameter settings and RAM errors.
8	-	-	-
9	P 1	Ethernet	Connection to Ethernet (interface 1) LED lights up yellow if there is a physical connection to Ethernet. Green flashing LED indicates data flow. LED is off when there is no physical connection to Ethernet.
10	P 2	Ethernet	Connection to Ethernet (interface 2) LED lights up yellow if there is a physical connection to Ethernet. Green flashing LED indicates data flow. LED is off when there is no physical connection to Ethernet.
11	RUN	-	Module in RUN LED is lit when the module completes startup without error or is switched to RUN mode by the PG. LED is off when the module is switched to STOP mode by the PG.
12	STOP	-	Module in STOP LED is lit when the module is switched to STOP mode by the PG. LED is off when the module is switched to RUN mode by the PG.

2.7 Reset button

Reset with the reset button

 WARNING
EXPLOSION HAZARD
Do not press the button if there is a potentially explosive atmosphere.

If there is a situation in which the TIM can no longer be accessed over the MPI interface of the CPU or its own Ethernet interface following startup due to incorrect parameter assignment information, the TIM can be returned to a defined state using the default startup.

Following the default startup, the TIM can be loaded again both over the MPI interface of the CPU and over its own Ethernet interface.

The reset button can be used to force a default startup of the TIM.

Effects of the default startup

Note

Configuration data is deleted

The TIM is reset to factory settings by forcing a default startup. All configuration data in the TIM are deleted!

- **Deleted data**

The following data is deleted by resetting to factory settings:

- Configured IP address of the LAN interface
- All other configuration data in the work memory of the TIM

- **Data not deleted**

The following data is not deleted by resetting to factory settings:

- MAC addresses of the LAN interfaces

Performing the default startup

To force a default startup, follow the steps outlined below:

1. Turn off the power for the TIM.
2. Press the reset button accessible from the front, turn on the power while holding down the reset button.

During hardware initialization (LED phase 1), the SF LED is turned off briefly and then turned on again.

3. Release the reset button at the moment when the RUN LED stops flashing and the SF LED is turned on again.
4. Wait until the startup of the TIM is completed and the default startup is signaled by the LEDs.

For the relevant LED patterns see the following section:

- Startup of the TIM 3V-IE variants (Page 96)
- Startup activities of the TIM 4R-IE (Page 98)

2.7 Reset button

5. Load the TIM with its parameter data (SDBs) over the MPI interface of the CPU or its own Ethernet interface.

Note

New MPI address when mounting the TIM as CP in the rack

If the TIM is installed as a CP in an S7-300 and the CPU is a type with a partyline, then the TIM obtains the MPI address 3 after the default startup.

If another subscriber on the MPI bus already has MPI address 3, a conflict arises. You will then have to disconnect one of the two modules temporarily from the MPI bus to be able to transfer the parameters (including the correct MPI address) to the TIM.

For the "partyline", see Glossary (Page 133).

6. After loading the SDBs, restart the TIM.

The following overview shows you the network structures that can be implemented with SINAUT ST7 in a WAN and on Industrial Ethernet. For each network configuration, you will also see the protocols and modes with which SINAUT can handle communication over the network.

3.1 Supported network types

With SINAUT ST7, complete hierarchical control networks consisting of stations, node stations and master station can be set up over a WAN (Wide Area Network). The following WAN types can be used to exchange information between the individual devices:

IP-based WAN

SINAUT communication is possible between station and control center and between stations over IP-based WANs:

- Over public networks and Internet with DSL or GPRS
- Over wireless using Ethernet wireless devices, e.g. SCALANCE W
- Over fiber-optic cable
 - E. Using SCALANCE X switches with optical ports, for example; this allows distances of up to 120 km to be covered.
 - In conjunction with transmission systems such as PCM30 or OTN

Classic WAN

The following classic WANs can be used for data transmission:

- Dedicated lines, private or leased copper or fiber-optic cable
- Private wireless networks (optionally with time slots)
- Analog telephone network
- Digital ISDN network
- Mobile network GSM

3.2 Configurations

The symbols used in the following configurations represent the various modules with their LAN or WAN interfaces.

Note

Notes on TIM 4 / TIM 4R-IE

- The two WAN interfaces of a TIM 4R / TIM 4RD can both have the same function (for example 2 x master) or different functions (for example node + master).
- With redundant WAN connections, a TIM 4 or TIM 4R-IE with two interfaces must always be used because redundant paths always start and end on a TIM module.

3.2.1 Configurations with IP-based WAN

IP-based network, linking via switches

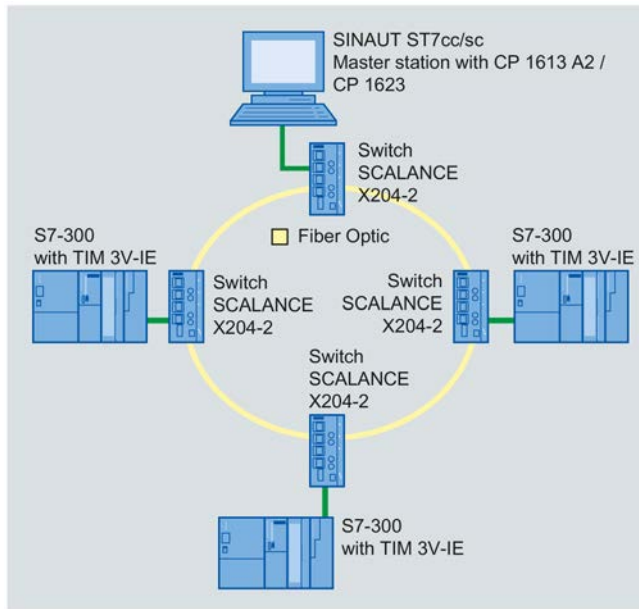

Figure 3-1 IP-based network, linking via switches

Wireless Ethernet communication

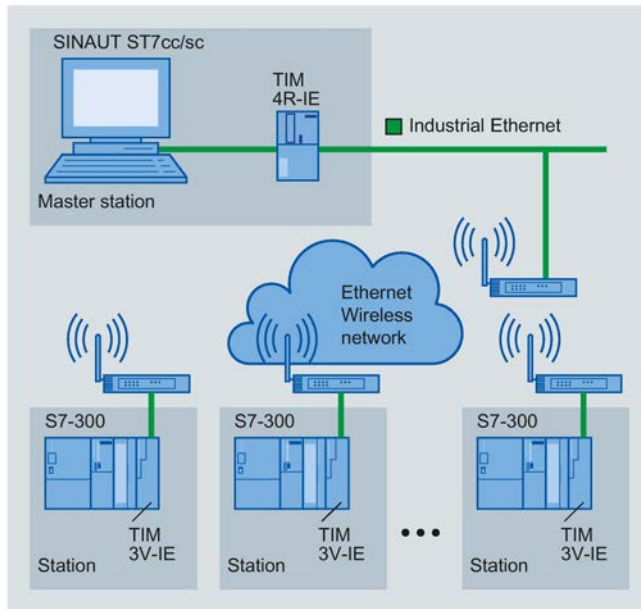

Figure 3-2 Wireless Ethernet communication

Wireless Ethernet communication with TIM 3V-IE in master stations and stations

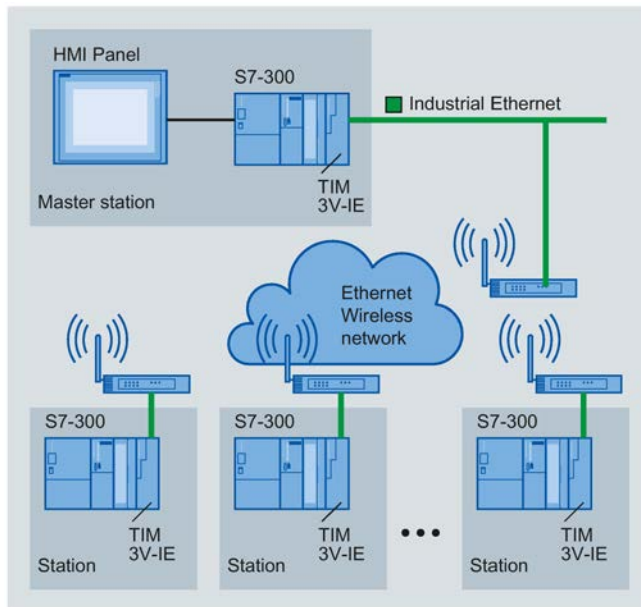

Figure 3-3 Wireless Ethernet communication with TIM 3V-IE in master stations and stations

IP-based communication via DSL

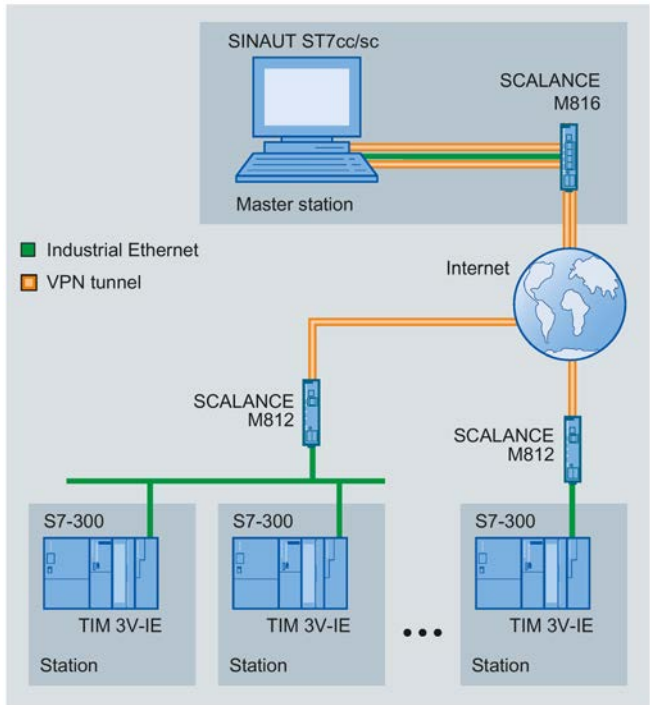

Figure 3-4 IP-based communication via DSL

IP-based communication via GPRS with simple security (simple Internet communication)

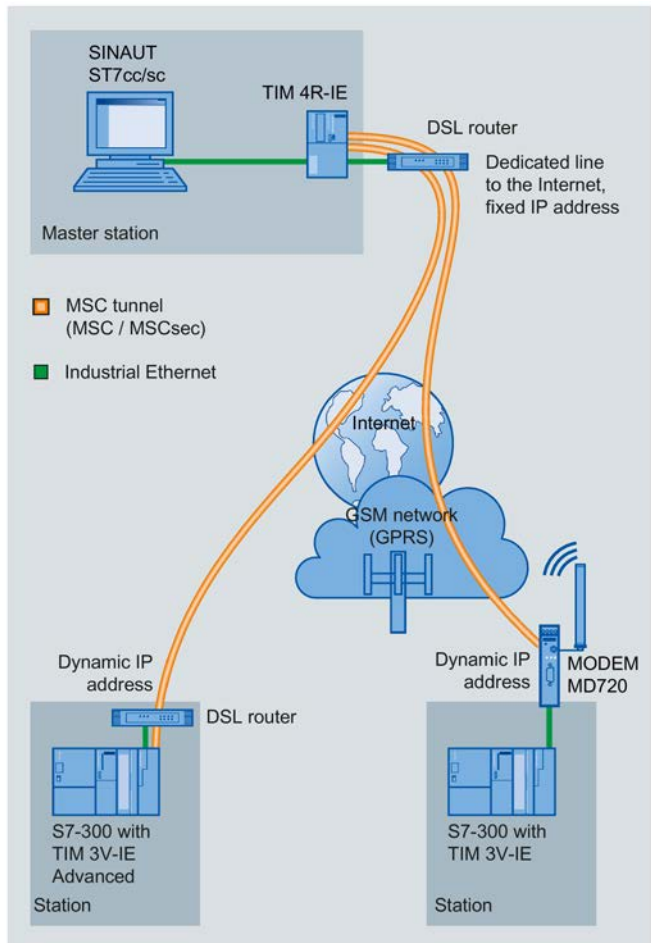

Figure 3-5 IP-based communication (GPRS/DSL) with MSC protocol via MD720 modem

IP-based communication via GPRS with higher security

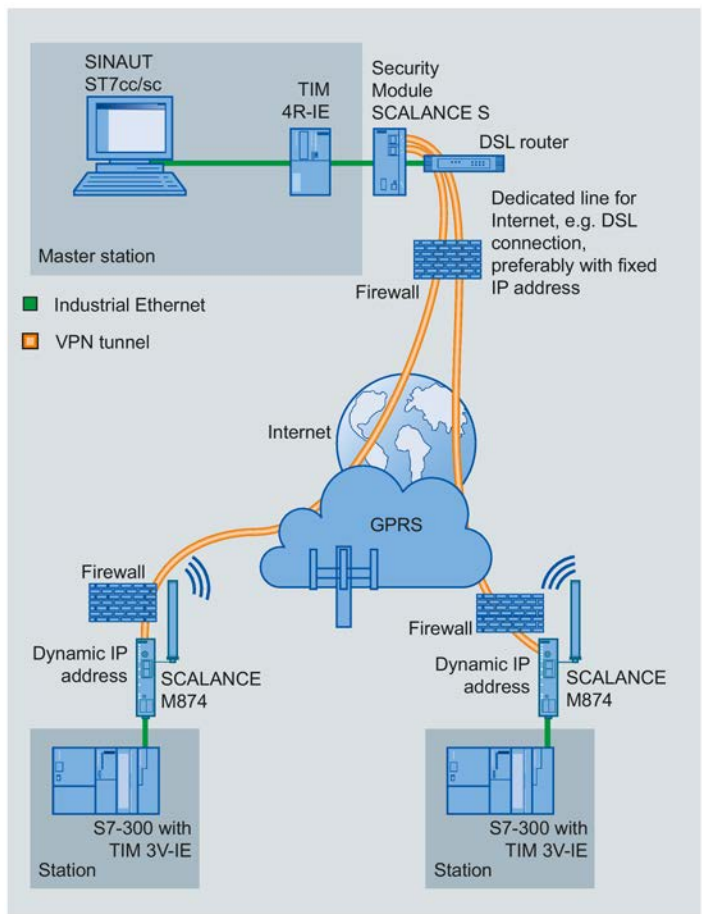
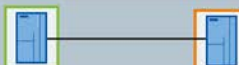

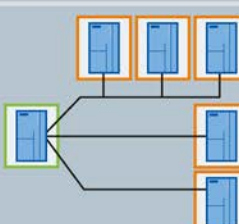
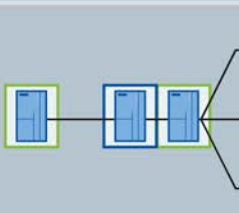
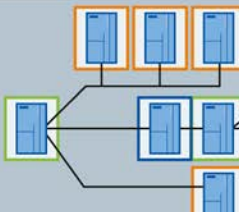
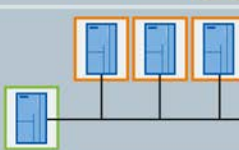





Figure 3-6 GPRS with higher security via SCALANCE M874 router

3.2.2 Configurations with classic WAN

Dedicated line configurations

Dedicated line configurations	Explanations
	Network type: Point-to-point Protocol: SINAUT ST7 and ST1 Operating mode: Polling
	Network type: Star Protocol: SINAUT ST7 and ST1 Operating mode: Polling
	Network type: Line Protocol: SINAUT ST7 and ST1 Operating mode: Polling
	Combination of - Point-to-point - Star - Line Protocol: SINAUT ST7 and ST1 Operating mode: Polling
	Combination of - Point-to-point - Nodes - Star Protocol: SINAUT ST7 and ST1 Operating mode: Polling
	Combination of - Point-to-point - Nodes - Star - Line Protocol: SINAUT ST7 and ST1 Operating mode: Polling
	Network type: Line with two master stations *) Protocol: SINAUT ST7 Operating mode: Multi-master polling with time slots

 Master station
 Station
 Node station

*) More than two master stations is possible

Figure 3-7 Dedicated line configurations

3.2 Configurations

Radio network configuration

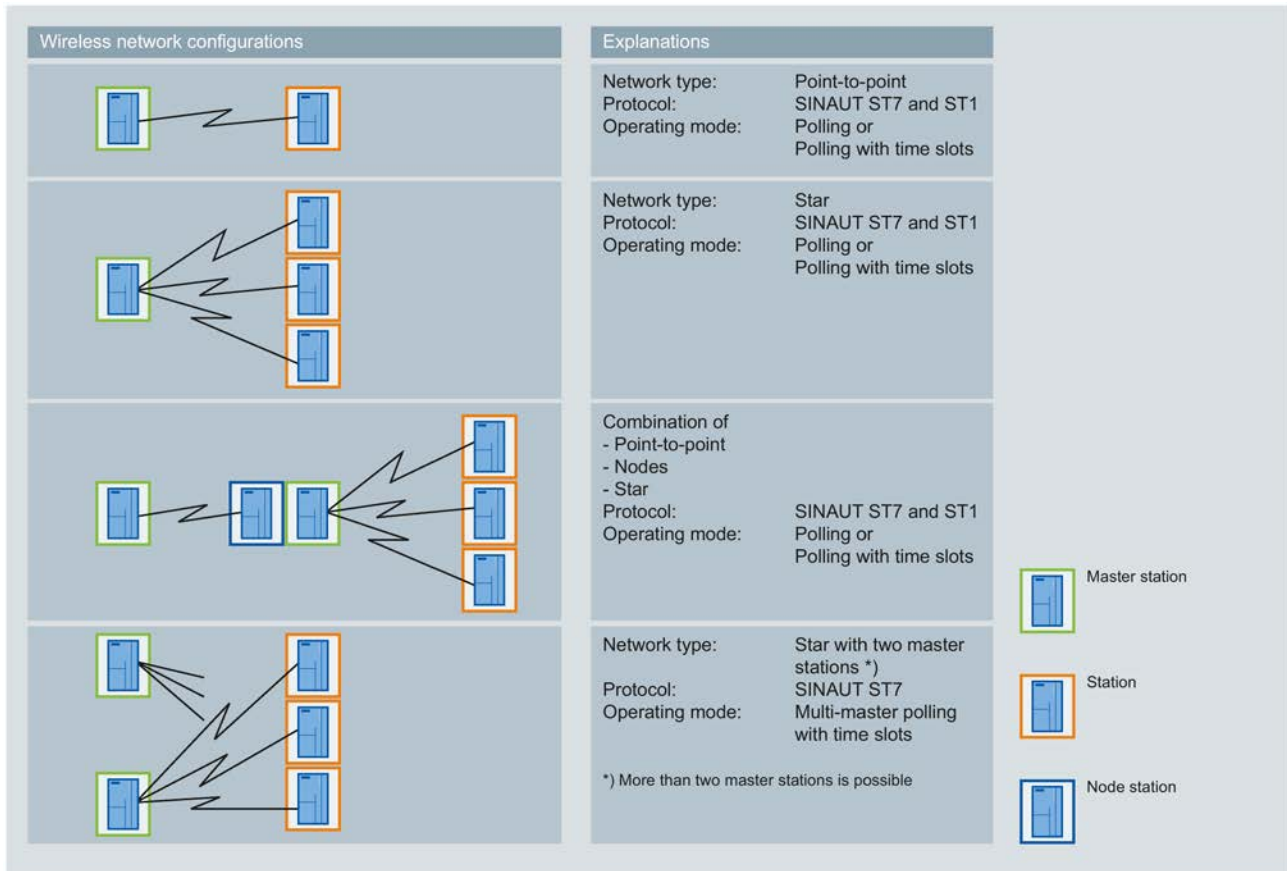

Figure 3-8 Radio network configurations

Dial-up network configuration

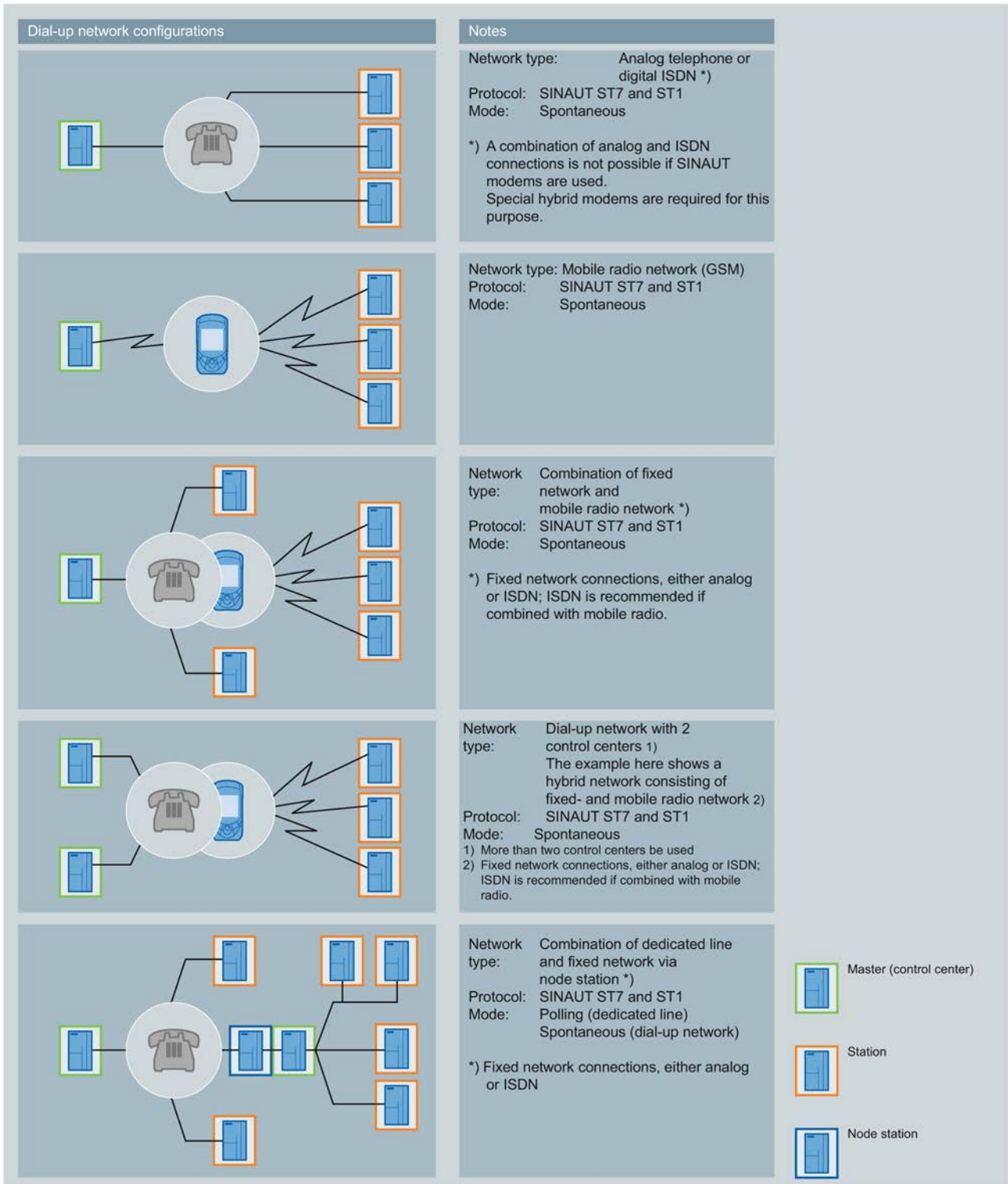
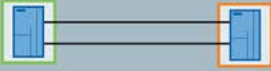
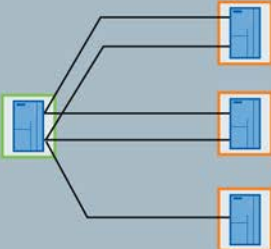
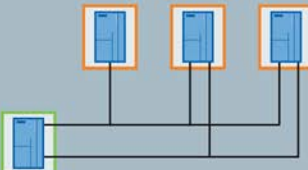

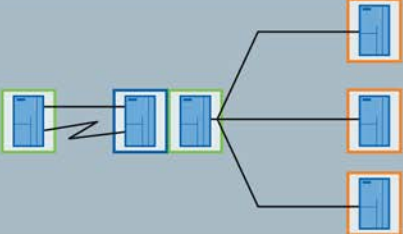
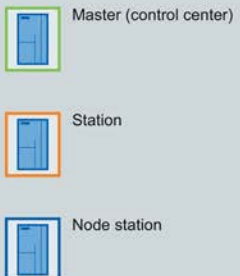

Figure 3-9 Dial-up network configurations

3.2 Configurations

Examples of redundant configurations

Redundant network configurations (examples)	Notes
	<p>Network type: Redundant point-to-point connection via two dedicated lines</p> <p>Protocol: SINAUT ST7 and ST1</p> <p>Mode: Polling</p>
	<p>Network type: Redundant star network via 2 dedicated lines each, mixed with non-redundantly connected stations</p> <p>Protocol: SINAUT ST7 and ST1</p> <p>Mode: Polling</p>
	<p>Network type: Redundant line network via 2 dedicated lines each, mixed with non-redundantly connected stations</p> <p>Protocol: SINAUT ST7 and ST1</p> <p>Mode: Polling</p>
	<p>Network type: Redundant point-to-point connection via dedicated line and dial-up network</p> <p>Protocol: SINAUT ST7 and ST1</p> <p>Mode: Polling (dedicated line) Spontaneous (dial-up network)</p>
	<p>Network type: Redundant Point-to-Point connection via dedicated line and radio between control center and node station; subordinate stations connected via a non-redundant star network</p> <p>Protocol: SINAUT ST7 and ST1</p> <p>Mode: Polling or polling with time slot procedure (wireless)</p>



Master (control center)

Station

Node station

Figure 3-10 Redundant configurations

For further options for setting up redundant transmission paths, refer to section Installing the TIM 4R-IE in an S7-300 (Page 70).

3.3 Installation guidelines and compatible CPUs

3.3.1 Installing the TIM 3V-IE variants in an S7-300

Introduction

The TIM 3V-IE variants can be used in an S7-300 as communications processors (CP). In principle, all S7-300 standard and compact CPUs can be combined with these TIMs. There are, however, constraints that must be taken into account relating to the way in which data exchange between the TIM and the CPU in the rack is handled (the SINAUT program). For the TIM 3V-IE variants, there are two options:

- TD7onTIM

This SINAUT TD7 program runs on the TIM.

All standard and compact CPUs can be used without restrictions.

- TD7onCPU

This SINAUT TD7 program runs on the CPU and is created for the CPU with blocks from the SINAUT TD7 library.

In this case, only CPUs with a work memory adequate to accommodate the SINAUT program can be used. The size of the program depends on the amount of data to be transmitted. At least 20 KB are required. TD7onCPU can be used for several standard CPU types if the following software packages are used:

- "SINAUT TD7 library for the CPU" as of V2.2
- "TIM firmware" as of V1.2

The following CPU lists also include older CPU types that can no longer be ordered as new devices but that nevertheless may still be in use in the field.

Standard CPU type	As of article number
CPUs with partyline *	
CPU 312	6ES7 312-1AD10-0AB0 6ES7 312-1AE13-0AB0 6ES7 312-1AE14-0AB0
CPU 312 IFM	6ES7 312-5AC00-0AB0 6ES7 312-5AC02-0AB0
CPU 313	6ES7 313-1AD00-0AB0 6ES7 313-1AD01-0AB0 6ES7 313-1AD02-0AB0 6ES7 313-1AD03-0AB0
CPU 314	6ES7 314-1AE02-0AB0 6ES7 314-1AE03-0AB0 6ES7 314-1AE04-0AB0 6ES7 314-1AF10-0AB0 6ES7 314-1AF11-0AB0 6ES7 314-1AG13-0AB0 6ES7 314-1AG14-0AB0

3.3 Installation guidelines and compatible CPUs

Standard CPU type	As of article number
CPU 314 IFM	6ES7 314-5AE02-0AB0 6ES7 314-5AE03-0AB0 6ES7 314-5AE10-0AB0
CPU 315	6ES7 315-1AF01-0AB0 6ES7 315-1AF02-0AB0 6ES7 315-1AF03-0AB0
CPU 315-2 DP	6ES7 315-2AF01-0AB0 6ES7 315-2AF02-0AB0 6ES7 315-2AF03-0AB0 6ES7 315-2AG10-0AB0 6ES7 315-2AH14-0AB0
CPUs without partyline *	
CPU 315-2 PN/DP	6ES7 315-2EG10-0AB0 6ES7 315-2EH13-0AB0 6ES7 315-2EH14-0AB0
CPU 315T-2 DP	6ES7 315-6TG10-0AB0 6ES7 315-6TH13-0AB0
CPU 315T-3 PN/DP	6ES7 315-7TH10-0AB0
CPU 315F-2 DP	6ES7 315-6FF00-0AB0 6ES7 315-6FF01-0AB0 6ES7 315-6FF04-0AB0
CPU 315F-2 PN/DP	6ES7 315-2FH10-0AB0 6ES7 315-2FH13-0AB0 6ES7 315-2FJ14-0AB0
CPU 316	6ES7 316-1AG00-0AB0
CPU 316-2 DP	6ES7 316-2AG00-0AB0
CPU 317-2 DP	6ES7 317-2AJ10-0AB0 6ES7 317-2AK14-0AB0
CPU 317-2 PN/DP	6ES7 317-2EJ10-0AB0 6ES7 317-2EK13-0AB0 6ES7 317-2EK14-0AB0
CPU 317T-2 DP	6ES7 317-6TJ10-0AB0 6ES7 317-6TK13-0AB0
CPU 317T-3 PN/DP	6ES7 317-7TK10-0AB0
CPU 317TF-2 DP	6ES7 317-6TF14-0AB0
CPU 317TF-3 PN/DP	6ES7 317-7UL10-0AB0
CPU 317F-2 DP	6ES7 317-6FF00-0AB0 6ES7 317-6FF03-0AB0 6ES7 317-6FF04-0AB0
CPU 317F-2 PN/DP	6ES7 317-2FJ10-0AB0 6ES7 317-2FK13-0AB0 6ES7 317-2FK14-0AB0
CPU 318-2	6ES7 318-2AJ00-0AB0
CPU 319-3 PN/DP	6ES7 318-3EL00-0AB0 6ES7 318-3EL01-0AB0
CPU 319F-3 PN/DP	6ES7 318-3FL00-0AB0 6ES7 318-3FL01-0AB0

* For partyline, see Glossary (Page 133).

Compact CPU *	Article number
CPU 312C	6ES7 312-5BD00-0AB0 6ES7 312-5BD01-0AB0 6ES7 312-5BE03-0AB0 6ES7 312-5BF04-0AB0
CPU 313C	6ES7 313-5BE00-0AB0 6ES7 313-5BE01-0AB0 6ES7 313-5BF03-0AB0 6ES7 313-5BG04-0AB0
CPU 313C-2 PtP	6ES7 313-6BE00-0AB0 6ES7 313-6BE01-0AB0 6ES7 313-6BF02-0AB0 6ES7 313-6BF03-0AB0 6ES7 313-6BG04-0AB0
CPU 313C-2 DP	6ES7 313-6CE00-0AB0 6ES7 313-6CE01-0AB0 6ES7 313-6CF03-0AB0 6ES7 313-6CG04-0AB0
CPU 314C-2 PtP	6ES7 314-6BF00-0AB0 6ES7 314-6BF01-0AB0 6ES7 314-6BF02-0AB0 6ES7 314-6BG03-0AB0 6ES7 314-6BH04-0AB0
CPU 314C-2 DP	6ES7 314-6CF00-0AB0 6ES7 314-6CF01-0AB0 6ES7 314-6CF02-0AB0 6ES7 314-6CG03-0AB0 6ES7 314-6CH04-0AB0
CPU 314C-2 PN/DP	6ES7 314-6EH04-0AB0 6ES7 314-6EH14-0AB0

* The Compact CPUs are CPUs with a partyline.

For partyline, see Glossary (Page 133).

Instead of an S7-300 standard or compact CPU, one of the following C7 control systems may also be used.

C7 complete unit *	Article number
C7-613	6ES7 613-1CA00-0AE3 6ES7 613-1CA01-0AE3 6ES7 613-1CA02-0AE3
C7-621	6ES7 621-1AD02-0AE3
C7-623/P	6ES7 623-1DE00-0AE3
C7-626/P	6ES7 626-1DG02-0AB3 6ES7 626-1DG04-0AE3
C7-626/P DP	6ES7 626-2DG02-0AB3 6ES7 626-2DG03-0AE3 6ES7 626-2DG04-0AE3
C7-633/P	6ES7 633-1DF00-0AB3 6ES7 633-1DF02-0AE3

3.3 Installation guidelines and compatible CPUs

C7 complete unit *	Article number
C7-633 DP	6ES7 633-2BF00-0AB3 6ES7 633-2BF01-0AE3 6ES7 633-2BF02-0AE3
C7-634/P	6ES7 634-1DF00-0AB3 6ES7 634-1DF02-0AE3
C7-634 DP	6ES7 634-2BF00-0AB3 6ES7 634-2BF01-0AE3 6ES7 634-2BF02-0AE3
C7-635 Key	6ES7 635-2EC00-0AB3 6ES7 635-2EC00-0AE3 6ES7 635-2EC01-0AE3 6ES7 635-2EC02-0AE3
C7-635 Touch	6ES7 635-2EB00-0AB3 6ES7 635-2EB00-0AE3 6ES7 635-2EB01-0AE3 6ES7 635-2EB02-0AE3
C7-636 Key	6ES7 636-2EC00-0AB3 6ES7 636-2EC00-0AE3
C7-636 Touch	6ES7 636-2EB00-0AB3 6ES7 636-2EB00-0AE3
SIPLUS C7-613	6ES7 613-1CA02-4AE3
SIPLUS C7-635 Key	6ES7 635-2EC02-4AE3

* The C7 complete units have a CPU with a partyline.

For partyline, see Glossary (Page 133).

Installation in a rack

With standard and compact CPU modules, the TIM can be inserted into any of the racks 0 to 3 but only in expansion racks 1 to 3 if these racks are connected to the CPU over the IM 360/IM 361 interface modules.

With the C7 control systems, the TIM can be inserted in any of the expansion racks 1 to 3. These are connected to the C7 device over IM 360/IM 361 interface modules (the IM 360 is already integrated in the C7 device). With the C7-635 and C7-636 devices, this is also possible without the IM 361 if no more than four modules including the TIM are connected externally.

For all S7-300 racks the following applies: All slots designed for SM, FM or CP can also be used for the TIM.

A bus module connector ships with every TIM. The TIM is connected to the module to its left by the bus module connector.

If a SINAUT modem of the type MD2, MD3 or MD4 is used, this can be installed on a separate S7-300 rail or on a 35 mm DIN rail (an adapter is available). To save space, it can also be installed in a free slot of racks 0 to 3. This modem is connected over the RS-232 interface of the TIM using a standard connecting cable, type 6NH7701-xxx.

Note

Since the SINAUT modems MD2, MD3 and MD4 do not have an S7-300 backplane bus, an S7-300 SM, FM or CP module that communicates with the CPU over this backplane bus must not be inserted to the right of the modem!

Note

In all of the sample configurations of the S7-300, it is assumed that a 24 V power supply is available for the CPU, the TIMs and the other modules.

Note

Direct connection of a TIM 3V-IE variant to the PROFINET interface of an S7-300-CPU is not possible!

S7-300 with access to a classic WAN

To implement classic WAN access for an S7-300, you can use either a TIM 3V-IE or a TIM 3V-IE Advanced. The following figure shows such a configuration.

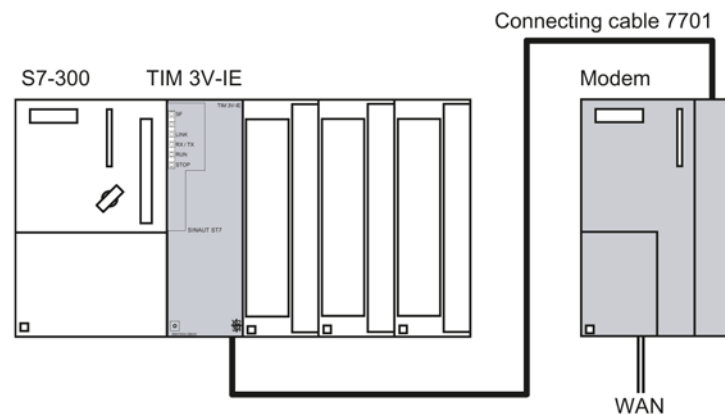

Figure 3-11 SIMATIC S7-300 with TIM 3V-IE with 1 connection to classic WAN over an external modem.

Other modems with an RS-232 interface can also be used, for example wireless devices or the MODEM MD720.

S7-300 with access to IP-based WAN

To implement IP-based WAN access for an S7-300, you can use either a TIM 3V-IE or a TIM 3V-IE Advanced.

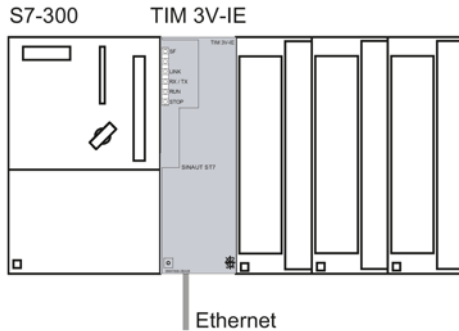

Figure 3-12 SIMATIC S7-300 with TIM 3V-IE with a connection to IP-based WAN

A module is required on the Ethernet interface (RJ-45) of the TIM to link the TIM to an IP-based WAN. The following are, for example, possible:

- SCALANCE X switches for twisted-pair or FO cable
- SCALANCE W wireless devices for data transmission over IWLAN
- Other wireless devices optimized for Ethernet
- GSM router SCALANCE M874 / MD741-1 for data transfer via mobile phone with GPRS
- MODEM MD720 for simple Internet communication with an MSC tunnel (see Vvolume 2 of this manual)
- DSL router
- Backbone transmission systems such as OTN, PCM30

Two examples are illustrated below.

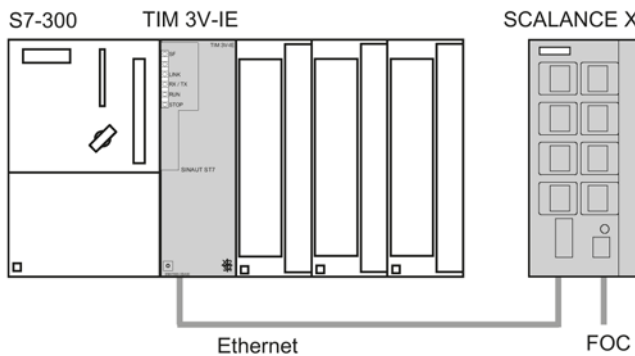

Figure 3-13 SIMATIC S7-300 with TIM 3V-IE connected to an FO cable over a SCALANCE X-200

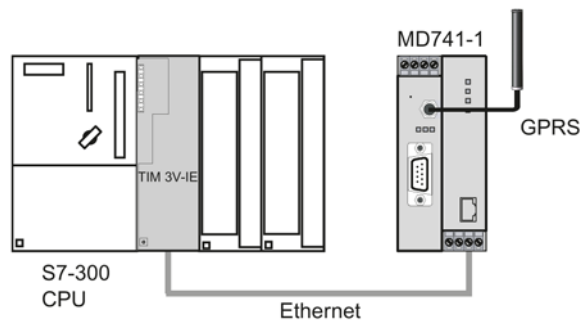

Figure 3-14 SIMATIC S7-300 with TIM 3V-IE, 1 GPRS access via MD741-1 router

S7-300 with two WAN attachments

To achieve two connections to a WAN for an S7-300, in other words, classic WAN access and IP-based access, a TIM 3V-IE Advanced must be used. A TIM 3V-IE is not suitable in this case, because only one of its two interfaces can be used. The following figure shows such a configuration.

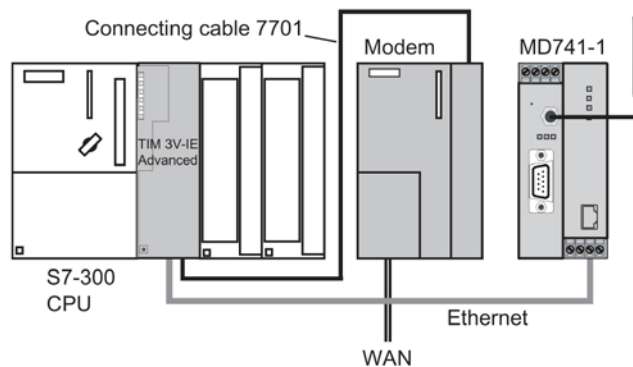

Figure 3-15 SIMATIC S7-300 with TIM 3V-IE Advanced with 2 connections to a WAN

Instead of the MDx SINAUT modem, other modems with an RS-232 interface can also be used, for example wireless devices or the MD720.

S7-300 with maximum configuration

A maximum of one TIM 3V-IE can be inserted in an S7-300. Only one of the two interfaces (RS-232, RJ45) can then be used for SINAUT data transmission.

If a TIM 3V-IE Advanced is used, the maximum number that can be inserted in an S7-300 depends on the resources provided by the CPU. Two connection resources per TIM are required on the CPU.

Apart from the connection resources, the available work memory on the CPU must also be taken into consideration. The more TIMs installed and the more stations connected and the more objects processed per station, the greater the memory requirements of the telecontrol-specific user program on the CPU. This TD7 program runs either on the CPU (TD7onCPU) or on the TIM (TD7onTIM).

ST7cc / ST7sc with the TIM 3V-IE Advanced

A TIM 3V-IE Advanced can be used as a master TIM for the PC of the ST7cc or ST7sc control center. In this case, the TIM 3V-IE Advanced requires an S7-300 CPU because it cannot work without a CPU.

In the two cases illustrated below, the maximum number of TIMs in the rack is not limited by the connection resources of the CPU because they are not required. You should not insert more than 8 TIMs. Less TIMs per CPU are preferable to achieve better availability. The greatest availability is achieved when there is only one (1) TIM in the rack connected to the CPU over the backplane bus.

There are two ways of connecting the CPU/TIM module combination to the PC as illustrated by the following two configurations.

Connection to ST7cc / ST7sc over MPI

The following figure shows a configuration in which the TIM is connected to the PC over the MPI interface of its CPU. This requires a CPU with partyline to be used in the S7-300 rack. Only then can the TIM be addressed as a node under its own MPI address on the MPI bus. This allows the PC and TIM to exchange data directly. No SINAUT software is necessary on the CPU.

With this configuration, the TIM 3V-IE Advanced provides the control center with two connections to a WAN:

- Over the RS-232 interface to a classic WAN
- Over the RJ-45 interface to an IP-based WAN

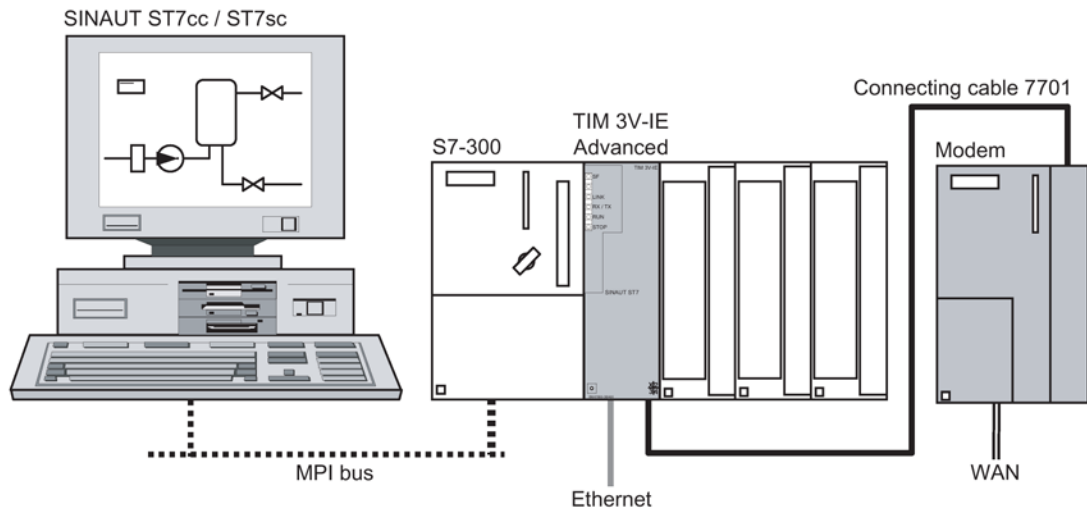

Figure 3-16 SINAUT ST7cc / ST7sc control center with a TIM 3V-IE Advanced connected over MPI, a classic connection to WAN and an IP-based connection to WAN

With this configuration, further TIM 3V-IE Advanced modules could be inserted in the S7-300 rack and all connected to the PC over the MPI port of the CPU. Each TIM provides the PC with two further connections to the WAN. In this case, the maximum number of TIM modules is not restricted by the connection resources of the CPU because they are not required. The

maximum number of TIM modules is restricted by the number of connection resources of the CP in the control center PC.

Connection to ST7cc / ST7sc over Ethernet

The following figure shows a configuration in which the TIM is connected to the PC over its Ethernet interface. As of ST7cc V2.5 or ST7sc V1.1, the TIM can exchange data directly with ST7cc/ST7sc over its Ethernet interface.

There are no special requirements of the CPU for this configuration. No SINAUT software is necessary on the CPU for communication between the TIM and PC.

Since the Ethernet interface is occupied by the local communication with the PC, the TIM 3V IE Advanced of the only provides the control center with one connection to a WAN in this configuration.

- Over the RS-232 interface to a classic WAN

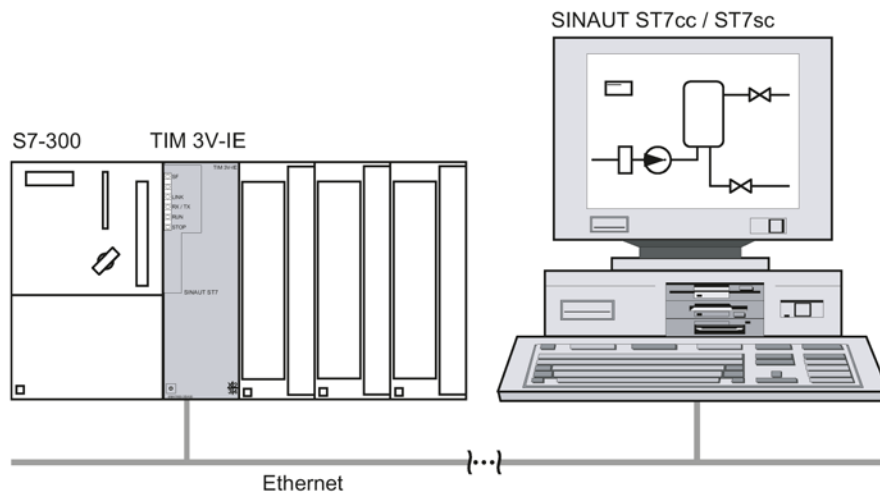

Figure 3-17 SINAUT ST7cc / ST7sc control center system with a connection to a TIM 3V-IE Advanced over Ethernet and classic WAN access.

Even with this configuration, further TIM 3V-IE Advanced modules can be inserted in the S7-300 rack. Each TIM can be connected to the PC over its Ethernet interface and provides the PC with one connection to a WAN.

The other TIMs can also transfer their data to the first TIM over the backplane bus and use the Ethernet interface of this TIM as a common access to the PC. In this case, each further TIM provides the PC with two connections to the WAN. In this case, the maximum number of TIM modules is not restricted by the connection resources of the CPU because they are not required. The maximum number of TIM modules is restricted by the number of connection resources of the CP in the control center PC.

3.3.2 Installing the TIM 4R-IE in an S7-300

Introduction

The TIM 4R-IE can be used in an S7-300 as a communications processor (CP). All S7-300 standard and compact CPUs can be combined with the TIM 4R-IE. There are, however, constraints that must be taken into account relating to the way in which data exchange between the TIM and the CPU in the rack is handled (the SINAUT program). For the TIM 4R-IE, there are two options:

- TD7onTIM
This SINAUT TD7 program runs on the TIM.
All standard and compact CPUs can be used without restriction.
- TD7onCPU
This SINAUT TD7 program runs on the CPU and is created for the CPU with the blocks from the SINAUT TD7 library.
In this case, only CPUs with a work memory adequate to accommodate the SINAUT program can be used. The size of the program depends on the amount of data to be transmitted. At least 20 Kbytes are required.

TD7onCPU can be used for several CPU types if the following software packages are used:

- "SINAUT TD7 library for the CPU" as of V2.2
- "TIM firmware" as of V1.0

The following CPU lists also include older CPU types that can no longer be ordered as new devices but that nevertheless may still be in use in the field.

Standard CPU type	As of article number
CPUs with partyline *	
CPU 312	6ES7 312-1AD10-0AB0 6ES7 312-1AE13-0AB0 6ES7 312-1AE14-0AB0
CPU 312 IFM	6ES7 312-5AC00-0AB0 6ES7 312-5AC02-0AB0
CPU 313	6ES7 313-1AD00-0AB0 6ES7 313-1AD01-0AB0 6ES7 313-1AD02-0AB0 6ES7 313-1AD03-0AB0
CPU 314	6ES7 314-1AE02-0AB0 6ES7 314-1AE03-0AB0 6ES7 314-1AE04-0AB0 6ES7 314-1AF10-0AB0 6ES7 314-1AF11-0AB0 6ES7 314-1AG13-0AB0 6ES7 314-1AG14-0AB0
CPU 314 IFM	6ES7 314-5AE02-0AB0 6ES7 314-5AE03-0AB0 6ES7 314-5AE10-0AB0

Standard CPU type	As of article number
CPU 315	6ES7 315-1AF01-0AB0 6ES7 315-1AF02-0AB0 6ES7 315-1AF03-0AB0
CPU 315-2 DP	6ES7 315-2AF01-0AB0 6ES7 315-2AF02-0AB0 6ES7 315-2AF03-0AB0 6ES7 315-2AG10-0AB0 6ES7 315-2AH14-0AB0
CPUs without partyline *	
CPU 315-2 PN/DP	6ES7 315-2EG10-0AB0 6ES7 315-2EH13-0AB0 6ES7 315-2EH14-0AB0
CPU 315T-2 DP	6ES7 315-6TG10-0AB0 6ES7 315-6TH13-0AB0
CPU 315T-3 PN/DP	6ES7 315-7TH10-0AB0
CPU 315F-2 DP	6ES7 315-6FF00-0AB0 6ES7 315-6FF01-0AB0 6ES7 315-6FF04-0AB0
CPU 315F-2 PN/DP	6ES7 315-2FH10-0AB0 6ES7 315-2FH13-0AB0 6ES7 315-2FJ14-0AB0
CPU 316	6ES7 316-1AG00-0AB0
CPU 316-2 DP	6ES7 316-2AG00-0AB0
CPU 317-2 DP	6ES7 317-2AJ10-0AB0 6ES7 317-2AK14-0AB0
CPU 317-2 PN/DP	6ES7 317-2EJ10-0AB0 6ES7 317-2EK13-0AB0 6ES7 317-2EK14-0AB0
CPU 317T-2 DP	6ES7 317-6TJ10-0AB0 6ES7 317-6TK13-0AB0
CPU 317T-3 PN/DP	6ES7 317-7TK10-0AB0
CPU 317TF-2 DP	6ES7 317-6TF14-0AB0
CPU 317TF-3 PN/DP	6ES7 317-7UL10-0AB0
CPU 317F-2 DP	6ES7 317-6FF00-0AB0 6ES7 317-6FF03-0AB0 6ES7 317-6FF04-0AB0
CPU 317F-2 PN/DP	6ES7 317-2FJ10-0AB0 6ES7 317-2FK13-0AB0 6ES7 317-2FK14-0AB0
CPU 318-2	6ES7 318-2AJ00-0AB0
CPU 319-3 PN/DP	6ES7 318-3EL00-0AB0 6ES7 318-3EL01-0AB0
CPU 319F-3 PN/DP	6ES7 318-3FL00-0AB0 6ES7 318-3FL01-0AB0

3.3 Installation guidelines and compatible CPUs

* For partyline, see Glossary (Page 133).

Compact CPU *	Article number
CPU 312C	6ES7 312-5BD00-0AB0 6ES7 312-5BD01-0AB0 6ES7 312-5BE03-0AB0 6ES7 312-5BF04-0AB0
CPU 313C	6ES7 313-5BE00-0AB0 6ES7 313-5BE01-0AB0 6ES7 313-5BF03-0AB0 6ES7 313-5BG04-0AB0
CPU 313C-2 PtP	6ES7 313-6BE00-0AB0 6ES7 313-6BE01-0AB0 6ES7 313-6BF02-0AB0 6ES7 313-6BF03-0AB0 6ES7 313-6BG04-0AB0
CPU 313C-2 DP	6ES7 313-6CE00-0AB0 6ES7 313-6CE01-0AB0 6ES7 313-6CF03-0AB0 6ES7 313-6CG04-0AB0
CPU 314C-2 PtP	6ES7 314-6BF00-0AB0 6ES7 314-6BF01-0AB0 6ES7 314-6BF02-0AB0 6ES7 314-6BG03-0AB0 6ES7 314-6BH04-0AB0
CPU 314C-2 DP	6ES7 314-6CF00-0AB0 6ES7 314-6CF01-0AB0 6ES7 314-6CF02-0AB0 6ES7 314-6CG03-0AB0 6ES7 314-6CH04-0AB0
CPU 314C-2 PN/DP	6ES7 314-6EH04-0AB0 6ES7 314-6EH14-0AB0

* The Compact CPUs are CPUs with a partyline.

For partyline, see Glossary (Page 133).

Instead of an S7-300 standard or compact CPU, one of the following C7 control systems may also be used.

C7 complete unit *	Article number
C7-613	6ES7 613-1CA00-0AE3 6ES7 613-1CA01-0AE3 6ES7 613-1CA02-0AE3
C7-621	6ES7 621-1AD02-0AE3
C7-623/P	6ES7 623-1DE00-0AE3
C7-626/P	6ES7 626-1DG02-0AB3 6ES7 626-1DG04-0AE3
C7-626/P DP	6ES7 626-2DG02-0AB3 6ES7 626-2DG03-0AE3 6ES7 626-2DG04-0AE3
C7-633/P	6ES7 633-1DF00-0AB3 6ES7 633-1DF02-0AE3

C7 complete unit *	Article number
C7-633 DP	6ES7 633-2BF00-0AB3 6ES7 633-2BF01-0AE3 6ES7 633-2BF02-0AE3
C7-634/P	6ES7 634-1DF00-0AB3 6ES7 634-1DF02-0AE3
C7-634 DP	6ES7 634-2BF00-0AB3 6ES7 634-2BF01-0AE3 6ES7 634-2BF02-0AE3
C7-635 Key	6ES7 635-2EC00-0AB3 6ES7 635-2EC00-0AE3 6ES7 635-2EC01-0AE3 6ES7 635-2EC02-0AE3
C7-635 Touch	6ES7 635-2EB00-0AB3 6ES7 635-2EB00-0AE3 6ES7 635-2EB01-0AE3 6ES7 635-2EB02-0AE3
C7-636 Key	6ES7 636-2EC00-0AB3 6ES7 636-2EC00-0AE3
C7-636 Touch	6ES7 636-2EB00-0AB3 6ES7 636-2EB00-0AE3
SIPLUS C7-613	6ES7 613-1CA02-4AE3
SIPLUS C7-635 Key	6ES7 635-2EC02-4AE3

* The C7 complete units have a CPU with a partyline.

For partyline, see Glossary (Page 133).

Installation in a rack

With standard and compact CPU modules, the TIM can be inserted into any of the racks 0 to 3 but only in expansion racks 1 to 3 if these racks are connected to the CPU over the IM 360/IM 361 interface modules.

With the C7 control systems, the TIM can be inserted in any of the expansion racks 1 to 3. These are connected to the C7 device over IM 360/IM 361 interface modules (the IM 360 is already integrated in the C7 device). With the C7-635 and C7-636 devices, this is also possible without the IM 361 if no more than four modules including the TIM are connected externally.

For all S7-300 racks the following applies: All slots designed for SM, FM or CP can also be used for the TIM.

A bus module connector ships with every TIM. The TIM is connected to the module to its left by the bus module connector.

If a SINAUT modem of the type MD2, MD3 or MD4 is used, this can be installed on a separate S7-300 rail or on a 35 mm DIN rail (an adapter is available). To save space, it can also be installed in a free slot of racks 0 to 3. This modem is connected over the RS-232 interface of the TIM using a standard connecting cable, type 6NH7701-xxx.

Note

Since the SINAUT modems MD2, MD3 and MD4 do not have an S7-300 backplane bus, an S7-300 SM, FM or CP module that communicates with the CPU over this backplane bus must not be inserted to the right of the modem!

Note

In all of the sample configurations of the S7-300, it is assumed that a 24 V power supply is available for the CPU, the TIMs and the other modules.

The maximum number of TIM modules that can be inserted in an S7-300 station depends on the connection resources made available by the CPU.

S7-300 with one TIM 4R-IE

With an S7-300 and one TIM 4R-IE, it is possible to set up an extremely efficient node station. The following figure shows an example in which the master station is connected over one of the two Ethernet interfaces of the TIM. The connections to the subsidiary stations are established over the other three interfaces: here, over two classic WANs using suitable MDx SINAUT modems and over an IP-based WAN, in this case an FO cable connected via a SCALANCE X switch.

In these configurations, the master station and stations can exchange data among themselves over the TIM 4R-IE as well as with the CPU of the node station. The TIM 4R-IE also supports direct communication between stations in the three underlying networks, in other words both within a network and from one network to another.

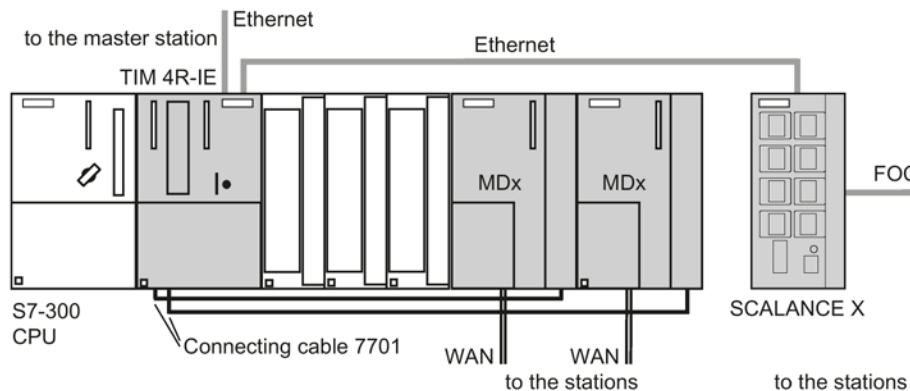

Figure 3-18 SIMATIC S7-300 with TIM 4R-IE, 2 connections to WAN, 2 connections to Ethernet, one Ethernet interface connected over SCALANCE X-200 by FO cable

Instead of the MDx SINAUT modem, other modems with an RS-232 or RS-485 interface can also be used, for example wireless devices or the MD720.

The following figure shows a different node station variant in which the TIM 4R-IE has a redundant connection both to the master station and to the subsidiary stations. A variant of this configuration would be to have a redundant connection only to the master station and to

have single transmission paths to the stations. Which two interfaces are redundant can be freely selected by the user.

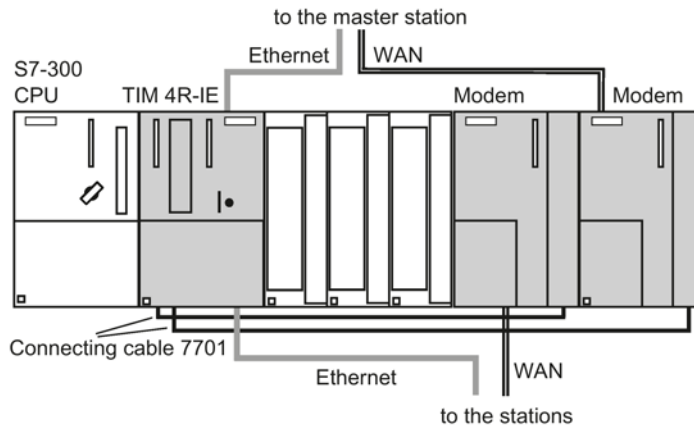

Figure 3-19 SIMATIC S7-300 with TIM 4R-IE,
1 connection to WAN and 1 connection to Ethernet as redundant routes to the stations
and to the master station

Standalone TIM 4R-IE as master station or node station

The following figure shows the use of the TIM 4R-IE in a standalone configuration; in other words, without an S7-300 CPU. This configuration is found typically in a master station. It could, however, also be used in a node station if its sole purpose is to interconnect the various networks over the TIM and no local control or data acquisition is required.

In this configuration, you can see in detail how a station can be connected redundantly. The example assumes that the main path is implemented as a dedicated line. The alternative path is via the GPRS mobile phone service and the Internet.

The redundantly connected station has an Ethernet TIM (in this case a TIM 3V-IE Advanced). To connect to the alternative path, the Ethernet interface is connected to the GSM router SCALANCE M874 / MD741-1. The data is transferred via GPRS and the Internet to the TIM in the master/node station using the substitute value. There, a fixed connection to the Internet is required, for example over a DSL router. To provide security on the path over GPRS/Internet, a SCALANCE S security module (for example S612) is inserted between the TIM and DSL router in order to establish a VPN tunnel to the MD741-1. A SCALANCE M874 router can be used instead of DSL router and SCALANCE S612 A.

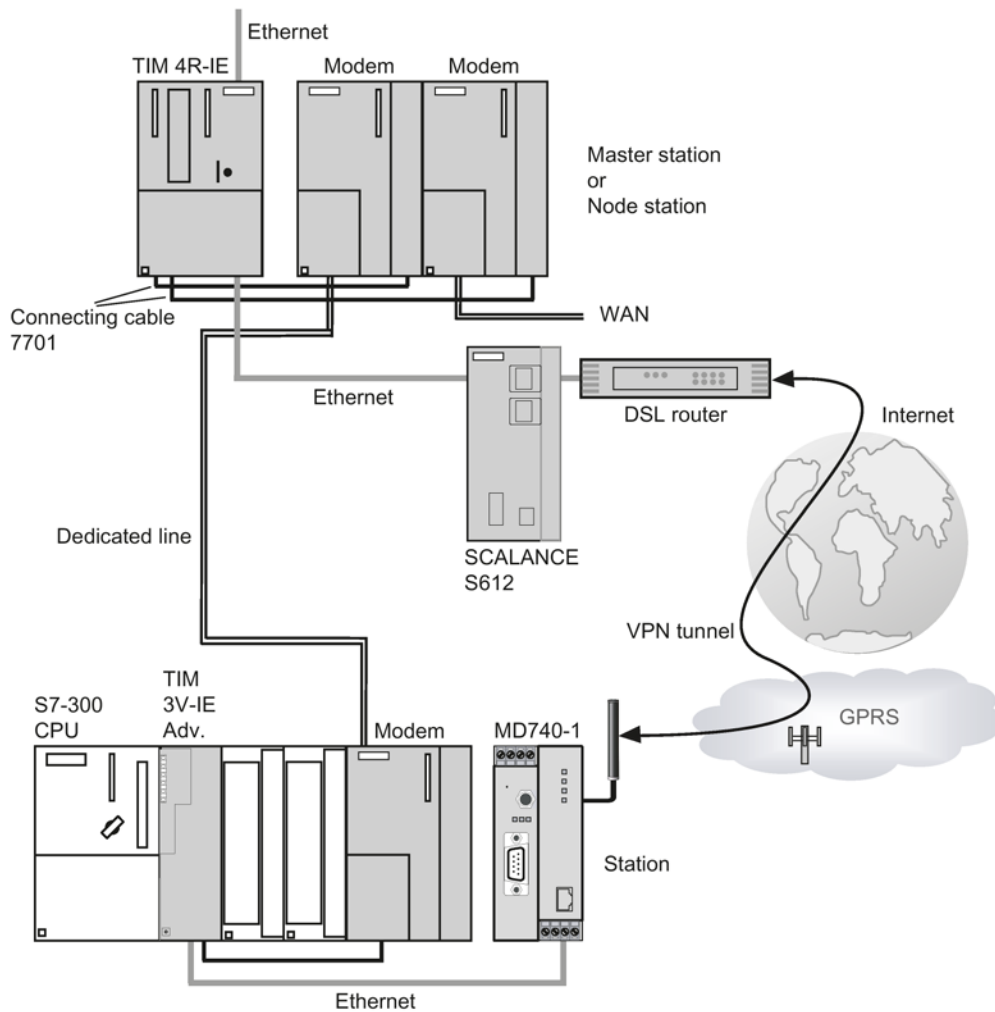

Figure 3-20 TIM 4R-IE in a master station or node station, redundant connection to subsidiary station; one path as dedicated line, the second over GPRS and Internet

Direct communication over TIM 4R-IE and other TIM modules

As described above, with a TIM 4R-IE, direct communication is possible between all stations on all networks connected to the TIM. If there are other TIM modules on Ethernet or on the MPI bus in addition to the TIM 4R-IE, direct communication can also be extended to the networks of the other TIMs.

The first example shows the path of direct communication between stations connected to a standalone TIM 4R-IE and a TIM 3V-IE. The two TIMs are interconnected over Ethernet.

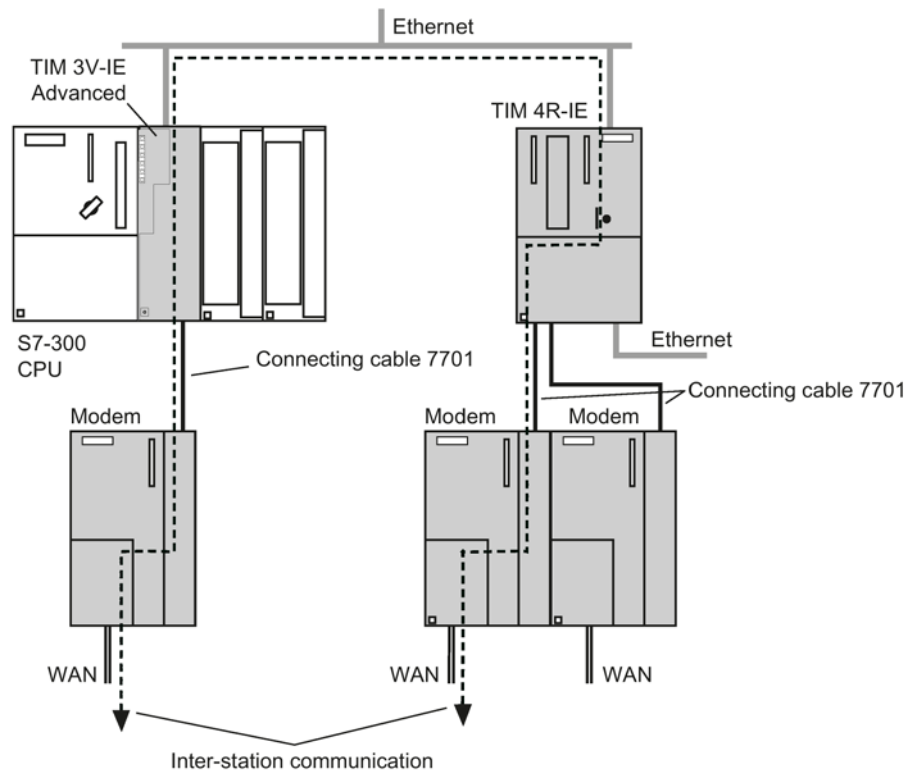

Figure 3-21 Direct communication over a standalone TIM 4R-IE and a TIM 3V-IE Advanced (direct communication paths are shown as dashed lines)

The second example shows the path of direct communication between stations connected to a standalone TIM 4 and a TIM 4R-IE. The two TIMs are interconnected over MPI. The TIM 4R-IE is installed in an S7-300 so that it can communicate with the standalone TIM 4 over the MPI interface of the CPU. Within the S7-300, the direct communication path is via the backplane bus.

3.3 Installation guidelines and compatible CPUs

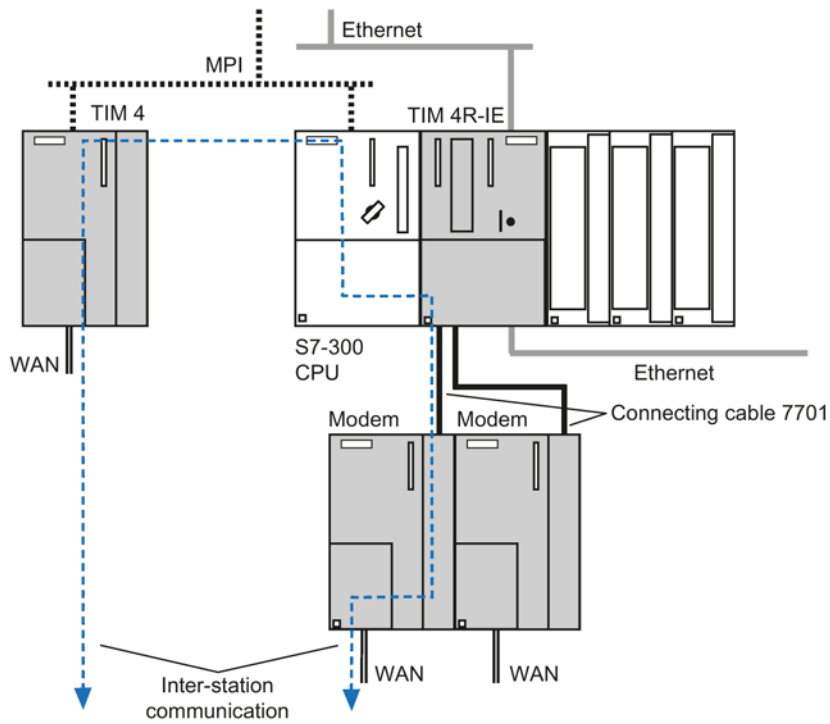

Figure 3-22 Direct communication over a TIM 4 (standalone), MPI and a TIM 4R-IE, installed in an S7-300; communication within the S7-300 over the backplane bus (direct communication paths are shown as dashed lines)

A further example shows the path of direct communication between stations connected to a TIM 4R-IE and a TIM 4 or TIM 3. The two TIMs are installed in an S7-300 and interconnected over the backplane bus. Within the S7-300, the direct communication path is via the backplane bus. In this example, this also applies to the data exchanged with the master station over the TIM 3/4 (see figure below).

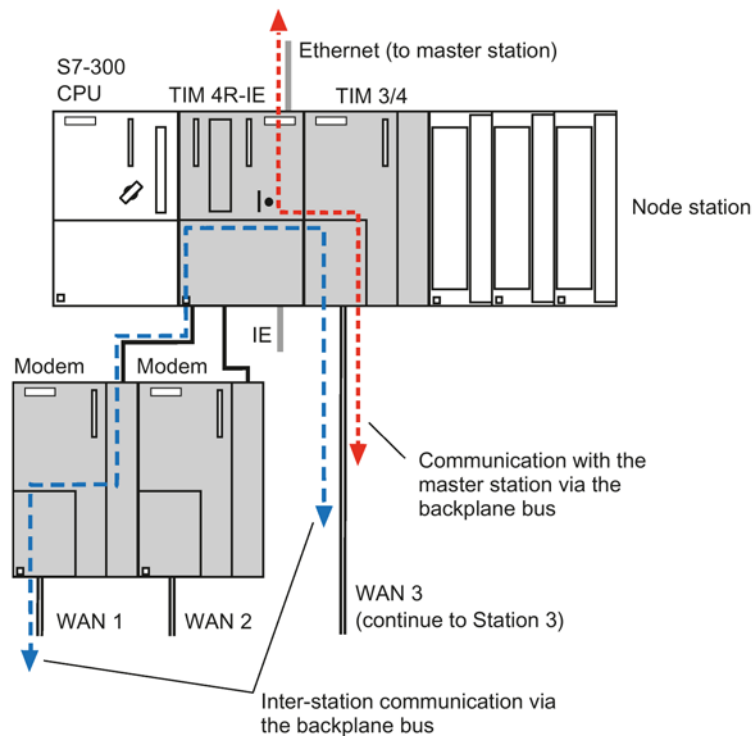

Figure 3-23 Direct communication over a TIM 4R-IE and a TIM 3 or TIM 4 in an S7-300 rack; communication within the S7-300 over the backplane bus (direct communication paths are shown as dashed lines)

In this example, the CPU of station 3 (not shown in figure) on WAN 3 communicates with the master station and one or more stations on WAN 1 over a TIM 3 or TIM 4 and the TIM 4R-IE.

Note

When selecting the CPU in the above node station configuration, the following applies:

If the stations connected to the TIM 3/4 (for example station 3) also need to exchange data with the CPU in the node station, you must use a CPU with a partyline, see table above.

If the TIM 3/4 does not need to communicate with the CPU in the node station, you can select any CPU.

3.3.3 Standalone TIM 4R-IE with an S7-400 or PC

Introduction

In standalone mode, in other words, without an S7-300-CPU, the TIM 4R-IE is ideally suited as a SINAUT communications processor for an S7-400 or for the PC of the ST7cc or ST7sc control center.

3.3 Installation guidelines and compatible CPUs

The following S7-400 CPUs can be connected via Ethernet.

CPU type	As of article number	Minimum product version / firm-ware version
CPU 412-1	6ES7 412-1XF00-0AB0 6ES7 412-1XF01-0AB0 6ES7 412-1XF02-0AB0 6ES7 412-1XF03-0AB0 6ES7 412-1XF04-0AB0 6ES7 412-1XJ05-0AB0 6ES7 412-1XJ07-0AB0	2 1 2 1 / V1.1.0 V4.0 V5.0 V7
CPU 412-2	6ES7 412-2XG00-0AB0 6ES7 412-2XG04-0AB0 6ES7 412-2XJ05-0AB0 6ES7 412-2XJ07-0AB0	1 / V1.1.0 V4.0 V5.0 V7.0
CPU 412-2 PN	6ES7 412-2EK06-0AB0 6ES7 412-2EK07-0AB0	1 V6.0
CPU 413-1	6ES7 413-1XG00-0AB0 6ES7 413-1XG01-0AB0 6ES7 413-1XG02-0AB0	2 1 1
CPU 413-2	6ES7 413-2XG00-0AB0 6ES7 413-2XG01-0AB0 6ES7 413-2XG02-0AB0	3 1 1
CPU 414-1	6ES7 414-1XG00-0AB0 6ES7 414-1XG01-0AB0 6ES7 414-1XG02-0AB0	2 1 2
CPU 414-2	6ES7 414-2XJ00-0AB0 6ES7 414-2XJ01-0AB0 6ES7 414-2XG00-0AB0 6ES7 414-2XG01-0AB0 6ES7 414-2XG02-0AB0 6ES7 414-2XG03-0AB0 6ES7 414-2XG04-0AB0 6ES7 414-2XK05-0AB0 6ES7 414-2XL07-0AB0	1 2 3 1 2 1 / V1.1.0 V4.0 V5.0 V7.0
CPU 414-3 ¹⁾	6ES7 414-3XJ00-0AB0 6ES7 414-3XJ04-0AB0 6ES7 414-3XM05-0AB0 6ES7 414-3XM07-0AB0	1 V4.0 V5.0 V7.0
CPU 414-3 PN/DP	6ES7 414-3EM06-0AB0 6ES7 414-3EM07-0AB0	V6.0 V7.0
CPU 414F-3 PN/DP	6ES7 414-3FM06-0AB0 6ES7 414-3FM07-0AB0	V6.0 V7.0
CPU 414-4H ¹⁾	6ES7 414-4HJ00-0AB0 6ES7 414-4HJ04-0AB0 6ES7 414-4HM14-0AB0 6ES7 414-4HR14-0AB0	V3.1.4 V4.0.10 V4.5.0 V4.5.0
CPU 414-5H ¹⁾	6ES7 414-4HM06-0AB0	V6.0
CPU 416-1	6ES7 416-1XJ00-0AB0 6ES7 416-1XJ01-0AB0 6ES7 416-1XJ02-0AB0	2 1 2

CPU type	As of article number	Minimum product version / firm-ware version
CPU 416-2	6ES7 416-2XL00-0AB0	1
	6ES7 416-2XL01-0AB0	1
	6ES7 416-2XK00-0AB0	1
	6ES7 416-2XK01-0AB0	1
	6ES7 416-2XK02-0AB0	1 / V1.1.0
	6ES7 416-2XK04-0AB0	V4.0
	6ES7 416-2XN05-0AB0	V5.0
	6ES7 416-2XP07-0AB0	V7.0
CPU 416F-2	6ES7 416-2FK02-0AB0	1
	6ES7 416-2FK04-0AB0	V4.0
	6ES7 416-2FN05-0AB0	V5.0
	6ES7 416-2FP07-0AB0	V7.0
CPU 416-3	6ES7 416-3XL00-0AB0	1
	6ES7 416-3XL04-0AB0	V4.0
	6ES7 416-3XR05-0AB0	V5.0
	6ES7 416-3XS07-0AB0	V7.0
CPU 416-3 PN/DP	6ES7 416-3ES06-0AB0	V6.0
	6ES7 416-3ES07-0AB0	V7.0
CPU 416F-3 PN/DP	6ES7 416-3FS06-0AB0	V6.0
	6ES7 416-3FS07-0AB0	V7.0
CPU 416F-5H PN/DP ¹⁾	6ES7 416-5HS06-0AB0	V6.0
CPU 417-4	6ES7 417-4XL00-0AB0	1
	6ES7 417-4XL04-0AB0	V4.0
	6ES7 417-4XT05-0AB0	V5.0
	6ES7 417-4XT07-0AB0	V7.0
CPU 417-4H ¹⁾	6ES7 417-4HL00-0AB0	1 / V2.1.0
	6ES7 417-4HL01-0AB0	1 / V2.1.0
	6ES7 417-4HL04-0AB0	V4.0.10
	6ES7 417-4HL07-0AB0	V4.5.0
CPU 417-5H PN/DP ¹⁾	6ES7 417-5HT06-0AB0	V6.0

¹⁾ Fault-tolerant SINAUT solutions with a H CPUs are not possible!

With the SINAUT ST7cc or ST7sc control center system, the TIM 4R-IE is connected to the Ethernet card of the control center computer over its Ethernet port.

Installation

When installed separately, the TIM is normally installed on a separate S7-300 standard rail, when necessary along with a power supply module to supply the TIM with 24 V. If the SINAUT MD2, MD3 or MD4 modems are used, they can also be installed on the same rail. The bus module connector supplied with every TIM is not required here since the TIM and modem are always interconnected over the 6NH7701-xxx connecting cable.

TIM 4R-IE with SIMATIC S7-400

The TIM 4R-IE is connected to a SIMATIC S7-400 over one of the Ethernet ports of the TIM. The connection of the S7-400 is via the PROFINET of the CPU or via an Ethernet CP.

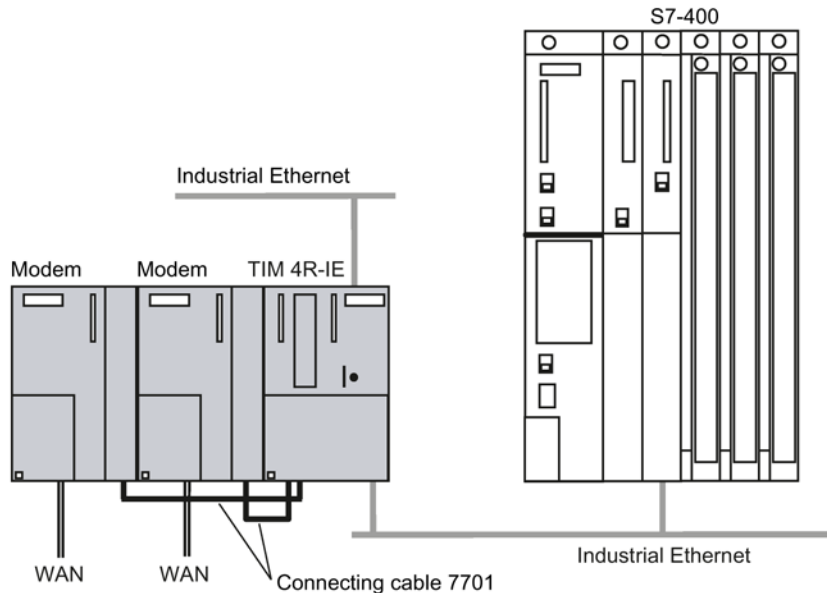

Figure 3-24 SIMATIC S7-400 with TIM 4R-IE connected over Ethernet,
 1 connection to IP-based WAN or LAN,
 2 classic connections to WAN, for example over SINAUT MDx modems

Instead of the MDx SINAUT modem, other modems with an RS-232 or RS-485 interface can also be used, for example wireless devices or the MD720.

Note

Fault-tolerant SINAUT solutions with a CPU 414-4H or CPU 417-4H are not possible.

The maximum number of TIMs that can be connected to S7-400 depends on the connection resources provided by the CPU. With an S7-400, one (1) connection resource is required per TIM. However, the available work memory of the CPU must also be taken into account; the more TIMs installed and stations connected, and the more objects processed per station, the greater the memory demands of the telecontrol-specific user program on the central CPU. This program is put together with blocks from the SINAUT TD7 software package (TD7onCPU).

Example of configurations with the SINAUT ST7cc or ST7sc control center systems

With the SINAUT ST7cc or ST7sc control center system, the TIM 4R-IE is connected to the Ethernet card of the control center computer over one of its Ethernet ports.

The following figure shows a configuration for a control center system SINAUT ST7cc or ST7sc with a TIM 4R-IE connected via Industrial Ethernet.

The control center can communicate with SINAUT subscribers over the TIM 4R-IE. Up to three different networks can be connected: One network could be an IP-based WAN or LAN, the two other networks might be classic SINAUT networks such as dedicated line or telephone network.

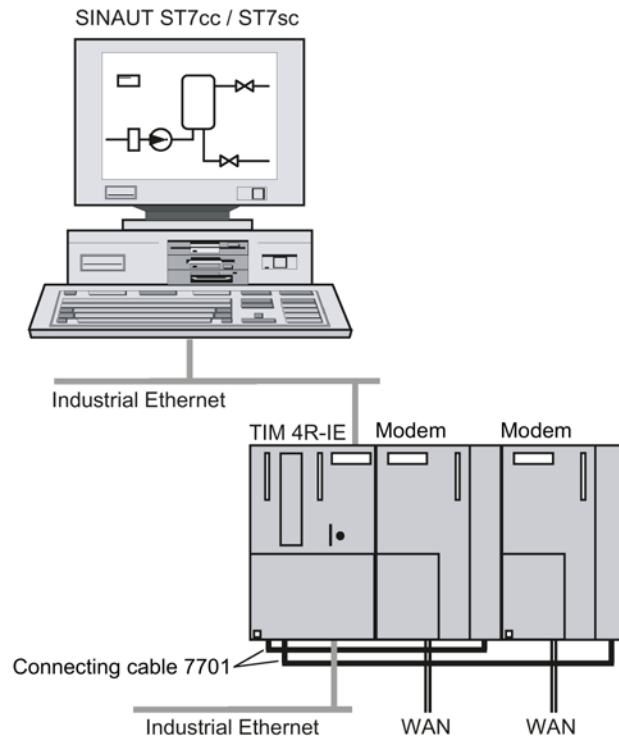

Figure 3-25 SINAUT ST7cc / ST7sc control center system with TIM 4R-IE connected over Ethernet, 1 connection to IP-based WAN or LAN, 2 classic connections to WAN, for example over SINAUT MDx modems

Instead of the MDx SINAUT modem, other modems with an RS-232 or RS-485 interface can also be used, for example wireless devices or the MD720. The RS-485 interfaces of the TIM 4R-IE also provide the option of connecting to a star-shaped dedicated line network with several modems.

Apart from the SINAUT ST7cc / ST7sc control center system, a local controller, for example an S7-400 can also be connected to Ethernet and exchange data with the stations in the telecontrol network. This controller could, for example, be used to display data received from the stations on a panel or console or for emergency input by an operator if ST7cc / ST7sc failed.

The controller could also handle central control tasks such as starting up the system. SINAUT ST7cc / ST7sc and the central controller are then both supplied with parallel data. Both can receive the same data or data specifically intended for one or the other. The transfer of commands, setpoints, parameters etc. to the stations in the telecontrol network is possible from both ST7cc / ST7sc and from the S7-400.

The next figure shows a similar configuration. Here, a redundant SINAUT ST7cc or ST7sc control center system is connected over one of the Ethernet ports.

3.3 Installation guidelines and compatible CPUs

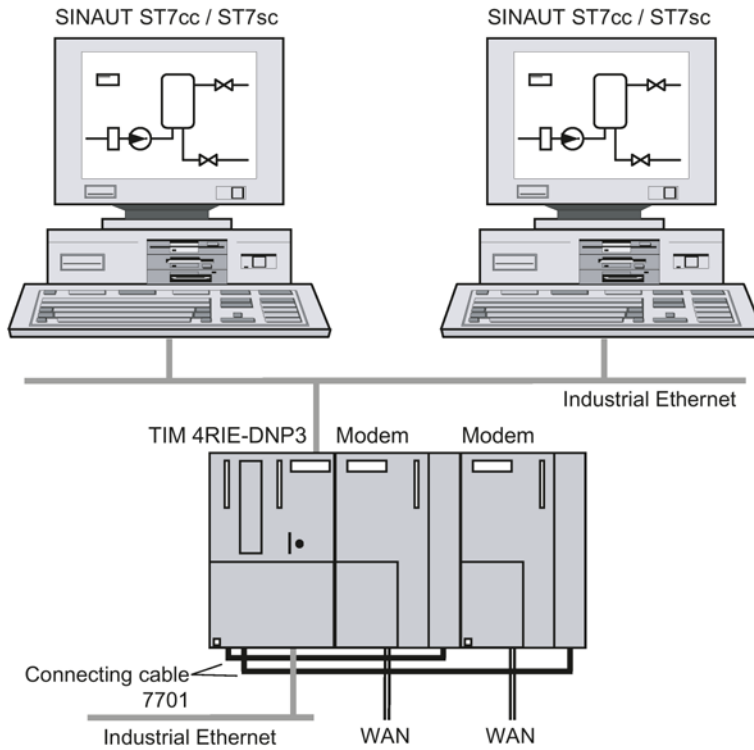

Figure 3-26 Redundant SINAUT ST7cc / ST7sc control center system with TIM 4R-IE connected over Ethernet,
1 connection to IP-based WAN or LAN,
2 classic connections to WAN, for example over SINAUT MDx modems

Installation, connecting up, commissioning

Note

Keep to the installation guide of the SIMATIC S7-300

Modules must be installed according to the installation guidelines of SIMATIC S7-300. You can find information on installation and wiring up in the operating instructions "SIMATIC S7-300, CPU 31xC and CPU 31x: Installation", see /2/ (Page 130).

Safety notices on the use of the device

Note the following safety notices when setting up and operating the device and during all associated work such as installation, connecting up or replacing the device.

4.1 Important notes on using the device

Overvoltage protection

NOTICE
<p>Protection of the external power supply</p> <p>If power is supplied to the module or station over longer power cables or networks, the coupling in of strong electromagnetic pulses onto the power supply cables is possible. This can be caused, for example by lightning strikes or switching of higher loads.</p> <p>The connector of the external power supply is not protected from strong electromagnetic pulses. To protect it, an external overvoltage protection module is necessary. The requirements of EN61000-4-5, surge immunity tests on power supply lines, are met only when a suitable protective element is used. A suitable device is, for example, the Dehn Blitzductor BVT AVD 24, article number 918 422 or a comparable protective element.</p> <p>Manufacturer: DEHN+SOEHNE GmbH+Co.KG Hans Dehn Str.1 Postfach 1640 D-92306 Neumarkt, Germany</p>

Signal cables

Ethernet cables and dedicated copper lines are highly susceptible to electromagnetic interference. Coupling of extraneous voltages can be inductive or capacitive, for example due to the effects of lightning. Direct conductive coupling is also possible due to bad insulation.

The overvoltage protection modules limit extraneous voltage and overvoltage to a non-critical level.

4.1 Important notes on using the device

Fiber-optic cables

Fiber-optic cables are not affected by electromagnetic interference due to the optical transmission principle. Measures for equipotential bonding and overvoltage protection can be omitted for fiber-optic cables.

4.1.1 Notes on use in hazardous areas

 WARNING
The device is intended for indoor use only.

 WARNING
Safety extra low voltage The equipment is designed for operation with Safety Extra-Low Voltage (SELV) by a Limited Power Source (LPS). This means that only SELV / LPS complying with IEC 60950-1 / EN 60950-1 / VDE 0805-1 must be connected to the power supply terminals. The power supply unit for the equipment power supply must comply with NEC Class 2, as described by the National Electrical Code (r) (ANSI / NFPA 70). There is an additional requirement if devices are operated with a redundant power supply: If the equipment is connected to a redundant power supply (two separate power supplies), both must meet these requirements.

 WARNING
EXPLOSION HAZARD Do not open the device when the supply voltage is turned on.

 WARNING
EXPLOSION HAZARD Replacing components may impair suitability for Class 1, Division 2 or Zone 2.

 WARNING
The device may only be operated in an environment with pollution degree 1 or 2 (see IEC 60664-1).

 WARNING
EXPLOSION HAZARD
Do not connect or disconnect cables to or from the device when a flammable or combustible atmosphere is present.

 WARNING
When used in hazardous environments corresponding to Class I, Division 2 or Class I, Zone 2, the device must be installed in a cabinet or a suitable enclosure.

 WARNING
If a device is operated in an ambient temperature of more than 40 °C, the temperature of the device housing may be higher than 70 °C. The device must therefore be installed so that it is only accessible to service personnel or users that are aware of the reason for restricted access and the required safety measures at an ambient temperature higher than 40 °C.

4.1.2 Notes on use in hazardous areas according to ATEX / IECEx

 WARNING
DIN rail
In the ATEX and IECEx area of application only a Siemens DIN rail 6ES7590-1Axx0-0AB0 may be used to mount the TIM.

 WARNING
Requirements for the cabinet
To comply with EC Directive 2014/34 EU (ATEX) or the conditions of IECEx, this enclosure or cabinet must meet the requirements of at least IP54 in compliance with EN 60529.

 WARNING
Cable
If the cable or conduit entry point exceeds 70 °C or the branching point of conductors exceeds 80 °C, special precautions must be taken. If the equipment is operated in an air ambient in excess of 50 °C, only use cables with admitted maximum operating temperature of at least 80 °C.

4.1 Important notes on using the device

 WARNING
Take measures to prevent transient voltage surges of more than 40% of the rated voltage. This is the case if you only operate devices with SELV (safety extra-low voltage).

 WARNING
LAN connection (Local Area Network) A LAN or LAN segment with all the interconnected devices should be contained completely in a single low voltage power distribution system in a building. The LAN is designed either for "Environment A" according to IEEE802.3 or "Environment 0" according to IEC TR 62102. Do not connect any electrical connectors directly to the telephone network (Telephone Network Voltage) or a WAN (Wide Area Network).

 WARNING
EXPLOSION HAZARD Do not press the reset button if there is a potentially explosive atmosphere.

4.1.3 Notes on use in hazardous areas according to UL HazLoc

This equipment is suitable for use in Class I, Division 2, Groups A, B, C and D or non-hazardous locations only.

This equipment is suitable for use in Class I, Zone 2, Group IIC or non-hazardous locations only.

 WARNING
Substitution of components may impair suitability for Division 2.

 WARNING
Substitution of components may impair suitability of the equipment.

 WARNING
EXPLOSION HAZARD You may only connect or disconnect cables carrying electricity when the power supply is switched off or when the device is in an area without inflammable gas concentrations.

 WARNING
EXPLOSION HAZARD
Do not open the device when the supply voltage is turned on.

4.2 Installation

4.2.1 Dimensions of the TIM

Dimensions for installation

The specifications for the installation dimensions of the components are required to design the mechanical structure of a SINAUT ST7 system.

Table 4- 1 Dimensions for installation of the SINAUT ST7 components

Module	Width	Height	Depth	Mounted on
TIM 3V-IE / TIM 3V-IE Advanced	40 mm	125 mm	120 mm with closed front flap Max. 150 mm with open front flap	S7 rail
TIM 4R-IE	80 mm	125 mm	120 mm with closed front flap Max. 180 mm with open front flap	S7 rail

Note the additional space required for the power supply, the CPU, input and output modules and any other modules such as modems.

4.2.2 Mounting position - horizontal / vertical installation

Mounting position

The TIM can be operated both in a horizontal and in a vertical position.

NOTICE

Mounting position - Dependency of the temperature range

Note the dependency of the permitted temperature range of the mounting position.

- Horizontal installation of the rack (DIN rail) means a vertical position of the modules.
- Vertical installation of the rack (DIN rail) means a horizontal position of the modules.

Minimum clearances

Mount the TIM so that its upper and lower ventilation slits are not covered, allowing adequate ventilation as protection from overheating.

Keep to the following minimum clearances for the circulation of air when the rack is installed horizontally:

- Above the TIM: At least 40 mm
- Below the TIM: At least 40 mm

Permitted ambient temperature

The SINAUT ST7 components can be operated in the same temperature range specified for the S7-300.

You can find the permitted temperature ranges in the section Technical specifications (Page 101).

Table 4- 2 Permitted ambient temperatures for the TIM

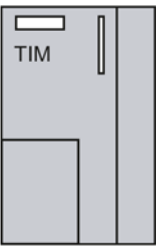
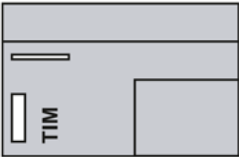
Installation position	Permitted ambient temperature (operation)
 <p>Horizontally installed rack</p>	0 to 60 °C
 <p>Vertically installed rack</p>	0 to 40 °C

4.2.3 Mounting versions

Mounting versions

All TIM types can be installed as a CP in an S7-300 device. With the exception of the TIM 3V-IE, every TIM variant can be operated with several other TIMs in an S7-300 rack.

The TIM 4R-IE can also be installed as a stand-alone device on an S7-300 mounting rail (stand-alone device) and then communicates via Ethernet (TIM 4R-IE) with S7-400 or S7-300 CPU modules and/or a PC control station.

The following sections describe how to mount the devices as a CP or standalone device.

4.2.4 Installing the TIM as a CP

Note

Slots

If a modem is to be installed to the right of the TIM, note that the modem does not have an S7-300 backplane bus. No S7-300 SM, FM or CP that communicates with the CPU over the backplane bus should be installed to the right of the modem.

Note

Only one TIM 3V-IE per rack

Only one single TIM 3V-IE may be installed per S7-300. This means that TIM modules of other types cannot be added either.

Order of installation

To install a TIM as a CP in an S7-300 rack, follow these steps:

1. Turn off the power supply to the CPU.
2. Plug the bus connector, which is included with the TIM, into the rear panel connector to the left of the TIM.

If you want to install further modules to the right of the TIM, insert the bus module connector of the next module into the right backplane connector of the TIM.

3. Place the TIM on the standard rail and push it in towards the bottom.
4. Screw the TIM securely into position.

4.2.5 Installing the TIM 4R-IE as a stand-alone device

Order of installation

Proceed as follows to mount a TIM 4R-IE as a stand-alone device on an S7-300 mounting rail:

1. Place the TIM on the standard rail and push it in towards the bottom.
2. Screw the TIM securely into position.

Proceed accordingly for additional TIM modules. The bus module connector supplied with every TIM is not required. The TIMs are interconnected via Ethernet.

4.3 Connecting up

4.3.1 Connecting the TIM as a CP

Sequence of the connections

After mounting the TIM as a CP in the S7-300 rack, proceed as follows for the connections:

1. Connect the Ethernet cables to the TIM.
2. If you want to connect a modem, plug the socket of the modem connection cable into the TIM's serial interface connector and screw the connection tight.

For the TIM 4R-IE: When connecting a star shaped network, remember to connect the terminating resistor for RS-485 operation of the interface (see below).

NOTICE
Contacting the shield of the cable on the plug
The shield of the cable must be contacted. To do this, strip the insulation from the end of the cable and connect the shield to functional earth.

3. Connect the TIM to the power supply of the CPU.

For more on this, see section Connecting the power supply (Page 94).

4. Close the front flaps.
5. Turn on the power supply.

The TIM starts up.

The LED pattern of the TIM during startup differs from the one in productive operation. For the LED pattern during startup, refer to section Startup behavior of the TIM modules (Page 96).

Then the configuration data (SDBs) must be loaded.

TIM 4R-IE / RS-485: Connection of the terminating resistor

If you connect a star-shaped network with several dedicated line or dial-up network modems to the serial interface of the TIM then operate the serial interface with the RS-485 standard.

You set the RS-485 standard in the configuration of the TIM. With a network operating according to RS-485 you also need to activate the cable terminating resistor of the bus cable in the configuration.

4.3.2 Connecting the stand-alone TIM 4R-IE

Sequence of the connections

After mounting the TIM 4R-IE as a stand-alone device, proceed as follows for the connections:

1. If several TIM modules are installed, connect the modules to each other via Ethernet.
2. Connect the modules to the S7 CPU(s) via Ethernet.
3. Connect the TIM to the LAN or the control station PC via Ethernet.
4. If you want to connect a modem, plug the socket of the modem connection cable into the TIM's serial interface connector and screw the connection tight.

When connecting a star shaped network, remember to connect the terminating resistor for RS-485 operation of the interface (see below).

NOTICE
Contacting the shield of the cable on the plug
The shield of the cable must be contacted. To do this, strip the insulation from the end of the cable and connect the shield to functional earth.

5. Connect the TIM to the power supply.

For more on this, see section Connecting the power supply (Page 94).

Since a stand-alone TIM 4R-IE is a stand-alone TIM rack, it is not necessary to connect the TIM to the power supply of the connected CPU.

6. Close the front flaps.
7. Turn on the power supply.

The TIM starts up.

The LED pattern of the TIM during startup differs from the one in productive operation. For the LED pattern during startup, refer to section Startup behavior of the TIM modules (Page 96).

Then the configuration data (SDBs) must be loaded.

4.3 Connecting up

RS-485: Connection of the terminating resistor

If you connect a star-shaped network with several dedicated line or dial-up network modems to the serial interface of the TIM then operate the serial interface with the RS-485 standard.

You set the RS-485 standard in the configuration of the TIM. With a network operating according to RS-485 you also need to activate the cable terminating resistor of the bus cable in the configuration.

4.3.3 Connection of the MD720 to the TIM and antenna

The following figure shows how the GSM modem MD720 is connected to a TIM over RS-232 and an antenna.

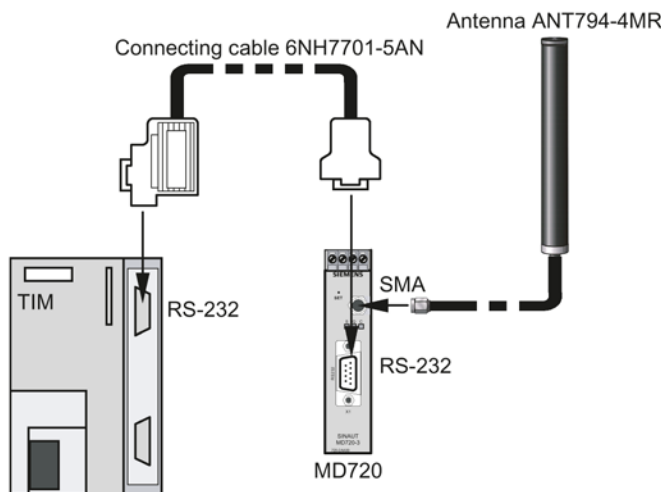

Figure 4-1 Connecting the MD720 to a TIM via RS-232 and the antenna

4.3.4 Connecting the power supply

⚠ WARNING
Connecting with the power supply switched off Connecting the TIM module to a live power supply can damage the module. Connect the module to the power supply only when the power supply is off.
⚠ WARNING
Low voltage (SELV / PELV) The power for the device (24 V DC) must be generated as a safe extra low voltage. This means it must be a SELV (Safety Extra Low Voltage) or PELV (Protective Extra Low Voltage) according to DIN VDE 0100 Part 410 (IEC 60364-4-41).

Note**Common power supply**

If a TIM is installed as a CP in a S7-300 device, then connect the CPU and TIM to a common power supply. This ensures that the CPU and TIM start up simultaneously when the power supply is switched on.

If there are several TIM modules in the rack, you can also connect them to a common power supply.

Cables

To wire the power supply, use flexible cables with a cable cross-section of 0.25 ...0.75 mm².

If you wire only one cable per connection, no wire-end ferrule is necessary.

Wiring**Note**

To avoid ground loops, do not connect the shielding of the TIM.

To wire up the power supply module with a TIM, follow the steps below:

1. Open the front panels of the power supply unit and the TIM.
2. Connect the supply lines "G" and "L+" between the power supply and TIM.
3. Close the front panels.

Wiring diagram

The figure below shows the wiring diagram for one or more TIM modules.

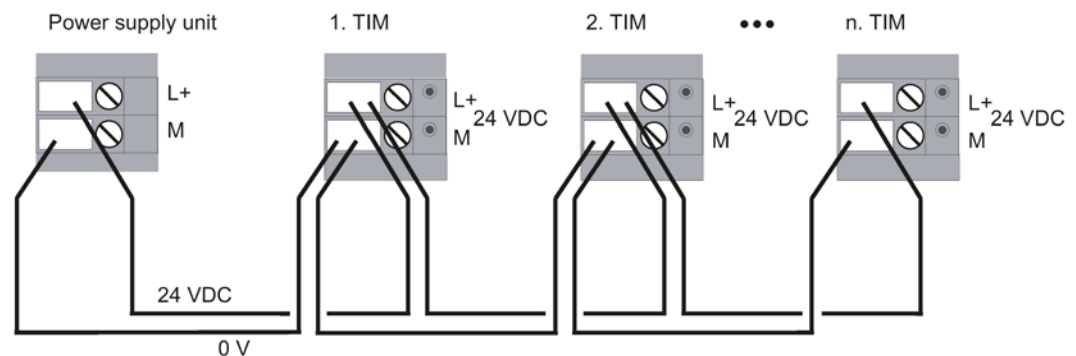

Figure 4-2 Connecting TIM 3V-IE versions and TIM 4R-IE to the power supply

4.4 Configuring and downloading

Configuring the TIM

After startup, the configuration data (SDBs) from STEP 7 must be transferred to the TIM. The configuration data must be set and loading on the station to obtain an operable TIM.

A description of how to configure the TIM can be found in Volume 2 or Volume 3 of the system manual.

The configuration data are stored in the TIM by default.

With an Ethernet TIM, the option for saving the configuration data in the CPU is also offered. With spare parts, this makes it easier to replace a TIM because the new TIM reads the configuration data from the CPU during startup.

The SDBs can also be loaded onto the memory card of the S7-300 CPU.

With the TIM 4R-IE, the SDBs can alternatively be stored on the optional C-PLUG of the TIM. The TIM receives then its configuration data from the CPU during startup or takes it from the inserted C-PLUG.

Downloading the configuration data

Depending on the configuration tool, you can find a description of the download in:

- Volume 2: STEP 7 V5
The configuration data can be loaded via the SINAUT Diagnostics and Service Tool.
- Volume 3: STEP 7 Professional

4.5 Startup behavior of the TIM modules

4.5.1 Startup of the TIM 3V-IE variants

Introduction

During startup, the LEDs on the front panel of the TIM 3V-IE variants have a different significance than during normal operation. They are optical indicators of the various startup phases and provide detailed information about any errors detected during startup. The only exceptions are the LINK and RX/TX LEDs that have no significance during the startup of the TIM 3V-IE variants.

LED displays during startup

The following table summarizes the startup phases.

Table 4- 3 LED activity of TIM 3V-IE versions during startup

Phase	Activity	SF	RUN	STOP	KBus	TxD	RxD
1	Power ON followed by hardware initialization	On	On	On	On	On	On
2	Loading the operating system from flash memory	Off	On	On	On	On	On
3	Starting VxWorks operating system	Off	Off	On	On	On	On
4	Loading and starting TIM firmware	Off	Off	Off	On	On	On
5	Initializing flash file system and starting the start manager	Off	Flashes	On	Off	Off	Off
6	Loading and starting P bus driver	Off	Flashes	On	On	Off	Off
7	Loading and starting subscriber management (SubA)	Off	Flashes	On	Off	On	Off
8	Loading and starting LAN-COM	Off	Flashes	On	On	On	Off
9	Loading and starting subscriber management (MesA)	Off	Flashes	On	Off	Off	On
10	Loading and starting time-of-day driver	Off	Flashes	On	On	Off	On
11	Loading and starting the TD7 software of the TIM (TD7onTIM) on the TIM	Off	Flashes	On	Off	On	On
12	Loading and starting WAN driver	Off	Flashes	On	On	On	On
13a	Startup completed without error	Off	On	Off	X ¹⁾	X ¹⁾	X ¹⁾
13b	Startup completed with error	On	Off	On	X ²⁾	X ²⁾	X ²⁾
13c	Startup aborted, configuration data missing. TIM expects configuration data (SDBs).	Off	Off	On	Flashes	Flashes	On
13d	Startup aborted - No firmware loaded	Off	Off	On	On	Flashes	Flashes
13e	Startup aborted - No SDBs and no firmware loaded	Off	Off	On	Flashes	Flashes	Flashes
13f	Default startup completed (see below)	Off	Flashes	Flashes	On	On	On
13g	Startup aborted due to incorrect firmware (firmware does not match module type)	On	Flashes	Flashes	Flashes	Flashes	Flashes

1) The LEDs KBus, TxD and RxD now operate in normal mode

2) The LEDs KBus, TxD and RxD remain in the phase in which the error occurred

Group error LED

If a problem occurs during startup, the red group error LED (SF) lights up and a diagnostic interrupt is sent to the CPU. In addition, a message is entered in the diagnostic buffer of the TIM. In the section on the SINAUT Diagnostics and Service Tool in Volume 2 of the system manual, you can find all the error messages that cause the group error LED (SF) to light up.

Note

After transferring the SDBs to the TIM, the group error LED flashes for approximately 10 seconds. This indicates that the TIM has registered the transfer and will automatically start a reset after a further 10 seconds and the parameter assignment from the newly transferred SDBs will be adopted. The TIM then behaves the same as following power "ON".

Reset with forced default startup

After resetting the TIM with the reset button, the TIM performs a default startup. To initiate the default startup and the effects associated with it, see section Reset button (Page 48).

4.5.2 Startup activities of the TIM 4R-IE

Introduction

During startup, the LEDs on the front panel of the TIM 4R-IE have a different significance than during normal operation. They are optical indicators of the various startup phases and provide detailed information about any errors detected during startup. During startup on the TIM 4R-IE, the "BATF", "P1" and "P2" LEDs have no significance.

LED displays during startup

The following table summarizes the startup phases.

Table 4- 4 LED activity of TIM 4R-IE during startup

Phase	Activity	SF	RUN	STOP	KBUS	TXD1	RXD1	TXD2	RXD2
1	Power ON, followed by hardware initialization	On	On	On	On	On	On	On	On
2	Loading the operating system from flash memory	Off	On	On	On	On	On	On	On
3	Starting VxWorks operating system	Off	Off	On	On	On	On	On	On
4	Loading and starting TIM firmware	Off	Off	Off	On	On	On	On	On
5	Initializing flash file system and starting the start manager	Off	Flashes	On	Off	Off	Off	Off	Off
6	Loading and starting P bus driver	Off	Flashes	On	On	Off	Off	Off	Off

Phase	Activity	SF	RUN	STOP	KBUS	TXD1	RXD1	TXD2	RXD2
7	Loading and starting subscriber management (SubA)	Off	Flashes	On	Off	On	Off	Off	Off
8	Loading and starting LAN-COM	Off	Flashes	On	On	On	Off	Off	Off
9	Loading and starting subscriber management (MesA)	Off	Flashes	On	Off	Off	On	Off	Off
10	Loading and starting time-of-day driver	Off	Flashes	On	On	Off	On	Off	Off
11	Loading and starting the TD7 software of the TIM (TD7onTIM) on the TIM	Off	Flashes	On	Off	On	On	Off	Off
12	Loading and starting WAN driver	Off	Flashes	On	On	On	On	Off	Off

You can find the LED pattern following a completed or aborted startup in the following table.

Table 4- 5 LED activity on the TIM 4R-IE after a completed or aborted startup

Phase	Status	SF	RUN	STOP	KBUS	TXD1	RXD1	TXD2	RXD2
13	Startup completed or aborted								
13a	Startup completed without error	Off	On	Off	X ¹⁾	X ¹⁾	X ¹⁾	X ¹⁾	X ¹⁾
13b	Startup completed with error	On	Off	On	X ²⁾	X ²⁾	X ²⁾	X ²⁾	X ²⁾
13c	Startup aborted, configuration data missing. TIM expects configuration data (SDBs).	Off	Off	On	On	Flashes	On	Flashes	On
13d	Startup aborted - No firmware loaded.	Off	Off	On	Flashes	On	Flashes	On	Flashes
13e	Startup aborted - No SDBs and no firmware loaded	Off	Off	On	Flashes	Flashes	Flashes	Flashes	Flashes
13f	Default startup completed (see below)	Off	Flashes	Flashes	On	On	On	On	On
13g	Automatic default startup completed (see below)	On	Flashes	Flashes	On	On	On	On	On
13h	Startup aborted due to incorrect firmware (firmware does not match module type)	On	Flashes	Flashes	Flashes	Flashes	Flashes	Flashes	Flashes

¹⁾ The LEDs operate in normal mode

²⁾ The LEDs remain in the phase in which the error occurred.

Group error LED

If an error occurs during startup, the red group error LED (SF) lights up and, if the TIM is installed as a CP in an S7-300, a diagnostic interrupt is sent to the CPU. In addition, a message is entered in the diagnostic buffer of the TIM. In the section on the SINAUT Diagnostics and Service Tool in Volume 2 of the system manual, you can find all the error messages that cause the group error LED (SF) to light up.

Note

After transferring the SDBs to the TIM, the group error LED flashes for approximately 10 seconds. This indicates that the TIM has registered the transfer and will automatically start a reset after a further 10 seconds and the parameter assignment from the newly transferred SDBs will be adopted. The TIM then behaves the same as following power "ON".

Reset with forced default startup

After resetting the TIM with the reset button, the TIM performs a default startup. To initiate the default startup and the effects associated with it, see section Reset button (Page 48).

Automatic default startup

A TIM 4R-IE configured for operation along with a CPU in the rack but that starts up in standalone mode, runs "Automatic default startup".

Following the aborted startup, the LED pattern of the TIM appears as shown in row 13g of the table.

Although the TIM 4R-IE can then be assessed for loading, it does not perform any further functions.

Technical specifications

5.1 Technical specifications of the TIM 3V-IE variants

Technical specifications of the TIM 3V-IE

Technical specifications - TIM 3V-IE		
Article number	6NH7800-3BA00	
Attachment to Industrial Ethernet		
Quantity	1 x Fast Ethernet interface (X2)	
Design	RJ45 jack, galvanically isolated	
Properties	Half duplex/full duplex, autocrossover, autonegotiation	
Standard	100BASE-TX, IEEE 802.3-2005	
Transmission speeds	10 / 100 Mbps	
Permitted cable lengths (Ethernet)	(Alternative combinations per length range) *	
0 ... 55 m	<ul style="list-style-type: none"> • Max. 55 m IE TP Torsion Cable with IE FC RJ45 Plug 180 • Max. 45 m IE TP Torsion Cable with IE FC RJ45 + 10 m TP Cord via IE FC RJ45 Outlet 	
0 ... 85 m	<ul style="list-style-type: none"> • Max. 85 m IE FC TP Marine/Trailing/Flexible/FRNC/Festoon/Food Cable with IE FC RJ45 Plug 180 • Max. 75 m IE FC TP Marine/Trailing/Flexible/FRNC/Festoon/Food Cable + 10 m TP Cord via IE FC RJ45 Outlet 	
0 ... 100 m	<ul style="list-style-type: none"> • Max. 100 m IE FC TP Standard Cable with IE FC RJ45 Plug 180 • Max. 90 m IE FC TP Standard Cable + 10 m TP Cord via IE FC RJ45 Outlet 	
Serial interface for connection to the transmission device		
Quantity	1 x serial interface (X1)	
Design	9-pin D-sub male connector, isolated	
Standard	RS-232	
Transmission speeds	300 to 38400 bps (depending on the connected modem)	
Maximum cable length	6 m	
Power supply		
Design	2-pin plug-in terminal strip	
Power supply	<ul style="list-style-type: none"> • Type of voltage • Permitted low limit • Permitted high limit 	<ul style="list-style-type: none"> • 24 VDC • 20.4 V • 28.8 V
Cable cross-section connectable to the terminal block	<ul style="list-style-type: none"> • Without wire end ferrule • With wire end ferrule • With TWIN wire end ferrule 	<ul style="list-style-type: none"> • 0.2 .. 2.5 mm² / AWG 24 .. 13 • 0.25 .. 1.5 mm² / AWG 24 .. 16 • 0.5 .. 1.0 mm² / AWG 20 .. 17

Technical specifications - TIM 3V-IE

Further electrical data

Current consumption	<ul style="list-style-type: none"> From backplane bus From 24 V DC 	<ul style="list-style-type: none"> 200 mA Typ. 160 mA, max. 200 mA
---------------------	--	--

Effective power loss (typical)	5.8 W
--------------------------------	-------

Overvoltage category according to IEC / EN 60664-1	Category I
--	------------

Permitted ambient conditions

Ambient temperature	During operation with the rack installed horizontally	0 °C ... +60 °C
	During operation with the rack installed vertically	0 °C ... +40 °C
	During storage	-40 °C to +70 °C
	During transportation	-40 °C to +70 °C
Relative humidity	During operation	Max. 95 % at +25 °C, no condensation
Permitted contaminant concentration	Corrosive gas test according to ISA-S71.04 severity level G1, G2, G3	
	SO ₂	< 0.5 ppm
	H ₂ S	< 0.1 ppm

Design, dimensions and weight

Module format	Compact module for S7-300, single width
Degree of protection	IP20
Weight	250 g
Dimensions (W x H x D)	40 x 125 x 120 mm
Installation options	35 mm standard mounting rail for SIMATIC S7-300

Product functions **

No. of TIM 3V-IE modules per S7-300	1	
Supported network node types	Station	Yes
	Node station	No
	Master station	No

Configuration limits

Message memory on TIM	Number of messages	16000 data frames
	Buffered	No
Max. number of connections, depending on the interface used:	S7 communication	Max. 8
	MSC connections	Max. 1 (only as MSC station)
	PG communication	Max. 2

Communication via Ethernet interface

Protocol	TCP/IP transport protocol
Communication services	<ul style="list-style-type: none"> SINAUT ST7 using S7 communication PG communication

Communication via serial interface

Technical specifications - TIM 3V-IE

Selectable protocols	<ul style="list-style-type: none"> • SINAUT ST7 • SINAUT ST1 	
Communications services	<ul style="list-style-type: none"> • SINAUT ST7 via MSC tunnel • PG communication 	
Mode with dedicated line/wireless network	With SINAUT ST7 protocol	<ul style="list-style-type: none"> • Polling • Polling with time slots • Multi-master polling with time slots
	With SINAUT ST1 protocol	<ul style="list-style-type: none"> • Polling • Polling with time slots
Mode in dial-up network	<ul style="list-style-type: none"> • SINAUT ST7 protocol • GPRS/MSC on ST7 • SINAUT ST1 protocol 	<ul style="list-style-type: none"> • Spontaneous • Spontaneous • Spontaneous
Asynchronous character format	<ul style="list-style-type: none"> • ST7 protocol, polling / spontaneous • ST7 protocol, multi-master polling • ST1 protocol, polling • ST1 protocol, spontaneous 	<ul style="list-style-type: none"> • 10 or 11 bits • 10 bits • 11 bits • 10 or 11 bits
Hamming distance d	• SINAUT ST7 protocol	• 4
	• SINAUT ST1 protocol	• 4

Additional functions

Use of serial and Ethernet interface	Alternative:	<ul style="list-style-type: none"> • Serial interface or • Ethernet interface
Configuration	Software, alternative:	<ul style="list-style-type: none"> • STEP 7 V5 + SINAUT Engineering Software • STEP 7 Professional in the TIA Portal
	TD7 software for CPU (optional)	TD7 block library for CPU
	Storage of TIM configuration data, alternative:	<ul style="list-style-type: none"> • On internal TIM flash memory • On MMC of the S7-300 CPU
Local communication	Over backplane bus with the S7-300 CPU	Possible with TD7onCPU and TD7onTIM
	Over backplane bus with other TIMs in the rack	Not possible
	Over MPI interface of the S7-300 CPU *** with additional CPUs, TIMs and/or PCs	Not possible

5.1 Technical specifications of the TIM 3V-IE variants

Technical specifications - TIM 3V-IE		
Work memory required on the S7 CPU	TD7onCPU	At least 20 KB; actual requirements depend on the amounts of data and scope of functions
	TD7onTIM	Best case, 0 bytes

* For details, refer to the catalog IK PI, Cabling Technology

** You can find additional properties and performance data in the section TIM 3V-IE / TIM 3V-IE Advanced (Page 37).

*** The MPI interface of the CPU can also be used with S7-300-CPU's with a partyline, see section Installing the TIM 3V-IE variants in an S7-300 (Page 61).

Technical specifications of the TIM 3V-IE Advanced

Technical specifications - TIM 3V-IE Advanced		
Article number	6NH7800-3CA00	
Attachment to Industrial Ethernet		
Quantity	1 x Fast Ethernet interface (X2)	
Design	RJ45 jack, galvanically isolated	
Properties	Half duplex/full duplex, autocrossover, autonegotiation	
Standard	100BASE-TX, IEEE 802.3-2005	
Transmission speeds	10 / 100 Mbps	
Permitted cable lengths (Ethernet)	(Alternative combinations per length range) *	
0 ... 55 m	<ul style="list-style-type: none"> • Max. 55 m IE TP Torsion Cable with IE FC RJ45 Plug 180 • Max. 45 m IE TP Torsion Cable with IE FC RJ45 + 10 m TP Cord via IE FC RJ45 Outlet 	
0 ... 85 m	<ul style="list-style-type: none"> • Max. 85 m IE FC TP Marine/Trailing/Flexible/FRNC/Festoon/Food Cable with IE FC RJ45 Plug 180 • Max. 75 m IE FC TP Marine/Trailing/Flexible/FRNC/Festoon/Food Cable + 10 m TP Cord via IE FC RJ45 Outlet 	
0 ... 100 m	<ul style="list-style-type: none"> • Max. 100 m IE FC TP Standard Cable with IE FC RJ45 Plug 180 • Max. 90 m IE FC TP Standard Cable + 10 m TP Cord via IE FC RJ45 Outlet 	
Serial interface for connection to the transmission device		
Quantity	1 x serial interface (X1)	
Design	9-pin D-sub male connector, isolated	
Standard	RS-232	
Transmission speeds	300 to 38400 bps (depending on the connected modem)	
Maximum cable length	6 m	
Power supply		
Design	2-pin plug-in terminal strip	
Power supply	<ul style="list-style-type: none"> • Type of voltage • Permitted low limit • Permitted high limit 	<ul style="list-style-type: none"> • 24 VDC • 20.4 V • 28.8 V

Technical specifications - TIM 3V-IE Advanced

Cable cross-section connectable to the terminal block	<ul style="list-style-type: none"> Without wire end ferrule With wire end ferrule With TWIN wire end ferrule 	<ul style="list-style-type: none"> 0.2 .. 2.5 mm² / AWG 24 .. 13 0.25 .. 1.5 mm² / AWG 24 .. 16 0.5 .. 1.0 mm² / AWG 20 .. 17
---	---	---

Further electrical data

Current consumption	<ul style="list-style-type: none"> From backplane bus From 24 V DC 	<ul style="list-style-type: none"> 200 mA Typ. 160 mA, max. 200 mA
---------------------	--	--

Effective power loss (typical)	5.8 W
--------------------------------	-------

Overvoltage category according to IEC / EN 60664-1	Category I
--	------------

Permitted ambient conditions

Ambient temperature	During operation with the rack installed horizontally	0 °C ... +60 °C
	During operation with the rack installed vertically	0 °C ... +40 °C
	During storage	-40 °C to +70 °C
	During transportation	-40 °C to +70 °C

Relative humidity	During operation	Max. 95 % at +25 °C, no condensation
-------------------	------------------	--------------------------------------

Permitted contaminant concentration	Corrosive gas test according to ISA-S71.04 severity level G1, G2, G3	
	• SO ₂	• < 0.5 ppm
	• H ₂ S	• < 0.1 ppm

Design, dimensions and weight

Module format	Compact module for S7-300, single width
Degree of protection	IP20
Weight	250 g
Dimensions (W x H x D)	40 x 125 x 120 mm
Installation options	35 mm standard mounting rail for SIMATIC S7-300

Product functions **

No. of TIM 3V-IE Advanced modules per S7-300	Multiple: Number depends on the communication resources of the S7-300 CPU	
--	---	--

Supported network node types	• Station	• Yes
	• Node station	• Yes
	• Master station	• Yes

Configuration limits

Message memory on TIM	• Number of messages	• 32000 frames
	• Buffered	• No

Max. number of connections, depending on the interface used:	• S7 communication	• Max. 24
	• MSC connections	• Max. 1 (only as MSC station)
	Total number of simultaneously operable productive connections (S7 + MSC)	Max. 25

Technical specifications - TIM 3V-IE Advanced		
	<ul style="list-style-type: none"> PG communication 	<ul style="list-style-type: none"> Max. 4
Communication via Ethernet interface		
Protocol	TCP/IP transport protocol	
Communication services	<ul style="list-style-type: none"> SINAUT ST7 using S7 communication PG communication 	
Communication via serial interface		
Selectable protocols	<ul style="list-style-type: none"> SINAUT ST7 SINAUT ST1 	
Communication services	<ul style="list-style-type: none"> SINAUT ST7 via MSC tunnel PG communication 	
Mode with dedicated line/wireless network	With SINAUT ST7 protocol	<ul style="list-style-type: none"> Polling Polling with time slots Multi-master polling with time slots
	With SINAUT ST1 protocol	<ul style="list-style-type: none"> Polling Polling with time slots
Mode in dial-up network	<ul style="list-style-type: none"> SINAUT ST7 protocol GPRS/MSC on ST7 SINAUT ST1 protocol 	<ul style="list-style-type: none"> Spontaneous Spontaneous Spontaneous
Asynchronous character format	<ul style="list-style-type: none"> ST7 protocol, polling / spontaneous ST7 protocol, multi-master polling ST1 protocol, polling ST1 protocol, spontaneous 	<ul style="list-style-type: none"> 10 or 11 bits 10 bits 11 bits 10 or 11 bits
Hamming distance d	<ul style="list-style-type: none"> SINAUT ST7 protocol SINAUT ST1 protocol 	<ul style="list-style-type: none"> 4 4
Additional functions		
Use of serial and Ethernet interface	Simultaneously possible	
Configuration	Software, alternative:	<ul style="list-style-type: none"> STEP 7 V5 + SINAUT Engineering Software STEP 7 Professional in the TIA Portal
	TD7 software for CPU (optional)	TD7 block library for CPU
Storage of TIM configuration data, alternative:		<ul style="list-style-type: none"> On internal TIM flash memory On MMC of the S7-300 CPU
Local communication	Over backplane bus with the S7-300 CPU	Possible with TD7onCPU and TD7onTIM
	Over backplane bus with other TIMs in the rack	Possible

Technical specifications - TIM 3V-IE Advanced

	Over MPI interface of the S7-300-CPU *** with additional CPUs, TIMs and/or PCs	<ul style="list-style-type: none"> • Over TD7onCPU for S7-300 and S7-400 • Over S7 communication for ST7cc/ST7sc and TIMs
	Over Ethernet interface with CPUs, PCs and additional TIMs	<ul style="list-style-type: none"> • Over TD7onCPU for S7-400 • Over S7 communication for ST7cc/ST7sc and TIMs
Work memory required on the S7 CPU	TD7onCPU	At least 20 KB; actual requirements depend on the amounts of data and scope of functions
	TD7onTIM	Best case, 0 bytes

* For details, refer to the catalog IK PI, Cabling Technology

** You can find additional properties and performance data in the section TIM 3V-IE / TIM 3V-IE Advanced (Page 37).

*** The MPI interface of the CPU can also be used with S7-300-CPU's with a partyline, see section Installing the TIM 3V-IE variants in an S7-300 (Page 61).

5.2 Technical specifications of the TIM 4R-IE

Technical specifications of the TIM 4R-IE

Technical specifications - TIM 4R-IE	
Article number	6NH7800-4BA00
Attachment to Industrial Ethernet	
Quantity	2 x Fast Ethernet interface (X3 / X4)
Design	RJ45 jack, galvanically isolated
Properties	Half duplex/full duplex, autocrossover, autonegotiation
Standard	100BASE-TX, IEEE 802.3-2005
Transmission speeds	10 / 100 Mbps
Permitted cable lengths (Ethernet)	(Alternative combinations per length range) *
0 ... 55 m	<ul style="list-style-type: none"> Max. 55 m IE TP Torsion Cable with IE FC RJ45 Plug 180 Max. 45 m IE TP Torsion Cable with IE FC RJ45 + 10 m TP Cord via IE FC RJ45 Outlet
0 ... 85 m	<ul style="list-style-type: none"> Max. 85 m IE FC TP Marine/Trailing/Flexible/FRNC/Festoon/Food Cable with IE FC RJ45 Plug 180 Max. 75 m IE FC TP Marine/Trailing/Flexible/FRNC/Festoon/Food Cable + 10 m TP Cord via IE FC RJ45 Outlet
0 ... 100 m	<ul style="list-style-type: none"> Max. 100 m IE FC TP Standard Cable with IE FC RJ45 Plug 180 Max. 90 m IE FC TP Standard Cable + 10 m TP Cord via IE FC RJ45 Outlet
Serial interfaces for connection to the transmission equipment	
Quantity	2 x serial interface (X1 / X2)
Design	9-pin D-sub male connector, isolated
standards, can be changed via configuration	<ul style="list-style-type: none"> RS-232 RS-485
Transmission speeds	300 to 115200 bps (depending on the connected modem)
Maximum cable length, depending on interface standard	<ul style="list-style-type: none"> RS-232 <ul style="list-style-type: none"> 6 m RS-485 <ul style="list-style-type: none"> 30 m
Memory, clock, battery	
Slot for C-PLUG removable media	(C-PLUG optional)
Clock	<ul style="list-style-type: none"> Hardware clock (real-time clock) <ul style="list-style-type: none"> Yes Backup <ul style="list-style-type: none"> Yes (with backup battery) Deviation per day <ul style="list-style-type: none"> Max. 4 s

Technical specifications - TIM 4R-IE

Backup battery (optional) for message memory and hardware clock	<ul style="list-style-type: none"> Battery type Article number Voltage / capacity Current consumption during backup Leakage current 	<ul style="list-style-type: none"> Lithium battery, Tadiran SL-306, cell type AA 6ES7971-0BA00 3.6 V nom. / 2.3 Ah Typically 100 µA, max. 160 µA Typ. 15 µA
---	--	--

Power supply

Design	2-pin plug-in terminal strip	
Power supply	<ul style="list-style-type: none"> Type of voltage Permitted low limit Permitted high limit 	<ul style="list-style-type: none"> 24 VDC 20.4 V 28.8 V
Cable cross-section connectable to the terminal block	<ul style="list-style-type: none"> Without wire end ferrule With wire end ferrule With TWIN wire end ferrule 	<ul style="list-style-type: none"> 0.2 .. 2.5 mm² / AWG 24 .. 13 0.25 .. 1.5 mm² / AWG 24 .. 16 0.5 .. 1.0 mm² / AWG 20 .. 17

Further electrical data

Current consumption	<ul style="list-style-type: none"> From backplane bus From 24 V DC 	<ul style="list-style-type: none"> Max. 200 mA Typically 150 mA, max. 170 mA
Effective power loss (typical)	4.6 W	
Overvoltage category according to IEC / EN 60664-1	Category I	

Permitted ambient conditions

Ambient temperature	During operation with the rack installed horizontally	0 °C ... +60 °C
	During operation with the rack installed vertically	0 °C ... +40 °C
	During storage	-40 °C to +70 °C
	During transportation	-40 °C to +70 °C
Relative humidity	During operation	Max. 95 % at +25 °C, no condensation
Permitted contaminant concentration	Corrosive gas test according to ISA-S71.04 severity level G1, G2, G3	
	<ul style="list-style-type: none"> SO₂ H₂S 	<ul style="list-style-type: none"> < 0.5 ppm < 0.1 ppm

Design, dimensions and weight

Module format	Compact module for S7-300, double width
Degree of protection	IP20
Weight	400 g
Dimensions (W x H x D)	80 x 125 x 120 mm
Installation options	35 mm standard mounting rail for SIMATIC S7-300

Product functions **

No. of TIM 4R-IE modules per S7-300/400	Multiple: Number depends on the communication resources of the S7-300 CPU
---	---

Technical specifications - TIM 4R-IE

Supported network node types	<ul style="list-style-type: none"> • Station • Node station • Master station 	<ul style="list-style-type: none"> • Yes • Yes • Yes
Configuration limits		
Message memory on TIM	<ul style="list-style-type: none"> • Number of messages • Backup 	<ul style="list-style-type: none"> • 56000 frames • Yes (with backup battery)
Max. number of connections, depending on the interface used: (sum of S7 + MSC connections operated simultaneously)	<ul style="list-style-type: none"> • S7 communication • MSC connections <ul style="list-style-type: none"> – As MSC master station – As MSC station Total S7 + MSC connections <ul style="list-style-type: none"> • As MSC master station • As MSC station • PG communication 	<ul style="list-style-type: none"> • Max. 64 • Depending on the network node type: <ul style="list-style-type: none"> – Max. 128 – Max. 1 • Max. 128 • Max. 65 • Max. 2
Communication via Ethernet interface		
Protocol	TCP/IP transport protocol	
Communication services	<ul style="list-style-type: none"> • SINAUT ST7 using S7 communication • SINAUT ST7 via MSC tunnel • PG communication 	
Communication via serial interface (RS-232 / RS-485)		
Selectable protocols	<ul style="list-style-type: none"> • SINAUT ST7 • SINAUT ST1 	
Communication services	<ul style="list-style-type: none"> • SINAUT ST7 via MSC tunnel • PG communication 	
Mode with dedicated line/wireless network	With SINAUT ST7 protocol	<ul style="list-style-type: none"> • Polling • Polling with time slots • Multi-master polling with time slots
	With SINAUT ST1 protocol	<ul style="list-style-type: none"> • Polling • Polling with time slots
Mode in dial-up network	<ul style="list-style-type: none"> • SINAUT ST7 protocol • GPRS/MSC on ST7 • SINAUT ST1 protocol 	<ul style="list-style-type: none"> • Spontaneous • Spontaneous • Spontaneous
Asynchronous character format	<ul style="list-style-type: none"> • ST7 protocol, polling / spontaneous • ST7 protocol, multi-master polling • ST1 protocol, polling • ST1 protocol, spontaneous 	<ul style="list-style-type: none"> • 10 or 11 bits • 10 bits • 11 bits • 10 or 11 bits

Technical specifications - TIM 4R-IE

Hamming distance d	• SINAUT ST7 protocol	• 4
	• SINAUT ST1 protocol	• 4

Local communication

General	Over Ethernet interface with CPUs, PCs and additional TIMs	<ul style="list-style-type: none"> • Over TD7onCPU for S7-400 • Over S7 communication for ST7cc/ST7sc and TIMs
When used in an S7-300	Over backplane bus with the S7-300 CPU	Possible (TD7onCPU or TD7onTIM)
	Over backplane bus with other TIMs in the rack	Possible
	Over MPI interface of the S7-300 CPU *** with additional CPUs, TIMs and/or PCs	Possible over TD7onCPU (for S7-300 and S7-400) and S7 communication (for ST7cc/ST7sc and TIMs)

Configuration and memory requirement

Configuration	Software, alternative:	<ul style="list-style-type: none"> • STEP 7 V5 + SINAUT Engineering Software • STEP 7 Professional / TIA Portal
	TD7 block library for CPU (optional), alternatively in:	<ul style="list-style-type: none"> • STEP 7 V5 (SINAUT TD7 Library) • STEP 7 Professional / TIA Portal
	Storage of TIM configuration data, alternative:	<ul style="list-style-type: none"> • On internal TIM flash memory • On optional C-PLUG of the TIM • On MMC of the S7-300 CPU
Work memory required on the S7 CPU	TD7onCPU	At least 20 KB; actual requirements depend on the amounts of data and scope of functions
	TD7onTIM	Best case, 0 bytes

* For details, refer to the catalog IK PI, Cabling Technology

** You can find additional properties and performance data in the section TIM 4R-IE (Page 43).

*** The MPI interface of the CPU can also be used with S7-300-CPU's with a partyline, see section Installing the TIM 4R-IE in an S7-300 (Page 70).

5.3 Current consumption and power loss of the SINAUT ST7 components

Introduction

The SINAUT ST7 components obtain the current required for operation from an external power supply. When a TIM is installed in an S7-300, it also consumes electricity via the S7-300 backplane bus.

You require the information on current consumption of the SINAUT ST7 components from the external load power supply and from the backplane bus, for example, to configure the cabinet for a SINAUT ST7 station control device.

Current consumption and power loss

The following table lists the current consumption and power loss of the TIM and modem components.

Table 5- 1 Power consumption and power dissipation of various components

Module	Article number	Current consumption from backplane bus (max.)	Current consumption from 24 V load power supply	Power loss (nominal)
TIM 3V-IE	6NH7800-3BA00	200 mA	160 mA	5.8 W
TIM 3V-IE Adv.	6NH7800-3CA00	200 mA	160 mA	5.8 W
TIM 4R-IE	6NH7800-4BA00	200 mA	170 mA	4.6 W
MD2	6NH7810-0AA20	-	100 mA	2.4 W
MD3	6NH7810-0AA30	-	200 mA	4.8 W
MD4	6NH7810-0AA40	-	100 mA	2.4 W
MD741-1	6NH9741-1AA00	-	137...182 mA *	4 W
MD720	6NH9720-3AA01-0XX0	-	135...215 mA *	3.4 W

* Depending on operating mode

Example

An S7-300 is configured with the following modules:

- 1 power supply PS 307; 2 A
- 1 CPU 314
- 2 digital input modules SM 321; DI 16 x DC 24 V
- 1 relay module SM 322; DO 8 x AC 230 V/5 A
- 1 analog input module SM 331; AI 8 x 12 bits
- 1 analog output module SM 332; AO 2 x 12 bits
- 1 communications module TIM 4R
- 1 modem MD3

Calculation of the current and power loss balance

The following table contains the power consumption and loss balance for the S7- 300 configuration described above. This current consumption and power loss balance does not include any actuators connected to the outputs.

Table 5- 2 Current consumption and power loss balance

Module	Current consumption from S7-300 backplane bus	Current consumption from 24 V load power supply	Power loss
Power supply PS 307; 2 A	-	-	10 W
CPU 314	-	700 mA	8 W
2 digital input modules SM 321; DI 16 x DC 24 V	(2 x 25 mA) = 50 mA	(2 x 25 mA) = 50 mA	(2 x 3.5 W) = 7 W
1 relay module SM 322; DO 8 x AC 230 V/5 A	40 mA	125 mA	4.2 W
1 analog input module SM 331; AI 8 x 12 bits	60 mA	200 mA	1.3 W
1 analog output module SM 332; AO 2 x 12 bits	60 mA	135 mA	3 W
1 communication module TIM 4R-IE	200 mA	170 mA	4.6 W
1 modem MD3	-	200 mA	4.8 W
Total:	410 mA	1580 mA	42.9 W

Result

The following results can be derived from the table above:

- Current consumption from S7-300 backplane bus:
The current consumption of the signal and TIM modules from the backplane bus amounts to a total of 410 mA. It therefore does not exceed the 1.2 A that the CPU 314 can supply to the backplane bus.
- Current consumption from the 24 V power supply:
The current consumption of the signal, TIM and modem modules from the 24 V load power supply amounts to approx. 1.6 A. You must also consider all other connected loads. Depending on this, you can then select the PS 307 power supply. The PS 307 unit with 2 A output current would just be sufficient for the controller components (without connected actuators) in this example.
- Power loss:
The power loss of the S7-300 configuration amounts to a total of 42.9 W. The power loss of all the components used in a cabinet must not exceed the maximum available power of the cabinet.

Note

When planning the dimensions of the cabinet, make sure that the temperature in the cabinet does not exceed the permitted maximum of 60°C even when the temperature outside the cabinet is high.

5.4 Interface allocation

Serial interfaces (RS-232/RS-485)

The serial interfaces are designed as 9-pin D-sub miniature connectors (male).

As an RS-232 interface, the pin assignment corresponds to that of a standardized PC connector.

With the TIM 4R-IE, the interface standard in the configuration can be switched from RS-232 to RS-485 and is therefore part of the configuration data. As a default, the ports are set to RS-232.

Table 5- 3 Pin assignment of the plug of the serial interface

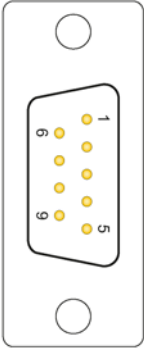
Illustration	Pin no.	Signal name	Signal direction	With TIM 4R-IE
	1	DCD	Input	
	2	RXD	Input	Switchover to RS-485 by configuration
	3	TXD	Output	Switchover to RS-485 by configuration
	4	DTR	Output	
	5	GND		
	6	-		
	7	RTS	Output	
	8	CTS	Input	
	9	-		

Ethernet interfaces

The Ethernet interfaces are designed as 8-pin RJ45 sockets.

Table 5- 4 Pin assignment of the RJ45 socket of the Ethernet interface

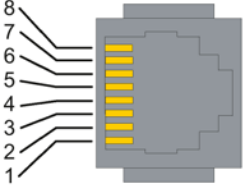
Illustration	Pin no.	Signal name	Signal direction
	1	TXD+	Output
	2	TXD-	Output
	3	RXD+	Input
	4	-	
	5	-	
	6	RXD-	Input
	7	-	
	8	-	

Certifications and approvals

Approvals issued

Note

Issued approvals on the type plate of the device

The specified approvals apply only when the corresponding mark is printed on the product. You can check which of the following approvals have been granted for your product by the markings on the type plate.

Approvals for shipbuilding are not printed on the device type plate.

Scope of validity of the approvals

The approvals listed below are only valid for the TIM module.

The products of the accessories program have their own approvals, that are not listed here.

EC declaration of conformity



The product meets the requirements and safety objectives of the following EC directives and it complies with the harmonized European standards (EN) for programmable logic controllers which are published in the official documentation of the European Union.

- **2014/34/EU (ATEX explosion protection directive)**

Directive of the European Parliament and the Council of 26 February 2014 on the approximation of the laws of the Member States concerning equipment and protective systems intended for use in potentially explosive atmospheres, official journal of the EU L96, 29/03/2014, pages. 309-356

- **2014/30/EU (EMC)**

EMC directive of the European Parliament and of the Council of February 26, 2014 on the approximation of the laws of the member states relating to electromagnetic compatibility.; official journal of the EU L96, 29/03/2014, pages. 79-106

- **2011/65/EU (RoHS)**

Directive of the European Parliament and of the Council of 8 June 2011 on the restriction of the use of certain hazardous substances in electrical and electronic equipment, official journal of the EC L174, 01/07/2011, page 88-110

The EC Declaration of Conformity is available for all responsible authorities at:

Siemens Aktiengesellschaft
 Division Process Industries and Drives
 Process Automation
 DE-76181 Karlsruhe
 Germany

You will find the EC Declaration of Conformity on the Internet at the following address:

Link: (<https://support.industry.siemens.com/cs/ww/en/ps/21771/cert>)

> Certificate type: "EC declaration of conformity"

IECEX

The product meets the requirements of explosion protection according to IECEx.

IECEX classification: Ex nA IIC T4 Gc

IECEX certificate: IECEx DEK 14.0086X

The product meets the requirements of the following standards:

- IEC 60079-0
Hazardous areas - Part 0: Equipment - General requirements
- EN 60079-15
Explosive atmospheres - Part 15: Equipment protection by type of protection 'n'

You can see the current versions of the standards in the IECEx certificate that you can find on the Internet at the following address:

Link: (<https://support.industry.siemens.com/cs/ww/en/ps/21771/cert>)

Note the conditions for the safe deployment of the product according to the section Notes on use in hazardous areas according to ATEX / IECEx (Page 87).

You should also note the information in the document "Use of subassemblies/modules in a Zone 2 Hazardous Area" that you can find on the Internet at the following address:

Link: (<https://support.industry.siemens.com/cs/ww/en/view/78381013>)

ATEX



The product meets the requirements of the EC directive:2014/34/EC "Equipment and Protective Devices for Use in Potentially Explosive Atmospheres".

ATEX approval: II 3 G Ex nA IIC T4 Gc

Type Examination Certificate: KEMA 03ATEX1228 X

Applied standards:

- EN 60079-0
Hazardous areas - Part 0: Equipment - General requirements
- EN 60079-15
Explosive atmospheres - Part 15: Equipment protection by type of protection 'n'

The current versions of the standards can be seen in the EC Declaration of Conformity, see above.

The conditions must be met for the safe deployment of the product according to the section Notes on use in hazardous areas according to ATEX / IECEx (Page 87).

You should also note the information in the document "Use of subassemblies/modules in a Zone 2 Hazardous Area" that you can find on the Internet at the following address:

Link: (<https://support.industry.siemens.com/cs/ww/en/view/78381013>)

EMC

The product meets the requirements of the EC Directive 2014/30/EU "Electromagnetic Compatibility" (EMC directive).

Applied standards:

- EN 61000-6-4
Electromagnetic compatibility (EMC) - Part 6-4: Generic standards - Emission standard for industrial environments
- EN 61000-6-2
Electromagnetic compatibility (EMC) - Part 6-2: Generic standards - Immunity for industrial environments

RoHS

The product meets the requirements of the EC directive 2011/65/EU on the restriction of the use of certain hazardous substances in electrical and electronic equipment.

Applied standard:

- EN 50581

c(UL)us



Applied standards:

- Underwriters Laboratories, Inc.: UL 61010-1 (Safety Requirements for Electrical Equipment for Measurement, Control, and Laboratory Use - Part 1: General Requirements)
- IEC/UL 61010-2-201 (Safety requirements for electrical equipment for measurement, control and laboratory use. Particular requirements for control equipment)
- Canadian Standards Association: CSA C22.2 No. 142 (Process Control Equipment)

Certificate Number: NRAQ7.E85972

cULus Hazardous (Classified) Locations



Underwriters Laboratories, Inc.: CULUS Listed E223122 IND. CONT. EQ. FOR HAZ. LOC.

Applied standards:

- ANSI ISA 12.12.01
- CSA C22.2 No. 213-M1987

APPROVED for Use in:

- Cl. 1, Div. 2, GP. A, B, C, D T4
- Cl. 1, Zone 2, GP. IIC T4

Ta: Refer to the temperature class on the type plate

Note the conditions for the safe deployment of the product according to the section Notes on use in hazardous areas according to UL HazLoc (Page 88).

Australia - RCM



The product meets the requirements of the AS/NZS 2064 standards (Class A).
Certificate Number: ABN 98 004 347 880

Marking for the customs union



EAC (Eurasian Conformity)
Customs union of Russia, Belarus and Kazakhstan
Declaration of the conformity according to the technical regulations of the customs union (TR CU)

KCC - For Korea only



Registration Number: KCC-REM-S49-TELECONTROL

A급 기기(업무용 방송통신기자재)

이 기기는 업무용(A급) 전자파 적합기기로서 판매자 또는 사용자는 이 점을 주의하시기
바라며, 가정 외의 지역에서 사용하는 것을 목적으로 합니다.

Current approvals

SIMATIC NET products are regularly submitted to the relevant authorities and approval centers for approvals relating to specific markets and applications.

If you require a list of the current approvals for individual devices, consult your Siemens contact or get the information on the Internet.

You can find the approvals for devices, including approvals for shipbuilding, on the Internet pages of the Siemens Industry Online Support:

- TIM 3V-IE
Link: (<https://support.industry.siemens.com/cs/ww/en/ps/15932/cert>)
- TIM 3V-IE Advanced
Link: (<https://support.industry.siemens.com/cs/ww/en/ps/15933/cert>)
- TIM 4R-IE
Link: (<https://support.industry.siemens.com/cs/ww/en/ps/15935/cert>)

Accessories

A.1 Router SCALANCE M

Routers for IP-based communication

To connect a communications module to IP-based infrastructure networks, the following routers are available:

- SCALANCE M812
ADSL router for wired IP communication via the Internet, VPN, firewall, NAT, 1 RJ-45 Ethernet interface, 1 digital input, 1 digital output, ADSL2T or ADSL2+
 - ADSL2T (analog phone connection - Annex A)
Article number: 6GK5812-1AA00-2AA2
 - ADSL2+ (ISDN connection - Annex B)
Article number: 6GK5812-1BA00-2AA2
- SCALANCE M816
ADSL router for wired IP communication via the Internet, VPN, firewall, NAT, 1 RJ-45 Ethernet interface with 4-port switch, 1 digital input, 1 digital output, ADSL2T or ADSL2+
 - ADSL2T (analog phone connection - Annex A)
Article number: 6GK5816-1AA00-2AA2
 - ADSL2+ (ISDN connection - Annex B)
Article number: 6GK5816-1BA00-2AA2
- SCALANCE M826-2
SHDSL router for IP communication via 2- and 4-wire cables, ITU-T standard G.991.2 / SHDSL.biz, SHDSL topology: Point-to point, bonding, line bridge mode; routing mode with VPN, firewall, NAT, 1 Ethernet interface with 4-port switch, 1 digital input, 1 digital output
Article number 6GK5826-2AB00-2AB2
- SCALANCE M874-2
2.5G router for wireless IP communication via 2.5G mobile phone, VPN, firewall, NAT, 1 RJ45 Ethernet interface with 2-port switch, SMA antenna connector, 1 digital input, 1 digital output
Article number: 6GK5874-2AA00-2AA2
- SCALANCE M874-3
3G router for wireless IP communication via 3G mobile phone HSPA+, VPN, firewall, NAT, 1 RJ45 Ethernet interface with 2-port switch, SMA antenna connector, 1 digital input, 1 digital output
Article number: 6GK5874-3AA00-2AA2

- SCALANCE M876-3
3G router for wireless IP communication via 3G mobile phone HSPA+/EV-DO, VPN, firewall, NAT, 1 RJ45 Ethernet interface with 4-port switch, SMA antenna connector, antenna diversity, 1 digital input, 1 digital output
Note network provider approvals!
 - International version
Article number: 6GK5876-3AA02-2BA2
 - Version for Korea
Article number: 6GK5876-3AA02-2EA2
- SCALANCE M876-4
4G router for wireless IP communication via LTE mobile phone, VPN, firewall, NAT, 1 RJ45 Ethernet interface with 4-port switch, 2 SMA antenna connectors, MIMO technology, 1 digital input, 1 digital output
 - Version for Europe
Article number: 6GK5876-4AA00-2BA2
 - Version for North America
Article number: 6GK5876-4AA00-2DA2

Information on the devices can be found on the Internet pages of Siemens Industry Online Support:

Link: (<https://support.industry.siemens.com/cs/ww/en/ps/15982>)

A.2 MODEM MD720

MODEM MD720

Article number: 6NH9720-3AA01-0XX0



Use in SIMATIC S7 stations that are part of a telecontrol or remote maintenance system and for communication with other stations in the network or an OPC server in the master station.

The MD720 supports the following types of communication:

- IP-based communication with the control center using GPRS and the MSC protocol or the MSCsec secure protocol
- SMS messages from or to a mobile telephone
- CSD communication for maintenance and for data connections

Technical specifications (excerpt)

Connection to Industrial Ethernet		
X1 interface	Number:	1
	Implementation:	D-sub 9-pin, female
	Characteristics:	RS-232 Control using AT commands
	Transmission speed:	19200 bps Permitted range: 300 ... 57600 bps
Wireless interface		
Antenna connector	Number:	1
	Implementation:	SMA socket
	Impedance:	50 Ω nominal
Frequency bands	GPRS / CSD:	Quad band: 850, 900, 1800, 1900 MHz
GPRS	Characteristics:	Maximum of 5 time slots at the same time, of which: <ul style="list-style-type: none"> • Up to 2 uplinks • Up to 4 downlinks
	Transmission speed <ul style="list-style-type: none"> • Uplink (modem → Internet) • Downlink (Internet → modem) 	Gross values: <ul style="list-style-type: none"> • Max. 42 kbps • Max. 54 kbps The net values (user data) are approximately 30% lower.
CSD	Characteristics:	MTC (Mobile Terminated Call)
	Transmission speed:	9600 bps
SMS (TX)	Characteristics:	Text mode

A.3 Mobile wireless antennas

GSM/GPRS antennas

The following antennas are available for use in GSM/GPRS networks and can be installed both indoors and outdoors. The antennas must be ordered separately.

Quadband antenna ANT794-4MR

You will find detailed information in the device manual. You will find this on the Internet on the pages of Siemens Industry Online Support:

Link: (<https://support.industry.siemens.com/cs/ww/en/view/23119005>)



Figure A-1 ANT794-4MR GSM/GPRS antenna

Short name	Article number	Explanation
ANT794-4MR	6NH9 860-1AA00	Quadband antenna (900, 1800/1900 MHz, UMTS); weatherproof for indoor and outdoor areas; 5 m connecting cable connected permanently to the antenna; SMA connector, including installation bracket, screws, wall plugs

Flat antenna ANT794-3M



Figure A-2 Flat antenna ANT794-3M

Short name	Article number	Explanation
ANT794-3M	6NH9 870-1AA00	Flat antenna (900, 1800/1900 MHz); weatherproof for indoor and outdoor areas; 1.2 m connecting cable connected permanently to the antenna; SMA connector, including adhesive pad, screws mounting possible

You will find detailed information in the device manual. You will find this on the Internet on the pages of Siemens Industry Online Support:

Link: (<https://support.industry.siemens.com/cs/ww/en/view/48729835>)

A.4 Dedicated line and dialup network modems

Modems for dedicated line and dialup networks

Note

Discontinuation of modules

The following products have the product status "type discontinued" but if they exist can be operated with the communications module:

- Modem MD2
Dedicated line modems
Product notification on the Internet:
Link: (<https://support.industry.siemens.com/cs/ww/en/view/109740149>)
- Modem MD3
Modems for analog dialup networks
Product notification on the Internet:
Link: (<https://support.industry.siemens.com/cs/ww/en/view/109740148>)
- Modem MD4
Modems for ISDN networks
Product notification on the Internet:
Link: (<https://support.industry.siemens.com/cs/ww/en/view/67637816>)

When using the serial interface for dedicated line and dialup networks, use suitable products of other vendors.

A.5 Connecting cables

A series of standard connecting cables is available to connect individual SINAUT components with each other and to WANs. The following connecting cables can be ordered as required.

Table A- 1 Standard cables for connecting TIM and modem modules

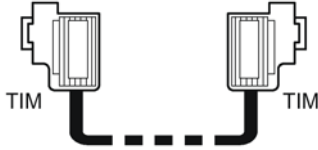
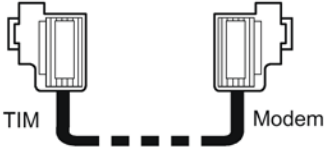
Order no.	Description	Illustration
6NH7701-0AR	Test cable. Cable for connecting two TIMs via their RS-232 interface without modems (null modem). Cable length 6 m	 The diagram shows two TIM modules connected by a dashed line representing a cable. Each module has a connector with a central pin and two side pins. The modules are labeled 'TIM'.
6NH7701-4AL	Cable for connecting a TIM (RS-232) to a SINAUT ST7 MDx modem (RS-232). Cable length 1.5 m	 The diagram shows a TIM module on the left and a Modem module on the right, connected by a dashed line representing a cable. Both modules have the same connector type as in the previous diagram. The modules are labeled 'TIM' and 'Modem'.

A.5 Connecting cables

Order no.	Description	Illustration
6NH7701-4BN	Cable with one end without connector for connection of a TIM to a third-party modem or wireless device (RS-232). Cable length 2.5 m	
6NH7701-5AN	Cable for connecting a TIM (RS-232) with the GSM mobile wireless modem MODEM MD720 (RS-232). Also suitable for third-party modems or wireless devices with standard RS-232. Cable length 2.5 m.	

The following figures show the assembly of the connecting cables.

6NH7701-0AR

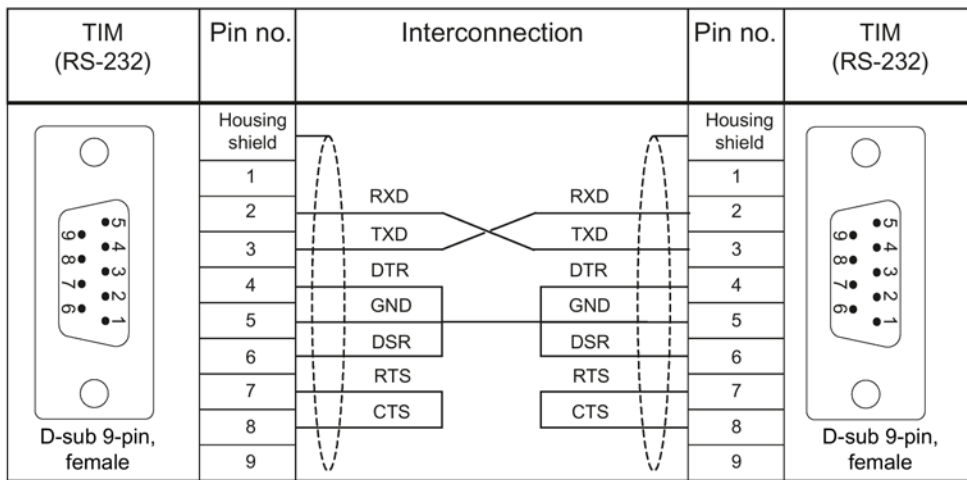

Figure A-3 Assembly of the standard connecting cable 6NH7701-0AR

6NH7701-4AL

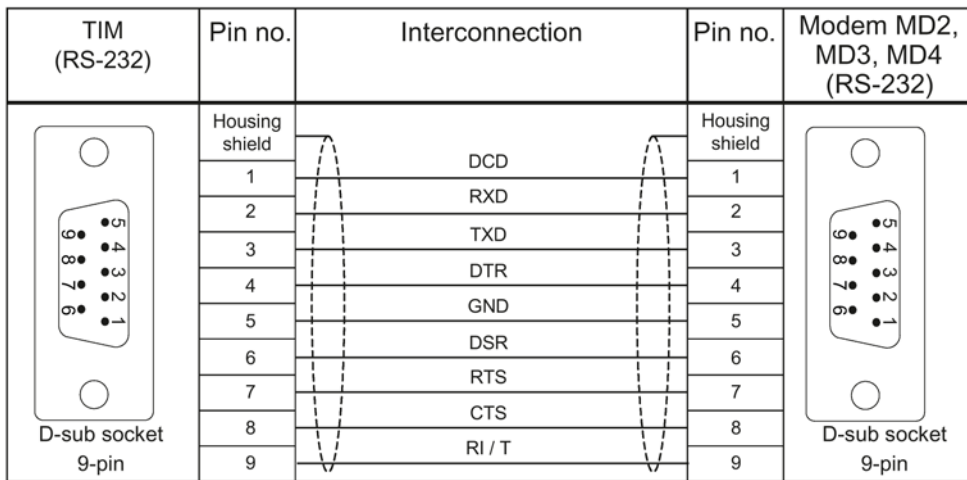

Figure A-4 Assembly of the standard connecting cable 6NH7701-4AL

6NH7701-4BN

TIM (RS-232)	Pin no.	Interconnection	Pin no.	Open cable end
 <p>D-sub socket 9-pin</p>	Housing shield		Housing shield	
	1	DCD	1	white
	2	RXD	2	brown
	3	TXD	3	green
	4	DTR	4	yellow
	5	GND	5	gray
	6	DSR	6	pink
	7	RTS	7	blue
	8	CTS	8	red
	9	RI / T	9	black

Figure A-5 Assembly of the standard connecting cable 6NH7701-4BN

6NH7701-5AN

TIM (RS-232)	Pin no.	Interconnection	Pin no.	MODEM MD720 (RS-232)
 <p>D-sub socket 9-pin</p>	Housing shield		Housing shield	 <p>D-sub socket 9-pin</p>
	1	DCD	1	
	2	RXD	2	
	3	TXD	3	
	4	DTR	4	
	5	GND	5	
	6	DSR	6	
	7	RTS	7	
	8	CTS	8	
	9	RI / T	9	

Figure A-6 Assembly of the standard connecting cable 6NH7701-5AN

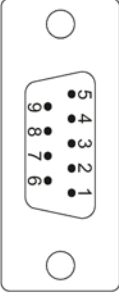
A.6 Cable for RS-485 connection

Accessories for RS-485 operation of the serial interface

Excerpt from the Siemens accessories program PROFIBUS or RS-485 operation

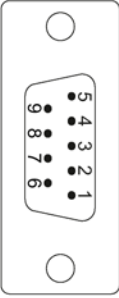
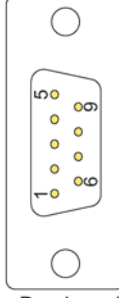
- **Cable**
 - PROFIBUS FC standard cable GP, bus cable 2-wire, shielded, special design for fast installation, sold by the meter
02YSY (ST) CY, 1x2x0.64 / 2.55-150 VI KF 40 FR
Article number: 6XV1830-0EH10

- **Terminating resistor**

In a network in RS-485 operation the terminating resistor of the bus cable is turned on or off by the STEP 7 configuration.

The connecting cable for the serial interface in RS-485 operation must be assigned as follows:

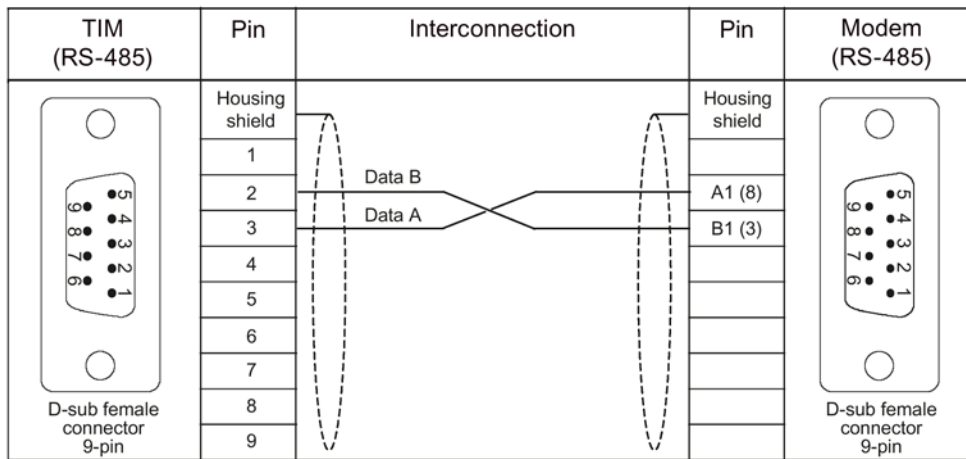

Figure A-7 Assignment of the cable for the RS-485 interface

A.7 Ethernet cables

Connecting cables for connecting to Ethernet

There is no standard connecting cable available in the SINAUT range to connect the TIM to Ethernet. Use the suitable Ethernet connecting cables (for example IE TP Cord) from the SIMATIC NET product range (catalog IK PI).

The cable must be suitable for the 10Base-TX or 100Base-TX specification.

If the TIM is connected to a switch or router, it is advisable to use fully shielded straight-through patch cables with RJ45 connectors at both ends and 1:1 pin assignment.

Two TIMs can also be connected over Ethernet using a crossover patch cable with RJ45 connectors at both ends and the following pin assignment:

Pin no. / Signal	Interconnection	Pin no. / Signal
TXD (+) 1		1 TXD (+)
TXD (-) 2		2 TXD (-)
RXD (+) 3		3 RXD (+)
4		4
5		5
RXD (-) 6		6 RXD (-)
7		7
8		8

Figure A-8 Pinout of a crossover Ethernet RJ-45 cable

A.8 C-PLUG

The TIM 4R-IE can be operated with a C-PLUG. A C-PLUG does not ship with the TIM.

The following C-PLUGs are available:

- **C-PLUG 32**

Article number: 6GK1 900-0AB00

Memory:

- Total capacity: 32 MB
- Free capacity available: 30 MB

Number of write cycles: Max. approx. 100000

- **C-PLUG 256**

Article number: 6GK1 900-0AB01

Memory:

- Total capacity: 256 MB
- Free capacity available: 126 MB

Number of write cycles: Max. approx. 200000

Recommendation: Avoid writing data cyclically. The flash area allows a limited number of write cycles.

You can find additional details in the Siemens Industry Mall:

Link: (<https://mall.industry.siemens.com>)

References

Where to find Siemens documentation

- Article numbers

You will find the article numbers for the Siemens products of relevance here in the following catalogs:

- SIMATIC NET - Industrial Communication / Industrial Identification, catalog IK PI
- SIMATIC - Products for Totally Integrated Automation and Micro Automation, catalog ST 70

You can request the catalogs and additional information from your Siemens representative. You will also find the product information in the Siemens Industry Mall at the following address:

Link: (<https://mall.industry.siemens.com>)

- Manuals on the Internet

You will find SIMATIC NET manuals on the Internet pages of Siemens Industry Online Support:

Link: (<https://support.industry.siemens.com/cs/ww/en/ps/15247/man>)

Go to the required product in the product tree and make the following settings:

Entry type "Manuals"

- Manuals on the data medium

You will find manuals of SIMATIC NET products on the data medium that ships with many of the SIMATIC NET products.

/1/

SIMATIC NET
SINAUT ST7
System Manual
- Volume 1: Station control system
- Band 2: Software (STEP 7 V5)
- Volume 3: Software (STEP 7 Professional)
Siemens AG
Link: (<https://support.industry.siemens.com/cs/ww/en/ps/21771/man>)

/2/

/2/

SIMATIC S7
S7-300 Automation System
Siemens AG

- CPU 31xC and 31x Installation: Operating instructions
Link: (<https://support.industry.siemens.com/cs/ww/en/view/13008499>)
- Module Data: Reference manual
Link: (<https://support.industry.siemens.com/cs/ww/en/view/8859629>)

/3/

SIMATIC NET
MODEM MD720
Operating Instructions
Siemens AG
Link: (<https://support.industry.siemens.com/cs/ww/en/ps/15923/man>)

/4/

SIMATIC NET
Mobilfunkrouter SCALANCE M870
(M873 / M874 / M875 / M876)
Operating Instructions
Siemens AG
Link: (<https://support.industry.siemens.com/cs/ww/en/ps/15987/man>)

/5/

SIMATIC NET
SINAUT ST7cc
manual
Siemens AG
Link: (<https://support.industry.siemens.com/cs/ww/en/ps/15927/man>)

/6/

SIMATIC NET
SINAUT ST7sc
manual
Siemens AG
Link: (<https://support.industry.siemens.com/cs/ww/en/ps/15929/man>)

/7/

SIMATIC NET
Industrial Ethernet Security
Security basics and applications
Configuration manual
Siemens AG
Link: (<https://support.industry.siemens.com/cs/ww/en/ps/15326/man>)

/8/

SIMATIC NET
Industrial Ethernet Security
SCALANCE S
Commissioning and Installation Manual
Siemens AG
Link: (<https://support.industry.siemens.com/cs/ww/en/ps/15327/man>)

/9/

SIMATIC NET
TIM 1531 IRC
Operating instructions
Siemens AG
Link: (<https://support.industry.siemens.com/cs/ww/en/ps/24710/man>)

/10/

SIMATIC NET
CP 1243-8
Operating Instructions
Siemens AG
Link: (<https://support.industry.siemens.com/cs/ww/en/ps/21162/man>)

/11/

SIMATIC
CP 1542SP-1 IRC
Operating Instructions
Siemens AG
Link: (<https://support.industry.siemens.com/cs/ww/en/ps/22143/man>)

/12/

SIMATIC
RTU3000C
Operating instructions
Siemens AG
Link: (<https://support.industry.siemens.com/cs/ww/en/ps/21767/man>)

Glossary

1-out-of-8 check

Mechanism for interlocking multiple simultaneous commands.

When entering commands, there is a check to determine if only one command is pending at the time of acquisition. Transmission of the command byte is only triggered if there is a single modified command bit in the command byte compared to the last cycle. If several bits within the command byte have been changed, errors are detected and the command byte is not sent.

The function is performed by the data point typical "Cmd01B_S" of the TD7onCPU block library. The "FC Safe" block is also required.

1-out-of-n check

Mechanism for interlocking multiple simultaneous commands.

When entering commands, there is a check to determine if only one command is pending at the time of acquisition. Transmission of the command to the communication partner is only triggered when a single command is pending. If several commands are pending at the same time, errors are detected and the command is not sent or not issued by the receiver.

The function is executed by the "FC Safe" block of the TD7onCPU block library. The function is supported by the data point typicals "Cmd01B_S", "Par12D_S" and "Set01W_S".

APN

Access Point Name

DNS host name of the access point for an external network (in this case: access point in the GPRS network to the Internet).

Conditional spontaneous frame

→ *Spontaneous / conditional spontaneous / unconditional spontaneous frame*

CP

Communications processor

Module for expanded communications tasks that provides the CPU with additional interface types or communications options.

CPU

Central Processing Unit

Main processor of a SIMATIC controller

CSD

Circuit Switched Data

Service for transferring data in the GSM network. Possible are dial-in connections of GSM modems to GSM/ISDN/analog modems and other devices with modems. The transmission speed is 14400 bps full duplex for non-secure transmission and 9600 bps for secure transmission.

CTS

Clear to send

Signal in the data flow control

Data frame

Data unit transferred between communication partners. Meaning:

- Data unit transferred on the application layer (OSI layer 7)
- General term for a transferred data unit regardless of the relevant OSI layer.

Data frames contain the data of an ST7 object to be transmitted. Depending on the object type, a message can contain either all data of an ST7 object or a contiguous subarea of the object data.

See also "Organizational frame"

Direct communication

With direct communication, the S7 stations communicate directly with each other without the frames needing to be forwarded by a master station or station.

See also "Inter-station communication"

Context: Telecontrol / SINAUT

DNP

Distributed Network Protocol

DNP3 TIM

→ *TIM*

DSL

Digital Subscriber Line

Standards for transmission of telephone and Internet data with transmission speeds up to 1000 Mbps.

EGPRS

Enhanced GPRS

Packet-oriented service for IP-based data transmission in GSM networks. By using an additional modulation procedure (EDGE technology), a higher transmission speed is achieved compared with GPRS.

Engineering station

PC with the STEP 7 Professional project (TIA Portal)

Ethernet TIM

→ *TIM*

Frame

→ *Data frame*

General request

With a general request (GR), a central station requests the current process image from the connected nodes.

A general request is started automatically when a disrupted connection has been restored or when a failed partner reports a restart. Apart from the automatic general request, a general request can also be triggered by the user program or from the control center.

TD7onTIM does not support general requests.

GPRS

General Packet Radio Service

Packet-oriented service for IP-based data transmission in GSM networks. The data is transmitted using the Internet protocols TCP/IP or UDP/IP.

GSM

Global System for Mobile Communication

Worldwide standard for mobile communication (2G)

Image memory

Memory area for the process image in a telecontrol module

Each data frame is saved exactly one time in the image memory. New values of a data point overwrite the existing value in the image memory.

See also send buffer

Context: TeleControl

Image memory / send buffer principle

- **Image memory principle**

A fixed position is reserved in the image memory for each data message transferred to the TIM for transmission. Each newly transferred message always overwrites the old message in the image memory.

If a send message is entered using the image memory principle, only a reference to the location of the message in the message image memory is entered. If the TIM has not yet been able to transmit the message when the same message is transferred to it again, the message is not entered in the send buffer a second time, but rather the image is simply updated.

At the time of transmission, the message is sent with its up-to-date content from the image memory. Only then can the message be entered in the send buffer again.

Transmission using the image memory principle achieves the following:

- There is less load on transmission link, fewer messages are transmitted.
- There is less load on the send buffer of the TIM; an image memory message is entered a maximum of once in the send buffer.

- **Send buffer principle**

If a data frame is transmitted using the send buffer principle, it is entered completely in the send buffer each time it is transferred to the TIM. If such a message cannot or should not be transmitted immediately, it may exist more than once in the send buffer.

When it is sent, the message is taken completely from the send buffer and transmitted.

Inter-station communication

Communication between two stations, which is mediated by a Telecontrol/SINAUT master station.

For dial-up networks, a direct connection between the two stations is established in ST7 networks.

See also "Direct communication".

IRC

Industrial Remote Communication

SIMATIC NET product group for telecontrol.

ISDN

Integrated Services Digital Network

Standard for a digital transmission network for telephone, telefax, telex, teletext and datex-J/L/P services. The data of various services can be transferred simultaneously. Telephone connections normally operate at transmission speeds of 56 to 64 Kbps.

LAN

Local Area Network
Local network, usually "Industrial Ethernet".

Local CPU

CPU which is assigned to a TIM module.

Local TIM

A TIM connected to a PC (ST7cc, ST7sc) or an S7 CPU over the MPI bus, Industrial Ethernet or an IP-based network.

LTOP

Line Transformer with Overvoltage Protection
Overvoltage protection module of the SINAUT device program - discontinued

Main cycle / sub-cycle

The sequence of the polling cycle can be structured on the master TIM by assigning individual polling stations to the main cycle or the subcycle.

The subcycle is always activated at the end of the main cycle once all stations from the main cycle have been polled. A configurable number of stations is called in a subcycle.

Following this, all the stations in the main cycle are polled again. This is followed by a subcycle in which further stations that are assigned to the subcycle are called.

Master station

Station in the top hierarchy of a telecontrol network with ST7 protocol. It is connected to the control system and the substations or node stations.

The WAN interfaces of the TIM are set to the network node type "Master station".

MCC - Mobile Country Code

→ *PLMN*

Messages

Emails and SMS in the TeleControl context

See also Data frame.

MNC - Mobile Network Code

→ *PLMN*

MPI

Multi Point Interface

MPI is the programming device interface of the SIMATIC S7-300/400. Devices such as the TIM can communicate with each other via the MPI interface.

See also Partyline.

MSC

The MSC transmission protocol is a proprietary protocol on OSI layer 3 for the secure communication via Ethernet, landline or mobile wireless networks in SINAUT ST7. The MSC protocol provides an authentication mechanism and simple encryption of data.

The protocol is available in the MSC and MSCsec versions (with cyclic key exchange).

MSCsec

→ *MSC*

Multi-master polling with time slots

When stations need to communicate with more than one master station in dedicated line or wireless operation, the multimaster polling with time slots mode is used. Each of the connected master stations is assigned one or more defined time slots per minute for polling the stations. The master stations then have their turn to poll in every minute.

Node station

A node station is a station located between the master station and stations in the hierarchy of a telecontrol network. One or more subordinate stations are connected to a node station. The data traffic between these stations and the master station is handled via the node station. Direct data exchange between the node station and the subordinate stations is also possible. Multiple node station levels are possible in a SINAUT network.

Organizational frame

Organizational frames are used to execute organizational system functions, for example:

- General requests
- Time-of-day synchronization
- Counted value storage
- Coordinated connection establishment and termination in a dial-up network
- Message indicating station startup and station failure
- Requests for and transmission of subscriber records

Party line

Setup of the communications bus of the smaller S7-300 CPUs. The communications bus is physically wired through to the MPI interface.

Party line CPUs are: CPU 312.. / 313.. / 314.. / 315.. to CPU 315-2 DP and C7 devices.

With party line CPUs you can use every type of TIM. You will find details on the Internet at the following address:

<https://support.industry.siemens.com/cs/ww/en/view/24059469>

With non party line CPUs (CPU 315-2 PN/DP to CPU 319-3 PN/DP) the MPI interface and communications bus are separate.

Permanent call

A permanent call does not interrupt the normal polling cycle; it is always executed alternating with the standard poll from the normal polling cycle.

PG

Programming device

Allows access by the STEP 7 configuration software to the SIMATIC CPU.

PG routing

Using PG routing, it is possible to access programmable modules or modules with diagnostics capability beyond network boundaries from a programming device (PG) or computer (PC).

PLMN

Public Land Mobile Network

Worldwide unique identifier of mobile networks. The PLMN is made up of the three-digit Mobile Country Code (MCC) and the two-or three-digit Mobile Network Code (MNC) of the network provider.

Polling

→ *Polling mode*

Polling mode

The polling mode is a method of data transmission in which a central instance controls the data exchange with the communication partners.

Using a polling message, the master TIM instructs the connected station TIMs one after the other to transmit their stored data frames to the master TIM. If a polled station has no stored data, it responds with an acknowledgment message and the polling cycle then continues by polling the next station.

A station that has stored data sends a single data frame or, if block transfer was configured, several data frames in a block.

If the TIM has stored additional data, it indicates this in the response frame. In this case, the station is then immediately called up again until the stored data has been transferred.

Polling with time slots

The polling with time slots mode is used in a wireless network in which the use of the radio frequency assigned by the registration authorities must be shared with other users. Each user typically has 6 seconds per minute to exchange data with its stations. The frequency must then be released for other operators. During the allocated time slot, this pooling variant functions like a normal polling system.

Context: SINAUT ST7

Protocol

A protocol is a set of rules for controlled transfer of data. Protocols, for example, specify the data structure, the structure of data packets and the coding. Protocols can also specify a control mechanisms and hardware and software requirements.

Requested message

Polled data frames are data frames of a station or node TIM with a special identifier indicating that they were sent in response to a general request from the master station.

RS-232

RS-232 is a standard for serial (bit-by bit) data transmission with +12 V and -12 V signals. RS-232 is a Recommended Standard of the Electronic Industries Association. 9-pin and 25-pin connections with D-sub connectors (subminiature connector with D-shaped surface area) are normal for the RS-232 interface.

RS-485

RS-485 is a standard for data transmission with 5 V differential signals. The RS-485 interface uses only one pair of wires and is operated in half duplex. The connection is multipoint-compliant; in other words, up to 32 subscribers can be connected.

RTS

Request to send

Signal in the data flow control

S0 interface

Basic interface of ISDN for connecting end devices

Send buffer principle

→ *Image memory / send buffer principle*

SIM card

SIM - Subscriber Identity Module

The SIM card is an identification card for a subscriber of a mobile wireless service.

Simple Internet communication

In SINAUT ST7, simple Internet communication means data exchange between TCP/IP-compliant devices in Ethernet, landline or mobile networks using the MSC protocol.

SINAUT

Siemens Network Automation

Station control system or telecontrol system based on SIMATIC S7.

SINAUT ST7 works with the SINAUT ST7 telecontrol protocol.

SINAUT object

A SINAUT object contains the data of one or more process variables such as analog values, commands, calculated values, status information on motors, sliders etc. An ST7 object has type-specific processing functions and change checks assigned to it to minimize the communication traffic in the WAN. Type-specific processing functions include, for example, threshold checks or mean value calculation with the object type for analog values. The change check is designed so that a message is generated only when the object data has changed compared with the last time its value was transferred.

SINAUT ST7

Proprietary telecontrol protocol for SIMATIC NET telecontrol modules

SINAUT ST7cc

Control center system based on SIMATIC WinCC for SINAUT ST7.

SINAUT ST7sc

System for networking SIMATIC stations with a control station via WAN. The control center can also be a SIMATIC station or a PC-based control center, for example, WinCC with the SINAUT ST7cc add-on.

SINAUT TD7 Library

Software for control of ST7 communication of telecontrol modules. The TD7 software in the stations allows change-controlled transmission of process data between the individual CPUs and the control center, for example ST7cc. Failure of connections, CPUs, or the control center are displayed. Once a problem has been corrected or the CPUs or control center have started up, data is updated automatically. Data frames can be given a time stamp, if required.

The following variants of the TD7 software exist:

- **TD7onCPU**

Program blocks in the CPU user program

The SINAUT TD7 library consists of program blocks for the CPU. They are available in the following versions:

- Library for STEP 7 V5

The blocks are executable on S7-300- and S7-400-CPU's (except CPU 400H). There are only a few blocks intended specifically for the S7-300 or S7-400.

- Libraries for STEP 7 Professional

There is a global library with two versions for STEP 7 projects in the TIA Portal:

- Blocks for S7-1500
- Blocks for S7-300 and S7-400

If the DNP3 protocol is used, TD7onCPU is not supported.

- **TD7onTIM**

Configurable part of the firmware of the communication module

TD7onTIM can be used as an alternative to TD7onCPU for an Ethernet TIM. TD7onTIM runs on the TIM. It is configured as follows:

- STEP 7 V5: In the SINAUT engineering software
- STEP 7 Professional: Via data points of the TIM

TD7onCPU and TD7onTIM cannot be used simultaneously in a station.

SMS

Short Message Service

The short message service in the GSM standard is used to transfer short text messages to mobile phone users.

When the short messages are transferred, they are first transferred to the SMS center (SMSC) using a store-and-forward technique. They are buffered there and then forwarded to the recipient. The sender can query the status of the message in the SMS center or can request acknowledgment of delivery.

SMSC

Short Message Service Center

When sending an SMS message, the message is first sent to the SMSC, buffered there and then forwarded to the recipient.

Spontaneous / conditional spontaneous / unconditional spontaneous frame

- **Spontaneous frame**

In SINAUT networks, data frames are always transmitted spontaneously; in other words, data are created and transmitted only when changes to process values occur or event-controlled. These messages are known as spontaneous messages.

- **Conditional spontaneous frame**

In the dial-up network, you can specify whether or not a change causes a "conditional spontaneous" or "unconditional spontaneous" transmission for each individual message.

Conditional spontaneous messages are initially only entered in the send buffer of the TIM. They are only transmitted when a connection is established to the partner for whatever reason, for example because an unconditional spontaneous message needs to be transmitted or because the partner calls.

Even when using pay by volume transmission in a GPRS network, message prioritization "conditional spontaneous" can also be used. Such a message is not transmitted immediately, but is first buffered. In a GPRS network, the TIM stores "conditional spontaneous" messages in the following situations:

- When the collected frames reach or exceed a size of 202 bytes.
- An important frame ("unconditional spontaneous" or "spontaneous" priority) should be transmitted immediately.
- The collected frames have not yet reached a volume of 202 bytes, but the TCP/IP keep-alive interval expires.
- The fill level of the send buffer has reached 90% of its maximum capacity.

- **Unconditional spontaneous frame**

In the dial-up network, you can specify whether or not a change causes an "conditional spontaneous" or "unconditional spontaneous" transmission for each individual message.

Unconditional spontaneous messages cause the connection to be established immediately. Even with pay-by-volume/time transmission in a GPRS network, you can use the message prioritization "unconditional spontaneous"; in other words, in contrast to a "conditional spontaneous" message, a message is transmitted immediately.

Spontaneous mode

The spontaneous mode is a method of SINAUT data transmission in which subscribers can exchange data among themselves directly. Here, no central entity is necessary in the form of a master TIM as in polling mode (see "Polling mode"). The spontaneous mode is intended for data transmission in dial-up networks and for communication via IP-based networks.

For transmission in a dial-up network and in pay-by-volume/time IP-based networks (for example GPRS), the data to be sent is assigned different priorities during parameter assignment ("high" or "normal", with TD7onTIM also "alarm"). When data with high or alarm priority are ready for transmission, the dial-up connection is established immediately. If the data has "normal" priority, it is first stored on the TIM. This data is then sent the next time a

connection is established to the partner for whatever reason. This can, for example, be the situation when information with higher priority needs to be sent or when the partner establishes a connection to exchange data.

ST7 protocol

→ *SINAUT ST7*

ST7cc

→ *SINAUT ST7cc*

ST7sc

→ *SINAUT ST7sc*

ST7-TIM:

→ *TIM*

Station

- Hardware
SIMATIC controller with the required components for acquisition, processing and communication, consisting of: CPU, I/O modules, communication module, modem, etc.
- Network node type
Setting a WAN interface of the TIM. An interface of the "Station" network node type communicates at the lowest hierarchy level in a SINAUT network.

Subcycle

→ *Main cycle / sub-cycle*

TD7 software

→ *SINAUT TD7 Library*

TIM

Telecontrol Interface Module

Communication module that handles all data transmission functions provided by the SINAUT system independently.

- Ethernet TIM

Compared to a classic TIM, an Ethernet TIM (ST7-TIM) has additional LAN interfaces for IP-based communication.
- ST7-TIM:

An ST7-TIM uses the SINAUT ST7 telecontrol protocol.

 - The TIM 3V-IE versions have an RS-232 and an Ethernet interface.
 - The TIM 4R-IE has two RS-232 / RS-485 and two Ethernet interfaces.
 - The TIM 1531 IRC has two RS-232 / RS-485 and two Ethernet interfaces.
- DNP3 TIM

A DNP3 TIM uses the DNP3 telecontrol protocol.

 - TIM 3V-IE DNP3 has an RS-232 interface and an Ethernet interface.
 - TIM 4R-IE DNP3 has four WAN connections: Two RS-232/RS-485 interfaces and two Ethernet interfaces

Unconditional spontaneous frame

→ *Spontaneous / conditional spontaneous / unconditional spontaneous frame*

VPN

Virtual Private Network

Technology for secure transportation of confidential data in public IP networks, for example the Internet.

WAN

Wide Area Network

Data network with a large geographical span, such as the Internet. telephone or enterprise networks. The following WANs can be used with SINAUT:

- **WAN, classic**

Includes SINAUT communication via dedicated lines (private or leased), private wireless networks, analog telephone network, digital ISDN network and mobile networks (without Internet).

A classic WAN is connected via suitable transmission device (modem) to a serial interface of the TIM.
- **WAN, IP-based**

Includes IP-based telecontrol communication via wireless, fiber-optic cables, public networks and the Internet using services such as DSL, GPRS or UMTS or via broadband systems such as OTN and PCM30.

An IP-based WAN is normally connected to an RJ-45 interface of an Ethernet TIM via an Ethernet-compliant module.

Index

A

Abbreviations/acronyms, 5
Authentication, 34

B

Button, 48

C

Cross references (PDF), 6
Current consumption, 112

D

Default startup, 49
Default startup, automatic (TIM 4R-IE), 100
Direct communication, 33
Disposal, 9

E

E-mail, 33
Encryption, 34

F

Firewall, 35
Firmwareversions, 3

G

Glossary, 9

I

Inter-station communication, 33
IPsec, 35

M

MSC, 34

MSCsec, 34

P

Power loss, 112
Product name, 5

R

Recycling, 9
Replacing a device, 96
Requirements - software, 6
Reset, 48
RS-485
 Cable, 126
 Connecting up, 93, 94

S

Safety notices, 85
Security
 Protocols, 34
Service & Support, 9
SIMATIC NET glossary, 9
SMS, 33
Software - requirements, 6
Software - versions, 3
Spare parts, 20
STEP 7 - version, 6
STEP 7 versions, 3

T

Terminating resistor, 93, 94
Training, 9

V

VPN, 35

