

Self Diagnosis
Supported model

SERVICE MANUAL

WA1 CHASSIS

MODEL

COMMANDER

DEST

KLV-27HR3

RM-Y1108

AEP



KLV-27HR3



RM-Y1108

FLAT PANEL COLOR TV
SONY®

If you need more information on Computer and Electronic Repair, please visit these websites to improve yourself.

<http://www.fastrepairguide.com>

<http://www.protech2u.com>

<http://www.plasma-television-repair.com>

<http://www.lcd-television-repair.com>

Happy Repairing!!

Highly Recommended Repair Ebook:

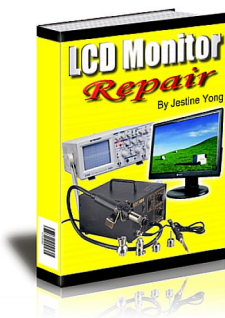

If you're a LCD Monitor repairer, then this is the best guide for you. Why? Because, the author revealed all his LCD Monitor Repairing secrets for you. I think, with just few Repair tips you learned from this guide you will get back your investment!

[Click Here to read](#) more.



This eBook will show you how to test the electronic component correctly and accurately. Some of you may say that I don't need this eBook because it is too simple! Do you know that, in fact there is lots of testing electronic components secrets I have learned from this guide? Do you know how to test a 'TRIAC' correctly and accurately? If you answer no then I guess you have to get this eBook. [Click Here to read more.](#)

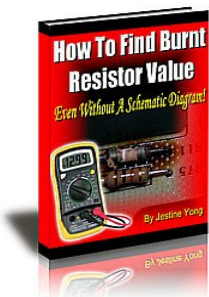

Are you tired of searching the service manuals to look for the value of a burnt resistor? If the answer is YES, then this eBook is a 'must have' guide for you. You can save a lot of time and be able to repair customer's Electronic equipment with burnt resistors in it.

[Click here to read more.](#)

TABLE OF CONTENTS

Section	Title	Page	Section	Title	Page
	Caution	3	4. DIAGRAMS		
	Specifications	4	4-1.	Block Diagrams (1)	25
	Connectors	5		Block Diagrams (2)	26
	Self Diagnosis	6	4-2.	Circuit Board Location	26
1. GENERAL		7	4-3.	Schematic Diagrams and Printed Wiring Boards	26
2. DISASSEMBLY				A Board Schematic Diagram	27
2-1.	Rear Cabinet Assembly Removal	18		A Board Printed Wiring Board	30
2-2.	Rear Cover Removal	18		G2 Board Schematic Diagram	32
2-3.	A Board Removal	19		G2 Board Printed Wiring Board	33
2-4.	G2 Board Removal	19		H1 Board Schematic Diagram	35
2-5.	H1 Board Removal	20		H1 Board Printed Wiring Board	36
2-6.	H2 Board Removal	20		H2 Board Schematic Diagram	35
2-7.	H3 Board Removal	21		H2 Board Printed Wiring Board	36
2-8.	H5 Board Removal	21		H3 Board Schematic Diagram	37
2-9.	LCD Bracket Removal	22		H3 Board Printed Wiring Board	36
2-10.	LCD Assembly Removal	22		H5 Board Schematic Diagram	35
				H5 Board Printed Wiring Board	36
3. SET-UP ADJUSTMENTS			4-4.	Semiconductors	38
3-1.	Signal Adjustment	23	5. EXPLODED VIEWS		
3-1-1.	Pal auto adjustment (CVBS)	23	5-1.	Front Cabinet Assy	40
3-1-2.	Pal auto adjustment (RGB)	23	5-2.	Rear Cover, Rear Cabinet Assy, Stand Assy and Chassis	41
3-1-3.	Secam auto adjustment (CVBS)	23	6. ELECTRICAL PARTS LIST		42
3-2.	White Balance Adjustment	23			
3-2-1.	White Balance adjustment (H/L)	23			
3-2-2.	White Balance adjustment (C/O)	24			
3-2-3.	Secam White Balance adjustment (C/O)	24			
3-3.	Test Test Mode	24			

WARNING !!

AN ISOLATION TRANSFORMER SHOULD BE USED DURING ANY SERVICE WORK TO AVOID POSSIBLE SHOCK HAZARD DUE TO LIVE CHASSIS, THE CHASSIS OF THIS RECEIVER IS DIRECTLY CONNECTED TO THE POWER LINE.

SAFETY-RELATED COMPONENT WARNING !!

COMPONENTS IDENTIFIED BY SHADING AND MARKED Δ ON THE SCHEMATIC DIAGRAMS, EXPLODED VIEWS AND IN THE PARTS LIST ARE CRITICAL FOR SAFE OPERATION. REPLACE THESE COMPONENTS WITH SONY PARTS WHOSE PART NUMBERS APPEAR AS SHOWN IN THIS MANUAL OR IN SUPPLEMENTS PUBLISHED BY SONY.

CAUTION

Lead Free Soldered Boards

The circuit boards listed below [Table 1] used in these models may have been processed using Lead Free Solder. The boards are identified by the LF logo located close to the board designation e.g. F1, H1 etc [see examples]. The servicing of these boards requires special precautions to be taken as outlined below.



example 1

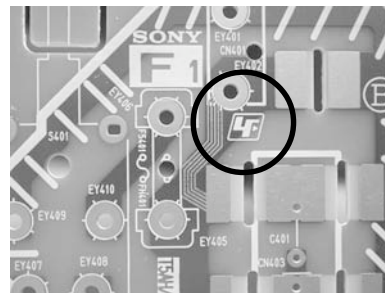

example 2



Table 1

Board	Function
A	Tuner, Audio, Chroma Decoder, Scart 1
G2	Power Supply
H1	Control Buttons
H2	Front Input, HP Output
H3	Scart 2
H5	IR Receiver & LED's

It is strongly recommended to use Lead Free Solder material in order to guarantee optimal quality of new solder joints. Lead Free Solder is available under the following part numbers :

Partnumber	Diameter	Remarks
7-640-005-19	0.3mm	0.25Kg
7-640-005-20	0.4mm	0.50Kg
7-640-005-21	0.5mm	0.50Kg
7-640-005-22	0.6mm	0.25Kg
7-640-005-23	0.8mm	1.00Kg
7-640-005-24	1.0mm	1.00Kg
7-640-005-25	1.2mm	1.00Kg
7-640-005-26	1.6mm	1.00Kg

Due to the higher melting point of Lead Free Solder the soldering iron tip temperature needs to be set to 370 degrees centigrade. This requires soldering equipment capable of accurate temperature control coupled with a good heat recovery characteristics.

For more information on the use of Lead Free Solder, please refer to <http://www.sony-training.com>

ITEM MODEL	Television System	Stereo System	Channel Coverage	Color System
AEP	B/G/H, D/K, I, L	GERMAN/NICAM Stereo	VHF : E2-12, R1-R12, S01-S03, F02-F10, B-Q UHF : E21-69, F21-F69, B21-B69, R21-R69 CABLE TV : S01-S20 HYPER : S21-S41	PAL, SECAM NTSC3.58, NTSC4.43 (VIDEO IN)

Flat Panel	LCD (Liquid Crystal Display) Panel 27 inches (Approx. 68cm measured diagonally).	Sound output	
		Right and Left speaker	2 x 10W (RMS)
Input/Output Terminals [REAR]		General Specifications	
1: 21-pin Euro connector (CENELEC standard)	Inputs for Audio and Video signals. Inputs for RGB. Outputs of TV Video and Audio signals.	Power Requirements	220 - 240V
		Power Consumption/ Standby	110W/0.7W
2: 21-pin Euro connector (CENELEC standard)	Inputs for Audio and Video signals. Inputs for S Video. Outputs of TV Video and Audio signals. (Selectable). Smartlink interface.	Dimensions	Approx. 698 x 574 x 245mm (With stand) Approx. 504 x 526 x 119mm (Without stand)
		Weight	Approx. 14Kg (With stand) Approx. 12Kg (Without stand)
Phono Jacks	Variable Output for audio signals	Supplied Accessories	RM-Y1108 Remote Commander (1) IEC designated R6 battery (2) Mains (Type C-6) Cable (1)
Input/Output Terminals [SIDE]		Other Features	Teletext, Smartlink, Sleep Timer, Picture Freeze, TV system autodetection.
Headphone jack	Stereo mini jack	Remote Control System : Infrared Control	
Audio inputs	Phono jacks	Power requirements	3V dc 2 batteries IEC designation R6 (Size AA)
Video inputs	Phono jacks		
S Video input	4 pin mini DIN		
Design and specifications are subject to change without notice.			

Model Name Item	KLV-27HR3
PAP	OFF
PAT	OFF
RGB Priority	ON
DRC	OFF
Scart 1	ON
Scart 2	ON
Front in (3)	ON
Norm B/G	ON
Norm I	ON
Norm D/K	ON
Norm AUS	OFF
Norm L	ON
Norm SAT	OFF
Norm M	OFF
Teletext	ON
Nicam Stereo	ON

21 pin connector

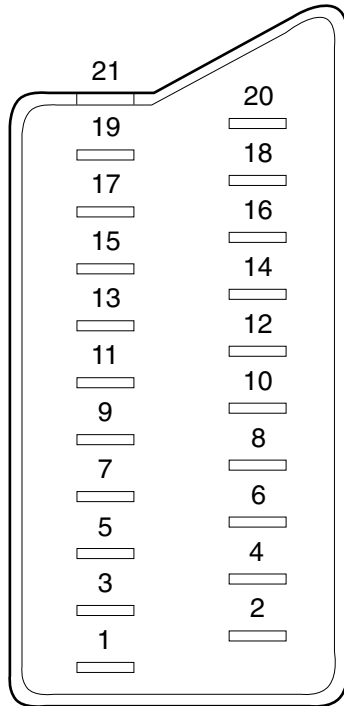

Pin No	1	2	3	Signal	Signal level
1	○	○	○	Audio output B (right)	Standard level : 0.5V rms Output impedance : Less than 1kohm*
2	○	○	○	Audio input B (right)	Standard level : 0.5V rms Output impedance : More than 10kohm*
3	○	○	○	Audio output A (left)	Standard level : 0.5V rms Output impedance : Less than 1kohm*
4	○	○	○	Ground (audio)	
5	○	○	○	Ground (blue)	
6	○	○	○	Audio input A (left)	Standard level : 0.5V rms Output impedance : More than 10kohm*
7	○	●	●	Blue input	0.7 +/- 3dB, 75 ohms positive
8	○	○	○	Function select (AV control)	High state (9.5-12V) : Part mode Low state (0-2V) : TV mode Input impedance : More than 10K ohms Input capacitance : Less than 2nF
9	○	○	○	Ground (green)	
10	○	○	○	Open	
11	○	●	●	Green	Green signal : 0.7 +/- 3dB, 75 ohms, positive
12	○	○	○	Open	
13	○	○	○	Ground (red)	
14	○	○	○	Ground (blanking)	
15	○	-	-	Red input	0.7 +/- 3dB, 75 ohms, positive
	-	○	○	(S signal Chroma input)	0.3 +/- 3dB, 75 ohms, positive
16	○	●	●	Blanking input (Ys signal)	High state (1-3V) Low state (0-0.4V) Input impedance : 75 ohms
17	○	○	○	Ground (video output)	
18	○	○	○	Ground (video input)	
19	○	○	○	Video output	1V +/- 3dB, 75ohms, positive sync 0.3V (-3+10dB)
20	○	-	-	Video input	1V +/- 3dB, 75ohms, positive sync 0.3V (-3+10dB)
	-	○	○	Video input Y (S signal)	1V +/- 3dB, 75ohms, positive sync 0.3V (-3+10dB)
21	○	○	○	Common ground (plug, shield)	

○ Connected ● Not Connected (open) * at 20Hz - 20kHz

Rear Connection Panel

Side Connection Panel

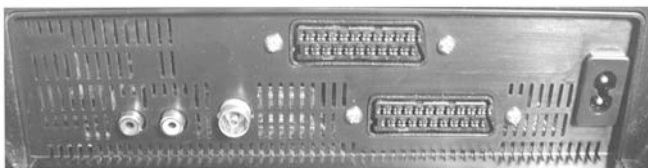

S-Video socket

S Video socket pin configuration		
Pin No	Signal	Signal Level
1	Ground	-
2	Ground	-
3	Y (S signal) input	1V+/- 3dB 75ohm, positive Sync. 0.3V -3 +10dB
4	C (S signal) input	0.3V+/- 3dB 75ohm, positive Sync.

WA1 SELF DIAGNOSTIC SOFTWARE

The identification of errors within the WA1 chassis is triggered in one of two ways :- 1: Busy or 2: Device failure to respond to IIC. In the event of one of these situations arising the software will first try to release the bus if busy (Failure to do so will report with a continuous flashing LED) and then communicate with each device in turn to establish if a device is faulty. If a device is found to be faulty the relevant device number will be displayed through the LED (Series of flashes which must be counted).

Flash Timing Example : e.g. error number 3

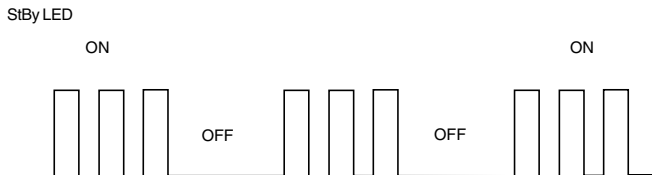

LED Error Code

LED ERROR CODE	ERROR DESCRIPTION
02	A Board Error
03	B Board Error
04	Panel Error
05	EEPROM Error
06	IIC Bus Error
09	Tuner Error
10	Sound Processor Error
11	Panel TV-SVP Error
12	CXA2163 Error
13	Port Expander 1 Error
14	Port Expander 2 Error

SECTION 1 GENERAL

The operating instructions mentioned here are partial abstracts from the Operating Instruction Manual. The page numbers of the Operating Instruction Manual remain as in the manual.

Connecting the Aerial and VCR

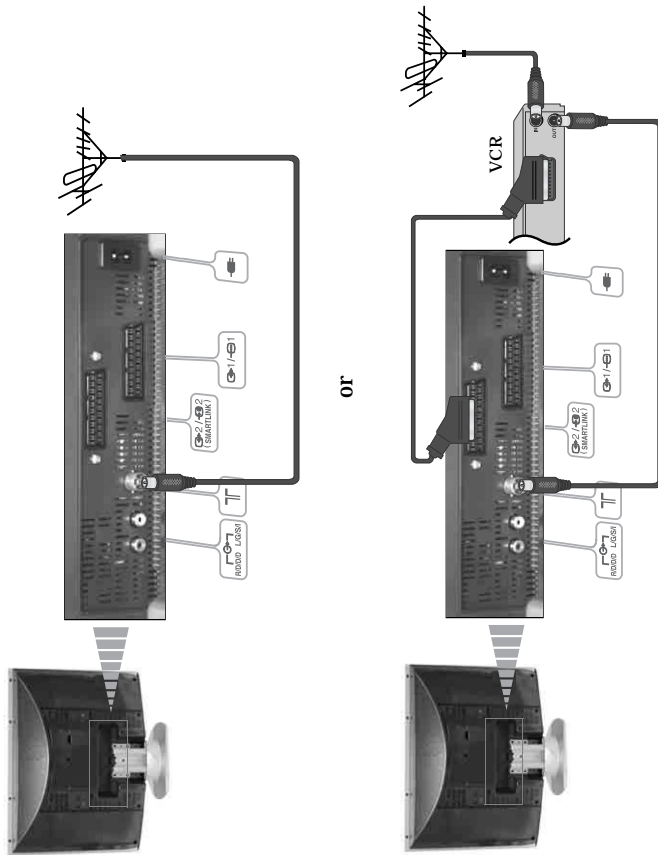

A Make sure to connect the aerial before the Scart.

i For more details regarding VCR connection, refer to "Connecting Equipment to the TV" on page 29.

First Time Operation
Switching On the TV and Automatically Tuning

i The first time you switch on your TV, a sequence of menu screens appear on the TV enabling you to: 1) choose the language of the menu screen 2) choose the country in which you are going to operate the TV, 3) search and store all available channels (TV Broadcast) and 4) change the order in which the channels (TV Broadcast) appear on the screen. However, if you need to change any of these settings at a later date, you can do that by selecting the appropriate option in the (Set Up menu) or by pressing and holding the Auto Start Up button **ASU** on the top of TV set for more than three seconds, see page 11.

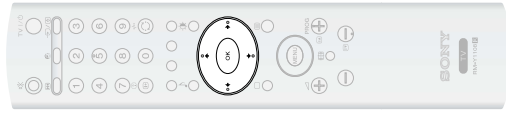

1 Connect the TV plug to the mains socket (220-240V AC, 50Hz).



2 The first time that the TV set is connected, it is usually turned on. If the TV is off, press the **ON/OFF** button to turn on the TV. The first time you switch on the TV, a Language menu appears automatically on the TV screen.

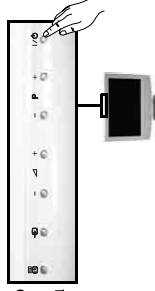

3 Press the **UP**, **DOWN**, **LEFT** or **RIGHT** buttons on the remote control to select your language, then press the **OK** button to confirm your selection. From now on all the menus will appear in your chosen language.

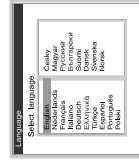

4 The Country menu appears automatically. Press the **UP** or **DOWN** button to select the country in which you are using the TV. Press the **OK** button to confirm your selection.



i If the country in which you want to use the TV set does not appear in the list, select " " instead of a country.

continued...

TV Functions Introducing and Using the Menu System

i Your TV set uses an On-Screen menu system to guide you through the operations. Use the following buttons on the Remote Control to operate the menu system:

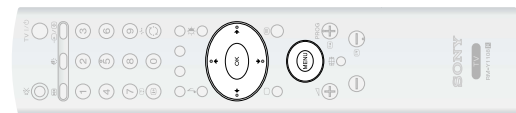

- 1** To switch on the menu screens:
Press the **MENU** button to switch the first level menu on.

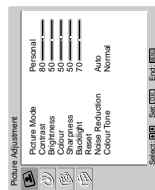

- 2** To navigate through the menus:

- To highlight and select the desired menu or option, press **↓** or **↑**.
- To enter the selected menu or option, press **→**.
- To return to the last menu or option, press **←**.
- To alter the settings of your selected option, press **↔** / **↕** / **↔** or **↕**.
- To confirm and store your selection, press **OK**.

- 3** To switch off the menu screens:
Press the **MENU** button to remove the menu from the screen.

- 5** The Auto Tuning menu appears on the screen. Press the **OK** button to select **Yes**.



- 6** The TV starts to automatically search and store all available broadcast channels for you.

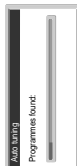

A This procedure could take some minutes. Please be patient and do not press any buttons, otherwise automatic tuning will not be completed.

A If no channels were found during the auto tune process, a message appears automatically on the screen asking you to connect the aerial. Check the aerial connection (refer to page 14). Press the **OK** button to restart the auto tuning process.



- 7** After all available channels are captured and stored, the Programme Sorting menu automatically appears on the screen enabling you to change the order in which the channels are stored.

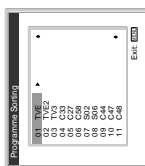

a) If you wish to keep the broadcast channels in the tuned order, go to step 8.

b) If you wish to store the channels in a different order:

- 1 Press the **↓** or **↑** button to select the programme number with the channel (TV Broadcast) you wish to move. Press the **→** button.
- 2 Press the **↓** or **↑** button to select the new programme number position for your selected channel (TV Broadcast). Press the **OK** button to store
- 3 Repeat steps b)1 and b)2 if you wish to change the order of the other channels.

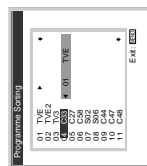

- 8** Press the **MENU** button to remove the menu from the screen

👍 Your TV set is now ready for use

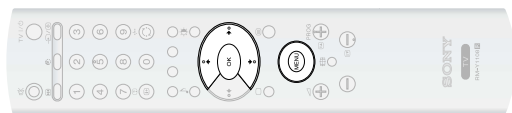

The Picture Adjustment Menu



1 The "Picture Adjustment" menu allows you to alter the picture settings.

To do this:

Press the **MENU** button and then press **OK** to enter this menu. Next, press **▼** or **▲** to select the desired option and press **OK**. Finally, read below how to operate into each option.

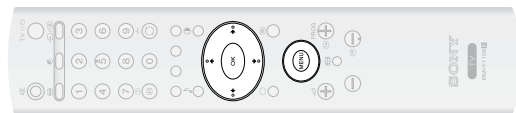
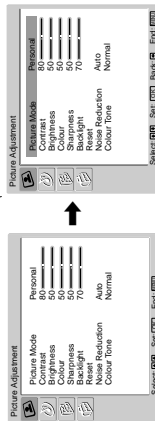

Picture Mode This option allows you to customise the picture mode based on the programme you are watching. After selecting this option press **OK**. Next, press repeatedly **▼** or **▲** to select:

- Live** (for live broadcast programmes, DVD and Digital Set Top Box receivers).
- Personal** (for individual settings).
- Movie** (for films).

Once you have selected your desired option, press **OK** to store.

1 "Brightness", "Colour", "Sharpness" and "Backlight" level of "Live" and "Movie" mode are fixed on the factory to get the best picture quality.

Contrast Press **◀** or **▶** to reduce or enhance picture contrast. Next, press **OK** to store.

Brightness Press **◀** or **▶** to darken or brighten the picture. Next, press **OK** to store.

▲ This option only appears and can only be adjusted if "Picture Mode" is set to "Personal".

Colour Press **◀** or **▶** to decrease or to increase color intensity. Next press **OK** to store.

▲ This option only appears and can only be adjusted if "Picture Mode" is set to "Personal".

Hue Press **◀** or **▶** to decrease or to increase the green tones. Next press **OK** to store.

▲ This option only appears for NTSC signal (e.g. USA video tapes).

Sharpness Press **◀** or **▶** to soften or to sharpen the picture. Next press **OK** to store.

▲ This option only appears and can only be adjusted if "Picture Mode" is set to "Personal".

Backlight Press **◀** or **▶** to darken or brighten the backlight.

▲ This option only appears and can only be adjusted if "Picture Mode" is set to "Personal".

Reset

Press **OK** to reset the picture to the factory preset levels.

Noise Reduction

This option is set to **Auto** to automatically reduce the snowy picture visible in the weak broadcast signal. However, it can be modified. After selecting this option press **▶**. Next, press **▼** or **▲** to select **Off**. Finally, press **OK** to store.

Colour Tone

This option allows you to alter the tint of the picture. After selecting this option press **▶**. Next, press repeatedly **▼** or **▲** to select: **Warm** (gives the white colours a red tint). **Normal** (gives the white colours a neutral tint). **Cool** (gives the white colours a blue tint). Finally press **OK** to store.

The Sound Adjustment Menu

i The "Sound Adjustment" menu allows you to alter the sound settings.

To do this:
Press the **MENU** button and press **↓** to select **②**, then press **OK** to enter this menu. Next, press **↓** or **↑** to select the desired option and press **OK**. Finally, read below how to operate into each option.

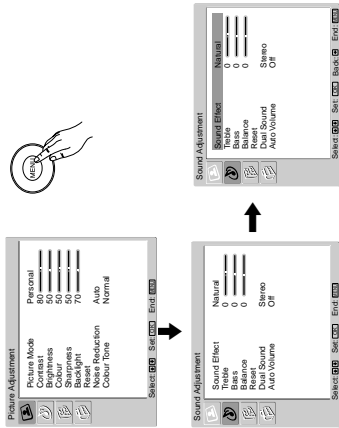

Sound Effect

This option allows you to customise the sound effect. After selecting this option press **OK**. Next, press repeatedly **↓** or **↑** to select:

- Natural** Enhances clarity, detail and presence of sound by using "BBE High Definition Sound system"*.
Dynamic "BBE High Definition Sound system"*. Intensifies clarity and presence of sound for better intelligibility and musical realism.
- Off** Flat response.



Once you have selected your desired option, press **OK** to store. This function has no effect on headphones sound.

Treble

Press **←** or **→** to decrease or to increase higher-frequency sounds. Next, press **OK** to store.

Bass

Press **←** or **→** to decrease or to increase the lower-frequency sounds. Next, press **OK** to store.

Balance

Press **←** or **→** to emphasise the left or the right speaker. Next, press **OK** to store.

Reset

Press **OK** to reset the sound to the factory preset levels.

Dual Sound

Press **→**. Next:
For a Stereo broadcast:
Press **↓** or **↑** to select Stereo or Mono. Next press **OK** to store.
For a bilingual broadcast:
Press **↓** or **↑** to select Mono (for mono channel if available), A (for channel 1) or B (for channel 2). Next press **OK** to store.

Auto Volume

Press **→**. Next press **↓** or **↑** to select On (the volume level of the channels will stay the same, independent of the broadcast signal, e.g. in the case of advertisements) or Off (the volume level changes according to the broadcast signal). Next press **OK** to store.



This function has no effect on headphones sound.



* The "BBE High Definition Sound system" is manufactured by Sony Corporation under license from BBE Sound, Inc. It is covered by U.S. Patent No. 4,638,258 and No. 4,482,866. The word "BBE" and BBE Symbol are trademarks of BBE Sound, Inc.

The Features Menu

i The "Features" menu allows you to alter various settings of the TV.

To do this:
Press the **MENU** button and press **↓** twice to select **③**, then press **OK** to enter this menu. Next, press **↓** or **↑** to select the desired option and press **OK**. Finally, read below how to operate into each option.

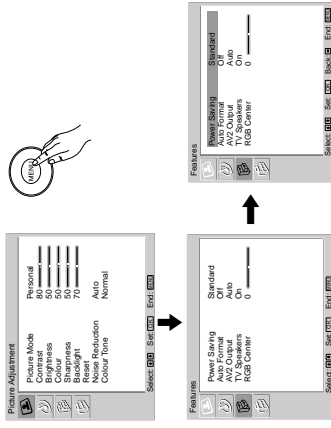

POWER SAVING

This option allows you to reduce the power consumption of this TV.

To do this:

After selecting the option, press **OK**. Then, press **↓** or **↑** to select **Reduce**. Next, press **OK** to store.

AUTO FORMAT

This option allows you to automatically change the aspect ratio of the screen.

To do this:

After selecting the option, press **OK**. Then, press **↓** or **↑** to select **On** (if you wish the TV set to automatically switch the screen format according to the broadcast signal) or **Off** (if you wish to keep your preference). Finally, press **OK** to store.

i Even if you have selected "On" or "Off", you can always modify the format of the screen by pressing **⏏** repeatedly on the remote control to select one of the following formats:

- SMART**: Imitation of wide screen effect for 4:3 broadcast.
- 4/3**: Conventional 4:3 picture size, full picture information.
- 14/9**: Compromise between 4:3 and 16:9 picture size.
- ZOOM**: Widescreen format for letterbox movies.
- WIDE**: For 16:9 broadcast. Full picture information.



In "SMART", "ZOOM" and "14/9" modes, parts of the top and bottom of the screen are cut off. Press **↓** or **↑** to adjust the position of the image on the screen (e.g. to read subtitles).

According to the format of diffusion, black bands can always appear whatever the selected mode.

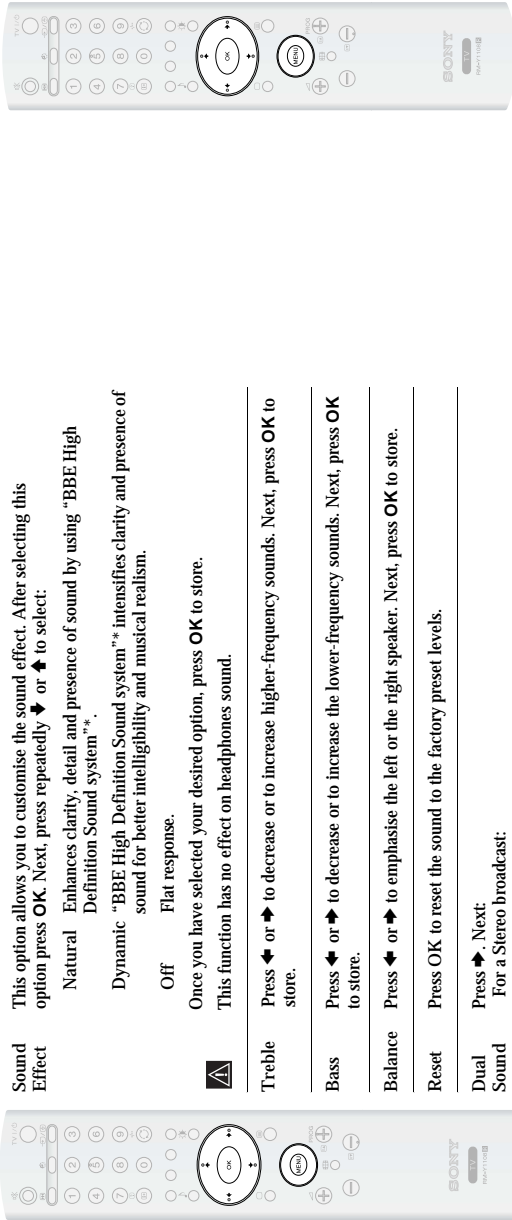

continued...

The Set Up Menu

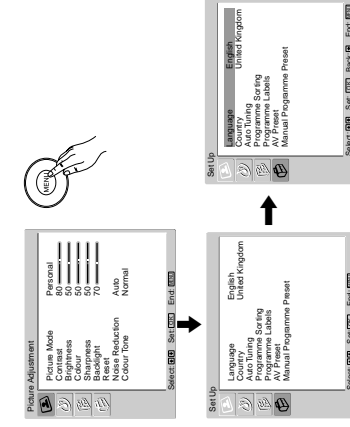

i The "Set Up" menu allows you to alter various options on this TV.

To do this:
Press the **MENU** button and press **↵** three times to select **Ⓜ** then press **OK** to enter this menu. Next, press **↵** or **⬅** to select the desired option and press **OK**. Finally, read below how to operate into each option.

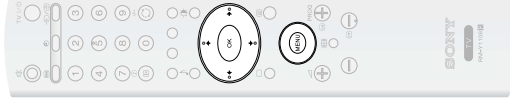

LANGUAGE

This option allows you to select the language that menus are displayed in.

To do this:
After selecting the option, press **OK** and then proceed in the same way as in step 3 of the section "Switching On the TV and Automatically Tuning" on page 15.

COUNTRY

This option allows you to select the country in which you wish to operate the TV set.

To do this:
After selecting the option, press **OK** and then proceed in the same way as in step 4 of the section "Switching On the TV and Automatically Tuning" on page 15.

AUTO TUNING

This option allows you to automatically search for and store all available TV channels.

To do this:
After selecting the option, press **OK** and then proceed in the same way as in the steps 5 and 6 of the section "Switching On the TV and Automatically Tuning" on page 16.

PROGRAMME SORTING

This option allows you to change the order in which the channels (TV Broadcast) appear on the screen.

To do this:
After selecting the option, press **OK** and then proceed in the same way as in the step 7 of the section "Switching On the TV and Automatically Tuning" on page 16.

AV2 OUTPUT

The "AV2 Output" option allows you to select the source to be output from the Scart connector **Ⓢ/2** so that you can record from this Scart the signal coming from the TV or the signal that is being viewed on the TV.

i If your VCR or DVD recorder supports SmartLink, this procedure is not necessary.

To do this:
Once you have entered into the "Features" menu as it is explained in the previous page and after selecting the option, press **OK**. Then press **↵** or **⬅** to select the desired output signal:

TV to output the aerial source.
AUTO to output the signal that is being viewed on the TV.

A If you select "AUTO", the output signal will always be the same one that is displayed on the screen. If you have connected a decoder to the Scart **Ⓢ/2** or to a VCR connected to this Scart, please remember to change back the "AV2 Output" to "TV" for correct unscrambling. Alternatively, set the "Decoder" option in the "Manual Programme Preset" menu to "On" for the scrambled programme. For more details refer to page 26.

TV SPEAKERS

This option allows you to turn off the TV speakers e.g. to listen to the sound through external audio equipment connected to the TV.

To do this:
Press the **↵** or **⬅** buttons to select one of the following options, then press the **OK** button.

On The sound is output from the TV speakers.

One Time Off The TV speakers are temporarily turned off allowing you to listen to the sound from external audio equipment.

i The "TV Speakers" option automatically returns to "On" when the TV set is switched off.

Permanent Off The TV speakers are permanently turned off allowing you to listen to the sound from external audio equipment.

A To turn on the TV speakers again, change the "TV Speakers" option to "On".

RGB CENTER

A This option is only available if an RGB source has been connected to the Scart connector **Ⓢ/1** on the rear of TV. When viewing an RGB signal, the picture may need some adjusting. This option allows you to adjust the horizontal picture position so that the picture is in the middle of the screen.

To do this:
Once you have entered the "Features" menu as it is explained in on page 21 and while watching an RGB source select the "RGB Center" option and press **OK**. Then press **⬅** or **➡** to adjust the centre of the picture between -5 and +5. Finally press **OK** to confirm and store.

The Manual Programme Preset Menu

The "Manual Programme Preset" option in the "Set Up" menu allows you to manually tune individual channels.

To do this:
Press the **MENU** button and press **↕** three times to select **☰**, then press **OK** to enter the "Set Up" menu. Next, press **↕** or **↗** to select "Manual Programme Preset" and press **OK**. Finally, read below how to operate into each option.

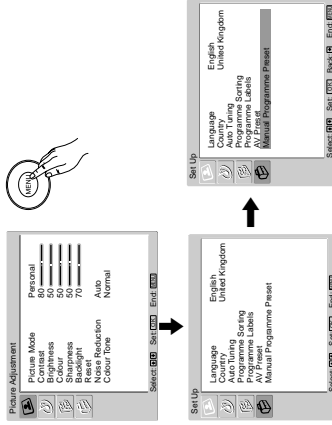

The Manual Programme Preset option allows you to:

- a) Preset channels or the VCR channel one by one to the programme order of your choice.

To do this:

- 1 Once you have entered the "Set Up" menu as it is explained on page 23 and after selecting the "Manual Programme Preset" option, press **OK**. Next with Programme option highlighted press **OK**. Press **↕** or **↗** to select which programme number you want to preset the channel on (for VCR, select programme number "0"). Then press **↔**.
- 2 **☰** The following option is only available depending on the country you have selected in the "Country" menu.
After selecting the System option, press **OK**. Then press **↕** or **↗** to select the TV Broadcast system (B/G for western European countries, D/K for eastern European countries, L for France or I for United Kingdom). Then press **↔**.
- 3 After selecting the Channel option, press **OK**. Next press **↕** or **↗** to select the channel tuning ("C" for terrestrial channels or "S" for cable channels). Then press the number buttons to enter directly the channel number of the TV Broadcast or the channel of the VCR signal. If you do not know the channel number, press **↕** and **↗** or **↔** to search for it. When you have tuned the desired channel, press **OK** twice to store.

Repeat all the above steps to tune and store more channels.

- b) Label a channel using up to five characters.

To do this:

Once you have entered the "Set Up" menu as it is explained on page 23 and after selecting the "Manual Programme Preset" option, press **OK**. Next with the Programme option, highlighted press the **PROG +/-** button to select the programme number with the channel you wish to name. When the programme you want to name appears on the screen, press **↕** or **↗** to select the Label option and press **OK**. Then, with the first element highlighted, press **↕**, **↗**, **↔** or **↖** to select the letter; next press **OK**. When you have finished, press **↕**, **↗**, **↔** or **↖** to select the word "End" on the screen and finally press **OK** to turn off the menu from the screen. Finally press **OK** to store.

- ☰** To correct a letter, select "**☰**" on the screen to go back and press **OK**.
For a blank, select "**☐**" on the screen and press **OK**.

PROGRAMME LABELS

This option allows you to name a channel using up to five characters (letters or numbers).

To do this:

- 1 Once you have entered the "Set Up" menu as it is explained in the previous page and after selecting this option, press **OK**, then press **↕** or **↗** to select the programme number with the channel you wish to name. Next press **OK**.
 - 2 With the first element of the Label column highlighted, press **OK** and **↕**, **↗**, **↔** or **↖** to select the letter, next press **OK**.
When you have finished, press **↕**, **↗**, **↔** or **↖** to select the word "End" on the screen and finally press **OK** to turn off the menu from the screen.
- ☰** To correct a letter, select "**☰**" on the screen to go back and press **OK**.
For a blank, select "**☐**" on the screen and press **OK**.

AV PRESET

This option allows you to:

- a) Designate a name to the external equipment you have connected to the input sockets of the TV set.

To do this:

- 1 Once you have entered the "Set Up" menu as it is explained in the previous page and after selecting this option, press **OK**, then press **↕** or **↗** to select the input source you wish to name: AV1 and AV2 for the rear Scarts and AV3 for side connectors. Next press **OK** twice.
 - 2 A label automatically appears in the label column:
a) If you want to use one of the predefined labels, press **↕** or **↗** to select the desired label and finally press **OK**.
The total predefined labels are: VIDEO, DVD, CABLE, GAME, CAM (camcorder) or SAT (satellite).
 - b) If you want to set a different label, select Edit and press **OK**. Then, with the first element highlighted, press **↕**, **↗**, **↔** or **↖** to select the letter, next press **OK**. When you have finished, press **↕**, **↗**, **↔** or **↖** to select the word "End" on the screen and finally press **OK** to turn off the menu from the screen.
- ☰** To correct the letter, select "**☰**" on the screen to go back and press **OK**.
For a blank, select "**☐**" on the screen and press **OK**.

- b) Change the input sound level of the optional equipment connected.

To do this:

Once you have entered the "Set Up" menu as it is explained in the previous page and after selecting this option press **OK**, then press **↕** or **↗** to select the input source you want to alter the input sound level: AV1 and AV2 for the rear Scarts and AV3 for side connectors. Next press twice **↔** to highlight the Sound Offset column. Finally press **OK** and **↕** or **↗** to alter the input sound level between -9 and +9.

Other Functions



c) Fine tune the broadcast reception. Normally the automatic fine tuning (AFT) will give the best possible picture, however you can manually fine tune the TV to obtain a better picture reception in case the picture is distorted.

To do this:
While watching the channel (TV Broadcast) you wish to fine tune, and once you have entered the "Set Up" menu as it is explained on page 23 and after selecting the "Manual Programme" option, press **OK**. Then press **↔** or **↕** to select the AFT option and press **↔**. Next press **↔** or **↕** to adjust the fine tuning between -15 and +15. Finally press **OK** twice to store.

d) Improve the sound for individual channels in the case of distortion in mono broadcasts. (Not available when "System" is set to "L.")
Sometimes a non standard broadcast signal can cause sound distortion or intermittent sound muting when watching mono programmes. The Audio Filter option allows you to reduce this effect.

❶ If you do not experience any sound distortion, we recommend that you leave the Audio Filter option set to the default setting of "Off".

To do this:
Once you have entered the "Set Up" menu as it is explained on page 23 and after selecting the "Manual Programme Preset" option, press **OK**. Next, press **↔** or **↕** to select the Audio Filter option and press **↔**. Next press **↔** or **↕** to select Off, Low or High.

❷ You can not receive stereo or dual sound when "Low" or "High" is selected.

e) Skip any unwanted programme numbers when they are selected with the **PROG +/-** buttons.

To do this:
Once you have entered the "Set Up" menu as it is explained on page 23 and after selecting the "Manual Programme Preset" option, press **OK**. Next with the Programme option highlighted, press the **PROG +/-** button to select the programme number you want to skip. When the programme you want to skip appears on the screen, press **↔** or **↕** to select the Skip option and press **↔**. Next press **↔** or **↕** to select On. Finally press **OK** twice to confirm and store.

To cancel this function afterwards, select "Off" instead of "On" in the step above.

f) View and record scrambled channels (e.g. from a pay TV decoder) when using a decoder connected to Scart **⏪-2/-⏩** directly or through a VCR.

❸ This option is only available depending on the country you have selected in the "Country" menu.

To do this:
Once you have entered the "Set Up" menu as it is explained on page 23 and after selecting the "Manual Programme Preset" option, press **OK**. Next press **↔** or **↕** to select the Decoder option and press **↔**. Next press **↔** or **↕** to select On. Finally press **OK** twice to confirm and store.

To cancel this function afterwards, select "Off" instead of "On" in the step above.

Sleep Timer
This function allows you to set the TV to switch itself automatically to standby mode after a specified time period. The following time periods can be selected: 30, 60, 90 and 120 minutes.

To do this:

Press the **⏻** button on the remote control repeatedly until the desired time period appears on the screen.

When the Sleep Timer feature is on, the **⏻** (Standby/Sleep) indicator on the TV lights up in red.

To cancel the Sleep Timer feature:

Press the **⏻** button on the remote control repeatedly until "Off" appears on the screen.

If you switch off the TV and switch it on again, the Sleep Timer feature is reset to "Off".
Press the **⏻** button on the remote control to display the time remaining before the TV switches to standby mode.

The message "Sleep Timer will end soon. Power will be turned off." Appears on the screen 1 minute before the TV switches to the standby mode.

Picture Freeze

This function allows you to freeze the TV picture (e.g. to make a note of a telephone number or recipe).

To do this:

Press the **⏻** button on the remote control to freeze the picture. A window is displayed in the bottom left of the screen showing the currently selected channel. Press the **⏻** button again to remove the window. Press the **⏻** button again to cancel the Picture Freeze and return to normal TV mode.

Adjusting the position of the Picture Freeze window

The position of the window displaying the currently selected channel can be adjusted.

To do this

With the TV in Picture Freeze mode, press the **⏻**, **↔**, **↕** or **↔** buttons to adjust the position of the window on the TV screen.

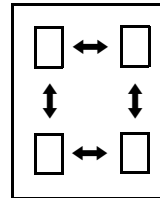

Teletext



Teletext is an information service transmitted by most TV stations. The index page of the Teletext service (usually page 100) gives you information on how to use the service. To operate Teletext, use the remote control buttons as indicated below.

Make sure you use a channel (TV Broadcast) with a strong signal, otherwise Teletext errors may occur.

To switch on Teletext

After selecting the TV channel which carries the Teletext service you want to view, press **⏏**.

Each time you press **⏏**, the screen changes cyclically as follows:

Teletext mode **⏏** Teletext Superimpose mode **→** TV mode **→** Teletext mode **→** (repeat).

To select a Teletext page

Input three digits for the page number, using the number buttons.

If you make a mistake, retype the correct page number.

If the counter on the screen continues searching, it is because this page is not available. In this case, input another page number.

To access the next or preceding page

Press **PROG + (⏏)** or **PROG - (⏏)**.

To freeze a Teletext page

Some Teletext pages have sub-pages which follow on automatically. To stop them, press

⏏/⏏. Press it again to cancel the freeze.

To reveal concealed information (e.g. answers to a quiz)

Press **⏏/⏏**. Press it again to conceal the information.

To change brightness of Teletext:

Whilst you are viewing Teletext, press **⏏** repeatedly to choose between four different options of brightness.

To switch off Teletext

Press **⏏**.



If wrong Teletext characters appear for Cyrillic languages, we recommend you set the "Language" option in the "Set Up" menu to "Russia" if your country does not appear in the list. For details, refer to page 23.

Fastext

The Fastext service lets you access pages with one push of a button.

Whilst you are in the Teletext mode and Fastext is broadcast, a colour coded menu appears at the bottom of the Teletext page. Press the colour button (red, green, yellow or blue) to access the corresponding page.

Additional Information

Connecting Equipment to the TV

Using the following instructions you can connect a wide range of optional equipment to your TV set. Connecting cables are not supplied.

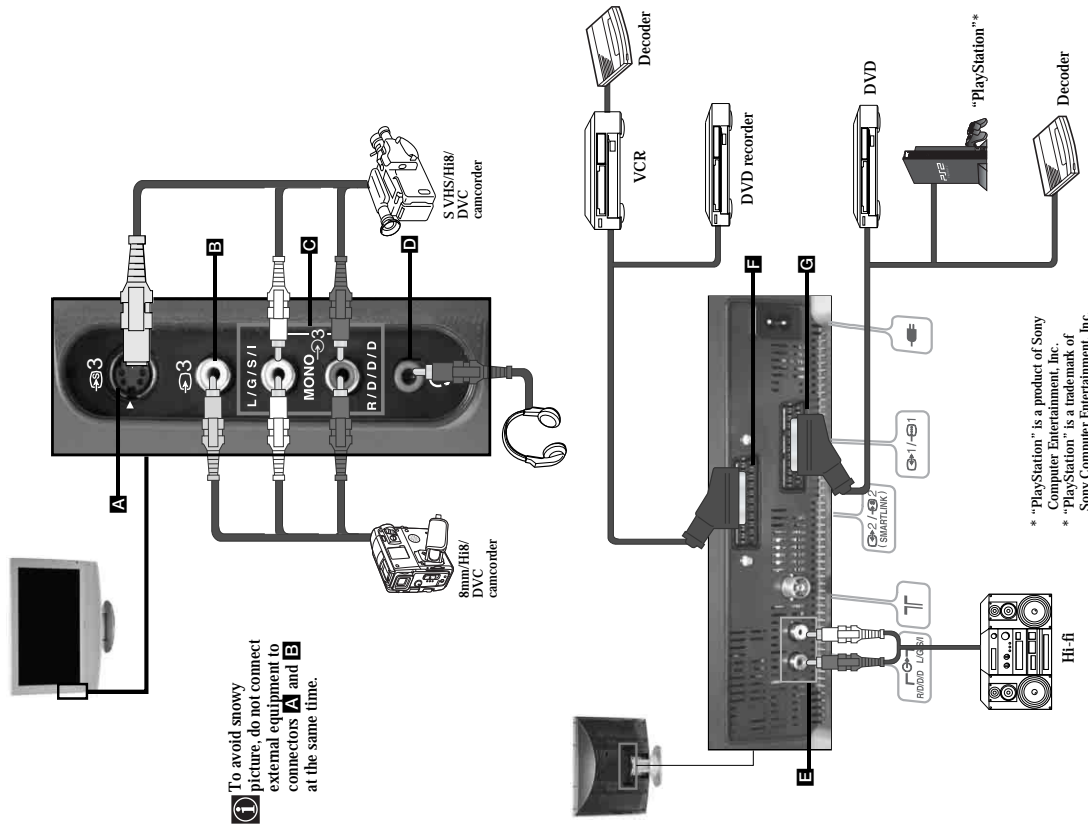









To avoid snowy picture, do not connect external equipment to connectors **A** and **B** at the same time.

* "PlayStation" is a product of Sony Computer Entertainment, Inc.
* "PlayStation" is a trademark of Sony Computer Entertainment, Inc.



continued...

Viewing pictures from equipment connected to the TV

- 1 Connect your equipment to the designated TV socket, as indicated on page 29.
 - 2 Switch on the connected equipment.
 - 3 To watch the picture from the connected equipment, press the  /  button repeatedly until the correct input symbol appears on the screen.
- | Symbol | Input Signals |
|---|---|
|  1 | Audio / video input through the Scart connector G |
|  1 | RGB input signal through the Scart connector G . This symbol appears only if an RGB source has been connected. |
|  2 | Audio/video input signal through the Scart connector F . |
|  2 | S Video Input signal through the Scart connector F . This symbol appears only if an S Video source has been connected. |
|  3 | Video input signal through the phono socket E and Audio input signal through G . |
|  3 | S Video Input signal through the side S Video input jack A and Audio signal through G . This symbol appears only if an S Video source has been connected. |
- 4 Press the  button on the remote control to return to the normal TV picture.



For Mono Equipment

Connect the phono plug to the L/G/S/I socket on the side of the TV and select  3 or  3 input signal using the instructions above. Next, refer to the "Sound Adjustment" section of this manual and set "Dual Sound" option to "A" on the sound menu screen (see page 20).

Connecting a VCR

To connect a VCR, please refer to the section "Connecting the aerial and VCR" of this instruction manual on page 14.

Connecting a VCR or a DVD recorder that supports SmartLink

 SmartLink is a direct link between the TV set and a SmartLink compatible VCR/DVD recorder. For more information on SmartLink, please refer to the instruction manual of your SmartLink VCR/DVD recorder.

If you use a VCR or a DVD recorder that supports SmartLink, please connect the VCR or the DVD recorder to the TV using a Scart lead to the Scart  **F**.

If you have connected a decoder or a Set Top Box to the Scart **F** or through a VCR connected to this Scart

Select the "Manual Programme Preset" option in the "Set Up" menu and after entering in the "Decoder**" option, select "On" (refer to page 26). Repeat this option for each scrambled signal.

**This option is only available depending on the country you have selected in the "Country" menu.

Connecting Audio Equipment to the TV

To listen to the sound from TV on Hi-fi equipment.

Connect your audio equipment to the audio output sockets  if you wish to amplify the audio output from the TV. Next, using the menu system, select the "Features" menu and set the "TV Speakers" to "Permanent Off" (see page 22).

The volume of the external speakers can be altered by pressing the volume buttons on the TV remote control.

The treble and bass setting can also be altered through the "Sound Adjustment" menu (see page 20).

Technical Specifications

Panel System: LCD (Liquid Crystal Display) Panel	Rear Terminals: AV1: 1 21-pin Scart connector (CENELEC standard) including audio/video input, RGB input, TV audio/video output.
TV System: (Depending on the Country/region selection) B/G/H, D/K, L, I	AV2: 2 (SMARTLINK) 21-pin Scart connector (CENELEC standard) including audio/video input, S video input, selectable audio/video output and Smartlink interface.
Colour System: PAL, SECAM NTSC 3.58, 4.43 (Only Video In)	Audio Outputs (left/right) – phono jacks.
Aerial: 75 ohm external terminal for VHF/UHF	Aerial connector (RF In)
Channel Coverage: (Depending on the Country/region selection) VHF: E2-E12 UHF: E21-E69 CATV: S1-S20 HYPER: S21-S41 R1-R12, R21-R69 D/K: F2-F10, B-Q, F21-F69 L: I: UHF B21-B69	Side Terminals: AV3: 3 S video input (4-pin mini DIN) 3 Video input (phono jack) 3 Audio input (phono jacks) headphones jack
Screen Size: 27 Inches (approx. 68 cm, measured diagonally)	Accessories supplied: One Remote Control (RM-Y1108), Two Size AA batteries (R6 type), One Mains lead (Type C-6)
Display Resolution: 1280 dots (horizontal) x 720 lines (vertical)	Optional Accessory: Wall-Mount Bracket SU-LW1, TV Stand SU-PG100.
Power Requirement: 220-240V AC; 50/60 Hz	Other Features: Teletext, Fasttext, TOPtext (depending on availability) Sleep Timer Picture Freeze
Power Consumption: 110 W	Smartlink (Direct link between your TV and a compatible VCR or DVD recorder. For more information on Smartlink, please refer to the instruction manual of your VCR or DVD recorder.) TV system autodetection
Standby Power Consumption: 0.7 W	This TV is compatible with the VESA universal wall stand system.
Sound Output: 10 W + 10 W	
Dimensions (w x h x d): With stand, approx. 698 x 574 x 245 mm. Without stand, approx. 504 x 526 x 119 mm.	
Weight: With stand, approx. 14 Kg. Without stand, approx. 12 Kg.	

Design and specifications are subject to change without notice.

This instruction manual has been printed on:
Ecological Paper - Totally Chlorine Free

Troubleshooting

Here are some simple solutions to problems which may affect the picture and sound.

Problem	Possible solution
No picture	
No picture (screen is dark and no sound).	Check the aerial connection. Connect the TV to the mains, and press the power switch on the top side of the TV set. If the (standby) indicator is on, press TV on the remote control.
The TV turns off automatically. (The TV enters the standby mode.)	Check if the Sleep Timer is activated (page 27).
No picture or no menu information from equipment connected to the Scart connector.	Check that the optional equipment is on and press the button repeatedly on the remote control until the correct input symbol is displayed on the screen (page 31). Check the connection between the optional equipment and the TV.
Poor picture/Unstable picture	
Double images or ghosting.	Check aerial/cable connections. Check the aerial location and direction.
Only snow and noise appears on the screen.	Check if the aerial is broken or bent. Check if the aerial has reached the end of its serviceable life (3-5 years in normal use, 1-2 years at the seaside)
Dotted lines or stripes.	Keep the TV away from electrical noise sources such as cars, motorcycles, or hair-dryers.
No colour on colour programmes.	Using the menu system, select the "Picture Adjustment" menu and select "Reset" to return to the factory settings (page 19). If you set the "Power Saving" function to "Reduce," picture colours may become dimmer (page 21).
Some tiny black points and/or bright points on the screen.	The picture of the display is composed of pixels. Tiny black points and/or bright points (pixels) on the screen, do not indicate a malfunction.
The picture is too bright.	Using the menu system, select the "Picture Adjustment" menu and select "Picture Mode." Then select the desired picture mode (page 18).
Picture (stripe) noise.	Make sure that the aerial is connected. Keep the aerial cable away from other connecting cords. Do not use 300-ohm twin lead cables as interference may occur.

continued...

Problem	Possible solution
Stripe noise during playback/recording of a VCR.	Video head interference. Keep your VCR away from the TV. Leave a space of 30 cm between your VCR and the TV set to avoid noise. Avoid installing your VCR in front or at the side of the TV set.
Poor or no picture (screen is dark), but good sound.	Using the menu system, select the "Picture Adjustment" menu and select "Reset" to return to the factory settings (page 19).
Noisy picture when viewing a TV channel.	Using the menu system, select the "Manual Programme Preset" option in the "Set Up" menu and adjust Fine Tuning (AFT) to obtain better picture reception (page 26). Using the menu system, set the "Noise Reduction" option in the "Picture Adjustment" menu to reduce the noise in the picture (page 19).
Distorted picture when changing programmes or selecting teletext.	Turn off any equipment connected to the Scart connector on the rear of the TV set.
Cannot operate the menu	If the item you want to select appears in a pale colour is because you cannot select it.
Wrong characters appear when viewing teletext	Using the menu system, enter the "Country" option in the "Set Up" menu and select the country in which you operate the TV set (page 23).
No sound/Noisy sound	Press the \triangleleft +/- or \triangleright (mute) on the remote control. Check that "TV Speakers" option is set to "On" in the "Features" menu (page 22).
Good picture, no sound.	Make sure that the aerial is connected. Keep the aerial cable away from other connecting cables. Do not use 300-ohm twin lead cables as interference may occur. Communication problems may occur if the infrared communication equipment (e.g. infrared cordless headphones) is used near the TV. Please use headphones other than infrared cordless headphones, move the infrared transceiver away from the TV until the noise is eliminated, or move the transmitter and receiver of the infrared communication equipment closer together. Using the menu system, select "Audio Filter" from the "Manual Programme Preset" menu. Next select "Low" or "High" (see page 26).
Audio noise.	
Unable to receive a stereo or dual sound broadcast	Check that the "Audio Filter" option in the "Manual Programme Preset" menu is set to "Off". (see page 26).
Strange sound	Changes in room temperature sometimes causes the TV cabinet to expand or contract, which can make slight noises. This does not indicate a malfunction.
The TV cabinet creaks.	
The TV buzzes.	There might be a surge sound when turning on the TV. This does not indicate a malfunction.
Remote Control	Replace the batteries.
Remote control does not function.	
The \odot (standby) or TV \blacksquare (power on) indicators on the TV flashes	Contact your nearest Sony service centre.
 If you continue to experience problems, have your TV serviced by qualified personnel. Never open the casing yourself.	

SECTION 2 DISASSEMBLY

2-1. REAR CABINET ASSEMBLY REMOVAL

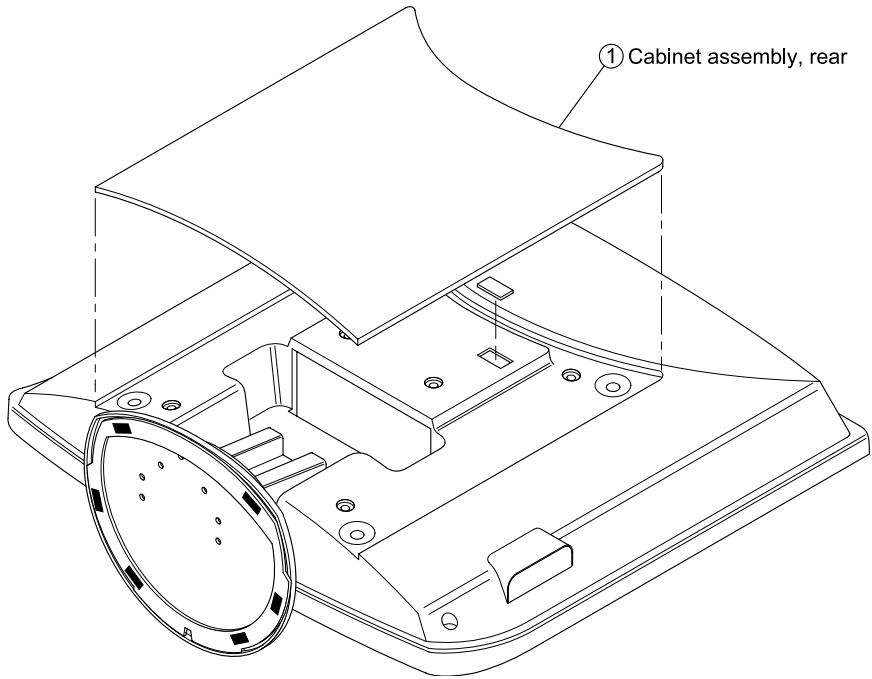

2-2. REAR COVER REMOVAL

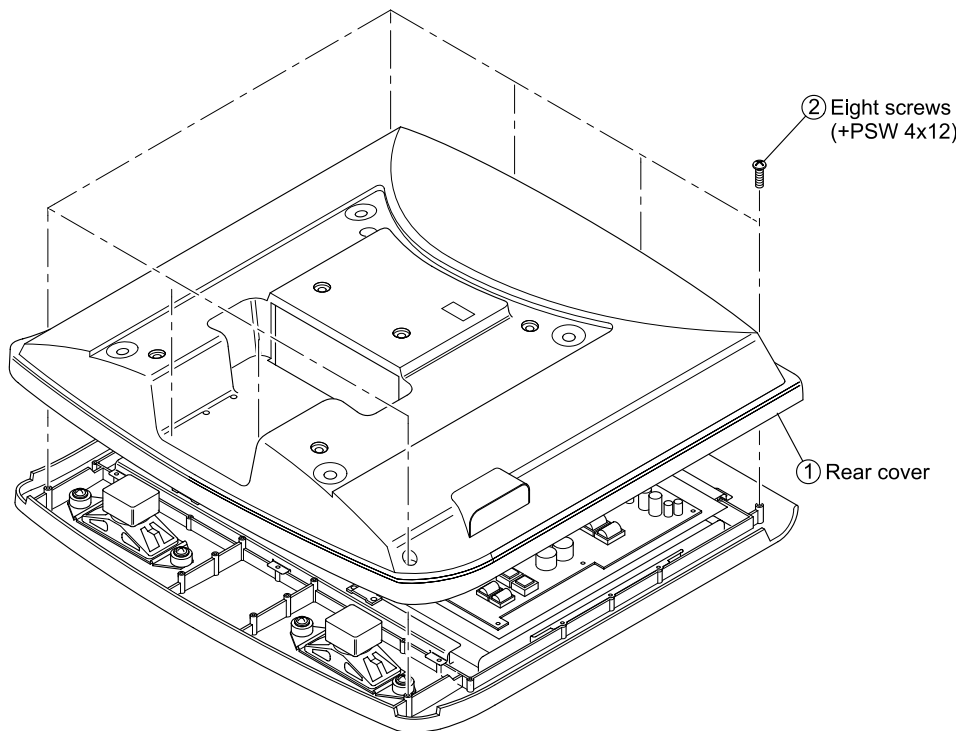

2-3. A BOARD REMOVAL

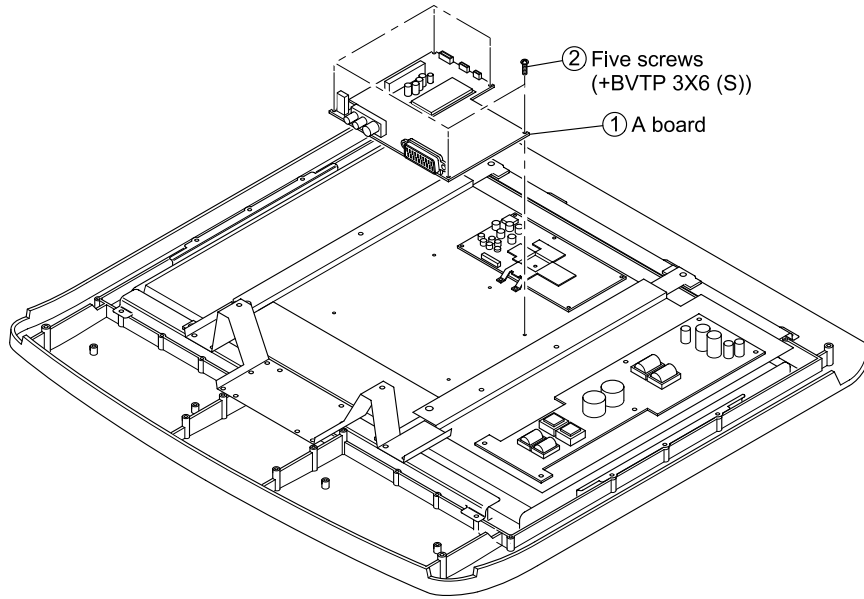

2-4. G2 BOARD REMOVAL

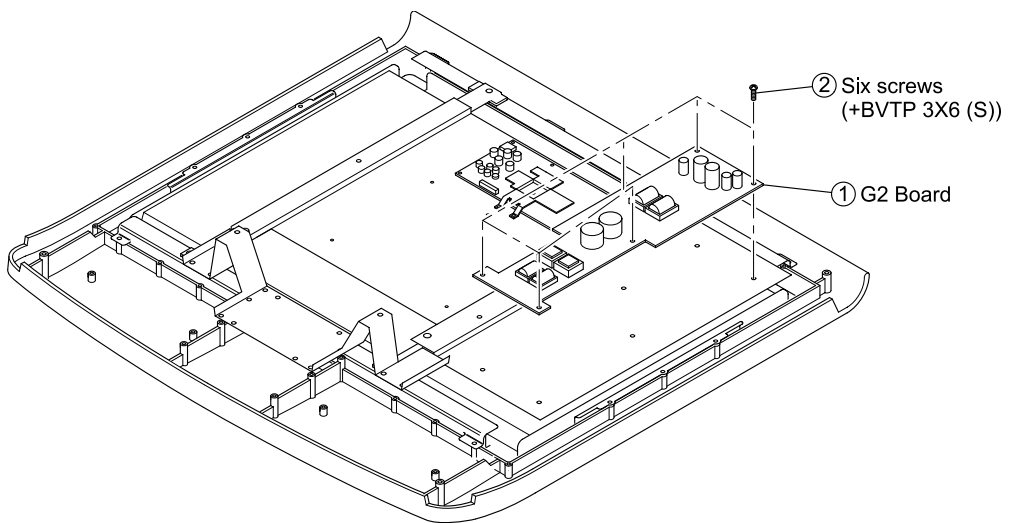

2-5. H1 BOARD REMOVAL

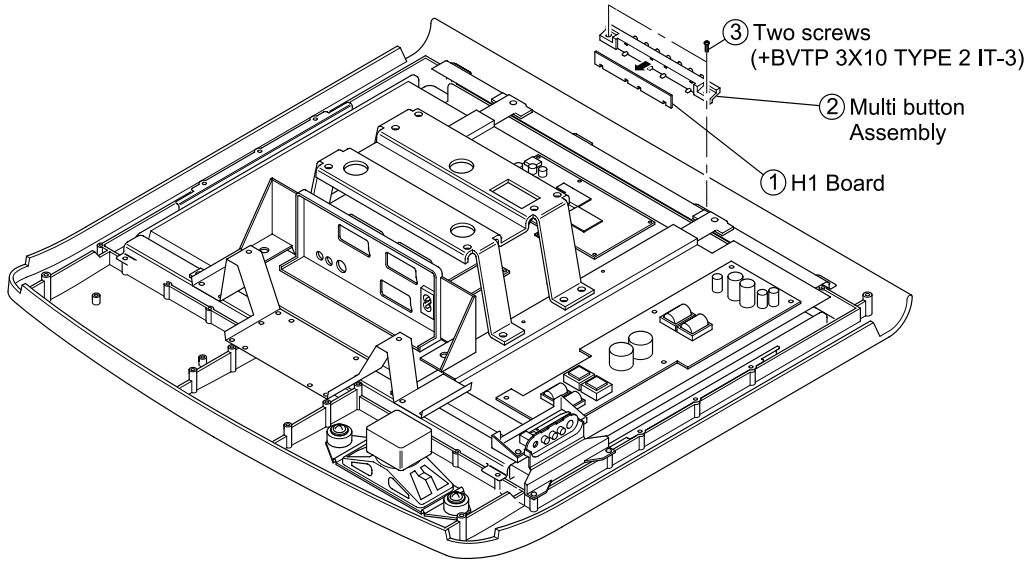

2-6. H2 BOARD REMOVAL

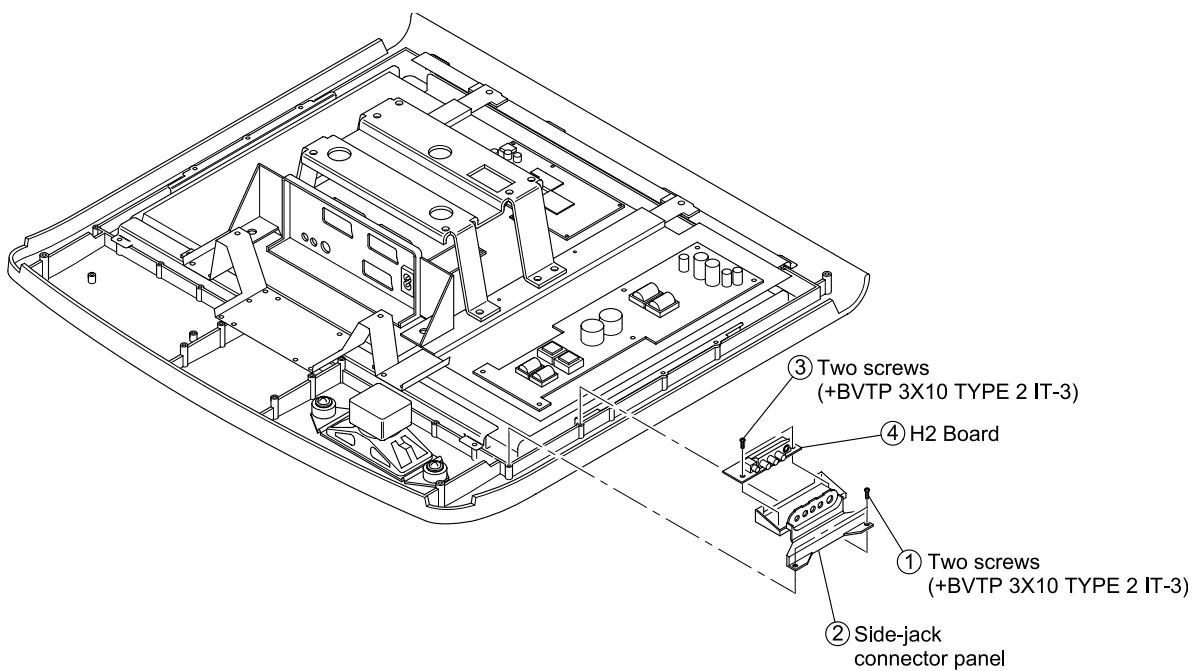

2-7. H3 BOARD REMOVAL

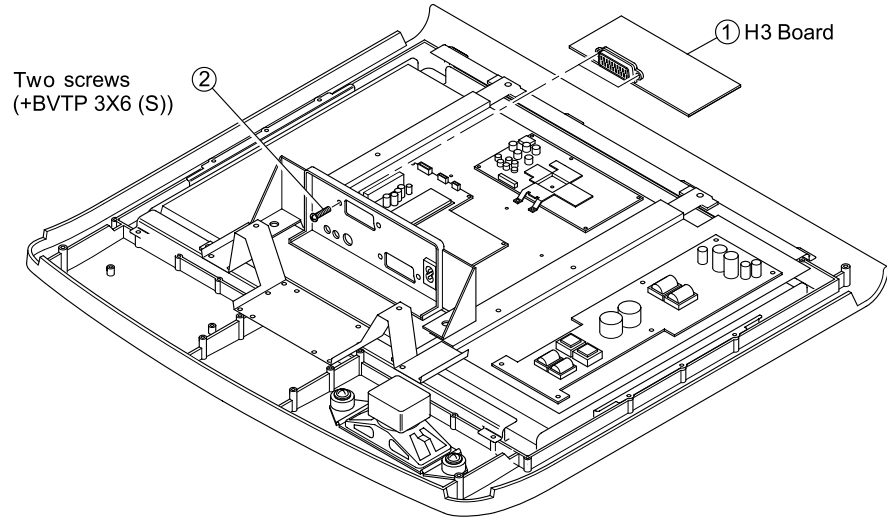

2-8. H5 BOARD REMOVAL

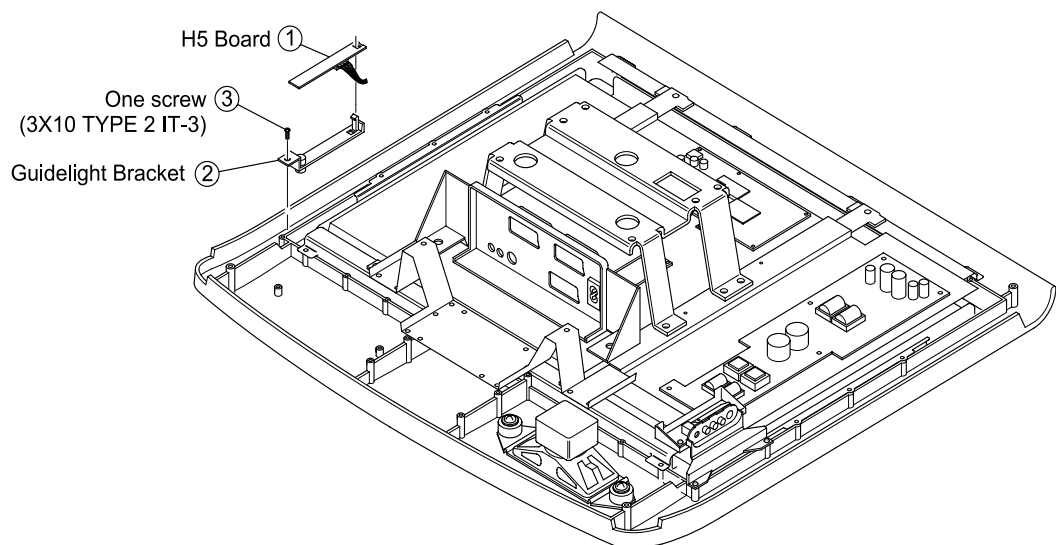

2-9. LCD BRACKET REMOVAL

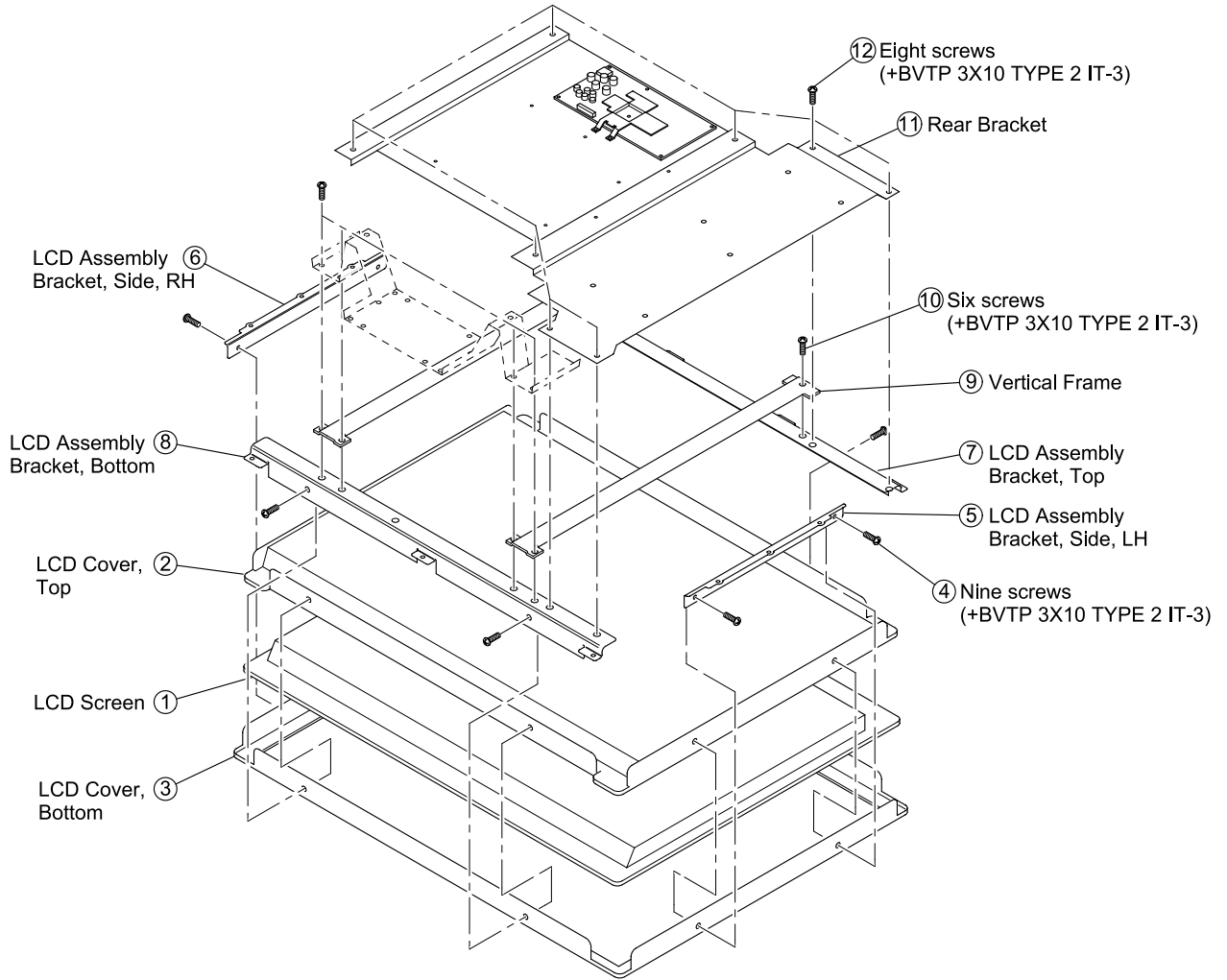

2-10. LCD ASSEMBLY REMOVAL

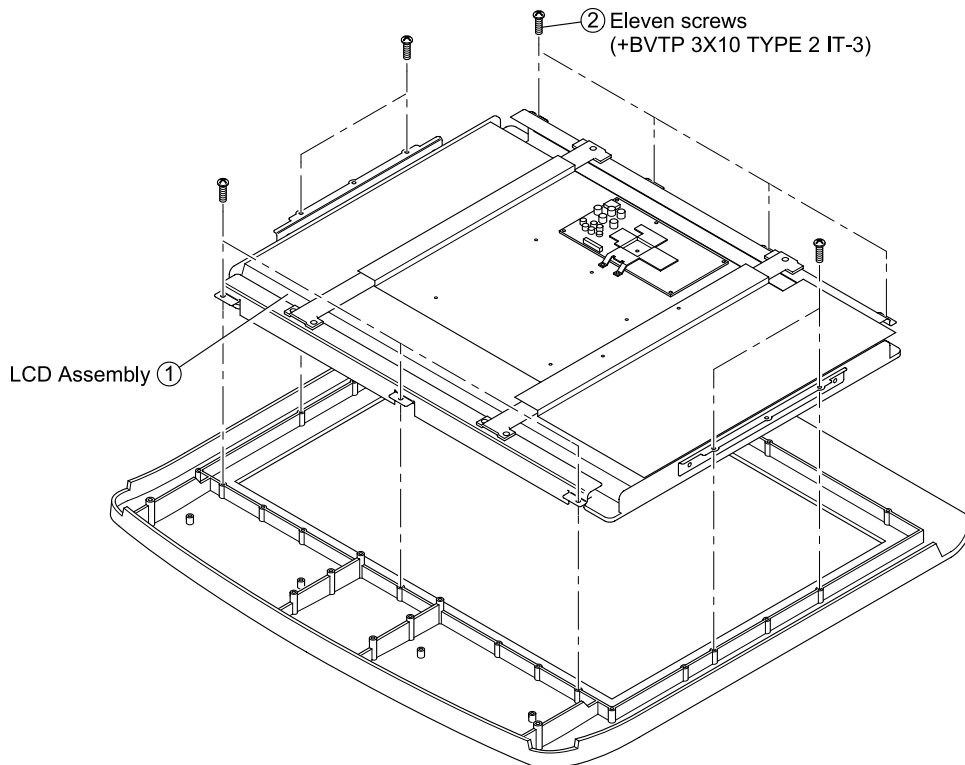

SECTION 3 SET-UP ADJUSTMENTS

3-1. Signal Adjustment

Service adjustments to this model can be performed using the supplied remote Commander RM-Y1108.

How to enter into the Service Mode

1. Turn on the power to the TV set and enter into the stand-by mode.
2. Press the following sequence of buttons on the Remote Commander.

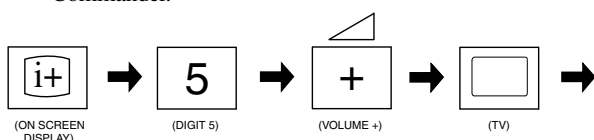

'TT—' will appear in the upper right corner of the screen. Other status information will also be displayed.

3. Press 'MENU' on the remote commander to obtain the following menu on the screen.

```

TRIDENT PANEL TV
CHROMA DECODER
BACKLIGHT
SOUND
IF ADJUST
SERVICE MENU
ERROR MENU

WA1 v0.29
FACTORY DATA FFh FFh
SERIAL NUMBER : 4294967295
    
```

4. Move to the corresponding adjustment item using the up or down arrow buttons on the Remote Commander.
5. Press the right arrow button to enter into the required menu item.
6. Press the 'Menu' button on the Remote Commander to quit the Service Mode when all adjustments have been completed.

Note :

- After carrying out the service adjustments, to prevent the customer accessing the 'Service Menu' switch the TV set OFF and then ON.

3-1-1.PAL auto adjustment (CVBS)

1. Select AV1 and input PAL signal. (PAL CVBS: CB 75%Y/75%C from signal generator).
2. Change the TV to Personal Mode and set the following registers.

Contrast - 90
Brightness - 50
Colour - 50

3. Set the TV in Service Mode (See above) and send "TT51" command.

3-1-2.PAL auto adjustment (RGB)

1. Select AV1 and input RGB signal. (PAL RGB: CB 100%Y/75%C from signal generator).
2. Change the TV to Personal Mode and set the following registers.

Contrast - 90
Brightness - 50
Colour - 50

3. Set the TV in Service Mode (See above) and send "TT52" command.

3-1-3.SECAM auto adjustment (CVBS)

1. Select AV1 and input SECAM signal. (SECAM CVBS: CB 75%Y/75%C from signal generator).
2. Change the TV to Personal Mode and set the following registers.

Contrast - 90
Brightness - 50
Colour - 50

3. Set the TV in Service Mode (See above) and send "TT53" command.

Note :

- While Auto adjustment is in process the RED LED is ON, till it finishes.

3-2. White Balance Adjustment

3-2-1. White Balance adjustment (H/L)

1. Select AV1.
2. Change the TV to Personal Mode and set the following registers.

Contrast - Max
Brightness - 50
Colour - 50
Backlight - Max

3. Input PAL CVBS 70 IRE Full Field Signal to AV1.
4. Enter the 'SERVICE MENU' using the cursor keys on the remote commander.
5. Adjust Highlight registers:

NORMAL_PAL_RD (R Drive)
NORMAL_PAL_BD (B Drive)

High light adjustment value (10500K-6MPCD)

	KLV-27HR3	range
x	0.2798	0.8JND
y	0.2823	
Y	-	N/A

3-2-2. White Balance adjustment (C/O)

1. Select AV1.
2. Change the TV to Personal Mode and set the following registers.

Contrast - Max
 Brightness - 50
 Colour - 50
 Backlight - Max

3. Input PAL CVBS 20 IRE Full Field Signal to AV1.
4. Enter the 'SERVICE MENU' using the cursor keys on the remote commander.
5. Adjust CutOff registers:

NORMAL_PAL_RC (R cutoff)
 NORMAL_PAL_BC (B cutoff)

Low light (Cut Off) adjustment value (10500K-6MPCD)

	KLV-27HR3	range
x	0.2798	0.8JND
y	0.2823	
Y	-	N/A

3-2-3. Secam White Balance adjustment (C/O)

1. Select AV1.
2. Change the TV to Personal Mode and set the following registers.

Contrast - Max
 Brightness - 50
 Colour - 50
 Backlight - Max

3. Input SECAM CVBS 20 IRE Full Field Signal to AV1.
4. Enter the 'SERVICE MENU' using the cursor keys on the remote commander.
5. Adjust CutOff registers:

SECAM_OFFSET_RC (R cutoff)
 SECAM_OFFSET_BC (B cutoff)

Low light (Cut Off) adjustment value (10500K-6MPCD)

	KLV-27HR3	range
x	0.2760	0.8JND
y	0.2710	
Y	-	N/A

3-3. TEST TEST MODE

Test Test Mode is available in Service Mode, OSD 'TT' appears. The functions described below are available by selecting the two numbers. To release 'Test Test mode', press 00 or switch the TV set into Stand-by mode.

00	'TT' mode off
01	Picture maximum
02	Picture minimum
03	Set Volume to 35%
04	Set Volume to 50%
05	Set Volume to 65%
06	Set Volume to 80%
07	Ageing mode
08	Shipping Condition
16	Picture level 50%
19	Factory Mode toggle (on/off)
25	AEP Destination
27	CBA mode toggle (ON/OFF)
41	Re-initialise NVM
43	Select Dual Sound A
44	Select Dual Sound B
45	Select Dual Sound Mono
46	Select Dual Sound Stereo
48	Set NVM as non-virgin
49	Set NVM as virgin
51	LCD Auto adjustment Pal
52	LCD Auto adjustment RGB
53	LCD Auto adjustment Secam
63	AM from baseband (AFRIC dem) or from RF (MSP dem)
67	MSP Auto Carrier Mute function enable/disable
75	Balance to center position
76	Volume maximum
77	Volume minimum
78	Balance full left
79	Balance full right
81	Set 14:9 zoom mode
82	Set Smart zoom mode
83	Set Wide mode
84	Set Zoom mode
85	Set 4:3 mode
87	Local keys test
93	Set 20" settings
94	Set 17" settings
95	Set 30" settings
96	Set 27" settings
97	Freeze key
99	Display Error and Working Time menu

4-1. BLOCK DIAGRAMS (1)

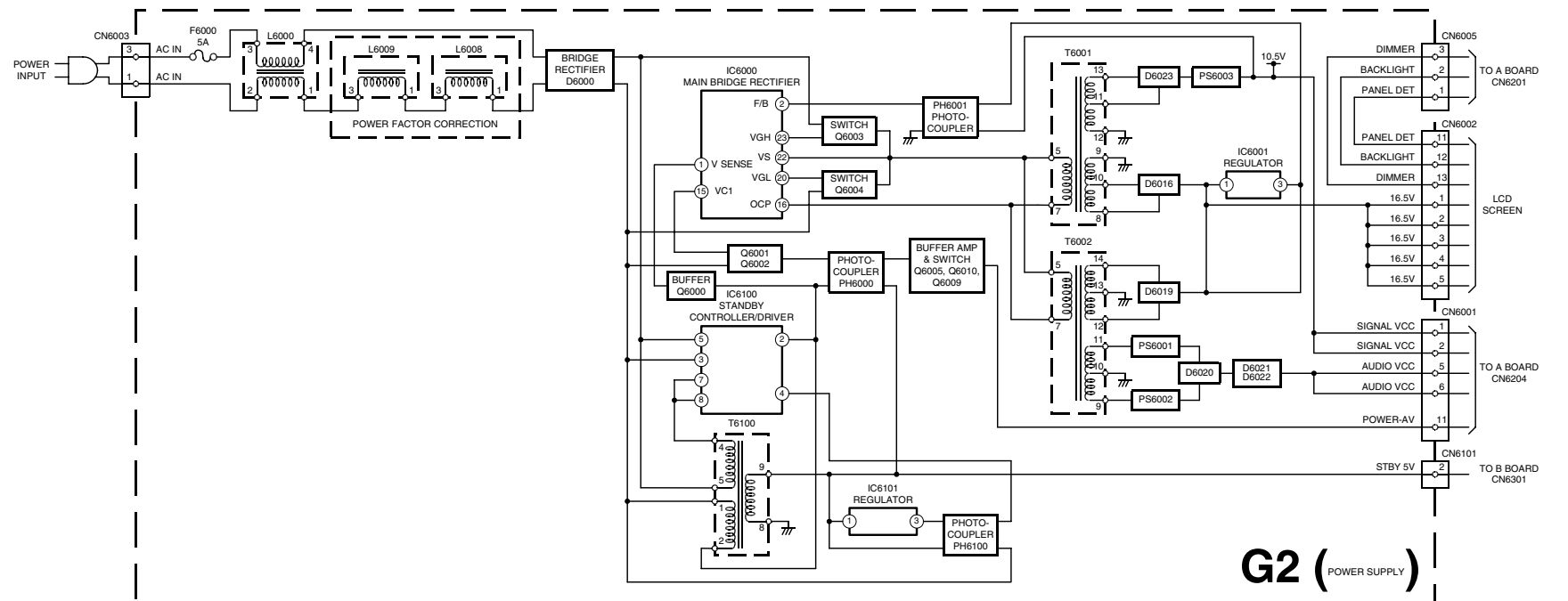
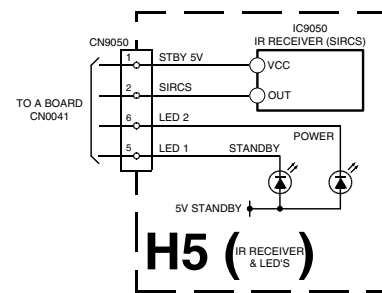
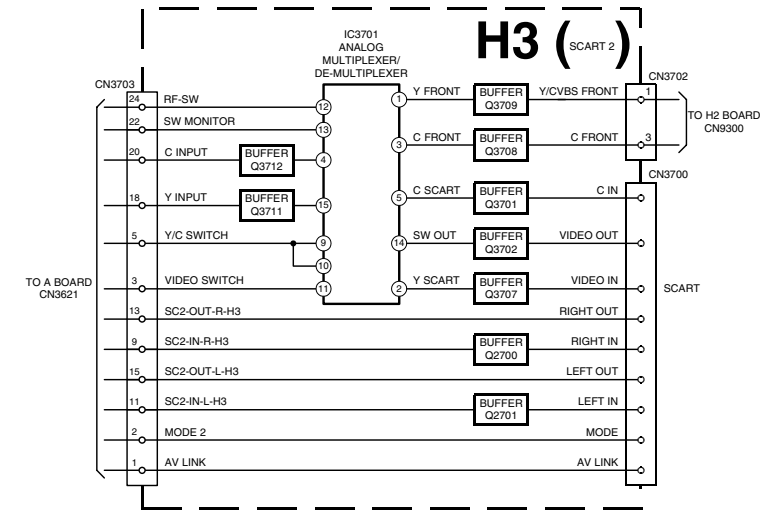
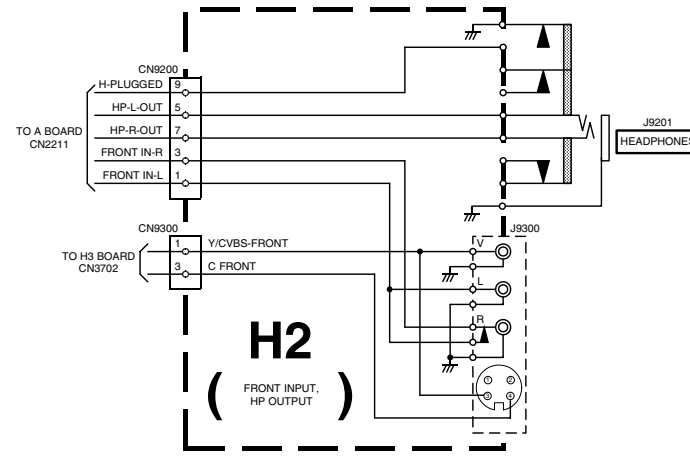
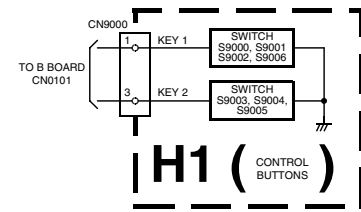

4-1. BLOCK DIAGRAMS (2)

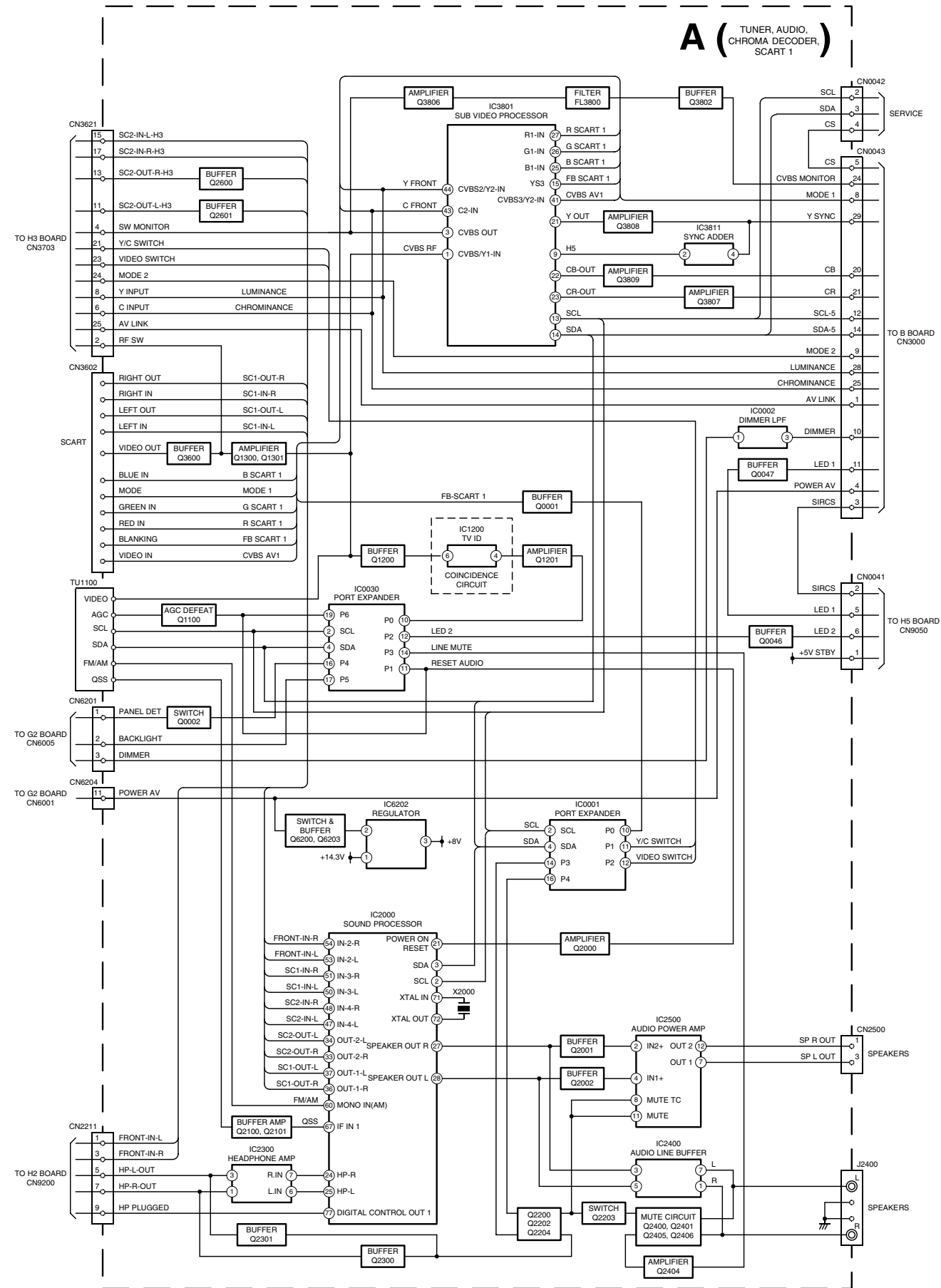

4-2. CIRCUIT BOARD LOCATION

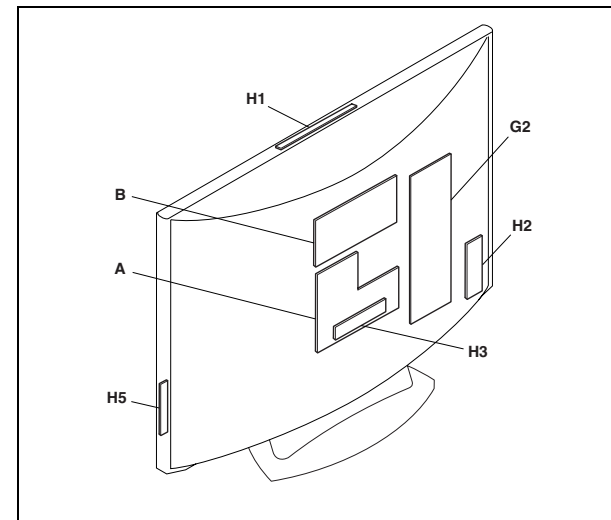

4-3. SCHEMATIC DIAGRAMS AND PRINTED WIRING BOARDS

Note :

- All capacitors are in μF unless otherwise noted.
- pF : μF 50WV or less are not indicated except for electrolytic types.
- Indication of resistance, which does not have one for rating electrical power, is as follows.

Pitch : 5mm
Electrical power rating : 1/4W

- Chip resistors are 1/10W
- All resistors are in ohms.
k = 1000 ohms, M = 1000,000 ohms
- : nonflammable resistor.
- : fusible resistor.
- : internal component.
- : panel designation or adjustment for repair.
- All variable and adjustable resistors have characteristic curve B, unless otherwise noted.
- All voltages are in Volts.
- Readings are taken with a 10Mohm digital multimeter.
- Readings are taken with a color bar input signal.
- Voltage variations may be noted due to normal production tolerances.

- : B + bus.
- : B - bus.
- : RF signal path.
- : earth - ground.
- : earth - chassis.

Reference Information

RESISTOR	RN	: METAL FILM
	RC	: SOLID
	FPRD	: NON FLAMMABLE CARBON
	FUSE	: NON FLAMMABLE FUSIBLE
	RS	: NON FLAMMABLE METAL OXIDE
	RB	: NON FLAMMABLE CEMENT
	RW	: NON FLAMMABLE WIREWOUND
		: ADJUSTMENT RESISTOR
COIL	LF-8L	: MICRO INDUCTOR
CAPACITOR	TA	: TANTALUM
	PS	: STYROL
	PP	: POLYPROPYLENE
	PT	: MYLAR
	MPS	: METALIZED POLYESTER
	MPP	: METALIZED POLYPROPYLENE
	ALB	: BIPOLAR
	ALT	: HIGH TEMPERATURE
	ALR	: HIGH RIPPLE

Note : The components identified by shading and marked Δ are critical for safety. Replace only with the part numbers specified in the parts list.

Note : Les composants identifiés par une trame et par une marque Δ sont d'une importance critique pour la sécurité. Ne les remplacer que par des pièces de numéro spécifié.

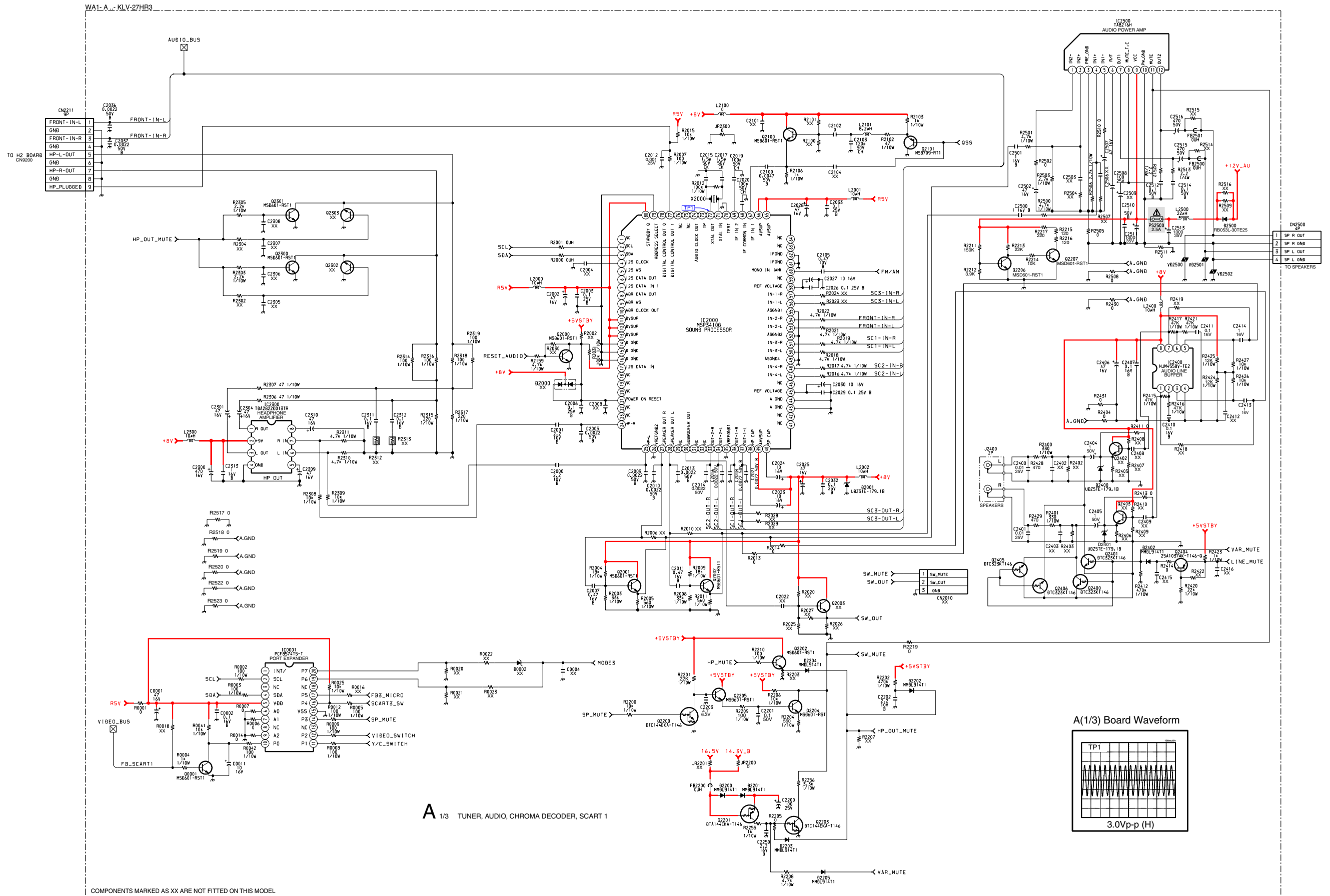

COMPONENTS MARKED AS XX ARE NOT FITTED ON THIS MODEL

A 1/3 TUNER, AUDIO, CHROMA DECODER, SCART 1

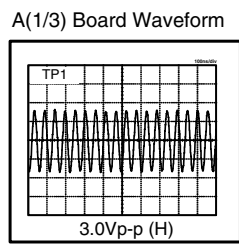

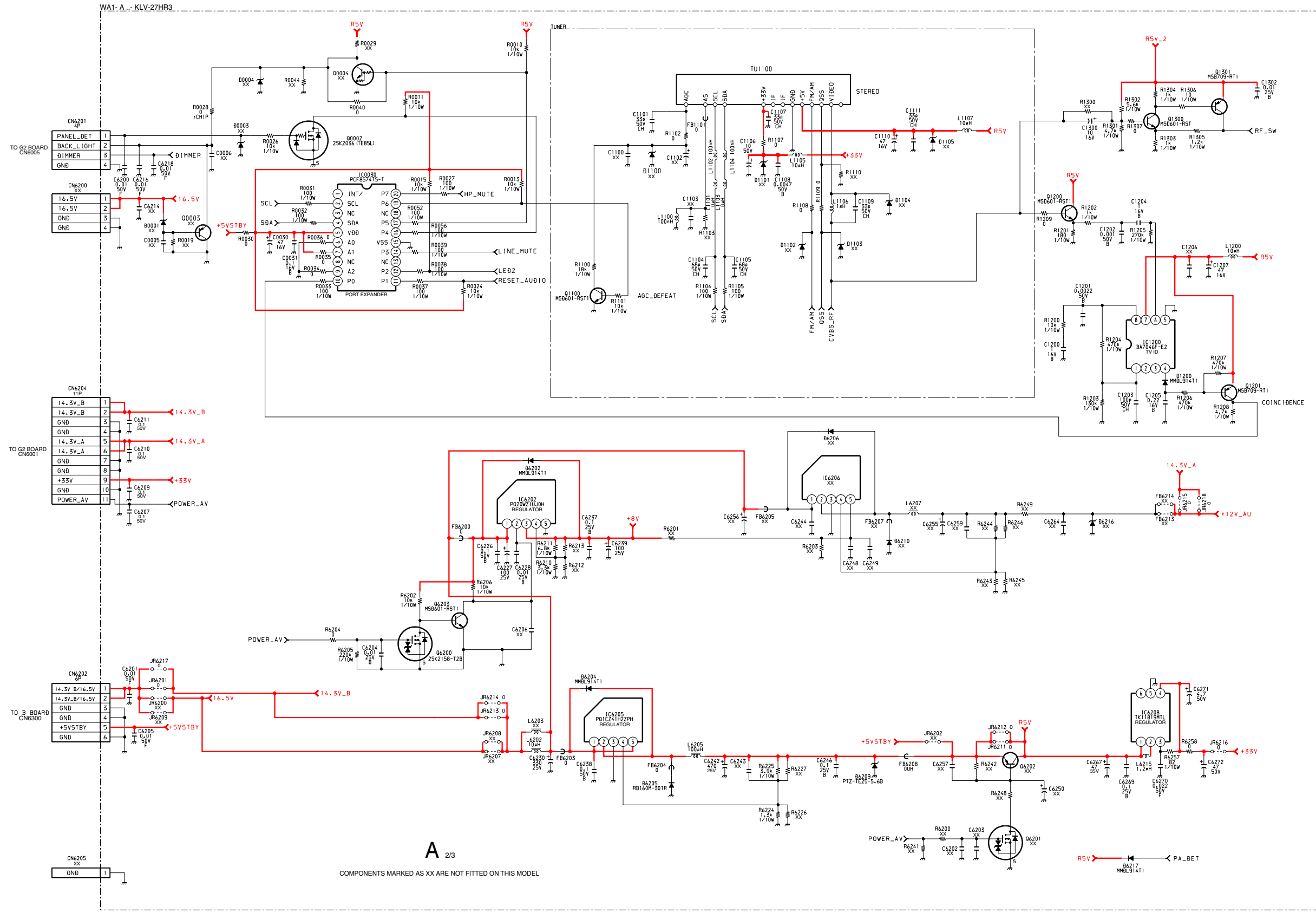

A 2/3
COMPONENTS MARKED AS XX ARE NOT FITTED ON THIS MODEL

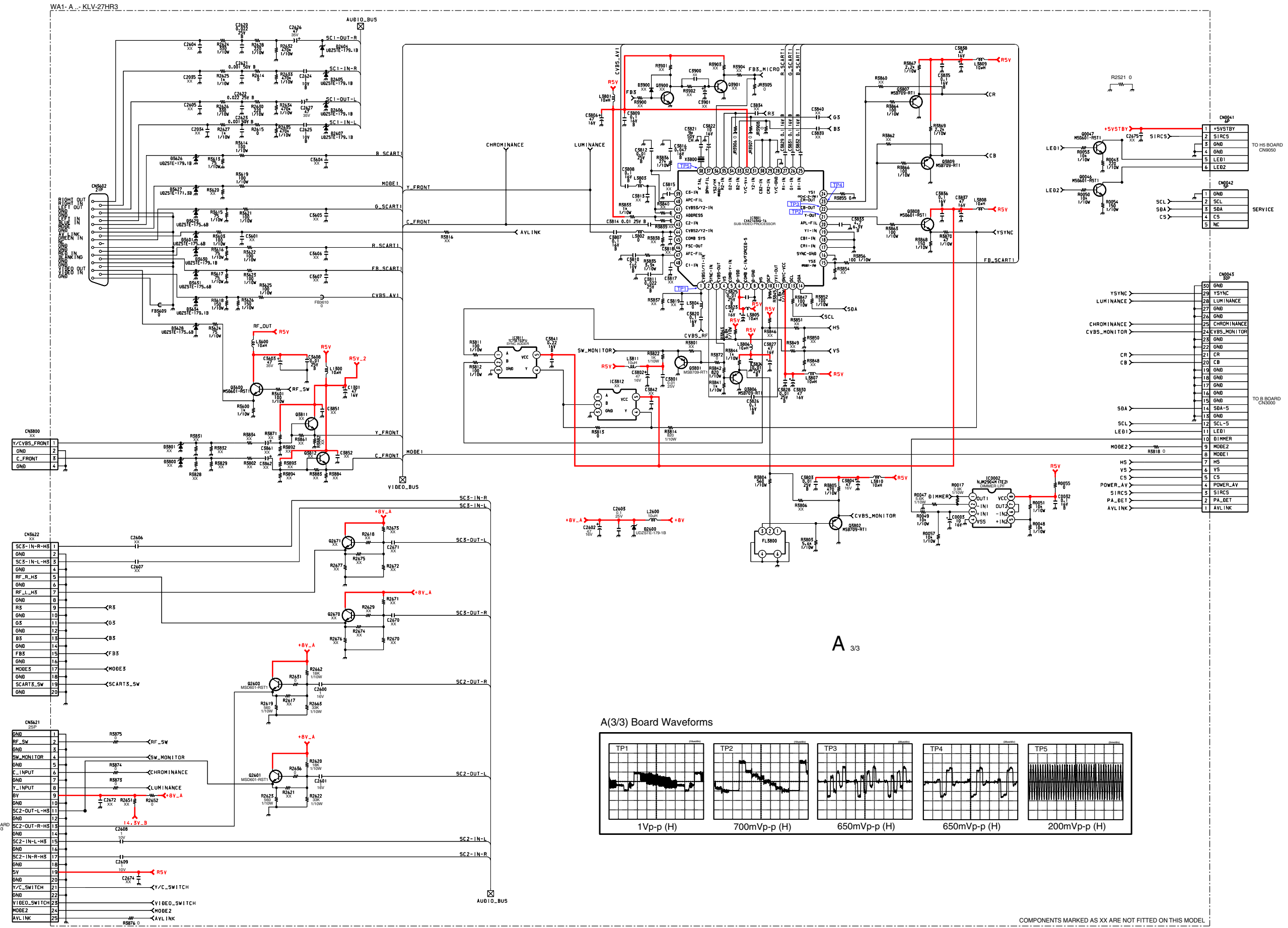

A(3/3) Board Waveforms

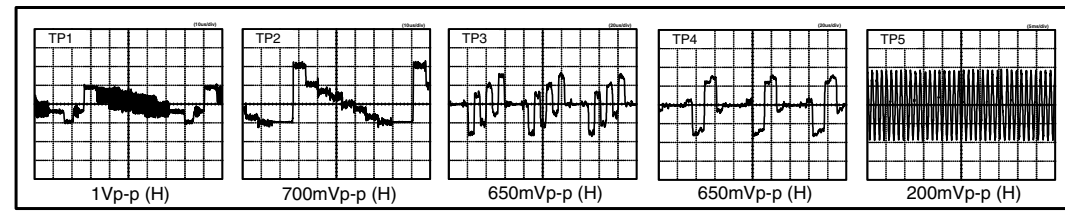

COMPONENTS MARKED AS XX ARE NOT FITTED ON THIS MODEL

~ A Printed Wiring Board Conductor Side A ~

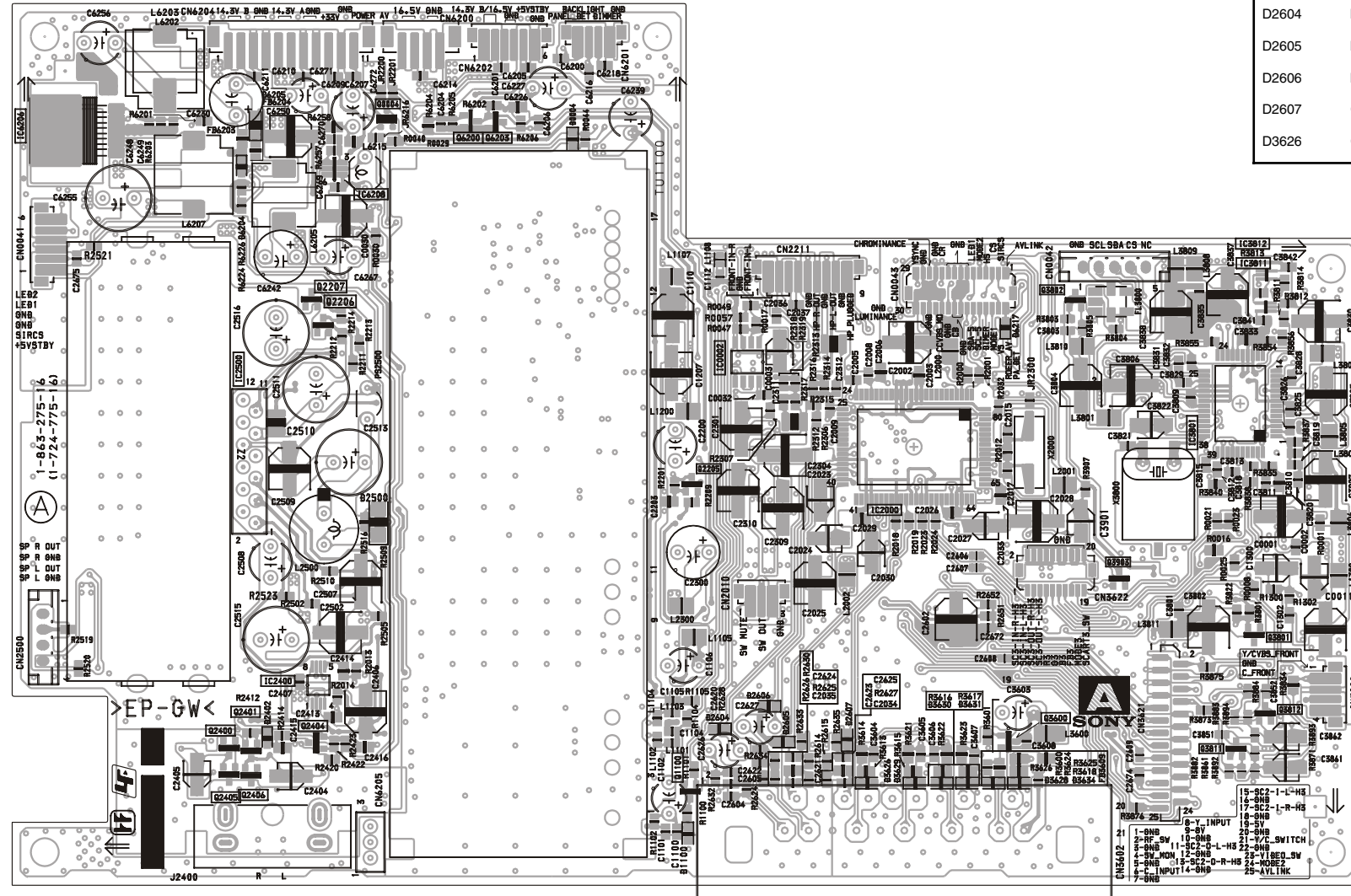

~ A Board Semiconductor Location Table Side A ~

DIODE	D3628	H - 6	D6217	H - 3	IC3811	I - 3	Q2404	C - 6	
D2402	C - 6	D3629	G - 6	IC		IC6208	D - 3	Q2405	C - 6
D2604	F - 6	D3630	G - 6	IC0002	F - 4	TRANSISTOR			
D2605	F - 6	D3631	G - 6	IC2000	G - 4	Q1100	F - 6	Q2406	C - 6
D2606	F - 6	D3634	H - 6	IC2400	C - 6	Q2205	F - 4	Q3600	H - 6
D2607	G - 6	D6204	C - 3	IC2500	C - 4	Q2400	C - 6	Q3801	I - 5
D3626	G - 6	D6205	C - 2	IC3801	I - 4	Q2401	C - 6	Q6200	D - 2
								Q6203	E - 2

~ A Board Semiconductor Voltage Table ~

Ref	(e)(s)	(b)(g)	(c)(d)	Ref	(e)(s)	(b)(g)	(c)(d)	Ref	(e)(s)	(b)(g)	(c)(d)
Q1100	0	0	4.4	Q2404	0.6	0	0.6	Q3801	2.1	1.4	0
Q2205	0.3	0	5.0	Q2405	0	0.3	0	Q3802	2.0	1.3	0
Q2400	0	0.3	0	Q2406	0	0.3	0	Q6200	0	3.2	0
Q2401	0	0.3	0	Q3600	2.5	3.1	5.1	Q6203	0	0	7.1

~ A Board IC Voltage Table ~

Ref No	Pin No	Volts (V)	Ref No	Pin No	Volts (V)	Ref No	Pin No	Volts (V)	Ref No	Pin No	Volts (V)	Ref No	Pin No	Volts (V)	Ref No	Pin No	Volts (V)	Ref No	Pin No	Volts (V)	Ref No	Pin No	Volts (V)					
IC0002	1	3.1	IC2000	13	5.0	IC2000	34	3.8	IC2000	53	3.7	IC2400	72	2.3	IC3801	1	1.5	IC3801	18	0	IC3801	30	0	IC3811	42	5.0		
	2	1.6		14	0		35	0		54	3.7		77	0		2	1.5		7	2.6		19	0		31	0	43	1.7
	3	1.6		15	0		36	3.7		56	3.7		79	0		3	0		8	0		20	2.4		32	5.0	44	2.0
	4	0		16	0		37	3.7		57	3.7		80	5.0		5	1.5		9	0.3		21	1.7		33	2.5	45	5.0
	5	2.5		21	4.7		38	7.2		58	2.6		1	4.1		7	13.5		10	0.8		22	1.8		34	2.5	46	2.3
	6	2.5		24	0		39	8.1		60	3.7		2	4.1		9	28.8		11	2.5		23	1.8		35	2.5	47	3.8
	7	2.5		25	0		40	7.1		65	5.0		3	4.1		11	2.9		12	5.1		24	0		36	0	48	1.8
	8	5.1		26	0		45	3.7		66	5.0		4	0		1	2.4		13	3.7		25	2.5		37	1.1	1	0
IC2000	2	3.5	27	0.2	47	3.7	67	1.5	5	4.1	2	2.1	14	3.7	26	2.5	38	4.0	2	0								
	3	3.7	28	0.2	48	3.7	68	1.5	6	4.1	3	1.4	15	0	27	2.5	39	1.7	3	0.3								
	11	5.0	30	0.2	50	3.7	70	0	7	4.1	4	0.2	16	0	28	0	40	3.1	4	4.4								
	12	5.0	33	3.8	51	3.7	71	2.4	8	8.1	5	2.0	17	0	29	0	41	2.0	5	5.0								

~ A Printed Wiring Board Conductor Side B ~

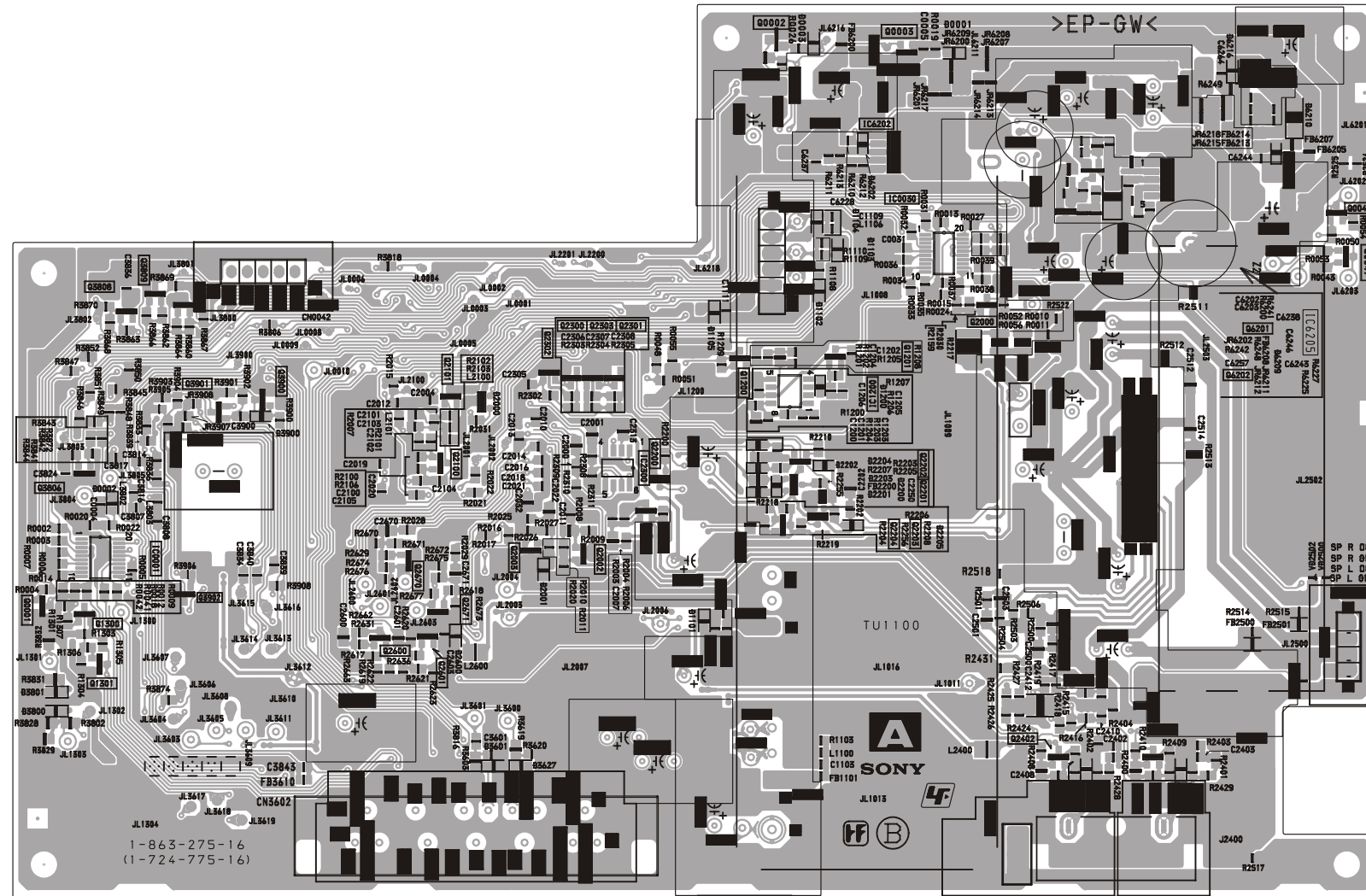

~ A Board Semiconductor Location Table Side B ~

DIODE		D2201	G - 4	D2600	D - 5	IC		IC6202	G - 2	Q0046	J - 3	Q1301	B - 6	Q2200	E - 4	Q2300	E - 4	Q3806	B - 4
D0002	B - 5	D2202	G - 4	D3601	D - 6	IC0001	B - 5	IC6205	J - 4	Q0047	J - 3	Q2000	H - 3	Q2201	G - 4	Q2301	E - 4	Q3808	B - 3
D1200	G - 4	D2203	G - 4	D3627	E - 6	IC0030	G - 3	TRANSISTOR		Q1200	F - 4	Q2002	E - 5	Q2202	G - 4	Q2600	D - 5	Q3809	B - 3
D2001	E - 5	D2204	G - 4	D6202	G - 3	IC1200	G - 4	Q0001	B - 5	Q1201	G - 4	Q2100	D - 4	Q2203	G - 5	Q2670	D - 5	Q3900	C - 4
D2200	G - 4	D2205	G - 5	D6209	I - 4	IC2300	E - 4	Q0002	F - 2	Q1300	B - 5	Q2101	D - 4	Q2204	G - 5	Q2671	D - 5	Q3901	C - 4

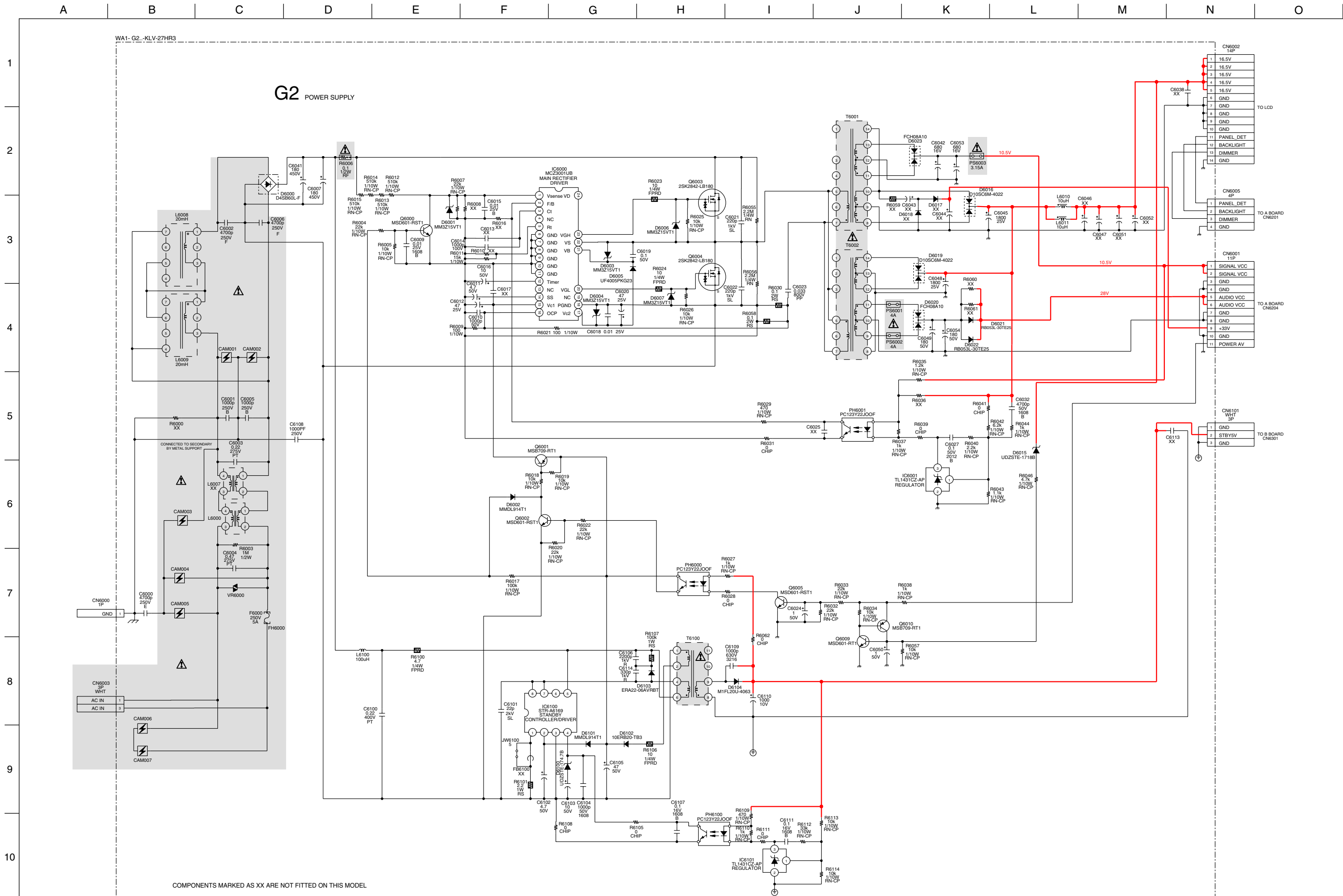

COMPONENTS MARKED AS XX ARE NOT FITTED ON THIS MODEL

~ G2 Board Schematic Diagram [Power Supply] ~

A B C D E F G H I J K L M N O

~ G2 Printed Wiring Board Conductor Side A ~

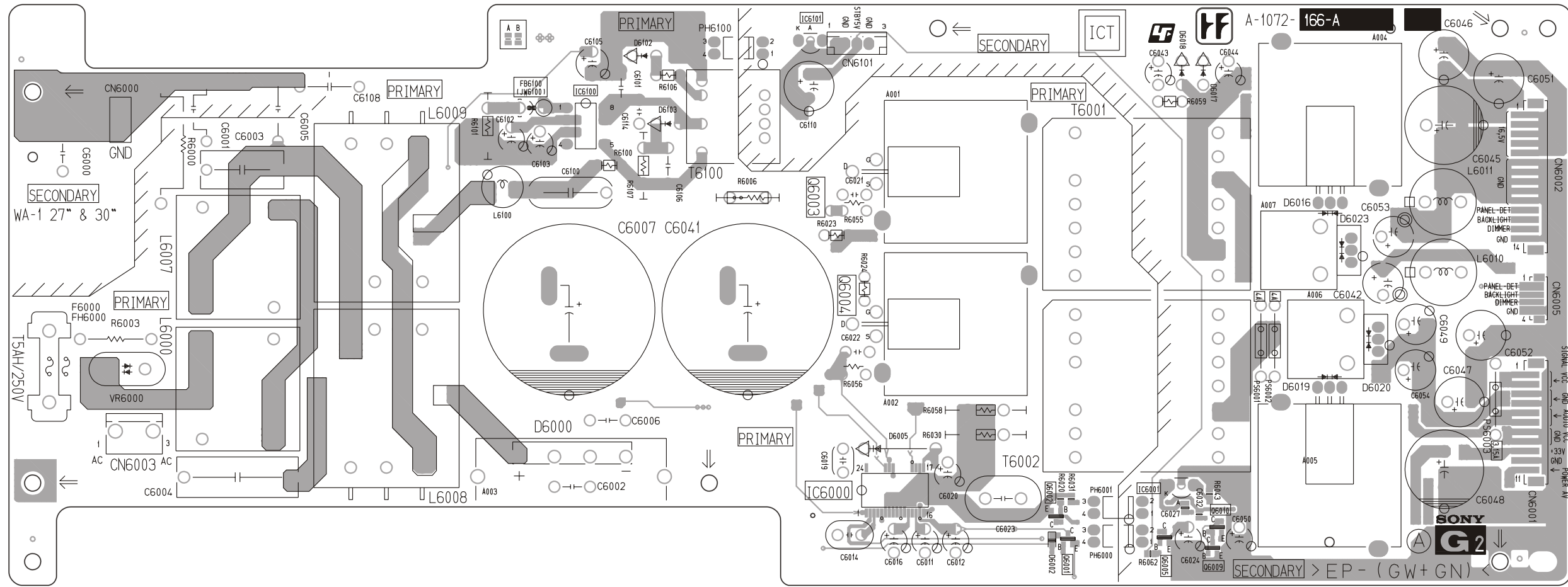

~ G2 Board IC Voltage Table ~

Ref No	Pin No	Volts (V)	Ref No	Pin No	Volts (V)
IC6000	1	-0.3	IC6001	24	-0.3
	2	-0.3		1	2.5
	3	-0.3		3	7.5
	5	-0.3	IC6100	1	-0.3
	12	-0.3		2	-0.3
	14	-0.3		3	-0.3
	15	-0.3		4	-0.3
	16	-0.3		5	0.3
	17	-0.3	7	0.3	
	20	-0.3	8	0.3	
21	-0.3	IC6101	1	2.5	
23	-0.3		3	3.2	

~ G2 Board Semiconductor Voltage Table ~

Ref	(e)(s)	(b)(g)	(c)(d)	Ref	(e)(s)	(b)(g)	(c)(d)	Ref	(e)(s)	(b)(g)	(c)(d)	Ref	(e)(s)	(b)(g)	(c)(d)
Q6000	0	0	0	Q6002	-0.3	-0.3	-0.3	Q6004	-0.3	-0.3	-0.3	Q6009	0	0	3.1
Q6001	-0.3	-0.3	-0.3	Q6003	0.3	0.3	0.3	Q6005	0	0.6	0	Q6010	3.1	3.1	0

~ G2 Board Semiconductor Location Table Side A ~

DIODE	D6005	H - 5	D6020	L - 4	D6103	F - 2	IC6001	J - 5	TRANSISTOR	Q6003	H - 3	Q6009	K - 5	
D6000	E - 5	D6016	L - 3	D6023	L - 3	IC	IC6100	F - 2	Q6001	J - 5	Q6004	H - 4	Q6010	K - 5
D6002	J - 5	D6019	L - 4	D6102	F - 1		IC6000	H - 5	IC6101	G - 1	Q6002	J - 5	Q6005	J - 5

A B C D E F G H I J K L M N O

~ G2 Printed Wiring Board Conductor Side B ~

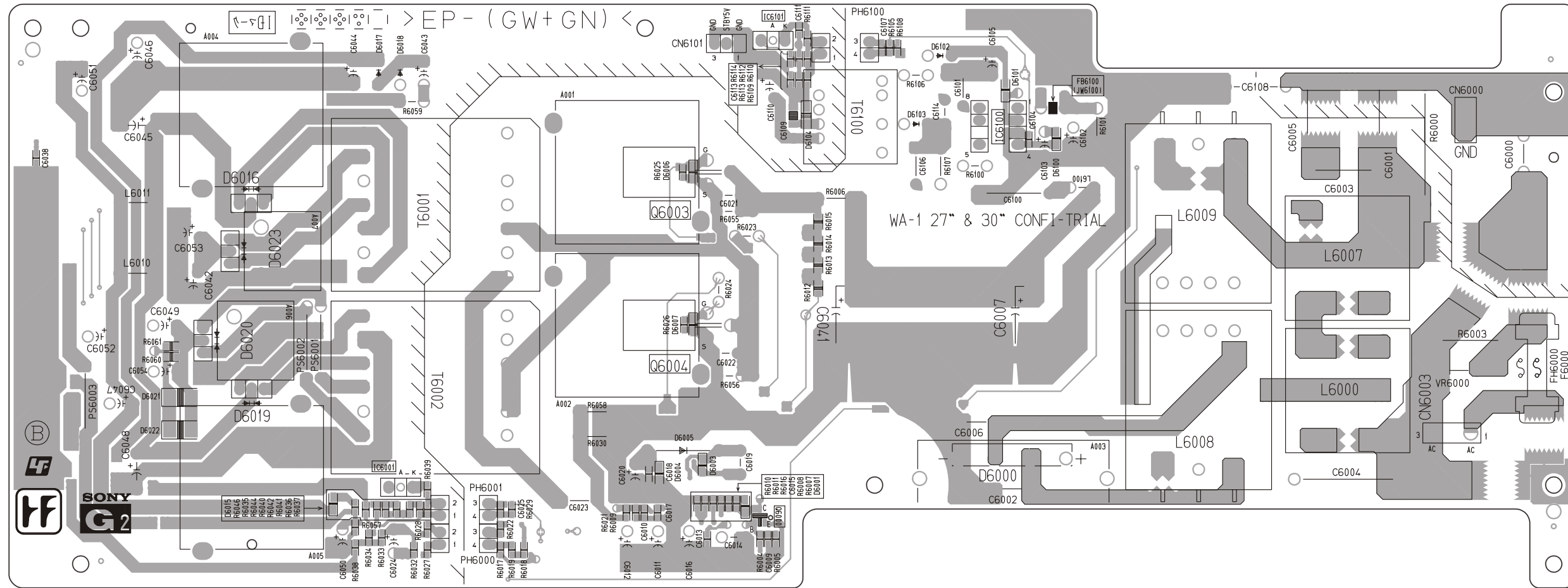

~ G2 Board Semiconductor Location Table Side B ~

DIODE	D6019	C - 4	D6104	H - 2
D6000	I - 5	D6020	C - 4	IC
D6001	G - 5	D6021	B - 4	IC6001
D6003	G - 5	D6022	B - 5	IC6100
D6004	F - 5	D6023	C - 3	IC6101
D6005	F - 5	D6100	J - 2	TRANSISTOR
D6006	F - 2	D6101	I - 2	Q6000
D6007	F - 4	D6102	I - 1	Q6003
D6015	D - 5	D6103	H - 2	Q6004

11

~ H1 Board Schematic Diagram [Control Buttons] ~

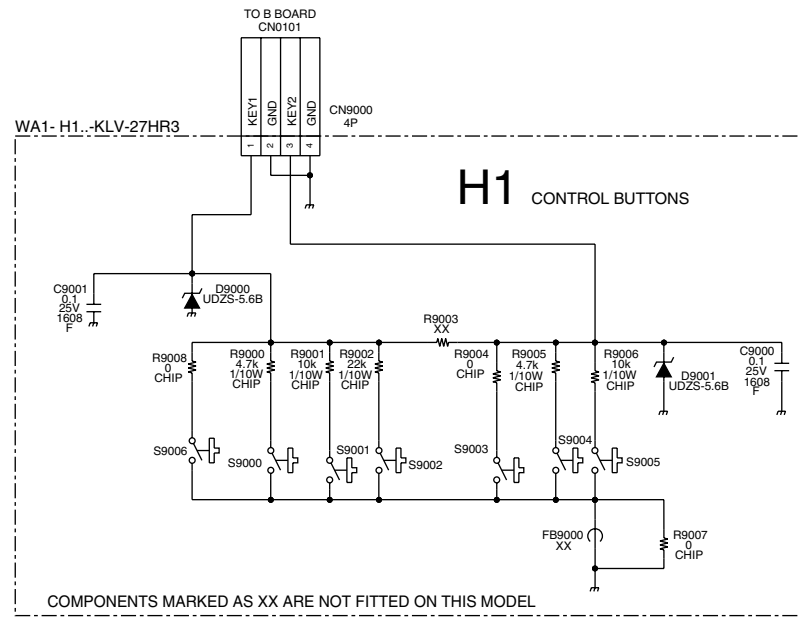

~ H2 Board Schematic Diagram [Front Input, HP Output] ~

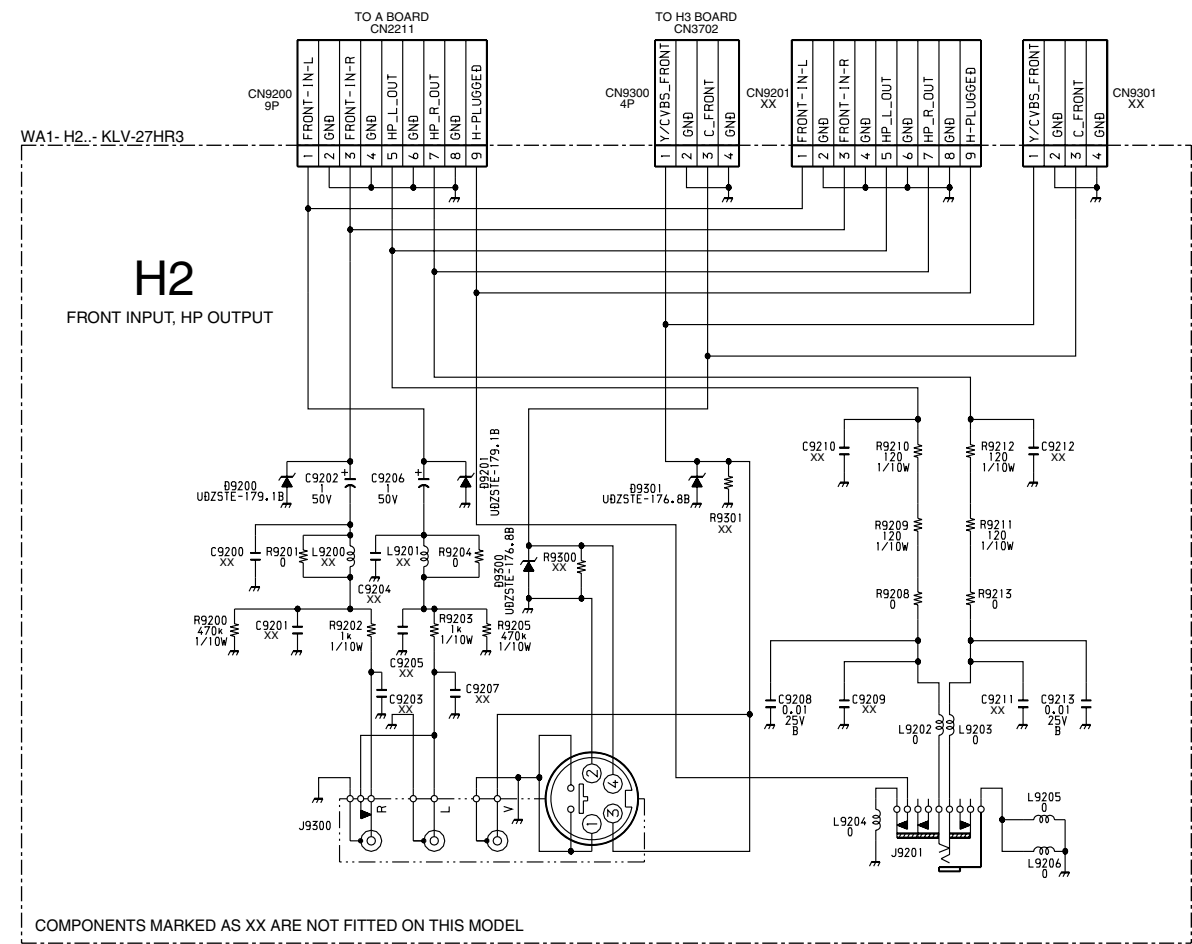

~ H5 Board Schematic Diagram [IR Receiver & LED's] ~

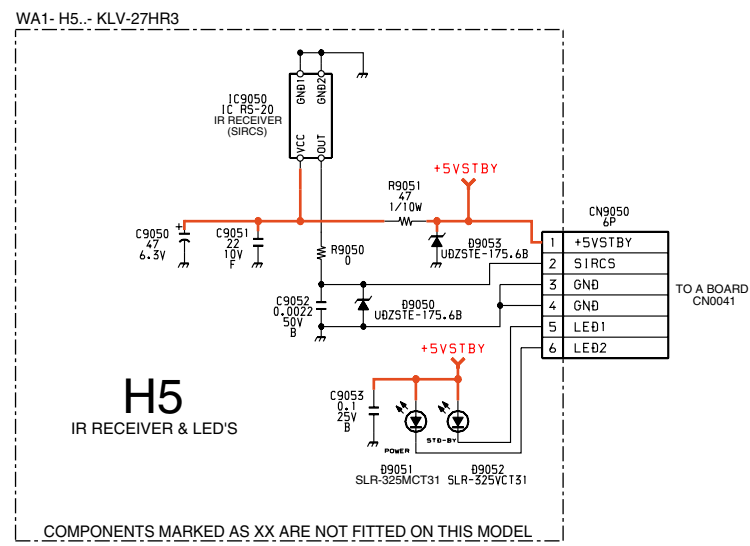

WA1-H3.- KLV-27HR3

H3 SCART 2

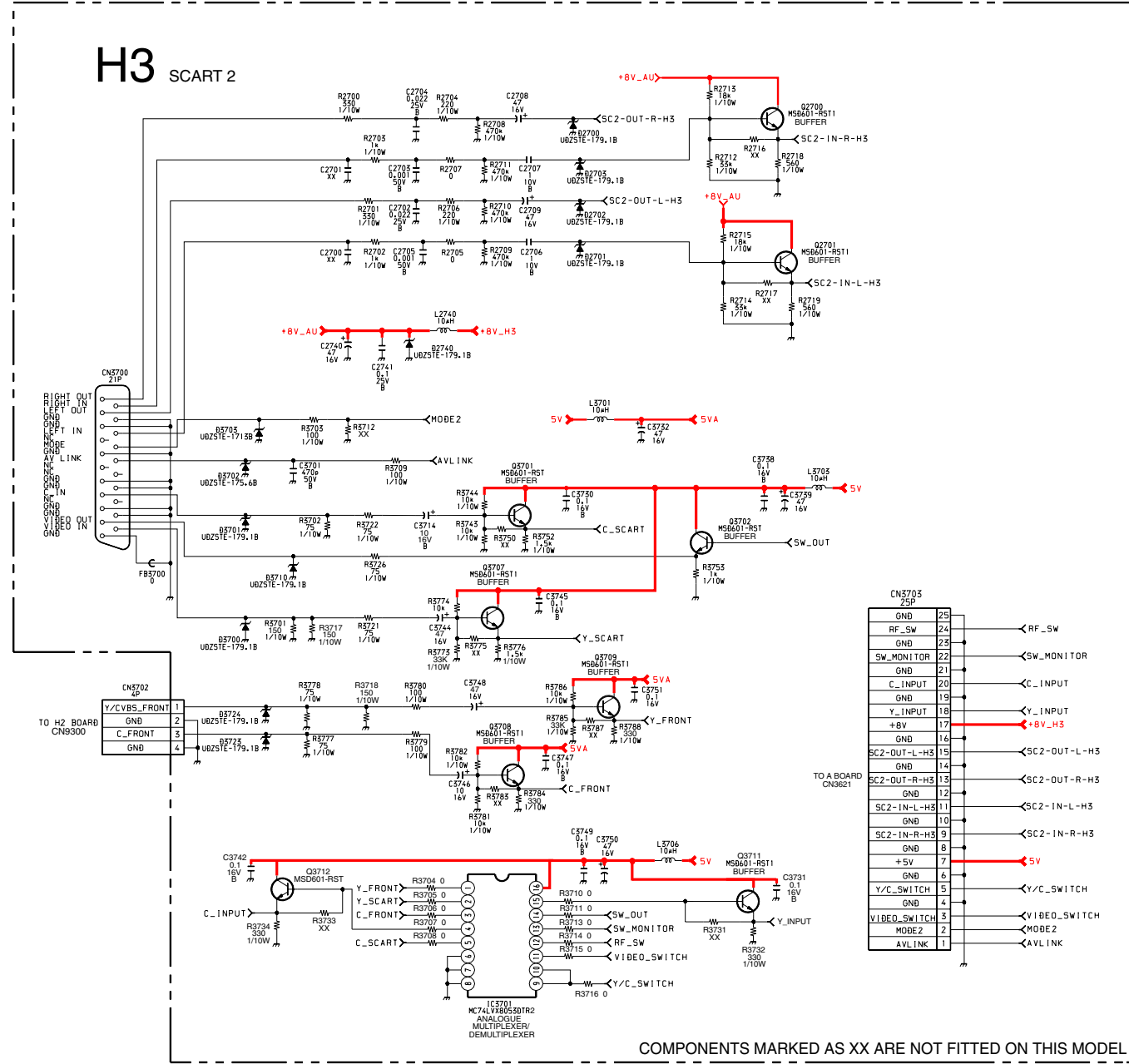

COMPONENTS MARKED AS XX ARE NOT FITTED ON THIS MODEL

~ H3 Board Schematic Diagram [Scart 2] ~

4-4. SEMICONDUCTORS

10ERB20-TB3
ERA22-08

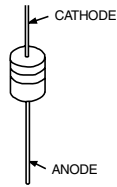

M1FL20U-4063
RB160M-30TR

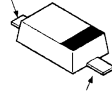

PCF8574TS-T

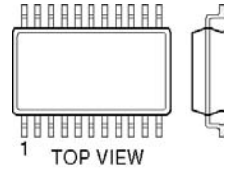

2SA1037AK-T146
2SK2036(TE85L)
2SK2158-T2B
DTA144EKA-T146
DTC144EKA
DTC323TK
MSB709-RT1
MSD601-RST1
MSD601-RT1

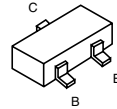

MC74HC4053AFEL

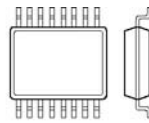

PQ1CZ41H2ZPH
PQ20WZ1UJ00H

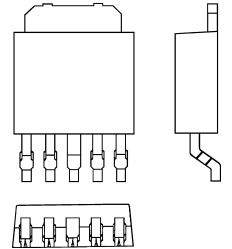

MC74LVX8053DTR2

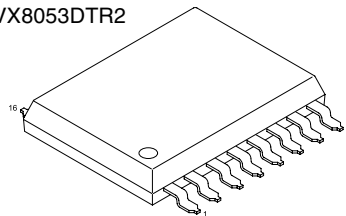

BA7046F
MM1115XFBE

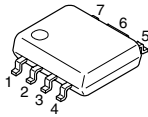

MCZ3001UB

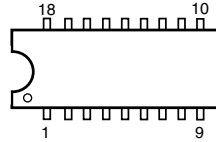

PTZ-TE25-30B
RB053L-30TE25

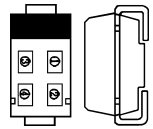

CXA2163AQ-T6

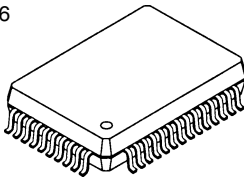

RS-20

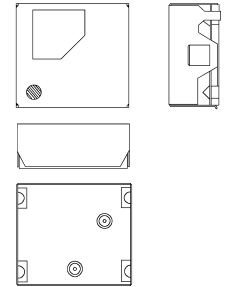

D10SC6M-4022

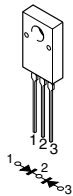

DTZ-TT11-6.8B
MMDL914T1
MM3Z15VT1
UDZSTE-1713B
UDZSTE-1718B
UDZSTE-174.7B
UDZSTE-175.6B
UDZSTE-176.2B
UDZSTE-179.1B

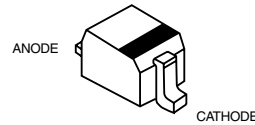

S2K2842-LB180

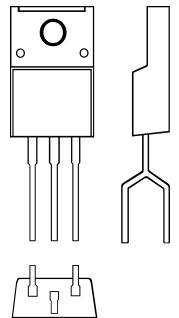

D4SBS60L

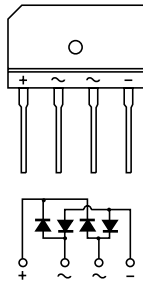

MSP3410G-QA-C12-0001

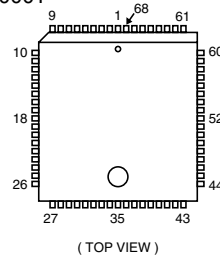

SI2301DS-T1

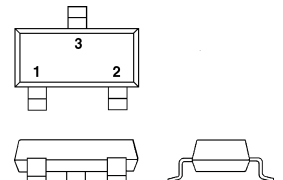

FCH08A10

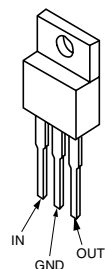

NJM4558V-TE2

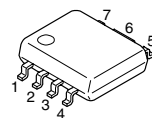

STR-A6169

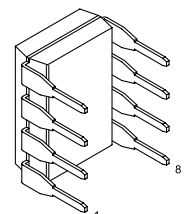

TA8216H

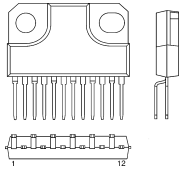

TC7SET02FU(TE85R)

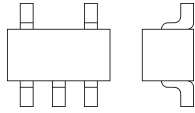

TDA2822D013TR

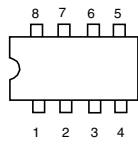

TL1431CZ-AP

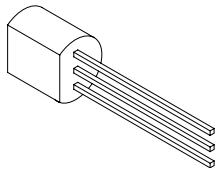

UF4005PKG23

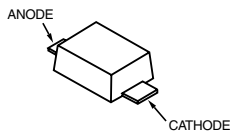

SECTION 5 EXPLODED VIEWS

NOTE :

- Items with no part number and no description are not stocked because they are seldom required for routine service.
- The construction parts of an assembled part are indicated with a collation number in the remarks column.
- Items marked “*” are not stocked since they are seldom required for routine service. Some delay should be anticipated when ordering these items.

5-1. FRONT CABINET ASSY

m 4-058-870-01 SCREW, (4X16) W (+) P TAPPING

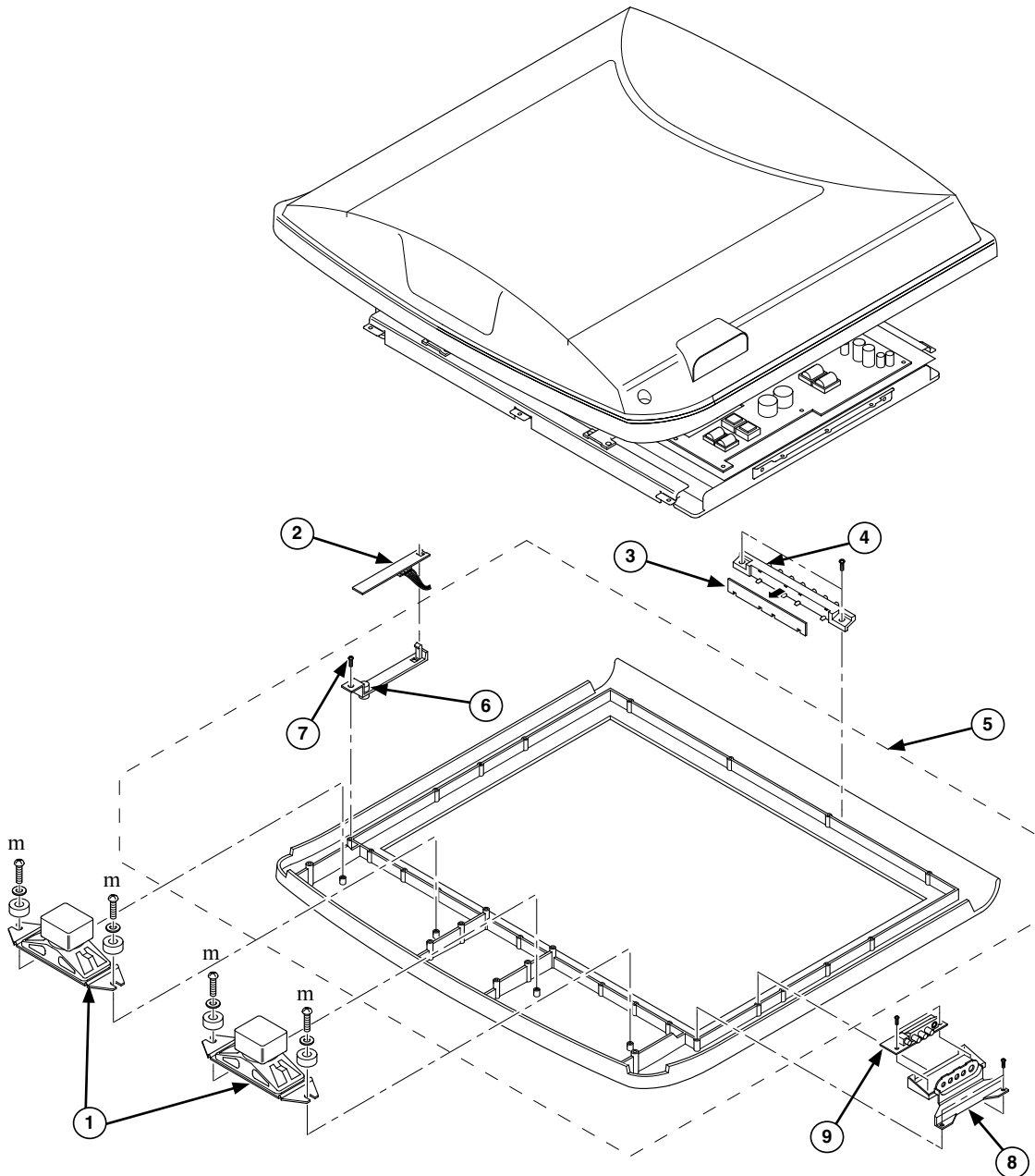

REF.NO.	PART.NO	DESCRIPTION	REMARK	REF.NO.	PART.NO	DESCRIPTION	REMARK
1	1-826-042-11	LOUDSPEAKER (5X15CM)		6	2-349-912-01	GUIDE LIGHT (PAINTED) BLACK	
2	*A-1057-434-A	H5 BOARD, COMPLETE			2-178-831-01	GUIDE LIGHT (PAINTED) SILVER	
3	*A-1072-345-A	H1 BOARD, COMPLETE		7	7-685-648-79	SCREW +BVTP 3X12 TYPE2 IT-3	
4	2-021-161-01	BUTTON, MULTI		8	*2-178-821-01	SIDE TERMINAL BRACKET	
5	X-2024-916-1	FRONT CABINET ASSY(27) BLACK	6, 7	9	*A-1068-281-A	H2 BOARD, COMPLETE	
	X-2024-912-1	FRONT CABINET ASSY(27) SILVER	6, 7				

5-2. REAR COVER, REAR CABINET ASSY, STAND ASSY AND CHASSIS

- l 7-685-881-09 SCREW +PSW 4X8
- o 7-685-660-79 SCREW +PSW 4X10
- : 7-685-648-79 SCREW +BVTP 3X12 TYPE2 IT-3
- n 7-685-663-79 SCREW +BVTP 4X16 TYPE2 IT-3
- s 7-685-871-01 SCREW +BVTT 3X6 (S)

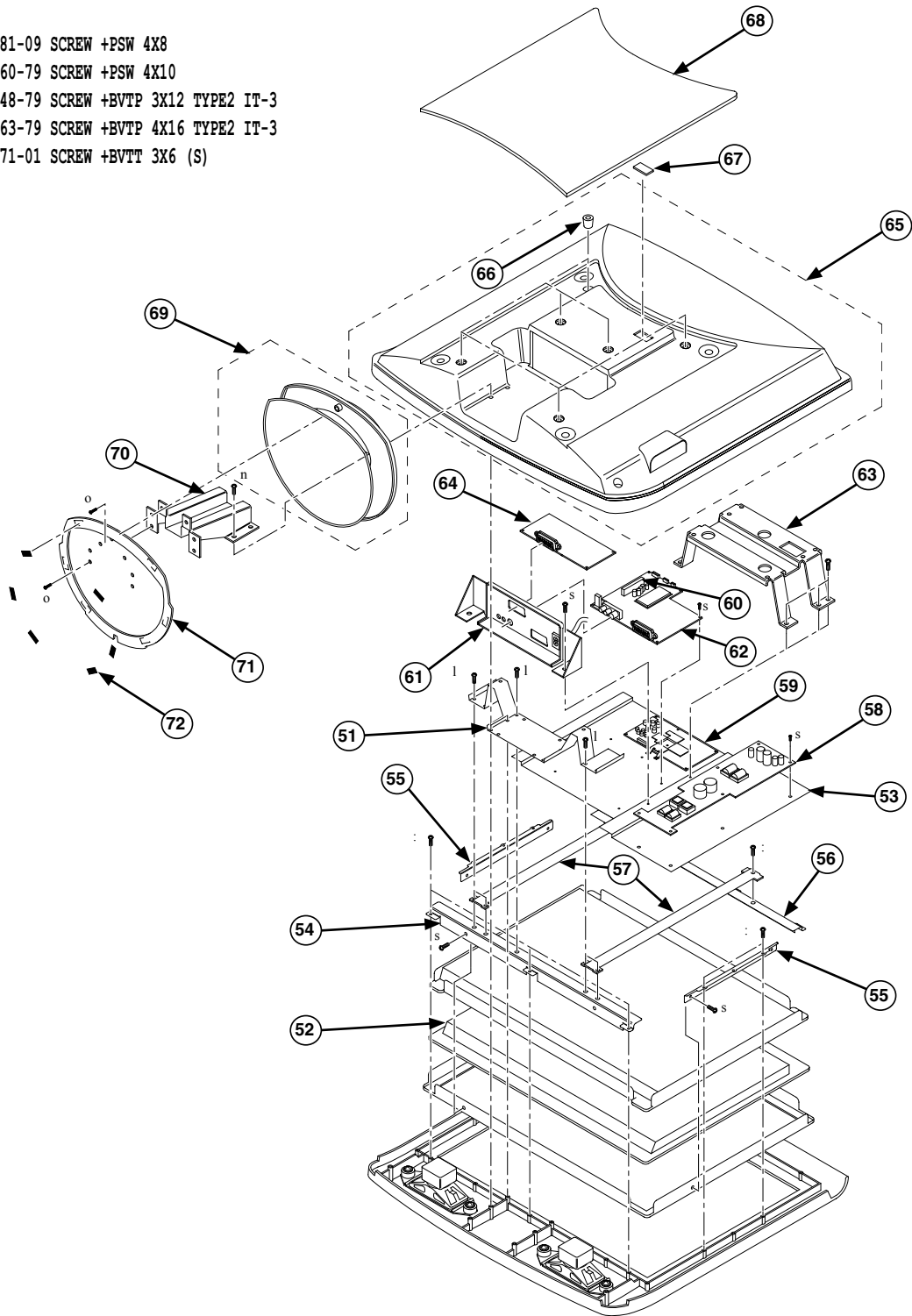

REF.NO.	PART.NO	DESCRIPTION	REMARK	REF.NO.	PART.NO	DESCRIPTION	REMARK
51	*2-178-834-01	LW1 BRACKET		62	*A-1081-021-A	A BOARD, COMPLETE	
52	1-805-758-11	DISPLAY MODULE, LIQUID CRYSTAL		63	*2-178-818-01	VESA BRACKET	
53	*2-178-832-01	MAIN BRACKET		64	*A-1057-432-A	H3 BOARD, COMPLETE	
54	*2-178-830-01	PANEL BRACKET, LOWER		65	X-2024-911-1	REAR CABINET ASSY(27)	66
55	*2-178-815-01	PANEL BRACKET, SIDE		66	4-095-322-01	BUSHING, RUBBER	
56	*2-178-829-01	PANEL BRACKET, UPPER		67	*2-109-144-11	SERVICE, PLATE	
57	*2-178-833-01	VERTICAL FRAME		68	*2-178-828-01	REAR COVER	
58	*A-1096-787-A	G2 BOARD, COMPLETE		69	X-2024-173-1	STAND ASSY	
59	*A-1081-018-A	B BOARD, COMPLETE		70	*2-178-825-01	STAND FOOT	
60	8-597-936-00	TUNER, FSS BTF-EF411Z		71	*2-178-824-01	STAND METAL BASE	
61	*2-178-820-11	TERMINAL BRACKET		72	2-021-805-01	FOOT	

SECTION 6 ELECTRICAL PARTS LIST

PARTS LISTING TABLE OF CONTENTS

	<u>Page</u>
H3 BOARD COMPLETE Parts List :	43
H5 BOARD COMPLETE Parts List :	44
H2 BOARD COMPLETE Parts List :	44
G2 BOARD COMPLETE Parts List :	45
H1 BOARD COMPLETE Parts List :	46
A BOARD COMPLETE Parts List :	47
MISCELLANEOUS :	53
ACCESSORIES AND PACKAGING MATERIALS :	53
REMOTE COMMANDER :	53

Note: The B Board Schematic Diagram, Printed Wiring Board and Parts List are not indicated in this manual as the PWB is regarded as a non service item for exchange only.

Note : Items marked “*” are not stocked since they are seldom required for routine service. Some delay should be anticipated when ordering these items.
Parts indicated (XX) on the Schematic Diagram are not used in this model and therefore do not appear in the Parts List.

REF.NO.	PART.NO	DESCRIPTION	REMARK	REF.NO.	PART.NO	DESCRIPTION	REMARK
* A-1057-432-A H3 Board, Complete							
< CAPACITOR >				< FERRITE BEAD >			
C2702	1-164-227-11	CERAMIC CHIP 0.022UF	10.00% 25V	FB3700	1-216-864-11	SHORT CHIP	0
C2703	1-162-964-11	CERAMIC CHIP 0.001UF	10.00% 50V	< IC >			
C2704	1-164-227-11	CERAMIC CHIP 0.022UF	10.00% 25V	IC3701	6-704-465-01	IC MC74LVX8053DTR2	
C2705	1-162-964-11	CERAMIC CHIP 0.001UF	10.00% 50V	< COIL >			
C2706	1-165-908-11	CERAMIC CHIP 1UF	10% 10V	L2740	1-412-029-11	INDUCTOR	10UH
C2707	1-165-908-11	CERAMIC CHIP 1UF	10% 10V	L3701	1-412-029-11	INDUCTOR	10UH
C2708	1-126-396-11	ELECT CHIP 47UF	20.00% 16V	L3703	1-412-029-11	INDUCTOR	10UH
C2709	1-126-396-11	ELECT CHIP 47UF	20.00% 16V	L3706	1-412-029-11	INDUCTOR	10UH
C2740	1-126-396-11	ELECT CHIP 47UF	20.00% 16V	< TRANSISTOR >			
C2741	1-164-004-11	CERAMIC CHIP 0.1UF	10.00% 25V	Q2700	8-729-010-29	TRANSISTOR MSD601-RST1	
C3701	1-162-962-11	CERAMIC CHIP 470PF	10.00% 50V	Q2701	8-729-010-29	TRANSISTOR MSD601-RST1	
C3714	1-126-394-11	ELECT CHIP 10UF	20.00% 16V	Q3701	8-729-010-29	TRANSISTOR MSD601-RST1	
C3730	1-107-826-11	CERAMIC CHIP 0.1UF	10.00% 16V	Q3702	8-729-010-29	TRANSISTOR MSD601-RST1	
C3731	1-107-826-11	CERAMIC CHIP 0.1UF	10.00% 16V	Q3707	8-729-010-29	TRANSISTOR MSD601-RST1	
C3732	1-126-396-11	ELECT CHIP 47UF	20.00% 16V	Q3708	8-729-010-29	TRANSISTOR MSD601-RST1	
C3738	1-107-826-11	CERAMIC CHIP 0.1UF	10.00% 16V	Q3709	8-729-010-29	TRANSISTOR MSD601-RST1	
C3739	1-126-396-11	ELECT CHIP 47UF	20.00% 16V	Q3711	8-729-010-29	TRANSISTOR MSD601-RST1	
C3742	1-107-826-11	CERAMIC CHIP 0.1UF	10.00% 16V	Q3712	8-729-010-29	TRANSISTOR MSD601-RST1	
C3744	1-126-396-11	ELECT CHIP 47UF	20.00% 16V	< RESISTOR >			
C3745	1-107-826-11	CERAMIC CHIP 0.1UF	10.00% 16V	R2700	1-216-815-11	METAL CHIP	330 5% 1/10W
C3746	1-126-394-11	ELECT CHIP 10UF	20.00% 16V	R2701	1-216-815-11	METAL CHIP	330 5% 1/10W
C3747	1-107-826-11	CERAMIC CHIP 0.1UF	10.00% 16V	R2702	1-216-049-11	RES-CHIP	1K 5% 1/10W
C3748	1-126-396-11	ELECT CHIP 47UF	20.00% 16V	R2703	1-216-049-11	RES-CHIP	1K 5% 1/10W
C3749	1-107-826-11	CERAMIC CHIP 0.1UF	10.00% 16V	R2704	1-216-813-11	METAL CHIP	220 5% 1/10W
C3750	1-126-396-11	ELECT CHIP 47UF	20.00% 16V	R2705	1-216-864-11	SHORT CHIP	0
C3751	1-107-826-11	CERAMIC CHIP 0.1UF	10.00% 16V	R2706	1-216-813-11	METAL CHIP	220 5% 1/10W
< CONNECTOR >				R2707	1-216-864-11	SHORT CHIP	0
CN3700	*1-770-130-11	CONNECTOR (SQUARE TYPE) 21P		R2708	1-216-853-11	METAL CHIP	470K 5% 1/10W
CN3702	1-580-057-11	PIN, CONNECTOR (SMD) 4P		R2709	1-216-853-11	METAL CHIP	470K 5% 1/10W
CN3703	1-774-769-11	CONNECTOR, FFC/FPC 25P		R2710	1-216-853-11	METAL CHIP	470K 5% 1/10W
< DIODE >				R2711	1-216-853-11	METAL CHIP	470K 5% 1/10W
D2700	8-719-069-60	DIODE UDZSTE-179.1B		R2712	1-216-839-11	METAL CHIP	33K 5% 1/10W
D2701	8-719-069-60	DIODE UDZSTE-179.1B		R2713	1-216-836-11	METAL CHIP	18K 5% 1/10W
D2702	8-719-069-60	DIODE UDZSTE-179.1B		R2714	1-216-839-11	METAL CHIP	33K 5% 1/10W
D2703	8-719-069-60	DIODE UDZSTE-179.1B		R2715	1-216-836-11	METAL CHIP	18K 5% 1/10W
D2740	8-719-069-60	DIODE UDZSTE-179.1B		R2718	1-218-841-11	METAL CHIP	560 0.5% 1/10W
D3700	8-719-069-60	DIODE UDZSTE-179.1B		R2719	1-218-841-11	METAL CHIP	560 0.5% 1/10W
D3701	8-719-069-60	DIODE UDZSTE-179.1B		R3701	1-216-029-00	RES-CHIP	150 5% 1/10W
D3702	8-719-069-55	DIODE UDZSTE-175.6B		R3702	1-216-022-00	RES-CHIP	75 5% 1/10W
D3703	8-719-083-63	DIODE UDZSTE-1713B		R3703	1-216-025-11	RES-CHIP	100 5% 1/10W
D3710	8-719-069-60	DIODE UDZSTE-179.1B		R3704	1-216-864-11	SHORT CHIP	0
D3723	8-719-069-60	DIODE UDZSTE-179.1B		R3705	1-216-864-11	SHORT CHIP	0
D3724	8-719-069-60	DIODE UDZSTE-179.1B		R3706	1-216-864-11	SHORT CHIP	0
				R3707	1-216-864-11	SHORT CHIP	0

REF.NO.	PART.NO	DESCRIPTION	REMARK	REF.NO.	PART.NO	DESCRIPTION	REMARK
R3708	1-216-864-11	SHORT CHIP	0			< IC >	
R3709	1-216-025-11	RES-CHIP	100 5% 1/10W				
R3710	1-216-864-11	SHORT CHIP	0	IC9050	8-759-515-60	IC RS-20	
R3711	1-216-864-11	SHORT CHIP	0			< RESISTOR >	
R3713	1-216-864-11	SHORT CHIP	0				
R3714	1-216-864-11	SHORT CHIP	0	R9050	1-216-864-11	SHORT CHIP	0
R3715	1-216-864-11	SHORT CHIP	0	R9051	1-216-805-11	METAL CHIP	47 5% 1/10W
R3716	1-216-864-11	SHORT CHIP	0				
R3717	1-216-029-00	RES-CHIP	150 5% 1/10W				
R3718	1-216-029-00	RES-CHIP	150 5% 1/10W				
R3721	1-216-022-00	RES-CHIP	75 5% 1/10W			< CAPACITOR >	
R3722	1-216-022-00	RES-CHIP	75 5% 1/10W	C9202	1-126-401-21	ELECT CHIP 1UF	20.00% 50V
R3726	1-216-022-00	RES-CHIP	75 5% 1/10W	C9206	1-126-401-21	ELECT CHIP 1UF	20.00% 50V
R3732	1-216-815-11	METAL CHIP	330 5% 1/10W	C9208	1-162-970-11	CERAMIC CHIP 0.01UF	10.00% 25V
R3734	1-216-815-11	METAL CHIP	330 5% 1/10W	C9213	1-162-970-11	CERAMIC CHIP 0.01UF	10.00% 25V
R3743	1-216-833-11	METAL CHIP	10K 5% 1/10W			< CONNECTOR >	
R3744	1-216-833-11	METAL CHIP	10K 5% 1/10W	CN9200	*1-766-376-11	PIN, CONNECTOR (1.5MM) (SMD) 9P	
R3752	1-216-815-11	METAL CHIP	330 5% 1/10W	CN9300	1-573-290-21	PIN, CONNECTOR (1.5MM) (SMD) 4P	
R3753	1-216-821-11	METAL CHIP	1K 5% 1/10W			< DIODE >	
R3773	1-216-839-11	METAL CHIP	33K 5% 1/10W	D9200	8-719-069-60	DIODE UDZSTE-179.1B	
R3774	1-216-833-11	METAL CHIP	10K 5% 1/10W	D9201	8-719-069-60	DIODE UDZSTE-179.1B	
R3776	1-216-815-11	METAL CHIP	330 5% 1/10W	D9300	8-719-978-33	DIODE DTZ-TT11-6.8B	
R3777	1-216-022-00	RES-CHIP	75 5% 1/10W	D9301	8-719-978-33	DIODE DTZ-TT11-6.8B	
R3778	1-216-029-00	RES-CHIP	150 5% 1/10W			< SOCKET >	
R3779	1-216-025-11	RES-CHIP	100 5% 1/10W	J9201	1-750-264-31	JACK	
R3780	1-216-025-11	RES-CHIP	100 5% 1/10W	J9300	1-770-054-11	TERMINAL BLOCK, S(LIGHT ANGLE)	
R3781	1-216-833-11	METAL CHIP	10K 5% 1/10W			< COIL >	
R3782	1-216-833-11	METAL CHIP	10K 5% 1/10W	L9202	1-216-864-11	SHORT CHIP	0
R3784	1-216-815-11	METAL CHIP	330 5% 1/10W	L9203	1-216-864-11	SHORT CHIP	0
R3785	1-216-839-11	METAL CHIP	33K 5% 1/10W	L9204	1-216-864-11	SHORT CHIP	0
R3786	1-216-833-11	METAL CHIP	10K 5% 1/10W	L9205	1-216-864-11	SHORT CHIP	0
R3788	1-216-815-11	METAL CHIP	330 5% 1/10W	L9206	1-216-864-11	SHORT CHIP	0

*** A-1057-434-A H5 Board Complete**

REF.NO.	PART.NO	DESCRIPTION	REMARK
		< CAPACITOR >	
C9050	1-128-589-11	ELECT CHIP 47UF	20.00% 6.3V
C9051	1-119-667-11	CERAMIC CHIP 22UF	10V
C9052	1-162-966-11	CERAMIC CHIP 0.0022UF	10.00% 50V
C9053	1-100-566-91	CERAMIC CHIP 0.1UF	10.00% 25V
		< CONNECTOR >	
CN9050	1-580-789-22	PIN, CONNECTOR (SMD) 6P	
		< DIODE >	
D9050	8-719-069-55	DIODE UDZSTE-175.6B	
D9051	8-719-060-27	DIODE SLR-325MCT31	
D9052	8-719-053-43	DIODE SLR-325VCT31	
D9053	8-719-069-55	DIODE UDZSTE-175.6B	

REF.NO.	PART.NO	DESCRIPTION	REMARK
		< RESISTOR >	
R9200	1-216-853-11	METAL CHIP 470K 5%	1/10W
R9201	1-216-864-11	SHORT CHIP	0
R9202	1-216-821-11	METAL CHIP 1K 5%	1/10W
R9203	1-216-821-11	METAL CHIP 1K 5%	1/10W
R9204	1-216-864-11	SHORT CHIP	0
R9205	1-216-853-11	METAL CHIP 470K 5%	1/10W
R9208	1-216-864-11	SHORT CHIP	0
R9209	1-216-810-11	METAL CHIP 120 5%	1/10W
R9210	1-216-810-11	METAL CHIP 120 5%	1/10W
R9211	1-216-810-11	METAL CHIP 120 5%	1/10W
R9212	1-216-810-11	METAL CHIP 120 5%	1/10W
R9213	1-216-864-11	SHORT CHIP	0

Note : The components identified by shading and marked Δ are critical for safety. Replace only with the part numbers specified in the parts list.

G2

REF.NO.	PART.NO	DESCRIPTION	REMARK	REF.NO.	PART.NO	DESCRIPTION	REMARK
* A-1096-787-A G2 Board Complete				< CONNECTOR >			
	4-382-854-01	SCREW (M3X8) , P, SW (+)		CN6000	1-695-915-11	TAB (CONTACT)	
< CAPACITOR >				CN6001	1-794-032-21	PIN, CONNECTOR (PC BOARD) 11P	
C6000	1-113-924-11	CERAMIC	0.0047UF 20.00% 250V	CN6002	1-794-519-21	PIN, CONNECTOR (PC BOARD) 14P	
C6001	Δ 1-119-899-51	CERAMIC	1000PF 10.00% 250V	CN6003	Δ *1-691-960-11	PIN, CONNECTOR (PC BOARD) 3P	
C6002	Δ 1-161-964-91	CERAMIC	0.0047UF 250V	CN6005	1-573-290-21	PIN, CONNECTOR (1.5MM) (SMD) 4P	
C6003	Δ 1-165-529-11	MYLAR	0.22UF 10 275V	CN6101	*1-816-974-51	PLUG, CONNECTOR 3P	
C6004	Δ 1-165-530-11	MYLAR	0.47UF 10 275V	< DIODE >			
C6005	Δ 1-119-899-51	CERAMIC	1000PF 10.00% 250V	D6000	8-719-510-53	DIODE D4SB60L	
C6006	Δ 1-161-964-91	CERAMIC	0.0047UF 250V	D6001	8-719-082-03	DIODE MM3Z15VT1	
C6007	1-135-361-11	ELECT	180UF 20% 450V	D6002	8-719-081-97	DIODE MMDL914T1	
C6009	1-162-970-11	CERAMIC CHIP	0.01UF 10.00% 25V	D6003	8-719-082-03	DIODE MM3Z15VT1	
C6010	1-162-964-11	CERAMIC CHIP	0.001UF 10.00% 50V	D6004	8-719-082-03	DIODE MM3Z15VT1	
C6011	1-107-905-11	ELECT	4.7UF 20.00% 50V	D6005	8-719-979-64	DIODE UF4005PKG23	
C6012	1-107-888-11	ELECT	47UF 20.00% 25V	D6006	8-719-082-03	DIODE MM3Z15VT1	
C6014	1-136-479-11	FILM	0.001UF 5.00% 100V	D6007	8-719-082-03	DIODE MM3Z15VT1	
C6015	1-162-970-11	CERAMIC CHIP	0.01UF 10.00% 25V	D6015	8-719-083-66	DIODE UDZSTE-1718B	
C6016	1-107-906-11	ELECT	10UF 20.00% 50V	D6016	6-500-501-01	DIODE D10SC6M-4022	
C6018	1-162-970-11	CERAMIC CHIP	0.01UF 10.00% 25V	D6019	6-500-501-01	DIODE D10SC6M-4022	
C6019	1-136-165-00	FILM	0.1UF 5.00% 50V	D6020	8-719-082-75	DIODE FCH08A10	
C6020	1-107-888-11	ELECT	47UF 20.00% 25V	D6021	6-500-253-01	DIODE RB053L-30TE25	
C6021	1-107-824-11	CERAMIC	220PF 5.00% 1KV	D6022	6-500-253-01	DIODE RB053L-30TE25	
C6022	1-107-824-11	CERAMIC	220PF 5.00% 1KV	D6023	8-719-082-75	DIODE FCH08A10	
C6023	1-165-610-11	FILM	33000PF 3% 800V	D6100	8-719-083-60	DIODE UDZSTE-174.7B	
C6024	1-107-902-11	ELECT	1UF 20.00% 50V	D6101	8-719-081-97	DIODE MMDL914T1	
C6027	1-115-339-11	CERAMIC CHIP	0.1UF 10.00% 50V	D6102	6-500-567-31	DIODE 10ERB20-TB3	
C6032	1-162-968-11	CERAMIC CHIP	0.0047UF 10.00% 50V	D6103	8-719-948-45	DIODE ERA22-08	
C6041	1-135-361-11	ELECT	180UF 20% 450V	D6104	8-719-080-75	DIODE M1FL20U-4063	
C6042	1-165-730-31	ELECT	680UF 20% 16V	< FUSE >			
C6045	1-165-737-31	ELECT	1800UF 20% 25V	F6000	Δ 1-576-232-12	FUSE 5A 250V	
C6048	1-165-737-31	ELECT	1800UF 20% 25V	FH6000	Δ 1-533-725-11	FUSE HOLDER	
C6049	1-165-749-31	ELECT	180UF 20% 50V	< IC >			
C6050	1-107-902-11	ELECT	1UF 20.00% 50V	IC6000	6-705-768-01	IC MCZ3001UB	
C6053	1-165-730-31	ELECT	680UF 20% 16V	IC6001	8-759-586-17	IC TL1431CZ-AP	
C6054	1-165-749-31	ELECT	180UF 20% 50V	IC6100	6-600-279-01	IC STR-A6169	
C6100	1-136-201-61	MYLAR	0.22UF 10.00% 400V	IC6101	8-759-586-17	IC TL1431CZ-AP	
C6101	1-109-879-11	CERAMIC	22PF 5.00% 2KV	< COIL >			
C6102	1-107-905-11	ELECT	4.7UF 20.00% 50V	L6000	Δ 1-456-678-11	LINE FILTER COIL	
C6103	1-107-906-11	ELECT	10UF 20.00% 50V	L6008	Δ 1-456-389-11	INDUCTOR 20MH	
C6104	1-162-964-11	CERAMIC CHIP	0.001UF 10.00% 50V	L6009	Δ 1-456-389-11	INDUCTOR 20MH	
C6105	1-107-909-11	ELECT	47UF 20.00% 50V	L6010	1-406-971-21	INDUCTOR 10UH	
C6106	1-104-331-11	CERAMIC	0.0022UF 10.00% 1KV	L6011	1-406-971-21	INDUCTOR 10UH	
C6107	1-107-826-11	CERAMIC CHIP	0.1UF 10.00% 16V	L6100	1-412-537-31	INDUCTOR 100UH	
C6108	1-119-899-51	CERAMIC	1000PF 10.00% 250V				
C6109	1-131-872-91	CERAMIC CHIP	1000PF 10% 630V				
C6110	1-128-945-31	ELECT	1000UF 20% 10V				
C6111	1-107-826-11	CERAMIC CHIP	0.1UF 10.00% 16V				
C6114	1-162-115-00	CERAMIC	330PF 10.00% 1KV				

Note : The components identified by shading and marked Δ are critical for safety. Replace only with the part numbers specified in the parts list.

G2 H1

REF.NO.	PART.NO	DESCRIPTION	REMARK	REF.NO.	PART.NO	DESCRIPTION	REMARK
< PHOTOCOUPLER >				R6034	1-216-833-11	METAL CHIP 10K 5%	1/10W
PH6000	6-600-187-01	PHOTO COUPLER	PC123Y22JOOF	R6035	1-216-822-11	METAL CHIP 1.2K 5%	1/10W
PH6001	6-600-187-01	PHOTO COUPLER	PC123Y22JOOF	R6037	1-216-821-11	METAL CHIP 1K 5%	1/10W
PH6100	6-600-187-01	PHOTO COUPLER	PC123Y22JOOF	R6038	1-216-821-11	METAL CHIP 1K 5%	1/10W
< PROTECTOR MODULE >				R6039	1-216-864-11	SHORT CHIP 0	
PS6001	Δ 1-533-596-21	IC LINK 4A	90V	R6040	1-216-825-11	METAL CHIP 2.2K 5%	1/10W
PS6002	Δ 1-533-596-21	IC LINK 4A	90V	R6041	1-216-864-11	SHORT CHIP 0	
PS6003	Δ 1-533-595-31	IC LINK 3.15A	90V	R6042	1-218-866-11	METAL CHIP 6.2K 0.5%	1/10W
< TRANSISTOR >				R6043	1-218-848-11	METAL CHIP 1.1K 0.5%	1/10W
Q6000	8-729-010-29	TRANSISTOR MSD601-RST1		R6044	1-216-821-11	METAL CHIP 1K 5%	1/10W
Q6001	8-729-010-05	TRANSISTOR MSB709-RT1		R6046	1-216-829-11	METAL CHIP 4.7K 5%	1/10W
Q6002	8-729-010-29	TRANSISTOR MSD601-RST1		R6055	1-245-494-21	METAL 2.2M 2%	1/4W
Q6003	6-550-526-01	TRANSISTOR 2SK2842-LB180		R6056	1-245-494-21	METAL 2.2M 2%	1/4W
Q6004	6-550-526-01	TRANSISTOR 2SK2842-LB180		R6057	1-216-833-11	METAL CHIP 10K 5%	1/10W
Q6005	8-729-010-29	TRANSISTOR MSD601-RST1		R6058	1-245-315-71	METAL OXIDE 0.1 5%	2W
Q6009	8-729-010-25	TRANSISTOR MSD601-RT1		R6062	1-216-864-11	SHORT CHIP 0	
Q6010	8-729-010-05	TRANSISTOR MSB709-RT1		R6100	1-249-389-11	CARBON 4.7 5%	1/4W
< RESISTOR >				R6101	1-216-353-00	METAL OXIDE 2.2 5%	1W
R6003	Δ 1-219-759-11	METAL 1M 5%	1/2W	R6105	1-216-864-11	SHORT CHIP 0	
R6004	1-216-837-11	METAL CHIP 22K 5%	1/10W	R6106	1-249-393-11	CARBON 10 5%	1/4W
R6005	1-216-833-11	METAL CHIP 10K 5%	1/10W	R6107	1-243-725-71	METAL OXIDE 100K 5%	1W
R6006	Δ 1-202-933-61	FUSIBLE 0.1 10%	1/2W	R6108	1-216-864-11	SHORT CHIP 0	
R6007	1-218-879-11	METAL CHIP 22K 0.5%	1/10W	R6109	1-216-817-11	METAL CHIP 470 5%	1/10W
R6009	1-218-823-11	METAL CHIP 100 0.5%	1/10W	R6110	1-216-821-11	METAL CHIP 1K 5%	1/10W
R6011	1-218-875-11	METAL CHIP 15K 0.5%	1/10W	R6111	1-216-864-11	SHORT CHIP 0	
R6012	1-208-847-11	METAL CHIP 510K 0.5%	1/10W	R6112	1-216-839-11	METAL CHIP 33K 5%	1/10W
R6013	1-208-847-11	METAL CHIP 510K 0.5%	1/10W	R6113	1-218-871-11	METAL CHIP 10K 0.5%	1/10W
R6014	1-208-847-11	METAL CHIP 510K 0.5%	1/10W	R6114	1-218-871-11	METAL CHIP 10K 0.5%	1/10W
R6015	1-208-847-11	METAL CHIP 510K 0.5%	1/10W	< TRANSFORMER >			
R6017	1-216-845-11	METAL CHIP 100K 5%	1/10W	T6001	Δ 1-443-384-11	CONVERTER TRANSFORMER (PIT)	
R6018	1-216-833-11	METAL CHIP 10K 5%	1/10W	T6002	Δ 1-443-564-11	POWER ISOLATION TRANSFORMER (PIT)	
R6019	1-216-833-11	METAL CHIP 10K 5%	1/10W	T6100	Δ 1-443-312-11	TRANSFORMER, CONVERTER (SBT)	
R6020	1-216-837-11	METAL CHIP 22K 5%	1/10W	< VARISTOR >			
R6021	1-218-823-11	METAL CHIP 100 0.5%	1/10W	VR6000	Δ 1-804-995-11	VARISTOR	
R6022	1-216-837-11	METAL CHIP 22K 5%	1/10W	* A-1072-345-A H1 Board Complete			
R6023	1-249-393-11	CARBON 10 5%	1/4W	< CAPACITOR >			
R6024	1-249-393-11	CARBON 10 5%	1/4W	C9000	1-164-156-11	CERAMIC CHIP 0.1UF	25V
R6025	1-216-833-11	METAL CHIP 10K 5%	1/10W	C9001	1-164-156-11	CERAMIC CHIP 0.1UF	25V
R6026	1-216-833-11	METAL CHIP 10K 5%	1/10W	< CONNECTOR >			
R6027	1-216-821-11	METAL CHIP 1K 5%	1/10W	CN9000	1-580-057-11	PIN, CONNECTOR (SMD) 4P	
R6028	1-216-864-11	SHORT CHIP 0		< DIODE >			
R6029	1-216-817-11	METAL CHIP 470 5%	1/10W	D9000	8-719-069-55	DIODE UDZSTE-175.6B	
R6030	1-245-315-71	METAL OXIDE 0.1 5%	2W	D9001	8-719-069-55	DIODE UDZSTE-175.6B	
R6031	1-216-864-11	SHORT CHIP 0					
R6032	1-216-837-11	METAL CHIP 22K 5%	1/10W				
R6033	1-216-837-11	METAL CHIP 22K 5%	1/10W				

REF.NO.	PART.NO	DESCRIPTION	REMARK	REF.NO.	PART.NO	DESCRIPTION	REMARK
< RESISTOR >				C1302	1-162-970-11	CERAMIC CHIP 0.01UF	10.00% 25V
R9000	1-216-829-11	METAL CHIP 4.7K 5%	1/10W	C2000	1-125-889-91	CERAMIC CHIP 2.2UF	10% 10V
R9001	1-216-833-11	METAL CHIP 10K 5%	1/10W	C2001	1-125-889-91	CERAMIC CHIP 2.2UF	10% 10V
R9002	1-216-837-11	METAL CHIP 22K 5%	1/10W	C2002	1-126-396-11	ELECT CHIP 47UF	20.00% 16V
R9004	1-216-864-11	SHORT CHIP 0		C2003	1-164-004-11	CERAMIC CHIP 0.1UF	10.00% 25V
R9005	1-216-829-11	METAL CHIP 4.7K 5%	1/10W	C2005	1-162-966-11	CERAMIC CHIP 0.0022UF	10.00% 50V
R9006	1-216-833-11	METAL CHIP 10K 5%	1/10W	C2006	1-164-004-11	CERAMIC CHIP 0.1UF	10.00% 25V
R9007	1-216-864-11	SHORT CHIP 0		C2007	1-107-823-11	CERAMIC CHIP 0.47UF	10.00% 16V
R9008	1-216-864-11	SHORT CHIP 0		C2009	1-162-966-11	CERAMIC CHIP 0.0022UF	10.00% 50V
< SWITCH >				C2010	1-162-966-11	CERAMIC CHIP 0.0022UF	10.00% 50V
S9000	1-786-420-11	TACTILE SWITCH		C2011	1-107-823-11	CERAMIC CHIP 0.47UF	10.00% 16V
S9001	1-786-420-11	TACTILE SWITCH		C2012	1-115-416-11	CERAMIC CHIP 0.001UF	5.00% 25V
S9002	1-786-420-11	TACTILE SWITCH		C2013	1-162-966-11	CERAMIC CHIP 0.0022UF	10.00% 50V
S9003	1-786-420-11	TACTILE SWITCH		C2014	1-162-966-11	CERAMIC CHIP 0.0022UF	10.00% 50V
S9004	1-786-420-11	TACTILE SWITCH		C2015	1-162-906-11	CERAMIC CHIP 1.5PF	0.25PF 50V
S9005	1-786-420-11	TACTILE SWITCH		C2016	1-162-966-11	CERAMIC CHIP 0.0022UF	10.00% 50V
S9006	1-786-420-11	TACTILE SWITCH		C2017	1-162-906-11	CERAMIC CHIP 1.5PF	0.25PF 50V
* A-1081-021-A A Board Complete				C2018	1-162-966-11	CERAMIC CHIP 0.0022UF	10.00% 50V
	4-382-854-01	SCREW (M3X8), P, SW (+)		C2019	1-162-927-11	CERAMIC CHIP 100PF	5.00% 50V
< CAPACITOR >				C2020	1-162-927-11	CERAMIC CHIP 100PF	5.00% 50V
C0001	1-126-396-11	ELECT CHIP 47UF	20.00% 16V	C2021	1-162-966-11	CERAMIC CHIP 0.0022UF	10.00% 50V
C0002	1-107-826-11	CERAMIC CHIP 0.1UF	10.00% 16V	C2023	1-126-394-11	ELECT CHIP 10UF	20.00% 16V
C0003	1-126-394-11	ELECT CHIP 10UF	20.00% 16V	C2024	1-126-394-11	ELECT CHIP 10UF	20.00% 16V
C0011	1-126-394-11	ELECT CHIP 10UF	20.00% 16V	C2025	1-126-396-11	ELECT CHIP 47UF	20.00% 16V
C0030	1-126-396-11	ELECT CHIP 47UF	20.00% 16V	C2026	1-164-004-11	CERAMIC CHIP 0.1UF	10.00% 25V
C0031	1-107-826-11	CERAMIC CHIP 0.1UF	10.00% 16V	C2027	1-126-394-11	ELECT CHIP 10UF	20.00% 16V
C0032	1-107-826-11	CERAMIC CHIP 0.1UF	10.00% 16V	C2028	1-126-396-11	ELECT CHIP 47UF	20.00% 16V
C1101	1-162-921-11	CERAMIC CHIP 33PF	5.00% 50V	C2029	1-164-004-11	CERAMIC CHIP 0.1UF	10.00% 25V
C1104	1-162-925-11	CERAMIC CHIP 68PF	5.00% 50V	C2030	1-126-394-11	ELECT CHIP 10UF	20.00% 16V
C1105	1-162-925-11	CERAMIC CHIP 68PF	5.00% 50V	C2032	1-164-004-11	CERAMIC CHIP 0.1UF	10.00% 25V
C1106	1-126-964-11	ELECT 10UF	20.00% 50V	C2033	1-164-004-11	CERAMIC CHIP 0.1UF	10.00% 25V
C1107	1-162-921-11	CERAMIC CHIP 33PF	5.00% 50V	C2036	1-162-966-11	CERAMIC CHIP 0.0022UF	10.00% 50V
C1108	1-162-968-11	CERAMIC CHIP 0.0047UF	10.00% 50V	C2037	1-162-966-11	CERAMIC CHIP 0.0022UF	10.00% 50V
C1109	1-162-921-11	CERAMIC CHIP 33PF	5.00% 50V	C2100	1-162-968-11	CERAMIC CHIP 0.0047UF	10.00% 50V
C1110	1-126-396-11	ELECT CHIP 47UF	20.00% 16V	C2102	1-216-864-11	SHORT CHIP 0	
C1111	1-162-921-11	CERAMIC CHIP 33PF	5.00% 50V	C2103	1-162-928-11	CERAMIC CHIP 120PF	5.00% 50V
C1200	1-127-573-11	CERAMIC CHIP 1UF	10% 16V	C2105	1-125-891-11	CERAMIC CHIP 0.47UF	10.00% 10V
C1201	1-162-966-11	CERAMIC CHIP 0.0022UF	10.00% 50V	C2200	1-104-665-11	ELECT 100UF	20.00% 25V
C1202	1-162-964-11	CERAMIC CHIP 0.001UF	10.00% 50V	C2201	1-115-339-11	CERAMIC CHIP 0.1UF	10.00% 50V
C1203	1-162-927-11	CERAMIC CHIP 100PF	5.00% 50V	C2202	1-125-889-91	CERAMIC CHIP 2.2UF	10% 10V
C1204	1-127-573-11	CERAMIC CHIP 1UF	10% 16V	C2203	1-127-760-11	CERAMIC CHIP 4.7UF	10.00% 6.3V
C1205	1-127-715-91	CERAMIC CHIP 0.22UF	10% 16V	C2250	1-127-861-11	CERAMIC CHIP 2.2UF	10% 16V
C1207	1-126-396-11	ELECT CHIP 47UF	20.00% 16V	C2300	1-126-935-11	ELECT 470UF	20.00% 16V
C1300	1-126-394-11	ELECT CHIP 10UF	20.00% 16V	C2301	1-126-396-11	ELECT CHIP 47UF	20.00% 16V
C1301	1-126-396-11	ELECT CHIP 47UF	20.00% 16V	C2304	1-126-396-11	ELECT CHIP 47UF	20.00% 16V
				C2309	1-126-396-11	ELECT CHIP 47UF	20.00% 16V
				C2310	1-126-396-11	ELECT CHIP 47UF	20.00% 16V
				C2311	1-107-826-11	CERAMIC CHIP 0.1UF	10.00% 16V
				C2312	1-107-826-11	CERAMIC CHIP 0.1UF	10.00% 16V
				C2313	1-127-573-11	CERAMIC CHIP 1UF	10% 16V

REF.NO.	PART.NO	DESCRIPTION	REMARK	REF.NO.	PART.NO	DESCRIPTION	REMARK
C2400	1-162-970-11	CERAMIC CHIP 0.01UF	10.00% 25V	C3816	1-165-176-11	CERAMIC CHIP 0.047UF	10.00% 16V
C2401	1-162-970-11	CERAMIC CHIP 0.01UF	10.00% 25V	C3820	1-107-826-11	CERAMIC CHIP 0.1UF	10.00% 16V
C2404	1-126-401-21	ELECT CHIP 1UF	20.00% 50V	C3821	1-162-914-11	CERAMIC CHIP 9PF	0.50PF 50V
C2405	1-126-401-21	ELECT CHIP 1UF	20.00% 50V	C3822	1-126-394-11	ELECT CHIP 10UF	20.00% 16V
C2406	1-126-396-11	ELECT CHIP 47UF	20.00% 16V	C3823	1-126-396-11	ELECT CHIP 47UF	20.00% 16V
C2407	1-107-826-11	CERAMIC CHIP 0.1UF	10.00% 16V	C3824	1-162-970-11	CERAMIC CHIP 0.01UF	10.00% 25V
C2410	1-107-826-11	CERAMIC CHIP 0.1UF	10.00% 16V	C3825	1-162-970-11	CERAMIC CHIP 0.01UF	10.00% 25V
C2411	1-107-826-11	CERAMIC CHIP 0.1UF	10.00% 16V	C3826	1-107-826-11	CERAMIC CHIP 0.1UF	10.00% 16V
C2413	1-127-573-11	CERAMIC CHIP 1UF	10% 16V	C3827	1-126-396-11	ELECT CHIP 47UF	20.00% 16V
C2414	1-127-573-11	CERAMIC CHIP 1UF	10% 16V	C3828	1-162-970-11	CERAMIC CHIP 0.01UF	10.00% 25V
C2500	1-127-573-11	CERAMIC CHIP 1UF	10% 16V	C3829	1-107-826-11	CERAMIC CHIP 0.1UF	10.00% 16V
C2501	1-127-573-11	CERAMIC CHIP 1UF	10% 16V	C3830	1-126-396-11	ELECT CHIP 47UF	20.00% 16V
C2502	1-126-396-11	ELECT CHIP 47UF	20.00% 16V	C3831	1-107-826-11	CERAMIC CHIP 0.1UF	10.00% 16V
C2507	1-126-396-11	ELECT CHIP 47UF	20.00% 16V	C3832	1-107-826-11	CERAMIC CHIP 0.1UF	10.00% 16V
C2508	1-128-526-11	ELECT 100UF	20.00% 25V	C3833	1-127-760-11	CERAMIC CHIP 4.7UF	10% 6.3V
C2510	1-165-629-91	CERAMIC CHIP 1UF	10% 50V	C3835	1-107-826-11	CERAMIC CHIP 0.1UF	10.00% 16V
C2511	1-135-374-11	ELECT 1000UF	20% 35V	C3836	1-107-826-11	CERAMIC CHIP 0.1UF	10.00% 16V
C2512	1-115-339-11	CERAMIC CHIP 0.1UF	10.00% 50V	C3837	1-126-396-11	ELECT CHIP 47UF	20.00% 16V
C2513	1-135-374-11	ELECT 1000UF	20% 35V	C3838	1-126-396-11	ELECT CHIP 47UF	20.00% 16V
C2514	1-115-339-11	CERAMIC CHIP 0.1UF	10.00% 50V	C3841	1-127-715-91	CERAMIC CHIP 0.22UF	10% 16V
C2515	1-126-971-11	ELECT 470UF	20.00% 50V	C6200	1-162-974-11	CERAMIC CHIP 0.01UF	50V
C2516	1-126-971-11	ELECT 470UF	20.00% 50V	C6201	1-162-974-11	CERAMIC CHIP 0.01UF	50V
C2600	1-127-573-11	CERAMIC CHIP 1UF	10% 16V	C6204	1-162-970-11	CERAMIC CHIP 0.01UF	10.00% 25V
C2601	1-127-573-11	CERAMIC CHIP 1UF	10% 16V	C6205	1-162-974-11	CERAMIC CHIP 0.01UF	50V
C2602	1-126-396-11	ELECT CHIP 47UF	20.00% 16V	C6207	1-162-974-11	CERAMIC CHIP 0.01UF	50V
C2603	1-164-156-11	CERAMIC CHIP 0.1UF	25V	C6209	1-162-974-11	CERAMIC CHIP 0.01UF	50V
C2608	1-165-908-11	CERAMIC CHIP 1UF	10% 10V	C6210	1-162-974-11	CERAMIC CHIP 0.01UF	50V
C2609	1-165-908-11	CERAMIC CHIP 1UF	10% 10V	C6211	1-162-974-11	CERAMIC CHIP 0.01UF	50V
C2620	1-164-227-11	CERAMIC CHIP 0.022UF	10.00% 25V	C6216	1-162-974-11	CERAMIC CHIP 0.01UF	50V
C2621	1-162-964-11	CERAMIC CHIP 0.001UF	10.00% 50V	C6218	1-162-974-11	CERAMIC CHIP 0.01UF	50V
C2622	1-164-227-11	CERAMIC CHIP 0.022UF	10.00% 25V	C6226	1-115-339-11	CERAMIC CHIP 0.1UF	10.00% 50V
C2623	1-162-964-11	CERAMIC CHIP 0.001UF	10.00% 50V	C6227	1-104-665-11	ELECT 100UF	20.00% 25V
C2624	1-165-908-11	CERAMIC CHIP 1UF	10% 10V	C6228	1-162-970-11	CERAMIC CHIP 0.01UF	10.00% 25V
C2625	1-165-908-11	CERAMIC CHIP 1UF	10% 10V	C6230	1-128-527-11	ELECT 330UF	20.00% 25V
C2626	1-126-947-11	ELECT 47UF	20.00% 35V	C6237	1-100-566-91	CERAMIC CHIP 0.1UF	10.00% 25V
C2627	1-126-947-11	ELECT 47UF	20.00% 35V	C6238	1-115-339-11	CERAMIC CHIP 0.1UF	10.00% 50V
C3603	1-126-947-11	ELECT 47UF	20.00% 35V	C6239	1-104-665-11	ELECT 100UF	20.00% 25V
C3608	1-162-970-11	CERAMIC CHIP 0.01UF	10.00% 25V	C6242	1-128-528-11	ELECT 470UF	20.00% 25V
C3801	1-162-970-11	CERAMIC CHIP 0.01UF	10.00% 25V	C6246	1-100-566-91	CERAMIC CHIP 0.1UF	10.00% 25V
C3802	1-126-396-11	ELECT CHIP 47UF	20.00% 16V	C6267	1-126-947-11	ELECT 47UF	20.00% 35V
C3803	1-162-970-11	CERAMIC CHIP 0.01UF	10.00% 25V	C6269	1-100-566-91	CERAMIC CHIP 0.1UF	10.00% 25V
C3804	1-126-396-11	ELECT CHIP 47UF	20.00% 16V	C6270	1-162-995-11	CERAMIC CHIP 0.022UF	50V
C3806	1-126-396-11	ELECT CHIP 47UF	20.00% 16V	C6271	1-126-963-11	ELECT 4.7UF	20.00% 50V
C3807	1-107-826-11	CERAMIC CHIP 0.1UF	10.00% 16V	C6272	1-126-967-11	ELECT 47UF	20.00% 50V
C3808	1-107-826-11	CERAMIC CHIP 0.1UF	10.00% 16V	< CONNECTOR >			
C3809	1-107-826-11	CERAMIC CHIP 0.1UF	10.00% 16V	CN0041	1-573-806-21	PIN, CONNECTOR (1.5MM) (SMD) 6P	
C3810	1-125-889-91	CERAMIC CHIP 2.2UF	10% 10V	CN0042	*1-564-508-11	PLUG, CONNECTOR 5P	
C3811	1-164-227-11	CERAMIC CHIP 0.022UF	10.00% 25V	CN0043	1-793-358-21	PIN (PWB) (30P), CONNECTOR	
C3812	1-162-970-11	CERAMIC CHIP 0.01UF	10.00% 25V	CN2211	*1-766-376-11	PIN, CONNECTOR (1.5MM) (SMD) 9P	
C3814	1-162-970-11	CERAMIC CHIP 0.01UF	10.00% 25V				

REF.NO.	PART.NO	DESCRIPTION	REMARK	REF.NO.	PART.NO	DESCRIPTION	REMARK
CN2500	*1-564-507-11	PLUG, CONNECTOR 4P				< FILTER >	
CN3602	*1-770-130-11	CONNECTOR (SQUARE TYPE) 21P					
CN3621	1-774-769-11	CONNECTOR, FFC/FPC 25P		FL3800	1-233-765-21	FILTER	
CN6201	1-573-290-21	PIN, CONNECTOR (1.5MM) (SMD) 4P				< IC >	
CN6202	1-573-806-21	PIN, CONNECTOR (1.5MM) (SMD) 6P					
CN6204	1-794-032-21	PIN, CONNECTOR (PC BOARD) 11P		IC0001	8-759-561-69	IC PCF8574TS-T	
		< DIODE >		IC0002	8-759-701-01	IC NJM2904M	
D1200	8-719-081-97	DIODE MMDL914T1		IC0030	8-759-561-69	IC PCF8574TS-T	
D2001	8-719-069-60	DIODE UDZSTE-179.1B		IC1200	8-759-514-57	IC BA7046F	
D2200	8-719-081-97	DIODE MMDL914T1		IC2000	6-706-636-01	IC MSP3410G-QA-C12-0001	
D2201	8-719-081-97	DIODE MMDL914T1		IC2300	8-759-576-76	IC TDA2822D013TR	
D2202	8-719-081-97	DIODE MMDL914T1		IC2400	8-759-278-58	IC NJM4558V-TE2	
D2203	8-719-081-97	DIODE MMDL914T1		IC2500	8-759-246-70	IC TA8216H	
D2204	8-719-081-97	DIODE MMDL914T1		IC3801	8-753-212-10	IC CXA2163AQ-T6	
D2205	8-719-081-97	DIODE MMDL914T1		IC3811	8-759-481-08	IC TC7SET02FU(TE85R)	
D2400	8-719-069-60	DIODE UDZSTE-179.1B		IC6202	6-705-025-01	IC PQ20WZ1UJ00H	
D2401	8-719-069-60	DIODE UDZSTE-179.1B		IC6205	6-704-407-01	IC PQ1CZ41H2ZPH	
D2402	8-719-081-97	DIODE MMDL914T1		IC6208	8-749-925-00	IC TK11819MTL	
D2500	6-500-253-01	DIODE RB053L-30TE25				< SOCKET >	
D2600	8-719-069-60	DIODE UDZSTE-179.1B		J2400	1-794-623-21	JACK, PIN 2P	
D2604	8-719-069-60	DIODE UDZSTE-179.1B				< COIL >	
D2605	8-719-069-60	DIODE UDZSTE-179.1B		L1100	1-414-580-21	INDUCTOR	100NH
D2606	8-719-069-60	DIODE UDZSTE-179.1B		L1101	1-414-760-21	FERRITE	0UH
D2607	8-719-069-60	DIODE UDZSTE-179.1B		L1102	1-414-580-21	INDUCTOR	100NH
D3601	8-719-069-55	DIODE UDZSTE-175.6B		L1103	1-414-760-21	FERRITE	0UH
D3626	8-719-069-60	DIODE UDZSTE-179.1B		L1104	1-414-580-21	INDUCTOR	100NH
D3627	8-719-083-63	DIODE UDZSTE-1713B		L1105	1-412-029-11	INDUCTOR	10UH
D3628	8-719-069-55	DIODE UDZSTE-175.6B		L1106	1-412-979-21	INDUCTOR	1UH
D3629	8-719-069-55	DIODE UDZSTE-175.6B		L1107	1-412-029-11	INDUCTOR	10UH
D3630	8-719-069-60	DIODE UDZSTE-179.1B		L1200	1-412-029-11	INDUCTOR	10UH
D3631	8-719-069-55	DIODE UDZSTE-175.6B		L1300	1-412-029-11	INDUCTOR	10UH
D3634	8-719-069-60	DIODE UDZSTE-179.1B		L2000	1-412-029-11	INDUCTOR	10UH
D6202	8-719-081-97	DIODE MMDL914T1		L2001	1-412-029-11	INDUCTOR	10UH
D6204	8-719-081-97	DIODE MMDL914T1		L2002	1-412-029-11	INDUCTOR	10UH
D6205	8-719-081-34	DIODE RB160M-30TR		L2100	1-216-864-11	SHORT CHIP	0
D6209	6-500-295-01	DIODE PTZ-TE25-5.6B		L2101	1-412-990-41	INDUCTOR	8.2UH
D6217	8-719-081-97	DIODE MMDL914T1		L2300	1-412-029-11	INDUCTOR	10UH
		< FERRITE BEAD >		L2400	1-412-029-11	INDUCTOR	10UH
FB1101	1-216-864-11	SHORT CHIP	0	L2500	1-406-661-21	INDUCTOR	22UH
FB2200	1-469-324-21	FERRITE	0UH	L2600	1-412-029-11	INDUCTOR	10UH
FB2500	1-469-324-21	FERRITE	0UH	L3600	1-412-029-11	INDUCTOR	10UH
FB2501	1-469-324-21	FERRITE	0UH	L3801	1-412-029-11	INDUCTOR	10UH
FB3609	1-216-864-11	SHORT CHIP	0	L3802	1-216-864-11	SHORT CHIP	0
FB3610	1-216-864-11	SHORT CHIP	0	L3803	1-216-864-11	SHORT CHIP	0
FB6200	1-216-295-91	SHORT CHIP	0	L3804	1-216-864-11	SHORT CHIP	0
FB6203	1-216-295-91	SHORT CHIP	0	L3805	1-412-029-11	INDUCTOR	10UH
FB6204	1-216-295-91	SHORT CHIP	0	L3806	1-412-029-11	INDUCTOR	10UH
FB6208	1-414-864-11	FERRITE	0UH				

Note : The components identified by shading and marked Δ are critical for safety. Replace only with the part numbers specified in the parts list.

A

REF.NO.	PART.NO	DESCRIPTION	REMARK	REF.NO.	PART.NO	DESCRIPTION	REMARK
L3807	1-412-029-11	INDUCTOR	10UH	Q3808	8-729-010-29	TRANSISTOR MSD601-RST1	
L3808	1-412-029-11	INDUCTOR	10UH	Q3809	8-729-010-05	TRANSISTOR MSB709-RT1	
L3809	1-412-029-11	INDUCTOR	10UH	Q6200	8-729-045-62	TRANSISTOR 2SK2158-T2B	
L3810	1-412-029-11	INDUCTOR	10UH	Q6203	8-729-010-29	TRANSISTOR MSD601-RST1	
L3811	1-412-029-11	INDUCTOR	10UH				
L6202	1-424-918-21	INDUCTOR	10UH				
L6205	1-456-504-21	INDUCTOR	100UH				
L6215	1-410-120-11	INDUCTOR	1.2MH				
	< PROTECTOR MODULE >						
PS2500	Δ 1-576-390-91	IC LINK	2.5A 50V				
	< TRANSISTOR >						
Q0001	8-729-010-29	TRANSISTOR MSD601-RST1		JR2200	1-216-864-11	SHORT CHIP	0
Q0002	8-729-028-28	TRANSISTOR 2SK2036 (TE85L)		JR2300	1-216-864-11	SHORT CHIP	0
Q0046	8-729-010-29	TRANSISTOR MSD601-RST1		JR3905	1-216-864-11	SHORT CHIP	0
Q0047	8-729-010-29	TRANSISTOR MSD601-RST1		JR3906	1-216-864-11	SHORT CHIP	0
Q1100	8-729-010-29	TRANSISTOR MSD601-RST1		JR3907	1-216-864-11	SHORT CHIP	0
Q1200	8-729-010-29	TRANSISTOR MSD601-RST1		JR3908	1-216-864-11	SHORT CHIP	0
Q1201	8-729-010-05	TRANSISTOR MSB709-RT1		JR6201	1-216-295-91	SHORT CHIP	0
Q1300	8-729-010-29	TRANSISTOR MSD601-RST1		JR6211	1-216-295-91	SHORT CHIP	0
Q1301	8-729-010-05	TRANSISTOR MSB709-RT1		JR6212	1-216-295-91	SHORT CHIP	0
Q2000	8-729-010-29	TRANSISTOR MSD601-RST1		JR6213	1-216-295-91	SHORT CHIP	0
Q2001	8-729-010-29	TRANSISTOR MSD601-RST1		JR6214	1-216-295-91	SHORT CHIP	0
Q2002	8-729-010-29	TRANSISTOR MSD601-RST1		JR6215	1-216-295-91	SHORT CHIP	0
Q2100	8-729-010-29	TRANSISTOR MSD601-RST1		JR6216	1-216-295-91	SHORT CHIP	0
Q2101	8-729-010-05	TRANSISTOR MSB709-RT1		JR6217	1-216-295-91	SHORT CHIP	0
Q2200	1-801-806-11	TRANSISTOR DTC144EKA		JR6218	1-216-295-91	SHORT CHIP	0
Q2201	8-729-027-38	TRANSISTOR DTA144EKA-T146		R0001	1-216-864-11	SHORT CHIP	0
Q2202	8-729-010-29	TRANSISTOR MSD601-RST1		R0002	1-216-809-11	METAL CHIP	100 5% 1/10W
Q2203	1-801-806-11	TRANSISTOR DTC144EKA		R0003	1-216-809-11	METAL CHIP	100 5% 1/10W
Q2204	8-729-010-29	TRANSISTOR MSD601-RST1		R0004	1-216-821-11	METAL CHIP	1K 5% 1/10W
Q2205	8-729-010-29	TRANSISTOR MSD601-RST1		R0005	1-216-809-11	METAL CHIP	100 5% 1/10W
Q2206	8-729-010-29	TRANSISTOR MSD601-RST1		R0006	1-216-864-11	SHORT CHIP	0
Q2207	8-729-010-29	TRANSISTOR MSD601-RST1		R0007	1-216-864-11	SHORT CHIP	0
Q2300	8-729-010-29	TRANSISTOR MSD601-RST1		R0008	1-216-809-11	METAL CHIP	100 5% 1/10W
Q2301	8-729-010-29	TRANSISTOR MSD601-RST1		R0009	1-216-809-11	METAL CHIP	100 5% 1/10W
Q2400	8-729-015-39	TRANSISTOR DTC323TK		R0010	1-216-833-11	METAL CHIP	10K 5% 1/10W
Q2401	8-729-015-39	TRANSISTOR DTC323TK		R0011	1-216-833-11	METAL CHIP	10K 5% 1/10W
Q2404	8-729-026-49	TRANSISTOR 2SA1037AK-T146-R		R0012	1-216-809-11	METAL CHIP	100 5% 1/10W
Q2405	8-729-015-39	TRANSISTOR DTC323TK		R0013	1-216-833-11	METAL CHIP	10K 5% 1/10W
Q2406	8-729-015-39	TRANSISTOR DTC323TK		R0014	1-216-864-11	SHORT CHIP	0
Q2600	8-729-010-29	TRANSISTOR MSD601-RST1		R0015	1-216-833-11	METAL CHIP	10K 5% 1/10W
Q2601	8-729-010-29	TRANSISTOR MSD601-RST1		R0017	1-216-828-11	METAL CHIP	3.9K 5% 1/10W
Q3600	8-729-010-29	TRANSISTOR MSD601-RST1		R0024	1-216-833-11	METAL CHIP	10K 5% 1/10W
Q3801	8-729-010-05	TRANSISTOR MSB709-RT1		R0025	1-216-833-11	METAL CHIP	10K 5% 1/10W
Q3802	8-729-010-05	TRANSISTOR MSB709-RT1		R0026	1-216-833-11	METAL CHIP	10K 5% 1/10W
Q3806	8-729-010-05	TRANSISTOR MSB709-RT1		R0027	1-216-809-11	METAL CHIP	100 5% 1/10W
Q3807	8-729-010-05	TRANSISTOR MSB709-RT1		R0028	1-216-864-11	SHORT CHIP	0
				R0030	1-216-864-11	SHORT CHIP	0
				R0031	1-216-809-11	METAL CHIP	100 5% 1/10W
				R0032	1-216-809-11	METAL CHIP	100 5% 1/10W
				R0033	1-216-809-11	METAL CHIP	100 5% 1/10W
				R0034	1-216-864-11	SHORT CHIP	0
				R0035	1-216-864-11	SHORT CHIP	0
				R0036	1-216-864-11	SHORT CHIP	0
				R0037	1-216-809-11	METAL CHIP	100 5% 1/10W

REF.NO.	PART.NO	DESCRIPTION	REMARK			REF.NO.	PART.NO	DESCRIPTION	REMARK		
R0038	1-216-809-11	METAL CHIP	100	5%	1/10W	R2011	1-218-841-11	METAL CHIP	560	0.5%	1/10W
R0039	1-216-809-11	METAL CHIP	100	5%	1/10W	R2012	1-216-845-11	METAL CHIP	100K	5%	1/10W
R0040	1-216-864-11	SHORT CHIP	0			R2013	1-216-864-11	SHORT CHIP	0		
R0041	1-216-833-11	METAL CHIP	10K	5%	1/10W	R2014	1-216-864-11	SHORT CHIP	0		
R0042	1-216-809-11	METAL CHIP	100	5%	1/10W	R2015	1-216-833-11	METAL CHIP	10K	5%	1/10W
R0043	1-216-813-11	METAL CHIP	220	5%	1/10W	R2016	1-216-829-11	METAL CHIP	4.7K	5%	1/10W
R0047	1-216-830-11	METAL CHIP	5.6K	5%	1/10W	R2017	1-216-829-11	METAL CHIP	4.7K	5%	1/10W
R0048	1-216-833-11	METAL CHIP	10K	5%	1/10W	R2018	1-216-829-11	METAL CHIP	4.7K	5%	1/10W
R0049	1-216-833-11	METAL CHIP	10K	5%	1/10W	R2019	1-216-829-11	METAL CHIP	4.7K	5%	1/10W
R0050	1-216-833-11	METAL CHIP	10K	5%	1/10W	R2021	1-216-829-11	METAL CHIP	4.7K	5%	1/10W
R0051	1-216-833-11	METAL CHIP	10K	5%	1/10W	R2022	1-216-829-11	METAL CHIP	4.7K	5%	1/10W
R0052	1-216-809-11	METAL CHIP	100	5%	1/10W	R2031	1-216-845-11	METAL CHIP	100K	5%	1/10W
R0053	1-216-833-11	METAL CHIP	10K	5%	1/10W	R2102	1-216-805-11	METAL CHIP	47	5%	1/10W
R0054	1-216-811-11	METAL CHIP	150	5%	1/10W	R2103	1-216-821-11	METAL CHIP	1K	5%	1/10W
R0055	1-216-864-11	SHORT CHIP	0			R2106	1-216-821-11	METAL CHIP	1K	5%	1/10W
R0056	1-216-809-11	METAL CHIP	100	5%	1/10W	R2159	1-216-829-11	METAL CHIP	4.7K	5%	1/10W
R0057	1-216-833-11	METAL CHIP	10K	5%	1/10W	R2200	1-216-833-11	METAL CHIP	10K	5%	1/10W
R1100	1-216-836-11	METAL CHIP	18K	5%	1/10W	R2201	1-216-837-11	METAL CHIP	22K	5%	1/10W
R1101	1-216-833-11	METAL CHIP	10K	5%	1/10W	R2202	1-216-853-11	METAL CHIP	470K	5%	1/10W
R1102	1-216-864-11	SHORT CHIP	0			R2204	1-216-818-11	METAL CHIP	560	5%	1/10W
R1104	1-216-809-11	METAL CHIP	100	5%	1/10W	R2205	1-216-864-11	SHORT CHIP	0		
R1105	1-216-809-11	METAL CHIP	100	5%	1/10W	R2206	1-216-833-11	METAL CHIP	10K	5%	1/10W
R1107	1-216-864-11	SHORT CHIP	0			R2208	1-216-829-11	METAL CHIP	4.7K	5%	1/10W
R1108	1-216-864-11	SHORT CHIP	0			R2209	1-216-809-11	METAL CHIP	100	5%	1/10W
R1109	1-216-864-11	SHORT CHIP	0			R2210	1-216-809-11	METAL CHIP	100	5%	1/10W
R1200	1-216-833-11	METAL CHIP	10K	5%	1/10W	R2211	1-216-847-11	METAL CHIP	150K	5%	1/10W
R1201	1-216-812-11	METAL CHIP	180	5%	1/10W	R2212	1-216-828-11	METAL CHIP	3.9K	5%	1/10W
R1202	1-216-821-11	METAL CHIP	1K	5%	1/10W	R2213	1-216-837-11	METAL CHIP	22K	5%	1/10W
R1203	1-218-898-11	METAL CHIP	130K	0.5%	1/10W	R2214	1-216-833-11	METAL CHIP	10K	5%	1/10W
R1204	1-216-853-11	METAL CHIP	470K	5%	1/10W	R2215	1-218-325-11	RES-CHIP	120	5%	1/4W
R1205	1-216-850-11	METAL CHIP	270K	5%	1/10W	R2216	1-218-325-11	RES-CHIP	120	5%	1/4W
R1206	1-216-853-11	METAL CHIP	470K	5%	1/10W	R2217	1-218-818-11	RES-CHIP	220	5%	1/2W
R1207	1-216-853-11	METAL CHIP	470K	5%	1/10W	R2219	1-216-864-11	SHORT CHIP	0		
R1208	1-216-829-11	METAL CHIP	4.7K	5%	1/10W	R2255	1-216-821-11	METAL CHIP	1K	5%	1/10W
R1209	1-216-864-11	SHORT CHIP	0			R2256	1-216-827-11	METAL CHIP	3.3K	5%	1/10W
R1301	1-216-829-11	METAL CHIP	4.7K	5%	1/10W	R2303	1-216-825-11	METAL CHIP	2.2K	5%	1/10W
R1302	1-216-830-11	METAL CHIP	5.6K	5%	1/10W	R2305	1-216-825-11	METAL CHIP	2.2K	5%	1/10W
R1303	1-216-821-11	METAL CHIP	1K	5%	1/10W	R2306	1-216-805-11	METAL CHIP	47	5%	1/10W
R1304	1-216-821-11	METAL CHIP	1K	5%	1/10W	R2307	1-216-805-11	METAL CHIP	47	5%	1/10W
R1305	1-216-822-11	METAL CHIP	1.2K	5%	1/10W	R2308	1-216-833-11	METAL CHIP	10K	5%	1/10W
R1306	1-216-797-11	METAL CHIP	10	5%	1/10W	R2309	1-216-833-11	METAL CHIP	10K	5%	1/10W
R1307	1-216-864-11	SHORT CHIP	0			R2310	1-216-829-11	METAL CHIP	4.7K	5%	1/10W
R2000	1-414-760-21	FERRITE	0UH			R2311	1-216-829-11	METAL CHIP	4.7K	5%	1/10W
R2001	1-414-760-21	FERRITE	0UH			R2314	1-216-809-11	METAL CHIP	100	5%	1/10W
R2003	1-216-839-11	METAL CHIP	33K	5%	1/10W	R2315	1-216-813-11	METAL CHIP	220	5%	1/10W
R2004	1-216-836-11	METAL CHIP	18K	5%	1/10W	R2316	1-216-809-11	METAL CHIP	100	5%	1/10W
R2005	1-218-841-11	METAL CHIP	560	0.5%	1/10W	R2317	1-216-813-11	METAL CHIP	220	5%	1/10W
R2007	1-216-809-11	METAL CHIP	100	5%	1/10W	R2318	1-216-809-11	METAL CHIP	100	5%	1/10W
R2008	1-216-839-11	METAL CHIP	33K	5%	1/10W	R2319	1-216-809-11	METAL CHIP	100	5%	1/10W
R2009	1-216-836-11	METAL CHIP	18K	5%	1/10W	R2400	1-216-815-11	METAL CHIP	330	5%	1/10W

REF.NO.	PART.NO	DESCRIPTION	REMARK			REF.NO.	PART.NO	DESCRIPTION	REMARK		
R2401	1-216-815-11	METAL CHIP	330	5%	1/10W	R2631	1-216-864-11	SHORT CHIP	0		
R2404	1-216-864-11	SHORT CHIP	0			R2632	1-216-853-11	METAL CHIP	470K	5%	1/10W
R2411	1-216-864-11	SHORT CHIP	0			R2633	1-216-853-11	METAL CHIP	470K	5%	1/10W
R2412	1-216-853-11	METAL CHIP	470K	5%	1/10W	R2634	1-216-853-11	METAL CHIP	470K	5%	1/10W
R2413	1-216-864-11	SHORT CHIP	0			R2635	1-216-853-11	METAL CHIP	470K	5%	1/10W
R2414	1-216-864-11	SHORT CHIP	0			R2636	1-216-864-11	SHORT CHIP	0		
R2415	1-216-841-11	METAL CHIP	47K	5%	1/10W	R2652	1-216-864-11	SHORT CHIP	0		
R2416	1-216-841-11	METAL CHIP	47K	5%	1/10W	R2662	1-216-836-11	METAL CHIP	18K	5%	1/10W
R2417	1-216-841-11	METAL CHIP	47K	5%	1/10W	R2663	1-216-839-11	METAL CHIP	33K	5%	1/10W
R2420	1-216-837-11	METAL CHIP	22K	5%	1/10W	R3600	1-216-821-11	METAL CHIP	1K	5%	1/10W
R2421	1-216-841-11	METAL CHIP	47K	5%	1/10W	R3601	1-216-809-11	METAL CHIP	100	5%	1/10W
R2423	1-216-821-11	METAL CHIP	1K	5%	1/10W	R3603	1-216-025-11	RES-CHIP	100	5%	1/10W
R2424	1-218-873-11	METAL CHIP	12K	0.5%	1/10W	R3613	1-216-022-00	RES-CHIP	75	5%	1/10W
R2425	1-218-873-11	METAL CHIP	12K	0.5%	1/10W	R3614	1-216-025-11	RES-CHIP	100	5%	1/10W
R2426	1-216-833-11	METAL CHIP	10K	5%	1/10W	R3615	1-216-022-00	RES-CHIP	75	5%	1/10W
R2427	1-216-833-11	METAL CHIP	10K	5%	1/10W	R3616	1-216-022-00	RES-CHIP	75	5%	1/10W
R2428	1-216-817-11	METAL CHIP	470	5%	1/10W	R3617	1-216-022-00	RES-CHIP	75	5%	1/10W
R2429	1-216-817-11	METAL CHIP	470	5%	1/10W	R3618	1-216-029-00	RES-CHIP	150	5%	1/10W
R2430	1-216-864-11	SHORT CHIP	0			R3619	1-216-025-11	RES-CHIP	100	5%	1/10W
R2431	1-216-864-11	SHORT CHIP	0			R3621	1-216-025-11	RES-CHIP	100	5%	1/10W
R2500	1-216-829-11	METAL CHIP	4.7K	5%	1/10W	R3622	1-216-025-11	RES-CHIP	100	5%	1/10W
R2501	1-216-829-11	METAL CHIP	4.7K	5%	1/10W	R3623	1-216-025-11	RES-CHIP	100	5%	1/10W
R2502	1-216-864-11	SHORT CHIP	0			R3624	1-216-022-00	RES-CHIP	75	5%	1/10W
R2503	1-216-826-11	METAL CHIP	2.7K	5%	1/10W	R3625	1-216-025-11	RES-CHIP	100	5%	1/10W
R2505	1-216-864-11	SHORT CHIP	0			R3626	1-216-029-00	RES-CHIP	150	5%	1/10W
R2506	1-216-826-11	METAL CHIP	2.7K	5%	1/10W	R3803	1-216-830-11	METAL CHIP	5.6K	5%	1/10W
R2508	1-216-296-11	SHORT CHIP	0			R3804	1-216-818-11	METAL CHIP	560	5%	1/10W
R2510	1-216-864-11	SHORT CHIP	0			R3805	1-216-817-11	METAL CHIP	470	5%	1/10W
R2511	1-216-296-11	SHORT CHIP	0			R3811	1-216-809-11	METAL CHIP	100	5%	1/10W
R2512	1-220-230-11	RES-CHIP	2.2	10%	1/4W	R3812	1-216-809-11	METAL CHIP	100	5%	1/10W
R2513	1-220-230-11	RES-CHIP	2.2	10%	1/4W	R3813	1-216-864-11	SHORT CHIP	0		
R2517	1-216-864-11	SHORT CHIP	0			R3814	1-216-820-11	METAL CHIP	820	5%	1/10W
R2518	1-216-864-11	SHORT CHIP	0			R3818	1-216-864-11	SHORT CHIP	0		
R2519	1-216-864-11	SHORT CHIP	0			R3822	1-216-821-11	METAL CHIP	1K	5%	1/10W
R2520	1-216-864-11	SHORT CHIP	0			R3833	1-216-821-11	METAL CHIP	1K	5%	1/10W
R2521	1-216-864-11	SHORT CHIP	0			R3835	1-216-828-11	METAL CHIP	3.9K	5%	1/10W
R2522	1-216-864-11	SHORT CHIP	0			R3836	1-216-838-11	METAL CHIP	27K	5%	1/10W
R2523	1-216-864-11	SHORT CHIP	0			R3841	1-218-847-11	METAL CHIP	1K	0.5%	1/10W
R2614	1-216-864-11	SHORT CHIP	0			R3842	1-218-845-11	METAL CHIP	820	0.5%	1/10W
R2615	1-216-864-11	SHORT CHIP	0			R3843	1-218-867-11	METAL CHIP	6.8K	0.5%	1/10W
R2619	1-218-841-11	METAL CHIP	560	0.5%	1/10W	R3844	1-216-821-11	METAL CHIP	1K	5%	1/10W
R2620	1-216-836-11	METAL CHIP	18K	5%	1/10W	R3845	1-218-867-11	METAL CHIP	6.8K	0.5%	1/10W
R2622	1-216-839-11	METAL CHIP	33K	5%	1/10W	R3847	1-216-809-11	METAL CHIP	100	5%	1/10W
R2623	1-218-841-11	METAL CHIP	560	0.5%	1/10W	R3852	1-216-809-11	METAL CHIP	100	5%	1/10W
R2624	1-216-815-11	METAL CHIP	330	5%	1/10W	R3855	1-216-864-11	SHORT CHIP	0		
R2625	1-216-049-11	RES-CHIP	1K	5%	1/10W	R3856	1-216-809-11	METAL CHIP	100	5%	1/10W
R2626	1-216-815-11	METAL CHIP	330	5%	1/10W	R3863	1-216-809-11	METAL CHIP	100	5%	1/10W
R2627	1-216-049-11	RES-CHIP	1K	5%	1/10W	R3864	1-216-809-11	METAL CHIP	100	5%	1/10W
R2628	1-216-813-11	METAL CHIP	220	5%	1/10W	R3866	1-216-809-11	METAL CHIP	100	5%	1/10W
R2630	1-216-813-11	METAL CHIP	220	5%	1/10W	R3867	1-216-825-11	METAL CHIP	2.2K	5%	1/10W

Note : The components identified by shading and marked Δ are critical for safety. Replace only with the part numbers specified in the parts list.

A

REF.NO.	PART.NO	DESCRIPTION	REMARK
R3868	1-216-811-11	METAL CHIP	150 5% 1/10W
R3869	1-216-825-11	METAL CHIP	2.2K 5% 1/10W
R3870	1-211-985-11	METAL CHIP	47 0.5% 1/10W
R3872	1-216-864-11	SHORT CHIP	0
R3873	1-216-864-11	SHORT CHIP	0
R3874	1-216-864-11	SHORT CHIP	0
R3875	1-216-864-11	SHORT CHIP	0
R3876	1-216-864-11	SHORT CHIP	0
R6202	1-216-833-11	METAL CHIP	10K 5% 1/10W
R6204	1-216-295-91	SHORT CHIP	0
R6205	1-216-849-11	METAL CHIP	220K 5% 1/10W
R6206	1-216-833-11	METAL CHIP	10K 5% 1/10W
R6210	1-216-827-11	METAL CHIP	3.3K 5% 1/10W
R6211	1-218-867-11	METAL CHIP	6.8K 0.5% 1/10W
R6224	1-218-850-11	METAL CHIP	1.3K 0.5% 1/10W
R6225	1-218-861-11	METAL CHIP	3.9K 0.5% 1/10W
R6257	1-216-808-11	METAL CHIP	82 5% 1/10W
R6258	1-216-295-91	SHORT CHIP	0
	< TUNER >		
TU1100	8-597-936-00	TUNER, FSS BTF-EF411Z	
	< VARISTOR >		
VD2500	1-801-925-21	VARISTOR, CHIP	(1608)
VD2501	1-801-925-21	VARISTOR, CHIP	(1608)
VD2502	1-216-864-11	SHORT CHIP	0
	< CRYSTAL >		
X2000	1-795-612-11	VIBRATOR, CRYSTAL	
X3800	1-781-914-21	VIBRATOR, CRYSTAL	

REF.NO.	PART.NO	DESCRIPTION	REMARK
MISCELLANEOUS			
	1-826-042-11	LOUDSPEAKER (5X15CM)	
	1-805-758-11	DISPLAY MODULE, LIQUID CRYSTAL	
	8-597-936-00	TUNER, FSS BTF-EF411Z	
ACCESSORIES AND PACKAGING MATERIALS			
Δ	1-827-479-11	POWER SUPPLY CORD	
Δ	1-827-482-11	POWER SUPPLY CORD	
	4-099-720-02	HOOK	
	*2-148-373-02	BAG, PROTECTION	
	*2-348-297-01	INDIVIDUAL CARTON	
	*2-348-298-01	CUSHION UPPER (L)	
	*2-348-299-01	CUSHION UPPER (R)	
	*2-348-300-01	CUSHION LOWER CENTER	
	*2-338-301-01	BOX, ACCESSORY	
	*2-348-576-01	CUSHION LOWER	
	*2-349-939-01	LOWER CENTER CUSHION BOARD	
	*4-102-248-01	SHEET, PROTECTION CROSS	
	2-349-779-11	INSTRUCTION MANUAL (ENGLISH/RUSSIAN/POLISH/PORTUGUESE)	
	2-349-779-21	INSTRUCTION MANUAL (GERMAN/FRENCH/DUTCH/ITALIAN)	
	2-349-779-31	INSTRUCTION MANUAL (DANISH/FINNISH/SWEDISH SPANISH)	
	2-349-779-41	INSTRUCTION MANUAL (ENGLISH)	
REMOTE COMMANDER			
	1-478-815-12	REMOTE COMMANDER (RM-Y1108)	

TRACE

A new TV Repair Assistance Tool that combines ease of use and powerful PC software tools to allow you to save valuable time during many TV repairs.



The TRACE interface connects to the PC's serial port. It provides connection to the TV's I²C bus and can be provided with an InfraRed transmitter (optional).

The interface is powered by a standard 9 V PP3 battery for portable use, and can also be powered by an external 9V/25mA DC power supply.

The TRACE software that is supplied with the interface allows you to:

- Read, restore and compare NVM contents via the I²C bus
- Acknowledge check of all I²C devices in the TV set
- Read Error Codes (emulation of the Error Reader tool)

With the optional IR Add-on kit, the following features can be added:

- Remote Commander emulation
- User programmable Functional Check through Infrared
- Fast and documented Test Mode setting of all Sony TV chassis

Additional features such as Adjustments and Troubleshooting are available in chassis-dependent software modules. Please contact your local Sony Service organisation for the latest information.

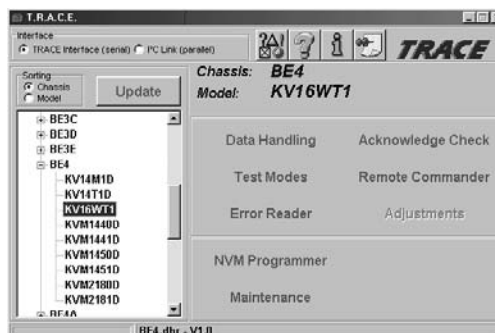

Note: For workshops already using the existing I²C Link parallel port interface (9-948-320-30), this software can be used as well, replacing the TV Data Handling software (9-948-340-50), but Error Reader and IR functions can only be accessed with the TRACE interface.

Partnumbers: TRACE Starter Kit (TRACE interface + software): 9-948-320-70
TRACE Software (for users of the I²C Link interface): 9-948-340-80
TRACE IR Add-on (IR interface + Remote Commander software): 9-948-320-80

PC requirements: IBM-compatible PC with operating system Windows95, Windows98, or WindowsNT*.

* WindowsNT only supported with TRACE interface

If you need more information on Computer and Electronic Repair, please visit these websites to improve yourself.

<http://www.fastrepairguide.com>

<http://www.protech2u.com>

<http://www.plasma-television-repair.com>

<http://www.lcd-television-repair.com>

Happy Repairing!!

Highly Recommended Repair Ebook:

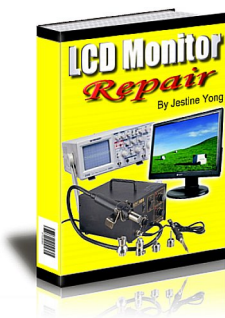

If you're a LCD Monitor repairer, then this is the best guide for you. Why? Because, the author revealed all his LCD Monitor Repairing secrets for you. I think, with just few Repair tips you learned from this guide you will get back your investment!

[Click Here to read](#) more.



This eBook will show you how to test the electronic component correctly and accurately. Some of you may say that I don't need this eBook because it is too simple! Do you know that, in fact there is lots of testing electronic components secrets I have learned from this guide? Do you know how to test a 'TRIAC' correctly and accurately? If you answer no then I guess you have to get this eBook. [Click Here to read more.](#)

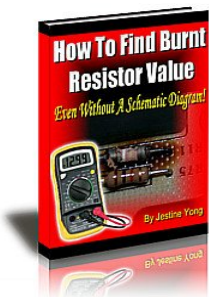

Are you tired of searching the service manuals to look for the value of a burnt resistor? If the answer is YES, then this eBook is a 'must have' guide for you. You can save a lot of time and be able to repair customer's Electronic equipment with burnt resistors in it.

[Click here to read more.](#)