

# BARNES®

## INSTALLATION and OPERATION MANUAL Solids Handling Submersible Pump

18 Frame

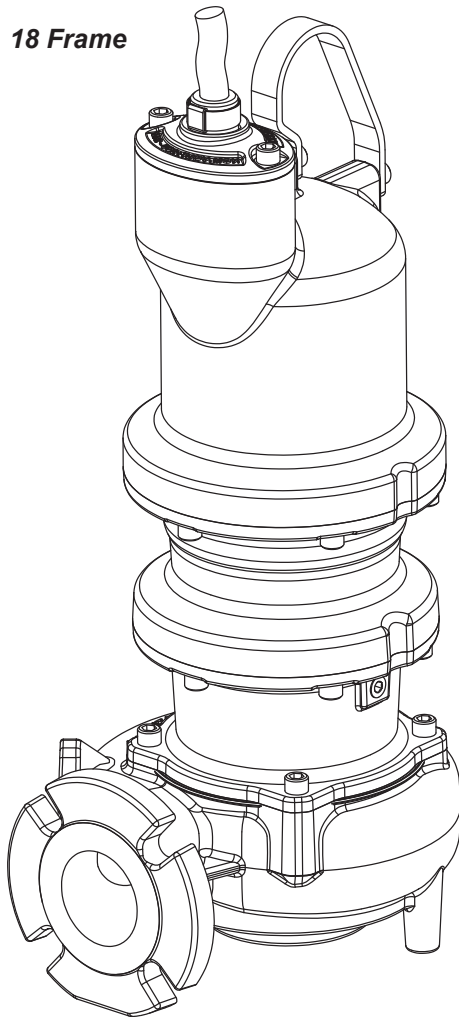

**3SHV**  
**Vortex Pumps**  
**5 - 10HP, 3450RPM**  
**2 - 7.5HP, 1750RPM**

**3SHM**  
**Monovane Pumps**  
**3 - 7.5HP, 1750RPM**

**4SHV**  
**Vortex Pumps**  
**2 - 10HP, 1750RPM**

**4SHM**  
**Monovane Pumps**  
**3 - 10HP, 1750RPM**

**4SHD**  
**Dual Vane Pumps**  
**3 - 10HP, 1750RPM**

This product may be covered by one or more of the following patents and other patent(s) pending: US Patent 7,931,473 & 8,128,360

**IMPORTANT!**

*Read all instructions in this manual before operating pump.  
As a result of Crane Pumps & Systems, Inc., constant product improvement program,  
product changes may occur. As such Crane Pumps & Systems reserves the right to  
change product without prior written notification.*

**CRANE**

A Crane Co. Company

### PUMPS & SYSTEMS

420 Third Street  
Piqua, Ohio 45356  
Phone: (937) 778-8947  
Fax: (937) 773-7157  
www.cranepumps.com

83 West Drive, Bramton  
Ontario, Canada L6T 2J6  
Phone: (905) 457-6223  
Fax: (905) 457-2650



Form No. 133030-Rev. AF

# TABLE OF CONTENTS

	SAFETY FIRST .....	3
A.	GENERAL INFORMATION.....	4
B.	INSTALLATION.....	4 - 17
	ELECTRICAL DATA.....	6 - 18
C.	START-UP OPERATION .....	18 - 19
D.	PREVENTATIVE MAINTENANCE.....	19
E.	SERVICE and REPAIR.....	19 - 20
F.	REPLACEMENT PARTS .....	21
	TROUBLE SHOOTING.....	22
	RECOMMENDED MINIMUM SUCTION CLEARANCE (Fig. 9).....	23
	SH - CROSS-SECTIONS, (Fig. 10 & 11) & EXPLODED VIEWS, (Fig. 12).....	24 - 25
	PARTS LISTS AND KITS .....	26 - 35
	WARRANTY .....	37
	RETURNED GOODS POLICY .....	38
	WARRANTY REGISTRATION.....	38
	START-UP REPORT .....	39 - 40

Other brand and product names are trademarks or registered trademarks of their respective holders.

© Barnes is a registered trademark of Crane Pumps & Systems, Inc  
1995,1997,1998,1/2004, 4/05, 1/06, 3/06, 9/06, 12/06, 2/07

Alteration Rights Reserved

# SAFETY FIRST!

Please Read This Before Installing Or Operating Pump.  
This information is provided for **SAFETY and to PREVENT EQUIPMENT PROBLEMS**. To help recognize this information, observe the following symbols:



**IMPORTANT!** Warns about hazards that can result in personal injury or Indicates factors concerned with assembly, installation, operation, or maintenance which could result in damage to the machine or equipment if ignored.

**CAUTION !** Warns about hazards that can or will cause minor personal injury or property damage if ignored. Used with symbols below.

**WARNING !** Warns about hazards that can or will cause serious personal injury, death, or major property damage if ignored. Used with symbols below.



*Hazardous fluids can cause fire or explosions, burns or death could result.*



*Extremely hot - Severe burnes can occur on contact.*



*Biohazard can cause serious personal injury.*



*Hazardous fluids can Hazardous pressure, eruptions or explosions could cause personal injury or property damage.*



*Rotating machinery Amputation or severe laceration can result.*



*Hazardous voltage can shock, burn or cause death.*

Only qualified personnel should install, operate and repair pump. Any wiring of pumps should be performed by a qualified electrician.



**WARNING !** - To reduce risk of electrical shock, pumps and control panels must be properly grounded in accordance with the National Electric Code (NEC) or the Canadian Electrical Code (CEC) and all applicable state, province, local codes and ordinances.

**WARNING!** - To reduce risk of electrical shock, always disconnect the pump from the power source before handling or servicing. Lock out power and tag.



**WARNING!** Operation against a closed discharge valve will cause premature bearing and seal failure on any pump, and on end suction and

self priming pump the heat build may cause the generation of steam with resulting dangerous pressures. It is recommended that a high case temperature switch or pressure relief valve be installed on the pump body.



**CAUTION !** Never operate a pump with a plug-in type power cord without a ground fault circuit interrupter.



**CAUTION!** Pumps build up heat and pressure during operation-allow time for pumps to cool before handling or servicing.



**WARNING!** - **DO NOT** pump hazardous materials (flammable, caustic, etc.) unless the pump is specifically designed and designated to handle them.



Do not block or restrict discharge hose, as discharge hose may whip under pressure.



**WARNING! - DO NOT** wear loose clothing that may become entangled in the impeller or other moving parts.



**WARNING!** - Keep clear of suction and discharge openings. **DO NOT** insert fingers in pump with power connected.



Always wear eye protection when working on pumps.



Make sure lifting handles are securely fastened each time before lifting. **DO NOT** operate pump without safety devices in place. Always replace safety devices that have been removed during service or repair. Secure the pump in its operating position so it can not tip over, fall or slide.



**DO NOT** exceed manufacturers recommendation for maximum performance, as this could cause the motor to overheat.

**DO NOT** remove cord and strain relief. Do not connect conduit to pump.



**WARNING!** Cable should be protected at all times to avoid punctures, cut, bruises and abrasions - inspect frequently. Never handle connected power cords with wet hands.



**WARNING!** To reduce risk of electrical shock, all wiring and junction connections should be made per the NEC or CEC and applicable state or province and local codes. Requirements may vary depending on usage and location.

**WARNING!** Submersible Pumps are not approved for use in swimming pools, recreational water installations, decorative fountains or any installation where human contact with the pumped fluid is common.



**WARNING!** Products Returned Must Be Cleaned, Sanitized, Or Decontaminated As Necessary Prior To Shipment, To Insure That Employees Will Not Be Exposed To Health Hazards In Handling Said Material. All Applicable Laws And Regulations Shall Apply.



Bronze/brass and bronze/brass fitted pumps may contain lead levels higher than considered safe for potable water systems. Lead is known to cause cancer and birth defects or other reproductive harm. Various government agencies have determined that leaded copper alloys should not be used in potable water applications. For non-leaded copper alloy materials of construction, please contact factory.



**IMPORTANT!** - Crane Pumps & Systems, Inc. is not responsible for losses, injury, or death resulting from a failure to observe these safety precautions, misuse or abuse of pumps or equipment.

## SECTION A: GENERAL INFORMATION

### A-1) To the Purchaser:

Congratulations! You are the owner of one of the finest pumps on the market today. CP&S pumps are products engineered and manufactured of high quality components. Over one hundred years of pump building experience along with a continuing quality assurance program combine to produce a pump which will stand up to the toughest applications. This manual will provide helpful information concerning installation, maintenance, and proper service guidelines.

### A-2) Receiving:

Upon receiving the pump, it should be inspected for damage or shortages. If damage has occurred, file a claim immediately with the company that delivered the pump. **MAKE CERTAIN TO RETAIN THIS MANUAL!**

### A-3) Storage:

**Short Term-** CP&S Pumps are manufactured for efficient performance following short inoperative periods in storage. For best results, pumps can be retained in storage, as factory assembled, in a dry atmosphere with constant temperatures for up to six (6) months.

**Long Term** - Any length of time exceeding six (6) months, but not more than twenty-four (24) months. The unit should be stored in a temperature controlled area, a roofed over walled enclosure that provides protection from the elements (rain, snow, wind-blown dust, etc.), and whose temperature can be maintained between +40 deg. F and +120 deg. F. (4.4 - 49°C). Pump should be stored in its original shipping container. On initial start up, rotate impeller by hand to assure seal and impeller rotate freely. If it is required that the pump be installed and tested before the long term storage begins, such installation will be allowed provided:

- 1.) The pump is not installed under water for more than one (1) month.
- 2.) Immediately upon satisfactory completion of the test, the pump is removed, thoroughly dried, repacked in the original shipping container, and placed in a temperature controlled storage area.

### A-4) Service Centers:

For the location of the nearest Barnes Service Center, check your Barnes representative or Crane Pumps & Systems, Inc., Service Department in Piqua, Ohio, telephone (937) 778-8947 or Crane Pumps & Systems Canada, in Brampton, Ontario, (905) 457-6223.

## SECTION B: INSTALLATION

### B-1) Location:

These self-contained pumping units are recommended for use in a sump, lift station or basin. This pump is designed for submerged continuous duty (15 minutes duty in air at nameplate horsepower), pumping sewage, effluent, wastewater or other nonexplosive or noncorrosive liquids not above 104°F (40°C). Never install the pump in a trench, ditch or hole with a dirt bottom; the legs will sink into the dirt and the suction will become plugged.

### B-1.1) Submergence:

It is recommended that the pump be operated in the Continuous Duty Submergence condition and the sump liquid level should never be less than the Minimum Submergence Level (See Fig. 1). The time required to draw the well down from top of motor to the minimum submergence level should not be greater than 15 minutes.

**NOTE:** Outer shaft seal must be in liquid when motor is operated, whether motor is submerged or in air.

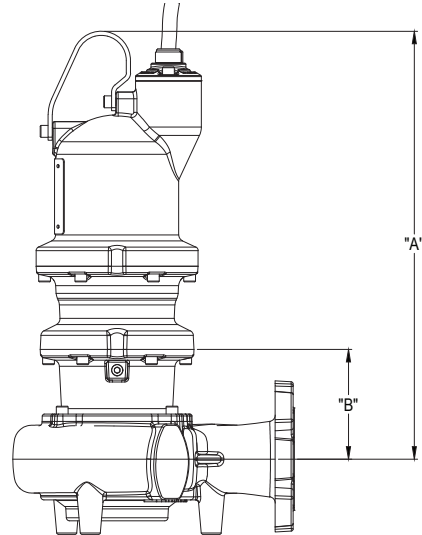

RECOMMENDED SUBMERGENCE LEVELS		
DISCHARGE	"A" CONTINUOUS DUTY SUBMERGENCE	"B" MINIMUM SUBMERGENCE
3"	26.30	7.25
4"	26.20	7.16

### B-2) Discharge:

Discharge piping should be as short as possible. Both a check valve and a shut-off valve are recommended for each pump being used. The check valve is used to prevent backflow into the sump. Excessive backflow can cause flooding and/or damage to the pump. The shut-off valve is used to stop system flow during pump or check valve servicing.

Barnes Pumps manufactures a break away fitting discharge system designed to allow the submersible wastewater pump to be installed or removed without requiring personnel to enter the wet well. Place the Break Away Fitting (BAF) in position. Temporarily secure the guide rails in the upper mounting brackets and locate the base elbow on the bottom of the wet well. Level the base elbow with grout and/or shims. Install the intermediate support brackets, if required. Make sure the rails are in a true vertical position so the pump will clear the access opening and will slide freely down the rails into place on the discharge base elbow. Once the rails are in proper alignment, bolt the base elbow into the floor of the station and connect the discharge pipe to the elbow. Connect the movable portion and other supplied fittings of the BAF onto the pump and lower into wet well. See the Break Away Fitting manual for more information.

### B-3) Liquid Level Controls:

It is recommended to use a liquid level control system that allows the on and off point to be separated by at least twelve inches. An additional set point (lag point) should be incorporated with an alternator switching system for a duplex (two pump) station. A high level alarm may be required to alert maintenance personnel that there is a high water situation in the wet well should the output of the pump station drop below the inflow rate. A low level cut off may be installed to provide system shutdown if the main level control system malfunctions. The off point should be positioned so that the liquid level never drops below the minimum continuous duty point for the pump shown in figure 1.

### B-4.1) Electrical Connections:

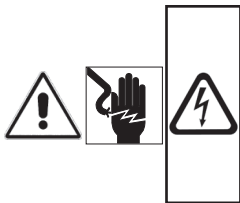

**WARNING!** - All model pumps and control panels must be properly grounded per the NATIONAL ELECTRIC CODE or CANADIAN ELECTRIC CODE, State, Province and local codes. Improper grounding voids warranty.

### B-4) Power/Control Cord:

The power/control cord used with pump has a patented "quick disconnect" feature that allows the cord to be easily attached and disconnected at the pump. The maximum amperage rating for the cord is cast in the top of the cast stainless mounting plate. The voltage connection for the motor is determined by the cord assembly used. Low voltage cords (208 & 230 Volt) utilize a molded quick connect plug that is colored black. High voltage cords (460 & 575 Volt) utilize a molded quick connect cord that is colored orange. **It is important to verify that the cord being used is rated for the nameplate voltage and amperage rating shown on the pump nameplate. Refer to Chart on page 7.** No internal wiring adjustments are necessary for dual and tri-voltage pumps. All jumper connections to set the proper voltage are made by the cord plug itself.

A flat alignment mark is molded into the plug and mating socket on the pump. These should be used as a visual indication as to the correct orientation of the plug. Insert the plug into the pump and install the two 12 mm socket head cap screws into the clamping plate. Slowly tighten the two screws alternating back and forth until the clamping plate is drawn down flush to the top of the cord boss on the pump. The two screws should be torqued until the plate is down to a point where **metal to metal** contact is made between the stainless steel plate and pump housing. (See Fig. 2)

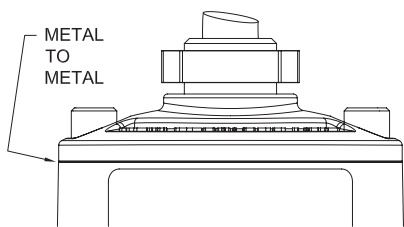

FIGURE 2a

The cord assembly mounted to the pump must not be modified in any way except for shortening to a specific application. Any splice between the pump and the control panel must be made in accordance with all applicable electric codes. It is recommended that a junction box (if used) be mounted outside the sump or be of at least Nema 6 or 6P construction with NEMA 6 or 6P watertight cord grips if located within the wet well. A water and vapor tight seal fitting **MUST** be used in conduit leaving the wet well to prevent moisture and gases from reaching the control panel. Prior to installation, the pump power cable should be inspected for nicks or damage. If damaged, the cord should be replaced before installation.

**CORD CLAMPING PLATE SHOULD BE DRAWN METAL TO METAL (50 FT/LBS BOLT TORQUE). IF A GAP EXISTS CONTINUE TO TIGHTEN BOLTS. DO NOT USE ANY TYPE OF SEALANT OR GREASE ON THE CORD ENTRY.**

**DO NOT USE THE POWER CORD TO LIFT PUMP.**

### B-4.1) Electrical Connections:

When the electrical connections are made, the lead wires from the power cable should be stripped so that the ground wire is at least two inches longer than the power leads. This will ensure that if the cable is inadvertently pulled out of the connection point, the ground wire will be the last lead to break the circuit.

### B-4.2) Wire Size:

If additional cable is required consult a qualified electrician for proper wire size. Voltage drop due to wire resistance between the pump and power connection point should be limited to 3% when additional cable is added.

### WARRANTY NOTE:



**Both the temperature sensor and moisture detection system must be connected to the motor circuitry such that the motor will be de-energized or sound alarm if excessive motor temperatures are reached and/or if water is detected in the seal chamber and/or motor chamber. Failure to have the above mentioned systems installed and operative, nullifies warranty.**

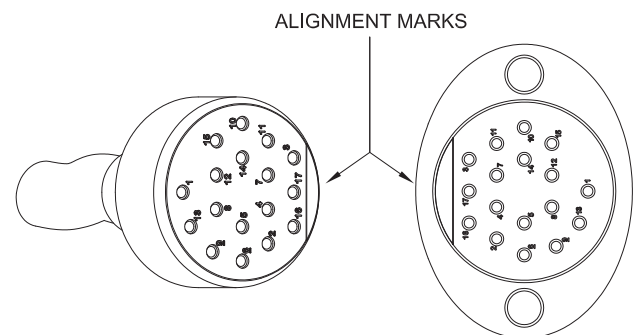

FIGURE 2b

MODEL NO	HP	VOLT	PH	Hz	RPM (Nom)	NEMA START CODE	FULL LOAD AMPS	1-2 SERVICE FACTOR AMPS	LOCKED ROTOR AMPS	CORD P/N ▲	CORD SIZE	CORD O.D.	WINDING RESISTANCE MAIN - - START	
3SHVC Pump	3.0	208	1	60	1750	D	14.9	18.5	59.1	125496	12/4 - 18/4	.86 ± .02	0.88 - 2.14	
		230				F	14.1	16.5	66.3	125496	12/4 - 18/4	.86 ± .02	0.88 - 2.14	
	3.0	208	3	60	1750	K	9.2	11.4	11.4	58.2	125496	12/4 - 18/4	.86 ± .02	1.08
		230						10.6	65.8	125496	12/4 - 18/4	.86 ± .02	1.08	
		460						5.3	32.9	125497	12/4 - 18/4	.86 ± .02	4.32	
	3.0	575	3	60	1750	N	4.5	4.9	4.9	37	125497	12/4 - 18/4	.86 ± .02	4.32
		208						D	27.2	35.6	99.9	125498	8/4 - 18/4	1.12 ± .02
	5.0	230	1	60	1750	F	25.4	30.2	30.2	112.4	125496	12/4 - 18/4	.86 ± .02	0.50 - - 2.66
		208						18.7	82.4	125496	12/4 - 18/4	.86 ± .02	0.72	
	5.0	230	3	60	1750	J	15	17.2	17.2	92.4	125496	12/4 - 18/4	.86 ± .02	0.72
		460						8.6	46.2	125497	12/4 - 18/4	.86 ± .02	2.88	
	5.0	575	3	60	1750	J	6	6.9	37	125497	12/4 - 18/4	.86 ± .02	4.32	

Moisture and Temperature sensor leads are integral to power cord.  
Winding Resistance ± 7.5% Winding resistance measured in OHMS @ 25°C (Between Lines) at motor leads.  
Pump rated for operation at ± 10% voltage at motor.  
▲ Cord Suffix: XC - 30 Feet, XF - 50 Feet, XJ - 75 Feet, or XL - 100 Feet  
▲ Cord sold separately.  
Single Phase pumps require start components to be included in panel. Provided with pump.

CHART 'A'

MODEL NO	HP	VOLT	PH	Hz	RPM (Nom)	NEMA START CODE	FULL LOAD AMPS	1.2 SERVICE FACTOR AMPS	LOCKED ROTOR AMPS	CORD P/N ▲	CORD SIZE	CORD O.D.	WINDING RESISTANCE MAIN - - START
3SHVR5072	5.0	208	1	60	3450	E	27.8	34.1	113.2	125498	8/4 - 18/4	1.12 ± .02	0.38 - - 1.66
		230				25.4	131.2	1.12 ± .02	0.38 - - 1.66				
3SHVR50N2	5.0	208	3	60	3450	J	14.9	17.8	85.4 / 95.2	125496	12/4 - 18/4	.86 ± .02	0.75
		230				13.7	16.0						
		460				6.9	8.0						
3SHVR5052	5.0	575	3	60	3450	J	5.5	6.4	38.1	125497	12/4 - 18/4	.86 ± .02	4.34
		208				24.2	28.0						
3SHVR75N2	7.5	230	3	60	3450	M	25.4	28.2	173.9 / 201.0	125496	12/4 - 18/4	.86 ± .02	0.40
		460				12.7	14.1						
		575				10.2	11.3						
3SHVR7552	7.5	208	3	60	3450	M	30.8	37.0	80.4	125497	12/4 - 18/4	.86 ± .02	2.47
		230				30.1	34.8						
3SHVR100N2	10.0	460	3	60	3450	K	15.1	17.4	100.5	125497	12/4 - 18/4	.86 ± .02	1.58
		575				12.1	13.9						
		208				10.4	12.1						
3SHVR10052	10.0	230	3	60	3450	K	10.7	11.9	80.4	125497	12/4 - 18/4	.86 ± .02	2.47
		460				7.4	8.3						
3SHVR2074	2.0	208	1	60	1750	G	7.4	8.3	59.1	125496	12/4 - 18/4	.86 ± .02	0.88 - 2.14
		230				7.4	8.0						
		460				3.7	4.0						
3SHVR20N4	2.0	208	3	60	1750	P	3.9	4.2	37.0	125497	12/4 - 18/4	.86 ± .02	4.32
		230				3.9	4.2						
3SHVR2054	2.0	575	3	60	1750	T	14.9	18.5	59.1	125496	12/4 - 18/4	.86 ± .02	0.88 - 2.14
		208				14.1	16.5						
		230				9.7	11.4						
3SHVR30N4	3.0	208	3	60	1750	K	9.2	10.6	58.2	125496	12/4 - 18/4	.86 ± .02	1.08
		230				4.6	5.3						
		460				4.5	4.9						
3SHVR3054	3.0	575	3	60	1750	N	27.2	35.6	99.9	125498	8/4 - 18/4	1.12 ± .02	0.50 - - 2.66
		208				25.4	30.2						
3SHVR5074	5.0	230	1	60	1750	D	15.8	18.7	82.4	125496	12/4 - 18/4	.86 ± .02	0.72
		460				15.0	17.2						
		575				7.5	8.6						
3SHVR50N4	5.0	230	3	60	1750	J	6.0	6.9	46.2	125497	12/4 - 18/4	.86 ± .02	2.88
		460				6.0	6.9						
3SHVR5054	5.0	575	3	60	1750	J	6.0	6.9	37.0	125497	12/4 - 18/4	.86 ± .02	4.32

**3SHVR Pump**

Moisture and Temperature sensor leads are integral to power cord.  
Winding Resistance ± 7.5% Winding resistance measured in OHMS @ 25°C (Between Lines) at motor leads.  
Pump rated for operation at ± 10% voltage at motor.

- ▲ Cord Suffix: XC - 30 Feet, XF - 50 Feet, XJ - 75 Feet, or XL - 100 Feet
- ▲ Cord sold separately.

Single Phase pumps require start components to be included in panel. Provided with pump.

**CHART 'B'**

**3SHVRA Pump**

MODEL NO	HP	VOLT	PH	Hz	RPM (Nom)	NEMA START CODE	FULL LOAD AMPS	1-2 SERVICE FACTOR AMPS	LOCKED ROTOR AMPS	CORD P/N ▲	CORD SIZE	CORD O.D.	WINDING RESISTANCE MAIN -- START
3SHVRA2074	2.0	208	1	60	1750	G	10.4	12.1	59.1	125496	12/4 - 18/4	.86 ± .02	0.88 -- 2.14
		230		60	1750	J	10.7	11.9	66.3	125496	12/4 - 18/4	.86 ± .02	0.88 -- 2.14
3SHVRA20N4	2.0	208	3	60	1750	P	7.4	8.3	58.2	125496	12/4 - 18/4	.86 ± .02	1.08
		230		60	1750		7.4	8.0	65.8	125496	12/4 - 18/4	.86 ± .02	1.08
		460		60	1750		3.7	4	32.9	125497	12/4 - 18/4	.86 ± .02	4.32
3SHVRA2054	2.0	575	3	60	1750	T	3.9	4.2	37.0	125497	12/4 - 18/4	.86 ± .02	4.32
		208		60	1750	D	14.9	18.5	37.0	125496	12/4 - 18/4	.86 ± .02	0.88 -- 2.14
3SHVRA3074	3.0	230	1	60	1750	F	14.1	16.5	66.3	125496	12/4 - 18/4	.86 ± .02	0.88 -- 2.14
		208		60	1750	9.7	11.4	58.2	125496	12/4 - 18/4	.86 ± .02	1.08	
3SHVRA30N4	3.0	230	3	60	1750	K	9.2	10.6	65.8	125496	12/4 - 18/4	.86 ± .02	1.08
		460		60	1750		4.6	5.3	32.9	125497	12/4 - 18/4	.86 ± .02	4.32
		575		60	1750		4.5	4.9	37.0	125497	12/4 - 18/4	.86 ± .02	4.32
3SHVRA5074	5.0	208	1	60	1750	D	27.2	35.6	99.9	125498	8/4 - 18/4	1.12 ± .02	0.50 -- 2.66
		230		60	1750	F	25.4	30.2	112.4	125498	12/4 - 18/4	1.12 ± .02	0.50 -- 2.66
3SHVRA50N4	5.0	208	3	60	1750	J	15.8	18.7	82.4	125496	12/4 - 18/4	.86 ± .02	0.72
		230		60	1750		15	17.2	92.4	125496	12/4 - 18/4	.86 ± .02	0.72
		460		60	1750		7.5	8.6	46.2	125497	12/4 - 18/4	.86 ± .02	2.88
3SHVRA5054	5.0	575	3	60	1750	J	6	6.9	37.0	125497	12/4 - 18/4	.86 ± .02	4.32
		208		60	1750	23.8	28.5	105.9	125496	12/4 - 18/4	.86 ± .02	0.43	
3SHVRA75N4	7.5	230	3	60	1750	H	23.7	27.2	123.6	125496	12/4 - 18/4	.86 ± .02	0.43
		460		60	1750		11.9	13.6	61.8	125497	12/4 - 18/4	.86 ± .02	1.72
		575		60	1750		9.5	10.9	49.4	125497	12/4 - 18/4	.86 ± .02	2.69

Moisture and Temperature sensor leads are integral to power cord.

Winding Resistance ± 7.5% Winding resistance measured in OHMS @ 25°C (Between Lines) at motor leads.  
 Pump rated for operation at ± 10% voltage at motor.

▲ Cord Suffix: XC - 30 Feet, XF - 50 Feet, XJ - 75 Feet, or XL - 100 Feet

▲ Cord sold separately.

Single Phase pumps require start components to be included in panel. Provided with pump.

**CHART 'C'**



MODEL NO	HP	VOLT	PH	Hz	RPM (Nom)	NEMA START CODE	FULL LOAD AMPS	1-2 SERVICE FACTOR AMPS	LOCKED ROTOR AMPS	CORD P/N ▲	CORD SIZE	CORD O.D.	WINDING RESISTANCE MAIN - - START		
<b>3SHMPA Pump</b>	3SHMPA3074	208	1	60	1750	D	14.9	18.5	59.1	125496	12/4 - 18/4	.86 ± .02	0.88 - 2.14		
		230				14.1	16.5	66.3							
	3SHMPA30N4	208	3	60	1750	K	9.7	11.4	58.2 / 65.8	32.9	125497	12/4 - 18/4	.86 ± .02	1.08	
		230					9.2							10.6	1.08
		460					4.6							5.3	4.32
	3SHMPA3054	575	3	60	1750	N	4.5	4.9	37.0	37.0	125497	12/4 - 18/4	.86 ± .02	4.32	
		208					27.2							35.6	99.9
	3SHMPA5074	230	1	60	1750	F	25.4	30.2	112.4	112.4	125498	8/4 - 18/4	1.12 ± .02	0.50 -- 2.66	
		208					15.8							18.7	0.72
		460					15.0							17.2	82.4 / 92.4
	3SHMPA50N4	575	3	60	1750	J	7.5	8.6	46.2	46.2	125497	12/4 - 18/4	.86 ± .02	0.72	
		230					6.0							6.9	2.88
460		6.0					6.9							37.0	4.32
3SHMPA75N4	208	3	60	1750	H	23.8	28.5	105.9 / 123.6	105.9 / 123.6	125496	12/4 - 18/4	.86 ± .02	0.43		
	230					23.7							27.2	0.43	
	460					11.9							13.6	61.8	1.72
3SHMPA7554	7.5	575	3	60	1750	H	9.5	10.9	49.4	125497	12/4 - 18/4	.86 ± .02	2.69		

Moisture and Temperature sensor leads are integral to power cord.

Winding Resistance ± 7.5% Winding resistance measured in OHMS @ 25°C (Between Lines) at motor leads.

Pump rated for operation at ± 10% voltage at motor.

▲ Cord Suffix: XC - 30 Feet, XF - 50 Feet, XJ - 75 Feet, or XL - 100 Feet

▲ Cord sold separately.

Single Phase pumps require start components to be included in panel. Provided with pump.

**4SHVA Pump**

MODEL NO	HP	VOLT	PH	Hz	RPM (Nom)	NEMA START CODE	FULL LOAD AMPS	1-2 SERVICE FACTOR AMPS	LOCKED ROTOR AMPS	CORD P/N ▲	CORD SIZE	CORD O.D.	WINDING RESISTANCE MAIN - - START
4SHVA75N2	7.5	208	3	60	3450	M	24.2	28.0	173.9 / 201.0	125496	12/4 - 18/4	.86 ± .02	0.40
		230											
		460											
4SHVA7552	7.5	575	3	60	3450	M	10.2	11.3	80.4	125497	12/4 - 18/4	.86 ± .02	2.47
		208											
		230											
4SHVA100N2	10.0	208	3	60	3450	K	30.8	37.0	173.9 / 201.0	125498	8/4 - 18/4	1.12 ± .02	0.40
		230											
		460											
4SHVA10052	10.0	575	3	60	3450	K	12.1	13.9	80.4	125497	12/4 - 18/4	.86 ± .02	2.47
		208											
		230											
4SHVA2074	2.0	208	1	60	1750	G	10.4	12.1	59.1	125496	12/4 - 18/4	.86 ± .02	0.88 - 2.14
		230											
		460											
4SHVA20N4	2.0	208	3	60	1750	P	7.4	8.3	58.2	125496	12/4 - 18/4	.86 ± .02	1.08
		230											
		460											
4SHVA2054	2.0	575	3	60	1750	T	3.7	4.0	32.9	125497	12/4 - 18/4	.86 ± .02	4.32
		208											
		230											
4SHVA3074	3.0	208	1	60	1750	D	14.9	118.5	59.1	125496	12/4 - 18/4	.86 ± .02	0.88 - 2.14
		230											
		460											
4SHVA30N4	3.0	208	3	60	1750	K	9.7	11.4	58.2	125496	12/4 - 18/4	.86 ± .02	1.08
		230											
		460											
4SHVA3054	3.0	575	3	60	1750	N	4.5	4.9	37.0	125497	12/4 - 18/4	.86 ± .02	4.32
		208											
		230											
4SHVA5074	5.0	208	1	60	1750	D	27.2	35.6	99.9	125498	8/4 - 18/4	1.12 ± .02	0.50 - - 2.66
		230											
		460											
4SHVA50N4	5.0	208	3	60	1750	J	15.8	18.7	82.4	125496	12/4 - 18/4	.86 ± .02	0.72
		230											
		460											
4SHVA5054	5.0	575	3	60	1750	J	7.5	8.6	46.2	125497	12/4 - 18/4	.86 ± .02	2.88
		208											
		230											

Moisture and Temperature sensor leads are integral to power cord.  
Winding Resistance ± 7.5% Winding resistance measured in OHMS @ 25°C (Between Lines) at motor leads.  
Pump rated for operation at ± 10% voltage at motor.  
▲ Cord Suffix: XC - 30 Feet, XF - 50 Feet, XJ - 75 Feet, or XL - 100 Feet  
▲ Cord sold separately.  
Single Phase pumps require start components to be included in panel. Provided with pump.

**CHART 'E'**

MODEL NO	HP	VOLT	PH	Hz	RPM (Nom)	NEMA START CODE	FULL LOAD AMPS	1-2 SERVICE FACTOR AMPS	LOCKED ROTOR AMPS	CORD P/N ▲	CORD SIZE	CORD O.D.	WINDING RESISTANCE MAIN - - START
4SHVB Pump	4SHVB75N2	208	3	60	3450	M	24.2	28.0	173.9 / 201.0	125496	12/4 - 18/4	.86 ± .02	0.40
		230					28.2	125496	12/4 - 18/4	.86 ± .02	0.40		
		460					14.1	100.5	125497	12/4 - 18/4	.86 ± .02	1.58	
	4SHVB7552	575	3	60	3450	M	10.2	11.3	80.4	125497	12/4 - 18/4	.86 ± .02	2.47
		208					37.0	173.9 / 201.0	125498	8/4 - 18/4	1.12 ± .02	0.40	
		230					34.8	125498	8/4 - 18/4	1.12 ± .02	0.40		
	4SHVB100N2	460	3	60	3450	K	15.1	17.4	100.5	125497	12/4 - 18/4	.86 ± .02	1.58
		575					13.9	80.4	125497	12/4 - 18/4	.86 ± .02	2.47	
		208					12.1	59.1	125496	12/4 - 18/4	.86 ± .02	0.88 - 2.14	
	4SHVB2074	230	1	60	1750	J	10.4	11.9	66.3	125496	12/4 - 18/4	.86 ± .02	0.88 - 2.14
		208					8.3	58.2	125496	12/4 - 18/4	.86 ± .02	1.08	
		460					4.0	65.8	125496	12/4 - 18/4	.86 ± .02	1.08	
4SHVB20N4	575	3	60	1750	P	3.7	4.0	32.9	125497	12/4 - 18/4	.86 ± .02	4.32	
	208					4.2	37.0	125497	12/4 - 18/4	.86 ± .02	4.32		
	230					18.5	59.1	125496	12/4 - 18/4	.86 ± .02	0.88 - 2.14		
4SHVB2054	208	1	60	1750	D	14.9	16.5	66.3	125496	12/4 - 18/4	.86 ± .02	0.88 - 2.14	
	230					11.4	58.2	125496	12/4 - 18/4	.86 ± .02	1.08		
	460					10.6	65.8	125496	12/4 - 18/4	.86 ± .02	1.08		
4SHVB3074	575	3	60	1750	N	4.6	5.3	32.9	125497	12/4 - 18/4	.86 ± .02	4.32	
	208					4.9	37.0	125497	12/4 - 18/4	.86 ± .02	4.32		
	230					35.6	99.9	125498	8/4 - 18/4	1.12 ± .02	0.50 - - 2.66		
4SHVB30N4	208	1	60	1750	F	25.4	30.2	112.4	125496	12/4 - 18/4	.86 ± .02	0.50 - - 2.66	
	230					18.7	82.4	125496	12/4 - 18/4	.86 ± .02	0.72		
	460					17.2	92.4	125496	12/4 - 18/4	.86 ± .02	0.72		
4SHVB50N4	575	3	60	1750	J	7.5	8.6	46.2	125497	12/4 - 18/4	.86 ± .02	2.88	
	208					6.9	37.0	125497	12/4 - 18/4	.86 ± .02	4.32		
	230					28.5	105.9	125496	12/4 - 18/4	.86 ± .02	0.43		
4SHVB5054	460	3	60	1750	H	23.7	27.2	123.6	125496	12/4 - 18/4	.86 ± .02	0.43	
	575					13.6	61.8	125497	12/4 - 18/4	.86 ± .02	1.72		
	208					10.9	49.4	125497	12/4 - 18/4	.86 ± .02	2.69		
4SHVB7554	208	3	60	1750	H	32.2	41.4	105.9	125498	8/4 - 18/4	.86 ± .02	0.43	
	230					35.6	123.6	125498	8/4 - 18/4	1.12 ± .02	0.43		
	460					17.8	61.8	125497	12/4 - 18/4	.86 ± .02	1.72		
4SHVB100N4	575	3	60	1750	E	11.9	14.2	49.4	125497	12/4 - 18/4	.86 ± .02	2.69	
	208					10.0	10.0	125497	12/4 - 18/4	.86 ± .02	2.69		
	230					10.0	10.0	125497	12/4 - 18/4	.86 ± .02	2.69		
4SHVB10054	460	3	60	1750	E	14.9	17.8	61.8	125497	12/4 - 18/4	.86 ± .02	1.72	
	575					11.9	49.4	125497	12/4 - 18/4	.86 ± .02	2.69		
	208					10.0	10.0	125497	12/4 - 18/4	.86 ± .02	2.69		

Moisture and Temperature sensor leads are integral to power cord.  
Winding Resistance ± 7.5% Winding resistance measured in OHMS @ 25°C (Between Lines) at motor leads.  
Pump rated for operation at ± 10% voltage at motor.  
▲ Cord Suffix: XC - 30 Feet, XF - 50 Feet, XJ - 75 Feet, or XL - 100 Feet  
▲ Cord sold separately.  
Single Phase pumps require start components to be included in panel. Provided with pump.

CHART 'F'

MODEL NO	HP	VOLT	PH	Hz	RPM (Nom)	NEMA START CODE	FULL LOAD AMPS	SERVICE FACTOR	SERVICE FACTOR AMPS	LOCKED ROTOR AMPS	CORD P/N ▲	CORD SIZE	CORD O.D.	WINDING RESISTANCE MAIN - - START
4SHVBA Pump	4SHVBA5074*	208	1	60	1750	D	27.2	1.2	35.6	99.9	125498	8/4 - 18/4	1.12 ± .02	0.50 - 2.66
		230					25.4	1.2	30.2	112.4	125496	12/4 - 18/4	.86 ± .02	0.50 - 2.66
		208					15.8	1.2	18.7	82.4	125496	12/4 - 18/4	.86 ± .02	0.72
	4SHVBA50N4*	230	3	60	1750	J	15.0	1.2	17.2	92.4	125496	12/4 - 18/4	.86 ± .02	0.72
		460					7.5	1.2	8.6	46.2	125497	12/4 - 18/4	.86 ± .02	2.88
		575					6.0	1.2	6.9	37.0	125497	12/4 - 18/4	.86 ± .02	4.32
	4SHVBA75N4	208	3	60	1750	H	23.8	1.2	28.5	105.9	125496	12/4 - 18/4	.86 ± .02	0.43
		230					23.7	1.2	27.2	123.6	125496	12/4 - 18/4	.86 ± .02	0.43
		460					11.9	1.2	13.6	61.8	125497	12/4 - 18/4	.86 ± .02	1.72
	4SHVBA7554	575	3	60	1750	H	9.5	1.2	10.9	49.4	125497	12/4 - 18/4	.86 ± .02	2.69
		208					32.2	1.2	41.4	105.9	125498	8/4 - 18/4	1.12 ± .02	0.43
		230					29.8	1.2	35.6	123.6	125498	8/4 - 18/4	1.12 ± .02	0.43
	4SHVBA100N4	460	3	60	1750	E	14.9	1.2	17.8	61.8	125497	12/4 - 18/4	.86 ± .02	1.72
		575					11.9	1.2	14.2	49.4	125497	12/4 - 18/4	.86 ± .02	2.69

Moisture and Temperature sensor leads are integral to power cord.  
Winding Resistance ± 7.5% Winding resistance measured in OHMS @ 25°C (Between Lines) at motor leads.  
Pump rated for operation at ± 10% voltage at motor.

▲ Cord Suffix: XC - 30 Feet, XF - 50 Feet, XJ - 75 Feet, or XL - 100 Feet

▲ Cord sold separately.

\* Select impeller diameter when ordering.

Single Phase pumps require start components to be included in panel. Provided with pump.

CHART 'G'

MODEL NO	HP	VOLT	PH	Hz	RPM (Nom)	NEMA START CODE	FULL LOAD AMPS	1.2 SERVICE FACTOR AMPS	LOCKED ROTOR AMPS	CORD P/N ▲	CORD SIZE	CORD O.D.	WINDING RESISTANCE MAIN -- START
4SHMS Pump	4SHMS3074	208	1	60	1750	D	14.9	18.5	59.1	125496	12/4 - 18/4	.86 ± .02	0.88 -- 2.14
		230				16.5	66.3	.86 ± .02					
	4SHMS30N4	208	3	60	1750	K	9.7	11.4	58.2 / 65.8	125496	12/4 - 18/4	.86 ± .02	1.08
		230					10.6	1.08					
	4SHMS3054	208	3	60	1750	N	4.6	5.3	32.9	125497	12/4 - 18/4	.86 ± .02	4.32
		460					4.9	37.0	.86 ± .02				
	4SHMS5074	208	1	60	1750	D	27.2	35.6	99.9	125498	8/4 - 18/4	1.12 ± .02	0.50 -- 2.66
		230					30.2	112.4	1.12 ± .02				
	4SHMS50N4	208	3	60	1750	J	15.8	18.7	82.4 / 92.4	125496	12/4 - 18/4	.86 ± .02	0.72
		230					17.2	46.2	.86 ± .02				
	4SHMS5054	208	3	60	1750	J	7.5	8.6	46.2	125497	12/4 - 18/4	.86 ± .02	2.88
		460					6.9	37.0	.86 ± .02				
4SHMS75N4	208	3	60	1750	H	23.8	28.5	105.9 / 123.6	125496	12/4 - 18/4	.86 ± .02	0.43	
	230					27.2	61.8	.86 ± .02					
4SHMS7554	208	3	60	1750	H	11.9	13.6	61.8	125497	12/4 - 18/4	.86 ± .02	1.72	
	460					10.9	49.4	.86 ± .02					
4SHMC Pump	4SHMC5074	208	1	60	1750	D	27.2	35.6	99.9	125498	8/4 - 18/4	1.12 ± .02	0.50 -- 2.66
		230				30.2	112.4	1.12 ± .02					
	4SHMC50N4	208	3	60	1750	J	15.8	18.7	82.4/92.4	125496	12/4 - 18/4	.86 ± .02	0.72
		230					17.2	46.2	.86 ± .02				
	4SHMC5054	208	3	60	1750	J	7.5	8.6	46.2	125497	12/4 - 18/4	.86 ± .02	2.88
		460					6.9	37.0	.86 ± .02				
	4SHMC75N4	208	3	60	1750	H	23.8	28.5	105.9 / 123.6	125496	12/4 - 18/4	.86 ± .02	0.43
		230					27.2	61.8	.86 ± .02				
	4SHMC7554	208	3	60	1750	H	11.9	13.6	61.8	125497	12/4 - 18/4	.86 ± .02	1.72
		460					10.9	49.4	.86 ± .02				
	4SHMC100N4	208	3	60	1750	E	32.2	41.4	105.9 / 123.6	125498	8/4 - 18/4	1.12 ± .02	0.43
		230					35.6	61.8	.86 ± .02				
4SHMC10054	208	3	60	1750	E	14.9	17.8	61.8	125497	12/4 - 18/4	.86 ± .02	1.72	
	460					14.2	49.4	.86 ± .02					

Moisture and Temperature sensor leads are integral to power cord.  
Winding Resistance ± 7.5% Winding resistance measured in OHMS @ 25°C (Between Lines) at motor leads.  
Pump rated for operation at ± 10% voltage at motor.  
▲ Cord Suffix: XC - 30 Feet, XF - 50 Feet, XJ - 75 Feet, or XL - 100 Feet  
▲ Cord sold separately.  
Single Phase pumps require start components to be included in panel. Provided with pump.

CHART 'H'

MODEL NO	HP	VOLT	PH	Hz	RPM (Nom)	NEMA START CODE	FULL LOAD AMPS	1-2 SERVICE FACTOR AMPS	LOCKED ROTOR AMPS	CORD P/N ▲	CORD SIZE	CORD O.D.	WINDING RESISTANCE MAIN - - START					
4SHDF Pump	4SHDF3074	208	1	60	1750	D	14.9	18.5	59.1	125496	12/4 - 18/4	.86 ± .02	0.88 - - 2.14					
		230				16.5	66.3	.86 ± .02										
	4SHDF30N4	208	3	60	1750	K	9.7	11.4	58.2 / 65.8		125496	12/4 - 18/4	.86 ± .02	1.08				
		230													10.6	125496	12/4 - 18/4	.86 ± .02
		460													5.3	125497	12/4 - 18/4	.86 ± .02
		575													4.9	125497	12/4 - 18/4	.86 ± .02
	4SHDF5074	208	1	60	1750	D	27.2	35.6	99.9 / 112.4	125498	8/4 - 18/4	1.12 ± .02	0.50 - - 2.66					
		230					30.2	1.12 ± .02										
	4SHDF50N4	208	3	60	1750	J	15.0	17.2	82.4 / 92.4		125496	12/4 - 18/4	.86 ± .02	0.72				
		230													8.6	125497	12/4 - 18/4	.86 ± .02
		460													6.9	125497	12/4 - 18/4	.86 ± .02
		575													28.5	125496	12/4 - 18/4	.86 ± .02
4SHDF75N4	208	3	60	1750	H	23.8	27.2	105.9 / 123.6		125496	12/4 - 18/4	.86 ± .02	0.43					
	230					13.6	125497							12/4 - 18/4	.86 ± .02			
	460					10.9	125497							12/4 - 18/4	.86 ± .02			
	575					41.4	125498							8/4 - 18/4	1.12 ± .02			
4SHDF100N4	208	3	60	1750	E	29.8	35.6	105.9 / 123.6		125498	12/4 - 18/4	1.12 ± .02	0.43					
	230					17.8	125497							12/4 - 18/4	.86 ± .02			
	460					14.2	125497							12/4 - 18/4	.86 ± .02			
	575					11.9	125497							12/4 - 18/4	.86 ± .02			

MODEL NO	HP	VOLT	PH	Hz	RPM (Nom)	NEMA START CODE	FULL LOAD AMPS	1-2 SERVICE FACTOR AMPS	LOCKED ROTOR AMPS	CORD P/N ▲	CORD SIZE	CORD O.D.	WINDING RESISTANCE MAIN - - START					
4SHDG Pump	4SHDG5074	208	1	60	1750	D	27.2	35.6	99.9	125498	8/4 - 18/4	1.12 ± .02	0.50 - - 2.66					
		230				30.2	112.4	1.12 ± .02										
	4SHDG50N4	208	3	60	1750	J	15.0	17.2	82.4 / 92.4		125496	12/4 - 18/4	.86 ± .02	0.72				
		230													8.6	125496	12/4 - 18/4	.86 ± .02
		460													6.9	125497	12/4 - 18/4	.86 ± .02
		575													28.5	125497	12/4 - 18/4	.86 ± .02
	4SHDG75N4	208	3	60	1750	H	23.8	27.2	105.9 / 123.6		125496	12/4 - 18/4	.86 ± .02	0.43				
		230					13.6	125497							12/4 - 18/4	.86 ± .02		
		460					10.9	125497							12/4 - 18/4	.86 ± .02		
		575					41.4	125497							12/4 - 18/4	.86 ± .02		
	4SHDG100N4	208	3	60	1750	E	29.8	35.6	105.9 / 123.6		125498	8/4 - 18/4	1.12 ± .02	0.43				
		230					17.8	125497							12/4 - 18/4	.86 ± .02		
460		14.2					125497	12/4 - 18/4							.86 ± .02			
575		11.9					125497	12/4 - 18/4							.86 ± .02			

Moisture and Temperature sensor leads are integral to power cord.  
Winding Resistance ± 7.5% Winding resistance measured in OHMS @ 25°C (Between Lines) at motor leads.  
Pump rated for operation at ± 10% voltage at motor.  
▲ Cord Suffix: XC - 30 Feet, XF - 50 Feet, XJ - 75 Feet, or XL - 100 Feet  
▲ Cord sold separately.  
Single Phase pumps require start components to be included in panel. Provided with pump.

CHART 'J'

THREE PHASE 460-575 VOLT AC (orange molded plug)	
Power Cable	Motor Lead ID
Green (Ground)	Green
Black	1
Red	2
White	3
Jumpered Inside Cord Automatically (No user jump-ering required)	T4 & T7 Together T5 & T8 Together T6 & T9 Together

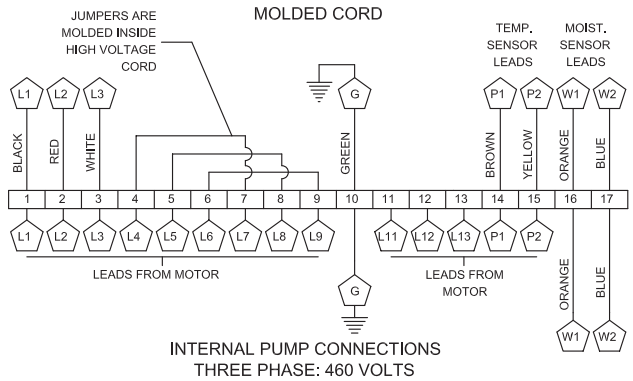

MOISTURE AND TEMPERATURE SENSORS	
Power Cable	Lead ID
Brown	P1 (Temperature Sensor)
Yellow	P2 (Temperature Sensor)
Orange	W1 (Moisture Sensor)
Blue	W2 (Moisture Sensor)

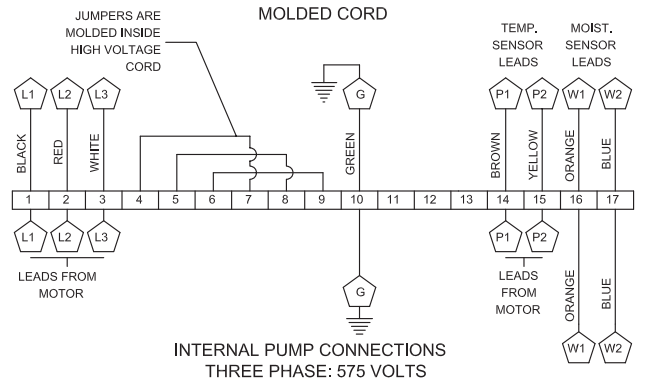

THREE PHASE 208-230 VOLT AC (black molded plug)	
Power Cable	Motor Lead ID
Green (Ground)	Green
Black	1
Red	2
White	3
Jumpered Inside Cord Automatically (No user jump-ering required)	T4, T5 & T6 Together T11 & T7 Together T13 & T9 Together T12 & T8 Together

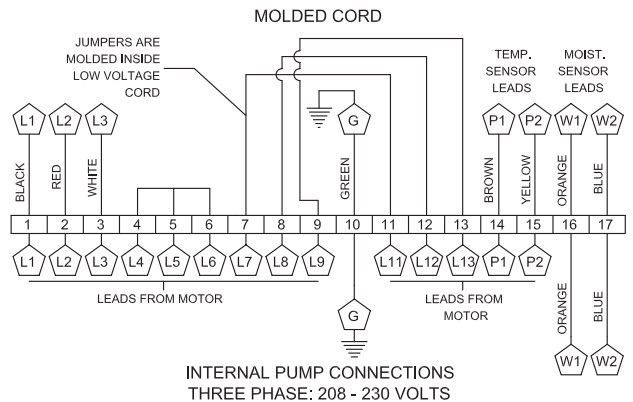

SINGLE PHASE 208-230 VOLT AC (black molded plug)	
Power Cable	Motor Lead ID
Green (Ground)	Green
Black	1 (Run)
Red	2 (Start)
White	3 (Common)
Jumpered Inside Cord Automatically (No user jump-ering required)	T4, T5 & T6 Together T11 & T7 Together T13 & T9 Together T12 & T8 Together

\* Requires Start/Run Caps and Start Relay in panel \*

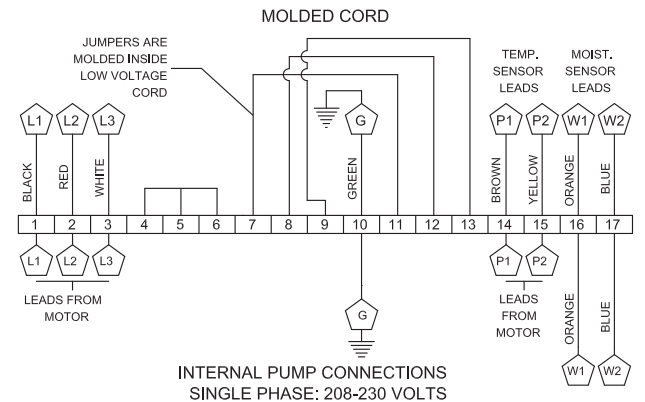

FIGURE 3

**External Ground Note:**

(Grd symbol) An external ground screw is provided on the side of the motor cap which can be used for supplemental bonding connection where local codes permit or require such connection.

## TYPICAL POWER CIRCUIT

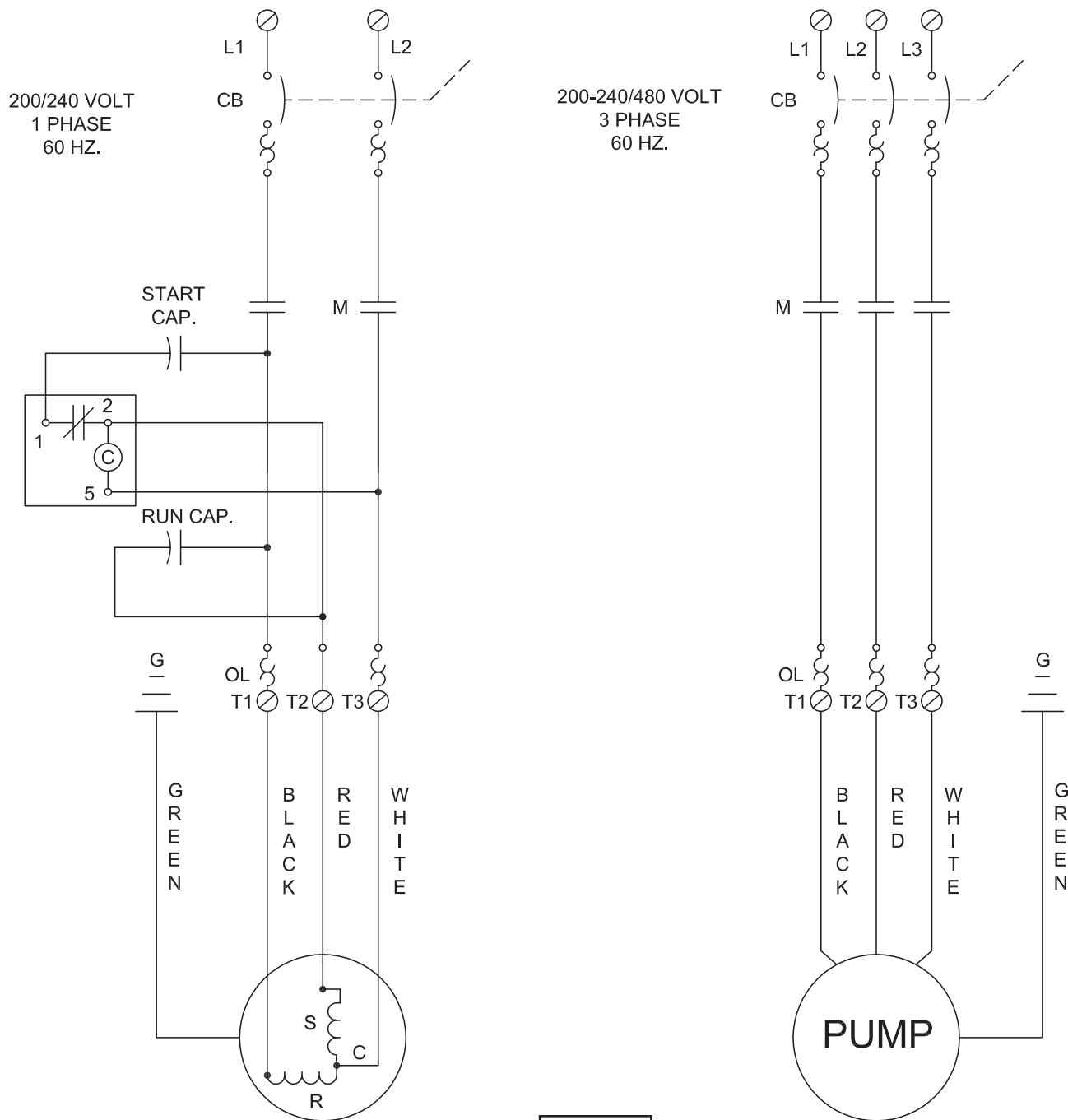

FIGURE 3b

Single Phase Cap Chart					
HP	RPM	Cap Kit	Start Relay	Start Cap	Run Cap
5	1750	133042	Mars 64	440MFD @ 330V	50MFD @370V
5	3450	141361	Mars 64	297MFD @ 330V	40MFD @440V
3	1750				
2	1750				

Single Phase Start Components



## TYPICAL THERMAL PROTECTION WIRING DIAGRAM

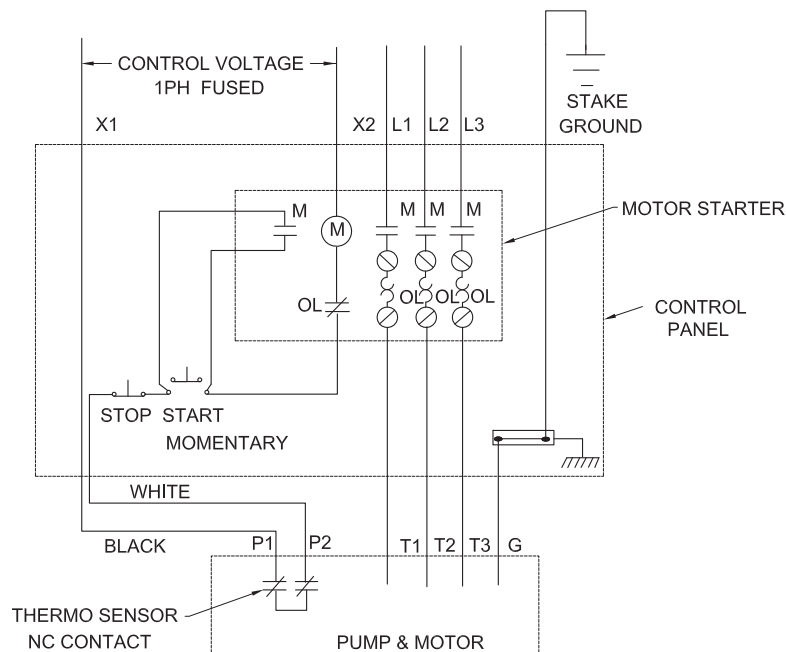

**FIGURE 4**

### B-4.3) Overload Protection:

Current sensing overloads must be provided in the pump control panel and should be properly sized for the full load current of the pump. Three normally closed (N/C) thermal sensors wired in series (one per phase) are embedded in the motor windings and will detect excessive heat in the event an overload condition occurs which will then trip and stop the pump when wired in series with the pump contactor control circuit. The thermal sensor leads marked P1 and P2 **MUST** be connected in series with the stop button of the pilot circuit of the magnetic motor controller located in the control panel so that the thermostat will open the circuit before dangerous temperatures are reached. A manual momentary start switch is required to prevent the automatic restarting of the motor when the thermostat resets. For a typical wiring diagram, refer to Figure 4.

In the event of an over temperature condition, the source of this condition should be determined and rectified before the pump is put back into normal operation. **DO NOT LET THE PUMP CYCLE OR RUN IF AN OVER TEMPERATURE CONDITION OCCURS!**

If current through the temperature sensor exceeds the values listed, an intermediate control circuit relay must be used to reduce the current or the sensor will not work properly.

TEMPERATURE SENSOR ELECTRICAL RATINGS		
Volts	Continuous Amperes	Inrush Amperes
110-120	3.00	20.0
220-240	2.00	18.0

### B-4.4) Moisture Sensors:

A normally open (N/O) detector is installed in the pump seal chamber, which will detect any moisture present, and a continuity test resistor built into the motor. The test resistor is rated 1 watt at 330K ohms. The moisture sensors **MUST** be connected to moisture detector control in the control panel which includes a continuity test circuit, see Figure 4 for typical wiring diagram. The normally closed (N/C) contact of the moisture detector **MUST** be connected in series with the stop button of the pilot circuit of the magnetic motor controller. Wiring must be provided from the moisture detector sensor probe leads of the motor designated W1 and W2 to terminals 9 and 10 of the 2800-XXX control. Terminal pair 1-2 must be continuously energized from an A-C supply line of electrical characteristics shown on the data table. In the event of moisture detection, the pump should be pulled and the source of the failure located and repaired. **IF MOISTURE DETECTION HAS OCCURRED, SCHEDULE MAINTENANCE AS SOON AS POSSIBLE !**

### B-4.5) Control Panel and Electrical System:

The control panel and the electrical system **MUST** be properly designed and wired to include at least, but not limited to the following;

- a. Proper grounding per NEC.
- b. A temperature sensing circuit (See Fig. 4)
- c. A moisture detection circuit with continuity test circuit (See Fig. 5)
- d. A level control system.
- e. A main power manual disconnect and lock out.
- f. A motor starter and overload system.
- g. Start Capacitor, Run Capacitor & Start Relay (single phase only).

## TYPICAL WIRING DIAGRAM FOR MOISTURE SENSOR RELAY

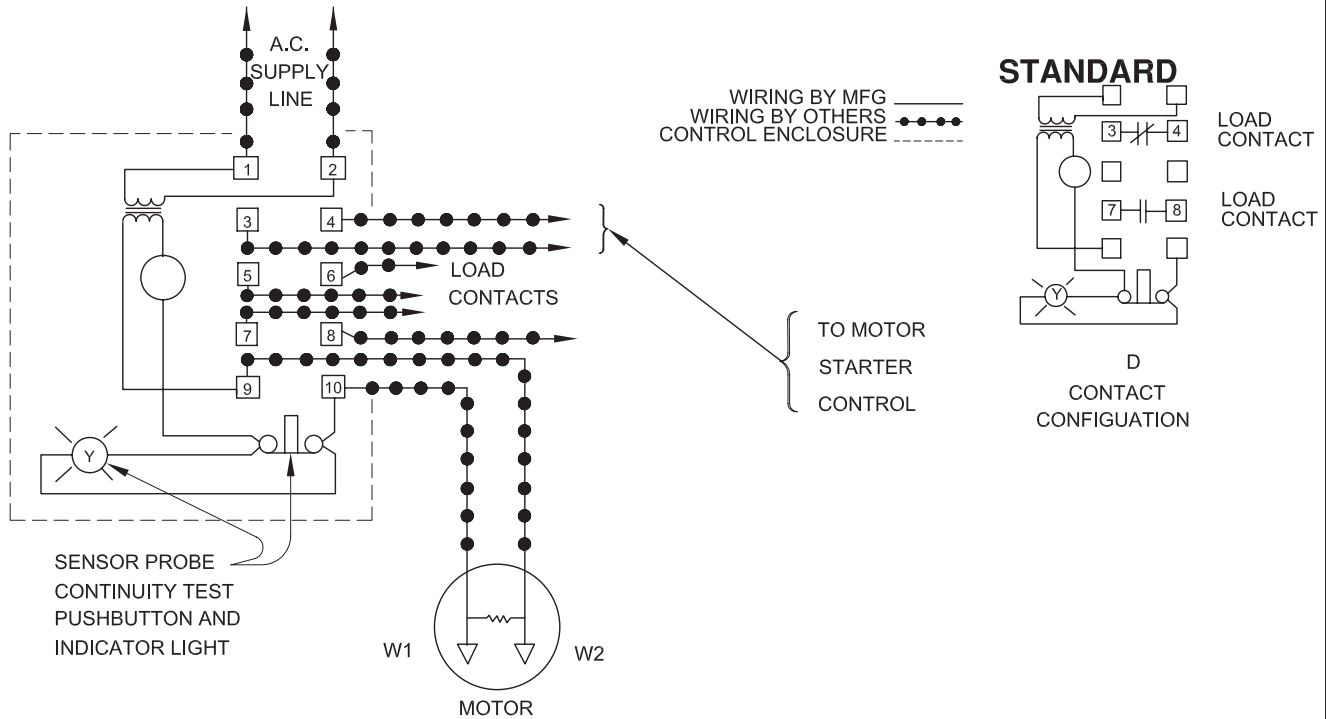

FIGURE 5

### B-5) When Used with a Variable Speed Drive:

Maximum turndown should not exceed 2:1. Drive should be set to operate in constant torque mode.

It is advisable that all three phase control panels be purchased from the factory.

## SECTION: C START-UP OPERATION

### C-1) Check Voltage and Phase:

Before operating pump, compare the voltage and phase information stamped on the pump's identification plate to the available power.

### C-2) Check Pump Rotation:

Before putting pump into service for the first time, the motor rotation must be checked. Improper motor rotation can result in poor pump performance and can damage the motor and/or pump. To check the rotation, suspend the pump freely, momentarily apply power and observe the "kickback". "Kickback" should always be in a counter-clockwise direction as viewed from the top of the pump motor housing and will always be in the opposite direction of the rotation arrows cast in the pump volute.

### C-2.1) Incorrect Rotation for Three-Phase Pumps:

In the event that the rotation is incorrect for a three-phase installation, interchange any two power cable leads at the control box. Recheck the "kickback" rotation again by momentarily applying power.

### C-2.2) Test Procedure For Moisture Sensor Control:

With a moisture detection control, a normally closed push button and neon indicating lamp is typically provided as a means of checking the moisture sensing components. When the push button is depressed, the indicating lamp will be illuminated to indicate (A) power is supplied to the control, (B) the control is operative, and (C) wiring to the moisture sensing probes in the motor is intact. This procedure should be performed periodically to confirm integrity of the circuit.

### C-3) Start-Up Report:

Included at the end of this manual is one start-up report sheet, this sheet is to be completed as applicable. Return a copy to Barnes and store the second in the control panel or with the pump manual. It is important to record this data at initial start-up since it will be useful to refer to should servicing the pump be required in the future.

### C-3.1) Identification Plate:

Record the numbers from the pump's identification plate on the START-UP REPORT provided at the end of the manual for future reference.

**C-3.2) Insulation Test:**

Before the pump is put into service, an insulation (megger) test should be performed on the motor. The resistance values (ohms) as well as the voltage (volts) and current (amps) should be recorded on the start-up report. Pumps/systems with an insulation value of less than 5 M-Ohms should be investigated for moisture or damaged cables before proceeding.

**C-3.3) Pump-Down Test:**

After the pump has been properly wired and lowered into the basin, sump or lift station, it is advisable to check the system by filling with liquid and allowing the pump to operate through it's pumping cycle. The time needed to empty the system, or pump-down time along with the volume of water, should be recorded on the start-up report.

**IMPORTANT! THE MAXIMUM ALLOWABLE STARTS PER HOUR IS 15, EVENLY SPACED.**

**SECTION D: PREVENTATIVE MAINTENANCE**

As the motor and seal chamber are oil-filled, no lubrication or other maintenance is required, and generally Barnes Pumps will give very reliable service and can be expected to operate for years of normal sewage pumping without failing. However, as with any mechanical piece of equipment a preventive maintenance program is recommended and suggested to include the following checks:

- 1) Test moisture detector control "Test Switch" for continuity of circuit. Water in the seal chamber will energize a seal leak warning light at the control panel. This is a warning light only and does not stop the motor. It indicates the seal has leaked and must be repaired. This should be done within 2 or 3 weeks to prevent further damage. See section C-2.2.
- 2) Inspect impeller and body for excessive build-up or clogging and repair as required per section E-2.
- 3) Inspect outer shaft seal and replace as required per section E-3.
- 4) Check motor for ground leakage and proper amp draw.

**SECTION E: SERVICE AND REPAIR**

NOTE: All item numbers in ( ) refer to Figures 10, 11 & 12.



**WARNING ! - Electrical power to the pump motors must be disconnected and locked out to prevent any dangerous electrical hazards or personnel danger before any service work is done to the pump.**



**CAUTION ! - Operating pump builds up heat and pressure; allow time for pump to cool to room temperature before handling or servicing.**

**E-1) Lubrication**

**E-1.1) Checking Oil**

1. Place pump on it's side, and drain oil into a clean, dry container.
2. Check oil for contamination using an oil tester with a range to 30Kilovolts breakdown.
3. If oil is found to be clean and uncontaminated (measure above 15 KV. breakdown), refill the seal chamber as per section E-1.2.
4. If oil is found to be dirty or contaminated (or measures below 15 KV. breakdown), the pump must be carefully inspected for leaks at the shaft seal (4), before refilling with oil. To locate the leak, perform a pressure test as per section E-1.3. After leak is repaired, refill with new oil as per section E-1.2.

**E-1.2) Replacing Oil:**

Seal Chamber - Drain all oil from seal chamber and dispose of properly. Refill with (see parts list for amount) (Oil amount for seal chamber for 18 frame pumps = 47oz. +/- 1 oz.) new cooling oil as per Table 1. An air space must remain to compensate for oil expansion (See Fig. 10 and Fig. 11). Set unit on side and fill.



**IMPORANT! - Do not overfill oil. Overfilling of seal chamber with oil can create excessive and dangerous hydraulic pressure which can destroy the pump and create a hazard. Overfilling oil voids warranty.**

**E-1.3) Pressure Test:**

Seal Chamber - Before checking the pump for leaks around the shaft seal, the oil level should be full. Remove pipe plug. Apply pipe sealant to pressure gauge assembly and tighten into pipe plug hole. Pressurize motor housing to 10 P.S.I. Use a soap solution around the sealed area and inspect joints for "air bubbles". If, after five minutes, the pressure is still holding constant, and no "bubbles" are observed, slowly bleed the pressure and remove the gauge assembly. Replace the pipe plug using a sealant. If the pressure does not hold, then the leak must be located.



**CAUTION! - Pressure builds up extremely fast, increase pressure by "tapping" air nozzle. Too much pressure will damage seal. Do Not exceed 10 P.S.I. in seal chamber.**

TABLE 1 - COOLING OIL - Dielectric	
SUPPLIER	GRADE
BP	Enerpar SE100
Conoco	Pale Paraffin 22
Mobil	D.T.E. Oil Light
G & G Oil	Circulating 22
Imperial Oil	Voltesso-35
Shell Canada	Transformer-10
Texaco	Diala-Oil-AX
Woco	Premium 100

## E-2) Impeller and Volute Service:

### E-2.1) Disassembly and Inspection:

To clean out the volute (11), or clean out or replace impeller (6), disconnect power, remove cap screws (2) then vertically lift motor assembly from the pump body (11). Clean out the volute, if necessary, clean and examine impeller (6) for pitting or wear, replace if required. To remove Impeller (6), remove cap screw (8) and washer (8A). The impeller is keyed onto the shaft with a square key (7) and to remove, pull impeller straight off the shaft using a wheel puller if required. Inspect o-ring (9) and replace if cut or damaged. Before reinstallation, check the motor shaft and impeller bore for damage.

### E-2.2) Reassembly:

To install impeller (6), apply a thin film of oil to motor shaft and slide impeller straight onto shaft, keeping keyways lined up. Drive key (7) into keyway. Thread cap screw (8) and washer (8A) into shaft and torque to 45 ft. lbs. Rotate impeller to check for binding. Place o-ring (9) on seal plate pilot diameter lining up holes and install impeller and motor assembly onto volute (11). Loctite cap screws (2), insert into volute and motor assembly and torque to 35 ft. lbs. Check for free rotation of motor and impeller.

## E-3) Outer Shaft Seal Service:



**CAUTION ! - Handle seal parts with extreme care. DO NOT scratch or mar lapped surfaces.**

### E-3.1) Disassembly and Inspection:

To expose outer shaft seal (4) for examination, remove Impeller and Volute per Section E-2.1. Set motor assembly (1) in the inverted position to prevent loss of oil. Remove snap ring from motor shaft, then retaining ring (5), spring (4C) and rotating member (4B) from shaft. See Figure 6. Examine all seal parts and especially contact faces. Inspect seal for signs of wear such as uneven wear pattern on stationary members, chips and scratches on either seal face. **DO NOT** interchange seal components, replace the entire shaft seal (4). If replacing seal, remove stationary (4A) from mounting plate by prying out with flat screw driver.

### E-3.2) Reassembly:

Lightly oil (**DO NOT use grease**) outer surface of stationary member (4A). Press stationary member (4A) firmly into mounting plate using a seal pusher but the seal pusher is to come in contact with seal face (See Fig. 7).

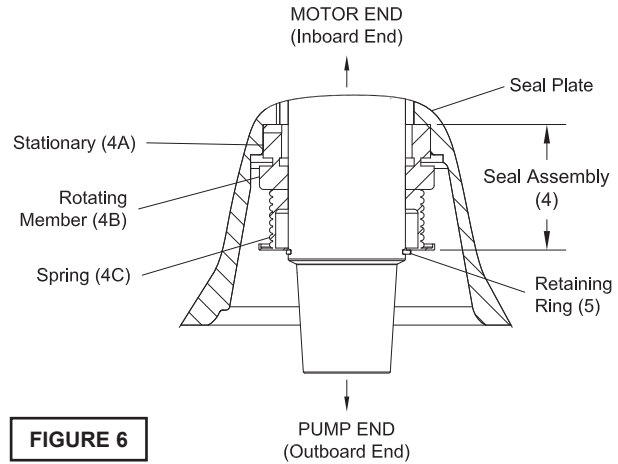

FIGURE 6

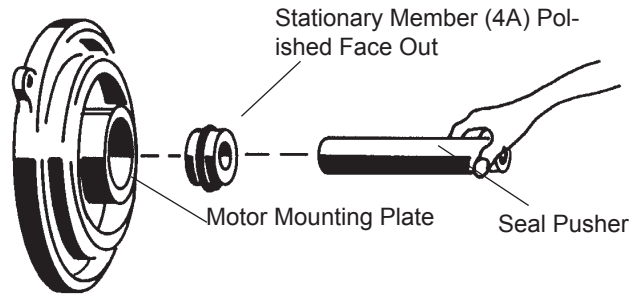

FIGURE 7

Make sure the stationary member is in straight and that the rubber ring is not out of it's groove. Lightly oil (**DO NOT use grease**) shaft and inner surface of bellows on rotating member (4B) see Figure 8. With lapped surface of rotating member (4B) facing inward toward stationary member (4A), slide rotating member (4B) onto shaft using a seal pusher, until lapped faces of (4A) and (4B) are together. (See Fig. 8).

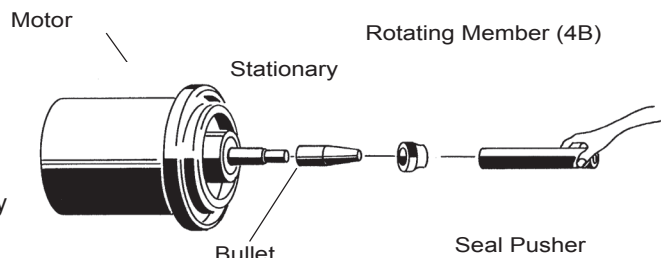

FIGURE 8



**IMPORTANT ! - It is extremely important to keep seal faces clean during assembly. dirt particles lodged between these faces will cause the seal to leak.**

Place spring (4C) over shaft and in place on rotating member (4B), making sure it is seated on retainer and not cocked or resting on bellows tail. Slide retaining ring (5) over shaft and let rest on spring (4C). Replace snap ring onto motor shaft. Inspect gasket (9) and replace if cut or damaged. Assemble impeller and volute as outlined in paragraph E-2.2.

## SECTION: F REPLACEMENT PARTS

### F-1 ORDERING REPLACEMENT PARTS:

When ordering replacement parts, ALWAYS furnish the following information:

1. Pump serial number and date code. (Paragraph F-4)
2. Pump model number. (Paragraph F-3)
3. Pump part number. (Paragraph F-2)
4. Part description.
5. Item part number.
6. Quantity required.
7. Shipping instructions.
8. Billing Instructions.

<input type="radio"/> <b>CRANE</b> PUMPS & SYSTEMS Piqua, Ohio		<b>BARNES</b> <sup>™</sup>		<input type="radio"/>
Power		Ph.	RPM	Volts
Hz.	FLA.	SFA	SF	
Ambient 40°C	Duty CONT.	Code	Weight	Part No.
Model No.	Serial No.		Imp. Dia.	

- CONNECT THERMAL CONTACTS  
 - SUBMERSIBLE TO 66 FEET  
 - SUBMERSIBLE SEWAGE PUMP

**WARNING**

1. TO REDUCE RISK OF ELECTRICAL SHOCK: A.) SEE INSTRUCTION MANUAL FOR PROPER INSTALLATION. B.) PUMP MUST BE PROPERLY GROUNDED IN ACCORDANCE WITH THE NATIONAL ELECTRICAL CODE AND ALL LOCAL CODES. C.) DISCONNECT THE PUMP FROM THE POWER SOURCE BEFORE HANDLING OR SERVICING. D.) INSTALLATION AND SERVICE SHALL BE CONDUCTED BY A QUALIFIED PERSON.
2. USE WITH APPROVED MOTOR CONTROL THAT MATCHES MOTOR INPUT IN FULL LOAD AMPERES WITH OVERLOAD ELEMENT(S) SELECTED OR ADJUSTED IN ACCORDANCE WITH CONTROL INSTRUCTIONS. (UTILISER UN DÉMARREUR APPROUVÉ CONVENANT AU COURANT À PLEINECHARGE DU MOTEUR ET DONT LES ÉLÉMENTS THERMIQUES SONT RÉGLÉS OU CHOISIS CONFORMÉMENT AUX INSTRUCTION QUI L'ACCOMPAGNENT).
3. KEEP CLEAR OF SUCTION AND DISCHARGE OPENING AT ALL TIMES WHERE POWER IS CONNECTED.
4. MOTOR HOUSING WILL CONTAIN HOT OIL UNDER PRESSURE, ALLOW MOTOR TO COOL BEFORE OPENING.
5. THIS PUMP IS NOT INTENDED FOR USE IN SWIMMING POOLS, DECORATIVE FOUNTAINS OR INSTALLATIONS IN WHICH HUMAN CONTACT WITH THE PUMPED MEDIA IS A COMMON OCCURENCE.
  6. DO NOT PUMP FLAMMABLE LIQUIDS.
  7. DO NOT REMOVE CORD AND STRAIN RELIEF.
  8. DO NOT CONNECT CONDUIT TO PUMP.

127264





CSA 108  
 UL 778  
 US LR16567

### F-2 PART NUMBER:

This number is used for ordering and obtaining information.

### F-3 MODEL NUMBER:

This designation consists of numbers and letters which represent the discharge size, series, horsepower, motor phase and voltage, speed and pump design. This number is used for ordering and obtaining information.

### F-4 SERIAL NUMBER:

The serial number block will consist of a six digit number, which is specific to each pump and may be preceded by an alpha character, which indicates the plant location. This number will also be suffixed with a four digit number, which indicates the date the unit was built (Date Code).

**EXAMPLE: A012345 0490.**

Reference the six digit portion (Serial Number) of this number when referring to the product.

## TROUBLE SHOOTING

**CAUTION !** Always disconnect the pump from the electrical power source before handling.  
 If the system fails to operate properly, carefully read instructions and perform maintenance recommendations.  
 If operating problems persist, the following chart may be of assistance in identifying and correcting them:  
**MATCH "CAUSE" NUMBER WITH CORRELATING "CORRECTION" NUMBER.**

**NOTE:** Not all problems and corrections will apply to each pump model.

PROBLEM	CAUSE	CORRECTION
Pump will not run	<ol style="list-style-type: none"> <li>1. Poor electrical connection, blown fuse, tripped breaker or other interruption of power, improper power supply.</li> <li>2. Motor or switch inoperative (to isolate cause, go to manual operation of pump).</li> <li>2a. Float movement restricted.</li> <li>2b. Switch will not activate pump or is defective.</li> <li>2c. Defective motor</li> <li>3. Insufficient liquid level.</li> </ol>	<ol style="list-style-type: none"> <li>1. Check all electrical connections for security. Have electrician measure current in motor leads, if current is within <math>\pm 20\%</math> of locked rotor Amps, impeller is probably locked. If current is 0, overload may be tripped. Remove power, allow pump to cool, then recheck current.</li> <li>2a. Reposition pump or clean basin as required to provide adequate clearance for float.</li> </ol>
Pump will not turn off	<ol style="list-style-type: none"> <li>2a. Float movement restricted.</li> <li>2b. Switch will not activate pump or is defective.</li> <li>4. Excessive inflow or pump not properly sized for application.</li> <li>9. Pump may be airlocked</li> <li>14. H-O-A switch on panel is in "HAND" position</li> </ol>	<ol style="list-style-type: none"> <li>2b. Disconnect level control. Set ohmmeter for a low range, such as 100 ohms full scale and connect to level control leads. Actuate level control manually and check to see that ohmmeter shows zero ohms for closed switch and full scale for open switch. (Float Switch).</li> <li>2c. Check winding insulation (Megger Test) and winding resistance. If check is outside of range, dry and recheck. If still defective, replace per service instructions.</li> </ol>
Pump hums but does not run	<ol style="list-style-type: none"> <li>1. Incorrect voltage</li> <li>8. Impeller jammed or loose on shaft, worn or damaged, impeller cavity or inlet plugged.</li> </ol>	<ol style="list-style-type: none"> <li>2c. Check winding insulation (Megger Test) and winding resistance. If check is outside of range, dry and recheck. If still defective, replace per service instructions.</li> </ol>
Pump delivers insufficient capacity	<ol style="list-style-type: none"> <li>1. Incorrect voltage.</li> <li>4. Excessive inflow or pump not properly sized for application.</li> <li>5. Discharge restricted.</li> <li>6. Check valve stuck closed or installed backwards.</li> <li>7. Shut-off valve closed.</li> <li>8. Impeller jammed or loose on shaft, worn or damaged, impeller cavity or inlet plugged.</li> <li>9. Pump may be airlocked.</li> <li>10. Pump running backwards</li> </ol>	<ol style="list-style-type: none"> <li>3. Make sure liquid level is at least equal to suggested turn-on point.</li> <li>4. Recheck all sizing calculations to determine proper pump size.</li> <li>5. Check discharge line for restrictions, including ice if line passes through or into cold areas.</li> <li>6. Remove and examine check valve for proper installation and freedom of operation.</li> <li>7. Open valve.</li> </ol>
Pump cycles too frequently or runs periodically when fixtures are not in use	<ol style="list-style-type: none"> <li>6. Check valve stuck closed or installed backwards.</li> <li>11. Fixtures are leaking.</li> <li>15. Ground water entering basin.</li> </ol>	<ol style="list-style-type: none"> <li>8. Check impeller for freedom of operation, security and condition. Clean impeller and inlet of any obstruction.</li> <li>9. Loosen union slightly to allow trapped air to escape. Verify that turn-off level of switch is set so that the suction is always flooded. Clean vent hole.</li> </ol>
Pump shuts off and turns on independent of switch, (trips thermal overload protector). <b>CAUTION!</b> Pump may start unexpectedly. Disconnect power supply.	<ol style="list-style-type: none"> <li>1. Incorrect voltage.</li> <li>4. Excessive inflow or pump not properly sized for application.</li> <li>8. Impeller jammed, loose on shaft, worn or damaged, impeller cavity or inlet plugged.</li> <li>12. Excessive water temperature. (internal protection only)</li> </ol>	<ol style="list-style-type: none"> <li>10. Check rotation. If power supply is three phase, reverse any two of three power supply leads to ensure proper impeller rotation..</li> <li>11. Repair fixtures as required to eliminate leakage.</li> </ol>
Pump operates noisily or vibrates excessively	<ol style="list-style-type: none"> <li>2c. Worn bearings, motor shaft bent.</li> <li>5. Debris in impeller cavity or broken impeller</li> <li>10. Pump running backwards</li> <li>13. Piping attachments to building structure too rigid or too loose.</li> </ol>	<ol style="list-style-type: none"> <li>12. Check pump temperature limits &amp; fluid temperature.</li> <li>13. Replace portion of discharge pipe with flexible connector.</li> <li>14. Turn to automatic position.</li> <li>15. Check for leaks around basin inlet and outlets.</li> </ol>

MODEL NUMBER	DIM. 'A' INCHES (MM)
3SHVC 3XSHVC	3.00 (76.2)
3SHVR 3XSHVR	
3SHVRA 3XSHVRA	3.50 (88.9)
3SHMPA 3XSHMPA	
4SHMS 4XSHMS	3.75 (95.3)
4SHDF 4XSHDF	
4SHVA 4XSHVA	4.00 (101.6)
4SHVB 4XSHVB	
4SHVBA 4XSHVBA	4.25 (108)
4SHMC 4XSHMC	
4SHDG 4XSHDG	4.75 (120.7)
4SHMD 4XSHMD	
6SHVL 6XSHVL	5.25 (133.4)
6SHDO 6XSHDO	5.50 (139.7)
4SHMB 4XSHMB	6.00 (152.4)
4SHME 4XSHME	
4SHMEA 4XSHMEA	
4SHDI 4XSHDI	
6SHMN 6XSHMN	6.50 (165.1)
6SHMH 6XSHMH	
6SHMJ 6XSHMJ	
6SHDK 6XSHDK	
6SHVT 6XSHVT	7.50 (190.5)
8SHDU 8XSHDU	8.75 (222.3)
8SHTM 8XSHTM	9.25 (235)
8SHVV 8XSHVV	11.50 (292.1)
10SHDW 10XSHDW	12.00 (304.8)
10SHDX 10XSHDX	

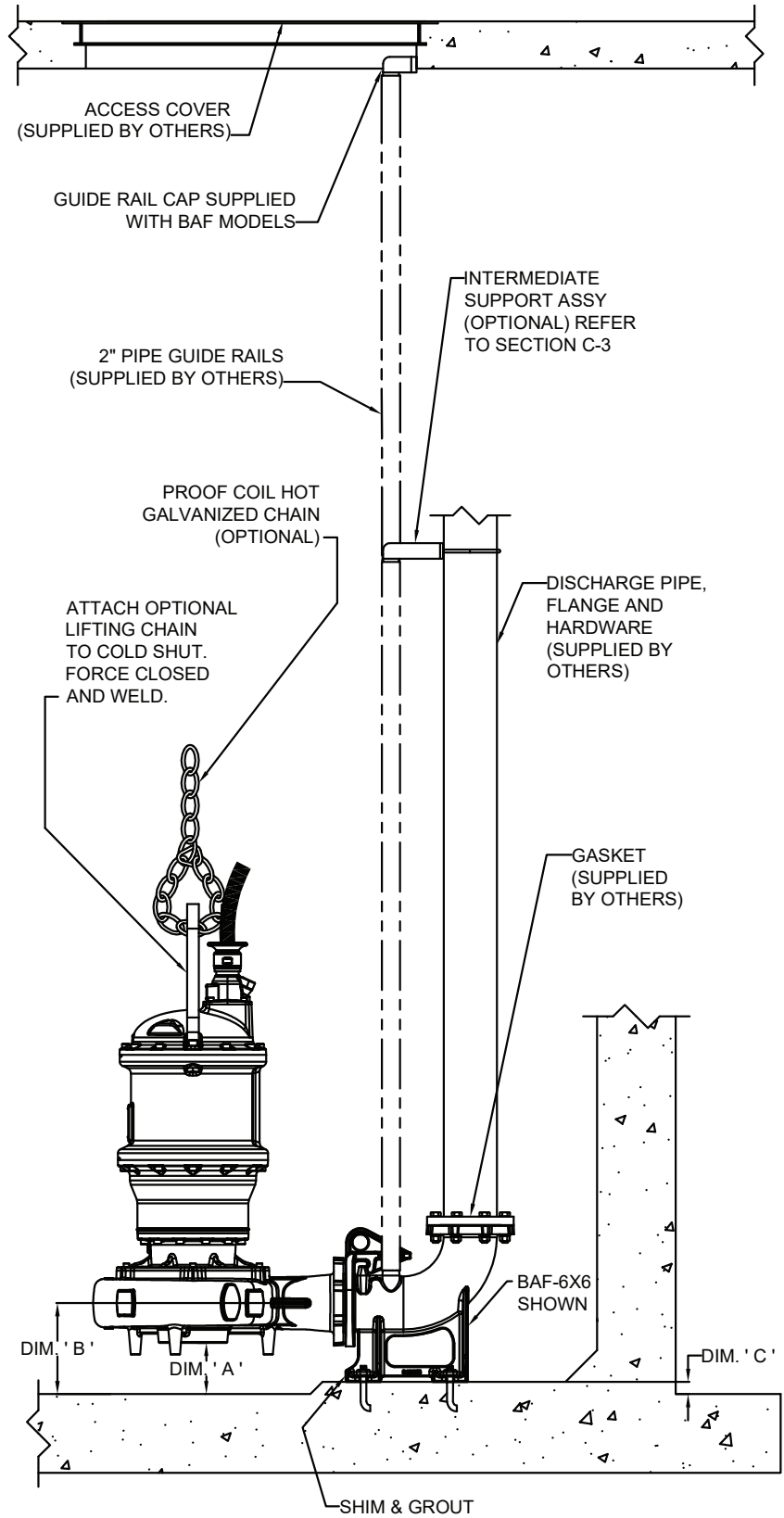

**FIGURE 9**

**NOTE:** DIMENSION 'A' IS RECOMMENDED CLEARANCE BASED ON HYDRAULIC INSTITUTE STANDARD 9.8.2.3.2.2.

# SH Pump Series - Cross Sections

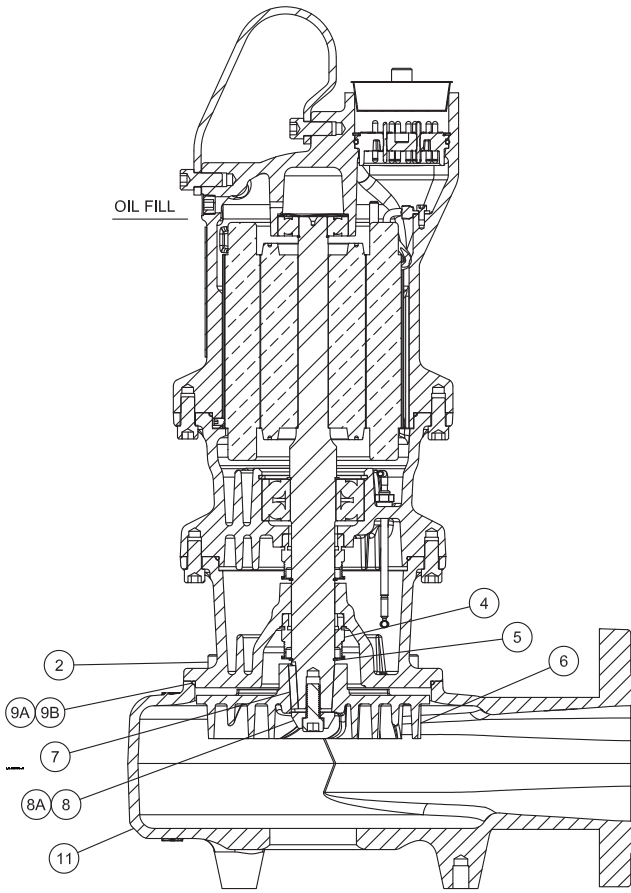

**SH Vortex**

**FIGURE 10**

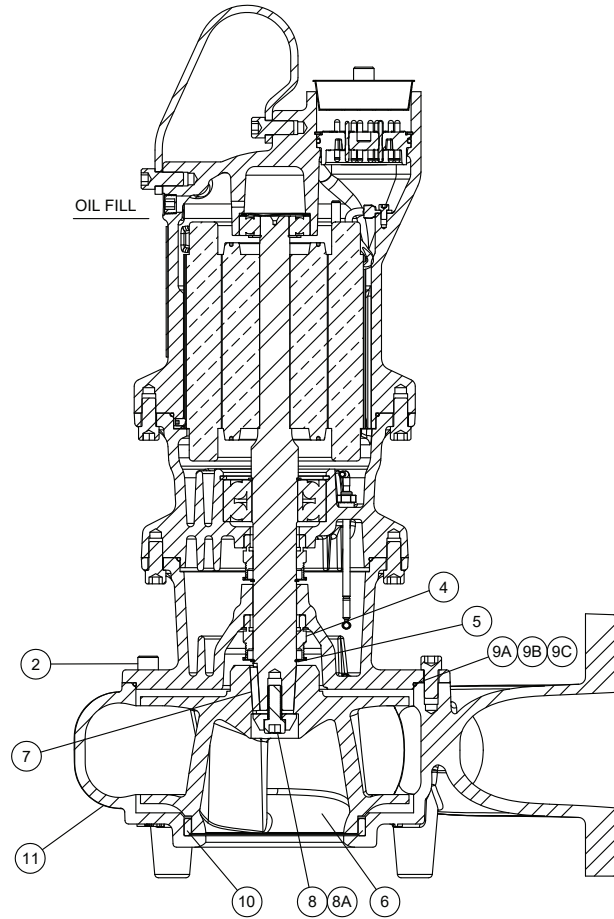

**SH Enclosed**

**FIGURE 11**



# SH Pump Series - Exploded Views

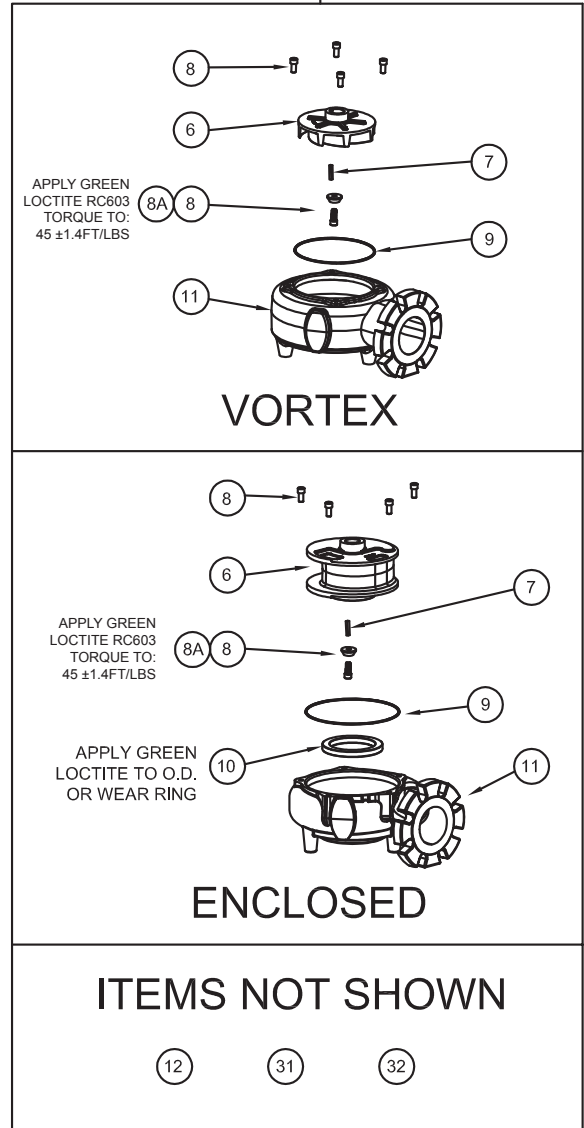
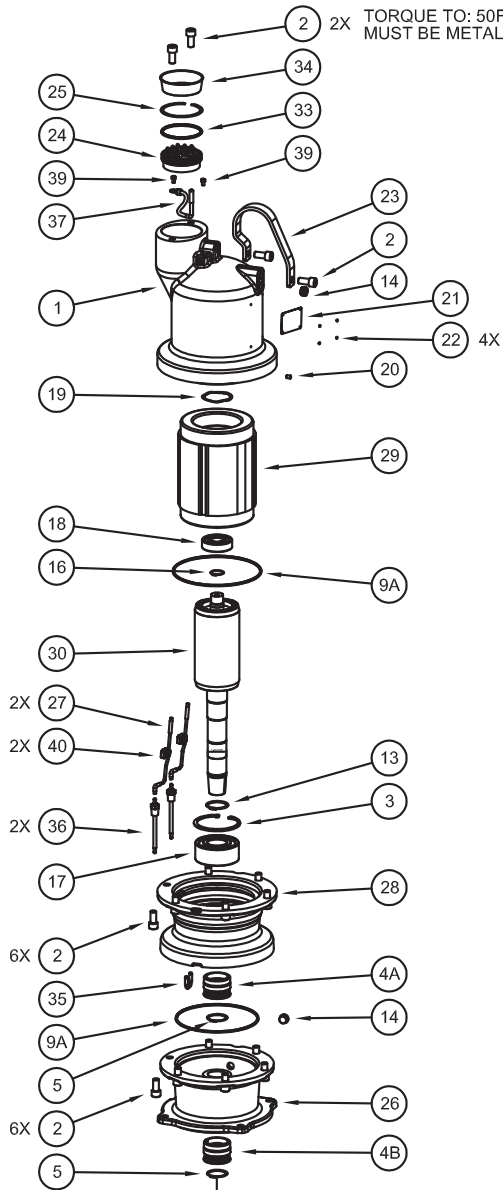

FIGURE 12

## SH 18 Frame - PARTS LIST

<b>Rotor Kit</b> .....	See Table on Page 31	(◇) 13, 16, 30
<b>Stator Kit</b> .....	See Table on Page 31	(≈) 1, 14, 20, 29, 31, 32, 34, 38
<b>Seal Kit</b> .....	See Table on Page 30	(+) 4A, 4B, 5, 7, 9A, 9B, 9C, 33
<b>Bearing Kit</b> .....	p/n 138579	(●) 3, 17, 18, 19
<b>Hardware Kit</b> .....	p/n 138615	(◆) 2, 8, 8A, 20, 39
<b>Volute Kit</b> .....	See Table on Page 26	(■) 10, 11, 31, 32
<b>Seal Plate Kit</b> .....	See Table on Page 26	(‡) 14, 26, 31, 32
<b>Bearing Bracket Kit</b> .....	p/n 138610	(▣) 28, 31, 32
<b>Terminal Block Kit</b> .....	p/n 138593	(§) 24, 25, 33, 37, 39
<b>Moisture Sensor Kit</b> .....	p/n 138613	(-) 27, 35, 36, 40
<b>Impeller Attachment Kit</b> .....	p/n 138614	(○) 8, 8A
<b>Leg Kit</b> .....	See Table on Page 29	

ITEM	QTY	PART NO.	DESCRIPTION	MATERIAL
1	1	133023	≈ Housing, Motor	Class 30 CI
2		127223	◆ Screw, SHCS, M12 x 1.75 x 25	18-8 SS
3	1	0033607	● Ring, Snap, Tru-Arc	Steel
4A	1	133029	+ Seal, Mechanical Type 21, 1.5", C/CE/B	
4B	1	133029SD	+ Seal, Mechanical Type 21, 1.5", SC/SC/B	
5	2	133048	+ Ring, Retaining, EXT, 5100	420 SS
6	1	See Table	Single Sale Impeller	Ductile Iron
7	1	Q21-20-J8	+ Key, ¼ x ¼ x 1½"	303 SS
8	1	136284	◆ ○ Screw, SHCS, M12 x 1.75 x 30	18-8 SS
8A	1	136233	◆ ○ Washer, Imp, .50 x 1.50	18-8 SS
9		See Table	+ O-Ring	
9A	2	125857-163	+ O-Ring, M3 x 163, 70 Duro	Buna-N
10		See Table	■ Wear Ring (Volute)	Bronze
11		See Table	■ Volute	Cast Iron
12	48oz	029034	Seal Chamber Oil Fill	Oil
13	1	121305	◇ Ring, Snap, Tru-Arc	Steel
14	2	014270-SS	≈ ‡ Plug, Pipe, 0.375-18NPT,	SS
16	1	0038377	◇ Ring, Snap, Tru-Arc	Steel
17	1	0016456	● Bearing, Ball, 3308	
18	1	0038378	● Bearing, Ball, 6305	
19	1	133041	● Washer, Springer, Wavy, 72mm	Steel
20	1	0058556	≈ ◆ Screw, Set	SS
21	1	127264	No Resale Nameplate, Main	300 Stainless Steel
22	4	001628	No Resale Rivet, Nameplate	Stainless Steel
23	1	133032	Single Sale Handle, Lifting	304 Stainless Steel
24	1	133031	§ Block, Term, 17 pin, 180, Quick	Valox/BR
25	1	133049	§ Ring, Retaining	Steel
26	1	See Chart	‡ Plate, Seal	Class 30 CI
27	2	127234C	- Wire, Jumper, Orange, 18", Bar/Bar	
28	1	133027	▣ Bracket, Bearing	Class 30 CI
29	1	133021	≈ Stator	
30	1	133022	◇ Assy, Rotor/Shaft	
31	5	125502	≈ ■‡▣ Paint, Epoxy, Part "A", Blue	
32	5	125503	≈ ■‡▣ Paint, Epoxy, Part "B", VF-525	
33	1	2-31003-234	+ § O-Ring, 2-234, Buna-N, 70 Duro	Buna-N
34	1	127270	≈ Plug, Cap, 3.37", Tapered	PE
35	1	127267	- Resistor, Moisture, Sensor	
36	2	125856	- Sensor, Moisture, ¼-18NPT, AMP	PP / SS
37	1	127249	§ Wire, Jumper, Green, 6", Bar/O-Ring, 8G	
38	1	039462	≈ Tie, Cable	
39	2	125855	◆ § Screw, SHCS, M5 x 0.8 x 8	Stainless Steel
40	2	134013	- Connector, Wire, Clip	

### SH Pump Series Power Cable Chart

Part No.	Length (feet)	Volt	Max. Amps	CORD SIZE	CORD O.D. +/- .02in (.5mm)
125496XC	30	208-240	31.7	12/4 - 18/4	0.86in (22.0mm)
125496XF	50	208-240	31.7	12/4 - 18/4	0.86in (22.0mm)
125496XJ	75	208-240	31.7	12/4 - 18/4	0.86in (22.0mm)
125496XL	100	208-240	31.7	12/4 - 18/4	0.86in (22.0mm)
125497XC	30	400-600	31.7	12/4 - 18/4	0.86in (22.0mm)
125497XF	50	400-600	31.7	12/4 - 18/4	0.86in (22.0mm)
125497XJ	75	400-600	31.7	12/4 - 18/4	0.86in (22.0mm)
125497XL	100	400-600	31.7	12/4 - 18/4	0.86in (22.0mm)
125498XC	30	208-240	59.0	8/4 - 18/4	1.12in (28.4mm)
125498XF	50	208-240	59.0	8/4 - 18/4	1.12in (28.4mm)
125498XJ	75	208-240	59.0	8/4 - 18/4	1.12in (28.4mm)
125498XL	100	208-240	59.0	8/4 - 18/4	1.12in (28.4mm)
125499XC	30	400-600	59.0	8/4 - 18/4	1.12in (28.4mm)
125499XF	50	400-600	59.0	8/4 - 18/4	1.12in (28.4mm)
125499XJ	75	400-600	59.0	8/4 - 18/4	1.12in (28.4mm)
125499XL	100	400-600	59.0	8/4 - 18/4	1.12in (28.4mm)

### Volute Pilot Diameter

Model	Volute Size	Volute P/N	Volute Kit P/N	Seal Plate P/N	Seal Plate Kit P/N	Volute Wear Ring P/N	O-Ring P/N
3SHVC	208mm	143800	144036	133025P	138584	N/A	125857-200
3SHVR	180mm	133035	138609	133026P	138583	N/A	125857-163
3SHVRA	208mm	137352	139231	133025P	138584	N/A	125857-200
3SHMPA	208mm	137224	139232	133025P	138584	129998	125857-200
4SHVA	208mm	125453	138597	133025P	138584	N/A	125857-200
4SHVB	208mm	125453	138597	133025P	138584	N/A	125857-200
4SHVBA	240mm	137354	139233	133024P	138585	N/A	125857-235
4SHMS	208mm	133033	138601	133025P	138584	133045	125857-200
4SHMC	240mm	129994	138598	133024P	138585	129996	125857-235
4SHMD	305mm	Not Available in 18 Frame					
4SHMB	370mm						
4SHME	370mm						
4SHMEA	370mm						
4SHDF	208mm	133033	138601	133025P	138584	133045	125857-200
4SHDG	240mm	129994	138602	133024P	138585	129997	125857-235
4SHDI	370mm	Not Available in 18 Frame					
6SHVL	370mm						
6SHVT	465mm						
6SHMN	370mm						
6SHMH	370mm						
6SHMJ	370mm						
6SHDO	305mm						
6SHDK	370mm						
8SHVV	465mm						
8SHDU	305mm						
8SHTM	370mm						
10SHDW	370mm						
10SHDX	465mm						

<b>"A" Impeller– Vortex</b>		
<b>Trim Dia. mm (in)</b>	<b>Ductile Iron Part No.</b>	<b>Nihard Part No.</b>
205mm (8.07in)	125454B	143272B
200mm (7.87in)	125454BTA	143272BTA
195mm (7.68in)	125454BTB	143272BTB
205mm (8.07in)	125454	143272
200mm (7.87in)	125454TA	143272TA
195mm (7.68in)	125454TB	143272TB
190mm (7.48in)	125454TC	143272TC
185mm (7.28in)	125454TD	143272TD
180mm (7.09in)	125454TE	143272TE
175mm (6.89in)	125454TF	143272TF
170mm (6.69in)	125454TG	143272TG
165mm (6.50in)	125454TH	143272TH
160mm (6.30in)	125454TJ	143272TJ
155mm (6.10in)	125454TK	143272TK
150mm (5.91in)	125454TL	143272TL
145mm (5.71in)	125454TM	143272TM
140mm (5.51in)	125454TN	143272TN
135mm (5.31in)	125454TP	143272TP
130mm (5.12in)	125454TR	143272TR
125mm (4.92in)	125454TS	143272TS

<b>"B" Impeller– Vortex</b>		
<b>Trim Dia. mm (in)</b>	<b>Ductile Iron Part No.</b>	<b>Nihard Part No.</b>
185mm (7.28in)	125456	143273
180mm (7.09in)	125456TA	143273TA
175mm (6.89in)	125456TB	143273TB
170mm (6.69in)	125456TC	143273TC
165mm (6.50in)	125456TD	143273TD
160mm (6.30in)	125456TE	143273TE
155mm (6.10in)	125456TF	143273TF
150mm (5.91in)	125456TG	143273TG
145mm (5.71in)	125456TH	143273TH
140mm (5.51in)	125456TJ	143273TJ
135mm (5.31in)	125456TK	143273TK
130mm (5.12in)	125456TL	143273TL
125mm (4.92in)	125456TM	143273TM
120mm (4.72in)	125456TN	143273TN
115mm (4.53in)	125456TP	143273TP
110mm (4.33in)	125456TR	143273TR
105mm (4.13in)	125456TS	143273TS
100mm (3.94in)	125456TT	143273TT
95mm (3.74in)	125456TU	143273TU

<b>"C" Impeller– Monovane</b>		
<b>Trim Dia. mm (in)</b>	<b>Ductile Iron Part No.</b>	<b>Nihard Part No.</b>
235mm (9.25in)	127263	143276
230mm (9.06in)	127263TA	143276TA
225mm (8.86in)	127263TB	143276TB
220mm (8.66in)	127263TC	143276TC
215mm (8.46in)	127263TD	143276TD
210mm (8.27in)	127263TE	143276TE
205mm (8.07in)	127263TF	143276TF
200mm (7.87in)	127263TG	143276TG
195mm (7.68in)	127263TH	143276TH
190mm (7.48in)	127263TJ	143276TJ
185mm (7.28in)	127263TK	143276TK

<b>"F" Impeller</b>		
<b>Trim Dia. mm (in)</b>	<b>Ductile Iron Part No.</b>	<b>Nihard Part No.</b>
190mm (7.48in)	133052	143277
185mm (7.28in)	133052TA	143277TA
180mm (7.09in)	133052TB	143277TB
175mm (6.89in)	133052TC	143277TC
170mm (6.69in)	133052TD	143277TD
165mm (6.50in)	133052TE	143277TE
160mm (6.30in)	133052TF	143277TF
155mm (6.10in)	133052TG	143277TG
150mm (5.91in)	133052TH	143277TH
145mm (5.71in)	133052TJ	143277TJ
140mm (5.51in)	133052TK	143277TK
135mm (5.31in)	133052TL	143277TL
130mm (5.12in)	133052TM	143277TM
125mm (4.92in)	133052TN	143277TN

<b>"G" Impeller</b>		
<b>Trim Dia. mm (in)</b>	<b>Ductile Iron Part No.</b>	<b>Nihard Part No.</b>
235mm (9.25in)	129991	143204
230mm (9.06in)	129991TA	143204TA
225mm (8.86in)	129991TB	143204TB
220mm (8.66in)	129991TC	143204TC
215mm (8.46in)	129991TD	143204TD
210mm (8.27in)	129991TE	143204TE
205mm (8.07in)	129991TF	143204TF
200mm (7.87in)	129991TG	143204TG
195mm (7.68in)	129991TH	143204TH
190mm (7.48in)	129991TJ	143204TJ
185mm (7.28in)	129991TK	143204TK
180mm (7.09in)	129991TL	143204TL
175mm (6.89in)	129991TM	143204TM
170mm (6.69in)	129991TN	143204TN
165mm (6.50in)	129991TP	143204TP

<b>"S" Impeller</b>		
<b>Trim Dia. mm (in)</b>	<b>Ductile Iron Part No.</b>	<b>Nihard Part No.</b>
200mm (7.87in)	133044	143287
195mm (7.68in)	133044TA	143287TA
190mm (7.48in)	133044TB	143287TB
185mm (7.28in)	133044TC	143287TC
180mm (7.09in)	133044TD	143287TD
175mm (6.89in)	133044TE	143287TE
170mm (6.69in)	133044TF	143287TF
165mm (6.50in)	133044TG	143287TG
160mm (6.30in)	133044TH	143287TH
155mm (6.10in)	133044TJ	143287TJ

<b>"R" Impeller</b>		
<b>Trim Dia. mm (in)</b>	<b>Ductile Iron Part No.</b>	<b>Nihard Part No.</b>
175mm (6.89in)	133050	143285
170mm (6.69in)	133050TA	143285TA
165mm (6.50in)	133050TB	143285TB
160mm (6.30in)	133050TC	143285TC
155mm (6.10in)	133050TD	143285TD
150mm (5.91in)	133050TE	143285TE
145mm (5.71in)	133050TF	143285TF
140mm (5.51in)	133050TG	143285TG
135mm (5.31in)	133050TH	143285TH
130mm (5.12in)	133050TJ	143285TJ
125mm (4.92in)	133050TK	143285TK
120mm (4.72in)	133050TL	143285TL
115mm (4.53in)	133050TM	143285TM
110mm (4.33in)	133050TN	143285TN
105mm (4.13in)	133050TP	143285TP
100mm (3.94in)	133050TR	143285TR
95mm (3.74in)	133050TS	143285TS
90mm (3.54in)	133050TT	143285TT

<b>"BA" Impeller</b>		
<b>Trim Dia. mm (in)</b>	<b>Ductile Iron Part No.</b>	<b>Nihard Part No.</b>
240mm (9.49in)	137353	143920
235mm (9.25in)	137353TA	143920TA
230mm (9.06in)	137353TB	143920TB
225mm (8.86in)	137353TC	143920TC
220mm (8.66in)	137353TD	143920TD
215mm (8.47in)	137353TE	143920TE
210mm (8.27in)	137353TF	143920TF
205mm (8.07in)	137353TG	143920TG
200mm (7.87in)	137353TH	143920TH
195mm (7.68in)	137353TJ	143920TJ
190mm (7.48in)	137353TK	143920TK
185mm (7.28in)	137353TL	143920TL
180mm (7.09in)	137353TM	143920TM
175mm (6.89in)	137353TN	143920TN
170mm (6.69in)	137353TP	143920TP
165mm (6.50in)	137353TQ	143920TQ
160mm (6.30in)	137353TR	143920TR
155mm (6.10in)	137353TS	143920TS
150mm (5.91in)	137353TT	143920TT
145mm (5.71in)	137353TU	143920TU

<b>"PA" Impeller</b>		
<b>Trim Dia. mm (in)</b>	<b>Ductile Iron Part No.</b>	<b>Nihard Part No.</b>
205mm (8.07in)	137223	143288
200mm (7.87in)	137223TA	143288TA
195mm (7.68in)	137223TB	143288TB
190mm (7.48in)	137223TC	143288TC
185mm (7.28in)	137223TD	143288TD
180mm (7.09in)	137223TE	143288TE
175mm (6.89in)	137223TF	143288TF
170mm (6.69in)	137223TG	143288TG

<b>"RA" Impeller</b>		
<b>Trim Dia. mm (in)</b>	<b>Ductile Iron Part No.</b>	<b>Nihard Part No.</b>
190mm (7.48in)	137351	143291
185mm (7.29in)	137351TA	143291TA
180mm (7.09in)	137351TB	143291TB
175mm (6.89in)	137351TC	143291TC
170mm (6.69in)	137351TD	143291TD
165mm (6.50in)	137351TE	143291TE
160mm (6.30in)	137351TF	143291TF
155mm (6.10in)	137351TG	143291TG
150mm (5.90in)	137351TH	143291TH
145mm (5.70in)	137351TJ	143291TJ
140mm (5.51in)	137351TK	143291TK
135mm (5.32in)	137351TL	143291TL
130mm (5.12in)	137351TM	143291TM
125mm (4.92in)	137351TN	143291TN
120mm (4.72in)	137351TP	143291TP

<b>"VC" Impeller</b>		
<b>Trim Dia. mm (in)</b>	<b>Ductile Iron Part No.</b>	<b>Nihard Part No.</b>
185mm (7.29in)	143801	143802
180mm (7.09in)	143801TA	143802TA
175mm (7.09in)	143801TB	143802TB
170mm (6.89in)	143801TC	143802TC
165mm (6.69in)	143801TD	143802TD
160mm (6.50in)	143801TE	143802TE
155mm (6.30in)	143801TF	143802TF
150mm (6.10in)	143801TG	143802TG
145mm (5.90in)	143801TH	143802TH
140mm (5.70in)	143801TJ	143802TJ
135mm (5.51in)	143801TK	143802TK
130mm (5.32in)	143801TL	143802TL
125mm (5.12in)	143801TM	143802TM
120mm (4.92in)	143801TN	143802TN

<b>Leg Kits</b>		
<b>Model</b>	<b>Leg Kit Part No.</b>	<b>Leg Kit Height Inches (mm)</b>
3SHVC	125506	3.15 (80)
3SHVR	125506	3.15 (80)
3SHVRA	125506	3.15 (80)
3SHMPA	125506	3.15 (80)
4SHMS	125506	3.15 (80)
4SHDF	125506	3.15 (80)
4SHVA	125506	3.15 (80)
4SHVB	125506	3.15 (80)
4SHVBA	125506	3.15 (80)
4SHMC	125506	3.15 (80)
4SHDG	125506	3.15 (80)
4SHMD	125506B	6.50 (165)
6SHVL	125506	3.15 (80)
6SHDO	125506B	6.50 (165)
4SHMB	125506B	6.50 (165)
4SHME	125506B	6.50 (165)
4SHMEA	125506B	6.50 (165)
4SHDI	125506B	6.50 (165)
6SHMN	125506B	6.50 (165)
6SHMH	125506B	6.50 (165)
6SHMJ	125506B	6.50 (165)
6SHDK	125506B	6.50 (165)
6SHVT	125506B	6.50 (165)
8SHDU	125506B	6.50 (165)
8SHTM	125506C	10.75 (273)
8SHVV	125506C	10.75 (273)
10SHDW	125506C	10.75 (273)
10SHDX	125506C	10.75 (273)

<b>Leg Kit includes:</b>
<ul style="list-style-type: none"> <li>• 3 Legs (painted)</li> <li>• attachment hardware</li> </ul>

Seal Kits				
Seal Kit Part No.	I.B. Seal Part No.	I.B. Seal Material	O.B. Seal Part No.	O.B Seal Material
138618	133029	Carbon / Ceramic	133029	Carbon / Ceramic
138580 (STD)	133029	Carbon / Ceramic	133029SD	Silicon Carbide / Silicon Carbide
138619	133029	Carbon / Ceramic	133029SB	Tungsten Carbide / Tungsten Carbide
138620	133029SD	Silicon Carbide / Silicon Carbide	133029SD	Silicon Carbide / Silicon Carbide
138621	133029SD	Silicon Carbide / Silicon Carbide	133029SB	Tungsten Carbide / Tungsten Carbide
138622	133029SB	Tungsten Carbide / Tungsten Carbide	133029SB	Tungsten Carbide / Tungsten Carbide

**Seal Kit includes:**

- Lower Volute O-Ring (option 1)
- Lower Volute O-Ring (option 2)
- Lower Volute O-Ring (option 3)
- Seal Plate upper O-ring and Stator Lower O-ring
- Terminal Block O-ring
- External Retaining Ring
- Key
- Upper Mechanical Seal
- Lower Mechanical Seal

**NOTE:** Kit contains hardware your pump may not require.

**Bearing Kit includes:**

- Bearing Retaining Snap Ring
- Large Ball Bearing
- Small Ball Bearing
- Wavy Spring Washer

**Bearing Bracket Kit includes:**

- Bearing Bracket (painted)

**Volute Kit includes:**

- Wear Ring (pressed)
- Volute (painted)

**Seal Plate Kit includes:**

- Large Pipe Plug
- Seal Plate (painted)

**Terminal Block Kit includes:**

- Terminal Block
- Internal Retaining Ring
- Terminal Block O-Ring
- Green Wire Jumper
- Terminal Block Screw

**Moisture Sensor Kit includes:**

- 18" Orange Wire Jumper
- 24" Blue Wire Jumper
- Moisture Sensor Resistor
- Moisture Sensor
- 36" Orange Wire Jumper
- Wire Connector Clip
- 24" Orange Wire Jumper

**Hardware Kit includes:**

- Socket Head Cap Screws (for Housing)
- Impeller Bolt and Washer Set
- Socket Set Screw
- Socket Head Cap Screw (for Sensor)

**Impeller Attachment Kit includes:**

- Impeller Washer
- Impeller Bolt

**NOTE:**

Kits contain hardware your pump may not require.

3450 RPM		
Model No.	Rotor Kit Part No.	Stator / Motor Housing Kit Part No.
– SH – – 5072	133927	133928
– SH – – 50N2	133929	133930
– SH – – 5052	133931	133932
– SH – – 75N2	133933	133934
– SH – – 7552	133935	133936
– SH – – 100N2	138722	133938
– SH – – 10052	133939	133940
– SH – – 3052	138641	138642

1750 RPM		
Model No.	Rotor Kit Part No.	Stator / Motor Housing Kit Part No.
– SH – – 2074	133941	133942
– SH – – 2054	133945	133946
– SH – – 3074	133947	133948
– SH – – 3054	133951	133952
– SH – – 5074	133953	138735
– SH – – 5054	133957	133958
– SH – – 7554	133961	133962
– SH – – 10054	138721	138730

1750 RPM	
Model No.	Motor Kit Part No.
– SH – – 20N4	145660
– SH – – 30N4	145663
– SH – – 50N4	145666
– SH – – 75N4	145668
– SH – – 100N4	145670

Example		
Model No.	Rotor Kit Part No.	Stator / Motor Housing Kit Part No.
4SHMS75N4	138729	138738

Rotor Kit includes:
<ul style="list-style-type: none"> <li>• Lower Shaft Snap Ring</li> <li>• Upper Shaft Snap Ring</li> <li>• Rotor</li> </ul>

Stator/Motor Housing Kit includes:
<ul style="list-style-type: none"> <li>• Motor Housing (painted)</li> <li>• Pipe Plug</li> <li>• Set Cap Screw</li> <li>• Stator</li> <li>• Self-clinching Tie Cable</li> <li>• Cap Plug</li> </ul>

Motor Kit includes:
<ul style="list-style-type: none"> <li>• Lower Shaft Snap Ring</li> <li>• Upper Shaft Snap Ring</li> <li>• Rotor</li> <li>• Motor Housing (Painted)</li> <li>• Pipe Plug</li> <li>• Set Cap Screw</li> <li>• Stator</li> <li>• Self-Clinching Tie Cable</li> <li>• Cap Plug</li> <li>• Terminal Block Kit</li> <li>• Moisture Sensor Kit</li> <li>• Bearing Bracket Kit</li> <li>• Bearing Kit</li> </ul>

\* Motor kits ship pre-assembled

Additional Components			
Component	Part No.	Single Sale	Kit
Impeller	See Table	Yes	N/A
Wear Ring	See Table	Yes	Volute Kit
Lifting Handle	133032	Yes	N/A
Pipe Plugs	014270-SS	Yes	Seal Plate Kit, Stator Kit
Wire Tie Cable	039462	Yes	Stator Kit
Nameplate		No Resale	
Nameplate/Model Plate Rivets	001628	No Resale	Rivet Kit (p/n 139398)
Driver Assembly	Purchase: Stator Kit, Rotor Kit, Seal Kit, Bearing Kit, Bearing Bracket Kit, Hardware Kit, Seal Plate Kit, Terminal Block Kit OR Motor Kit, Seal Plate Kit, Hardware Kit		
Overhaul Kit	Purchase Seal Kit and Hardware Kit		



Model	Rotor Kit	Stator Kit	Seal Kit	Bearing Kit	Volute Kit	Seal Plate Kit	Bearing Bracket Kit	Terminal Block Kit	Hardware Kit	Moisture Sensor Kit	Impeller Attachment Kit	Leg Kit
3SHVC3074	133947	133948	138618, 138580, 138619, 138620, 138621, 138622	138579	144036	138584	138610	138593	138615	138613	138614	125506
3SHVC30N4	See Motor Kit Table			138579	144036	138584	138610	138593	138615	138613	138614	125506
3SHVC3054	133951	133952		138579	144036	138584	138610	138593	138615	138613	138614	125506
3SHVC5074	133953	138735		138579	144036	138584	138610	138593	138615	138613	138614	125506
3SHVC50N4	See Motor Kit Table			138579	144036	138584	138610	138593	138615	138613	138614	125506
3SHVC5054	133957	133958		138579	144036	138584	138610	138593	138615	138613	138614	125506
3SHVR2054	133945	133946	138618, 138580, 138619, 138620, 138621, 138622	138579	138609	138583	138610	138593	138615	138613	138614	125506
3SHVR2074	133941	133942		138579	138609	138583	138610	138593	138615	138613	138614	125506
3SHVR20N4	See Motor Kit Table			138579	138609	138583	138610	138593	138615	138613	138614	125506
3SHVR3054	133951	133952		138579	138609	138583	138610	138593	138615	138613	138614	125506
3SHVR3074	133947	133948		138579	138609	138583	138610	138593	138615	138613	138614	125506
3SHVR30N4	See Motor Kit Table			138579	138609	138583	138610	138593	138615	138613	138614	125506
3SHVR5054	133957	133958		138579	138609	138583	138610	138593	138615	138613	138614	125506
3SHVR5074	133953	138735		138579	138609	138583	138610	138593	138615	138613	138614	125506
3SHVR50N4	See Motor Kit Table			138579	138609	138583	138610	138593	138615	138613	138614	125506
3SHVR5052	133931	133932		138579	138609	138583	138610	138593	138615	138613	138614	125506
3SHVR5072	133927	133928		138579	138609	138583	138610	138593	138615	138613	138614	125506
3SHVR50N2	133929	133930		138579	138609	138583	138610	138593	138615	138613	138614	125506
3SHVR7552	133935	133936	138579	138609	138583	138610	138593	138615	138613	138614	125506	
3SHVR75N2	133933	133934	138579	138609	138583	138610	138593	138615	138613	138614	125506	
3SHVR10052	133939	133940	138579	138609	138583	138610	138593	138615	138613	138614	125506	
3SHVR100N2	138722	133938	138579	138609	138583	138610	138593	138615	138613	138614	125506	
3SHVRA2054	133945	133946	138618, 138580, 138619, 138620, 138621, 138622	138579	138609	138583	138610	138593	138615	138613	138614	125506
3SHVRA2074	133941	133942		138579	138609	138583	138610	138593	138615	138613	138614	125506
3SHVRA20N4	See Motor Kit Table			138579	138609	138583	138610	138593	138615	138613	138614	125506
3SHVRA3054	133951	133952		138579	138609	138583	138610	138593	138615	138613	138614	125506
3SHVRA3074	133947	133948		138579	138609	138583	138610	138593	138615	138613	138614	125506
3SHVRA30N4	See Motor Kit Table			138579	138609	138583	138610	138593	138615	138613	138614	125506
3SHVRA5054	133957	133958		138579	138609	138583	138610	138593	138615	138613	138614	125506
3SHVRA5074	133953	138735		138579	138609	138583	138610	138593	138615	138613	138614	125506
3SHVRA50N4	See Motor Kit Table			138579	138609	138583	138610	138593	138615	138613	138614	125506
3SHVRA5052	133931	133932		138579	138609	138583	138610	138593	138615	138613	138614	125506
3SHVRA5072	133927	133928		138579	138609	138583	138610	138593	138615	138613	138614	125506
3SHVRA50N2	133929	133930		138579	138609	138583	138610	138593	138615	138613	138614	125506
3SHVRA7552	133935	133936	138579	138609	138583	138610	138593	138615	138613	138614	125506	
3SHVRA75N2	133933	133934	138579	138609	138583	138610	138593	138615	138613	138614	125506	
3SHVRA10052	133939	133940	138579	138609	138583	138610	138593	138615	138613	138614	125506	
3SHVRA100N2	138722	133938	138579	138609	138583	138610	138593	138615	138613	138614	125506	

Model	Rotor Kit	Stator Kit	Seal Kit	Bearing Kit	Volute Kit	Seal Plate Kit	Bearing Bracket Kit	Terminal Block Kit	Hardware Kit	Moisture Sensor Kit	Impeller Attachment Kit	Leg Kit	
3SHMPA3054	133951	133952	138618, 138580, 138619, 138620, 138621, 138622	138579	138608	138583	138610	138593	138615	138613	138614	125506	
3SHMPA3074	133947	133948		138579	138608	138583	138610	138593	138615	138613	138614	125506	
3SHMPA30N4	See Motor Kit Table			138579	138608	138583	138610	138593	138615	138613	138614	125506	
3SHMPA5054	133957	133958		138579	138608	138583	138610	138593	138615	138613	138614	125506	
3SHMPA5074	133953	138735		138579	138608	138583	138610	138593	138615	138613	138614	125506	
3SHMPA50N4	See Motor Kit Table			138579	138608	138583	138610	138593	138615	138613	138614	125506	
3SHMPA7554	133961	133962		138579	138608	138583	138610	138593	138615	138613	138614	125506	
3SHMPA75N4	See Motor Kit Table			138579	138608	138583	138610	138593	138615	138613	138614	125506	
4SHVA7552	133935	133936	138618, 138580, 138619, 138620, 138621, 138622	138579	138597	138584	138610	138593	138615	138613	138614	125506	
4SHVA75N2	133933	133934	138579	138597	138584	138610	138593	138593	138615	138613	138614	125506	
4SHVA10052	133939	133940	138579	138597	138584	138610	138593	138593	138615	138613	138614	125506	
4SHVA100N2	138722	133938	138579	138597	138584	138610	138593	138593	138615	138613	138614	125506	
4SHVB2054	133945	133946	138618, 138580, 138619, 138620, 138621, 138622	138579	138597	138584	138610	138593	138615	138613	138614	125506	
4SHVB2074	133941	133942		138579	138597	138584	138610	138593	138593	138615	138613	138614	125506
4SHVB20N4	See Motor Kit Table			138579	138597	138584	138610	138593	138593	138615	138613	138614	125506
4SHVB3054	133951	133952		138579	138597	138584	138610	138593	138593	138615	138613	138614	125506
4SHVB3074	133947	133948		138579	138597	138584	138610	138593	138593	138615	138613	138614	125506
4SHVB30N4	See Motor Kit Table			138579	138597	138584	138610	138593	138593	138615	138613	138614	125506
4SHVB5054	133957	133958		138579	138597	138584	138610	138593	138593	138615	138613	138614	125506
4SHVB5074	133953	138735		138579	138597	138584	138610	138593	138593	138615	138613	138614	125506
4SHVB50N4	See Motor Kit Table			138579	138597	138584	138610	138593	138593	138615	138613	138614	125506
4SHVB7554	133961	133962		138579	138597	138584	138610	138593	138593	138615	138613	138614	125506
4SHVB75N4	See Motor Kit Table			138579	138597	138584	138610	138593	138593	138615	138613	138614	125506
4SHVB10054	138721	138730		138579	138597	138584	138610	138593	138593	138615	138613	138614	125506
4SHVB100N4	See Motor Kit Table			138579	138597	138584	138610	138593	138593	138615	138613	138614	125506
4SHVB7552	133935	133936		138579	138597	138584	138610	138593	138593	138615	138613	138614	125506
4SHVB75N2	133933	133934		138579	138597	138584	138610	138593	138593	138615	138613	138614	125506
4SHVB10052	133939	133940		138579	138597	138584	138610	138593	138593	138615	138613	138614	125506
4SHVB100N2	138722	133938	138579	138597	138584	138610	138593	138593	138615	138613	138614	125506	

Model	Rotor Kit	Stator Kit	Seal Kit	Bearing Kit	Volute Kit	Seal Plate Kit	Bearing Bracket Kit	Terminal Block Kit	Hardware Kit	Moisture Sensor Kit	Impeller Attachment Kit	Leg Kit
4SHMS3054	133951	133952	138618, 138580, 138619, 138620, 138621, 138622	138579	138601	138584	138610	138593	138615	138613	138614	125506
4SHMS3074	133947	133948		138579	138601	138584	138610	138593	138615	138613	138614	125506
4SHMS30N4	See Motor Kit Table			138579	138601	138584	138610	138593	138615	138613	138614	125506
4SHMS5054	133957	133958		138579	138601	138584	138610	138593	138615	138613	138614	125506
4SHMS5074	133953	138735		138579	138601	138584	138610	138593	138615	138613	138614	125506
4SHMS50N4	See Motor Kit Table			138579	138601	138584	138610	138593	138615	138613	138614	125506
4SHMS7554	133961	133962		138579	138601	138584	138610	138593	138615	138613	138614	125506
4SHMS75N4	See Motor Kit Table			138579	138601	138584	138610	138593	138615	138613	138614	125506
4SHMC5054	133957	133958	138618, 138580, 138619, 138620, 138621, 138622	138579	138598	138585	138610	138593	138615	138613	138614	125506
4SHMC5074	133953	138735		138579	138598	138585	138610	138593	138615	138613	138614	125506
4SHMC50N4	See Motor Kit Table			138579	138598	138585	138610	138593	138615	138613	138614	125506
4SHMC7554	133961	133962		138579	138598	138585	138610	138593	138615	138613	138614	125506
4SHMC75N4	See Motor Kit Table			138579	138598	138585	138610	138593	138615	138613	138614	125506
4SHMC10054	138721	138730		138579	138598	138585	138610	138593	138615	138613	138614	125506
4SHMC100N4	See Motor Kit Table			138579	138598	138585	138610	138593	138615	138613	138614	125506
4SHDF3054	133951	133952		138618, 138580, 138619, 138620, 138621, 138622	138579	138601	138584	138610	138593	138615	138613	138614
4SHDF3074	133947	133948	138579		138601	138584	138610	138593	138615	138613	138614	125506
4SHDF30N4	See Motor Kit Table		138579		138601	138584	138610	138593	138615	138613	138614	125506
4SHDF5054	133957	133958	138579		138601	138584	138610	138593	138615	138613	138614	125506
4SHDF5074	133953	138735	138579		138601	138584	138610	138593	138615	138613	138614	125506
4SHDF50N4	See Motor Kit Table		138579		138601	138584	138610	138593	138615	138613	138614	125506
4SHDF7554	133961	133962	138579		138601	138584	138610	138593	138615	138613	138614	125506
4SHDF75N4	See Motor Kit Table		138579		138601	138584	138610	138593	138615	138613	138614	125506
4SHDG5054	133957	133958	138618, 138580, 138619, 138620, 138621, 138622	138579	138602	138585	138610	138593	138615	138613	138614	125506
4SHDG5074	133953	138735		138579	138602	138585	138610	138593	138615	138613	138614	125506
4SHDG50N4	See Motor Kit Table			138579	138602	138585	138610	138593	138615	138613	138614	125506
4SHDG7554	133961	133962		138579	138602	138585	138610	138593	138615	138613	138614	125506
4SHDG75N4	See Motor Kit Table			138579	138602	138585	138610	138593	138615	138613	138614	125506
4SHDG10054	138721	138730		138579	138602	138585	138610	138593	138615	138613	138614	125506
4SHDG100N4	See Motor Kit Table			138579	138602	138585	138610	138593	138615	138613	138614	125506



## **IMPORTANT! WARRANTY REGISTRATION**

Your product is covered by a warranty:

[www.cranepumps.com/downloadables/CATALOGS\\_OIPMs/Warranty/5YearWarranty.pdf](http://www.cranepumps.com/downloadables/CATALOGS_OIPMs/Warranty/5YearWarranty.pdf)

If you have a claim under the provisions of the warranty, contact your local Crane Pumps & Systems, Inc. Distributor.

### **RETURNED GOODS**

**RETURN OF MERCHANDISE REQUIRES A "RETURNED GOODS AUTHORIZATION".  
CONTACT YOUR LOCAL CRANE PUMPS & SYSTEMS, INC. DISTRIBUTOR.**



**Products Returned Must Be Cleaned, Sanitized,  
Or Decontaminated As Necessary Prior To Shipment,  
To Insure That Employees Will Not Be Exposed To Health  
Hazards In Handling Said Material. All Applicable Laws  
And Regulations Shall Apply.**