



Cisco Nexus 9348GC-FXP ACI Mode Hardware Installation Guide

First Published: 2017-09-27

Last Modified: 2019-03-28

Americas Headquarters

Cisco Systems, Inc.
170 West Tasman Drive
San Jose, CA 95134-1706
USA
<http://www.cisco.com>
Tel: 408 526-4000
800 553-NETS (6387)
Fax: 408 527-0883

THE SPECIFICATIONS AND INFORMATION REGARDING THE PRODUCTS REFERENCED IN THIS DOCUMENTATION ARE SUBJECT TO CHANGE WITHOUT NOTICE. EXCEPT AS MAY OTHERWISE BE AGREED BY CISCO IN WRITING, ALL STATEMENTS, INFORMATION, AND RECOMMENDATIONS IN THIS DOCUMENTATION ARE PRESENTED WITHOUT WARRANTY OF ANY KIND, EXPRESS OR IMPLIED.

The Cisco End User License Agreement and any supplemental license terms govern your use of any Cisco software, including this product documentation, and are located at: <http://www.cisco.com/go/softwareterms>. Cisco product warranty information is available at <http://www.cisco.com/go/warranty>. US Federal Communications Commission Notices are found here <http://www.cisco.com/c/en/us/products/us-fcc-notice.html>.

IN NO EVENT SHALL CISCO OR ITS SUPPLIERS BE LIABLE FOR ANY INDIRECT, SPECIAL, CONSEQUENTIAL, OR INCIDENTAL DAMAGES, INCLUDING, WITHOUT LIMITATION, LOST PROFITS OR LOSS OR DAMAGE TO DATA ARISING OUT OF THE USE OR INABILITY TO USE THIS MANUAL, EVEN IF CISCO OR ITS SUPPLIERS HAVE BEEN ADVISED OF THE POSSIBILITY OF SUCH DAMAGES.

Any products and features described herein as in development or available at a future date remain in varying stages of development and will be offered on a when-and if-available basis. Any such product or feature roadmaps are subject to change at the sole discretion of Cisco and Cisco will have no liability for delay in the delivery or failure to deliver any products or feature roadmap items that may be set forth in this document.

Any Internet Protocol (IP) addresses and phone numbers used in this document are not intended to be actual addresses and phone numbers. Any examples, command display output, network topology diagrams, and other figures included in the document are shown for illustrative purposes only. Any use of actual IP addresses or phone numbers in illustrative content is unintentional and coincidental.

The documentation set for this product strives to use bias-free language. For the purposes of this documentation set, bias-free is defined as language that does not imply discrimination based on age, disability, gender, racial identity, ethnic identity, sexual orientation, socioeconomic status, and intersectionality. Exceptions may be present in the documentation due to language that is hardcoded in the user interfaces of the product software, language used based on RFP documentation, or language that is used by a referenced third-party product.

Cisco and the Cisco logo are trademarks or registered trademarks of Cisco and/or its affiliates in the U.S. and other countries. To view a list of Cisco trademarks, go to this URL: [www.cisco.com go trademarks](http://www.cisco.com/go/trademarks). Third-party trademarks mentioned are the property of their respective owners. The use of the word partner does not imply a partnership relationship between Cisco and any other company. (1721R)

© 2017-2018 Cisco Systems, Inc. All rights reserved.



CONTENTS

Trademarks ?

PREFACE

Preface vii

Audience vii

Documentation Conventions vii

Related Documentation viii

Documentation Feedback x

Obtaining Documentation and Submitting a Service Request x

CHAPTER 1

Overview 1

Overview 1

CHAPTER 2

Preparing the Site 5

Temperature Requirements 5

Humidity Requirements 5

Altitude Requirements 5

Dust and Particulate Requirements 6

Minimizing Electromagnetic and Radio Frequency Interference 6

Shock and Vibration Requirements 7

Grounding Requirements 7

Planning for Power Requirements 7

Airflow Requirements 9

Rack and Cabinet Requirements 9

Clearance Requirements 10

CHAPTER 3

Installing the Switch Chassis 13

Safety	13
Installation Options with Rack-Mount Kits	14
Airflow Considerations	14
Installation Guidelines	15
Unpacking and Inspecting the Switch	16
Installing the Switch Using the NXX-ACC-KIT-1RU Rack-Mount Kit	17
Installing the Switch Using the N3K-C3064-ACC-KIT Rack-Mount Kit	20
Installing the Switch into a Two-post Rack	24
Grounding the Chassis	27
Starting the Switch	29

CHAPTER 4

Connecting the Switch to the ACI Fabric	31
ACI Fabric Topology	31
Preparing to Connect to Other Devices	32
Connecting Leaf Switches to APICs	33
Connecting Leaf Switches to Spine Switches	35
Installing a Gigabit Ethernet module (GEM)	36
Virtual Port Channel Migration - Migration of Nodes from a First-Generation Switch to a Second-Generation Switch	36
Setting Up an Optional Console Interface	37
Setting Up an Optional Management Connection	38
Optic Transceiver Removal Using the Optics Extraction Tool	39
Maintaining Transceivers and Optical Cables	40

CHAPTER 5

Replacing Components	41
Replacing a Fan Module	41
Removing a Fan Module	41
Installing a Fan Module	42
Replacing a Power Supply Module	42
Replacing an AC Power Supply	42
Replacing a High Voltage (HVAC/HVDC) Power Supply	43
Replacing a DC Power Supply	45
Wiring the DC Input Power Source	46

APPENDIX A	Rack Specifications	49
	Overview of Racks	49
	General Requirements for Cabinets and Racks	49
	Requirements Specific to Standard Open Racks	50
	Requirements Specific to Perforated Cabinets	50
	Cable Management Guidelines	51

APPENDIX B	System Specifications	53
	Environmental Specifications	53
	Switch Dimensions	53
	Switch and Module Weights and Quantities	54
	Transceiver and Cable Specifications	54
	Switch Power Input Requirements	54
	Power Specifications	55
	350-W AC Power Supply Specifications	55
	350-W PHV Power Supply Specifications	56
	440-W DC Power Supply Specifications	56
	Power Cable Specifications	57
	Power Cable Specifications for AC Power Supplies	57
	DC Power Cable Specifications	58
	Regulatory Standards Compliance Specifications	58

APPENDIX C	LEDs	61
	Switch Chassis LEDs	61
	Fan Module LEDs	62
	Power Supply LEDs	62

APPENDIX D	Additional Kits	65
	Rack Mount Kit for a Two-Post Rack	65
	Rack Mount Kit NXK-ACC-KIT-1RU	65
	Rack Mount Kit N3K-C3064-ACC-KIT	66

APPENDIX E	Site Preparation and Maintenance Records	69
-------------------	---	-----------

Site Preparation Checklist 69

Contact and Site Information 70

Chassis and Module Information 71



Preface

- [Audience, on page vii](#)
- [Documentation Conventions, on page vii](#)
- [Related Documentation, on page viii](#)
- [Documentation Feedback, on page x](#)
- [Obtaining Documentation and Submitting a Service Request , on page x](#)

Audience

This publication is for hardware installers and network administrators who install, configure, and maintain Cisco Nexus switches.

Documentation Conventions

Command descriptions use the following conventions:

Convention	Description
bold	Bold text indicates the commands and keywords that you enter literally as shown.
<i>Italic</i>	Italic text indicates arguments for which the user supplies the values.
[x]	Square brackets enclose an optional element (keyword or argument).
[x y]	Square brackets enclosing keywords or arguments separated by a vertical bar indicate an optional choice.
{x y}	Braces enclosing keywords or arguments separated by a vertical bar indicate a required choice.
[x {y z}]	Nested set of square brackets or braces indicate optional or required choices within optional or required elements. Braces and a vertical bar within square brackets indicate a required choice within an optional element.
variable	Indicates a variable for which you supply values, in context where italics cannot be used.

Convention	Description
string	A nonquoted set of characters. Do not use quotation marks around the string or the string will include the quotation marks.

Examples use the following conventions:

Convention	Description
screen font	Terminal sessions and information the switch displays are in screen font.
boldface screen font	Information you must enter is in boldface screen font.
<i>italic screen font</i>	Arguments for which you supply values are in italic screen font.
<>	Nonprinting characters, such as passwords, are in angle brackets.
[]	Default responses to system prompts are in square brackets.
!, #	An exclamation point (!) or a pound sign (#) at the beginning of a line of code indicates a comment line.

Related Documentation

The Application Centric Infrastructure documentation set includes the following documents that are available on Cisco.com at the following URL:

<https://www.cisco.com/c/en/us/support/cloud-systems-management/application-policy-infrastructure-controller-apic/sd-products-support-series-home.html>

Web-Based Documentation

- *Cisco APIC Management Information Mode Reference*
- *Cisco APIC Online Help Reference*
- *Cisco APIC Python SDK Reference*
- *Cisco ACI Compatibility Tool*
- *Cisco ACI MIB Support List*

Downloadable Documentation

- *Knowledge Base Articles (KB Articles)* are available at the following URL:
<https://www.cisco.com/c/en/us/support/cloud-systems-management/application-policy-infrastructure-controller-apic/products-configuration-examples-list.html>
- *Cisco Application Centric Infrastructure Controller Release Notes*
- *Cisco Application Centric Infrastructure Fundamentals Guide*
- *Cisco APIC Getting Started Guide*
- *Cisco ACI Virtualization Guide*
- *Cisco APIC REST API User Guide*
- *Cisco APIC Command Line Interface User Guide*

- *Cisco APIC Faults, Events, and System Messages Management Guide*
- *Cisco ACI System Messages Reference Guide*
- *Cisco APIC Layer 4 to Layer 7 Services Deployment Guide*
- *Cisco APIC Layer 4 to Layer 7 Device Package Development Guide*
- *Cisco APIC Layer 4 to Layer 7 Device Package Test Guide*
- *Cisco ACI Firmware Management Guide*
- *Cisco ACI Troubleshooting Guide*
- *Cisco ACI Switch Command Reference, NX-OS Release 11.0*
- *Cisco Verified Scalability Guide for Cisco ACI*
- *Cisco ACI MIB Quick Reference*
- *Cisco Nexus CLI to Cisco APIC Mapping Guide*
- *Application Centric Infrastructure Fabric Hardware Installation Guide*
- *Cisco NX-OS Release Notes for Cisco Nexus 9000 Series ACI-Mode Switches*
- *Cisco Nexus 9000 Series ACI Mode Licensing Guide*
- *Cisco Nexus 93108TX-EX ACI-Mode Switch Hardware Installation Guide*
- *Cisco Nexus 93108TX-FX ACI-Mode Switch Hardware Installation Guide*
- *Cisco Nexus 93120TX ACI-Mode Switch Hardware Installation Guide*
- *Cisco Nexus 93128TX ACI-Mode Switch Hardware Installation Guide*
- *Cisco Nexus 93180LC-EX ACI-Mode Switch Hardware Installation Guide*
- *Cisco Nexus 93180YC-EX ACI-Mode Switch Hardware Installation Guide*
- *Cisco Nexus 93180YC-FX ACI-Mode Switch Hardware Installation Guide*
- *Cisco Nexus 9332PQ ACI-Mode Switch Hardware Installation Guide*
- *Cisco Nexus 9336PQ ACI-Mode Switch Hardware Installation Guide*
- *Cisco Nexus 9348GC-FXP ACI-Mode Switch Hardware Installation Guide*
- *Cisco Nexus 9364C ACI-Mode Switch Hardware Installation Guide*
- *Cisco Nexus 9372PX and 9372PX-E ACI-Mode Switches Hardware Installation Guide*
- *Cisco Nexus 9372TX and 9372TX-E ACI-Mode Switches Hardware Installation Guide*
- *Cisco Nexus 9396PX ACI-Mode Switch Hardware Installation Guide*
- *Cisco Nexus 9396TX ACI-Mode Switch Hardware Installation Guide*
- *Cisco Nexus 9504 ACI-Mode Switch Hardware Installation Guide*
- *Cisco Nexus 9508 ACI-Mode Switch Hardware Installation Guide*
- *Cisco Nexus 9516 ACI-Mode Switch Hardware Installation Guide*

Cisco Application Centric Infrastructure (ACI) Simulator Documentation

The following Cisco ACI Simulator documentation is available at

<https://www.cisco.com/c/en/us/support/cloud-systems-management/application-centric-infrastructure-simulator/tsd-products-support-series-home.html>

- *Cisco ACI Simulator Release Notes*
- *Cisco ACI Simulator Installation Guide*
- *Cisco ACI Simulator Getting Started Guide*

Cisco Nexus 9000 Series Switches Documentation

The Cisco Nexus 9000 Series Switches documentation is available at

<https://www.cisco.com/c/en/us/support/switches/nexus-9000-series-switches/tsd-products-support-series-home.html>

Cisco Application Virtual Switch Documentation

The Cisco Application Virtual Switch (AVS) documentation is available at

<https://www.cisco.com/c/en/us/support/switches/application-virtual-switch/tsd-products-support-series-home.html>

Documentation Feedback

To provide technical feedback on this document, or to report an error or omission, please send your comments to apic-docfeedback@cisco.com. We appreciate your feedback.

Obtaining Documentation and Submitting a Service Request

For information on obtaining documentation, using the Cisco Bug Search Tool (BST), submitting a service request, and gathering additional information, see *What's New in Cisco Product Documentation*, at: <https://www.cisco.com/warp/public/687/Directory/DirTAC.shtml>.

Subscribe to *What's New in Cisco Product Documentation*, which lists all new and revised Cisco technical documentation as an RSS feed and delivers content directly to your desktop using a reader application. The RSS feeds are a free service.



CHAPTER 1

Overview

- [Overview, on page 1](#)

Overview

The Cisco Nexus 9348GC-FXP switch (N9K-C9348GC-FXP) is a 1-RU fixed-port, L2/L3 switch, designed for ACI deployments. This switch has 48 10/100/1000-Megabit 1GBASE-T host ports, 4 1/10-/25-Gigabit SFP28 host ports, and 2 40-/100-Gigabit QSFP28 uplink ports.



Note Autonegotiation is supported on 100M/1G/10G ports.

The chassis for this switch includes the following user-replaceable components:

- Fan modules (three) with the following airflow choices:
 - Port-side intake airflow with burgundy coloring (NXA-FAN-30CFM-B)
 - Port-side exhaust airflow with blue coloring (NXA-FAN-30CFM-F)



Note
Table 1: Fan Speeds for this Switch

	Port-Side Intake Fan Speed %	Port-Side Exhaust Fan Speed %
Typical/Minimum	50%	70%
Maximum	100%	100%

- Power supply modules (two—one for operations and one for redundancy [1+1]) with the following choices (do not mix AC and DC power sources and do not mix airflow directions):
 - 350-W AC power supply with port-side intake airflow (burgundy coloring) (NXA-PAC-350W-PI)
 - 350-W AC power supply with port-side exhaust airflow (blue coloring) (NXA-PAC-350W-PE)

- 350-W HVAC/HVDC power supply with port-side intake airflow (blue coloring) (NXA-PHV-350W-PI)
- 350-W HVAC/HVDC power supply with port-side exhaust airflow (blue coloring) (NXA-PHV-350W-PE)
- 440-W DC power supply with port-side exhaust airflow (burgundy coloring) (NXA-PDC-440W-PI)
- 440-W DC power supply with port-side exhaust airflow (blue coloring) (NXA-PDC-440W-PE)



Note The 350-W AC power supply does not have the standby voltage to be able to carry to a second power supply, to allow it to communicate and poll the device.

The following figure shows the hardware features seen from the port side of the chassis.

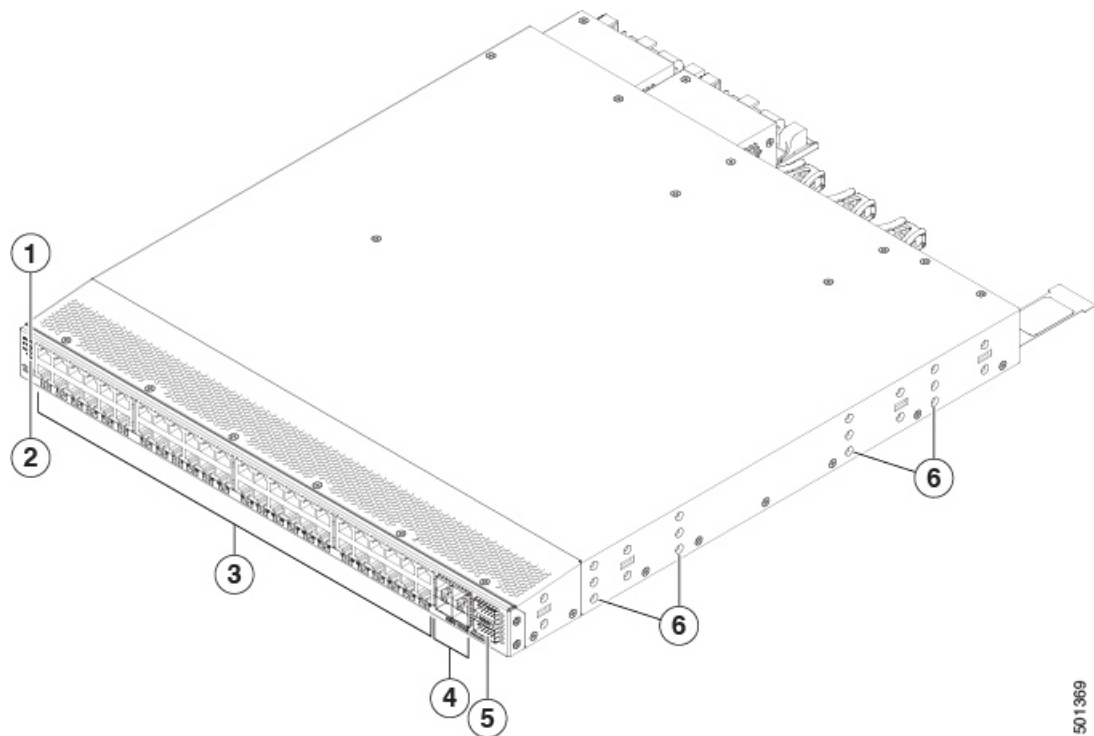

1	Chassis LEDs (Beacon [BCN], Status [STS], and Environment [ENV])	4	10-/25-Gigabit SFP28 host ports (4)
2	LED (P) designated for possible future use	5	40-/100-Gigabit QSFP28 uplink ports (2)
3	10/100-/1000-Megabit 1GBASE-T host ports (48)	6	Screw holes (6) for attaching rack mounting brackets

To determine which transceivers, adapters, and cables this switch supports, see the [Cisco Transceiver Modules Compatibility Information](#) document.

The following figure shows the hardware features seen from the power supply side of the chassis.

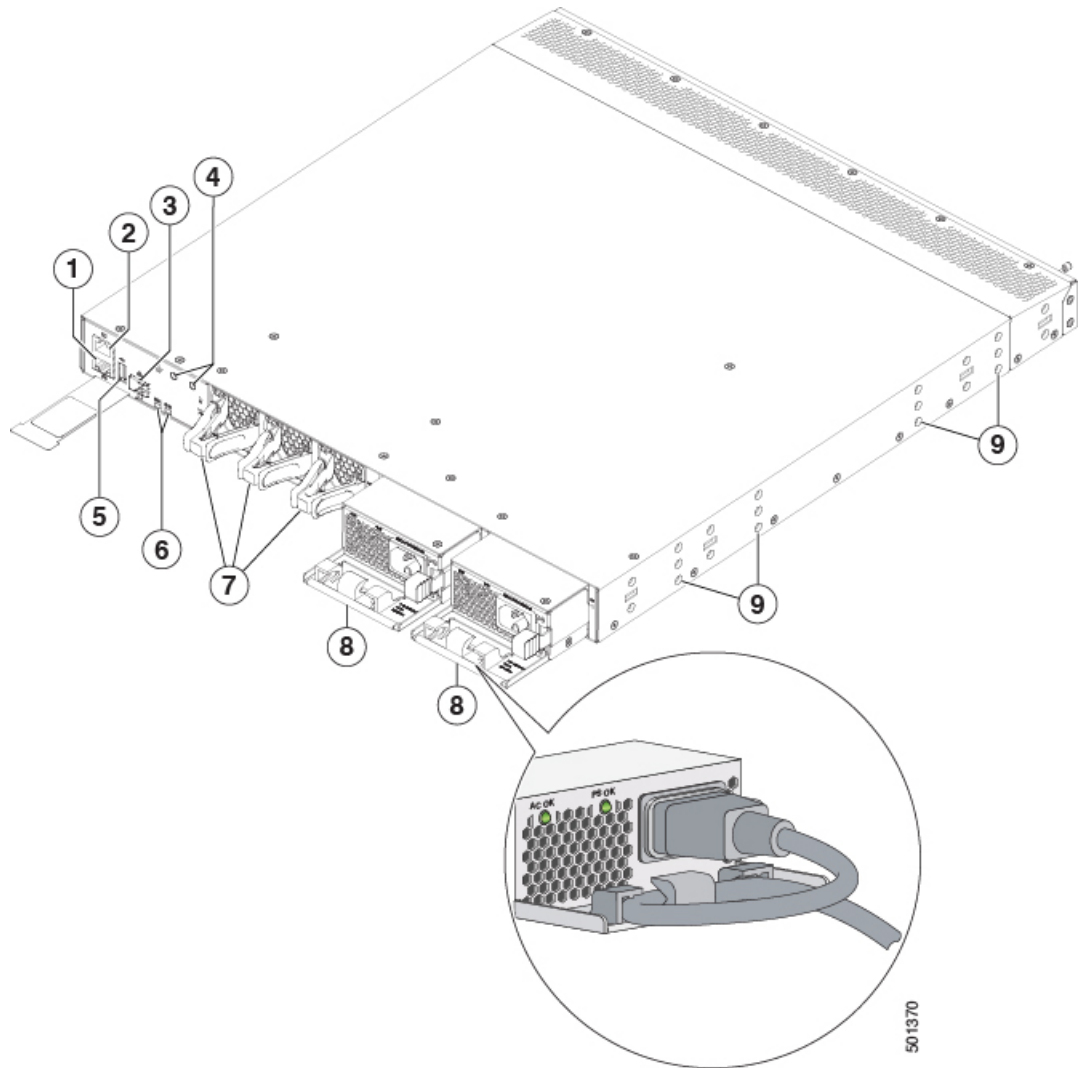

1	Management port (RJ-45 port)	6	Chassis LEDs (Beacon [BCN] and Status [STS])
2	Console port (RS-232 port)	7	Fan module (3) with fan slot 1 on the left and fan slot 3 on the right
3	Management port (SFP port)	8	Power supply (2) one used for operations and one used for redundancy, with power supply slot 1 on the left and slot 2 on the right
4	Grounding pad	9	Screw holes (6) for attaching rack mounting brackets
5	USB port		



Note USB support is limited to USB 2.0 devices that use less than 2.5 W (less than 0.5 A inclusive of surge current). Devices, such as external hard drives, that instantaneously draw more than 0.5 A are not supported.

Depending on whether you plan to position the ports in a hot or cold aisle, you can order the fan and power supply modules with port-side intake or port-side exhaust airflow. To determine the airflow direction of the modules installed in your switch, see the following table.

Replaceable Modules	Port-Side Intake Airflow Coloring	Port-Side Exhaust Airflow Coloring
Fans	Burgundy	Blue
AC power supplies	Burgundy	Blue

The fan and power supply modules are field replaceable. You can replace one fan module or one power supply module during operations, so long as the other modules are installed and operating. If you have only one power supply installed, you can install the replacement power supply in the open slot before removing the original power supply.



Note All of the fan and power supply modules must have the same direction of airflow. Otherwise, the switch can overheat and shut down. If you are installing a dual-direction power supply, that module automatically uses the same airflow direction as the other modules in the switch.



Caution If the switch has port-side intake airflow (burgundy coloring for fan modules), you must locate the ports in the cold aisle. If the switch has port-side exhaust airflow (blue coloring for fan modules), you must locate the ports in the hot aisle. If you locate the air intake in a hot aisle, the switch can overheat and shut down.



CHAPTER 2

Preparing the Site

- [Temperature Requirements, on page 5](#)
- [Humidity Requirements, on page 5](#)
- [Altitude Requirements, on page 5](#)
- [Dust and Particulate Requirements, on page 6](#)
- [Minimizing Electromagnetic and Radio Frequency Interference, on page 6](#)
- [Shock and Vibration Requirements, on page 7](#)
- [Grounding Requirements, on page 7](#)
- [Planning for Power Requirements, on page 7](#)
- [Airflow Requirements, on page 9](#)
- [Rack and Cabinet Requirements, on page 9](#)
- [Clearance Requirements, on page 10](#)

Temperature Requirements

The switch requires an operating temperature of 32 to 104 degrees Fahrenheit (0 to 40 degrees Celsius). If the switch is not operating, the temperature must be between –40 to 158 degrees Fahrenheit (–40 to 70 degrees Celsius).

Humidity Requirements

High humidity can cause moisture to enter the switch. Moisture can cause corrosion of internal components and degradation of properties such as electrical resistance, thermal conductivity, physical strength, and size. The switch is rated to withstand from 5- to 95-percent (noncondensing) relative humidity.

Buildings in which the climate is controlled by air-conditioning in the warmer months and by heat during the colder months usually maintain an acceptable level of humidity for the switch equipment. However, if the switch is located in an unusually humid location, use a dehumidifier to maintain the humidity within an acceptable range.

Altitude Requirements

Altitude rating is based on power supply installed; see critical components list in the system CB report for altitude rating.

Dust and Particulate Requirements

Exhaust fans cool power supplies and system fans cool switches by drawing in air and exhausting air out through various openings in the chassis. However, fans also ingest dust and other particles, causing contaminant buildup in the switch and increased internal chassis temperature. Dust and particles can act as insulators and interfere with the mechanical components in the switch. A clean operating environment can greatly reduce the negative effects of dust and other particles.

In addition to keeping your environment free of dust and particles, follow these precautions to avoid contamination of your switch:

- Do not permit smoking near the switch.
- Do not permit food or drink near the switch.

Minimizing Electromagnetic and Radio Frequency Interference

Electromagnetic interference (EMI) and radio frequency interference (RFI) from the switch can adversely affect other devices, such as radio and television (TV) receivers. Radio frequencies that emanate from the switch can also interfere with cordless and low-power telephones. Conversely, RFI from high-power telephones can cause spurious characters to appear on the switch monitor.

RFI is defined as any EMI with a frequency above 10 kHz. This type of interference can travel from the switch to other devices through the power cable and power source or through the air as transmitted radio waves. The Federal Communications Commission (FCC) publishes specific regulations to limit the amount of EMI and RFI that are emitted by computing equipment. Each switch meets these FCC regulations.

To reduce the possibility of EMI and RFI, follow these guidelines:

- Cover all open expansion slots with a blank filler plate.
- Always use shielded cables with metal connector shells for attaching peripherals to the switch.

When wires are run for any significant distance in an electromagnetic field, interference can occur to the signals on the wires with the following implications:

- Bad wiring can result in radio interference emanating from the plant wiring.
- Strong EMI, especially when it is caused by lightning or radio transmitters, can destroy the signal drivers and receivers in the chassis and even create an electrical hazard by conducting power surges through lines into equipment.



Note

To predict and prevent strong EMI, you need to consult experts in radio frequency interference (RFI).

The wiring is unlikely to emit radio interference if you use a twisted-pair cable with a good distribution of grounding conductors. If you exceed the recommended distances, use a high-quality twisted-pair cable with one ground conductor for each data signal when applicable.

**Caution**

If the wires exceed the recommended distances, or if wires pass between buildings, give special consideration to the effect of a lightning strike in your vicinity. The electromagnetic pulse that is caused by lightning or other high-energy phenomena can easily couple enough energy into unshielded conductors to destroy electronic switches. You will want to consult experts in electrical surge suppression and shielding if you had similar problems in the past.

Shock and Vibration Requirements

The switch has been shock- and vibration-tested for operating ranges, handling, and earthquake standards.

Grounding Requirements

The switch is sensitive to variations in voltage that is supplied by the power sources. Overvoltage, undervoltage, and transients (or spikes) can erase data from memory or cause components to fail. To protect against these types of problems, ensure that there is an earth-ground connection for the switch. You can connect the grounding pad on the switch either directly to the earth-ground connection or to a fully bonded and grounded rack.

When you properly install the chassis in a grounded rack, the switch is grounded because it has a metal-to-metal connection to the rack. Alternatively, you can ground the chassis by using a customer-supplied grounding cable that meets your local and national installation requirements. For U.S. installations, we recommend 6-AWG wire. Connect your grounding cable to the chassis with a grounding lug (provided in the switch accessory kit) and to the facility ground.

**Note**

You automatically ground AC power supplies when you connect them to AC power sources. For DC power supplies, you must connect a grounding wire when wiring the power supply to the DC power source.

**Note**

An electrical conducting path shall exist between the product chassis and the metal surface of the enclosure or rack in which it is mounted or to a grounding conductor. Electrical continuity shall be provided by using thread-forming type mounting screws that remove any paint or non-conductive coatings and establish a metal-to-metal contact. Any paint or other non-conductive coatings shall be removed on the surfaces between the mounting hardware and the enclosure or rack. The surfaces shall be cleaned and an antioxidant applied before installation.

Planning for Power Requirements

The switch includes two power supplies (1-to-1 redundancy with current sharing) in one of the following combinations:

- Two 350-W AC power supplies
- Two 440-W DC power supplies



Note For $n+1$ redundancy, you can use one or two power sources for the two power supplies. For $n+n$ redundancy, you must use two power sources and connect each power supply to a separate power source.

The power supplies are rated to output up to 350 W (AC power supplies) or up to 440 W (DC power supplies), but the switch requires less than those amounts of power from the power supply. To operate the switch, you must provision enough power from the power source to cover the requirements of both the switch and a power supply. Typically, this switch and a power supply require about 200 W of power input from the power source, but you must provision as much as 443 W power input from the power source to cover peak demand.



Note Some of the power supply modules have rating capabilities that exceed the switch requirements. When calculating your power requirements, use the switch requirements to determine the amount of power that is required for the power supplies.

To minimize the possibility of circuit failure, make sure that each power-source circuit that is used by the switch is dedicated to the switch.



Note For AC input application, please refer to the following statement:



Warning **Statement 1005**—Circuit Breaker

This product relies on the building's installation for short-circuit (overcurrent) protection. Ensure that the protective devices are rated not greater than 20A (North America), 16A (Europe), and 13A (UK).



Note For DC input application, please refer to the following statement:



Warning **Statement 1005**—Circuit Breaker

This product relies on the building's installation for short-circuit (overcurrent) protection.

- Ensure that the protective devices are rated not greater than 30A when the switch is powered with regular DC power supplies (rated 48-60VDC).
 - Ensure that the protective devices are rated not greater than 10A when the switch is powered with HVDC power supplies (rated 240-350VDC).
-



Warning **Statement 1033**

Connect the unit only to DC power source that complies with the Safety Extra-Low Voltage (SELV) requirements in IEC 60950 based safety standards.



Note We recommend 8-AWG wire for DC installations in the U.S.



Note For the power cables to use with the power supplies, see [Power Cable Specifications, on page 57](#).

Airflow Requirements

The switch is positioned with its ports in either the front or the rear of the rack depending on your cabling and maintenance requirements. You must have fan and power supply modules that move the coolant air from the cold aisle to the hot aisle in one of the following ways:

- Port-side exhaust airflow—Cool air enters the chassis through the fan and power supply modules in the cold aisle and exhausts through the port end of the chassis in the hot aisle.
- Port-side intake airflow—Cool air enters the chassis through the port end in the cold aisle and exhausts through the fan and power supply modules in the hot aisle.

You can identify the airflow direction of each fan and power supply module by its coloring as follows:

- Blue coloring indicates port-side exhaust airflow.
- Burgundy coloring indicates port-side intake airflow.
- White coloring on HVAC/HVDC power supplies indicates dual-direction airflow.



Note To prevent the switch from overheating and shutting down, you must position the air intake for the switch in a cold aisle. The fan and power supply modules must have the same direction of airflow (even if their coloring is different). If you must change the airflow direction for the switch, you must shutdown the switch before changing the modules.

Rack and Cabinet Requirements

You can install the following types of racks or cabinets for your switch:

- Standard perforated cabinets
- Solid-walled cabinets with a roof fan tray (bottom-to-top cooling)
- Standard open four-post Telco racks

Work with your cabinet vendors to determine which of their cabinets meet the following requirements or see the Cisco Technical Assistance Center (TAC) for recommendations:

- Use a standard 19-inch (48.3-cm), four-post Electronic Industries Alliance (EIA) cabinet or rack with mounting rails that conform to English universal hole spacing per section 1 of the ANSI/EIA-310-D-1992 standard.
- The depth of a four-post rack must be 24 to 32 inches (61.0 to 81.3 cm) between the front and rear mounting rails (for proper mounting of the bottom-support brackets or other mounting hardware).
- Required clearances between the chassis and the edges of its rack or the interior of its cabinet are as follows:
 - 4.5 inches (11.4 cm) between the front of the chassis and the interior of the cabinet (required for cabling).
 - 3.0 inches (7.6 cm) between the rear of the chassis and the interior of the cabinet (required for airflow in the cabinet if used).
 - No clearance is required between the chassis and the sides of the rack or cabinet (no side airflow).

Also, you must have power receptacles that are located within reach of the power cords that are used with the switch.



Warning Statement 1048—Rack Stabilization

The rack stabilizing mechanism must be in place, or the rack must be bolted to the floor before installation or servicing. Failure to stabilize the rack can cause bodily injury.

Clearance Requirements

Provide the chassis with adequate clearance between the chassis and any other rack, device, or structure so that you can properly install the chassis. Provide the chassis with adequate clearance to route cables, provide airflow, and maintain the switch. For the clearances required for an installation of this chassis in a four-post rack, see the following figure.

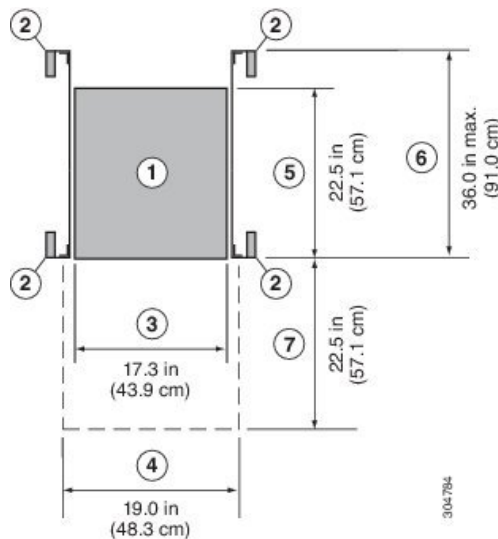

1	Chassis	5	Depth of the chassis
2	Vertical rack-mount posts and rails	6	Maximum extension of the bottom-support rails 36.0 in (91.0 cm)
3	Chassis width 17.3 in (43.9 cm)	7	Depth of the front clearance area (equal to the depth of the chassis).
4	Width of the front clearance area (equal to the width of the chassis with two rack-mount brackets that are attached to it). 19.0 in (48.3 cm)		



Note Both the front and rear of the chassis must be open to both aisles for airflow.



CHAPTER 3

Installing the Switch Chassis

- [Safety](#), on page 13
- [Installation Options with Rack-Mount Kits](#), on page 14
- [Airflow Considerations](#), on page 14
- [Installation Guidelines](#), on page 15
- [Unpacking and Inspecting the Switch](#), on page 16
- [Installing the Switch Using the NXK-ACC-KIT-1RU Rack-Mount Kit](#), on page 17
- [Installing the Switch Using the N3K-C3064-ACC-KIT Rack-Mount Kit](#), on page 20
- [Installing the Switch into a Two-post Rack](#), on page 24
- [Grounding the Chassis](#), on page 27
- [Starting the Switch](#), on page 29

Safety

Before you install, operate, or service the switch, see the *Regulatory, Compliance, and Safety Information for the Cisco Nexus 3000 and 9000 Series* for important Safety Information.



Warning Statement 1071—Warning Definition

IMPORTANT SAFETY INSTRUCTIONS

Before you work on any equipment, be aware of the hazards involved with electrical circuitry and be familiar with standard practices for preventing accidents. Read the installation instructions before using, installing, or connecting the system to the power source. Use the statement number provided at the end of each warning statement to locate its translation in the translated safety warnings for this device.

SAVE THESE INSTRUCTIONS





Warning **Statement 1017**—Restricted Area

This unit is intended for installation in restricted access areas. Only skilled, instructed, or qualified personnel can access a restricted access area.



Warning **Statement 1030**—Equipment Installation

Only trained and qualified personnel should be allowed to install, replace, or service this equipment.

Installation Options with Rack-Mount Kits

The rack-mount kit enables you to install the switch into racks of varying depths. You can position the switch with easy access to either the port connections or the fan and power supply modules.

You can install the switch using the following rack-mount options:

- Rack-mount kit (NXK-ACC-KIT-1RU) which you can order from Cisco. This option offers you easy installation, greater stability, increased weight capacity, added accessibility, and improved removability with front and rear removal.
 - When installing the NXK-ACC-KIT-1RU rack-mount kit, the distance between the outside face of the front mounting rail and the outside face of the back mounting rail should be 25.37 to 33 inches (64.43 to 83.82 cm) to allow for rear-bracket installation.
- Rack-mount kit (N3K-C3064-ACC-KIT) which you can order from Cisco.
 - When installing the N3K-C3064-ACC-KIT rack-mount kit, the distance between the outside face of the front mounting rail and the outside face of the back mounting rail should be 22 to 30 inches (55.88 to 76.2 cm) to allow for rear-bracket installation.

The rack or cabinet that you use must meet the requirements listed in [General Requirements for Cabinets and Racks](#), on page 49 section.



Note You are responsible for verifying that your rack and rack-mount hardware comply with the guidelines that are described in this doc.

Airflow Considerations

The switch comes with fan and power supply modules that have either port-side intake or port-side exhaust airflow for cooling the switch. If you are positioning the port end of the switch in a cold aisle, make sure that the switch has port-side intake fan modules with burgundy coloring. If you are positioning the fan and power supply modules in a cold aisle, make sure that the switch has port-side exhaust fan modules with blue colorings. All fan modules must have the same direction of airflow.

Installation Guidelines

When installing the switch, follow these guidelines:

- Ensure that there is adequate clearance space around the switch to allow for servicing the switch and for adequate airflow.
- Ensure that you are positioning the switch in a rack so that it takes in cold air from the cold aisle and exhausts air to the hot aisle. If there is blue coloring on the fan modules, the switch is configured for port-side exhaust airflow and you must position the module side of the switch in a cold aisle. If there is burgundy coloring on the fan modules, the switch is configured for port-side intake airflow and you must position the port side of the switch in a cold aisle.
- Ensure that the chassis can be adequately grounded. If the switch is not mounted in a grounded rack, we recommend connecting the system ground on the chassis directly to an earth ground.
- Ensure that the site power meets the power requirements for the switch. If available, you can use an uninterruptible power supply (UPS) to protect against power failures.



Caution Avoid UPS types that use ferroresonant technology. These UPS types can become unstable with the switch, which can have substantial current draw fluctuations because of fluctuating data traffic patterns.

- Ensure that circuits are sized according to local and national codes. Typically, this often requires one or both of the following:
 - AC power supplies typically require at least a 15-A or 20-A AC circuit, 100 to 240 VAC, and a frequency of 50 to 60 Hz.



Caution To prevent loss of input power, ensure the total maximum loads on the circuits supplying power to the switch are within the current ratings for the wiring and breakers.



Note For AC input application, please refer to the statement below:



Warning **Statement 1005**—Circuit Breaker

This product relies on the building's installation for short-circuit (overcurrent) protection. Ensure that the protective devices is rated not greater than 20A (North America), 16A (Europe), and 13A (UK).



Note For DC input application, please refer to the statement below:

**Warning Statement 1005**—Circuit Breaker

This product relies on the building's installation for short-circuit (overcurrent) protection. Ensure that the protective devices is rated not greater than 40A for the regular DC power supplies (rated 48-60VDC) and 10A for the HVDC power supplies.

Unpacking and Inspecting the Switch

Before you install the switch, be sure to unpack and inspect the switch for damage or missing components. If anything is missing or damaged, contact your customer service representative immediately.



Tip Keep the shipping container in case the chassis requires shipping at a later time.

Before you begin

Before you unpack the switch and before you handle any switch components, be sure that you are wearing a grounded electrostatic discharge (ESD) strap. To ground the strap, attach it directly to an earth ground or to a grounded rack or grounded chassis (there must be a metal-to-metal connection to the earth ground).

-
- Step 1** Compare the shipment to the equipment list provided by your customer service representative and verify that you have received all items, including the following:
- Accessory Kit
 - Rack-Mount Kit
- Step 2** Check for damage and report any discrepancies or damage to your customer service representative. Have the following information ready:
- Invoice number of shipper (see packing slip)
 - Model and serial number of the damaged unit
 - Description of damage
 - Effect of damage on the installation
- Step 3** Check to be sure that each of the power supply and the fan tray modules have the expected direction of airflow as follows:
- Port-side intake airflow modules
 - Burgundy (fan modules and AC power supplies)
 - Port-side exhaust airflow modules
 - Blue (fan modules and AC power supplies)

Note All power supplies and fan modules must have the same direction of airflow.

Installing the Switch Using the NXK-ACC-KIT-1RU Rack-Mount Kit

To install the switch, you must attach front and rear mounting brackets to the switch, install slider rails on the rear of the rack, slide the switch onto the slider rails, and secure the switch to the front of the rack. Typically, the front of the rack is the side easiest to access for maintenance.



Note You must supply the eight 10-32 or 12-24 screws required to mount the slider rails and switch to the rack.

Before you begin

- You have inspected the switch shipment to ensure that you have everything ordered.
- Make sure that the switch rack-mount kit includes the following parts:
 - Front rack-mount brackets (2)
 - Rear rack-mount brackets (2)
 - Slider rails (2)
 - M4 x 0.7 x 8-mm Phillips countersink screws (12)
- The rack is installed and secured to its location.

Step 1

Install two front rack-mount brackets and the two rear rack-mount brackets to the switch as follows:

a) Determine which end of the chassis is to be located in the cold aisle as follows:

- If the switch has port-side intake modules (fan modules with burgundy coloring), position the switch so that its ports will be in the cold aisle.
- If the switch has port-side exhaust modules (fan modules with blue coloring), position the switch so that its fan and power supply modules will be in the cold aisle.

b) Position the front rack-mount bracket and the rear rack-mount bracket so that its screw holes are aligned to the screw holes on the side of the chassis.

Note You can align the holes in the rack-mount bracket to the holes on the side of the chassis (see the two ways to mount these brackets on a typical chassis, in following figure). The holes that you use depend on the requirements of your rack and the amount of clearance required for interface cables (3 inches [7.6 mm] minimum) and module handles (1 inch [2.5 mm] minimum).

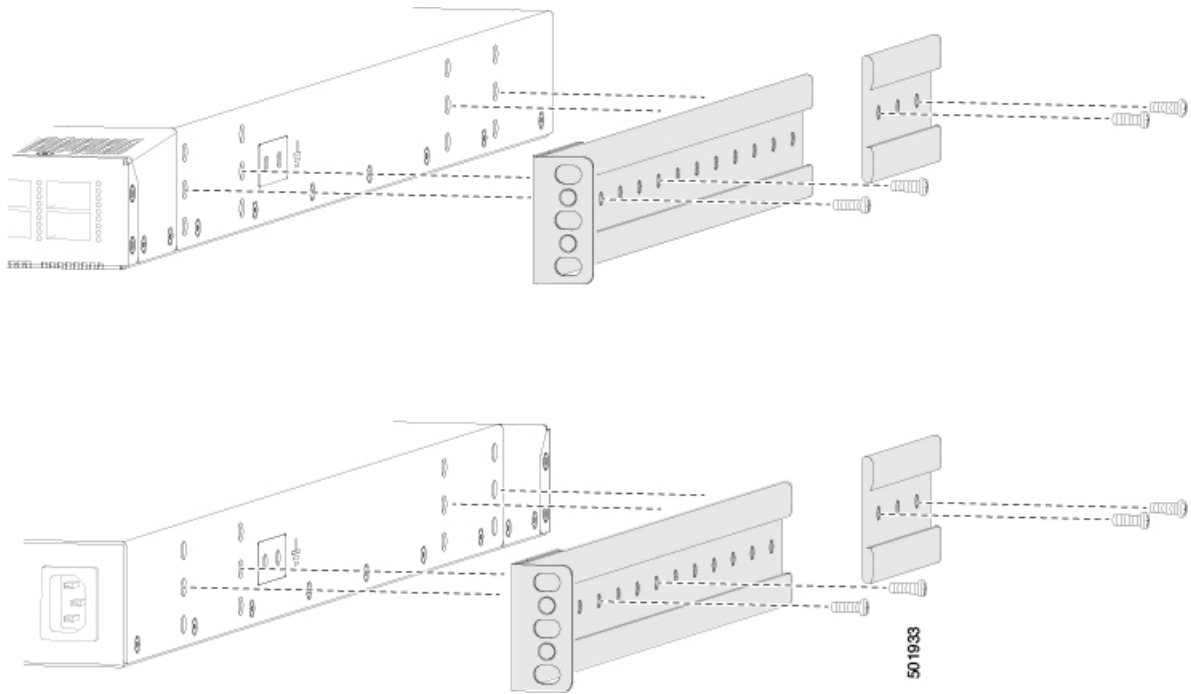

- c) Secure the front-mount bracket and the back-mount bracket to the chassis using four M4 screws and tighten each screw to 12 in-lb (1.36 N·m) of torque.
- d) Repeat Step 1 for the other front rack-mount bracket and the other back-mount bracket on the other side of the switch and be sure to position that bracket the same distance from the front of the switch.

Note Depending on the chassis depth, the back rack-mount bracket may not fit. In that case the back rack-mount bracket is not needed.

Step 2 If you are not installing the chassis into a grounded rack, you must attach a customer-supplied grounding wire to the chassis as explained in the [Grounding the Chassis, on page 27](#) section. If you are installing the chassis into a grounded rack, you can skip this step.

Step 3 Install the slider rails on the rack or cabinet as follows:

- a) Determine which two posts of the rack or cabinet you should use for the slider rails. Of the four vertical posts in the rack or cabinet, two will be used for the front mount brackets attached to the easiest accessed end of the chassis, and the other two posts will have the slider rails.
- b) Position a slider rail at the desired level on the back side of the rack and use 12-24 screws or 10-32 screws, depending on the rack thread type, to attach the rails to the rack (see the following figure). Tighten 12-24 screws to 30 in-lb (3.39 N·m) of torque and tighten 10-32 screws to 20 in-lb (2.26 N·m) of torque.

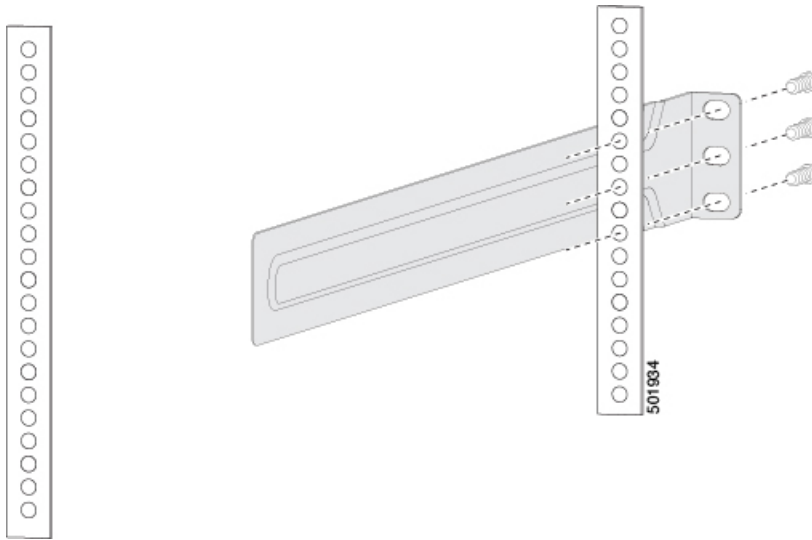

- c) Repeat Step 3 to attach the other slider rail to the other side of the rack.

To make sure that the slider rails are at the same level, you should use a level tool, tape measure, or carefully count the screw holes in the vertical mounting rails.

Step 4 Insert the switch into the rack and attach it as follows:

- a) Holding the switch with both hands, position the two rear rack-mount brackets on the switch between the rack or cabinet posts that do not have slider rails attached to them (see the following figure).

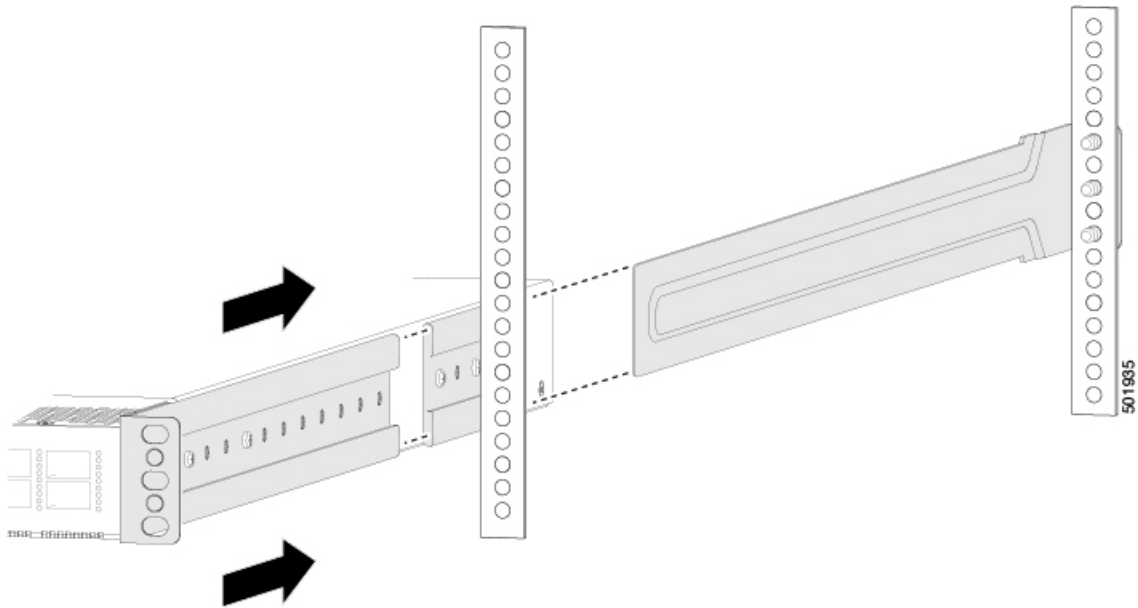

- b) Align the two rear rack-mount guides on either side of the switch with the slider rails installed in the rack. Slide the rack-mount guides onto the slider rails, and then gently slide the switch all the way into the rack until the front rack-mount brackets come in contact with two rack or cabinet posts.
- c) Holding the chassis level, insert screws (12-24 or 10-32, depending on the rack type) in each of the two front rack-mount brackets (using a total of six screws) and into the cage nuts or threaded holes in the vertical rack-mounting rails (see the following figure).

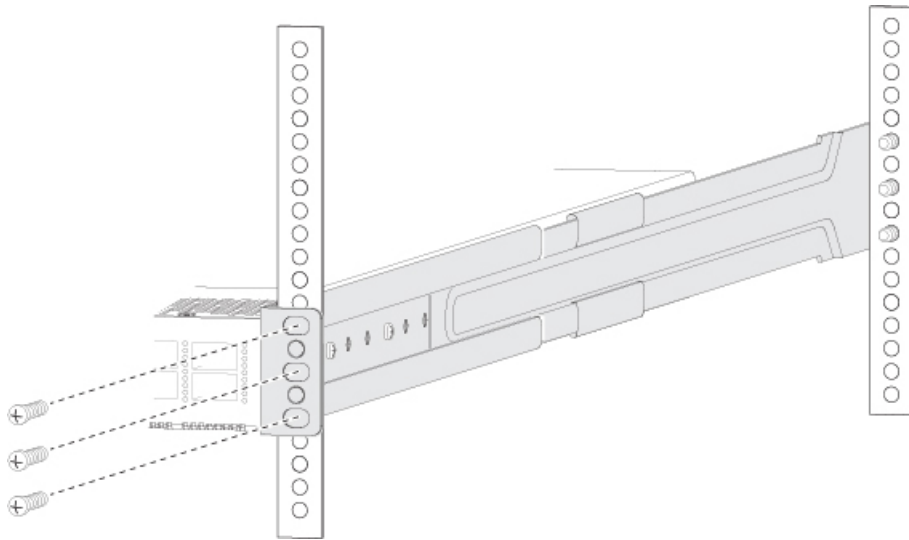

d) Tighten the 10-32 screws to 20 in-lb (2.26 N·m) or tighten the 12-24 screws to 30 in-lb (3.39 N·m).

Step 5

If you attached a grounding wire to the chassis grounding pad, connect the other end of the wire to the facility ground.

Installing the Switch Using the N3K-C3064-ACC-KIT Rack-Mount Kit

To install the switch, you must attach front and rear mounting brackets to the switch, install slider rails on the rear of the rack, slide the switch onto the slider rails, and secure the switch to the front of the rack. Typically, the front of the rack is the side easiest to access for maintenance.



Note You must supply the eight 10-32 or 12-24 screws required to mount the slider rails and switch to the rack.

Before you begin

- You have inspected the switch shipment to ensure that you have everything ordered.
- Make sure that the switch rack-mount kit includes the following parts:
 - Front rack-mount brackets (2)
 - Rear rack-mount brackets (2)
 - Slider rails (2)
 - M4 x 0.7 x 8-mm Phillips countersink screws (12)
- The rack is installed and secured to its location.

Step 1

Install two front-mount brackets to the switch as follows:

a) Determine which end of the chassis is to be located in the cold aisle as follows:

- If the switch has port-side intake modules (fan modules with burgundy coloring), position the switch so that its ports will be in the cold aisle.
- If the switch has port-side exhaust modules (fan modules with blue coloring), position the switch so that its fan and power supply modules will be in the cold aisle.

b) Position a front-mount bracket so that four of its screw holes are aligned to the screw holes on the side of the chassis.

Note You can align any four of the holes in the front rack-mount bracket to four of the six screw holes on the side of the chassis (see the two ways to mount these brackets on a typical chassis, in following figure). The holes that you use depend on the requirements of your rack and the amount of clearance required for interface cables (3 inches [7.6 mm] minimum) and module handles (1 inch [2.5 mm] minimum).

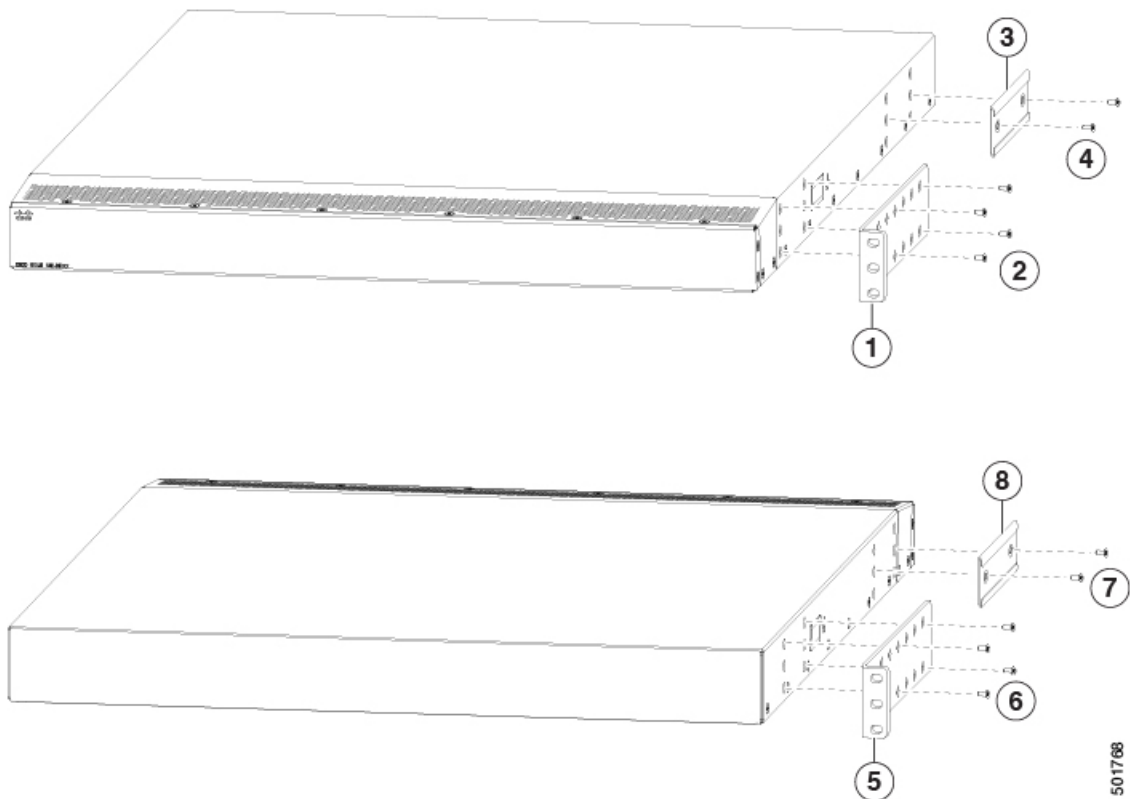

1	Front rack-mount bracket aligned to the port end of the chassis	5	Front rack-mount bracket aligned to the module end of the chassis
2	Four M4 screws used to attach the bracket to the chassis	6	Four M4 screws used to attach the bracket to the chassis
3	Rear rack-mount guide aligned to the module end of the chassis	7	Two M4 screws used to attach the bracket to the chassis

4	Two M4 screws used to attach the bracket to the chassis	8	Rear rack-mount guide aligned to the port end of the chassis
---	---	---	--

- c) Secure the front-mount bracket to the chassis using four M4 screws and tighten each screw to 12 in-lb (1.36 N·m) of torque.
- d) Repeat Step 1 for the other front rack-mount bracket on the other side of the switch and be sure to position that bracket the same distance from the front of the switch.

Step 2 Install the two rear rack-mount brackets on the chassis as follows:

- a) Align the two screw holes on a rear rack-mount bracket to the middle two screw holes in the remaining six screw holes on a side of the chassis. If you are aligning the guide to holes that are near the port connections end of the chassis, see Callout 3 in the previous figure. Otherwise, see Callout 7 in the previous figure.
- b) Attach the guide to the chassis using two M4 screws (see Callout 4 or 8 in the previous figure). Tighten the screws to 12 in-lb (1.36 N·m) of torque.
- c) Repeat Step 2 for the other rear rack-mount bracket on the other side of the switch.

Step 3 If you are not installing the chassis into a grounded rack, you must attach a customer-supplied grounding wire to the chassis as explained in the [Grounding the Chassis, on page 27](#) section.. If you are installing the chassis into a grounded rack, you can skip this step.

Step 4 Install the slider rails on the rack or cabinet as follows:

- a) Determine which two posts of the rack or cabinet you should use for the slider rails. Of the four vertical posts in the rack or cabinet, two will be used for the front mount brackets attached to the easiest accessed end of the chassis, and the other two posts will have the slider rails.
- b) Position a slider rail at the desired level on the back side of the rack and use two 12-24 screws or two 10-32 screws, depending on the rack thread type, to attach the rails to the rack (see the following figure). Tighten 12-24 screws to 30 in-lb (3.39 N·m) of torque and tighten 10-32 screws to 20 in-lb (2.26 N·m) of torque.

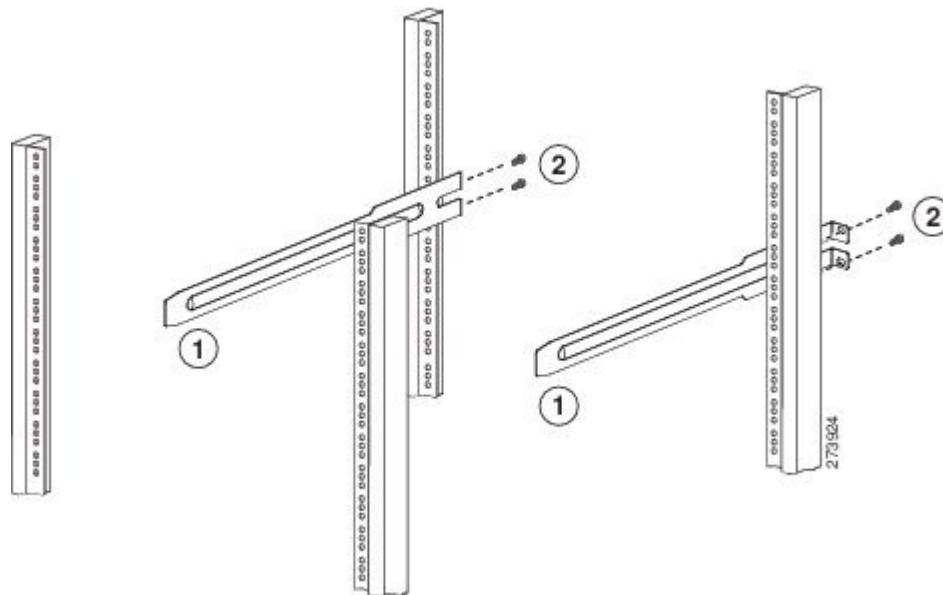

1	Slider rail with screw holes aligned to screw holes in rack	2	Two customer-supplied 12-24 or 10-32 screws used to attach each slider rail to the rack
---	---	---	---

- c) Repeat Step 3 to attach the other slider rail to the other side of the rack.

To make sure that the slider rails are at the same level, you should use a level tool, tape measure, or carefully count the screw holes in the vertical mounting rails.

Step 5 Insert the switch into the rack and attach it as follows:

- a) Holding the switch with both hands, position the two rear rack-mount brackets on the switch between the rack or cabinet posts that do not have slider rails attached to them (see the following figure).

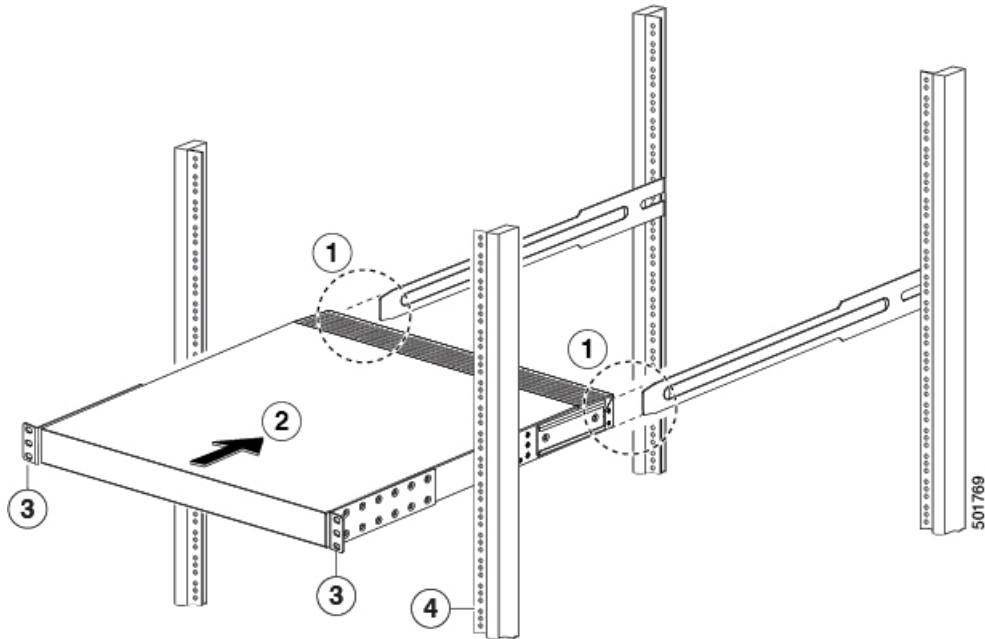

1	Align the two rear rack-mount bracket guides with the slider rails installed in the rack.	3	Front-mount brackets.
2	Slide the rack-mount guides onto the slider rails until the front rack-mount brackets come in contact with the front rack-mount rails.	4	Mounting rails on rack or cabinet posts.

- b) Align the two rear rack-mount guides on either side of the switch with the slider rails installed in the rack. Slide the rack-mount guides onto the slider rails, and then gently slide the switch all the way into the rack until the front rack-mount brackets come in contact with two rack or cabinet posts.
- c) Holding the chassis level, insert two screws (12-24 or 10-32, depending on the rack type) in each of the two front rack-mount brackets (using a total of four screws) and into the cage nuts or threaded holes in the vertical rack-mounting rails (see the following figure).

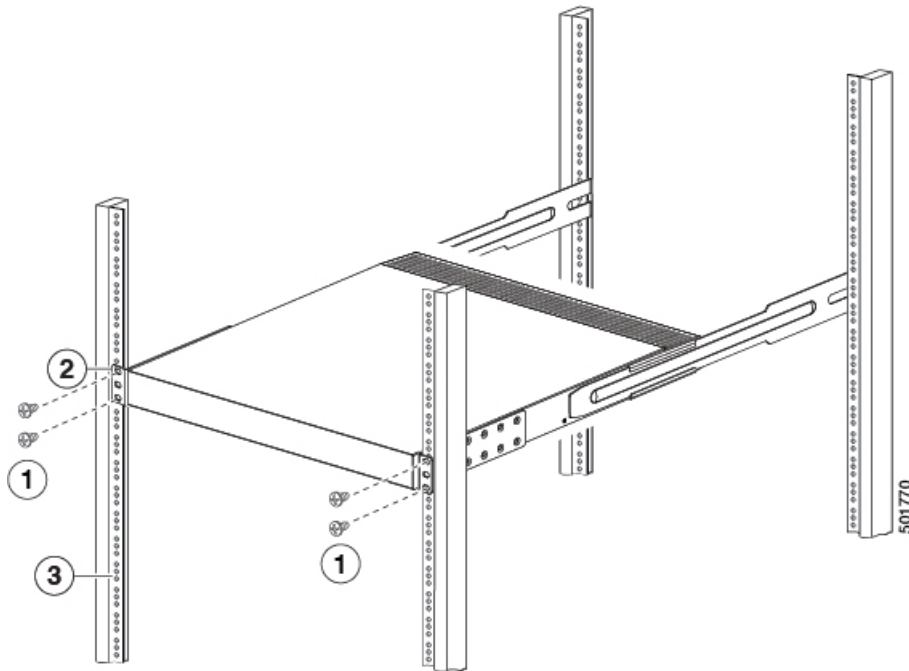

1	Fasten the chassis to the front of the rack with two 12-24 or 10-32 screws on each side.	3	Mounting rails on rack or cabinet posts.
2	Front-mount bracket.		

d) Tighten the 10-32 screws to 20 in-lb (2.26 N·m) or tighten the 12-24 screws to 30 in-lb (3.39 N·m).

Step 6 If you attached a grounding wire to the chassis grounding pad, connect the other end of the wire to the facility ground.

Installing the Switch into a Two-post Rack

To install the switch, you must attach mounting brackets to the switch and secure the switch to the rack. Installation in racks other than 19-inch racks requires a bracket kit not included with the switch.

The following figure shows the standard 19-inch mounting brackets.

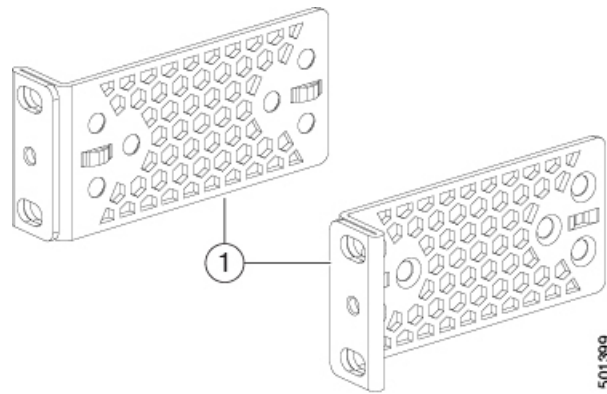

1	Standard mounting bracket for a 19-inch, two-post rack	
---	--	--

Step 1

Install the brackets to the switch.

- a) Determine which end of the chassis is to be located in the cold aisle as follows:
 - If the switch has port-side intake modules (fan modules with burgundy coloring), position the switch so that its ports will be in the cold aisle.
 - If the switch has port-side exhaust modules (fan modules with blue coloring), position the switch so that its fan and power supply modules will be in the cold aisle.
- b) Position the bracket so that four of its screw holes are aligned to the screw holes on the side of the chassis as shown in the following figure.

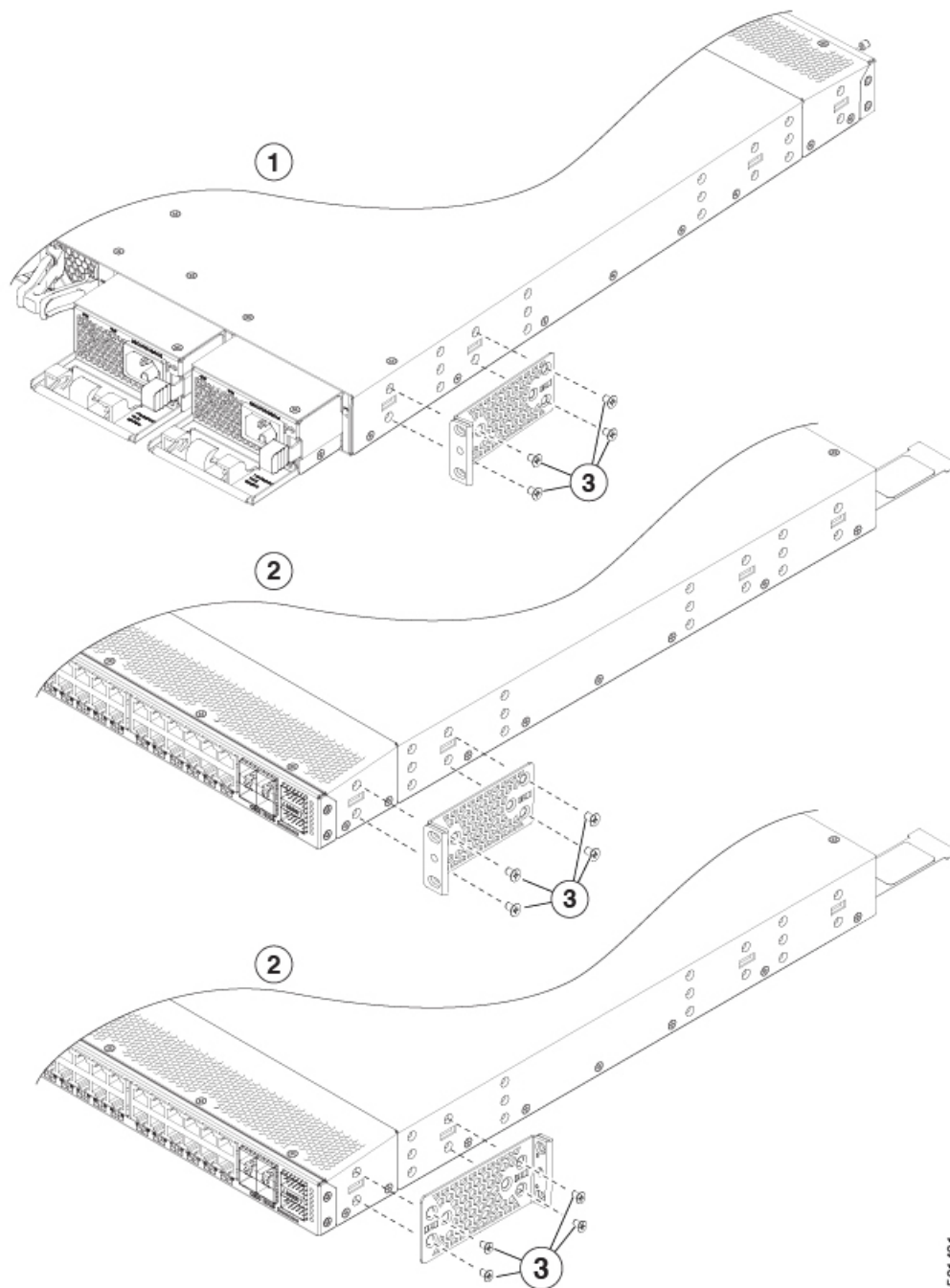

501401

1	Rear-mounting position	3	Number-8 Phillips flat-head screws (4 each bracket)
2	Front-mounting position		

- c) Secure the bracket to the chassis using four Number-8 Phillips flat-head screws and tighten each screw to 12 in-lb (1.36 N·m) of torque.
- d) Repeat previous step for the other front rack-mount bracket on the other side of the switch and be sure to position that bracket the same distance from the front of the switch.

- Step 2** Install the chassis into the rack.
- a) Use two M4 screws to attach the brackets to the rack.

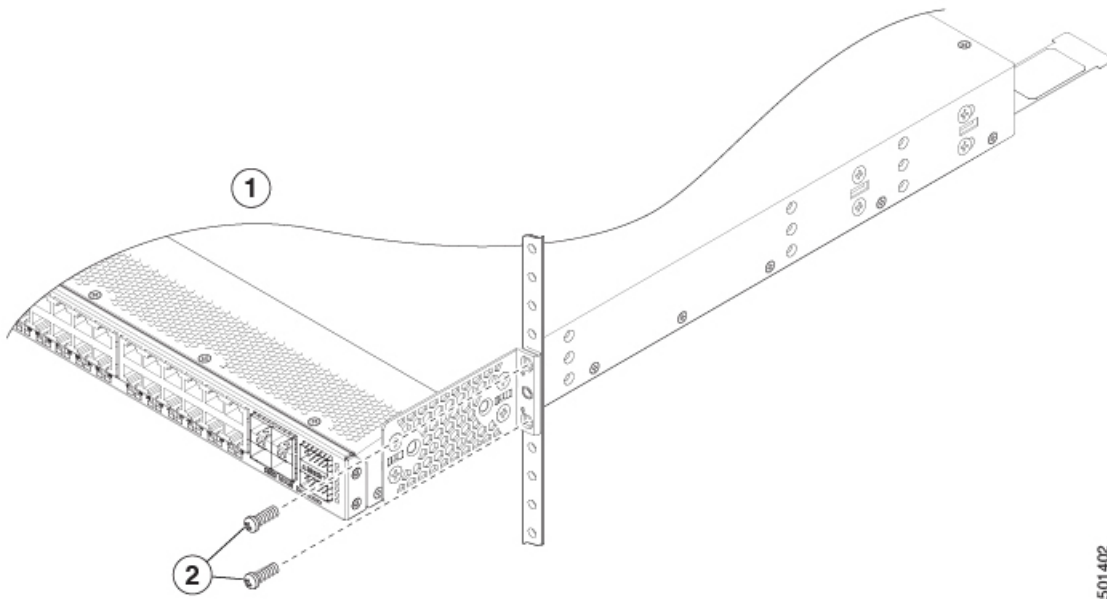

501402

1	Front-mounting position	2	M4 screws (2 each side)
---	-------------------------	---	-------------------------

Grounding the Chassis

The switch chassis is automatically grounded when you properly install the switch in a grounded rack with metal-to-metal connections between the switch and rack.



Note An electrical conducting path shall exist between the product chassis and the metal surface of the enclosure or rack in which it is mounted or to a grounding conductor. Electrical continuity shall be provided by using thread-forming type mounting screws that remove any paint or non-conductive coatings and establish a metal-to-metal contact. Any paint or other non-conductive coatings shall be removed on the surfaces between the mounting hardware and the enclosure or rack. The surfaces shall be cleaned and an antioxidant applied before installation.

You can also ground the chassis, which is required if the rack is not grounded, by attaching a customer-supplied grounding cable. Attach the cable to the chassis grounding pad and the facility ground.



Warning **Statement 1024**—Ground Conductor

This equipment must be grounded. To reduce the risk of electric shock, never defeat the ground conductor or operate the equipment in the absence of a suitably installed ground conductor. Contact the appropriate electrical inspection authority or an electrician if you are uncertain that suitable grounding is available.



Warning Statement 1046—Installing or Replacing the Unit

To reduce risk of electric shock, when installing or replacing the unit, the ground connection must always be made first and disconnected last.

Before you begin

Before you can ground the chassis, you must have a connection to the earth ground for the data center building.

Step 1 Use a wire-stripping tool to remove approximately 0.75 inch (19 mm) of the covering from the end of the grounding wire. We recommend 6-AWG wire for the U.S. installations.

Step 2 Insert the stripped end of the grounding wire into the open end of the grounding lug. Use a crimping tool to crimp the lug to the wire, see the following figure. Verify that the ground wire is securely attached to the grounding lug by attempting to pull the wire out of the crimped lug.

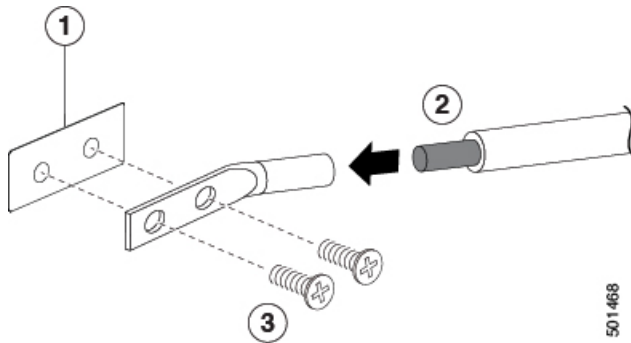

1	Chassis grounding pad	3	2 M4 screws are used to secure the grounding lug to the chassis
2	Grounding cable, with 0.75 in. (19 mm) of insulation that is stripped from one end, which is inserted into the grounding lug and crimped in place		

Step 3 Secure the grounding lug to the chassis grounding pad with two M4 screws, see the previous figure. Tighten the screws to 11 to 15 in-lb (1.24 to 1.69 N·m) of torque.

Step 4 Prepare the other end of the grounding wire and connect it to the facility ground.

Starting the Switch

You start the switch by connecting it to its dedicated power source. If you need $n+1$ redundancy, you must connect each of the power supplies to one or two power sources. If you need $n+n$ redundancy, you must connect each power supply in a switch to a different power source.



Note This equipment is designed to boot up in less than 30 minutes, dependent on its neighboring devices being fully up and running.

Before you begin

- The switch must be installed and secured to a rack or cabinet.
- The switch must be adequately grounded.
- The rack must be close enough to the dedicated power source so that you can connect the switch to the power source by using a designated power cables.
- You have the designated power cables for the power supplies that you are connecting to the dedicated power sources.



Note Depending on the outlet receptacle on your AC power distribution unit, you might need an optional jumper power cord to connect the switch to your outlet receptacle.

- The switch is not connected to the network (this includes any management or interface connections).
- The fan and power supply modules are fully secured in their chassis slots.

Step 1 For each AC power supply, do the following:

- a) Using the recommended AC power cable for your country or region, connect one end to the AC power supply.
- b) Connect the other end of the power cable to the AC power source.

Step 2 For each HVAC/HVDC power supply, connect it to a power source as follows:

- a) Using the recommended high voltage power cable for your country or region, connect the Anderson Power Saf-D-Grid connector on the power cable to the power receptacle on the power supply. Make sure that the connector clicks when fully pushed into the receptacle.
- b) Connect the other end of the power cable to a power source.
 - When connecting to an HVAC power source, insert the C14 or LS-25 plug in a receptacle for the HVAC power source.
 - When connecting to an HVDC power source, do the following:
 1. Verify that the power is turned off at a circuit breaker for the power source terminals.
 2. Remove the nuts from each of the terminal posts for the power supply.

3. Place the power cable negative-wire terminal ring on the negative terminal for the power source and secure them with a terminal nut.
4. Place the power cable positive-wire terminal ring on the positive terminal for the power source and secure them with a terminal nut.
5. Place the power cable ground-wire terminal ring on the ground terminal for the power source and secure them with a terminal nut.
6. If there is a safety cover for the power source terminals, place and secure it over the terminals to avoid an electrical shock hazard.
7. Turn on the power at the power source circuit breaker.

Step 3 For each DC power supply, do the following:

- a) Turn off the circuit breaker for the power source to avoid an electrical shock hazard.
- b) Verify that the power cable wires from the power source are connected to a connector block.
- c) Insert the connector block into the receptacle on the power supply. Make sure that the connector block clicks when fully inserted in the receptacle and does not pull out.
- d) If there is a safety cover for the terminals, place and secure it over the terminals to avoid an electrical shock hazard.
- e) Turn on the power at the circuit breaker for the DC power source.

Step 4 Verify that the power supply LED is on and green.

Step 5 Listen for the fans; they should begin operating when the power supply is powered.

Step 6 After the switch boots, verify that the following LEDs are lit:

- On the fan modules, the Status (STA or STS) LED is green.
If a fan module Status LED is not green, try reinstalling the fan module.
- After initialization, the switch chassis Status (labeled as STA or STS) LED is green.

Step 7 Verify that the system software has booted and the switch has initialized without error messages.

A setup utility automatically launches the first time that you access the switch and guides you through the basic configuration. For instructions on how to configure the switch and check module connectivity, see the appropriate Cisco Nexus 9000 Series configuration guide.



CHAPTER 4

Connecting the Switch to the ACI Fabric

- [ACI Fabric Topology, on page 31](#)
- [Preparing to Connect to Other Devices, on page 32](#)
- [Connecting Leaf Switches to APICs, on page 33](#)
- [Connecting Leaf Switches to Spine Switches, on page 35](#)
- [Installing a Gigabit Ethernet module \(GEM\), on page 36](#)
- [Virtual Port Channel Migration - Migration of Nodes from a First-Generation Switch to a Second-Generation Switch, on page 36](#)
- [Setting Up an Optional Console Interface, on page 37](#)
- [Setting Up an Optional Management Connection, on page 38](#)
- [Optic Transceiver Removal Using the Optics Extraction Tool , on page 39](#)
- [Maintaining Transceivers and Optical Cables, on page 40](#)

ACI Fabric Topology

The ACI fabric topology includes the following major components:

- Application Centric Infrastructure Controller (APIC) appliance (cluster of APICs)
- Leaf switches (for switch compatibility, please see the [data sheets](#)).
- Spine switches (for switch compatibility, please see the [data sheets](#)).

For additional information, please see the [Cisco APIC Installation, Upgrade, and Downgrade Guide](#).



Note To prevent sub-optimal forwarding between endpoints, connect every leaf switch in the fabric to every spine switch in the same fabric.

As shown in the following figure, each APIC is connected to one or two leaf switches and each leaf switch should be connected to every spine switch in the same fabric.

Figure 1: Connections Between APIC Clusters, Leaf Nodes, and Spine Nodes

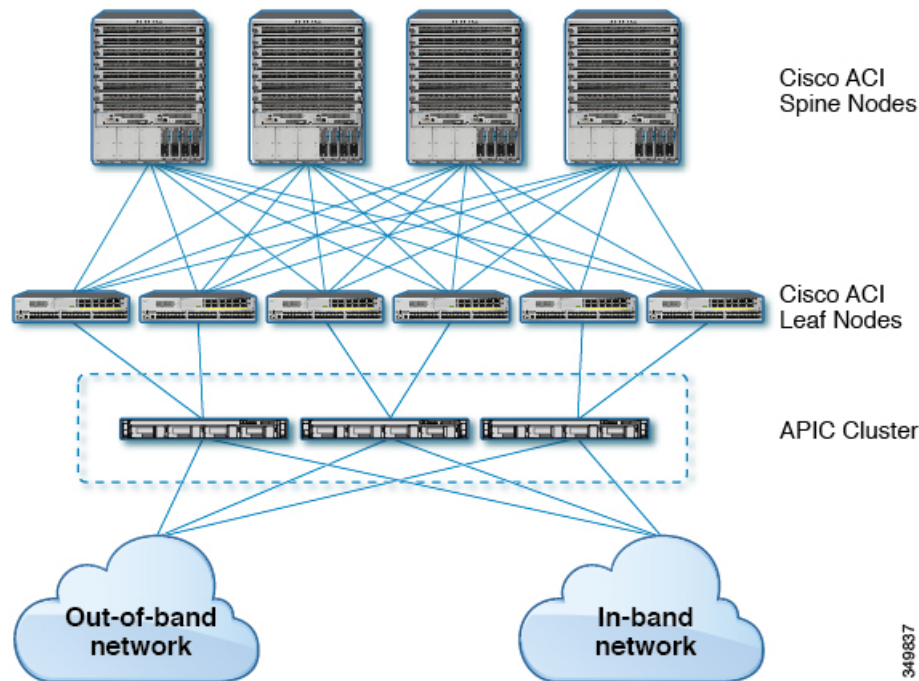

Preparing to Connect to Other Devices

When preparing to connect the fabric devices, consider the following for each type of interface, and gather all of the required equipment before making the connections:

- Cabling type required for each interface type
- Distance limitations for each signal type
- Additional interface equipment required



Note When running power and data cables in overhead or subfloor cable trays, we strongly recommend that you locate power cables and other potential noise sources as far away as practical from network cabling that terminates on Cisco equipment. In situations where long parallel cable runs cannot be separated by at least 3.3 feet (1 meter), we recommend that you shield any potential noise sources by housing them in a grounded metallic conduit.

The optical transceivers that are not already assembled to their cables come separate from their cables. To prevent these transceivers and their cables from being damaged, we recommend that you keep the transceivers disconnected from their cables when installing them in ports and then insert the optical cable into the transceiver. When removing transceivers from ports, remove their cables before removing the transceivers.

To maximize the effectiveness and life of your transceivers and optical cables, do the following:

- Wear an ESD-preventative wrist strap that is connected to an earth ground whenever handling transceivers. The switch is typically grounded when you install transceivers and provides an ESD port to which you

can connect your wrist strap. If you cannot find an ESD port, connect the wrist strap to an earth ground (such as the grounding connection for the chassis).

- Do not remove or insert a transceiver more often than necessary. Repeated removals and insertions can shorten its useful life.
- Keep the transceivers and fiber-optic cables clean and dust free to maintain high signal accuracy and to prevent damage to the connectors. Attenuation (loss of light) increases with contamination and should be kept below 0.35 dB.
 - Clean these parts before installing them to prevent dust from scratching the fiber-optic cable ends.
 - Clean the connectors regularly; the required frequency of cleaning depends upon the environment. In addition, clean connectors if they are exposed to dust or accidentally touched. Both wet and dry cleaning techniques can be effective; refer to your site's fiber-optic connection cleaning procedures.
 - Do not touch the ends of connectors. Touching the ends can leave fingerprints and cause other contamination.
- Inspect routinely for dust and damage. If you suspect damage, clean and then inspect fiber ends under a microscope to determine if damage has occurred.

Connecting Leaf Switches to APICs

You must downlink one or two (recommended for redundancy) Cisco Nexus 9300 platform ACI-mode leaf switches to each Application Policy Infrastructure Controller (APIC) in your ACI fabric. The type of virtual interface card (VIC) installed on the APIC determines the types of interface cables that you can use to connect the leaf switches to the APICs.

- The **VIC 1225T** module supports copper connectors, copper cables, and switches with copper downlink ports (such as: Cisco Nexus 93108TC-FX switch).
- The **VIC 1225** module supports optical transceivers, optical cables, and switches with optical downlink ports (such as: Cisco Nexus 93600CD-GX switch).
- The **VIC 1455** module supports optical transceivers, optical cables, and switches with optical downlink ports (such as: Cisco Nexus 93600CD-GX switch).



Note Breakout ports cannot be used for Cisco APIC connectivity.

Before you begin

The APIC and leaf switches in the fabric must be fully installed in their racks and grounded.

Step 1

Connect an interface cable to one of the two to four ports on the virtual interface card (VIC) installed on the APIC. If the cable is not already assembled to its transceivers, insert the transceiver into the VIC port and then connect the optical interface cable to the transceiver.

- For a **VIC 1225T** 10GBASE-T copper module, use 10GBASE-T cables with RJ-45 connectors.

- For a **VIC 1225** optical module, use one of the following sets of transceivers and cables:
 - Cisco 10GBASE-LR transceivers (SFP-10G-LR) supporting a link length of up to 6.1 miles (10 km)
 - Cisco 10GBASE-SR transceivers (SFP-10G-SR) supporting the following link lengths:
 - Using 2000 MHz MMF (OM3) for up to 984 feet (300 m)
 - Using 4700 MHz MMF (OM4) for up to 1312 feet (400 m)
 - Cisco SFP+ Active Optical Cables (SFP-10G-AOC x M [where $x=1, 3, 5, 7$ for lengths in meters])
 - Cisco SFP+ Twinax Cables (SFP-H10GB-CU x M [where $x=7$ for lengths in meters])
- For a **VIC 1455** SFP28 module, 10-Gigabit only, use one of the following sets of transceivers and cables:
 - Cisco 10GBASE-LR transceivers (SFP-10G-LR) supporting a link length of up to 6.1 miles (10 km)
 - Cisco 10GBASE-SR transceivers (SFP-10G-SR) supporting the following link lengths:
 - Using 2000 MHz MMF (OM3) for up to 984 feet (300 m)
 - Using 4700 MHz MMF (OM4) for up to 1312 feet (400 m)
 - Cisco SFP+ Active Optical Cables (SFP-10G-AOC x M [where $x=1, 2, 3, 5, 7, \text{ or } 10$ for lengths in meters])
 - Cisco SFP+ Twinax Cables (SFP-H10GB-CU x M [where $x=1, 2, 3, 5, 7, \text{ or } 10$ for lengths in meters])

Note The VIC 1455 has 4 ports, port-1, port-2, port-3, and port-4 from left to right.

- All ports must have the same speed, either 10-Gigabit or 25-Gigabit.
- Port-1 and port-2 is one pair, corresponding to eth2-1 on APIC and port-3 and port-4 is another pair, corresponding to eth2-2 on APIC. Only one connection is allowed for each pair. For example, you can connect one cable to either port-1 or port-2, and connect another cable to either port-3 or port-4 (**please do not connect two cables on any pair**).

To determine which transceivers, adapters, and cables support this switch, see the [Cisco Transceiver Modules Compatibility Information](#) document.

To see the transceiver specifications and installation information, see [Transceiver Module Installation Guides](#).

Step 2 Connect the other end of the interface cable to a downlink port on a leaf switch.

- For a Cisco 10GBASE-LR or -SR transceiver and cable, insert the transceiver into a downlink optical port on a leaf switch before connecting the cable to the transceiver.
- For Cisco SFP+ Active Optical Cables, insert the transceiver on the cable into a downlink optical port on a leaf switch.
- For a 10GBASE-T copper cable, insert the RJ-45 connector on the cable into a downlink BASE-T port on a leaf switch.

Note To determine which transceivers, adapters, and cables support this switch, see the [Cisco Transceiver Modules Compatibility Information](#) document.

Connecting Leaf Switches to Spine Switches

For optimal forwarding between endpoints, you must connect each leaf switch to every spine switch in the same ACI fabric.

To determine which transceivers, adapters, and cables support this switch, see the [Cisco Transceiver Modules Compatibility Information](#) document.

To see the transceiver specifications and installation information, see [Transceiver Module Installation Guides](#).



Warning **Statement 1055**—Class 1/1M Laser

Invisible laser radiation is present. Do not expose to users of telescopic optics. This applies to Class 1/1M laser products.



Warning **Statement 1056**—Unterminated Fiber Cable

Invisible laser radiation may be emitted from the end of the unterminated fiber cable or connector. Do not view directly with optical instruments. Viewing the laser output with certain optical instruments, for example, eye loupes, magnifiers, and microscopes, within a distance of 100 mm, may pose an eye hazard.

Before you begin

- The leaf and spine switches in the fabric (such as: N9k-C9364C, N9K-C9332C, N9K-C9316D-GX, and N9K-C9332D-GX2B) must be fully installed in their racks and grounded.
- If there are modular switches in the fabric, their ACI-mode line cards must already be installed. The line cards can be of the following types:
 - 32-port 100-Gigabit (such as: N9K-X9732C-EX)
 - 36-port 100-Gigabit (such as: N9K-X9736C-FX)
 - 16-port 400-Gigabit (such as: N9K-X9716D-GX)



Note You cannot include NX-OS line cards in the same chassis when running in ACI mode.



Note Multiple uplinks from a leaf switch to a spine switch is supported. A symmetrical topology is recommended so that all devices have equal access to resources.

-
- Step 1** For the transceivers with removable cables, make sure that the transceivers are separated from their interface cables.
 - Step 2** Insert the appropriate transceiver into an active uplink port on the leaf switch.
 - Step 3** Insert the same type of transceiver in the spine switch port on the line card.
 - Step 4** For transceivers with removable cables, insert the interface cable into the open end of each of those transceivers.
 - Step 5** Repeat Steps 1 through 4 for each spine switch in the ACI fabric.
The leaf switch is connected to each spine switch in the ACI fabric.
 - Step 6** Repeat Steps 1 through 5 for each leaf switch in the ACI fabric.
Each leaf switch in the ACI fabric is connected to each spine switch in the network,
-

The fabric automatically implements Equal Cost Multi-Pathing (ECMP) and enables all links. You do not need to configure the links.

Installing a Gigabit Ethernet module (GEM)

- Step 1** Clear the switch's current configuration by using the `setup-clean-config` command.
 - Step 2** Power off the switch by disconnecting the power.
 - Step 3** Replace the current GEM card with the new GEM card.
 - Step 4** Power on the switch.
-

Virtual Port Channel Migration - Migration of Nodes from a First-Generation Switch to a Second-Generation Switch

Initially the fabric is configured with vPCs between two first-generation switches. Traffic flows are designed so that only these vPCs are used for data traffic. Now that you want to migrate both of the first-generation switches to second-generation switches, the following steps are required.

For this procedure, vPC primary and vPC secondary are first generation switches in vPC pair, sending traffic as described above.

To determine which transceivers, adapters, and cables support this switch, see the [Cisco Transceiver Modules Compatibility Information](#) document.

To see the transceiver specifications and installation information, see [Transceiver Module Installation Guides](#).

Before you begin

You have two first-generation Cisco Nexus 9000 Series switches comprising a virtual port channel (vPC). You are migrating to two second-generation Cisco Nexus 9000 Series switches using the same cables.

First-generation Cisco Nexus 9000 Series switches include those switches that do not contain an EX or an FX in the PID (product identification).

Second-generation Cisco Nexus 9000 Series switches include those switches that have an EX or an FX in the PID.

Move any APIC controllers that are connected to the migrating vPC first-generation switches to any other switches in the fabric and wait for the APIC cluster to become "Fully Fit".

-
- Step 1** From the APIC GUI, perform the **Remove From Controller** operation for vPC secondary. The switch is clean rebooted by the APIC. Wait for about 10 minutes for this operation to finish. This action prompts all traffic to use the other first-generation switch for data traffic. Disconnect the cabling from vPC secondary.
- Step 2** Uninstall the first-generation switch by reversing the order of the steps in the Installing the Switch Chassis section, of the switch specific Hardware Installation Guide.
- Step 3** Install the second-generation switch by following the steps in the Installing the Switch Chassis section, of the switch specific Hardware Installation Guide.
- Step 4** Connect the loose cabling that you removed from the first-generation switch, to the same ports on the second-generation switch.
- Step 5** Now you register the new second-generation switch with the APIC. Register the new node with the same node name and node ID. This switch becomes part of the fabric. Policies are pushed to the new switch and the vPC legs are kept down since there is a mismatch of generation switches. At this point, vPC primary continues to send the data traffic.
- Step 6** From the APIC GUI, perform the **Remove From Controller** operation for vPC primary. This switch is clean rebooted by the APIC.
- Wait for about 10 minutes for this operation to finish. The vPC leg on the second-generation switch, which was kept down earlier comes up. This action prompts all traffic to move to the new second-generation switch. Please note the vPC ports on the new second-generation switch will come up in about 10 to 22 seconds when STP is disabled for the deployed VLANs on the remote devices, and there will be traffic drops in the range of 10 to 40 seconds, depending upon the flows in the fabric. When STP is enabled on the VLANs on the remote devices, the traffic loss will be in the range of 40 to 75 seconds, depending upon the flows in the fabric.
- Step 7** Disconnect the cabling from the other first-generation switch.
- Step 8** Uninstall the first-generation switch, like you did in step 2.
- Step 9** Install the second-generation switch, like you did in step 3.
- Step 10** Connect the loose cabling, like you did in step 4.
- Step 11** Register the new second-generation switch with the APIC. Register the new node with the same node name and node ID. This switch becomes part of the fabric. Policies are pushed to the new switch and the vPC legs comes up and starts passing traffic.
-

Setting Up an Optional Console Interface

You can optionally set up a console interface for performing the initial configuration of the switch. To do this, use the interface cable provided in the accessory kit to connect the switch to your console device. You

can connect the console port on the switch to a modem. If you do not connect it to a modem, make the connection either before powering up the switch or after completing the boot process for the switch.

Before you begin

The console device must support VT100 terminal emulations and asynchronous transmissions.

-
- Step 1** Configure the terminal emulator program to match each of the following default port characteristics:
- 9600 baud
 - 8 data bits
 - 1 stop bit
 - No parity
- Step 2** Insert the RJ-45 connector on the interface cable found in the accessory kit into the RS-232 port on the switch and insert the DB-9 connector on the other end of the cable to the serial port on the console device.
-

What to do next

You can now perform the initial configuration for the switch (see the *Cisco ACI Getting Started Guide*).

Setting Up an Optional Management Connection

You can optionally set up an out-of-band management connection for monitoring and troubleshooting purposes. To do this, depending on your switch, you connect either the RJ-45 management port or the SFP management port on the switch to an external hub, switch, or router.

Before you begin

To prevent an IP address conflict, you must complete the initial configuration for the switch and establish an IP address before you create the management connection.

-
- Step 1** Connect the interface cable to a management port on the switch.
- For the RJ-45 management port, use a copper interface cable with RJ-45 connectors (can be used for shorter connections).
 - For the SFP management port, use an optical interface cable with LH or SX SFP transceivers (can be used for longer connections).
- Note** If you use the management interface, connect only one of the two management ports. The switch does not support your use of two management ports at the same time.
- Step 2** Connect the other end of the cable to an external hub, switch, or router.
-

Optic Transceiver Removal Using the Optics Extraction Tool

You use both ends of the optics extraction tool in this procedure. You use the wide end for releasing the bale latch, and the narrow end for removing the transceiver module.

Before you begin

Ensure that before you handle any switch components, you are wearing a grounded electrostatic discharge (ESD) strap. To ground the strap, attach it directly to earth ground or to a grounded rack or chassis. There must be a metal-to-metal connection to earth ground.

- Step 1** Remove the fiber-optic cables from the transceiver module before removing the transceiver module.
- Step 2** Use the wide side of the optics extraction tool to release the bale latch (see the following image).

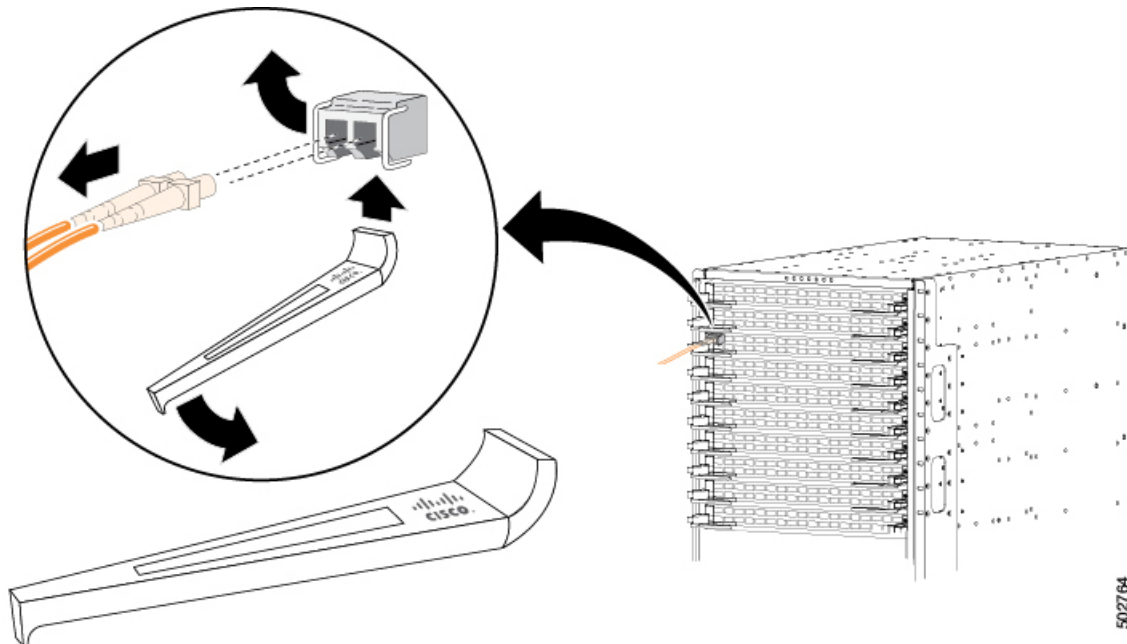

Step 3 Use the narrow end of the optics extraction tool to carefully remove the transceiver module (see the following

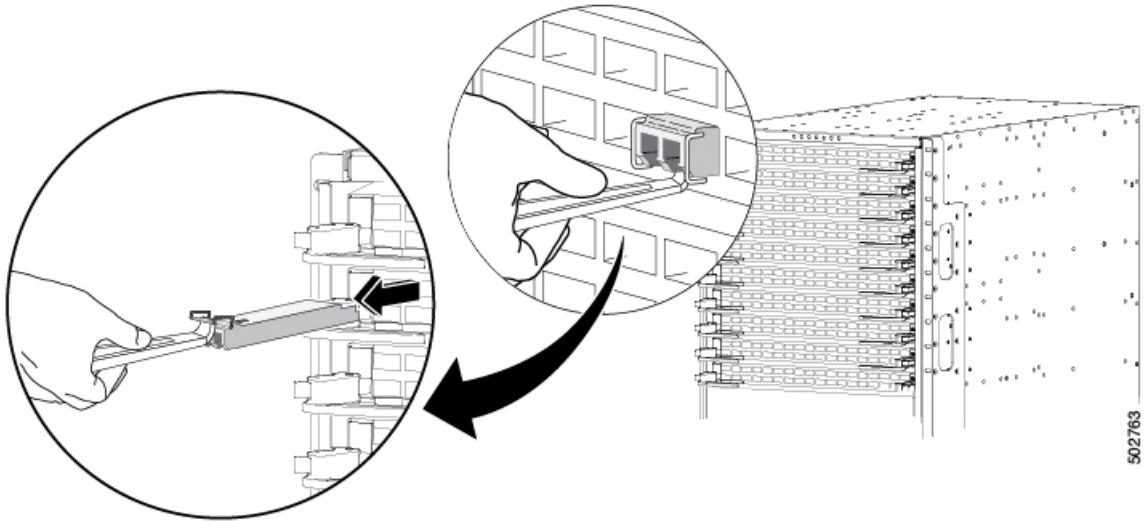

image).

Step 4 Place the transceiver module in an antistatic bag or other protective environment.

Maintaining Transceivers and Optical Cables

Transceivers and fiber-optic cables must be kept clean and dust free to maintain high signal accuracy and prevent damage to the connectors. Contamination increases attenuation (loss of light) and should be below 0.35 dB.

Consider the following maintenance guidelines:

- Transceivers are static sensitive. To prevent ESD damage, wear an ESD-preventative wrist strap that is connected to the grounded chassis.
- Do not remove and insert a transceiver more often than is necessary. Repeated removals and insertions can shorten its useful life.
- Keep all optical connections covered when not in use. Clean them before using to prevent dust from scratching the fiber-optic cable ends.
- Do not touch the ends of connectors. Touching the ends can leave fingerprints and cause other contamination.
- Clean the connectors regularly; the required frequency of cleaning depends upon the environment. In addition, clean connectors if they are exposed to dust or accidentally touched. Both wet and dry cleaning techniques can be effective; refer to the fiber-optic connection cleaning procedures for your site.
- Inspect routinely for dust and damage. If you suspect damage, clean and then inspect fiber ends under a microscope to determine if damage has occurred.



CHAPTER 5

Replacing Components

- [Replacing a Fan Module, on page 41](#)
- [Replacing a Power Supply Module, on page 42](#)

Replacing a Fan Module

You can replace a fan module while the switch is operating so long as you perform the replacement within one minute. If you cannot perform the replacement within one minute, leave the original fan module in the chassis to maintain the designed airflow until you have the replacement fan module on hand and can perform the replacement.



Caution

If you are replacing a module during operations, be sure that the replacement fan module has the correct direction of airflow, which means that it has the same airflow direction as the other modules in the chassis. Also, be sure that the airflow direction takes in air from a cold aisle and exhausts to a hot aisle. Otherwise, the switch can overheat and shutdown.

If you are changing the airflow direction of all the modules in the chassis, you must shutdown the switch before replacing all the fan and power supply modules with modules using the other airflow direction. During operations, all of the modules must have the same direction of airflow.

Removing a Fan Module



Warning

Statement 263—Fan Warning

The fans might still be turning when you remove the fan assembly from the chassis. Keep fingers, screwdrivers, and other objects away from the openings in the fan assembly's housing.

- Step 1** On the fan module that you are removing, press the two sides of the fan module handle next to where it connects to the fan module and pull on the handles enough to unseat it from its connectors.
- Step 2** Holding the handle, pull the module out of the chassis.

Caution Do not touch the electrical connectors on the back side of the module and prevent anything else from coming into contact with and damaging the connectors.

Installing a Fan Module

Before you begin

- A fan slot must be open and ready for the new fan module to be installed.
 - You must have a new fan module on hand and ready to install within one minute of removing the original fan module if the switch is operating.
 - The new fan module must have the same airflow direction as the other fan and power supply modules installed in the switch.
-

- Step 1** Holding the fan module by its handle, align the back of the fan module (the side with the electrical connectors) to the open fan slot in the chassis.
- Step 2** Slide the fan module into the slot until it clicks in place.
- Step 3** Verify that the Status (STS) LED turns on and becomes green.
-

Replacing a Power Supply Module

The switch requires two power supplies for redundancy. With one power supply providing the necessary power for operations, you can replace the other power supply during operations so long as the new power supply has the same airflow direction as the other modules in the chassis.

You can replace a power supply with another supported power supply that has the same power source type and the same wattage rating as the other installed power supply. Additionally, the airflow direction of the power supply must match or conform to the airflow direction of the installed fan modules. For the airflow direction used by the switch, see the coloring of the fan modules.

Replacing an AC Power Supply

You can replace an AC power supply during operations so long as the other power supply provides to the switch.

Before you begin



Note You can determine the airflow direction by looking at the coloring of the latch on each power supply. AC power supplies with burgundy latches have port-side intake airflow direction, and power supplies with blue latches have port-side exhaust airflow direction.

- The replacement power supply must have the same wattage and airflow direction as the power supply being replaced. Do not mix AC, DC, HVAC/HVDC power supplies in the same switch.
- An AC power source must be within reach of the power cable that will be used with the replacement power supply. If you are using $n+n$ power redundancy, there must be a separate power source for each power supply installed in the chassis.
- There must be an earth ground connection to the chassis that you are installing the replacement module. AC power supplies connected to AC power sources are automatically grounded through their power cable.

Step 1

Remove an AC power supply as follows:

- a) Holding the plug for the power cable, pull the plug out from the power receptacle on the power supply and verify that both power supply LEDs are off.
- b) Grasp the power supply handle while pressing the colored release latch towards the power supply handle.
- c) Place your other hand under the power supply to support it while you slide it out of the chassis.

Caution Do not touch the electrical connections on the back side of the module and prevent anything else from coming into contact with and damaging the connectors.

Step 2

Install the replacement power supply as follows:

- a) Holding the replacement power supply with one hand underneath the module and the other hand holding the handle, turn the power supply so that its release latch is on the right side and align the back end of the power supply (the end with the electrical connections) to the open power supply slot before carefully sliding the power supply all the way into the slot until it clicks into place.

Note If the power supply does not fit into the open slot, turn the module over before sliding it carefully into the open slot.

- b) Test the installation by trying to pull the power supply out of the slot without using the release latch.

If the power supply does not move out of place, it is secured in the slot. If the power supply moves, carefully press it all the way into the slot until it clicks in place.

- c) Attach the power cable to the electrical outlet on the front of the power supply.
- d) Make sure that the other end of the power cable is attached to the appropriate power source for the power supply.

Note Depending on the outlet receptacle on your power distribution unit, you might need the optional jumper cable to connect the switch to your outlet receptacle.

- e) Verify that the power supply is operational by making sure that the power supply LED is green.

Replacing a High Voltage (HVAC/HVDC) Power Supply

You can replace an HVACHVDC power supply during operations so long as the other power supply provides power to the switch.

Before you begin

- The replacement power supply must have the same wattage and airflow direction as the power supply being replaced. Do not mix AC, DC, HVAC/HVDC power supplies in the same switch.
- An HVAC/HVDC power source must be within reach of the power cable that will be used with the replacement power supply. If you are using $n+n$ power redundancy, there must be a separate power source for each power supply installed in the chassis.
- There must be an earth ground connection to the chassis in which you are installing the replacement power supply. HVAC/HVDC power supplies connected to AC power sources are automatically grounded by their power cable when connected to the power supply and AC power source. HVAC/HVDC power supplies connected to DC power sources have Saf-D-Grid power cables with three connectors on the power source end--you connect one of those connectors to the earth ground.

Step 1 Remove an HVAC/HVDC power supply as follows:

- a) Turn off the circuit breaker for the power feed to the power supply that you are replacing.
Be sure that the LEDs turn off on the power supply that you are removing.
- b) Remove the power cable from the power supply by pressing the tab on the top of the Anderson Power SAF-D-Grid connector and pull the cable and connector out of the power supply.
- c) Grasp the power supply handle while pressing the colored release latch towards the power supply handle.
- d) Place your other hand under the power supply to support it while you slide it out of the chassis.

Caution Do not touch the electrical connections on the back side of the module and prevent anything else from coming into contact with and damaging the connectors.

Step 2 Install the replacement power supply as follows:

- a) Holding the replacement power supply with one hand underneath the module and the other hand holding the handle, turn the power supply so that its release latch is on the right side and align the back end of the power supply (the end with the electrical connections) to the open power supply slot before carefully sliding the power supply all the way into the slot until it clicks into place.

Note If the power supply does not fit into the open slot, turn the module over before sliding it carefully into the open slot.

- b) Test the installation by trying to pull the power supply out of the slot without using the release latch.
If the power supply does not move out of place, it is secured in the slot. If the power supply moves, carefully press it all the way into the slot until it clicks in place.
- c) Attach the Saf-D-Grid end of the power cable to the electrical outlet on the front of the power supply.
- d) Make sure that the other end of the power cable is attached to the appropriate power source for the power supply.
 - For an HVAC power source, plug the other end of the power cable into the power source.
 - For a HVDC power source, verify that the circuit breaker is turned off and then connect each of the three cable connectors to the appropriate DC and grounding terminals on the power source. If there is a cover plate for the DC terminals, install the plate to prevent accidental contact with the terminals.
- e) If using an HVDC power source, turn on the circuit breaker for the power source.

- f) Verify that the power supply is operational by making sure that the power supply LED is green.

Replacing a DC Power Supply

You can replace an DC power supply during operations so long as the other power supply provides power to the switch.

Before you begin

- The replacement power supply must have the same wattage and airflow direction as the power supply being replaced. Do not mix AC, DC, HVAC/HVDC power supplies in the same switch.



Note You can determine the airflow direction by looking at the coloring of the latch on each power supply. AC power supplies with burgundy latches have port-side intake airflow direction, and power supplies with blue latches have port-side exhaust airflow direction.

- An DC power source must be within reach of the power cables that will be used with the replacement power supply. If you are using $n+n$ power redundancy, there must be a separate power source for each power supply installed in the chassis.
- There must be an earth ground connection to the chassis in which you are installing the replacement power supply. DC power supplies connected to DC power sources have three power cables (two for DC power and one for grounding).
- We recommend 8-AWG wire for DC installation in the U.S.
- All DC power supplies have reverse polarity protection. When you inadvertently connect the input power (+) to the DC PSU's – terminal and the input power – to the DC PSU's (+) terminal, the PSU will not be damaged and will operate fine after the input power feeds are correctly wired.

Step 1

Remove a DC power supply as follows:

- a) Turn off the circuit breaker for the power feed to the power supply that you are replacing.
Be sure that the LEDs turn off on the power supply that you are removing.
- b) Remove the DC power connector block from the power supply by doing the following:
 1. Push the orange plastic button on the top of the connector block inward toward the power supply.
 2. Pull the connector block out of the power supply.
- c) Grasp the power supply handle while pressing the release latch towards the power supply handle.
- d) Place your other hand under the power supply to support it while you slide it out of the chassis.

Caution Do not touch the electrical connections on the back side of the module and prevent anything else from coming into contact with and damaging the connectors.

- Step 2** Install the replacement power supply as follows:
- Holding the replacement power supply with one hand underneath the module and the other hand holding the handle, turn the power supply so that its release latch is on the right side and align the back end of the power supply (the end with the electrical connections) to the open power supply slot before carefully sliding the power supply all the way into the slot until it clicks into place.

Note If the power supply does not fit into the open slot, turn the module over before sliding it carefully into the open slot.
 - Test the installation by trying to pull the power supply out of the slot without using the release latch.

If the power supply does not move out of place, it is secured in the slot. If the power supply moves, carefully press it all the way into the slot until it clicks in place.
 - Attach the power connector block end of the power cable to the electrical outlet on the front of the power supply.
 - Turn on the circuit breaker for the power source.
 - Verify that the power supply is operational by making sure that the power supply LED is green.

Wiring the DC Input Power Source

- Step 1** Using a wire-stripping tool, strip each of the four wires from the DC-input power source to the appropriate length for the terminals.

Warning Statement 1025—

Use copper conductors only.

- Step 2** Using a Panduit crimping tool, crimp the fork-type terminals to the copper conductor, 90C, 12-AWG DC power input wires.

- Step 3** Connect the DC-input power terminals to the terminal blocks. Make sure to match the polarity (negative to negative, positive to positive) when connecting the wires to the terminal blocks. Connect the ground wire to a grounded metal rack or to earth ground if the switch is not in a grounded rack.

Figure 2: DC Source A Isolated from Source B with No Common Ground

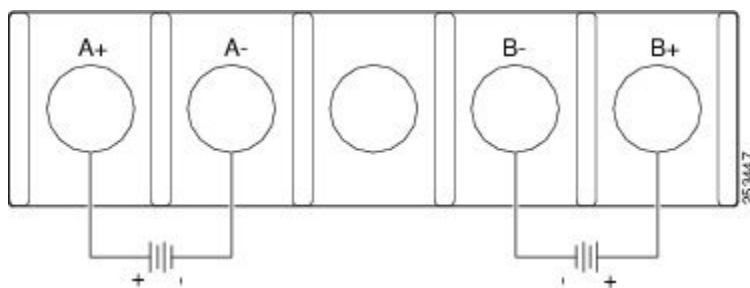
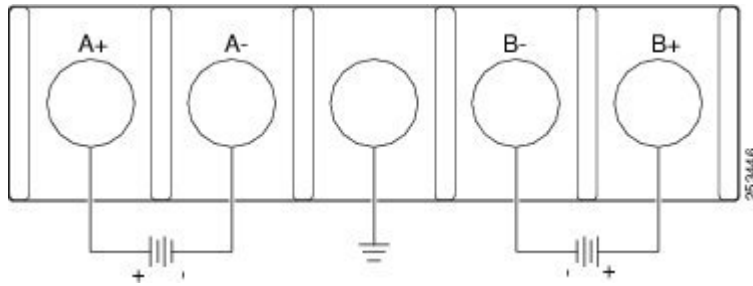

Figure 3: DC Source A and Source B Connections with Common Ground



- Step 4** Torque all terminal block screws to 11 lbf-in.
 - Step 5** Replace the terminal block safety cover.
 - Step 6** Move the DC power source circuit-breakers to the ON position.
 - Step 7** Confirm that the power supply DC OK and PS OK LEDs are green.
-



APPENDIX **A**

Rack Specifications

- [Overview of Racks, on page 49](#)
- [General Requirements for Cabinets and Racks, on page 49](#)
- [Requirements Specific to Standard Open Racks, on page 50](#)
- [Requirements Specific to Perforated Cabinets, on page 50](#)
- [Cable Management Guidelines, on page 51](#)

Overview of Racks

You can install the switch in the following types of cabinets and racks, assuming an external ambient air temperature range of 0 to 104°F (0 to 40°C):

- Standard perforated cabinets
- Solid-walled cabinets with a roof fan tray (bottom to top cooling)
- Standard open racks



Note If you are selecting an enclosed cabinet, we recommend one of the thermally validated types, either standard perforated or solid-walled with a fan tray.



Note We do not recommend that you use racks that have obstructions (such as power strips), because the obstructions could impair access to field-replaceable units (FRUs).

General Requirements for Cabinets and Racks

The cabinet or rack must also meet the following requirements:

- Standard 19-inch (48.3 cm) (two- or four-post EIA cabinet or rack, with mounting rails that conform to English universal hole spacing per section 1 of ANSI/EIA-310-D-1992). For more information, see [Requirements Specific to Perforated Cabinets, on page 50](#).

- The minimum vertical rack space requirement per chassis is:
 - For a one RU (rack unit) switch, 1.75 inches (4.4 cm)
 - For a one and a half RU (rack unit) switch, 2.63 (6.68 cm)
 - For a two RU (rack unit) switch, 3.5 inches (8.8 cm)
 - For a three RU (rack unit) switch, 5.25 inches (13.3 cm)
- The width between the rack-mounting rails must be at least 17.75 inches (45.0 cm) if the rear of the device is not attached to the rack. For four-post EIA racks, this measurement is the distance between the two front rails.

Four-post EIA cabinets (perforated or solid-walled) must meet the following requirements:

- The minimum spacing for the bend radius for fiber-optic cables should have the front-mounting rails of the cabinet offset from the front door by a minimum of 3 inches (7.6 cm).
- The distance between the outside face of the front mounting rail and the outside face of the back mounting rail should be 23.0 to 30.0 inches (58.4 to 76.2 cm) to allow for rear-bracket installation.

For the specific rack dimension information for each possible rack-mount, see [Installation Options with Rack-Mount Kits](#), on page 14.

Requirements Specific to Standard Open Racks

If you are mounting the chassis in an open rack (no side panels or doors), ensure that the rack meets the following requirements:

- The minimum vertical rack space per chassis must be equal to the rack unit (RU) of the chassis. One rack unit is equal to 1.75 inches (4.4 cm).
- The distance between the chassis air vents and any walls should be 2.5 inches (6.4 cm).

Requirements Specific to Perforated Cabinets

A perforated cabinet has perforations in its front and rear doors and side walls. Perforated cabinets must meet the following requirements:

- The front and rear doors must have at least a 60 percent open area perforation pattern, with at least 15 square inches (96.8 square cm) of open area per rack unit of door height.
- The roof should be perforated with at least a 20 percent open area.
- The cabinet floor should be open or perforated to enhance cooling.

The Cisco R Series rack conforms to these requirements.

Cable Management Guidelines

To help with cable management, you might want to allow additional space in the rack above and below the chassis to make it easier to route all of the fiber optic or copper cables through the rack.



APPENDIX **B**

System Specifications

- [Environmental Specifications, on page 53](#)
- [Switch Dimensions, on page 53](#)
- [Switch and Module Weights and Quantities, on page 54](#)
- [Transceiver and Cable Specifications, on page 54](#)
- [Switch Power Input Requirements, on page 54](#)
- [Power Specifications, on page 55](#)
- [Power Cable Specifications, on page 57](#)
- [Regulatory Standards Compliance Specifications, on page 58](#)

Environmental Specifications

Environment		Specification
Temperature	Ambient operating temperature	32 to 104°F (0 to 40°C)
	Ambient nonoperating	–40 to 158°F (–40 to 70°C)
Relative humidity	Nonoperating	5 to 85%
Altitude	Operating	0 to 13,123 feet (0 to 4,000 meters)

Switch Dimensions

Switch	Width	Depth	Height
Cisco Nexus 9348GC-FXP	17.3 inches (43.9 cm)	With AC power supplies 19.7 inches (49.9 cm). With DC power supplies 21.0 inches (53.34 cm).	1.72 inches (4.4 cm) (1 RU)

Switch and Module Weights and Quantities

Component	Weight per Unit	Quantity
Cisco Nexus 9348GC-FXP Chassis (N9K-C9348GC-FXP)	14.2 lb (6.44 kg)	1
Fan Module – Port-side exhaust (blue) (NXA-FAN-30CFM-F) – Port-side intake (burgundy) (NXA-FAN-30CFM-B)	— 0.26 lb (0.12 kg)	3
Power Supply module – 350-W AC port-side exhaust (blue) (NXA-PAC-350W-PE) – 350-W AC port-side intake (burgundy) (NXA-PAC-350W-PI) – 350-W HVAC/HVDC port-side exhaust (blue) (NXA-PHV-350W-PE) – 350-W HVAC/HVDC port-side intake (burgundy) (NXA-PHV-350W-PI) – 440-W DC port-side exhaust (blue) (NXA-PDC-440W-PE) – 440-W DC port-side intake (burgundy) (NXA-PDC-440W-PI)	— 2.64 lb (1.2 kg)	2 (1 for operations and 1 for redundancy)

Transceiver and Cable Specifications

To determine which transceivers, adapters, and cables are supported by this switch, see <https://www.cisco.com/c/en/us/support/interfaces-modules/transceiver-modules/products-device-support-tables-list.html>.

To see the transceiver specifications and installation information, see <https://www.cisco.com/c/en/us/support/interfaces-modules/transceiver-modules/products-device-support-tables-list.html>.

Switch Power Input Requirements

The following table lists the typical amount of power that the switch consumes. It also lists the maximum amount of power that you must provision for the switch and power supply for peak conditions.



Note Some power supplies have capabilities that are greater than the maximum power requirements for a switch. To determine the power consumption characteristics for the switch, use the typical and maximum requirements that are listed in the following table.

Switch	Typical Power Consumption (AC or DC)	Maximum Power Consumption (AC or DC)	Heat Dissipation Requirement
Cisco Nexus 9348GC-FXP	178 W	287 W	979.284 BTUs per hour

Power Specifications

Power specifications include the specifications for each type of power supply module.

350-W AC Power Supply Specifications

These specifications apply to the following power supplies:

- NXA-PAC-350W-PE
- NXA-PAC-350W-PI

Characteristic	Specification
AC input voltage	Nominal range: 100 and 240 VAC (Range: 90-132 VAC, 180-264 VAC)
AC input frequency	Nominal range: 50 to 60 Hz (Range: 47-63 Hz)
Maximum AC input current	7.6 A at 100 VAC 3.65 A at 208 VAC
Maximum input volt-amperes	760 A at 100 VAC
Maximum output power per power supply	350 W
Maximum inrush current	33 A (sub-cycle duration)
Maximum hold-up time	12 ms at 350 W
Power supply output voltage	12 VDC
Power supply standby voltage	12 VDC
Efficiency rating	Climate Savers Platinum Efficiency (80Plus Platinum certified)
Form factor	RSP1

350-W PHV Power Supply Specifications

These specifications apply to the following power supplies:

- NXA-PHV-350W-PE
- NXA-PHV-350W-PI

Characteristic	Specification
Input voltage	192 to 400 VDC 90 to 305 VAC
Input frequency	Nominal range: 50 to 60 Hz (Range: 47-63 Hz)
Maximum output power per power supply	350 W
Power supply output voltage	12 V
Power supply standby voltage	12 V
Efficiency rating	Climate Savers Platinum Efficiency (80Plus Platinum certified)
Form factor	RSP1

440-W DC Power Supply Specifications

These specifications apply to the following power supplies:

- NXA-PDC-440W-PE
- NXA-PDC-440W-PI

Characteristic	Specification
Maximum output power	440 W
Input current	16 -8 A
DC input voltage	-36 to -72 VDC
Output ratings	-56 V@7.86 A
Voltage range domestic	-36 VDC (minimum), -48 VDC (nominal), -72 VDC (maximum)
Voltage range international	-36 VDC (minimum), -48 VDC (nominal), -72 VDC (maximum)
Total input BTU ¹	1841 BTUs per hour, 540 W
Total output BTU ²	1502 BTUs per hour, 440 W

Characteristic	Specification
Branch circuit protection	20 A

- ¹ The total input and total output BTU ratings refer to input power to the power supply and output power to the switch. The BTU ratings are based on -36 VDC.
- ² The total input and total output BTU ratings refer to input power to the power supply and output power to the switch. The BTU ratings are based on -36 VDC.

Power Cable Specifications

The following sections specify the power cables that you can order and use with this switch.

Power Cable Specifications for AC Power Supplies

Locale	Power Cord Part Number	Cord Set Description
	CAB-C13-C14-2M	Power Cord Jumper, C13-C14 Connectors, 6.6 feet (2.0 m)
	CAB-C13-CBN	Cabinet jumper power cord, 250 VAC, 10 A, C14-C13 connectors, 2.3 feet (0.7 m)
Argentina	CAB-250V-10A-AR	250 V, 10 A, 8.2 feet (2.5 m)
Australia	CAB-9K10A-AU	250 VAC, 10 A, 3112 plug, 8.2 feet (2.5 m)
Brazil	CAB-250V-10A-BR	250 V, 10 A, 6.9 feet (2.1 m)
European Union	CAB-9K10A-EU	250 VAC, 10 A, CEE 7/7 plug, 8.2 feet (2.5 m)
India	CAB-IND-10A	10 A, 8.2 feet (2.5 m)
India	CAB-C13-C14-2M-IN	Power Cord Jumper, C13-C14 Connectors, 6.6 feet (2.0 m)
India	CAB-C13-C14-3M-IN	Power Cord Jumper, C13-C14 Connectors, 9.8 feet (3.0 m)
Israel	CAB-250V-10A-IS	250 V, 10 A, 8.2 feet (2.5 m)
Italy	CAB-9K10A-IT	250 VAC, 10 A, CEI 23-16/VII plug, 8.2 feet (2.5 m)
Japan	CAB-C13-C14-2M-JP	Power Cord Jumper, C13-C14 Connectors, 6.6 feet (2.0 m)
North America	CAB-9K12A-NA	125 VAC, 13 A, NEMA 5-15 plug, 8.2 feet (2.5 m)

Locale	Power Cord Part Number	Cord Set Description
North America	CAB-AC-L620-C13	NEMA L6-20-C13, 6.6 feet (2.0 m)
North America	CAB-N5K6A-NA	200/240V, 6A, 8.2 feet (2.5 m)
Peoples Republic of China	CAB-250V-10A-CN	250 V, 10 A, 8.2 feet (2.5 m)
South Africa	CAB-250V-10A-ID	250 V, 10 A, 8.2 feet (2.5 m)
Switzerland	CAB-9K10A-SW	250 VAC, 10 A, MP232 plug, 8.2 feet (2.5 m)
United Kingdom	CAB-9K10A-UK	250 VAC, 10 A, BS1363 plug (13 A fuse), 8.2 (2.5 m)
All except Argentina, Brazil, and Japan	NO-POWER-CORD	No power cord included with switch

DC Power Cable Specifications

Part Number	Description	Photo
NXA-PDC-440W-PE/PI	The 440W DC power supply (NXA-PDC-440W-PE/PI) is shipped with wiring instructions along with these parts: LUG,FAST,UNIN,#8AWG,RED; LUG,FORK,INSL,16-14G,#6,NY,BLUwNARROW TONGUE; LUG,RING,16-14AWG,#6	

Regulatory Standards Compliance Specifications

The following table lists the regulatory standards compliance for the switch.

Table 2: Regulatory Standards Compliance: Safety and EMC

Specification	Description
Regulatory compliance	Products should comply with CE Markings according to directives 2004/108/EC and 2006/95/EC.

Specification	Description
Safety	<ul style="list-style-type: none"> • CAN/CSA-C22.2 No. 60950-1 Second Edition • EN 60950-1 Second Edition • IEC 60950-1 Second Edition • IEC 623681 • AS/NZS 60950-1 • GB4943
EMC: Emissions	<ul style="list-style-type: none"> • 47CFR Part 15 (CFR 47) Class A • AS/NZS CISPR22 Class A • CISPR22 Class A • EN55022 Class A • ICES003 Class A • VCCI Class A • EN61000-3-2 • EN61000-3-3 • KN22 Class A • CNS13438 Class A
EMC: Immunity	<ul style="list-style-type: none"> • EN55024 • CISPR24 • EN300386 • KN 61000-4 series
RoHS	The product is RoH-6 compliant with exceptions for leaded-ball grid-array (BGA) balls and lead press-fit connectors.



APPENDIX C

LEDs

- [Switch Chassis LEDs, on page 61](#)
- [Fan Module LEDs, on page 62](#)
- [Power Supply LEDs, on page 62](#)

Switch Chassis LEDs

The BCN, STS, and ENV, LEDs are located on the left side of the front of the switch. The port LEDs appear as triangles pointing up or down to the nearest port.

LED	Color	Status
BCN	Flashing blue	The operator has activated this LED to identify this switch in the chassis.
	Off	This switch is not being identified.
STS	Green	The switch is operational.
	Flashing amber	The switch is booting up.
	Amber	Temperature exceeds the minor alarm threshold.
	Red	Temperature exceeds the major alarm threshold.
	Off	The switch is not receiving power.
ENV	Green	Fans and power supply modules are operational.
	Amber	At least one fan or power supply module is not operating.

LED	Color	Status
(port)	Green	Port admin state is 'Enabled', SFP is present and the interface is connected (that is, cabled, and the link is up).
	Amber	Port admin state is 'Disabled', or the SFP is absent, or both.
	Off	Port admin state is 'Enabled' and SFP is present, but interface is not connected.

Fan Module LEDs

The fan module LED is located below the air holes on the front of the module.

LED	Color	Status
STS	Green	The fan module is operational.
	Red	The fan module is not operational (fan is probably not functional).
	Off	Fan module is not receiving power.

Power Supply LEDs

The power supply LEDs are located on the left front portion of the power supply. Combinations of states that are indicated by the Okay (PS_OK) and Fault (AC_OK) LEDs indicate the status for the module as shown in the following table.

PS_OK LED	AC_OK LED	Status
Green	Off	Power supply is on and outputting power to the switch.
Flashing green	Off	Power supply is connected to a power source but not outputting power to the switch.
Green	Flashing amber	Power supply warning—possibly one of the following conditions: <ul style="list-style-type: none"> • High voltage • High power • Low voltage • Slow power supply fan

PS_OK LED	AC_OK LED	Status
Green	Amber	Rotor fault Note This behavior occurs if the fan rotor is stopped during normal switch operation.
Off	Amber	AC cord that is removed while in redundant mode (while other PSU is running).



APPENDIX **D**

Additional Kits

- [Rack Mount Kit for a Two-Post Rack, on page 65](#)
- [Rack Mount Kit NXK-ACC-KIT-1RU, on page 65](#)
- [Rack Mount Kit N3K-C3064-ACC-KIT, on page 66](#)

Rack Mount Kit for a Two-Post Rack

The following table lists and illustrates the contents for the two-post rack-mount kit (NXK-ACC-KIT-2P).

Illustration	Description	Quantity
	<ul style="list-style-type: none"> • Rack-mount kit • Bracket (2) • 2 Phillips pan-head screws • Number-8 Phillips flat-head screws (8) 	1

Rack Mount Kit NXK-ACC-KIT-1RU

The following table lists and illustrates the contents for the 1-RU rack-mount kit (NXK-ACC-KIT-1RU).

Illustration	Description	Quantity
	<ul style="list-style-type: none"> • Rack-mount kit • Front brackets (2) • Rear brackets (2) • Slider rails (2) • M4 Phillips pan-head screws (6) 	1

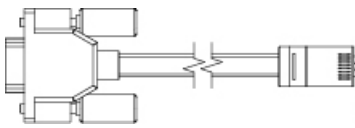
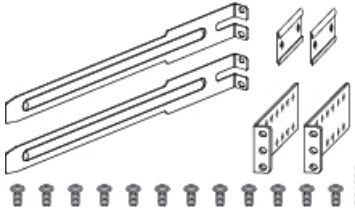

Illustration	Description	Quantity
 501337	Ground lug kit <ul style="list-style-type: none"> • Two-hole lug (1) • M4 x 8-mm Phillips pan-head screws (2) 	1
Not applicable	EAC Compliance document	1
Not applicable	Hazardous substances list for customers in China	1

The following table lists and illustrates the console cable (CAB-CONSOLE-RJ45) that can be ordered.

Illustration	Description	Quantity
 501288	Console cable with DB-9F and RJ-45F connectors	1

Rack Mount Kit N3K-C3064-ACC-KIT

The following table lists and illustrates the contents for the 1-RU rack-mount kit (N3K-C3064-ACC-KIT).

Illustration	Description	Quantity
 501308	Rack-mount kit <ul style="list-style-type: none"> • Front-mount angled bracket (2) • Rear-mount slider bracket (2) • Slider rails (2) • M4 x 7 mm mounting screws (16) 	1
 501337	Ground lug kit <ul style="list-style-type: none"> • Two-hole lug (1) • M4 x 8-mm Phillips pan-head screws (2) 	1
Not applicable	EAC Compliance document	1
Not applicable	Hazardous substances list for customers in China	1

The following table lists and illustrates the console cable (CAB-CONSOLE-RJ45) that can be ordered.

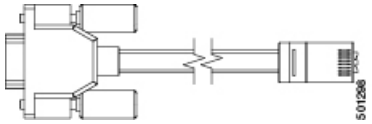
Illustration	Description	Quantity
	Console cable with DB-9F and RJ-45F connectors	1



APPENDIX **E**

Site Preparation and Maintenance Records

- [Site Preparation Checklist, on page 69](#)
- [Contact and Site Information, on page 70](#)
- [Chassis and Module Information, on page 71](#)

Site Preparation Checklist

Planning the location and layout of your equipment rack or cabinet is essential for successful switch operation, ventilation, and accessibility.

The following table lists the site planning tasks that we recommend that you complete before you install the switch. Your completion of each task ensures a successful switch installation.

Planning Activity	Verification Time and Date
Space evaluation:	
Space and layout	
Floor covering	
Impact and vibration	
Lighting	
Physical access	
Maintenance access	
Environmental evaluation:	
Ambient temperature	
Humidity	
Altitude	
Atmospheric contamination	
Airflow	

Planning Activity	Verification Time and Date
Power evaluation:	
Input power type	
Power receptacles	
Receptacle proximity to the equipment	
Dedicated (separate) circuits for power redundancy	
UPS for power failures	
Grounding: proper wire gauge and lugs	
Circuit breaker size	
Grounding evaluation:	
Data center ground	
Cable and interface equipment evaluation:	
Cable type	
Connector type	
Cable distance limitations	
Interface equipment (transceivers)	
EMI evaluation:	
Distance limitations for signaling	
Site wiring	
RFI levels	

Contact and Site Information

Use the following worksheet to record contact and site information for the installation.

Contact person	
Contact phone	

Contact e-mail	
Building/site name	
Data center location	
Floor location	
Address (line 1)	
Address (line 2)	
City	
State/Province	
Contact person	
ZIP/postal code	
Country	

Chassis and Module Information

Use the following worksheet to record information about the switch.

Contract number	
Chassis serial number	
Product number	

Use the following worksheet to record network-related information.

Switch IP address	
Switch IP netmask	
Hostname	
Domain name	
IP broadcast address	
Gateway/router address	
DNS address	

Use the following worksheet to record information about the modules in the switch.

Module Slot	Module Type	Module Serial Number	Notes
Fan module 1			

Module Slot	Module Type	Module Serial Number	Notes
Fan module 2			
Fan module 3			
Power Supply 1			
Power Supply 2			