



Cisco Nexus 93216TC-FX2 ACI-Mode Switch Hardware Installation Guide

First Published: 2019-09-16

Americas Headquarters

Cisco Systems, Inc.
170 West Tasman Drive
San Jose, CA 95134-1706
USA
<http://www.cisco.com>
Tel: 408 526-4000
800 553-NETS (6387)
Fax: 408 527-0883

THE SPECIFICATIONS AND INFORMATION REGARDING THE PRODUCTS REFERENCED IN THIS DOCUMENTATION ARE SUBJECT TO CHANGE WITHOUT NOTICE. EXCEPT AS MAY OTHERWISE BE AGREED BY CISCO IN WRITING, ALL STATEMENTS, INFORMATION, AND RECOMMENDATIONS IN THIS DOCUMENTATION ARE PRESENTED WITHOUT WARRANTY OF ANY KIND, EXPRESS OR IMPLIED.

The Cisco End User License Agreement and any supplemental license terms govern your use of any Cisco software, including this product documentation, and are located at: <http://www.cisco.com/go/softwareterms>. Cisco product warranty information is available at <http://www.cisco.com/go/warranty>. US Federal Communications Commission Notices are found here <http://www.cisco.com/c/en/us/products/us-fcc-notice.html>.

IN NO EVENT SHALL CISCO OR ITS SUPPLIERS BE LIABLE FOR ANY INDIRECT, SPECIAL, CONSEQUENTIAL, OR INCIDENTAL DAMAGES, INCLUDING, WITHOUT LIMITATION, LOST PROFITS OR LOSS OR DAMAGE TO DATA ARISING OUT OF THE USE OR INABILITY TO USE THIS MANUAL, EVEN IF CISCO OR ITS SUPPLIERS HAVE BEEN ADVISED OF THE POSSIBILITY OF SUCH DAMAGES.

Any products and features described herein as in development or available at a future date remain in varying stages of development and will be offered on a when-and if-available basis. Any such product or feature roadmaps are subject to change at the sole discretion of Cisco and Cisco will have no liability for delay in the delivery or failure to deliver any products or feature roadmap items that may be set forth in this document.

Any Internet Protocol (IP) addresses and phone numbers used in this document are not intended to be actual addresses and phone numbers. Any examples, command display output, network topology diagrams, and other figures included in the document are shown for illustrative purposes only. Any use of actual IP addresses or phone numbers in illustrative content is unintentional and coincidental.

The documentation set for this product strives to use bias-free language. For the purposes of this documentation set, bias-free is defined as language that does not imply discrimination based on age, disability, gender, racial identity, ethnic identity, sexual orientation, socioeconomic status, and intersectionality. Exceptions may be present in the documentation due to language that is hardcoded in the user interfaces of the product software, language used based on RFP documentation, or language that is used by a referenced third-party product.

Cisco and the Cisco logo are trademarks or registered trademarks of Cisco and/or its affiliates in the U.S. and other countries. To view a list of Cisco trademarks, go to this URL: [www.cisco.com go trademarks](http://www.cisco.com/go/trademarks). Third-party trademarks mentioned are the property of their respective owners. The use of the word partner does not imply a partnership relationship between Cisco and any other company. (1721R)

© 2019 Cisco Systems, Inc. All rights reserved.



CONTENTS

PREFACE

Preface	vii
Audience	vii
Documentation Conventions	vii
Documentation Feedback	viii
Obtaining Documentation and Submitting a Service Request	viii

CHAPTER 1

Overview	1
Overview	1

CHAPTER 2

Preparing the Site	7
Temperature Requirements	7
Humidity Requirements	7
Altitude Requirements	7
Dust and Particulate Requirements	8
Minimizing Electromagnetic and Radio Frequency Interference	8
Shock and Vibration Requirements	9
Grounding Requirements	9
Planning for Power Requirements	9
Airflow Requirements	11
Rack and Cabinet Requirements	11
Clearance Requirements	12

CHAPTER 3

Installing the Chassis	15
Installation Options with Rack-Mount Kits	15
Install a Rack	16
Unpacking and Inspecting a New Switch	16

Planning How to Position the Chassis in the Rack	17
Installing the Chassis in a Two-Post Rack	18
Attaching Center-Mount Brackets to the Chassis	18
Installing the Chassis in a Two-Post Rack	19
Installing the Chassis in a Four-Post Rack	21
Installing the Switch using the N XK-ACC-RMK-2RU Rack-Mount Kit	21
Installing the Switch using the N9K-C9300-RMK Rack-mount Kit	25
Attaching the Bottom-Support Rails to the Rack	25
Attaching Front-Mount Brackets to the Chassis	28
Installing the Chassis in a Four-Post Rack	28
Installing the Airflow Vent NXA-ACC-BAV3	31
Grounding the Chassis	32
Starting the Switch	33

CHAPTER 4**Connecting the Switch to the ACI Fabric 37**

ACI Fabric Topology	37
Preparing to Connect to Other Devices	38
Connecting Leaf Switches to APICs	39
Connecting Leaf Switches to Spine Switches	40
Installing a Gigabit Ethernet module (GEM)	42
Virtual Port Channel Migration - Migration of Nodes from a First-Generation Switch to a Second-Generation Switch	42
Setting Up an Optional Console Interface	43
Setting Up an Optional Management Connection	44
Optic Transceiver Removal Using the Optics Extraction Tool	44
Maintaining Transceivers and Optical Cables	45

CHAPTER 5**Replacing Components 47**

Replacing a Fan Module During Operations	47
Replacing a Power Supply Module	48
Removing an AC Power Supply	48
Removing an HVAC/HVDC Power Supply	49
Removing a DC Power Supply	49
Installing an AC Power Supply	50

Installing an HVAC/HVDC Power Supply	51
Installing a DC Power Supply	52
Wiring a 48 V DC Electrical Connector Block	52

APPENDIX A

Rack Specifications	55
Overview of Racks	55
General Requirements for Cabinets and Racks	55
Requirements Specific to Standard Open Racks	56
Requirements Specific to Perforated Cabinets	56
Cable Management Guidelines	56

APPENDIX B

System Specifications	57
Environmental Specifications	57
Switch Dimensions	57
Switch and Module Weights and Quantities	58
Transceiver and Cable Specifications	58
Switch Power Input Requirements	58
Power Specifications	59
1200-W AC Power Supply Specifications	59
1200-W HVAC/HVDC Power Supply Specifications	59
930-W DC Power Supply Specifications	60
Power Cable Specifications	61
Power Cable Specifications for AC Power Supplies	61
HVAC/HVDC Power Cables Supported by ACI-Mode and NX-OS Mode Switches	62
DC Power Cable Specifications	63
Regulatory Standards Compliance Specifications	63

APPENDIX C

LEDs	65
Switch Chassis LEDs	65
Fan Module LEDs	66
Power Supply LEDs	66

APPENDIX D

Additional Kits	67
Rack Mount Kit NXK-ACC-RMK-2RU	67

Rack Mount Kit N9K-C9300-RMK 68

Vent Bracket 68



Preface

- [Audience, on page vii](#)
- [Documentation Conventions, on page vii](#)
- [Documentation Feedback, on page viii](#)
- [Obtaining Documentation and Submitting a Service Request , on page viii](#)

Audience

This publication is for hardware installers and network administrators who install, configure, and maintain Cisco Nexus switches.

Documentation Conventions

Command descriptions use the following conventions:

Convention	Description
bold	Bold text indicates the commands and keywords that you enter literally as shown.
<i>Italic</i>	Italic text indicates arguments for which the user supplies the values.
[x]	Square brackets enclose an optional element (keyword or argument).
[x y]	Square brackets enclosing keywords or arguments separated by a vertical bar indicate an optional choice.
{x y}	Braces enclosing keywords or arguments separated by a vertical bar indicate a required choice.
[x {y z}]	Nested set of square brackets or braces indicate optional or required choices within optional or required elements. Braces and a vertical bar within square brackets indicate a required choice within an optional element.
<i>variable</i>	Indicates a variable for which you supply values, in context where italics cannot be used.

Convention	Description
string	A nonquoted set of characters. Do not use quotation marks around the string or the string will include the quotation marks.

Examples use the following conventions:

Convention	Description
<code>screen font</code>	Terminal sessions and information the switch displays are in screen font.
boldface screen font	Information you must enter is in boldface screen font.
<i>italic screen font</i>	Arguments for which you supply values are in italic screen font.
<>	Nonprinting characters, such as passwords, are in angle brackets.
[]	Default responses to system prompts are in square brackets.
!, #	An exclamation point (!) or a pound sign (#) at the beginning of a line of code indicates a comment line.

Documentation Feedback

To provide technical feedback on this document, or to report an error or omission, please send your comments to . We appreciate your feedback.

Obtaining Documentation and Submitting a Service Request

For information on obtaining documentation, using the Cisco Bug Search Tool (BST), submitting a service request, and gathering additional information, see *What's New in Cisco Product Documentation*, at: <https://www.cisco.com/warp/public/687/Directory/DirTAC.shtml>.

Subscribe to *What's New in Cisco Product Documentation*, which lists all new and revised Cisco technical documentation as an RSS feed and delivers content directly to your desktop using a reader application. The RSS feeds are a free service.



CHAPTER 1

Overview

- [Overview, on page 1](#)

Overview

The Cisco Nexus 93216TC-FX2 switch (N9K-C93216TC-FX2) is a 2-rack unit (RU), fixed-port switch designed for spine-leaf-APIC deployment in data centers. This switch has the following ports:

- 96 100M/1G/10G RJ45 ports
- 12 40/100-Gigabit QSFP28 ports
- 2 management ports (one RJ-45 port and one SFP port)
- 1 console port
- 1 USB port



Note 1-Gigabit QSA transceivers are not supported in uplink ports.



Note Autonegotiation is supported on 100M/1G/10G ports.

This switch includes the following user-replaceable components:

- Fan modules (three) with the following airflow choices:
 - Port-side exhaust fan module with blue coloring (NXA-FAN-160CFM-PE)
 - Port-side intake fan module with burgundy coloring (NXA-FAN-160CFM-PI)



Note *Table 1: Fan Speeds for this Switch*

	Port-Side Intake Fan Speed %	Port-Side Exhaust Fan Speed %
Typical/Minimum	40%	70%
Maximum	90%	90%

- Power supply modules (two—one for operations and one for redundancy [1+1]) with the following choices:
 - 1200-W port-side exhaust AC power supply with blue coloring (NXA-PAC-1200W-PE)
 - 1200-W port-side intake AC power supply with burgundy coloring (NXA-PAC-1200W-PI)
 - 1200-W HVAC/HVDC dual-direction airflow power supply with white coloring (N9K-PUV-1200W)
 - 930-W port-side exhaust DC power supply with blue coloring (NXA-PDC-930W-PE)
 - 930-W port-side intake DC power supply with burgundy coloring (NXA-PDC-930W-PI)



Note 930-W DC power supply support 1+1 redundancy requires both of the following conditions:

- Ambient temperature of 104°F (40°C) or less and
- Use of 3.5 W QSFP+ transceivers or passive QSFP cables

With higher temperatures or other optics, the switch requires both power supplies for operations without power redundancy.



Note Both power supplies should be the same type. Do not mix AC, DC, or HVAC/HVDC power supplies.



Note All fan modules and power supplies must use the same airflow direction. If you are using the 1200-W HVAC/HVDC power supplies, those power supplies automatically use the same airflow direction as used by the fan modules.

The following figure shows the switch features on the port side of the chassis.

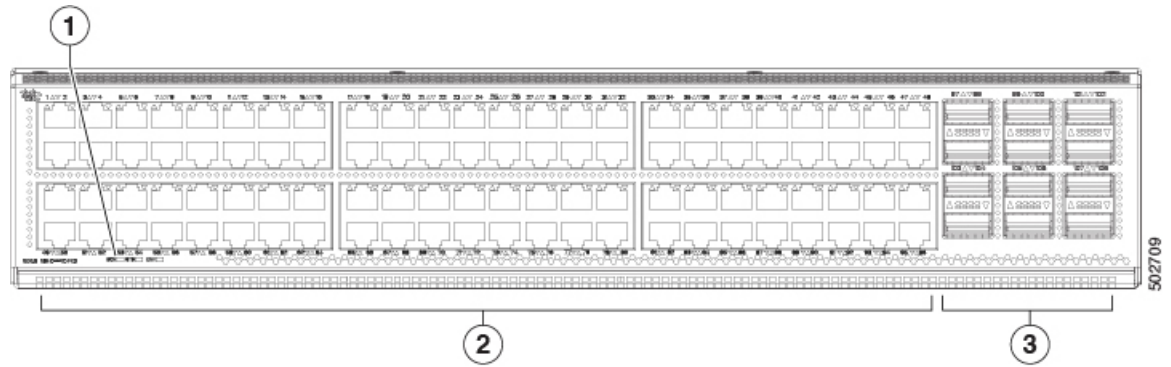

1	Beacon (BCN), Status (STS), and Environment (ENV) LEDs	3	12 40/100-Gigabit QSFP28 ports
2	96 100M/1G/10G RJ45 ports		

To determine which transceivers, adapters, and cables are supported by this switch, see the [Cisco Transceiver Modules Compatibility Information](#) document.

The following figure shows the switch features on the power supply side of the chassis.

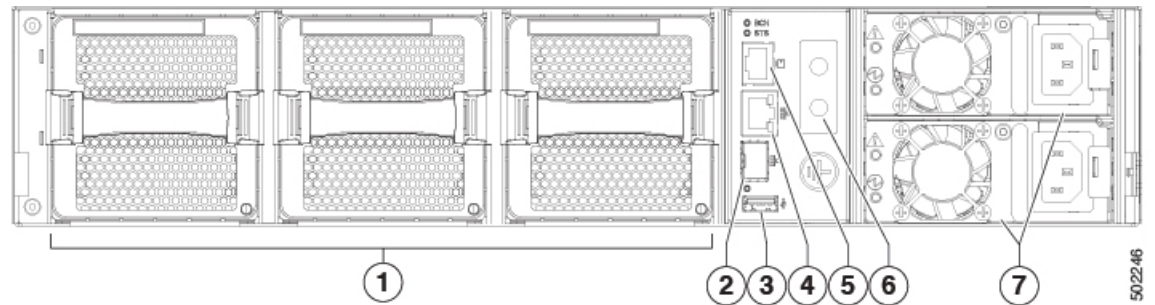

1	Fan modules (3) with slots numbered from 1 (left) to 3 (right)	5	Console port (1)
2	Management port (1—SFP optical port)	6	Grounding pad
3	USB port (1)	7	Power supply modules (1 or 2) (AC power supplies shown) with slots numbered 1 (top) and 2 (bottom)
4	Management port (1—RJ-45 copper port)		

The following figure shows the side of the chassis.

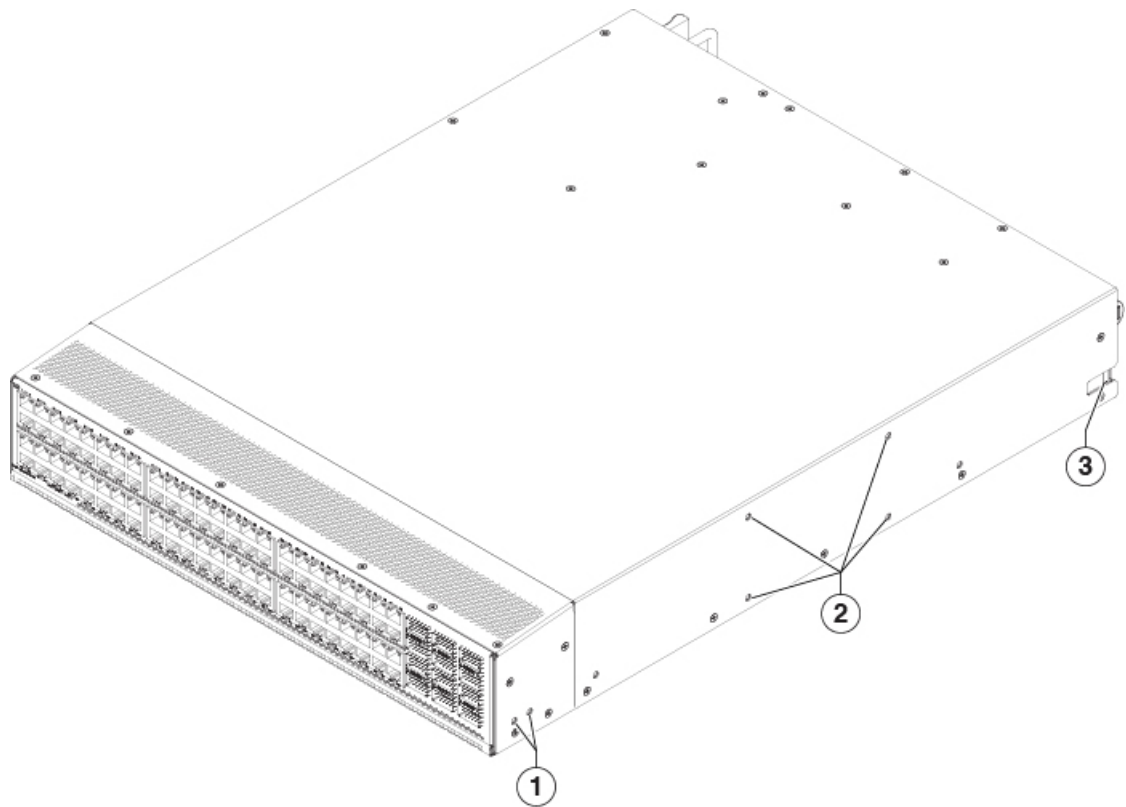

1	Screw holes for front mounting brackets (four-post rack installations)	3	Notch on both sides of the chassis for locking the power supply end of the chassis to the bottom support rails (four-post rack installations).
2	Screw holes for center-mount bracket (two-post rack installations)		



Note The access panel for DIMM upgrade is located on the underside of the chassis and uses Philips flat-head screws, M3x0.5x5mmL, CSwZNwPCH, 121'.

Depending on whether you plan to position the ports in a hot or cold aisle, you can order the fan and power supply modules with port-side intake or port-side exhaust airflow. For port-side intake airflow, the fan and AC power supply modules have burgundy coloring. For port-side exhaust airflow, the fan and AC power supplies have blue coloring. You can also order the 1200-W HVAC/HVDC power supply which has dual-direction airflow with white coloring. Dual-direction airflow modules automatically use the airflow direction of the other modules installed in the switch.

The fan and power supply modules are field replaceable and you can replace one fan module or one power supply module during operations so long as the other modules are installed and operating. If you have only one power supply installed, you can install the replacement power supply in the open slot before removing the original power supply.



Note All of the fan and power supply modules must have the same direction of airflow. Otherwise, the switch can overheat and shut down. If you are installing a dual-direction power supply, that module will automatically use the same airflow direction as the other modules in the switch.



Caution If the switch has port-side intake airflow (burgundy coloring for fan modules), you must locate the ports in the cold aisle. If the switch has port-side exhaust airflow (blue coloring for fan modules), you must locate the ports in the hot aisle. If you locate the air intake in a hot aisle, the switch can overheat and shut down.



CHAPTER 2

Preparing the Site

- [Temperature Requirements, on page 7](#)
- [Humidity Requirements, on page 7](#)
- [Altitude Requirements, on page 7](#)
- [Dust and Particulate Requirements, on page 8](#)
- [Minimizing Electromagnetic and Radio Frequency Interference, on page 8](#)
- [Shock and Vibration Requirements, on page 9](#)
- [Grounding Requirements, on page 9](#)
- [Planning for Power Requirements, on page 9](#)
- [Airflow Requirements, on page 11](#)
- [Rack and Cabinet Requirements, on page 11](#)
- [Clearance Requirements, on page 12](#)

Temperature Requirements

The switch requires an operating temperature of 32 to 104 degrees Fahrenheit (0 to 40 degrees Celsius). If the switch is not operating, the temperature must be between –40 to 158 degrees Fahrenheit (–40 to 70 degrees Celsius).

Humidity Requirements

Buildings in which the climate is controlled by air-conditioning in the warmer months and by heat during the colder months usually maintain an acceptable level of humidity for the switch equipment. However, if the switch is located in an unusually humid location, use a dehumidifier to maintain the humidity within an acceptable range.

Altitude Requirements

Altitude rating is based on power supply installed; see critical components list in the system CB report for altitude rating.

Dust and Particulate Requirements

Exhaust fans cool power supplies and system fans cool switches by drawing in air and exhausting air out through various openings in the chassis. However, fans also ingest dust and other particles, causing contaminant buildup in the switch and increased internal chassis temperature. Dust and particles can act as insulators and interfere with the mechanical components in the switch. A clean operating environment can greatly reduce the negative effects of dust and other particles.

In addition to keeping your environment free of dust and particles, follow these precautions to avoid contamination of your switch:

- Do not permit smoking near the switch.
- Do not permit food or drink near the switch.

Minimizing Electromagnetic and Radio Frequency Interference

Electromagnetic interference (EMI) and radio frequency interference (RFI) from the switch can adversely affect other devices, such as radio and television (TV) receivers. Radio frequencies that emanate from the switch can also interfere with cordless and low-power telephones. Conversely, RFI from high-power telephones can cause spurious characters to appear on the switch monitor.

RFI is defined as any EMI with a frequency above 10 kHz. This type of interference can travel from the switch to other devices through the power cable and power source or through the air as transmitted radio waves. The Federal Communications Commission (FCC) publishes specific regulations to limit the amount of EMI and RFI that are emitted by computing equipment. Each switch meets these FCC regulations.

To reduce the possibility of EMI and RFI, follow these guidelines:

- Cover all open expansion slots with a blank filler plate.
- Always use shielded cables with metal connector shells for attaching peripherals to the switch.

When wires are run for any significant distance in an electromagnetic field, interference can occur to the signals on the wires with the following implications:

- Bad wiring can result in radio interference emanating from the plant wiring.
- Strong EMI, especially when it is caused by lightning or radio transmitters, can destroy the signal drivers and receivers in the chassis and even create an electrical hazard by conducting power surges through lines into equipment.



Note

To predict and prevent strong EMI, you need to consult experts in radio frequency interference (RFI).

The wiring is unlikely to emit radio interference if you use a twisted-pair cable with a good distribution of grounding conductors. If you exceed the recommended distances, use a high-quality twisted-pair cable with one ground conductor for each data signal when applicable.

**Caution**

If the wires exceed the recommended distances, or if wires pass between buildings, give special consideration to the effect of a lightning strike in your vicinity. The electromagnetic pulse that is caused by lightning or other high-energy phenomena can easily couple enough energy into unshielded conductors to destroy electronic switches. You will want to consult experts in electrical surge suppression and shielding if you had similar problems in the past.

Shock and Vibration Requirements

The switch has been shock- and vibration-tested for operating ranges, handling, and earthquake standards.

Grounding Requirements

The switch is sensitive to variations in voltage that is supplied by the power sources. Overvoltage, undervoltage, and transients (or spikes) can erase data from memory or cause components to fail. To protect against these types of problems, ensure that there is an earth-ground connection for the switch. You can connect the grounding pad on the switch either directly to the earth-ground connection or to a fully bonded and grounded rack.

When you properly install the chassis in a grounded rack, the switch is grounded because it has a metal-to-metal connection to the rack. Alternatively, you can ground the chassis by using a customer-supplied grounding cable that meets your local and national installation requirements. For U.S. installations, we recommend 6-AWG wire. Connect your grounding cable to the chassis with a grounding lug (provided in the switch accessory kit) and to the facility ground.

**Note**

You automatically ground AC power supplies when you connect them to AC power sources. For DC power supplies, you must connect a grounding wire when wiring the power supply to the DC power source.

**Note**

An electrical conducting path shall exist between the product chassis and the metal surface of the enclosure or rack in which it is mounted or to a grounding conductor. Electrical continuity shall be provided by using thread-forming type mounting screws that remove any paint or non-conductive coatings and establish a metal-to-metal contact. Any paint or other non-conductive coatings shall be removed on the surfaces between the mounting hardware and the enclosure or rack. The surfaces shall be cleaned and an antioxidant applied before installation.

Planning for Power Requirements

The switch includes two power supplies (1-to-1 redundancy with current sharing) in one of the following combinations:

- Two 1200-W AC power supplies
- Two 1200-W HVAC/HVDC power supplies

- Two 930-W DC power supplies



Note For $n+1$ redundancy, you can use one or two power sources for the two power supplies. For $n+n$ redundancy, you must use two power sources and connect each power supply to a separate power source.

The power supplies are rated to output up to 1200 W (AC and HVAC/HVDC power supplies) to the switch, but the switch requires less than that amount of power from the power supply. To operate the switch, you must provision enough power from the power source to cover the requirements of both the switch and a power supply. Typically, this switch and a power supply require about 429 W of power input from the power source, but you must provision as much as 1245 W power input from the power source to cover peak demand.



Note Some of the power supply modules have rating capabilities that exceed the switch requirements. When calculating your power requirements, use the switch requirements to determine the amount of power that is required for the power supplies.

To minimize the possibility of circuit failure, make sure that each power-source circuit that is used by the switch is dedicated to the switch.



Note For AC input application, please refer to the following statement:



Warning Statement 1005—Circuit Breaker

This product relies on the building's installation for short-circuit (overcurrent) protection. Ensure that the protective devices are rated not greater than 20A (North America), 16A (Europe), and 13A (UK).



Note For DC input application, please refer to the following statement:



Warning Statement 1005—Circuit Breaker

This product relies on the building's installation for short-circuit (overcurrent) protection.

- Ensure that the protective devices are rated not greater than 30A when the switch is powered with regular DC power supplies (rated 48-60VDC).
- Ensure that the protective devices are rated not greater than 10A when the switch is powered with HVDC power supplies (rated 240-350VDC).

**Warning Statement 1033**

Connect the unit only to DC power source that complies with the Safety Extra-Low Voltage (SELV) requirements in IEC 60950 based safety standards.



Note We recommend 8-AWG wire for DC installations in the U.S.



Note For the power cables to use with the power supplies, see [Power Cable Specifications, on page 61](#).

Airflow Requirements

The switch is positioned with its ports in either the front or the rear of the rack depending on your cabling and maintenance requirements. You must have fan and power supply modules that move the coolant air from the cold aisle to the hot aisle in one of the following ways:

- Port-side exhaust airflow—Cool air enters the chassis through the fan and power supply modules in the cold aisle and exhausts through the port end of the chassis in the hot aisle.
- Port-side intake airflow—Cool air enters the chassis through the port end in the cold aisle and exhausts through the fan and power supply modules in the hot aisle.

You can identify the airflow direction of each fan and power supply module by its coloring as follows:

- Blue coloring indicates port-side exhaust airflow.
- Burgundy coloring indicates port-side intake airflow.
- White coloring on HVAC/HVDC power supplies indicates dual-direction airflow.



Note To prevent the switch from overheating and shutting down, you must position the air intake for the switch in a cold aisle. The fan and power supply modules must have the same direction of airflow (even if their coloring is different). If you must change the airflow direction for the switch, you must shutdown the switch before changing the modules.

Rack and Cabinet Requirements

You can install the following types of racks or cabinets for your switch:

- Standard perforated cabinets
- Solid-walled cabinets with a roof fan tray (bottom-to-top cooling)

- Standard open four-post Telco racks

Work with your cabinet vendors to determine which of their cabinets meet the following requirements or see the Cisco Technical Assistance Center (TAC) for recommendations:

- Use a standard 19-inch (48.3-cm), four-post Electronic Industries Alliance (EIA) cabinet or rack with mounting rails that conform to English universal hole spacing per section 1 of the ANSI/EIA-310-D-1992 standard.
- The depth of a four-post rack must be 24 to 32 inches (61.0 to 81.3 cm) between the front and rear mounting rails (for proper mounting of the bottom-support brackets or other mounting hardware).

Also, you must have power receptacles that are located within reach of the power cords that are used with the switch.



Warning Statement 1048—Rack Stabilization

The rack stabilizing mechanism must be in place, or the rack must be bolted to the floor before installation or servicing. Failure to stabilize the rack can cause bodily injury.

Clearance Requirements

Provide the chassis with adequate clearance between the chassis and any other rack, device, or structure so that you can properly install the chassis. Provide the chassis with adequate clearance to route cables, provide airflow, and maintain the switch. For the clearances required for an installation of this chassis in a four-post rack, see the following figure.

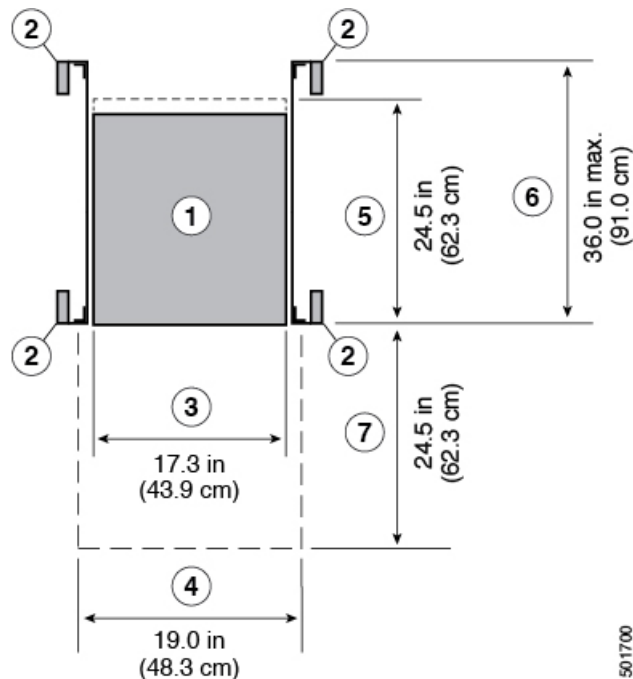

1	Chassis	5	Depth of the chassis
2	Vertical rack-mount posts and rails	6	Maximum extension of the bottom-support rails 36.0 in (91.0 cm)
3	Chassis width 17.3 in (43.9 cm)	7	Depth of the front clearance area (equal to the depth of the chassis).
4	Width of the front clearance area (equal to the width of the chassis with two rack-mount brackets that are attached to it). 19.0 in (48.3 cm)		



Note Both the front and rear of the chassis must be open to both aisles for airflow.



CHAPTER 3

Installing the Chassis

- [Installation Options with Rack-Mount Kits, on page 15](#)
- [Install a Rack, on page 16](#)
- [Unpacking and Inspecting a New Switch, on page 16](#)
- [Planning How to Position the Chassis in the Rack, on page 17](#)
- [Installing the Chassis in a Two-Post Rack, on page 18](#)
- [Installing the Chassis in a Four-Post Rack, on page 21](#)
- [Installing the Airflow Vent NXA-ACC-BAV3, on page 31](#)
- [Grounding the Chassis, on page 32](#)
- [Starting the Switch, on page 33](#)

Installation Options with Rack-Mount Kits

The rack-mount kit enables you to install the switch into racks of varying depths. You can position the switch with easy access to either the port connections or the fan and power supply modules.

You can install the switch using the following rack-mount options:

- Rack-mount kit (NXX-ACC-RMK-2RU) which you can order from Cisco. This option offers you easy installation, greater stability, increased weight capacity, added accessibility, and improved removability with front and rear removal.

For four post racks.

- Rack-mount kit (N9K-C9300-RMK) which you can order from Cisco.

For four post racks.

The rack or cabinet that you use must meet the requirements listed the in [General Requirements for Cabinets and Racks, on page 55](#) section.



Note You are responsible for verifying that your rack and rack-mount hardware comply with the guidelines that are described in this doc.

Install a Rack

Before you install the switch, you must install a standard four-post, 19-inch EIA data center rack (or a cabinet that contains such a rack) that meets the requirements listed in [Overview of Racks, on page 55](#).

Step 1 Bolt the rack to the concrete subfloor before moving the chassis onto it.

Warning Statement 1048—Rack Stabilization

The rack stabilizing mechanism must be in place, or the rack must be bolted to the floor before installation or servicing. Failure to stabilize the rack can cause bodily injury.

Step 2 If the rack has bonded construction, connect it to the earth ground. This action enables you to easily ground the switch and its components and to ground your electrostatic discharge (ESD) wrist strap to prevent damaging discharges when you handle ungrounded components before installing them.

Step 3 Include one or two power sources at the rack. For AC power, provide a power receptacle. For DC power, provide a circuit breaker with terminals for connecting power cables.

Warning Statement 1018—Supply Circuit

To reduce risk of electric shock and fire, take care when connecting units to the supply circuit so that wiring is not overloaded.

Note If you are not using power redundancy or are using $n+1$ redundancy, you need only one power source. If you are using $n+n$ redundancy, you need two power sources.

Unpacking and Inspecting a New Switch

Before you install a new chassis, you need to unpack and inspect it to be sure that you have all the items that you ordered and verify that the switch was not damaged during shipment. If anything is damaged or missing, contact your customer representative immediately.



Caution

When you handle the chassis or its components, you must follow ESD protocol at all times to prevent ESD damage. This protocol includes but is not limited to wearing an ESD wrist strap that you connect to the earth ground.



Tip

Do not discard the shipping container when you unpack the switch. Flatten the shipping cartons and store them. If you need to move or ship the system in the future, you will need this container.

Step 1 Compare the shipment to the equipment list that is provided by your customer service representative and verify that you have received all of the ordered items.

The shipment should include the following:

- Switch chassis, which includes the following installed components:
 - Two power supplies (any combination of the following with the airflow direction being the same as for the fan modules):
 - fan modules (all fan and power supply modules must have the same airflow direction)
- Switch accessory kit

Step 2 Check the contents of the box for damage.

Step 3 If you notice any discrepancies or damage, send the following information to your customer service representative by email:

- Invoice number of the shipper (see the packing slip)
- Model and serial number of the missing or damaged unit
- Description of the problem and how it affects the installation

Planning How to Position the Chassis in the Rack

The switch is designed so that you can have coolant air flow through the switch in one of the two following directions:

- Enter the port side and exhaust out the power supply side (port-side intake airflow)
- Enter the power supply side and exhaust out the port side (port-side exhaust airflow)

For port-side intake airflow, the switch must have port-side intake fan and AC power supply modules with one or more of the following colorings:

- Burgundy coloring on fan modules and AC power supplies

For port-side exhaust airflow, the switch must have port-side exhaust fan and AC power supply modules with one or more of the following colorings:

- Blue coloring on fan modules and AC power supplies

You can plan the positioning of the switch so that its ports are located close to ports on connected devices or so that the fan and power supply modules are conveniently located in a maintenance aisle, and then order the modules that move coolant air in the appropriate direction from the cold aisle to the hot aisle.



Note All fan and power supply modules in the same switch must operate with the same direction of airflow and the air intake portion of the switch must be located in a cold aisle.

Installing the Chassis in a Two-Post Rack

Before you install the chassis, be sure that the rack is fully secured to the data center floor.

You must attach mounting brackets to the chassis before mounting the chassis.

Attaching Center-Mount Brackets to the Chassis

You need to attach a right-angled bracket to each side of the chassis. This bracket centers the chassis and secures it in place on a two-post rack.



Warning **Statement 1006**—Chassis Warning for Rack-Mounting and Servicing

To prevent bodily injury when mounting or servicing this unit in a rack, you must take special precautions to ensure that the system remains stable. The following guidelines are provided to ensure your safety:

- This unit should be mounted at the bottom of the rack if it is the only unit in the rack.
 - When mounting this unit in a partially filled rack, load the rack from the bottom to the top with the heaviest component at the bottom of the rack.
 - If the rack is provided with stabilizing devices, install the stabilizers before mounting or servicing the unit in the rack.
-

Before you begin

- You must separately order the center-mount brackets if you are installing the chassis in a two-post rack. These brackets do not ship with the chassis unless you specifically order them.
 - You must have the following tools and equipment:
 - Manual Phillips-head torque screwdriver
 - Center-mount bracket kit
-

Step 1 Align one of the two center-mount brackets on the left or right side of the chassis and be sure that the angled portion is facing the front of the chassis (see the following figure).

Be sure to align four of the screw holes on the larger side of the bracket with the four screw holes near the center of the left or right side of the chassis.

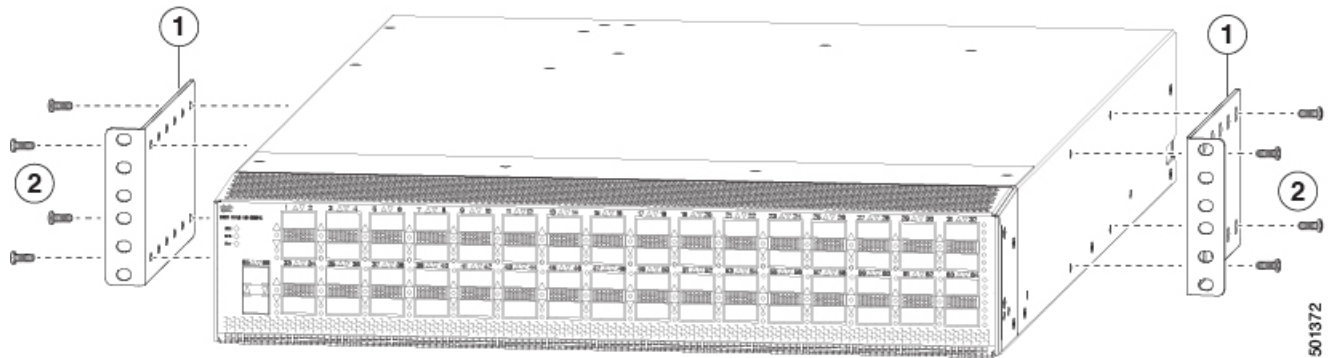

501372

1	Center-mount bracket with its larger side facing the chassis and the longer side facing the front (port side) of the chassis. Align four screw holes in the bracket to four screw holes in the side of the chassis.	2	Four M4 x 8 mm screws used to fasten the bracket to the chassis.
---	---	---	--

- Step 2** Use four M4 x 8 mm screws to attach the bracket to the chassis. Tighten each screw to 11 to 15 in-lb (1.2 to 1.7 N·m).
- Step 3** Repeat Steps 1 and 2 to attach the second center-mount bracket to the other side of the chassis.

What to do next

You are ready to mount the chassis to the two-post rack.

Installing the Chassis in a Two-Post Rack

You need to position the chassis near the top of the rack with the power supply and fan modules in the appropriate aisle for their required airflow. If the fan modules have a blue coloring for port-side exhaust airflow, then you must position the modules by the cold aisle. If the fan modules have a burgundy coloring for port-side intake airflow, you must position the modules by the hot aisle.



Note Power supply modules must have the same airflow direction as the fan modules.



Warning **Statement 1074**—Comply with Local and National Electrical Codes

To reduce risk of electric shock or fire, installation of the equipment must comply with local and national electrical codes.



Warning **Statement 1032**—Lifting the Chassis

To prevent personal injury or damage to the chassis, never attempt to lift or tilt the chassis using the handles on modules, such as power supplies, fans, or cards. These types of handles are not designed to support the weight of the unit.

Before you begin

- Make sure that the two-post rack is properly installed and secured to the concrete subfloor.
- Make sure that two center-mount brackets are securely fastened to the middle of each side of the chassis.
- Make sure that you have six customer-supplied rack-mount screws (typically M6 x 10 mm or the appropriate screw for the vertical mounting rails on the rack).
- You have at least two people to install the chassis.

**Warning Statement 1006**—Chassis Warning for Rack-Mounting and Servicing

To prevent bodily injury when mounting or servicing this unit in a rack, you must take special precautions to ensure that the system remains stable. The following guidelines are provided to ensure your safety:

- This unit should be mounted at the bottom of the rack if it is the only unit in the rack.
- When mounting this unit in a partially filled rack, load the rack from the bottom to the top with the heaviest component at the bottom of the rack.
- If the rack is provided with stabilizing devices, install the stabilizers before mounting or servicing the unit in the rack.

Step 1

Use one person to position the chassis so that it is near the top of the rack with the fan and power supply modules in the appropriate aisle and the center-mount bracket has its screw holes aligned to screw holes on the two-post rack.

If these modules have a blue coloring for port-side exhaust airflow, then you must position the modules by the cold aisle. If the modules have a burgundy coloring for port-side intake airflow, you must position the modules by the hot aisle.

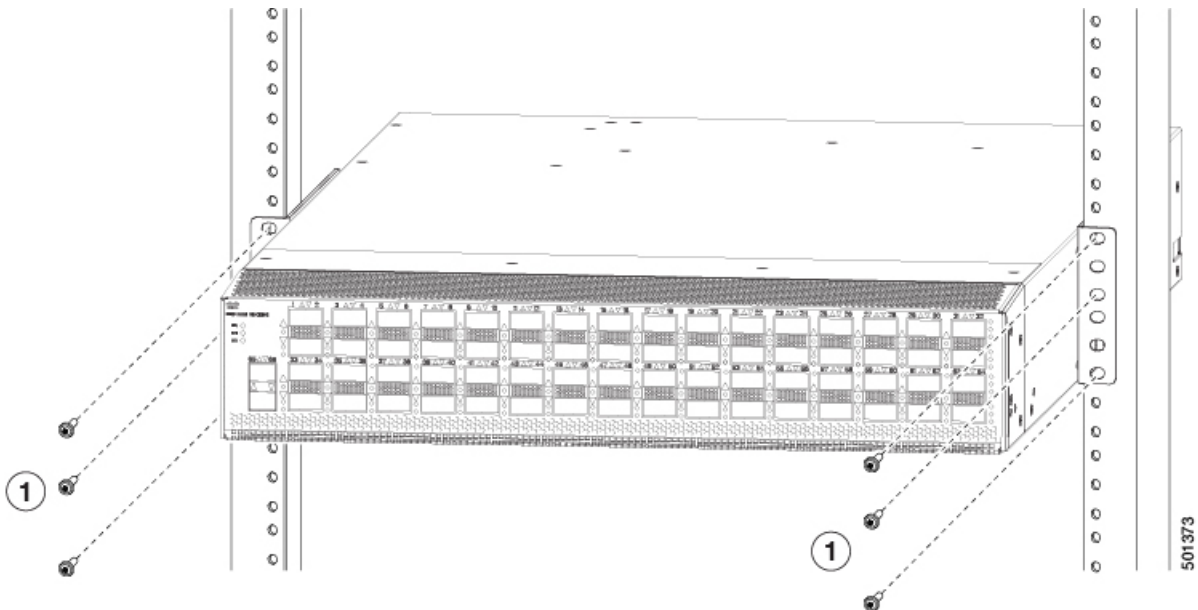

1	Three customer-supplied screws (typically M6 x 10 mm screws or the appropriate screws for the rack) to hold each side of the chassis to the two-post rack.		
---	--	--	--

- Step 2** Use the second person to secure the three customer-supplied rack-mount screws (typically M6 x 10 mm or other appropriate screws for the rack) on each center-mount bracket to attach the chassis to the rack. Tighten each screw to the appropriate torque setting for the screws (for M6 x 10 mm screws, use 40 in-lbs [4.5 N·m] of torque).

Installing the Chassis in a Four-Post Rack

Before you install the chassis, be sure that the rack is fully secured to the data center floor.

Installing the Switch using the NXK-ACC-RMK-2RU Rack-Mount Kit

To install the switch, you must attach mounting brackets to the rack, install slider rails on the rear of the rack, slide the switch onto the slider rails, install the retainer brackets, and secure the switch to the rack with the retainer clips. Typically, the front of the rack is the side easiest to access for maintenance.



Note You must supply the eight 10-32 or 12-24 screws required to mount the slider rails and switch to the rack.

Before you begin

- You have inspected the switch shipment to ensure that you have everything ordered.
- Make sure that the switch rack-mount kit includes the following parts:
 - Rack-mount brackets (2)
 - Rack-mount retainer brackets (2)
 - Rack-mount slider rails (2)
 - Rack-mount retainer clips (2)
 - Phillips countersink screws (8)
 - Flat head screws (4)
- The rack is installed and secured to its location.

Step 1 Install two rack-mount brackets to the rack as follows:

- a) Determine which end of the chassis is to be located in the cold aisle as follows:
 - If the switch has port-side intake modules (fan modules with burgundy coloring), position the front-mount brackets so that the switch ports will be in the cold aisle.

- If the switch has port-side exhaust modules (fan modules with blue coloring), position the front-mount brackets so that the switch fan and power supply modules will be in the cold aisle.
- b) Position a front-mount bracket so that it aligns to the desired position in the rack and secure the bracket with 12-24 screws or 10-32 screws, depending on the rack thread type (see the following figure). Tighten 12-24 screws to 30 in-lb (3.39 N·m) of torque and tighten 10-32 screws to 20 in-lb (2.26 N·m) of torque..

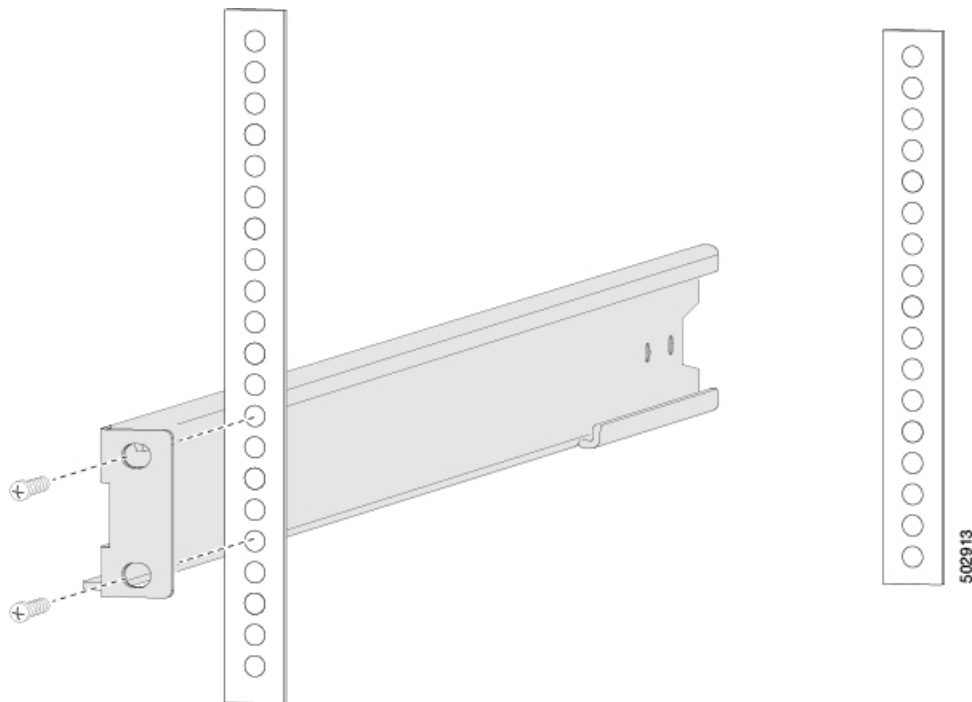

- c) Repeat Step 1 for the other front rack-mount bracket on the other side of the rack and be sure to position that bracket horizontally to the same level as first bracket.

Step 2 If you are not installing the chassis into a grounded rack, you must attach a customer-supplied grounding wire to the chassis as explained in [Grounding the Chassis, on page 32](#). If you are installing the chassis into a grounded rack, you can skip this step.

Step 3 Install the slider rails on the rack or cabinet as follows:

- a) Determine which two posts of the rack or cabinet you should use for the slider rails. Of the four vertical posts in the rack or cabinet, two will be used for the front mount brackets attached to the easiest accessed end of the chassis, and the other two posts will have the slider rails.
- b) Position a slider rail at the desired level on the back side of the rack and slide it into the front-mount bracket already installed and secure with 12-24 screws or 10-32 screws, depending on the rack thread type (see the following figure). Tighten 12-24 screws to 30 in-lb (3.39 N·m) of torque and tighten 10-32 screws to 20 in-lb (2.26 N·m) of torque.

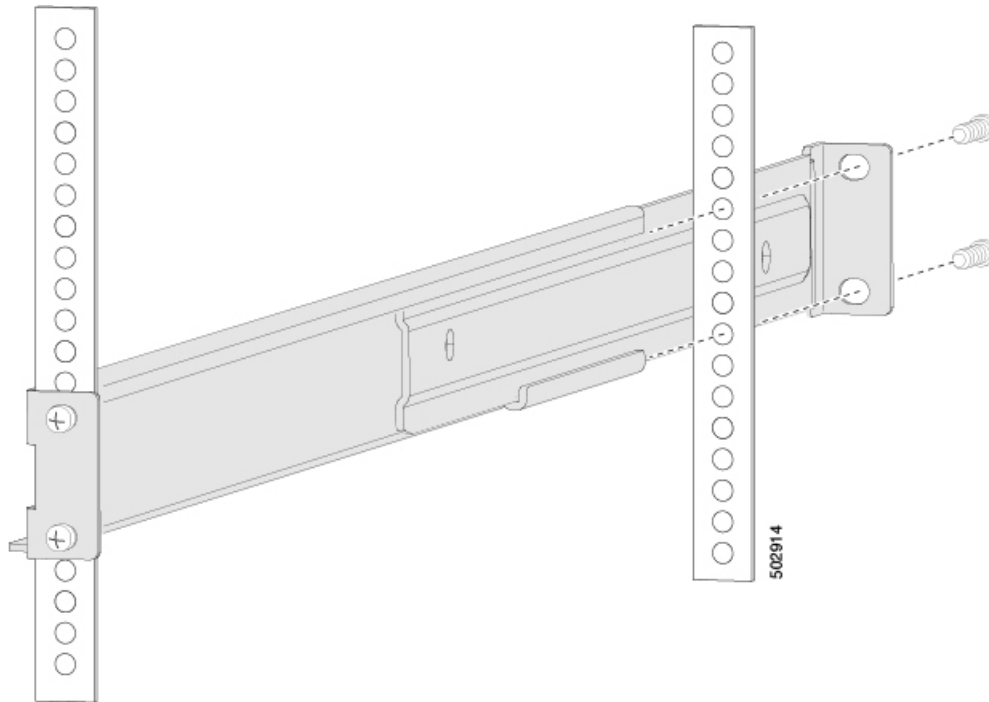

- c) Repeat Step 3 to attach the other slider rail to the other side of the rack.

To make sure that the slider rails are at the same level, you should use a level tool, tape measure, or carefully count the screw holes in the vertical mounting rails.

Step 4 Insert the switch into the rack and attach it as follows:

- a) Holding the switch with both hands, position the switch onto the rack-mount brackets and carefully slide the chassis into the rack (see the following figure).

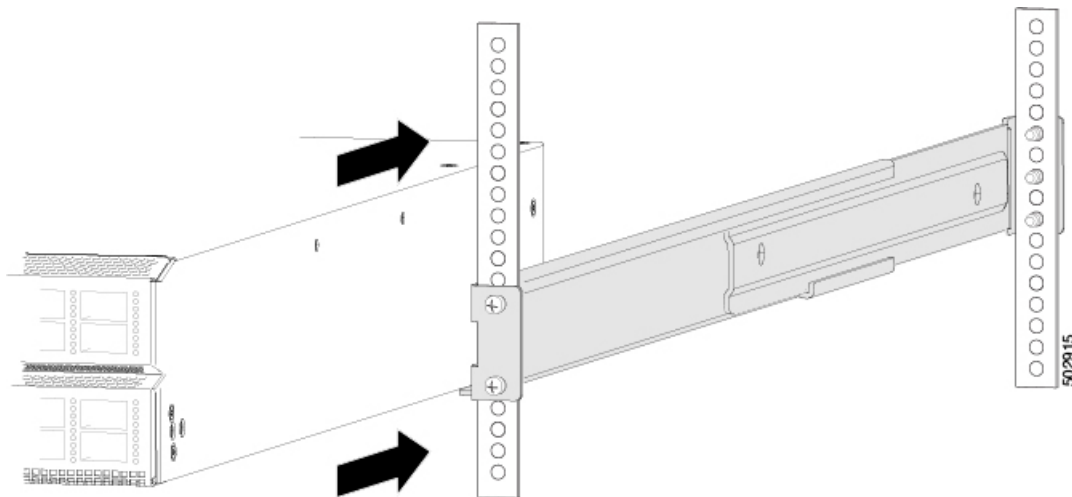

Step 5 Insert the rack-mount retainer brackets

- a) Align the retainer brackets to the front of the chassis, being careful not to damage anything on the front of the chassis (see the following figure).
 b) Repeat Step 5 to attach the other retainer bracket on other side of the chassis.

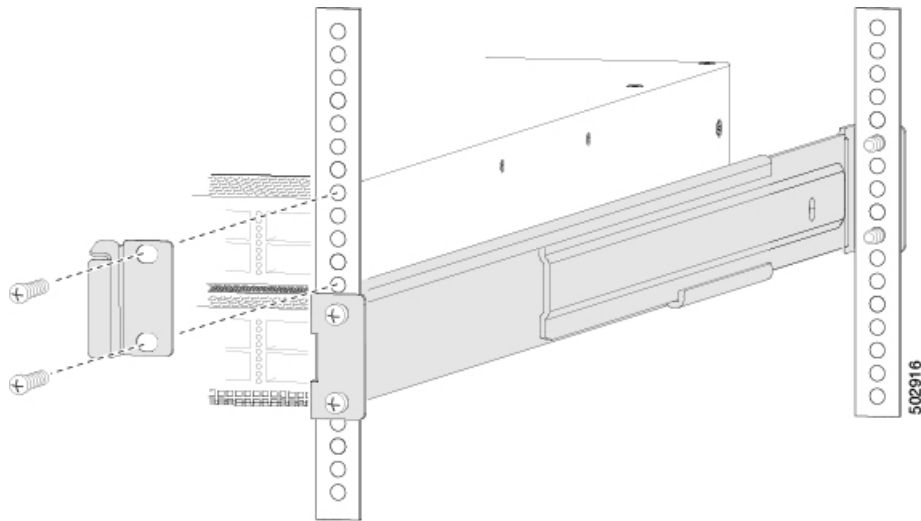

- c) Tighten the 10-32 screws to 20 in-lb (2.26 N·m) or tighten the 12-24 screws to 30 in-lb (3.39 N·m).

Step 6 Insert the retainer clip to hold the chassis in place.

- a) Align the retainer clip to the inside of the back of the slider rail. Make sure to hook the flange to the cutout on the bracket and align the screw holes (see the following figure).
- b) Attach the screws to secure the retainer clip (see the following figure).
- c) Repeat Step 6 to attach the other retainer clip on the other side of the chassis.

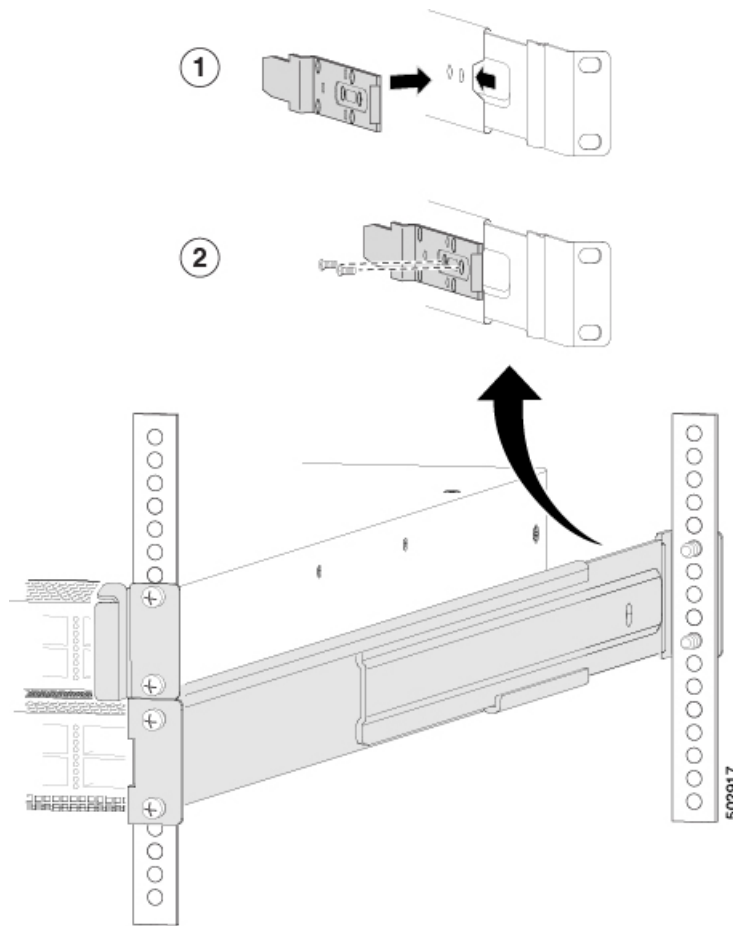

Step 7 If you attached a grounding wire to the chassis grounding pad, connect the other end of the wire to the facility ground.

Installing the Switch using the N9K-C9300-RMK Rack-mount Kit

Attaching the Bottom-Support Rails to the Rack

The switch chassis that you are installing ships with two adjustable bottom-support rails that you can attach to a four-post rack to hold the chassis. Each of these bottom-support rails has two pieces—one that slides into the other so that you can adjust them to fit racks with front and rear mounting posts that are spaced less than 36 inches (91 cm). On each bottom-support rail, the rail half that slides into the other rail includes a chassis stop that fits into the module end of the chassis. Depending on direction of the chassis airflow, you need to position the rail half with the chassis stop so that the fan and power supply modules end up in the appropriate aisle as follows:

- Port-side intake (burgundy coloring for fan modules) airflow requires that the bottom-support rail with the chassis stop be located on the hot aisle side of the rack.
- Port-side exhaust (blue coloring for fan modules) airflow requires that the bottom-support rail with the chassis stop be located on the cold aisle side of the rack.



Warning Statement 1074—Comply with Local and National Electrical Codes

To reduce risk of electric shock or fire, installation of the equipment must comply with local and national electrical codes.

Before you begin

Before you can install the bottom support rails for the chassis, you must do the following:

- Verify that a four-post rack or cabinet is installed.
- If any other devices are stored in the rack or cabinet, verify that the heavier switches are installed below lighter switches.
- Verify that the bottom-support rails kit is included in the switch accessory kit.
- Verify that you have 8 screws for attaching the bottom support brackets to the racks (typically M6 x 10 mm screws or the screw appropriate for the vertical mounting rails on the rack).



Warning Statement 1006—Chassis Warning for Rack-Mounting and Servicing

To prevent bodily injury when mounting or servicing this unit in a rack, you must take special precautions to ensure that the system remains stable. The following guidelines are provided to ensure your safety:

- This unit should be mounted at the bottom of the rack if it is the only unit in the rack.
 - When mounting this unit in a partially filled rack, load the rack from the bottom to the top with the heaviest component at the bottom of the rack.
 - If the rack is provided with stabilizing devices, install the stabilizers before mounting or servicing the unit in the rack.
-

-
- Step 1** Look at the fan and power supply modules installed in the chassis to determine how you must position the bottom-support rails on the rack.
- If the fan modules have blue coloring (port-side exhaust modules), you must position the bottom support rails so that the chassis stop is positioned by the cold aisle.
 - If the fan modules have burgundy (port-side intake modules), you must position the bottom support rails so that the chassis stop is positioned by the hot aisle.
- Step 2** Separate the two sliders that make up one bottom-support rail and position the half with the chassis stop by the appropriate aisle for the fan and power supply modules. Also make sure that there is at least 1 rack unit open above the bottom-support rails so that you can easily install the chassis.
- Step 3** Use two customer-supplied screws (typically M6 x 10 mm screws) to attach the bottom-support rail half to the vertical mounting rails on the rack post. Tighten each screw to the appropriate torque setting for the screws (for M6 x 10 mm screws, use 40 in. lbs [4.5 N·m] of torque).

- Step 4** Slide the other half of the bottom-support rail onto the attached half of the rail set and use two customer supplied screws (typically M6 x 10 mm screws) to secure that portion to the vertical mounting rails on the rack. Tighten each screw to the appropriate torque setting for the screws (for M6 x 10 mm screws, use 40 in. lbs [4.5 N·m] of torque).

Figure 1: Positioning an Expanding Bottom-Support Rail Set

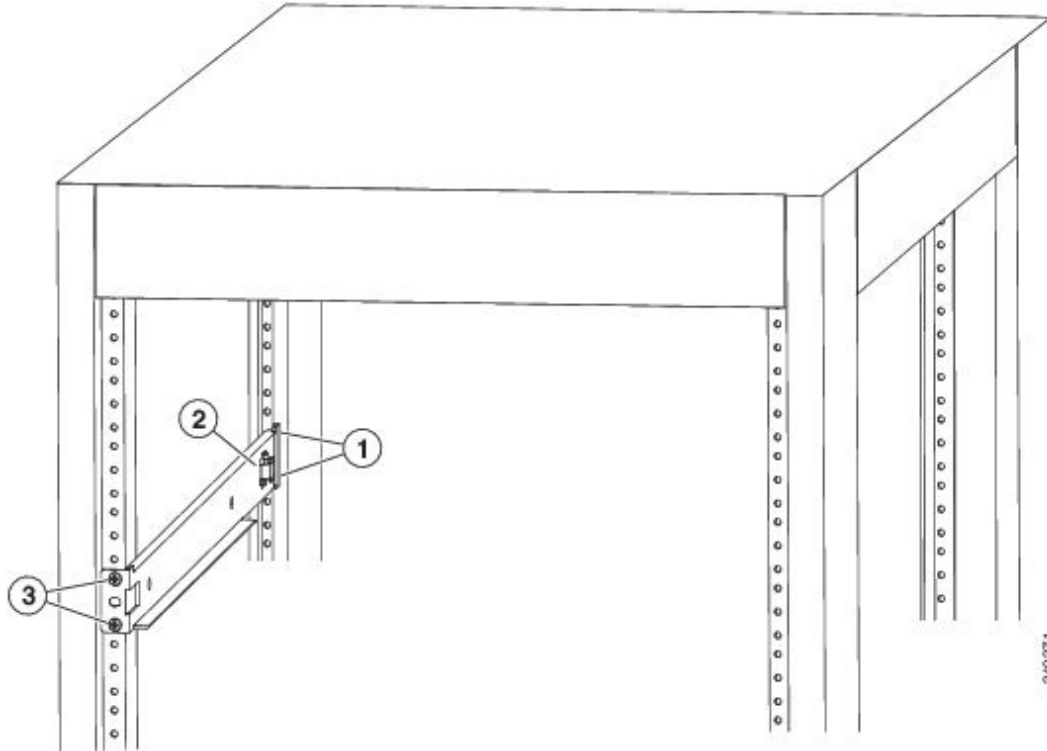

1	2 screws holding one end of the bottom-support bracket to the rear of the rack	3	2 screws holding the front end of the bottom-support bracket to the front side of the rack
2	Chassis stop on the expanding bottom-support bracket		

- Step 5** Repeat Steps 2 and 3 to attach the other expanding bottom-support rails to the other side of the rack.

Note Check the two installed bottom support rails to be sure that both have their chassis stops by the same aisle (either both by the hot aisle or both by the cold aisle) and that both rails are level and level with each other. If they are not level, adjust the higher rail down to the level of the lower rail.

What to do next

You are ready to install two front-mount brackets on the chassis.

Attaching Front-Mount Brackets to the Chassis

You need to attach a right-angled bracket to each side of the chassis. This bracket holds the chassis in place on a four-post rack.

Before you begin

- You must have the following tools and equipment:
 - Manual Phillips-head torque screwdriver
 - Front-mount brackets (2) and screws (4) (found inside the switch accessory kit)

Step 1 Align the two holes in one side of one of two front-mount brackets to two holes on the left or right side of the chassis (see the following figure).

Be sure that the other side of the bracket is facing toward the front (port end) of the chassis.

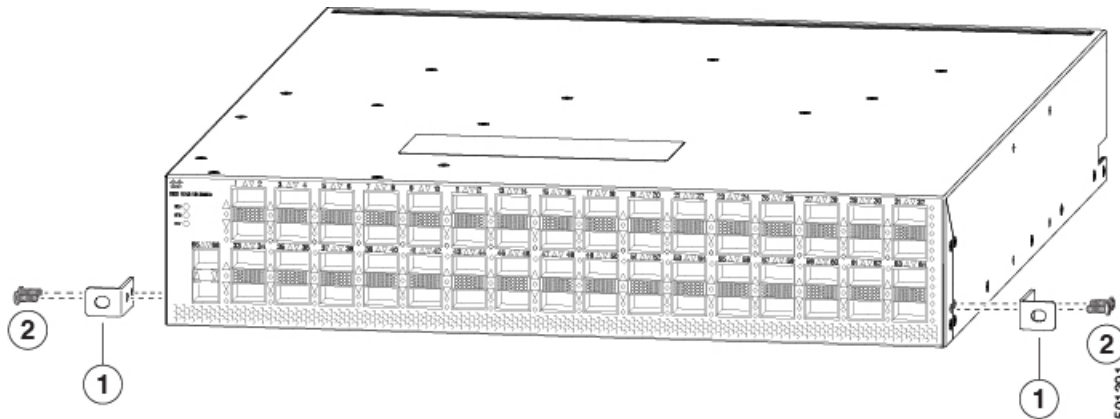

1	Front-mount bracket with two screw holes aligned to two screw holes in the chassis and one screw hole facing the front (port side) of the chassis.	2	Two M4 x 6 mm screws used to fasten the bracket to the chassis.
---	--	---	---

Step 2 Use two M4 x 6 mm screws to attach the bracket to the chassis. Tighten each screw to 11 to 15 in-lb (1.2 to 1.7 N·m).

Step 3 Repeat Steps 1 and 2 to attach the second center-mount bracket to the other side of the chassis.

What to do next

You are ready to mount the chassis to the four-post rack.

Installing the Chassis in a Four-Post Rack

You need to slide the chassis onto the bottom-support rails so that the power supply end locks onto the chassis stops at the end of the rails and so that the front-mount brackets on the chassis come into contact with the front-mount rails on the rack.



Warning Statement 1074—Comply with Local and National Electrical Codes

To reduce risk of electric shock or fire, installation of the equipment must comply with local and national electrical codes.



Warning Statement 1032—Lifting the Chassis

To prevent personal injury or damage to the chassis, never attempt to lift or tilt the chassis using the handles on modules, such as power supplies, fans, or cards. These types of handles are not designed to support the weight of the unit.

Before you begin

- Make sure that the four-post rack is properly installed and secured to the concrete subfloor.
- Make sure that the bottom-support rails are installed so that the fan modules will be in the appropriate aisle as follows:
 - Burgundy (port-side intake airflow) fan modules are positioned in a hot aisle (the chassis stop on the bottom-support rails is positioned by the hot aisle).
 - Blue colored (port-side exhaust airflow) fan modules are positioned in a cold aisle (the chassis stop on the bottom-support rails is positioned by the cold aisle).
- Make sure that two front-mount brackets are securely fastened to the sides of the chassis at the port end.
- Make sure that you have two customer-supplied rack-mount screws (M6 x 10 mm or appropriate screw for the vertical mounting rails on the rack).



Warning Statement 1006—Chassis Warning for Rack-Mounting and Servicing

To prevent bodily injury when mounting or servicing this unit in a rack, you must take special precautions to ensure that the system remains stable. The following guidelines are provided to ensure your safety:

- This unit should be mounted at the bottom of the rack if it is the only unit in the rack.
 - When mounting this unit in a partially filled rack, load the rack from the bottom to the top with the heaviest component at the bottom of the rack.
 - If the rack is provided with stabilizing devices, install the stabilizers before mounting or servicing the unit in the rack.
-

Step 1

Slide the power supply end of the chassis onto the bottom-support rails that are installed on the rack.

Be sure that the sides of the chassis by the power supplies clips into the chassis stops on the bottom-support rails and the front-mount brackets come in contact with the rack (see the following figure).

Note If the bottom-support rails are extended a long distance, they can bend outwards slightly when you install the chassis and the chassis stops at the far end of the rails might not fit into the end of the chassis. If this happens, press the side rails toward the sides of the chassis so that the chassis stops can go inside the chassis and hold it in place on the rack.

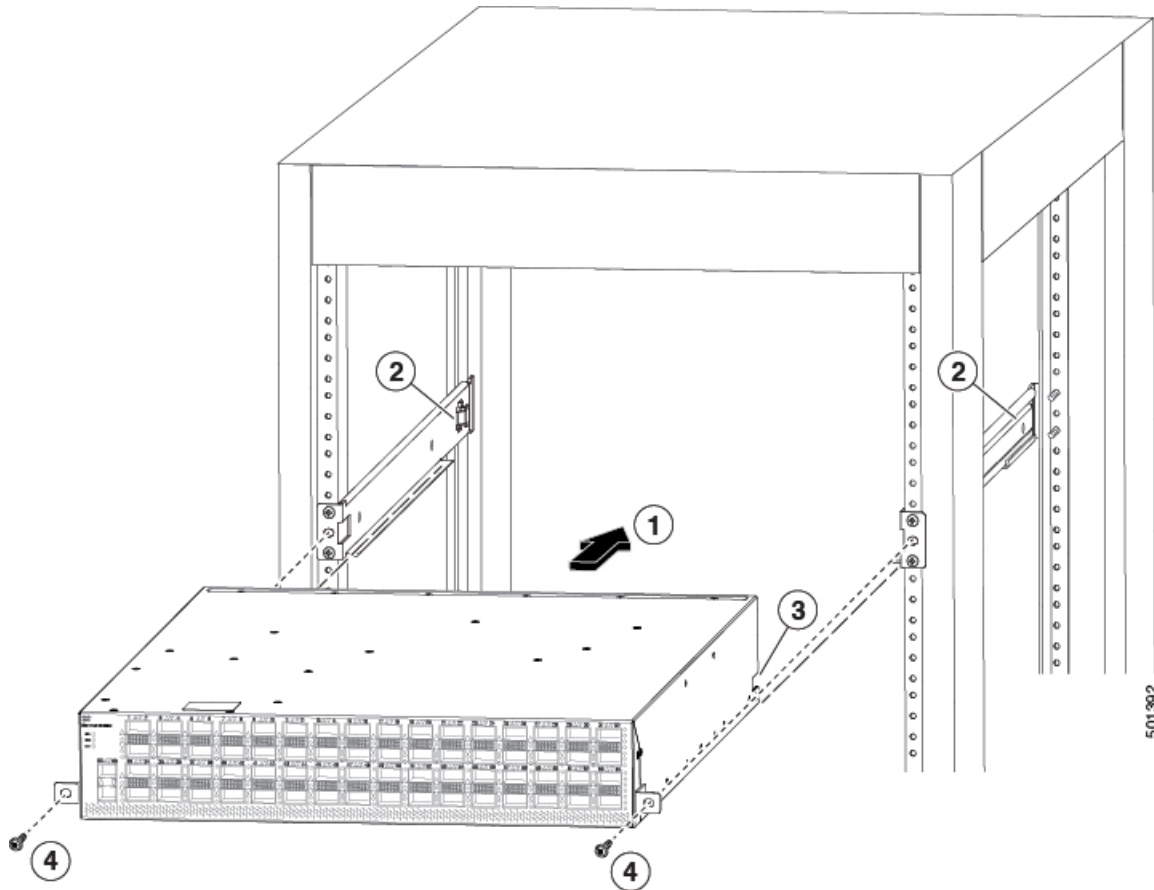

1	Slide the power-supply end of the chassis onto the bottom-support rails so that the chassis locks onto the chassis stops at the end of the rails.	3	Receiving hole on each side of the chassis for the chassis stops on the bottom-support rails.
2	Chassis stops for holding the chassis (positioned by the aisle required for the fan and power supply modules).	4	Customer-supplied rack-mount screw (M6 x 10 mm screw or other screw appropriate for the rack) used to secure each side of the chassis to the rack.

Step 2 Use a customer-supplied rack-mount screw (an M6 x 10 mm screw or other appropriate screw for the rack) to attach each of the two mounting brackets on the chassis to the rack and tighten each screw to the appropriate torque setting for the screw (for M6 x 10 mm screws, use 40 in-lbs [4.5 N·m] of torque).

Installing the Airflow Vent NXA-ACC-BAV3

The airflow vent bracket (NXA-ACC-BAV3) is required for NEBS (Network Equipment-Building System) compliance.



Note An electrical conducting path shall exist between the product chassis and the metal surface of the enclosure or rack in which it is mounted or to a grounding conductor. Electrical continuity shall be provided by using thread-forming type mounting screws that remove any paint or non-conductive coatings and establish a metal-to-metal contact. Any paint or other non-conductive coatings shall be removed on the surfaces between the mounting hardware and the enclosure or rack. The surfaces shall be cleaned and an antioxidant applied before installation.



Note You supply the 10-32 or 12-24 screws to mount the vent bracket and airflow sleeve.

Before you begin

- Verify that your shipment is complete.
- Install your rack in a secure location.

SUMMARY STEPS

1. Insert the vent bracket and attach it as follows:

DETAILED STEPS

Insert the vent bracket and attach it as follows:

- a) Holding the vent bracket (NXA-ACC-BAV3), position it in front and above the switch (see item 1 in the following figure).
- b) Holding the vent bracket level, insert screws (12-24 or 10-32, depending on the rack type) in each of the front rack-mount flanges (using a total of two screws) and into the cage nuts or threaded holes in the vertical rack-mounting rails (see item 2 in the following figure).

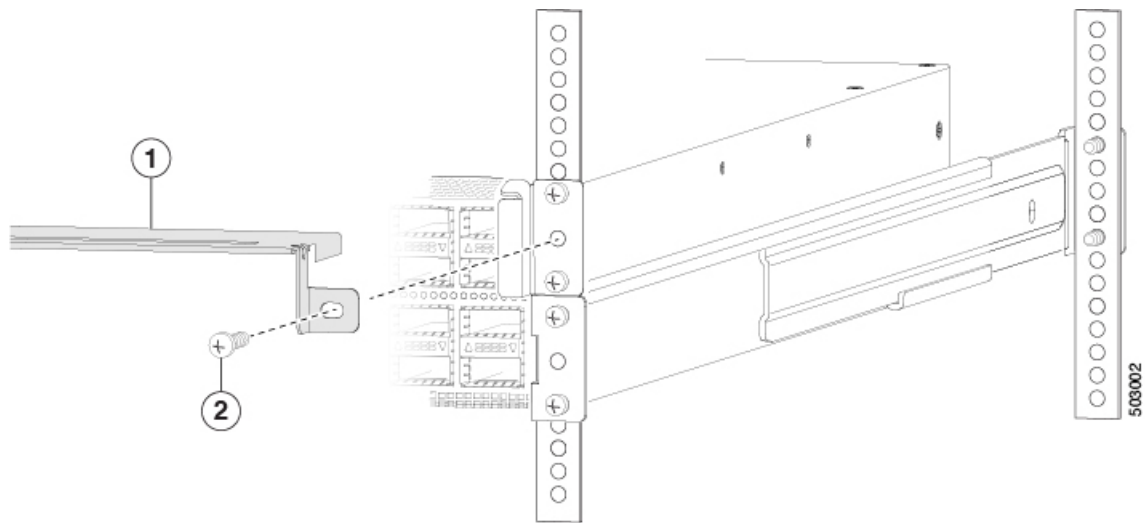

- c) Tighten the 10-32 screws to 20 in-lb (2.26 N·m) or tighten the 12-24 screws to 30 in-lb (3.39 N·m).

Grounding the Chassis

The switch chassis is automatically grounded when you properly install the switch in a grounded rack with metal-to-metal connections between the switch and rack.



Note An electrical conducting path shall exist between the product chassis and the metal surface of the enclosure or rack in which it is mounted or to a grounding conductor. Electrical continuity shall be provided by using thread-forming type mounting screws that remove any paint or non-conductive coatings and establish a metal-to-metal contact. Any paint or other non-conductive coatings shall be removed on the surfaces between the mounting hardware and the enclosure or rack. The surfaces shall be cleaned and an antioxidant applied before installation.

You can also ground the chassis, which is required if the rack is not grounded, by attaching a customer-supplied grounding cable. Attach the cable to the chassis grounding pad and the facility ground.



Warning Statement 1024—Ground Conductor

This equipment must be grounded. To reduce the risk of electric shock, never defeat the ground conductor or operate the equipment in the absence of a suitably installed ground conductor. Contact the appropriate electrical inspection authority or an electrician if you are uncertain that suitable grounding is available.



Warning Statement 1046—Installing or Replacing the Unit

To reduce risk of electric shock, when installing or replacing the unit, the ground connection must always be made first and disconnected last.

Before you begin

Before you can ground the chassis, you must have a connection to the earth ground for the data center building.

- Step 1** Use a wire-stripping tool to remove approximately 0.75 inch (19 mm) of the covering from the end of the grounding wire. We recommend 6-AWG wire for the U.S. installations.
- Step 2** Insert the stripped end of the grounding wire into the open end of the grounding lug. Use a crimping tool to crimp the lug to the wire, see the following figure. Verify that the ground wire is securely attached to the grounding lug by attempting to pull the wire out of the crimped lug.

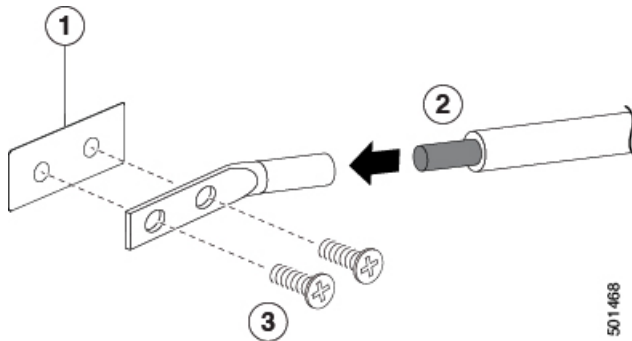

1	Chassis grounding pad	3	2 M4 screws are used to secure the grounding lug to the chassis
2	Grounding cable, with 0.75 in. (19 mm) of insulation that is stripped from one end, which is inserted into the grounding lug and crimped in place		

- Step 3** Secure the grounding lug to the chassis grounding pad with two M4 screws, see the previous figure. Tighten the screws to 11 to 15 in-lb (1.24 to 1.69 N·m) of torque.
- Step 4** Prepare the other end of the grounding wire and connect it to the facility ground.

Starting the Switch

You start the switch by connecting it to its dedicated power source. If you need $n+1$ redundancy, you must connect each of the power supplies to one or two power sources. If you need $n+n$ redundancy, you must connect each power supply in a switch to a different power source.



Note This equipment is designed to boot up in less than 30 minutes, dependent on its neighboring devices being fully up and running.

Before you begin

- The switch must be installed and secured to a rack or cabinet.
- The switch must be adequately grounded.
- The rack must be close enough to the dedicated power source so that you can connect the switch to the power source by using a designated power cables.
- You have the designated power cables for the power supplies that you are connecting to the dedicated power sources.



Note Depending on the outlet receptacle on your AC power distribution unit, you might need an optional jumper power cord to connect the switch to your outlet receptacle.

- The switch is not connected to the network (this includes any management or interface connections).
- The fan and power supply modules are fully secured in their chassis slots.

Step 1 For each AC power supply, do the following:

- a) Using the recommended AC power cable for your country or region, connect one end to the AC power supply.
- b) Connect the other end of the power cable to the AC power source.

Step 2 For each HVAC/HVDC power supply, connect it to a power source as follows:

- a) Using the recommended high voltage power cable for your country or region, connect the Anderson Power Saf-D-Grid connector on the power cable to the power receptacle on the power supply. Make sure that the connector clicks when fully pushed into the receptacle.
- b) Connect the other end of the power cable to a power source.
 - When connecting to an HVAC power source, insert the C14 or LS-25 plug in a receptacle for the HVAC power source.
 - When connecting to an HVDC power source, do the following:
 1. Verify that the power is turned off at a circuit breaker for the power source terminals.
 2. Remove the nuts from each of the terminal posts for the power supply.
 3. Place the power cable negative-wire terminal ring on the negative terminal for the power source and secure them with a terminal nut.
 4. Place the power cable positive-wire terminal ring on the positive terminal for the power source and secure them with a terminal nut.
 5. Place the power cable ground-wire terminal ring on the ground terminal for the power source and secure them with a terminal nut.
 6. If there is a safety cover for the power source terminals, place and secure it over the terminals to avoid an electrical shock hazard.
 7. Turn on the power at the power source circuit breaker.

- Step 3** For each DC power supply, do the following:
- Turn off the circuit breaker for the power source to avoid an electrical shock hazard.
 - Verify that the power cable wires from the power source are connected to a connector block.
 - Insert the connector block into the receptacle on the power supply. Make sure that the connector block clicks when fully inserted in the receptacle and does not pull out.
 - If there is a safety cover for the terminals, place and secure it over the terminals to avoid an electrical shock hazard.
 - Turn on the power at the circuit breaker for the DC power source.
- Step 4** Verify that the power supply LED is on and green.
- Step 5** Listen for the fans; they should begin operating when the power supply is powered.
- Step 6** After the switch boots, verify that the following LEDs are lit:
- On the fan modules, the Status (STA or STS) LED is green.
If a fan module Status LED is not green, try reinstalling the fan module.
 - After initialization, the switch chassis Status (labeled as STA or STS) LED is green.
- Step 7** Verify that the system software has booted and the switch has initialized without error messages.
- A setup utility automatically launches the first time that you access the switch and guides you through the basic configuration. For instructions on how to configure the switch and check module connectivity, see the appropriate Cisco Nexus 9000 Series configuration guide.
-



CHAPTER 4

Connecting the Switch to the ACI Fabric

- [ACI Fabric Topology, on page 37](#)
- [Preparing to Connect to Other Devices, on page 38](#)
- [Connecting Leaf Switches to APICs, on page 39](#)
- [Connecting Leaf Switches to Spine Switches, on page 40](#)
- [Installing a Gigabit Ethernet module \(GEM\), on page 42](#)
- [Virtual Port Channel Migration - Migration of Nodes from a First-Generation Switch to a Second-Generation Switch, on page 42](#)
- [Setting Up an Optional Console Interface, on page 43](#)
- [Setting Up an Optional Management Connection, on page 44](#)
- [Optic Transceiver Removal Using the Optics Extraction Tool , on page 44](#)
- [Maintaining Transceivers and Optical Cables, on page 45](#)

ACI Fabric Topology

The ACI fabric topology includes the following major components:

- Application Centric Infrastructure Controller (APIC) appliance (cluster of APICs)
- Leaf switches (for switch compatibility, please see the [data sheets](#)).
- Spine switches (for switch compatibility, please see the [data sheets](#)).

For additional information, please see the [Cisco APIC Installation, Upgrade, and Downgrade Guide](#).



Note To prevent sub-optimal forwarding between endpoints, connect every leaf switch in the fabric to every spine switch in the same fabric.

As shown in the following figure, each APIC is connected to one or two leaf switches and each leaf switch should be connected to every spine switch in the same fabric.

Figure 2: Connections Between APIC Clusters, Leaf Nodes, and Spine Nodes

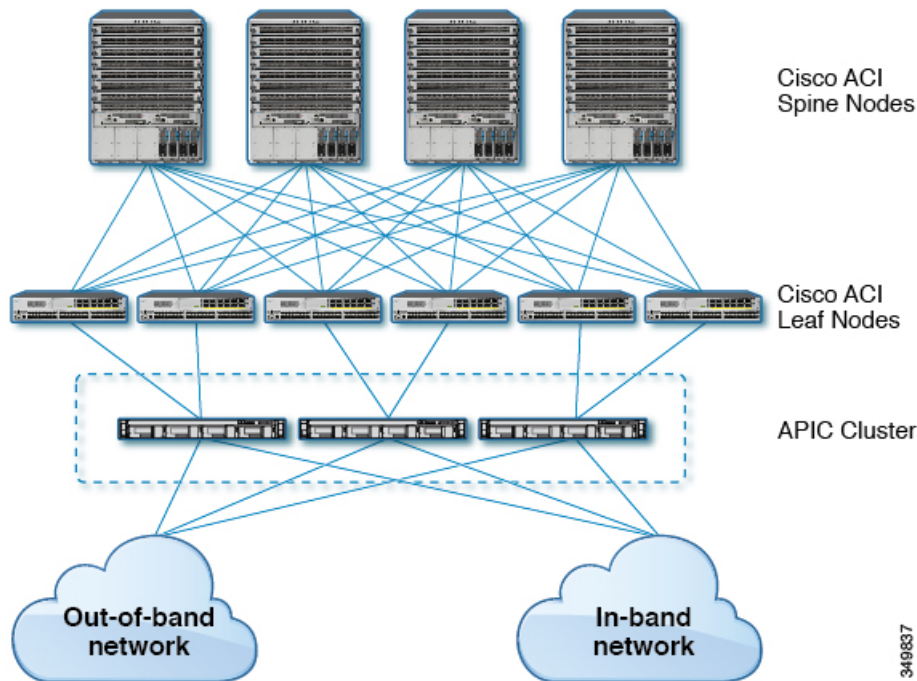

Preparing to Connect to Other Devices

When preparing to connect the fabric devices, consider the following for each type of interface, and gather all of the required equipment before making the connections:

- Cabling type required for each interface type
- Distance limitations for each signal type
- Additional interface equipment required



Note When running power and data cables in overhead or subfloor cable trays, we strongly recommend that you locate power cables and other potential noise sources as far away as practical from network cabling that terminates on Cisco equipment. In situations where long parallel cable runs cannot be separated by at least 3.3 feet (1 meter), we recommend that you shield any potential noise sources by housing them in a grounded metallic conduit.

The optical transceivers that are not already assembled to their cables come separate from their cables. To prevent these transceivers and their cables from being damaged, we recommend that you keep the transceivers disconnected from their cables when installing them in ports and then insert the optical cable into the transceiver. When removing transceivers from ports, remove their cables before removing the transceivers.

To maximize the effectiveness and life of your transceivers and optical cables, do the following:

- Wear an ESD-preventative wrist strap that is connected to an earth ground whenever handling transceivers. The switch is typically grounded when you install transceivers and provides an ESD port to which you

can connect your wrist strap. If you cannot find an ESD port, connect the wrist strap to an earth ground (such as the grounding connection for the chassis).

- Do not remove or insert a transceiver more often than necessary. Repeated removals and insertions can shorten its useful life.
- Keep the transceivers and fiber-optic cables clean and dust free to maintain high signal accuracy and to prevent damage to the connectors. Attenuation (loss of light) increases with contamination and should be kept below 0.35 dB.
 - Clean these parts before installing them to prevent dust from scratching the fiber-optic cable ends.
 - Clean the connectors regularly; the required frequency of cleaning depends upon the environment. In addition, clean connectors if they are exposed to dust or accidentally touched. Both wet and dry cleaning techniques can be effective; refer to your site's fiber-optic connection cleaning procedures.
 - Do not touch the ends of connectors. Touching the ends can leave fingerprints and cause other contamination.
- Inspect routinely for dust and damage. If you suspect damage, clean and then inspect fiber ends under a microscope to determine if damage has occurred.

Connecting Leaf Switches to APICs

You must downlink one or two (recommended for redundancy) Cisco Nexus 9300 platform ACI-mode leaf switches to each Application Policy Infrastructure Controller (APIC) in your ACI fabric. The type of virtual interface card (VIC) installed on the APIC determines the types of interface cables that you can use to connect the leaf switches to the APICs.

- The **VIC 1225T** module supports copper connectors, copper cables, and switches with copper downlink ports (such as: Cisco Nexus 93108TC-EX, 93108TC-FX, 93120TX, 93128TX, 9372TX, 9372TX-E, and 9396TX switches).
- The **VIC 1225** module supports optical transceivers, optical cables, and switches with optical downlink ports (such as: Cisco Nexus 93180LC-EX, 93180YC-EX, 93180YC-FX, 9332PQ, 9336C-FX2, 9348GC-FXP, 9372PX, 9372PX-E, 9396PX, and 93600CD-GC switches).
- The **VIC 1455** module supports optical transceivers, optical cables, and switches with optical downlink ports (such as: Cisco Nexus 9336C-FX2, 93180LC-EX, 93180YC-EX, 93180YC-FX, 93240YC=FX2, and 93600CD-GC switches).

Before you begin

The APIC and leaf switches in the fabric must be fully installed in their racks and grounded.

Step 1

Connect an interface cable to one of the two to four ports on the virtual interface card (VIC) installed on the APIC. If the cable is not already assembled to its transceivers, insert the transceiver into the VIC port and then connect the optical interface cable to the transceiver.

- For a **VIC 1225T** 10GBASE-T copper module, use 10GBASE-T cables with RJ-45 connectors.
- For a **VIC 1225** optical module, use one of the following sets of transceivers and cables:

- For a **VIC 1455** SFP28 module, 10-Gigabit only, use one of the following sets of transceivers and cables:
 - Cisco 10GBASE-LR transceivers (SFP-10G-LR) supporting a link length of up to 6.1 miles (10 km)
 - Cisco 10GBASE-SR transceivers (SFP-10G-SR) supporting the following link lengths:
 - Using 2000 MHz MMF (OM3) for up to 984 feet (300 m)
 - Using 4700 MHz MMF (OM4) for up to 1312 feet (400 m)
 - Cisco SFP+ Active Optical Cables (SFP-10G-AOCxM [where x=1, 2, 3, 5, 7, or 10 for lengths in meters])
 - Cisco SFP+ Twinax Cables (SFP-H10GB-CUxM [where x=1, 2, 3, 5, 7, or 10 for lengths in meters])

Note The VIC 1455 has 4 ports, port-1, port-2, port-3, and port-4 from left to right.

- All ports must have the same speed, either 10-Gigabit or 25-Gigabit.
- Port-1 and port-2 is one pair, corresponding to eth2-1 on APIC and port-3 and port-4 is another pair, corresponding to eth2-2 on APIC. Only one connection is allowed for each pair. For example, you can connect one cable to either port-1 or port-2, and connect another cable to either port-3 or port-4 (**please do not connect two cables on any pair**).

To determine which transceivers, adapters, and cables support this switch, see the [Cisco Transceiver Modules Compatibility Information](#) document.

To see the transceiver specifications and installation information, see [Transceiver Module Installation Guides](#).

Step 2 Connect the other end of the interface cable to a downlink port on a leaf switch.

- For a Cisco 10GBASE-LR or -SR transceiver and cable, insert the transceiver into a downlink optical port on a leaf switch before connecting the cable to the transceiver.
- For Cisco SFP+ Active Optical Cables, insert the transceiver on the cable into a downlink optical port on a leaf switch.
- For a 10GBASE-T copper cable, insert the RJ-45 connector on the cable into a downlink BASE-T port on a leaf switch.

Note To determine which transceivers, adapters, and cables support this switch, see the [Cisco Transceiver Modules Compatibility Information](#) document.

Connecting Leaf Switches to Spine Switches

For optimal forwarding between endpoints, you must connect each leaf switch to every spine switch in the same ACI fabric.

To determine which transceivers, adapters, and cables support this switch, see the [Cisco Transceiver Modules Compatibility Information](#) document.

To see the transceiver specifications and installation information, see [Transceiver Module Installation Guides](#).

**Warning Statement 1055**—Class 1/1M Laser

Invisible laser radiation is present. Do not expose to users of telescopic optics. This applies to Class 1/1M laser products.

**Warning Statement 1056**—Unterminated Fiber Cable

Invisible laser radiation may be emitted from the end of the unterminated fiber cable or connector. Do not view directly with optical instruments. Viewing the laser output with certain optical instruments, for example, eye loupes, magnifiers, and microscopes, within a distance of 100 mm may pose an eye hazard.

Before you begin

- The leaf and spine switches in the fabric (such as: N9k-C9364C, N9K-C9332C, and N9K-C9316D-GX) must be fully installed in their racks and grounded.
- If there are modular switches in the fabric, their ACI-mode line cards must already be installed. The line cards can be of the following types:
 - 36-port 40-Gigabit (such as: N9K-X9736PQ)
 - 32-port 100-Gigabit (such as: N9K-X9732C-EX)
 - 36-port 100-Gigabit (such as: N9K-X9736C-FX)
 - 16-port 400-Gigabit (such as: N9K-X9716D-GX)



Note You cannot include NX-OS line cards in the same chassis when running in ACI mode.



Note Multiple uplinks from a leaf switch to a spine switch is supported. A symmetrical topology is recommended so that all devices have equal access to resources.

- Step 1** For the transceivers with removable cables, make sure that the transceivers are separated from their interface cables.
- Step 2** Insert the appropriate transceiver into an active uplink port on the leaf switch.
- Step 3** Insert the same type of transceiver in the spine switch port on the line card.
- Step 4** For transceivers with removable cables, insert the interface cable into the open end of each of those transceivers.

- Step 5** Repeat Steps 1 through 4 for each spine switch in the ACI fabric.
The leaf switch is connected to each spine switch in the ACI fabric.
- Step 6** Repeat Steps 1 through 5 for each leaf switch in the ACI fabric.
Each leaf switch in the ACI fabric is connected to each spine switch in the network,

The fabric automatically implements Equal Cost Multi-Pathing (ECMP) and enables all links. You do not need to configure the links.

Installing a Gigabit Ethernet module (GEM)

- Step 1** Clear the switch's current configuration by using the `setup-clean-config` command.
- Step 2** Power off the switch by disconnecting the power.
- Step 3** Replace the current GEM card with the new GEM card.
- Step 4** Power on the switch.
-

Virtual Port Channel Migration - Migration of Nodes from a First-Generation Switch to a Second-Generation Switch

Initially the fabric is configured with vPCs between two first-generation switches. Traffic flows are designed so that only these vPCs are used for data traffic. Now that you want to migrate both of the first-generation switches to second-generation switches, the following steps are required.

For this procedure, vPC primary and vPC secondary are first generation switches in vPC pair, sending traffic as described above.

To determine which transceivers, adapters, and cables support this switch, see the [Cisco Transceiver Modules Compatibility Information](#) document.

To see the transceiver specifications and installation information, see [Transceiver Module Installation Guides](#).

Before you begin

You have two first-generation Cisco Nexus 9000 Series switches comprising a virtual port channel (vPC). You are migrating to two second-generation Cisco Nexus 9000 Series switches using the same cables.

First-generation Cisco Nexus 9000 Series switches include those switches that do not contain an EX or an FX in the PID (product identification).

Second-generation Cisco Nexus 9000 Series switches include those switches that have an EX or an FX in the PID.

Move any APIC controllers that are connected to the migrating vPC first-generation switches to any other switches in the fabric and wait for the APIC cluster to become "Fully Fit".

-
- Step 1** From the APIC GUI, perform the **Remove From Controller** operation for vPC secondary. The switch is clean rebooted by the APIC. Wait for about 10 minutes for this operation to finish. This action prompts all traffic to use the other first-generation switch for data traffic. Disconnect the cabling from vPC secondary.
- Step 2** Uninstall the first-generation switch by reversing the order of the steps in the Installing the Switch Chassis section, of the switch specific Hardware Installation Guide.
- Step 3** Install the second-generation switch by following the steps in the Installing the Switch Chassis section, of the switch specific Hardware Installation Guide.
- Step 4** Connect the loose cabling that you removed from the first-generation switch, to the same ports on the second-generation switch.
- Step 5** Now you register the new second-generation switch with the APIC. Register the new node with the same node name and node ID. This switch becomes part of the fabric. Policies are pushed to the new switch and the vPC legs are kept down since there is a mismatch of generation switches. At this point, vPC primary continues to send the data traffic.
- Step 6** From the APIC GUI, perform the **Remove From Controller** operation for vPC primary. This switch is clean rebooted by the APIC.
- Wait for about 10 minutes for this operation to finish. The vPC leg on the second-generation switch, which was kept down earlier comes up. This action prompts all traffic to move to the new second-generation switch. Please note the vPC ports on the new second-generation switch will come up in about 10 to 22 seconds when STP is disabled for the deployed VLANs on the remote devices, and there will be traffic drops in the range of 10 to 40 seconds, depending upon the flows in the fabric. When STP is enabled on the VLANs on the remote devices, the traffic loss will be in the range of 40 to 75 seconds, depending upon the flows in the fabric.
- Step 7** Disconnect the cabling from the other first-generation switch.
- Step 8** Uninstall the first-generation switch, like you did in step 2.
- Step 9** Install the second-generation switch, like you did in step 3.
- Step 10** Connect the loose cabling, like you did in step 4.
- Step 11** Register the new second-generation switch with the APIC. Register the new node with the same node name and node ID. This switch becomes part of the fabric. Policies are pushed to the new switch and the vPC legs comes up and starts passing traffic.
-

Setting Up an Optional Console Interface

You can optionally set up a console interface for performing the initial configuration of the switch. To do this, use the interface cable provided in the accessory kit to connect the switch to your console device. You can connect the console port on the switch to a modem. If you do not connect it to a modem, make the connection either before powering up the switch or after completing the boot process for the switch.

Before you begin

The console device must support VT100 terminal emulations and asynchronous transmissions.

-
- Step 1** Configure the terminal emulator program to match each of the following default port characteristics:
- 9600 baud

- 8 data bits
- 1 stop bit
- No parity

Step 2 Insert the RJ-45 connector on the interface cable found in the accessory kit into the RS-232 port on the switch and insert the DB-9 connector on the other end of the cable to the serial port on the console device.

What to do next

You can now perform the initial configuration for the switch (see the *Cisco ACI Getting Started Guide*).

Setting Up an Optional Management Connection

You can optionally set up an out-of-band management connection for monitoring and troubleshooting purposes. To do this, depending on your switch, you connect either the RJ-45 management port or the SFP management port on the switch to an external hub, switch, or router.

Before you begin

To prevent an IP address conflict, you must complete the initial configuration for the switch and establish an IP address before you create the management connection.

Step 1 Connect the interface cable to a management port on the switch.

Step 2 Connect the other end of the cable to an external hub, switch, or router.

Optic Transceiver Removal Using the Optics Extraction Tool

You use both ends of the optics extraction tool in this procedure. You use the wide end for releasing the bale latch, and the narrow end for removing the transceiver module.

Before you begin

Ensure that before you handle any switch components, you are wearing a grounded electrostatic discharge (ESD) strap. To ground the strap, attach it directly to earth ground or to a grounded rack or chassis. There must be a metal-to-metal connection to earth ground.

Step 1 Remove the fiber-optic cables from the transceiver module before removing the transceiver module.

Step 2 Use the wide side of the optics extraction tool to release the bale latch (see the following image).

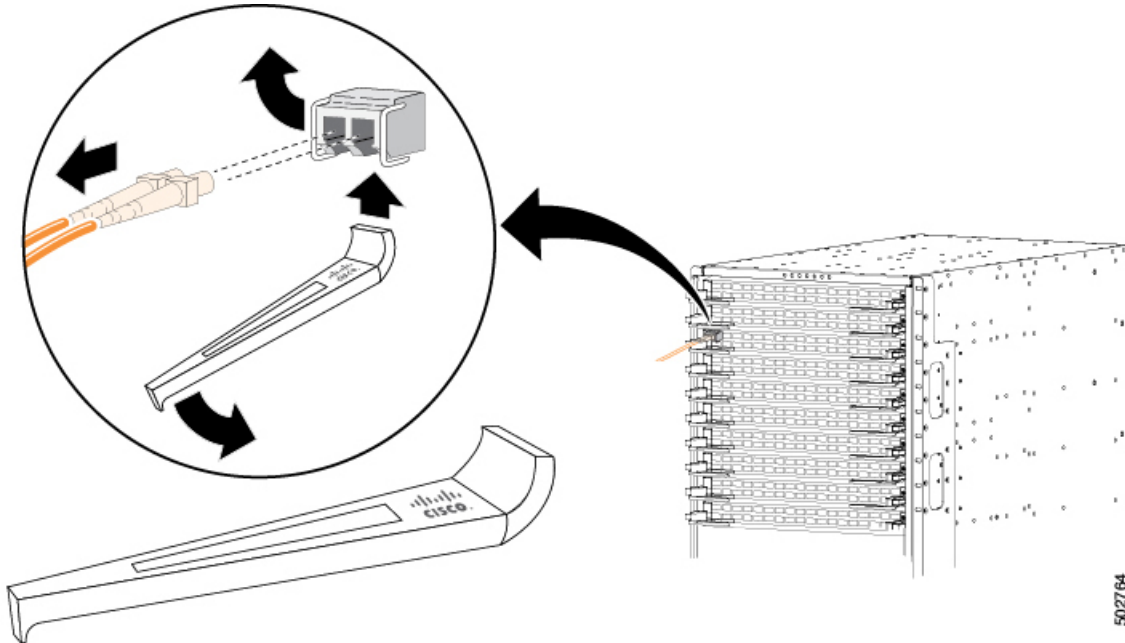

Step 3 Use the narrow end of the optics extraction tool to carefully remove the transceiver module (see the following

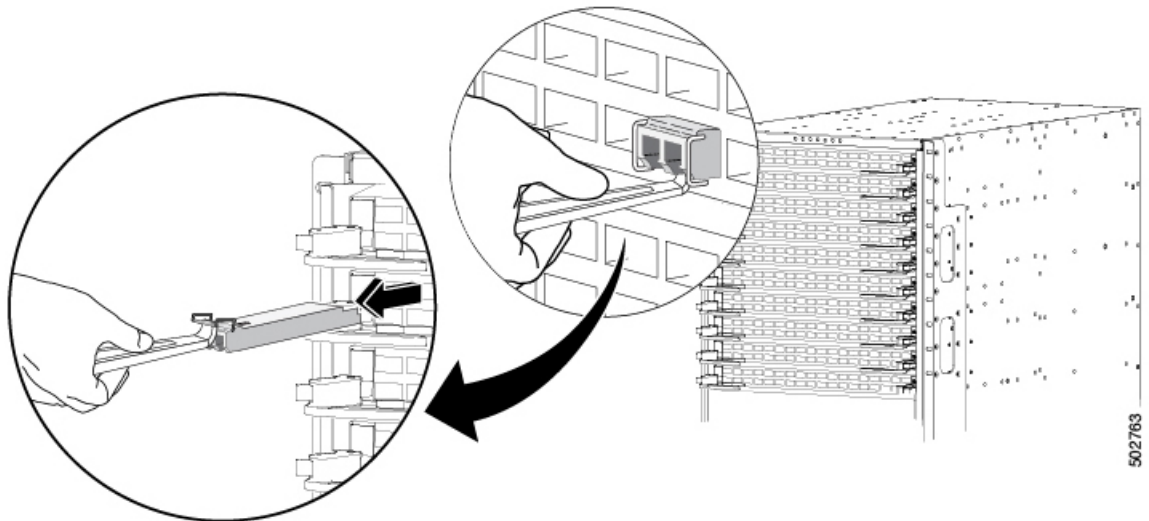

image).

Step 4 Place the transceiver module in an antistatic bag or other protective environment.

Maintaining Transceivers and Optical Cables

Transceivers and fiber-optic cables must be kept clean and dust free to maintain high signal accuracy and prevent damage to the connectors. Contamination increases attenuation (loss of light) and should be below 0.35 dB.

Consider the following maintenance guidelines:

- Transceivers are static sensitive. To prevent ESD damage, wear an ESD-preventative wrist strap that is connected to the grounded chassis.
- Do not remove and insert a transceiver more often than is necessary. Repeated removals and insertions can shorten its useful life.
- Keep all optical connections covered when not in use. Clean them before using to prevent dust from scratching the fiber-optic cable ends.
- Do not touch the ends of connectors. Touching the ends can leave fingerprints and cause other contamination.
- Clean the connectors regularly; the required frequency of cleaning depends upon the environment. In addition, clean connectors if they are exposed to dust or accidentally touched. Both wet and dry cleaning techniques can be effective; refer to the fiber-optic connection cleaning procedures for your site.
- Inspect routinely for dust and damage. If you suspect damage, clean and then inspect fiber ends under a microscope to determine if damage has occurred.



CHAPTER 5

Replacing Components

- [Replacing a Fan Module During Operations, on page 47](#)
- [Replacing a Power Supply Module, on page 48](#)

Replacing a Fan Module During Operations

All fan and power supply modules must have the same airflow direction or else an error can occur with the switch overheating and shutting down. You can determine the airflow direction of a fan module by the color of the stripe on the front of the module. If the fan module has a blue stripe for port-side exhaust airflow, the power supplies must have blue coloring for the same airflow direction. If the fan module has a burgundy stripe for port-side intake airflow, the power supplies must have burgundy coloring for the same airflow direction. To avoid over heating the switch, make sure that the fan modules are positioned in one of the following ways:

- For port-side exhaust airflow with blue coloring, position the fan modules in a cold aisle.
- For port-side intake airflow with burgundy coloring, position the ports in a cold aisle.

Before you begin

Before you can replace a fan module, ensure that both of the following conditions exist:

- The replacement fan module must have the same airflow direction as the other modules in the chassis.

If you must replace the fan module during operations and both of the above conditions are not met, leave the fan module that you need to replace in the chassis to preserve the designed airflow until you have the required module.

Step 1 Remove the fan module that you need to replace as follows:

- a) Place the removed module on an antistatic surface or in an antistatic bag. If possible, repack the module in its packing materials for safe shipping or storage.

Step 2 Follow these steps to replace the missing fan module within two minutes to avoid a shutdown.

- a) Remove the replacement fan module from its packing materials and place it on an antistatic surface.

Hold the module by its handle and do not touch the electrical connectors on its backside. Also, to protect the electrical connectors, avoid letting them come in contact with anything other than the electrical connectors inside the chassis.

- b) Position the fan module in front of the open fan slot (be sure that the backside of the module with the electrical connectors is positioned to enter the slot first) and slide the module all the way into the chassis until its front side comes in contact with the chassis. For the last 0.2 inches (0.5 cm), carefully mount the module onto the chassis connectors by pushing more firmly, but do not force the module if it does not move further (excessive force can damage the connectors).

Note If you are not able to push the module all the way into the slot, carefully slide the module out of the slot and check its electrical connectors for damage. If damaged, contact Cisco Technical Assistance for help. If undamaged, repeat this step to reinstall the module.

- c) Verify that the STS LED turns on and becomes green.

If the STS LED does not turn on, slide the module out of the chassis, and visually check the electrical connectors on the back side of the chassis for damage. If damaged, contact Cisco Technical Assistance for help. If undamaged, repeat the previous step to reinstall the module.

Replacing a Power Supply Module

The switch requires two power supplies for redundancy. With one power supply providing the necessary power for operations, you can replace the other power supply during operations so long as the new power supply has the same airflow direction as the other modules in the chassis.

You can replace a power supply with another supported power supply that has the same power source type and the same wattage rating as the other installed power supply. Additionally, the airflow direction of the power supply must match or conform to the airflow direction of the installed fan modules. For the airflow direction used by the switch, see the coloring of the fan modules.

Removing an AC Power Supply

To remove an AC power supply, you must first disconnect the power cable and then remove the module from the chassis.

Before you begin

- To replace a power supply during operations, you must have a functioning power supply providing power to the switch while you replace the other power supply. If there is only one power supply installed in the switch and you need to replace it, install the new power supply in the open slot and power it up before removing the original power supply.
- Ensure that the chassis is grounded. For grounding instructions, see [Grounding the Chassis, on page 32](#).

Step 1 Pull the power cord out from the power receptacle on the power supply to be removed and verify that the LED turns off.

Note The LED might be on and amber colored to indicate that the input power has been disconnected.

Step 2 Remove the power supply from the chassis by pushing and holding its thumb latch to the left and pulling the power supply part way out of the chassis.

- Step 3** Place your other hand under the power supply to support it while you slide it out of the chassis.
Either place the power supply on an antistatic surface or pack it in its packing materials.
- Step 4** If the power supply slot is to remain empty, install a blank power supply filler panel (part number N2200-P-BLNK).
-

What to do next

You are ready to install the replacement power supply.

Removing an HVAC/HVDC Power Supply

You can remove one power supply while the other one provides power to the switch.

To disconnect the power supply from its power cables, you must shut off the power from the power source and then either disconnect a connector for the power cables or release each of three cables from the power supply (requires a standard screw driver).

- Step 1** Turn off the circuit breaker for the power feed to the power supply that you are replacing.
Be sure that the LEDs turn off on the power supply that you are removing.
- Step 2** Remove the power cable from the power supply by pressing the tab on the top of the Anderson Power SAF-D-Grid connector and pull the cable and connector out of the power supply.
- Step 3** Grasp the power supply handle while pressing the release latch towards the power supply handle.
- Step 4** Place your other hand under the power supply to support it while you slide it out of the chassis.
- Caution** Do not touch the electrical connectors on the back side of the module and prevent anything else from coming into contact with and damaging the connectors.
-

What to do next

You are ready to install an HVAC/HVDC power supply in the open slot.

Removing a DC Power Supply

You can remove one power supply while the other one provides power to the switch.

To disconnect the power supply from its power cables, you must shut off the power from the power source and then either disconnect a connector for the power cables or release each of three cables from the power supply (requires a standard screw driver).

- Step 1** Turn off the circuit breaker for the power feed to the power supply that you are replacing.
Be sure that the LEDs turn off on the power supply that you are removing.
- Step 2** Remove the power cable from the power supply by doing the following:

- To remove an orange power cable connector from a 48-V DC power supply, do the following:
 - a. Push the orange plastic button on the top of the connector block inward toward the power supply.
 - b. Pull the connector block out of the power supply.

Step 3 Grasp the power supply handle while pressing the release latch towards the power supply handle.

Step 4 Pull the power supply out of the bay.

What to do next

You are ready to install a DC power supply in the open slot.

Installing an AC Power Supply

You can replace one power supply while the other one provides power to the switch.

Before you begin

- The power supply that you are installing must be capable of using the same airflow direction as the fan trays installed in the same switch and it must use the same type of power source as the other power supply installed in the same switch (do not mix AC and DC power supplies in the same switch).



Note If the power supply that you are replacing has a different color handle than the replacement power supply, verify that it has or will have the same airflow direction as the other modules in the switch.

- An AC power source must be within reach of the power cable that will be used with the replacement power supply. If you are using $n+n$ power redundancy, there must be a separate power source for each power supply installed in the chassis. Otherwise, only one power source is required.
- There must be an earth ground connection to the chassis that you are installing the replacement module. Typically, the chassis is grounded by its metal-to-metal connection with a grounded rack. If you need to ground the chassis, see [Grounding the Chassis, on page 32](#).

Step 1 Holding the replacement power supply with one hand underneath the module and the other hand holding the handle, turn the power supply so that its release latch is on the side and align the back end of the power supply (the end with the electrical connections) to the open power supply slot before carefully sliding the power supply all the way into the slot until it clicks into place.

Note If the power supply does not fit into the open slot, turn the module over before sliding it carefully into the open slot.

Step 2 Test the installation by trying to pull the power supply out of the slot without using the release latch.

If the power supply does not move out of place, it is secured in the slot. If the power supply moves, carefully press it all the way into the slot until it clicks in place.

Step 3 Attach the power cable to the electrical outlet on the front of the power supply.

Step 4 Make sure that the other end of the power cable is attached to the appropriate power source for the power supply.

Note Depending on the outlet receptacle on your power distribution unit, you might need the optional jumper cable to connect the switch to your outlet receptacle.

Step 5 Verify that the power supply is operational by making sure that the power supply LED is green.

Installing an HVAC/HVDC Power Supply

You can replace one power supply while the other one provides power to the switch.



Note If the power supply that you are replacing has a different color handle than the replacement power supply, verify that it has or will have the same airflow direction as the other modules in the switch.

Before you begin

- If you are using DC power for the replacement power supply, the circuit breaker for the power feed to the power supply that you are replacing must be turned off.
 - If you are using $n+n$ power redundancy, there must be a separate power source for each power supply installed in the chassis (power sources must be of the same type—do not mix AC and DC power sources for the same switch). Otherwise, only one power source is required.
 - There must be an earth ground connection to the chassis that you are installing the replacement module. Typically, the chassis is grounded by its metal-to-metal connection to a grounded rack. If you need to ground this chassis by another means, see [Grounding the Chassis, on page 32](#).
-

Step 1 Holding the replacement power supply with one hand underneath the module and the other hand holding the handle, turn the power supply so that its release latch is on the side and align the back end of the power supply (the end with the electrical connections) to the open power supply slot before carefully sliding the power supply all the way into the slot until it clicks into place.

Note If the power supply does not fit into the open slot, turn the module over before sliding it into the open slot.

Step 2 Test the installation by trying to pull the power supply out of the slot without using the release latch.

If the power supply does not move out of place, it is secured in the slot. If the power supply moves, carefully press it all the way into the slot until it clicks in place.

Step 3 If the DC power cables and a grounding cable are already connected to an electrical connector block, insert the block into the power receptacle on the power supply.

If the electrical cables have not been connected to the electrical connector block, wire them as described in [Wiring a 48 V DC Electrical Connector Block, on page 52](#).

Step 4 Make sure that the other end of the power cable is connected to the appropriate power source for the power supply.

Step 5 If using a DC power source, turn on the circuit breaker for the DC power source connected to the power supply.

Step 6 Verify that the power supply is operational by making sure that the power supply LED is green.

Installing a DC Power Supply

You can replace one power supply while the other one provides power to the switch.

Before you begin

- The circuit breaker for the DC power source for the power supply must be turned off.
- The power supply that you are installing must be capable of using the same airflow direction as the fan trays installed in the same switch
- A DC power source must be within reach of the power cable that will be used with the replacement power supply. If you are using $n+n$ power redundancy, there must be a separate power source for each power supply installed in the chassis (do not mix AC and DC power sources for the same switch). Otherwise, only one power source is required.
- There must be an earth ground connection to the chassis that you are installing the replacement module. Typically, the chassis is grounded by its metal-to-metal connection to a grounded rack. If you need to ground this chassis by another means, see [Grounding the Chassis, on page 32](#).
- We recommend 8-AWG wire for DC installation in the U.S.
- All DC power supplies have reverse polarity protection. When you inadvertently connect the input power (+) to the DC PSU's – terminal and the input power – to the DC PSU's (+) terminal, the PSU will not be damaged and will operate fine after the input power feeds are correctly wired.

Step 1 Holding the replacement power supply with one hand underneath the module and the other hand holding the handle, turn the power supply so that its release latch is on the side and align the back end of the power supply (the end with the electrical connections) to the open power supply slot before carefully sliding the power supply all the way into the slot until it clicks into place.

Note If the power supply does not fit into the open slot, turn the module over before carefully sliding it into the open slot.

Step 2 If the DC power cables and a grounding cable are already connected to an electrical connector block, insert the block into the power receptacle on the power supply.

If the electrical cables have not been connected to the electrical connector block, wire them as described in [Wiring a 48 V DC Electrical Connector Block, on page 52](#).

Step 3 Turn on the circuit breaker for the DC power source connected to the power supply.

Step 4 Verify that the power supply is operational by making sure that the power supply LED is green.

Wiring a 48 V DC Electrical Connector Block

You must connect the ground, negative, and positive DC power cables to a connector block in order to connect the power cables to a 48 V DC power supply.



Note The recommended wire gauge is 8 AWG. The minimum wire gauge is 10 AWG.



Warning Statement 342—Before Connecting to System Power Supply

High touch/leakage current – Permanently connected protective earth ground is essential before connecting to system power supply.



Warning Statement 1024—Ground Conductor

This equipment must be grounded. To reduce the risk of electric shock, never defeat the ground conductor or operate the equipment in the absence of a suitably installed ground conductor. Contact the appropriate electrical inspection authority or an electrician if you are uncertain that suitable grounding is available.

Before you begin

You must turn off the circuit breaker for the DC power cables that you are connecting to prevent electrocution.

- Step 1** Verify that the circuit breaker for the power feed to the replacement power supply is turned off.
- Step 2** Remove the DC power connector block from the power supply by doing the following:
 - a) Push the orange plastic button on the top of the connector block inward toward the power supply.
 - b) Pull the connector block out of the power supply.
- Step 3** Strip 0.6 inches (15 mm) of insulation off the DC wires that you are using.
- Step 4** Orient the connector as shown in the following figure with the orange plastic button on top.

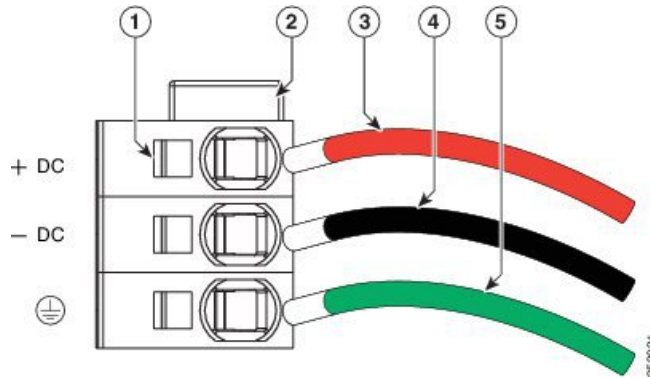

1	Wire retainer lever	4	-48V (-DC) cable
2	Orange plastic button on top of the connector	5	Grounding cable (8 AWG recommended)
3	-48V Return (+DC) cable		

- Step 5** Use a small screwdriver to depress the spring-loaded wire retainer lever on the lower spring-cage wire connector. Insert your green (ground) wire into the aperture and then release the lever.
- Step 6** Use a small screwdriver to depress the spring-loaded wire retainer lever on the middle spring-cage wire connector. Insert your black (DC negative) wire into the aperture and then release the lever.
- Step 7** Use a small screwdriver to depress the spring-loaded wire retainer lever on the upper spring-cage wire connector. Insert your red (DC positive) wire into the aperture and then release the lever.
- Step 8** Insert the connector block back into the power supply. Make sure that your red (DC positive) wire aligns with the power supply label, "+ DC".
- Step 9** Verify that the other ends of the cables are attached to the DC power source and ground. You are then ready to turn on the DC power source.
-



APPENDIX **A**

Rack Specifications

- [Overview of Racks, on page 55](#)
- [General Requirements for Cabinets and Racks, on page 55](#)
- [Requirements Specific to Standard Open Racks, on page 56](#)
- [Requirements Specific to Perforated Cabinets, on page 56](#)
- [Cable Management Guidelines, on page 56](#)

Overview of Racks

You can install the switch in the following types of cabinets and racks, assuming an external ambient air temperature range of 0 to 104°F (0 to 40°C):

- Standard perforated cabinets
- Solid-walled cabinets with a roof fan tray (bottom to top cooling)
- Standard open racks



Note If you are selecting an enclosed cabinet, we recommend one of the thermally validated types, either standard perforated or solid-walled with a fan tray.



Note We do not recommend that you use racks that have obstructions (such as power strips), because the obstructions could impair access to field-replaceable units (FRUs).

General Requirements for Cabinets and Racks

The cabinet or rack must also meet the following requirements:

- Standard 19-inch (48.3 cm) (two- or four-post EIA cabinet or rack, with mounting rails that conform to English universal hole spacing per section 1 of ANSI/EIA-310-D-1992). For more information, see [Requirements Specific to Perforated Cabinets, on page 56](#).

- The minimum vertical rack space requirement per chassis is:
 - For a one RU (rack unit) switch, 1.75 inches (4.4 cm)
 - For a one and a half RU (rack unit) switch, 2.63 (6.68 cm)
 - For a two RU (rack unit) switch, 3.5 inches (8.8 cm)
 - For a three RU (rack unit) switch, 5.25 inches (13.3 cm)
- The width between the rack-mounting rails must be at least 17.75 inches (45.0 cm) if the rear of the device is not attached to the rack. For four-post EIA racks, this measurement is the distance between the two front rails.

Four-post EIA cabinets (perforated or solid-walled) must meet the following requirements:

- The minimum spacing for the bend radius for fiber-optic cables should have the front-mounting rails of the cabinet offset from the front door by a minimum of 3 inches (7.6 cm).
- The distance between the outside face of the front mounting rail and the outside face of the back mounting rail should be 23.0 to 30.0 inches (58.4 to 76.2 cm) to allow for rear-bracket installation.

Requirements Specific to Standard Open Racks

If you are mounting the chassis in an open rack (no side panels or doors), ensure that the rack meets the following requirements:

- The minimum vertical rack space per chassis must be equal to the rack unit (RU) of the chassis. One rack unit is equal to 1.75 inches (4.4 cm).
- The distance between the chassis air vents and any walls should be 2.5 inches (6.4 cm).

Requirements Specific to Perforated Cabinets

A perforated cabinet has perforations in its front and rear doors and side walls. Perforated cabinets must meet the following requirements:

- The front and rear doors must have at least a 60 percent open area perforation pattern, with at least 15 square inches (96.8 square cm) of open area per rack unit of door height.
- The roof should be perforated with at least a 20 percent open area.
- The cabinet floor should be open or perforated to enhance cooling.

The Cisco R Series rack conforms to these requirements.

Cable Management Guidelines

To help with cable management, you might want to allow additional space in the rack above and below the chassis to make it easier to route all of the fiber optic or copper cables through the rack.



APPENDIX **B**

System Specifications

- [Environmental Specifications, on page 57](#)
- [Switch Dimensions, on page 57](#)
- [Switch and Module Weights and Quantities, on page 58](#)
- [Transceiver and Cable Specifications, on page 58](#)
- [Switch Power Input Requirements, on page 58](#)
- [Power Specifications, on page 59](#)
- [Power Cable Specifications, on page 61](#)
- [Regulatory Standards Compliance Specifications, on page 63](#)

Environmental Specifications

Environment		Specification
Temperature	Ambient operating temperature	32 to 104°F (0 to 40°C)
	Ambient nonoperating	−40 to 158°F (−40 to 70°C)
Relative humidity	Nonoperating	5 to 85%
Altitude	Operating	0 to 13,123 feet (0 to 4,000 meters)

Switch Dimensions

Switch	Width	Depth	Height
Cisco Nexus 93216TC-FX2	17.4 inches (44.2 cm)	23.6 inches (59.9 cm)	3.38 inches (8.59 cm) (2 RU)

Switch and Module Weights and Quantities

Component	Weight per Unit	Quantity
Cisco Nexus 93216TC-FX2 Chassis (N9K-C93216TC-FX2)	27.4 lb (12.4 kg)	1
Fan Module	—	2
– Port-side exhaust (blue) (NXA-FAN-160CFM-PE)	1.3 lb (0.59 kg)	
– Port-side intake (burgundy) (NXA-FAN-160CFM-PI)	1.3 lb (0.59 kg)	
Power Supply module	—	2 (1 for operations and 1 for redundancy)
– 1200-W AC port-side exhaust (blue) (NXA-PAC-1200W-PE)	2.64 lb (1.2 kg)	
– 1200-W AC port-side intake (burgundy) (NXA-PAC-1200W-PI)		
– 1200-W HVAC/HVDC dual-direction (white) (N9K-PUV-1200W)		
– 930-W DC port-side exhaust (blue) (NXA-PDC-930W-PE)		
– 930-W DC port-side intake (burgundy) (NXA-PDC-930W-PI)		

Transceiver and Cable Specifications

To determine which transceivers, adapters, and cables are supported by this switch, see <https://www.cisco.com/c/en/us/support/interfaces-modules/transceiver-modules/products-device-support-tables-list.html>.

To see the transceiver specifications and installation information, see <https://www.cisco.com/c/en/us/support/interfaces-modules/transceiver-modules/products-device-support-tables-list.html>.

Switch Power Input Requirements

The following table lists the typical amount of power that the switch consumes. It also lists the maximum amount of power that you must provision for the switch and power supply for peak conditions.



Note

Some power supplies have capabilities that are greater than the maximum power requirements for a switch. To determine the power consumption characteristics for the switch, use the typical and maximum requirements that are listed in the following table.

Switch	Typical Power Consumption (AC or DC)	Maximum Power Consumption (AC or DC)	Heat Dissipation Requirement
Cisco Nexus 93216TC-FX2	580 W	965 W	3292.717 BTUs per hour

Power Specifications

Power specifications include the specifications for each type of power supply module.

1200-W AC Power Supply Specifications

These specifications apply to the following 1200-W AC power supplies:

Characteristic	Specification
AC input voltage	Nominal range: 100-120 VAC, 200-240 VAC
AC input frequency	Nominal range: 50 to 60 Hz (Range: 47-63 Hz)
Maximum AC input current	10 A at 100-120 VAC 8 A at 200-240 VAC
Maximum output power per power supply	800 W at 100-120 VAC 1200 W at 200-240 VAC
Maximum hold-up time	12 ms at 650 W
Power supply output voltage	12 VDC
Power supply standby voltage	12 VDC
Efficiency rating	Climate Savers Platinum Efficiency (80Plus Platinum certified)
Form factor	RSP1

1200-W HVAC/HVDC Power Supply Specifications

These specifications apply to the 1200-W HVAC/HVDC (N9K-PUV-1200W) power supplies.

Characteristic	Specification
Input voltage <ul style="list-style-type: none"> • AC (for 1230 W output) • DC (for 1230 W output) 	Nominal (Range) <ul style="list-style-type: none"> • 200 to 277 VAC
AC input frequency	Nominal: 50 to 60 Hz (Range: 47-63 Hz)

Characteristic	Specification
Maximum AC input current	100 VAC, 10A
Maximum inrush current	35 A (cold turn on); 70 A (hot turn on)
Maximum output Watts <ul style="list-style-type: none"> • For 200 to 277 VAC • For 192 to 400 VDC 	Per power supply <ul style="list-style-type: none"> • 1230 W • 1230 W
Power supply output voltage <ul style="list-style-type: none"> • For 200 to 277 VAC • For 192 to 400 VDC 	Per power supply <ul style="list-style-type: none"> • 12 VDC at 100 A • 12 VDC at 100 A
Power supply standby voltage	12 V at 2.5 A
Efficiency rating	Climate Savers Platinum Efficiency (80Plus Platinum certified)
Form factor	RSP1

930-W DC Power Supply Specifications

These specifications apply to the following power supplies:

- NXA-PDC-930W-PE
- NXA-PDC-930W-PI

Characteristic	Specification
DC input voltage range	Nominal range: -48 to -60 VDC nominal (Range: -40 to -60 VDC)
Maximum DC input current	23 A at -48 VDC
Maximum output power per power supply	930 W
Maximum inrush current	35 A (sub-cycle duration)
Maximum hold-up time	8 ms at 930 W
Power supply output voltage	12 VDC
Power supply standby voltage	12 VDC
Efficiency rating	Greater than 92% at 50% load
Form factor	RSP1

Power Cable Specifications

The following sections specify the power cables that you can order and use with this switch.

Power Cable Specifications for AC Power Supplies

Locale	Power Cord Part Number	Cord Set Description
	CAB-C13-C14-2M	Power Cord Jumper, C13-C14 Connectors, 6.6 feet (2.0 m)
	CAB-C13-CBN	Cabinet jumper power cord, 250 VAC, 10 A, C14-C13 connectors, 2.3 feet (0.7 m)
Argentina	CAB-250V-10A-AR	250 V, 10 A, 8.2 feet (2.5 m)
Australia	CAB-9K10A-AU	250 VAC, 10 A, 3112 plug, 8.2 feet (2.5 m)
Brazil	CAB-250V-10A-BR	250 V, 10 A, 6.9 feet (2.1 m)
European Union	CAB-9K10A-EU	250 VAC, 10 A, CEE 7/7 plug, 8.2 feet (2.5 m)
India	CAB-IND-10A	10 A, 8.2 feet (2.5 m)
India	CAB-C13-C14-2M-IN	Power Cord Jumper, C13-C14 Connectors, 6.6 feet (2.0 m)
Israel	CAB-250V-10A-IS	250 V, 10 A, 8.2 feet (2.5 m)
Italy	CAB-9K10A-IT	250 VAC, 10 A, CEI 23-16/VII plug, 8.2 feet (2.5 m)
Japan	CAB-C13-C14-2M-JP	Power Cord Jumper, C13-C14 Connectors, 6.6 feet (2.0 m)
North America	CAB-9K12A-NA	125 VAC, 13 A, NEMA 5-15 plug, 8.2 feet (2.5 m)
North America	CAB-AC-L620-C13	NEMA L6-20-C13, 6.6 feet (2.0 m)
North America	CAB-N5K6A-NA	200/240V, 6A, 8.2 feet (2.5 m)
Peoples Republic of China	CAB-250V-10A-CN	250 V, 10 A, 8.2 feet (2.5 m)
South Africa	CAB-250V-10A-ID	250 V, 10 A, 8.2 feet (2.5 m)
Switzerland	CAB-9K10A-SW	250 VAC, 10 A, MP232 plug, 8.2 feet (2.5 m)

Locale	Power Cord Part Number	Cord Set Description
United Kingdom	CAB-9K10A-UK	250 VAC, 10 A, BS1363 plug (13 A fuse), 8.2 (2.5 m)
All except Argentina, Brazil, and Japan	NO-POWER-CORD	No power cord included with switch

HVAC/HVDC Power Cables Supported by ACI-Mode and NX-OS Mode Switches

Part Number	Cord Set Description	Photo
CAB-HVAC-SD-0.6M	HVAC 2-foot (0.6 m) cable with Saf-D-Grid and SD connectors 277V AC	
CAB-HVAC-C14-2M	HVAC 6.6-foot (2.0 m) cable with Saf-D-Grid and C14 (use for up to 240 V) connector 250V AC	
CAB-HVAC-RT-0.6M	HVAC 2-foot (0.6 m) cable with Saf-D-Grid and RT connector 277V AC	
CAB-HVDC-3T-2M	HVDC 6.6-foot (2.0 m) cable with Saf-D-Grid and three terminal connectors 300V AC / 400V DC (+200/-200 V DC)	
NO-POWER-CORD	All except Argentina, Brazil, and Japan No power cord included with switch	Not applicable

Table 2: HVAC/HVDC Power Cables Callout Table

1	Connect this end to the power supply unit.
---	--

DC Power Cable Specifications

Part Number	Description	Photo
NXA-PDC-930W-PE/PI	The 930W DC power supply (NXA-PDC-930W-PE/PI) is shipped with cable CAB-48DC-40A-8AWG.	

Regulatory Standards Compliance Specifications

The following table lists the regulatory standards compliance for the switch.

Table 3: Regulatory Standards Compliance: Safety and EMC

Specification	Description
Regulatory compliance	Products should comply with CE Markings according to directives 2004/108/EC and 2006/95/EC.
Safety	<ul style="list-style-type: none"> • CAN/CSA-C22.2 No. 60950-1 Second Edition • EN 60950-1 Second Edition • IEC 60950-1 Second Edition • AS/NZS 60950-1 • GB4943

Specification	Description
EMC: Emissions	<ul style="list-style-type: none">• 47CFR Part 15 (CFR 47) Class A• AS/NZS CISPR22 Class A• CISPR22 Class A• EN55022 Class A• ICES003 Class A• VCCI Class A• EN61000-3-2• EN61000-3-3• KN22 Class A• CNS13438 Class A
EMC: Immunity	<ul style="list-style-type: none">• EN55024• CISPR24• EN300386• KN 61000-4 series
RoHS	The product is RoH-6 compliant with exceptions for leaded-ball grid-array (BGA) balls and lead press-fit connectors.



APPENDIX C

LEDs

- [Switch Chassis LEDs, on page 65](#)
- [Fan Module LEDs, on page 66](#)
- [Power Supply LEDs, on page 66](#)

Switch Chassis LEDs

The BCN, STS, and ENV, LEDs are located on the left side of the front of the switch. The port LEDs appear as triangles pointing up or down to the nearest port.

LED	Color	Status
BCN	Flashing blue	The operator has activated this LED to identify this switch in the chassis.
	Off	This switch is not being identified.
STS	Green	The switch is operational.
	Flashing amber	The switch is booting up.
	Amber	Temperature exceeds the minor alarm threshold.
	Red	Temperature exceeds the major alarm threshold.
	Off	The switch is not receiving power.
ENV	Green	Fans and power supply modules are operational.
	Amber	At least one fan or power supply module is not operating.

LED	Color	Status
(port)	Green	Port admin state is 'Enabled', SFP is present and the interface is connected (that is, cabled, and the link is up).
	Amber	Port admin state is 'Disabled', or the SFP is absent, or both.
	Off	Port admin state is 'Enabled' and SFP is present, but interface is not connected.

Fan Module LEDs

The fan module LED is located below the air holes on the front of the module.

LED	Color	Status
STS	Green	The fan module is operational.
	Red	The fan module is not operational (fan is probably not functional).
	Off	Fan module is not receiving power.

Power Supply LEDs

The power supply LEDs are located on the left front portion of the power supply. Combinations of states indicated by the Okay (🟢) and Fault (⚠️) LEDs indicate the status for the module as shown in the following table.

🟢 LED	⚠️ LED	Status
Green	Off	Power supply is on and outputting power to the switch.
Flashing green	Off	Power supply is connected to a power source but not outputting power to the switch—power supply might not be installed in the chassis.
Off	Off	Power supply is not receiving power.
Green	Flashing amber	Power supply warning—possibly one of the following conditions: <ul style="list-style-type: none"> • High voltage • High power • Low voltage • Slow power supply fan



APPENDIX **D**

Additional Kits

- [Rack Mount Kit NXK-ACC-RMK-2RU](#), on page 67
- [Rack Mount Kit N9K-C9300-RMK](#), on page 68
- [Vent Bracket](#), on page 68

Rack Mount Kit NXK-ACC-RMK-2RU

The following table lists and illustrates the contents for the 2-RU rack-mount kit (NXK-ACC-RMK-2RU).

Illustration	Description	Quantity
	Mount kit • Rack-mount brackets (2) • Rack-mount retainer brackets • Rack-mount slider rails (2) • Rack-mount retainer clips (2) • Phillips countersink screws (8) • Flat head screws (4)	1
Not applicable	EAC Compliance document	1
Not applicable	Hazardous substances list for customers in China	1

The following table lists and illustrates the console cable (CAB-CONSOLE-RJ45) that can be ordered.

Illustration	Description	Quantity
	Console cable with DB-9F and RJ-45F connectors	1

Rack Mount Kit N9K-C9300-RMK

The following table lists and illustrates the contents for the 2-RU rack-mount kit (N9K-C9300-RMK).

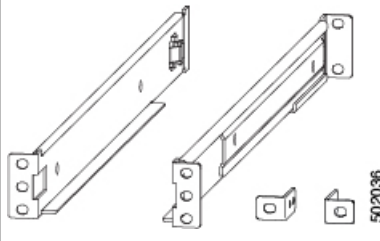
Illustration	Description	Quantity
	Rack-mount kit <ul style="list-style-type: none"> • Bottom support rails (2) • Front-mount brackets (2) 	1

Vent Bracket

The following table lists and illustrates the vent bracket (NXA-ACC-BAV3).

Note

You require the vent bracket (NXA-ACC-BAV3) for NEBS (Network Equipment-Building System) compliance only.

Illustration	Description	Quantity
	Vent bracket	1