

ARISTA

Quick Start Guide

7000 Series 1 RU – Gen 3 Data Center Switches (Tool-less)

DCS-7050QX-32S	DCS-7050TX-72
DCS-7050SX-64	DCS-7050TX-96
DCS-7050SX-72	DCS-7280SE-64
DCS-7050SX-96	DCS-7280SE-68
DCS-7050TX-48	DCS-7280SE-72
DCS-7050TX-64	

Arista Networks

www.arista.com

PDOC-00041-07

Headquarters	Support	Sales
5453 Great America Parkway Santa Clara, CA 95054 USA		
408 547-5500	408 547-5502 866 476-0000	408 547-5501 866 497-0000
www.arista.com	support@arista.com	sales@arista.com

© Copyright 2015 Arista Networks, Inc. The information contained herein is subject to change without notice. Arista Networks and the Arista logo are trademarks of Arista Networks, Inc in the United States and other countries. Other product or service names may be trademarks or service marks of others.

Chapter 1 Overview

1.1 Scope

This guide is intended for properly trained service personnel and technicians who need to install the following Arista Networks Data Center Switches:

- DCS-7050QX-32S
- DCS-7050SX-64
- DCS-7050SX-72
- DCS-7050SX-96
- DCS-7050TX-48
- DCS-7050TX-64
- DCS-7050TX-72
- DCS-7050TX-96
- DCS-7280SE-64
- DCS-7280SE-68
- DCS-7280SE-72

Important! Only qualified personnel should install, service, or replace this equipment.

1.2 Receiving and Inspecting the Equipment

Upon receiving the switch, inspect the shipping boxes and record any external damage. Retain packing materials if you suspect that part of the shipment is damaged; the carrier may need to inspect them.

If the boxes were not damaged in transit, unpack them carefully. Ensure that you do not discard any accessories that may be packaged in the same box as the main unit.

Inspect the packing list and confirm that you received all listed items. Compare the packing list with your purchase order. [Appendix B](#) provides a list of components included with the switch.

1.3 Installation Process

The following tasks are required to install and use the switch:

- Step 1** Select and prepare the installation site ([Section 2.1](#)).
- Step 2** Assemble the installation tools listed in [Section 2.2](#).
- Step 3** Attach the mounting brackets and install the switch in an equipment rack ([Chapter 3](#)).
- Step 4** Connect the switch to the power source and network devices ([Chapter 4](#)).
- Step 5** Configure the switch ([Chapter 5](#)).

Important! Class 1 Laser Product: This product has provisions to install Class 1 laser transceivers which provide optical coupling to the communication network. Once a Class 1 laser product is installed, the equipment is a Class 1 Laser Product (Appareil à Laser de Classe 1). The customer is responsible for selecting and installing the Class 1 laser transceiver and for insuring that the Class 1 AEL (Allowable Emission Limit) per EN/IEC 6-825, CSA E60825-1, and Code of Federal Regulations 21 CFR 1040 is not exceeded after the laser transceiver have been installed. Do not install laser products whose class rating is greater than 1. Refer to all safety instructions that accompanied the transceiver prior to installation. Only Class 1 laser devices, certified for use in the country of installation by the cognizant agency are to be utilized in this product.

Important! Ultimate disposal of this product should be in accordance with all applicable laws and regulations.

1.4 Safety Information

Refer to the Arista Networks document Safety Information and Translated Safety Warnings available at:

<http://www.arista.com/en/support/docs/eos>

1.5 Obtaining Technical Assistance

Any customer, partner, reseller or distributor holding a valid Arista Service Contract can obtain technical support in any of the following ways:

- **Email:** support@arista.com. This is the easiest way to create a new service request.
Include a detailed description of the problem and the output of “show tech-support”.

- **Web:** www.arista.com/en/support.

A support case may be created through the support portal on our website. You may also download the most current software and documentation, as well as view FAQs, Knowledge Base articles, Security Advisories, and Field Notices.

- **Phone:** 866-476-0000 or 408-547-5502.

Important! No user serviceable parts inside. Refer all servicing to qualified service personnel.

1.6 Specifications

Table 1 lists the specifications of Arista Data Center switches covered by this guide.

Table 1: Switch Specifications

Size (W x H x D)	DCS-7050QX-32S DCS-7050SX-64, -72, -96 DCS-7050TX-48, -64 DCS-7050TX -72, -96 DCS-7280SE-64, -68, -72	44.5 x 4.4 x 40.6 cm (19 x 1.75 x 16 inches) 44.5 x 4.4 x 40.6 cm (19 x 1.75 x 16 inches) 44.5 x 4.4 x 40.6 cm (19 x 1.75 x 16 inches) 44.5 x 4.4 x 52.3 cm (19 x 1.75 x 20.6 inches) 44.5 x 4.4 x 52.3 cm (19 x 1.75 x 20.6 inches)
Weight	DCS-7050QX-32S DCS-7050SX-64 DCS-7050SX-72 DCS-7050SX-96 DCS-7050TX-48 DCS-7050TX-64 DCS-7050TX-72 DCS-7050TX-96 DCS-7280SE-64 DCS-7280SE-68 DCS-7280SE-72	9.1 kg (20 pounds) 8.6 kg (19 pounds) 8.6 kg (19 pounds) 9.1 kg (20 pounds) 7.7 kg (17 pounds) 8.6 kg (19 pounds) 10.0 kg (22 pounds) 10.5 kg (22 pounds) 10.0 kg (22 pounds) 10.1 kg (22 pounds) 10.2 kg (22 pounds)
Operating Temperature	all switches	0° to 40° C (32° to 104° F)
Storage Temperature	all switches	-25° to 70° C (-13° to 158° F)
Operating Altitude	all switches	0 to 3,000 meters (0 to 10,000 feet)
Relative Humidity	all switches	5 to 90%
Power Input (AC Power)	all switches	100 - 240 VAC, 6.5 - 3.0 A, 50/60 Hz
Power Draw (Typical / Maximum)	DCS-7050QX-32S DCS-7050SX-64 DCS-7050SX-72 DCS-7050SX-96 DCS-7050TX-48 DCS-7050TX-64 DCS-7050TX-72 DCS-7050TX-96 DCS-7280SE-64 DCS-7280SE-68 DCS-7280SE-72	150 W / 300 W 140 W / 220 W 144 W / 276 W 159 W / 290 W 305 W / 367 W 315 W / 387 W 349 W / 440 W 355 W / 455 W 263 W / 381 W 313 W / 405 W 262 W / 399 W

Chapter 2 Preparation

2.1 Site Selection

The following criteria should be considered when selecting a site to install the switch:

- **Temperature and Ventilation:** For proper ventilation, install the switch where there is ample airflow to the front and back of the switch. The ambient temperature should not go below 0° or exceed 40° C.

Important! To prevent the switch from overheating, do not operate it in an area where the ambient temperature exceeds 40°C (104°F).

- **Airflow Orientation:** Determine airflow direction of the four fan modules and two power supply modules on the rear panel. Fan and power supply module handles indicate airflow direction:
 - **Blue Handle:** Air Inlet module.
 - **Red Handle:** Air Exit module.

Figure 1 displays fan and power supply module locations on the rear panel. Their red handles indicate that they are air exit modules. Verify that each module has the same airflow direction. Base the switch orientation on the airflow direction of the modules to assure the air inlet is always oriented toward the cool aisle:

- **Air Exit modules:** orient the rear panel toward the hot aisle.
- **Air Inlet modules:** orient the rear panel toward the cool aisle.

If the airflow direction is not compatible with the installation site, contact your sales representative to obtain modules that circulate air in the opposite direction.

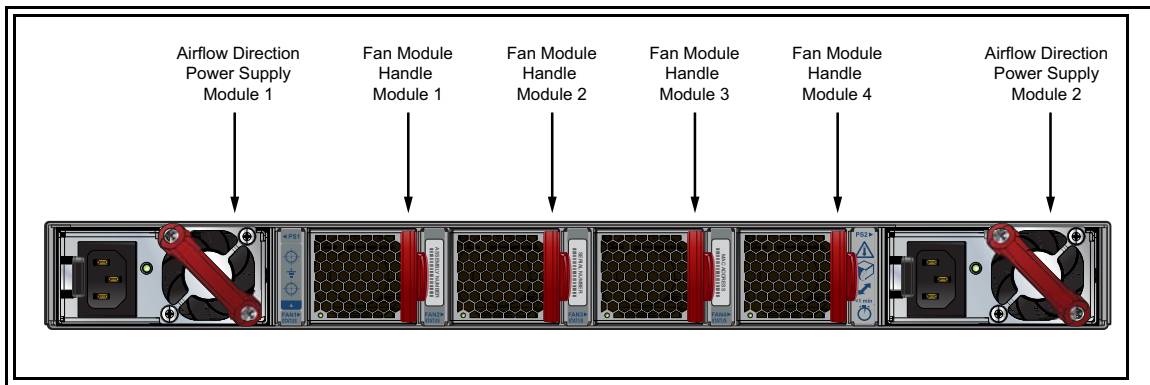

Figure 1: Airflow Direction Labels

- **Rack Space:** Install the switch in a 19" rack or cabinet. The switch height is 1 RU. The accessory kit provides mounting brackets for two-post and four-post racks.

When mounting the switch in a partially filled rack, load the rack from bottom to top, with the heaviest equipment at the bottom. Load the switch at the bottom if it is the only item in the rack.

- **Power Requirements:** Power requirements vary by switch and power supply model. Refer to [Table 1](#) for information regarding your specific system.

Two circuits provide redundancy protection. [Section 4.2](#) describes power cable requirements.

Important! The power input plug-socket combination must be accessible at all times; it provides the primary method of disconnecting power from the system.

- **Other Requirements:** Select a site where liquids or objects cannot fall onto the equipment and foreign objects are not drawn into the ventilation holes. Verify these guidelines are met:
 - Clearance areas to the front and rear panels allow for unrestricted cabling.
 - All front and rear panel indicators can be easily read.
 - Power cords can reach from the power outlet to the connector on the rear panel.

Important! All power connections must be removed to de-energize the unit.

2.2 Tools Required for Installation

Each switch provides an accessory kit that contains parts that are required to install the switch. In addition to the accessory kit, the following tools and equipment are required to install the switch:

Two-Post Rack

- Screws or rack mounting nuts and bolts.
- Screwdriver

Four-Post Rack (Toolless)

No additional equipment required.

Four-Post Rack (Conventional)

- Screws or rack mounting nuts and bolts.
- Screwdriver

Accessory kit does not include screws for attaching the switch to the equipment rack. When installing the switch into an equipment rack with unthreaded post holes, nuts are also required to secure the switch to the rack posts.

2.3 Electrostatic Discharge (ESD) Precautions

Observe these guidelines to avoid ESD damage when installing or servicing the switch.

- Assemble or disassemble equipment only in a static-free work area.
- Use a conductive work surface (such as an antistatic mat) to dissipate static charge.
- Wear a conductive wrist strap to dissipate static charge accumulation.
- Minimize handling of assemblies and components.
- Keep replacement parts in their original static-free packaging.
- Remove all plastic, foam, vinyl, paper, and other static-generating materials from the work area.
- Use tools that do not create ESD.

Chapter 3 Rack Mounting the Switch

Important! The rack mounting procedure is identical for all switches covered by this guide. Illustrations in this chapter depict the mounting of a DCS-7050QX-32S switch.

- [Section 3.1](#) provides instructions for mounting the switch in a two-post rack.
- [Section 3.2](#) provides instructions for mounting the switch in a four-post rack.

After completing the instructions for your rack type, proceed to [Chapter 4: Cabling the Switch](#).

3.1 Two-Post Rack Mount

To mount the switch onto a two-post rack, assemble the mounting brackets to the chassis, then attach the brackets to the rack posts. Two-post accessory kits include the following two-post mounting parts:

- 2 three-hole mounting brackets

Each chassis side has attachment pins that align with bracket holes. Pin orientation is symmetric and equidistant, supporting bracket placements where the flange is flush the front switch panel, flush with the rear panel, or not flush with either panel. Each bracket hole includes a key-opening for placing the bracket flush with the chassis and then locking it into place.

Important! Attachment pins must be lock all three upper bracket holes.

[Figure 2](#) displays proper bracket mount configuration examples.

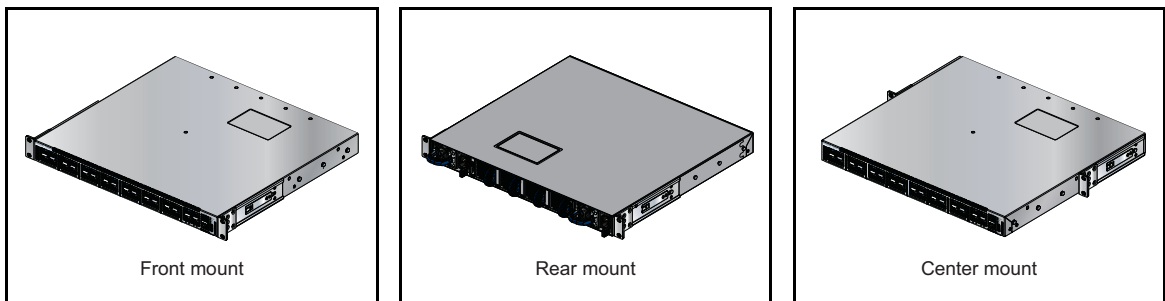

Figure 2: Bracket Mount Examples for Two-Post Rack Mount

[Figure 3](#) displays improper bracket mount configuration examples.

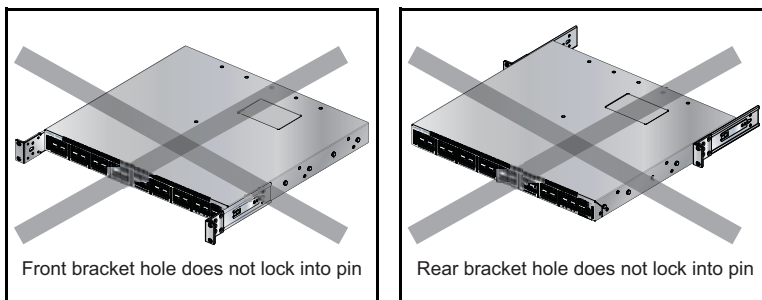

Figure 3: Improper Bracket Mount Examples for Two-Post Rack Mount

3.1.1 Attaching Mounting Brackets to the Chassis

This procedure attaches mounting brackets to the switch chassis ([Figure 4](#)).

- Step 1** Align the mounting brackets with the attachment pins to obtain the desired mounting position.
- Step 2** Place the bracket flush on the chassis with attachment pins protruding through key-openings.
- Step 3** Slide the bracket toward the front flange until the bracket clip locks with an audible click.

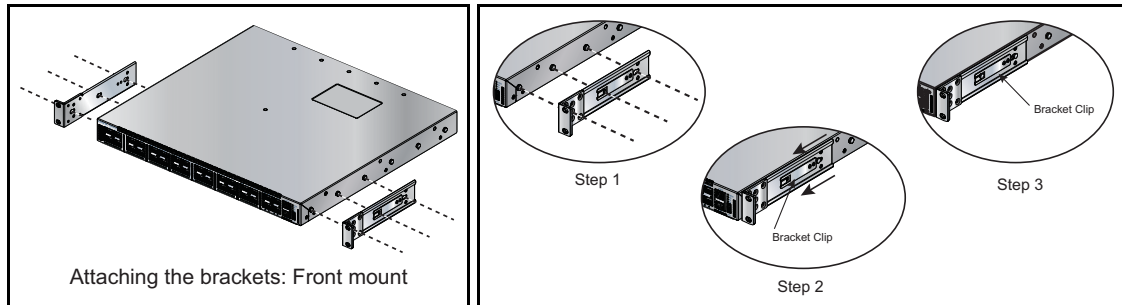

Figure 4: Attaching the Mounting Brackets to the Switch Chassis

To remove the mounting bracket from the chassis, lift the front edge of the mounting bracket clip with a flathead screwdriver and slide the bracket away from the front flange (opposite from the installation direction).

3.1.2 Inserting the Switch into the Rack

This procedure attaches the switch to the rack ([Figure 5](#)).

- Step 1** Lift the chassis into the rack. Position the flanges against the rack posts.

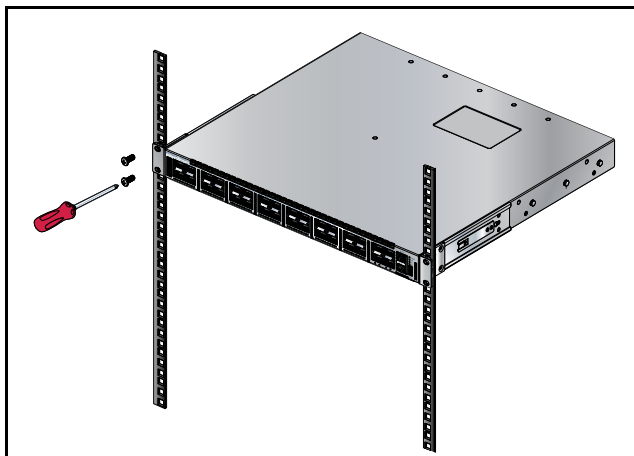

Figure 5: Inserting the Switch into the Rack

- Step 2** Select mounting screws that fit your equipment rack.
- Step 3** Attach the bracket flanges to the rack posts.

After completing the two-post rack mount, proceed to [Chapter 4: Cabling the Switch](#).

3.2 Four-Post Rack Mount

The switch is mounted onto a four-post rack by assembling two rails onto the rear posts, sliding the switch onto the rails, then securing the switch to the front posts.

The installation kit provides the following four-post mounting parts:

- 2 six-hole mounting brackets
- 2 rail-rods
- 2 rail-slides

The rail-rods and rail-slides assemble into two identical slide-rails.

Each chassis side has attachment pins that align with bracket holes. Pin orientation is symmetric and equidistant, supporting bracket placements where the flange is flush the front switch panel, flush with the rear panel, or not flush with either panel. Each bracket hole includes a key-opening for placing the bracket flush with the chassis and then locking it into place.

Important! Attachment pins must lock at least five of the six bracket holes.

Figure 6 displays proper bracket mount configuration examples.

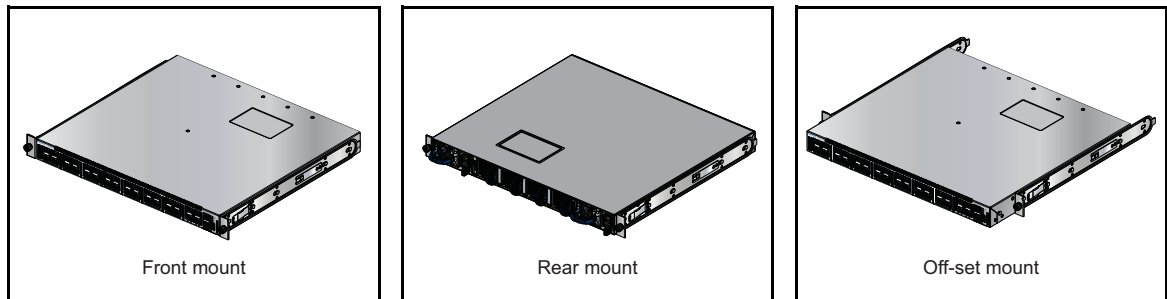

Figure 6: Bracket Mount Examples for Four-Post Rack Mount

Figure 7 displays an improper bracket mount configuration example.

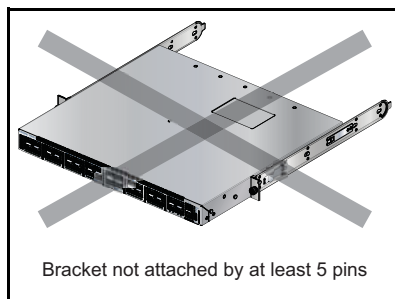

Figure 7: Improper Bracket Mount Example for Four-Post Rack Mount

3.2.1 Attaching Mounting Brackets to the Chassis

Figure 8 displays the front bracket alignment for mounting the switch into a four-post rack.

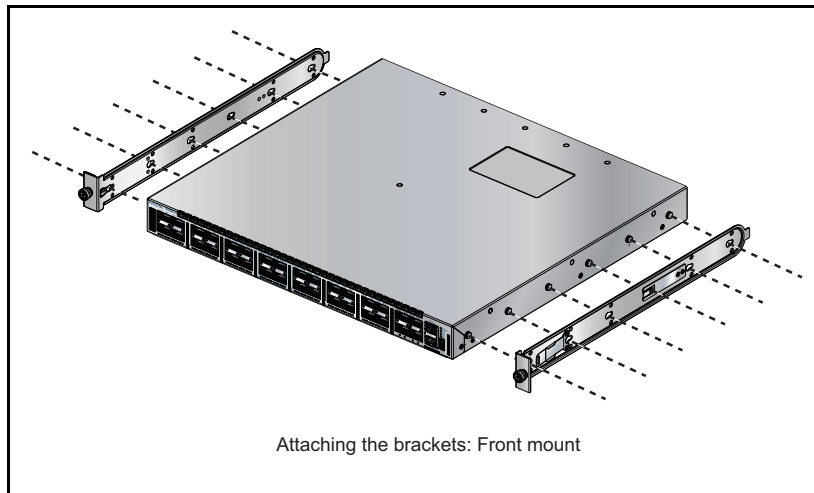

Figure 8: Attaching the Mounting Brackets to the Switch Chassis

This procedure attaches mounting brackets to the switch chassis as depicted by Figure 9.

- Step 1** Align the mounting brackets with the attachment pins to obtain the desired mounting position.
- Step 2** Place the bracket flush on the chassis with attachment pins protruding through key-openings.
- Step 3** Slide the bracket toward the front flange until the bracket clip locks with an audible click.

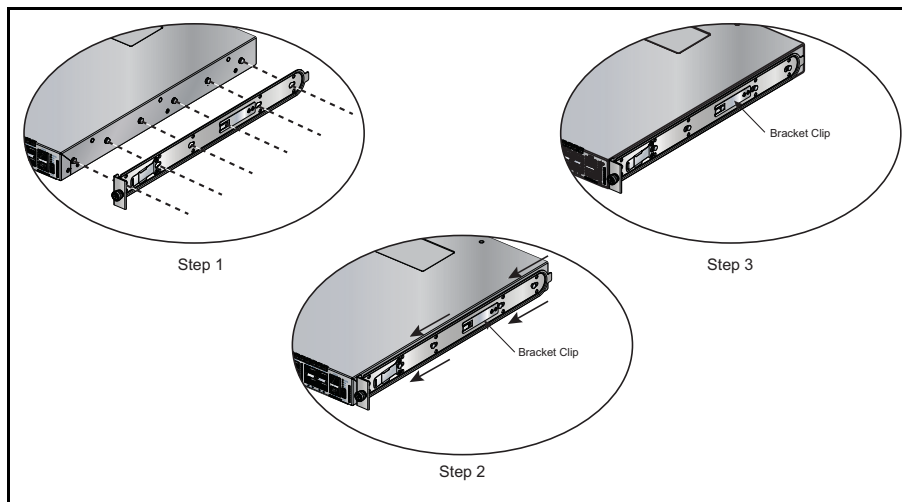

Figure 9: Attaching the Mounting Brackets to the Switch Chassis

To remove the mounting bracket from the chassis, lift the front edge of the mounting bracket clip with a flathead screwdriver and slide the bracket away from the front flange (opposite from the installation direction).

3.2.2 Assembling the Rails onto the Equipment Rack

Rail-rods and rail-slides assemble into two identical rails. Each rail connects a front post to a rear post. When the rails are installed, the switch slides on the rails into the rack. Each bracket includes a screw that attaches the switch to the rail.

Each end of an assembled rail contains two rack plugs (Figure 10, inset A). The rails are installed into a rack by inserting the plugs into rack slots. When installing rails into posts with threaded or rounded holes, remove all plugs located on both sides of the assembled rails, then install the rails with bolts that fit the rack.

This procedure attaches the rails to a four post rack:

Step 1 Slide a rail-rod into a rail-slide (Figure 10) until the rail clip makes an audible click.

The rail clip prevents the extension of the rail beyond the maximum supported distance between the front and rear rack posts.

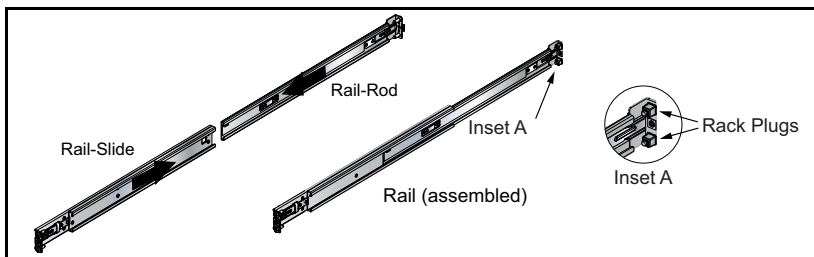

Figure 10: Assembling the Rails

Step 2 Attach rail to the right rear rack post by inserting rod-end rack plugs into post slots (Figure 11, inset A). The slide assembly must be inside the right posts, relative to the left rack posts.

If the rack plugs were previously removed, use bolts to attach the rail to the rack.

Step 3 Attach the slide end of the rail to the front post by extending the rail end past the post, then contracting the rail while guiding the rack plugs into the post (Figure 11, inset B).

Step 4 Repeat step 1 through step 3 for the left posts. Ensure the rails are on the same horizontal level.

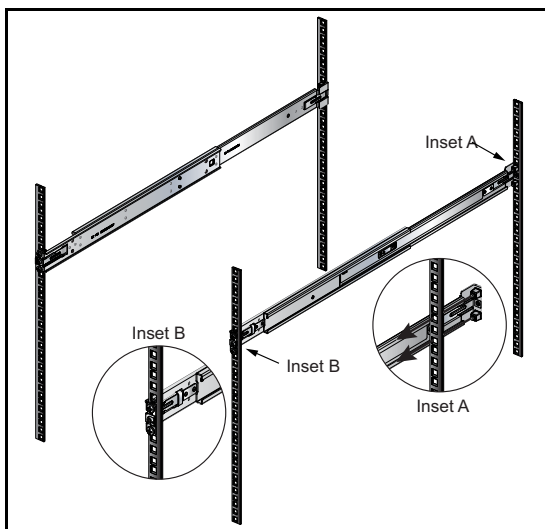

Figure 11: Attaching the Rails

3.2.3 Attaching the Switch to the Rack

After the rails are installed, the switch slides on the rails into the rack. Each bracket includes a thumb screw that attaches the switch to the rail.

Step 1 Lift the switch into the rack and insert the mounting brackets into the slide rails.

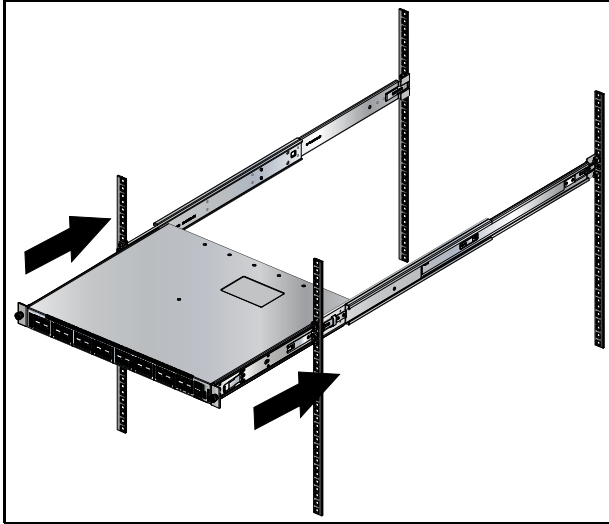

Figure 12: Inserting the Switch onto the Rails

Step 2 Slide the switch on the rails, toward the rear posts, until the mounting bracket flanges are flush with the rail flanges attached to the rack posts.

Step 3 Attach the bracket flanges to the rack post using the quick-release thumb screws supplied with the brackets.

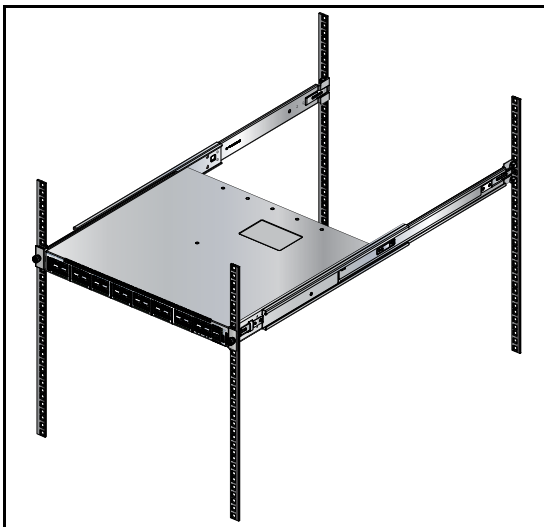

Figure 13: Attaching the Switch to the Rack Posts

After completing the four-post rack mount, proceed to [Chapter 4: Cabling the Switch](#).

Chapter 4 Cabling the Switch

4.1 Grounding the Switch

After mounting the switch into the rack, connect the switch to the data center ground. [Figure 14](#) displays the location of the grounding pads located on the bottom corners of the front panel.

Important! Grounding wires and grounding lugs (M4 x 0.7) are not supplied. Wire size should meet local and national installation requirements. Commercially available 6 AWG wire is recommended for installations in the U.S.

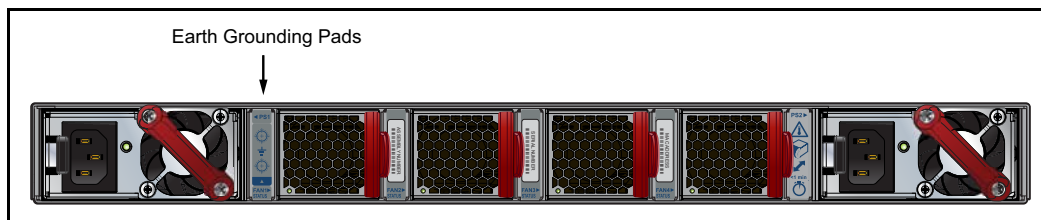

Figure 14: Earth Grounding Pad Sockets

4.2 Connecting Power Cables

Important! Installation of this equipment must comply with local and national electrical codes. If necessary, consult with the appropriate regulatory agencies and inspection authorities to ensure compliance.

The switch operates with two installed power supplies. At least one power supply must connect to a power source. Two circuits provide redundancy protection. [Appendix D](#) displays the location of the power supplies on the rear panel of the switch.

Important! Read all installation instructions before connecting the system to the power source.

- **Non-Redundant Configuration:** Connect power to either of the two power supplies.
- **Redundant Power Supply Configuration:** Connect power to both power supplies.
- **Power down the Switch:** Remove all power cords and wires from the power supplies.

Important! This equipment must be grounded. Never defeat the ground conductor.

Important! This unit requires overcurrent protection.

[Figure 15](#) displays an AC power supply, including the power socket on the left side of the module. The AC power supply connects to a circuit that provides the required power, as specified by [Table 1](#).

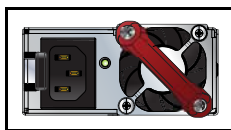

Figure 15: AC Power Supply

The power supplies require power cables that comply with IEC-320 and have a C13 plug. The accessory kit provides two IEC-320 C13 to C14 power cables.

4.3 Connecting Serial and Management Cables

The accessory kit includes the following cables:

- RJ-45 to DB-9 serial adapter cable.
- RJ-45 Ethernet cable.

Table 2 lists the pin connections of the RJ-45 to DB-9 adapter cable.

Table 2: RJ-45 to DB-9 Connections

RJ-45		DB-9		RJ-45		DB-9	
RTS	1	8	CTS	GND	5	5	GND
DTR	2	6	DSR	RXD	6	3	TXD
TXD	3	2	RXD	DSR	7	4	DTR
GND	4	5	GND	CTS	8	7	RTS

The front panel contains the console, management, and USB ports. Figure 16 displays the ports on the DCS-7050QX-32S switch. Appendix C displays the front panel of all switches covered by this guide.

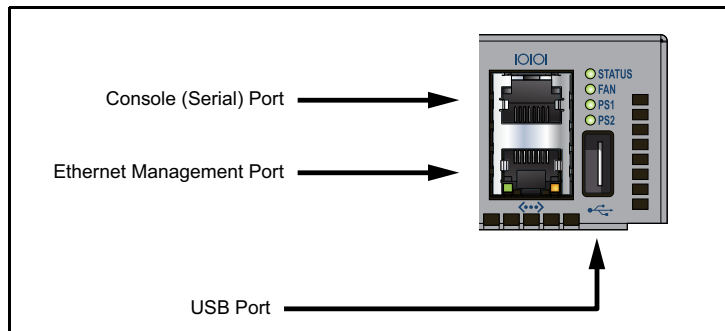

Figure 16: Front Panel Ports

Connect the front panel ports as follows:

- **Console (Serial) Port:** Connect to a PC with the RJ-45 to DB-9 serial adapter cable. The switch uses the following default settings:
 - 9600 baud
 - No flow control
 - 1 stop bit
 - No parity bits
 - 8 data bits
- **Ethernet Management Port:** Connect to 10/100/1000 management network with RJ-45 Ethernet cable.
- **USB Port:** The USB port may be used for software or configuration updates.

Caution Excessive bending can damage interface cables, especially optical cables.

Chapter 5 Configuring the Switch

Arista switches ship from the factory in Zero Touch Provisioning (ZTP) mode. ZTP configures the switch without user intervention by downloading a startup configuration file or a boot script from a location specified by a DHCP server. To manually configure a switch, ZTP is bypassed. The initial configuration provides one username (*admin*) accessible only through the console port because it has no password.

When bypassing ZTP, initial switch access requires logging in as *admin*, with no password, through the console port. Then you can configure an *admin* password and other password protected usernames.

This manual configuration procedure cancels ZTP mode, logs into the switch, assigns a password to *admin*, assigns an IP address to the management port, and defines a default route to a network gateway.

Step 1 Provide power to the switch (Section 4.2).

Step 2 Connect the console port to a PC (Section 4.3).

As the switch boots without a *startup-config* file, it displays the following through the console:

```
The device is in Zero Touch Provisioning mode and is attempting to
download the startup-config from a remote system. The device will not
be fully functional until either a valid startup-config is downloaded
from a remote system or Zero Touch Provisioning is cancelled. To cancel
Zero Touch Provisioning, login as admin and type 'zerotouch cancel'
at the CLI.
```

```
localhost login:
```

Step 3 Log into the switch by typing **admin** at the login prompt.

```
localhost login:admin
```

Step 4 Cancel ZTP mode by typing **zerotouch cancel**. *IMPORTANT: This step initiates a switch reboot.*

```
localhost>zerotouch cancel
```

Step 5 After the switch boots, log into the switch again by typing **admin** at the login prompt.

```
Arista EOS
localhost login:admin
Last login: Fri Mar 15 13:17:13 on console
```

Step 6 Enter global configuration mode.

```
localhost>enable
localhost#config
```

Step 7 Assign a password to the *admin* username with the **username secret** command.

```
localhost(config)#username admin secret pxq123
```

Step 8 Configure a default route to the network gateway.

```
localhost(config)#ip route 0.0.0.0/0 192.0.2.1
```

Step 9 Assign an IP address (*192.0.2.8/24* in this example) to an Ethernet management port.

```
localhost(config)#interface management 1
localhost(config-if-Ma1/1)#ip address 192.0.2.8/24
```

Step 10 Save the configuration by typing **write memory** or **copy running-config startup-config**.

```
localhost#copy running-config startup-config
```

When the management port IP address is configured, use this command to access the switch from a host, using the address configured in step 9:

```
ssh admin@192.0.2.8
```

Refer to the **Arista Networks User Manual** for complete switch configuration information.

Appendix A Status Indicators

A.1 Front Indicators

A.1.1 Switch Indicators

Front panel LEDs are located on the right side of the chassis and display system, fan, and power supply status. [Appendix C](#) displays the front panels of all switches covered by this guide.

[Figure 17](#) displays the DCS-7050QX-32S front panel LEDs.

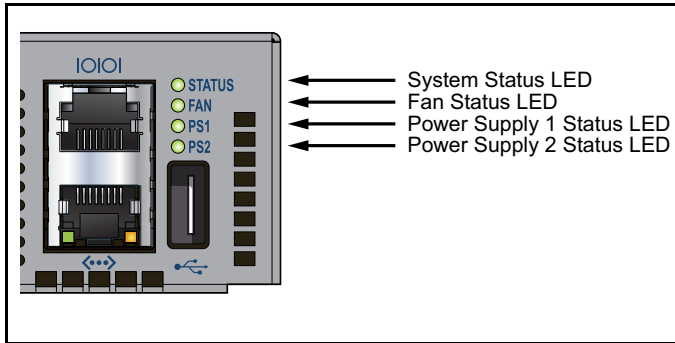

Figure 17: System Status Indicators

Table 3: Switch Indicators LED States

LED Name	LED State	Device Status
System Status	Blinking Green	System powering up.
	Green	All power supplies and fans are operating normally.
	Blue	The locator function is active.
	Red	A power supply or fan is missing or in a failed state.
Fan Status	Green	All fans are operating normally.
	Red	One or more fans are not inserted or have failed.
PSU [1:2]	Green	PSU functioning and fully operational. AC present, Aux output ON, and Main output ON.
	Blinking Green	Standby mode - Main is turned off, and Aux is on. AC present, Aux output ON, and Main output turned off.
	Blinking Amber	Fault of any kind - Electrical, thermal, or fan. This fault can be due to (high/low) voltage, current, temperature, stuck rotor, faulty cables, or internal damage. Power supply has AC power but is not plugged in to the chassis.
	Off	PSU not powered. Power supply plugged in to a live chassis, with no AC cord.

Important! For the LED Name "PSU [1:2]" the LED State "Blinking Amber" applies to all "Device Status" states as described. In order to narrow down the specific condition, you must login to the switch to view the specific device state. Refer to the **Arista User Manual's** *Switch Environment Control* chapter, under the topic *Viewing Environment Status*, for further information on the `show environment` commands.

A.1.2 Port Indicators

Port LEDs, located in the vicinity of their corresponding ports, provide link and operational status. [Figure 18](#) displays the Port LED location on the DCS-7050QX-32S switch. [Appendix C](#) displays the port LED locations of all switches covered by this guide.

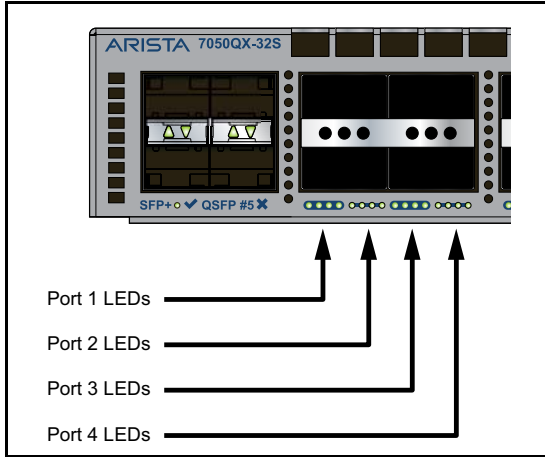

Figure 18: Port LEDs

[Table 4](#) provides status conditions that correspond to port LED states. Port LED behavior for QSFP+ and SFP+ ports is consistent.

Table 4: Port LED States

LED State	Status
Off	Port link is down.
Green	Port link is up.
Yellow	Port is software disabled.
Flashing Yellow	Port failed diagnostics.

A.2 Rear Status Indicators

Fan and power supply modules are accessed from the rear panel. Each fan and power supply module contains an LED that reports the module status. [Appendix D](#) displays the rear panel of all switches covered by this guide.

Fan Status LEDs are on the fan modules, as displayed in [Figure 19](#).

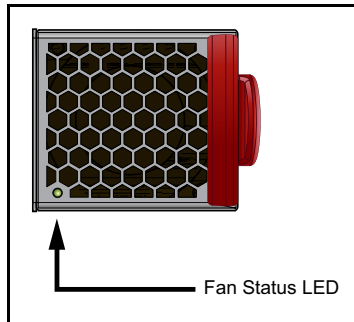

Figure 19: Fan Status LED

[Table 5](#) provides status conditions that correspond to fan status LED states.

Table 5: Fan Status LED States

LED State	Status
Off	The fan module is inserted but not receiving power – it may not be properly seated.
Green	The fan is operating normally.
Red	The fan has failed or a power supply module was removed from the switch.

The Power Supply Status LEDs are on the power supply modules, as displayed in [Figure 20](#).

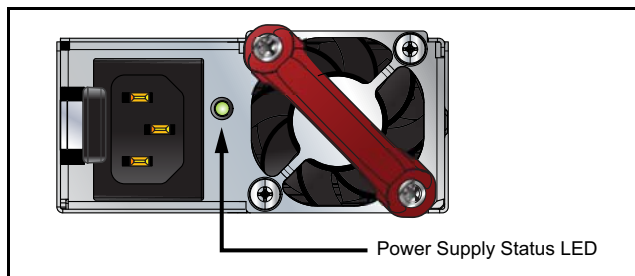

Figure 20: Power Supply Status LED

[Table 6](#) provides status conditions that correspond to power supply status LED states.

Table 6: Power Supply Status LED States

LED State	Status
Off	Power supply not connected to AC power or not inserted fully.
Green	Power supply operating normally.
Amber	Power supply has overheated or failed.

Appendix B Parts List

Each switch provides an accessory kit that contains parts that are required to install the switch. This appendix lists the installation parts contained in the switch accessory kit.

B.1 Rack Mount Parts

B.1.1 Four-Post Rack Mount Parts



Figure 21: Four-Post Rack Mount Parts

B.1.2 Two-Post Rack Mount Parts

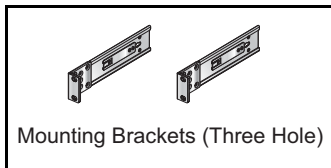

Figure 22: Two-Post Rack Mount Parts

B.2 Cables

Table 7: Switch Cables

Quantity	Description
2	Power cables: IEC-320/C13-C14, 13 A, 250 V
1	RJ-45 Patch Panel Cable
1	RJ-45 to DB9 Adapter Cable

Warning! All provided power cables are for use only with Arista products.

警告

すべての電源コードは提供する製品で使用するためだけを目的としている。

電源コードの他の製品での使用の禁止

Arista が提供するすべての電源コードは、Arista の製品でのみ使用してください。

Appendix C Front Panel

This appendix displays the front panel of all switches covered by this guide.

DCS-7050QX-32S

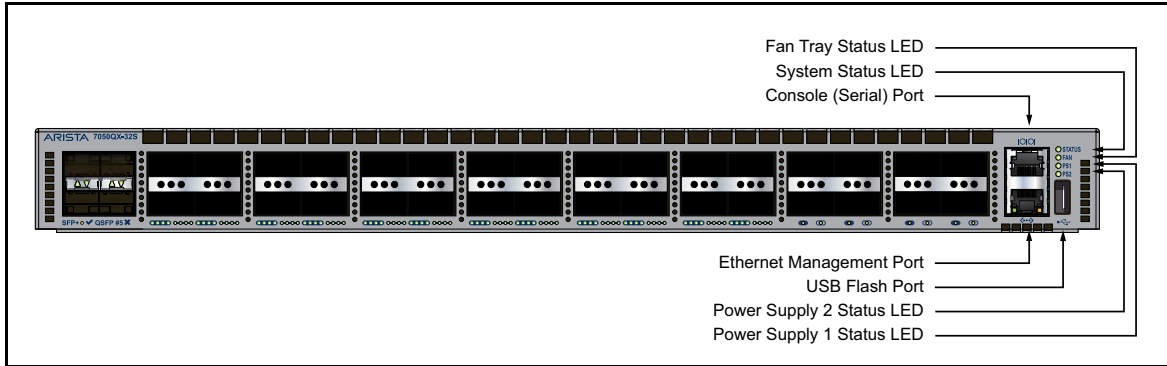

Figure 23: DCS-7050QX-32S Front Panel

DCS-7050SX-64

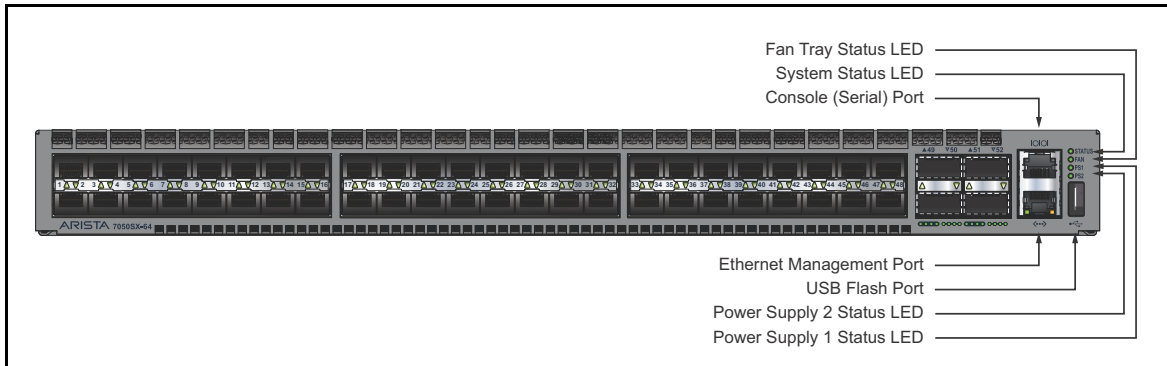

Figure 24: DCS-7050SX-64 Front Panel

DCS-7050SX-72

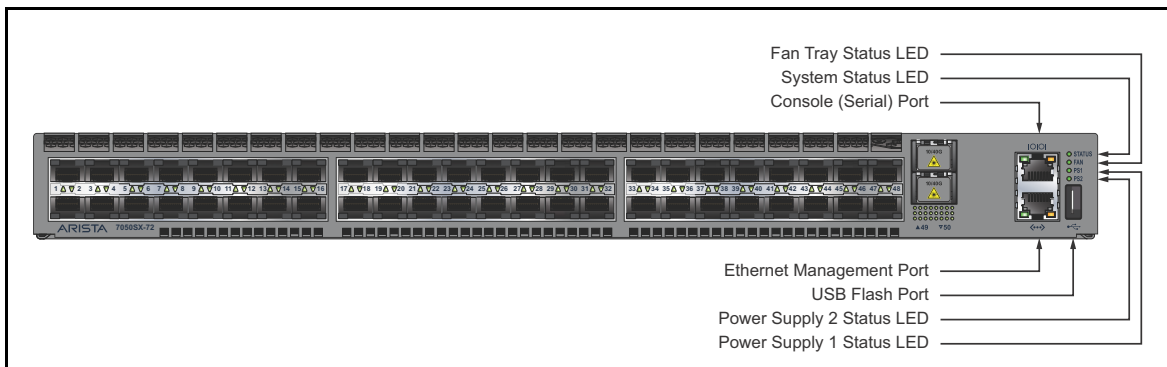

Figure 25: DCS-7050SX-72 Front Panel

DCS-7050SX-96

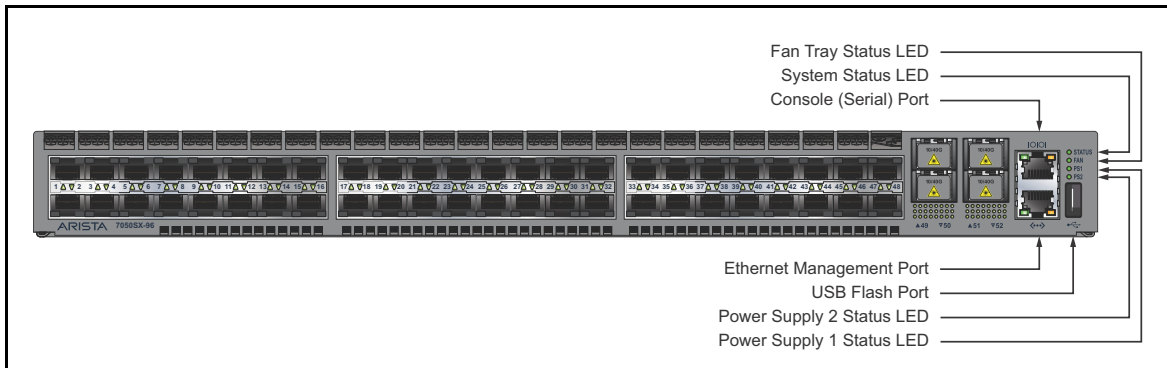

Figure 26: DCS-7050SX-96 Front Panel

DCS-7050TX-48

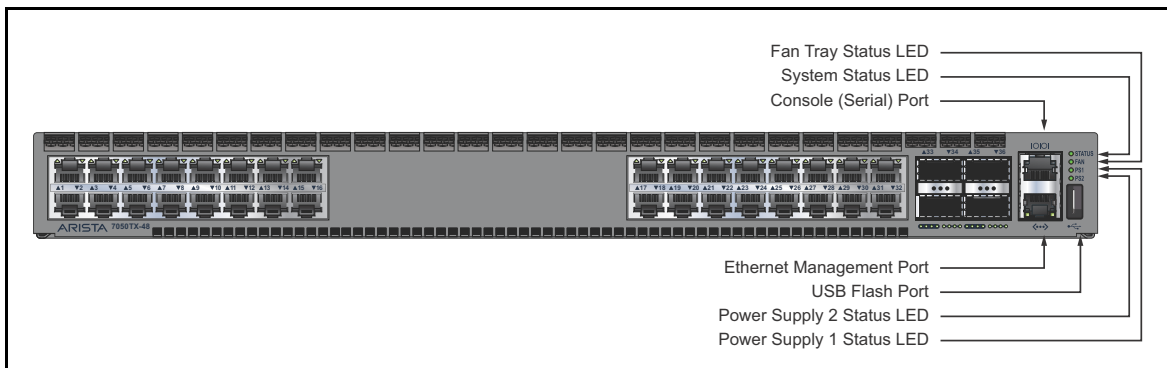

Figure 27: DCS-7050TX-48 Front Panel

DCS-7050TX-64

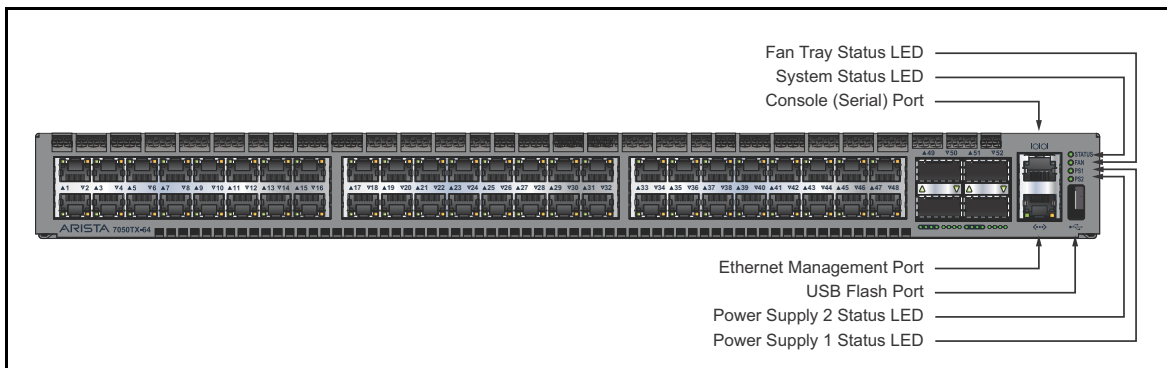

Figure 28: DCS-7050TX-64 Front Panel

DCS-7050TX-72

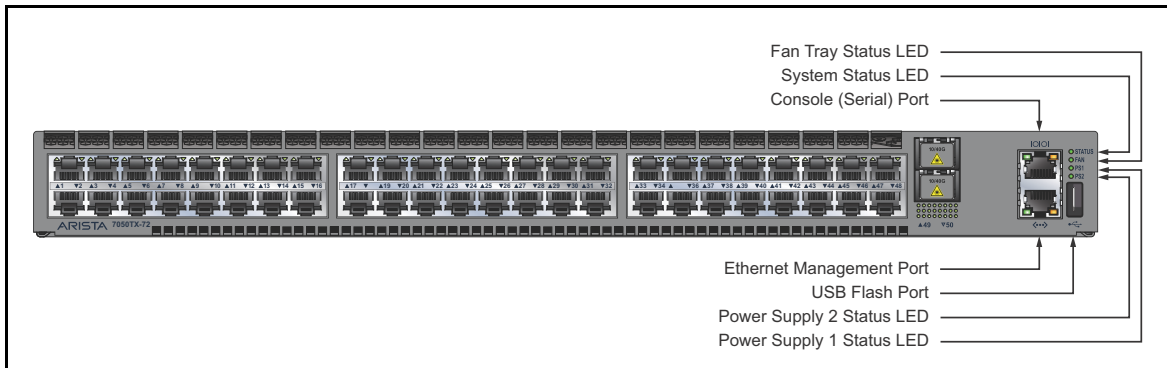

Figure 29: DCS-7050TX-72 Front Panel

DCS-7050TX-96

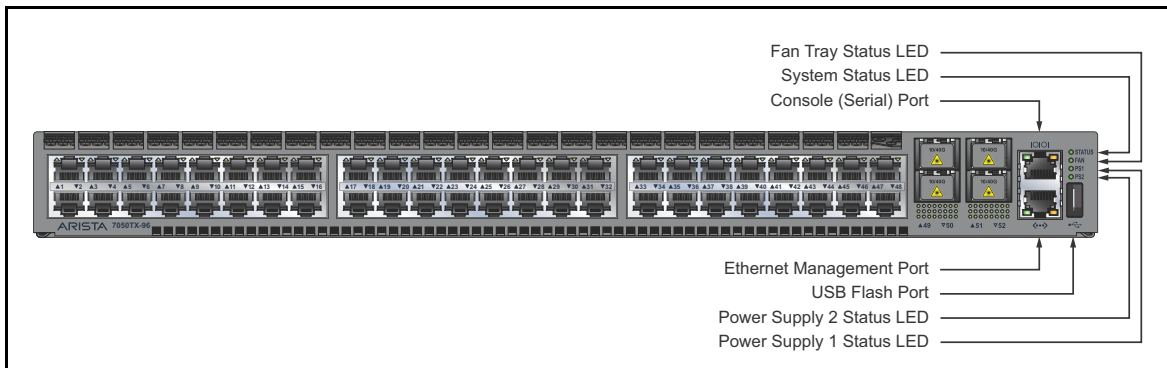

Figure 30: DCS-7050TX-96 Front Panel

DCS-7280SE-64

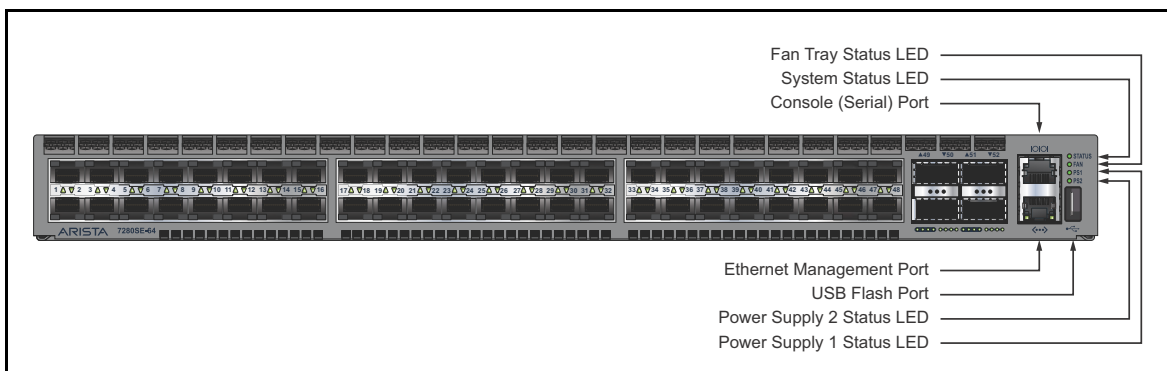

Figure 31: DCS-7280SE-64 Front Panel

DCS-7280SE-68

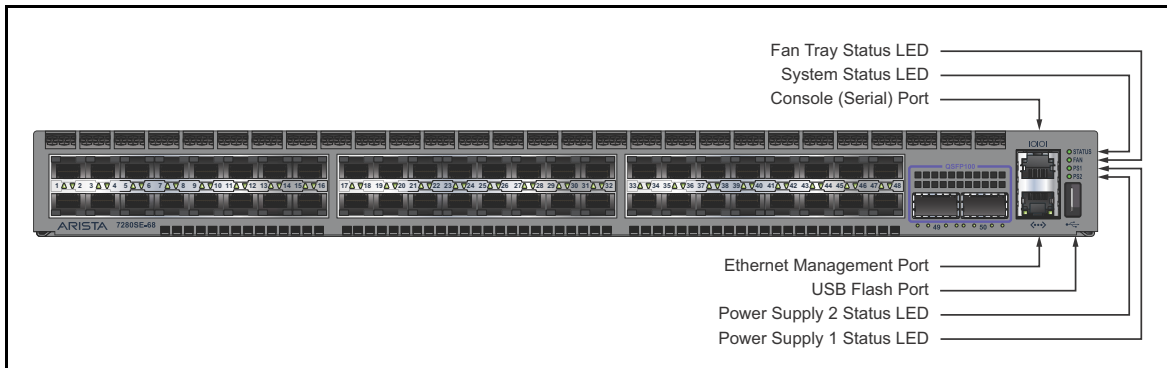

Figure 32: DCS-7280SE-68 Front Panel

DCS-7280SE-72

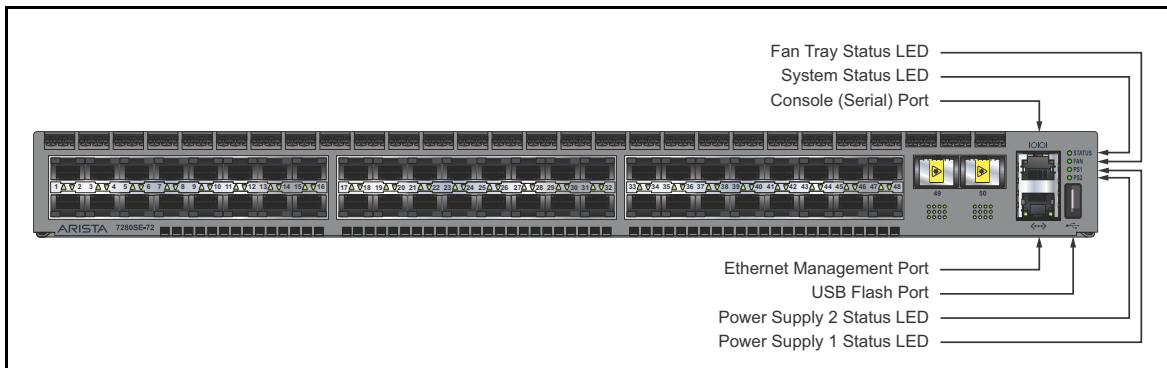

Figure 33: DCS-7280SE-72 Front Panel

Appendix D Rear Panel

This appendix displays the rear panel of all switches covered by this guide.

All Models

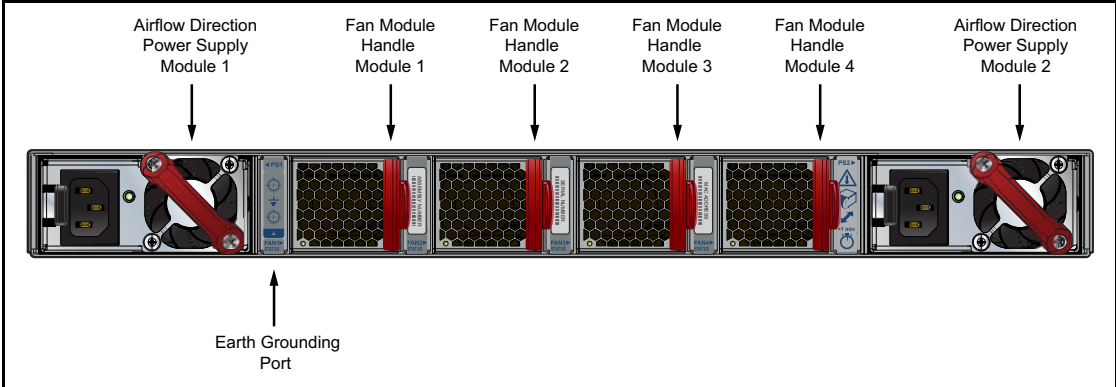

Figure 34: Rear Panel