



## OWNER'S MANUAL

**FOR TECHNICAL ASSISTANCE:**

**CONTACT YOUR LOCAL DISTRIBUTOR**

For a list of distributors, visit the Merit Industries, Inc. website

[www.meritind.com](http://www.meritind.com)



merit industries, inc.

PM0235-02



## Table of Contents

---

**Quick Setup ..... p. 1**

**Site Preparation ..... p. 2**

**Game Description ..... p. 2**

CPU Section ..... p. 2

Coin Drawer Section ..... p. 2

**Sidecar Installation ..... p. 2**

Removing an Endcap ..... p. 2

Attaching a Sidecar ..... p. 2

Replacing an Endcap ..... p. 2-3

**General Care  
and Maintenance ..... p. 3**

Screen Calibration ..... p. 3

General Circuit Board  
Handling Information ..... p. 3

Cleaning the Cabinet ..... p. 3

Cleaning the Touchscreen  
Monitor ..... p. 3

Cleaning the Fans and  
Vents ..... p. 3

**Megatouch™ EZ MAXX Software**

**Options Settings ..... p. 4**

**Game Name and Score Needed  
for Initial Replay ..... p. 5**

**Megatouch™ EZ MAXX Game Operation**

Game Setup ..... p. 6

System Settings ..... p. 6-7

Game Menu ..... p. 7

Coin-In Menu ..... p. 8

Books Screen ..... p. 9

**Megatouch™ EZ MAXX Video Billboard**

Video Billboard  
Icon Functions ..... p. 10-11

Video Billboard Font  
Controls Screen ..... p. 11

Video Billboard Clip Art  
Controls Screen ..... p. 11

**Megatouch™ EZ MAXX Hardware**

**Troubleshooting ..... p. 12-13**

**Parts List and Illustrations**

Game Illustrations ..... p. 14-15

Replacement Parts List ..... p. 16

## MEGATOUCH™ EZ MAXX QUICK SETUP

### UNPACKING & SETTING UP YOUR MEGATOUCH™ EZ MAXX VIDEO GAME

1. Upon opening the carton and removing the packing materials, lift the game out of the box and remove it from the plastic bag. Place the game on a sturdy, level surface.
2. Locate and remove the vinyl pouch containing the manual, warranty card and keys (located on top of, or on the back of, the cabinet). Put the manual, warranty card and keys aside for future use. Clean any adhesive residue that may be left on the cabinet after removing the vinyl pouch.
3. Plug the power cord into a grounded AC outlet.

**NOTE:** *INSIDE THE POUCH ARE TWO KEYS: TWO SETS, EACH, UNLOCK THE REAR DOOR AND THE COIN DRAWER.*

4. Locate the power switch on the back of the game and push the rocker switch to the "ON" position.
5. Turn on the game and wait for the game to go through its boot-up sequence. At the completion of the boot-up sequence, the game will display the main menu screen.

### CALIBRATING THE TOUCHSCREEN

1. Press the black calibrate button located on the connector board in the CPU section of the unit (See Figures 11 and 12 on page 15 of the manual).
2. With your index finger, touch the center of the first circle that appears on the screen. **NOTE:** *YOU MUST HOLD*

*YOUR FINGER ON THE CIRCLE FOR APPROXIMATELY 2 SECONDS FOR THE CALIBRATION TO BE RECOGNIZED.* Once touched a second circle will appear on the screen.

3. With your index finger, touch the center of the second circle that appears on the screen.
4. Once the second circle is touched, a crosshair will appear on the screen. To test the calibration of the screen, touch the crosshair with your finger and slowly drag your finger around the screen. The crosshair should follow your movement. Touch the EXIT TEST icon.

### ADJUSTING THE VOLUME AND MONITOR CONTROLS

**NOTE:** *THE VOLUME AND MONITOR CONTROLS ARE PRESET AT THE FACTORY AND, THEREFORE, MAY NOT NEED TO BE ADJUSTED.*

1. The volume control is accessed through the software; to access the volume control, press the SETUP button located on the connector board in the CPU section of the game, then touch the SYSTEM SETTINGS icon at the Setup Screen, then touch the VOLUME CONTROL icon.
2. Adjust the Monitor Controls, mounted to the back of the LCD screen in the CPU section of the game, as necessary to achieve the desired picture.

### Site Preparation

- Plug the game into a grounded electrical outlet.
- Plug the game into a separate circuit, if at all possible. If a separate circuit is not available, care should be taken to provide a clean and constant voltage.
- Place the game on a flat, level and stable surface.
- Place the game in a location that does not interfere with its proper ventilation.
- Make sure that all fans are operating correctly and that airflow is unobstructed. If any fans are not operating, it is important that they be replaced.
- Make sure nothing is placed on top of the cabinet or next to the fan vents that would inhibit the flow of air.

### Game Description

The base countertop model has 2 key-locked compartments: the rear door section and the coin drawer section. Each individual sidecar has its own key-locked compartment.

### CPU Section

The CPU section is accessible from the rear of the unit in the countertop. The CPU section houses the CRT, the monitor controls, the CPU and I/O boards, the power supply, the main harness, coin meter and the connector board. The Dallas key is located on the I/O board in the countertop model.

### Coin Drawer Section

The coindrawer section is accessible from the rear of the unit. This section is key-locked for security purposes. A sturdy metal box located within this section holds all coins deposited into the machine.

### Sidecar Installation

You can install a number of sidecar options onto your EZ MAXX video game. To install a sidecar, you will need to remove an endcap, attach the desired sidecar and then re-attach the endcap.

### Removing an Endcap

To remove an endcap from the game:

1. Unlock and open the rear door of the game (or the rear door of sidecar, if already attached) to gain access to the endcap latches.
2. Press firmly against the endcap, pull the bottom endcap latch out of its notch and push upward into the upper notch to unlock (See Figure 10 on page 14).
3. Repeat the above procedure for the top latch of the endcap (See Figure 10 on page 14).
4. Remove the endcap from the game.

### Attaching a Sidecar

After you have removed the endcap, you can now attach a sidecar.

To attach a sidecar:

1. Attach the sidecar spacer to the side of the game by lining up the holes on the spacer with the studs on the game chassis (See Figure 9 on page 14).
2. Next, attach the sidecar to the side of the game by lining up the holes on the sidecar with the studs on the game chassis (See Figure 9 on page 14).

**NOTE: BOTH THE SIDECAR SPACER AND THE SIDECAR ITSELF SHOULD BE FLUSH AGAINST THE FRONT OF THE GAME.**

3. Using Figure 11 as a reference, connect the sidecar connector harness to the connector board in the CPU section of the game.

### Replacing an Endcap

Once you have installed the sidecar, you will need to re-attach the endcap to the game.

To replace the endcap:

1. unlock and open the rear door of game (or the rear door of sidecar, if already attached).
2. Line up the studs on the endcap with

the holes on the sidecar (See Figure 9 on page 14). **NOTE: MAKE SURE THAT THE ENDCAP IS FLUSH AGAINST THE FRONT OF THE GAME BEFORE LOCKING INTO PLACE.**

2. Press firmly against the endcap, pull the bottom endcap latch out of the top notch and push downward into the lower notch to lock the sidecar into place (See Figure 10 on page 14).
3. Repeat the above procedure for the top latch of the endcap.
4. Close and lock the rear door of the game or sidecar.

### General Care and Maintenance

**NOTE: THIS GAME SHOULD ONLY BE SERVICED BY QUALIFIED SERVICE PERSONNEL.**

**CAUTION: THERE ARE HIGH VOLTAGE PARTS IN THIS GAME. BE CAREFUL WHEN SERVICING THE INSIDE OF THE GAME. GAME SHOULD ALWAYS BE UNPLUGGED BEFORE SERVICING.**

### Screen Calibration

The machine must be in the idle mode or game select mode to calibrate the touchscreen.

- Locate the black calibrate button on the connector board and press it to enter the screen calibration mode.
- Touch the center of the first circle that appears on the screen. Once you release your finger, a second circle will appear on the screen.

**NOTE: YOU MUST HOLD YOUR FINGER ON THE CIRCLE FOR APPROXIMATELY 2 SECONDS FOR THE CALIBRATION TO BE RECOGNIZED.**

- Touch the center of the second circle that appears on the screen.
- Once the second circle is touched, a crosshair will appear on the screen. To test the calibration of the screen, touch the crosshair with your finger and slowly drag your finger around the screen. The crosshair should follow your movement.
- Touch the "EXIT TEST" icon.

### General Circuit Board Handling Information

Before handling any boards, observe the following procedures:

- Prevent Electro-Static Discharge by:
  1. Storing the boards in the anti-static bags in which they are shipped.
  2. Removing any static charge from your body before handling the boards.
  3. Using a ground strap when handling the boards.
- When plugging in connectors to the board, make sure the connector is inserted straight onto the header and that the connector covers all header pins.
- Do not connect any peripheral device to the board, if the power is still connected to the peripheral or if power is already applied to the board.

### Cleaning the Cabinet

- The cabinet should be cleaned with a damp cloth and mild detergent.

### Cleaning the Touchscreen Monitor

- The touchscreen glass should be cleaned with a damp cloth and isopropyl alcohol or a non-ammonia cleanser. **NOTE: DO NOT USE ANY ABRASIVE OR VINEGAR-BASED CLEANSERS, AS THEY WILL DAMAGE THE TOUCHSCREEN.**

### Cleaning the Fans and Vents

- The fans and vents should be cleaned of any dust and grime on a regular basis to ensure proper ventilation of the game.

**NOTE: DO NOT USE ANY ABRASIVE SOLVENTS, ACID OR VINEGAR-BASED CLEANSERS WHEN CLEANING YOUR GAME. OVER TIME, SUCH CLEANSERS COULD HARM THE TOUCHSCREEN AND ERASE THE DECALS. BE CAREFUL NOT TO USE COMMERCIAL CLEANERS CONTAINING ANY OF THESE SUBSTANCES.**

**Megatouch™ EZ MAXX  
Software Instructions**

**Options Settings**

All current operator-adjustable functions are controlled by accessing the "OPTIONS" icon on the Megatouch™ EZ MAXX Setup screen (See Figure 1 on page 6).

TIMER <sup>1</sup>	YES	NO	ALLOW SEX?
	YES	NO	ALLOW NUDITY? <sup>2</sup>
	YES	NO	ALLOW SEX DURING ATTRACT
	YES	NO	MYSTERY PHRASE SEX CATERGORY? <sup>3</sup>
	YES	NO	MATCHEM UP BABES AND HUNKS? <sup>3</sup>
	YES	NO	MEMOREE BABES AND HUNKS? <sup>3</sup>
	YES	NO	TRIVIA/POWER QUIZ SEX CATERGORY? <sup>3</sup>
	YES	NO	PIX MIX BABES AND HUNKS? <sup>3</sup>
	YES	NO	PHOTO HUNT EROTIC CATERGORY? <sup>3</sup>
SET <sup>4</sup>	YES	NO	PLAYER SELECTABLE LANGUAGE
	OTHER	ENG	DEFAULT LANGUAGE?
	YES	NO	LANGUAGE BUTTONS HAVE FLAGS
	YES	NO	SOLITAIRE FREE GAME?
	YES	NO	TRIVIA/PIVR QUIZ SHOW CORRECT ANSWER?
4/300K	5/1M		TRIVIA ROUND/BONUS?
	YES	NO	POWER SOLITAIRE SPLIT COLUMN MOVE?
	YES	NO	POWER SOLITAIRE FREE GAME?
\$/¢	CREDS		PRICE DISPLAY?
	YES	NO	STRIP POKER MOAN SOUNDS? <sup>3</sup>
	ENG	GER	CHECKERZ RULES?
	NO	YES	AUTO CLEAR HIGH SCORES <sup>5</sup>
	NO	YES	6 STARS ENABLED?
	YES	NO	HI SCORE ACCESS FROM 6 STARS? <sup>6</sup>
	YES	NO	VBB ACCESS FROM 6 STARS? <sup>6</sup>
	YES	NO	VOLUME CONTROL ACCESS FROM 6 STARS <sup>6</sup>
	YES	NO	CALIBRATION ACCESS FROM 6 STARS <sup>6</sup>
	NO	YES	SHOW DECK CARDS
	SHORT	LONG	FAN TIME? <sup>7</sup>
	YES	NO	ALLOW GAME CONTINUATION?
	YES	NO	ALLOW BONUS REPLAY? <sup>8</sup>
	NO	YES	FREE PLAY ENABLED
	NO	YES	EASY MODE ENABLED <sup>9</sup>
	NO	YES	POWER QUIZ CATERGORY SAME FOR ALL
	YES	NO	POWER QUIZ CONSOLATION QUESTION
	NO	YES	CONTINUOUS BONUS ROUND?
	YES	NO	GOLF HAS WOMEN?
	3/G	5/G	PHOTOHUNT HINTS?
	YES	NO	TRI TOWERS FACE-UP PLAYER SELECTABLE?

**Options Settings Notes**

- 1 Touching "TIMER" for the "ALLOW SEX?" setting allows the operator to set times during which adult-oriented categories and games are available to the players. Using the arrows, set the time at which the adult-oriented games and categories will be turned on and set the time at which they'll be turned off. The time is set using 24 hour, "military" time. The factory default settings are set to turn on at 22:00 (10:00 PM) and to turn off at 6:00 (6:00 AM).
- 2 When "ALLOW NUDITY" is set to "YES," a small box will appear to the right. Select from "R" or "X" rated nudity ("X-rated" = full frontal nudity).
- 3 These settings are only available if "ALLOW SEX?" is set to "TIMER" or "YES."
- 4 "SET" is only shown if "Player Selectable Language" is set to "YES." When enabled, the operator can select which of the available languages will be displayed for the user to select. To enable the languages: at the Language Select screen, touch the desired language on the left, then select an open field on the right.
- 5 When "AUTO CLEAR HIGH SCORES" is set to "YES," a small box will appear to the right. Touching this box allows the time period to be set from 1 to 4 weeks (from the time the player name is entered). The factory default setting is two (2) weeks.
- 6 These settings are only available if "6 STARS ENABLED?" is set to "YES."
- 7 This setting is only available if "SHOW DECK CARDS" is set to "YES."
- 8 Setting this to "YES" enables a bonus replay for all games, except Trivia Whiz, Pile On, Strip Poker, Double Solitaire and Mystery Phrase. The *Game Name and Score Needed for Initial Replay* table on the next page shows the scores needed to achieve a bonus replay (after a replay has been earned, the next player must beat the last replay score to earn another replay).
- 9 Easy Mode reduces the number of points needed to reach the bonus round for Hoop Jones (125/150 points), Eleven-Up (68,000/80,000 points), Tri-Towers (64,000/80,000 points), Royal Flash (180,000/200,000 points) and Quik Match (250,000/280,000 points).

**NOTE: THE OPTIONS SETTINGS DISPLAYED ON YOUR GAME WILL DEPEND ON WHICH GAMES ARE SELECTED AS ACTIVE IN THE GAME MENU SCREEN, AS WELL AS THE PROGRAM VERSION USED IN YOUR GAME. OPTIONS SETTINGS CONTROLS FOR INACTIVE GAMES NOT INCLUDED IN YOUR PROGRAM WILL NOT BE DISPLAYED.**

**Game Name and Score Needed  
for Initial Replay**

Great Solitaire	45,000
Run 21	250,000
Royal Flush	300,000
Match'Em Up	200,000
Memoree	300,000
Tri-Towers	125,000
4-Play	1,500,000
Conquest	30,000
11-Up	125,000
Hoop Jones	125
Zip 21	200,000
Checkerz	28,000
Quik Match	400,000
Power Solitaire	55,000
Pix Mix	350,000
Photo Hunt	400,000
Quikcell	100,000
Tai Play	240,000
Puck Shot	3000
Take 2	110,000
Mystery Phrase	325,000
Power Quiz	NO REPLAY
Pile On	NO REPLAY
Strip Poker	NO REPLAY
Double Solitaire	NO REPLAY
Trivia Whiz	NO REPLAY
MegaLink Trivia	NO REPLAY
Tennis Ace	NO REPLAY
Chug 21	250,000
Symbol Tri-Towers	125,000
Symbol 11-Up	125,000
Symbol Take 2	110,000
Hooter	NO REPLAY
Trip Flip	NO REPLAY
3 Blind Mice	NO REPLAY
Route 66	45,000
Super Route 66	55,000
Fast Lane	100,000
Championship Golf	NO REPLAY
Monster Madness	NO REPLAY
Lookout	400,000
Snapshot	NO REPLAY
Air Shot	
QB Zone	NO REPLAY
Wild 8's	
Pharaoh's 9	
Wild Apes	
GO-O-O-AL	



To Enter This Screen, Touch The “Setup” Button In The Coinbox Section or CPU Section

To Enter This Screen, Touch “System Settings” At The Setup Screen



Figure 1 - Megatouch™ Game Setup Screen

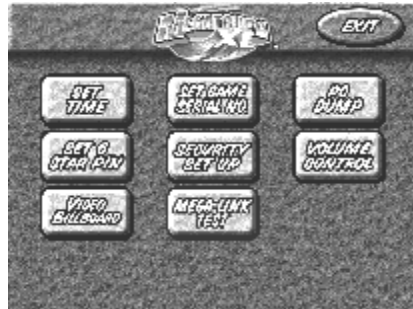

Figure 2 – System Settings Screen

Coin-In Menu	Enters the coin/credit setup screen.
Game Menu	Enters the game menu selection screen.
Display Books	Enters the bookkeeping statistics screen.
Options	Displays the options settings screen. The options settings displayed on this page will vary depending on which games are active (see page 4 for a list of options settings.)
Video Test	Displays video test screens. Touch the screen to cycle through.
Touchscreen Test	Enters the touchscreen test for checking touchscreen calibration.
High-Scores	Enters the clear high scores screen. Touch game to select, touch “CLEAR CURRENT” to clear the high scores for that game. Touch “CLEAR ALL” to clear all high scores.
Clear Credits	Erases all credits on the machine.
Free Credits	Adds credits without using coin switch. Free credits are listed separately in the books screen.
System Settings	Enters the System Settings screen which gives the operator access to the Set Time, Set Game Serial Number, PC Dump, Set 6 Star PIN, Security Setup, Volume Control, Video Billboard and MegaLink Test screens. See the System Settings screen for explanations of each option.
Exit	Returns the game to the attract mode.

### System Settings

The System Settings controls allow the operator to access the Set Time, Set Serial Game Number, PC Dump, Set 6 Star PIN, Security Setup, Volume Control, Video Billboard and Mega-Link Test screens.

Set Time	Brings up the Set System Date and Time screen. Time is shown in 24-hour, “military” time (e.g. 5:00pm = 17:00). Use the up and down arrows to set the time and/or the date.
Set Game Serial Number	Brings up the Set Game Serial Number screen. Enter the game’s serial number using the keypad.
PC Dump	PC Dump allows the books information to be downloaded to a PC. Software for the PC is required for it to operate. Contact Merit Customer Product Support and Services for information.
Set 6 Star PIN*	Brings up the Set 6 Star PIN screen via the info button in the main menu screen. Touch the stars in the programmed order to give access to the Video Billboard, High Scores, Volume Control and Calibration screens (to allow access to any of these screens through 6 Stars, the options settings must be set to “YES” for each screen; see the options settings list on page 4.)

Security Setup	Brings up the Set Security PIN screen. From this screen, the operator can set the PIN number and select which of the features (Coin-In Menu, Game Menu, Display Books, Options, High Scores, Free Credits and Set 6 Star PIN) will be protected by the PIN. To set the PIN, first touch "SET" on the keypad. Then, enter your 4-digit PIN using the keypad and touch "ENTER." The game will prompt you to re-enter your PIN to confirm. After confirming your PIN, touch the icon for each of the features you wish to protect with the PIN.
Volume Control	Brings up the Volume Control screen. Touch the volume control icon to adjust the volume up or down. This screen allows you to sample the sound volume without exiting the screen. The on-screen volume control can also be accessed using "Six Stars."
Video Billboard	See page 10 for Video Billboard operation instructions.
Mega Link Test	Allows the operator to test the connection between linked games.

**\*Six Stars Enabled**

This feature allows access to the Clear High Scores, Volume Control, Video Billboard and Calibration, without having to remove the coin box. If the Six Stars Enabled dip switch is set to "YES," touching the info button in the main menu will cause six numbered stars to appear on the screen. Touching these stars in the programmed order will bring up a screen with icons for the Video Billboard, High Scores and Volume Control screens (provided the appropriate options settings have been set to "YES"). To set the sequence in which the stars must be touched, go to the "System Settings" screen, touch the "Set Six Star PIN" icon and set the sequence.

**To Enter This Screen, Touch "Game Menu" At The Setup Screen**



Figure 3 - Game Menu Screen

The game list and prices are programmed using this screen. The top of the screen shows the various game menu names. The fields below show the game positions available, with the price for each game. The list on the right shows all games available for that category. The lower buttons will clear the selected item from the player's game menu (CLEAR 1), clear all of the games from the player's game menu (CLEAR), reset the selected game menu to the default setting (DEFAULT) and reset all of the game menus to the default settings (DEFAULT ALL).

To program the player's game lists, first select the category in which you want the game to appear, by touching that category's name at the top of the screen. Choose the menu position you want the game to occupy, by touching that position. Then, touch the desired game name, from the game list on the right side of the screen. That game will now appear in the menu (a game cannot appear in a game list more than once). Games currently in the displayed category will appear shaded in the game list on the right. To adjust the price, touch the price in the game menu. Each touch will rotate the price from 25¢ (1CR), to 50¢ (2CR), to 75¢ (3CR), to \$1 (4CR) and back to 25¢ (1CR). Touch "EXIT" when done.

**NOTE: TOP GAMES** ALLOWS THE OPERATOR TO ENTER UP TO 6 GAMES IN THAT CATEGORY. SET THE TOP GAME THRESHOLD TO TELL THE GAME HOW MANY PLAYS QUALIFIES A GAME FOR THE TOP GAMES LIST. ONCE A GAME REACHES THAT NUMBER OF PLAYS, IT WILL AUTOMATICALLY BE ADDED TO THE TOP GAMES CATERGORY. THE DEFAULT THRESHOLD IS "10."

**To Enter The Coin/Credit Setup Screen, Touch “Coin-In Menu” At The Setup Screen**

Game cost can be controlled two ways: by changing the number of credits required to play a game or by changing the cost of a credit. The Coin-In Menu allows you to adjust the cost of a credit, as well as providing a way to give players “bonus” credits for depositing a higher amount of money.

When programming the Coin-In Menu, E1 is set for the lowest value coin, E2 for the next highest value, etc. If all four coin inputs are not used, the unused inputs must be set “N/A.” Adjust the coin/credit/meter pulse settings by touching the “plus” and “minus” signs on the field you want to change.

COIN VALUE	COIN INPUT	COINS	=	CREDITS	&	METER PULSES
10p	1E	3		1		3
20p	2E	3		2		6
50p	3E	1		2	player premium 25p/credit	5
1£	4E	1		5	player premium 20p/credit	10



In the above example (UK currency), each game costs one (1) credit and the cost for a single credit is 30p. This method is preferred if you want game cost to always be reflected as “1 credit.”

COIN VALUE	COIN INPUT	COINS	=	CREDITS	&	METER PULSES
10p	1E	1		1		1
20p	2E	1		2		2
50p	3E	1		6	1 bonus credit	5
1£	4E	1		15	5 bonus credits	10



In the above example (UK currency), the cost of a credit is set to 10p and each game costs 3 credits (for a total of 30p). This method allows game cost to be increased by the smallest unit of currency used (e.g. increasing the cost of Solitaire to four (4) credits would increase the game cost by 10p).

In both examples, note that meter pulses are independent of credits and only track the unit of currency (10p in the examples). Players are given an incentive to deposit more money by giving them “bonus” credits for depositing 50p or £1. Coins may be deposited in any combination of values and the game will automatically register the highest number of credits for the total amount of coins deposited. Once a game is played, any remaining fractional credits are erased.

Generally, most countries have a factory default setting. This setting can be adjusted (as described above), but will return if the game memory is cleared. Some programs, depending on the key used, have a CURRENCY DEFAULT DISPLAY located to the left of the coin inputs. It shows the currency value for each of the coin inputs. This display is used as a guide and is not used in any calculations. Touch the CURRENCY DEFAULT DISPLAY to hide/show the display.

**To Enter This Screen Touch “Display Books” At The Setup Screen**



Figure 4 - Books Screen

The books screen displays the current and lifetime credit totals for each game, as well as the percentage of credits played per game (the percentage for each game is the total number of credits played on that game divided by the total number of credits entered into the machine).

Touching a game name will display the current and lifetime credit totals, broken into 1 Player, 2 Player and Linked Games. It also shows the “shortest,” “longest” and “average” playing times for that game (only “link-only” games, like Pile-On, are included in time calculations; time calculations for games that can be played as link or amusement are only displayed for the amusement version).



Figure 5 - Books Screen w/ Time Inset

Touch CLEAR CURRENT to erase all current book data.

**NOTE: TOUCHING TRIVIA WHIZ OR POWER QUIZ DISPLAYS TOTALS BY CATEGORY.**

**Megatouch™ EZ MAXX Video Billboard Operating Instructions**

**Video Billboard Icon Functions:**

The Megatouch™ EZ MAXX Video Billboard allows for six, separate advertising screens. Two of the screens can only be accessed using “Six Stars” (and are intended for use by the location owner), the other four screens are accessed using the Video Billboard icon located on the System Settings screen.

The Video Billboard provides several font styles, sizes and colors, a choice of background colors and designs, as well as a variety of clip art. The basic Video Billboard screen is shown below, followed by the operating instructions. A maximum of 16 screen objects (a line of text or a piece of clip art) can be placed on any given screen.



Figure 6 – Video Billboard Screen with Keyboard

To access the Video Billboard, enter the System Settings screen and touch the VIDEO BILLBOARD icon to display the video billboard keyboard screen.

Callout #	Screen Icon	Description
1	Timer	Allows the user to set the amount of time the given screen is displayed during the idle mode. The timer can be set from 0 to 20 seconds, in 5 second increments. (Setting the timer to zero (0) will prevent the screen from being displayed. This is helpful when designing a screen that you do not want to display immediately, but do want to store in the game's memory for use at a later date.)
2	Full Screen	Allows the user to view a full screen preview of the designed screen. While in "full screen", graphics and text can be repositioned by selecting them and then touching the new location.
3	Clear Ad	Allows the user to erase the entire design for the displayed screen. This icon changes to "DELETE" if any screen object is selected (when an object is selected, a box appears around the object.)
4	Screen X	Touching this icon toggles through each of the video billboard screens (where "X" is the number of the screen.)
5	Fonts	Touching this icon displays the font formatting icons on the bottom half of the screen. These icons allow the user to select from 4 styles of font, 3 font sizes and 8 colors. The screen also has controls for alignment: right, left and centered. To format the font, select the desired text and then touch the font style, size, color and/or alignment (if you have more than one line of text on the screen, you will need to repeat this action for each line of text.) Touching the KEYBOARD icon will return you to the keyboard screen.
6	Background	This icon toggles the background design through each of the 20 preset backgrounds.

Callout #	Screen Icon	Description
7	Clip Art	This icon displays the clip art selection windows on the bottom half of the screen. From here, the user can select clip art to be used on the displayed screen. Use the scroll bar at the bottom of the screen to move through the clip art. The clip art size can be adjusted by selecting the piece of clip art and then selecting "SMALL", "MEDIUM", or "LARGE" at the bottom of the screen (if you have more than one piece of clip art on the screen, you will need to repeat this action for each piece of clip art.) Once the clip art is displayed on the screen, touching the desired clip art and sliding your finger to the location where you want it placed can move it. Touching the KEYBOARD icon will return you to the keyboard screen.
8	Exit	Exits the user to the System Settings screen.
9	Keyboard	The keyboard is used for entering all text onto the displayed screen. Once text is displayed on the screen, touching the text and sliding your finger to the location where you want the text can move it. The cursor can be moved to a new location by touching the desired location.

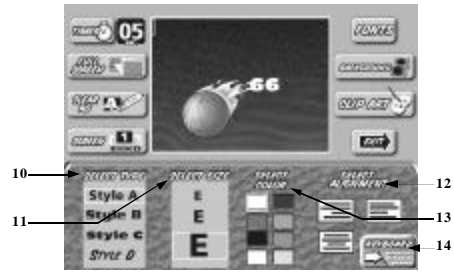

Figure 7 - Video Billboard Screen with Font Controls

Callout #	Screen Icon	Description of Function
10	Select Type	Touch to change font type (choose from 4 font styles.)
11	Select Size	Touch to change font size (choose from 3 size options.)
12	Select Alignment	Touch to set font alignment (left, right or centered.)
13	Select Color	Touch to change font color (choose from 8 colors.)
14	Keyboard	Displays the keyboard.



Figure 8 - Video Billboard Screen with Clip Art Controls

Callout #	Screen Icon	Description of Function
15	Clip Art	Touch a clip art window to select (choose from 33 pieces of clip art.)
16	Select Size	Touch to change clip art size (choose from 3 sizes.)
17	Scroll Bar	Touch the arrows to scroll through clip art.
18	Keyboard	Displays the keyboard.

**Merit Industries, Inc.**  
**Troubleshooting Guide for *Megatouch™ MAXX Games***

Refer to the list below if you are experiencing a problem with your Megatouch™ EZ MAXX Game...

PROBLEM	CORRECTIVE ACTION	COMMENT
<b>No Power, Game reboots/monitor seems to power cycle</b>	<ul style="list-style-type: none"> <li>• Check that the power cord is connected to a "live outlet."</li> <li>• Check that the power switch is turned "ON."</li> <li>• Check that the power cord is connected to the game power supply.</li> <li>• Check that the power supply's voltage select switch is set to the proper voltage.</li> </ul>	<ul style="list-style-type: none"> <li>• "Live outlet" is an outlet powered with electricity.</li> <li>• The power switch is located in the rear of the game.</li> <li>• The power cord is plugged into the power supply inside the game.</li> </ul>
<b>No Video.</b>	<ul style="list-style-type: none"> <li>• Check that the game is powered and turned "ON."</li> <li>• Check that the monitor is connected to the game motherboard.</li> <li>• Check that the power is connected to the monitor and the motherboard.</li> <li>• Make sure the RAM DIMM is properly seated.</li> </ul>	<ul style="list-style-type: none"> <li>• See "<b>No Power</b>" under "PROBLEM."</li> <li>• The monitor connection is located inside the rear compartment of the game.</li> <li>• The monitor is powered from a connection on the game power harness, located in the CPU section on countertops.</li> </ul>
<b>Touchscreen does not work. (Microtouch)</b>	<ul style="list-style-type: none"> <li>• Verify that the touchscreen controller is connected to power.</li> <li>• Verify that the touchscreen controller is operating.</li> <li>• Verify that the touchscreen controller is connected to the motherboard.</li> <li>• Make sure the screen is not scratched.</li> <li>• Make sure no metal is touching the screen.</li> <li>• Check COM1 setting during boot-up.</li> <li>• Check for proper ground.</li> </ul>	<ul style="list-style-type: none"> <li>• The touchscreen controller is a small box mounted inside the rear compartment of the game. On a game with a Microtouch controller, an LED is illuminated when power is applied. When operating, the LED will change intensity when the screen is touched.</li> <li>• Check for proper connection of the touchscreen power lead with the power harness. The connection is made near the controller in the CPU section of the game.</li> <li>• If the screen is scratched, it must be replaced.</li> <li>• The touchscreen is connected to COM 1 input on the motherboard in the CPU section of the game.</li> <li>• If COM 1 is bad, the motherboard needs to be replaced.</li> </ul>
<b>Poor picture quality.</b>	<ul style="list-style-type: none"> <li>• Adjust <i>Brightness, Contrast, Horizontal, and Vertical</i> controls.</li> </ul>	<ul style="list-style-type: none"> <li>• Monitor controls are located in the CPU section of the game.</li> </ul>
<b>"NO SOUND DRIVER," "INVALID KEY."</b>	<ul style="list-style-type: none"> <li>• Make sure that the riser card is correctly installed and seated.</li> </ul>	<ul style="list-style-type: none"> <li>• Riser card is the printed circuit board connecting the I/O board to the motherboard. Riser card must be fully inserted in the socket.</li> </ul>

**Merit Industries, Inc.**  
**Troubleshooting Guide for *Megatouch™ MAXX Games***

Refer to the list below if you are experiencing a problem with your Megatouch™ EZ MAXX Game...

PROBLEM	CORRECTIVE ACTION	COMMENT
"ERROR - INVALID KEY"	<ul style="list-style-type: none"> <li>Check the Dallas Key. Verify that it is installed, not damaged and seated tight.</li> <li>Bad I/O riser connection.</li> </ul>	<ul style="list-style-type: none"> <li>The Dallas Key is the button-shaped disc with a spoon handle located on the I/O board.</li> </ul>
Game locks up, Game graphics incorrect.	<ul style="list-style-type: none"> <li>Perform two-button memory clear.</li> </ul>	<ul style="list-style-type: none"> <li>Two-Button Clear:                             <ol style="list-style-type: none"> <li>Turn game power off.</li> <li>Depress and hold the <i>Calibrate</i> and <i>Set-Up</i> buttons located on the connector board in the CPU section in countertops.</li> <li>With <i>Calibrate</i> and <i>Set-Up</i> depressed, turn game power on.</li> <li>Release <i>Calibrate</i> and <i>Set-Up</i> buttons when "2-Button Clear Detected" is displayed on screen.</li> <li>"2-Button Clear Complete."</li> </ol> </li> </ul>
No sound, Game volume low.	<ul style="list-style-type: none"> <li>Adjust volume control.</li> <li>Make sure speaker harness is plugged in.</li> <li>Sound harness is disconnected or damaged.</li> </ul>	<ul style="list-style-type: none"> <li>Speaker harness is connected at J9 on I/O board.</li> <li>Hedaphone jack of sound harness is connected at PL101 on the motherboard and the other end of the sound harness connects to J11 on the I/O board.</li> </ul>
Game volume loud, Sound distorted.	<ul style="list-style-type: none"> <li>Turn volume down.</li> </ul>	<ul style="list-style-type: none"> <li>The volume controls can be accessed through the System Settings screen in the EZ MAXX Setup software.</li> </ul>
Operating system not found	<ul style="list-style-type: none"> <li>Ribbon cable from hard drive to motherboard is loose.</li> </ul>	<ul style="list-style-type: none"> <li>Make sure each end of the ribbon cable is securely in place.</li> </ul>
Meter not advancing.	<ul style="list-style-type: none"> <li>Check connection at I/O board.</li> </ul>	<ul style="list-style-type: none"> <li>Check wiring at J3 METER connector on I/O board in the CPU section of the game.</li> </ul>
"COIN JAM," A continuous tone emits from the game.	<ul style="list-style-type: none"> <li>Check for coin(s) jammed in coin mech.</li> <li>If the game emits the coin jam indicator sound when powered up, the NORMALLY CLOSED contacts of the coin mechanism are being used. The NORMALLY OPEN contacts must be used.</li> </ul>	<ul style="list-style-type: none"> <li>Unlock the rear door of the game to gain access to the coin mech.</li> </ul>



**Megatouch™ EZ MAXX Countertop Parts and Images**

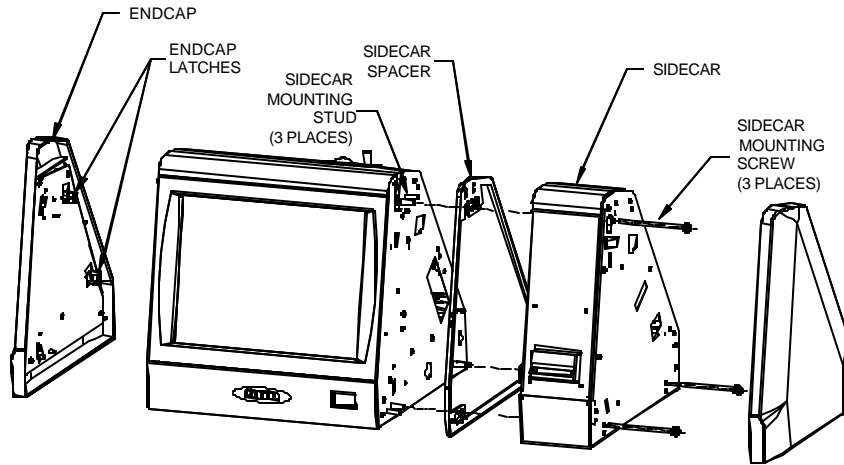

FIGURE 9 - SIDECAR INSTALLATION

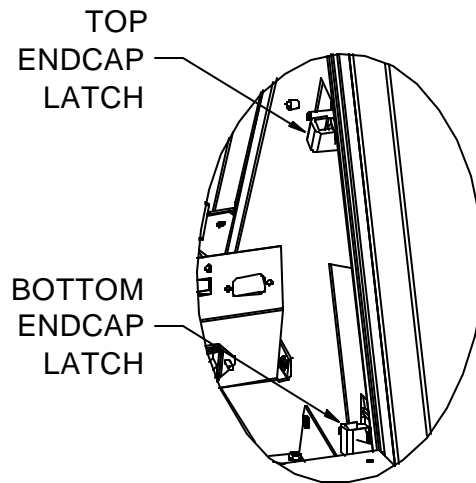

FIGURE 10 - ENDCAP LATCHES

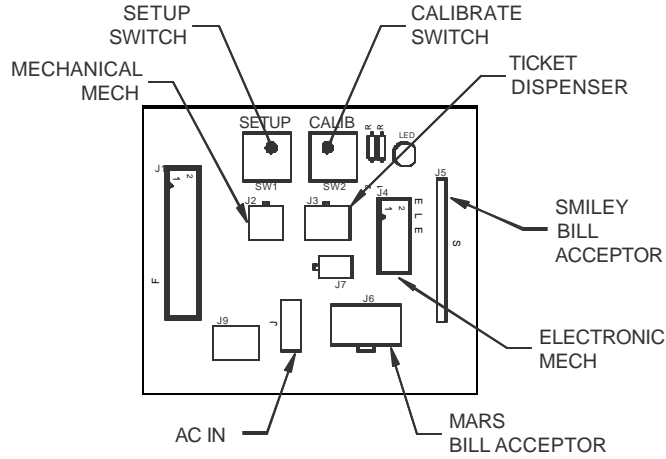

FIGURE 11 - EZ MAXX CONNECTOR BOARD

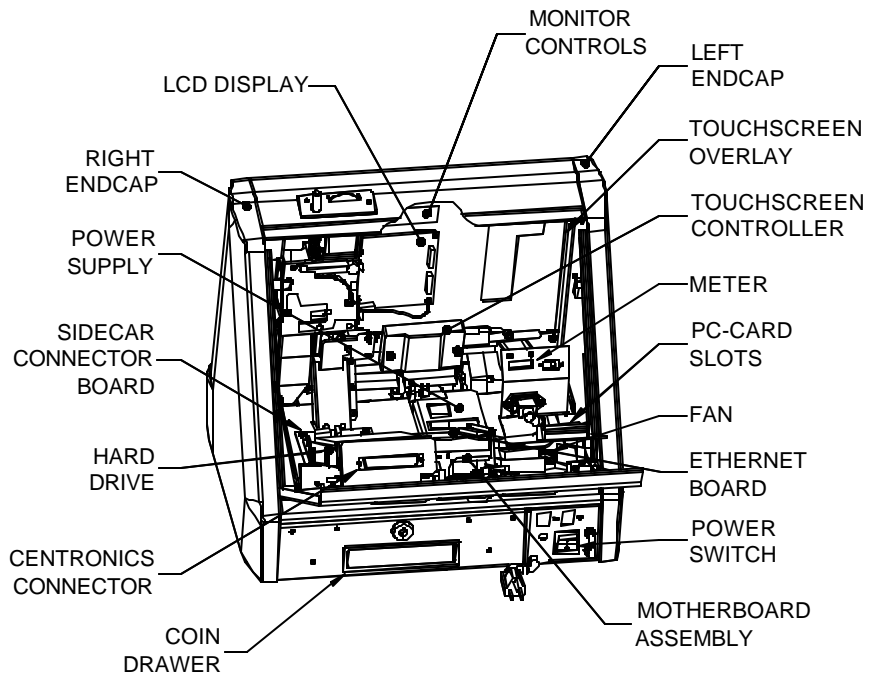

FIGURE 12 - EZ MAXX CPU SECTION (REAR VIEW)

**Megatouch™ EZ MAXX Countertop Replacement Parts List**

EZ MAXX COUNTERTOP	
PART #	DESCRIPTION
<b>SA0217-01</b>	<b>PCB/HDD SHELF ASSEMBLY</b>
SA0200-04	STANDARD HARD DRIVE ASSEMBLY
SA10043-02	PCA, CENTRONICS CONNECTOR BOARD
EC2191-09	RIBBON CABLE, 2X20 PIN, IDE, 12"L
EC0026-03	586 MITSUBISHI MOTHERBOARD W/AUDIO
EC0028-02	MITSUBISHI TWO-SLOT RISER BOARD
SA10051-01	I/O BOARD
SA0200-04	HARD DRIVE ASSEMBLY
<b>SA0235-02</b>	<b>15" DISPLAY</b>
EC9381-01	15" DISPLAY, LCD, XGA
EC9840-03	TOUCHSCREEN CONTROLLER, SMT3E, 26"
EC9850-01	15", TOUCHSCREEN OVERLAY, W/12" CAB
HW8067	TAPE, FOAM, .50W, .03THK, BLACK
<b>LOCKS</b>	
HW8733-05	COIN DRAWER LOCK
HW8721	REAR DOOR LOCK
SA10052-01	PCA CONNECTOR BOARD
SA0239-01	FAN ASSEMBLY
MP0001-01	LEFT ENDCAP
MP0001-02	RIGHT ENDCAP
GL3102-01	EZ MAXX DECALS
EC2001	USA POWER CORD
EC2002	EUROPEAN POWER CORD
EC7529-01	POWER SUPPLY

For additional assistance, after contacting your distributor, contact:

**Merit Product Support and Services**

USA and Canada call toll-free:

**1-800-445-9353**

Outside the USA and Canada call:

**(215) 639-4700**

**FAX: (215) 639-5346**

Merit Industries, Inc. P.O. Box 5004, Bensalem, PA 19020-8529

You can also visit our website

[www.meritind.com](http://www.meritind.com)

## Merit Video Machine Limited Warranty

Merit Industries, Inc. warrants its video machines to be free from defects in material and workmanship for a period of one year from the date of purchase. The warranty covers all electrical components (except fuses and light bulbs) and printed circuit boards. Other items are covered by warranty periods offered by the original equipment manufacturers.

Failure due to misuse, vandalism, excessive or intentional abuse, operation outside specified conditions (including, but not limited to, improper electrical power source), fire, water damage, acts of God, acts of war and civil unrest are specifically excluded.

Merit products are carefully inspected and thoroughly tested prior to packing and shipment. Any damage discovered upon receipt of goods, whether obvious or concealed, must be reported immediately to the delivering carrier and claims made directly to them. Merit assumes no responsibility for damages once the product has left its facilities and any disputes regarding transportation damage must be resolved with the shipping company(s).

Merit will repair or replace, at its option, any component, part or assembly that fails under warranty, provided that the failed item is returned, shipping charges prepaid, to Merit's repair facility and Merit is notified of the failure within the warranty period. Merit reserves the right to request the serial numbers of the item and/or game which has failed, and copies of sales invoices, bills of lading or other documents as required to determine the validity of the warranty coverage. Merit will return or replace warranty items, as specified above, shipping charges prepaid, by ground transportation.

Merit's obligation shall be limited to repair or replacement as stated above, and shall specifically exclude any liability for consequential damages or loss of earnings.

Merit may, at its discretion, provide replacement parts under warranty prior to receiving defective items, without incurring any ongoing obligation to extend such accommodations.

In certain instances, due to geographical or other considerations, Merit may offer PCB warranty service on an extended time basis as follows:

(a) User notifies Merit in writing (or FAX) of PCB failure, providing dates of failure, serial numbers and a brief description of failure symptoms.

(b) Failed PCBs are accumulated for a time period or quantity accumulation, as designated by Merit and sent in one shipment to save shipping expenses.

(c) Merit honors warranty as per dates of failure notification.

The above terms and conditions constitute the sole obligation, written or implied, of Merit Industries under its warranty coverage.



