

HEIL HAM RADIO



**Parametric Receive Audio System Equalizer (PRAS EQ)
& Heil Powered Speaker (HPS-5)**

Power supply not included.

Parametric Receive Audio System Equalizer (PRAS EQ)

The Heil Parametric Receive Audio System Equalizer (PRAS EQ) is a state-of-the-art audio processor that enhances the internal audio systems of amateur radio, shortwave, commercial, and CB receivers. The PRAS EQ allows radio operators to modify, shape, and improve the audio output of their receivers using three separate equalization controls.



Dimensions: 10.25"W x 2.5"H x 8.5"D
Weight: 3.30 lbs

Parametric Equalization Controls

Midrange frequencies are the most critical for achieving clear voice articulation in receive audio. The PRAS EQ allows operators to have unique control over these important frequencies. First, operators can adjust the parametric midrange filter (MID FREQUENCY) from 400 Hz through 4 kHz, with the recommended sweet spot being at 2.5 kHz. In addition, operators can control the level of these midrange frequencies plus or minus 15 dB using the MID GAIN control. Combined with a low frequency filter (LOW) set at 160 Hz, and a high frequency filter (HIGH) set at 6 kHz, the PRAS EQ provides operators unparalleled control and quality of their receive audio. See the following page for recommended Initial Settings, and suggested settings for common receive audio issues.

PRAS EQ Suggested Equalization Control Settings

— The following tables outline common Receive Audio Issues, and provide suggested equalization control settings for each of these issues.

— Every suggested solution is relative to the suggested Initial Settings. Please start your setup with the suggested Initial Settings table, and adjust your PRAS EQ for each receive audio issue relative to these starting settings.

— For each suggested solution, adjust the equalization controls in the suggested order [(1), (2), (3)]. Each subsequent adjustment will be relative to the adjustment before it. Therefore, you might find that only one or two suggested adjustments are necessary in some instances.

— Each suggested solution is just a starting point for common receive audio issues. Adjust the equalization controls up or down thereafter depending on the characteristics of your receive audio signal and your personal preferences.

	HIGH	MID	LOW
Initial Settings	12 o'clock	Level: 2.5 kHz mark Mid gain: 12 o'clock	12 o'clock

Receive Audio Issues	HIGH	MID	LOW
Poor articulation, Speech clarity	(2) Increase level (2 o'clock)	(1) Increase level (2.5 kHz - 4 kHz range) Increase Mid gain (3 o'clock)	(3) Decrease level (10 o'clock)
Boomy, bassy, muddy	(2) Increase level (3 o'clock)	(3) Increase level (2.5 kHz - 4 kHz range) Increase Mid gain (if necessary)	(1) Decrease level (8 o'clock)
Harsh, noisy, static	(1) Decrease level (10 o'clock)	(3) Decrease level (1 kHz - 2 kHz range) Decrease Mid gain (if necessary)	(2) Increase level (2 o'clock)
Thin, weak	(3) Decrease level (if necessary)	(2) Increase Mid gain (2 o'clock) Increase level (if necessary)	(1) Increase level (3 o'clock)
Signal overload (Overload LED on, or VU meter in red) [Adjust EQ after decreasing input level]	(3) Decrease level (if necessary)	(2) Decrease Mid gain (10 o'clock) Decrease level (if necessary)	(1) Decrease level (8 o'clock)

Audio In Connections

The PRAS EQ has three audio inputs to connect to your receiver's output:

- Standard 1/8"
- Standard XLR
- 8 ohm

Included with the PRAS EQ is an 1/8"-to-1/8" male cable, and an 1/8"-to-1/4" adapter. The recommended method is to use this cable to connect the external speaker output of your receiver to the 1/8" audio input of the PRAS EQ. When connecting, reduce the receiver AF output to 10 o'clock or lower. Alternatively, the PRAS EQ can be connected via the audio out pins of the DIN connector in the accessory jack on your receiver's rear panel. Check your receiver operation manual for assistance with your receiver's audio outputs. The speaker output of your receiver can also be connected to the PRAS EQ 8 ohm input.

Audio Out Connections

The PRAS EQ has three audio outputs to connect to external audio devices:

- Balanced XLR (rear panel)
- Mono 1/4" (rear panel)
- 1/8" Recording audio (front panel)

The PRAS EQ is intended to be used with the Heil HPS-5 powered speaker (the PRAS EQ must be used with a powered speaker). The HPS-5 consists of a 24-watt, two-way, low-distortion amplifier using a midrange tweeter and a 5" low-frequency speaker. The HPS-5, in combination with the PRAS EQ, provides superb audio balance without distortion.

The PRAS EQ also comes with an 1/8" output on the front panel to connect to any external recording device to record receive audio.

Headphone Outputs

Two independent headphone amplifiers are included in the PRAS EQ, each with its own 1/8" output and level control. Headphone outputs do not bypass the external audio out connections. For independent left or right audio levels for your headphones use the Heil Independent Headphone Splitter (PRAS HP Y) *sold separately. The splitter uses a single channel from each headphone output, which gives the user level control between the left and right speakers of your headphones.

PRAS EQ Audio Input/Output Diagram

PRAS EQ Rear Panel

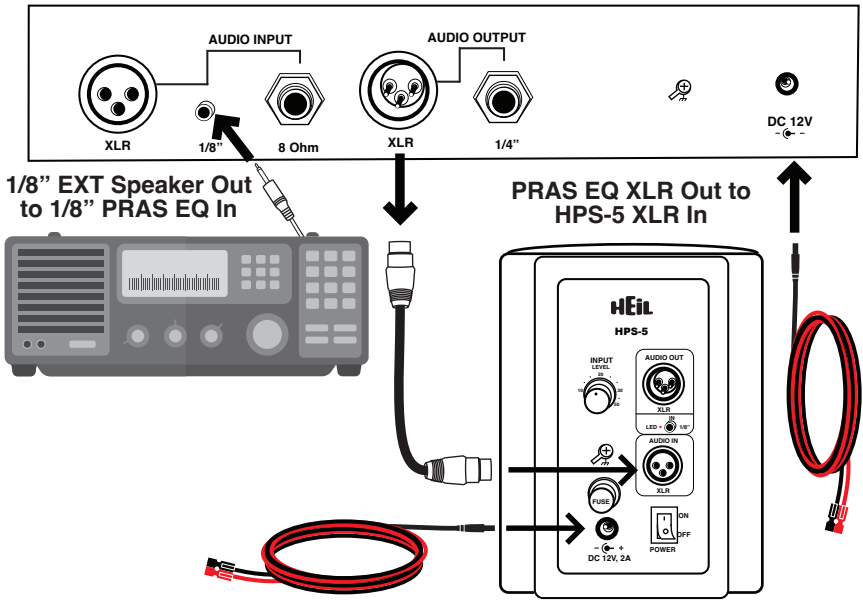

PRAS EQ Front Panel

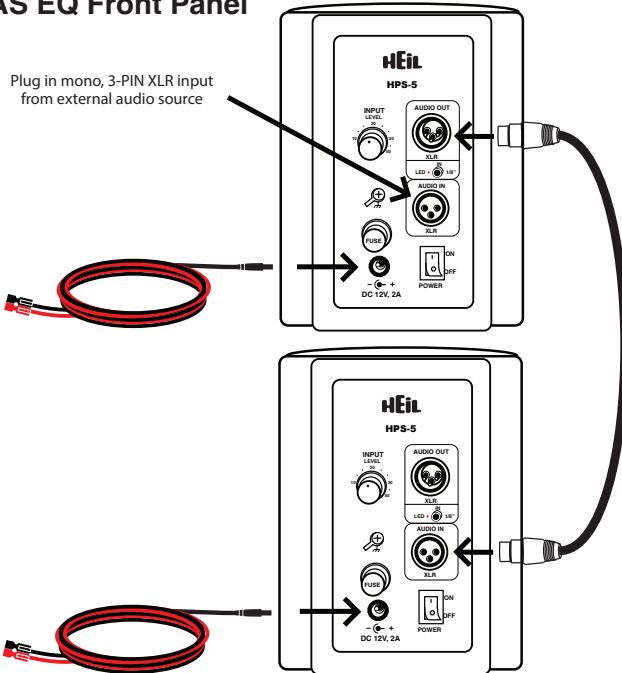

VU Meter and Overload LED

The VU meter on the PRAS EQ takes into account all four parametric equalization controls as well as input level. Therefore, the VU meter will not necessarily track input level as measured by any external device. The overload LED is more susceptible to input level and the LOW frequencies of the parametric equalization controls. As such, there are times where the VU meter might indicate overload (in the red), but the overload LED does not, and vice versa. If overload occurs in either case, reduce input level first, then adjust equalization controls as suggested on p.2.

Power Supply Adapter

The PRAS EQ is powered by a 12-volt, 2 amp DC power supply (not included). A 2.5 mm barrel to powerpole adapter cable is supplied.

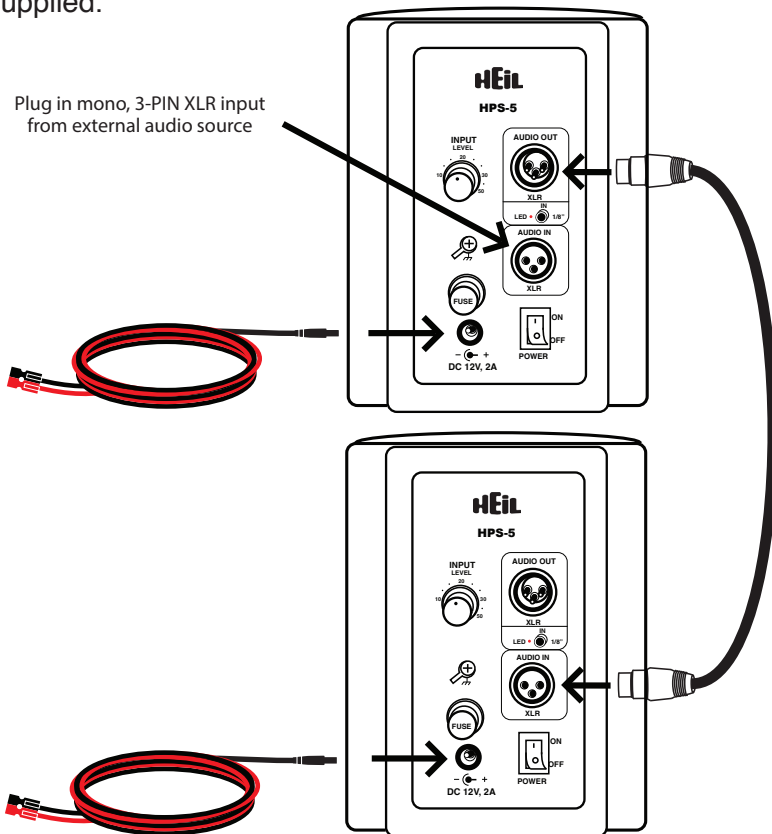

Note: The HPS-5 speaker is not meant to be used with a microphone plugged directly into the speaker.

HPS-5 - Heil Powered Speaker with 5" Driver

The Heil Powered Speaker (HPS-5) is a two-way, powered speaker designed to be used with the Heil Parametric Receive Audio System Equalizer (PRAS EQ). The HPS-5 in combination with the PRAS EQ provides unmatched speech articulation and brings new dimensions to receive audio quality. The end result is a fantastic listening experience that relieves ear fatigue for operators.

The HPS-5 has a low-distortion, highly efficient Class A 24-watt amplifier that drives a specially designed 5" low-frequency speaker mounted in a resonant sealed enclosure. A passive extended crossover drives a 2" high-frequency tweeter.

The HPS-5 has two rear panel inputs: a balanced 600 ohm XLR input and an unbalanced 1/8" input. A single level control adjusts the input signals for both inputs. There is also a balanced 600 ohm XLR output for combining two or more HPS-5 powered speakers. To use an extension/secondary speaker simply plug a 3 pin XLR out of the primary speaker to the XLR input of the extension speaker. In order to send audio from the primary speaker to the secondary speaker, the power must be on the primary speaker. The volume level of these speakers can be matched or independent. These will not function as stereo speakers.

The HPS-5 is powered by a 12-volt, 2 amp DC power supply (not included). A 2.5 mm barrel to powerpole adapter cable is supplied as well as a 2 amp fuse that is mounted on the rear panel.



Dimensions: 7.25"W x 9.5"H x 7"D
Weight: 5.85 lbs

If you have any questions regarding the use of your Parametric Receive Audio System Equalizer (PRAS EQ) or Heil Powered Speaker (HPS-5) please contact Heil Sound directly.

All in and out of warranty items returned must be accompanied by a completed repair form, which can be found at:
<https://www.heilhamradio.com/repairs>

Heil Sound Communications, Inc. warrants these products to the original purchaser for a period of one year parts and 90 days labor from the date of purchase. It does not cover accidental or intentional damage. Heil Sound is not responsible for loss, damage or expenses that arise from the use or the inability to use this product.

Heil Sound Suggested Accessories

