

## AIMB-290

**Intel® Atom® C3000 processor  
with DDR4 ECC/non-ECC RAM,  
VGA, Dual GbE, Dual 10GbE,  
PCIe x8, DC/ATX Input**

---

## Copyright

The documentation and the software included with this product are copyrighted 2018 by Advantech Co., Ltd. All rights are reserved. Advantech Co., Ltd. reserves the right to make improvements in the products described in this manual at any time without notice.

No part of this manual may be reproduced, copied, translated or transmitted in any form or by any means without the prior written permission of Advantech Co., Ltd. Information provided in this manual is intended to be accurate and reliable. However, Advantech Co., Ltd. assumes no responsibility for its use, nor for any infringements of the rights of third parties, which may result from its use.

## Acknowledgements

IBM and PC are trademarks of International Business Machines Corporation.

Intel® ATOM C3000 is trademark of Intel Corporation

All other product names or trademarks are properties of their respective owners.

## Product Warranty (2 years)

Advantech warrants to you, the original purchaser, that each of its products will be free from defects in materials and workmanship for two years from the date of purchase.

This warranty does not apply to any products which have been repaired or altered by persons other than repair personnel authorized by Advantech, or which have been subject to misuse, abuse, accident or improper installation. Advantech assumes no liability under the terms of this warranty as a consequence of such events.

Because of Advantech's high quality-control standards and rigorous testing, most of our customers never need to use our repair service. If an Advantech product is defective, it will be repaired or replaced at no charge during the warranty period. For out-of-warranty repairs, you will be billed according to the cost of replacement materials, service time and freight. Please consult your dealer for more details.

If you think you have a defective product, follow these steps:

1. Collect all the information about the problem encountered. (For example, CPU speed, Advantech products used, other hardware and software used, etc.) Note anything abnormal and list any onscreen messages you get when the problem occurs.
2. Call your dealer and describe the problem. Please have your manual, product, and any helpful information readily available.
3. If your product is diagnosed as defective, obtain an RMA (return merchandise authorization) number from your dealer. This allows us to process your return more quickly.
4. Carefully pack the defective product, a fully-completed Repair and Replacement Order Card and a photocopy proof of purchase date (such as your sales receipt) in a shippable container. A product returned without proof of the purchase date is not eligible for warranty service.
5. Write the RMA number visibly on the outside of the package and ship it prepaid to your dealer.

# A Message to the Customer

## Advantech Customer Services

Each and every Advantech product is built to the most exacting specifications to ensure reliable performance in the harsh and demanding conditions typical of industrial environments. Whether your new Advantech equipment is destined for the laboratory or the factory floor, you can be assured that your product will provide the reliability and ease of operation for which the name Advantech has come to be known.

Your satisfaction is our primary concern. Here is a guide to Advantech's customer services. To ensure you get the full benefit of our services, please follow the instructions below carefully.

## Technical Support

We want you to get the maximum performance from your products. So if you run into technical difficulties, we are here to help. For the most frequently asked questions, you can easily find answers in your product documentation. These answers are normally a lot more detailed than the ones we can give over the phone.

So please consult this manual first. If you still cannot find the answer, gather all the information or questions that apply to your problem, and with the product close at hand, call your dealer. Our dealers are well trained and ready to give you the support you need to get the most from your Advantech products. In fact, most problems reported are minor and are able to be easily solved over the phone.

In addition, free technical support is available from Advantech engineers every business day. We are always ready to give advice on application requirements or specific information on the installation and operation of any of our products.

# Declaration of Conformity

## FCC Class B

This device complies with the requirements in part 15 of the FCC rules:

Operation is subject to the following two conditions:

- This device may not cause harmful interference
- This device must accept any interference received, including interference that may cause undesired operation.

This equipment has been tested and found to comply with the limits for a Class B digital device, pursuant to Part 15 of the FCC Rules. These limits are designed to provide reasonable protection against harmful interference when the equipment is operated in a commercial environment. This equipment generates, uses, and can radiate radio frequency energy and, if not installed and used in accordance with the instruction manual, may cause harmful interference to radio communications. Operation of this device in a residential area is likely to cause harmful interference in which case the user will be required to correct the interference at his/her own expense. The user is advised that any equipment changes or modifications not expressly approved by the party responsible for compliance would void the compliance to FCC regulations and therefore, the user's authority to operate the equipment.

**Caution!** *There is a danger of a new battery exploding if it is incorrectly installed. Do not attempt to recharge, force open, or heat the battery. Replace the battery only with the same or equivalent type recommended by the manufacturer. Discard used batteries according to the manufacturer's instructions.*



## CPU Compatibility

CPU Family	Core Stepping	Cores	Power	Freq (GHz)	Cache	Mfg. Tech	HT	VT-x	VT-d	Package Type	Result
Intel ATOM C3958	QS	16	31W	2.00 GHz	16 MB	14 nm	NO	YES	YES	FCBGA1310	PASS
Intel ATOM C3858	QS	12	25 W	2.00 GHz	12 MB	14 nm	NO	YES	YES	FCBGA1310	PASS
Intel ATOM C3758	QS	8	25 W	2.20 GHz	16 MB	14 nm	NO	YES	YES	FCBGA1310	PASS
Intel ATOM C3558	QS	4	16 W	2.20 GHz	8 MB	14 nm	NO	YES	YES	FCBGA1310	PASS

## Memory Compatibility

Category	ECC	Speed	Capacity	Vendor	ADVANTECH P/N	Module/Chip_PN
Long-DIMM DDR4	N	2400	4GB	Advantech	SQR-UD4N4G2K4HNEAC	H5AN4G8NAFR
Long-DIMM DDR4	N	2400	8GB	ADATA	AQD-D4U8GN24-HE	H5AN8G8NAFR
Long-DIMM DDR4	N	2400	8GB	Advantech	SQR-UD4N8G2K4HNEAC	H5AN8G8NAFR
Long-DIMM DDR4	N	2133	8GB	ADATA	N/A	H5AN4G8NMFR TFC
Long-DIMM DDR4	N	2133	16GB	Advantech	AQD-D4U16N21-SE	SEC 543 K4A8G08 5WB BCPB
Long-DIMM DDR4	N	2133	16GB	Transcend	N/A	SEC 546 K4A8G08 5WB BCRC
Long-DIMM DDR4	N	2400	16GB	ADATA	AQD-D4U16N24-HE	H5AN8G8NAFR
Long-DIMM DDR4	ECC	2400	8GB	ADATA	AQD-D4U8GE24-HE	H5AN8G8NAFR
Long-DIMM DDR4	ECC	2133	16GB	Advantech	AQD-D4U16E21-SE	SEC 546 K4A8G08 5WB BCPB
Long-DIMM DDR4	ECC	2400	16GB	Advantech	SQR-UD4M-16G2K4SEB	SEC 649 K4A8G08 5WB BCRC
Long-DIMM DDR4	ECC	2400	16GB	Advantech	AQD-D4U16E24-SE	SEC 649 K4A8G08 5WB BCRC
Long-DIMM DDR4	ECC	2400	16GB	ADATA	AQD-D4U16E24-HE	H5AN8G8NAFR
Long-DIMM DDR4	ECC	2400	32GB	Advantech	SQR-RD4M-32G2K4SRB	SEC 637 K4A8G04 5WB BCRC

## Ordering Information

P/N	CPU	VGA	GbE LAN	10GbE	COM	SATA	USB3.0/2.0	MiniPCIe	TPM	PCIEx8	IPMI
AIMB-290G4-S1A1E	C3958	1	2	2	2	6	3/1	1 F/S	(1)	1	Yes
AIMB-290G4-S2A1E	C3758	1	2	2	2	6	3/1	1 F/S	(1)	1	Yes
AIMB-290G2-S3A1E	C3558	1	2	0	2	6	3/3	1 F/S	(1)	0	NA

\*( ) BOM options available on MP version.

## Initial Inspection

Before you begin installing your motherboard, please make sure that the following materials have been shipped:

- 1X AIMB-290 Mini-ITX Motherboard
- 4 x SATA HDD cable
- 1 X SATA power cable
- 1 x COM port cable
- 1 x I/O port bracket
- 1 x Startup manual
- 1 x Warranty card
- 1 x CPU cooler

If any of these items are missing or damaged, contact your distributor or sales representative immediately. We have carefully inspected the AIMB-290 mechanically and electrically before shipment. It should be free of marks and scratches and in perfect working order upon receipt. As you unpack the AIMB-290, check it for signs of shipping damage. (For example, damaged box, scratches, dents, etc.) If it is damaged or it fails to meet the specifications, notify our service department or your local sales representative immediately. Also notify the carrier. Retain the shipping carton and packing material for inspection by the carrier. After inspection, we will make arrangements to repair or replace the unit.

---

## Precautions

1. Please use either EATXPWR1 or ATX12V1. Do not use both connectors at the same time.
2. The temperature of the 10GbE LAN IC is high due to its high performance. When you assemble the enclosure with AIMB-290, please make sure the system fan can remove heat efficiently from the chassis, or the customer can purchase a suitable compatible cooler from Advantech.

# Contents

## Chapter 1 General Information .....1

1.1	Introduction .....	2
1.2	Features .....	2
1.3	Specifications .....	2
1.3.1	System .....	2
1.3.2	Memory .....	2
1.3.3	Input/Output .....	2
1.3.4	Graphics.....	3
1.3.5	Ethernet LAN .....	3
1.3.6	Industrial Features .....	3
1.3.7	Mechanical and Environmental Specifications.....	3
1.4	Jumpers and Connectors .....	3
	Table 1.1: Jumpers.....	3
	Table 1.2: Connectors .....	4
1.5	Board layout: Jumper and Connector Locations .....	5
	Figure 1.1 Jumper and Connector Location .....	5
	Figure 1.2 I/O Connectors .....	5
1.6	AIMB-290 Board Diagram .....	6
	Figure 1.3 AIMB-290 Block Diagram .....	6
1.7	Safety Precautions .....	6
1.8	Jumper Settings .....	7
1.8.1	How to Set Jumpers.....	7
1.9	System Memory .....	7
1.10	Memory Installation Procedures.....	7
1.11	Processor .....	7

## Chapter 2 Connecting Peripherals .....9

2.1	Introduction .....	10
2.2	USB Ports (USB0304 / USB0506 / Lan5_USB0102 / JUSBPWR1) .....	10
	Table 2.1: USB0102 (Lan5_USB0102) .....	10
	Table 2.2: USB0304 .....	11
	Table 2.3: USB0506 .....	11
	Table 2.4: JUSBPWR1 for USB0102 / USB0304 .....	11
2.3	LAN Ports (LAN12 / LAN34 / LAN5_USB0102) .....	12
	Table 2.5: Lan12.....	12
	Table 2.6: Lan34.....	13
	Table 2.7: Lan5 (LAN5_USB0102).....	13
2.4	VGA Port (VGA1) .....	13
	Table 2.8: VGA1 .....	14
2.5	Serial Ports (COMD1 / COM2).....	14
	Table 2.9: COMD1.....	14
	Table 2.10: COM2 .....	15
2.6	Front Panel Connectors (JFP1+JFP2 / JFP3).....	15
	Table 2.11: JFP1+JFP2.....	15
	Table 2.12: JFP3 .....	16
2.6.1	ATX Soft Power Switch (JFP1/PWR_SW).....	16
2.6.2	Reset (JFP1/RESET).....	16
2.6.3	HDD LED (JFP1/HDDLED).....	16
2.6.4	External speaker (JFP1/SPEAKER) .....	16
2.6.5	Power LED and keyboard lock connector (JFP3/PWR_LED & KEY LOCK).....	16
	Table 2.13: ATX Power Supply LED Status (No support for AT power) .....	16

2.7	GPIO / SMBUS / PMBUS (GPIO1 / SMBUS1 / PM BUS1) .....	17
2.7.1	PMBUS .....	17
	Table 2.14: GPIO1 .....	17
	Table 2.15: SMBUS1 .....	17
	Table 2.16: PMBUS1 .....	17
2.8	SPI Programming Pin Header (SOC-BIOS2, BMC-BIOS2) / Battery Holder (BAT1).....	18
	Table 2.17: SOC-BIOS2, BMC-BIOS2 .....	18
	Table 2.18: BAT1 .....	18
2.9	Serial ATA (SATA1 / SATA2 / SATA3 / SATA4 / SATA5 / SATA6), Serial ATA Power connectors (SATAPWR1).....	19
	Table 2.19: SATA1~ SATA6 .....	19
	Table 2.20: SATAPWR1.....	19
2.10	Fan Connector (CPUFAN1/SYSFAN1/SYSFAN2/SYSFAN3/SYSFAN4) ..	20
	Table 2.21: CPUFAN1.....	20
	Table 2.22: SYSFAN1/ SYSFAN2/ SYSFAN3/ SYSFAN4 .....	20
2.11	PS/2 Keyboard and Mouse Connector (KBMS1).....	21
	Table 2.23: KBMS1 .....	21
2.12	ATX/AT Mode Selection (PSOEN1).....	22
	Table 2.24: PSOEN1 .....	22
2.13	System Error LED Connector (SYS_LED) / NETWORK LED Pin Header (LANLED1).....	23
	Table 2.25: SYS_LED .....	23
	Table 2.26: LANLED1 .....	23
2.14	Case-Open Detect Connector (JCASE1).....	24
	Table 2.27: JCASE1 .....	24
2.15	Power Connector (EATXPWR1, ATX12V1).....	25
	Table 2.28: EATXPWR1.....	25
	Table 2.29: ATX12V1 .....	26
2.16	PCI Express x8 Slot (PCIEX8_1).....	26
	Table 2.30: PCIEX8_1.....	27
2.17	MINIPCIE / mSATA Connector (MINIPCIE1).....	28
	Table 2.31: MINIPCIE1 .....	28

## **Chapter 3 BIOS Operation ..... 31**

3.1	Introduction .....	32
3.2	BIOS Setup .....	32
3.2.1	Main Menu .....	33
3.2.2	Advanced BIOS Features .....	34
3.2.3	Chipset Configuration Setting .....	52
3.2.4	Server Mgmt .....	63
3.2.5	Event Logs.....	68
3.2.6	Security.....	70
3.2.7	Boot .....	71
3.2.8	Save & Exit .....	72

## **Chapter 4 Software Introduction & Service ..... 75**

4.1	Introduction .....	76
4.2	Value-Added Software Services .....	76
4.2.1	Software API.....	76
4.2.2	Software Utility.....	77

## **Chapter 5 Chipset Software Installation Utility 79**

5.1	Before You Begin.....	80
-----	-----------------------	----



5.2	Introduction .....	80
5.3	Windows Server 2016 Driver Setup .....	80



# Chapter 1

General Information

---

## 1.1 Introduction

AIMB-290 is designed with the Intel Atom C3000 series for server applications that require both performance computing and enhanced system/power management capabilities.

The motherboard supports C3958 2.0 GHz / C3758 2.2 GHz/ C3558 2.2 GHz, support ECC/non-ECC DDR4 long DIMM up to 64GB/32GB, per slot up to 32GB/16GB. And connectivity of 2 x serial ports, 3 x USB 3.0, 1/3 x USB 2.0, dual GbE LAN, dual 10GbE LAN, 2 x SATA III ports. AIMB-290 also supports IPMI 2.0 (Intelligent Platform Management Interface).

## 1.2 Features

- **High performance:** Use Intel ATOM C3000 processor up to 16 core SOC. Supports ECC DDR4 long DIMM up to 64GB.
- **IPMI 2.0:** The AIMB-290 supports IPMI 2.0 to manage and control server systems.
- **Fast network:** 2 ports 10GbE LAN to strengthen Internet transmission.
- **EMMC inside:** Supports EMMC 5.1.
- **Power design for application:** AIMB-290 supports DC 12V 4-pin only or ATX 24-pin input independently.

## 1.3 Specifications

### 1.3.1 System

- **CPU/Chipset:** Intel ATOM C3000 series processor
- **BIOS:** AMI EFI 128 Mbit SPI BIOS
- **SATA hard disk drive interface:** 6 on-board SATA connectors with data transmission rates up to 600 MB

### 1.3.2 Memory

- **RAM:** 2 slots with 288-pin long-DIMM. Supports dual-channel DDR4 1600/1866/2133/2400MHz ECC/Non-ECC SDRAM.
  - 16GB/per DIMM for DDR4 non-ECC/ECC 2400MHz with U-DIMM.
  - 32GB/per DIMM for DDR4 ECC 2400MHz with R-DIMM.

### 1.3.3 Input/Output

- **PCIe slot:** One PCIe x8 expansion slot, 1 x full-size MiniPCIe
- **Serial port:** Two serial ports, one is RS-232/422/485 and one is RS-232. One DB-9 connector located in rear panel is RS-232.
- **Keyboard and PS/2 mouse connector:** One 6-pin mini-DIN connector
- **USB port:** Supports 3 x USB 3.0 ports with transmission rates up to 5Gbps, and 1 or 3 x USB 2.0 ports (sku) with transmission rates up to 480 Mbps.
- **GPIO:** Supports 8-bit GPIO for general purpose control applications.

### 1.3.4 Graphics

- **Controller:** ASPEED AST2500/2510 BMC controller
- **Display memory:** 4 GB DDR4 on board
- **VGA:** Supports max. resolution 1920 x 1200 @ 60 Hz

### 1.3.5 Ethernet LAN

- **Interface:** 10/100/1000/10G Mbps
- **Controller:**
  - LAN 1/2: Marvell 88E1512 with RJ45 for 10/100/1GbE
  - LAN 3/4: Intel X557-AT2 with RJ45 for 1G/10GbE (sku)
  - Lan5: IPMI controller, Realtek RTL8201 with RJ45 for IPMI (sku)

### 1.3.6 Industrial Features

- **Watchdog timer:** Can generate a system reset. The watchdog timer is programmable, with each unit equal to one second or one minute (255 levels)

### 1.3.7 Mechanical and Environmental Specifications

- **Operating temperature:** 0 ~ 60° C (32 ~ 140° F, depending on CPU)
- **Storage temperature:** -40 ~ 85° C (-40 ~ 185° F)
- **Humidity:** 5 ~ 95% non-condensing
- **Power supply voltage:** Only DC 12V with 4-pin connector or +3.3 V, +5 V, +12 V, -12 V, +5VSB with ATX 24-pin connector
- **Power consumption:** 35W with Intel ATOM C3958 + 1x 32GB RAM + 1x 64GB SSD
- **Board size:** 170 x 170 mm
- **Board weight:** 0.356 kg

## 1.4 Jumpers and Connectors

Connectors on the AIMB-290 motherboard link it to devices such as hard disk drives and a keyboard. In addition, the board has a number of jumpers used to configure your system for your application.

The tables below list the function of each of the board jumpers and connectors. Later sections in this chapter give instructions on setting jumpers. Chapter 2 gives instructions for connecting external devices to your motherboard.

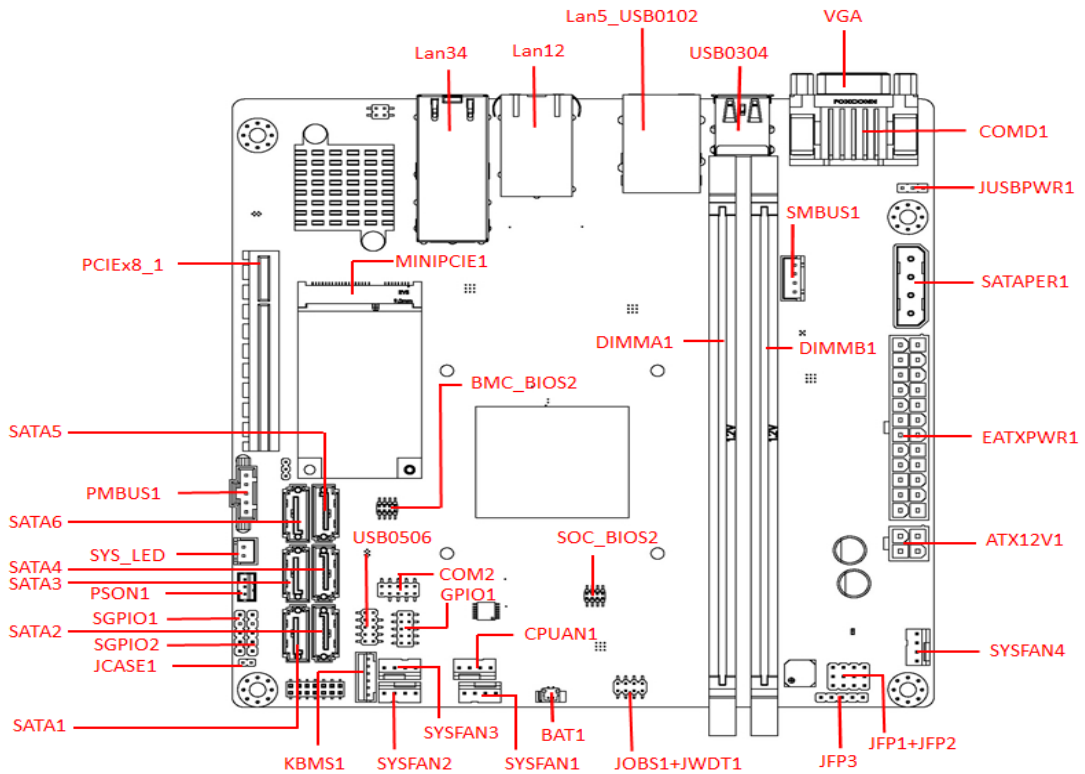
**Table 1.1: Jumpers**

Label	Function
JFP1+JFP2	Front Panel Pin Header
JCMOS1	CMOS Clear Jumper
PSO1	ATX/AT Mode Selection
JUSBPWR1	USB Port Power Selection
JOBS1+JWDT1	Watchdog Timer Output, OBS Beep

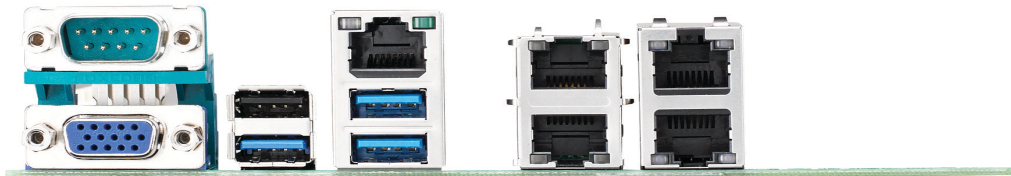
**Table 1.2: Connectors**

<b>Label</b>	<b>Function</b>
DIMMA1, DIMMB1	DDR4 288-pin DIMM Socket
SOC-BIOS2, BMC-BIOS2	SPI Programming Pin Header
SATA1~6	SATA Signal Connector
SATAPWR1	MINIPCIE Connector
PCIEX8_1	PCI-E x8 Slot
LANLED1	NETWORK LED Pin Header
EATXPWR1	ATX Power Supply Connector
ATX12V1	ATX 12V Power Supply Connector
GPIO1	General Purpose I/O Pin Header
USB0506	USB2.0 Pin Header
COM2	COM Port Pin Header
KBMS1	PS/2 Keyboard and Mouse Connector
JFP1+JFP2	Front Panel Pin Header
CPUFAN1	CPU FAN Power Connector
SYSFAN1~4	SYSTEM FAN Power Connector
JFP3	Power LED and Keyboard Lock Pin Header
JCASE1	Case Open Pin Header
SYS_LED	System Error LED Connector
BAT1	Battery Connector
LPC1	Low Pin Count Header
SMBUS1	SM Bus Connector
PMBUS1	Power Supply PM Bus Connector
SGPIO1, SGPIO2	SGPIO Connector

# 1.5 Board layout: Jumper and Connector Locations



**Figure 1.1 Jumper and Connector Location**



**Figure 1.2 I/O Connectors**

## 1.6 AIMB-290 Board Diagram

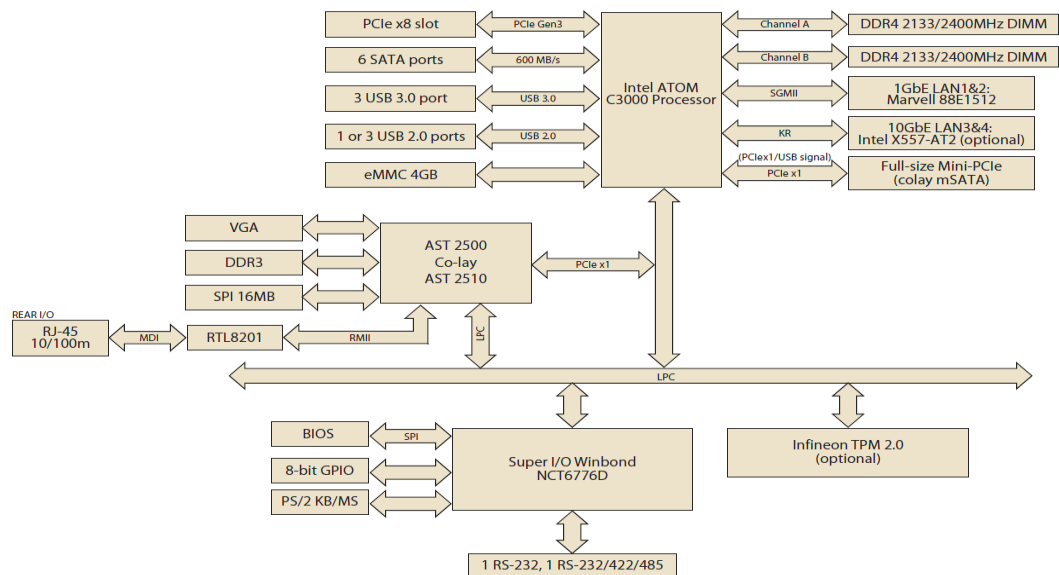


Figure 1.3 AIMB-290 Block Diagram

## 1.7 Safety Precautions

**Warning!** Always completely disconnect the power cord from chassis whenever you work with the hardware. Do not make connections while the power is on. Sensitive electronic components can be damaged by sudden power surges. Only experienced electronics personnel should open the PC chassis.



**Caution!** Always ground yourself to remove any static charge before touching the motherboard. Modern electronic devices are very sensitive to electrostatic discharges. As a safety precaution, use a grounding wrist strap at all times. Place all electronic components on a static-dissipative surface or in a static-shielded bag when they are not in the chassis.



**Caution!** The computer is provided with a battery-powered real-time clock circuit. There is a danger of explosion if battery is incorrectly replaced. Replace only with same or equivalent type recommended by the manufacturer. Discard used batteries according to manufacturer's instructions.



**Caution!** There is a danger of a new battery exploding if it is incorrectly installed. Do not attempt to recharge, force open, or heat the battery. Replace the battery only with the same or equivalent type recommended by the manufacturer. Discard used batteries according to the manufacturer's instructions.





## 1.8 Jumper Settings

This section provides instructions on how to configure your motherboard by setting the jumpers. It also includes the motherboards's default settings and your options for each jumper.

### 1.8.1 How to Set Jumpers

You can configure your motherboard to match the needs of your application by setting the jumpers. A jumper is a metal bridge that closes an electrical circuit. It consists of two metal pins and a small metal clip (often protected by a plastic cover) that slides over the pins to connect them. To “close” (or turn ON) a jumper, you connect the pins with the clip. To “open” (or turn OFF) a jumper, you remove the clip. Sometimes a jumper consists of a set of three pins, labeled 1, 2, and 3. In this case you connect either pins 1 and 2, or 2 and 3. A pair of needle-nose pliers may be useful when setting jumpers.

## 1.9 System Memory

AIMB-290 has two 288-pin memory sockets for 2133/2400 MHz memory modules with maximum capacity of 32/64 GB.

16GB/per DIMM for DDR4 non-ECC/ECC 2400MHz with U-DIMM, and 32GB/per DIMM for DDR4 ECC 2400MHz with R-DIMM.

## 1.10 Memory Installation Procedures

To install DIMMs, first make sure the two handles of the DIMM socket are in the “open” position, i.e., the handles lean outward. Slowly slide the DIMM module along the plastic guides on both ends of the socket. Then firmly but gently (avoid pushing down too hard) press the DIMM module well down into the socket, until you hear a click when the two handles have automatically locked the memory module into the correct position of the DIMM socket. To remove the memory module, just push both handles outward, and the memory module will be ejected by the mechanism.

## 1.11 Processor

The AIMB-290 is designed for FCBGA1310, Intel ATOM C3000 series processor with 12 lanes sku processor.



# Chapter 2

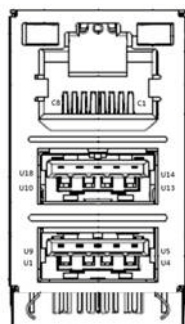
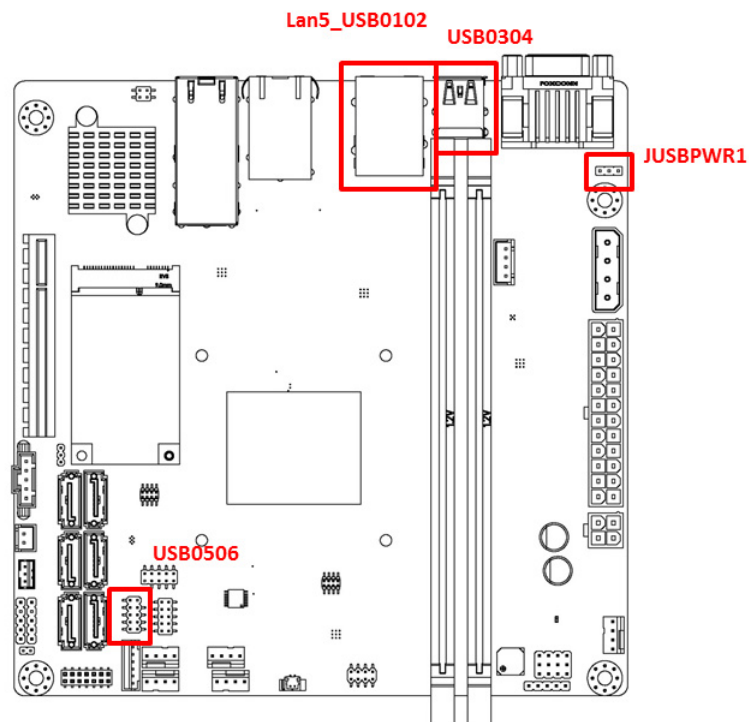
Connecting  
Peripherals

## 2.1 Introduction

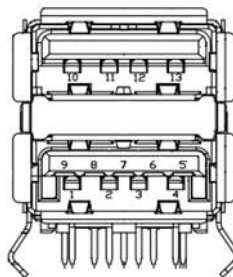
You can access most of the connectors from the top of the board as it is being installed in the chassis. If you have a number of cards installed or have a packed chassis, you may need to partially remove the card to make all the connections.

## 2.2 USB Ports (USB0304 / USB0506 / Lan5\_USB0102 / JUSBPWR1)

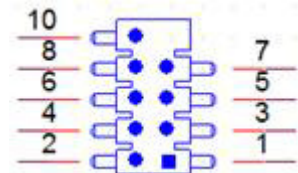
The AIMB-290 provides up to max 6 x USB ports. The USB interface complies with USB Specification Rev 2.0 supporting transmission rates up to 480 Mbps and Rev 3.0 supporting transmission rate up to 5 Gbps and is fuse protected. The USB interface can be disabled in the system BIOS setup.



LAN5\_USB0102



USB0304



USB0506

**Table 2.1: USB0102 (Lan5\_USB0102)**

Pin	Signal	Pin	Signal
U1	+5V	U10	+5V
U2	D1-	U11	D2-

**Table 2.1: USB0102 (Lan5\_USB0102)**

U3	D1+	U12	D2+
U4	GND	U13	GND
U5	RX1-	U14	RX2-
U6	RX1+	U15	RX2+
U7	GND	U16	GND
U8	TX1-	U17	TX2-
U9	TX1+	U18	TX2+

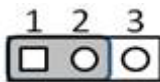
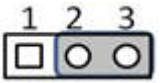
**Table 2.2: USB0304**

Pin	Signal	Pin	Signal
1	+5V	10	+5V
2	D3-	11	D4-
3	D3+	12	D4+
4	GND	13	GND
5	RX3-		
6	RX3+		
7	GND		
8	TX3-		
9	TX3+		

**Table 2.3: USB0506**

Pin	Signal	Pin	Signal
1	+5V Stand by	2	+5V Stand by
3	D6-	4	D5-
5	D6+	6	D5+
7	GND	8	GND
9	N.C.		

**Table 2.4: JUSBPWR1 for USB0102 / USB0304**

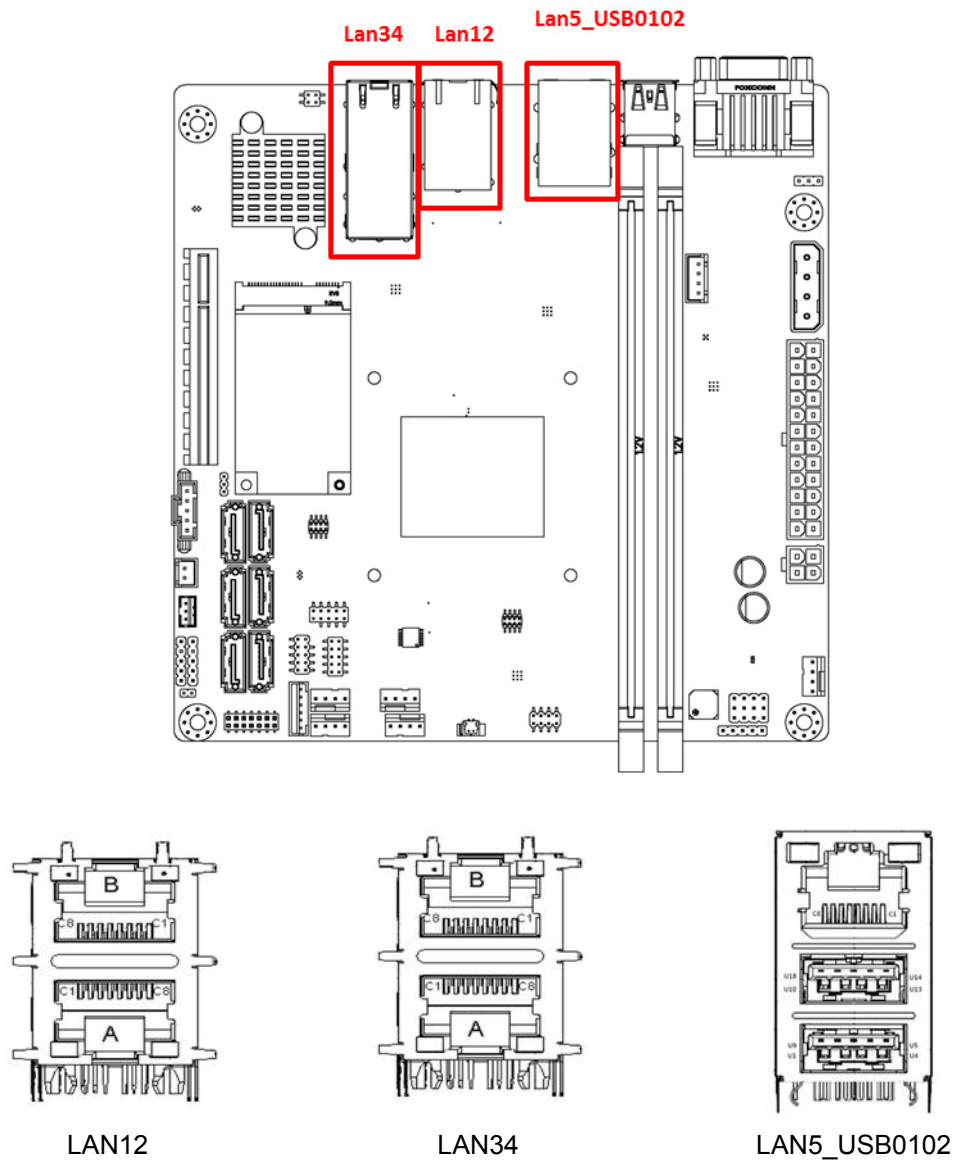
Function	Jumper Setting
+5V Stand by power (1-2) (Default)	
+V5 main power (2-3)	

**Note!** \* Does'nt support USB0506



## 2.3 LAN Ports (LAN12 / LAN34 / LAN5\_USB0102)

The AIMB-290 is equipped with two performance 1000 Mbps and two high-performance 1GbE Ethernet LAN adapters to support by all major network operating systems. The RJ-45 jacks on the rear panel to provides convenient LAN connection.



**Table 2.5: Lan12**

Pin	Signal	Pin	Signal
A-C1	LAN2_MDI_0+	B-C1	LAN1_MDI_0+
A-C2	LAN2_MDI_0-	B-C2	LAN1_MDI_0-
A-C3	LAN2_MDI_1+	B-C3	LAN1_MDI_1+
A-C4	LAN2_MDI_2+	B-C4	LAN1_MDI_2+
A-C5	LAN2_MDI_2-	B-C5	LAN1_MDI_2-
A-C6	LAN2_MDI_1-	B-C6	LAN2_MDI_1-
A-C7	LAN2_MDI_3+	B-C7	LAN2_MDI_3+
A-C8	LAN2_MDI_3-	B-C8	LAN2_MDI_3-

**Table 2.6: Lan34**

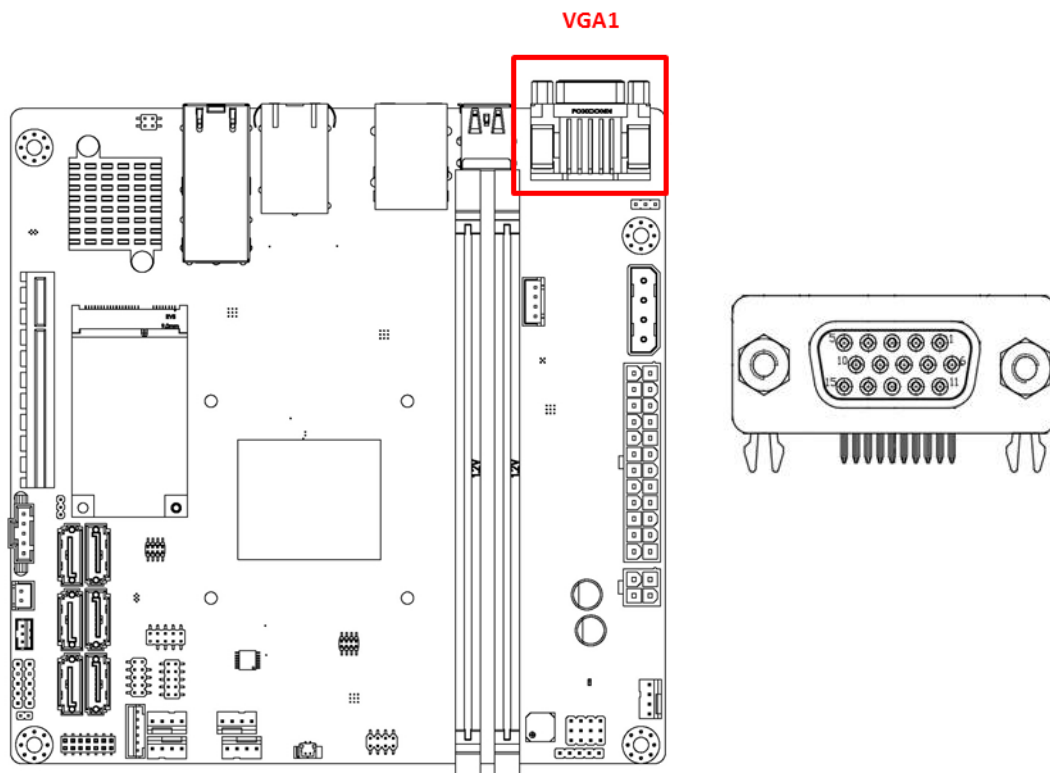
Pin	Signal	Pin	Signal
A-C1	LAN4_MDI_0+	B-C1	LAN3_MDI_0+
A-C2	LAN4_MDI_0-	B-C2	LAN3_MDI_0-
A-C3	LAN4_MDI_1+	B-C3	LAN3_MDI_1+
A-C4	LAN4_MDI_2+	B-C4	LAN3_MDI_2+
A-C5	LAN4_MDI_2-	B-C5	LAN3_MDI_2-
A-C6	LAN4_MDI_1-	B-C6	LAN3_MDI_1-
A-C7	LAN4_MDI_3+	B-C7	LAN3_MDI_3+
A-C8	LAN4_MDI_3-	B-C8	LAN3_MDI_3-

**Table 2.7: Lan5 (LAN5\_USB0102)**

Pin	Signal	Pin	Signal
C1	LAN5_MDI_0+	C5	N.C.
C2	LAN5_MDI_0-	C6	LAN5_MDI_1-
C3	LAN5_MDI_1+	C7	N.C.
C4	N.C.	C8	N.C.

## 2.4 VGA Port (VGA1)

AIMB-290's VGA Port with max resolution supports to 1920x1080 32/16bpp @ 60Hz

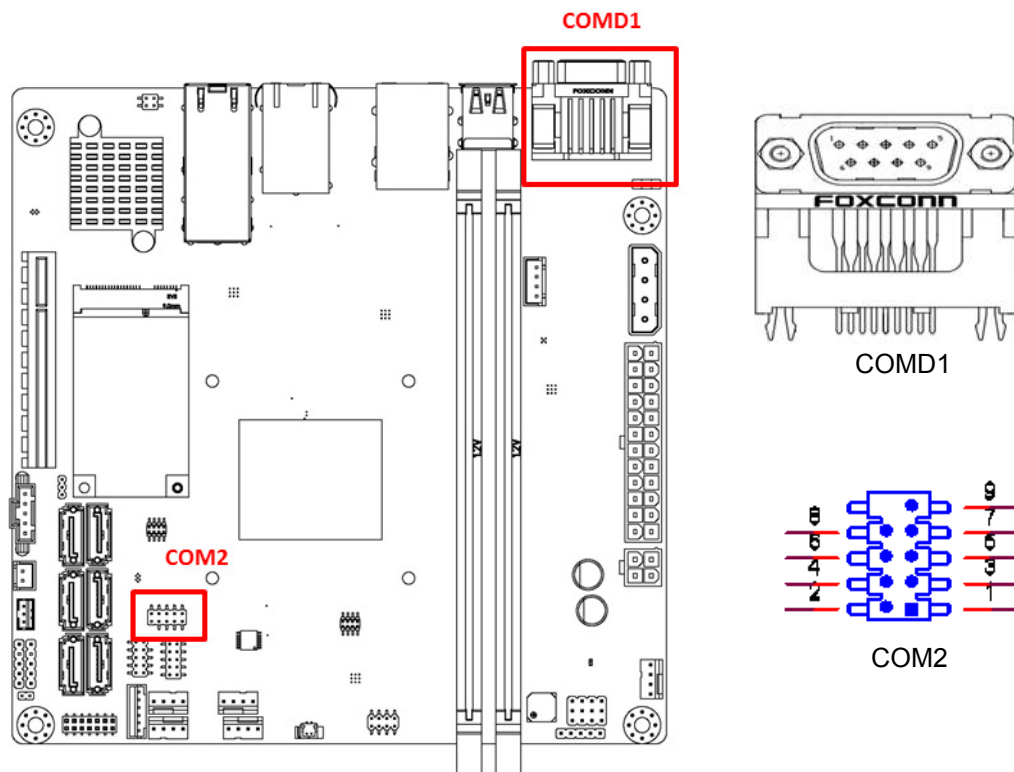


**Table 2.8: VGA1**

Pin	Signal	Pin	Signal
1	RED	9	+5V
2	GREEN	10	GND
3	BLUE	11	N.C.
4	N.C.	12	SDATA
5	GND	13	HSYNC
6	GND	14	VSYNC
7	GND	15	SCLK
8	GND		

## 2.5 Serial Ports (COMD1 / COM2)

AIMB-290 supports two serial ports, COM1 supports RS-232 function, COM2 supports RS-232/422/485 function by BIOS selection. These ports can connect to serial devices, such as a mouse or a printer, or to a communications network. The IRQ and address ranges for both ports are fixed. However, if you want to disable the port or change these parameters later, you can do this in the system BIOS setup. Different devices implement the RS-232 standards in different ways. If you have problems with a serial device, be sure to check the pin assignments for the connector.

**Table 2.9: COMD1**

Pin	Signal	Pin	Signal
1	COM1_DCD#	6	COM1_DSR#
2	COM1_SIN	7	COM1_RTS#
3	COM1_SOUT	8	COM1_CTS#



**Table 2.9: COM1**

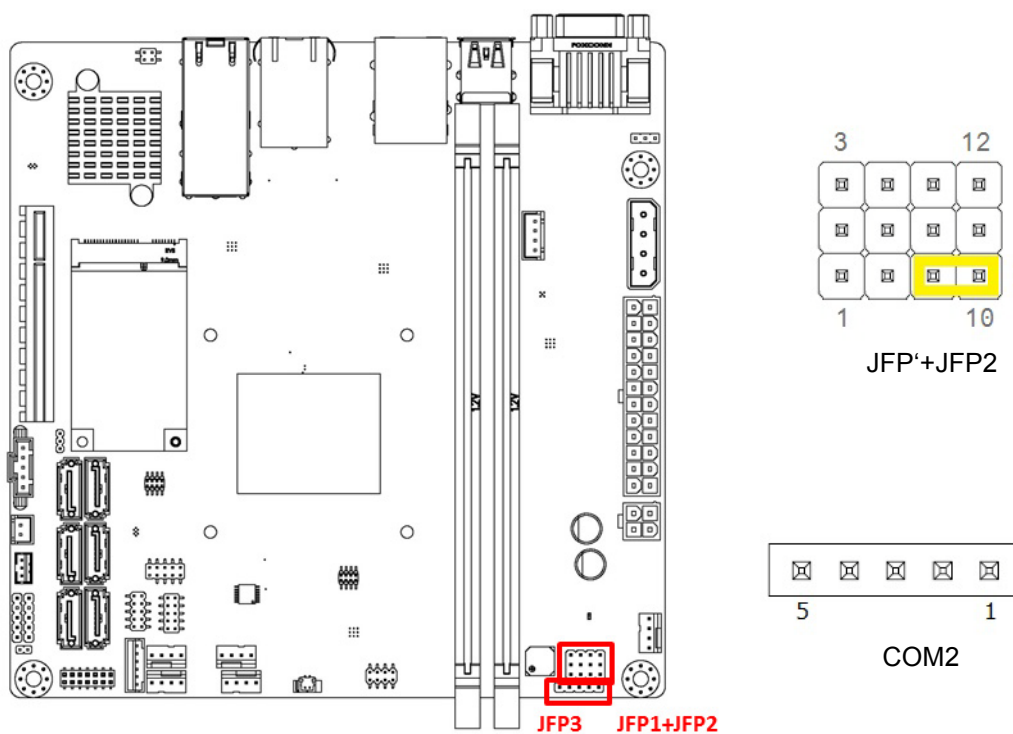
4	COM1_DTR#	9	COM1_RI#
5	GND		

**Table 2.10: COM2**

Pin	Signal	Pin	Signal
1	COM2_DCD#	2	COM2_DSR#
3	COM2_RXD#	4	COM2_RTS#
5	COM2_TXD#	6	COM2_CTS#
7	COM2_DTR#	8	COM2_RI#
9	GND		

## 2.6 Front Panel Connectors (JFP1+JFP2 / JFP3)

There are several headers for monitoring and controlling the AIMB-290.

**Table 2.11: JFP1+JFP2**

Pin	Signal	Pin	Signal
1	+5V	2	HDD LED+
3	Power Button+	4	SPK_P2
5	HDD LED-	6	Power Button-
7	SPK_P3	8	SMB_DATA
9	System Reset+	10	SPK_P4
11	SMB_CLK	12	System Reset-

\* Internal Speaker (Buzzer) (7-10)(Default)

**Table 2.12: JFP3**

Pin	Signal	Pin	Signal
1	PWR LED +	2	NC
3	PWR LED (GND)	4	Keyboard Lock
5	GND		

### 2.6.1 ATX Soft Power Switch (JFP1/PWR\_SW)

If your computer case is equipped with an ATX power supply, you should connect the power on/off button on your computer case to (JFP1/ PWR\_SW), for convenient power on and off.

### 2.6.2 Reset (JFP1/RESET)

Many computer cases offer the convenience of a reset button. Connect the wire for the reset button.

### 2.6.3 HDD LED (JFP1/HDDLED)

You can connect an LED to connector (JFP1/HDDLED) to indicate when the HDD is active.

### 2.6.4 External speaker (JFP1/SPEAKER)

JFP2/SPEAKER (Buzzer) is a 2-pin connector. AIMB-290 don't has external speaker. It provides an onboard buzzer as an alternative. To enable the buzzer, set pins 7 & 10 as closed.

### 2.6.5 Power LED and keyboard lock connector (JFP3/PWR\_LED & KEY LOCK)

(JFP3/PWR\_LED & KEY LOCK) is a 5-pin connector for the power on LED and Key Lock function. Refer to Appendix B for detailed information on the pin assignments.

The Power LED cable should be connected to pin 1-3. The key lock button cable should be connected to pin 4-5. There are 3 modes for the power supply connection. The first is "ATX power mode"; the system turns on/off by a momentary power button. The second is "AT Power Mode"; the system turns on/off via the power supply switch. The third is another "AT Power Mode" which makes use of the front panel power switch. The power LED status is indicated in the following table:

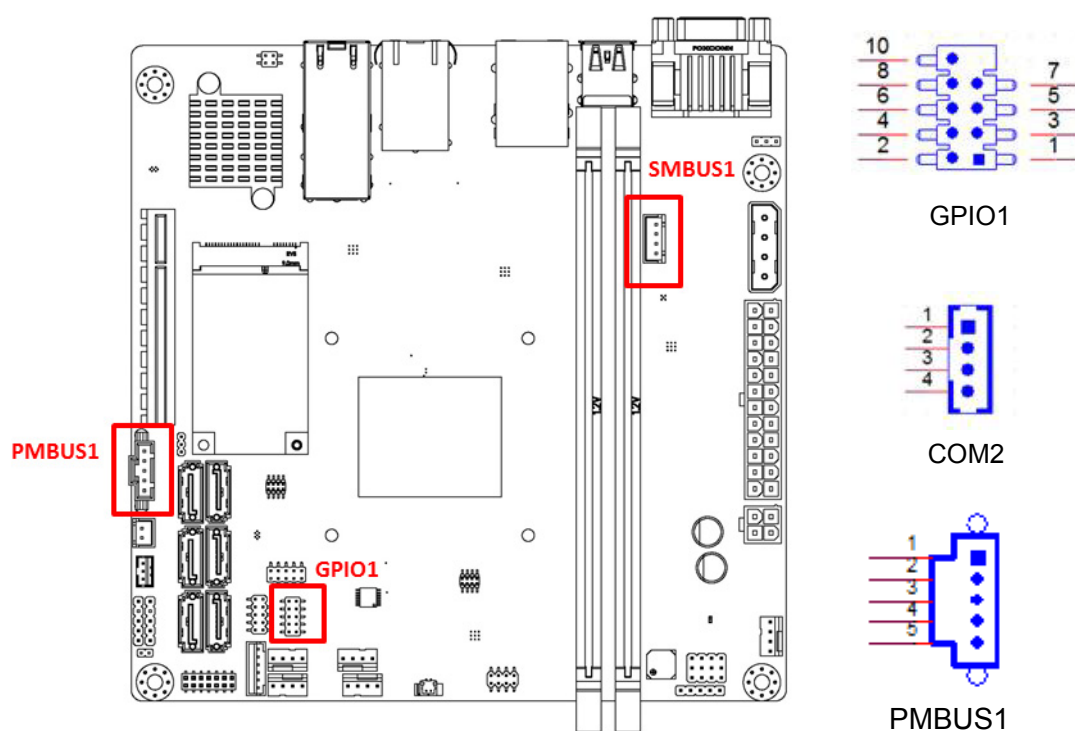
**Table 2.13: ATX Power Supply LED Status (No support for AT power)**

Power mode	LED (ATX Power Mode) (On/off by momentary button)	LED (AT power Mode) (On/off by switching power supply)	LED (AT power Mode) (On/off by front panel switch)
PSON1 (on back plane) jumper setting	pins 2-3 closed	pins 1-2 closed	Connect pins 1 & 2 to panel switch via cable
System On	On	On	On
System Off	Off	Off	Off
S5	NA	N/A	N/A

## 2.7 GPIO / SMBUS / PMBUS (GPIO1 / SMBUS1 / PMBUS1)

### 2.7.1 PMBUS

If power supply can support PMBUS 2.0, you can link this connector to the corresponding connector on power supply to monitor power supply condition. AIMB-290 support basic function, If you want to add more features, please contact with our sale to discuss customized design.



**Table 2.14: GPIO1**

Pin	Signal	Pin	Signal
1	GPIO0	2	GPIO4
3	GPIO1	4	GPIO5
5	GPIO2	6	GPIO6
7	GPIO3	8	GPIO7
9	+5V Stand by	10	GND

**Table 2.15: SMBUS1**

Pin	Signal
1	+5V
2	SMB_CLK
3	SMB_DATA
4	GND

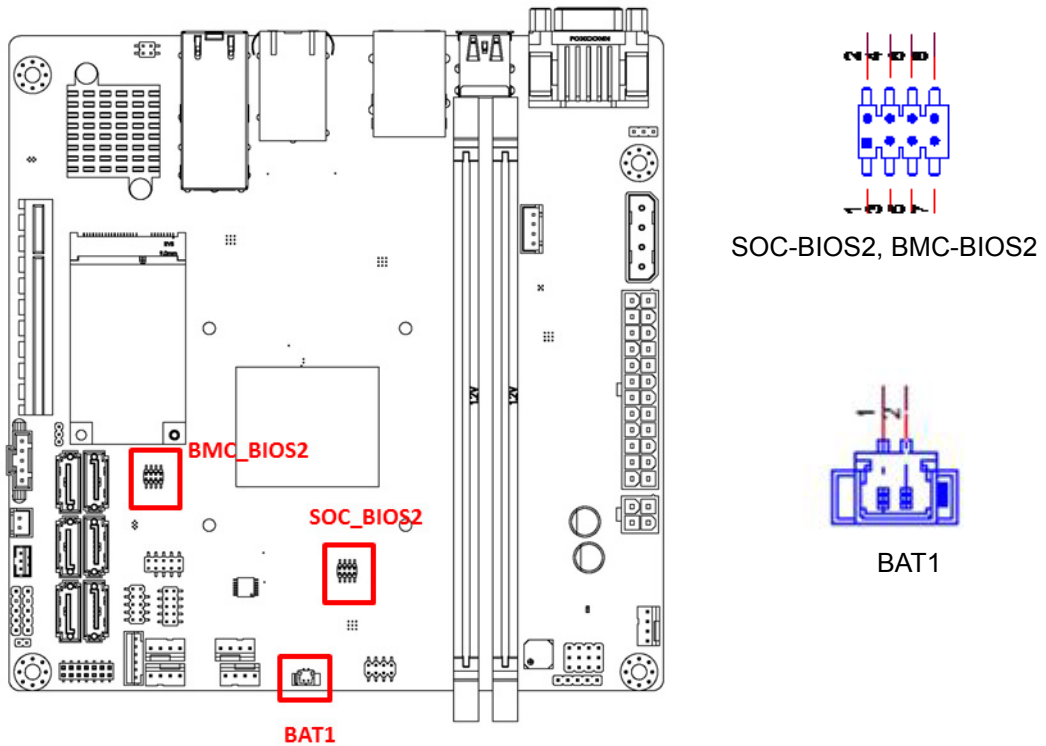
**Table 2.16: PMBUS1**

Pin	Signal
1	SMB_CLK

**Table 2.16: PMBUS1**

2	SMB_DATA
3	SMB_ALERT#
4	GND
5	+V3.3

## 2.8 SPI Programming Pin Header (SOC-BIOS2, BMC-BIOS2) / Battery Holder (BAT1)

**Table 2.17: SOC-BIOS2, BMC-BIOS2**

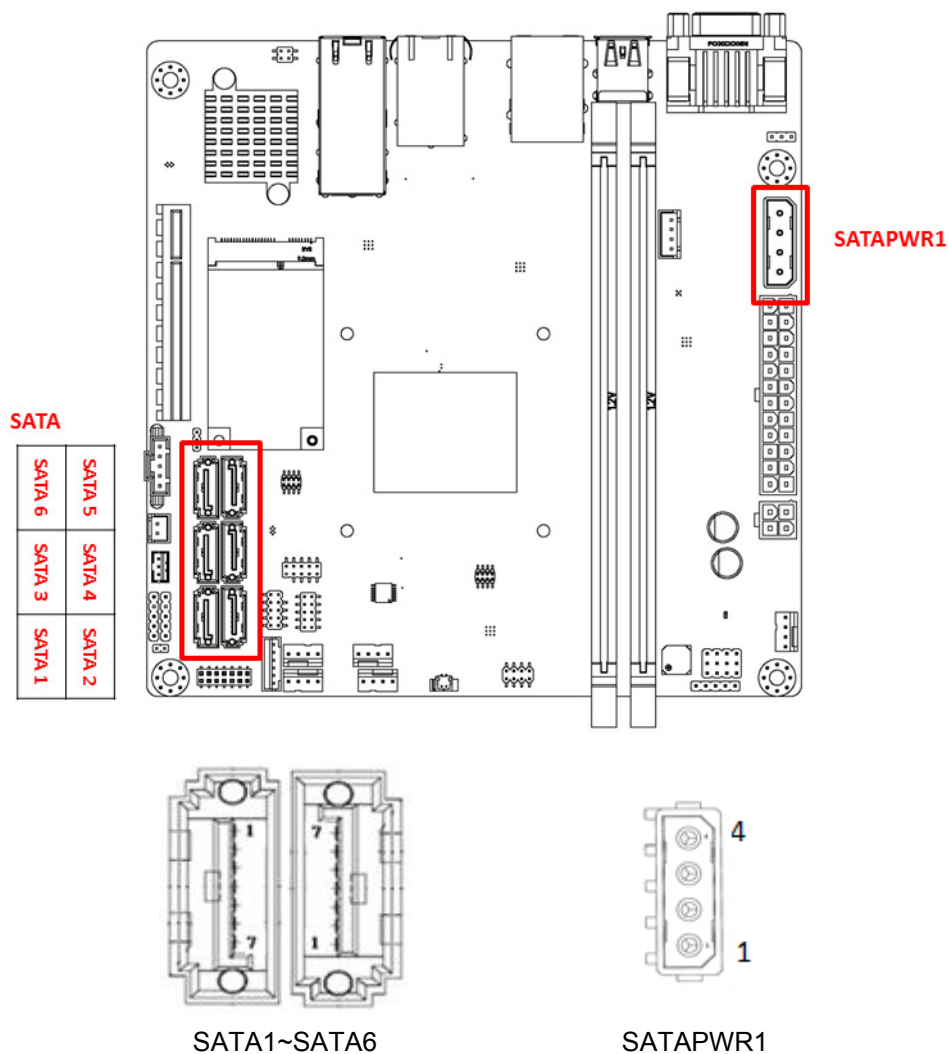
Pin	Signal	Pin	Signal
1	SPISKT_CS#0	2	+3.3V Stand by
3	SPISKT_MISO	4	N.C.
5	N.C.	6	SPISKT_CLK
7	GND	8	SPISKT_MOSI

**Table 2.18: BAT1**

Pin	Signal	Pin	Signal
1	VBAT	2	GND

## 2.9 Serial ATA (SATA1 / SATA2 / SATA3 / SATA4 / SATA5 / SATA6), Serial ATA Power connectors (SATAPWR1)

AIMB-290 features a high performance Serial ATA III interface (up to 600 MB/s) which eases hard drive cabling with thin, space-saving cables.



**Table 2.19: SATA1~ SATA6**

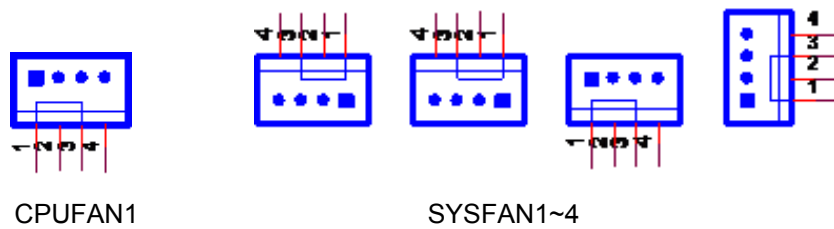
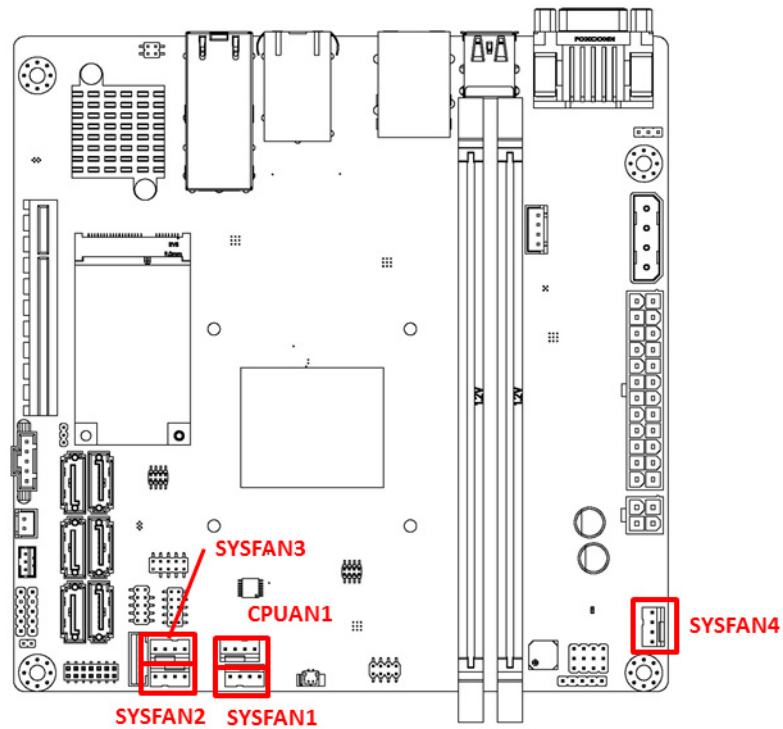
Pin	Signal	Pin	Signal
1	GND	2	TX+
3	TX-	4	GND
5	RX-	6	RX+
7	GND		

**Table 2.20: SATAPWR1**

Pin	Signal	Pin	Signal
1	+12V	2	GND
3	GND	4	+5V

## 2.10 Fan Connector (CPUFAN1/SYSFAN1/SYSFAN2/ SYSFAN3/SYSFAN4)

If a fan is used, this connector supports cooling fans of 500 mA (6 W) or less. Supports smart fan function.



**Table 2.21: CPUFAN1**

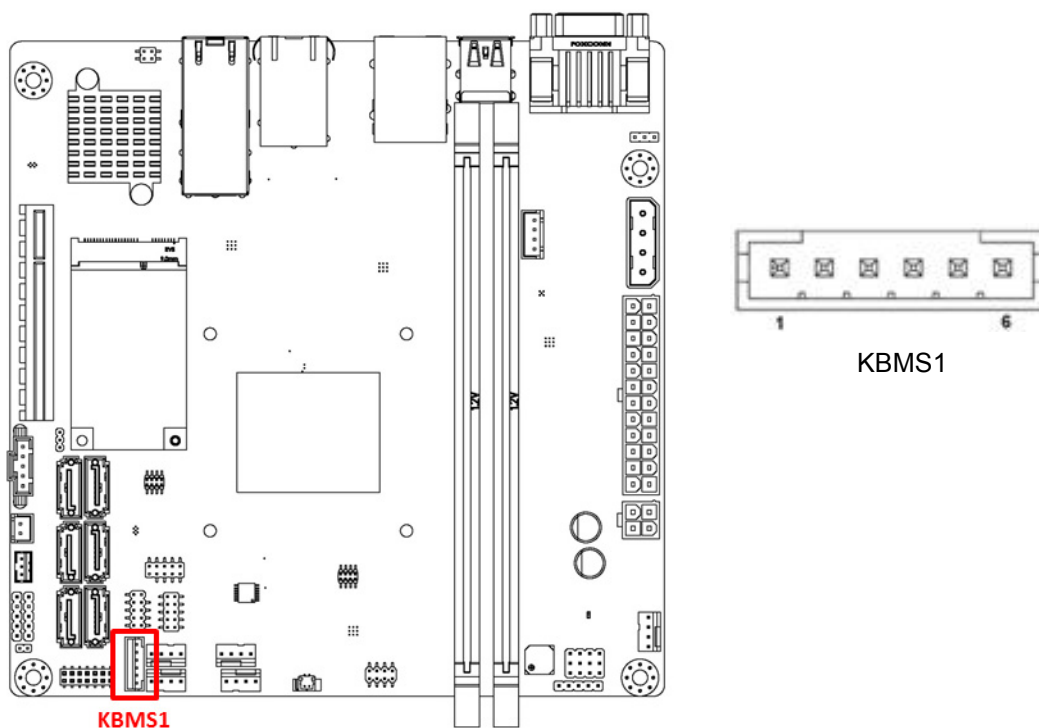
Pin	Signal
1	GND
2	+12V
3	DETECT
4	PWM IN

**Table 2.22: SYSFAN1/ SYSFAN2/ SYSFAN3/ SYSFAN4**

Pin	Signal
1	GND
2	+12V
3	DETECT
4	PWM IN

## 2.11 PS/2 Keyboard and Mouse Connector (KBMS1)

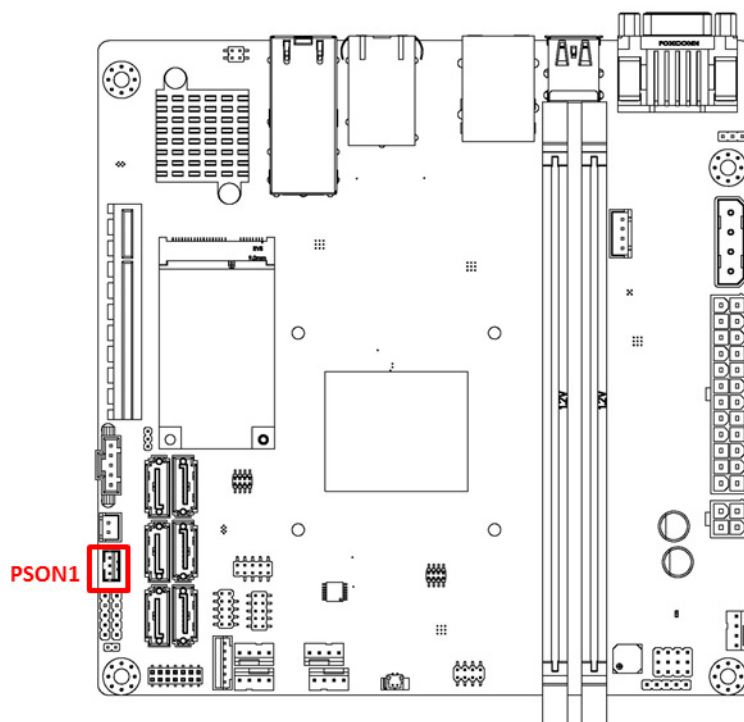
6-pin mini-DIN connectors (KBMS1) is for supporting the PS/2 keyboard and PS/2 mouse by a cable P/N 1703060191.




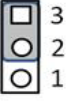
**Table 2.23: KBMS1**

Pin	Signal
1	KB CLK
2	KB DATA
3	MS CLK
4	GND
5	+5V
6	MS DATA

## 2.12 ATX/AT Mode Selection (PSON1)

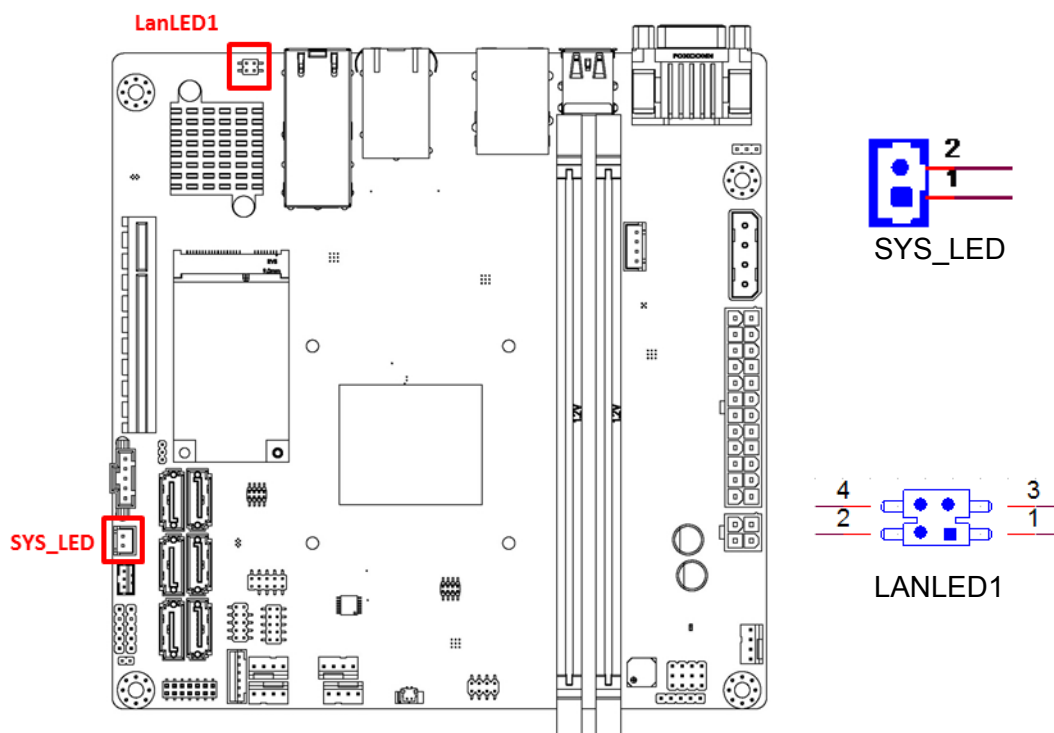


**Table 2.24: PSON1**

Function	Jumper Setting
AT Mode (1-2)	 3 2 1
ATX Mode (2-3) (Default)	 3 2 1



## 2.13 System Error LED Connector (SYS\_LED) / NETWORK LED Pin Header (LANLED1)



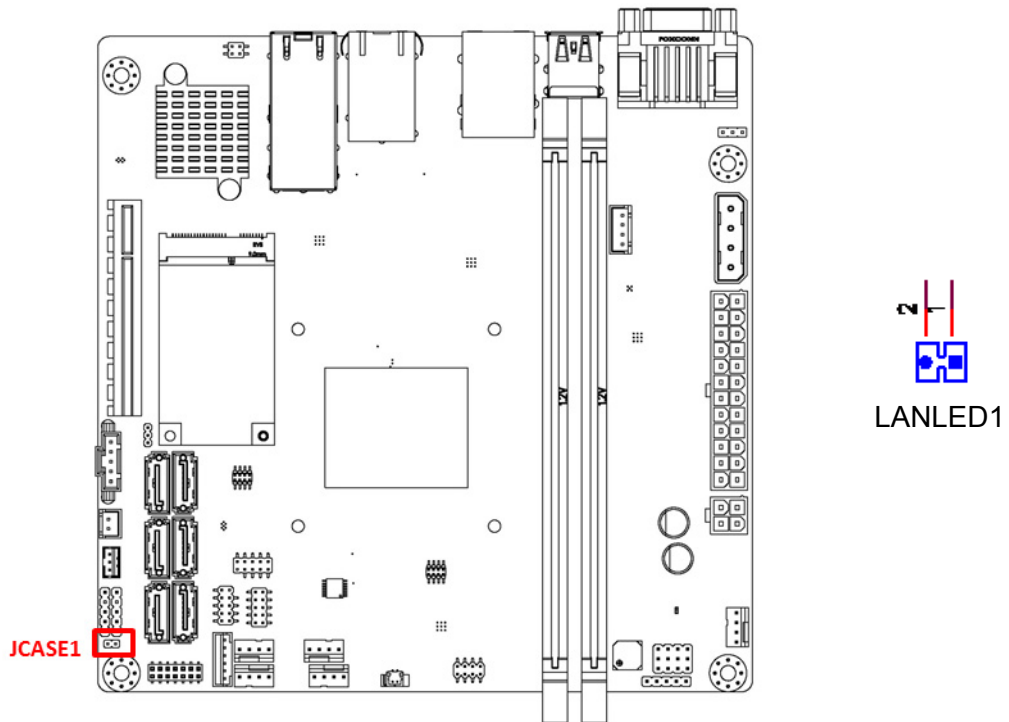
**Table 2.25: SYS\_LED**

Pin	Signal	Pin	Signal
1	+3.3V_Stand by	2	ERR_LED#

**Table 2.26: LANLED1**

Pin	Signal	Pin	Signal
1	LAN1 ACT# LED	2	+3.3V Stand by
3	LAN2 ACT# LED	4	+3.3V Stand by

## 2.14 Case-Open Detect Connector (JCASE1)



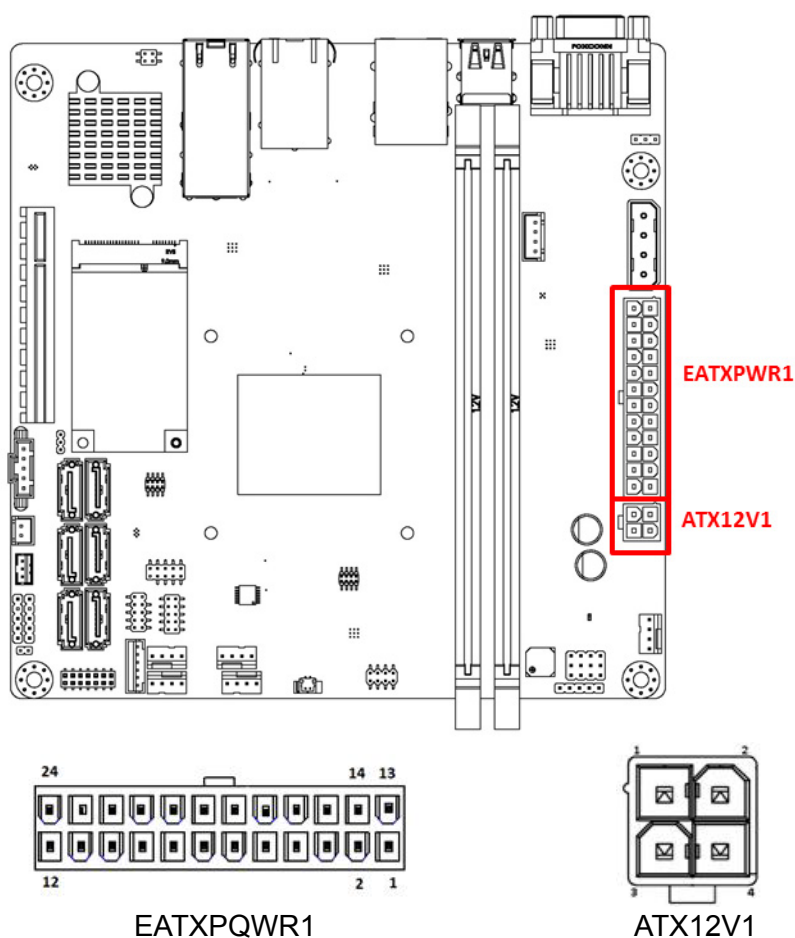
**Table 2.27: JCASE1**

Pin	Signal
1	CASEOP#
2	GND

## 2.15 Power Connector (EATXPWR1, ATX12V1)

This connector is for an ATX power supply with EATXPWR1 or DC-12V only with ATX12V1. The plugs from the power supply are designed to fit these connectors in only one direction. Determine the proper orientation and push down firmly until the connectors mate completely.

- Note!**
1. Please use either EATXPWR1 or ATX12V1. Do not use both connectors at the same time.
  2. Please connect the ATX12V1 connector with the PSU ATX 12V 4-pin connector.
  3. For a fully configured system, we recommend that you use a power supply unit (PSU) that complies with ATX 12 V Specification 2.0 (or later version).



**Table 2.28: EATXPWR1**

Pin	Signal	Pin	Signal
1	+3.3V	13	+3.3V
2	+3.3V	14	-12V
3	GND	15	GND
4	+5V	16	PSON#
5	GND	17	GND
6	+5V	18	GND
7	GND	19	GND

**Table 2.28: EATXPWR1**

8	POWER_OK	20	NC
9	+5VSB	21	+5V
10	+12V	22	+5V
11	+12V	23	+5V
12	+3.3V	24	GND

**Table 2.29: ATX12V1**

Pin	Signal	Pin	Signal
1	GND	2	GND
3	+12V	4	+12V

## 2.16 PCI Express x8 Slot (PCIEX8\_1)

AIMB-290 provides a PCIe x8 slot to install add-on cards when their applications require higher graphic performance than the CPU embedded graphics controller can be provided.

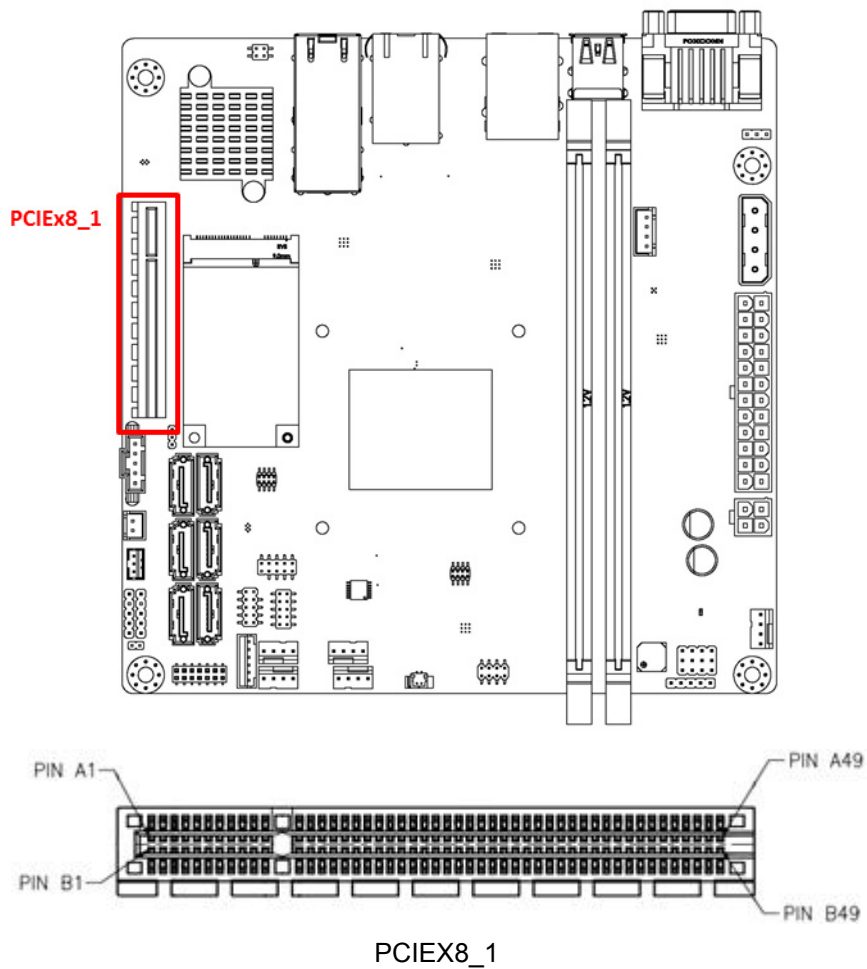


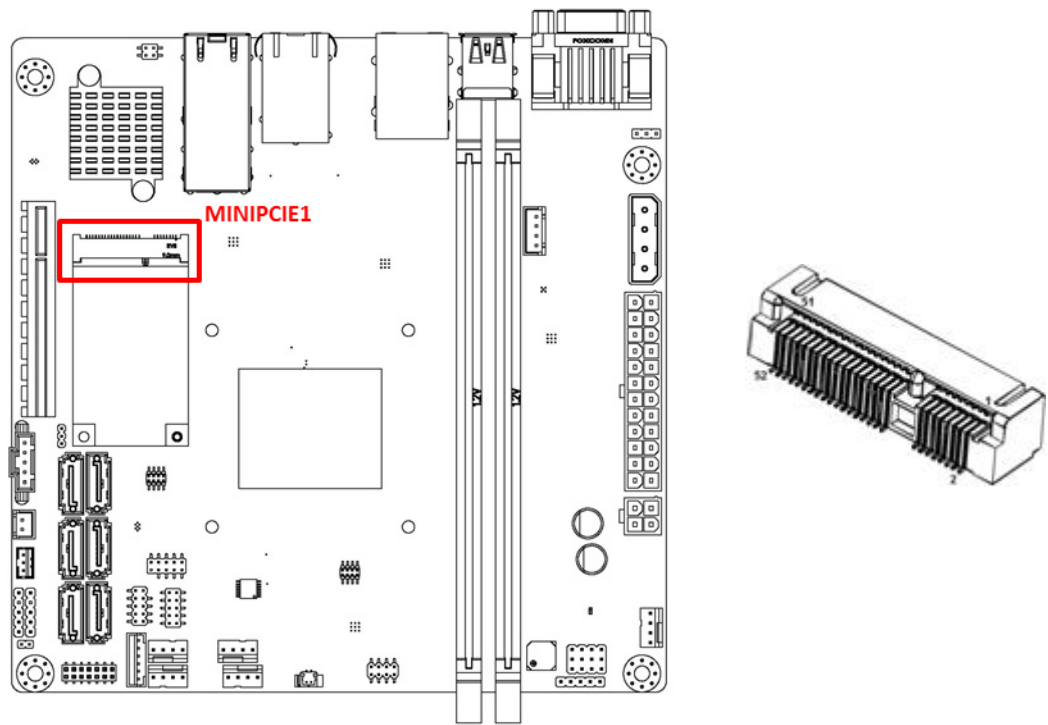
Table 2.30: PCIEX8\_1

Pin	Signal	Pin	Signal
B1	+12V	A1	N.C.
B2	+12V	A2	+12V
B3	+12V	A3	+12V
B4	GND	A4	GND
B5	SMB_CLK	A5	N.C.
B6	SMB_DATA	A6	N.C.
B7	GND	A7	N.C.
B8	+3.3V	A8	N.C.
B9	N.C.	A9	+3.3V
B10	+3.3VAUX	A10	+3.3V
B11	WAKE#	A11	PWRGD
B12	N.C.	A12	GND
B13	GND	A13	REFCLK+
B14	TX7+	A14	REFCLK-
B15	TX7-	A15	GND
B16	GND	A16	RX7+
B17	N.C.	A17	RX7-
B18	GND	A18	GND
B19	TX6+	A19	N.C.
B20	TX6-	A20	GND
B21	GND	A21	RX6+
B22	GND	A22	RX6-
B23	TX5+	A23	GND
B24	TX5-	A24	GND
B25	GND	A25	RX5+
B26	GND	A26	RX5-
B27	TX4+	A27	GND
B28	TX4-	A28	GND
B29	GND	A29	RX4+
B30	N.C.	A30	RX4-
B31	N.C.	A31	GND
B32	GND	A32	N.C.
B33	TX3+	A33	N.C.
B34	TX3-	A34	GND
B35	GND	A35	RX3+
B36	GND	A36	RX3-
B37	TX2+	A37	GND
B38	TX2-	A38	GND
B39	GND	A39	RX2+
B40	GND	A40	RX2-
B41	TX1+	A41	GND
B42	TX1-	A42	GND
B43	GND	A43	RX1+
B44	GND	A44	RX1-
B45	TX0+	A45	GND

**Table 2.30: PCIEX8\_1**

B46	TX0-	A46	GND
B47	GND	A47	RX0+
B48	N.C.	A48	RX0-
B49	GND	A49	GND

## 2.17 MINIPCIIE / mSATA Connector (MINIPCIIE1)

**Table 2.31: MINIPCIIE1**

Pin	Signal	Pin	Signal
1	WAKE#	2	+3.3Vaux
3	Reserved	4	GND
5	Reserved	6	+1.5V
7	CLKREQ#	8	Reserved
9	GND	10	Reserved
11	REFCLK-	12	Reserved
13	REFCLK+	14	Reserved
15	GND	16	Reserved
17	Reserved	18	GND
19	Reserved	20	DISABLE#
21	DETECT#	22	RESET#
23	PCIE_RX+	24	+3.3Vaux
25	PCIE_RX-	26	GND
27	GND	28	+1.5V
29	GND	30	SMB_CLK
31	PCIE_TX-	32	SMB_DATA

**Table 2.31: MINIPCIE1**

33	PCIE_TX+	34	GND
35	GND	36	USB_D-
37	GND	38	USB_D+
39	+3.3Vaux	40	GND
41	+3.3Vaux	42	Reserved
43	V1.2_DETECT#	44	LED_WLAN#
45	Reserved	46	Reserved
47	Reserved	48	+1.5V
49	Reserved	50	GND
51	MSATA_DETECT#	52	+3.3Vaux





# Chapter 3

BIOS Operation

## 3.1 Introduction

With the AMI BIOS Setup program, you can modify BIOS settings to control the special features of your computer. The Setup program uses a number of menus for making changes. This chapter describes the basic navigation of the AIMB-290 setup screens.

## 3.2 BIOS Setup

The AIMB-290 Series system has AMI BIOS built in, with a SETUP utility that allows users to configure required settings or to activate certain system features.

The SETUP saves the configuration in the FLASH of the motherboard. When the power is turned off, the battery on the board supplies the necessary power to preserve the FLASH.

When the power is turned on, press the <Del> or <Esc> button during the BIOS POST (Power-On Self Test) to access the CMOS SETUP screen.

---

### Control Keys

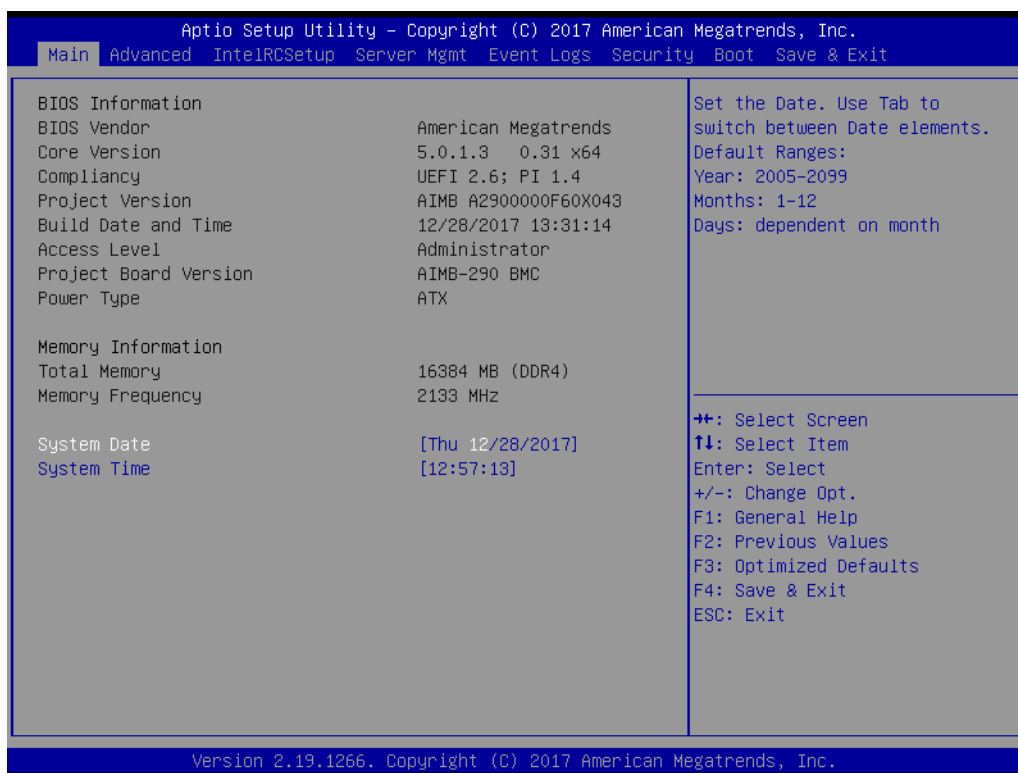
---

< ← >< → >	Select Screen
< ↑ >< ↓ >	Select Item
<Enter>	Select
<+/->	Change Opt
<F1>	General help
<F2>	Previous Values
<F3>	Optimized Defaults
<F4>	Save & Exit
<Esc>	Exit

---

### 3.2.1 Main Menu

Press <Del> to enter AMI BIOS CMOS Setup Utility, the Main Menu will appear on the screen. Use arrow keys to select among the items and press <Enter> to accept or enter the sub-menu.



The Main BIOS setup screen has two main frames. The left frame displays all the options that can be configured. Grayed-out options cannot be configured; options in blue can. The right frame displays the key legend.

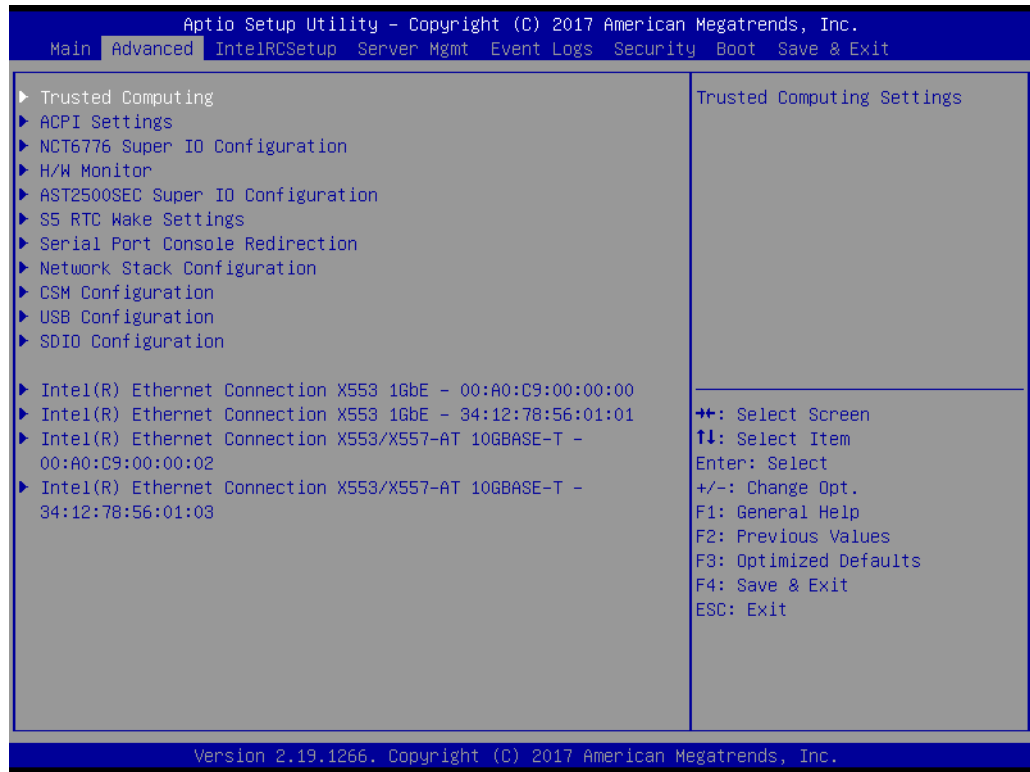
Above the key legend is an area reserved for a text message. When an option is selected in the left frame, it is highlighted in white. Often a text message will accompany it.

#### ■ System time / System date

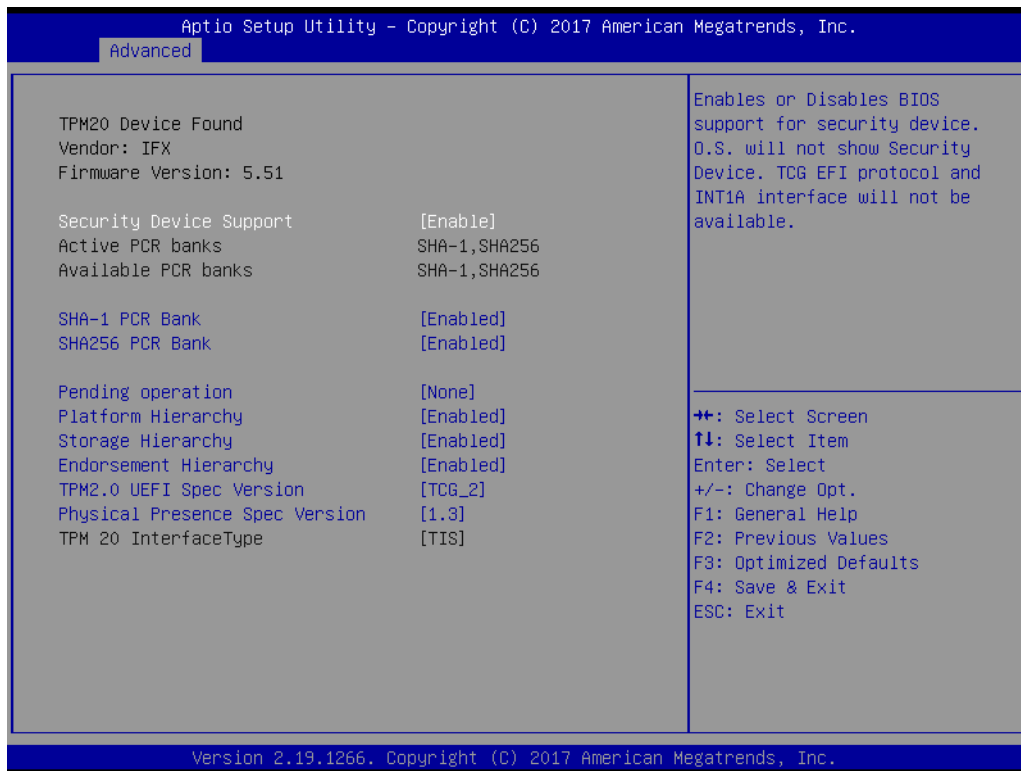
Use this option to change the system time and date. Highlight System Time or System Date using the <Arrow> keys. Enter new values through the keyboard. Press the <Tab> key or the <Arrow> keys to move between fields. The date must be entered in MM/DD/YY format. The time must be entered in HH:MM:SS format.

### 3.2.2 Advanced BIOS Features

Select the Advanced tab from the AIMB-290 setup screen to enter the Advanced BIOS Setup screen. You can select any of the items in the left frame of the screen, You can display an Advanced BIOS Setup option by highlighting it using the <Arrow> keys. All Advanced BIOS Setup options are described in this section. The Advanced BIOS Setup screen is shown below. The sub menus are described on the following pages.

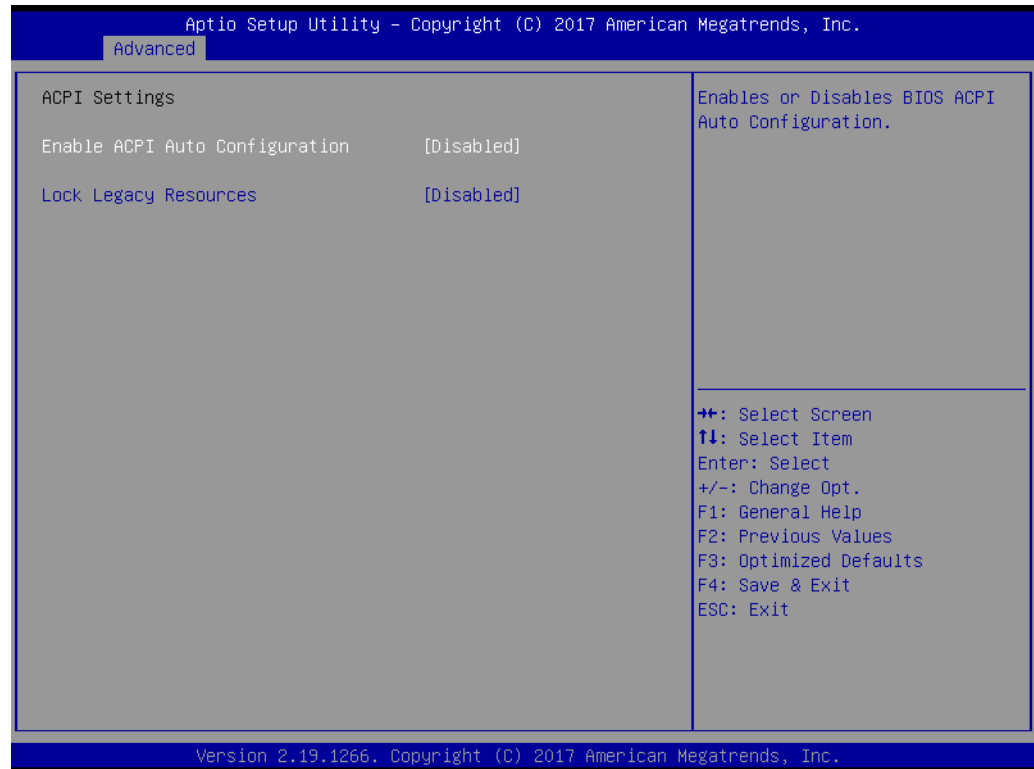


### 3.2.2.1 Trusted Computing



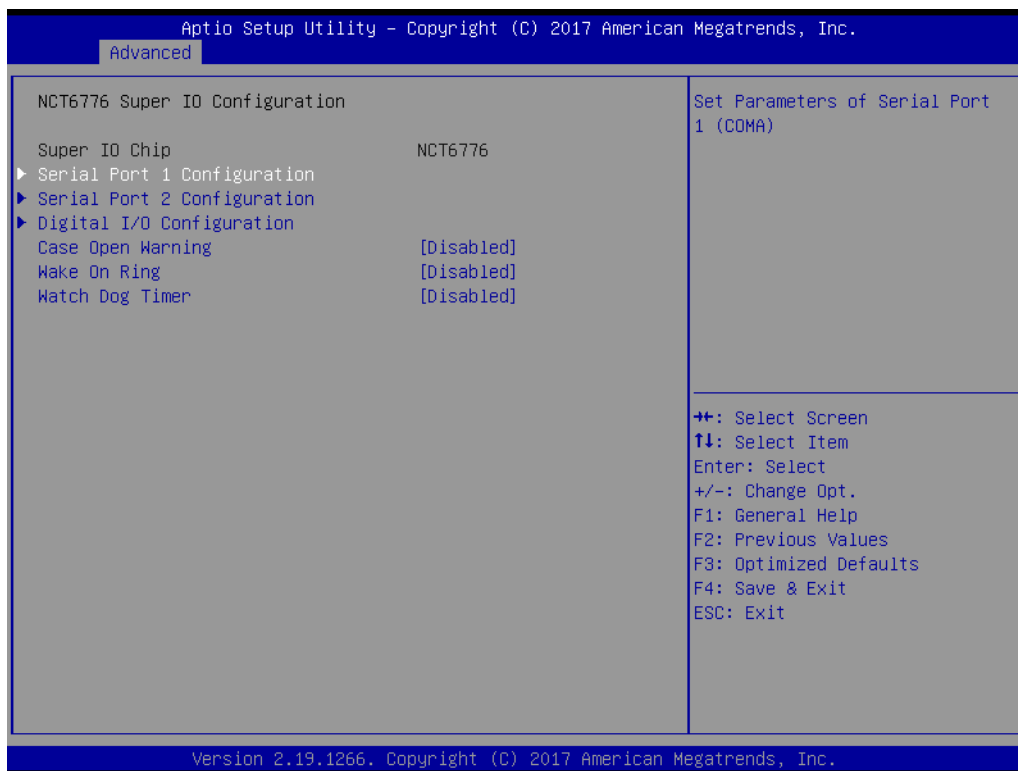
- **Security Device Support**  
Enable or Disable BIOS support for security device.
- **TPM State**  
Enable or disable security device.
- **Pending operation**  
Schedule an operation for the security device.
- **Device Select**  
TPM 1.2 will restrict support to TPM 1.2 devices, TPM 2.0 will restrict support to TPM 2.0 devices, Auto will support both with the default set to TPM 2.0 devices if not found, TPM 1.2 devices will be enumerated.

### 3.2.2.2 ACPI Settings

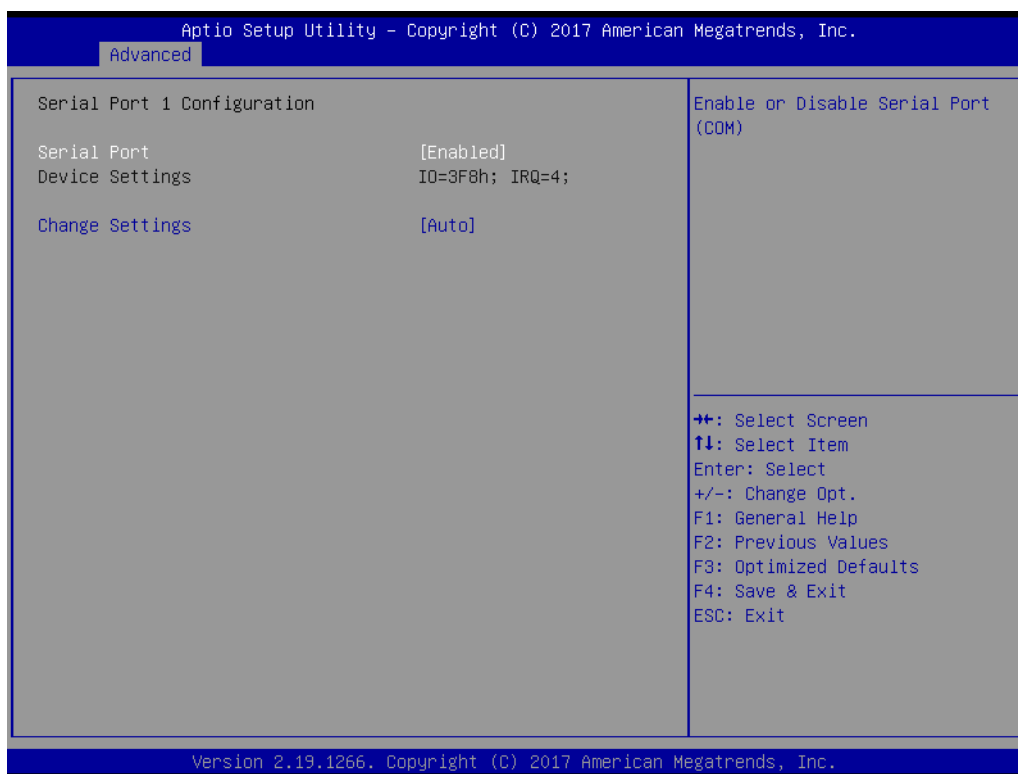


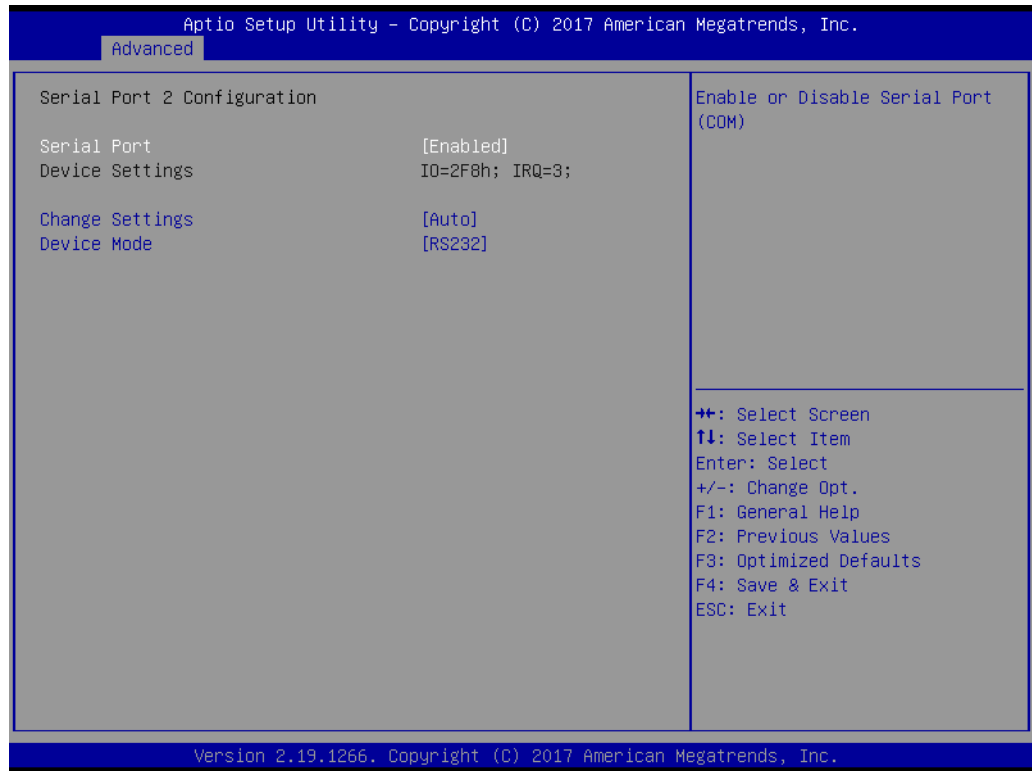
- **Enable ACPI Auto Configuration**  
Enable or Disable ACPI Auto Configuration
- **Lock Legacy Resources**  
Enable or disable lock of legacy resources.

### 3.2.2.3 NCT6776 Super IO Configuration



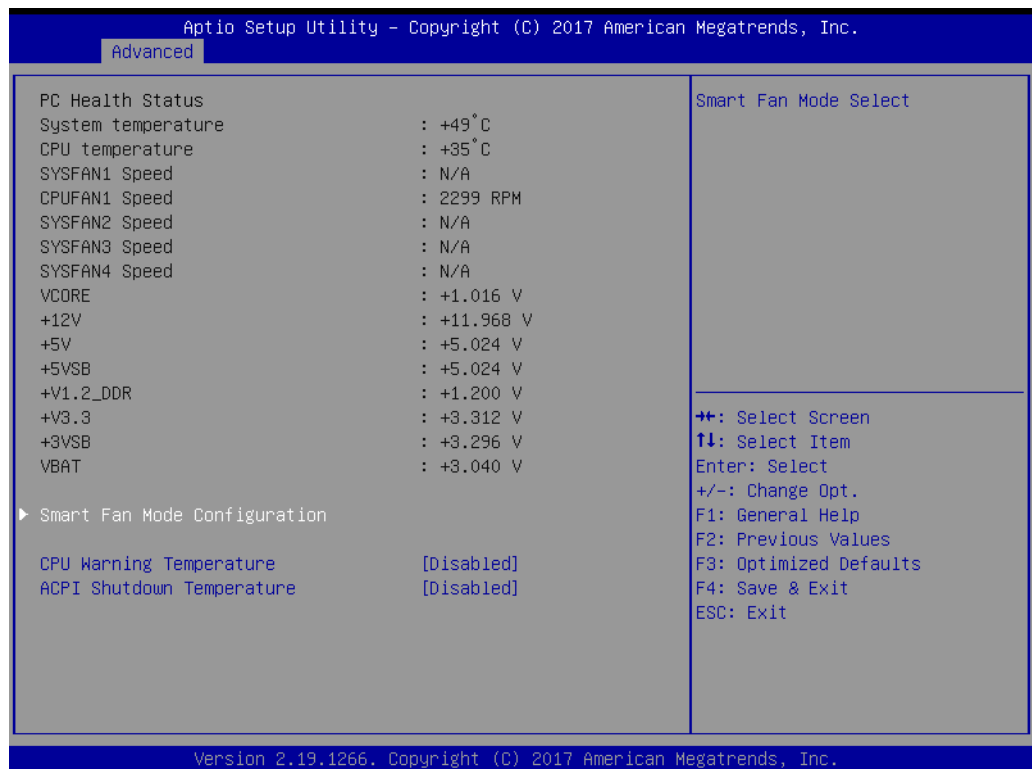
### Serial Port 1 Configuration





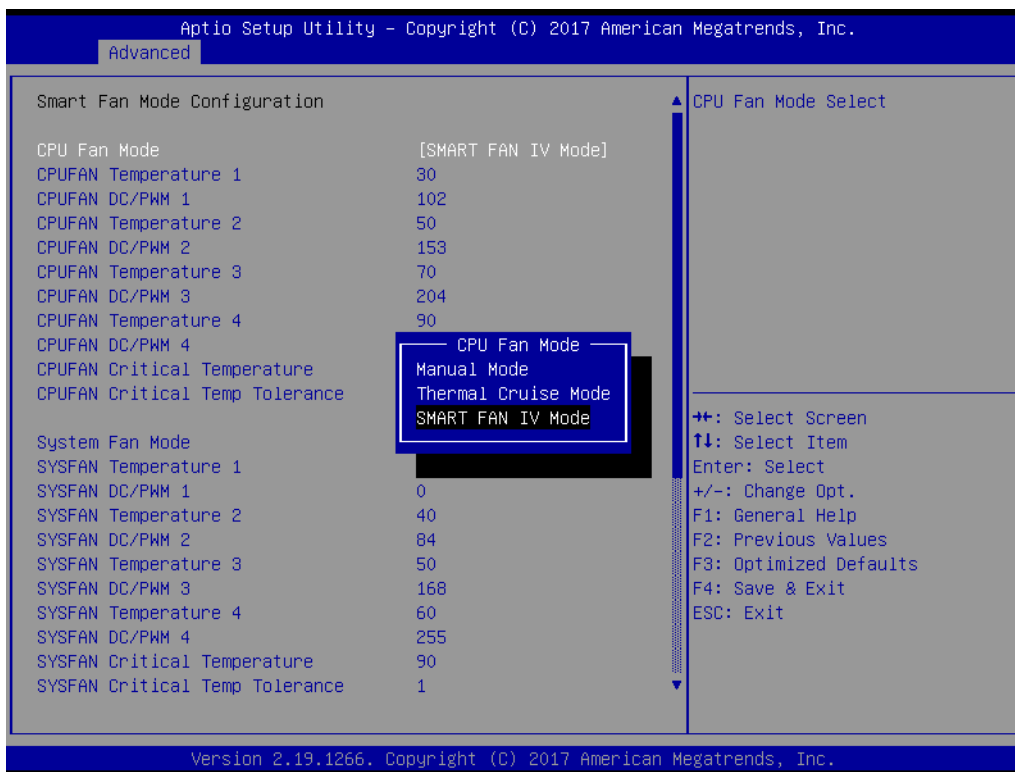
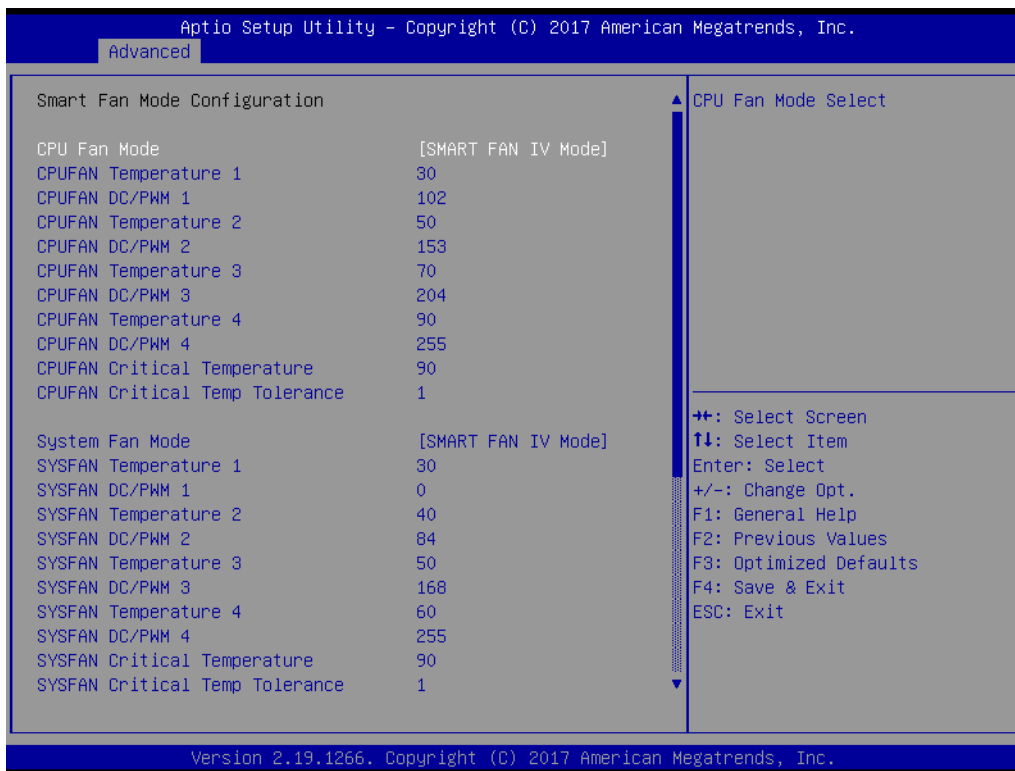
- **Serial Port**  
Enable or disable serial port 1
- **Change Settings**  
Select an optimal settings for super IO device.

### 3.2.2.4 H/W Monitor PC Health Status



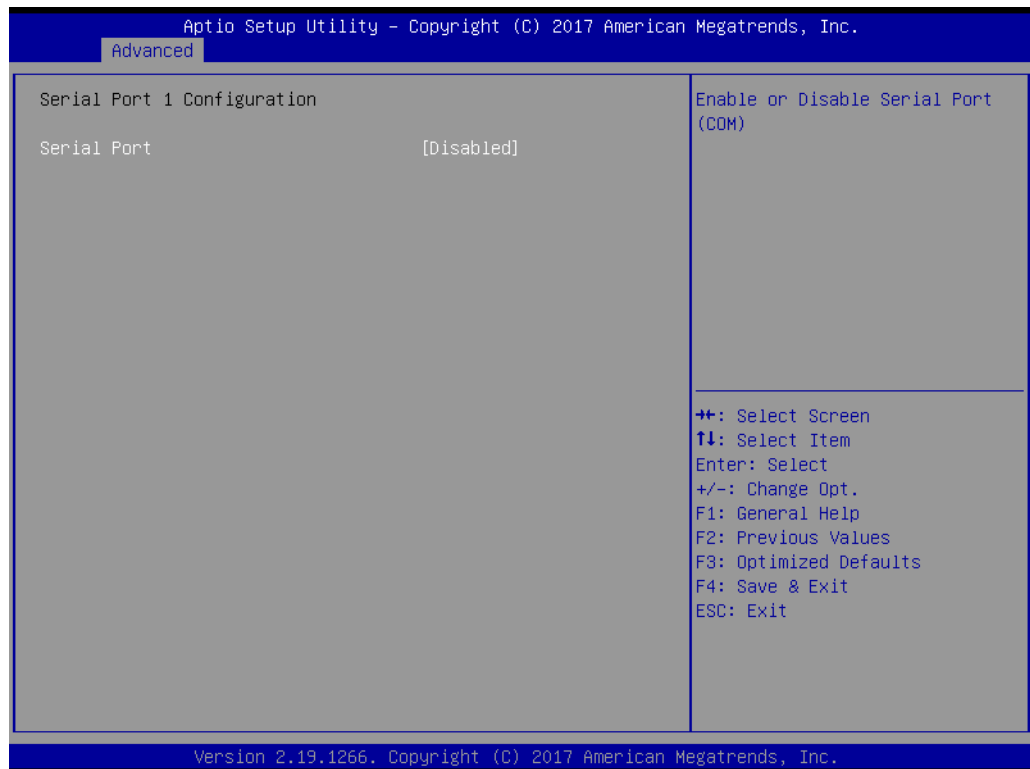


## Smart Fan Mode Configuration

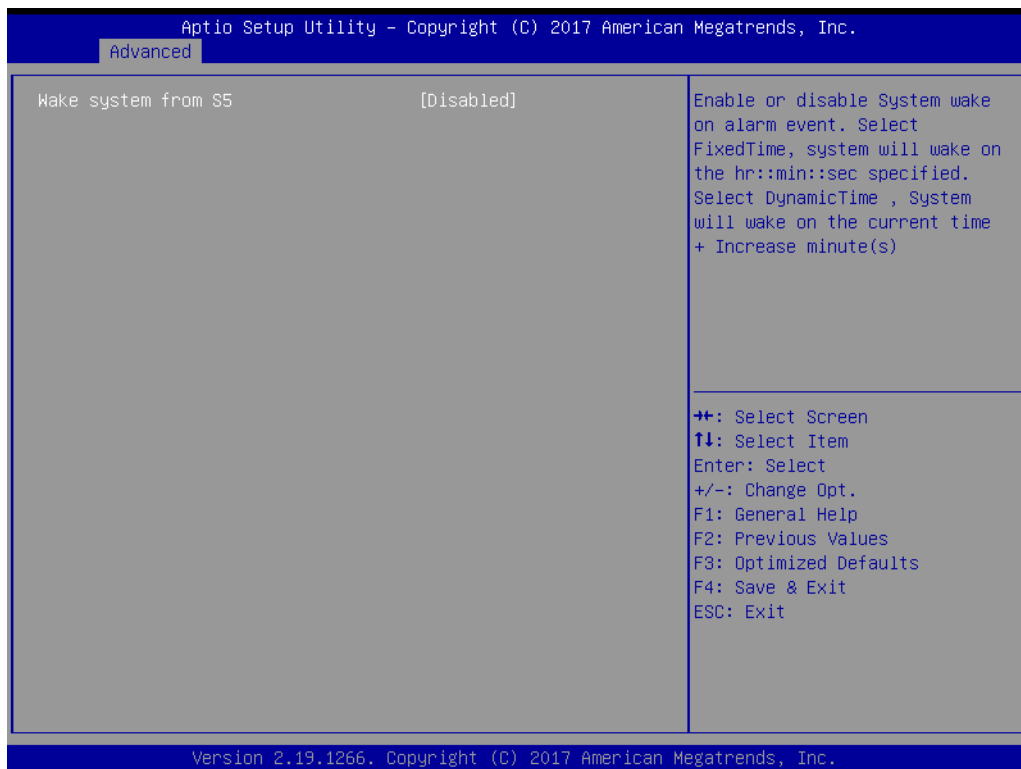


- **CPU Fan Mode / System Fan Mode**  
Select an optimal settings for Fan mode.

### 3.2.2.5 AST2500SEC Super IO Configuration

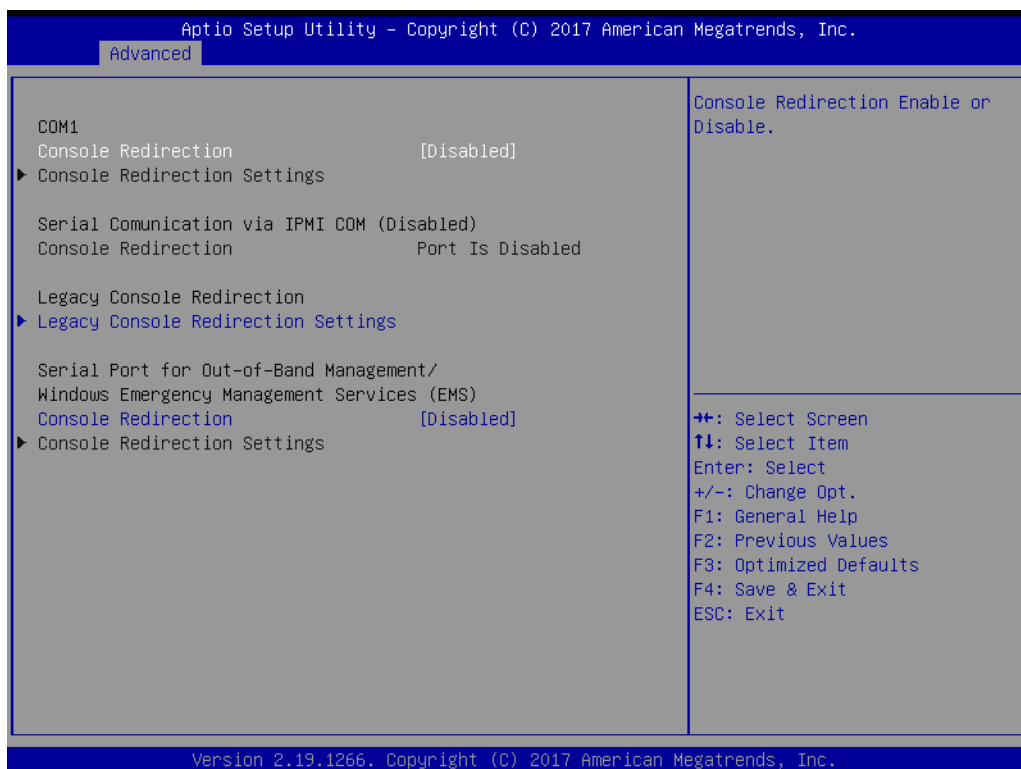


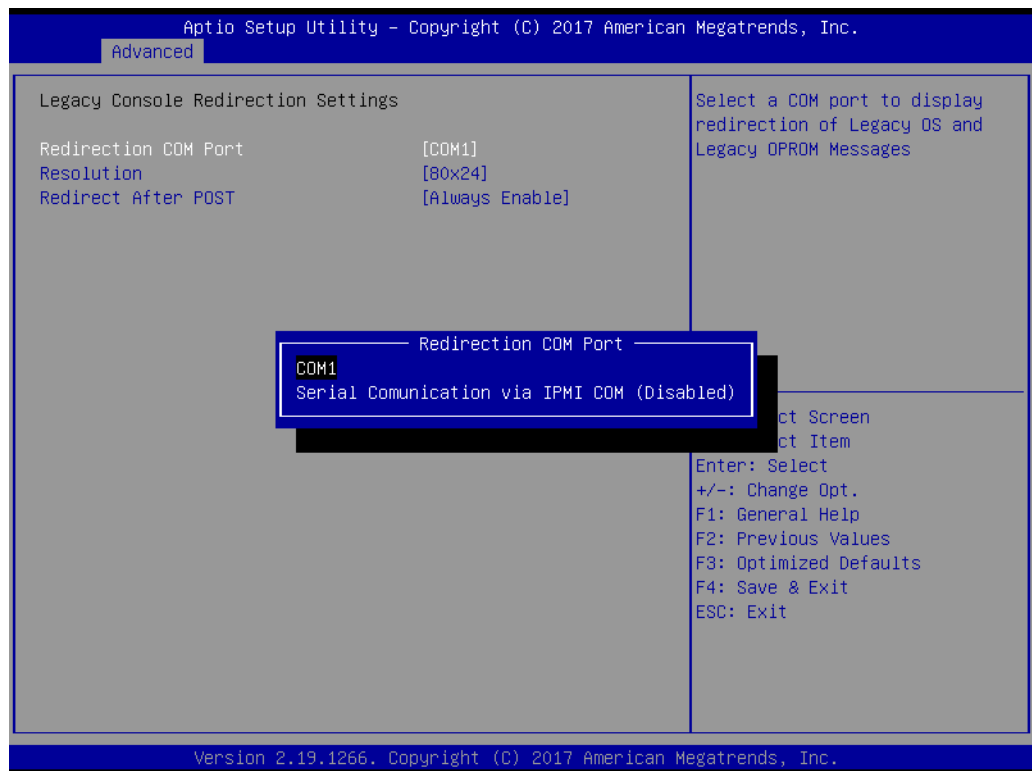
### 3.2.2.6 S5 RTC Wake Settings

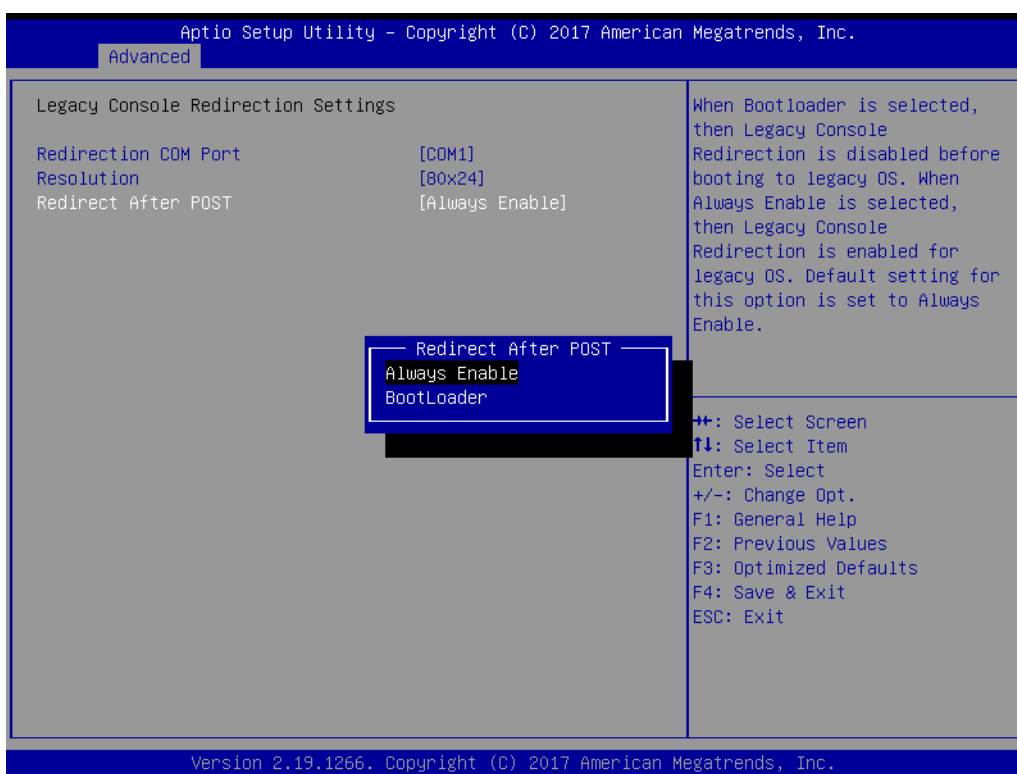
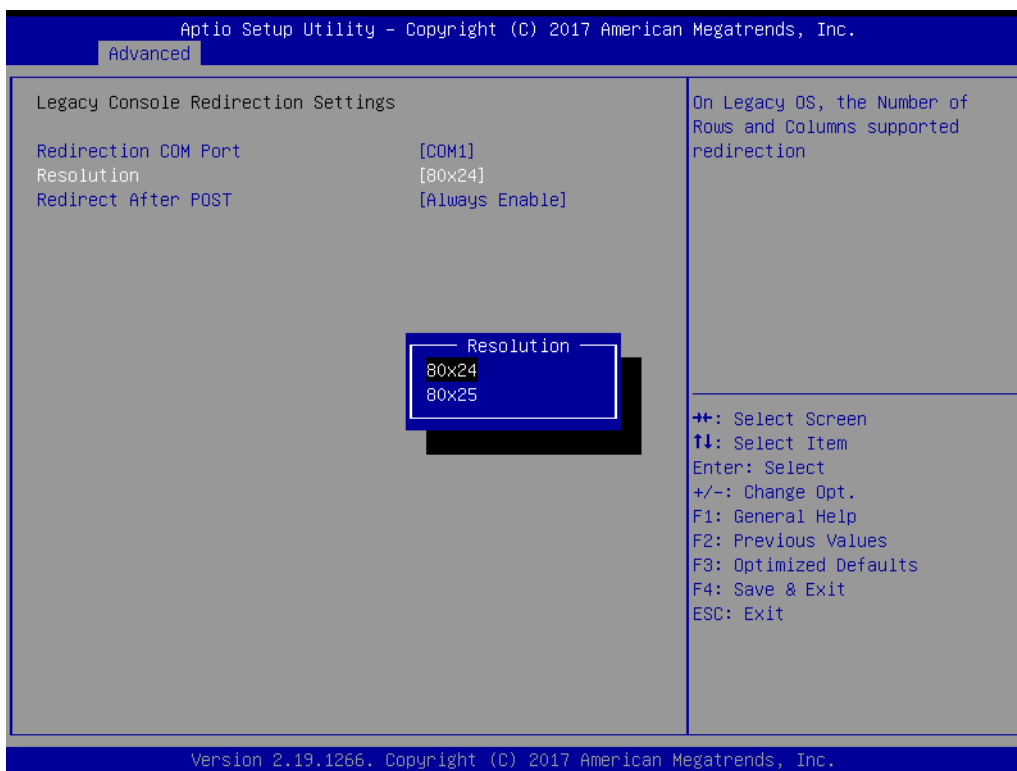


- Wake system from S5**  
 Enable or disable system wake on alarm event. Select FixedTime, system will wake on the hr:min:sec specified. Select DynamicTime, system will wake on the current time + Increase minute(s)

### 3.2.2.7 Serial Port Console Redirection



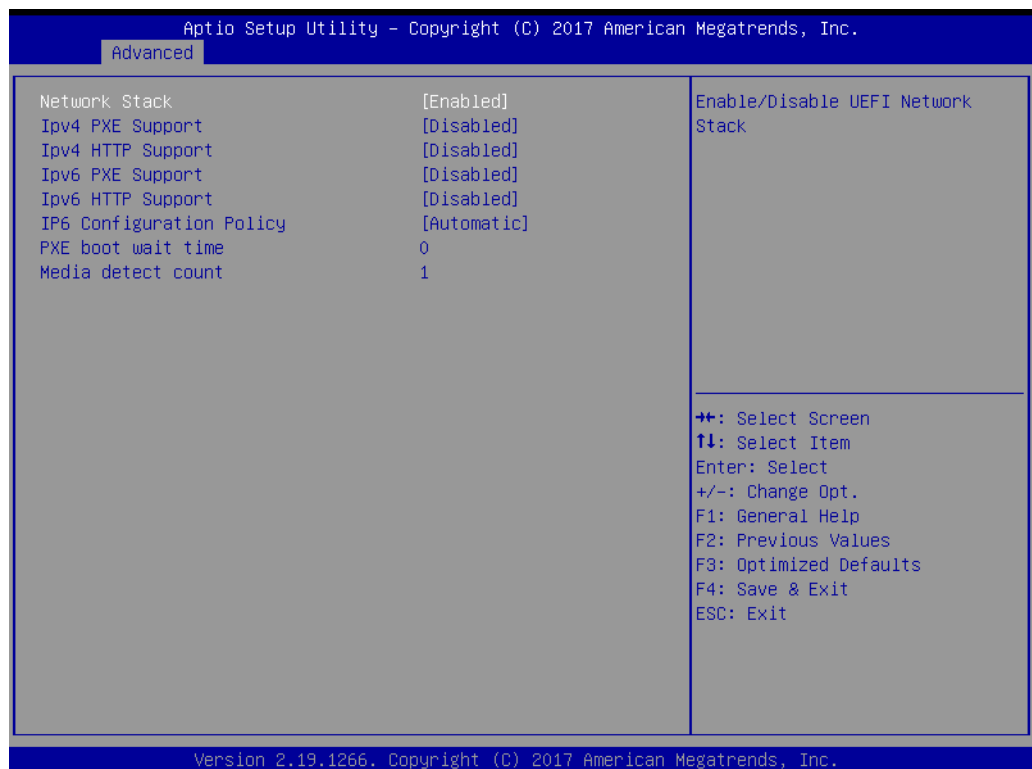




### ■ Console Redirection

This item allows users to enable or disable console redirection.

### 3.2.2.8 Network Stack Configuration



- **Network Stack**  
Enable or Disable UEFI Network Stack

### 3.2.2.9 CSM Configuration

Aptio Setup Utility - Copyright (C) 2017 American Megatrends, Inc.

Advanced

<p>COM1 Console Redirection Settings</p> <p>Terminal Type [ANSI]          Bits per second [115200]          Data Bits [8]          Parity [None]          Stop Bits [1]          Flow Control [None]          VT-UTF8 Combo Key Support [Enabled]          Recorder Mode [Disabled]          Resolution 100x31 [Disabled]          Putty KeyPad [VT100]</p>	<p>Emulation: ANSI: Extended ASCII char set. VT100: ASCII char set. VT100+: Extends VT100 to support color, function keys, etc. VT-UTF8: Uses UTF8 encoding to map Unicode chars onto 1 or more bytes.</p> <hr/> <p>             ++: Select Screen              ↑↓: Select Item              Enter: Select              +/-: Change Opt.              F1: General Help              F2: Previous Values              F3: Optimized Defaults              F4: Save &amp; Exit              ESC: Exit         </p>
---	--

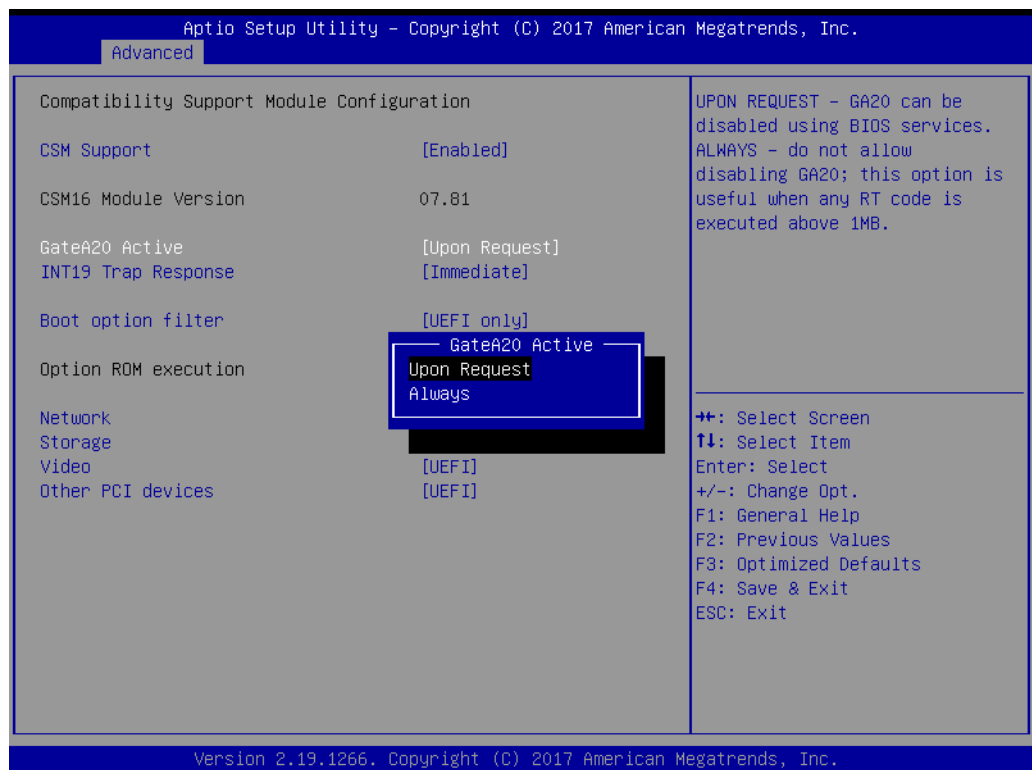
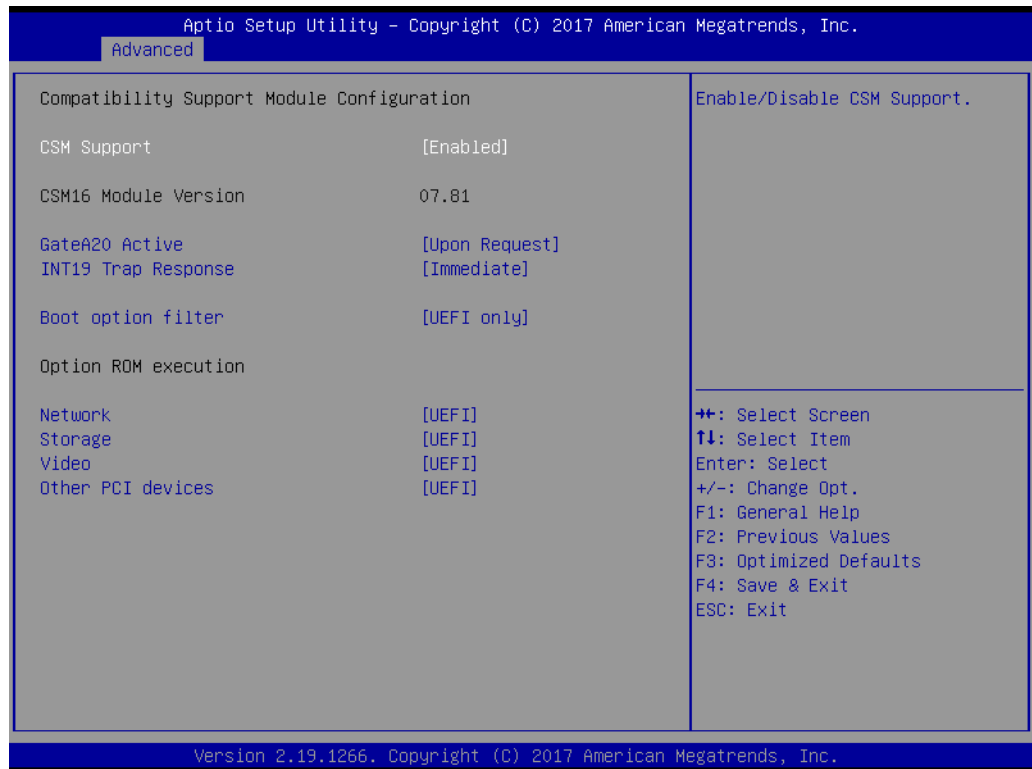
Version 2.19.1266. Copyright (C) 2017 American Megatrends, Inc.

Aptio Setup Utility - Copyright (C) 2017 American Megatrends, Inc.

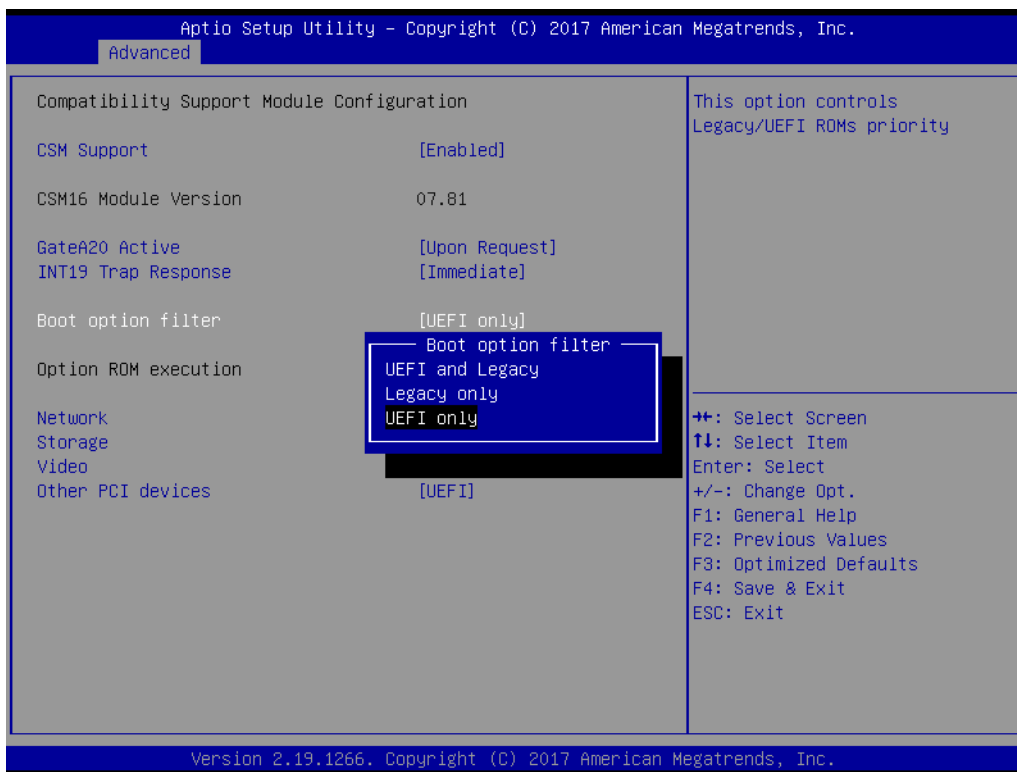
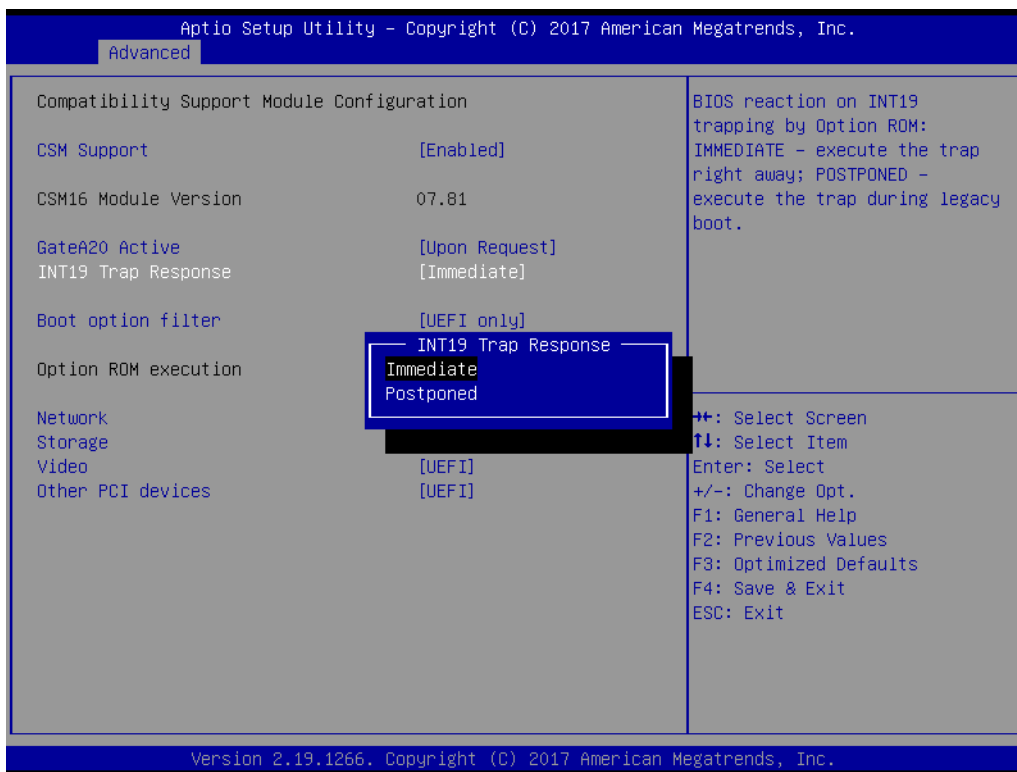
Advanced

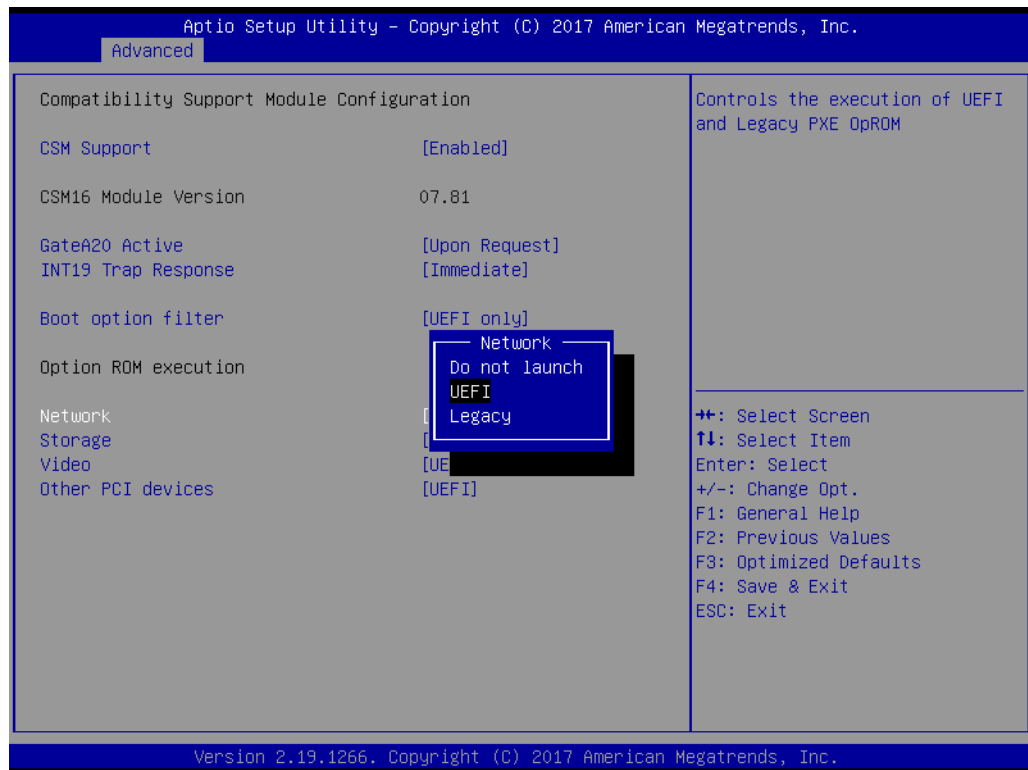
<p>Out-of-Band Mgmt Port [COM1]          Terminal Type [VT-UTF8]          Bits per second [115200]          Flow Control [None]          Data Bits 8          Parity None          Stop Bits 1</p>	<p>Microsoft Windows Emergency Management Services (EMS) allows for remote management of a Windows Server OS through a serial port.</p> <hr/> <p>             ++: Select Screen              ↑↓: Select Item              Enter: Select              +/-: Change Opt.              F1: General Help              F2: Previous Values              F3: Optimized Defaults              F4: Save &amp; Exit              ESC: Exit         </p>
--	---

Version 2.19.1266. Copyright (C) 2017 American Megatrends, Inc.









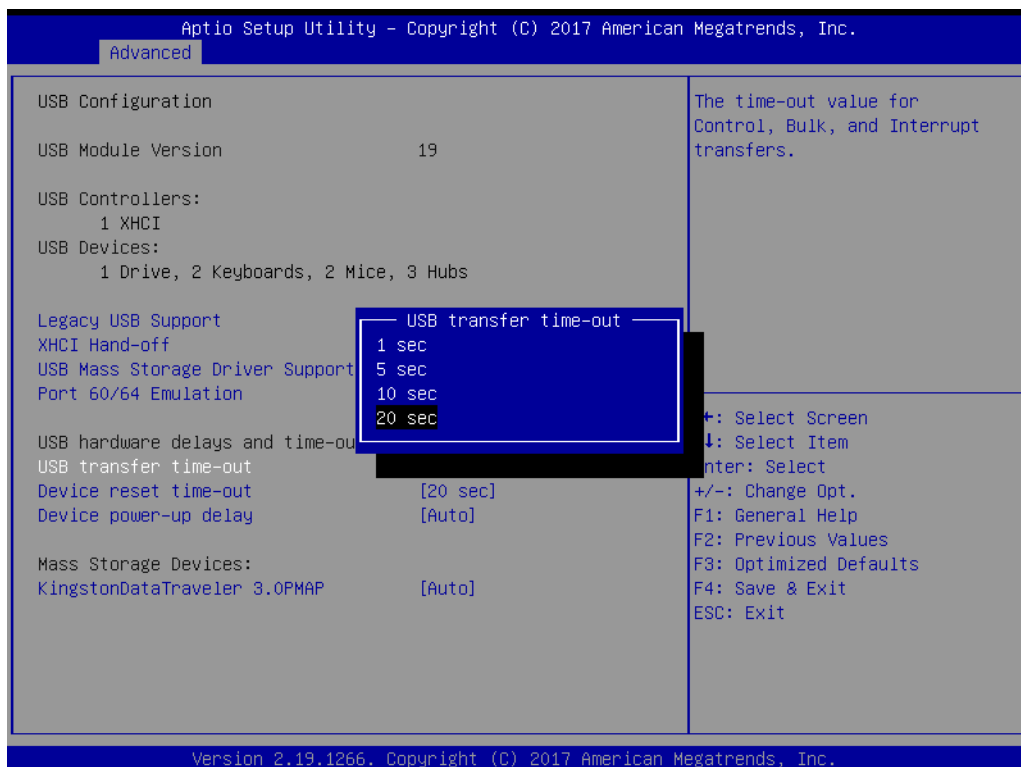
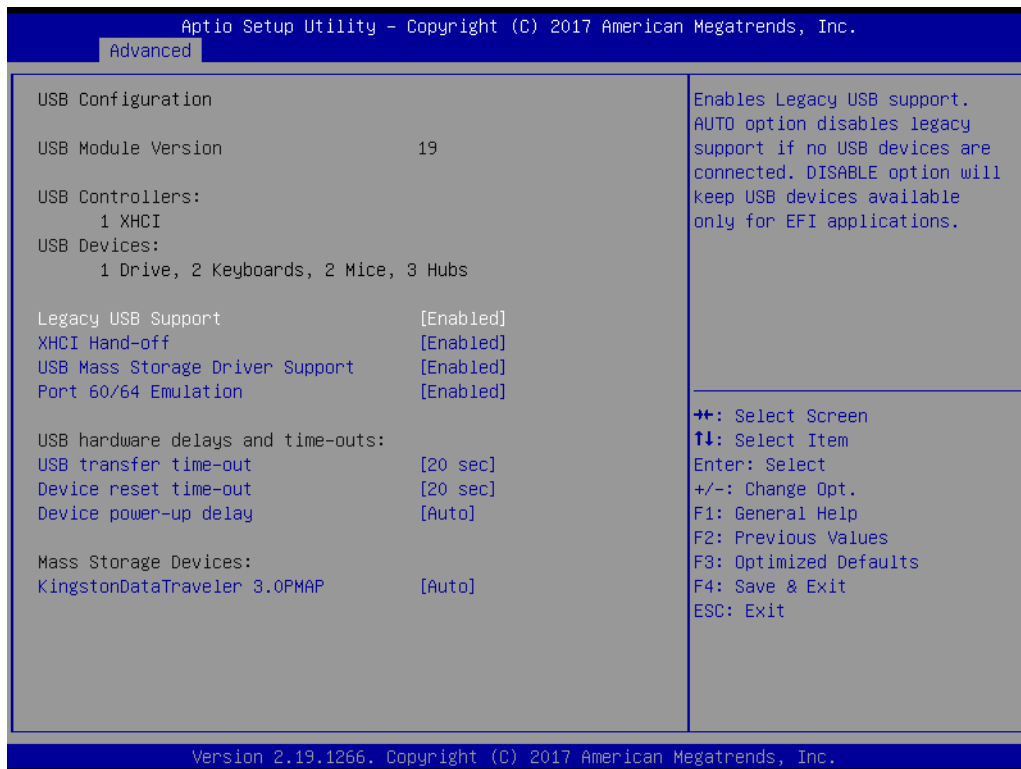
- **CSM Support**  
Enable or disable CSM Support
- **GateA20 Active**  
UPON REQUEST - GA20 can be disabled using BIOS services. ALWAYS - do not allow disabling GA20; this option is useful when any RT code is executed above 1MB.
- **INT19 Trap Response**  
BIOS reaction on INT19 trapping by Option ROM: IMMEDIATE - execute the trap right away; POSTPONED - execute the trap during legacy boot.
- **Boot option filter**  
This option controls Legacy/UEFI ROMs priority.
- **Option ROM execution**
  - Network [ UEFI ]
  - Storage [ UEFI ]
  - Video [ UEFI ]
  - Other PCI device [ UEFI ]

**Note!** *If your HDD or other boot device is installed as Legacy mode, it may cause blue screen situation. There are 2 ways to solve this:*



1. Re-install your OS as UEFI Mode
2. Change all of settings above as " Legacy"
  - Boot option filter ->Legacy Only
  - Network ->Legacy
  - Storage ->Legacy
  - Video ->Legacy
  - Other PCI devices ->Legacy

### 3.2.2.10 USB Configuration

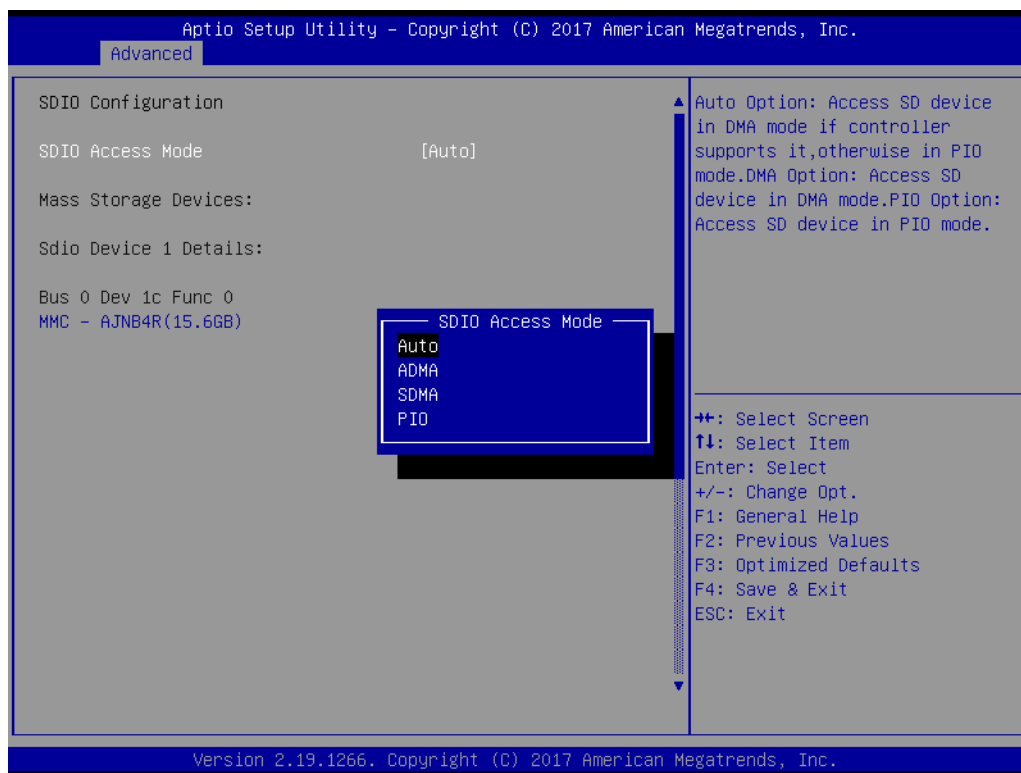


- **Legacy USB Support**  
Enables support for legacy USB. Auto option disables legacy support if no USB devices are connected.
- **XHCI Hand-off**

This is a workaround for OSes without XHCI hand-off support. The XHCI ownership change should be claimed by XHCI driver.

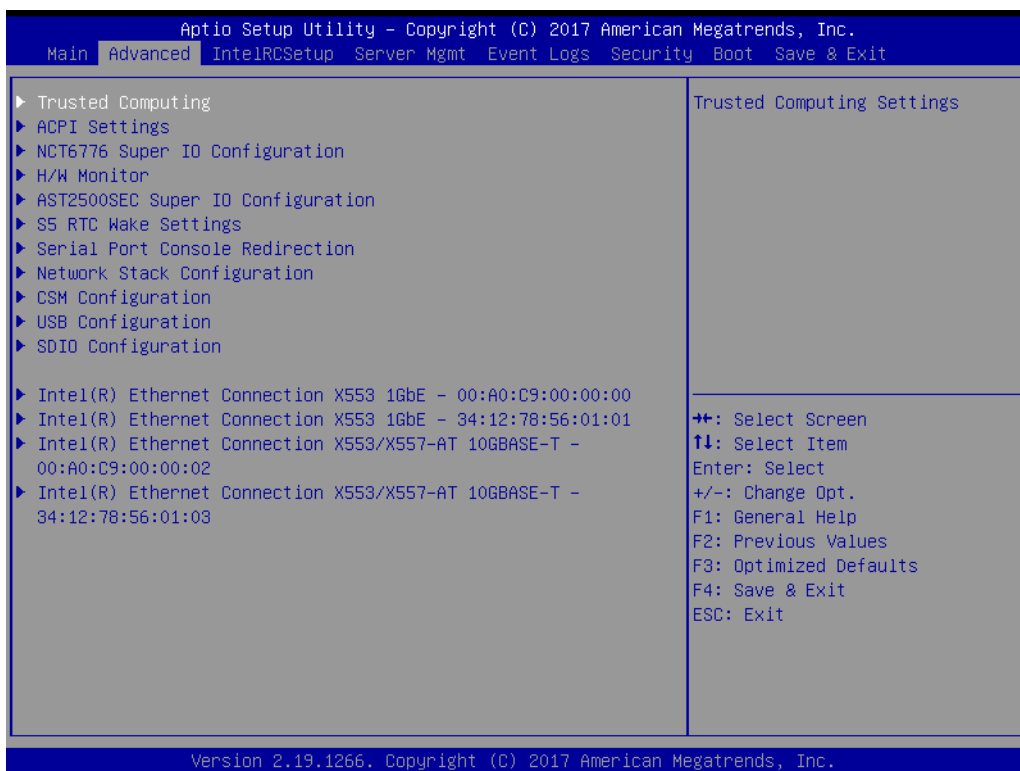
- **USB Mass Storage Driver Support**  
Enable/disable USB Mass Storage Driver support.
- **USB transfer time-out**  
The time-out value for Control, Bulk, and Interrupt transfers.
- **Device reset time-out**  
USB mass storage device start unit command time-out
- **Device power-up delay**  
Maximum time the device will take before it properly reports itself to the host controller. 'Auto' uses default value: for a Root port it is 100ms, for a hub port the delay is taken from Hub descriptor.

### 3.2.2.11 SDIO Configuration





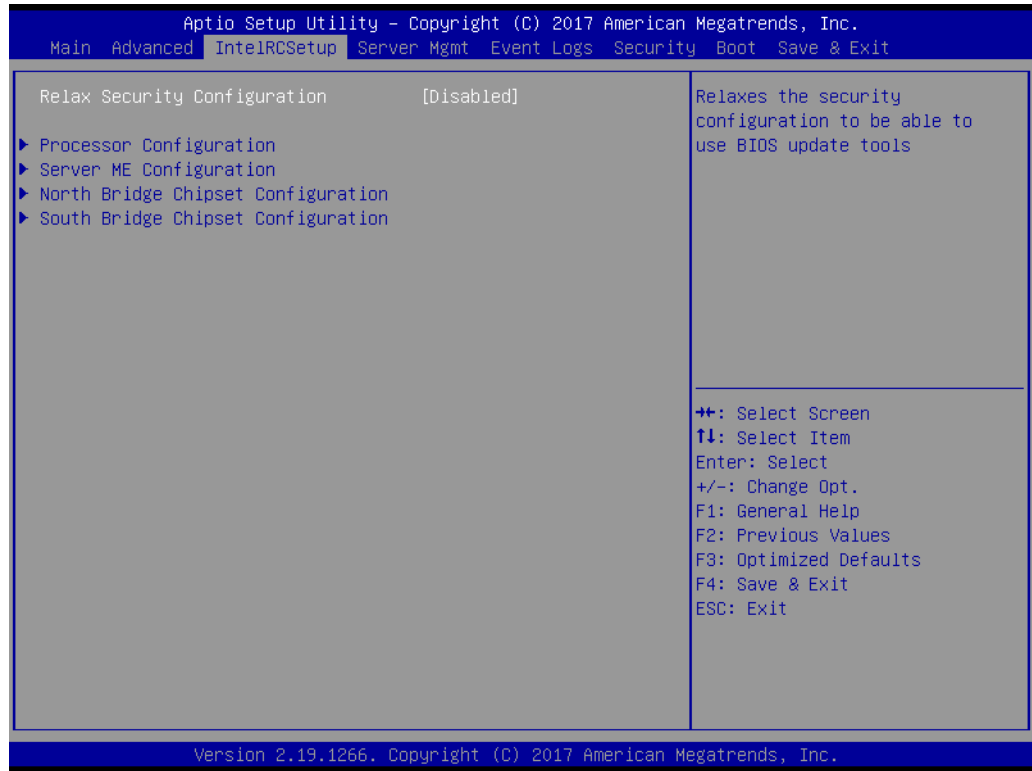
### 3.2.2.12 Intel® Ethernet Connection X553 1GbE



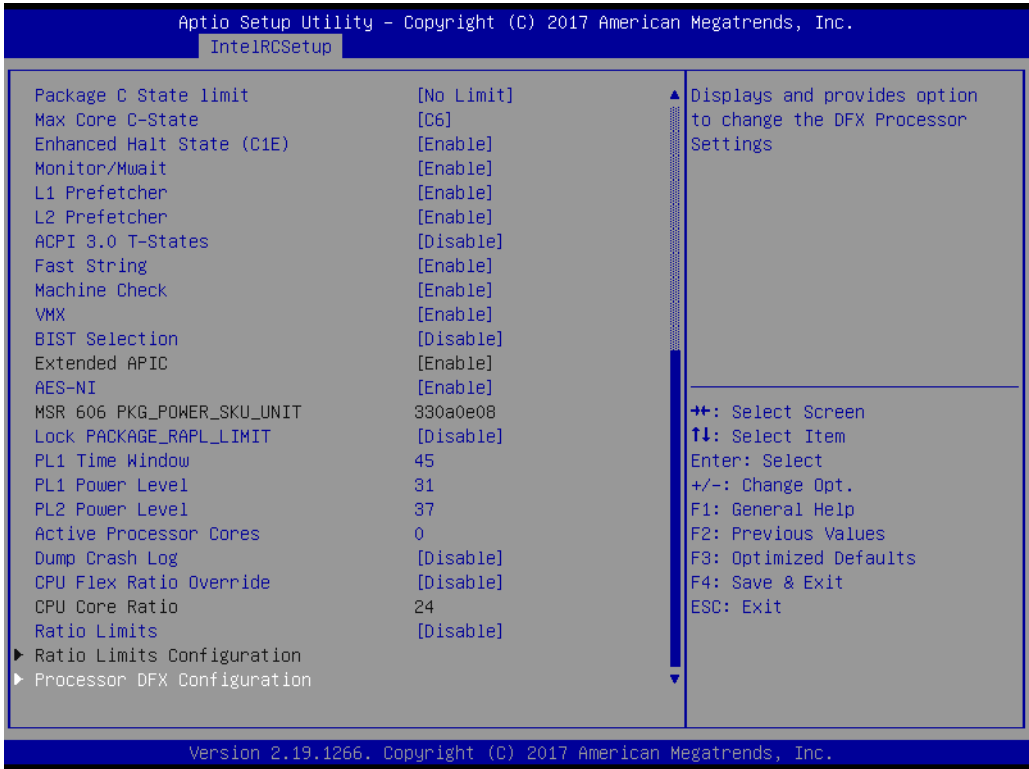
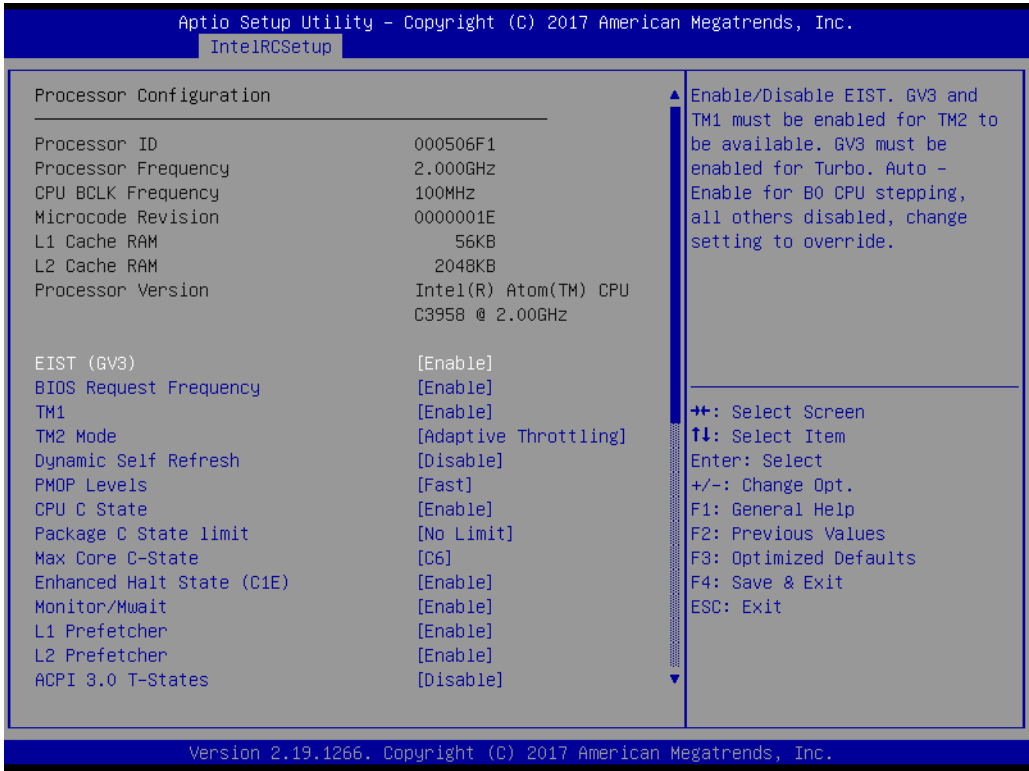
- **NIC Configuration**  
Click to configure the network device port.
- **Link Speed**  
Specifies the port speed used for the selected boot protocol.
- **Wake On LAN**  
Enable or disable Wake On LAN.

### 3.2.3 Chipset Configuration Setting

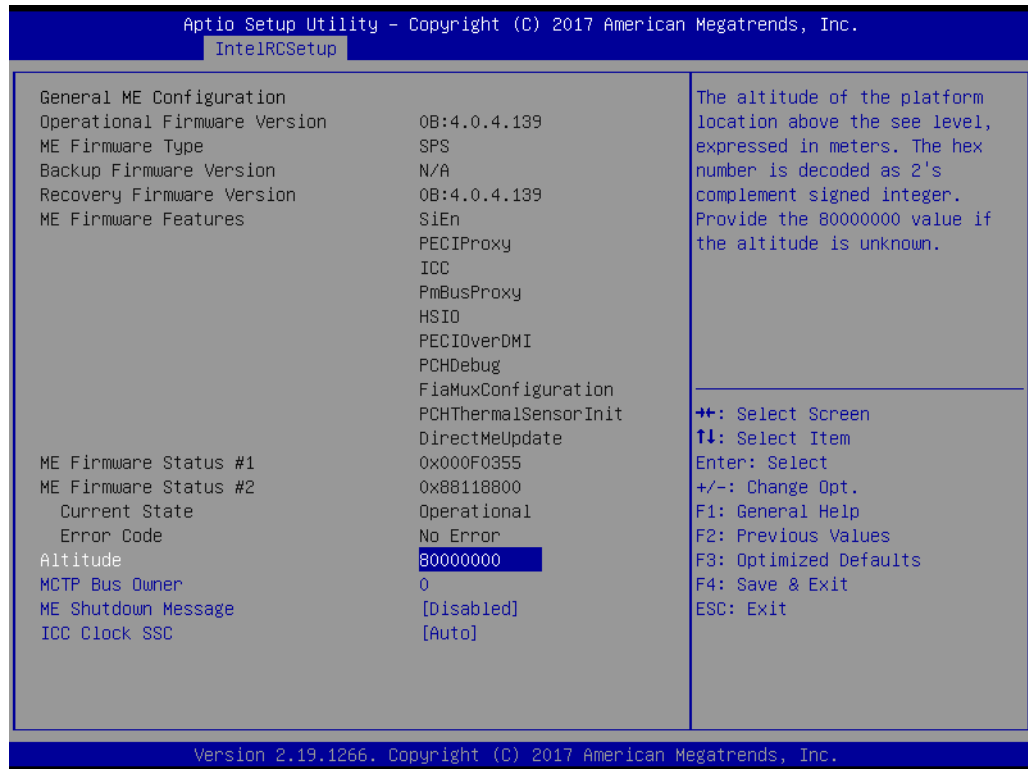
Select the chipset tab from the BIOS setup screen to enter the Chipset Setup screen. Users can select any item in the left frame of the screen, such as PCI express Configuration, to go to the sub menu for that item. Users can display a Chipset Setup option by highlighting it using the <Arrow> keys. All Chipset Setup options are described in this section. The Chipset Setup screens are shown below. The sub menus are described on the following pages.



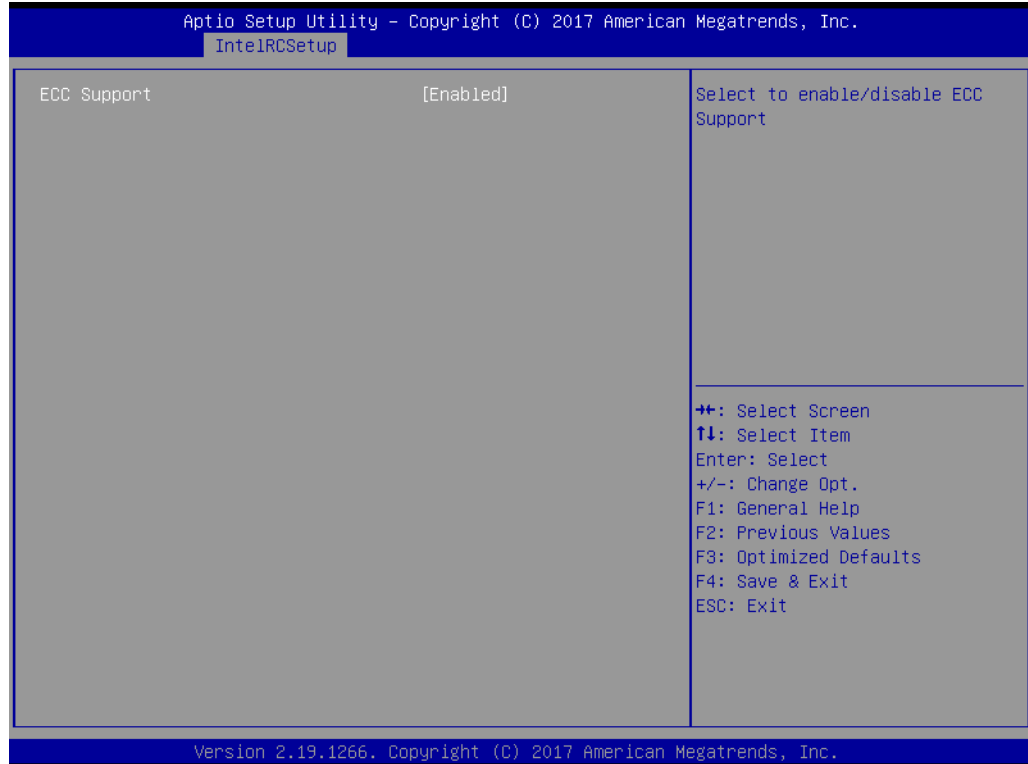
### 3.2.3.1 Processor Configuration



### 3.2.3.2 Server ME Configuration



### 3.2.3.3 North Bridge Chipset Configuration

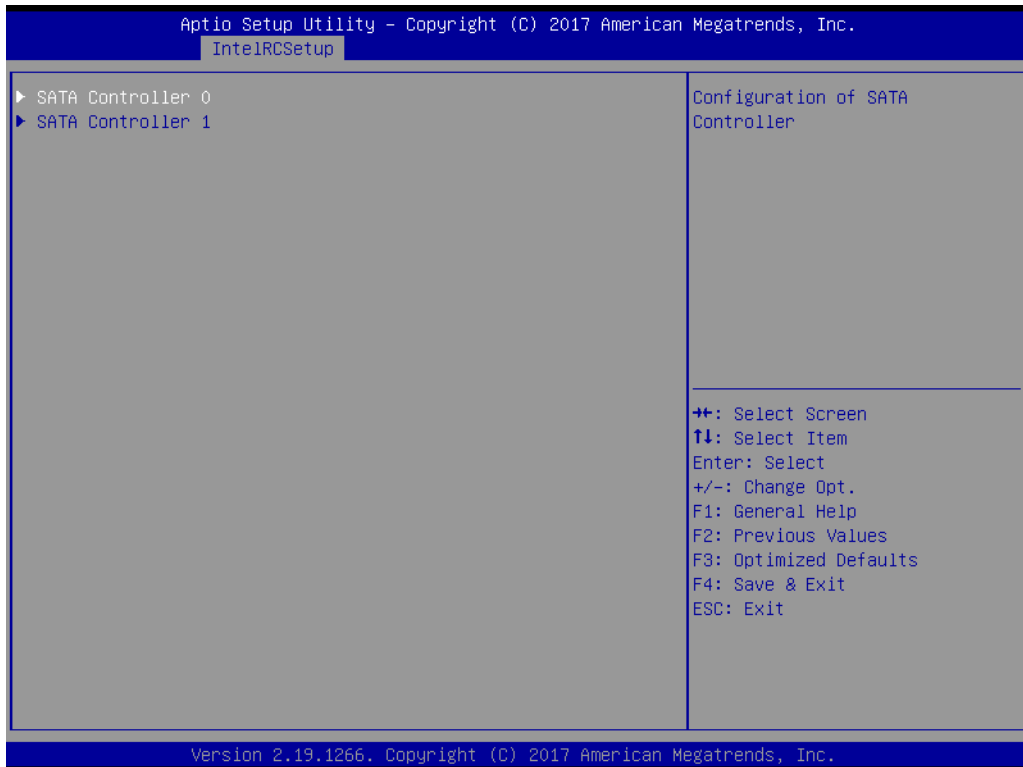
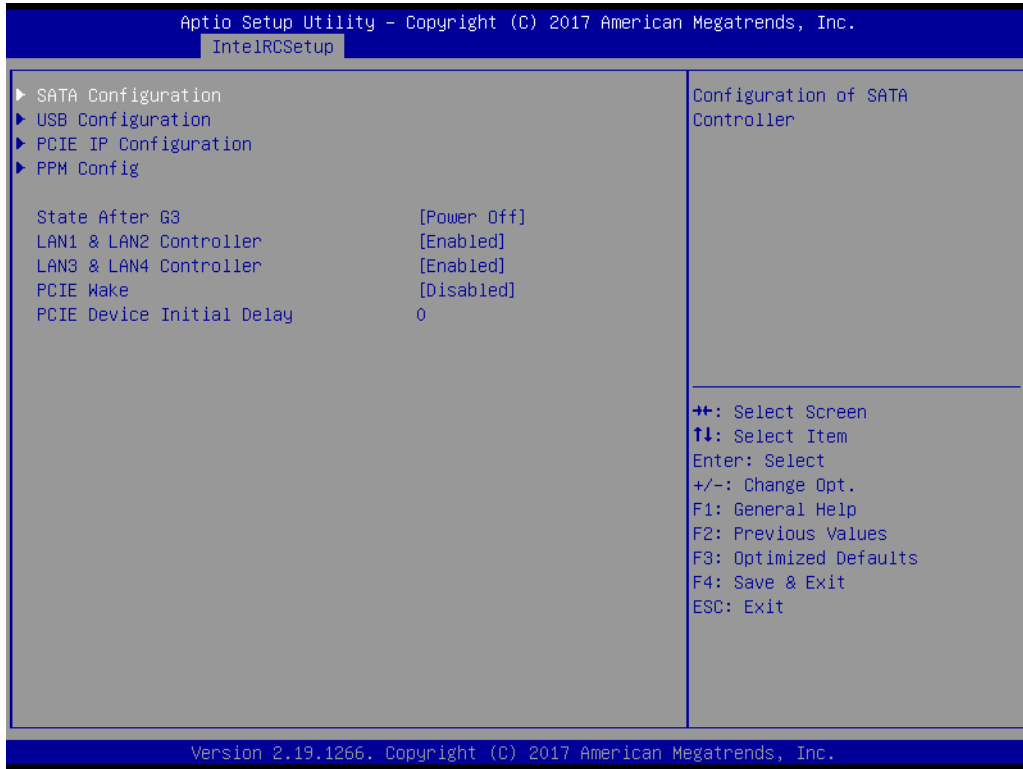


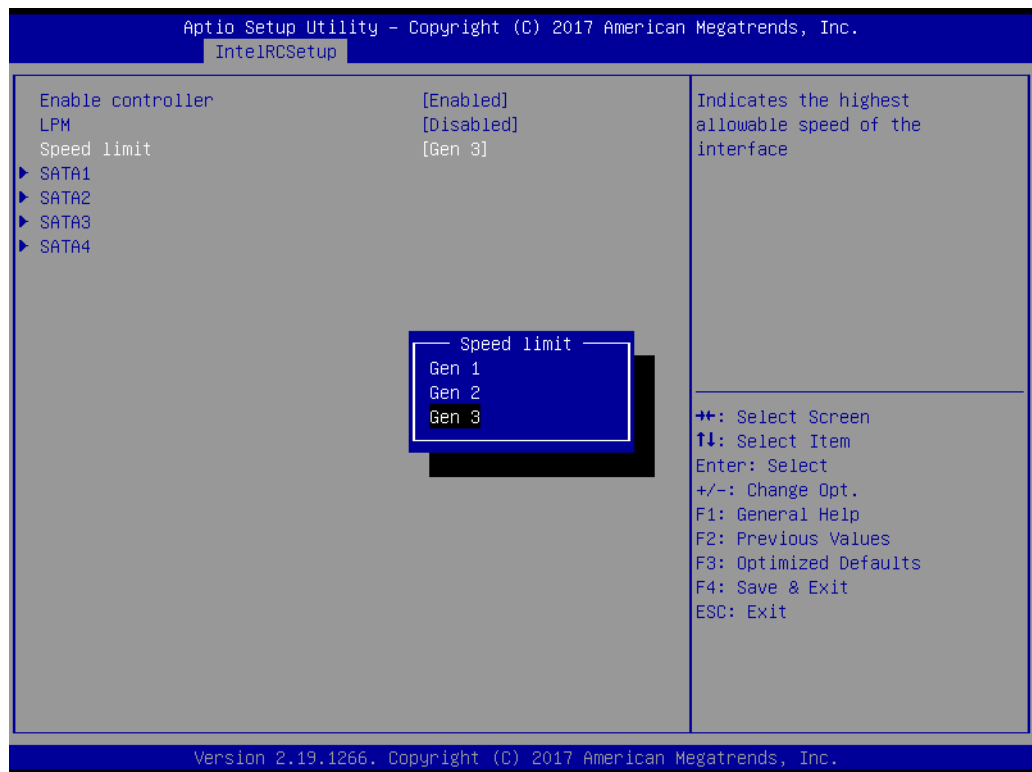
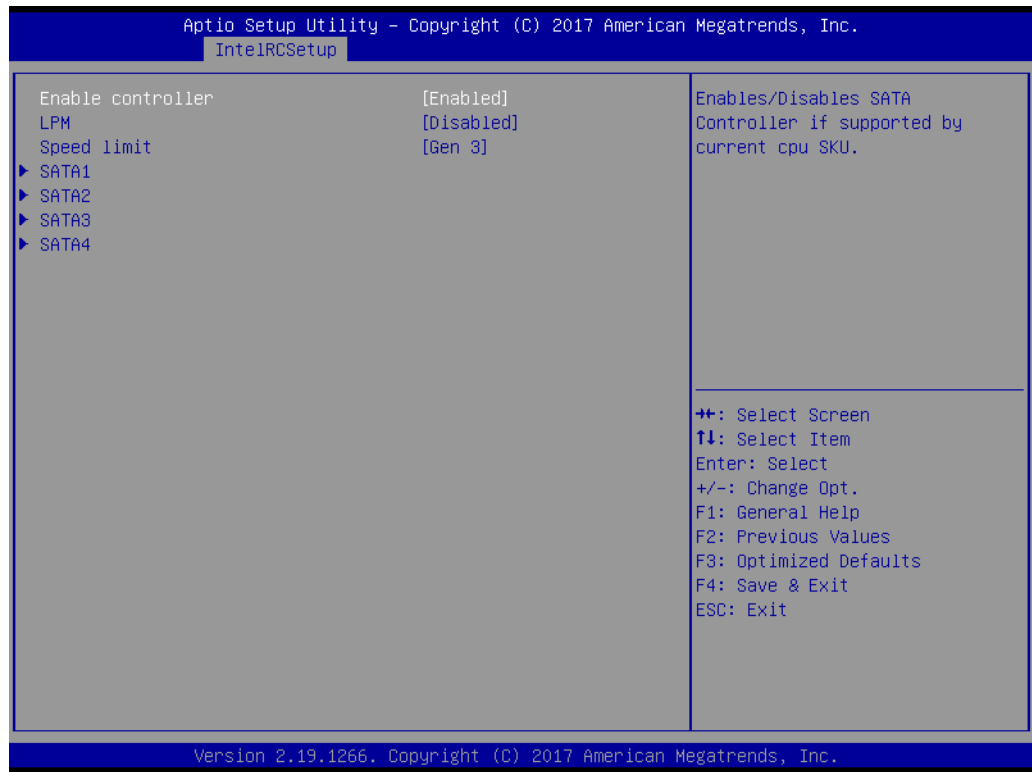
- **ECC Support**

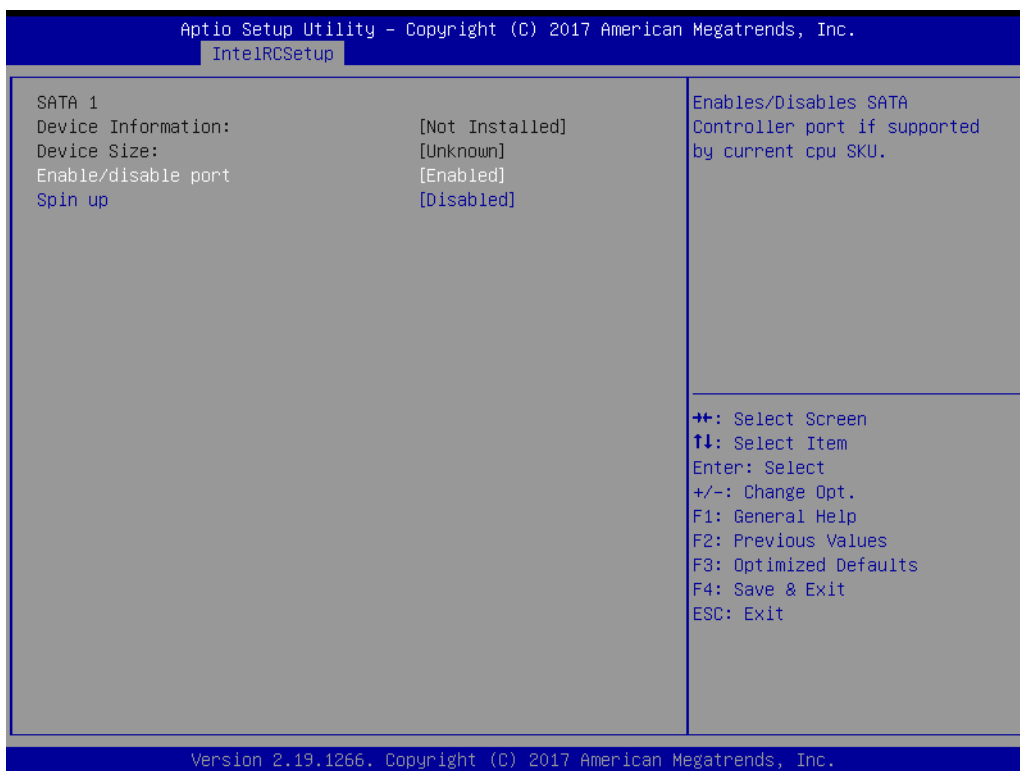
Enable or Disable ECC memory support (If the RAM don't support ECC, please don't open the ECC function, or the system will maybe have unexpected error.)



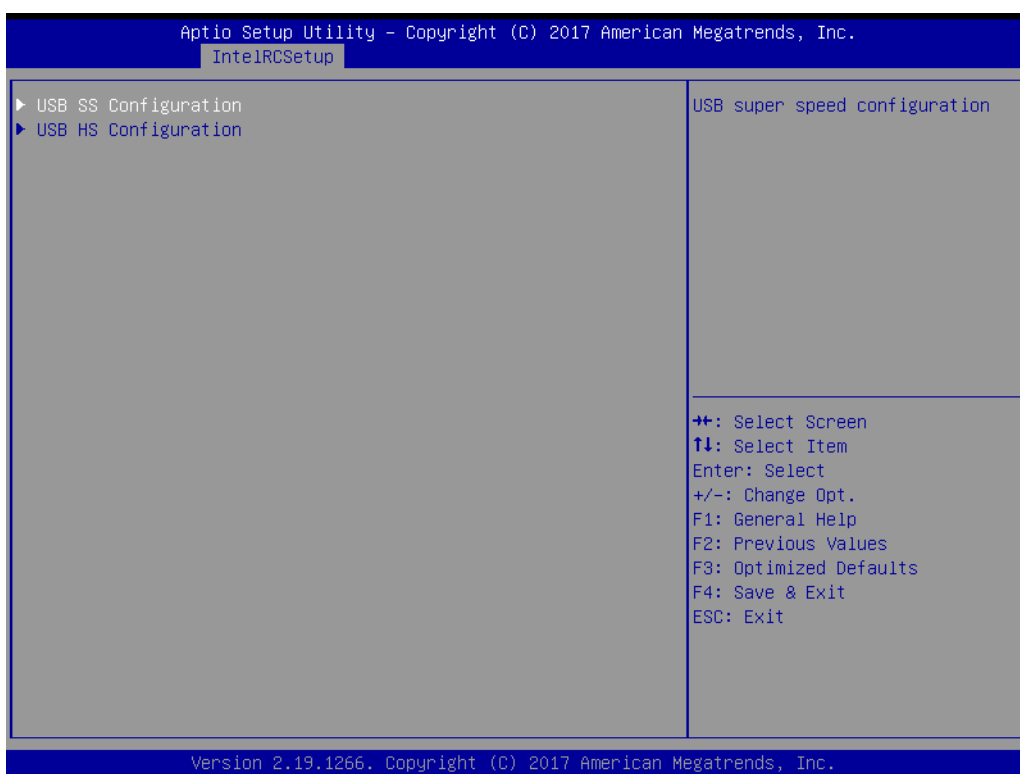
### 3.2.3.4 South Bridge Chipset Configuration

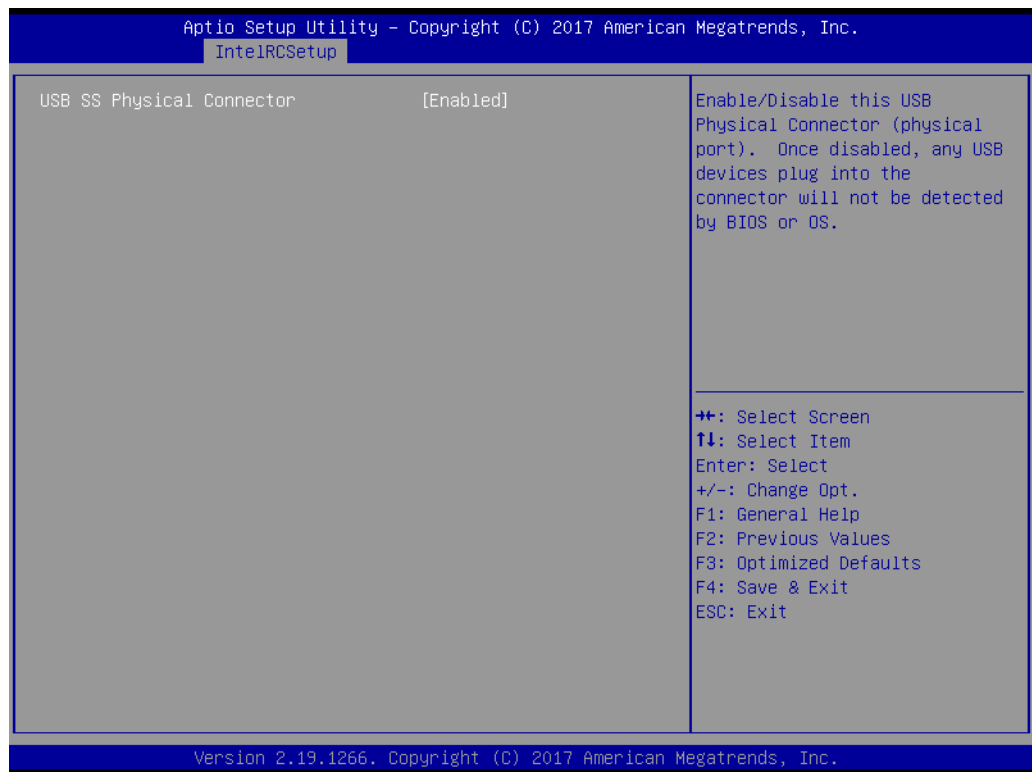
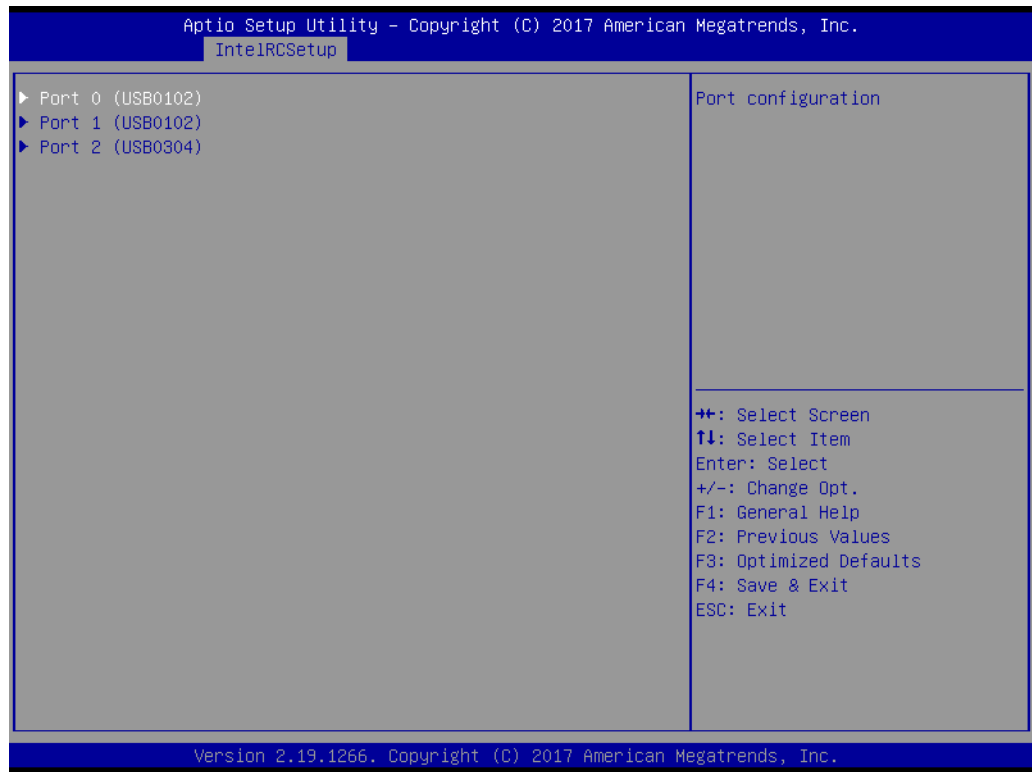


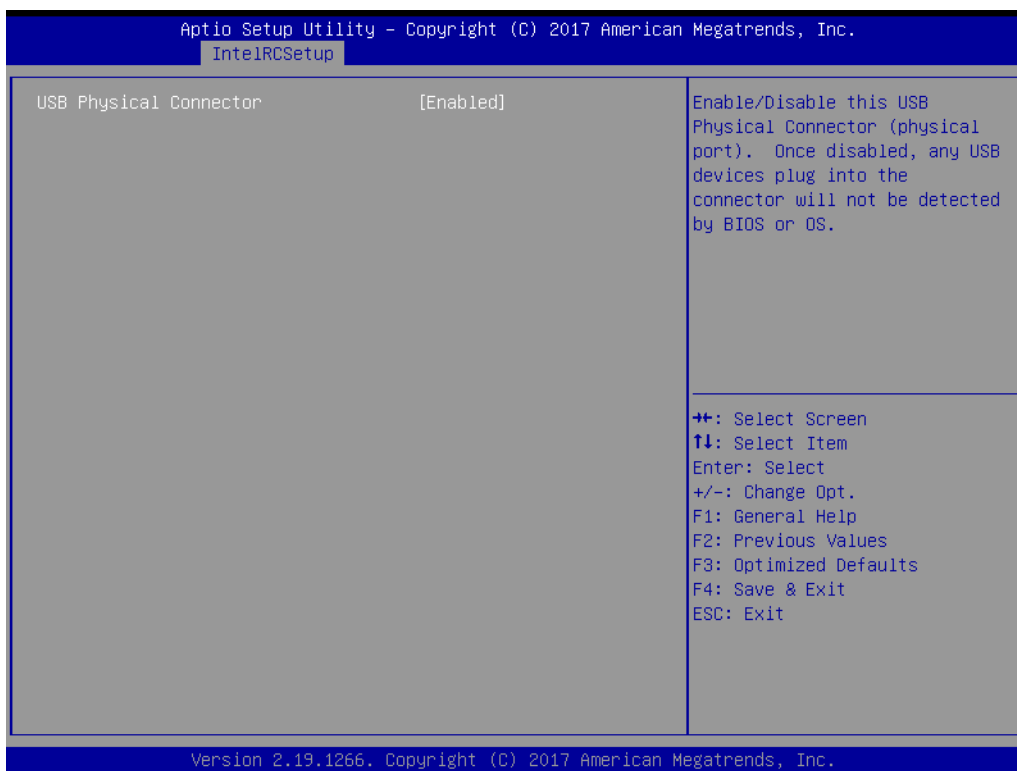
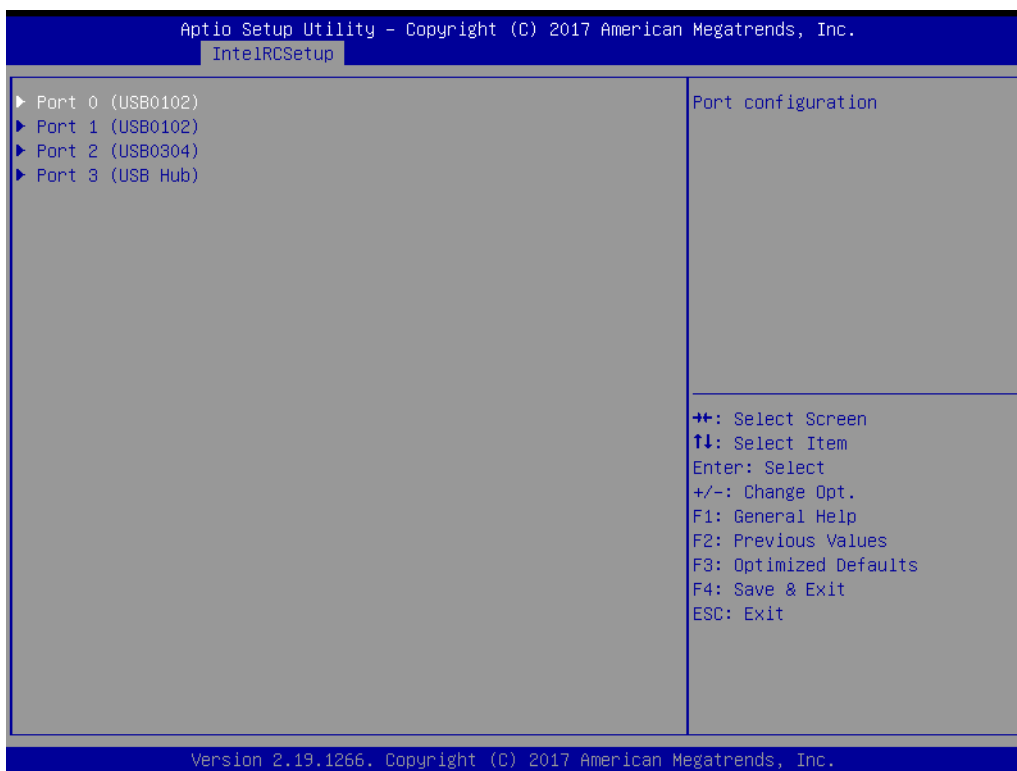


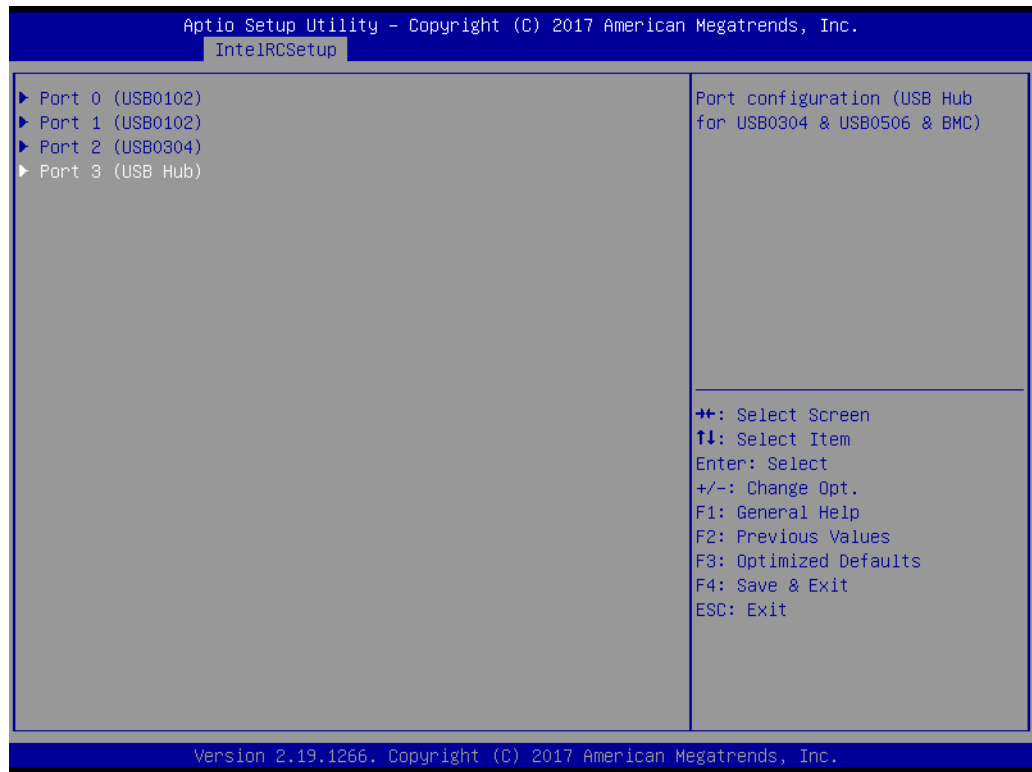


- **SATA Configuration**  
SATA ports information and settings.



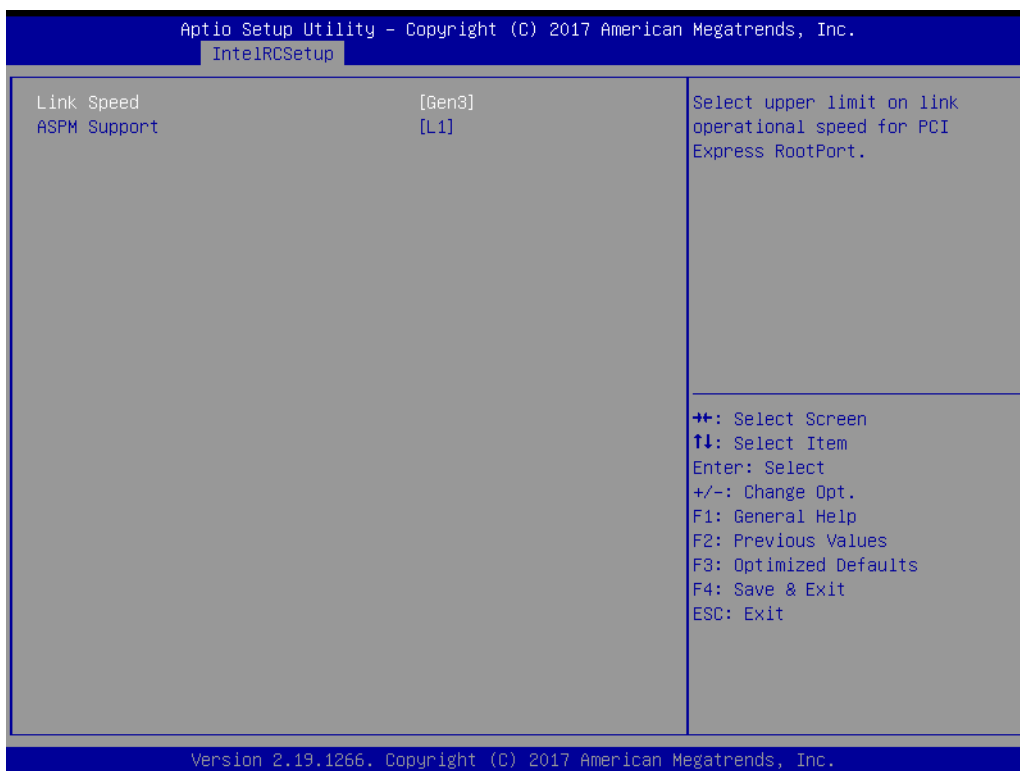
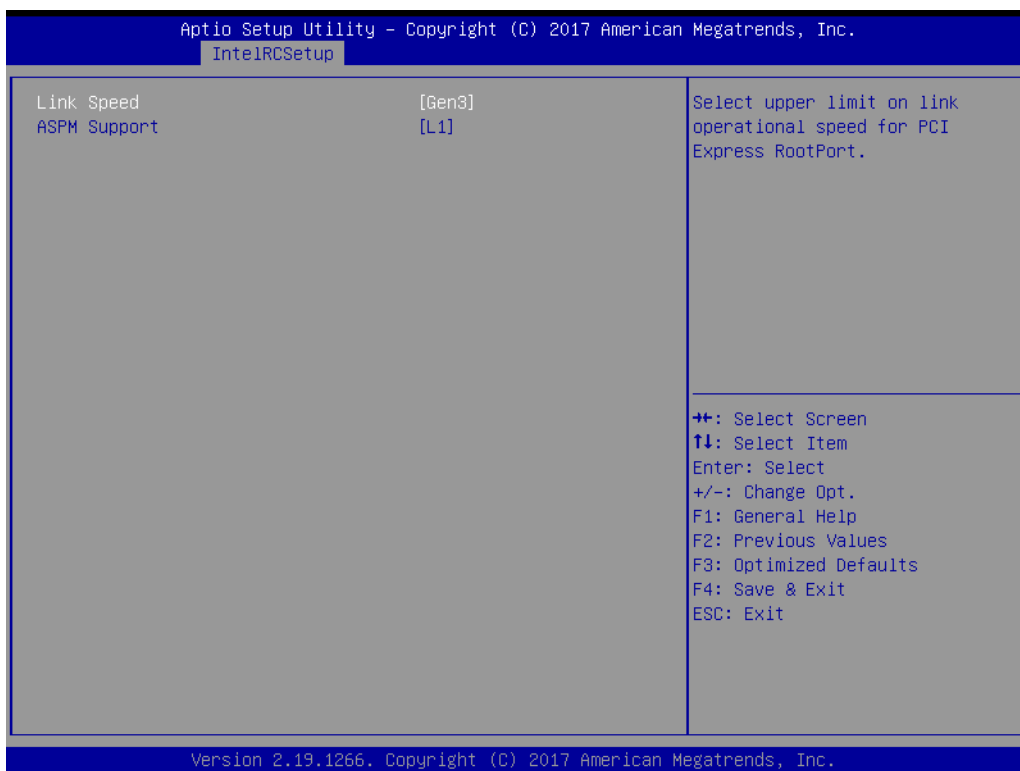




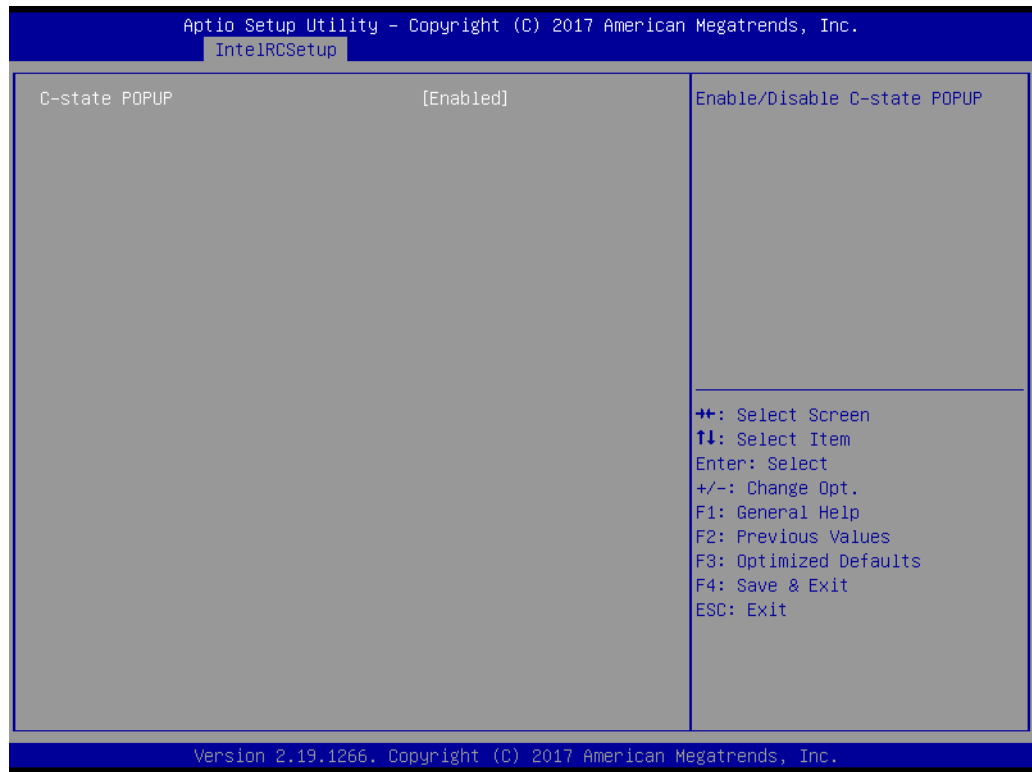


- **USB Configuration**  
USB ports information and settings.





- **PCIE IP Configuration**  
PCIE information and settings.



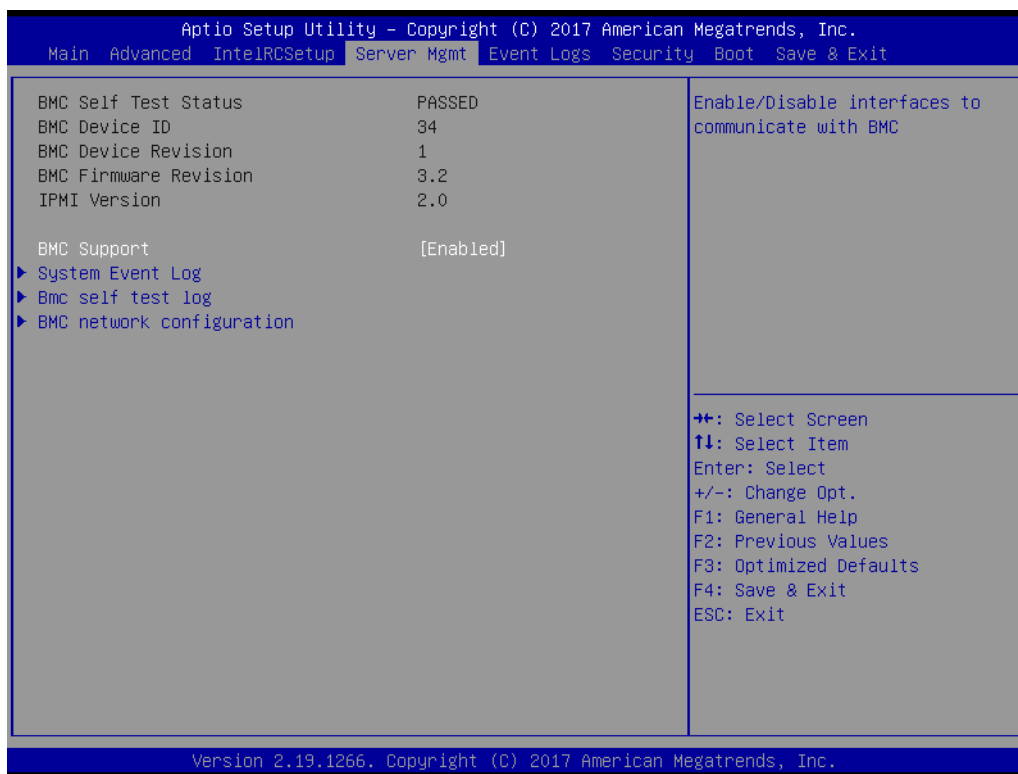
- **State After G3**  
Specify what state to go to when power is re-applied after a power failure (G3 state)
- **Lan1 & Lan2 Controller**  
Enable or Disable Lan1 & Lan2 ports.
- **Lan3 & Lan4 Controller**  
Enable or Disable Lan3 & Lan4 ports.



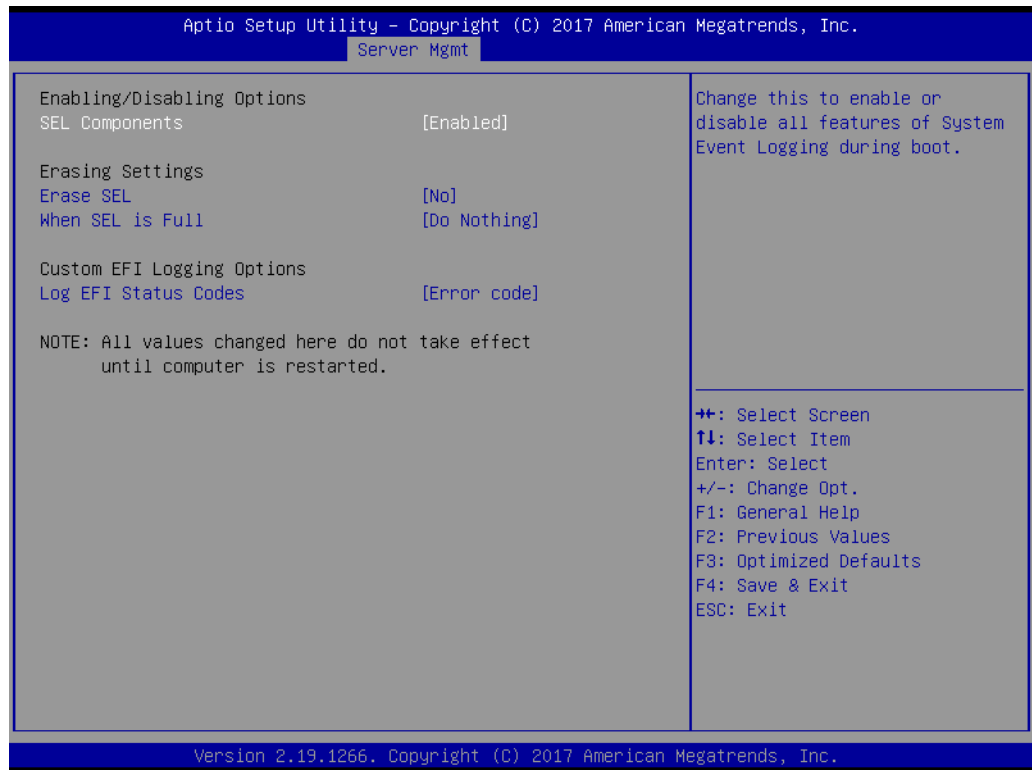
- **PCIE Wake**  
Enable or Disable PCIE to wake the system from S5

### 3.2.4 Server Mgmt

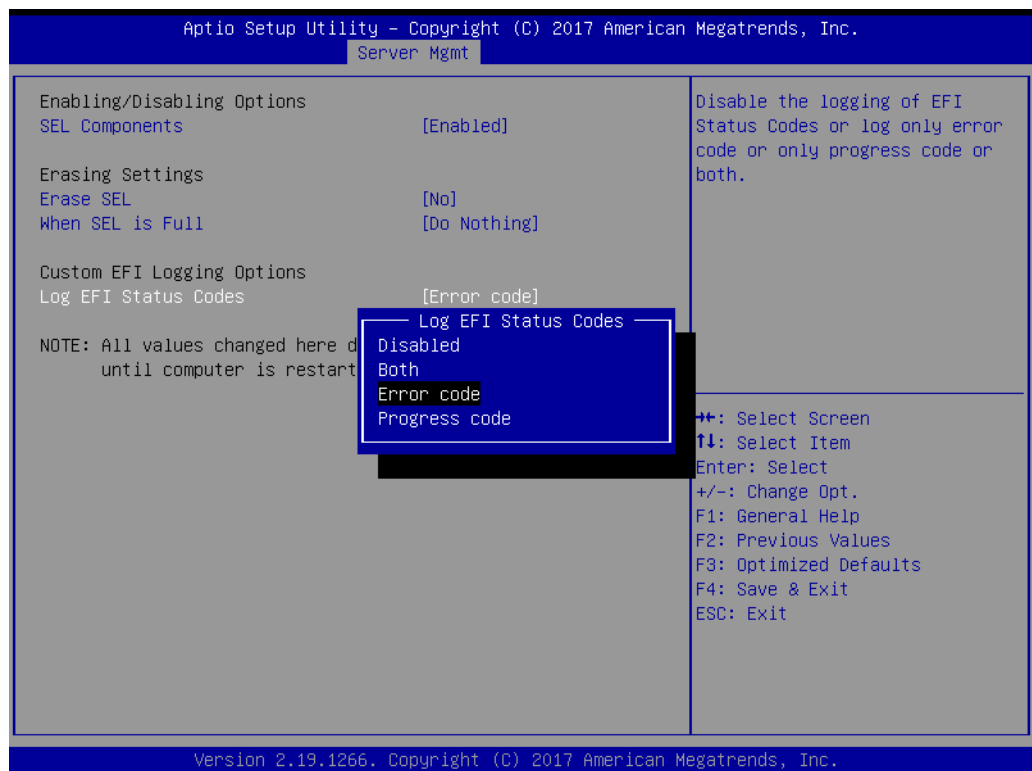
If your AIMB-290 can support IPMI, you can modify these setting to meet your demand.

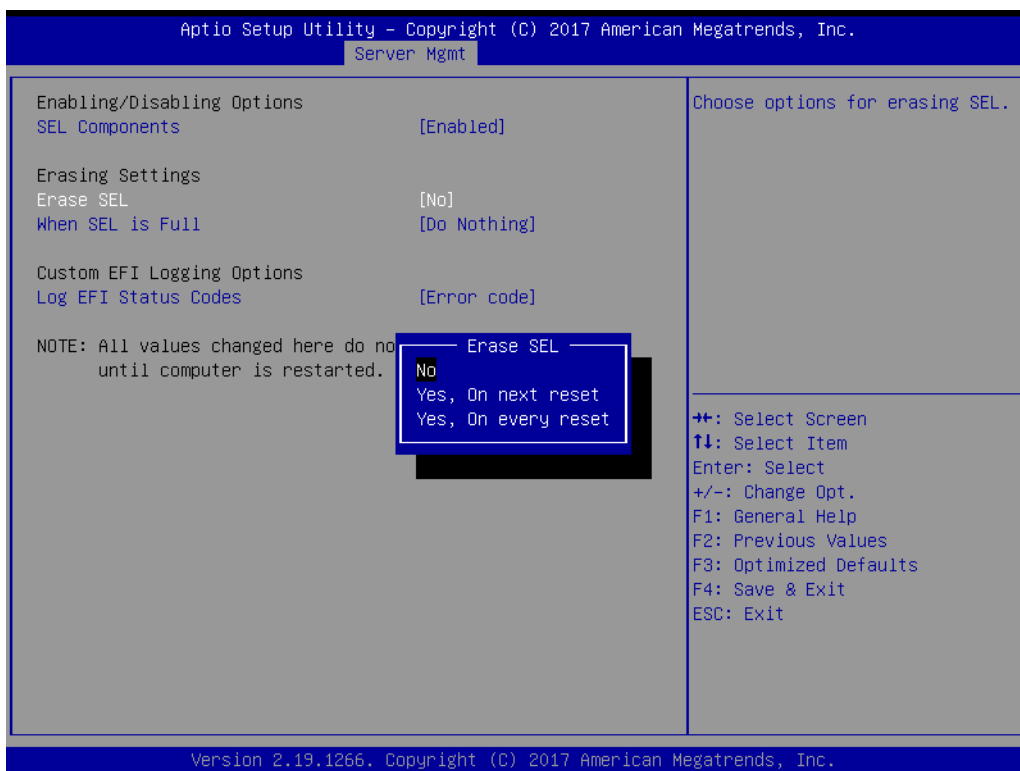
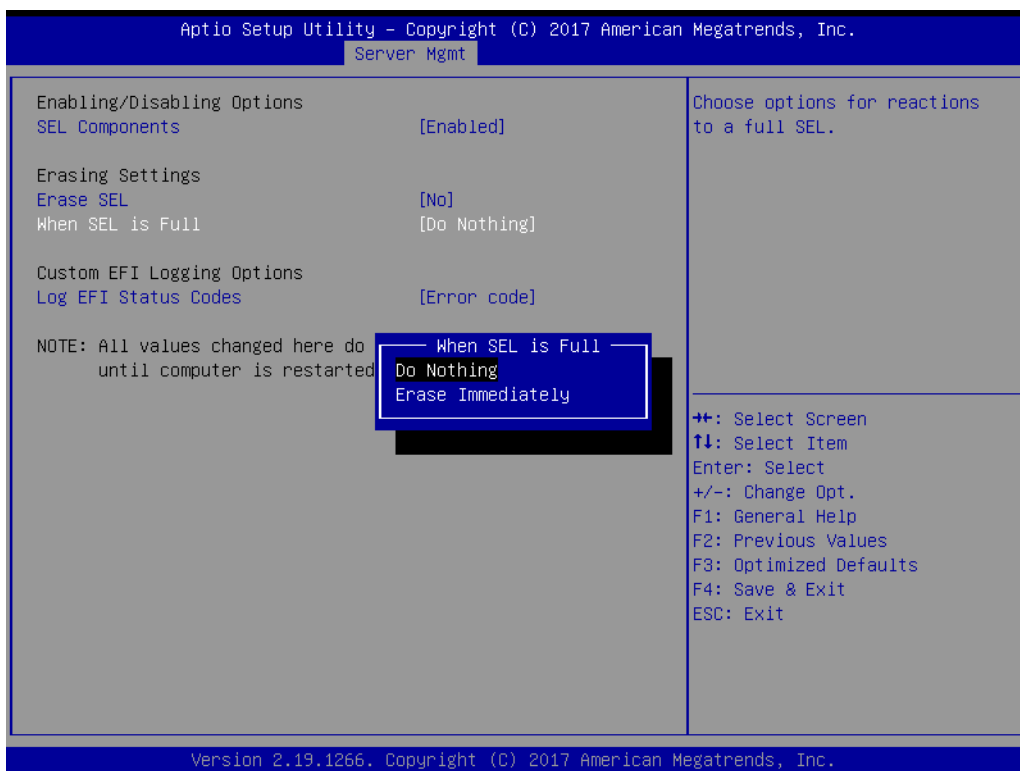


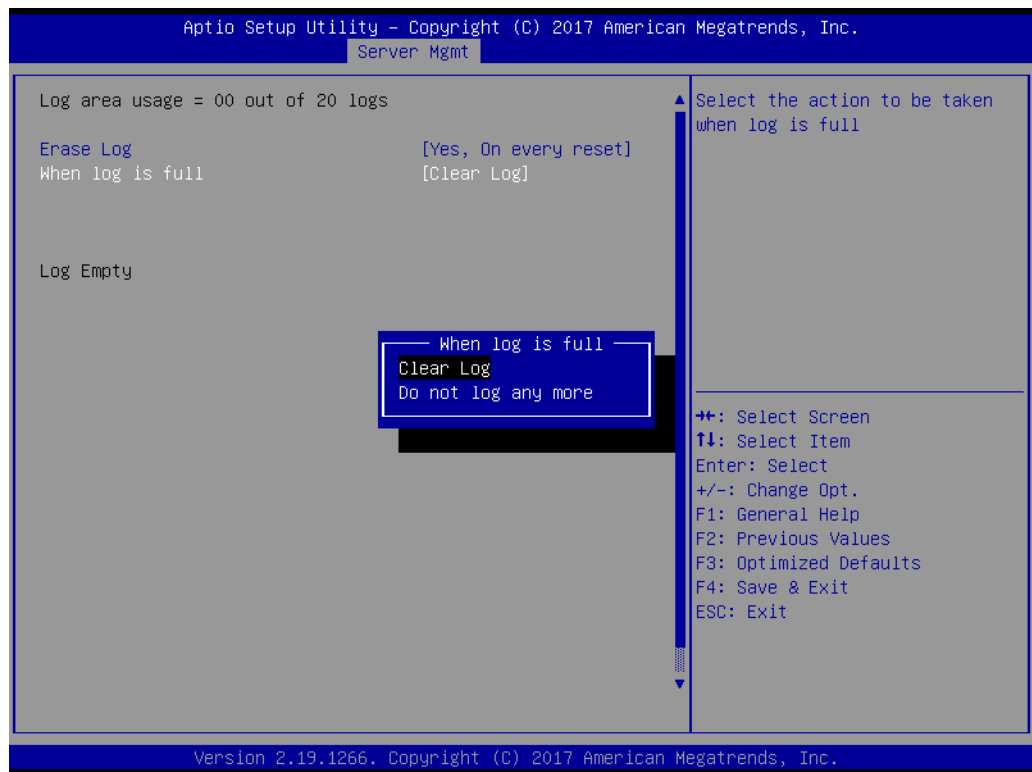
- **BMC Support**  
Enable or Disable BMC support.

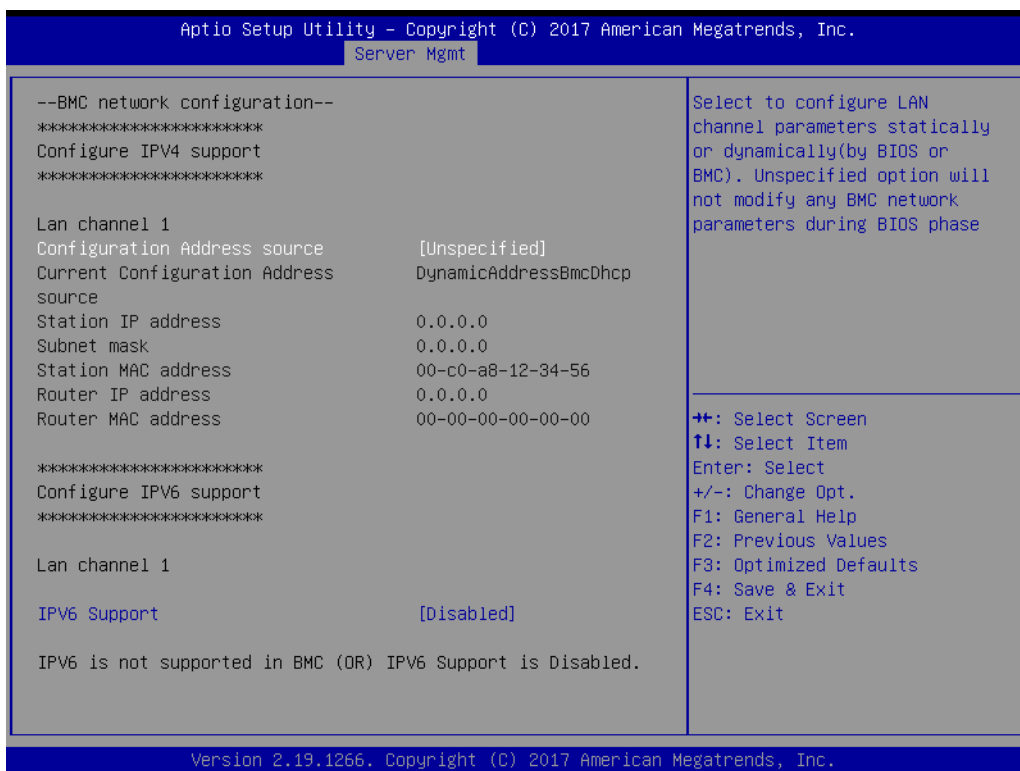
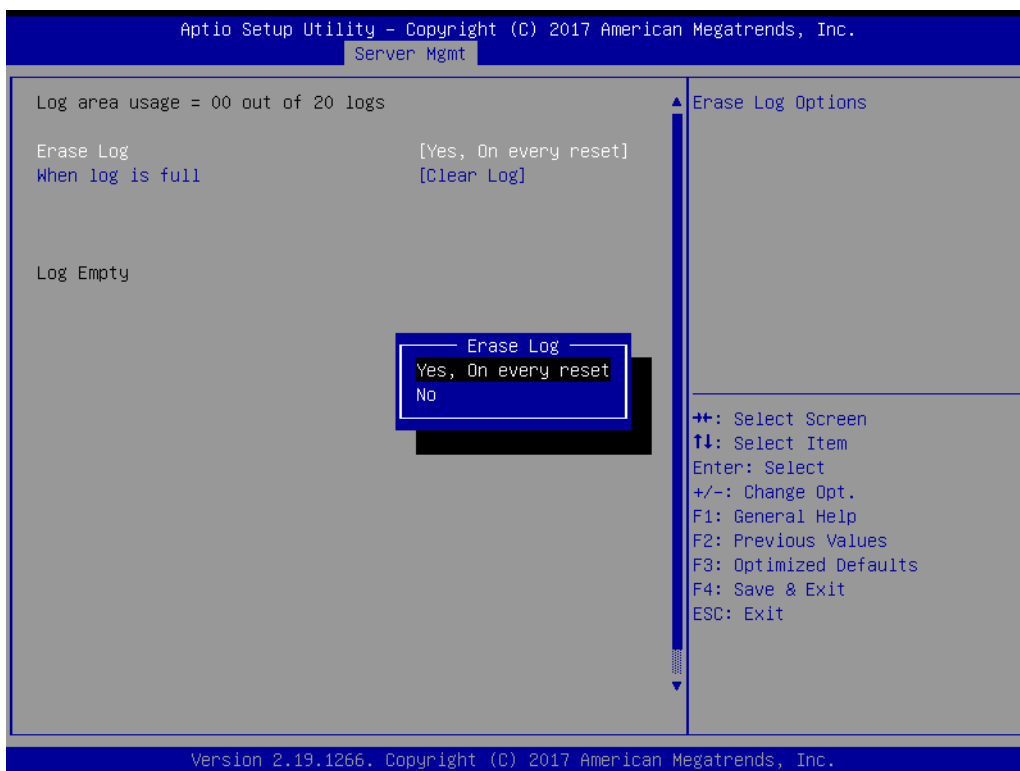


- **SEL Components**  
Enable or Disable SEL Components to Control via command.



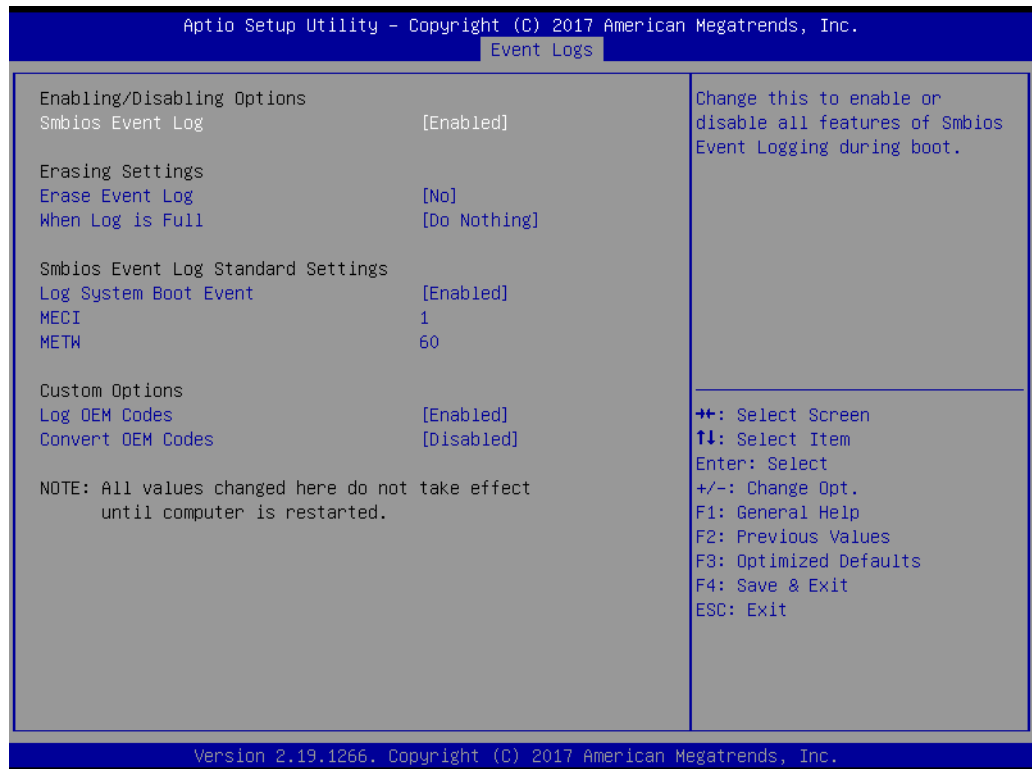
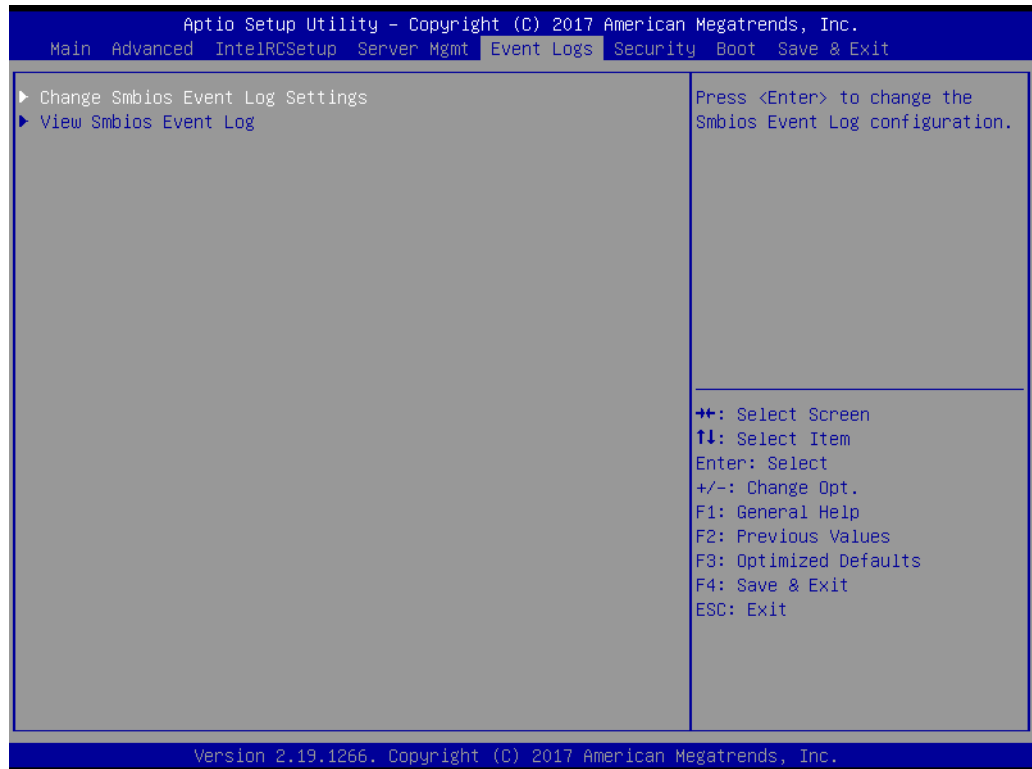


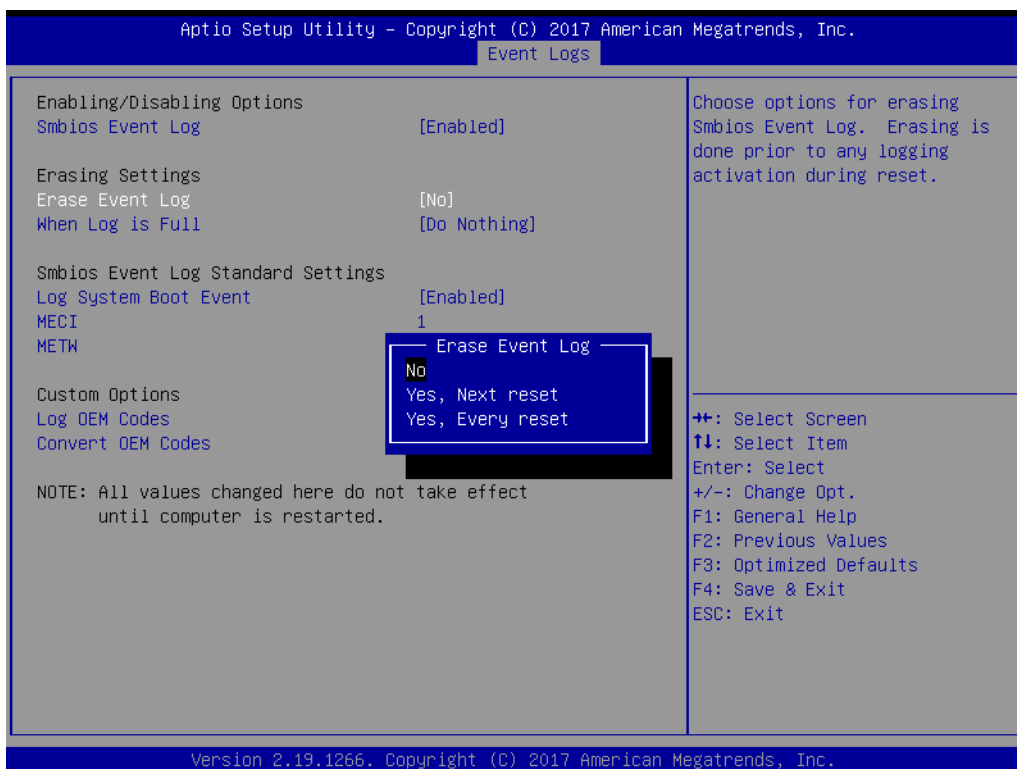
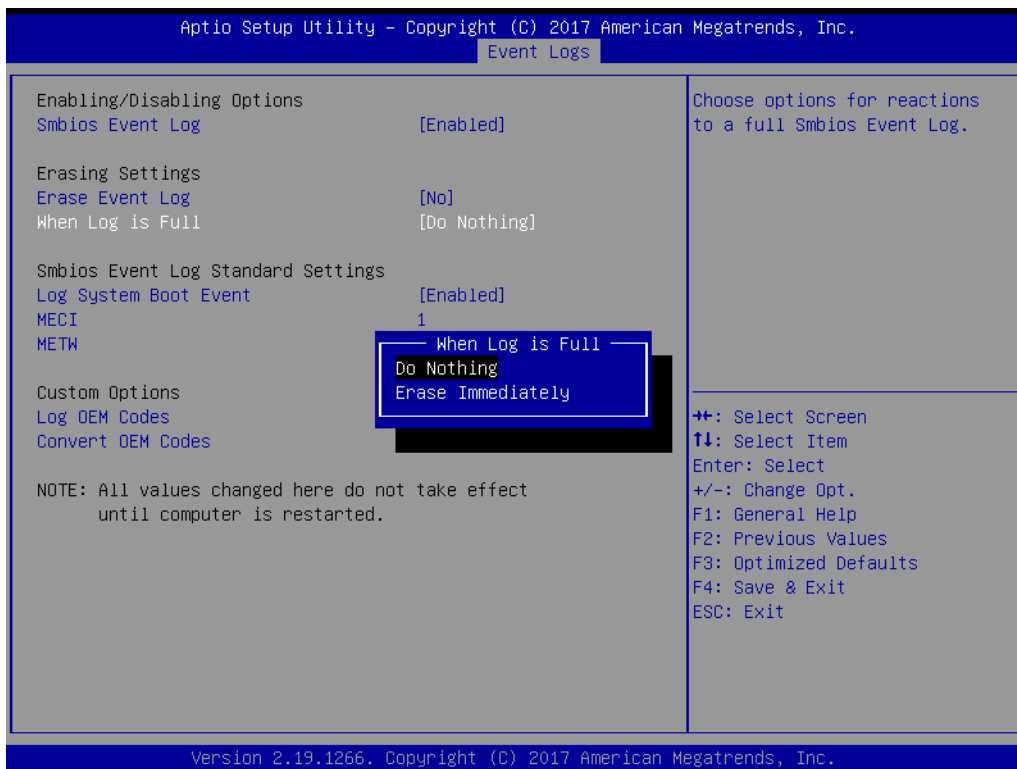


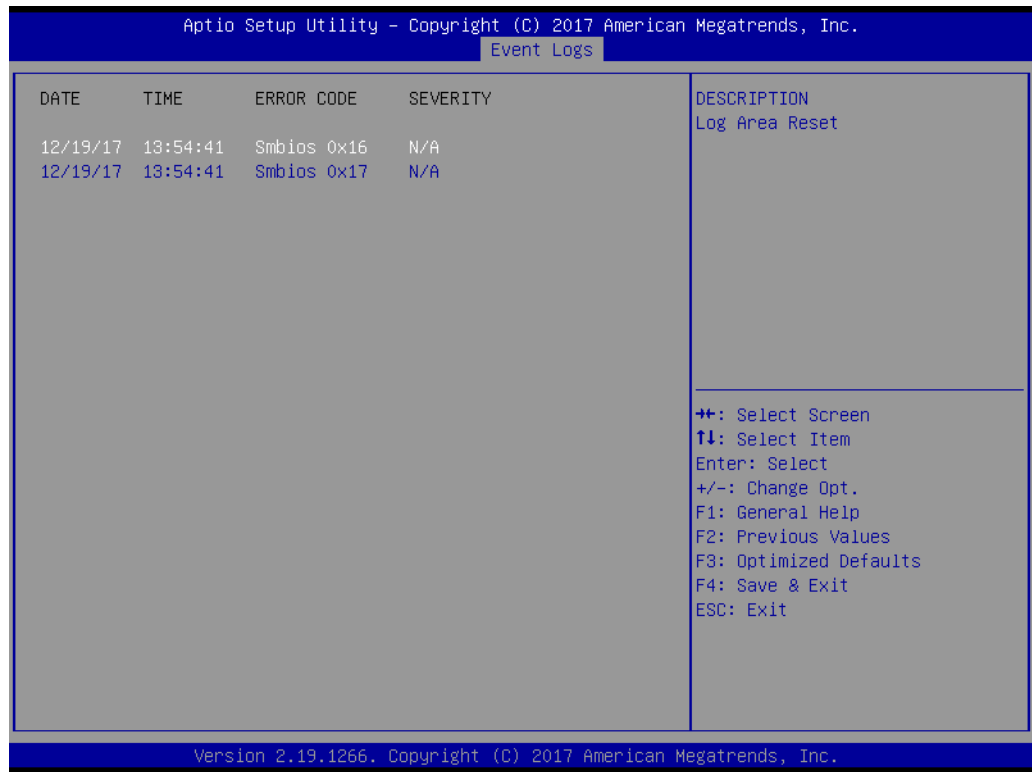


### 3.2.5 Event Logs

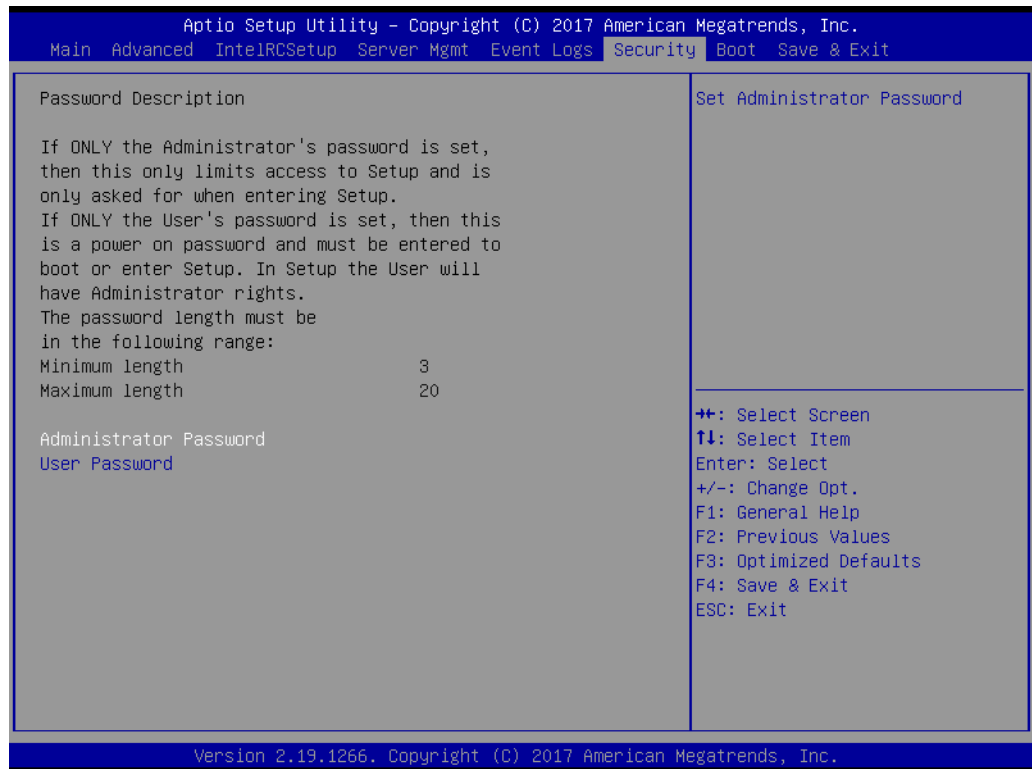
If your AIMB-290 can support IPMI, you can view event log to find out the failure operation. You can set these items to meet the your or environment demand.





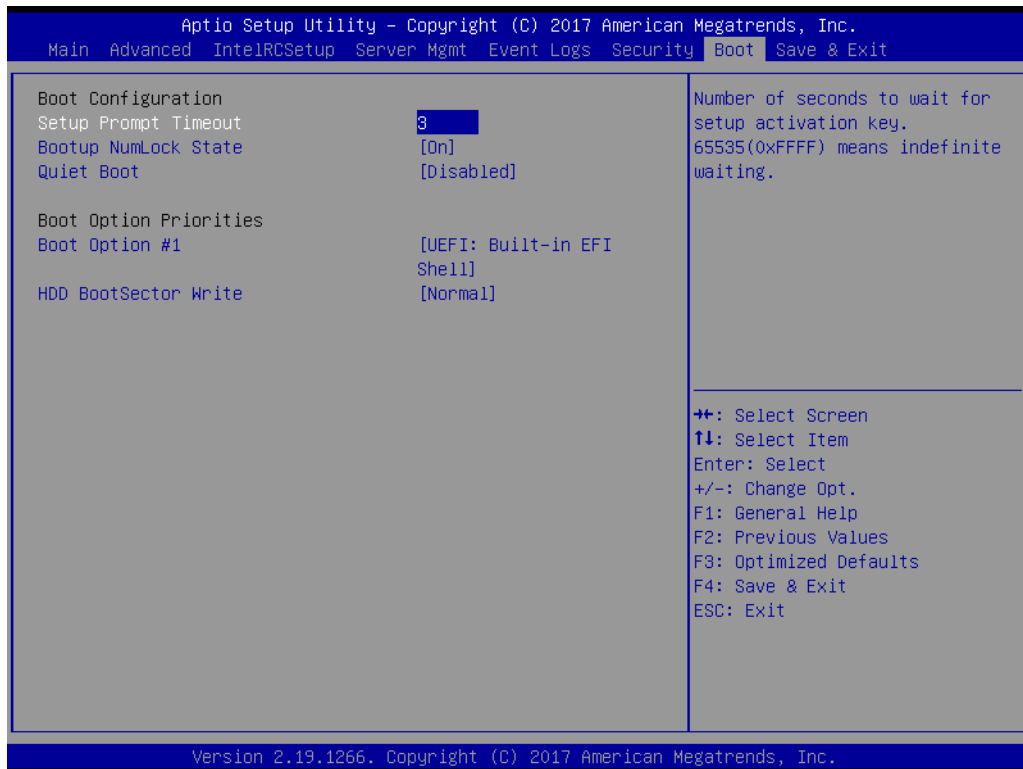


### 3.2.6 Security



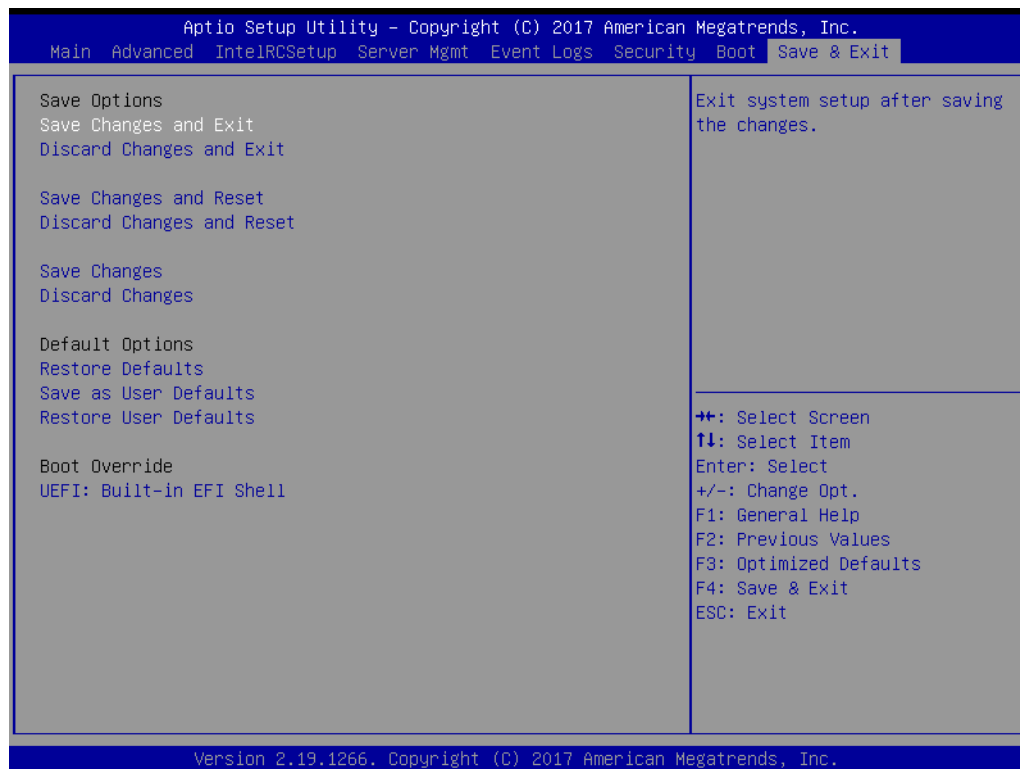


### 3.2.7 Boot



- **Setup Prompt Timeout [ 1 ]**  
Use the <+> and <-> keys to adjust the number of seconds to wait for setup activation key.
- **Bootup NumLock State**  
Select the keyboard NumLock state
- **Quiet Boot**  
Enable/disable quiet boot option

## 3.2.8 Save & Exit



### ■ Save Changes and Exit

When users have completed system configuration, select this option to save changes, exit BIOS setup menu and reboot the computer to take effect all system configuration parameters.

1. Select Exit Saving Changes from the Exit menu and press <Enter>. The following message appears: Save Configuration Changes and Exit Now? [Ok] [Cancel]
2. Select [Ok] or [Cancel].

### ■ Discard Changes and Exit

Select this option to quit Setup without making any permanent changes to the system configuration.

1. Select Exit Discarding Changes from the Exit menu and press <Enter>. The following message appears: Discard Changes and Exit Setup Now? [Ok] [Cancel]
2. Select [Ok] to discard changes and exit. Discard Changes  
Select Discard Changes from the Exit menu and press <Enter>.

### ■ Save Changes and Reset

When users have completed system configuration, select this option to save changes, exit BIOS setup menu and reboot the computer to take effect all system configuration parameters.

1. Select Exit Saving Changes from the Exit menu and press <Enter>. The following message appears: Save Configuration Changes and Exit Now? [Ok] [Cancel]
2. Select [Ok] or [Cancel].

### ■ Discard Changes and Reset

Select this option to quit Setup without making any permanent changes to the system configuration.

1. Select Reset Discarding Changes from the Exit menu and press <Enter>. The following message appears: Discard Changes and Exit Setup Now? [Ok] [Cancel]
  2. Select Ok to discard changes and reset. Discard Changes  
Select Discard Changes from the Exit menu and press <Enter>.
- **Restore Defaults**  
The BIOS automatically configures all setup items to optimal settings when users select this option. Defaults are designed for maximum system performance, but may not work best for all computer applications. In particular, do not use the Defaults if the user's computer is experiencing system configuration problems. Select Restore Defaults from the Exit menu and press <Enter>.
  - **Save as User Default**  
Save the all current settings as a user default.
  - **Restore User Default**  
Restore all settings to user default values.



# Chapter 4

Software Introduction  
& Service

## 4.1 Introduction

The mission of Advantech Server Software Services is to "Enhance quality of life with Advantech platforms and Microsoft® Windows® server technology" We enable Windows® server software products on Advantech platforms to more effectively support the server computing community. Customers are freed from the hassle of dealing with multiple vendors (hardware suppliers, system integrators, OS distributors) for projects. Our goal is to make Windows® Server solutions easily and widely available to the embedded computing community.

## 4.2 Value-Added Software Services

Software API: An interface that defines the ways by which an application program may request services from libraries and/or operating systems. Provides not only the underlying drivers required but also a rich set of user-friendly, intelligent and integrated interfaces, which speeds development, enhances security and offers add-on value for Advantech platforms. It plays the role of catalyst between developer and solution, and makes Advantech embedded platforms easier and simpler to adopt and operate with customer applications.

### 4.2.1 Software API

#### 4.2.1.1 Control

##### GPIO



General Purpose Input/Output is a flexible parallel interface that allows a variety of custom connections. It allows users to monitor the level of signal input or set the output status to switch on/off the device. Our API also provides Programmable GPIO, which allows developers to dynamically set the GPIO input or output status.

##### SMBus



SMBus is the System Management Bus defined by Intel Corporation in 1995. It is used in personal computers and servers for low-speed system management communications. The SMBus API allows a developer to interface a embedded system environment and transfer serial messages using the SMBus protocols, allowing multiple simultaneous device control.

#### 4.2.1.2 Monitor

##### Watchdog



A watchdog timer (WDT) is a device that performs a specific operation after a certain period of time if something goes wrong and the system does not recover on its own. A watchdog timer can be programmed to perform a warm boot (restarting the system) after a certain number of seconds.

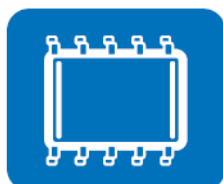
##### Hardware Monitor



The Hardware Monitor (HWM) API is a system health supervision API that inspects certain condition indexes, such as fan speed, temperature and voltage.

#### 4.2.2 Software Utility

##### BIOS Flash



The BIOS Flash utility allows customers to update the flash ROM BIOS version, or use it to back up current BIOS by copying it from the flash chip to a file on the customers' disk. The BIOS Flash utility also provides a command line version and an API for fast implementation into customized applications.

##### Monitoring



Monitoring is a utility for customers to monitor system health, like voltage, CPU and system temperature and fan speed. These items are important to a device, if critical errors occur and are not solved immediately, permanent damage may be caused.





# Chapter 5

Chipset Software  
Installation Utility

---

## 5.1 Before You Begin

To facilitate the installation of the enhanced display drivers and utility software, read the instructions in this chapter carefully. The drivers for AIMB-290 are located on Advantech website. (<http://support.advantech.com/Support/>.) Updates are provided via Service Packs from Microsoft\*.

Before you begin, it is important to note that most display drivers need to have the relevant software application already installed in the system prior to installing the enhanced display drivers. In addition, many of the installation procedures assume that you are familiar with both the relevant software applications and operating system commands. Review the relevant operating system commands and the pertinent sections of your application software's user manual before performing the installation.

## 5.2 Introduction

The Intel® Chipset Software Installation (CSI) utility installs the Windows INF files that outline to the operating system how the chipset components will be configured. This is needed for the proper functioning of the following features:

## 5.3 Windows Server 2016 Driver Setup

1. When enter the website of Advantech, then search product AIMB-290. There is "Chipset" driver inside.



**ADVANTECH**

*Enabling an Intelligent Planet*

**[www.advantech.com](http://www.advantech.com)**

Please verify specifications before quoting. This guide is intended for reference purposes only.

All product specifications are subject to change without notice.

No part of this publication may be reproduced in any form or by any means, electronic, photocopying, recording or otherwise, without prior written permission of the publisher.

All brand and product names are trademarks or registered trademarks of their respective companies.

© Advantech Co., Ltd. 2018