

# Acknowledgment Letter



SPECIFICATION FOR APPROVAL

:  
CUSTOMER: **Shenzhen Yixunda Technology Co., Ltd**

---

:  
CUST P/N: **10.0110.0995**

---

:  
FINE P/N: **G4511-6.5UH single coil 0.08 \* 24P \* 2 \* 10TS**

---

DESC: **Diameter 45MMX5.0MMX0.8MM slotted**

---

:  
DATE: **May 23, 2024**

---

:  
Version: **A.0**

---



PREPARED BY	CHECKED BY	APPROVED BY	CUSTOMER APPROVE
Huang Yanming	Huang Dongming	Huang Jinhua	

## Dongguan Xilian Gancheng Technology Co., Ltd

Factory address: 8th floor, Building 2, Sanjia High tech Industrial Park, No. 123 Junfa Road, Dongkeng Town, Dongguan City

TEL: 0769-82989159

FAX: 0769-82989159

E-mail: [aming198204@163.com](mailto:aming198204@163.com)



# SPECIFICATION

DESC:	<b>Φ20.5x40-6.5uH-0.08x24P-50mm</b>	Rev: A.0	CUST:	
			CUST P/N:	

one、DIMENSION:(mm)

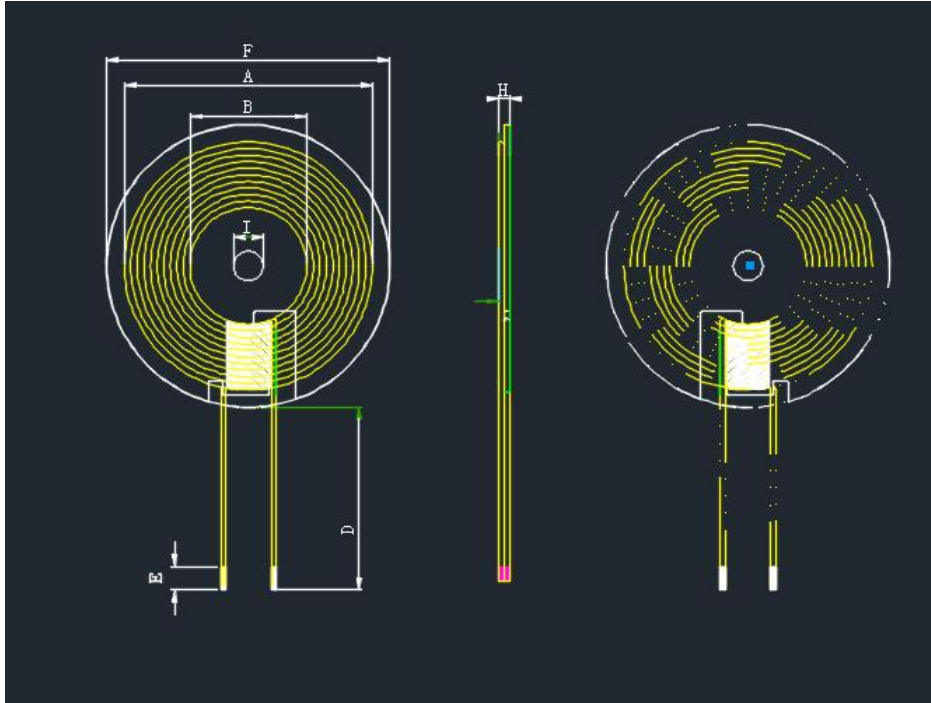

A	39.5±1.0
B	20.5±0.5
D	50±2
E	3±2
F	43.5±0.5
H	1.6±0.2
I	5.3±0.2

Note:

1. Cross outgoing line;
2. Wrap 8mm (ref) wide high-temperature adhesive paper 1-2Ts around the outlet position;
3. The coil is covered with circular hard magnetic plates with slots, with a magnetic plate size of  $43.5 \pm 0.5$ mm, an inner hole of 5.2mm, and a thickness of  $0.8 \pm 0.2$ mm.

two、SCHEMATIC DIAGRAM:

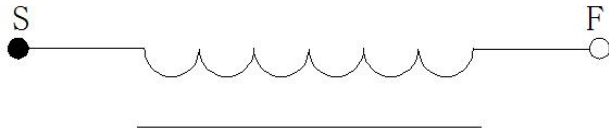

three、Winding Specification:

NO.	TERMINAL		WIRE	Turns	Winding Direction
1	S	F	Enamel wire 0.08 * 24PX2 10Ts	10Ts	CCW

four、ELECTRICAL CHARACTERISTICS:

TEMPERATURE:25±10°C, RELATIVE HUMIDITY:65±20%

NO.	ITEM	TERMINAL	SPECIFICATION	TEST FREQUENCY	TEST EQUIPMENTS
1	IND.	S-F	$3.8\mu\text{H} \pm 20\%$ individual coil	100KHz/1.0V	LCZ METER 1062B
2	IND.	S-F	$6.5\mu\text{H} \pm 10\%$ magnetic disc	100KHz/1.0V	LCZ METER 1062B
3	DCR	S-F	$\leq 90\text{m}\Omega$	100KHz/1.0V	LCZ METER 502B
4	Q	S-F	$\geq 39$	100KHz/1.0V	LCZ METER 502B

PREPARED BY/DATE	CHECKED BY/DATE
Huang Yanming May 23, 2024	Huang Jinhua May 23, 2024