

TP-LINK®

User Guide

TL-SG1008

8-Port Gigabit Switch

TL-SG1016D

16-Port Gigabit Switch

TL-SG1024D

24-Port Gigabit Switch

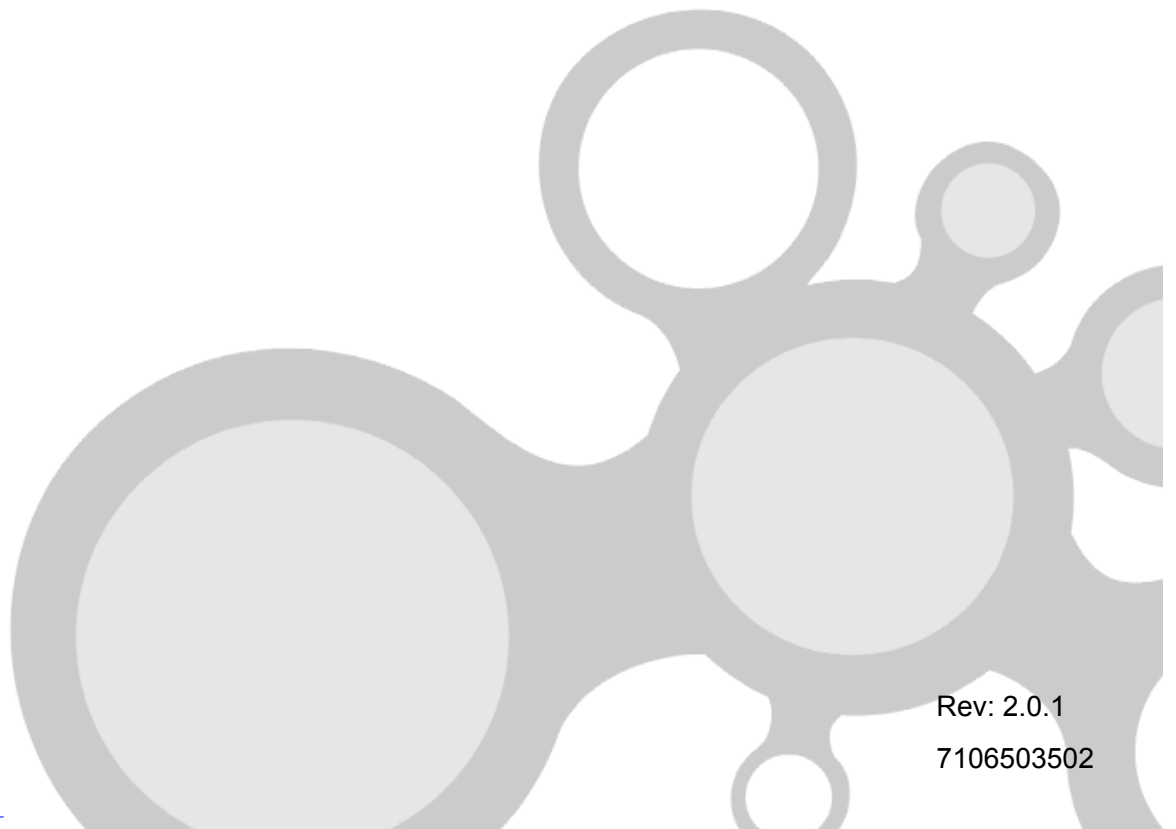

Rev: 2.0.1

7106503502

COPYRIGHT & TRADEMARKS

Specifications are subject to change without notice. **TP-LINK**[®] is a registered trademark of TP-LINK TECHNOLOGIES CO., LTD. Other brands and product names are trademarks or registered trademarks of their respective holders.

No part of the specifications may be reproduced in any form or by any means or used to make any derivative such as translation, transformation, or adaptation without permission from TP-LINK TECHNOLOGIES CO., LTD. Copyright © 2011 TP-LINK TECHNOLOGIES CO., LTD. All rights reserved.

<http://www.tp-link.com>

FCC STATEMENT



This equipment has been tested and found to comply with the limits for a Class A digital device, pursuant to part 15 of the FCC Rules. These limits are designed to provide reasonable protection against harmful interference when the equipment is operated in a commercial environment. This equipment generates, uses, and can radiate radio frequency energy and, if not installed and used in accordance with the instruction manual, may cause harmful interference to radio communications. Operation of this equipment in a residential area is likely to cause harmful interference in which case the user will be required to correct the interference at his own expense.

This device complies with part 15 of the FCC Rules. Operation is subject to the following two conditions:

- 1) This device may not cause harmful interference.
- 2) This device must accept any interference received, including interference that may cause undesired operation.

Any changes or modifications not expressly approved by the party responsible for compliance could void the user's authority to operate the equipment.

CE Mark Warning



This is a class A product. In a domestic environment, this product may cause radio interference, in which case the user may be required to take adequate measures.



Note:

As for TL-SG1008, a fuse resistor is used in the "F1" position on the PCB of the power module. The fuse resistor should be used with the following type: 10ohm 2W@25°C.

CONTENTS

Package Contents.....	1
Chapter 1 Product Introduction	2
1.1 Product Overview.....	2
1.2 Features	2
Chapter 2 Identifying External Components.....	3
2.1 Front Panel.....	3
2.2 Rear Panel	3
Chapter 3 Installation	4
3.1 Precautions	4
3.2 Installation	4
3.2.1 Desktop Installation	5
3.2.2 Rack Installation.....	5
3.3 Connect to Ground	7
3.4 Power on	8
Appendix A: Specifications	9
Appendix B: Troubleshooting.....	11
Appendix C: Contact Information	11

Package Contents

The following contents should be found in your package:

- One TL-SG1008/TL-SG1016D/TL-SG1024D Switch
- One power cord
- This User Guide
- Rubber footpads for Desk-mount
- Mounting screws and two “L” planks



Note:

Make sure that the package contains the above items. If any of the listed items are damaged or missing, please contact with your distributor. TL-SG1016D and TL-SG1024D do not include mounting screws and two “L” planks.

Chapter 1 Product Introduction

This chapter describes the features of the TL-SG1008/TL-SG1016D/TL-SG1024D Switch.

1.1 Product Overview

The TL-SG1008/TL-SG1016D/TL-SG1024D Switch provides you with a high-performance, low-cost, easy-to-use, seamless and standard upgrade to boost your old network to 1000Mbps. Increase the speed of your network server and backbone connections make Gigabit a reality. Power users in the home, office, workgroup, or creative production environment can now move large, bandwidth-intensive files faster. Transfer graphics, CGI, CAD, or multimedia files and other applications that have to move large files across the network almost instantly.

The TL-SG1008/TL-SG1016D/TL-SG1024D Switch features a non-blocking switching architecture that forwards and filters packets at full wire-speed for maximum throughput, MAC address auto-learning and auto-aging, IEEE802.3x flow control for full-duplex mode and backpressure for half-duplex mode. It is compatible with all 10,100 and 1000Mbps Ethernet devices because it is standard-based. It protects your existing network investments while providing you with a straightforward migration path to faster Gigabit speeds.

The TL-SG1008/TL-SG1016D/TL-SG1024D Switch is plug-and-play and no configuration is required. Auto MDI/MDI-X cable detection on all ports eliminate the need for crossover cable or Uplink port. Each port can be used as general ports or Uplink ports, and any port can be simply plugged into a server, a hub, a router or a switch, using the straight cable or crossover cable. Diagnostic LEDs which display link status and activity, allowing you to quickly detect and correct problems on the network.

1.2 Features

- Complies with IEEE802.3, IEEE802.3u, IEEE802.3ab standards
- 8/16/24 10/100/1000Mbps Auto-Sense RJ45 ports supporting Auto-MDI/MDIX
- All ports Support Full/Half Duplex transfer mode for 10/100Mbps and Full Duplex transfer mode for 1000Mbps
- Supports IEEE802.3x flow control for full-duplex mode and backpressure for half-duplex transfer mode
- Non-blocking switching architecture that forwards and filters packets at full wire-speed for maximum throughput
- Supports MAC address auto-learning and auto-aging
- LED indicators for monitoring power, link, speed and activity
- Desktop and rack-mountable steel case
- Internal power supply

Chapter 2 Identifying External Components

This Chapter describes the front panel, rear panel and LED indicators of the Switch. TL-SG1008/TL-SG1016D/TL-SG1024D just differ in the number of LED indicators and ports and all figures in this guide are of TL-SG1008.

2.1 Front Panel

The front panel of TL-SG1008 consists of switch model, switch LED indicators, and 8 10/100/1000Mbps RJ-45 ports.

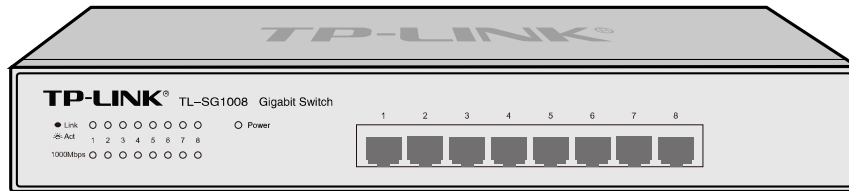



Figure 2-1 TL-SG1008 Switch Front Panel sketch

The LED indicators include Power, Link/Act LED indicators, which are used for monitoring and pre-troubleshooting of the Switch. The following section shows the LED indicators of the Switch along with an explanation of each indicator.

- **POWER LED:** This indicator will light solid red when the Switch powers up. If the LED is not lit, please check the power supply and connection.
- **Link/Act LED:** The LED indicates Link/Active status. The corresponding LED indicator will light solid green when connected to a network device. It flashes green when data is being transmitted or received on the working connection.
- **1000Mbps LED:** The corresponding port LED indicator will light solid green when it's working on 1000Mbps speed. Not lit indicates working on 10/100Mbps speed.

2.2 Rear Panel

The rear panel of TL-SG1008 features a power socket and a Grounding Terminal (marked with )

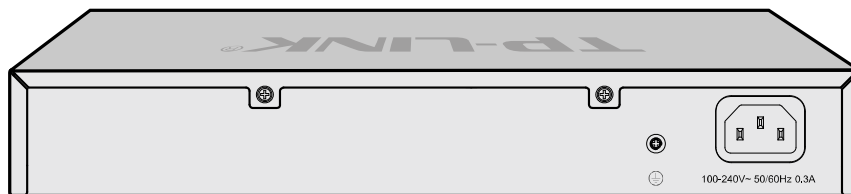

Figure 2-2 TL-SG1008 Switch Rear Panel sketch

- **Grounding Terminal:** TL-SG1008 already comes with Lightning Protection Mechanism. You can also ground the Switch through the PE (Protecting Earth)

cable of AC cord or with Ground Cable. For detail information, please refer to section **3.3 Connect to Ground**.

- **AC Power Socket:** Connect the female connector of the power cord here, and the male connector to the AC power outlet. Please make sure the voltage of the power supply meets the requirement of the input voltage.

Chapter 3 Installation

3.1 Precautions

To ensure a long-term and stable performance of the Switch, please pay attention to the following before the installation.

1) Safety Requirements

- Before cleaning the Switch, cut off the power supply. Do not clean it by the waterish cloth, and never use any other liquid cleaning method.
- Take waterproof measures during storage, transportation and operation of the equipment.
- Use only the power cord provided with the Switch.
- Make sure the voltage of the power supply meets the requirement of the input voltage of the Switch.
- Do not push any objects into the openings of the Switch.
- Ensure the vent hole is well ventilated and unblocked.
- Do not open or remove the cover of the Switch.

2) Location Requirements

When you choose a location for the Switch, please follow these guidelines:

- Install the Switch on a flat and stable surface that can support the entire weight of the Switch with all fittings.
- Locate the Switch far from strong electromagnetic field generators (such as motors), vibration, dust, and direct exposure to sunlight.
- To ensure adequate air flow around the Switch. At least 10 cm (4 inches) of space at the front and rear of the Switch is needed for ventilation.
- Make sure that the Switch will be accessible and that the cables can be easily connected.
- Position the Switch away from water and moisture sources, be sure to provide an acceptable temperature and humidity operating environment.

3.2 Installation

This Switch can be either installed on the standard 19-inch mountable rack or located on the desktop.



Caution:

Please unplug the power cord before installing or removing the Switch.

3.2.1 Desktop Installation

To install the Switch on the desktop, please follow the steps:

- 1) Set the Switch on a flat surface strong enough to support the entire weight of the Switch with all fittings.
- 2) Remove the adhesive backing papers from the rubber feet.
- 3) Turnover the Switch and attach the supplied rubber feet to the recessed areas on the bottom at each corner of the Switch.

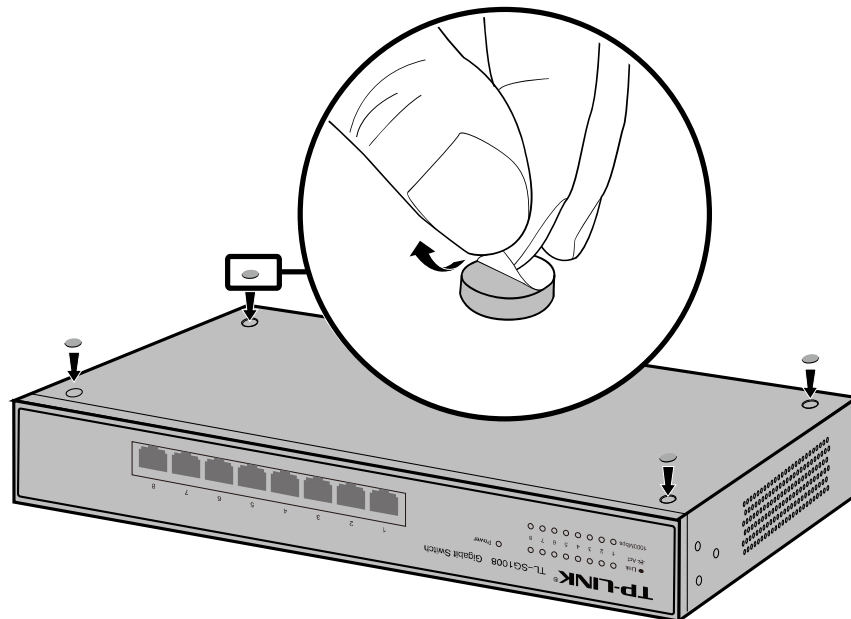

Figure 3-1 Attaching Rubber Feet

- 4) Upturn the Switch and connect it to the network devices while keep enough ventilation space around.
- 5) Connect the Switch to power source with the provided power cord.



Caution:

Please avoid any heavy thing placed on the Switch.

3.2.2 Rack Installation

To install the Switch in an EIA standard-sized, 19-inch rack, follow the instructions described below:

- 1) Secure the supplied rack-mounting brackets to each side of the Switch with supplied screws, as illustrated in the following figure.

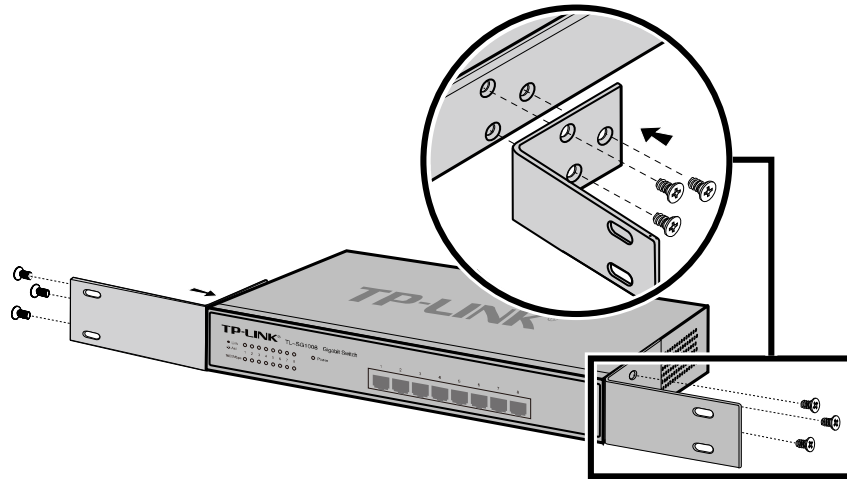

Figure 3-2 Attaching Brackets

- 2) After the brackets are attached to the Switch, use suitable screws (not provided) to secure the brackets to the rack, as illustrated in the following figure.

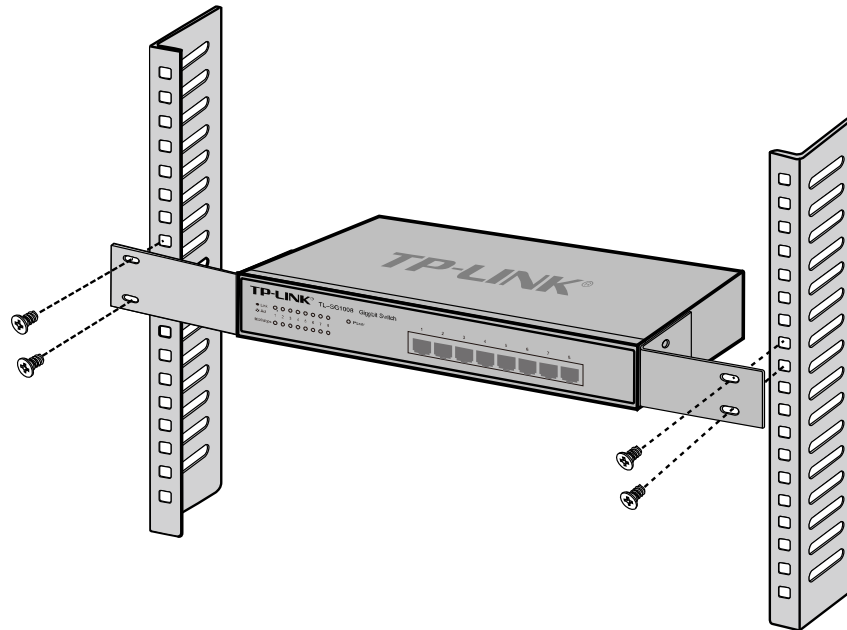

Figure 3-3 Mounting Switch

- 3) Connect the Switch to network devices.
- 4) Supply power to the Switch with the provided power cord.



Note:

TL-SG1016D and TL-SG1024D do not support rack installation.

3.3 Connect to Ground

Connecting the Switch to ground is to quickly release the lightning over-voltage and over-current of the Switch, which is also a necessary measure to protect the body from electric shock.

In different environments, the Switch may be grounded differently. The following will instruct you to connect the Switch to the ground in two ways, connecting to the Grounding Bar or connecting to the Ground via the power cord. Please connect the Switch to ground in the optimum way according to your specific operation environment.

- **Connecting to the Grounding Bar**

If the Switch is installed in the Equipment Room, where a Grounding Bar is available, you are recommended to connect the Switch to the Grounding Bar as shown in the following figure.

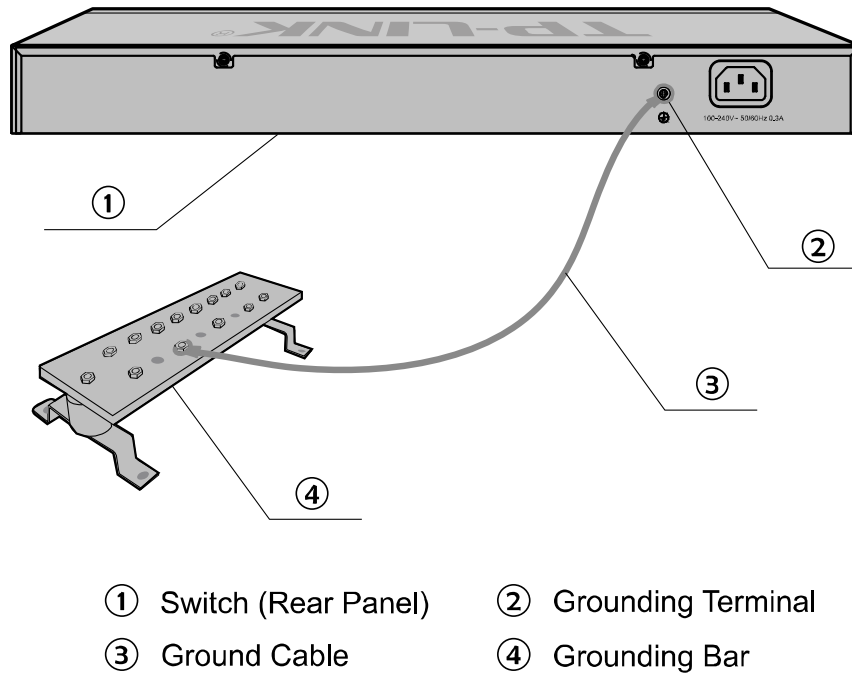

Figure 3-4



Note:

The Grounding Bar and Ground Cable is not provided with our product.

- **Connecting to the Ground via the power supply**

If the Switch is installed in the normal environment, the Switch can be grounded via the PE (Protecting Earth) cable of the AC power supply as shown in the following figure.

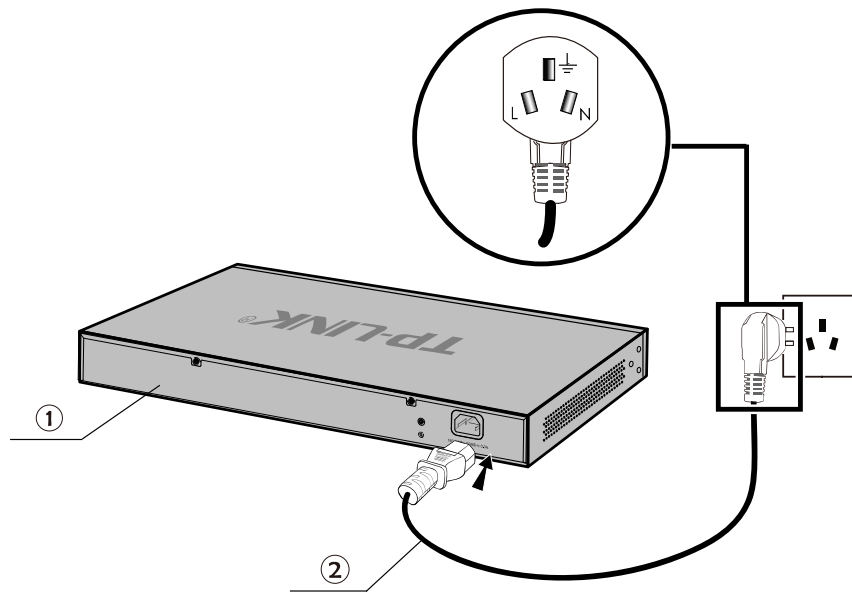

- ① Switch (Rear Panel) ② AC Power Cord (with PE cable)

Figure 3-5

* The figure is to illustrate the application and principle. The power plug you get from the package and the socket in your situation will comply with the regulation in your country, so they may differ from the figure above.



Note:

If you intend to connect the Switch to the ground via the PE (Protecting Earth) cable of AC power cord, please make sure the PE (Protecting Earth) cable in the electrical outlet is well grounded in advance.

3.4 Power on

The TL-SG1008/TL-SG1016D/TL-SG1024D Switch is powered by an AC Power Supply. Connect the Switch and power outlet by power cord. Powering on the Switch, it will be automatically initialized and the LED indicators should respond as follows:

- 1) All of the LED indicators will flash momentarily for one second, which represents a resetting of the system.
- 2) The Power LED indicator will light up.

Appendix A: Specifications

General	
Standards	IEEE802.3 10Base-T IEEE802.3u 100Base-TX IEEE802.3ab 1000Base-T
Topology	Star
Protocol	CSMA/CD
Data Transfer Rate	Ethernet: 10Mbps (Half Duplex), 20Mbps (Full Duplex)
	Fast Ethernet: 100Mbps (Half Duplex), 200Mbps (Full Duplex)
	Gigabit Ethernet: 2000Mbps (Full Duplex)
Network Media (Cable)	10Base-T: UTP category 3, 4, 5 cable (maximum 100m) EIA/TIA-568 100 STP (maximum 100m)
	100Base-TX: UTP category 5, 5e cable (maximum 100m) EIA/TIA-568 100 STP (maximum 100m)
	1000Base-T: UTP category 5, 5e cable (maximum 100m) EIA/TIA-568 100 STP (maximum 100m)
Number of Ports	8/16/24 10/100/1000Mbps Auto-Negotiation RJ-45 ports
LED indicators	POWER, Link/Act, 1000Mbps
Transfer Method	Store-and-Forward
MAC Address Learning	Automatically learning, automatically aging
Frame Filter Rate	10Base-T: 14881pps/Port
	100Base-Tx: 148810pps/Port
	1000Base-T: 1488095pps/Port
Frame Forward Rate	10Base-T: 14881pps/Port
	100Base-Tx: 148810pps/Port
	1000Base-T: 1488095pps/Port

Environmental and Physical	
Operating Temperature	0°C~40°C (32°F~104°F)
Storage Temperature	-40°C~70°C (-40°F~158°F)
Operating Humidity	10%~90% non-condensing
Storage Humidity	5%~90% non-condensing

Appendix B: Troubleshooting

1. The Power LED is not lit

- Make sure the AC power cord connected the Switch with power source properly.
- Make sure the power source is ON.

2. The Link/Act LED is not lit when a device is connected to the corresponding port

- Make sure that the cable connectors are firmly plugged into the Switch and the device.
- Make sure the connected device is turned on and working well.
- The cable must be less than 100 meters long(328 feet).

Appendix C: Contact Information

For help with the installation or operation of the TP-LINK TL-SG1008/TL-SG1016D/TL-SG1024D Switch, please contact us.

E-mail: [**support@tp-link.com**](mailto:support@tp-link.com)

Website: [**http://www.tp-link.com**](http://www.tp-link.com)



TP-LINK[®]
TP-LINK TECHNOLOGIES CO., LTD.
<http://www.tp-link.com>

