

Illumina DRAGEN Server

Installation Guide

Introduction	1
Racking the Server	2
Cabling	7
Installing USB License Key	7
BMC/iDRAC Configurations	8
Network Configuration	8
DNS Configuration	9
Set Server Time	9
External Storage	10
License Activation	11
Running the System Check	12
Shutting Down the Server	13
Advance Exchange	13
Revision History	17
Technical Assistance	19

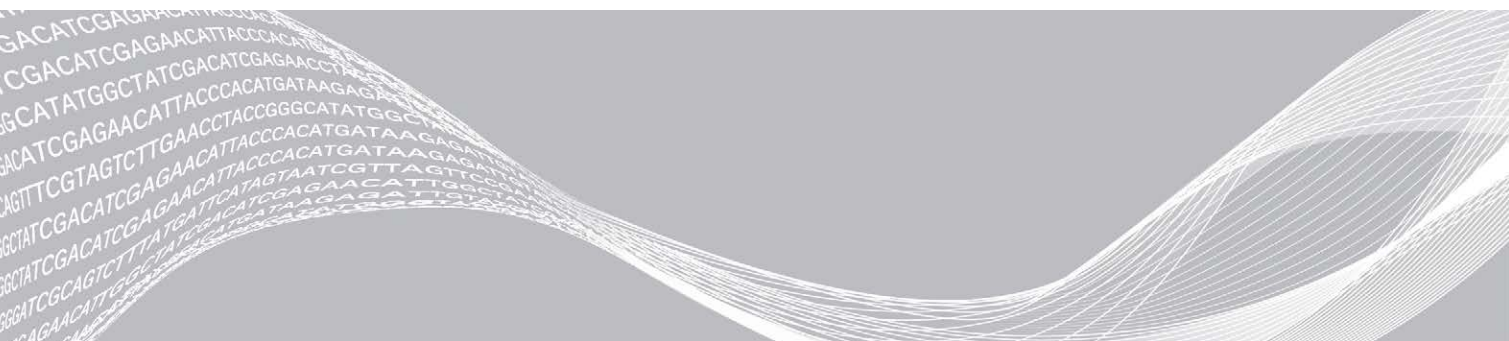

This document and its contents are proprietary to Illumina, Inc. and its affiliates ("Illumina"), and are intended solely for the contractual use of its customer in connection with the use of the product(s) described herein and for no other purpose. This document and its contents shall not be used or distributed for any other purpose and/or otherwise communicated, disclosed, or reproduced in any way whatsoever without the prior written consent of Illumina. Illumina does not convey any license under its patent, trademark, copyright, or common-law rights nor similar rights of any third parties by this document.

The instructions in this document must be strictly and explicitly followed by qualified and properly trained personnel in order to ensure the proper and safe use of the product(s) described herein. All of the contents of this document must be fully read and understood prior to using such product(s).

FAILURE TO COMPLETELY READ AND EXPLICITLY FOLLOW ALL OF THE INSTRUCTIONS CONTAINED HEREIN MAY RESULT IN DAMAGE TO THE PRODUCT(S), INJURY TO PERSONS, INCLUDING TO USERS OR OTHERS, AND DAMAGE TO OTHER PROPERTY, AND WILL VOID ANY WARRANTY APPLICABLE TO THE PRODUCT(S).

ILLUMINA DOES NOT ASSUME ANY LIABILITY ARISING OUT OF THE IMPROPER USE OF THE PRODUCT(S) DESCRIBED HEREIN (INCLUDING PARTS THEREOF OR SOFTWARE).

© 2019 Illumina, Inc. All rights reserved.

All trademarks are the property of Illumina, Inc. or their respective owners. For specific trademark information, see www.illumina.com/company/legal.html.

Introduction

The Illumina DRAGEN™ Server is preconfigured to be seamlessly integrated into bioinformatics workflows. IT runs the Bio-IT Platform, based on the highly reconfigurable DRAGEN Bio-IT Processor, which is integrated on a Field Programmable Gate Array (FPGA) card. The platform can be loaded with highly optimized algorithms for many different Next Generation Sequencing (NGS) secondary analysis pipelines, including the following:

- ▶ Whole genome
- ▶ Exome
- ▶ RNA-Seq
- ▶ Methylome
- ▶ Microbiome
- ▶ Cancer

All user interaction is accomplished via DRAGEN software that runs on the DRAGEN server and manages all communication with the DRAGEN board.

This user guide summarizes the technical aspects of the system, and provides detailed information for all DRAGEN command line options.

Before You Begin

The DRAGEN Server includes an Intel X710 DP 10 Gb DA/SFP+, +1350 DP 1 Gb Ethernet NIC. Illumina recommends that the DRAGEN Server is connected to an attached storage system with a 10 Gb link, using either copper or fiber cables. For fiber, transceivers might be necessary. As long as DRAGEN has a sustained IO of 400 Mb/sec, it can stream samples and write output files without any need to copy to/from NAS.

Refer to the [Terms & Conditions](#) for further information regarding acceptable use of the server and covered warranty.

Before installing your Illumina DRAGEN Server, make sure that you have received the following items in the box with the server:

- ▶ 10 GB SFP Optical Adapters (2)
- ▶ DRAGEN License USB Key
- ▶ Power Cables (2)
- ▶ Rack rails (2)

Also required for installation (not included):

- ▶ 10 GB copper (or fiber) cable for network connection to your DRAGEN Server
- ▶ RJ45 Cat5 (or better) for network connection to the iDRAC

[Optional] accessories for installation (not included):

- ▶ Monitor
- ▶ Keyboard
- ▶ Mouse

Hardware Specifications

Table 1 DRAGEN Server Hardware Specifications

Component	Specification
Processor	Dual Intel Xeon Gold 6126 2.6 G, 12 C/24 T
Memory	256 GB
Scratch drive	2 TB Intel NVME P4600
OS drives	2x120 GB SSD in Raid 1
FPGA card	DRAGEN
Remote access	iDRAC8 Enterprise, integrated Dell Remote Access Controller, Enterprise
Operating system	CentOS 7.5
Networking	Intel X710 DP 10GB DA?SFP+, +1350 DP 1GB Ethernet
Form factor	2U rack
Dimensions	H 8.73 cm (3.44 in), W 44.4 cm (17.49 in), D 68.4 cm (26.92 in)
Power supply	Dual, hot-plug, redundant power supply (1 + 1), 1100 W

Racking the Server



NOTE

Install sliding rails onto rack so the sliding rails extend forward.

- 1 Attach the first sliding rail to the back of rack by attaching the bracket (at the rear of the sliding rail) to the rack.

Figure 1 Server Rack and Sliding Rail

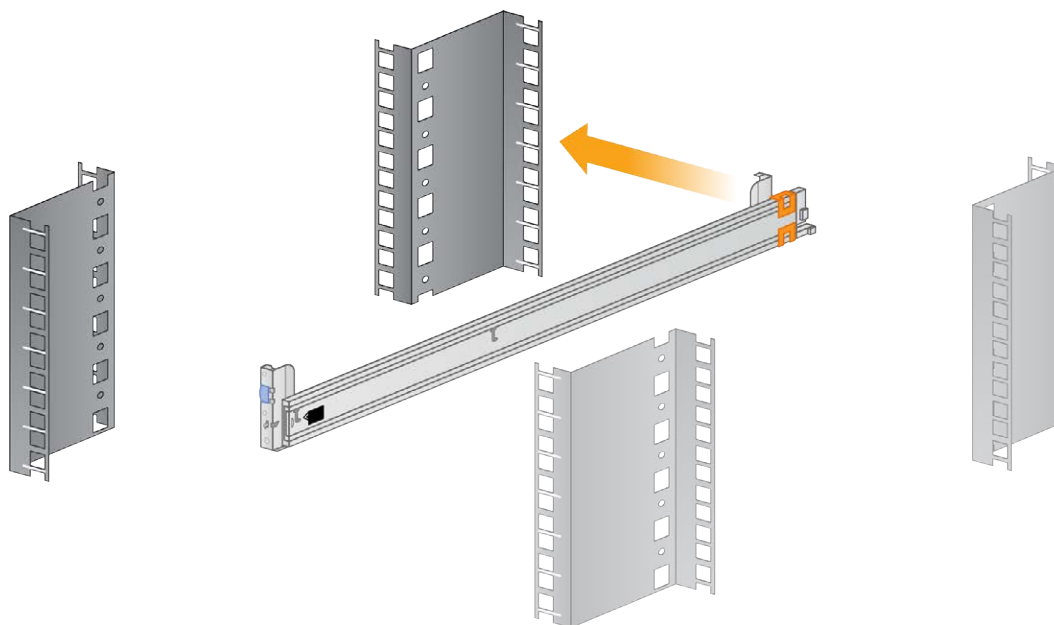

- 2 Pull the entire sliding rail past the front of the rack and snap it back into place.

Figure 2 Sliding Rail Snapped onto Server Rack

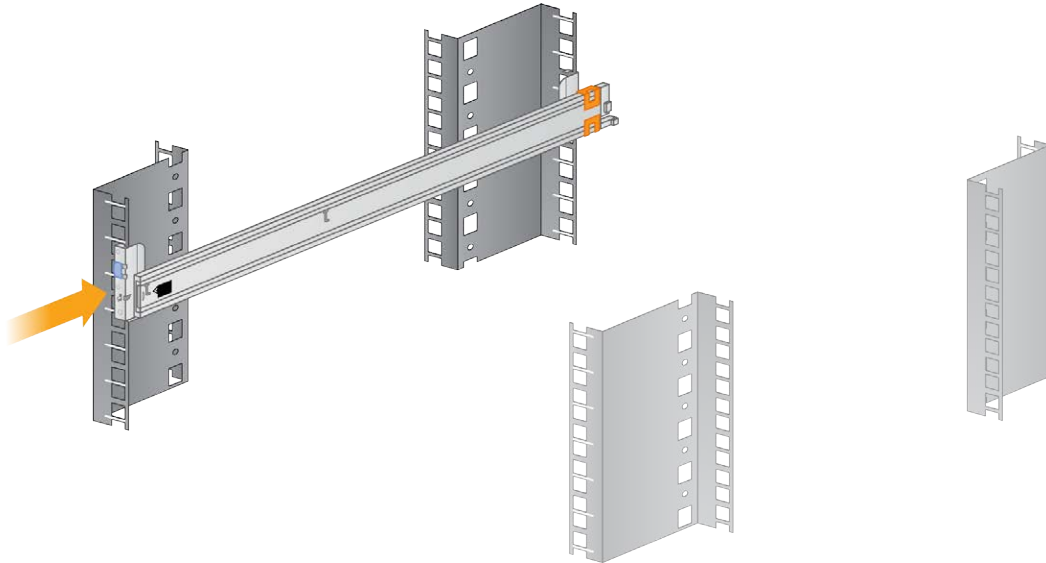

- 3 Install the second rail at the same level on the other side of the rack.

Figure 3 Server Rack and Both Sliding Rails

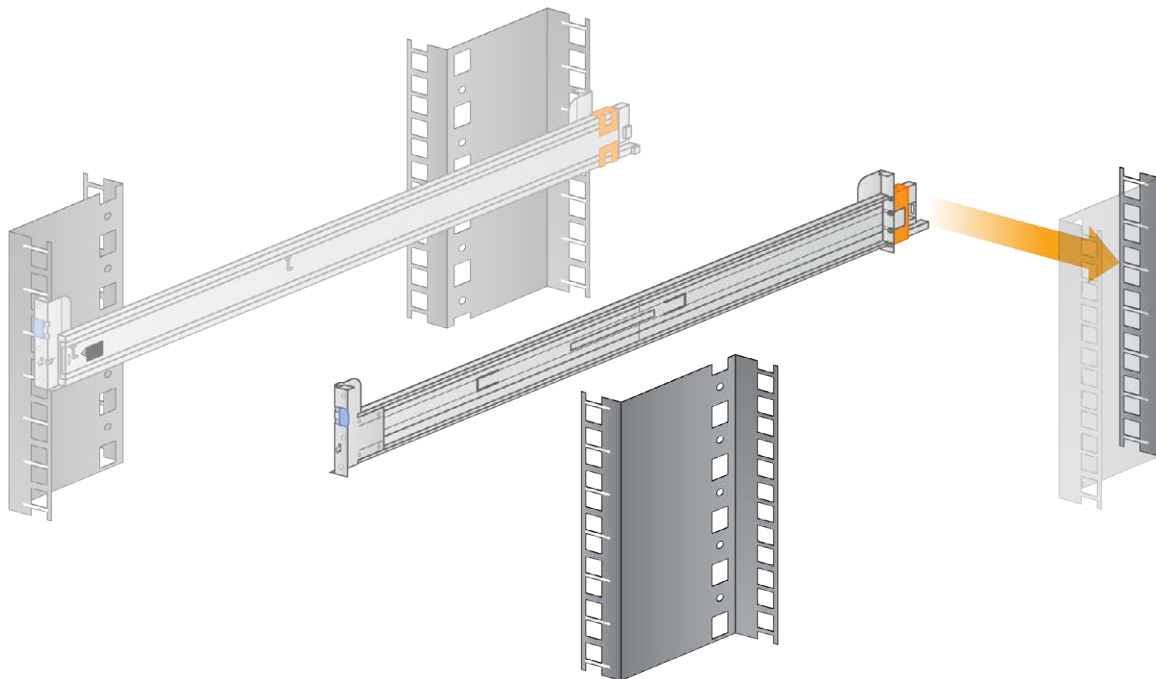

- 4 Extend the sliding rails completely.

Figure 4 DRAGEN Server, Sliding Rails (Extended) and Server Rack

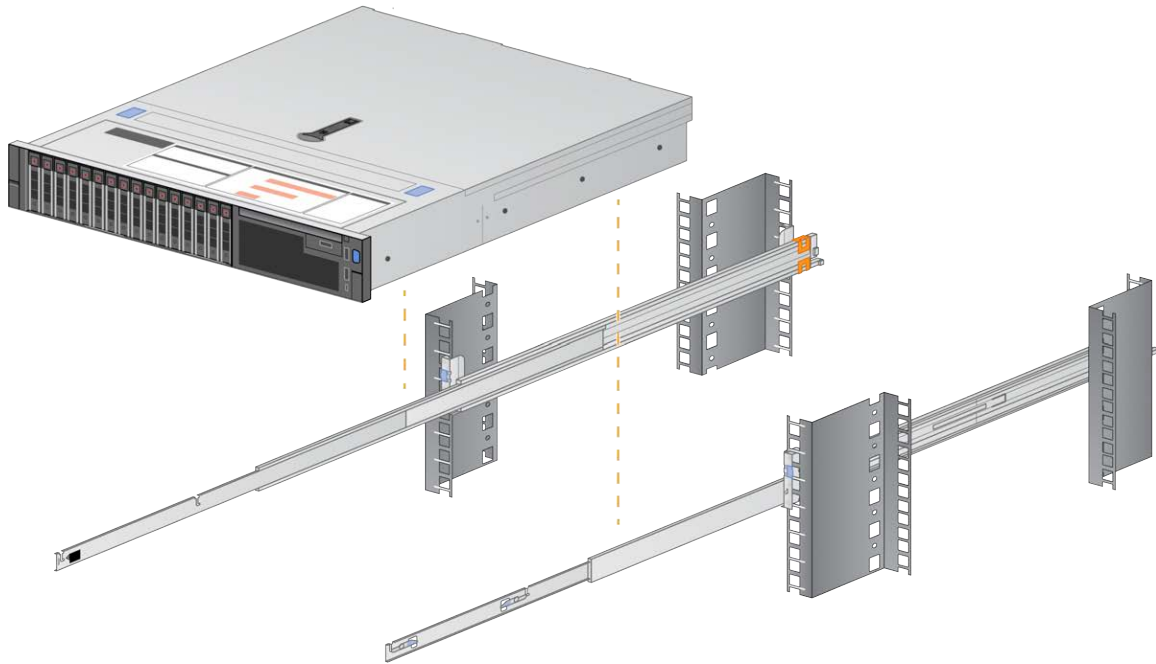

- 5 Facing the front of the rack, use two people (one on either side) to lift the server in between the two extended rails, with the front of the server facing out.

Figure 5 DRAGEN Server Lowered Between Extended Sliding Rails

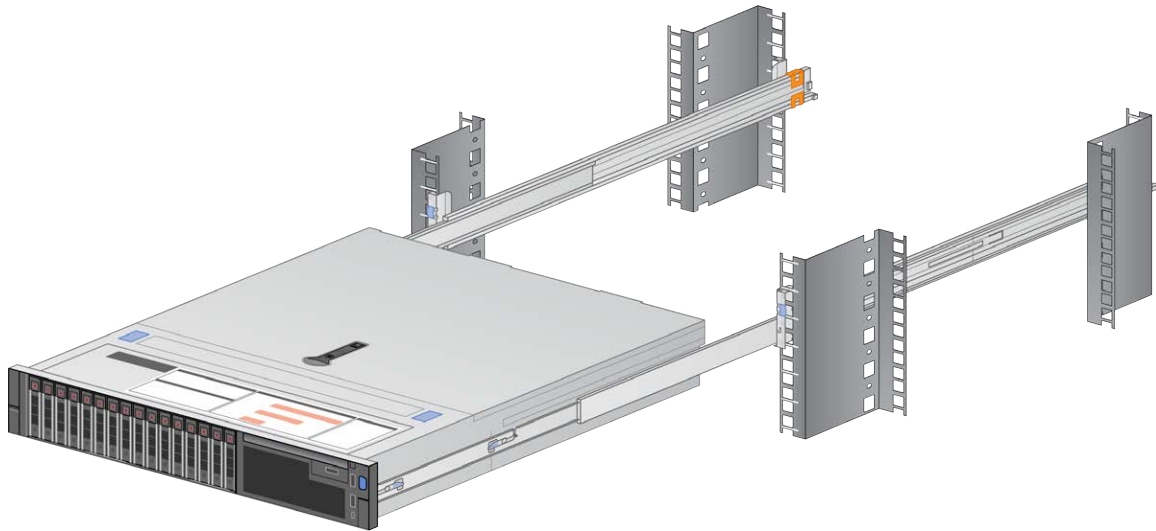

- 6 Locate the eight flat black screws on the server (four on either side).
- 7 Line up the eight black flat screws with the corresponding notches in the sliding rails.
- 8 Attach the rear of the server onto the rails first, and then snap all eight into place.

- 9 Make sure that all eight screws are fully seated and locked.

Figure 6 Black Flat Screw Seated in Notch



Figure 7 Flat Black Screw in Notch - Unlocked

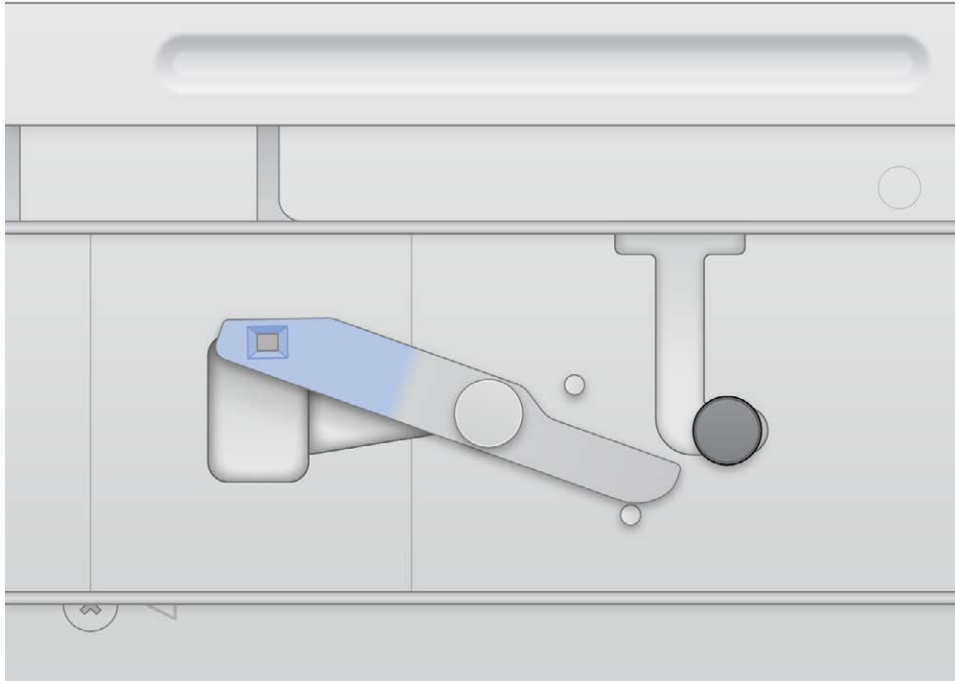
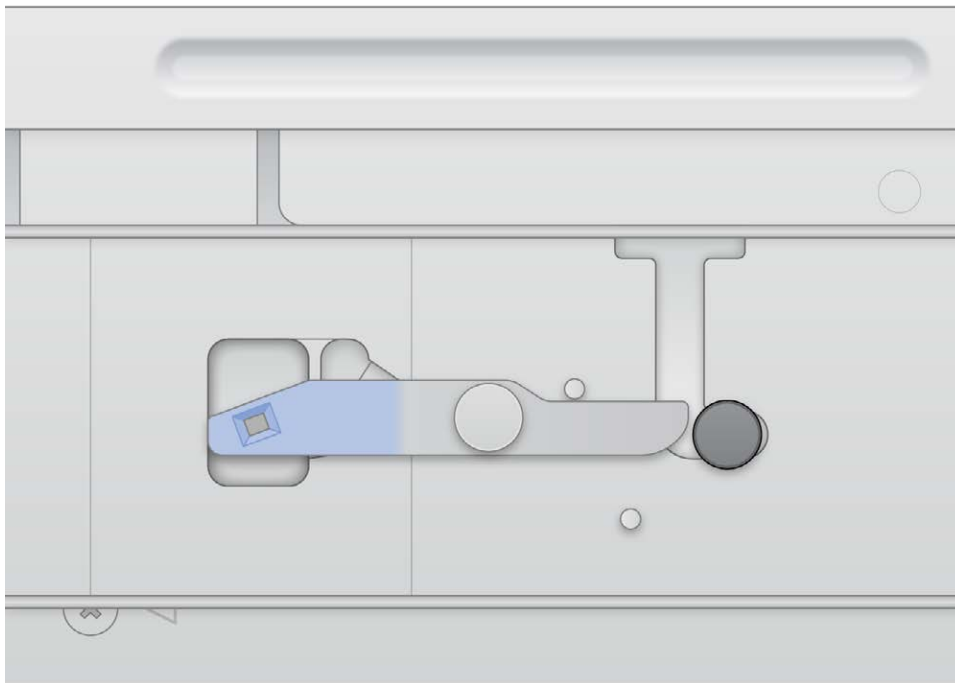
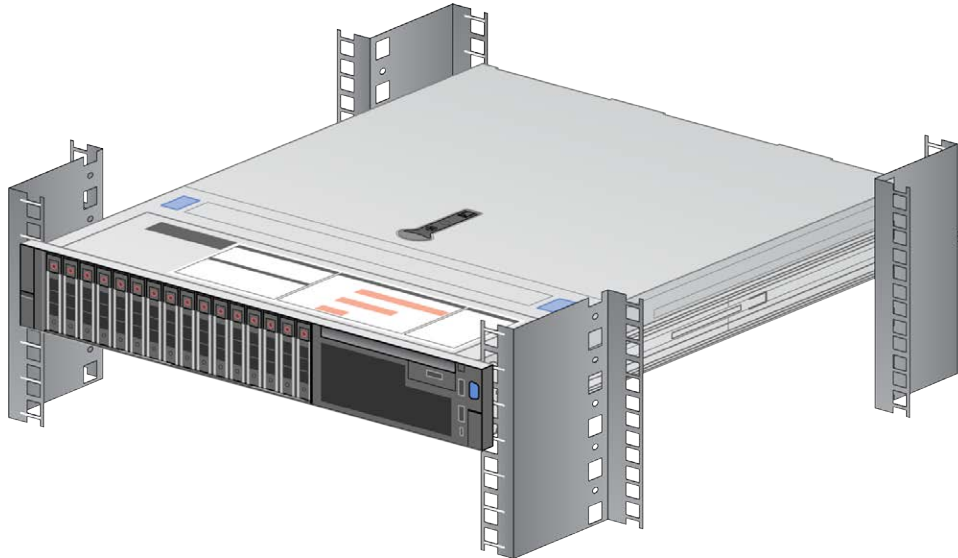

Figure 8 Flat Black Screw in Notch - Locked



10 Slide the server back onto the rack.

Figure 9 DRAGEN Server Installed on Server Rack



Cabling

Figure 10 Rear of DRAGEN Server

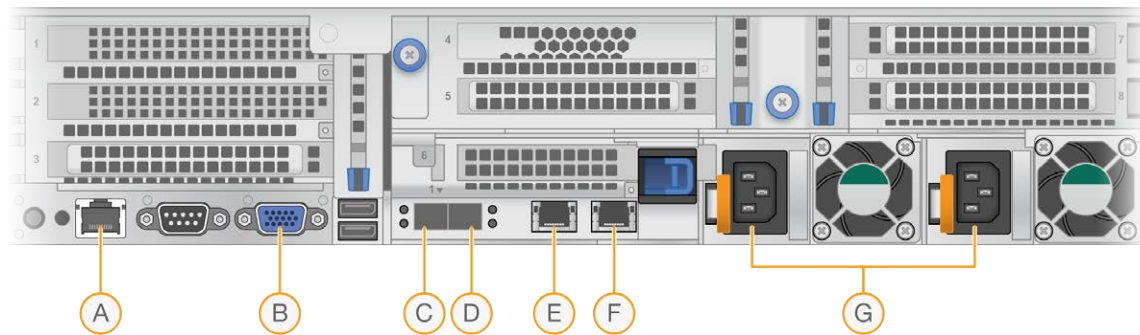

- A iDRAC
- B Monitor
- C 10 GB SFP Port 1
- D 10 GB SFP Port 2
- E RJ45 1 GB Port 1
- F RJ45 1 GB Port 2
- G Power Supply (2)

Installing USB License Key

- 1 Locate the USB license key in the delivery box.
- 2 Plug the USB license key into any USB port on the back of the server.

- 3 Turn on the server.

**NOTE**

The USB key must remain plugged into the server at all times.

BMC/iDRAC Configurations

- 1 Connect a monitor, keyboard, and mouse (optional) to the server.
- 2 Connect an Ethernet cable (RJ45) to the BMC/iDRAC network port at the back of the server.
- 3 Turn on the system. The DRAGEN splash page appears on the monitor.
- 4 Press **F2** to enter BIOS.
- 5 Under **iDRAC Settings Network**, scroll down to **IPV4 Settings**
- 6 Under **IPV4 Settings**, do the following:
 - ▶ Disable DHCP.
 - ▶ Enter IP address.
 - ▶ Enter gateway.
 - ▶ Enter subnet mask.
 - ▶ Select **Back**.
- 7 Select **Finish**. A prompt to save changes appears.
- 8 After changes have been saved, the prompt reads Success.
- 9 At the main window, select **Exit** in the top right corner.
- 10 Confirm that you want to exit to reboot the server.

Network Configuration

- 1 After the server has rebooted, log in using the credentials provided to you by your Illumina customer service representative. If you have not received login credentials, contact customerservice@illumina.com.
- 2 Change the root password before continuing with any configuration. Enter:

```
passwd
```
- 3 Enter:

```
cd /etc/sysconfig/network-scripts/
```
- 4 Several files appear. Locate filename:

```
ifcfg-eth0
```
- 5 Edit the file using vi, enter:

```
vi ifcfg-eth0
```
- 6 Enter the following information. Enter "static" for bootproto and refer to the pre-installation form (or contact your IT department) for the ip address, netmask and gateway:

```
BOOTPROTO="static"
IPADDR=
NETMASK=
GATEWAY=
```

- 7 Save the file, enter:
`:wq!`
- 8 Enter `systemctl restart network` to restart network to apply the changes.
- 9 After restarting the network service, verify the IP address.

DNS Configuration

- 1 Log in as root.
- 2 Add the DNS server by editing `/etc/resolv.conf` using `vi`, enter:
`vi/etc/resolv.conf`
- 3 Enter the DNS server IP address provided by customer IT.
Example:
`nameserver 192.168.1.1`
`nameserver 192.168.1.2`
- 4 Save the file, enter:
`:wq!`
- 5 Restart the network to apply changes using this command:
`systemctl restart network`
- 6 Ping an external URL site to make sure that name resolution is working.
Example:
`ping www.illumina.com`

Set Server Time

Set Server Time to Local Time Zone

- 1 Log in as root.
- 2 Check if the current server time reflects the local time zone using the `date` command. Enter:
`date`
- 3 Using the `timedatectl` command, check for a nearby city with the correct time zone.
For example, searching time zones in Asia:
`timedatectl list-timezones | grep Asia`
- 4 Change the server time to local time.
Example:
`timedatectl set-timezone Asia/Singapore`
- 5 Make sure that the server time has changed using the `date` command. Enter:
`date`
`ls -l /etc/localtime`

Synchronize Server Time to NTP Server

- 1 Log in as root.
- 2 Check if ntp daemon is running, enter:

```
systemctl enable ntpd
```
- 3 If the result from the previous command shows inactive or dead, enable the ntp daemon, enter:

```
systemctl enable ntpd
```
- 4 Start the daemon, enter:

```
systemctl start ntpd
```
- 5 Edit /etc/ntp using vi, enter:

```
vi /etc/ntp.conf
```
- 6 Replace the default NTP server settings to the local NTP server.
 Example:

```
<original default settings>
server 0.centos.pool.ntp.org iburst
server 1.centos.pool.ntp.org iburst
server 2.centos.pool.ntp.org iburst
server 3.centos.pool.ntp.org iburst
<settings to use local NTP server/s>
server 192.168.1.1 iburst
server 192.168.1.2 iburst
```
- 7 Save the file, enter:

```
:wq!
```
- 8 Restart the ntp daemon, enter:

```
systemctl restart ntpd
```
- 9 Check the health of the local to me server, enter:

```
ntpq -p
```
- 10 Make sure that Dragen can synchronize with the local NTP server using the ntpdate command.
 Example:

```
ntpdate -q 192.168.1.1
```

External Storage

Mounting NFS on DRAGEN Server

- 1 Locate your NFS Server and share name.
 Example:
 - ▶ Server: 192.168.100.100
 - ▶ Share name: /share
- 2 This example would be 192.168.100.100:/share.

- 3 To map this share to `/mnt` on the DRAGEN server, run the following command as root on your system:

```
mount -t nfs 192.168.100.100:/share /mnt
```
- 4 Share is mounted at `192.168.100.100:/share` to the local file system under `/mnt`.

Mounting SMB/CIFS on DRAGEN Server

- 1 Locate your SMB/CIFS server and share name.
 Example:
 - ▶ Server: `192.168.100.100`
 - ▶ Share name: `/share`
- 2 Locate the username and password required to access this share (if applicable).
 Example:
 - ▶ Username: `sbsuser`
 - ▶ Password: `sbs123`
- 3 This example would be `//192.168.100.100/share`.
- 4 To map this share to `/mnt` on the DRAGEN server, run the following command as root on your local system:

```
mount -t cifs -o user=sbsuser //192.168.100.100/share /mnt
```
- 5 Enter password when prompted.
- 6 Share is mounted at `//192.168.100.100/share` to the local file system under `/mnt`.

Adding NFS or SMB mount to `/etc/fstab`

- 1 Add the network share to `/etc/fstab` so that the mount is permanent across reboots. Using the previous examples in [Mounting NFS on DRAGEN Server on page 10](#) and [Mounting SMB/CIFS on DRAGEN Server on page 11](#), this is what a basic entry in your `/etc/fstab` would look for a NFS or SMB mount:
 NFS:

```
192.168.100.100:/share /mnt nfs rsize=8192,wsize=8192 0 0
```

 SMB:

```
//192.168.100.100/share /mnt cifs user=sbsuser,pass=sbs123 0 0
```

License Activation

The DRAGEN server ships with temporary short-term licenses. The license activation process differs depending on whether the server is connected to the internet or is offline. Root/sudo access is needed to run the commands below. For assistance with the various command line options, contact Technical Support at techsupport@illumina.com. Follow the instructions below to activate your licenses.

Online Servers

For servers connected to the internet, license information can be activated as follows.

- 1 Test and confirm that the server is connected to the internet.
 Example:
 - ▶ Ping `www.illumina.com`

- 2 To activate the license, enter:

```
/opt/edico/bin/dragen_lic -i auto
```

- 3 Confirm that the license has been updated. Enter:

```
/opt/edico/bin/dragen_lic
```

Offline Servers

For offline servers not connected to the internet, Illumina Customer Service provides the necessary license files to activate the license on the server locally. If you have not received these license files, contact customerservice@illumina.com.

After you have the necessary license files, activate the license as follows.

- 1 Copy the license files to the server.

- 2 Run the following commands:

```
sudo rm /var/lib/edico/*.gbin
sudo /opt/edico/bin/dragen_lic -i license_genome.bin
sudo /opt/edico/bin/dragen_lic -i license_somatic.bin
sudo /opt/edico/bin/dragen_lic -i license_cnv.bin
sudo /opt/edico/bin/dragen_lic -P license.dat
```

- 3 Confirm that the license has been updated. Enter:

```
/opt/edico/bin/dragen_lic
```

Running the System Check

After turning on the server, you can make sure that your DRAGEN server is functioning properly by running `/opt/edico/self_test/self_test.sh`, which does the following:

- ▶ Automatically indexes chromosome M from the hg19 reference genome
- ▶ Loads the reference genome and index
- ▶ Maps and aligns a set of reads
- ▶ Saves the aligned reads in a BAM file
- ▶ Asserts that the alignments exactly match the expected results

Each server ships with the test input FASTQ data for this script, which is located in `/opt/edico/self_test`. The system check takes approximately 25–30 minutes.

The following example shows how to run the script and shows the output from a successful test.

```
[root@edico2 ~]# /opt/edico/self_test/self_test.sh
-----
test hash creating
test hash created
-----
reference loading /opt/edico/self_test/ref_data/chrM/hg19_chrM
reference loaded
-----

real0m0.640s
user0m0.047s
```

```

sys0m0.604s
not properly paired and unmapped input records percentages: PASS
-----
md5sum check dbam sorted: PASS
-----
SELF TEST COMPLETED
SELF TEST RESULT : PASS

```

If the output BAM file does not match expected results, then the last line of the above text is as follows:

```
SELF TEST RESULT : FAIL
```

If you experience a FAIL result after running this test script immediately after turning on your DRAGEN server, contact Illumina Technical Support.

Shutting Down the Server

Shutdown DRAGEN Server From Command Line

- 1 Log in as root.
- 2 To initiate system shutdown, enter:
`poweroff`
- 3 Wait a few minutes until the server comes to a complete shutdown.

Shutdown DRAGEN Server From iDRAC Web Console

- 1 Open a browser and log in to the iDRAC web console by typing `https://<ip-address>`.
For example: `https://192.168.1.101`



NOTE

This iDRAC IP address is configured during installation based on network settings information provided by customer IT support. The default login account for iDRAC is **root** and the default password is **calvin**. The password can be changed during the installation process. For more information, see [BMC/iDRAC Configurations on page 8](#).

- 2 From the right side of the Dashboard, select **Launch Virtual Console**.
- 3 Select **Power**.
- 4 Select **Graceful Shutdown** to initiate server shutdown.
- 5 Wait a few minutes until the server comes to a complete shutdown. The monitor displays **No Signal** when the server is successfully shut down.

Advance Exchange

Service Model

The DRAGEN server is serviced using the Illumina Advance Exchange replacement model where damaged or defective DRAGEN servers still under warranty are exchanged with a replacement server. To check the warranty status of your current server, contact customer service at customerservice@illumina.com.

Illumina support performs troubleshooting to determine whether a server needs to be exchanged. We recommend you contact techsupport@illumina.com as soon as you notice an issue with your system. Once the system has been determined to be damaged or defective, Illumina ships out a replacement server before the original is shipped back. This is done to minimize the downtime customer experience with their system. The actual time it takes to ship the replacement can vary by region.

Regional Applicability

Advance Exchange is available in all regions.

Receive a Replacement System

- 1 After a system check and other troubleshooting efforts have failed, contact Illumina Technical Support.
 - ▶ Make system check results available to Technical Support.
- 2 If Technical Support cannot resolve the issue remotely, a return is initiated and an order is placed for a replacement system.
- 3 When you receive the replacement server:
 - ▶ **Save all the packaging**, which is used to package the original server for return.
 - ▶ Set aside the return documents, which include a UPS return label and commercial invoice (for international shipments).
 - ▶ Verify receipt and condition of the server.

Prepare the Original Server for Return

Return the original server to Illumina within 30 days of receiving the replacement.

Shut Down and Disconnect

If the system is on, follow steps 1–3 to save and clear data before safely shutting down the server. Follow the remaining steps to disconnect cords and cables.

- 1 Back up all your data.
- 2 Delete any files and folders you do not want to share with Illumina.
- 3 Make sure that the server is not being used before shutting down the server.
For shutdown instructions, see [Shutting Down the Server on page 13](#).
- 4 Disconnect all power and Ethernet network cords from the back of the server.
- 5 If applicable:
 - ▶ Disconnect monitor, keyboard, mouse, and cables from the server.
 - ▶ Remove hard drives.



NOTE

Customers can retain hard drives at their discretion. However, hard drives cannot be installed in the replacement server. Doing so results in nonfunctionality. Hard drive retention is intended to comply with customer information security or data retention policies and standards.

- 6 Uninstall server from the rack.

Return the Original Server

Package the Server

- 1 Clear adequate space in the lab for the server and packaging.
- 2 Place the protective foam cover over the server.
- 3 Place the foam pad at the bottom of the box.
- 4 Place the original server into the box so that the top of the server faces up.

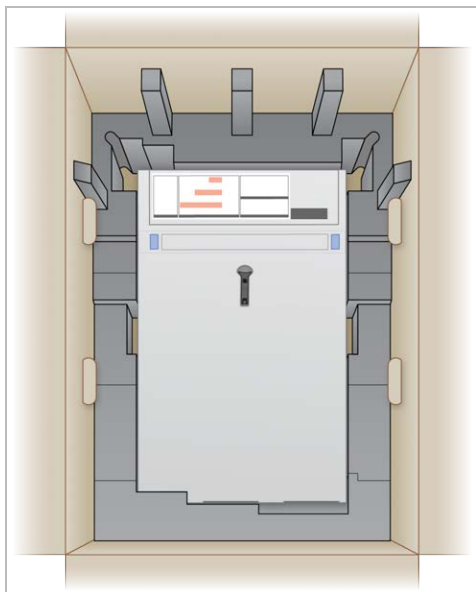

- 5 Place the foam cover on top of the server.

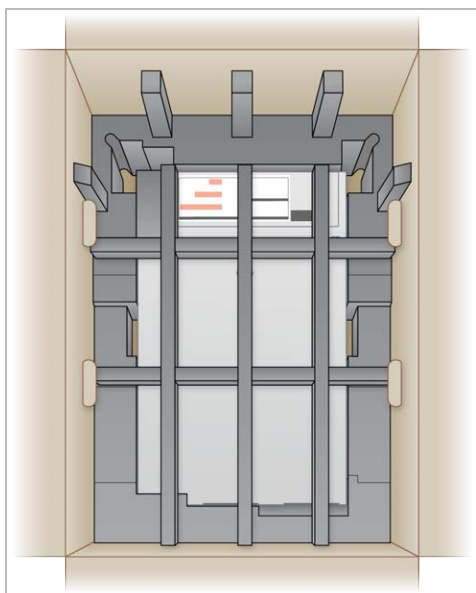

- 6 If necessary, place the accessories box into the center of the foam cover.
- 7 **[Optional]** Place the Ethernet cable and power cord anywhere in the box.

- 8 Make sure that the foam is flush with the top of the box.
- 9 Close the top of the box.



Ship the Server

- 1 Secure the box with shipping tape.
- 2 Remove the original shipping label and attach the provided return label to the box. Alternatively, place the return shipping label over the original shipping label.

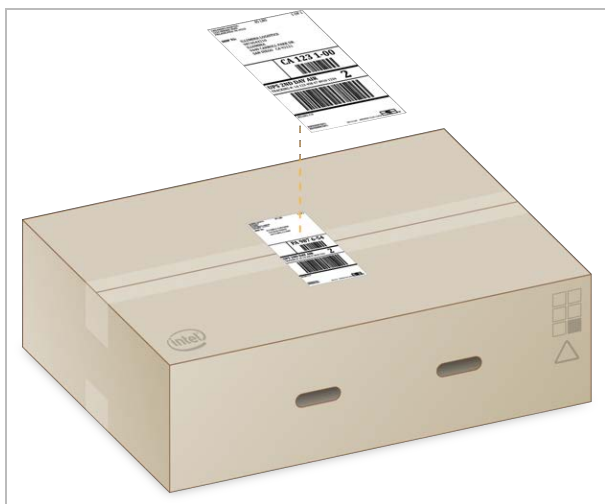

- 3 If shipping international, affix the commercial invoice to the shipping box.
- 4 Ship the instrument to Illumina via UPS.
 - ▶ If your facility has daily deliveries scheduled with UPS, give the labeled shipping box to the driver.
 - ▶ If your facility does not have daily deliveries with UPS, notify Illumina Customer Service so that they can schedule the return shipment for you.



NOTE

Lift the box by the handles. A two-person lift is recommended.

Revision History

Document	Date	Description of Change
Document # 1000000075000 v01	September 2019	Added Advanced Exchange instructions. Added shutdown instructions. Added DNS configuration information. Added BMC configuration information. Added information about changing system time settings. Added network card information.
Document # 1000000075000 v00	January 2019	Initial release.

Technical Assistance

For technical assistance, contact Illumina Technical Support.

Website: www.illumina.com
 Email: techsupport@illumina.com

Illumina Customer Support Telephone Numbers

Region	Toll Free	Regional
North America	+1.800.809.4566	
Australia	+1.800.775.688	
Austria	+43 800006249	+43 19286540
Belgium	+32 80077160	+32 34002973
China	400.066.5835	
Denmark	+45 80820183	+45 89871156
Finland	+358 800918363	+358 974790110
France	+33 805102193	+33 170770446
Germany	+49 8001014940	+49 8938035677
Hong Kong, China	800960230	
Ireland	+353 1800936608	+353 016950506
Italy	+39 800985513	+39 236003759
Japan	0800.111.5011	
Netherlands	+31 8000222493	+31 207132960
New Zealand	0800.451.650	
Norway	+47 800 16836	+47 21939693
Singapore	+1.800.579.2745	
South Korea	+82 80 234 5300	
Spain	+34 911899417	+34 800300143
Sweden	+46 850619671	+46 200883979
Switzerland	+41 565800000	+41 800200442
Taiwan, China	00806651752	
United Kingdom	+44 8000126019	+44 2073057197
Other countries	+44.1799.534000	

Safety data sheets (SDSs)—Available on the Illumina website at support.illumina.com/sds.html.

Product documentation—Available for download from support.illumina.com.



Illumina
5200 Illumina Way
San Diego, California 92122 U.S.A.
+1.800.809.ILMN (4566)
+1.858.202.4566 (outside North America)
techsupport@illumina.com
www.illumina.com

For Research Use Only. Not for use in diagnostic procedures.

© 2019 Illumina, Inc. All rights reserved.

illumina[®]