

COMe-m4AL10 (E2)

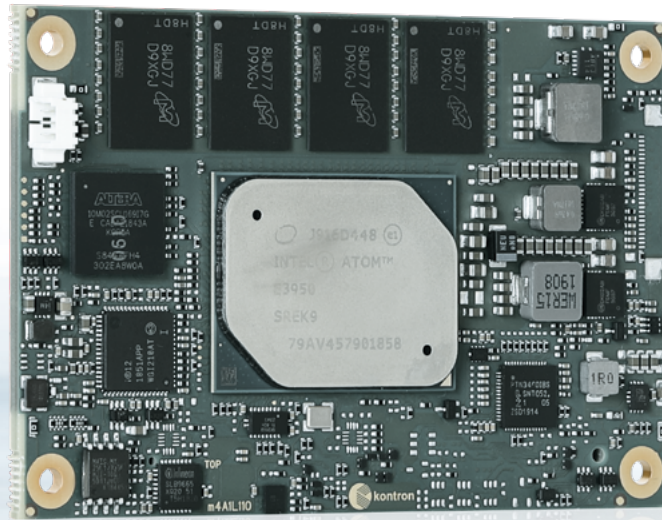

COM Express® mini Type 10 with Intel Atom® E3900 Series, Pentium® and Celeron® Processors

- ▶ Low-Power - Performance/Watt optimized small form factor solution
- ▶ Up to 16 GByte LPDDR4 memory down (non ECC)
- ▶ 2x USB 3.0/2.0, 6x USB 2.0, USB client optional, 2x SATA, eMMC Flash
- ▶ Industrial grade temperature

POSSIBILITIES START HERE



► TECHNICAL INFORMATION

COMPLIANCE	COM Express® mini, Pin-out Type 10
DIMENSIONS (H x W)	84 x 55 mm
CPU	Intel Atom® E3900 Series, Pentium® and Celeron® Processor For details see table (CPU variants) given below
CHIPSET	-
MAIN MEMORY	Up to 16 GByte LPDDR4-2400 memory down (non-ECC)
GRAPHICS CONTROLLER	Intel® HD Gfx Gen9: LVDS/eDP, 1x DP++, up to 4K
ETHERNET CONTROLLER	Intel® I210IT/I211AT
ETHERNET	10/100/1000 MBit Ethernet
STORAGE	2x SATA 6 Gb/s, SDIO Interface (shared with GPIO)
FLASH ONBOARD	depending on version
PCI EXPRESS®	PCIe lane configurations: 3 x1 / 2 x1 + 1 x2 / 2 x2
DISPLAY	DDI: DP++, LVDS: Single Channel 18/24 bit or eDP
USB	2x USB 3.0 (incl. USB 2.0) + 6x USB 2.0, Port 7 is dual role (Client/Host)
SERIAL	2x serial interface (RX / TX only)
AUDIO	Intel® High Definition Audio
COMMON FEATURES	SPI, LPC, SMB, Fast I ² C, Staged Watchdog, RTC
BIOS	AMI Aptio V
HUMIDITY	93% relative Humidity at 40 °C, non-condensing (according to IEC 60068-2-78)
FEATURES ON REQUEST	w/o onboard LAN: PCIe lane configuration 4 x1, eMMC Flash onboard (up to 64 GByte pSLC, up to 128 GByte MLC), eDP instead of LVDS, General Purpose SPI instead of Boot SPI, USB client, Security Chip (Support of Kontron APPROTECT),
POWER MANAGEMENT	ACPI 4.0
POWER SUPPLY	4.75 V – 20 V Wide Range, Single Supply Power
SPECIAL FEATURES	Trusted Platform Module TPM 2.0, 4k Resolutions, GPIO/SDIO Switch, General Purpose SPI optional, Industrial Temperature Grade versions
OPERATING SYSTEM	Windows® 10, Enterprise, Windows 10 IoT, Linux, VxWorks
TEMPERATURE	COMe-m4AL10: Commercial temperature: 0 °C to +60 °C operating, -30 °C to +85 °C non-operating COMe-m4AL10 E2: Industrial temperature: -40 °C to +85 °C operating, -40 °C to +85 °C non-operating

CPU VARIANTS

BRAND	PROCESSOR NUMBER	TDP	CORES	THREADS	CACHE	BASE FREQ	MAX TURBO FREQ	GRAPHICS GEN 11	ECC	USE CONDITION
Celeron®	N3350E	6 W	2	2	2 MByte	1.1 GHz	2.4 GHz	12	no	PC Client
Pentium®	N4200E	6 W	4	4	2 MByte	1.1 GHz	2.5 GHz	18	no	PC Client
Intel Atom®	x5-E3930	6.5 W	2	2	2 MByte	1.3 GHz	1.8 GHz	12	yes	Embedded
Intel Atom®	x5-E3940	9.5 W	4	4	2 MByte	1.6 GHz	1.8 GHz	12	yes	Embedded
Intel Atom®	x7-E3950	12 W	4	4	2 MByte	1.6 GHz	2.0 GHz	18	yes	Embedded

BLOCK DIAGRAM

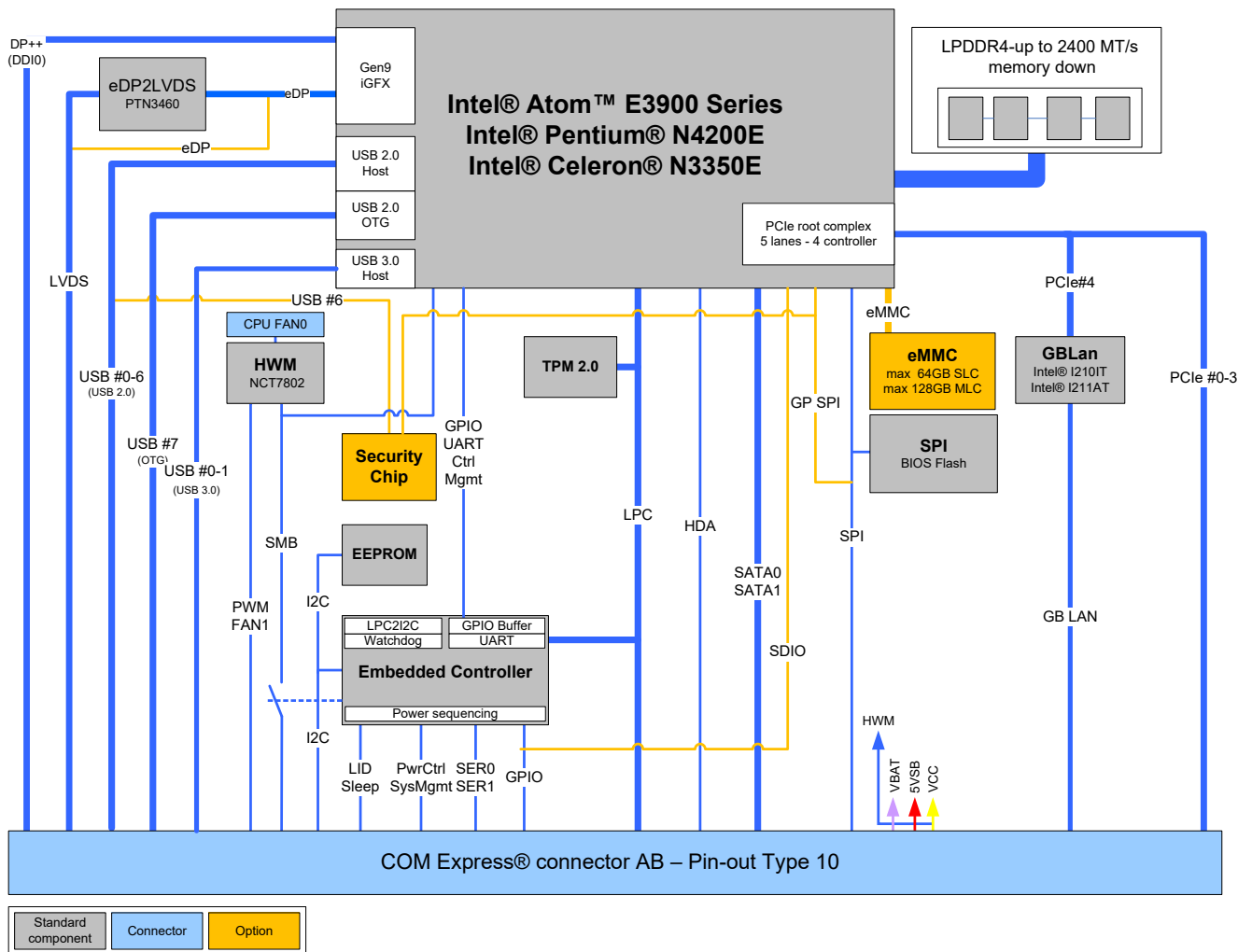

▶ VARIANTS

PART NO.	CPU	MEMORY	MEM-FREQ.	ETHERNET	FLASH - eMMC	VARIOUS	OP. TEMPERATURE
34010-0204-11-2	N3350	4 GByte	LPDDR4-2133	I211-AT	4 GByte pSLC	LVDS, no SecurityChip	0 °C - 60 °C
34010-0416-11-4	N4200	4 GByte	LPDDR4-2400	I211-AT	16 GByte pSLC	LVDS, no SecurityChip	0 °C - 60 °C
34011-0200-13-5	E3930	2 GByte	LPDDR4-2133	I210-IT	-	LVDS, no SecurityChip	-40 °C - 85 °C
34011-0408-13-5	E3930	4 GByte	LPDDR4-2133	I210-IT	8 GByte pSLC	LVDS, no SecurityChip	-40 °C - 85 °C
34011-0400-16-5	E3940	4 GByte	LPDDR4-2133	I210-IT	-	LVDS, no SecurityChip	-40 °C - 85 °C
34011-0416-16-5	E3940	4 GByte	LPDDR4-2133	I210-IT	16 GByte pSLC	LVDS, no SecurityChip	-40 °C - 85 °C
34011-0800-16-7	E3950	8 GByte	LPDDR4-2400	I210-IT	-	LVDS, no SecurityChip	-40 °C - 85 °C
34011-0832-16-7	E3950	8 GByte	LPDDR4-2400	I210-IT	32 GByte pSLC	LVDS, no SecurityChip	-40 °C - 85 °C

Please contact your sales representative for other versions.

▶ CARRIER

ARTICLE	PART NO.	DESCRIPTION
COMe Eval Carrier T10 GEN2	34101-0000-00-2	COM Express® Eval Carrier Type 10 Gen 2
COMe RefCarrier-i T10 TNIP	34105-0000-00-0	COM Express® Reference Carrier-i Type 10 Thin-nanoITX Professional

▶ COOLING

ARTICLE	PART NO.	DESCRIPTION
HSP COMe-mAL10 (E2) THREAD	34009-0000-99-0	Heatspreader for COMe-m(4)AL10 commercial and E2, threaded mounting holes
HSP COMe-mAL10 (E2) THROUGH	34009-0000-99-1	Heatspreader for COMe-m(4)AL10 commercial and E2, through holes
HSP COMe-mAL10 (E2) SLIM THREAD	34009-0000-99-2	Heatspreader Slimline 6.5mm for COMe-m(4)AL10 commercial and E2, threaded mounting holes
HSP COMe-mAL10 (E2) SLIM THROUGH	34009-0000-99-3	Heatspreader Slimline 6.5mm for COMe-m(4)AL10 commercial and E2, through holes

▶ Global Headquarters

Kontron S&T AG

Lise-Meitner-Str. 3-5
86156 Augsburg, Germany
Tel.: + 49 821 4086 0
Fax: + 49 821 4086 111
info@kontron.com
www.kontron.com