



RADIO TEST REPORT

Test Report No. 14173119H-D

Customer	Sony Interactive Entertainment Inc.
Description of EUT	Wireless communication module
Model Number of EUT	AW-XM546
FCC ID	AK8M21DAU1
Test Regulation	FCC Part 15 Subpart E: 2021
Test Result	Complied (Refer to SECTION 3)
Issue Date	March 11, 2022
Remarks	DFS test only Client without radar detection

Representative Test Engineer

Yuta Moriya
Engineer

Approved By

Takayuki Shimada
Leader



CERTIFICATE 5107.02

- The testing in which "Non-accreditation" is displayed is outside the accreditation scopes in UL Japan, Inc.
 There is no testing item of "Non-accreditation".

Report Cover Page - Form-ULID-003532 (DCS:13-EM-F0429) Issue# 20.0

ANNOUNCEMENT

- This test report shall not be reproduced in full or partial, without the written approval of UL Japan, Inc.
- The results in this report apply only to the sample tested.
- This sample tested is in compliance with the limits of the above regulation.
- The test results in this test report are traceable to the national or international standards.
- This test report must not be used by the customer to claim product certification, approval, or endorsement by the A2LA accreditation body.
- This test report covers Radio technical requirements.
It does not cover administrative issues such as Manual or non-Radio test related Requirements. (if applicable)
- The all test items in this test report are conducted by UL Japan, Inc. Ise EMC Lab.
- The opinions and the interpretations to the result of the description in this report are outside scopes where UL Japan, Inc. has been accredited.
- The information provided from the applicant for this report is identified in Section 1.
- For test report(s) referred in this report, the latest version (including any revisions) is always referred.

REVISION HISTORY

Original Test Report No.: 14173119H-D

Revision	Test Report No.	Date	Page Revised Contents
- (Original)	14173119H-D	March 11, 2022	-

Reference: Abbreviations (Including words undescribed in this report)

A2LA	The American Association for Laboratory Accreditation	ICES	Interference-Causing Equipment Standard
AC	Alternating Current	IEC	International Electrotechnical Commission
AFH	Adaptive Frequency Hopping	IEEE	Institute of Electrical and Electronics Engineers
AM	Amplitude Modulation	IF	Intermediate Frequency
Amp, AMP	Amplifier	ILAC	International Laboratory Accreditation Conference
ANSI	American National Standards Institute	ISED	Innovation, Science and Economic Development Canada
Ant, ANT	Antenna	ISO	International Organization for Standardization
AP	Access Point	JAB	Japan Accreditation Board
ASK	Amplitude Shift Keying	LAN	Local Area Network
Atten., ATT	Attenuator	LIMS	Laboratory Information Management System
AV	Average	MCS	Modulation and Coding Scheme
BPSK	Binary Phase-Shift Keying	MRA	Mutual Recognition Arrangement
BR	Bluetooth Basic Rate	N/A	Not Applicable
BT	Bluetooth	NIST	National Institute of Standards and Technology
BT LE	Bluetooth Low Energy	NS	No signal detect.
BW	BandWidth	NSA	Normalized Site Attenuation
Cal Int	Calibration Interval	NVLAP	National Voluntary Laboratory Accreditation Program
CCK	Complementary Code Keying	OBW	Occupied Band Width
Ch., CH	Channel	OFDM	Orthogonal Frequency Division Multiplexing
CISPR	Comite International Special des Perturbations Radioelectriques	P/M	Power meter
CW	Continuous Wave	PCB	Printed Circuit Board
DBPSK	Differential BPSK	PER	Packet Error Rate
DC	Direct Current	PHY	Physical Layer
D-factor	Distance factor	PK	Peak
DFS	Dynamic Frequency Selection	PN	Pseudo random Noise
DQPSK	Differential QPSK	PRBS	Pseudo-Random Bit Sequence
DSSS	Direct Sequence Spread Spectrum	PSD	Power Spectral Density
EDR	Enhanced Data Rate	QAM	Quadrature Amplitude Modulation
EIRP, e.i.r.p.	Equivalent Isotropically Radiated Power	QP	Quasi-Peak
EMC	ElectroMagnetic Compatibility	QPSK	Quadri-Phase Shift Keying
EMI	ElectroMagnetic Interference	RBW	Resolution Band Width
EN	European Norm	RDS	Radio Data System
ERP, e.r.p.	Effective Radiated Power	RE	Radio Equipment
EU	European Union	RF	Radio Frequency
EUT	Equipment Under Test	RMS	Root Mean Square
Fac.	Factor	RSS	Radio Standards Specifications
FCC	Federal Communications Commission	Rx	Receiving
FHSS	Frequency Hopping Spread Spectrum	SA, S/A	Spectrum Analyzer
FM	Frequency Modulation	SG	Signal Generator
Freq.	Frequency	SVSWR	Site-Voltage Standing Wave Ratio
FSK	Frequency Shift Keying	TR	Test Receiver
GFSK	Gaussian Frequency-Shift Keying	Tx	Transmitting
GNSS	Global Navigation Satellite System	VBW	Video BandWidth
GPS	Global Positioning System	Vert.	Vertical
Hori.	Horizontal	WLAN	Wireless LAN

CONTENTS	PAGE
SECTION 1: Customer Information	5
SECTION 2: Equipment Under Test (EUT)	5
SECTION 3: Scope of Report	8
SECTION 4: Test Specification, Procedures & Results	8
SECTION 5: Operation of EUT during testing	13
SECTION 6: Channel Move Time, Channel Closing Transmission Time	19
SECTION 7: Non-Occupancy Period	21
APPENDIX 1: Test Instruments	23
APPENDIX 2: Photographs of Test Setup	24
Test Configuration and peripherals	25

SECTION 1: Customer Information

Company Name	Sony Interactive Entertainment Inc.
Brand Name	SONY
Address	1-7-1 Konan, Minato-ku, Tokyo, 108-0075 Japan
Telephone Number	+81-50-3807-5639
Contact Person	Miho Nakamura

The information provided from the customer is as follows;

- Customer, Description of EUT, Model Number of EUT, FCC ID on the cover and other relevant pages
- Operating/Test Mode(s) (Mode(s)) on all the relevant pages
- SECTION 1: Customer Information
- SECTION 2: Equipment Under Test (EUT) other than the Receipt Date and Test Date
- SECTION 4: Operation of EUT during testing

* The laboratory is exempted from liability of any test results affected from the above information in SECTION 2 and 4.

SECTION 2: Equipment Under Test (EUT)

2.1 Identification of EUT

Description	Wireless communication module
Model Number	AW-XM546
Serial Number	Refer to SECTION 4.2
Condition	Production prototype (Not for Sale: This sample is equivalent to mass-produced items.)
Modification	No Modification by the test lab
Receipt Date	January 23, 2022
Test Date	February 20, 2022

2.2 Product Description

General Specification

Rating	DC 3.3 V
--------	----------

Radio Specification

WLAN (IEEE802.11b/11g/11n-20/11ax-20)

Equipment Type	Transceiver	
Frequency of Operation	2412 MHz to 2462 MHz	
Type of Modulation	DSSS, OFDM	
	OFDMA (IEEE802.11ax only)	20 MHz: 26/52/106/242-tone RU
Bandwidth & Channel spacing	Less than 20 MHz & 5 MHz	
Method of frequency generation	Synthesizer	
Antenna Type	PIFA	
Antenna Gain: G_{ANT}	Antenna 1: 5.0 dBi Antenna 2: 5.0 dBi	
Directional Gain *1)	8.01 dBi	
Maximum clock frequency	640 MHz	

WLAN (IEEE802.11a/11n-20/11ac-20/11ax-20/11n-40/11ac-40/11ax-40/11ac-80/11ax-80)

Equipment Type	Transceiver	
Frequency of Operation	20 M Band: 5180 MHz to 5240 MHz 5260 MHz to 5320 MHz 5500 MHz to 5720 MHz 5745 MHz to 5825 MHz	
	40 M Band: 5190 MHz to 5230 MHz 5270 MHz to 5310 MHz 5510 MHz to 5710 MHz 5755 MHz to 5795 MHz	
	80 M Band: 5210 MHz 5290 MHz 5530 MHz to 5690 MHz 5775 MHz	
Type of Modulation	OFDM	
	OFDMA (IEEE802.11ax only)	20 MHz: 26/52/106/242-tone RU
		40 MHz: 26/52/106/242/484-tone RU
80 MHz: 26/52/106/242/484/996-tone RU		
Bandwidth & Channel spacing	Less than 20 MHz / 40 MHz / 80 MHz & 20 MHz / 40 MHz / 80 MHz	
Method of frequency generation	Synthesizer	
Antenna Type	PIFA	
Antenna Gain: G_{ANT}	Antenna 1: 6.4 dBi Antenna 3: 5.0 dBi	
Directional Gain *1)	8.74 dBi	
Maximum clock frequency	640 MHz	

BT1: Bluetooth (BR / EDR / Low Energy)

Equipment Type	Transceiver
Frequency of Operation	2402 MHz to 2480 MHz
Type of Modulation	BT: FHSS (GFSK, $\pi/4$ DQPSK, 8DPSK) BT LE: GFSK
Bandwidth / Channel spacing	BT: 79 MHz / 1 MHz BT LE: 1 MHz & 2 MHz / 2 MHz
Method of frequency generation	Synthesizer
Antenna Type	PIFA
Antenna Gain	Antenna 3: 5.8 dBi
Maximum clock frequency	640 MHz

BT2: Bluetooth (BR / EDR / Low Energy)

Equipment Type	Transceiver
Frequency of Operation	2402 MHz to 2480 MHz
Type of Modulation	BT: FHSS (GFSK, $\pi/4$ DQPSK, 8DPSK) BT LE: GFSK
Bandwidth / Channel spacing	BT: 79 MHz / 1 MHz BT LE: 1 MHz & 2 MHz / 2 MHz
Method of frequency generation	Synthesizer
Antenna Type	PIFA
Antenna Gain	Antenna 4: 5.8 dBi
Maximum clock frequency	640 MHz

*1) Directional antenna gain = $10 \log \left(\frac{G_{ANT1}}{10^{20}} + \frac{G_{ANT2}}{10^{20}} \right)^2 / 2$

*This test report applies to Wireless LAN (5 GHz Band) part.

SECTION 3: Scope of Report

This report only covers DFS requirement, as specified by the following referenced procedures.

SECTION 4: Test Specification, Procedures & Results

4.1 Test Specification

Test Specification	FCC Part 15 Subpart E FCC Part 15 final revised on May 3, 2021 and effective July 2, 2021
Title	FCC 47CFR Part15 Radio Frequency Device Subpart E Unlicensed National Information Infrastructure Devices Section 15.407 General technical requirements

Test Specification	KDB905462 D02 UNII DFS Compliance Procedures New Rules v02
Title	COMPLIANCE MEASUREMENT PROCEDURES FOR UNLICENSED- NATIONAL INFORMATION INFRASTRUCTURE DEVICES OPERATING IN THE 5250-5350MHz AND 5470-5725MHz BANDS INCORPORATING DYNAMIC FREQUENCY SELECTION

Test Specification	KDB905462 D03 Client Without DFS New Rules v01r02
Title	U-NII CLIENT DEVICES WITHOUT RADAR DETECTION CAPABILITY

FCC Part 15.31 (e)

The stable voltage will be supplied by the end product, which will be required to have a power supply regulator. Therefore, the EUT complies with the requirement.

FCC Part 15.203/212 Antenna requirement

The EUT has a unique coupling/antenna connector (U.FL). Therefore, the equipment complies with the antenna requirement of Section 15.203.

4.2 Procedures and Results

Table 1: Applicability of DFS Requirements

Requirement	Operating Mode	Test Procedures & Limits	Deviation	Results
	Client without Radar Detection			
U-NII Detection Bandwidth	Not required	KDB905462 D02 UNII DFS Compliance Procedures New Rules v02	N/A	N/A
Initial Channel Availability Check Time	Not required	FCC15.407 (h)	N/A	N/A
		KDB905462 D02 UNII DFS Compliance Procedures New Rules v02		
		RSS-247 6.3		
Radar Burst at the Beginning of the Channel Availability Check Time	Not required	FCC15.407 (h)	N/A	N/A
		KDB905462 D02 UNII DFS Compliance Procedures New Rules v02		
		RSS-247 6.3		
Radar Burst at the End of the Channel Availability Check Time	Not required	FCC15.407 (h)	N/A	N/A
		KDB905462 D02 UNII DFS Compliance Procedures New Rules v02		
		RSS-247 6.3		
In-Service Monitoring for Channel Move Time, Channel Closing Transmission Time	Yes	FCC15.407 (h)	N/A	Complied a)
		KDB905462 D02 UNII DFS Compliance Procedures New Rules v02		
		RSS-247 6.3		
In-Service Monitoring for Non-Occupancy period	Yes *1)	FCC15.407 (h)	N/A	Complied b)
		KDB905462 D02 UNII DFS Compliance Procedures New Rules v02		
		RSS-247 6.3		
Statistical Performance Check	Not required	FCC15.407 (h)	N/A	N/A
		KDB905462 D02 UNII DFS Compliance Procedures New Rules v02		
<p>Note: UL Japan, Inc.'s EMI Work Procedures No. 13-EM-W0422.</p> <p>* This EUT does not support preamble puncturing (channel puncturing) on 802.11ax.</p> <p>*1) Although this test was not required in FCC, KDB 905462 D02, it was performed as additional test.</p> <p>a) Refer to SECTION 6, clause 6.3</p> <p>b) Refer to SECTION 7, clause 7.3</p>				
<p>Symbols:</p> <p>Complied The data of this test item has enough margin, more than the measurement uncertainty.</p> <p>Complied# The data of this test item meets the limits unless the measurement uncertainty is taken into consideration</p>				

Table 2 DFS Detection Thresholds for Master Devices and Client Devices With Radar Detection

Maximum Transmit Power	Value (See Notes 1,2, and 3)
≥ 200 milliwatt	-64 dBm
< 200 milliwatt and power spectral density < 10dBm/MHz	-62 dBm
< 200 milliwatt that do not meet the power spectral density requirement	-64 dBm
<p>Note 1: This is the level at the input of the receiver assuming a 0 dBi receive antenna.</p> <p>Note 2: Throughout these test procedures an additional 1 dB has been added to the amplitude of the test transmission waveforms to account for variations in measurement equipment. This will ensure that the test signal is at or above the detection threshold level to trigger a DFS response.</p> <p>Note 3: EIRP is based on the highest antenna gain. For MIMO devices refer to KDB Publication 662911 D01.</p>	

Table 3 DFS Response Requirement Values

Parameter	Value
Non-occupancy period	Minimum 30 minutes
Channel Availability Check Time	60 seconds
Channel Move Time	10 seconds See Note 1
Channel Closing Transmission Time	200 milliseconds + an aggregate of 60 milliseconds over remaining 10 second period. See Notes 1 and 2
U-NII Detection Bandwidth	Minimum 100 % of the U-NII 99 % transmission power bandwidth See Note 3
<p>Note 1: Channel Move Time and the Channel Closing Transmission Time should be performed with Radar Type 0. The measurement timing begins at the end of the Radar Type 0 burst.</p> <p>Note 2: The Channel Closing Transmission Time is comprised of 200 milliseconds starting at the beginning of the Channel Move Time plus any additional intermittent control signals required to facilitate a Channel move (an aggregate of 60 milliseconds) during the remainder of the 10 second period. The aggregate duration of control signal will not count quiet periods in between transmissions.</p> <p>Note 3: During the U-NII Detection Bandwidth detection test, radar type 0 should be used. For each frequency step the minimum percentage of detection is 90 percent. Measurements are performed with no data traffic.</p>	

Table 4 Short Pulse Radar Test Waveform

Radar Type	Pulse Width (μsec)	PRI (μsec)	Number of Pulses	Minimum Percentage of Successful Detection	Minimum Number of Trials
0	1	1428	18	See Note 1	See Note 1
1	1	Test A: 15 unique PRI values randomly selected from the list of 23 PRI values in Table 5a	Roundup $\{(1/360)^* (19*10^6/PRI \text{ μsec})\}$	60 %	30
		Test B: 15 unique PRI values randomly selected within the range of 518-3066 μsec, with a minimum increment of 1 μsec, excluding PRI values selected in Test A			
2	1-5	150-230	23-29	60 %	30
3	6-10	200-500	16-18	60 %	30
4	11-20	200-500	12-16	60 %	30
Aggregate (Rader Types 1-4)				80 %	120
Note 1: Short Pulse Radar Type 0 should be used for the detection bandwidth test, channel move time, and channel closing time tests.					

Table 5 Long Pulse Radar Test Waveform

Radar Type	Pulse Width (μsec)	Chip Width (MHz)	PRI (μsec)	Number of Pulses per Burst	Number of Burst	Minimum Percentage of Successful Detection	Minimum Number of Trials
5	50-100	5 - 20	1000-2000	1-3	8-20	80 %	30

Table 6 Frequency Hopping Radar Test Waveform

Radar Type	Pulse Width (μsec)	PRI (μsec)	Pulse per Hop (kHz)	Hopping Rate (kHz)	Hopping Sequence Length (msec)	Minimum Percentage of Successful Detection	Minimum Number of Trials
6	1	333	9	0.333	300	70 %	30

4.3 Addition to Standard

No addition, exclusion nor deviation has been made from the standard.

4.4 Test Location

UL Japan, Inc. Ise EMC Lab.

*A2LA Certificate Number: 5107.02 / FCC Test Firm Registration Number: 884919

ISED Lab Company Number: 2973C / CAB identifier: JP0002

4383-326 Asama-cho, Ise-shi, Mie-ken 516-0021 JAPAN

Telephone: +81 596 24 8999, Facsimile: +81 596 24 8124

Test site	Width x Depth x Height (m)	Size of reference ground plane (m) / horizontal conducting plane	Other rooms	Maximum measurement distance
No.1 semi-anechoic chamber	19.2 x 11.2 x 7.7	7.0 x 6.0	No.1 Power source room	10 m
No.2 semi-anechoic chamber	7.5 x 5.8 x 5.2	4.0 x 4.0	-	3 m
No.3 semi-anechoic chamber	12.0 x 8.5 x 5.9	6.8 x 5.75	No.3 Preparation room	3 m
No.3 shielded room	4.0 x 6.0 x 2.7	N/A	-	-
No.4 semi-anechoic chamber	12.0 x 8.5 x 5.9	6.8 x 5.75	No.4 Preparation room	3 m
No.4 shielded room	4.0 x 6.0 x 2.7	N/A	-	-
No.5 semi-anechoic chamber	6.0 x 6.0 x 3.9	6.0 x 6.0	-	-
No.5 measurement room	6.4 x 6.4 x 3.0	6.4 x 6.4	-	-
No.6 shielded room	4.0 x 4.5 x 2.7	4.0 x 4.5	-	-
No.6 measurement room	4.75 x 5.4 x 3.0	4.75 x 4.15	-	-
No.7 shielded room	4.7 x 7.5 x 2.7	4.7 x 7.5	-	-
No.8 measurement room	3.1 x 5.0 x 2.7	3.1 x 5.0	-	-
No.9 measurement room	8.8 x 4.6 x 2.8	2.4 x 2.4	-	-
No.10 shielded room	3.8 x 2.8 x 2.8	3.8 x 2.8	-	-
No.11 measurement room	4.0 x 3.4 x 2.5	N/A	-	-
No.12 measurement room	2.6 x 3.4 x 2.5	N/A	-	-

4.5 Uncertainty

The following uncertainties have been calculated to provide a confidence level of 95% using a coverage factor k=2. Time Measurement uncertainty for this test was: (\pm) 0.012%

4.6 Test Instruments of DFS and Test Set Up

Refer to APPENDIX.

SECTION 5: Operation of EUT during testing

5.1 Operating Modes

The EUT, which is a Client Device without Radar detection capability, operates over the U-NII-2A and U-NII-2C Band.

The channel-loading of approximately 17% or greater was used for testing, and its test data was transferred from the Master Device to the Client Device for all test configurations.

The EUT utilizes the 802.11a/n/ac/ax architecture, with a 20 MHz, 40 MHz and 80 MHz channel bandwidth.

The FCC ID for the Master Device used with EUT for DFS testing is LDK102087.

The rated output power of the Master unit is >200 mW(23 dBm). Therefore the required interference threshold level is -64 dBm. After correction for antenna gain and procedural adjustments, the required conducted threshold at the antenna port is $-64 + 1 + 0 = -63.0$ dBm (threshold level + additional 1 dB + antenna gain).

It is impossible for users to change DFS control, because the DFS function is written on the firmware and users cannot access it.

The EUT was set by the software as follows:

Software name: iPerf

Version: 2.0.5

(Date: February 22, 2021, Storage location: Driven by connected PC)

5.2 Configuration and Peripherals

This page has been submitted for a separate exhibit.

5.3 Test and Measurement System

System Overview

The measurement system is based on a conducted test method.

The software selects waveform parameters from within the bounds of the signal type on a random basis using uniform distribution. The short pulse types 1, 2, 3, and 4, the long pulse type 5, and the frequency hopping type 6 parameters are randomized at run-time.

The signal monitoring equipment consists of a spectrum analyzer with the capacity to display 8001 bins on the horizontal axis. A time-domain resolution of 2 msec/bin is achievable with a 16 second sweep time, meeting the 10 seconds short pulse reporting criteria. The aggregate ON time is calculated by multiplying the number of bins above a threshold during a particular observation period by the dwell time per bin, with the analyzer set to peak detection.

Frequency Hopping Radar Waveform Generating Subsystem

The first 100 frequencies are selected out of the hopping sequence of the randomized 475 hop frequencies.

Only a *Burst* that has the frequency falling within the receiver bandwidth of the tested U-NII device is selected among those frequencies. (Frequency-domain simulation). The radar waveform generated at the start time of the selected *Burst* (Time-domain simulation) is download to the Signal Generator.

If all of the randomly selected 100 frequencies do not fall within the receiver bandwidth of the U-NII device, the radar waveform is not used for the test.

Conducted Methods System Block Diagram

<Client mode>

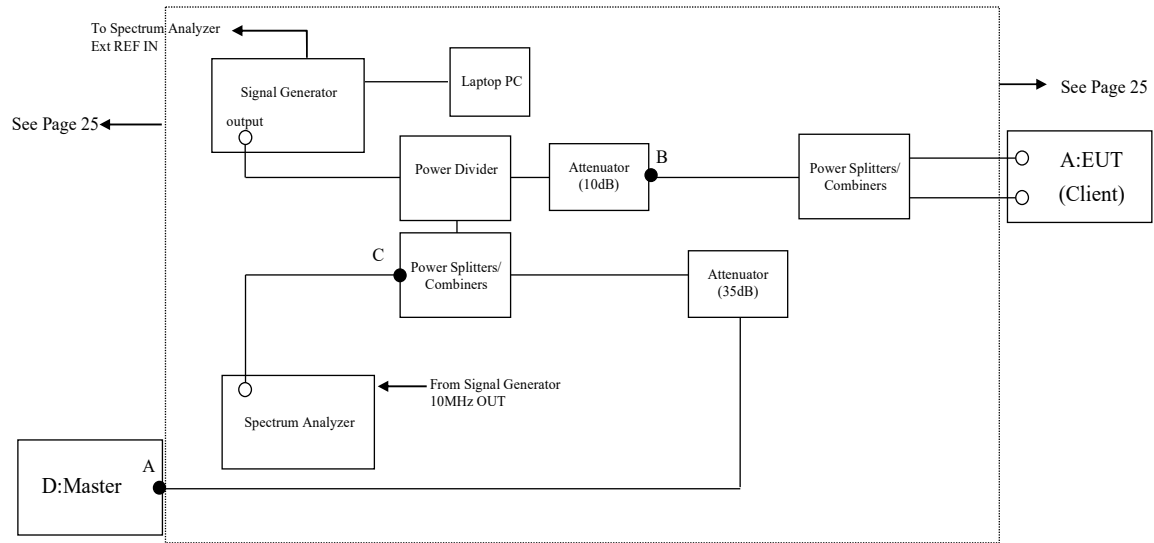

Measurement System Frequency Reference

Lock the signal generator and the spectrum analyzer to the same reference sources as follows: Connect the 10 MHz OUT on the signal generator to the EXT REF IN on the spectrum analyzer and set the spectrum analyzer Ext to On.

System Calibration

Step 1: Set the system as shown in Figure 3 of KDB905462 D02 7.2.2.

Step 2: Adjust each attenuator to fulfill the following three conditions:

- WLAN can be communicated, and
- Rader detection threshold level is bigger than Client Device traffic level on the spectrum analyzer, and
- Master Device traffic level is not displayed on the spectrum analyzer.

Step 3: Terminate 50 ohm at B and C points, and connect the spectrum analyzer to the point A. (See the figure on page 16) At the point A, adjust the signal generator and spectrum analyzer to the center frequency of the channel to be measured.

Download the applicable radar waveforms to the signal generator. Select the radar waveform, trigger a burst manually and measure the amplitude on the spectrum analyzer. Readjust the amplitude of the signal generator as required so that the peak level of the waveform is at a displayed level equal to the required or desired interference detection threshold.

Separate signal generator amplitude settings are determined as required for each radar type.

Step 4: Without changing any of the instrument settings, restore the system setting to Step 2 and adjust the Reference Level Offset of the spectrum analyzer to the level at Step 3.

By taking the above steps 1 to 4, the spectrum analyzer displays the level of the signal generator as received at the antenna ports of the Master Device.

See Clause 5.4 for Plots of Noise, Rader Waveforms, and WLAN signals.

5.4 Plots of Noise, Rader Waveforms, and WLAN Signals

<Client mode>

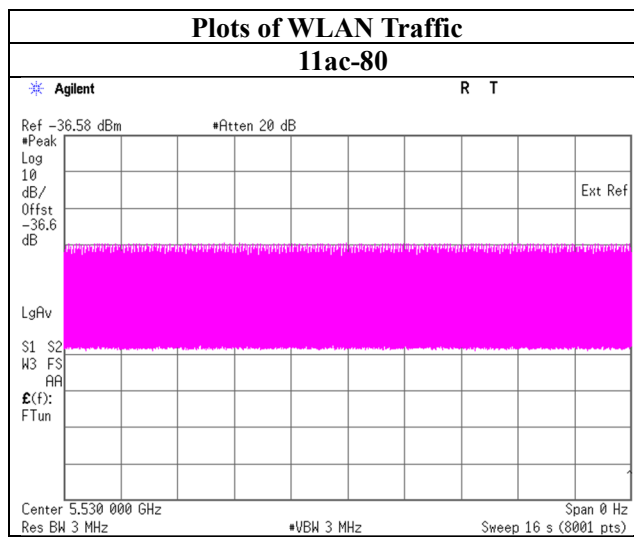
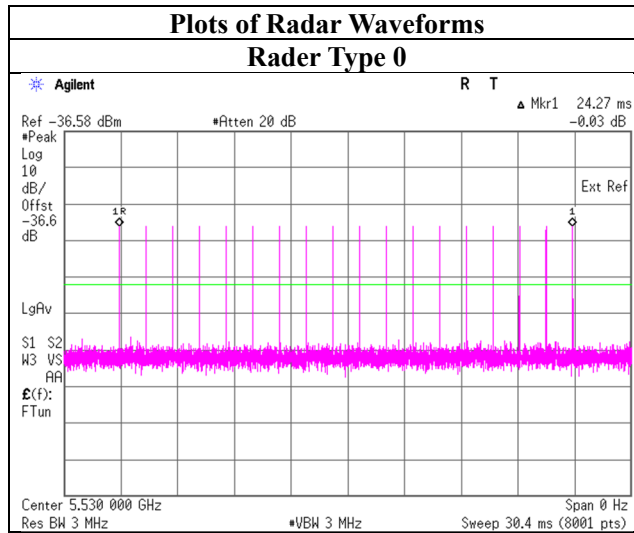
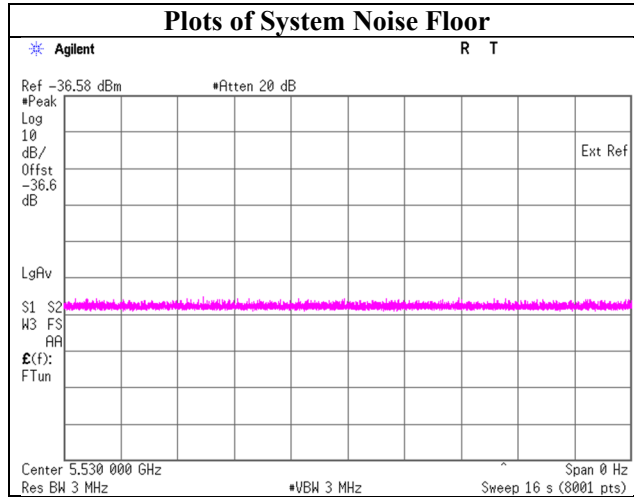

SECTION 6: Channel Move Time, Channel Closing Transmission Time

6.1 Operating Environment

Test place Ise EMC Lab.No.3 Preparation Room
 Date February 20, 2022
 Temperature/ Humidity 24deg. C / 31% RH
 Engineer Yuta Moriya
 Mode 11ac-80

6.2 Test Procedure

Transmit the data from the Master Device to the Client Device on the test Channel for the entire period of the test. The Radar Waveform generator sends a Burst of pulses for the Short Pulse Radar Types 0 at levels defined , on the Operating Channel. An additional 1 dB is added to the radar test signal to ensure it is at or above the DFS Detection Threshold, accounting for equipment variations/errors.

Observe the transmissions of the EUT at the end of the radar Burst on the Operating Channel for duration greater than 10 seconds.

6.3 Test Data

<Client Device>

11ac-80

Test Item	Unit	Measurement Time	Limit	Results
Channel Move Time *1)	[sec]	3.012	10.000	Pass
Channel Closing Transmission Time *2)	[msec]	4	60	Pass

*1) Channel Move Time is calculated as follows:

$$(\text{Channel Move Time}) = (\text{End of Transmission}) - (\text{End of Burst}) = 3.868 - 0.856$$

*2) Channel Closing Transmission Time is calculated from (End of Burst + 200msec) to (End of Burst + 10sec)

$$(\text{Channel Closing Transmission Time}) = (\text{Number of analyzer bins showing transmission}) \times (\text{dwell time per bin}) = 2 \times 2 \text{ [msec]}$$

<Client mode>

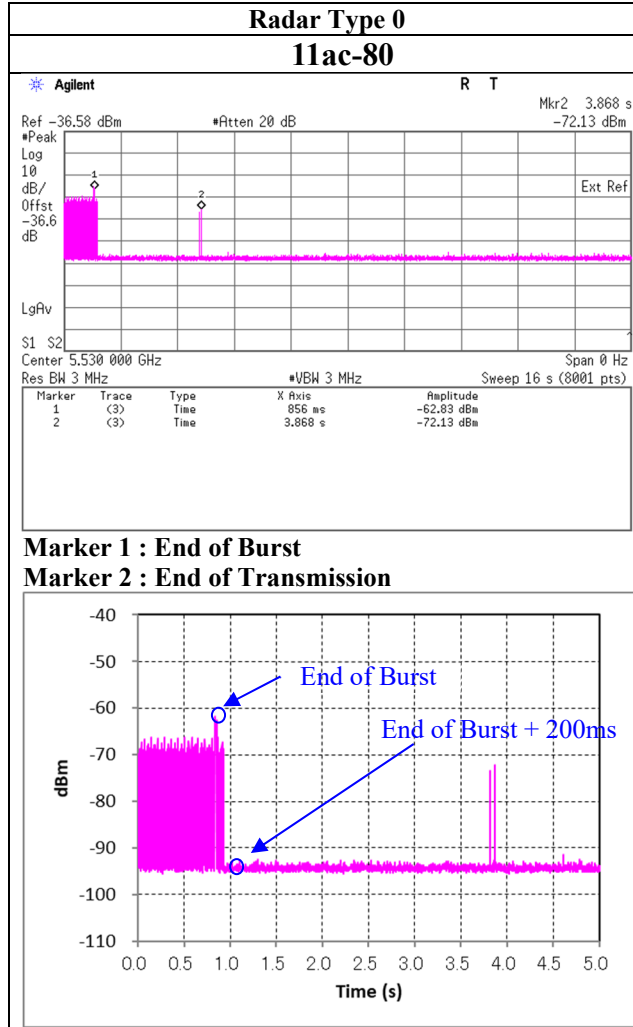

6.4 Test Result

Test result: Pass

SECTION 7: Non-Occupancy Period

7.1 Operating Environment

Test place	Ise EMC Lab.No.3 Preparation Room
Date	February 20, 2022
Temperature/ Humidity	24deg. C / 31% RH
Engineer	Yuta Moriya
Mode	11ac-80

7.2 Test Procedure

The following two tests are performed:

1). Transmit the data from the Master Device to the Client Device on the test Channel for the entire period of the test. The Radar Waveform generator sends a Burst of pulses for the Radar Types 0 at levels defined on the Operating Channel. An additional 1 dB is added to the radar test signal to ensure it is at or above the DFS Detection Threshold, accounting for equipment variations/errors. Observe the transmissions of the EUT after the Channel Move Time on the Operating Channel for duration greater than 30 minutes.

7.3 Test Data

<Client mode>

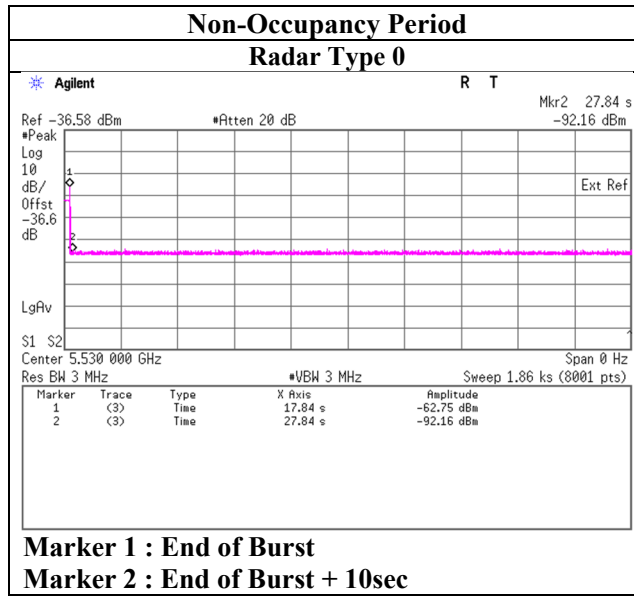

7.4 Test Result

Test Result: Pass

APPENDIX 1: Test Instruments

Test Equipment

Test Item	Local ID	LIMS ID	Description	Manufacturer	Model	Serial	Last Calibration Date	Cal Int
DFS	MOS-29	141568	Thermo-Hygrometer	CUSTOM. Inc	CTH-201	2901	01/10/2022	12
DFS	MSA-03	141884	Spectrum Analyzer	Keysight Technologies Inc	E4448A	MY44020357	03/10/2021	12
DFS	MSG-18 *1)	141898	Signal Generator	Keysight Technologies Inc	N5182B	MY56200177	11/04/2021	12
DFS	COTS-MDFS-03	170949	Signal Studio for DFS Radar Profiles	EMC Instruments Corporation	N7607B	-	-	-
DFS	MCC-189	142376	Microwave Cable	Junkosha	MWX-221-02000DMSDMS	1507S108	-	-
DFS	MCC-190	142377	Microwave Cable	Junkosha	MWX-221-02000DMSDMS	1507S109	-	-
DFS	MCC-177	141226	Microwave Cable	Junkosha	MMX221-00500DMSDMS	1502S304	03/01/2021	12
DFS	MCC-151	142345	Microwave Cable	Junkosha	MWX221-01000AMSAMS	1304S248	-	-
DFS	MCC-244	197219	Microwave cable	Huber+Suhner	SF126E/11PC35/11PC35/2000MM	536999/126E	03/04/2021	12
DFS	MPSC-04	141821	Power Splitters/Combiners	Mini-Circuits	ZFSC-2-10G	0326	09/30/2021	12
DFS	MPSC-07	142736	Power Splitters/Combiners	Pasternack Enterprises	ZFRSC-123-S+	ZFRSC-123-00232	-	-
DFS	MPD-04	141592	Power Divider DC-12.4GHz	Suhner	4901.19.A	-	05/11/2021	12
DFS	MAT-88	141312	Attenuator	Weinschel Associates	WA56-10	56100304	05/14/2021	12
DFS	MAT-101	194879	Attenuator	Keysight Technologies Inc	8495A / 8495B	MY42150956 / MY42147424	-	-

*Hyphens for Last Calibration Date and Cal Int (month) are instruments that Calibration is not required (e.g. software), or instruments checked in advance before use.

*1) Signal generator is only used to generate radar test signal, and the wave form is confirmed with spectrum analyzer every time before the test.

The expiration date of the calibration is the end of the expired month.

As for some calibrations performed after the tested dates, those test equipment have been controlled by means of an unbroken chains of calibrations.

All equipment is calibrated with valid calibrations. Each measurement data is traceable to the national or international standards.

Test item:

DFS: Dynamic Frequency Selection