

Freezer i13 X CO



Compact Intel CPU Cooler for Continuous Operation



- Secure hold with backplate
- Pre-applied MX-2 thermal paste
- Extended lifespan thanks to low motor temperature
- Lower power consumption and less vibration with new motor technology
- Offset heat pipes ensure optimal heat dissipation
- Focused airstream for improved cooling performance

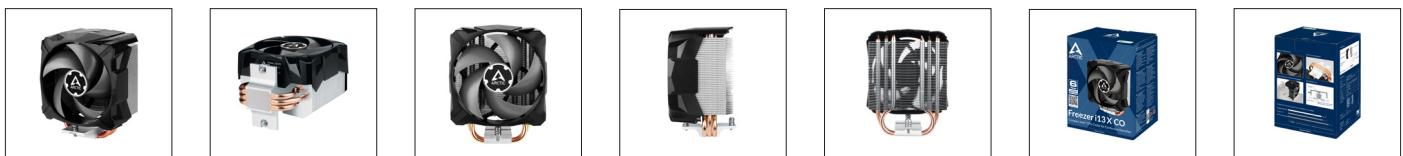

Here is the Freezer i13 X CO – Ready to cool your Intel CPU

The ARCTIC Freezer i13 X CO is a compact CPU cooler with one 100 mm fan. It benefits from an improved heatsink design and a reworked heat pipe layout. In conjunction with the fan, which is optimised for high static pressure, ARCTIC was able to significantly improve the Freezer i13 X CO's cooling performance. With the use of a double ball bearing it is designed for continuous operation and is therefore also suitable for 24/7 operations. It is supplied with pre-applied ARCTIC MX-2 thermal compound and has a simple assembly system.

Specifications

Heat Pipe	Direct Touch Ø 6 mm x 3
Heatsink	Aluminium Fins x 44 Thickness: 0.4 mm
Thermal Compound	MX-2 pre-applied
Dimensions	85.5 (L) x 112 (W) x 137 (H) mm
Weight	425 g
Compatibility	Intel® 1700*, 1200, 115x

*separate kit available on request

RAM Clearance	no limit
Fan	1 x 100 mm, 300–2000 RPM (Controlled by PWM)
Current/Voltage	0.07 A/12 V
Bearings	Double Ball Bearing
Noise Level	0.3 Sone
Connector	4-pin connector



Small Footprint for optimal Compatibility

The Freezer i13 X CO combines a compact advanced heat sink design with 3 direct touch heat pipes. In combination with the fan designed for static pressure, an optimal cooling performance is achieved despite the comparatively small dimensions. The Freezer i13 X CO has an installation height of only 137 mm and there are no limitations in RAM compatibility.



Pre-applied MX-2 Thermal Paste

Pre-applied, high-performing MX-2 thermal paste ensures quick and clean assembly.

Freezer i13 X CO



Compact Intel CPU Cooler

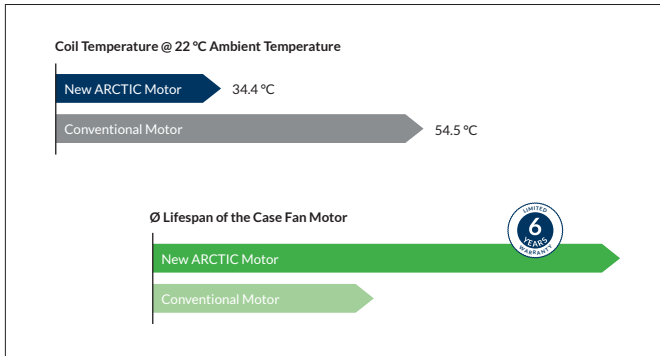

Longer Lifespan thanks to its Low Motor Temperature

The Freezer i13 X CO uses a fan motor newly developed by ARCTIC. This runs less audibly and more efficiently, so that the temperature of the coils is 20 °C lower than with conventional motors. This increases the lifespan of the fans considerably, allowing ARCTIC to grant a 6-year warranty period for the Freezer i13 X CO.

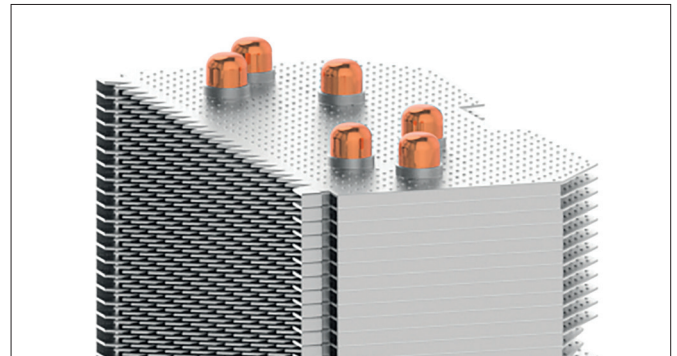

Offset Heat Pipes enable Optimal Heat Dissipation

The direct touch heat pipes attached to the Freezer i13 X CO and an optimised design of the 44 cooling fins together ensure that the heat from the CPU can be ideally removed and released into the air.



P-fan for Increased Performance

Inspired by the P-series, the Freezer i13 X CO's fan benefits from all of the advantages of P-fans:

- High static pressure for increased cooling performance
- Broad RPM range
- Lower power consumption
- Less vibration
- PWM for synchronous fan control

For additional information about the P-fans, we recommend our FAQ.

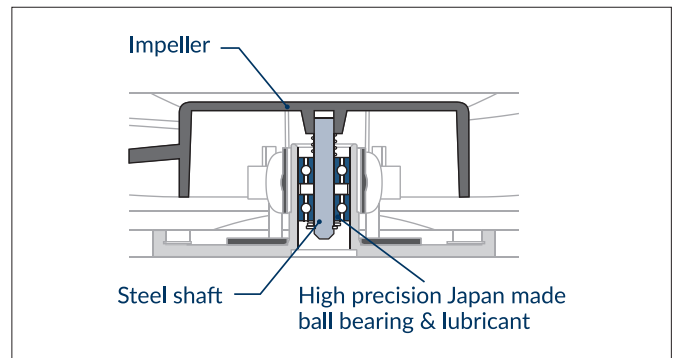

Double Ball Bearing for Continuous Operation

The premium quality dual ball bearing allows continuous operation 24/7 without the slightest compromise in performance. Dust and high temperature are affecting this bearing a lot less than generic sleeve or one ball bearings and thus make it the perfect choice when reliability is essential.

Freezer i13 X CO

Compact Intel CPU Cooler

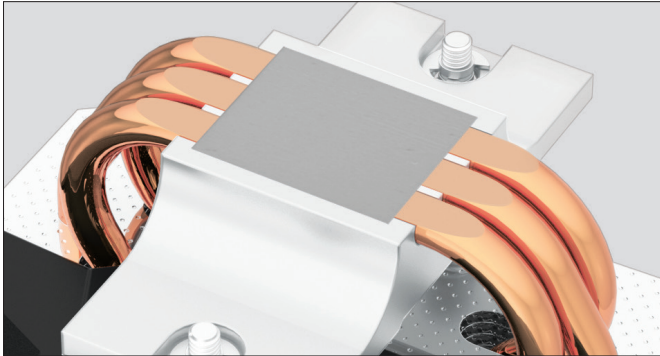

Direct Touch Heat Pipes

The Freezer i13 X CO uses direct touch heat pipes. This ensures that the heat to be dissipated is transferred directly to the heat pipes without an additional material layer, and transported into the heatsink via the pipes.

Cooling Performance for Intel Core i7 8700K OC 6x 4.40GHz

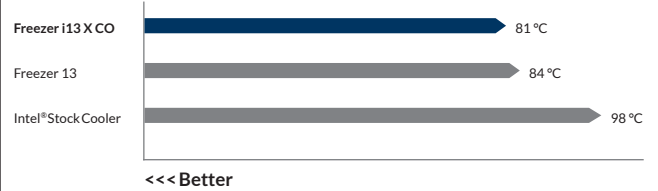

Tested with Prime 95 Small FFT in a standard tower PC case, CPU cooler set at full speed

More Cooling Capacity with Freezer i13 X CO

The ARCTIC Freezer i13 X CO sets new standards in cooling. Proven to outperform its predecessor in cooling capacity.

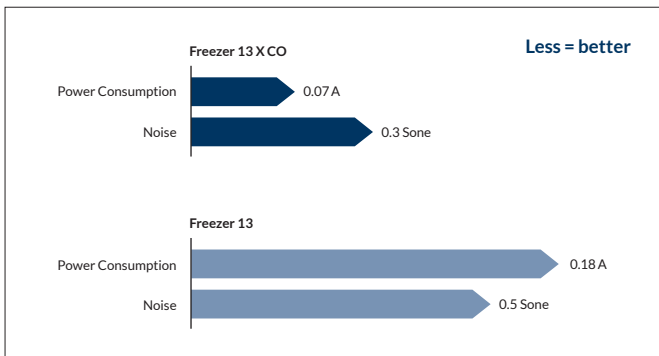

More Efficient and Whisper Quiet

In addition to operating more quietly, even at maximum speed, the Freezer i13 X CO's built-in fan motor is also much more efficient.

The power consumption was reduced from 0.18 A to 0.07 A, which corresponds to an effective savings of 60% in power consumption. ARCTIC engineers were also able to reduce the volume by 40%, allowing the Freezer i13 X CO to run at a whisper-quiet 0.3 sone when at maximum speed.



Multilingual Manuals

ARCTIC offers a regularly updated user manual in many languages conveniently at your fingertips anywhere and anytime. Put the QR code sticker in an easy-to-reach place and never again waste time searching for product instructions.



Product Information



Manual