

# HP Network Design Consulting Guide

Spring 1998

Not for customer use



HP Networking

Less Work, More Network

---

# HP Network Design Consulting Guide



---

"Less Work, More Network"

# Preface

Your customers rely on your networking knowledge and business acumen. You translate their business needs into technology requirements, and use effective sales and communication skills to help you sell your solution. The goal of this guide is to help you develop and sell Local Area Networking solutions. It provides you with technical sales information imperative to good LAN design including product recommendations.

The culmination of your work is often presented as a network proposal, thus the network proposal will be used as a foundation for this guide.



To complete a network proposal, you:

- Analyze your client: Describe existing networks, future growth, and time frame for the changes.
- Identify networking requirements: Note mandated networking requirements and physical restrictions.
- Recommend a technology: Provide technology recommendations and the reasons behind the technical recommendations.
- Design a network: Recommend a network design. Include how business needs will be met with the proposed design.
- Provide product description and parts list: Prepare a shopping list for all new networking equipment specified in the design.

Use this guide to help you complete a network proposal. It is organized as follows:

- Chapter 1: HP: “Less Work, More Network” What’s New in 1998
- Chapter 2: HP Proactive Networking
- Chapter 3: Analyzing Your Customers
- Chapter 4: Solution Topologies
- Chapter 5: HP Networking Products
- Chapter 6: Switching Technology

To easily identify hubs, switches, and routers, we've established the following symbols:

Network Equipment	Symbol
Hub	
Switch	
Router	

Hewlett-Packard is the official Information Technology Hardware supplier and the Official Supplier of IT Hardware Maintenance of the 1998 Football/Soccer World Cup. Look for HP Hubs and Switches as the network foundation at all World Cup 1998 sites.





---

# Contents

<b>Chapter 1:</b>	<b>HP: “Less Work, More Network” What’s new in 1998</b>	
	HP Networking Awards .....	1-1
	HP Proactive Networking Design Tool .....	1-2
	HP Network DesignCenter .....	1-3
	HP AdvanceStack Assistant for Resellers .....	1-4
<b>Chapter 2:</b>	<b>Proactive Networking</b>	
	Finds, Fixes, and Informs .....	2-2
	Recommends Performance Enhancements using Network Performance Advisor .....	2-3
	Provides Anywhere Management .....	2-4
	Supports Multicast Applications .....	2-6
	Supports Multiport Trunking .....	2-8
	Provides Industry-Leading Support .....	2-9
	HP Proactive Networking .....	2-9
<b>Chapter 3:</b>	<b>Analyzing Your Customers</b>	
	Information Gathering .....	3-1
	The Current Physical Network Map .....	3-1
	Current and Future Applications .....	3-2
	Current LAN Usage Model (what’s working and what’s not working) .....	3-2
	Internet Connection .....	3-3
	Network Management Needs .....	3-3
<b>Chapter 4:</b>	<b>Solution Topologies</b>	
	<b>Building the LAN</b> .....	4-3
	10Mbps Connections: 5–50 Nodes .....	4-6
	10Mbps Connections: 50–200 Nodes .....	4-10
	10Mbps Connections: 200–1000 Nodes .....	4-14
	High-Speed Connections: 5–50 Nodes .....	4-18
	High-Speed Connections: 50–200 Nodes .....	4-22
	High-Speed Connections: 200–1000 Nodes .....	4-26
	Guaranteed-Bandwidth Connections: 5–50 Nodes .....	4-30
	Guaranteed-Bandwidth Connections: 50–200 Nodes .....	4-34
	Guaranteed-Bandwidth Connections: 200–1000 Nodes .....	4-38



<b>Adding Internet Connectivity</b> .....	4-42
<b>Connecting Remote Sites</b> .....	4-45

## **Chapter 5: HP Networking Products**

<b>Network Management</b> .....	5-2
HP AdvanceStack Assistant .....	5-2
Traffic Monitor .....	5-3
Network Performance Advisor .....	5-4
Features .....	5-4
Competitive Strengths .....	5-5
<b>Switches: Product Summary</b> .....	5-6
<b>Switches: Product Summary</b> .....	5-7
The HP AdvanceStack Family of Switches .....	5-8
Why Switching? .....	5-8
<b>HP AdvanceStack Switch 2000</b> .....	5-10
Switch 2000 Product Features .....	5-11
Competitive Strengths .....	5-12
Suggested Demonstration Features .....	5-13
More Competitive/Product Information .....	5-13
Frequently Asked Questions .....	5-13
<b>HP AdvanceStack Switch 800T</b> .....	5-14
Switch 800T Product Features .....	5-15
Competitive Strengths .....	5-15
Suggested Demonstration Features .....	5-17
More Competitive/Product Information .....	5-17
Frequently Asked Questions .....	5-17
<b>HP AdvanceStack Switch 208T/224T</b> .....	5-18
Switch 208/224 Product Features .....	5-19
Competitive Strengths .....	5-20
Suggested Demonstration Features .....	5-20
More Competitive/Product Information .....	5-21
Frequently Asked Questions .....	5-21
.....	5-21
<b>Hubs: Product Summary</b> .....	5-22
The HP Family of Hubs .....	5-24
HP's 10Base-T Switching Hub Features .....	5-25
<b>HP 10Base-T Value Line Hubs</b> .....	5-26
Value Line 10Base-T Hub Features .....	5-28
Competitive Strengths .....	5-29

<b>HP AdvanceStack 100Base-T Hubs</b> .....	5-30
100Mbps Hub Features .....	5-31
Competitive Strengths .....	5-32
Suggested Demonstration Features .....	5-32
More Competitive/Product Information .....	5-32
Frequently Asked Questions .....	5-33
<b>HP AdvanceStack 100VG Hubs</b> .....	5-34
100VG Hub Features .....	5-35
Competitive Strengths .....	5-35
Frequently Asked Questions .....	5-35
<b>HP AdvanceStack Switching Hubs</b> .....	5-36
Switching Hub Features .....	5-37
Competitive Strengths .....	5-38
Suggested Demonstration Features .....	5-38
More Competitive/Product Information .....	5-38
Frequently Asked Questions .....	5-39
<b>HP AdvanceStack Internet Router</b> .....	5-40
Competitive Strengths .....	5-41
More Competitive and Product Information .....	5-41
<b>HP 10/100VG LAN Adapter Cards (NICs)</b> .....	5-42
Competitive Strengths .....	5-42
More Competitive/Price Information .....	5-43
Frequently Asked Questions .....	5-43
<b>Accessories Index</b> .....	5-44



## Chapter 6: Switching Technology

<b>Evolution from Shared Ethernet to Switched Ethernet . . . .</b>	6-1
<b>Switch Operation . . . . .</b>	6-2
Layer 2 Switches . . . . .	6-3
Local Routing . . . . .	6-4
HP Layer 3 Switching . . . . .	6-6
Layer 2, Routing, and Layer 3 Switching Comparisons . . . . .	6-8
<b>Network Switch Market Classes . . . . .</b>	6-8
Desktop/Workgroup Switch . . . . .	6-9
Segment/Departmental Switch . . . . .	6-9
Backbone/Campus/Interconnect Switch . . . . .	6-10
<b>Switch Architecture . . . . .</b>	6-11
Modes of Operation . . . . .	6-11
Architecture Design . . . . .	6-13
Switch Fabric Design . . . . .	6-13
<b>Memory Architecture . . . . .</b>	6-15
<b>Switch Performance Parameters . . . . .</b>	6-16
Throughput . . . . .	6-16
Frame/Packet Loss Rate . . . . .	6-16
Latency . . . . .	6-17
Congestion Control . . . . .	6-18
<b>Sample Switching Topologies . . . . .</b>	6-18

## Index

# Chapter 1: HP: "Less Work, More Network" What's new in 1998

---

## HP Networking Awards

Hewlett-Packard's networking products and industry-leading network support continue to receive accolades from a number of major networking publications. Recent awards include:

### **VAR Business Annual Report Card (October, 1997)**



VAR Business has awarded Hewlett-Packard's networking products and support with a first place ranking in its 1997 Annual Report Card. In an article entitled "Hewlett-Packard Products Win With New VAR Program", VAR Business states:

*"For Hewlett-Packard Co., success in the VAR channel means product, product, and product."*

VAR Business awarded a first place position in products/pricing and support under the Network Hardware category. For more information about the VAR Business Annual Report Card, visit the following website:

*<http://techweb.cmp.com/vb/arc97/profnhw.htm>*



©1995 EEL TM

**Computer Reseller News Editors' Choice Award  
HP AdvanceStack 800T Switch  
October, 1997**



Computer Reseller News has awarded its Editors' Choice Award to the HP AdvanceStack 800T switch.

*"Hewlett-Packard AdvanceStack 800T is among the most powerful and flexible of the switches in this review...Resellers configuring large-scale internetworks will like the unit's ability to control broadcast storms and multicasts, a Layer 3 function normally associated with complex network routers."*

To find out more about the Computer Reseller News Editors' Choice Award, visit the website at:

<http://www.techweb.com/se/directlink.cgi?CRN19971013S0154>



<http://www.hp.com/key/netreseller>

For more information about other networking awards bestowed on Hewlett-Packard's networking products, visit the HP networking Reseller Plaza website.

---

## HP Proactive Networking Design Tool

HP proactive networking design tool is a simple-to-use network design configuration tool enabling you to rapidly assemble uniquely tailored networks. HP proactive networking design tool will automate the network design process, significantly reducing the time needed to explore design alternatives. This tool allows you to create network designs and explore pricing alternatives.

By answering a few questions, HP proactive networking design tool generates a Bill of Materials, giving you an idea of the cost of your design.

Questions asked by the proactive networking design tool include:

- How many buildings are located at the central site?

- How many remote offices?
- By floor, what is the network technology (shared Ethernet, switched Ethernet, Fast Ethernet, 100VG, etc.), and what are the node counts?
- What are the network management requirements?

Using the above information, DesignPro recommends a network design for your solution. A network design and a bill of materials, with part numbers and prices, is automatically produced.

To access HP proactive networking design tool, visit the Reseller Plaza website.

HP proactive networking design tool provides a quick way to generate a network design and quote. If more complex designs are needed, call your HP network contact. If you do not have an HP contact, please visit the website Reseller Plaza for instructions on how to get an HP contact.



<http://www.hp.com/key/netreseller>

---

## HP Network DesignCenter

The HP Network DesignCenter and your HP sales force team are ready to assist you in selling and supporting networks. Paired with an HP contact, you can get free assistance with:

- Detailed network responses to Request for Proposals (RFP), Request for Quotations (RFQ), and Request for Information (RFI), including design recommendations and reasons why the design meets all of the customers requirements in an easy-to-read Microsoft® Word 95 format<sup>1</sup>.
- Network drawings and topologies in electronic format, including Visio 4.0 graphics.
- Complete parts list in a Microsoft Excel 95 spreadsheet.

To get the HP design team working for you:

1. Call your local HP contact. If you do not have an HP contact, visit the HP networking Reseller Plaza website at

*<http://www.hp.com/key/netreseller>*

for instructions on how you can get one.

Your HP contact will be your interface into the DesignCenter.

2. With your HP contact, complete the Job Design Interview Form. Discuss your customer's networking and business needs with your HP contact, and be sure to include:
  - Your customer name, location, and phone number
  - Date and time you must submit your response/design to your customer

---

1. Other electronic format, such as Microsoft Excel 97, Microsoft Word 97, Visio 5.0, Lotus 1-2-3, and Lotus AmiPro are available on request.

- Actual/estimated decision date of proposal
  - Contents of the RFP, RFQ, or RFI
  - Clear draft or sketch of existing network topologies and maps
  - All other network design parameters, such as servers, clients, end nodes, segments, etc.)
  - All other business needs of your customer
3. Once you and your HP contact complete the Job Design Interview Form, your HP contact will work with the technical staff at the HP DesignCenter to deliver the needed response.

The HP DesignCenter is there to help you develop network designs—leaving you time to focus on customer relationships and the actual closing of sales.

---

## HP AdvanceStack Assistant for Resellers

HP AdvanceStack Assistant for Resellers helps you give your clients solid upgrade advice, with no guesswork and no expense—and you don't have to be a network expert to do it. It collects extensive network traffic data, then produces precise, detailed recommendations for the most cost-effective ways to upgrade your network. It provides clear diagrams, and easy to read reports. It is easy to install and is being offered to you at no cost.



<http://www.hp.com/key/netreseller>

For more information about HP AdvanceStack Assistant for Resellers, see the "HP Networking Products" section of this guide or visit the HP network Reseller Plaza website.

# Chapter 2: Proactive Networking

A network administrator is responsible for keeping the network healthy and his users productive. His ability to do the job is made more difficult by the ever-increasing complexity of the network. Network traffic has risen in volume and complexity with the advent of the Internet and new, network-intensive applications. Adding the responsibilities of department budgeting, training an ever-changing technical staff, and other important business needs, the job of a network administrator can become overwhelming. You can help network administrators control their network, guarantee network uptime, and increase network performance by selling HP proactive networking. HP proactive networking is a combination of product functionality, training, world-class support, and industry-leading product warranties that reduce the cost and complexity of networking. Proactive networking:

- **Finds, Fixes, and Informs:** HP proactive networking helps the network administrator control his network and guarantee network uptime by automatically finding and fixing network problems when they start, and then informs a network administrator of the problem and the fix.
- **Recommends Performance Enhancements using Network Performance Advisor:** HP proactive networking helps the network administrator increase network performance by automatically suggesting performance enhancements. HP AdvanceStack Assistant Network Performance Advisor comes free with managed hubs and switches.
- **Provides Anywhere Management:** Using any Java-and-frames capable web browser, a network administrator can manage a network anywhere within the network, providing anywhere control.
- **Supports Multicast Applications:** With multicast-enabled HP switches, your customer can deploy multicast applications without adversely affecting network performance.
- **Supports Multi-Port Trunking:** Your customers can increase network performance without investing in new high-speed equipment. Your customers get greater flexibility because they can combine several 100Mbps links into one large link to meet their capacity needs.
- **Provides Industry-Leading Support:** HP backs its networking products with end-user telephone support, world-class warranties, and the reputation of HP's industry-leading reliability.

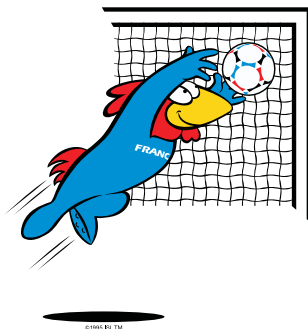

## Finds, Fixes, and Informs

"A growing number of users cannot log onto the network. To isolate the problem, my staff and I needed a network sniffer, an arsenal of spare cables, and 6 hours of time. The 6 hours really hurt. We finally traced the problem to a user with a short in the twisted-pair cable connecting his PC to the network."

If the network administrator had installed HP managed hubs and switches, HP proactive networking would have isolated the problem within seconds. HP managed hubs and switches can:

- automatically **find** the problem cable
- **fix** the uptime problem for other users by automatically disabling the affected port, and
- **inform** the network administrator about the problem port.

The network administrator saves money and time, and more importantly, minimizes network down time.

Proactive networking will also find the following:

Problem	Find	Fix	Inform
Misbehaving or misconfigured driver	Finds bad driver sending packets	Shuts the port	Tells network administrator hardware, port, and problem
Cable length exceeds specifications	Finds cable that is too long		Tells network administrator hardware, port, and problem
Over bandwidth/high congestion	Detects too many collisions and fragmented packets		Tells network administrator hardware, port, and problem
Misconfigured transceiver	Detects SQE configuration		Tells network administrator hardware, port, and problem
Loss of uplink	Detects loss of uplink		Tells network administrator hardware, port, and problem
Twisted pairs are swapped	Finds swapped wires	Compensates for the cable problem	Tells network administrator hardware, port, and problem
Bad connector/cable	Finds classic pattern of a bad connector or noise on cable		Tells network administrator hardware, port, problem
Installing a hub creates a network loop	Finds a classic pattern for a loop	Shuts the port	Tells network administrator hardware, port, problem
Installing a hub exceeds the maximum number of repeater hubs allowed	Detects hub exceeding hop count		Informs network administrator of the problem and tells network administrator what to do about it
Chattering NIC	Finds persistent classic pattern affecting network performance	Shuts the port	Tells network administrator what hardware, port, problem
Broadcast storm	Finds classic pattern	Shuts the port	Tells network administrator what hardware, port, problem
Users are complaining that the network is slow	Finds the top talker		Gauges indicate high network utilization; helps quickly locate top talker
Apparent decline in network performance	Finds the network bottleneck	Determines the best user distribution across network segment	Network administrator reads suggested user distribution and expected performance increase using the plain language report and diagrams generated via a web browser.

With the easy-to-read screens, proactive networking will help you support your customers.

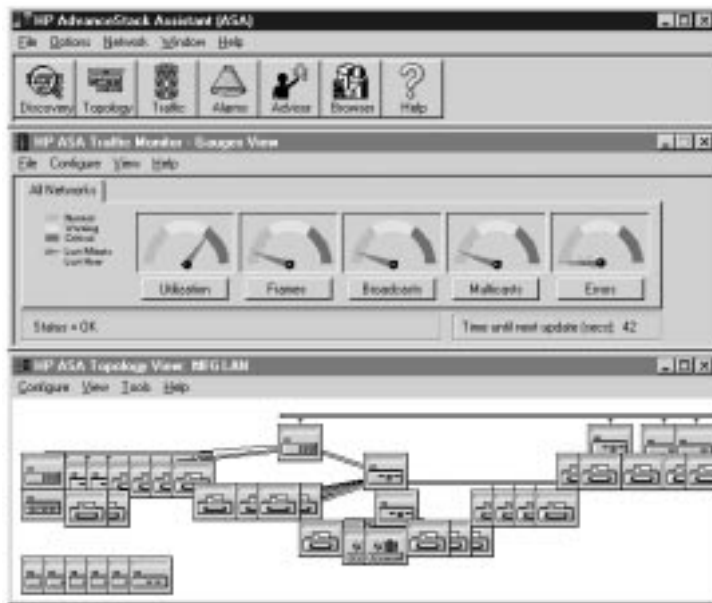

What can the **Find, Fix and Inform** feature of HP proactive networking do for you? You can sell support and not worry about chattering NICs, swapped wires and topology problems such as network loops. HP proactive networking also can help you sell HP switches and managed hubs because the functionality is embedded in the hardware, at no additional cost.

## Recommends Performance Enhancements using Network Performance Advisor

*“The shared network is slow. I know segmenting the network will help, but will it be enough to get the desired level of performance? Should I add a switch, and where should I put it? What users would I place on which segment?”*

Network Performance Advisor software, free with your managed hubs and switches, is included as a part of HP proactive networking. The Network Performance Advisor software helps you optimize your network and manage its growth. It helps you make design decisions because it gives you a view into your customer’s network—visibility you cannot get without installing an expensive network analyzer or complex network management. After sampling traffic on the network, it presents detailed recommendations using clear diagrams and plain language.



Viewed with a Web browser, the recommendations may include moving nodes, using switching technologies, or adding 100Mbps upgrades to maintain peak performance in the network.

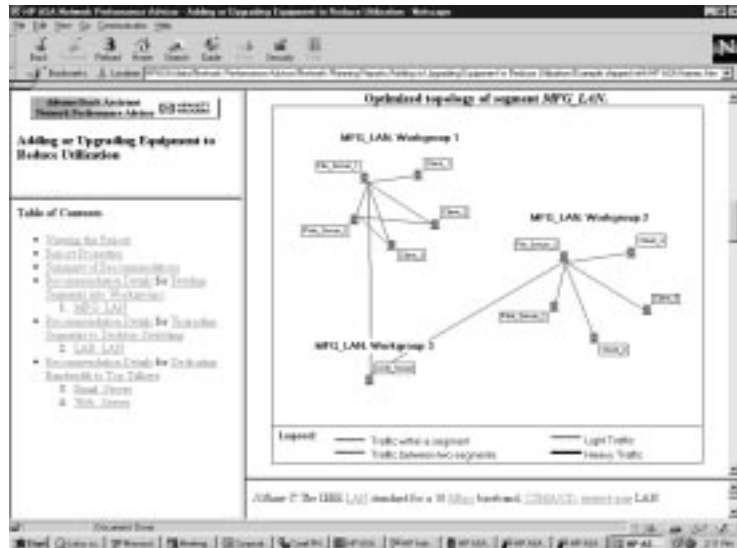

How can you use the **Recommends Performance Enhancements using Network Performance Advisor** feature of HP proactive networking? You can sell design services or offer a free network performance analysis. You can easily:

- Find opportunities to improve performance by reorganizing your customer's existing equipment.
- Find opportunities to sell new equipment to reduce network utilization.
- To learn more about Network Performance Advisor, refer to page 5-4 of this guide.

## Provides Anywhere Management

*"I want a simple, standard interface that allows me to easily manage my network. I don't want to invest in training my staff on a new application, and I don't want to invest in sophisticated, hard-to-configure network management software."*

Manage your network with HP web-based proactive networking. The agent-enabled, web-based management component of proactive networking is embedded in newly introduced HP managed hubs and switches. It consists of a Java-based Web agent and an embedded web server. In the past, if a network administrator wanted to see a graphical representation of his network or to get device-specific information, he had to first load management software on a specific station and then be at that specific station to view the screens. Network administrators can

now use any Web browser that supports Java and frames. There is no need to learn a new application. (HP recommends Netscape™ 4.03 or later for PCs and Netscape™ 3.0 or later for UNIX®. HP provides the PC version of the Netscape browser at no additional cost on the HP AdvanceStack Assistant CD shipped with HP managed hubs and switches.) The administrator sees the same human interface with the same look and feel whether the PC is running UNIX® or Microsoft Windows®—Java is operating-system independent. An administrator can use a Web browser as described above on any networked computer, day or night, to configure, control, and monitor networking devices (managed hubs and switches), and to query faults from any of these devices. Your customers will immediately see the reduced cost of ownership, since the devices can be managed with minimal effort anytime, anywhere, and with any platform.



The web agent approach is ideal for managing remote sites or managing those crisis situations that can occur at 2:00AM, *without* having to go in to the office to access a particular management station. Many older HP managed hubs and switches can also be upgraded to web-based management, free-of-charge. Please visit the HP networking Reseller Plaza website for further information on web-based management upgrades.



<http://www.hp.com/key/netreseller>

How can the **Provides Anywhere Management** feature of proactive networking help your business? You can easily sell outsource services. You can control your customer's devices from any place on the network, including your office. And if your customer chooses to support his own network, sell ease-of-use. The management of his network is made easier with web-based management, without added cost usually associated with network management.

---

## Supports Multicast Applications

*"Some internet applications demand an efficient way of communicating with a group of users on my network. What should I do?"*

Implement IP Multicast to help control your network. Multicast, or the ability of an application to send a single copy of a message to specific users on a network, is supported with the layer 3 function of HP's proactive networking. The ability to multicast is a function of LAN addressing. Three types of addressing schemes are used on a LAN:

- **Unicast:** A unicast packet on the network originates from a single node, and is received by another single node. Each conversation is between one node and another, and each conversation is considered separate traffic. The number of nodes receiving a packet is limited by the bandwidth of the network since the packet must be retransmitted each time the packet is to be received by a different node. Unicast communication is often referred to as one-to-one communication and is the typical Ethernet node-to-node mode of communication.
- **Broadcast:** A broadcast packet on the network originates from a single node and is received by all nodes on the LAN segment. A broadcast packet is often used to resolve addresses and advertise resources. Broadcast storms can affect the performance of the network. Many nodes on the network may not care about the contents of a broadcast packet, and broadcast messages cannot cross subnets. Broadcast communication is often referred to as one-to-all communication.
- **Multicast:** A multicast packet on the network originates from a single node and is received by a group of nodes. Multicast addressing is often used for collaboration, real-time multimedia and multipoint file transfers. Multicast communication is often referred to as one-to-many communication.

IP Multicast is an extension of IP to allow for efficient group communication. Receivers join a specific multicast group and this specific group is assigned a single IP address. Any message addressed to the group IP address will be received by all the members in the group.

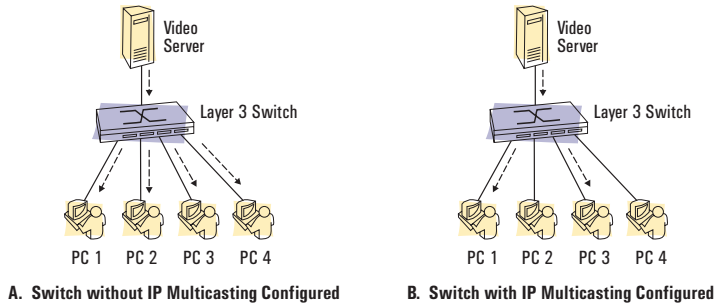

In the above picture, PCs 1 and 3 belong to an IP multicast group called video clients; they are the only PCs on this network that need to receive data from the video server. All four of the PCs in Figure 1A, however, receive video packets because the switch is not configured for IP multicasting—the switch does not differentiate IP multicast group members from non-group members. The switch in figure 1B is configured for IP multicasting, and only those PCs in the video clients group (PCs 1 and 3) receive the data from the video server. The switch in figure 1B is much more efficient in eliminating unnecessary traffic.

Multicasting is very efficient: the originating node does not have to maintain a list of members and a node can be easily added or deleted from a group.

To support IP multicast, the sending node, receiving node, and network infrastructure must be multicast-enabled. HP Layer 3 switches supports IP Multicasting and IP Multicasting with Priority Queuing to easily handle IP Multicast applications. HP Layer 3 switches:

- Discover IP multicast clients and servers using the Internet Group Management Protocol (IGMP)
- Distinguish between different multicast streams (channels)
- Forward multicast packets using ASIC forwarding. Refer to the Switching Technology section of this guide for further information on ASIC forwarding.
- Block flooding of multicast streams to ports with no multicast members
- Provide increased priority for multicast streams to maintain Quality of Service over Ethernet
- Comply to industry standards

How can you sell the **Supports Multicast Applications** feature of proactive networking? Your network administrators will be able to manage network growth and control costs. Upgrading to multicast applications reduces the load on the server, which no longer needs to send out multiple copies of a message as required with unicast-addressed communication. Network administrators asking for applications such as multimedia, whiteboard sharing, and large database transfers will take advantage of multicast applications and the hardware needed to support multicasting.

## Supports Multiport Trunking

"I need to increase the bandwidth of my network while minimizing cost and complexity of my network."

Get gigabit performance without the expense of gigabit hardware with multiport trunking. Multiport trunking allows you to connect two HP layer 3 switches with multiple links that act as one high-bandwidth link. The performance of your network is enhanced without the addition of high-speed hardware.

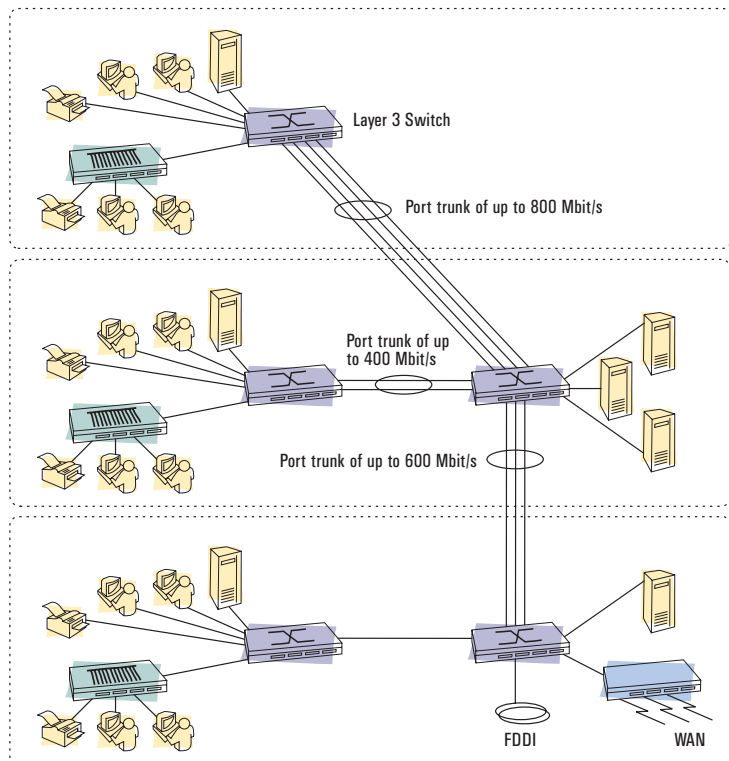

The above picture shows how you can increase the bandwidth of your network by setting up multiport trunking. By enabling port trunking, the link between switch 1 and switch 2 can be up to 800Mbps.

### Port trunking:

- Increases bandwidth between two switches, without the added complexity of high-speed equipment.
- Provides redundant links between two switches, adding to the security of the network.
- Allows you to distribute switches, workgroups, and servers without losing performance.

How can you sell the **Supports Multiport Trunking** feature of proactive networking? What network administrator can resist better performance without the added cost and complexity of high-speed devices? Recommend port trunking and your customers will realize increased performance can be implemented with HP proactive networking.

---

## Provides Industry-Leading Support

*"My business relies on the network. Networking equipment is inherently reliable. What is important to me is how the vendor acts when something breaks."*

You and your customers get the benefit of HP's unrivaled quality and reliability. HP backs its products with end-user telephone support. HP's best-in-the-industry warranty covers products for lifetime (for as long as you own the product), getting replacement parts to you fast, with next-business-day advance replacement, where available.

---

## HP Proactive Networking

Managed HP hubs and switches with HP proactive networking let you leave much of your network troubleshooting and diagnosing to HP. You can sleep easy knowing that the HP proactive networking helps to ensure that your network remains healthy, that you can quickly detect and identify potential problems, and that you have a recommended action plan. You also know that with an easy-to-access Web browser, you can get information about your devices anywhere, any time. HP helps you take the work out of networking.

For more information on HP proactive networking, visit the HP networking Reseller Plaza website.



<http://www.hp.com/key/netreseller>



# Chapter 3: Analyzing Your Customers

---



<http://www.hp.com/key/netreseller>

Refer to chapter 1 for more information about HP proactive networking design tool and HP Network DesignCenter. You can also visit the HP network reseller website, Reseller Plaza at: <http://www.hp.com/key/netreseller>

The first step in developing a successful network design is acquiring information about your customer. Hewlett-Packard has developed tools that can assist you with network consulting. Use HP proactive networking design tool to get design recommendations and generate a bill of materials. To access HP proactive networking design tool, visit the Reseller Plaza website.

HP proactive networking design tool provides a quick way to generate a network design and quote. If more complex designs are needed, call on your HP network contact. If you do not have an HP contact, please visit the <http://www.hp.com/key/netreseller> website.

The HP Network DesignCenter and your HP sales force team are ready to assist you in selling and supporting networks.

---

## Information Gathering

Most clients already have a network installed—gather everything you can about their network. You will need the following information to design a network:

- your client's current business problems
- the current physical network map
- applications currently in use
- applications planned for the future
- current LAN usage model (what's working and what's not working)
- internet connection
- network management needs
- relationships with current vendors

---

## The Current Physical Network Map

One of the most important things that you can acquire from your client is the network map. Use the network map to determine your client's existing hardware topology. Identify:

- Number of nodes on the network.
- Number of workgroups on the network.
- Number of servers on the LAN.
- Physical location of the servers. Are they centrally located or distributed?

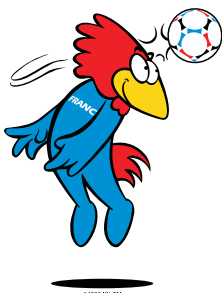



- Types of servers. Any legacy servers (such as a VAX or System 38 servers)?
- Number and location of wiring closets. If multiple wiring closets, how are the wiring closets connected to each other?
- Location and distances between campuses and other buildings
- Types of cable used in the LAN. Is coaxial cable installed, is the twisted-pair cable Category 3 or Category 5?
- Distance of each wiring run, especially the runs from the server room.

Anticipate network growth. Remember, each device on the LAN (PC, server, print server, network scanner, network analyzer, etc.) requires an additional port on the hub or switch.

---

## Current and Future Applications

The applications used by your clients will affect network optimization. To better design a network, characterize the traffic flow of each application. Answer the following questions:

- Are the applications used by your client local (PC)-based or server-based?
- Is the traffic bursty (intermittent) or frequent and constant?
- Do your clients typically transfer small files (less than 1 Mbyte) or large files (more than 1 Mbyte)?
- Do your clients always save files on a server?
- Do your client's applications require guaranteed bandwidth?
- What are the current and future security requirements?
- What is the uptime requirements of the network?

Future growth is an important consideration in designing a network. Anticipate new applications—and determine how new applications will affect the network usage.

---

## Current LAN Usage Model (what's working and what's not working)

Analyze your client's needs and determine areas of concern. Characterize traffic flow on the network—determine what clients use what servers and when peak times occur. A network management software tool, such as Hewlett-Packard's AdvanceStack Assistant for Resellers may help you determine the current state of the network. When characterizing traffic flow, be sure to forecast the effect of future growth. Adding users to the network and/or adding new applications can significantly affect network performance.

Use HP AdvanceStack Assistant for Resellers to help measure LAN usage.

---

## Internet Connection

Many clients are connecting to the Internet and will look to you for help. Determine your client's Internet needs. Does the client want to use an Internet Service Provider's equipment or are they going to provide their own equipment? When designing your client's network, be sure to include access to the Internet.

---

## Network Management Needs

Network management is an invaluable tool to analyze an existing network. Use HP AdvanceStack Assistant for Resellers to help you get valuable information about your customer's network. HP AdvanceStack Assistant for Resellers collects network data, and produces precise, detailed recommendations for the most cost-effective way to upgrade your customer's network. Use it to help collect information about traffic flow and traffic patterns. Potential network problems such as intermittent traffic congestion and overall network overload can be monitored and corrective actions, such as adding additional network hardware, can be recommended. The data gathered by network management can be used to help justify your recommendations. Proactive changes to the network can also be made by continually gathering information about the performance of the network.



# Chapter 4: Solution Topologies

---

<b>Building the LAN</b> .....	4-3
10Mbps Connections: 5–50 Nodes .....	4-6
10Mbps Connections: 50–200 Nodes .....	4-10
10Mbps Connections: 200–1000 Nodes .....	4-14
High-Speed Connections: 5–50 Nodes .....	4-18
High-Speed Connections: 50–200 Nodes .....	4-22
High-Speed Connections: 200–1000 Nodes .....	4-26
Guaranteed-Bandwidth Connections: 5–50 Nodes .....	4-30
Guaranteed-Bandwidth Connections: 50–200 Nodes .....	4-34
Guaranteed-Bandwidth Connections: 200–1000 Nodes .....	4-38
<b>Adding Internet Connectivity</b> .....	4-42
<b>Connecting Remote Sites</b> .....	4-45



In chapter 3, “Analyzing Your Customers”, the type of information you need to gather to effectively prescribe a network topology for your customer was provided. In this chapter, various network topology types are presented. You can combine your knowledge of your customer from your analysis, with the information provided in this chapter, and select a network topology type that meets your customer’s business needs.

For each topology in this chapter, a basic description is provided, followed by a drawing of the topology. This is followed by a shopping list table which describes each of the networking devices used in the topology and provides page references for the location in this document for more product-specific information. Finally, more detailed information is provided on the topology including:

- building the workgroup
- advantages
- design notes
- network monitoring and management
- Internet and remote office access
- upgrading existing 10Base-T workgroups
- expanding the workgroup

Each topology provides information both for customers who do not yet have a network and for those who are adding components onto an existing network for a growing business. This chapter covers the following three networking topics:

- Building the LAN
- Adding Internet Connectivity
- Connecting Remote Sites

We’ll discuss how to build the customer’s LAN below. The Internet access and remote office connectivity discussions are later in this chapter.

# Building the LAN

As described in chapter 3, analyzing your customer's needs is the basis of making the right choices for their network. This chapter will help you make the network technology recommendations for their network. You must provide answers to the following questions:

- *How many network nodes are in your customer's LAN?*  
The number of nodes have been separated into three categories:
  - 5–50 nodes
  - 50–200 nodes
  - 200–1000 nodes
- *What types of applications are your customers using?*  
Applications determine network use. Patterns emerge as users work throughout the day. Knowing these patterns, and planning for future network use, can help determine the network technology best suited for your customer.

The rest of this section helps you answer these questions and then directs you to the other sections in this chapter that provide recommended network topologies based on the answers to these questions.

## Determine the number of nodes in your customer's network

The number of nodes in your customer's network will help determine the network type and complexity of the network. Look in the following table to determine the range of the number of nodes in the customer's network, including PCs and workstations, printers and other peripheral devices. Don't forget to factor network growth. Does your customer have plans to add additional nodes, wiring closets and servers? Determine the number of anticipated nodes and continue to "select the type of connection".

 Determine number of nodes in your network.

**Table 4-1. Determining Size of Network**

Number of Nodes (servers, PCs, printers, etc.)	Typical Number of Wiring Closets	Typical Number of Servers
5–50 Nodes	1	1–5
50–200 Nodes	1–3	2–10
200–1000 Nodes	3–10 or more	10 or more

**Note:** 1000 nodes is used as the maximum size here because that is the typical maximum size for a business building. Networks of more than 1000 nodes can be built by simply multiplying and combining the network designs in this chapter and connecting the buildings together with fiber-optic cabling.

 Select the type of connection based on the applications being used.

**To determine connection type, select the type of application your customers use**

By determining the applications being run on the network, you can determine the type of network technology needed to connect desktops and servers to the network. The following table defines three main types of application classes, each of which has different network traffic characteristics. Determine the type of application that best describes your customer. Select the type of connection prescribed by the application type and proceed to the “selecting the topology” section.

**Table 4-2. Determining Type of Application**

Applications	Traffic Characteristics	Type of Connection
<ul style="list-style-type: none"> <li>• Typical off-the-shelf PC-based programs</li> <li>• Email</li> <li>• Word processing</li> <li>• Spreadsheets</li> <li>• PC-based database</li> <li>• Black and white printing</li> </ul>	<ul style="list-style-type: none"> <li>• Local (PC-based) processing</li> <li>• Intermittent network use (bursty traffic)</li> <li>• Smaller files (less than 1 Mbyte) being transferred</li> </ul>	10Mbps Connection
<ul style="list-style-type: none"> <li>• CAD/CAM</li> <li>• Online transaction processing (OLTP)</li> <li>• Image processing</li> <li>• Color printing/plotting/scanning</li> <li>• Web access and/or presence</li> <li>• Network computers (diskless)</li> <li>• Frequent file sharing via a file server</li> <li>• Large database such as Oracle, Sybase</li> <li>• Three-tiered client/server (SAP R/3)</li> </ul>	<ul style="list-style-type: none"> <li>• Server-based processing</li> <li>• Frequent and consistent network use</li> <li>• Larger files (greater than 1 Mbyte)</li> <li>• Quick response time needed</li> </ul>	High-Speed Connection
<ul style="list-style-type: none"> <li>• Video</li> <li>• Time sensitive applications</li> <li>• Video conferencing</li> <li>• White boarding</li> <li>• Remote training</li> <li>• Internet phone</li> </ul>	<ul style="list-style-type: none"> <li>• Guaranteed bandwidth to ensure smooth image display</li> <li>• Consistent fast response time</li> <li>• Delay/latency sensitive</li> <li>• Constant, streaming data</li> </ul>	Guaranteed-Bandwidth Connection

As shown in the table, there are three types of connections, based on the applications your customers most commonly use.

- **10Mbps:** The first one, the 10Mbps Connection, is for customers who use the most common applications, such as email and word processing, in today’s small businesses and workgroups.
- **High-Speed Connection:** When the customer’s workgroup expands its applications to include Web access, heavy database use, and CAD/CAM applications, they may need to upgrade to a High-Speed Connection. High speed is needed for Web access so that users do not have to wait for web pages to load file transfers to finish.
- **Guaranteed Bandwidth:** With the popularity of the Internet, the customer can try out the new Internet applications such as video conferencing and video phone. These applications require uninterrupted use of the LAN. For these types of applications, the customer will need a Guaranteed-Bandwidth Connection.

## Determine the topology model for your customer

Nine different topologies are included in this chapter, as seen in figure 4-1. Depending on your customer's node count and type of connection, you will be asked to go a specific topology, as referenced by the page number in table 4-3. There you will find a description of the topology, followed by a drawing of the topology. Also included is a shopping list table, and more information to help you sell and support this topology.

*Using the node count and the type of connection, determine your topology.*

Figure 4-1. Various Recommended Topologies

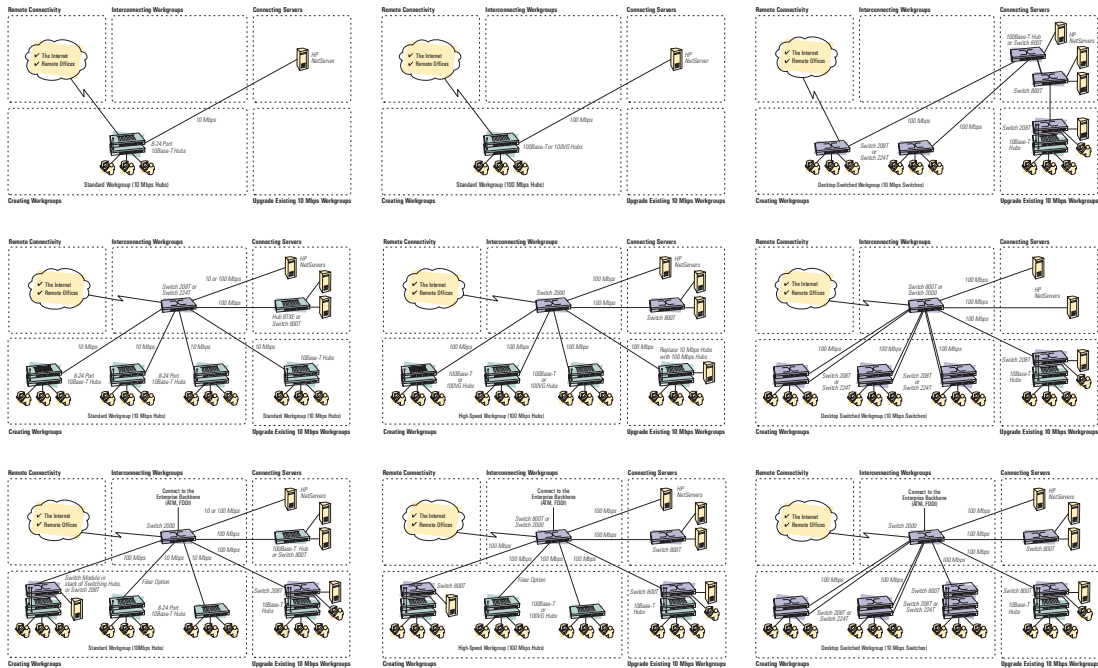

To determine the recommended topology, use the table below. The table gives you the page where information on that topology can be found.

Table 4-3. Selecting the Topology

Node Count	Type of Connection		
	10Mbps Connection	High-Speed Connection	Guaranteed-Bandwidth Connection
5–50 users	page 4-6	page 4-18	page 4-30
50–200 users	page 4-10	page 4-22	page 4-34
200–1000 users	page 4-14	page 4-26	page 4-38



## 10Mbps Connections: 5–50 Nodes

*Use this model if you want to connect a small, standalone workgroup.*

A network of this size is a standalone network for an independent office or business that may or may not include Internet access or remote access. It is a single workgroup (segment) and uses 10Base-T hubs and 10Base-T LAN adapters (NICs). The server(s), PCs, and printer(s) attach directly to the hubs. The network may have only one server, and there is little or no need for network management beyond observing the LEDs on the network devices.

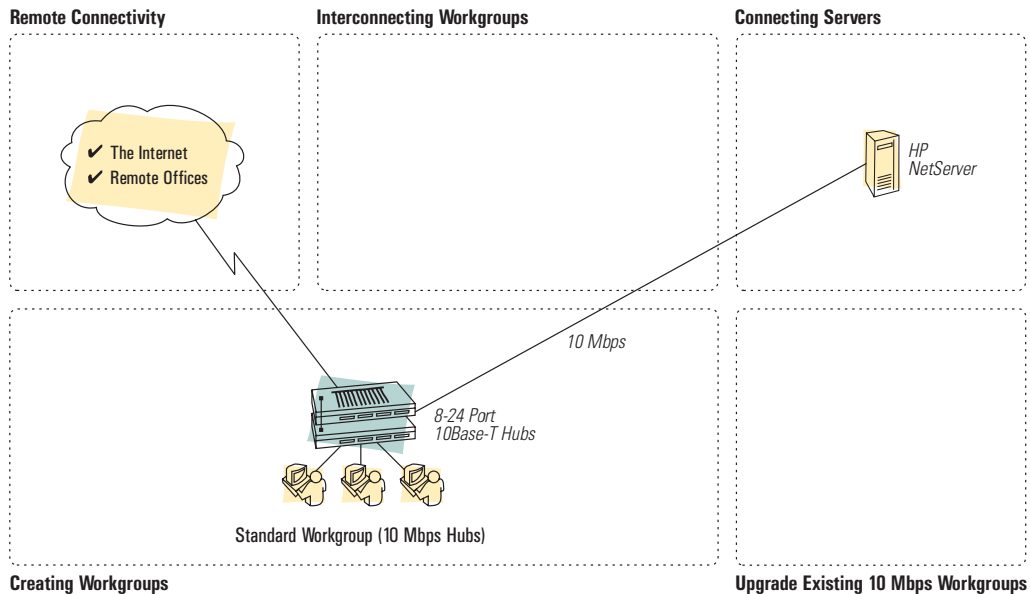

### Shopping List

Product in the Topology	Product Number	Descriptions	Page
10Base-T hubs with expansion slot: <ul style="list-style-type: none"> <li>• Hub-12R</li> <li>• Hub-24R</li> <li>• Hub-24T</li> </ul>	<ul style="list-style-type: none"> <li>• HP J3200A</li> <li>• HP J3202A</li> <li>• HP J3204A</li> </ul>	12- and 24-port 10Base-T port-switching hubs with expansion slots for adding the Internet Router Module and an SNMP management module.	<ul style="list-style-type: none"> <li>• 5-36</li> <li>• 5-36</li> <li>• 5-36</li> </ul>
10Base-T hubs without expansion slot: <ul style="list-style-type: none"> <li>• Hub-8E</li> <li>• Hub-8U</li> <li>• Hub-16U</li> <li>• Hub12</li> <li>• Hub 12M</li> <li>• Hub 24</li> <li>• Hub 24M</li> </ul>	<ul style="list-style-type: none"> <li>• HP J3128A</li> <li>• HP J2610B</li> <li>• HP J2611B</li> <li>• HP J3300A</li> <li>• HP J3301A</li> <li>• HP J3302A</li> <li>• HP J3303A</li> </ul>	Very low cost 10Base-T hubs. The 8U and 16U have a slot for adding an SNMP management module.  Low cost, unmanaged 10Base-T 12-port hub. Low cost, managed 10Base-T 12-port hub Low cost, unmanaged 10Base-T 24-port hub. Low cost, managed 10Base-T 24-port hub	<ul style="list-style-type: none"> <li>• 5-26</li> <li>• 5-26</li> <li>• 5-26</li> <li>• 5-26</li> <li>• 5-26</li> <li>• 5-26</li> <li>• 5-26</li> </ul>
Remote connectivity: <ul style="list-style-type: none"> <li>• Internet Router Module</li> <li>• Internet Router/Remote 2C Bundle</li> </ul>	<ul style="list-style-type: none"> <li>• HP J3138A</li> <li>• HP J3231A</li> </ul>	Use these products if Internet access or remote office connectivity is needed by your network.	<ul style="list-style-type: none"> <li>• 5-40</li> <li>• 5-40</li> </ul>

**Building the Workgroup: Shared 10Base-T.** Unless there will be a high demand on server links, 10Base-T technology should serve the needs of this network. This network is a single workgroup (segment) consisting of a hub, or a small number of hubs connected together. Category 3 or better unshielded twisted-pair cable (UTP) would likely be used for all connections. Fiber-optic cable would generally not be needed because the distances involved are not expected to require it. This technology offers:

- More than adequate bandwidth and speed for the types of applications being used in this category.
- A cost-effective, widely-used solution with a flexible choice of hubs. Hubs selected will depend on node count, expected growth, and whether Internet or remote office access is needed.

Standalone 10Base-T networks of this type can be planned to easily accommodate future network expansion or technology upgrades.

**Advantages.** This type of network offers a simple, well-understood approach that eliminates any complexity in the installation or configuration. It offers these types of advantages:

- low equipment and installation costs
- no configuration is required—the devices can be connected together and used almost immediately
- a single wiring closet can accommodate all networking devices

#### Design Notes.

- This is generally a standalone network, not intended for connection to a larger enterprise LAN, although that could be easily accomplished.
- The maximum distance from the hub to each of the end nodes is 100 meters for Category 3 UTP cable. Greater distances can be accommodated with Category 5 or better cable.
- A higher-speed performance upgrade (converting to 100Base-T in the future) will require replacing the 10Base-T network adapters (NICs). However, if upgrading to 100Mbps technology is expected in the near future, then design the network for expansion and install 10/100Mbps NICs where they will be needed when the time comes to upgrade.

**Network Monitoring and Management.** Using the hub LEDs to verify proper connections and for troubleshooting is likely to be the only network management activity in this type of LAN. Network management software, such as HP AdvanceStack Assistant (ASA), isn't likely in this application because the network is not large enough to really warrant its use.

However, if more complex applications are added later, you can add an optional SNMP module to most of the hubs listed in the table above to upgrade the hubs for network monitoring and management (with ASA software included at no extra cost).

Applications in this office use the network on an intermittent basis, and require a low-cost network solution. Common applications include:

- Email
- Word processing
- Spreadsheets
- PC-based data bases (such as SQL)
- Basic (non-color) printing

Traffic characteristics include:

- Local processing
- Intermittent (bursty) network use
- Smaller files (<1 MB) being transferred

### **Internet and Remote Office Connections.**

To add Internet access to this workgroup, the recommended solution is to create an “open” subnet that has an HP Remote 2C/Internet Router Bundle, which provides the connectivity to the Internet. This open subnet is then connected to the office network through a server configured as a firewall router to provide security.

To add remote office connectivity to this workgroup, the recommended solution is to use the switching hubs: HP AdvanceStack Hub-12R, Hub-24R, or Hub-24T, in the initial workgroup installation and later add the optional HP Internet Router Module to one of the hubs. Otherwise, the solution is to use the HP Remote 2C and Internet Router Bundle in the network, which includes the Internet Router Module. The Internet Router Module provides the remote connectivity for site-to-site connections.

For more information on Internet and remote office access, refer to “Adding Internet Connectivity” on page 4-42 and “Connecting Remote Sites” on page 4-45.

**Expanding the Workgroup.** Expected expansion for the 10Mbps connectivity network may include:

- Introducing more complex and network-intensive applications, which affect traffic characteristics and create a need for high-speed performance (pages 4-18 to 4-29) or guaranteed-bandwidth capability (pages 4-30 to 4-41).
- Adding more hubs to provide ports for more PCs, servers, and/or printers, and possibly adding another wiring closet to meet the expanding connectivity needs.
- Adding Internet connectivity or remote office connectivity after initial installation, as described above.



## 10Mbps Connections: 50–200 Nodes

*This is the model for your remote site, or a medium-sized standalone workgroup.*

A network of this size is either a remote office connected to a central site, a small central site with remote offices connected, or a medium-sized standalone network. Because of the number of nodes, dividing the network into multiple segments is recommended to reduce congestion problems. The PCs and printers attach directly to the hubs. Servers attach to one or more hubs and also to the segment switch. Use of HP AdvanceStack Assistant is recommended for network management.

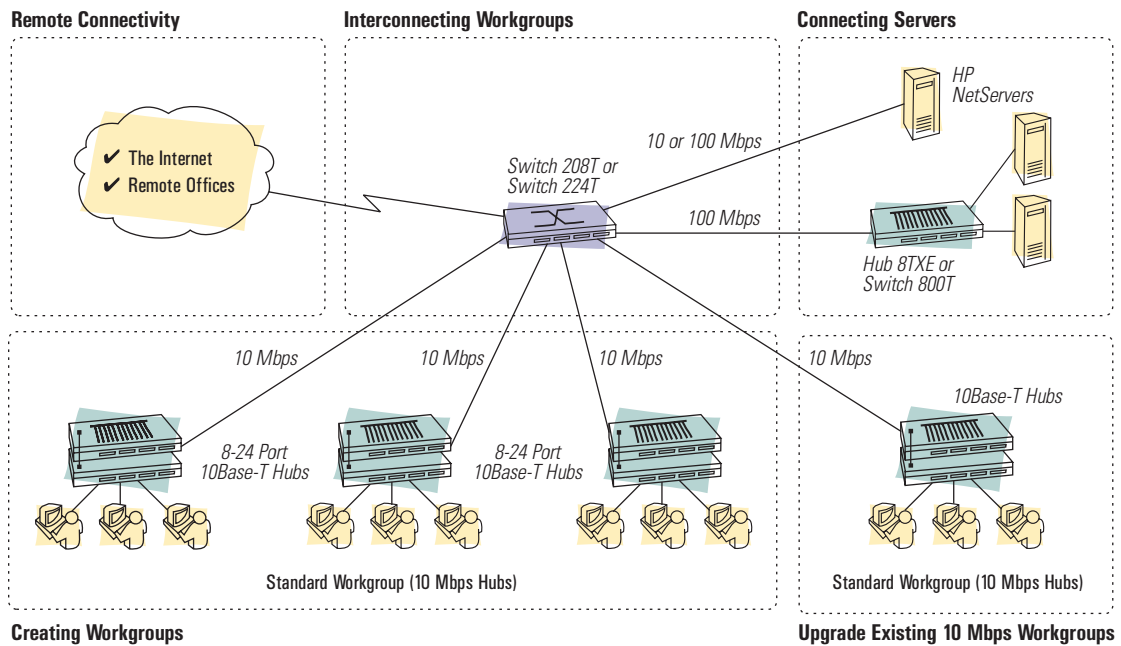

### Shopping List

Product in the Topology	Product Number	Descriptions	Page
Workgroup switches:			
• Switch 208T	• HP J3175A	8- and 24-port 10Base-T switches; two 100Mbps uplinks; expansion slots for Internet Router and SNMP module.	• 5-18
• Switch 224T	• HP J3177A		• 5-18
Interconnect switch:			
• Switch 800T	• HP J3245A	Has 8 transceiver slots for HP 100Base-TX or -FX transceivers.	• 5-14
100Base-T hub:			
• Hub-8TXE	• HP J3235A	An 8-port 100Base-TX hub.	• 5-30
10Base-T hub with expansion slot:			
• Hub-12R	• HP J3200A	12- and 24-port 10Base-T port-switching hubs with expansion slots for adding the Internet Router Module and an SNMP management module.	• 5-36
• Hub-24R	• HP J3202A		• 5-36
• Hub-24T	• HP J3204A		• 5-36

Product in the Topology	Product Number	Descriptions	Page
10Base-T hub without expansion slot:			
• Hub-8E	• HP J3128A	Very low cost 10Base-T hubs. The 8U and 16U have a slot for adding an SNMP management module.	• 5-26
• Hub-8U	• HP J2610B		• 5-26
• Hub-16U	• HP J2611B	Low cost, unmanaged 10Base-T 12-port hub.	• 5-26
• Hub12	• HP J3300A		• 5-26
• Hub 12M	• HP J3301A	Low cost, managed 10Base-T 12-port hub	• 5-26
• Hub 24	• HP J3302A	Low cost, unmanaged 10Base-T 24-port hub.	• 5-26
• Hub 24M	• HP J3303A	Low cost, managed 10Base-T 24-port hub	• 5-26
Remote connectivity:			
• Internet Router Module	• HP J3138A	Use these products if Internet access or remote office connectivity is needed by your network.	• 5-40
• Internet Router/Remote 2C bundle	• HP J3231A		• 5-40

### Building the Workgroup: Shared 10Base-T with Switching

**Between Segments.** This is a cost-effective, widely-used solution with a flexible choice of hubs. It is comprised of multiple versions of the 5–50 node 10Mbps network interconnected through the Switch 208T or 224T workgroup switch. Each workgroup is a single 10Base-T segment consisting of 1 to a few hubs connected together. The characteristics of this network are:

- Simple shared 10Base-T twisted-pair technology provides the primary connections within segments in this network. Both 10Base-T and 100Base-T LAN adapters (NICs) have a role in this network; 10Base-T in the desktop PCs, and 100Base-T in the servers.
- The workgroup switch connects the segments together and should have 100Mbps ports for connecting the servers.

This network may have multiple servers, but bandwidth requirements may not warrant a dedicated 100Mbps port per server. (Using a 100Mbps hub to connect the servers together and to the switch is adequate if the number of 10Mbps segments connected to the central workgroup switch is low.) If there are several servers or increased traffic between servers, it may be more cost-effective to use a Switch 800T to concentrate servers together, then connect the 800T to the workgroup switch. By enabling full-duplex operation on the 800T and the server LAN adapters, you can achieve up to 200Mbps of bandwidth per connection.

- Separating the network into multiple smaller segments reduces traffic among the segments and the servers.
- Because SNMP management should be used with this network, include an HP J3178A Management Module with the workgroup switch you choose.

#### Advantages.

- low start-up cost
- very little configuration needed, if any
- easy expansion to more ports and servers
- low-cost access to servers without needing more switch ports (by connecting the servers to a 100Base-T hub)

Applications in this office use the network on an intermittent basis and require a low-cost network solution. Common applications include:

- Email
- Word processing
- Spreadsheets
- PC-based databases (such as SQL)
- Basic (non-color) printing

Traffic characteristics include:

- Local processing
- Intermittent (bursty) network use
- Smaller files (<1 MB) being transferred

### Design Notes.

- Adding segments and/or servers may increase traffic to the point where another workgroup switch will be needed to reduce congestion. A 100Mbps hub (or placing some individual servers on dedicated segments) will be needed to reduce congestion.
- If the network design requires the use of multiple wiring closets, the distance between wiring closets may require a fiber link to connect them together. Depending on the distance between wiring closets, there may be a need to use a fiber link between a hub and the segment switch. In this case, the topology design should place the switch where it can use UTP cable for links to as many hubs as possible. The illustrated solution supports a single fiber connection to the segment switch. If more than one fiber connection to the segment switch is needed, turn to the “10Mbps Connection: 200–1000 Nodes” on page 4-14.

**Network Monitoring and Management.** The customers should monitor the network traffic to help determine the most effective ways to organize the users into the network segments and to locate the servers. HP AdvanceStack Assistant (ASA) network monitoring and management software (included at no extra cost with workgroup switches) provides easy-to-use network monitoring tools.

**Internet and Remote Office Connections.** To add Internet access to this workgroup, the recommended solution is to create an “open” subnet that has an HP Remote 2C/Internet Router Bundle, which provides the connectivity to the Internet. This open subnet is then connected to the office network through a server configured as a firewall router to provide security.

To add remote office connectivity to this workgroup, the recommended solution is to use either the Switch 208T or Switch 224T as the workgroup switch and install the optional HP Internet Router Module into the expansion slot in the switch. Otherwise, the solution is to use the HP Remote 2C and Internet Router Bundle in the network, which includes the Internet Router Module. The Internet Router Module provides the remote connectivity for site-to-site connections.

For more information on Internet and remote office access, refer to “Adding Internet Connectivity” on page 4-42 and “Connecting Remote Sites” on page 4-45.

**Upgrading from a Single 10Base-T Workgroup.** Adding more users to an existing workgroup (single segment) may cause congestion. When this occurs, the network should be divided into multiple workgroups by connecting the users to different hubs, then connect the hubs together through a workgroup switch. This design is the essence of the topology described in this section.

**Expanding the Workgroup.** Expected expansion for this network includes:

- Introducing more complex and network-intensive applications, which affect traffic characteristics and create a need for high speed performance (pages 4-18 to 4-29) or guaranteed-bandwidth capability (pages 4-30 to 4-41).
- Adding more 10Base-T hubs:
  - Connected within a segment to increase the number of nodes in the segment.  
  
If you have used the Hub-12R, Hub-24R, or Hub-24T to build your network, up to 8 of these hubs can be stacked together through their stacking ports. These stacked hubs form a larger single workgroup.  
  
If you are connecting the hubs together through the RJ-45 ports (cascading), up to 5 hubs can be connected together in this way, according to the IEEE 802.3 Type 10Base-T standard.
  - Connected to the workgroup switch to increase the number of segments.
- Adding more servers, and possibly creating another server farm by adding another 100Mbps hub and connecting it to the workgroup switch. Or, if traffic to the servers is very heavy, connect the servers together by a Switch 800T, which provides a dedicated 100Mbps bandwidth to each server. Then, connect the Switch 800T to the workgroup switch.
- Adding another wiring closet to expand the network and support further segmentation.



## 10Mbps Connections: 200–1000 Nodes

*Use this model to network your central office.*

A network of this size is likely to be the central site, with several smaller remote sites. You will likely need Internet access and will have a variety of server performance needs. Several wiring closets will be needed with the flexibility to use fiber between closets. An experienced network management staff is needed for network monitoring and management.

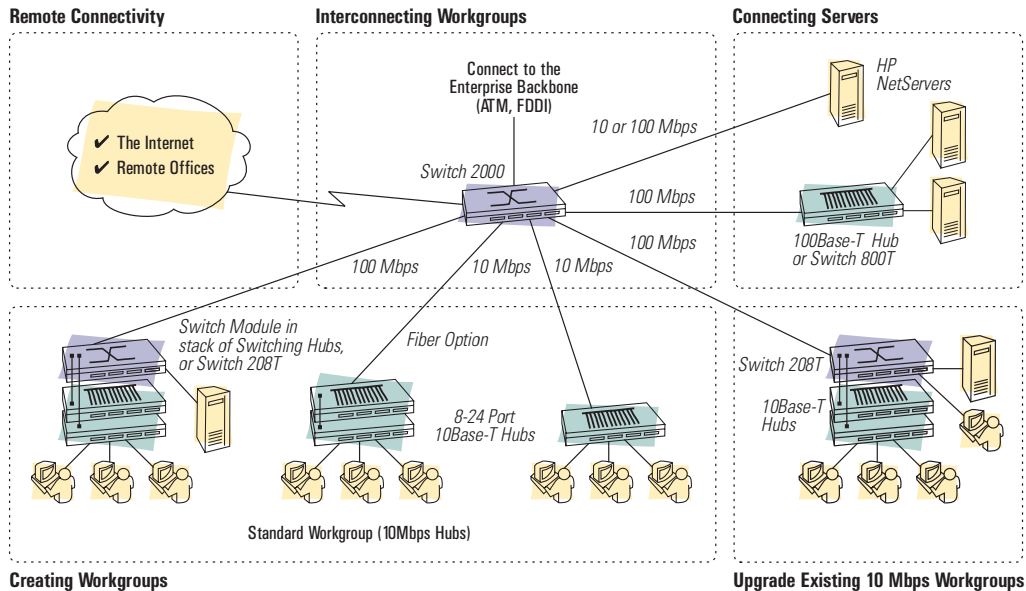

### Shopping List

Product in the Topology	Product Number	Descriptions	Page
Interconnect switches:			
• Switch 2000	• HP J3100B	The 2000 is a 6-slot switch for 10Base-T, 10Base-FL, 100Base-T, 100VG, FDDI, and ATM modules. The 800T has 8 transceiver slots for HP 100Base-TX or 100Base-FX transceivers.	• 5-10
• Switch 800T	• HP J3245A		• 5-14
Workgroup switches:			
• Switch 208T	• HP J3175A	8 and 24-port 10Base-T switches with two 100Mbps uplinks & expansion slots for adding Internet Router & SNMP module.	• 5-18
• Switch 224T	• HP J3177A		• 5-18
10Base-T hubs with expansion slot:			
• Hub-12R	• HP J3200A	12- and 24-port 10Base-T port-switching hubs with expansion slots for adding the Internet Router Module and an SNMP management module.	• 5-36
• Hub-24R	• HP J3202A		• 5-36
• Hub-24T	• HP J3204A		• 5-36
10Base-T hubs without expansion slot:			
• Hub-8E	• HP J3128A	Very low cost 10Base-T hubs. The 8U and 16U have a slot for adding an SNMP management module.	• 5-26
• Hub-8U	• HP J2610B		• 5-26
• Hub-16U	• HP J2611B		• 5-26
• Hub 12	• HP J3300A	Low cost, unmanaged 10Base-T 12-port hub.	• 5-26
• Hub 12M	• HP J3301A	Low cost, managed 10Base-T 12-port hub	• 5-26
• Hub 24	• HP J3302A	Low cost, unmanaged 10Base-T 24-port hub.	• 5-26
• Hub 24M	• HP J3303A	Low cost, managed 10Base-T 24-port hub	• 5-26

Product in the Topology	Product Number	Descriptions	Page
100Base-T hubs: <ul style="list-style-type: none"> <li>• Hub-8TXE</li> <li>• Hub-12TX</li> <li>• Hub-12TXM</li> <li>• Hub-24TX</li> </ul>	<ul style="list-style-type: none"> <li>• HP J3235A</li> <li>• HP J3233A</li> <li>• HP J3234A</li> <li>• HP J3272A</li> </ul>	100Base-TX hubs with 8, 12 or 24 RJ-45 ports. The Hub-12TXM includes SNMP management.	<ul style="list-style-type: none"> <li>• 5-30</li> <li>• 5-30</li> <li>• 5-30</li> <li>• 5-30</li> </ul>
Remote connectivity: <ul style="list-style-type: none"> <li>• Internet Router Module</li> <li>• Internet Router/Remote 2C bundle</li> </ul>	<ul style="list-style-type: none"> <li>• HP J3138A</li> <li>• HP J3231A</li> </ul>	Use these products if Internet access or remote office connectivity is needed by your network.	<ul style="list-style-type: none"> <li>• 5-40</li> <li>• 5-40</li> </ul>

**Building the Workgroup: Shared 10/100Base-T with Switching Between Segments.** This cost-effective solution uses a flexible choice of hubs to form workgroups supported by workgroup switches, such as the Switch 800T. It is comprised of multiple versions of the 50–200 node 10Mbps network connected together by an interconnecting switch. By interconnecting several segment switched networks in this way, networks of 1000 or more nodes can be formed. The characteristics of this network are:

- Workgroup PCs and printers are connected to 10Base-T hubs.
- To reduce congestion and control unnecessary workgroup traffic:
  - Workgroup switches enable multiple segments, which are connected together by a segment switch such as the Switch 2000 or the Switch 800T.
  - Dedicated servers or servers having greater bandwidth needs are supported by full-duplex connections made directly to the switches.
  - Centralized servers that do not have bandwidth needs requiring a dedicated link are connected to 100Mbps hubs to form server farms.
- 10Base-T workgroup switches with at least two 100Mbps ports support large or multiple floors. These switches also support servers dedicated to specific workgroups.
- A 10/100Mbps segment switch interconnects all segments and the centralized servers, and provides the links for remote office connectivity and Internet access. This interconnect switch can support ports at both 10Mbps and 100Mbps. This switch also controls traffic in a scaleable way and provides levels of fault tolerance.

To accommodate a variety of distances, the switches offer both twisted-pair and fiber media options.

Applications in this office use the network on an intermittent basis and require a low-cost network solution. Common applications include:

- Email
- Word processing
- Spreadsheets
- PC-based data bases (such as SQL)
- Basic (non-color) printing

Traffic characteristics include:

- Local processing
- Intermittent (bursty) network use
- Smaller files (<1 MB) being transferred

**Advantages.** This topology offers flexible speed and media options in networks where the applications do not require high-speed or guaranteed-bandwidth connections. The centralized servers meet a variety of speed requirements.

- isolates distributed servers from unnecessary network traffic
- provides local 100Mbps bandwidth for distributed servers
- provides fiber connectivity at both 10Mbps and 100Mbps
- allows easy expansion to more ports and servers
- optional SNMP management enables performance and network monitoring on all ports
- uses broadcast traffic control and layer 3 switching to enhance scalability and fault isolation

**Design Notes.** Adding segments and/or servers may increase traffic to the point where another 100Mbps hub (or placing some servers on dedicated segments) will be needed to reduce congestion.

**Network Monitoring and Management.** The customers should monitor the network traffic to help determine the most effective ways to organize the users into the network segments and to locate the servers. HP AdvanceStack Assistant (ASA) network monitoring and management software (included at no extra cost with the managed workgroup switches) provides easy-to-use network monitoring tools.

**Internet and Remote Office Connections.** To add Internet access, the recommended solution is to create an “open” subnet that has an HP Remote 2C/Internet Router Bundle, which provides the connectivity to the Internet. This open subnet is then connected to the office network through a server configured as a firewall router to provide security.

To add remote office connectivity to this network, the recommended solution is to use either the Switch 208T or Switch 224T as the workgroup switches and install the optional HP Internet Router Module into the expansion slot in the switch. Otherwise, the solution is to use the HP Remote 2C and Internet Router Bundle, which includes the Internet Router and the Remote 2C two-slot expansion cabinet. Then connect the cabinet to an available 10Base-T port on the interconnect switch in the same way as any other network device.

In a network of this size, a single remote connection for Internet or remote office communication may not be sufficient to handle all the traffic. The Internet Router Module has two WAN ports which can be used simultaneously to connect the network to the Internet.

For more information on Internet and remote office access, refer to “Adding Internet Connectivity” on page 4-42 and “Connecting Remote Sites” on page 4-45.

### Upgrading from Separate Standalone Networks.

Connecting multiple standalone networks together can cause congestion in the central environment. Also, distances between wiring closets may exceed the maximum allowed and require fiber-optic connections. The solution is to add either a Switch 2000 or a Switch 800T to connect standalone networks together. In this case:

- Use either a Switch 2000 or a Switch 800T.

The Switch 2000 connectivity (with optional modules and transceivers) offers:

- 10/100Mbps UTP and fiber connectivity
- port trunking for fault-tolerance and increased bandwidth
- modular options for FDDI or ATM connections to an enterprise backbone.

The Switch 800T offers:

- 10/100Mbps UTP connectivity; 100Mbps fiber connectivity
- port trunking for fault-tolerance and increased bandwidth

- Move existing dedicated servers to ports on the workgroup switches within segments to isolate them from the backbone and to provide parallel access. Ideally, connect all such servers to 100Mbps ports on the local workgroup switches.
- For central servers having lower bandwidth needs, create server farms by using a 100Mbps hub connected to the segment switch. Connect central servers needing dedicated bandwidth directly to the segment switch using 100Mbps links.
- Use the layer 3 switching capability in the Switch 2000 or Switch 800T to support network addressing and traffic needs.
- Depending on expected traffic demands, use either a 10Mbps or 100Mbps link between each workgroup switch and the central segment switch.

**Expanding the Workgroup.** Expected expansion for this network includes:

- Adding more 10Base-T hubs within existing segments to increase the number of nodes.
- Adding new workgroup switches to create new segments and reduce congestion within segments.
- Connecting more local or central servers, and possibly creating a new server farm by adding another 100Mbps hub.
- Adding another wiring closet to expand the network and support further segmentation.
- Introducing more complex and network-intensive applications, requiring upgrades from 10Base-T to 100Base-T or adding segments running 100VG technology.

The topology shown in this section effectively represents a single building. On a multi-building campus, a network like this can be built in each building. The buildings can then be connected together by connecting each of the interconnect switches to the campus backbone.

## High-Speed Connections: 5–50 Nodes

To connect a small, high-speed workgroup, use this model.

This is a small workgroup of high performance computers sharing a single 100Mbps segment. Users in this environment are running data intensive specialized applications that involve, for example, large file transfers, desktop publishing, CAD, or imaging. The need is to move megabytes of data in short periods of time; low file transfer times are critical. The access to the network is infrequent and unpredictable, but demanding. The network must not be a bottleneck.

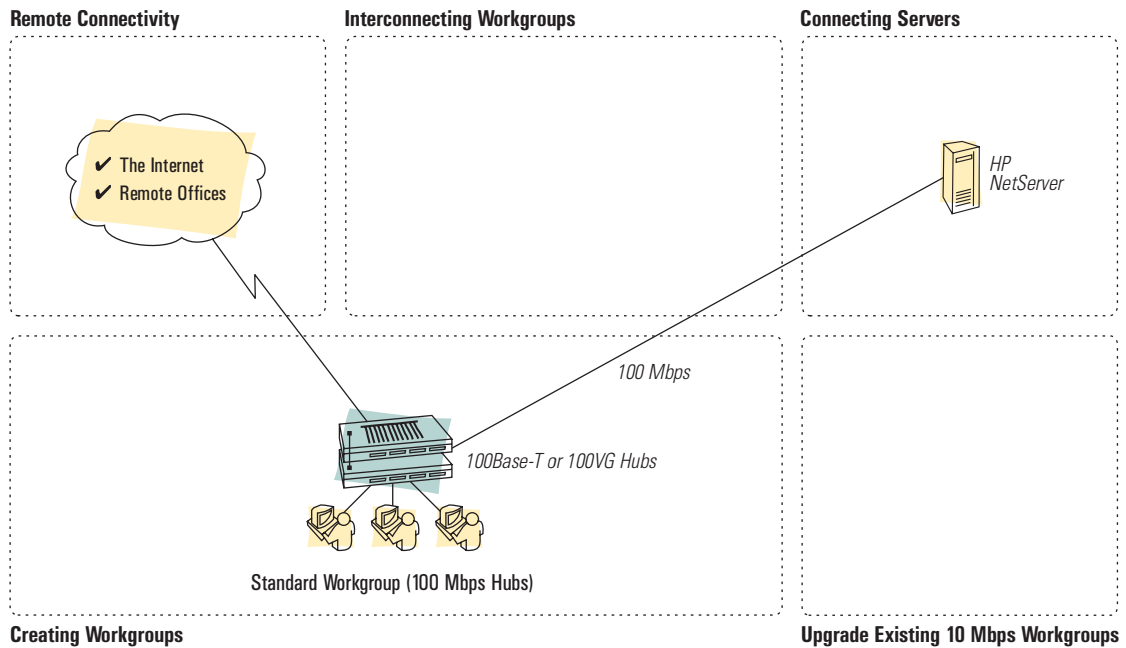

### Shopping List

Product in the Topology	Product Number	Descriptions	Page
100Base-T hubs: <ul style="list-style-type: none"> <li>• Hub-8TXE</li> <li>• Hub-12TX</li> <li>• Hub-12TXM</li> <li>• Hub-24TX</li> </ul>	<ul style="list-style-type: none"> <li>• HP J3235A</li> <li>• HP J3233A</li> <li>• HP J3234A</li> <li>• HP J3272A</li> </ul>	100Base-TX hubs with 8 and 12 RJ-45 ports. The Hub-12TXM includes built-in SNMP management.  100Base-TX hub with 24 RJ-45 ports	<ul style="list-style-type: none"> <li>• 5-30</li> <li>• 5-30</li> <li>• 5-30</li> <li>• 5-30</li> </ul>
100VG hubs: <ul style="list-style-type: none"> <li>• Hub-7E</li> <li>• Hub-14</li> </ul>	<ul style="list-style-type: none"> <li>• HP J3137A</li> <li>• HP J2415A</li> </ul>	100VG-AnyLAN hubs with 7 and 14 ports respectively. The Hub 14 can be managed.	<ul style="list-style-type: none"> <li>• 5-34</li> <li>• 5-34</li> </ul>
Remote connectivity: <ul style="list-style-type: none"> <li>• Internet Router Module</li> <li>• Internet Router/Remote 2C Bundle</li> </ul>	<ul style="list-style-type: none"> <li>• HP J3138A</li> <li>• HP J3231A</li> </ul>	Use these products if Internet access or remote office connectivity is needed by the network.	<ul style="list-style-type: none"> <li>• 5-40</li> <li>• 5-40</li> </ul>

**Building the Workgroup: Shared 100Mbps.** This is a small 100Mbps workgroup using basic 100Mbps hubs for desktop connections and for connecting printers and other peripherals. The number of users is small enough that distance between devices should not be an issue (a possible concern for 100Base-T); however two to three hubs may need to be interconnected to handle the number of users. The servers are also connected through one of the 100Mbps hub ports.

For this environment, HP offers a choice of technologies, both of which will work well: 100Base-T hubs and 100VG hubs.

**Advantages.** This is a relatively low-cost solution that provides a significant bandwidth increase over standard Ethernet networks.

Both of HP's 100Mbps hub solutions provide shared 100Mbps performance to your users' desktops, both are stackable and easy to manage, and provide the larger bandwidth for the networking needed in these offices:

- **100Base-T**—if your customer has Category 5 cable installed, use the HP AdvanceStack 100Base-T hubs.
- **100VG-AnyLAN**—if the customer has Category 3 cable installed, use the HP AdvanceStack 100VG hubs.

**Design Notes.** To install either of these 100Mbps technologies, the appropriate 100Mbps network interface card (NIC) must be installed in each PC and server, and printer access requires a print server that supports the chosen 100Mbps technology. HP offers NICs and print servers that support either of these technologies.

For the 100Base-T solution, the Hub-8TXE is a Class-II device, so, if additional ports are needed, two hubs can be cascaded together through the RJ-45 ports. The Hub-12TX and Hub-12TXM come with stacking cables that allow the customer to stack up to five of these hubs creating a larger Class-I repeater.

For the 100VG solution, standard Ethernet topology rules apply: your network should not be configured with more than five layers of hubs.

**Network Monitoring and Management.** If this network size stays the same, you probably do not need to use network management software. However, if the network starts to grow, HP AdvanceStack Assistant can provide valuable suggestions on how to improve your network performance. It is also a valuable tool for troubleshooting.

Applications in this office use the network on an infrequent and unpredictable basis, but require high performance from the network. Common applications include:

- CAD/CAM
- Online transaction processing (OLTP)
- Image processing
- Color printing/plotting/scanning
- Web access and/or presence
- Network computers (diskless)
- Frequent file sharing via a file server
- Large database such as Oracle, Sybase
- Three-tiered client/server (SAP R/3)

Traffic characteristics include:

- Server-based processing
- Frequent and consistent network use
- Larger files (>1 MB) being transferred
- Quick response time needed

**Internet and Remote Office Connections.** To provide access to the Internet, the recommended solution is to create an “open” subnet that has an HP Remote 2C/Internet Router Bundle, which provides the connectivity to the Internet. This open subnet is then connected to the office network through a server configured as a firewall router to provide security.

To add remote office connectivity to this network, the recommended solution is to use either the Switch 208T or Switch 224T as the workgroup switches and install the optional HP Internet Router Module into the expansion slot in the switch. Otherwise, the solution is to use the HP Remote 2C and Internet Router Bundle, which includes the Internet Router and the 2C two-slot expansion cabinet, and connect the cabinet to an available 10Base-T port on one of the workgroup switches in the same way as any other network device.

For more information on Internet and remote office access, refer to “Adding Internet Connectivity” on page 4-42 and “Connecting Remote Sites” on page 4-45.

**Upgrading from 10Base-T Networks.** To upgrade an existing 10Base-T network to an all high-speed network, the existing 10Base-T hubs and NICs must be replaced with either 100Base-T or 100VG hubs and NICs. In the case of 100Base-T, any Category 3 twisted-pair cabling will have to be replaced with Category 5 cabling. For a 100VG network, the Category 3 cabling is still supported. If you already have 10/100Mbps NICs installed in the network computers and Category 5 cabling installed, then only the hubs need to be replaced.

**Expanding the Workgroup.** Expansion of this network will likely require the use of a 100Mbps switch to interconnect the hub segments. A switch that has media flexibility, such as the HP Switch 2000, will also allow you to interconnect these high-speed segments with any 10Mbps segments you have. If possible, each new PC, server, or network peripheral should be equipped with 10/100Mbps or 100Mbps LAN adapters that match the technology being used, 100Base-T or 100VG.





## High-Speed Connections: 50–200 Nodes

Use this model to connect a medium-sized, data-intensive workgroup.

This is a small- to medium-size business, using high-performance computers that share multiple 100Mbps network segments. Users in this environment are running data-intensive applications that need to move megabytes of data in short periods of time. The access to the network is infrequent and unpredictable, but demanding. The network must not be the bottleneck.

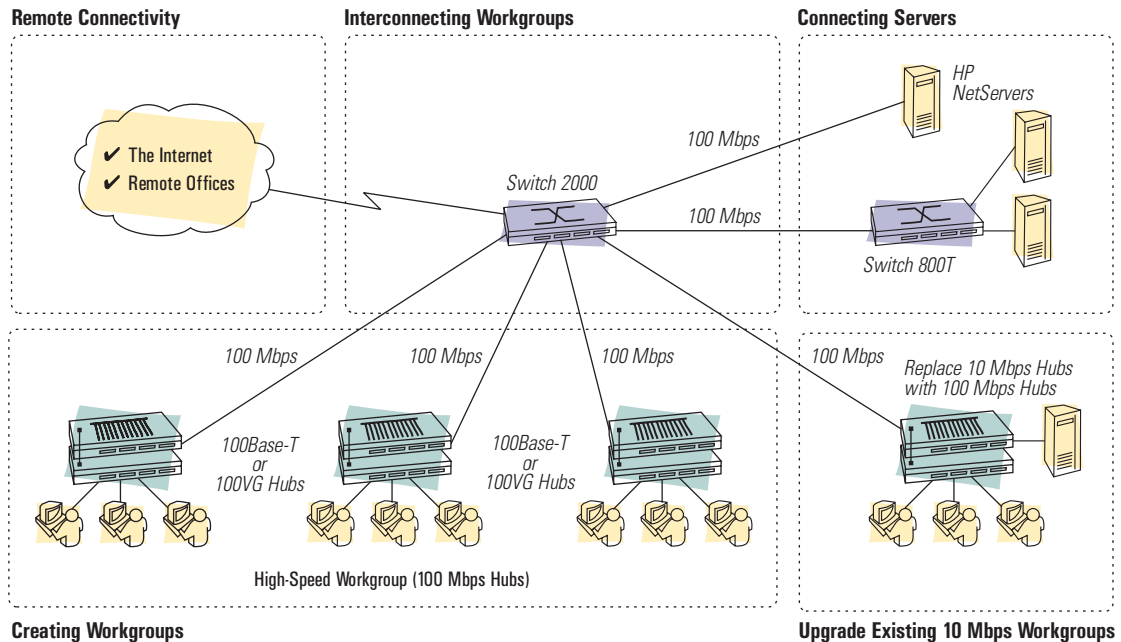

### Shopping List

Product in the Topology	Product Number	Descriptions	Page
<b>100Base-T hubs:</b> <ul style="list-style-type: none"> <li>• Hub-8TXE</li> <li>• Hub-12TX</li> <li>• Hub-12TXM</li> </ul>	<ul style="list-style-type: none"> <li>• HP J3235A</li> <li>• HP J3233A</li> <li>• HP J3234A</li> </ul>	100Base-TX hubs with 8 and 12 RJ-45 ports. The Hub-12TXM includes built-in SNMP management.	<ul style="list-style-type: none"> <li>• 5-30</li> <li>• 5-30</li> <li>• 5-30</li> </ul>
<b>100VG hubs:</b> <ul style="list-style-type: none"> <li>• Hub-7E</li> <li>• Hub-14</li> </ul>	<ul style="list-style-type: none"> <li>• HP J3137A</li> <li>• HP J2415A</li> </ul>	100VG-AnyLAN hubs with 7 and 14 ports respectively. The Hub 14 can be managed.	<ul style="list-style-type: none"> <li>• 5-34</li> <li>• 5-34</li> </ul>
<b>Interconnect switches:</b> <ul style="list-style-type: none"> <li>• Switch 2000</li> <li>• Switch 800T</li> </ul>	<ul style="list-style-type: none"> <li>• HP J3100B</li> <li>• HP J3245A</li> </ul>	The Switch 2000 is a 6-slot modular switch for installing 10Base-T, 10Base-FL, 100Base-T, 100VG, FDDI, and ATM modules. The Switch 800T has 8 transceiver slots for installing HP 100Base-TX or 100Base-FX transceivers.	<ul style="list-style-type: none"> <li>• 5-10</li> <li>• 5-14</li> </ul>
<b>Remote connectivity:</b> <ul style="list-style-type: none"> <li>• Internet Router Module</li> <li>• Internet Router/Remote 2C Bundle</li> </ul>	<ul style="list-style-type: none"> <li>• HP J3138A</li> <li>• HP J3231A</li> </ul>	Use these products if Internet access or remote office connectivity is needed by the network.	<ul style="list-style-type: none"> <li>• 5-40</li> <li>• 5-40</li> </ul>

**Building the Workgroup: Shared and Switched 100Mbps.** This network is essentially multiple versions of the 5–50 node high-speed network model, connected together through twisted-pair or fiber-optic cable connections to a segment switch, for example, the HP Switch 2000. Each workgroup is a single 100Base-T or 100VG segment. Please see the Design Notes below for information on how many hubs can be connected together for 100Base-T and 100VG to form the segment.

For connecting the servers to this network, if there are a small number of servers, they may be connected directly to the segment switch. If there are a larger number of servers or an increased amount of server-to-server traffic, it may be more cost effective to concentrate the servers by connecting them in a 100Base-T environment to a workgroup switch, for example the Switch 800T, and that switch is then connected to the segment switch. Between the servers and workgroup switch, full duplex has been enabled on the switch and the LAN adapter in each server. This gives each server connection a throughput of 200Mbps.

**Advantages.** This is a scalable 100Mbps network—more users can be added easily by just adding more hub ports. The overall network performance is maintained by keeping each workgroup node count relatively small (*a maximum of approximately 50 nodes is recommended*) and connecting the workgroups together through 100Mbps switching. Connecting the servers to this network through the switch also isolates the servers from unwanted workgroup traffic.

Keeping each workgroup relatively small is beneficial for 100Base-T networks both in providing optimal usable bandwidth for each user and for the topology flexibility it provides. In addition, it allows for faster, easier problem isolation and fixing.

#### Design Notes.

- To install either of these 100Mbps technologies, the appropriate 100Mbps network interface card (NIC) must be installed in each PC and server, and printer access requires a print server that supports the chosen 100Mbps technology. HP offers NICs and print servers that support either of these technologies.
- For the 100Base-T solution, the Hub-8TXE is a Class-II device, so, if additional ports are needed, two hubs can be cascaded together through the RJ-45 ports. The Hub-12TX and Hub-12TXM come with stacking cables that allow the customer to stack up to five of these hubs creating a larger Class-I repeater.
- For the 100VG solution, standard Ethernet topology rules apply: up to five levels of hubs can be cascaded together, although a maximum of three levels of cascading is recommended for optimal performance.
- Any switch-to-switch connections in the network should be created by “trunking” multiple 100Mbps connections. If the customer is using 100Base-T devices, each switch-to-switch connection should be configured to run in full-duplex mode providing 200Mbps per connection. The Switch 2000 and the Switch 800T both support this trunking feature.

Applications in this office use the network on an infrequent and unpredictable basis, but require high performance from the network. Common applications include:

- CAD/CAM
- Online transaction processing (OLTP)
- Image processing
- Color printing/plotting/scanning
- Web access and/or presence
- Network computers (diskless)
- Frequent file sharing via a file server
- Large database such as Oracle, Sybase
- Three-tiered client/server (SAP R/3)

Traffic characteristics include:

- Server-based processing
- Frequent and consistent network use
- Larger files (>1 MB) being transferred
- Quick response time needed

- Consider using the Layer 3 Switching and Automatic Broadcast Control features of the Switch 2000 and 800T to control broadcast traffic, and the IGMP feature to optimize use of the network bandwidth for multimedia. These features can be configured through either the console interface for both switches, or through ASA. For more information on these features, see chapter 6, “Switching Technology”.

**Network Monitoring and Management.** Network Management software would provide valuable information for this network. Using the Network Performance Advisor, a feature of HP AdvanceStack Assistant, you can look at traffic flow, top talkers, and get suggestions on how to improve the network.

**Internet and Remote Office Connections.** To provide access to the Internet, the recommended solution is to create an “open” subnet that has an HP Remote 2C/Internet Router Bundle, which provides the connectivity to the Internet. This open subnet is then connected to the office network through a server configured as a firewall router to provide security.

To add remote office connectivity to this network, the recommended solution is to install the HP Remote 2C and Internet Router Bundle in the network. If the network is 100Base-T, connect the Remote 2C 10Base-T port to one of the 10/100Base-T transceiver ports in either the Switch 800T or Ethernet Module installed in the Switch 2000. If the network is 100VG, connect the 100VG port on the Remote 2C directly to one of the ports on a 100VG Module installed in the Switch 2000 or to any 100VG hub in the network.

For more information on Internet and remote office access, refer to “Adding Internet Connectivity” on page 4-42 and “Connecting Remote Sites” on page 4-45.

**Upgrading from 10Base-T Networks.** To upgrade an existing 10Base-T network to an all high-speed network, the existing 10Base-T hubs and NICs must be replaced with either 100Base-T or 100VG hubs and NICs. In the case of 100Base-T, any Category 3 twisted-pair cabling will have to be replaced with Category 5 cabling. For a 100VG network, the Category 3 cabling is still supported. If you already have 10/100Mbps NICs installed in the network computers and Category 5 cabling installed, then only the hubs need to be replaced.

**Expanding the Workgroup.** Expansion of this network can be easily accomplished by adding more 100Mbps hub ports to accommodate adding new users, and connecting these hubs to the 100Mbps switches. If possible, each new PC, server, or network peripheral should be equipped with 10/100Mbps or 100Mbps LAN adapters that match the technology being used, 100Base-T or 100VG.



## High-Speed Connections: 200–1000 Nodes

*Use this model for large, data-intensive networks.*

This is a medium- to large-size network for data-intensive applications. Multiple buildings and floors and connected through 100Mbps links. A network of this size must be split into multiple workgroup segments and certainly has multiple servers. The access to the network is infrequent and unpredictable, but demanding.

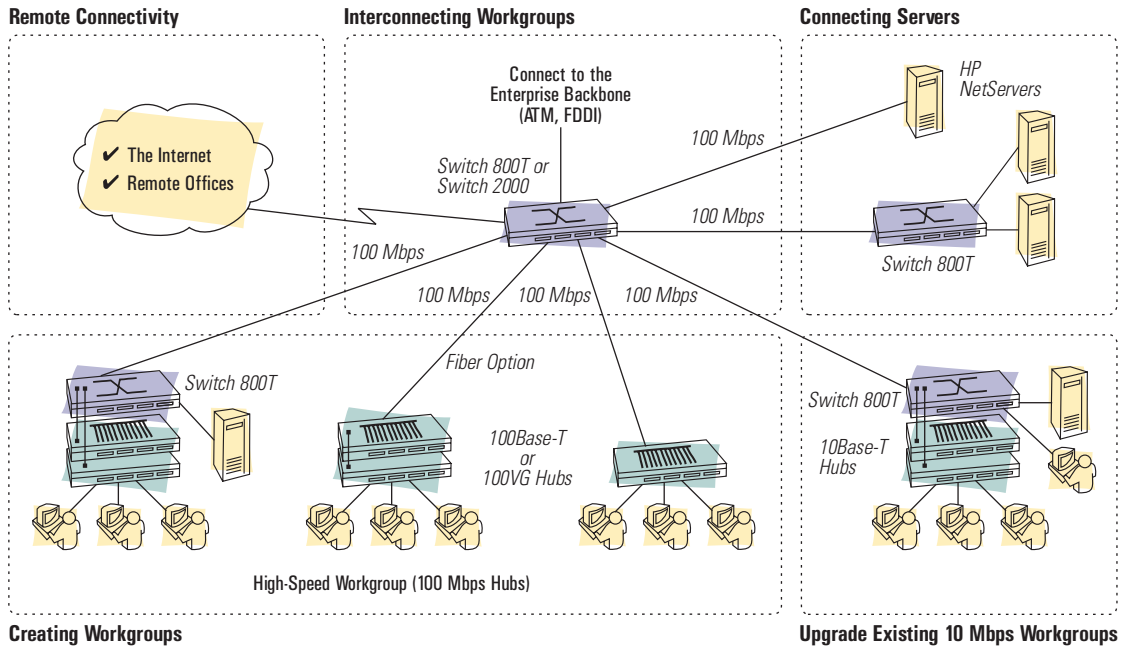

### Shopping List

Product in the Topology	Product Number	Descriptions	Page
100Base-T hubs:			
• Hub-12TX	• HP J3233A	100Base-TX class-I repeaters with 12 RJ-45 ports. The Hub-12TXM includes built-in SNMP management.	• 5-30
• Hub-12TXM	• HP J3234A		• 5-30
• Hub-24TX	• HP J3272A	100Base-TX class-1 repeater with 24 RJ-45 ports.	• 5-30
100VG hubs:			
• Hub-7E	• HP J3137A	These are 100VG-AnyLAN hubs with 7 and 14 ports respectively. The Hub 14 can be managed.	• 5-34
• Hub-14	• HP J2415A		• 5-34
Interconnect switches:			
• Switch 2000	• HP J3100B	The Switch 2000 is a 6-slot modular switch for installing 10Base-T, 10Base-FL, 100Base-T, 100VG, FDDI, and ATM modules. The Switch 800T has 8 transceiver slots for installing HP 100Base-TX or 100Base-FX transceivers.	• 5-10
• Switch 800T	• HP J3245A		• 5-14
Remote connectivity:			
• Internet Router Module	• HP J3138A	Use these products if Internet access or remote office connectivity is needed by the network.	• 5-40
• Internet Router/Remote 2C Bundle	• HP J3231A		• 5-40

**Building the Workgroup: Shared and Switched 100Mbps; Interconnected Switches.** This topology features these characteristics:

- 100Mbps hubs (100Base-T and/or 100VG) form the workgroups.
- 100Mbps workgroup switches consolidate the workgroups on entire floors or buildings.
- 100Mbps interconnect switch interconnects the workgroup switches together.
- A dedicated 100Mbps switch for the servers has been added.

**Advantages.**

- This is a scalable 100Mbps network—more users and servers can be added easily by just adding more hub ports.
- The overall network performance is maintained by keeping each workgroup node count relatively small (***a maximum of approximately 50 nodes is recommended***) and connecting the workgroups together through 100Mbps switching.
- Connecting the servers to this network through the switch isolates the servers from unwanted workgroup traffic.
- Keeping each workgroup relatively small is beneficial for 100Base-T networks both in providing optimal usable bandwidth for each user and for the topology flexibility it provides. In addition, it allows for faster, easier problem isolation and fixing.
- Optional SNMP management enables performance and network monitoring on all ports
- Uses broadcast traffic control and layer 3 switching to enhance scalability and fault isolation

**Design Notes.**

- To install either of these 100Mbps technologies, the appropriate 100Mbps network interface card (NIC) must be installed in each PC and server, and printer access requires a print server that supports the chosen 100Mbps technology. HP offers NICs and print servers that support either of these technologies.
- For the 100Base-T solution, the Hub-12TX and Hub-12TXM come with stacking cables that allow the customer to stack up to five of these hubs creating a larger Class-I repeater.
- For the 100VG solution, standard Ethernet topology rules apply: up to five hubs can be cascaded together, although a maximum of three levels of cascading is recommended for optimal performance.
- Any switch-to-switch connections in the network should be created by “trunking” multiple 100Mbps connections. If the customer is using 100Base-T devices, each switch-to-switch connection should be configured to run in full-duplex mode providing 200Mbps per connection. The Switch 2000 and the Switch 800T both support this trunking feature.
- 100Base-T connections between the servers and switches should also be configured in full-duplex mode to provide 200Mbps bandwidth.

Applications in this office use the network on an infrequent and unpredictable basis, but require high performance from the network. Common applications include:

- CAD/CAM
- Online transaction processing (OLTP)
- Image processing
- Color printing/plotting/scanning
- Web access and/or presence
- Network computers (diskless)
- Frequent file sharing via a file server
- Large database such as Oracle, Sybase
- Three-tiered client/server (SAP R/3)

Traffic characteristics include:

- Server-based processing
- Frequent and consistent network use
- Larger files (>1 MB) being transferred
- Quick response time needed

- Consider using the Layer 3 Switching and Automatic Broadcast Control features of the Switch 2000 and 800T to control broadcast traffic, and the IGMP feature to optimize use of the network bandwidth for multimedia. These features can be configured through either the console interface for both switches, or through ASA. For more information on these features, see chapter 6, “Switching Technology”.

**Network Monitoring and Management.** Network Management software would provide valuable information for this network. Using the Network Performance Advisor in HP AdvanceStack Assistant (ASA), you can look at traffic flow, top talkers, and get suggestions on how to improve the network. ASA is also an excellent troubleshooting tool.

**Internet and Remote Office Connections.** To provide access to the Internet, the recommended solution is to create an “open” subnet that has an HP Remote 2C/Internet Router Bundle, which provides the connectivity to the Internet. This open subnet is then connected to the office network through a server configured as a firewall router to provide security.

To add remote office connectivity to this network, the recommended solution is to install the HP Remote 2C and Internet Router Bundle in the network. If the network is 100Base-T, connect the Remote 2C 10Base-T port to one of the 10/100Base-T transceiver ports in either the Switch 800T or Ethernet Module installed in the Switch 2000. (The switch port must be configured to operate in 10Base-T mode.) If the network is 100VG, connect the 100VG port on the Remote 2C directly to one of the ports on a 100VG Module installed in the Switch 2000 or to any 100VG hub in the network.

In a network of this size, a single remote connection for Internet or remote office communication may not be sufficient to handle all the traffic. The Internet Router Module has two WAN ports which can be used simultaneously to connect the network to the Internet.

For more information on Internet and remote office access, refer to “Adding Internet Connectivity” on page 4-42 and “Connecting Remote Sites” on page 4-45.

**Upgrading from 10Base-T Networks.** To upgrade an existing 10Base-T network to an all high-speed network, the existing 10Base-T hubs and NICs must be replaced with either 100Base-T or 100VG hubs and NICs. In the case of 100Base-T, any Category 3 twisted-pair cabling will have to be replaced with Category 5 cabling. For a 100VG network, the Category 3 cabling is still supported. If you already have 10/100Mbps NICs installed in the network computers and Category 5 cabling installed, then only the hubs need to be replaced.

**Expanding the Workgroup.** Expansion of this network can be easily accomplished by adding more 100Mbps hub ports to accommodate adding new users, and connecting these hubs to the 100Mbps switches. If possible, each new PC, server, or network peripheral should be equipped with 10/100Mbps or 100Mbps LAN adapters that match the technology being used, 100Base-T or 100VG.

The topology shown in this section effectively represents a single building. On a multi-building campus, a network like this can be built in each building. The buildings can then be connected together by connecting each of the interconnect switches to the campus backbone.



## Guaranteed-Bandwidth Connections: 5–50 Nodes

Use this model to connect a 100Mbps server to power 10Mbps workgroups.

This topology shows a power workgroup of 10Mbps desktops connected to a 100Mbps resource (for example, a server). Guaranteed bandwidth is provided to each end node by connecting each one to a desktop switch port. The switch provides a dedicated 10Mbps bandwidth to each port. End nodes in this environment are running network intensive applications and do not wish to be degraded in performance by the actions of others.

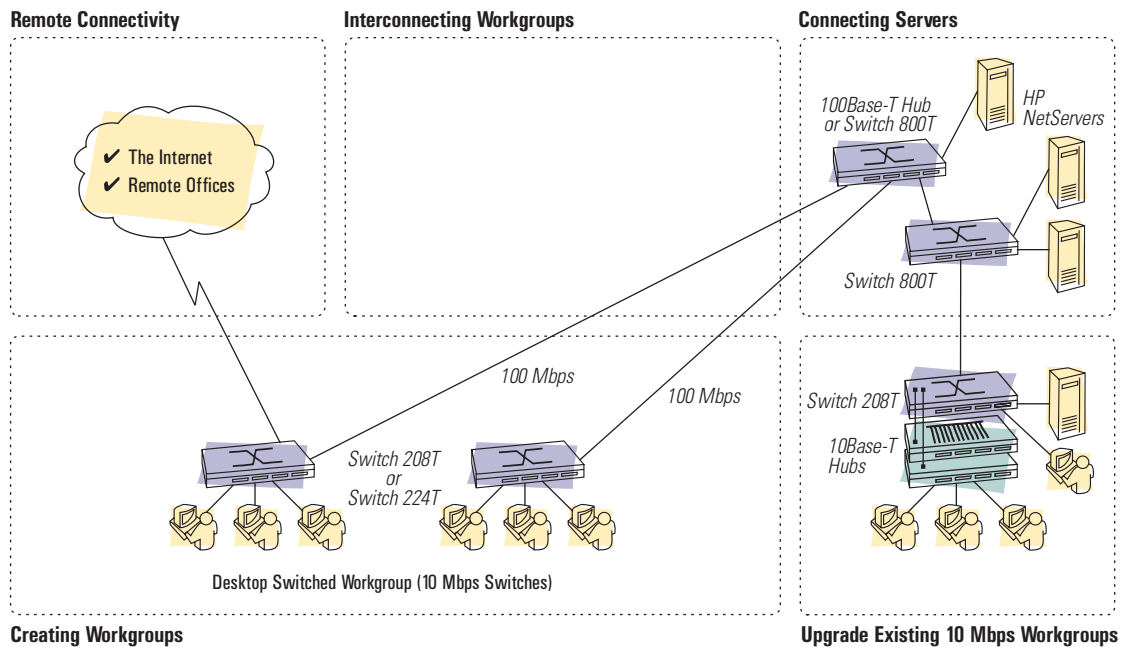

### Shopping List

Product in the Topology	Product Number	Descriptions	Page
Workgroup switches: • Switch 208T • Switch 224T	• HP J3175A • HP J3177A	8- and 24-port 10Base-T switches with two 100Mbps uplinks and expansion slots for adding the Internet Router Module and an SNMP management module.	• 5-18 • 5-18
100Base-T hubs: • Hub-8TXE • Hub-12TX • Hub-12TXM • Hub-24TX	• HP J3235A • HP J3233A • HP J3234A • HP J3272A	100Base-TX hubs with 8 and 12 RJ-45 ports. The Hub-12TXM includes built-in SNMP management.  100Base-TX hub with 24 RJ-45 ports.	• 5-30 • 5-30 • 5-30 • 5-30
Remote connectivity: • Internet Router Module • Internet Router/Remote 2C bundle	• HP J3138A • HP J3231A	Use these products if Internet access or remote office connectivity is needed by your network.	• 5-40 • 5-40

**Building the Workgroup: Switched 10Base-T.** Each workgroup has been set up with a desktop switch to give each user their own 10Mbps dedicated line. Each end user connection is through a four-pair Category 5 or Category 3 cable with a 100 meters maximum between the user and the desktop switches.

The connection from the desktop switch to a server is through a 100Base-T port on the switch, which can be made directly to a 100Base-T NIC in the server.

If multiple workgroups require access to the same server (as shown in the topology illustration), install a 100Base-T hub or switch between the desktop switches and the server. If multiple servers are also used (a server farm), a 100Base-T switch should be used to connect the servers together and to the desktop switches; then, each server connection will have a dedicated 100Mbps bandwidth.

For any 100Base-T connections in the network, Category 5 cable must be used, and the connections are again a maximum of 100 meters.

**Advantages.** Compared with a standard 10Base-T shared network formed by hubs, this workgroup performance has been significantly upgraded by simply replacing 10Base-T hubs with 10Base-T switches for end-node connections. No modifications are needed to any of the PCs, or workstations, although 100Mbps NICs should be installed in any servers.

This topology has several advantages:

- guaranteed network bandwidth for each user
- preservation of existing end-user hardware
- a significant improvement in network performance by simply replacing workgroup hubs with switches
- increased speed to servers

**Network Monitoring and Management.** If this network size stays under 50 nodes, network management software may not be needed. However, if the network starts to grow, HP AdvanceStack Assistant can provide valuable suggestions on how to improve your network including where to place servers. Because HP AdvanceStack Assistant is included with all managed HP hubs and switches, it should be readily available at the customer site. You can install the software for the customer and explain when it should be used and how to select the Network Performance Advisor.

Applications in this office must be easily accessed all the time for the users on this network. Common applications requiring guaranteed bandwidth include:

- Video
- Time-sensitive applications
- White boarding
- Remote training
- Internet phone

Traffic characteristics include:

- Guaranteed bandwidth needed
- Delay/latency sensitive
- Constant, streaming data

**Internet and Remote Office Connections.** To provide access to the Internet, the recommended solution is to create an “open” subnet that has an HP Remote 2C/Internet Router Bundle, which provides the connectivity to the Internet. This open subnet is then connected to the office network through a server configured as a firewall router to provide security.

To add remote office connectivity to this network, the recommended solution is to install an HP Internet Router Module into the Switch 208T or Switch 224T desktop switch, or install an HP Internet Router/Remote 2C bundle in the network. If you use the Remote 2C bundle, you can connect its 10Base-T port to one of the 10/100Base-T transceiver ports in the Switch 800T. (The switch port must be configured to operate in 10Base-T mode.)

For more information on Internet and remote office access, refer to “Adding Internet Connectivity” on page 4-42 and “Connecting Remote Sites” on page 4-45.

**Upgrading Existing 10Base-T Workgroups.** You can preserve the customer’s investment in 10Base-T hubs and still improve bandwidth for each user by adding a switch to the workgroup and connecting each hub to a switch port. Each hub then gets a dedicated 10Mbps bandwidth to be shared by the end nodes connected to that hub. Whereas in the all-hub network, all the end nodes connected to all the hubs were sharing 10Mbps. In this case shown in the illustration, notice that there are two hubs, so there are two connections between the one switch and two hubs.

Connecting servers to the switch ports also provides dedicated bandwidth to the servers and maintains access to the servers for all the users.

To fully upgrade the network so that each user gets a dedicated 10Mbps, the hubs must be replaced with desktop switches.

**Expanding the Workgroup.** As more users are added to this network, more switch ports will need to be added to maintain the dedicated bandwidth. Since each switch forms a separate segment, to reestablish connection between the users, an interconnect switch should be added, as shown in the next topology, “Guaranteed-Bandwidth Connections: 50–200 Nodes”.



## Guaranteed-Bandwidth Connections: 50–200 Nodes

*Use this network to increase performance of your small-sized to medium-sized 10Mbps networks.*

This topology is for a small-to medium-size business with multiple power workgroups connected to a 100Mbps resource (for example, a server). Guaranteed bandwidth is provided to each end node by connecting each one to a desktop switch port. The switch provides a dedicated 10Mbps bandwidth to each port. End nodes in this environment are running network intensive applications and do not wish to be degraded in performance by the actions of others.

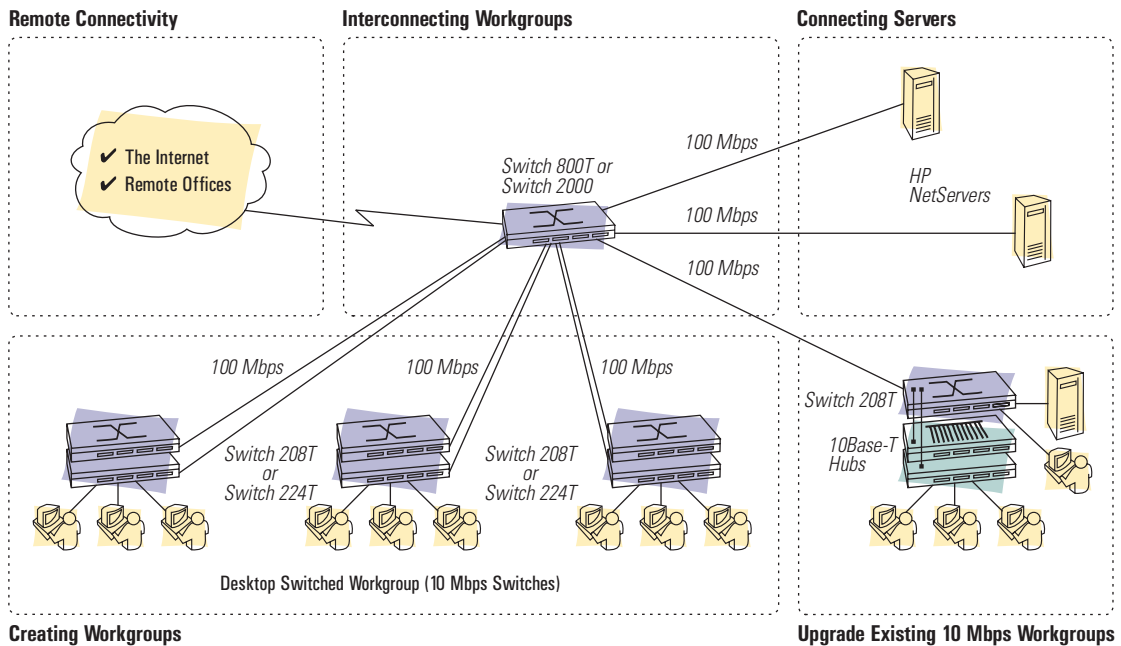

### Shopping List

Product in the Topology	Product Number	Descriptions	Page
<b>Interconnect switches:</b> <ul style="list-style-type: none"> <li>Switch 2000</li> <li>Switch 800T</li> </ul>	<ul style="list-style-type: none"> <li>HP J3100B</li> <li>HP J3245A</li> </ul>	The Switch 2000 is a 6-slot modular switch for installing 10Base-T, 10Base-FL, 100Base-T, 100VG, FDDI, and ATM modules. The Switch 800T has 8 transceiver slots for installing HP 100Base-TX or 100Base-FX transceivers.	<ul style="list-style-type: none"> <li>5-10</li> <li>5-14</li> </ul>
<b>Workgroup switches:</b> <ul style="list-style-type: none"> <li>Switch 208T</li> <li>Switch 224T</li> </ul>	<ul style="list-style-type: none"> <li>HP J3175A</li> <li>HP J3177A</li> </ul>	8- and 24-port 10Base-T switches with two 100Mbps uplinks and expansion slots for adding the Internet Router Module and an SNMP management module.	<ul style="list-style-type: none"> <li>5-18</li> <li>5-18</li> </ul>
<b>100Base-T hubs:</b> <ul style="list-style-type: none"> <li>Hub-8TXE</li> <li>Hub-12TX</li> <li>Hub-12TXM</li> <li>Hub-24TX</li> </ul>	<ul style="list-style-type: none"> <li>HP J3235A</li> <li>HP J3233A</li> <li>HP J3234A</li> <li>HP J3272A</li> </ul>	100Base-TX hubs with 8 and 12 RJ-45 ports. The Hub-12TXM includes built-in SNMP management.  100Base-TX hub with 24 RJ-45 ports.	<ul style="list-style-type: none"> <li>5-30</li> <li>5-30</li> <li>5-30</li> </ul>
<b>Remote connectivity:</b> <ul style="list-style-type: none"> <li>Internet Router Module</li> <li>Internet Router/Remote 2C bundle</li> </ul>	<ul style="list-style-type: none"> <li>HP J3138A</li> <li>HP J3231A</li> </ul>	Use these products if Internet access or remote office connectivity is needed by your network.	<ul style="list-style-type: none"> <li>5-40</li> <li>5-40</li> </ul>

### Building the Workgroup: Switched 10Base-T and 100Base-T.

Each workgroup has been set up with a desktop switch to give each user their own 10Mbps dedicated line. Each end-user connection is through a four-pair Category 5 or Category 3 cable with a 100 meters maximum between the user and the desktop switches.

The workgroup switches are then connected together through 100Base-T uplinks to a 100Base-T interconnect switch, for example the HP Switch 800T, or an HP Switch 2000 with 100Base-T Modules installed.

The servers have 100Base-T NICs in them and are also connected to the interconnect switch.

**Advantages.** This topology is an expansion of the guaranteed-bandwidth topology for 5–50 nodes, so it offers all the same advantages:

- guaranteed network bandwidth for each user
- preservation of existing end-user hardware
- a significant improvement in network performance by simply replacing workgroup hubs with switches
- high-speed access to servers

The addition of the interconnect switch to connect all the workgroup switches together also increases the flexibility of the network providing these additional advantages:

- A scalable network—more users and servers can be added easily by just adding more switch ports.
- Maintenance of overall network performance by keeping each workgroup node count relatively small (***a maximum of approximately 50 nodes is recommended***) and connecting the workgroups together through 100Mbps switching.
- Keeping each workgroup relatively small is beneficial for 100Base-T networks both in providing optimal usable bandwidth for each user and for the topology flexibility it provides. In addition, it allows for faster, easier problem isolation and fixing.
- Isolation of servers from unwanted workgroup traffic by connecting them through the switch.
- Optional SNMP management to enable performance and network monitoring on all ports.
- Availability of broadcast traffic control and layer 3 switching on the interconnect switch to enhance scalability and fault isolation.

Applications in this office must be easily accessed all the time for the users on this network. Common applications requiring guaranteed bandwidth include:

- Video
- Time-sensitive applications
- White boarding
- Remote training
- Internet phone

Traffic characteristics include:

- Guaranteed bandwidth needed
- Delay/latency sensitive
- Constant, streaming data

### Design Notes.

- For all 100Base-T connections over UTP cable in the network, Category 5 cable must be used. If possible, these connections should be configured to run at full duplex. Install an HP Switch 208/224 Management Module in the desktop switches to allow the 100Base-T uplinks from them to the interconnect switch to be configured to run in full duplex.
- For greater distances, these switch-to-switch connections could be through fiber-optic cables. The desktop switches, Switch 208T and Switch 224T, and the interconnect switches, Switch 800T and Switch 2000, all support installation of the HP 100Base-FX fiber-optic transceiver.
- If the interconnect switch in the middle of the network is a Switch 2000, this is a powerful switch that could be used to also connect this workgroup to a campus backbone. If your backbone is ATM or FDDI, you can add the HP ATM Uplink Module or the HP FDDI Module to the Switch 2000 at any time, with available slot space.
- If server access is still not fast enough at 200Mbps, consider adding a second LAN adapter to each server and another connection to the segment switch.

**Network Monitoring and Management.** Network management software would provide valuable information for this network. HP AdvanceStack Assistant will examine your network and provide improvement suggestions. Because HP AdvanceStack Assistant is included with all managed HP hubs and switches, it should be readily available at the customer site. You can install the software for the customer and explain when it should be used and how to select the Network Performance Advisor.

**Internet and Remote Office Connections.** To provide access to the Internet from this workgroup, the solution is to create an “open” subnet into which the customer can install an HP Remote 2C/Internet Router bundle in the part of the network that contains any web servers and proxy servers. Two Internet Router Modules providing up to four WAN ports can be installed in the Remote 2C to provide Internet connection. This open subnet is then connected to the office network through a server configured as a firewall router to provide security.

To provide remote office connectivity, the customer can install an HP Internet Router Module into the expansion slot in any Switch 208T or Switch 224T desktop switch in the network. Or, an HP Remote 2C/Internet Router bundle can be installed in the network and connected to the interconnect switch or other convenient location in the network.

For more information on Internet and remote office access, refer to “Adding Internet Connectivity” on page 4-42 and “Connecting Remote Sites” on page 4-45.

**Upgrading Existing 10Base-T Workgroups.** You can preserve the customer's investment in 10Base-T hubs and still improve bandwidth for each user by just adding a switch to the hub workgroups and connecting each hub to a switch port. Each hub then gets a dedicated 10Mbps bandwidth to be shared by the end nodes connected to that hub. Whereas in the all-hub network, all the end nodes connected to all the hubs were sharing 10Mbps.

Connecting servers to the switch ports also provides dedicated bandwidth to the servers and maintains access to the servers for all the users.

To fully upgrade the network so that each user gets a dedicated 10Mbps, the hubs must be replaced with desktop switches.

**Expanding the Network.** In comparison to a network with a switch for each group, this network adds a backbone switch (shown in center of illustration.) Now each group gets its own 100Mbps link into the backbone of your buildings. Now each group will have faster communication to other workgroups in another building or another floor.



## Guaranteed-Bandwidth Connections: 200–1000 Nodes

*This will increase the performance of your medium-sized to large-sized 10Mbps network.*

This topology is for a medium- to large-size business with multiple power workgroups connected to a 100Mbps resource (for example, a server). Guaranteed bandwidth is provided to each end node by connecting each one to a desktop switch port. The switch provides a dedicated 10Mbps bandwidth to each port. The workgroups are connected together and to the servers through an interconnect switch. End nodes in this environment are running network intensive applications and do not wish to be degraded in performance by the actions of others.

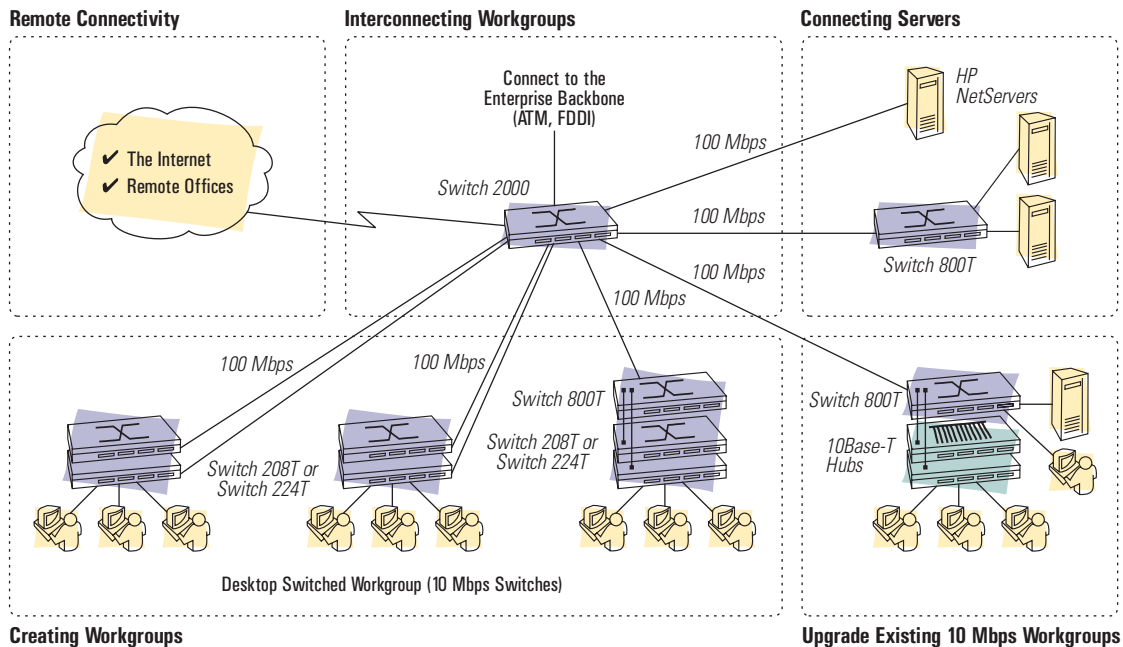

Creating Workgroups

Upgrade Existing 10 Mbps Workgroups

### Shopping List

Product in the Topology	Product Number	Descriptions	Page
<b>Interconnect switches:</b> <ul style="list-style-type: none"> <li>• Switch 2000</li> <li>• Switch 800T</li> </ul>	<ul style="list-style-type: none"> <li>• HP J3100B</li> <li>• HP J3245A</li> </ul>	The Switch 2000 is a 6-slot modular switch for installing 10Base-T, 10Base-FL, 100Base-T, 100VG, FDDI, and ATM modules. The Switch 800T has 8 transceiver slots for installing HP 100Base-TX or 100Base-FX transceivers.	<ul style="list-style-type: none"> <li>• 5-10</li> <li>• 5-14</li> </ul>
<b>Workgroup switches:</b> <ul style="list-style-type: none"> <li>• Switch 208T</li> <li>• Switch 224T</li> </ul>	<ul style="list-style-type: none"> <li>• HP J3175A</li> <li>• HP J3177A</li> </ul>	8- and 24-port 10Base-T switches with two 100Mbps uplinks and expansion slots for adding the Internet Router Module and an SNMP management module.	<ul style="list-style-type: none"> <li>• 5-18</li> <li>• 5-18</li> </ul>
<b>100Base-T hubs:</b> <ul style="list-style-type: none"> <li>• Hub-8TXE</li> <li>• Hub-12TX</li> <li>• Hub-12TXM</li> <li>• Hub-24TX</li> </ul>	<ul style="list-style-type: none"> <li>• HP J3235A</li> <li>• HP J3233A</li> <li>• HP J3234A</li> <li>• HP J3272A</li> </ul>	100Base-TX hubs with 8 and 12 RJ-45 ports. The Hub-12TXM includes built-in SNMP management.	<ul style="list-style-type: none"> <li>• 5-30</li> <li>• 5-30</li> <li>• 5-30</li> <li>• 5-30</li> </ul>
<b>Remote connectivity:</b> <ul style="list-style-type: none"> <li>• Internet Router Module</li> <li>• Internet Router/Remote 2C bundle</li> </ul>	<ul style="list-style-type: none"> <li>• HP J3138A</li> <li>• HP J3231A</li> </ul>	Use these products if Internet access or remote office connectivity is needed by your network.	<ul style="list-style-type: none"> <li>• 5-40</li> <li>• 5-40</li> </ul>

### Building the Workgroup: Switched 10Base-T and 100Base-T.

Each workgroup has been set up with a desktop switch to give each user their own 10Mbps dedicated line. Each-end user connection is through a four-pair Category 5 or Category 3 cable with a 100 meters maximum between the user and the desktop switches.

The workgroup switches are then connected together through 100Base-T uplinks to a 100Base-T interconnect switch, for example the HP Switch 800T, or an HP Switch 2000 with 100Base-T Modules installed.

The servers have 100Base-T NICs in them and are connected either directly to the interconnect switch or to a 100Base-T switch in the server area, forming a server farm. This server farm switch is then connected to the interconnect switch, preferably through a trunk of multiple 100Base-T connections to remove any bottlenecks from users to servers and server-to-server connections.

If the interconnect switch is a Switch 2000, it can be connected to an enterprise-wide backbone with high-speed modules such as ATM, or FDDI.

**Advantages.** This topology is an expansion of the guaranteed-bandwidth topology for 50–200 nodes, so it offers all the same advantages:

- guaranteed network bandwidth for each user
- preservation of existing end-user hardware
- a significant improvement in network performance by simply replacing workgroup hubs with switches
- high-speed access to servers

The interconnect switch also increases the flexibility of the network providing these additional advantages:

- a scalable network—more users and servers can be added easily by just adding more switch ports
- maintenance of overall network performance by keeping each workgroup node count relatively small (***a maximum of approximately 50 nodes is recommended***) and connecting the workgroups together through 100Mbps switching
- isolation of servers from unwanted workgroup traffic by connecting them through the switch
- optional SNMP management to enable performance and network monitoring on all ports
- availability of broadcast traffic control and layer 3 switching on the interconnect switch to enhance scalability and fault isolation

By using the Switch 2000, you can enable three features that are built into this product:

- Multimedia support
- Layer 3 Switching
- Automatic Broadcast Control

Applications in this office must be easily accessed all the time for the users on this network. Common applications requiring guaranteed bandwidth include:

- Video
- Time-sensitive applications
- White boarding
- Remote training
- Internet phone

Traffic characteristics include:

- Guaranteed bandwidth needed
- Delay/latency sensitive
- Constant, streaming data

For multimedia applications, the Switch 2000 dynamically allocates network bandwidth to support video servers and multimedia applications to produce high quality of service.

#### Design Notes.

- For all 100Base-T connections over UTP cable in the network, Category 5 cable must be used. If possible, these connections should be configured to run at full duplex. Install an HP Switch 208/224 Management Module in the desktop switches to allow the 100Base-T uplinks from them to the interconnect switch to be configured to run in full duplex.
- For greater distances, these switch-to-switch connections could be through fiber-optic cables. The desktop switches, Switch 208T and Switch 224T, and the interconnect switches, Switch 800T and Switch 2000, all support installation of the HP 100Base-FX fiber-optic transceiver.
- If the interconnect switch in the middle of the network is a Switch 2000, this is a powerful switch that could be used to also connect this workgroup to a campus backbone. If your backbone is ATM or FDDI, you can add the HP ATM Uplink Module or the HP FDDI Module to the Switch 2000 at any time, with available slot space.
- If server access is still not fast enough at 200Mbps, consider adding a second LAN adapter to each server and another connection to the segment switch.

**Network Monitoring and Management.** Use HP AdvanceStack Assistant software to provide valuable information for this network. Using the Network Performance Advisor, you can look at traffic flow, top talkers, and get suggestions on how to improve the network. In HP AdvanceStack Assistant, you can turn on Layer 3 Switching and multimedia support with one click on each screen. For each server connection, use HP AdvanceStack Assistant to set the server LAN adapter (NICs) and the connected device to full duplex for maximum throughput. For each segmentable hub (such as the HP Switching Hub), specify the segments in HP AdvanceStack Assistant so that each user gets as much bandwidth as possible.

**Internet and Remote Office Connections.** To provide access to the Internet from this workgroup, the solution is to create an “open” subnet into which the customer can install an HP Remote 2C/Internet Router bundle in the part of the network that contains any web servers and proxy servers. Two Internet Router Modules providing up to four WAN ports can be installed in the Remote 2C to provide Internet connection. This open subnet is then connected to the office network through a server configured as a firewall router to provide security.

To provide remote office connectivity, the customer can install an HP Internet Router Module into the expansion slot in any Switch 208T or Switch 224T desktop switch in the network. Or, an HP Remote 2C/Internet Router bundle can be installed in the network and connected to the interconnect switch or other convenient location in the network.

In a network of this size, a single remote connection for Internet or remote office communication may not be sufficient to handle all the traffic. The Internet Router Module has two WAN ports which can be used simultaneously to connect the network to the Internet.

For more information on Internet and remote office access, refer to “Adding Internet Connectivity” on page 4-42 and “Connecting Remote Sites” on page 4-45.

**Upgrading Existing 10Base-T Workgroups.** Existing 10Mbps shared workgroups can be upgraded by installing a 10Mbps top-of-stack workgroup switch and connecting each hub to a separate port on that switch. If the existing hubs can be segmented, enable segmentation to increase bandwidth for those users. Be sure to move the existing servers to the 100Mbps port on the workgroup switch on each hub stack.

When selecting the top-of-stack switch, be sure to select one with media flexibility so that you can change to fiber-optic cable to the server if needed. For example, the pictured Switch 208T has a fixed twisted-pair port and a slot that will accept a twisted-pair or fiber-optic transceiver for connections to the server.

If possible, each new PC should be equipped with a plug-and-play PCI 10/100T or 100T LAN adapters (NICs). The price of 10/100T NIC is economical with the constant demand for this popular technology combination. If server access is still not fast enough at 200Mbps, consider adding a second LAN adapter to each server and another connection to the segment switch.

**Expanding the Workgroup.** In addition to a interconnect switch, a switch has been added to the Creating New Workgroups area of the illustration. Notice that the 8-port 100T workgroup switch (HP Switch 208T) is added to each stack. Each set of users connected to the stack will get 100Mbps access to the Switch 2000 in the center which will improve speed to the printers and original workgroup on the right side of the illustration.

## Adding Internet Connectivity

The Internet has received attention recently for its power to connect employees to libraries of information. Your customers may want to provide Internet access for their users, and they may also want to provide a company presence on the Worldwide Web. The services available can include:

- email gateway to the Internet from local and remote offices
- access to the Internet
- ability to establish a presence on the Internet for commerce, customer information, support services, and more

For these customers, you can provide Web and Internet connections without having to redesign their whole network. Instead, you just add one or two devices to the network.

The number of devices depends primarily on whether the customer wants to host the servers connecting to the Internet or wants the servers to be located at an Internet Service Provider (ISP). The servers contain the web server software and the web pages for the customer's company. An ISP can be local to the area such as a local computer store or local phone company, or it can be one of the existing online services or global telecommunications companies.

When selecting whether your customer wants to host the servers, be sure that they understand the advantages and disadvantages of both situations. Considerations to be taken into account include:

- maintenance of the servers, including keeping the servers and network operational 24 hours per day, 7 days per week, for optimal web access
- control over the equipment purchased and how often it is upgraded
- having staff to design, maintain, and upgrade the web pages

In general, small companies tend to locate the servers at an ISP and large companies tend to keep the equipment on site. This is because large companies tend to have a networking staff that can operate, maintain, and update the equipment and the Web pages.

The topology in this section shows a complete and secure Internet solution for a medium-sized business with an existing intranet. The entire business is provided controlled Internet access and has servers at the customer's site.

### Remote Connectivity

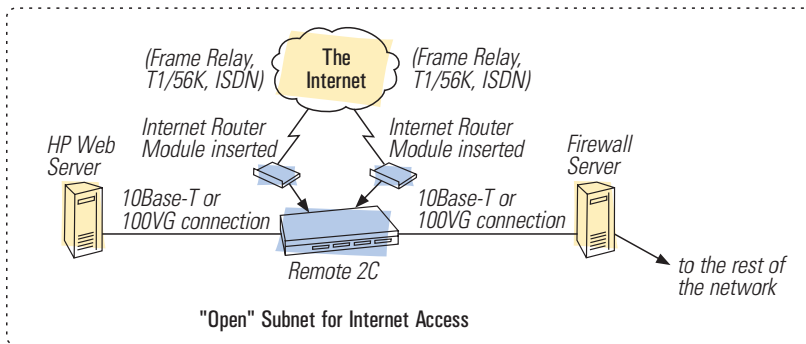

## Shopping List

Product in the Topology	Product Number	Descriptions	Page
Remote connectivity:			
• Internet Router/Remote 2C bundle with Internet Router Module	• HP J3231A	A two-slot chassis with one factory-installed Internet Router Module; also has two RJ-45 ports for connection to local network. Each Internet Router Module has two WAN ports.	• 5-40
• additional Internet Router Module	• HP J3138A		• 5-40

**Building the Connection.** In each of the LAN network topologies described earlier in this chapter, a line is used to indicate the connection between the customer's network and the Internet. The topology shown here provides the details of that connection. To provide a secured connection to the Internet:

- Create a separate **"open" subnet** that has the following equipment on it:
  - Web servers—for storing Web pages for commerce and any other customer services
  - HP J3231A Remote 2C/Internet Router Bundle
- Connect this open subnet to the rest of the customer's network through a **firewall server** that is configured to provide firewall and routing functions. The server configured as a router serves as the security firewall between the Internet and the customer's network, and can also perform Internet proxy functions to prevent the network addresses of the customer's computers from being revealed on the Internet.
- Internet access is provided by connecting the HP J3231A Remote 2C/Internet Router Bundle to the open subnet. Two Internet Router Modules providing up to four WAN ports can be installed in the Remote 2C to provide the Internet connection (one module comes already installed in the bundle product).

**Advantages.** The advantages of this topology are:

- low-cost, flexible, expandable, full router solution
- provides Internet and Worldwide Web access for customer's employees, the ability to establish an Internet presence for the customer's own web site, and for sending and receiving email to the Internet
- configurable to provide a secure Internet connection

**Design Notes.**

- Be sure to store the HP Internet Router Module and its chassis in a locked closet or locked computer room.
- The router configuration needs to be copied to a disk for a quick restore to get the office back online as quickly as possible. If the customer doesn't have time to do it, make the time so that they will be thankful that they can get back online the fastest. In general, routers take more configuration time than a hub or switch.

**Network Monitoring and Management.** You have two choices when configuring and troubleshooting your HP Internet Router Module. The Internet Router Module has a console interface that you can access from the office or from a remote site. You can also use CiscoVision network management software for a graphical view of the device. Please contact Cisco systems for more information on CiscoVision.

**Upgrading the Internet Connections.** If the customer remarks that employees are complaining of slow web page downloads, or their customers are complaining of slow access to the customer's servers, for example, the problem may be from a number of sources including:

- the web sites being accessed have performance problems
- the customer's own LAN may be having performance problems
- the WAN connection to the Internet is being overloaded

If you determine that the problem is this last one, there are some possible remedies:

- increase the speed of the WAN link
- add a second WAN link

Each HP Internet Router Module has two high-speed synchronous WAN ports (DB-60) so it would be relatively easy to add a second Internet connection. Depending on the customer's situation and needs though, it may be cheaper to just upgrade the speed of the existing connection.

# Connecting Remote Sites

Many companies have geographically separated branch offices that need to connect to the central site and to each other. For example, banks, real estate offices, supermarkets, etc. Connecting these sites together allows for these sorts of functions:

- employees at both sites can access the same files and information
- the network management at the central site can do remote installation, configuration, and management of the remote office network
- employees at the remote sites can have access to more powerful network services at the central site, such as access to the Internet

The topology in this section shows inexpensive and flexible ways to connect these remote sites to the central office.

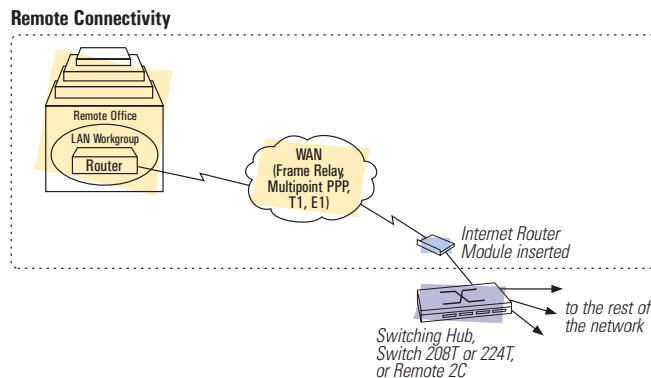

## Shopping List

Product in the Topology	Product Number	Descriptions	Page
For networks that already have an HP Switching Hub or HP Switch 208T or 224T			
• Internet Router Module	• HP J3138A	A router module for installation into the expansion slot of a Switching Hub, or Switch 208T or 224T. Each Internet Router Module has two WAN ports.	• 5-40
For networks that need a chassis to install the Internet Router Module:			
• Internet Router/Remote 2C bundle	• HP J3231A	A two-slot chassis with one factory-installed Internet Router Module; also has two RJ-45 ports for connection to local network. Each Internet Router Module has two WAN ports.	• 5-40



**Building the Connection.** In each of the LAN network topologies described earlier in this chapter, a line is used to indicate the connection between the customer’s central office network and a remote site. The topology shown here provides the details of that connection. The topology shows a portion of the central office and its connection to the remote office. *This same equipment could be used at the remote office end of the connection.*

Install an HP Internet Router Module into the expansion slot of one of the Switching Hubs (Hub-12R, Hub-24R, or Hub-24T), Switch 208T, or Switch 224T units in the network (see Design Note below). Then connect one or more of the module’s ports to the telecommunications equipment that provides the remote link.

**Advantages.** The advantages of the HP Internet Router Module for site-to-site connections are:

- offers an economical remote office solution that combines Cisco’s “best-in-class” technology with HP’s modular workgroup hardware and acclaimed warranty and support
- is seamlessly compatible with Cisco central-site routing solutions
- offers resilient backup WAN links to maintain 100 percent uptime

**Design Notes.**

- Instead of installing the HP Internet Router Module in the expansion slot of a hub or switch, it can be installed in the standalone HP Remote 2C chassis which has two LAN ports for connections to the site network, and two slots for installing Internet Router Modules.
- Be sure to store the HP Internet Router Module and its chassis in a locked closet or locked computer room.
- The router configuration needs to be copied to a disk for a quick restore to get the office back online as quickly as possible. If the customer doesn’t have time to do it, make the time so that they will be thankful that they can get back online the fastest. In general, routers take more configuration time than a hub or switch.

**Network Monitoring and Management.** You have two choices when configuring and troubleshooting your HP Internet Router Module. The Internet Router Module has a console interface that you can access from the office or from a remote site. You can also use CiscoVision network management software for a graphical view of the device. Please contact Cisco systems for more information on CiscoVision.





# Chapter 5: HP Networking Products

---

<b>Network Management</b> .....	5-2
HP AdvanceStack Assistant .....	5-2
Traffic Monitor .....	5-3
Network Performance Advisor .....	5-4
<b>Switches: Product Summary</b> .....	5-6
HP AdvanceStack Switch 2000 .....	5-10
HP AdvanceStack Switch 800T .....	5-14
HP AdvanceStack Switch 208T/224T .....	5-18
<b>Hubs: Product Summary</b> .....	5-22
HP 10Base-T Value Line Hubs .....	5-26
HP AdvanceStack 100Base-T Hubs .....	5-30
HP AdvanceStack 100VG Hubs .....	5-34
HP AdvanceStack Switching Hubs .....	5-36
<b>HP AdvanceStack Internet Router</b> .....	5-40
<b>HP 10/100VG LAN Adapter Cards (NICs)</b> .....	5-42
<b>Accessories Index</b> .....	5-44



# Network Management

HP's management applications are designed to address today's key network management challenges: network uptime, cost, performance, reliability, and growth. These applications increase network control by delivering management information on the entire network.

## HP AdvanceStack Assistant

HP AdvanceStack Assistant is an SNMP-based network management solution that provides all the tools you need for traffic monitoring, network optimization, configuration, and security. It fully integrates with industry-leading HP OpenView for management of multivendor environments and supports RMON, EASE, IP, IPX, and MIB I and II. This comprehensive and easy-to-use software is included with all HP managed hubs and switches at no extra cost.

### Typical Uses:

- Windows 95 and NT networks with up to 1,500 nodes
- for migrating to and managing switched networks

HP AdvanceStack Assistant is designed to:

- automatically discover managed HP devices on your network and make them easily accessible through a topology map
- continuously monitor network traffic in real time; you can pinpoint the "Top 5 Talkers" on each segment that generate the most traffic during any given minute
- analyze historical traffic data and provide recommendations for optimizing the network
- let you conduct most configuration tasks at your PC, rather than in the wiring closet
- make navigation through the network easy through user-definable "friendly names" for nodes and devices

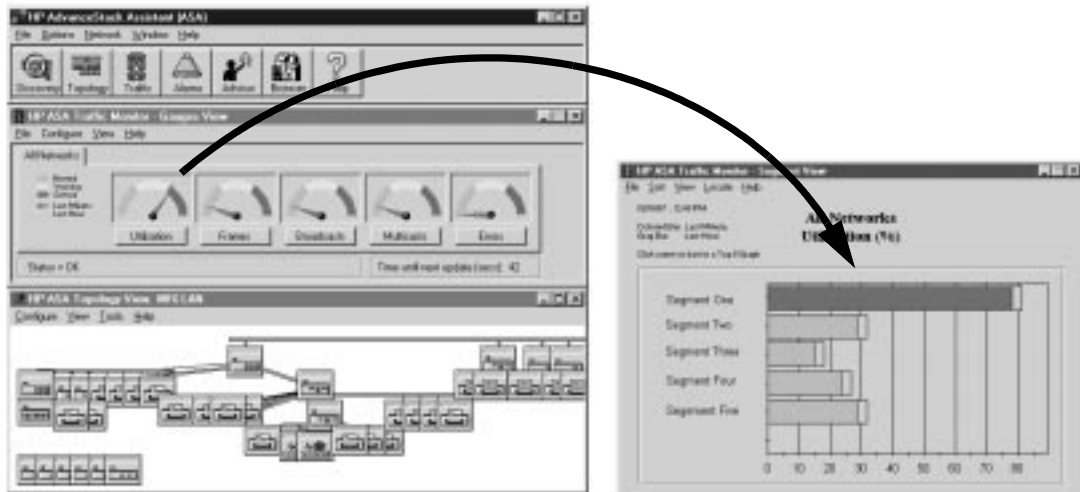

## Traffic Monitor

The Traffic Monitor component of HP AdvanceStack Assistant lets you examine network traffic and proactively identify problem areas based on statistics gathered from sampling devices built into HP devices located across the network. Traffic Monitor continually collects statistics on network traffic and graphically presents a minute-by-minute view of five important areas:

- utilization (% of bandwidth)
- frames (total per second)
- broadcasts (frames per second)
- multicasts (frames per second)
- errors (% of packets received)

These statistics are the basis of three graphical windows that show more detail:

- The **Traffic Monitor Gauges View** shows the levels of activity on the network as a whole or on any segment you select. You can click the mouse button on a gauge to display the Segment View.
- The **Segment View** displays a set of bar charts, one for each network segment, for the selected statistic. Click on the problem segment to go to the next level of detail, the Top 5 View.
- The **Top 5 View** shows the five biggest contributors to the traffic on the segment, or the top five “talkers”. Each talker is identified by source, destination, connection, and the protocol being used.

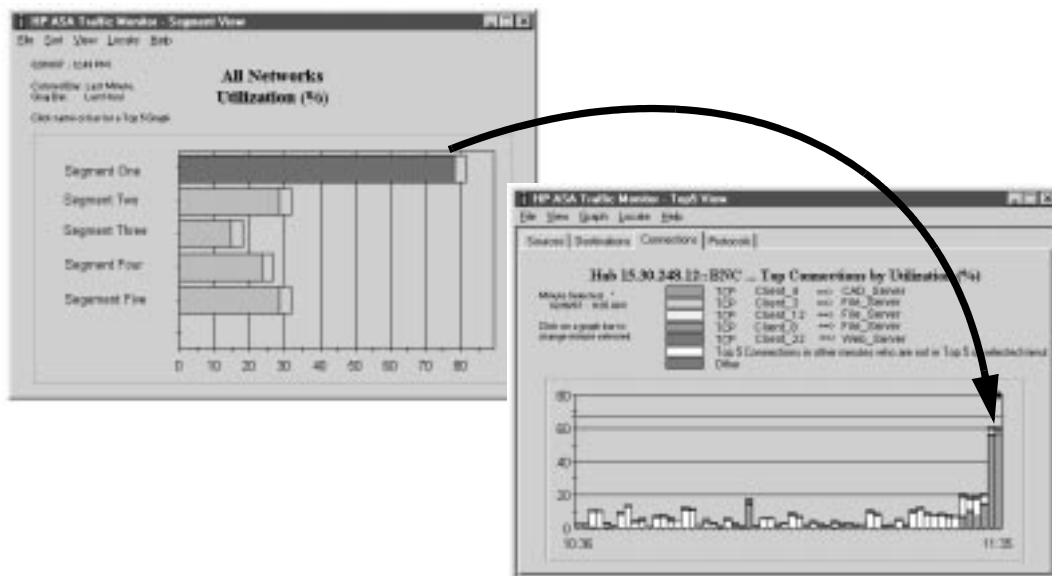

---

## Network Performance Advisor

Network Performance Advisor helps you optimize your network and manage its growth. After sampling traffic data on the network, it presents detailed recommendations using clear diagrams and plain language. Viewed with a Web browser, the recommendations may include moving nodes, using switching technologies, or adding 100Mbps upgrades to maintain peak performance in the network. The recommendations are delivered in two reports:

- **Reorganizing Your Current Equipment to Reduce Utilization:** Determines which nodes should be moved to other locations in the network to reduce the traffic passing over bridges, switches, and routers. This report is the most economical to implement, as it tells you what you can do without adding new devices to your network.
- **Adding or Upgrading Equipment to Reduce Utilization:** Attempts to reduce the average utilization to below 15% by splitting existing segments into two or more segments; if no such splits can be identified, it recommends where you can place a desktop switch to optimize each segment. The report also tells you if you have nodes anywhere in the network that require a dedicated segment. This report may recommend that you add additional equipment.

### System Requirements: Windows

Microsoft Windows NT, version 3.51 or later, or Microsoft Windows 95  
IBM PC-compatible computer;  
minimum 486/66 MHz  
24 Mbytes RAM for Windows 95;  
32 Mbytes RAM for Windows NT  
50 Mbytes available hard disk space  
Super VGA monitor and interface card  
Microsoft Windows-compatible mouse  
10Base-T, 10Base2, or 100VG LAN adapter card (NIC)

### System Requirements: OpenView/NT

Microsoft Windows NT, version 3.51 or later  
IBM PC-compatible computer;  
minimum Pentium 120 MHz  
32 Mbytes minimum RAM  
30 Mbytes available hard disk space  
Super VGA monitor and interface card  
Microsoft Windows-compatible mouse  
10Base-T, 10Base2, or 100VG LAN adapter card (NIC)

---

## Features

Simple yet comprehensive network control	HP AdvanceStack Assistant provides point-and-click management for HP hubs, bridges, and switches. The icon-based color graphic interface, device closeup views, context sensitive on-line help, and task-oriented documentation allow you to perform management tasks quickly and easily. Simplified management lets you keep your network running smoothly and avoid costly downtime.
Integrated multivendor management	When integrated with an HP OpenView management platform, HP AdvanceStack Assistant provides true multivendor network management. The HP OpenView management platform provides generic SNMP utilities and supports hundreds of HP and third-party applications.
Network Performance Advisor	Through intelligent data collection and reporting, the Network Performance Advisor analyzes your network and its traffic patterns and recommends specific actions you can take to improve performance. The actions it suggests range from moving nodes among existing segments to adding switching hardware to your network.
Traffic monitoring	Traffic Monitor lets you watch network traffic and identify problems using statistics gathered from HP devices located across the network. It graphically presents continuous information in five key areas: Frames, Utilization, Errors, Broadcasts, and Multicasts. You can use this information to spot problems quickly and pinpoint their causes.





Automatic device discovery	Automatically discovers SNMP/IP and SNMP/IPX devices on your network. Discovery on IP networks can be configured to use ARP cache address tables stored on HP devices, or SNMP sequential discovery of IP addresses. HP AdvanceStack Assistant for OpenView/Windows uses HP OpenView's discovery capabilities.
Friendly names	Quickly recognizable names can be given to any network device or end node.
Locate devices and end nodes	Use this feature anywhere in AdvanceStack Assistant to find any node or device by its IP network address or "friendly name". When found, you can highlight it in the Topology View or go straight to its close-up view, if available.
VLAN capability	Increase performance of VLAN-capable HP switches and switching hubs by creating any number of broadcast domains among the nodes connected to the device.
SNMP Management for HP AdvanceStack hubs	Adding a single HP SNMP module to an AdvanceStack hub, or chain of hubs, provides it with an SNMP agent and built-in EASE traffic sampling capabilities. AdvanceStack Assistant includes the hub chain in its display and allows SNMP proxy management.
Truly helpful documentation	AdvanceStack Assistant's online help system is context-sensitive and guides you through all the procedures connected with using the software. The online Users Guide provides useful information at the click of a browser button.

## Competitive Strengths

- **Included with managed HP devices at no extra cost:** Cutting-edge network management technology is within the reach of any network administrator.
- **Powerful traffic monitoring capabilities:** Lets you see what's going on from the network level down to the node level.
- **Network Performance Advisor tool:** AdvanceStack Assistant is the only software available that can provide explicit, fully explained recommendations to improve your network's performance.
- **Integrates with HP OpenView:** Works hand in hand with the widely used and respected HP OpenView network management solution to manage devices from HP and a wide variety of other vendors.



## Switches: Product Summary

Product Number	Description	
J3100B pg. 5-10	HP AdvanceStack Switch 2000 High-performance modular workgroup or backbone segment switch that supports major LAN technologies via slide-in modules	
J3245A pg. 5-14	HP AdvanceStack Switch 800T High-performance segment switch with eight 100Mbps ports, each supported by a UTP (100Base-TX) or fiber-optic (100Base-FX) transceiver. (Shipped with 4 TX transceivers installed.)	
J3177A pg. 5-18	HP AdvanceStack Switch 224T Low-cost workgroup switch with 24 10Mbps ports, one fixed 100Base-TX port, and a transceiver bay on the second high-speed port for media flexibility (transceiver must be purchased separately).	
J3175A pg. 5-18	HP AdvanceStack Switch 208T Low-cost workgroup switch with eight 10Mbps ports, one fixed 100Base-TX port, and a transceiver bay on the second high-speed port for media flexibility (transceiver purchased separately).	

Standard Ports	Transceiver Slots	Expansion Slots	Connectivity			Expansion Capabilities					Management			Software	Size
			Fiber	UTP	Thin Coax	10Base-T	100Base-T	Autosensing 10/100	100VG	10Base-FL	FDI and ATM	Includes AdvanceStack Assistant for Windows	RMON Support	SNMP/IP/IPX Management	Automatic Traffic Optimization Layer 3 Switching
None	Varies	6	■	■	■	■	■	■	■	■	■	■	■	■	■
4 100Base-TX	8 10/100 Base-T <sup>1</sup>	None	■	■			■	■				■	■	■	■
24 10Base-T 1 100Base-TX 1 xcvr slot	1 100Base-T	1	■	■	■ <sup>2</sup>	■	■					■ <sup>3</sup>	■	■	■
8 10Base-T 1 100Base-TX 1 xcvr slot	1 100Base-T	1	■	■	■ <sup>2</sup>	■	■					■ <sup>3</sup>	■	■	■
<sup>1</sup> 10/100 with UTP transceiver; 100-only with fiber transceiver. <sup>2</sup> With optional transceiver installed. <sup>3</sup> With HP J3178A Management Module															

---

## The HP AdvanceStack Family of Switches

Hewlett-Packard switches offer powerful, flexible, and cost-effective options while reducing complexity, *with key support that no other networking company can offer*—the manageability and proactive network optimization provided by HP AdvanceStack Assistant (ASA) management software (page 5-2). HP delivers the modularity and performance you need to build and grow a network through flexible, standards-based switched and shared 10Mbps and 100Mbps solutions that protect investment by delivering a smooth growth path to emerging technologies.

- All models use HP AdvanceStack Assistant (ASA), a comprehensive, easy-to-use network management package that leads the industry in features, capability, and performance. ASA is included at no extra cost with most AdvanceStack switch models.
- All models include ASIC-based technology for award-winning performance.
- The high-performance Switch 2000 and 800T models offer virtual LAN (VLAN), layer 3 switching and protocol filtering, IP multicast (IGMP), and multiswitch port-trunking.
- UTP and fiber connectivity is available for 10Base-T, 100Base-T, and 100VG technology options.
- All models reduce congestion. Selected models provide scaleable bandwidth through 100Mbit, FDDI, and ATM switching.
- All models are designed for plug-and-play operation. (Any of these switches begin operating as soon as they are connected to the network and to a power source.)
- All models support interoperability with other vendors' products through standards-based design.
- All models offer expansion features.
- All models fit by design into standard 19-inch racks.
- All models offer an industry-leading warranty.

---

## Why Switching?

**Workgroup networking demands higher bandwidth** as users increasingly share and access data across the network. More powerful workstations promote high-bandwidth networked applications using imaging, graphics, and multimedia. Where client-server applications are implemented, network traffic patterns are significantly impacted; congestion becomes a recurring problem, and servers become overloaded. In some cases, the LAN becomes a computing backplane for interconnecting clients on lower bandwidth workgroups to servers

accessed through higher bandwidth media. For example, depending on traffic, applications, and other factors, this 10Mbps network with distributed servers could experience significant congestion:

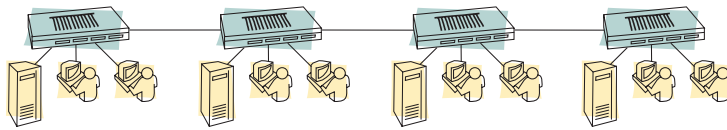

**Switches are tools for increasing bandwidth**, controlling traffic, and dispelling congestion. Using switches and their unique features, you can reserve dedicated bandwidth for specific servers and achieve high packet throughput to users and servers at a low cost per port. And, using switches enables you to preserve the investment in an existing LAN infrastructure while maintaining the ability to easily grow the LAN in the future. Switches can also add security within a LAN and in many cases, eliminate the need for a router within the LAN. (Routers still have a function on the “edge” of the LAN, providing security firewalls, internet access, and remote access.) Adding a 10/100Mbps switch to the above network gains these benefits:

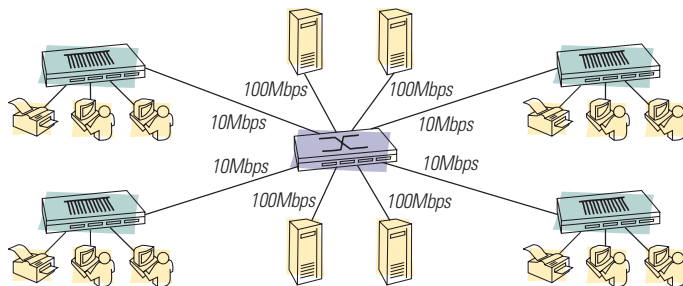

**Benefits of adding a switch:**

- Parallel access to servers over high-speed links
- Segments the network to eliminate unnecessary traffic and reduce or eliminate bottlenecks
- Large improvement at low cost

**An Ethernet LAN switch is a type of faster, multiport Ethernet bridge.** Unlike hubs, switches segment a LAN into separate collision domains and avoid sending traffic to ports where it is not needed. Switches use features such as full duplex, layer 3 switching, filtering, and IP Multicast control to increase bandwidth and control paths through a LAN. Some switches also provide fault tolerance through the port trunking.

**To summarize**, some common benefits of all switches is increased capacity, segmentation, parallel conversations, and LAN connectivity. Also, switches are typically simpler and easier to deploy into a network than a router. Because of this inherent simplicity, they are easier to manage and enable network performance upgrades while keeping the cost of ownership low.

**For more on switches**, refer to the chapter entitled “Switching Technology”.

## HP AdvanceStack Switch 2000

The HP AdvanceStack Switch 2000 is a high-performance modular department, backbone, or segment switch, offering six universal port expansion slots that support a number of connectivity options—10Base-T, 10Base-FL, 100Base-T, 100VG, FDDI, and ATM. This switch is designed to:

- connect to an enterprise backbone or operate as a collapsed backbone
- provide maximum flexibility and expansion capability by effortlessly supporting multiple media types/speeds and additions or changes through an easy-to-access modular design
- interconnect multiple segment switches, workgroup switches, hubs, centralized servers, and server farms
- provide security, fault tolerance, and scaleable traffic control

Switch 2000 Chassis  
with modules installed



The Switch 2000 can be configured with any combination of 10Mbps or 100Mbps interfaces to support 10Base-T, 100VG, 10Base-FL, and 100Base-T. It can also support up to two “high power” FDDI or ATM modules with any combination of the 10Mbps and 100Mbps modules.

- ready for HP AdvanceStack Assistant (ASA) management and console management (direct RS-232 console connect or telnet)
- offers powerful, built-in traffic optimization features—Layer 3 Switching, Layer 3 Protocol Filtering, Multimedia Traffic Control, Multimedia Priority Assist, Multiple Virtual LAN (VLAN) support, and Multiple-Switch Port Trunking

## Switch 2000 Product Features

Performance	The high-speed (1Gbps) bus and advanced ASIC design provide optimum performance and low latency
Up to 12 100Mbps (high speed) ports	Uses any combination of the two-port 100Base-T or 100VG modules (with associated transceivers)
Choice of network interfaces; up to 24 total ports	Mix and match interface and media types: <b>10Base-T Module:</b> Provides support for legacy 10Base-T Ethernet environments with four RJ-45 ports (half or full duplex) built-in and one transceiver bay for optional media alternative on port 1 (10Base-FL/FOIRL, 10Base-2 ThinLAN, or AUI transceiver) <b>100Base-T Module:</b> Provides the most raw bandwidth in switched environments and to servers using 10/100 Mbps UTP transceiver(s) or 100Mbps fiber transceiver(s), with two transceiver bays; half or full duplex. (Fiber transceiver uses SC connectors.) <b>10Base-FL Module:</b> Provides 10Base-FL support with four ports (fiber, ST-type connectors); half or full duplex <b>100VG Module:</b> Supports bandwidth sharing, end-to-end quality of service for time-sensitive, multimedia applications; with two transceiver bays (uses up to two 100VG transceivers, UTP or fiber with ST connector) <b>FDDI Module:</b> Supports one dual-attach station (DAS) port or two SAS ports; a high-power module—maximum of two high-power modules allowed in the switch <b>ATM Module:</b> Supports one-port ATM operation (OC-3, 155Mbps; based on UNI 3.0 and LANE 1.0 ATM standards); a high-power module—maximum of two high-power modules allowed in the switch
Complete management solution included	HP AdvanceStack Assistant for Windows management software provides traffic monitoring, real-time troubleshooting, and recommendations for improved performance.
Automatic Traffic Optimization software	Controls traffic flow to increase efficiency and stability on the network without router overhead
Layer 3 Switching	Manages broadcast domains without needing a router; stabilizes traffic by controlling broadcasts in a single- or multiple-network environment Supports media speed inter-subnet communication without needing high-cost 100Mbps router ports
Multimedia support IP Multicast (IGMP)	Dynamically allocates network bandwidth to support video servers and multimedia applications; supports IP Multicast (IGMP) control; includes Multimedia Priority Assist to enhance quality of service for video or multimedia applications
Optional Redundant Power Supply (RPS)	The HP J3136A RPS installs on the back of the Switch 2000
Interoperability	Standards-based design enables efficient inter-operation with equipment from other networking vendors
Warranty	Backed by lifetime (for as long as you own the product) warranty and next-business day advanced replacement, where available.

### Typical Uses

- Improve performance within legacy networks
- Migrate legacy networks to higher-speed technologies
- Optimize performance of new networks
- Serve as a consolidation and aggregation point for multiple LAN Technologies

10Base-T Module



100Base-T Module



10Base-FL Module

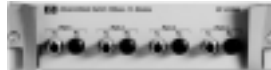

100VG Module

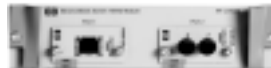

FDDI Module



ATM Module



**For More** on software advantages, fault tolerance, and increased bandwidth, see the white papers on HP's network reseller website at:

<http://www.hp.com/key/netreseller>

- Click on the Technology bar
- Select White Papers
- Go to Ethernet Switching for a list of Switching White Papers.

#### Switch Ordering Information

HP J3100B AdvanceStack Switch 2000

#### Accessory Ordering Information

##### Modules:

HP J3102A AdvanceStack Switch 2000 Ethernet Module

HP J3103A AdvanceStack Switch 2000 100VG Module

HP J3108A AdvanceStack Switch 2000 FDDI Module

HP J3109A AdvanceStack Switch 2000 10Base-FL Module

HP J3191A AdvanceStack Switch 2000 100Base-T Module

HP J3246A AdvanceStack Switch 2000 ATM Module

##### Transceivers:

HP J2606A AdvanceStack FOIRL Fiber-Optic Transceiver

HP J2607A AdvanceStack 10Base-T Twisted-Pair Transceiver

HP J2608A AdvanceStack 10Base2 ThinLAN Transceiver

HP J2609A AdvanceStack AUI Port Module

HP J3027A AdvanceStack Switch 2000 100VG Fiber-Optic Transceiver (ST)

HP J3028A AdvanceStack Switch 2000 100VG UTP Transceiver

HP J3192C AdvanceStack 10/100Base-TX Transceiver

HP J3193B AdvanceStack 100Base-FX Fiber-Optic Transceiver (SC connectors)

##### RPS:

HP J3136A AdvanceStack Redundant Power Supply

## Competitive Strengths

- **Flexibility:** Offers broad connectivity and media options (10Base-T, 100Base-T, 100VG, 10Base-FL, FDDI, and ATM). Twisted-pair, fiber, and ThinLAN are all available.
- **Growth and Investment Protection:** The Switch 2000 grows with the network, allowing initially unused slots to be filled when needed, enabling such conveniences as connectivity between legacy 10Mbps segments and new high-speed segments and moving servers from workgroups to faster, central connectivity or server farms.
- **ASIC-Based Fast-Forwarding Architecture:** Combines the benefits of both cut-through and store-and-forward switches to provide exceptionally low latency (less than 10ms). In addition, the Switch 2000 offers a bus speed of 1Gbps for high performance and scalability, and up to 12 100Mbps or 24 10Mbps switched ports in a single box.
- **Superior Network Monitoring and Management:** Use the industry-leading HP AdvanceStack Assistant (ASA) software (included with the switch at no extra cost), to provide an unparalleled combination of monitoring and management. ASA responds to changing network conditions. ASA monitors the network, finds problems, and makes recommendations for moving nodes, using switching technologies, and adding 100Mbps upgrades—all aimed at maintaining peak performance in your network. For more on the clear advantages of this industry-leading tool, refer to “Network Management” on page 5-2.
- **Powerful Software Advantages Optimize Network Traffic:**
  - Layer 3 Switching and Protocol Filtering:** Increase performance and move the need for a router to the “edge” of the LAN. The switch manages broadcasts and optimizes performance without needing a router. Protocol filtering blocks traffic in unneeded (or unwanted) protocols to save bandwidth security.
  - IP Multicast (IGMP):** Increases performance by preventing unwanted flooding of multicast video traffic and by prioritizing multimedia traffic. IGMP support and quality-of-service prioritization of traffic reduces network utilization and overhead on non-participants while delivering the levels of service needed by the latest applications.
  - VLANs for Traffic Reduction and Increased Security:** Using virtual LANs in the Switch 2000 provides isolation (“firewalls”) between workgroups while preserving the existing network structure. And the switch offers Spanning Tree (802.1d compliant) support for multiple VLANs.
- **Fault-Tolerance and Increased Bandwidth:** Multiswitch port trunking enables easy migration to higher speed switch-to-switch communications. Allows trunking of 100Mbps ports to create links to other Switch 2000s (J3100A or J3100B) and to the Switch 800T. With full-duplex operation, this enables up to 800Mbps of bandwidth between switches.

## Suggested Demonstration Features

- **Network Management:** Show how ASA effectively monitors and manages every port on the switch without the use of probes. Refer to “Network Management” on page 5-2 for more network management demo tips. Also, using ASA to show the results, you may find value in demonstrating the following Switch 2000 features:
  - the effect of layer-3 switching on a test network
  - the operation and effect of port trunking for increased bandwidth and fault tolerance
- **Flexibility:** Show and operate the Switch 2000 with various modules and transceivers installed. Demonstrate “hot-swapping” modules.

## More Competitive/Product Information

- **Competitive:** See the *Reseller Plaza* website at <http://www.hp.com/key/netreseller>
- **Product:**
  - HP Networking Products Data Sheet (p/n 5966-2253EUC)
  - HP AdvanceStack Assistant Emulator CD-ROM (p/n 5965-5979E)
  - HP Reseller Plaza website (URL shown above)
  - Manuals on the Network City website (URL shown above).

## Frequently Asked Questions

*Does the 100BT module ship with transceivers?*

**No.** Transceivers need to be ordered separately so that the customer can have whatever type is desired; UTP or Fiber.

*What is the difference between an “A” model and a “B” model?:*

“A” Version (J3100A)	“B” Version (J3100B)
New software advantages not included.	Layer-3 Switching IP Multicast (IGMP) support
Supports one port trunk group.	Supports up to six port trunk groups.
With release A.03.00 or later software, supports Multiple Instance Spanning Tree (one per VLAN) when VLANs are configured.	Multiple-Instance Spanning Tree (one per VLAN); available when VLANs configured.
With release A.03.00 or later software, installing a module in an unused slot does not need a reboot for default operation.	Installing a module in an unused slot does not need a reboot for default operation.
Reboot for: <ul style="list-style-type: none"> <li>• adding/deleting ports in a VLAN</li> <li>• enabling/disabling Spanning Tree or port trunks requires reboot</li> <li>• configuring monitor port or traffic filters</li> </ul>	No reboot needed after adding/deleting ports in a VLAN or enabling/disabling Spanning Tree or port trunks, or configuring monitor port or traffic filters.

### SPECIFICATIONS

#### ENVIRONMENTAL

Operating Temperature:  
0° to 55° C (32° to 131° F)  
Operating Relative Humidity:  
15 to 95% @ 40° C (104° F),  
noncondensing

#### PHYSICAL

Dimensions: 44 x 30 x 18 cm  
(17.3 x 11.8 x 7.0 in)

Weight: without modules or RPS:  
7.86 kg (17.3 lb)

#### ELECTRICAL

AC voltage: 100-127/200-240 volts  
Current: 2.5A max at 100-127 volts  
1.5A max at 200-240 volts  
Frequency: 50/60 Hz

### STANDARDS

#### COMMUNICATIONS

IEEE 802.1, IEEE 802.3, IEEE 802.12

#### SAFETY

EN 60950/IEC 950; UL 1950; CSA 950  
NOM-19-SCFI-1994

#### EMISSIONS

EN 55022/CISPR-22 Class A  
FCC Class A  
VCCI Level 1

#### IMMUNITY

Generic: EN 50082-1  
ESD: IEC 801-2 4kV CD, 8 kV AD  
Radiated: IEC 801-3 3 V/m  
EFT/Burst: IEC 801-4 1.0 kV  
(power line), 0.5 kV (signal line)



## HP AdvanceStack Switch 800T

The HP AdvanceStack Switch 800T is a high-performance segment switch offering eight 100Base-T transceiver bays designed to support any combination of either UTP (100Base-TX) or fiber-optic (100Base-FX) transceivers. It comes standard with four UTP transceivers installed.

- Ideal for server farm network connections, with dedicated high-speed links to individual servers or to hubs supporting servers in a shared environment.

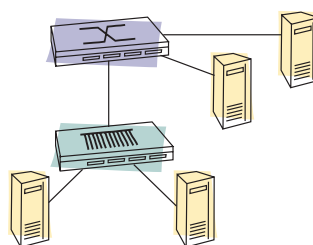

- Connect to an enterprise backbone or operate as a collapsed backbone in a smaller network by interconnecting multiple segment switches, workgroup switches, hubs, centralized servers, and server farms.
- From the base unit (four 10/100 UTP transceivers installed), expand to as many as eight high-speed ports.
- Provide security, fault-tolerance, and scalable traffic control through powerful software advantages and multi-switch port-trunking.



The Switch 800T offers:

- Operation with HP AdvanceStack Assistant (ASA) management—furnished at no extra cost—and console management (direct RS-232 console connect or telnet).
- Powerful traffic optimization features—Layer 3 Switching and Protocol Filtering, Multimedia Traffic Control and Priority Assist, Multiple Virtual LAN (VLAN) support, and Multiple-Switch Port Trunking.

## Switch 800T Product Features

Performance	The high-speed (1Gbps) bus and advanced ASIC design provide optimum performance and low latency
Expandable to 8 100Mbps (high speed) ports	Base unit includes four 100Mbps UTP transceivers Expand to 5, 6, 7, or 8 ports, as needed
Flexible media connectivity	Uses any combination of the HP J3192B (UTP) and HP J3193B (fiber) transceivers for flexible connectivity Each UTP port can operate at either 10Base-T or 100Base-TX; half or full duplex (or Auto-Detect if connected device complies with the 802.3u "Auto Negotiation" standard)
Complete management solution included	HP AdvanceStack for Windows management software provides traffic monitoring, real-time troubleshooting, and recommendations for improved performance.
Automatic Traffic Optimization software	Controls traffic flow to increase efficiency and stability on the network without router overhead
Layer 3 Switching	Manages broadcast domains without needing a router; stabilizes traffic by controlling broadcasts in a single- or multiple-network environment
IP Multicast (IGMP) Multimedia Support	Dynamically allocates network bandwidth to support video servers and multimedia applications; supports IP Multicast (IGMP) control; includes Multimedia Priority Assist to enhance quality of service for video or multimedia applications
Optional Redundant Power Supply (RPS)	The HP J2962A RPS allows connection of up to four devices for maximum uptime
Interoperability	Standards-based design enables efficient inter-operation with equipment from other leading networking vendors
Warranty	Backed by lifetime (for as long as you own the product) warranty and next-business day advanced replacement, where available.

## Competitive Strengths

- **ASIC-Based Fast-Forwarding Architecture:** Combines the benefits of both cut-through and store-and-forward switches to provide exceptionally low latency (less than 10ms). In addition, the Switch 800T offers a bus speed of 1Gps for high performance and scalability, and up to 8 100Mbps switched ports in a single box.
- **Superior Network Monitoring and Management:** Use the industry-leading HP AdvanceStack Assistant (ASA) software (included with the switch at no extra cost), to provide an unparalleled combination of monitoring and management. ASA responds to changing network conditions. ASA monitors the network, finds problems, and makes recommendations for moving nodes, using switching technologies, and adding 100Mbps upgrades—all aimed at maintaining peak performance in your network. For more on the clear advantages of this industry-leading tool, refer to "Network Management" on page 5-2.

### Typical Uses

- Operate as a segment switch to improve performance within legacy networks.
- Migrate 10Mbps networks to higher-speed technologies.
- Optimize performance of new networks.

**For More** on software advantages, fault tolerance, and increased bandwidth, see the white papers on HP's world wide web site at:

<http://www.hp.com/key/netreseller>

- "HP AdvanceStack Switch 2000: Fast Forwarding Architecture"
- Automatic Broadcast Control and Layer-3 Switching
- IP Multicast Control (IGMP)
- Hewlett-Packard Switch Port Trunking



<http://www.hp.com/key/netreseller>

#### Ordering Information

HP J3245A AdvanceStack Switch 800T

*The AdvanceStack Switch 800T comes installed with four UTP (10/100Base-TX) transceivers. Additional transceivers can be ordered separately.*

HP J3192C AdvanceStack 10/100Base-TX UTP Transceiver

HP J3193B AdvanceStack 100Base-FX Fiber-Optic Transceiver (SC connectors)

HP J2962A AdvanceStack Redundant Power Supply

#### ■ Offers a choice of media and bandwidth to provide customers with connection flexibility:

- Uses any combination of the HP J3192C (UTP) and HP J3193B (fiber) transceivers.
- Each UTP port can operate at either 10Base-T or 100Base-TX; half or full duplex (or Auto-Detect if connected device complies with the 802.3u “Auto Negotiation” standard).
- Each 100Mbps fiber port can operate at either full or half duplex.

#### ■ Powerful Software Advantages Optimize Network Traffic:

The Switch 800T is the only switch in its class that optimizes network traffic for increased performance and lower complexity for the network administrator.

- **Layer 3 Switching and Protocol Filtering:** Increase performance and move the need for a router to the “edge” of the LAN. The switch manages broadcasts and optimizes performance without needing a router. Protocol filtering blocks traffic in unneeded (or unwanted) protocols to save bandwidth and increase security.
  - **IP Multicast (IGMP):** Increases performance by preventing unwanted flooding of multicast video traffic and by prioritizing multimedia traffic. IGMP support and quality-of-service prioritization of traffic reduces network utilization and overhead on non-participants while delivering the levels of service needed by the latest applications.
  - **VLANs for Traffic Reduction and Increased Security:** Using virtual LANs in the Switch 800T provides isolation (“firewalls”) between workgroups while preserving the existing network structure. And the switch offers Spanning Tree (802.1d compliant) support for multiple VLANs.
- #### ■ Fault-Tolerance and Increased Bandwidth:
- Multiswitch port trunking enables easy migration to higher speed switch-to-switch communications. Allows trunking of 10Mbps or 100Mbps ports to create links to other Switch 800Ts and to the Switch 2000 (J3100A or J3100B).

---

## Suggested Demonstration Features

- **Network Management:** Show how ASA effectively monitors and manages every port on the switch without the use of probes. Refer to “Network Management” on page 5-2 for more network management. Also, using ASA to show the results, you may find value in demonstrating the following Switch 800T features:
  - The effect of Layer-3 switching on a test network (Use a traffic generator or video stream application to create traffic.)
  - The operation and effect of port trunking for increased bandwidth and fault-tolerance (Use a traffic generator on two or more nodes to create traffic.)
- **Flexibility:** Show and operate the Switch 800T with both UTP and fiber 100Mbps transceivers installed. Demonstrate both 100Base-T and 10Base-T connectivity.
- **Fault-Tolerance and Increased Bandwidth:** Demonstrate port trunking with another Switch 800T or with a Switch 2000. Use either 100Mbps or 10Base-T connections. Use the same media type, speed, and duplexing for all ports in a trunk. (See the port-trunking white paper on the Reseller Plaza website and the description of port trunking in the 800T *Installation and Configuration Guide*.)

---

## More Competitive/Product Information

- **Competitive:** See the *Reseller Plaza* on HP's Network City website at <http://www.hp.com/key/netreseller>
- **Product:**
  - HP Networking Products Data Sheet (p/n 5966-2253EUC)
  - HP AdvanceStack Assistant Emulator CD-ROM (p/n 5965-5979E)
  - HP Reseller Plaza website
  - Manuals on the Reseller Plaza website (URL shown above).

---

## Frequently Asked Questions

### *How many RJ-45 ports come with the switch?*

Four UTP transceivers are shipped (installed) with the 800T. Up to eight UTP or eight fiber or any combination of the two can be used.

### *What types of transceivers can be used in the switch?*

- HP J3192B AdvanceStack 10/100Base-TX Twisted-Pair Transceiver
- HP J3193B AdvanceStack 100Base-FX Fiber-Optic Transceiver

**Note:** Use only the “B”-version or later transceiver.

For more FAQs, see the Reseller Plaza website.

## SPECIFICATIONS

### ENVIRONMENTAL

Operating Temperature:

0° to 55° C (32° to 131° F)

Operating Relative Humidity:

15 to 95% @ 40° C (104° F),  
noncondensing

### PHYSICAL

Dimensions: 44 x 30 x 6.3 cm  
(17.3 x 11.8 x 2.5 in)

Weight (with four factory-installed

HP J3192C Transceiver Modules):  
4.3 kg (9.5 lb)

### ELECTRICAL

AC voltage: 100-127/200-240 volts

Current: 1.5A max at 100-127 volts  
0.75A max at 200-240 volts

Frequency: 50/60 Hz

### STANDARDS

#### COMMUNICATIONS

IEEE 802.1, IEEE 802.3, IEEE 802.3u

#### SAFETY

EN 60950/IEC 950; UL 1950; CSA 950  
NOM-019-SCFI-1994

#### EMISSIONS

EN 55022/CISPR-22 Class A

FCC Class A

VCCI Level 1

#### IMMUNITY

Generic: EN 50082-1

ESD: IEC 801-2 4kV CD, 8 kV AD

Radiated: IEC 801-3 3 V/m

EFT/Burst: IEC 801-4 1.0 kV  
(power line), 0.5 kV (signal line)



<http://www.hp.com/key/netreseller>

---

## HP AdvanceStack Switch 208T/224T

The HP AdvanceStack Switches 208T and 224T are manageable, plug-and-play desktop or top-of-stack switches that provide the performance and scalability of a backbone switch at a desktop price. These switches are designed for:

- switched 10Mbps performance to the desktop
- workgroups that require segmentation of shared hubs
- 100Mbps performance to servers or high performance segment or backbone switches

Switch 208T



Switch 224T



Choose from either 8 or 24 switched 10Mbps ports. Both switches offer one fixed 100Base-T port and one 100Mbps transceiver bay (for either a twisted-pair or fiber transceiver).

- To add management and the capability to select full duplex, simply insert the HP J3178A Management Module in the Switch Management Slot. (See “Network Management” on page 5-2.)
- To make either switch internet-ready, install the HP J3138A Internet Router in the Expansion Slot on the back panel.

## Switch 208/224 Product Features

Choice of 8 or 24 10Base-T Ports	High-speed bus supporting 8 or 24 RJ-45 switched 10Base-T ports
One fixed 100Base-TX port	Each switch provides 1 fixed RJ-45 100Base-TX port
One modular 100Mbps port with choice of transceivers	Each switch provides 1 high-speed port for either a 100Base-TX twisted-pair transceiver or a 100Base-FX fiber transceiver (SC connectors)
Two expansion slots, with Management and Internet-Ready option	Add network management and console management (direct RS-232 or Telnet) with the switch management module. Not required for unmanaged switches Enable internet access with the Internet Router module
Duplex Capability	Full-duplex (with Management Module installed) or half-duplex operation on all ports
Address Capacity	Both models hold over 8000 MAC addresses in the forwarding table, with up to 1000 addresses per port
Switch Stacking	Can be stacked with other 208/224 switches through either the 10Mbps or 100Mbps ports (See "Frequently Asked Questions" on page 5-21.)
Server Connectivity	Use any 10Mbps or 100Mbps port to provide a dedicated link to a server or a shared link to a server farm hub
Optional Redundant Power Supply (RPS)	The HP J2962A RPS allows connection of up to four devices for maximum uptime
Interoperability	Standards-based design enables the Switch 208 and 224 to interoperate efficiently with networking equipment from other leading networking vendors
Performance	1 gigabit bus and advanced ASIC design provide optimum performance and low latency
Warranty	Backed by lifetime (for as long as you own the product) warranty and next-business day advanced replacement, where available.
Protects Investment	In a growing network, these switches can move from the desktop to top-of-stack workgroup segmenting, as well as provide 100Mbps service on dedicated server links and to a backbone or server farm switch. They can also operate as 10Mbps server farms with 100Mbps links to the backbone to reduce congestion.

### Typical Uses

- In the wiring closet to segment a small number of pre-existing hubs, resulting in increased performance and responsiveness.
- As an ideal workgroup or desktop switch, used to simply and affordably connect end nodes in order to provide dedicated bandwidth to the desktop.
- As an upgrade to small networks that are just starting to segment existing shared environments to improve performance.
- As 10Mbps server farms with 100Mbps links to the backbone to reduce congestion.

#### Switch Ordering Information

HP J3175A AdvanceStack Switch 208T  
HP J3177A AdvanceStack Switch 224T

#### Accessory Ordering Information

HP J3178A Switch 208/224  
Management Module  
HP J3138A AdvanceStack Internet  
Router  
HP J3192C AdvanceStack 100Base-TX  
UTP Transceiver  
HP J3193B AdvanceStack 100Base-FX  
Fiber-Optic Transceiver (SC  
connectors)  
HP J2962A AdvanceStack Redundant  
Power Supply

## Competitive Strengths

- **Flexibility:** Both models offer economical, cost-effective top-of-stack or desktop functionality in a single unit, saving customers from buying a separate switch to support each type of use.

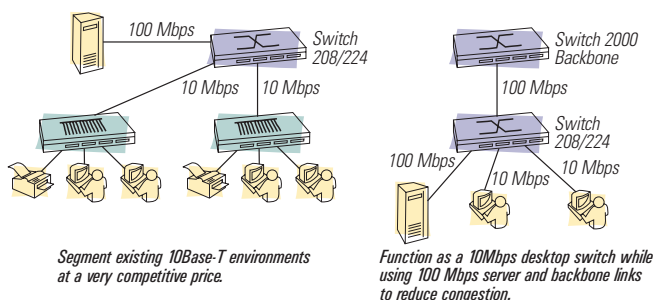

- **Superior Network Monitoring and Management:** Use the industry-leading HP AdvanceStack Assistant (ASA) software (included with the switch at no extra cost), to provide an unparalleled combination of monitoring and management. ASA responds to changing network conditions. ASA monitors the network, finds problems, and makes recommendations for moving nodes, using switching technologies, and adding 100Mbps upgrades—all aimed at maintaining peak performance in your network. For more on the clear advantages of this industry-leading tool, refer to “Network Management” on page 5-2.
- **Outstanding Address Availability:** Both switches support over 8000 addresses in the forwarding table, and up to 1000 per port.
- **Industry-Leading Price/Performance:** Lower cost of ownership.
- **Maximizes Performance:** Full-duplex operation is available on all 10Mbps and 100Mbps ports when a Management Module is installed.
- **Backed by lifetime** (for as long as you own the product) warranty and next-business day advanced replacement, where available.

## Suggested Demonstration Features

- **Flexibility:** Show the Switch 208/224 in both top-of-stack and desktop roles and point out that economical use of competitors’ products requires two separate devices for these roles.
  - Top-of-Stack demonstrates the switch’s segmenting capabilities.
  - Desktop demonstrates the switch’s workgroup capability. Use the 10Mbps ports for desktop nodes and the fixed 100Mbps port to support a server. If applicable, demonstrate the modular 100Mbps port as a twisted-pair or fiber link to a backbone switch.

---

## More Competitive/Product Information

- **Competitive:** See the *Reseller Plaza* website at <http://www.hp.com/key/netreseller>
- **Product:**
  - HP Networking Products Data Sheet (p/n 5966-2253EUC)
  - HP AdvanceStack Assistant Emulator CD-ROM (p/n 5965-5979E)
  - HP Reseller Plaza website (URL shown above)
  - Manuals on the Reseller Plaza website (URL shown above):
    - HP AdvanceStack Switch 208/224 Installation Guide
    - HP AdvanceStack Switch 208/224 Management Module Installation and Reference Guide

---

## Frequently Asked Questions

### *Is the Management Module required to do full duplex?*

**Yes.** There is no console on an unmanaged Switch 208/224, so there is no way to change the default configuration without the Management Module. The default configuration is that all ports are in half-duplex mode including the 100TX ports.

### *Is the Management Module required to use the Internet Router?*

**No.** The internet router module does not require the SNMP management module to function in the Switch 208/224. It runs completely independently and has its own console, SNMP agent and management. It only gets power (and access to the network through port 1) internally from the switch.

### *How does the Switch 208/224 do stacking?*

Switch 208/224 does stacking through normal network connections using the network ports (100Base-TX or 10Base-T). There is no separate or proprietary connector for stacking.

### *Is the Management Module necessary to do stacking?*

**No.** Since stacking is achieved by using normal networking ports (100TX or 10BaseT), no Management Module is required to stack or interconnect these switches. There is no port-trunking feature on the Switch 208/224 so the maximum bandwidth allowed between two unmanaged switches is 100 Mbps. If the Management Module is used then the ports may be configured to full duplex, resulting in a bandwidth of 200 Mbps between switches.

---

## SPECIFICATIONS

### ENVIRONMENTAL

Operating Temperature:  
0° to 55° C (32° to 131° F)

Operating Relative Humidity:  
15 to 95% @ 40° C (104° F),  
noncondensing

### PHYSICAL

Dimensions: 44.2 x 30.0 x 6.6 cm  
(17.4 x 11.8 x 2.6 in)

Weight: 4.5 kg (9.9 lb)

### ELECTRICAL

AC voltage: 100-127/200-240 volts

Current: 2.5 A; Frequency: 50/60 Hz

## STANDARDS

### COMMUNICATIONS

IEEE 802.1, IEEE 802.3, IEEE 802.3u

### SAFETY

EN 60950/IEC 950; UL 1950; CSA 950  
NOM-19-SCFI-1994

### EMISSIONS

EN 55022/CISPR-22 Class A

FCC Class A

VCCI Level 1

### IMMUNITY

Generic: EN 50082-1















ESD: IEC 801-2 4kV CD, 8 kV AD

Radiated: IEC 801-3 3 V/m

EFT/Burst: IEC 801-4 1.0 kV  
(power line), 0.5 kV (signal line)

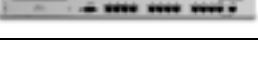
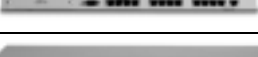
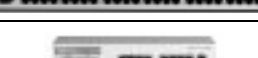

# Hubs: Product Summary

HP 10Base-T Hubs		
J3200A pg. 5-36	<b>HP AdvanceStack 10Base-T Switching Hub-12R:</b> Expandable 12-port 10BT stackable hub with multisegment architecture and slots for upgrading to advanced functionality.	
J3202A pg. 5-36	<b>HP AdvanceStack 10Base-T Switching Hub-24R:</b> Expandable 24-port 10BT stackable hub with multisegment architecture and slots for upgrading to advanced functionality.	
J3204A pg. 5-36	<b>HP AdvanceStack 10Base-T Switching Hub-24T:</b> Provides same functionality as HP J3202A Hub-24R, with two 12-port Telco connectors instead of RJ-45 ports.	
J3128A pg. 5-26	<b>HP AdvanceStack 10Base-T Hub-8E:</b> The most economical 8-port 10Base-T hub; easily expandable through 10Base-T cascading.	
J3300A pg. 5-26	<b>HP 10Base-T Hub 12:</b> Economical 12-port 10Base-T hub with one transceiver slot, and an MDI/MDI-X port for easy expansion.	
J3301A pg. 5-26	<b>HP 10Base-T Hub 12M:</b> Economical 12-port 10Base-T hub with built-in network management that can proactively find common network problems, and fix them if possible.	
J3302A pg. 5-26	<b>HP 10Base-T Hub 24:</b> Economical 24-port 10Base-T hub with one transceiver slot, and an MDI/MDI-X port for easy expansion.	
J3303A pg. 5-26	<b>HP 10Base-T Hub 24M:</b> Economical 24-port 10Base-T hub with built-in network management that can proactively find common network problems, and fix them if possible.	
J2610B pg. 5-26	<b>HP AdvanceStack 10Base-T Hub-8U:</b> Economical 8-port 10Base-T hub, upgrades to SNMP management.	
J2611B pg. 5-26	<b>HP AdvanceStack 10Base-T Hub-16U:</b> Provides same functionality as J2610B Hub-8U, with 16 RJ-45 ports instead of eight.	
HP AdvanceStack 100Base-T High-Speed Hubs		
J3233A pg. 5-30	<b>HP AdvanceStack 100Base-T Hub-12TXM with Management:</b> Stackable, SNMP managed 100BT hub with 12 RJ-45 ports (cat 5 UTP cable); switch port module expansion slot.	
J3234A pg. 5-30	<b>HP AdvanceStack 100Base-T Hub-12TX:</b> Stackable, manageable 100Base-T hub with 12 RJ-45 ports for cat 5 UTP cabling and expansion slot for switch port module.	
J3272A pg. 5-30	<b>HP AdvanceStack 100Base-T Hub-24TX:</b> Stackable, manageable 100Base-T hub with 24 RJ-45 ports for cat 5 UTP cabling and expansion slot for switch port module.	
J3235A pg. 5-30	<b>HP AdvanceStack 100Base-T Hub-8TXE:</b> Economical, Value Line 8-port 100Base-T hub with one cascading RJ-45 port for cat 5 UTP cabling. Can be cascaded to provide 14 100Mbps ports.	
HP AdvanceStack 100VG High-Speed Hubs		
J3137A pg. 5-34	<b>HP AdvanceStack 100VG Hub-7E:</b> Value Line 7-port 100VG hub for small standalone workgroups running in an Ethernet environment.	
J2415A pg. 5-34	<b>HP AdvanceStack 100VG Hub-14:</b> Expandable, stackable 14-port 100VG hub upgradable to full SNMP management, designed for high-performance workgroups.	

Ports			Media			Expansion			Management					Size	
10Base-T	100Base-T	100VG	Fiber	UTP	Thin Coax	Slot for Mgmt Module	Slot for Add-In Functionality	Stackable	Includes HP AdvanceStack for Windows	RMON Support	SNMP Mgmt	Security	Redundancy	Desktop (small footprint)	Standard 19" Rack Space
12			■*	■	■*	■	■	■	■	■	■	■	■		■
24			■*	■	■*	■	■	■	■	■	■	■	■		■
2 12-port Telco			■*	■	■*	■	■	■	■	■	■	■	■		■
8				■										■	
12			■*	■*	■*			■				■	■		■
12			■*	■*	■*			■	■	■		■	■		■
24			■*	■*	■*			■				■	■		■
24			■*	■*	■*			■	■	■		■	■		■
8			■*	■	■*	■			■		■			■	
16			■*	■	■*	■			■		■				■
	12		■*	■			■	■	■		■				■
	12		■*	■			■	■			■				■
	24		■*	■*			■	■			■				■
	8			■										■	
		7		■										■	
1*		14	■*	■*	■*	■	■	■	■		■	■	■		■

\*Available through add-in transceiver or expansion module.

---

## The HP Family of Hubs

Hewlett-Packard standards-based hub products combine plug-and-play hardware with easy-to-use network management software.

### Hub Definitions

- **Managed hub:** Includes the SNMP management hardware and agent.
- **Manageable hub:** When stacked with a managed hub, becomes an SNMP managed hub.
- **Master managed hub:** Managed hub that is automatically selected to manage all ports in a stack.
- **Backup management hub:** Any additional managed hubs in a stack. Automatically manages all ports in a stack if the master management stops responding.

### Hub Family Features

- A key benefit that no other networking company can offer: All managed hub models use HP AdvanceStack Assistant (ASA), a comprehensive, easy-to-use network management package that leads the industry in features, capability, and performance. It fully integrates with industry-leading HP OpenView for management of multivendor environments and supports RMON, EASE, IP, IPX, and MIB I and II. Included in ASA is the all-new Network Performance Advisor which makes detailed recommendations for network improvement. ASA is included at *no extra cost* with all AdvanceStack managed hub models.
- Most models offer expansion features. Build and grow networks through switched and shared 10Mbps and 100Mbps solutions that ensure a smooth growth path to emerging technologies.
- Designed to provide customers with sensible, painless upgrade options. Switching hubs are segmentable and stackable to offer better scalability and performance. High-speed and 100VG hubs are stackable and some include expansion slots for scaleable and flexible performance.
- UTP, fiber, thin coaxial, and AUI connectivity is available for switching 10Base-T hubs.
- All models are designed for plug-and-play operation. (Any of these hubs begin operating as soon as they are connected to the network and to a power source.)
- All models support interoperability with other vendors' products through standards-based design.
- Most models are designed to fit into standard 19-inch racks. Compact desktop models are designed to operate in locations where space is at a premium.

## HP's 10Base-T Switching Hub Features

HP has improved on an already superior product, the HP AdvanceStack 10Base-T Switching Hub, with support for all nine groups of RMON and load balancing for external switches.

- All nine groups of RMON are now available on all four segments of the HP AdvanceStack 10Base-T Switching Hub simultaneously. This provides network administrators the tools to dig deeply into network issues with detailed troubleshooting and historical information.
- The new HP AdvanceStack 10Base-T Switching Hubs now have automatic configuration and automatic port load balancing for external switches connected to HP AdvanceStack 10Base-T Switching Hubs. This allows users the flexibility to choose between using an external switch or the internal HP J3212A AdvanceStack 10Base-T Switch Module. This makes an already flexible product even more beneficial when designing or redesigning networks.

**RMON:** This is an embedded remote monitoring feature that uses hardware, agent firmware, SNMP (Simple Network Management Protocol), and management applications to provide detailed troubleshooting and historical information to the user by sampling all network data packets on a segment. There are nine groups of RMON and the inclusion of any of them constitutes an RMON-compliant product. There are also proprietary extensions that may be included to provide vendor-specific functionality. The nine groups of RMON supported by the 10Base-T Switching Hubs shown to the right.

**Note:** The upper five groups of RMON are available with or without using an optional 8MB memory SIMM in the HP J3210A AdvanceStack 10Base-T Management Pack. Without the SIMM, the size of the tables and packet capture are very small. Also, when the optional SIMM is present, some default host and matrix studies are automatically started.

The 8MB SIMMs can be purchased from many personal computer distributors. The SIMM specifications are:

- 8MB
- 72-pin
- 70 nanosecond

Do *not* use EDO memory.

**External Switch AutoConfig and Load Balancing:** The new HP AdvanceStack 10Base-T Switching Hub AutoConfig and Load Balancing features allow it to work with external switches. The AdvanceStack 10Base-T Switching Hub feature allows users to configure the switch explicitly via the AdvanceStack Assistant/console feature. In addition, the AutoConfigPorts to Segments feature will work across user configured segments for the switch. Load balancing will be available to the user on-demand, depending on how it is configured by the user.

### Updating Existing Switching Hub Installations to the New Features

Switching hubs with a firmware release of A.02.01 or later already include these features. If you have switching hubs with a firmware version prior to A.02.01 and you want these features, you can download the newest upgrade "shub0201.exe" from HP's Network City website on the world wide web at:

[http://www.hp.com/go/network\\_city](http://www.hp.com/go/network_city)

### The Nine Groups of RMON

1. **Statistics:** A collection of counters on each segment.
2. **History:** Samples in time of the Statistics group.
3. **Alarm:** A watchdog of objects in the MIB that can trigger an Event.
4. **Event:** Associates an action with an Alarm or network condition.
5. **Hosts:** Statistics on a per node basis.
6. **HostTopN:** Ranked Statistics per node.
7. **Matrix:** Tables for conversations between nodes.
8. **Filter:** Ability to redirect certain packets into a channel for other analysis.

**Capture:** Store packets for viewing later.

## HP 10Base-T Value Line Hubs

### Typical Uses for These Low-Cost Hubs

**Hub-16U, 12:** Ideal for incremental expansion of an existing network or for small, standalone networks and low-density distributed segments needing connection to a backbone.

**Hub 12M, 24M:** Ideal for integrating proactive networking with network management into a 10Base-T network.

**Hub-8U:** Ideal for small, standalone networks and low-density distributed segments.

**Hub-8E:** Ideal for cost-sensitive, small standalone networks and low-density distributed segments where future network management is not a consideration.

Economical, Value Line HP AdvanceStack 10Base-T hubs provide true plug-and-play installation with no special configuration requirements. The 10Base-T Hub 12M and the 10Base-T Hub 24M have built-in management features. The Hub-8U and -16U can be upgraded to SNMP with remote management capabilities. And the compact footprint of the Hub-8E and -8U enables easy setup in locations where space is limited.

Choose from these seven models:

- **Hub 12:** This 12-port 10Base-T unmanaged hub offers “plug-and-forget” operation. It also includes an MDI/MDI-X port for easy hub-to-hub cascading. It fits in a standard 19-inch rack with a slim 1.5 inch profile.
- **Hub 12M:** Network management is included in this 10Base-T hub. It supports SNMP, MIB II, full RMON (all nine groups), HP EASE, traffic monitoring and fault isolation. With 12 Base-T ports, a transceiver slot for media flexibility, and one MDI/MDI-X port for easy hub-to-hub cascading, the 10Base-T Hub 12M also includes proactive networking features such as AdvanceStack Assistant network management software, web-based management capabilities, and advanced troubleshooting including autopartitioning for fault isolation. It fits in a standard 19-inch rack with a slim 1.5 inch profile.
- **Hub 24:** This 24-port 10Base-T unmanaged hub offers “plug-and-forget” operation. It also includes an MDI/MDI-X port for easy hub-to-hub cascading. It fits in a standard 19-inch rack with a slim 1.5 inch profile.
- **Hub 24M:** Network management is included in this 10Base-T hub. It supports SNMP, MIB II, full RMON (all nine groups), HP EASE, traffic monitoring and fault isolation. With 24 Base-T ports, a transceiver slot for media flexibility, and one MDI/MDI-X port for easy hub-to-hub cascading, the 10Base-T Hub 24M also includes proactive networking features such as AdvanceStack Assistant network management software, web-based management capabilities, and advanced troubleshooting including autopartitioning for fault isolation. It fits in a standard 19-inch rack with a slim 1.5 inch profile.
- **Hub-16U:** This upgradable, 16-port 10Base-T hub includes one MDI/MDI-X port, a slot for an optional SNMP module, and a transceiver slot for media flexibility. Fits in standard 19-inch rack mount form factor.
- **Hub-8U:** This upgradable, 8-port 10Base-T hub is the lowest entry point for a manageable device. It includes an MDI/MDI-X port and the same SNMP module and transceiver options as the Hub-16U, all in a small footprint to fit conveniently into any desktop environment.

**For More** on using Value Line 10Base-T hubs in a network, go to the Technology area of the HP Reseller Plaza website at:  
<http://www.hp.com/go/netreseller>

- **Hub-8E:** This unmanaged hub offers “plug-and-forget” operation (with no special configuration needs), eight 10Base-T ports, one BNC port, and is easily expandable through 10Base-T cascading. Included is one daisy-chain port (MDI switch/port) for standard UTP connections between hubs without needing crossover cables. The small (19.0 cm by 11.6 cm; 7.5 in by 4.6 in) footprint fits conveniently into any desktop environment.

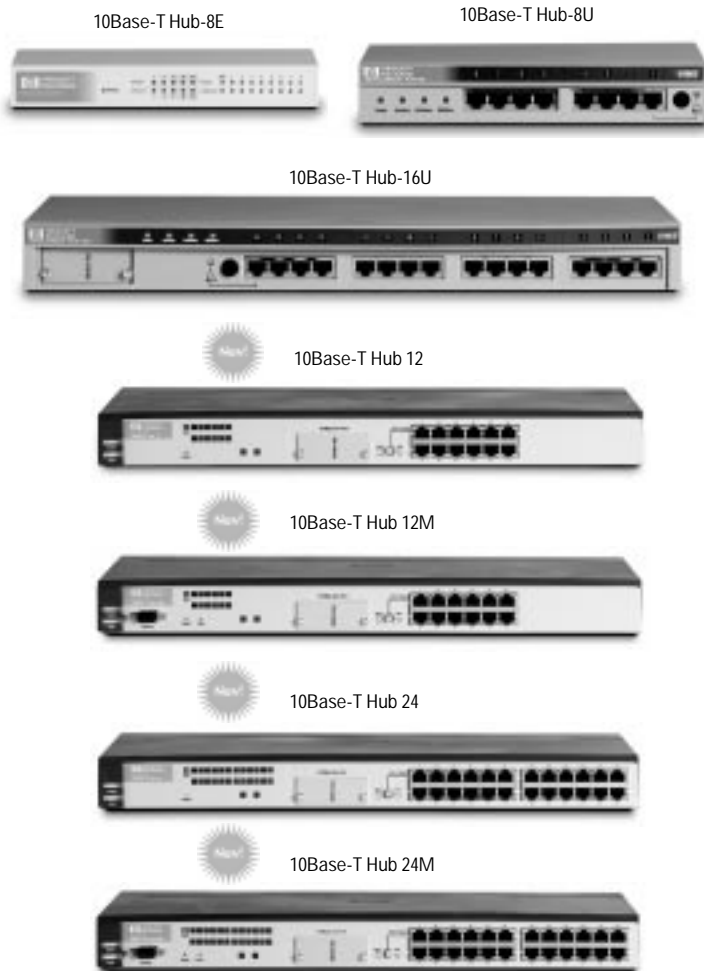

- **Adding Management to the Hub-16U and Hub-8U:** Adding the optional HP J3133A AdvanceStack 8U/16U SNMP Module creates an advanced network management solution having remote management capabilities. The SNMP module includes industry-leading HP AdvanceStack Assistant software at no extra cost. This provides full support for SNMP and EASE. Included also is Network Performance Advisor, which provides valuable recommendations on moving nodes, using switching technologies, and adding 100Mbps upgrades to maintain peak network performance.

#### Ordering Information

##### Hubs and SNMP Module

HP J3300A 10Base-T Hub 12  
HP J3301A 10Base-T Hub 12M  
HP J3302A 10Base-T Hub 24  
HP J3303A 10Base-T Hub 24M  
HP J3128A AdvanceStack 10Base-T Hub-8E  
HP J2610B AdvanceStack 10Base-T Hub-8U  
HP J2611B AdvanceStack 10Base-T Hub-16U  
HP J3133A AdvanceStack 8U/16U SNMP Module

##### Hub/SNMP Bundles

HP J3135A AdvanceStack 10Base-T Hub-16U/SNMP Bundle (includes J2611B and J3133A)  
HP J3134A AdvanceStack 10Base-T Hub-8U/SNMP Bundle (includes J2610B and J3133A)

##### Transceivers

HP J2606A AdvanceStack Fiber-Optic Transceiver Module  
HP J2607A AdvanceStack Twisted-Pair Transceiver Module  
HP J2608A AdvanceStack ThinLAN Transceiver Module  
HP J2609A AdvanceStack AUI Port Transceiver Module

**SPECIFICATIONS**

**ENVIRONMENTAL**

Operating Temperature,  
Hub-8E: 5° to 40° C (40° to 104° F)  
Hub-8U, Hub-16U, Hub-12, Hub-24, Hub-24M,  
Hub-24M:  
0° to 55° C (32° to 131° F)  
Operating Relative Humidity:  
15 to 95% @ 40° C (104° F),  
noncondensing

**PHYSICAL**

Dimensions:  
Hub-8E: 19.0 x 11.6 x 2.5 cm  
(7.5 x 4.6 x 1.0 in)  
Hub-8U: 21.6 x 17.0 x 4.1 cm  
(8.5 x 6.7 x 1.6 in)  
Hub-16U: 42.5 x 23.8 x 4.4 cm  
(16.7 x 9.4 x 1.7 in)  
Hub 12, 12M, 24, 24M:  
44.4 x 19.7 x 4.4 cm  
(17.5 x 7.8 x 1.7 in)

**Weight:**

Hub-8E: .64 kg (1.41 lb)  
Hub-8U: 1.45 kg (3.2 lb)  
Hub-16U: 2.2 kg (4.8 lb)  
Hub 12, 12M, 24, 24M: 2.4 kg (5.3 lb)

**ELECTRICAL CHARACTERISTICS**

Hub-8E:  
AC voltage: 100-127/200-240 volts  
Current: 0.8A max at 100-127 volts  
0.38A max at 200-240 volts  
Frequency: 50/60 Hz

Hub-8U:  
AC voltage: 100-127/200-240 volts  
Current: 0.28A max at 100-127 volts  
0.12A max at 200-240 volts  
Frequency: 50/60 Hz

Hub-16U:  
AC voltage: 100-127/200-240 volts  
Current: 0.3A max at 100-127 volts  
0.2A max at 200-240 volts  
Frequency: 50/60 Hz

Hub 12, 12M, 24, 24M  
AC voltage: 100-127/200-240 volts  
Current: 0.5A max at 100-127 volts  
0.3A max at 200-240 volts  
Frequency: 50/60 Hz

**STANDARDS**

**COMMUNICATIONS**

IEEE 802.3 Type 10Base-T  
IEEE 802.3 Type 10Base-2 (Hub-8E)  
RFC 1368 IEEE repeater MIB & MIB II  
(Hub-8U, Hub-16U, Hub 12M, Hub 24M)

**SAFETY**

EN 60950/IEC 950; UL 1950; CSA 950  
NOM-019-SCFI-1994 (Hub-8E, 8U, 12, 12M,  
24, 24M)

NOM-001-SCFI-1993

**EMISSIONS**

Hub 8E, 16U, 8U With shielded cables:  
EN 55022/CISPR-22 Class B)  
FCC Class B; VCCI Level 2  
Hub 12, 12M, 24, 24M With shielded cables  
FCC part 15 Class A  
EN 55022/CISPR-22 (1985) Class A  
VCCI Class A

**IMMUNITY**

Generic: EN 50082-1  
ESD: IEC 801-2 4kV CD, 8 kV AD  
Radiated: IEC 801-3 3 V/m  
EFT/Burst: IEC 801-4 1.0 kV  
(power line), 0.5 kV (signal line)

**Value Line 10Base-T Hub Features**

Proactive networking	The 12M and 24M hubs can proactively find common network problems—including chattering NICs, bad cables, and incorrect network topologies—and fix them, if possible, while keeping you informed.
Maintain control of your network with easy network expansion	Connect additional hubs through a cascade connection (MDI) or through a ThinLAN coaxial (BNC) connection. (The Hub-8E includes a BNC connector; the Hub-16U, 8U, 12, 12M, 24, and 24M include a transceiver slot that accepts an optional ThinLAN transceiver.)
Daisy chain or MDI port	Provides standard twisted-pair connections between hubs without special crossover cables.
LEDs	Power, activity, collisions, AUI/Xcvr, and Per Port status LEDs enable quick hub status checks and troubleshooting support.
Error correction and troubleshooting	Provides automatic port/segment partitioning and reconnection, plus automatic polarity detection and correction on UTP ports.
Upgradable and flexible (Hub-16U and Hub-8U)	These hubs both offer the options of adding an SNMP module for management and a recessed transceiver for media flexibility, including fiber optic, coaxial (BNC), UTP, and AUI.
Complete network management solution included with 12M and 24M	Supports SNMP, MIB II, full RMON (all nine groups), HP EASE, traffic monitoring and fault isolation. Hub-level and port-level security features: intruder prevention, auto port disabling, network management alarm, eavesdrop protection, authorized managers list, assigned port access, and password protection.
Full SNMP management with the optional SNMP module and AdvanceStack Assistant (Hub-16U and -8U)	Network Performance Advisor for detecting the need for network changes to maintain top performance. Hub-level and port-level security features: intruder prevention, auto port disabling, network management alarm, eavesdrop protection, authorized managers list, assigned port access, and password protection. Management via Telnet, modem, or direct RS-232 connection. Intelligent error monitoring and partition recovery.
Standard SNMP MIB browser	Allows management from any management station.
Warranty	Backed by lifetime (for as long as you own the product) warranty and next-business day advanced replacement, where available.

---

## Competitive Strengths

- **All:** Low price-per-port for managed or unmanaged hub.
- **All:** Backed by lifetime (for as long as you own the product) warranty and next-business day advanced replacement, where available.
- **Hubs 12M and 24M:** Built-in proactive networking—complete network management included for a low price-per-port cost
- **Hubs 8E, 12, and 24:** Offers extensive front-panel LEDs.
- **Hubs 16U and 8U:** With optional SNMP module inserted, offers security features such as notification and auto-port disable.
- **Hubs 16U, 8U, 12M, and 24M:** Industry-leading software support with HP OpenView and HP AdvanceStack Assistant.



## HP AdvanceStack 100Base-T Hubs

The HP AdvanceStack 100Base-T Stackable Hubs and accessories offer industry-standard, high-performance shared 100Mbps (fast Ethernet) networking. These hubs are fully interoperable with HP's current offering of 100Base-T switches and LAN adapters, and with most industry standard networking products. These hubs can significantly improve network performance and simplify delivery of 100Mbps performance to every node, if desired.

**Options:** Choose from four models—the low-cost, 8-port unmanaged hub; the 24-port unmanaged stackable hub; the stackable, expandable 12-port manageable hub; or 12-port managed hub.

Hub-8TXE (unmanaged)



Hub-12TXM (managed)  
and  
Hub-12TX (manageable)



Hub-24TX



- **Hub-8TXE** offers true plug-and-play installation with a comprehensive LED display for hub status and network activity, plus simple management and troubleshooting.
- **Hub-24TX** is an unmanaged hub that can be stacked with the Hub-12TX or the Hub-12TXM for either managed or unmanaged workgroups. It offers a comprehensive front panel display for activity, utilization, and collision rate, plus simple management and troubleshooting. It features an expansion slot for Switch Port Modules to increase throughput and extend the distance to network device.
- **The Hub-12TXM, Hub-12TX, and Hub-24TX:** feature an expansion slot for either a 10/100Base-TX or 100Base-FX Switch Port Module:
  - The 10/100Base-T Module increases throughput to other network devices or connects the hub to a 10Base-T network device.
  - The 100Base-FX Module increases throughput to other network devices *and* extends the distance allowed to another device. (Maximum distance: up to 2000m–2km.)
- **The Hub-12TXM:**
  - Includes SNMP management with support for Ethernet and Repeater MIBs, and MIB 2. Enables compatibility with industry-leading HP OpenView professional suite for workgroup management.

- Allows in-band access to the hub console through HP AdvanceStack Assistant (included at no extra cost) or Telnet.
  - Supports EASE traffic monitoring when connected via a *shared* port to an EASE-enabled switch, such as the Switch 2000, 800T, or 224T.
- **The Hub-12TX/24TX:** Becomes an SNMP-managed hub when stacked with a Hub-12TXM or other managed hub.

## 100Mbps Hub Features

<b>All:</b> Industry-standard	Based on IEEE 802.3u Fast Ethernet standard.
<b>All:</b> MDI/MDI-X port	Enables easy connections between hubs and switches without the need for a crossover cable.
<b>All:</b> Error correction	Automatic partitioning and reconnection increases availability.
<b>All:</b> UTP cabling	Category 5 shielded or unshielded twisted-pair cable.
<b>All:</b> Warranty	Backed by lifetime (for as long as you own the product) warranty and next-business day advanced replacement, where available.
<b>8TXE:</b> Class II cascadeable	Daisy-chain port for cascading with straight-through cable to provide a total of 14 ports of 100Mbps performance in each workgroup segment
<b>8TXE:</b> Compact design	Easy, plug-and-play setup in the desktop environment
<b>12TX/TXM, 24TX:</b> Stackable, with segmenting option	Up to 5 12TX/TXM hubs in a stack; up to 5 segments per stack (using the optional 10/100Base-TX or the 100Base-FX Switch Port Module); up to 60 ports per stack
<b>12TX/TXM, 24TX:</b> Console access	Management and monitoring via direct-connect RS-232 cable (included), modem, or in-band via Telnet. (In-band access requires one Hub-12TXM in the stack.)  Out-of-band control and configuration, including IP and IPX Ping, and Link test.
<b>12TX/TXM, 24TX:</b> Configurable	Redundant port assignment, intrusion control, and TFTP download mode accessible via the console access
<b>12TX/TXM, 24TX:</b> Management	SNMP v1 MIB Support: MIB-II, RFC 1573 MIB, Repeater MIB, Discovery and Topology objects Protocols: SNMP agent-manageable with TFTP and Zmodem/Xmodem support for agent upgrades
<b>Note:</b> Requires a Hub-12TXM in the stack	
<b>12TX/TXM, 24TX:</b> Optional switch port modules	100Mbps full- or half-duplex 10/100Base-TX via auto-negotiation  Network bridging: Line speed filtering and forwarding, automatic address learning  Switching method: Adaptive cut-through (dynamically changes between cut-through, fragment-free cut-through, and store-and-forward based on traffic  Address table: 4K entries per port  Latency: Less than 20 microseconds  Fiber module: 100Mbps full- or half-duplex 100Base-FX; 50/125µm or 62.5/125µm multimode fiber; one SC-type port  100Base-TX module: Full- or half-duplex 10/100Base-TX via auto-negotiation; UTP category 5 cable for 100Mbps; category 3, 4, or 5 for 10Mbps; 2 10/100Base-TX autosensing RJ-45 ports; one MDI and one MDI-X

### Typical Uses

- **Hub-8TXE:** Ideal for use in server farms and small workgroups with network applications such as database access, file sharing, electronic mail, and server-based application sharing.
- **Hub-12TX, Hub-12TXM, Hub-24TX:** Ideal for use in server farms and medium-to-large workgroups where network management and network applications such as database access, file sharing, electronic mail, and server-based application sharing are used.

**For More** on using 100Base-T hubs in a network, see “Upgrading to High Speed” in chapter 6, “Improving Network Performance” of the Network Design Guide. To access this article, visit the Reseller Plaza website at:

<http://www.hp.com/go/netreseller>

#### Ordering Information

##### 100Base-T Hubs:

HP J3233A AdvanceStack 100Base-T Hub-12TXM

HP J3234A AdvanceStack 100Base-T Hub-12TX

HP J3272A AdvanceStack 100Base-T Hub-24TX

HP J3235A AdvanceStack 100Base-T Hub-8TXE

##### Switch Port Modules:

HP J3247A AdvanceStack 10/100Base-TX Switch Port Module

HP J3248A AdvanceStack 100Base-FX Switch Port Module



<http://www.hp.com/key/netreseller>

---

## Competitive Strengths

### Hub-8TXE:

- Comprehensive front-panel display for simple management and troubleshooting.
- High network availability and reliability.
- Industry-standard 100Base-T offers performance and interoperability.
- Backed by lifetime (for as long as you own the product) warranty and next-business day advanced replacement, where available.

### Hub-12TX, Hub-12TXM, and Hub 24TX:

- Full-duplex port modules to increase throughput (up to 200Mbps) and allow a distance of up to 2000m (2km) to network devices.
- Full range of stackable hubs and accessories designed with the flexibility to build managed and unmanaged workgroups at the lowest possible cost.
- Managed hubs and accessories that are fully supported by HP OpenView professional suite for workgroup management, including HP AdvanceStack Assistant at no extra cost.
- Backed by lifetime (for as long as you own the product) warranty and next-business day advanced replacement, where available.

---

## Suggested Demonstration Features

- **Distance Capability Over Fiber Media:** Show the HP J3248A 100Base-FX Switch Port Module installed in the Hub-12TXM and Hub-12TX.
- **Increased Throughput to Network Devices Such As Servers and Switches:** Show the full- and half-duplex connections available through the HP J3247A (10/100Mbps UTP) and HP J3248A (100Mbps fiber) Switch Port Modules.
- **Plug-and-Play Connectivity with 10Base-T Legacy Systems:** Take advantage of the 10/100 autosensing capability in the HP J3247A Switch Port Module to connect to an existing 10Base-T workgroup.

---

## More Competitive/Product Information

- **Competitive:** See the Reseller Plaza website.
- **Product:**
  - HP Networking Products Data Sheet (p/n 5966-2253EUC)
  - HP Reseller Plaza website (URL shown above)
  - Manuals on the Reseller Plaza website (URL shown above).

## Frequently Asked Questions

*Does the introduction of shared 100Base-T products indicate a change in support for 100VG?*

No. The addition of shared 100Base-T products provides greater depth to the HP offering of high-performance networking products, where HP is already one of the top vendors. This product offering is consistent with HP's philosophy of offering products based on industry standards so that customers can make a choice based on their specific needs. HP will continue to support 100VG products, particularly for multimedia performance where the technology outperforms the competition.

*Can I use my 10Base-T Switching Hub switch module in the 100Base-T hubs?*

No. The 100Base-T Switch Port Module provides a single switch port to connect to other 100Base-T hubs, switches, routers, and servers. It does not allow individual ports on the hub to be associated with different segments, as is the case with the 10Base-T Switching Hub switch module.

*Can I use my 10Base-T stacking cable on my 100Base-T stackable hubs?*

No. The cables are unique and are supplied with each hub.

*Do I need to have 10/100TX LAN adapters in all my workstations and servers?*

You need to have 10/100 TX adapters in the devices you want to connect to the 100Base-TX ports on these hubs. They may use the 10/100TX switch port module to connect to a single 10Base-T-only device.

*Do the 100Base-T hubs have EASE agents?*

No. The hubs do not have an EASE agent. But the benefits of EASE and Traffic Monitoring are available when the hubs are connected to a switch that supports EASE, such as the Switch 2000, Switch 800T, Switch 224T, and Switch 208T.

*Do the 100Base-T hubs support Eavesdrop Prevention?*

No.

### SPECIFICATIONS

#### ENVIRONMENTAL

Operating Temperature:

5° to 40° C (40° to 104° F)

Operating Relative Humidity:

15 to 80% @ 40° C (104° F),  
noncondensing

#### PHYSICAL

Dimensions

Hub-8TXE:

27.9 x 17.8 x 4.3 cm (11 x 7 x 1.7 in)

Hub-12TX, Hub-12TXM, Hub-24TX:

43.8 x 30.5 x 6.4 cm

(17.25 x 12 x 2.5 in)

Weight

Hub-8TXE Weight: 1.7 kg (3.74 lb)

Hub-12TX: 4.9 kg (10.7 lb)

Hub-12TXM: 5.3 kg (11.7 lb)

Hub-24TX: 4.1 kg (9.1 lb)

#### ELECTRICAL

AC voltage: 100-127/200-240 volts

Current:

Hub-8TXE: 1.0 A max/1.0 A max

Hub-12TX/12TXM/24TX: 1.5-A max/

1.0 A max

Frequency: 50/60 Hz

### STANDARDS

#### COMMUNICATIONS

Hub-8TXE: IEEE 802.3u

100Base-TX Class II Repeater

Hub-12TX/12TXM/24TX: IEEE 802.3u

100Base-TX Class 1 Repeater

#### SAFETY

EN 60950; UL 1950;

CSA 950; NOM-019-SCFI-1994

#### EMISSIONS

EN 55022/CISPR-22 Class A

FCC Class A; VCCI Class A

#### IMMUNITY

Generic: EN 50082-1 (1992)

ESD: IEC 1000-4-2, 4kV CD, 8kV AD

Radiated: IEC 1000-4-3, 3 V/m

EFT/Burst: 1000-4-4, 1.0 kV

(power line), 0.5 kV (signal line)

## HP AdvanceStack 100VG Hubs

### Typical Uses

- Ideal for networks running applications that include real-time transactions, or multimedia requiring guaranteed, low and fixed latency response.

HP AdvanceStack 100VG Hubs deliver 10 times the speed of 10Base-T and up to 20 times the throughput for less than twice the price. These hubs are ideal for new, demanding, or time-sensitive applications such as multimedia, imaging, and video.

**Options:** Choose from three models:

- **Hub-7E:** This economical, Value Line 7-port hub is the cost-effective solution for small standalone workgroups in Ethernet environments.
- **Hub-14:** Expandable, manageable; offers 14 100VG ports (12 RJ-45 and 2 transceiver-based) and an expansion slot for the optional 100VG SNMP/Bridge Module. The Hub-14 is used to connect end nodes in a workgroup.

100VG Hub-7E



100VG Hub-14



### Ordering Information

HP J2415A AdvanceStack 100VG Hub-14  
HP J3137A AdvanceStack 100VG Hub-7E  
HP J2414B AdvanceStack 100VG SNMP/Bridge Module  
HP J2962A AdvanceStack Redundant Power Supply  
HP J3027A AdvanceStack 100VG Fiber-Optic Transceiver Module  
HP J3028A AdvanceStack 100VG UTP Transceiver Module

- **Advanced Features:** The optional HP J2414B AdvanceStack 100VG SNMP/Bridge Module for the Hub-14 includes HP AdvanceStack Assistant (ASA) software at no extra cost. (The Hub-7E is unmanaged.) This combination provides:
  - **Advanced management** capability supports SNMP/IP and IPX network management and monitoring on ASA or HP OpenView network management products. Also manageable via remote access or any management station with standard SNMP MIB browser functionality.
  - **Bi-directional bridging** capability between 10Base-T and 100VG networks via an optional, recessed transceiver (UTP or fiber).
  - **Workgroup security**, including network management alarms, authorized managers list, and password protection.
  - **Advanced troubleshooting** with design for intelligent network traffic monitoring, performance optimization, and trend analysis using HP EASE.

## 100VG Hub Features

One expansion slot	A slot for adding management; another for adding switching or routing. One module provides functionality for the whole stack.
2 transceiver slots to enhance media flexibility (Hub 14 only)	Provides fiber-optic or UTP connectivity via optional transceivers (must be purchased separately).
High performance	Powerful 100Mbps solution supports applications needing a high-speed, low-latency, deterministic network.
IEEE compliance	Provides flexible, software-configurable Ethernet and Token Ring frame support over existing cabling.
Redundant power supply	The optional HP J2962A RPS allows connection of up to four devices for maximum uptime.
Warranty	Backed by lifetime (for as long as you own the product) warranty and next-business day advanced replacement, where available.

## Competitive Strengths

- IEEE compliance provides flexible, configurable support and 100Mbps technology over existing category 3 cable.
- Delivers 100Mbps performance on existing 10Base-T topologies (category 3 or better cabling), with up to 96% bandwidth utilization.
- Provides collision-free operation and (with the SNMP/Bridge module) enables traffic prioritization.
- Backed by lifetime (for as long as you own the product) warranty and next-business day advanced replacement, where available.

## Frequently Asked Questions

*Can you connect 100VG-AnyLAN to an existing 10Mbps Ethernet network?*

**Yes**, you can connect a 100VG-AnyLAN network to an existing Ethernet network using a simple bridge. A router may be used to connect to token ring, FDDI, and ATM backbones, and Wide Area Networks (WANs).

*Is 100VG-AnyLAN compatible with existing Network Operating Systems (NOS) and applications?*

**Yes**, 100VG-AnyLAN supports Ethernet/IEEE 802.3 and IEEE 802.5 frame format and Medium Access Control (MAC) service interface to the Logical Link Control (LLC). All you need is the appropriate driver for your 100VG-AnyLAN network adapter card. LAN adapter (NIC) drivers are available from HP's Reseller Plaza website.

*How many HP 100VG hubs can I cascade together?*

**Up to five levels** of cascading is supported. In fact, HP 100VG supports the same topology rules as a 10Base-T network, and more.

For more 100VG FAQs, see the Reseller Plaza website.

**For More** on using 100VG hubs in a network, go to the HP Reseller Plaza website.

Select Technology/white papers/100VG AnyLAN to access information on upgrading to 100VG, 100VG technology, several 100VG white papers, and more 100VG FAQs.

### SPECIFICATIONS

#### ENVIRONMENTAL

Operating Temperature:  
0° to 55° C (32° to 131° F)  
Operating Relative Humidity:  
15 to 95% @ 40° C (104° F),  
noncondensing

#### PHYSICAL

Dimensions:

Hub-7E: 21.6 x 19.0 x 4.5 cm  
(8.5 x 7.5 x 1.75 in)

#### STANDARDS

#### COMMUNICATIONS

IEEE 802.12 Type 100VG

With SNMP Module:

RFC 1213; MIB II, RFC1493: Bridge  
MIB (Hub-14 only)

With SNMP and transceiver  
modules: IEEE 802.3 Type 10Base-T  
(Hub-14 only)

#### SAFETY

EN 60950/IEC 950; UL 1950; CSA 950  
NOM-019-SCFI-1994  
NOM-001-SCFI-1993

#### EMISSIONS

EN 55022/CISPR-22 Class A  
FCC Class A  
VCCI Level 1

#### IMMUNITY

Generic: EN 50082-1  
ESD: IEC 801-2 4kV CD, 8 kV AD  
Radiated: IEC 801-3 3 V/m  
EFT/Burst: IEC 801-4 1.0 kV  
(power line), 0.5 kV (signal line)



<http://www.hp.com/key/netreseller>

## HP AdvanceStack Switching Hubs

The HP AdvanceStack family of Switching Hubs provide a cost-effective way of connecting your PCs and servers to your LAN. These stackable hubs are ideal for any size network and scale to large or expanding high-performance workgroups, offering up to four fully-managed segments per hub, and the highest level of flexibility through easy insertion of additional functionality as needed. Management, monitoring (EASE and all nine groups of RMON), analysis, troubleshooting, switching, and routing are all available, enabling these hubs to dramatically improve network performance by optimizing the network *without* having to do in-depth studies on high-traffic areas.

**Options:** Choose from models having either 12 or 24 RJ-45 ports, or two 12-port Telco connectors.

Switching Hub-12R



Switching Hub-24R



Switching Hub-24T



- **Media Flexibility:** All models offer one 10Mbps transceiver bay on the front panel for an optional fiber-optic, ThinLAN, AUI, or UTP transceiver.
- **Management Module:** Install this optional module in the management slot of a switching hub to fully manage all four LAN segments within the stack backbone (up to 8 hubs per stack; up to 32 isolated segments per stack).
- **Switch Module:** Install this optional module in the expansion slot of a switching hub in a stack to connect all segments in the stack together. The four external switch ports (three RJ-45 ports; one transceiver bay) on the module itself allow dedicated Ethernet segments for uses such as connections to servers, other workgroups, and backbones. The transceiver bay accepts an optional 10Mbps fiber-optic, ThinLAN, AUI, or UTP transceiver.
- **Router Module:** Install this optional module in the expansion slot on a switching hub in a stack to enable Cisco-compatible Internet connectivity or branch-office WAN routing. See “HP AdvanceStack Internet Router” on page 5-40.



## Switching Hub Features

Two Expansion Slots	A slot for adding management; another for adding switching or routing. One module provides functionality for the whole stack.
Flexible Hub Architecture	Allows partitioning of stacked hubs into four fully managed LAN segments with up to eight hubs per stack (up to 32 isolated segments per stack)
Port Switching	Allows any port on the hub to be placed on any segment in the stack; allows segments as small as one port
Optional Management Pack (HP J3210A)	<b>Management module</b> fully manages all four LAN segments in all hubs in the stack. Increases bandwidth and:
<ul style="list-style-type: none"> <li>• Management Module</li> <li>• HP ASA</li> </ul>	<ul style="list-style-type: none"> <li>• Adds port-switching capability for software-based port changes without going to the wiring closet.</li> <li>• Configures any port as a primary or backup link between devices; backup link is automatically activated in the event of a critical link failure.</li> <li>• Includes Intel i960 RISC-based processor, 1 Mbyte RAM, and 1Mbyte flash EEPROM.</li> <li>• Includes intruder prevention, auto port disabling, network management alarm, eavesdrop prevention, authorized managers list, and password protection.</li> <li>• Allows autopartitioning for fault isolation.</li> <li>• Includes console interface option. Allows management, configuring, and troubleshooting through telnet, modem, or direct connect.</li> </ul> <p><b>HP AdvanceStack Assistant</b> management software provides traffic monitoring (EASE and RMON), real-time troubleshooting, and recommendations for improved performance. (See "Network Management" on page 5-2.)</p> <ul style="list-style-type: none"> <li>• Load-balancing feature in ASA automatically redistributes traffic for fine tuning performance.</li> <li>• Port switching lets you place any port on the hub onto any segment using drag-and-drop; a segment can be as small as one port.</li> </ul>
Optional Switch Module	Offers full internal switching capabilities, such as: <ul style="list-style-type: none"> <li>• Automatic load balancing to intelligently segment ports based on traffic levels.</li> <li>• Automatic configuration of ports across multiple segments.</li> </ul>
Optional Redundant Power Supply (RPS)	The HP J2962A RPS allows connection of up to four devices for maximum uptime.
Rack Mounting	Mounts in standard 19-inch rack, on a wall, or on any horizontal surface, such as a shelf or table; mounting hardware included.
Interoperability	Standards-based design enables efficient inter operation with equipment from Cisco, 3Com, and Bay Networks.
Warranty	Backed by lifetime (for as long as you own the product) warranty and next-business day advanced replacement, where available.

### Typical Uses

- Ideal for existing shared 10Mbps environments that are growing and have an expected need for additional bandwidth.
- Also ideal for networks adding new hubs/users that can benefit from segmentation but do not need dedicated 10Mbps to every desktop.



**For More** on using switching hubs in a network, go to the Technology page on the HP Reseller Plaza website.



<http://www.hp.com/key/netreseller>

#### Ordering Information

##### Switching Hubs:

HP J3200A AdvanceStack 10Base-T Switching Hub-12R (12 RJ-45 ports)  
HP J3202A AdvanceStack 10Base-T Switching Hub-24R (24 RJ-45 ports)  
HP J3204A AdvanceStack 10Base-T Switching Hub-24T (two 12-port Telco connectors)

##### Switching Hubs with Mgmt. Bundle:

HP J3201A Bundle (J3200A Hub-12R with J3210A Management Pack)  
HP J3203A Bundle (J3202A Hub-24R with J3210A Management Pack)  
HP J3205A Bundle (J3204A Hub-24T with J3210A Management Pack)

(For memory recommendations, see "RMON" on page 5-25.)

##### Accessories

##### Modules:

HP J3210A AdvanceStack 10BT Management Pack  
HP J3212A AdvanceStack 10BT Hub Switch Module  
HP J3138A AdvanceStack Internet Router  
HP J2962A AdvanceStack Redundant Power Supply

##### Transceivers:

HP J2606A AdvanceStack FOIRL Fiber-Optic Transceiver  
HP J2607A AdvanceStack 10Base-T Twisted-Pair Transceiver  
HP J2608A AdvanceStack 10Base2 ThinLAN Transceiver  
HP J2609A AdvanceStack AUI Port Module

## Competitive Strengths

- An HP AdvanceStack 10Base-T switching hub with a management module installed can provide not only segmentation, but also switching capabilities. Included is automatic port load balancing and automatic configuration for both an external switch and the optional, internal HP J3212A Switch Module. This gives users the flexibility to choose between an external or internal switch. These are features no other hub vendor provides.
- Customers get full management of the stack, including such features as automatic load balancing and configuration, by installing only one HP J3210A AdvanceStack 10Base-T Switching Hub Management Pack, thereby saving money and lowering complexity. (The pack includes the Management Module and the HP AdvanceStack Assistant software.)
- All nine groups of RMON are now available on all four segments of the HP AdvanceStack 10Base-T Switching Hubs simultaneously. This gives network administrators the tools to dig deeply into network issues with detailed troubleshooting and historical information. (For memory recommendations, see "RMON" on page 5-25.)
- Backed by lifetime (for as long as you own the product) warranty and next-business day advanced replacement, where available.

## Suggested Demonstration Features

**Network Management and Load Balancing:** Show how ASA monitors traffic and uses load balancing to easily and effectively reduce unnecessary bandwidth usage. *To prepare for and run this demonstration, see "Setting Up and Running a Load-Balancing Demonstration" in the Reseller Plaza area of the HP Network City website, below.*

## More Competitive/Product Information

- **Competitive:** See the Reseller Plaza website.
- **Product:**
  - HP Networking Products Data Sheet (p/n 5966-2253EUC)
  - HP AdvanceStack Assistant Emulator CD-ROM (p/n 5965-5979E)
  - HP Reseller Plaza website (URL shown above)
  - Manuals on the Reseller Plaza website (URL shown above).

## Frequently Asked Questions

(For more FAQs on Switching Hub connectivity and other topics, see the Support section on HP's Network City website at [http://www.hp.com/go/network\\_city](http://www.hp.com/go/network_city).)

### *What is segmentation?*

Segmentation is the act of dividing the network into smaller parts or collision domains. Each segment will then have fewer users on it. Fewer users means less traffic which makes collisions less probable. A lower collision rate means improved performance.

HP 10Base-T Switching Hubs have four segments to which you can move ports by using the ASCII console or HP AdvanceStack Assistant. If the network becomes congested and network performance suffers, use the Management Pack (J3210A) to move ports onto other segments in the stack (port switching). An HP Switch Module (J3212A) in the stack can add value by providing communication between segments. Another feature of the Switch Module is its ability to automatically distribute users across all segments upon power up. You can also use external devices such as, routers, bridges or switches instead of a Switch Module to provide communication between the segments.

### *How do the 10Base-T Switching Hubs differ from the other HP 10Base-T hubs?*

A Management Module installed into at least one of the 10Base-T Switching Hubs in the stack allows you to access the four network segments, as if there were actually four hubs in one. These four segments can be distributed across all of the hubs in the stack. The interconnection of hubs in a stack is accomplished using the provided Stacking Cables.

### *What is port switching, and why would I want to use it?*

Port Switching is the ability to move ports from one segment to another through software rather than physically moving cables from one hub to another. If the network becomes congested and network performance suffers, the Management Module, coupled with HP AdvanceStack Assistant, can be used to move ports onto other segments in the stack. Also, if you have an HP Switch Module in the stack, it can automatically distribute users across all segments at power up.

### *What is load balancing?*

Load balancing examines your network and automatically redistributes the ports to balance the network load. You can select the load balancing option using the ASCII console or AdvanceStack Assistant. This simple, one button approach to balancing network traffic is an ideal way for network administrators to optimize networks without having to do in-depth studies on high traffic areas. To set up a load-balancing demonstration, see "Setting Up and Running a Load-Balancing Demonstration" in the Reseller Plaza area on HP's Network City website. (See page 5-38.)

## SPECIFICATIONS

### ENVIRONMENTAL

Operating Temperature:  
0° to 55° C (32° to 131° F)  
Operating Relative Humidity:  
15 to 95% @ 40° C (104° F),  
noncondensing

### PHYSICAL

Dimensions: 44.2 x 31.8 x 6.6 cm  
(17.4 x 12.5 x 2.6 in)

Weight: 4.1 kg (9.0 lb)

### ELECTRICAL

AC voltage: 100-127/200-240 volts  
Current: 1.0A max at 100-127 volts  
0.6A max at 200-240 volts  
Frequency: 50/60 Hz

## STANDARDS

### COMMUNICATIONS

IEEE 802.1  
IEEE 802.3 Type 10Base-T  
IEEE 802.3 Type FOIRL  
IEEE 802.3 Type 10Base-2  
RFC 1368 IEEE repeater MIB  
and MIB II

### SAFETY

EN 60950/IEC 950; UL 1950; CSA 950  
NOM-019-SCFI-1994

### EMISSIONS

With shielded cables:  
EN 55022/CISPR-22 Class B  
FCC Class B  
VCCI Level 2

With unshielded cables:  
EN 55022/CISPR-22 Class A  
FCC Class A  
CCI Level 1

### IMMUNITY

Generic: EN 50082-1  
ESD: IEC 801-2 4kV CD, 8 kV AD  
Radiated: IEC 801-3 3 V/m  
EFT/Burst: IEC 801-4 1.0 kV  
(power line), 0.5 kV (signal line)

# HP AdvanceStack Internet Router

## Typical Uses

- **As a modular solution**, the HP AdvanceStack Internet Router inserts into the expansion slot of HP AdvanceStack 10Base-T Switching Hub-12, Hub-24R, and Hub-24T.
- **As a standalone solution**, the HP AdvanceStack Remote 2C and Internet Router bundle provides an expandable (2-slot) solution for use in any network environment.

## Ordering Information

HP J3138A AdvanceStack Internet Router  
 HP J3231A AdvanceStack Remote 2C and AdvanceStack Internet Router Bundle (Remote 2C with J3138A)  
 HP J3139A V.35 Synch Cable  
 HP J3140A RS-323 Synch Cable

The HP AdvanceStack Internet Router Module (with Cisco IOS software) is an integrated branch office solution providing economical, highly reliable, and scalable Internet/WAN connectivity with secure firewall protection.

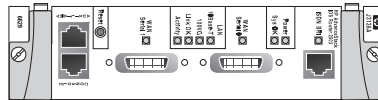

The slide-in module facilitates remote installation, configuration, and management of geographically distributed workgroups. Cisco IOS software, desktop version, provides protocol and routing support for all major internetworking protocol suites, including TCP/IP, IPX, and AppleTalk.

- Includes Cisco IOS software (desktop version).
- Installs in several HP hub and switch models and in the two-slot Remote 2C expansion cabinet, enabling operation in a mixed vendor network and allowing connectivity to a wide variety of HP products.
- Supports configuration/management via HP OpenView with Cisco-Vision

Performance features	PPP compression Bandwidth-on-demand Load balancing for bandwidth up to 512Kbps Dial-on-demand routing (DDR) IPX spooling for maximum WAN bandwidth optimization ISDN compression for performance (with 4:1 compression) of up to 512Kbps
Support for redundant power supply option	All module-compatible AdvanceStack devices support a redundant power supply (RPS) option for 100% uptime.
Availability, flexibility, and optimum port configuration	The module is equipped with flash RAM (8MB SIMM expandable to 16MB; 8MB DRAM expandable to 32MB) and a WAN backup line to ensure availability of critical LAN resources. Port features include: <ul style="list-style-type: none"> <li>• Two high-speed, synchronous WAN ports to provide resilient WAN links with either another high-speed serial link or a cost-effective ISDN connection.</li> <li>• One RJ-45 ISDN BRI without NT-1</li> <li>• One RJ-45 auxiliary port</li> <li>• One console port</li> </ul>
Ease-of-use	Console port (cable included) enables local terminal, while SNMP supports remote management; autoinstall reduces the complexity of configuration
Security	Full security for access lists; MDS routing authentication; network layer encryption; supports Radius and TACACS+

---

## Competitive Strengths

- Combined solution of best-in-class products: HP AdvanceStack 10Base-T Switching Hubs and the Cisco IOS-based router.
- Because the router is Cisco IOS-based, it is seamlessly compatible with Cisco central site routing solutions.
- With HP as the solution provider, you and your customers need only contact one vendor for support and warranty issues.
- Backed by lifetime (for as long as you own the product) warranty and next-business day advanced replacement, where available.

For Frequently Asked Questions, go to the HP Network City website at:

[http://www.hp.com/go/network\\_city](http://www.hp.com/go/network_city)

and click on Support/Internet Router/  
Frequently Asked Questions

---

## More Competitive and Product Information

- **Competitive:** See the *Reseller Plaza* website at <http://www.hp.com/key/netreseller>
- **Product:** For easy access to application notes and white papers available on the world wide web, go to HP's Network City website (URL shown above) and click on the following sequence of titles:
  - Products
  - Internet/Remote Office
  - Internet Access
  - Related Topics

You can then select from the following articles:

- Guide to Configuring HP and Cisco Routers to Operate Together
- Fundamentals of Internetworking
- Leased Line HDLC Connections Between IOS Routers
- Leased Line PPP Connections Between IOS Routers
- Leased Line PPP Connections Between IOS and HP Routers
- Frame Relay Connections Between IOS and HP Routers  
*Where the central site router is an HP using IP multi-net addressing*
- Frame Relay Connections Between IOS and HP Routers  
*Where the central site router is an HP using a single IP address for the frame relay network connected to IOS routers*
- Frame Relay Connections Between IOS and HP Routers  
*Where the central site router is a Cisco using sub-addressing*
- Frame Relay Connections Between IOS Routers  
*This network is connected with frame relay in a fully meshed configuration*
- Frame Relay Connections Between IOS Routers  
*This network is connected with frame relay in a partial meshed configuration using subaddressing*

### SPECIFICATIONS

#### ENVIRONMENTAL

Operating Temperature  
0° to 55° C (32° to 131° F)  
Operating Relative Humidity:  
15 to 95% @ 40° C (104° F),  
noncondensing

#### PHYSICAL

Dimensions:  
16.6 x 6.8 x 4.1 cm  
(6.6 x 6.8 x 1.6 in)

Weight: 0.91 kg (2 lb)

#### ELECTRICAL CHARACTERISTICS

Supplied from expansion slot

### STANDARDS

#### SAFETY

EN 60950/IEC 950; UL 1950; CSA 950

#### EMISSIONS

EN 55022/CISPR-22 Class A  
FCC Class A; VCCI Level 1

#### IMMUNITY

Generic: EN 50082-1  
ESD: IEC 801-2 4kV CD, 8 kV AD  
Radiated: IEC 801-3 3 V/m  
EFT/Burst: IEC 801-4 1.0 kV  
(power line), 0.5 kV (signal line)

## HP 10/100VG LAN Adapter Cards (NICs)

**Driver support** is available for all major network operating systems, including:

Novell® NetWare®  
Microsoft Windows NT  
Microsoft Windows 95  
Microsoft Windows 98  
Microsoft Windows for Workgroups  
Microsoft LAN Manager  
SCO® UNIX  
IBM® sOS/2 Warp

HP 10/100VG LAN Adapter Cards are the best way to optimize your HP business computing environment. They provide an easy, affordable migration path from 10Base-T to high-speed networking, with connectivity to both 10Mbps and 100Mbps. HP 10/100VG LAN Adapter Cards are available in both PCI- and ISA-compatible versions.

HP J2585B 10/100VG PCI Adapter



HP J2573A 10/100VG ISA Adapter



## Competitive Strengths

**Technology:** 100VG technology is the best choice for time-sensitive applications such as multimedia.

### Manageability:

- Simple to install with plug-and-play support, full software configuration and diagnostics, plus LEDs.
- Easy to troubleshoot, with DMI and SNMP network management support.
- Broad driver support for all major network operating systems.

### Availability:

- HP quality assures high reliability and uptime, backed by HP's industry-leading warranty.
- Industry-leading service and support, including online answers to technical questions, comprehensive documentation, and information on new product releases.
- If your HP 10/100 NIC is installed in an HP PC or HP NetServer that has an on-site warranty, then the NIC will inherit that on-site warranty.

### Performance:

Choice of 10Mbps or 100Mbps technology for high-speed networking and demanding applications such as multimedia.

- Multiple modes of operation, including bus mastering, for optimum performance and low CPU utilization.

---

## More Competitive/Price Information

- Competitive: See the Reseller Plaza website.



<http://www.hp.com/key/netreseller>

---

## Frequently Asked Questions

### *Why buy HP 10/100VG LAN Adapter Cards?*

With their unbeatable warranty, free customer support, high-speed performance, broad compatibility, reassuring reliability, and value pricing, HP 10/100VG LAN Adapter Cards are the network connection for HP computers.

### *When does it make sense to use 100VG-AnyLAN over Fast Ethernet?*

Use 100VG AnyLAN for demanding applications such as multimedia, imaging, and video. Because of 100VG-AnyLAN's Demand Priority Protocol (DPP), video images are always smooth and never interrupted. Use Fast Ethernet when you combine Fast Ethernet with switching.

### *How is 100VG different from Ethernet/Fast Ethernet?*

Like Fast Ethernet, 100VG-AnyLAN (IEEE 802.12) also provides 100Mbps. The architecture differs from Fast Ethernet/Ethernet's collision domain in that 100VG-AnyLAN uses a round-robin arbitration method to determine which nodes want to send data. This method is perfect for multimedia applications because multimedia data is designated as high priority and are transmitted before normal priority data is transmitted. 100VG-AnyLAN is easily implemented in sites that have only 4-pair Category 3 wiring, because only 100VG operates over this cable. (Fast Ethernet requires a site to convert all Category 3 cable to Category 5.) Both 100VG-AnyLAN and Fast Ethernet work over twisted-pair and fiber-optic cabling.

### *Will HP continue to market 100VG products?*

**Yes.** HP is continuing to offer 100VG as a solution for providing 100Mbps connections to the desktop. HP's 100VG technology continues to offer a cost-effective, high-performance, reliable, customer-tested, standards-based alternative to 100Base-T.

### *Will HP continue to develop 100VG products?*

**Yes.** The most recent product commitments include projects to develop driver upgrades for VG NICs. HP is committed to staying current with upgrades to NT, Windows, and NetWare.

### Ordering Information

#### PCI

HP J2585B 10/100VG PCI LAN Adapter

#### ISA

HP J2573A 10/100VG ISA LAN Adapter

## Accessories Index

This table lists the modules, transceivers, and redundant power supplies available for HP switches and hubs.

Product Number	Product Name	Product Compatibility
J2414B	HP AdvanceStack SNMP/Bridge Module	100VG Hub-14
J2573A	10/100VG ISA LAN Adapter (single) (See also J3005A and J3006A.)	
J2585B	10/100VG PCI LAN Adapter (single) (See also J3009B and J3010B.)	Vectra PCs, HP NetServers
J2606A	AdvanceStack FOIRL Fiber-Optic Transceiver Module	Switch 2000 10Base-T Module, Hubs: 12R, 24R, 24T, 8U, 16U
J2607A	AdvanceStack 10Base-T Twisted-Pair Transceiver Module	Switch 2000 10Base-T Module, Hubs: 12R, 24R, 24T, 8U, 16U
J2608A	AdvanceStack 10Base-2 ThinLAN Transceiver Module	Switch 2000 10Base-T Module, Hubs: 12R, 24R, 24T, 8U, 16U
J2609A	AdvanceStack AUI Port Module	Switch 2000 10Base-T Module, Hubs: 12R, 24R, 24T, 8U, 16U
J2962A	AdvanceStack Redundant Power Supply	Switches: 800T, 208, 224, Hubs: 14, 16U, 12R, 24R, 24T
J3027A	AdvanceStack Switch 2000 100VG Fiber-Optic Transceiver	Switch 2000, Hub 14
J3028A	AdvanceStack Switch 2000 100VG UTP Transceiver	Switch 2000, Hub 14
J3102A	AdvanceStack Switch 2000 Ethernet Module	Switch 2000
J3103A	AdvanceStack Switch 2000 100VG Module	Switch 2000
J3108A	AdvanceStack Switch 2000 FDDI Module	Switch 2000
J3109A	AdvanceStack Switch 2000 10Base-FL Module	Switch 2000
J3133A	AdvanceStack 10Base-T Hub-8U/16U SNMP Module	Hub-8U, Hub-16U
J3136A	AdvanceStack Redundant Power Supply	Switch 2000
J3138A	AdvanceStack Internet Router	Switch 208, Switch 224, Hub-12R, Hub-24R, Hub-24T
J3139A	V.35 Synchronous Cable	Internet Router Module
J3140A	RS-232 Synchronous Cable	Internet Router Module
J3178A	AdvanceStack Switch 208/224 Management Module	Switch 208T, Switch 224T
J3191A	AdvanceStack Switch 2000 100Base-T Module	Switch 2000
J3192C	AdvanceStack 100Base-TX Twisted Pair Transceiver Module	Switch 2000, Switch 800T, Switch 208, Switch 224
J3193B	AdvanceStack 100Base-FX Fiber-Optic Transceiver Module (SC connectors)	Switch 2000, Switch 800T, Switch 208, Switch 224
J3210A	AdvanceStack 10BT Management Pack	Hub-12R, Hub-24R, Hub-24T
J3212A	AdvanceStack 10BT Hub Switch Module	Hub-12R, Hub-24R, Hub-24T
J3246A	AdvanceStack Switch 2000 ATM Module	Switch 2000
J3247A	HP AdvanceStack 10/100Base-TX Switch Port Module	Hubs: 12TX, 12TXM
J3248A	HP AdvanceStack 100Base-FX Switch Port Module	Hub-12TX, Hub-12TXM



# Chapter 6: Switching Technology



<http://www.hp.com/key/netreseller>

Switches are designed to ease traffic caused by excessive contention over shared media. Switches segment shared Ethernet networks. Each segment carries as much traffic as the original network, allowing you to greatly increase the performance of a network without having to replace the existing infrastructure. By combining fast transmission speeds and frame-switching technology, switches create multiple data paths in parallel—supporting simultaneous conversations.

For further information on switching, please visit the HP Network Reseller Plaza website.

## Evolution from Shared Ethernet to Switched Ethernet

Most networks are shared Ethernet networks. As the demand for higher bandwidth continues to grow, Ethernet limitations begin to affect network performance. In a single segment Ethernet network, only one user can access the network at a time.

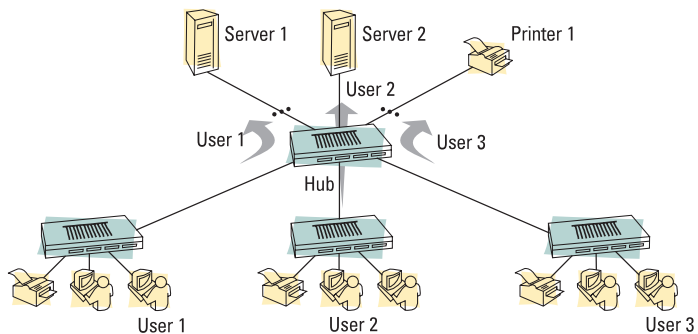

In this single segment Ethernet network, when User 1 uploads a file to Server 1, no one else can use the network. Users 2 and 3 must wait their turn to access the servers and printers on the network. Assuming this is a 10Base-T network, the maximum aggregate theoretical throughput is 10Mbps.

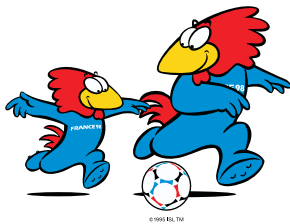

A typical shared, hub-based Ethernet network is a single collision domain or single segment. Every node on the segment hears all the traffic on the entire network, including broadcast messages produced by network-based applications. Adding more users and more network-based applications to the network can increase network usage, resulting in higher contention and more network collisions. Excessive collisions are often the cause of poor network performance.



Switches segment the network into multiple collision domains. For example, when a 10Base-T network is segmented into multiple collision domains, each workstation, server, or workgroup can transmit over a 10Mbps segment. Multiple collision domains can often relieve network congestion by reducing the amount of network traffic on any one segment, resulting in fewer collisions.

A network switch also allows multiple users to use the network at the same time. Switching can be compared to the operation of a telephone switch. All users connected to a switch can communicate with each other. Multiple communication sessions can also exist simultaneously. By replacing the hub with a switch in the Ethernet network, Users 1, 2, and 3 access the network at the same time. Note that no changes to the cabling infrastructure, network interface cards (NICs), or peripherals are required.

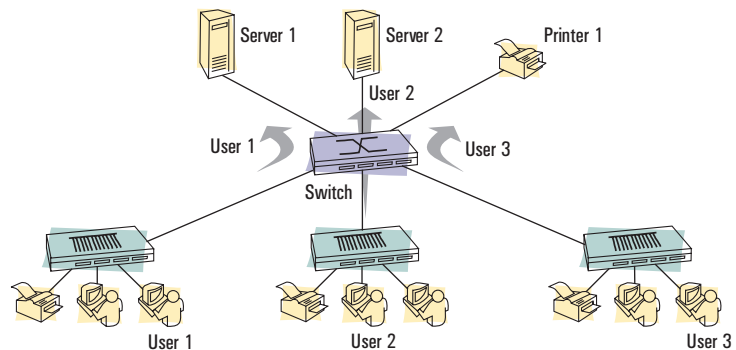

The combination of fewer collisions and simultaneous conversations can bring the theoretical total aggregate throughput of this network to 30Mbps (three users using the 10Mbps network at the same time)—a three-fold increase.

## Switch Operation

Switches operate at OSI layer 2 (Data Link Layer), and handle frames based on the MAC layer information in a frame. Switches that operate only at the Data Link layer are sometimes referred to as layer 2 switches. Some switches, like the HP AdvanceStack Switch 2000 and HP AdvanceStack Switch 800T, can also interpret information from OSI layer 3 (Network Layer). Though still forwarding packets based on the MAC information, it uses information from the network layer to limit the amount of broadcasts and selectively forwards other broadcasts only to the necessary ports. These switches are sometimes referred to as Layer 3 Switches.

## Layer 2 Switches

A layer 2 switch acts like a fast, multiport Ethernet bridge. A switch is designed to increase the performance of a LAN by adding multiple collision domains. With a switch, collisions can be confined to a single segment. Unlike most bridges, however, switches do not add significant delays to your network. Since network processing on a switch occurs in the hardware (compared to a bridge, where network processing often occurs in the software), latency is minimal. For example, a bridge may add 800 microseconds of delay to your network, compared to under 10 microseconds for a switch.

Layer 2 switches operate at OSI layer 2 only.

As network-based applications are added to a network, their corresponding network protocols add broadcast traffic to the network. This can result in broadcast storms. Broadcasts are processed by all nodes.

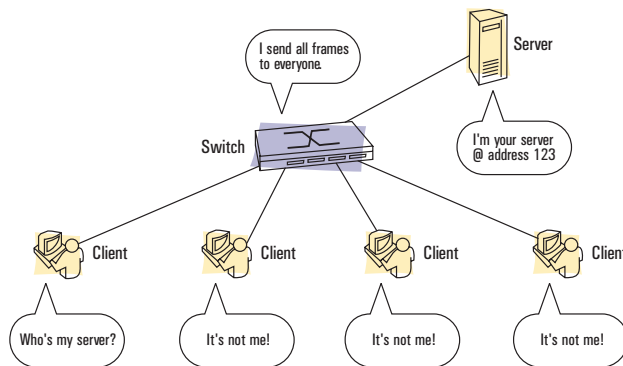

Broadcasts are processed by all nodes.

Like a hub, layer 2 switches propagate layer 3 broadcast and multicast packets out to all of the ports, causing all nodes to receive and process the packets. A layer 2 switch forwards messages back and forth between end nodes. *How does a client initiate communication with the server in a layer-2 switched IP network or subnetwork?*

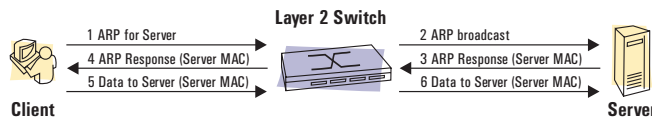

1. Prior to communication, each node on a network broadcasts an IP ARP. The ARP is part of the IP connection setup. When a client wants to connect to a server, the client sends an ARP broadcast for the server.
2. The layer 2 switch forwards the ARP to all ports of the switch, except for the port sending the packet.
3. The server responds with an ARP response. Included in the ARP response is the server's MAC address.

4. The switch forwards the ARP response to the client.
5. The client then sends data straight through to the server, without any packet modification. The switch does not modify the packet.
6. Data transfers can occur at high-performance wire speed.

Note that in a layer 2 switch, ARPs between two nodes are propagated throughout the entire network.

## Local Routing

With an increase in broadcast packets and the decrease in network performance, many network managers have added local routing to the network. Routers are used to segment the network into more manageable broadcast domains, and reducing broadcast traffic in the workgroups. Routers operate at OSI layer 3 (Network Layer). They handle packets based on the network addresses (such as the IP or the IPX address) rather than the MAC address. Each segment in a routed network is a separate *broadcast* domain. Only the router and any other nodes on the originating segment hear broadcast packets. The advantage of a router is that broadcast traffic is terminated at the router port. Nodes on other networks are not bothered by unnecessary broadcast traffic.

In a locally routed network, broadcast packets are terminated at a router port.

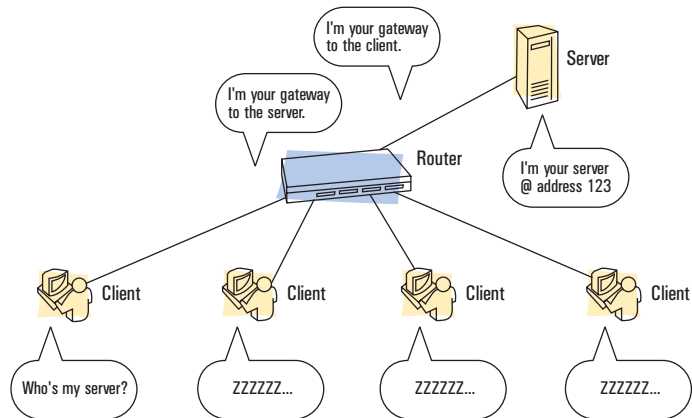

Routers require highly skilled technical people to install, configure and support.

Routers, however, are not without their disadvantages. Routers are complex, expensive, and slow compared to bridges or network switches. Routers typically require highly skilled technical people to configure and manage them. Routers also add significant latency delays to a network since each packet must be processed by the router.

*How does a client initiate communication with the server in a routed IP network or subnetwork?*

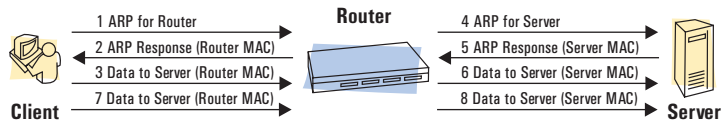

1. Prior to data transfer and if a node does not know the layer 2 MAC address of the router, each node on a network (in its normal operation) performs an IP ARP. The ARP is part of the IP connection setup. The client is configured to use the router as its default gateway. The client knows both the router and the server's IP addresses, but does not know the MAC address of either of them. The client needs to know the router's MAC address, so the client ARPs for the router's MAC address.
2. The router responds to the client with its MAC address.
3. The client sends its packet to the router's MAC address.
4. Before sending the packet to the server, the router must learn the server's MAC address. To do this, the router sends an ARP request to the server (assuming no ARP cache on the router).
5. The server responds to the router with its MAC address.
6. Before the router sends the packet to the server, it must first replace the MAC address in the packet with the server's MAC address—this ensures that the source MAC address is the MAC address of the router, and the destination MAC address is the MAC address of the server.

In this type of transmission, the router receives all packets on the network. If a packet needs to go from one side of the router to the other, the router modifies the packet by making sure the source MAC address is the router MAC address and the destination MAC address is the server address. Once it has made these changes, it retransmits the packet onto the network.

Delay times may be longer in a routed network.

## HP Layer 3 Switching

Layer 3 switches are a new class of LAN devices that combines the benefits of switching with the broadcast control of a router.

Layer 3 switching: benefits of a switch with the broadcast control of a router

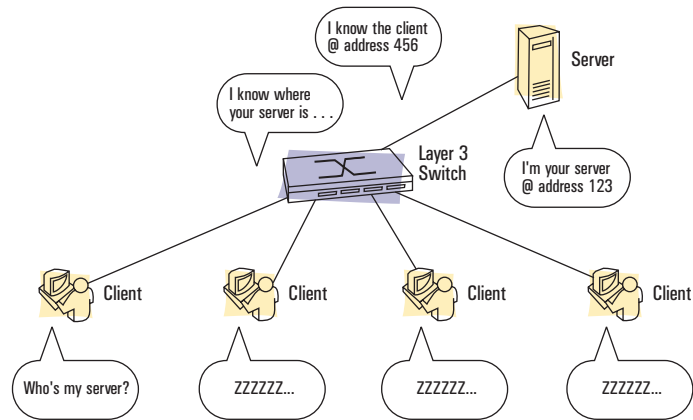

Like a router, layer 3 switches segment the network into broadcast domains. A layer 3 switch understands the operation of network-layer protocols, such as IP, in order to set up direct MAC-layer connections. The layer 3 switch provides:

- broadcast control
- separate collision domains for each segment
- reduced complexity of management
- very high throughput compared to local routing
- a cost-effective solution (especially compared to a locally routed network)

*How does a client initiate communication with the server in a layer-3 switched IP network or subnetwork?*

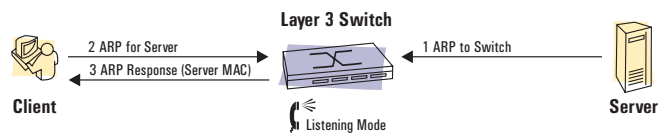

A layer 3 switch "learns" about the location of devices on a network.

1. When the layer 3 switch is turned on, it is in the listening/learning mode. Prior to data transfer and if a node does not know the layer 2 MAC address, each node on a network (in its normal operation) broadcasts an IP ARP. The ARP is part of the IP connection setup. The layer 3 switch eavesdrops on this address resolution phase. The switch acts as a passive device, listening and learning. As devices on the network (clients, servers, etc.) send and respond to ARP requests, the switch learns about locations of these devices. Similar to a router, tables are created (ARP cache table for IP, SAP and RIP tables for IPX) and an entry is made in the appropriate table.

2. When another node comes up and asks for a server, the switch intercepts the request, and provides the destination MAC address (IP) or the name (IPX) of the server (using the ARP cache or SAP and RIP tables). The originating node's broadcast does not get propagated onto other segments in the network, thus eliminating ARP and NSQ/RIP broadcasts.
3. The switch reads the source address of the node and packet forwarding occurs at media speed.

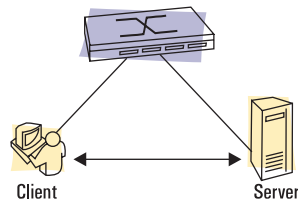

In a layer 3 switched network, broadcast packets are not propagated throughout the network.

The layer 3 switch acts similar to a router (learning and responding to ARPs) when communicating with network devices such as clients and servers during connection setup, and acts similar to a layer 2 switch during the flow-forwarding phase. By using its address table, the switch can resolve end-node addresses for any node in the network, even for nodes in remote subnets. Thus, ARPs between two nodes are not propagated throughout the network.

To further reduce broadcasts, the layer 3 switch intercepts IP RIPs and IPX RIPs and SAPs, and broadcasts them only out ports where routers or IPX servers have been automatically detected.

## Layer 2, Routing, and Layer 3 Switching Comparisons

	Layer 2 Switching	Routing	Layer 3 Switching
<b>Learning Mode</b>	<b>Passive</b> <ul style="list-style-type: none"> <li>Eavesdrops on normal network traffic</li> <li>Learns only MAC addresses</li> </ul>	<b>Active</b> <ul style="list-style-type: none"> <li>Explicit routing protocol between routing devices</li> </ul>	<b>Passive</b> <ul style="list-style-type: none"> <li>Eavesdrops on normal network traffic, as well as ARP, SAP, etc.</li> <li>Learns layer 3 addresses and IPX services</li> </ul>
<b>Initiation Path Setup</b>	<b>Direct to Target</b> <ul style="list-style-type: none"> <li>Tables in switch direct traffic straight to destination</li> </ul>	<b>Direct to Router</b> <ul style="list-style-type: none"> <li>Ensures traffic is sent to the router itself</li> <li>Receives and modifies packets</li> </ul>	<b>Direct to Target</b> <ul style="list-style-type: none"> <li>Tables in switch direct traffic straight to destination</li> </ul>
<b>Forwarding Data</b>	<b>Zero Hop Pass Through</b> <ul style="list-style-type: none"> <li>No Packet modification</li> </ul>	<b>Hop by Hop</b> <ul style="list-style-type: none"> <li>Packet received, modified and retransmitted</li> </ul>	<b>Zero Hop Pass Through</b> <ul style="list-style-type: none"> <li>No packet modification</li> </ul>

Generally, routers provide more security capabilities than switches. Use a router to control who can get to specific servers, etc. Routers are often used in the perimeter of a network, providing a gateway to WAN services.

## Network Switch Market Classes

Many vendors classify network switches in the following three market classes:

- Desktop/Workgroup Switch
- Departmental Switch
- Backbone /Campus/Interconnect Switch

## Desktop/Workgroup Switch

Use the desktop switch, also referred to as a workgroup switch, to significantly increase performance within a workgroup in a 10Base-T workgroup environment. Some desktop/workgroup switches are designed to replace 10Base-T hubs in a workgroup—typically, each device on the network is plugged into its own port on the switch.

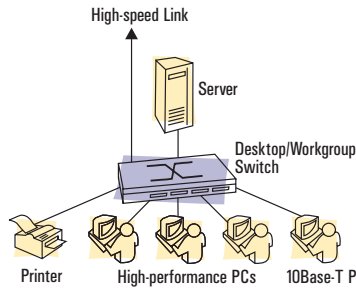

Desktop switches can replace hubs in a workgroup.

Desktop/workgroup switches are typically sold as fixed port boxes, with one or two high speed uplinks. Use the desktop/workgroup switch to significantly increase performance within a workgroup.

## Segment/Departmental Switch

Use departmental switches to interconnect workgroups.

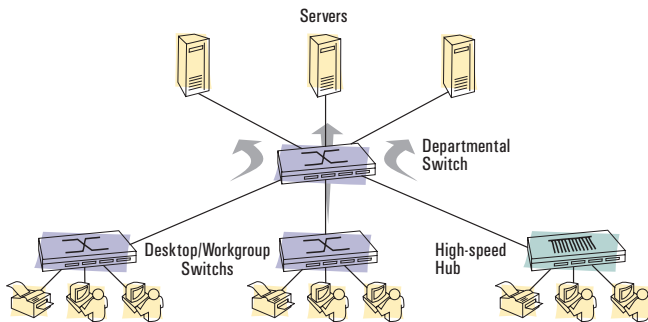

Departmental switches interconnect workgroups.

Desktop/workgroup switches and shared-media hubs are often connected to a departmental switch. Departmental switches support multiple, high-speed ports, such as 100BaseT, 100VG-AnyLAN, FDDI, Gigabit, or ATM. They usually have higher port density—commonly 12–64 Ethernet or fast Ethernet ports and 1–2 ATM or Gigabit ports. Departmental switches typically support Spanning Tree and layer 3 switching. User-defined packet filtering are often included. Departmental switches typically have larger address tables, flexible port configuration, and other high-end availability features such as redundant power supplies, swappable modules and fans.



## Backbone/Campus/Interconnect Switch

Backbone switches are intended to support large user populations and usually have higher port density.

Backbone switches connect multiple departmental switches.

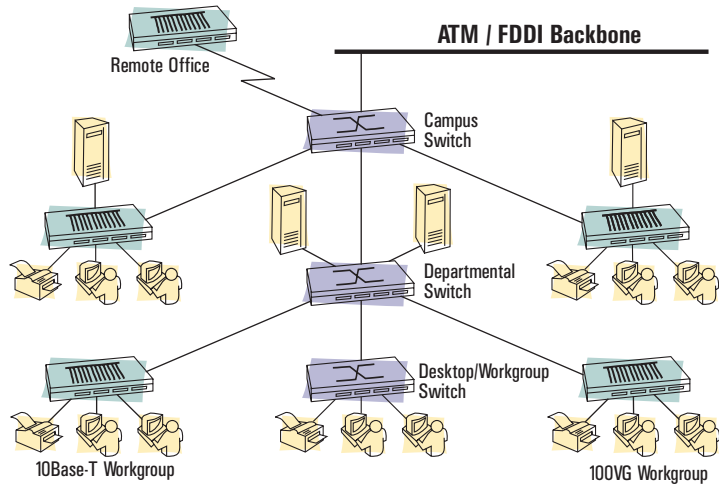

They support cell (ATM) and frame switching as well as some integrated routing services, robust management, and large feature set such as VLAN support, policy-based management and traffic analysis. The backbone switch is often installed as the “switch of switches”. It is usually modular, and provides connections to backbones such as ATM and FDDI. Often, they are used as a collapsed backbone to interconnect multiple LAN technologies, local workgroup segments, and shared server segments.

# Switch Architecture

When comparing switches from different vendors, it is important to evaluate switch architecture. Evaluate

- modes of operation
- architecture design
- switch fabric design

## Modes of Operation

Switches may change modes of operation, depending on the type of data, the condition of the network, and the feature set of the switch. Switches employ these major modes of operation:

- Store-and-Forward
- Cut-Through
- Runt-Free Cut-Through
- Early Cut-Through
- Adaptive Cut-Through

### Store-and-Forward

Store-and-forward switches completely buffer an incoming frame before forwarding it to another port.

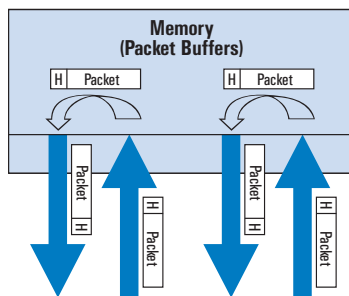

Store-and-forward: frames are buffered before forwarding.

Before forwarding a packet, the switch may perform other functions. These functions can range from simple error checking and address table construction, to layer 3 functionality like protocol and broadcast filtering. Store-and-forward switches are well suited for client-server environments because they don't propagate errors, support mixed media speeds, and can be modular in design.

The store-and-forward operation mode must be used when dissimilar media types are used (i.e., coax to fiber), or for speed matching (100Mbps to 10Mbps).

The fast-forward method of store-and-forwarding can significantly reduce latency by processing forwarding decisions while the packet is being stored. It delivers cut-through performance with store-and-forward reliability. The HP AdvanceStack Switch 2000, a fast-forwarding switch, has a LIFO switching latency of just 10 microseconds.

## Cut-Through

Standard cut-through switches initially examine only the frame's destination MAC address.

Cut-through: forwarding "on-the-fly".

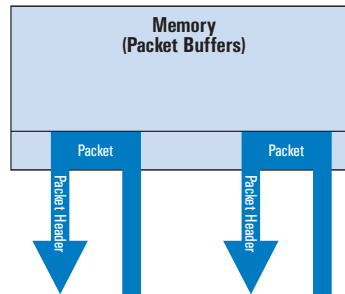

The source address is stored in a table before the decision is made to forward the frame to another port. Frames with unknown destination addresses are forwarded to all ports to find the correct destination address. Frames with known destination addresses are forwarded to the destination port as soon as the address is found in the table. This is sometimes referred to as "forwarding on the fly" and results in very low latency.

No error correction is done—bad frames, such as CRC errors, runs, and jabbers, are also forwarded.

A switch cannot operate in just cut-through mode as incoming packets have to be buffered in case the destination port is busy.

Cut-through is most effective with large, error-free peer-to-peer environments and cannot be implemented for segments with different speeds or dissimilar media types.

## Runt-Free Cut-Through

Runt frames (Ethernet frames less than 64 bytes) are discarded in runt-free, cut-through mode. The minimum length of an Ethernet frame is 64 bytes. If a collision occurs on the network, a "bad" frame (a frame with less than 64 bytes) is transmitted. This is called a runt frame. In runt-free, cut-through mode, the switch receives a frame and examines the first 64 bytes. If the frame contains 64 or more bytes, it will send it to its destination; if the frame is less than 64 bytes, it will discard the frame and update its runt-frame statistic.

## Early Cut-Through

When a switch is operating in early cut-through mode, it begins forwarding a received frame as soon as it reads the destination address. It does not look at the source address. Early cut-through mode typically yields the lowest latency and is used after address tables have been established.

## Adaptive Cut-Through

Adaptive cut-through mode provides some error-detection. During adaptive cut-through, the switch keeps track of the number of incoming frames with CRC errors. When a given error threshold is exceeded, the switch automatically changes its operational mode to store-and-forward. This isolates CRC errors to a single segment and prevents bad frames from being forwarded to another port. When the error rate is once again below the error threshold, the operational mode reverts back to cut-through.

---

## Architecture Design

Switches can be either processor-based or Application Specific Integrated Circuit (ASIC)-based. Processor-based switches are built with existing industry-standard processors. Switching functionality in a processor-based switch is performed in software. ASIC switches are a combination of hardware and firmware, with the ASIC custom-designed for switching. Switching functionality is performed within the ASIC.

ASIC-based switches are often preferred over processor-based switches because they are much faster.

---

## Switch Fabric Design

The switch fabric is the method used to actually route a packet from one port to another. Two typical methods are:

- Cross-Point Matrix
- Shared Bus (shared backplane)

## Cross-Point Matrix

In a cross-point matrix switch, all ports of the switch are internally connected to all other ports.

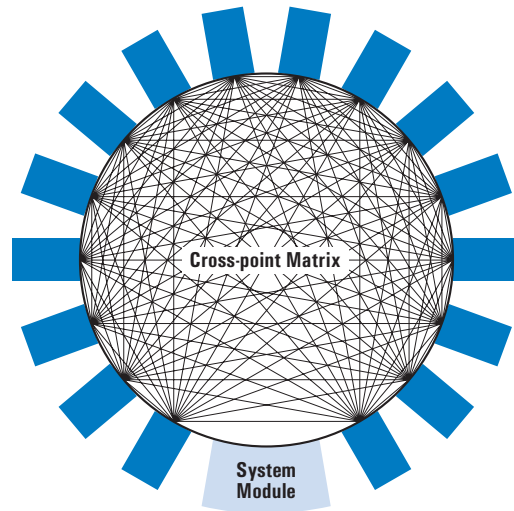

These arrays of switching elements provide parallel, switched paths between all possible pairs of input and output ports. Any port can be dynamically connected to any other port through a cross-point matrix. The system module learns the location of node addresses communicating through each port and creates a table for each port. After the tables are established, packets go straight to the correct port, and are not directed by the system module.

## Shared Bus

In a shared backplane (or sometimes called a shared bus) switch, an internal, high-speed backplane is used to interconnect switch ports.

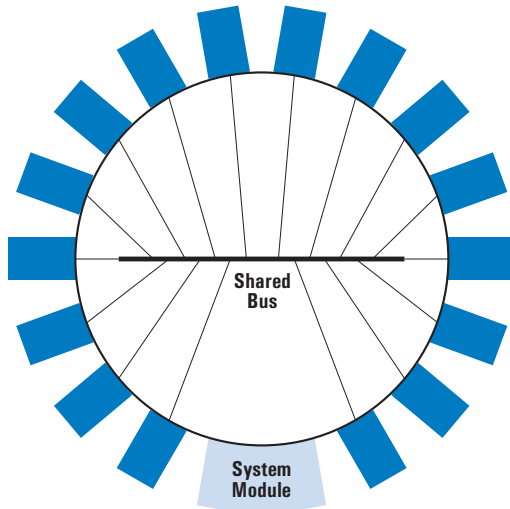

With a shared backplane, a switch shares its high-speed backplane with all ports connected to it. The backplane operates at such high speeds that it can handle full speed on all ports at the same time. High-speed backplanes can easily handle multiple, simultaneous conversations. Shared backplane architectures are frequently used to build module switches that can scale to high port densities and interconnect LAN technologies such as FDDI, 100BaseT, ATM, and 100VG.

---

## Memory Architecture

Switch memory (used for buffers, address tables, etc.) can be allocated in a number of different ways.

- **Pooled Shared Memory:** Allocates memory as needed from a common pool of memory shared by all ports within the switch.
- **Dedicated Shared Memory:** Allocates a fixed amount of memory from a common pool of memory to be shared by a single pair of I/O ports.
- **Distributed Memory:** Each port has its own dedicated, fixed-sized memory. The switch also has its central memory for shared operations such as global address tables.

Shared memory architectures provide good economies of scale for low-cost, small switches. They easily accommodate mixed LAN types and speeds within a single switch. Distributed memory architecture is scalable at the high end, and is usually more costly.

---

# Switch Performance Parameters

With the addition of a switch, your clients expect improved network performance. Several factors affect switch performance, and there are trade-offs to consider when recommending a switch to a client. How can you measure the actual performance of a switch, and how do you explain these measurements to your client? The performance measurements you will need to discuss include:

- Throughput
- Frame/Packet Loss Rate
- Latency
- Congestion control

---

## Throughput

Throughput: maximum rate a switch can forward packets.

Throughput is defined as the maximum rate at which a switch can forward packets without packet loss. Throughput is measured by the number of packets or frames per second. The theoretical maximum throughput of a switch is calculated by summing up all the possible packet streams (determined by the number of ports per switch), and taking into account different media types and their relative maximum bandwidth.

---

## Frame/Packet Loss Rate

Frame/packet loss rate: % of packets dropped.

Frame loss rate (or forwarding rate) is defined as the percentage of packets dropped by a switch under test conditions, while processing packets at media speed on all ports. Packet loss is generally due to buffers not being emptied as fast as they are being filled. Packet loss rate values vary due to the capacity of a switch.

---

## Latency

Switch latency is defined as the time it takes for a switch to process a data frame. Latency is calculated differently depending on the mode of operation.

### Store-and-Forward Latency

For switches that store, process, and then forward incoming frames, latency is measured as the elapsed time between receiving the last bit of the incoming frame and transmitting the first bit of the resulting outgoing frame. This is referred to as last-in, first-out (LIFO). Latency for store-and-forward devices is independent of packet size. Latency, however, may be increased by the feature set of a switch (filtering, policy-based management, etc.).

### Cut-Through Latency

For switches that utilize cut-through, latency is measured as the elapsed time between receiving the first bit of information and transmitting the first bit of the resulting outgoing frame. This is referred to as first-in, first-out, or FIFO.

In most user applications, the latency introduced by most switches is low enough to have negligible impact on the response time and performance perceived by the user. End-to-end system processes, however, may add significant time that may be noticed by an end user. Some simple, non-burst LAN protocols require each transmitted packet received be acknowledged before another packet is sent. This type of request/reply protocol will add to the total latency of your network system, and may cause large file transfers and other applications to appear sluggish. Modern LAN protocols, such as TCP/IP, DECnet, and burst-mode NetWare use schemes that allow a number of packets to be sent before acknowledgment, thus alleviating the sluggish appearance of the network.



---

## Congestion Control

Congestion can occur in network switches when more than one input port is contending for a single output port, or when a high-speed port is forwarding to a single, lower speed output port. If the level of congestion is high and lasts for a period of time, packets can be lost due to overflowing buffers.

To alleviate lost packets, dedicated large buffers can be assigned to specific input/output ports. You can also dynamically allocate a shared buffer pool to a group of ports. Switches can implement passive or proactive congestion control measures.

**Queue/drop flow control** is a passive control method that drops a packet if no free buffers are available. A retransmission error will be captured, and the transport layer will transmit the dropped packet again.

A proactive method referred to as **Back Pressure** can also be used to control congestion. A collision signal is transmitted to those nodes or segments that are using most of the buffers. The nodes or segments interpret the collision signal as a collision on the network, causing all nodes to cease transmission. Retransmission will resume in a random period of time. Back Pressure allows retransmissions quicker than the queue/drop method since collisions are detected in the data link layer.

Back pressure should not be used in these cases:

- **When a hub is connected to a switch port.** If the switch transmits a collision signal to the hub, all nodes on the hub will cease transmission. Back pressure should be used only on switch ports connected to individual nodes.
- **When a node communicates to multiple switch ports.** Only one switch port may be congested—and all ports on the switch will not receive the packet.

---

## Sample Switching Topologies

To see samples of switched networks, visit our Reseller Plaza Website.



<http://www.hp.com/key/netreseller>

---

# Index

## Numerics

- 10/100VG LAN adapter card ... 5-42
- 100Base-T
  - hubs ... 5-30
  - switch port module ... 5-30
- 100VG
  - cabling ... 5-35
  - hubs ... 5-34
- 100VG LAN adapter ... 5-42
- 100VG, bandwidth utilization ... 5-35
- 10Base-FL ... 5-10
- 10Base-T ... 5-10
- 10Base-T hub management ... 5-27
- 10Base-T Value Line hubs ... 5-26

## A

- accessories ... 5-44
- Adapter Cards ... 5-42
- adaptive cut-through ... 6-13
- AdvanceStack Assistant ... 5-2–5-5
  - competitive strengths ... 5-5
  - screens ... 5-2
  - top talker ... 5-3
- advantages
  - adding Internet
    - connection ... 4-44
  - basic connection topology
    - 200-1000 nodes ... 4-16
    - 50-200 nodes ... 4-11
    - 5-50 nodes ... 4-7
  - connecting remote sites ... 4-46
  - guaranteed bandwidth
    - connection topology
      - 200-1000 nodes ... 4-39
      - 50-200 nodes ... 4-35
      - 5-50 nodes ... 4-31
  - high-speed connection topology
    - 200-1000 nodes ... 4-27
    - 50-200 nodes ... 4-23
    - 5-50 nodes ... 4-19
- anywhere management ... 2-4
- application types, used in determining network topology ... 4-4
- architecture design ... 6-13
- ASA
  - See* AdvanceStack Assistant
- ATM module ... 5-11

## B

- backbone switch ... 5-10, 5-14, 6-10
- bandwidth ... 5-9
- bandwidth utilization ... 5-3
- bandwidth, increased ... 5-12
- bandwidth, scalable ... 5-8
- basic connections
  - 200-1000 nodes ... 4-14
  - 50-200 nodes ... 4-10
  - 5-50 nodes ... 4-6
- broadcast ... 6-3
- building the LAN ... 4-3
- building the workgroup
  - basic connection topology
    - 200-1000 nodes ... 4-15
    - 50-200 nodes ... 4-11
    - 5-50 nodes ... 4-7
  - connecting remote sites ... 4-46
  - guaranteed bandwidth
    - connection topology
      - 200-1000 nodes ... 4-39
      - 50-200 nodes ... 4-35
      - 5-50 nodes ... 4-31
  - high-speed connection topology
    - 200-1000 nodes ... 4-27
    - 50-200 nodes ... 4-23
    - 5-50 nodes ... 4-19
  - Internet connection ... 4-43

## C

- collapsed backbone ... 5-14
- collision domain ... 5-9
- competitive strengths
  - 100Base-T hubs ... 5-32
  - 100VG hubs ... 5-35
  - 10Base-T hubs ... 5-29
  - AdvanceStack Assistant ... 5-5
  - Hub-12R, Hub-24R and Hub-24T ... 5-38
  - IOS router ... 5-41
  - Switch 2000 ... 5-12
  - Switch 800T ... 5-15
  - Switch208T/224T ... 5-20
- congestion control ... 6-18
- connecting remote sites ... 4-45
  - advantages ... 4-46
  - building the workgroup ... 4-46
  - design notes ... 4-46
  - list of products ... 4-45
  - network monitoring and management ... 4-46

- connection types ... 4-4
- cross-point matrix ... 6-14
- cut-through ... 6-12
- cut-through latency ... 6-17

## D

- department switch ... 5-10, 6-9
- design notes
  - adding Internet connection ... 4-44
  - basic connection topology
    - 200-1000 nodes ... 4-16
    - 50-200 nodes ... 4-12
    - 5-50 nodes ... 4-7
  - connecting remote sites ... 4-46
  - guaranteed bandwidth
    - connection topology
      - 200-1000 nodes ... 4-40
      - 50-200 nodes ... 4-36
  - high-speed connection topology
    - 200-1000 nodes ... 4-27
    - 50-200 nodes ... 4-23
    - 5-50 nodes ... 4-19
- DesignCenter ... 1-3
- desktop/workgroup switch ... 6-9

## E

- early cut-through ... 6-13
- EASE ... 5-2, 5-34, 5-36
- Ethernet LAN switch ... 5-9
- Ethernet, fast ... 5-30
  - See* 100Base-T
- Ethernet, limitations ... 6-1
- expanding the workgroup
  - basic connection topology
    - 200-1000 nodes ... 4-17
    - 50-200 nodes ... 4-13
    - 5-50 nodes ... 4-8
  - guaranteed bandwidth
    - connection topology
      - 200-1000 nodes ... 4-41
      - 50-200 nodes ... 4-37
      - 5-50 nodes ... 4-32
  - high-speed connection topology
    - 200-1000 nodes ... 4-29
    - 50-200 nodes ... 4-24
    - 5-50 nodes ... 4-20
- expansion cabinet,
  - Remote 2C ... 5-40

**F**

## FAQs

- 100Base-T hubs ... 5-33
- 100VG hubs ... 5-35
- LAN Adapters ... 5-43
- Switch 2000 ... 5-13
- Switch 208T/224T ... 5-21
- Switch 800T ... 5-17
- switching hubs ... 5-39
- fast Ethernet ... 5-30
  - See* 100Base-T
- fault-tolerance ... 5-9, 5-12, 5-14, 5-16–5-17
- FDDI ... 5-35
- filtering ... 5-8
- Finds, Fixes, and Inform ... 2-2
- firewall protection ... 5-40
- frame/packet loss rate ... 6-16

**G**

- guaranteed bandwidth connections
  - 200-1000 nodes ... 4-38
  - 50-200 nodes ... 4-34
  - 5-50 nodes ... 4-30

**H**

- high-speed connections
  - 200-1000 nodes ... 4-26
  - 50-200 nodes ... 4-22
  - 5-50 nodes ... 4-18
- HP layer 3 switching ... 6-6
- hub product summary ... 5-22–5-23
- hub, switching ... 5-36
- Hub 12 ... 5-22
- Hub 12M ... 5-22
- Hub-12R ... 5-22, 5-36
- Hub-12TX ... 5-22, 5-30
- Hub-12TXM ... 5-22, 5-30
- Hub-14 ... 5-22, 5-34, 5-36
- Hub-16U ... 5-22, 5-26
- Hub 24 ... 5-22
- Hub-24 TX ... 5-30
- Hub 24M ... 5-22
- Hub-24R ... 5-22, 5-36
- Hub-24T ... 5-22, 5-36
- Hub-24TX ... 5-22
- Hub-7E ... 5-22, 5-34, 5-36
- Hub-8E ... 5-22, 5-26
- Hub-8TXE ... 5-22, 5-30
- Hub-8U ... 5-22, 5-26

**I**

- IGMP ... 5-8, 5-16
- IGMP multimedia traffic
  - control ... 5-12
- Internet connection
  - advantages ... 4-44
  - basic connection topology
    - 200-1000 nodes ... 4-16
    - 50-200 nodes ... 4-12
    - 5-50 nodes ... 4-8
  - building the workgroup ... 4-43
  - design notes ... 4-44
  - guaranteed bandwidth connection topology
    - 200-1000 nodes ... 4-40
    - 50-200 nodes ... 4-36
    - 5-50 nodes ... 4-32
  - high-speed connection topology
    - 200-1000 nodes ... 4-28
    - 50-200 nodes ... 4-24
    - 5-50 nodes ... 4-20
  - list of products ... 4-43
  - network monitoring and management ... 4-44
  - upgrading ... 4-44
- Internet router ... 5-28
- IOS router ... 5-18, 5-28
- IOS router module ... 5-40
- IP multicast ... 5-8, 5-12, 5-16

**J**

- J2415A
  - See* Hub-14
- J2573A
  - See* LAN adapter
- J2585B
  - See* LAN adapter
- J2610B
  - See* Hub-8U
- J2611B
  - See* Hub-16U
- J3100B
  - See* Switch 2000
- J3128A
  - See* Hub-8E
- J3133A
  - See* router
- J3137A
  - See* Hub-7E
- J3138A
  - See* IOS router
- J3175A
  - See* Switch 208T
- J3177A
  - See* Switch 224T

## J3200A

- See* Hub-12R

## J3202A

- See* Hub-24R

## J3204A

- See* Hub-24T

## J3221A

- See* Switch Module

## J3233A

- See* Hub-12TXM

## J3234A

- See* Hub-12TX

## J3235A

- See* Hub-8TXE

## J3245A

- See* Switch 800T

## J3272A

- See* Hub-24TX

## J3300A

- See* Hub 12

## J3301A

- See* Hub-12M

## J3302A

- See* Hub 24

## J3303A

- See* Hub 24M

**L**

- LAN Adapter ... 5-42
- LAN adapter
  - ISA ... 5-42
  - PCI ... 5-42
- LAN, building ... 4-3
- latency ... 6-17
- layer 2 switches ... 6-2
- layer 3 switches ... 6-2, 6-6
- layer 3 switching ... 5-8, 5-12, 5-14, 5-16
- list of products
  - basic connection topology
    - 200-1000 nodes ... 4-14
    - 50-200 nodes ... 4-10
    - 5-50 nodes ... 4-6
  - guaranteed bandwidth connection topology
    - 200-1000 nodes ... 4-38
    - 50-200 nodes ... 4-34
    - 5-50 nodes ... 4-30
  - high-speed connection topology
    - 200-1000 nodes ... 4-26
    - 50-200 nodes ... 4-22
    - 5-50 nodes ... 4-18
  - Internet connection ... 4-43
    - remote site connection ... 4-45
  - load balancing ... 5-39
  - local routing ... 6-4

**M**

management, network  
*See* AdvanceStack Assistant  
 memory architectures ... 6-15  
 MIB I ... 5-2  
 MIB II ... 5-2  
 modes of operation ... 6-11  
 monitor traffic ... 5-2-5-3  
 multicast applications ... 2-6  
 multimedia traffic control  
*See* IGMP  
 multiport trunking ... 2-8

**N**

network management  
*See* AdvanceStack Assistant  
 network monitoring and management  
 basic connection topology  
 200-1000 nodes ... 4-16  
 50-200 nodes ... 4-12  
 5-50 nodes ... 4-7  
 connecting remote sites ... 4-46  
 guaranteed bandwidth connection topology  
 200-1000 nodes ... 4-40  
 50-200 nodes ... 4-36  
 5-50 nodes ... 4-31  
 high-speed connection topology  
 200-1000 nodes ... 4-28  
 50-200 nodes ... 4-24  
 5-50 nodes ... 4-19  
 Internet connection ... 4-44  
 Network Performance  
 Advisor ... 2-3, 5-4  
 network, optimize ... 5-2  
 network, optimizing ... 5-4  
 NIC ... 5-42  
 node count, used in determining  
 network topology ... 4-3  
 number of users, used in determining  
 network topology ... 4-3

**O**

OpenView ... 5-40  
 optimize network ... 2-3, 5-2, 5-4, 5-8

**P**

performance advisor ... 2-3, 5-4  
 port trunking ... 2-8, 5-8-5-9, 5-12,  
 5-14, 5-16-5-17  
 priority ... 5-12  
 proactive networking  
 design too ... 1-2  
 product summary, hubs ... 5-22-5-23  
 product summary, switches ... 5-6-  
 5-7  
 protocol filtering ... 5-8, 5-12, 5-14,  
 5-16

**R**

redundant power supply  
 switching hub ... 5-36  
 Remote 2C expansion  
 cabinet ... 5-40  
 remote office connection  
 basic connection topology  
 200-1000 nodes ... 4-16  
 50-200 nodes ... 4-12  
 5-50 nodes ... 4-8  
 guaranteed bandwidth  
 connection topology  
 200-1000 nodes ... 4-40  
 50-200 nodes ... 4-36  
 5-50 nodes ... 4-32  
 high-speed connection topology  
 200-1000 nodes ... 4-28  
 50-200 nodes ... 4-24  
 5-50 nodes ... 4-20  
 remote sites, connecting ... 4-45  
 advantages ... 4-46  
 building the workgroup ... 4-46  
 design notes ... 4-46  
 list of products ... 4-45  
 network monitoring and  
 management ... 4-46  
 RMON ... 5-2, 5-36, 5-38  
 router ... 5-18, 5-28, 5-36  
 router, IOS ... 5-40  
 RPS, Switch 2000 ... 5-11  
 runt-free, cut-through ... 6-12

**S**

Scaleable bandwidth ... 5-8  
 scaleable traffic control ... 5-14  
 segment switch ... 5-10, 5-14  
 segments ... 5-39  
 server farm ... 5-14  
 shared bus ... 6-15

**shopping list**

basic connection topology  
 200-1000 nodes ... 4-14  
 50-200 nodes ... 4-10  
 5-50 nodes ... 4-6  
 guaranteed bandwidth  
 connection topology  
 200-1000 nodes ... 4-38  
 50-200 nodes ... 4-34  
 5-50 nodes ... 4-30  
 high-speed connection topology  
 200-1000 nodes ... 4-26  
 50-200 nodes ... 4-22  
 5-50 nodes ... 4-18  
 Internet connection ... 4-43  
 remote site connection ... 4-45  
 single collision ... 6-1  
 SNMP ... 5-2  
 store-and-forward ... 6-11  
 store-and-forward latency ... 6-17  
 support ... 2-9  
 switch ... 6-2  
 Switch 2000 ... 5-6, 5-10  
 Switch 2000 modules ... 5-11  
 Switch 2000 RPS ... 5-11  
 Switch 2000, competitive  
 strengths ... 5-12  
 Switch 208T ... 5-6, 5-18  
 Switch 224T ... 5-6, 5-18  
 Switch 800T ... 5-6, 5-14  
 switch architecture ... 6-11  
 switch fabric architectures ... 6-13  
 switch market classes ... 6-8  
 Switch Module ... 5-38  
 switch operation ... 6-2  
 switch performance  
 parameters ... 6-16  
 switch product summary ... 5-6-5-7  
 switch, benefits ... 5-9, 6-1  
 switch, segment ... 5-10, 5-14  
 switch, why use ... 5-8, 6-1  
 switching comparisons ... 6-8  
 switching hub ... 5-36  
 Hub-12R ... 5-36  
 Hub-24R ... 5-36  
 Hub-24T ... 5-36  
 IOS router ... 5-36  
 management pack ... 5-38  
 segments ... 5-36  
 stackable ... 5-36  
 stacking ... 5-36  
 switch module ... 5-36  
 switching hubs  
 load balancing ... 5-39  
 segments ... 5-39

## T

- throughput ... 6-16
- top talker ... 5-3
- topology
  - basic connections
    - 200-1000 nodes ... 4-14
    - 50-200 nodes ... 4-10
    - 5-50 nodes ... 4-6
  - guaranteed bandwidth connections
    - 200-1000 nodes ... 4-38
    - 50-200 nodes ... 4-34
    - 5-50 nodes ... 4-30
  - high-speed connections
    - 200-1000 nodes ... 4-26
    - 50-200 nodes ... 4-22
    - 5-50 nodes ... 4-18
  - types of network connections ... 4-4
- topology selection
  - based on application types ... 4-4
  - based on number of nodes ... 4-3
  - questions to ask the client ... 4-3
- traffic monitor ... 5-2-5-3
- traffic reduction ... 5-12
- traffic, sampling ... 5-4
- trunking, port ... 2-8, 5-8
- types of connections ... 4-4

## U

- upgrading the Internet connection ... 4-44
- upgrading workgroups
  - basic connection topology
    - 200-1000 nodes ... 4-17
    - 50-200 nodes ... 4-13
  - guaranteed bandwidth connection topology
    - 200-1000 nodes ... 4-41
    - 50-200 nodes ... 4-37
    - 5-50 nodes ... 4-32
  - high-speed connection topology
    - 200-1000 nodes ... 4-29
    - 50-200 nodes ... 4-24
    - 5-50 nodes ... 4-20
- utilization, reducing ... 5-4

## V

- Value Line hubs ... 5-26
- virtual LAN
  - See* VLAN
- VLAN ... 5-5, 5-8, 5-12, 5-16

## W

- website ... 1-2
- What's new in 1998 ... 1-1
- workgroup, building
  - basic connection topology
    - 200-1000 nodes ... 4-15
    - 50-200 nodes ... 4-11
    - 5-50 nodes ... 4-7
  - connecting remote sites ... 4-46
  - guaranteed bandwidth connection topology
    - 200-1000 nodes ... 4-39
    - 50-200 nodes ... 4-35
    - 5-50 nodes ... 4-31
  - high-speed connection topology
    - 200-1000 nodes ... 4-27
    - 50-200 nodes ... 4-23
    - 5-50 nodes ... 4-19
- Internet connection ... 4-43

Documentation and literature is continuously updated to insure that HP's customers are provided with the most recent information. As such, literature part numbers requested will change over time. The most current, up-to-date information will be provided.

Windows®, MS Windows®, and Microsoft® are U.S. registered trademarks of Microsoft Corporation. UNIX® is a registered trademark of the Open Group. Cisco Systems is a trademark of Cisco Systems, Inc.

Technical information in this document is subject to change without notice.

© 1997–1998 Hewlett-Packard Company. All rights reserved. Reproduction, adaptation, or translation without prior written permission is prohibited except as allowed under the copyright laws.

Printed in USA 2/98

Part Number 5966-2254EUC