

BACK-TO-SCHOOL
GUIDE, P. 80

IS YOUR MAC READY FOR Y2K? PAGE 68

OCTOBER 1999

Macworld

THE MACINTOSH® AUTHORITY
www.macworld.com

Meet the iBook

Secrets of the
iBook, Including:

- Wireless Networking
- Hidden Features
- Exclusive Details



See Page 62

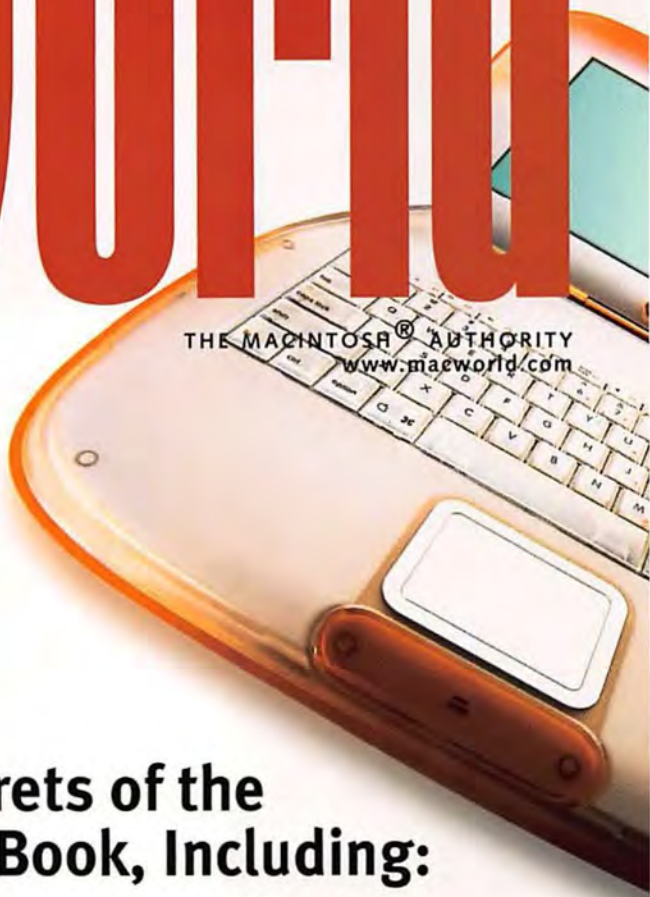



www.lacie.com/mwfw.htm FireWire Hard Drive™ and the LaCie logo are trademarks of LaCie, Ltd. ©1999 LaCie, Ltd. All rights reserved.
FireWire and the FireWire logo are trademarks of Apple Computer, Inc., registered in the U.S. and other countries.
The caffeine molecule. If, instead of atoms, it were made of light bulbs.

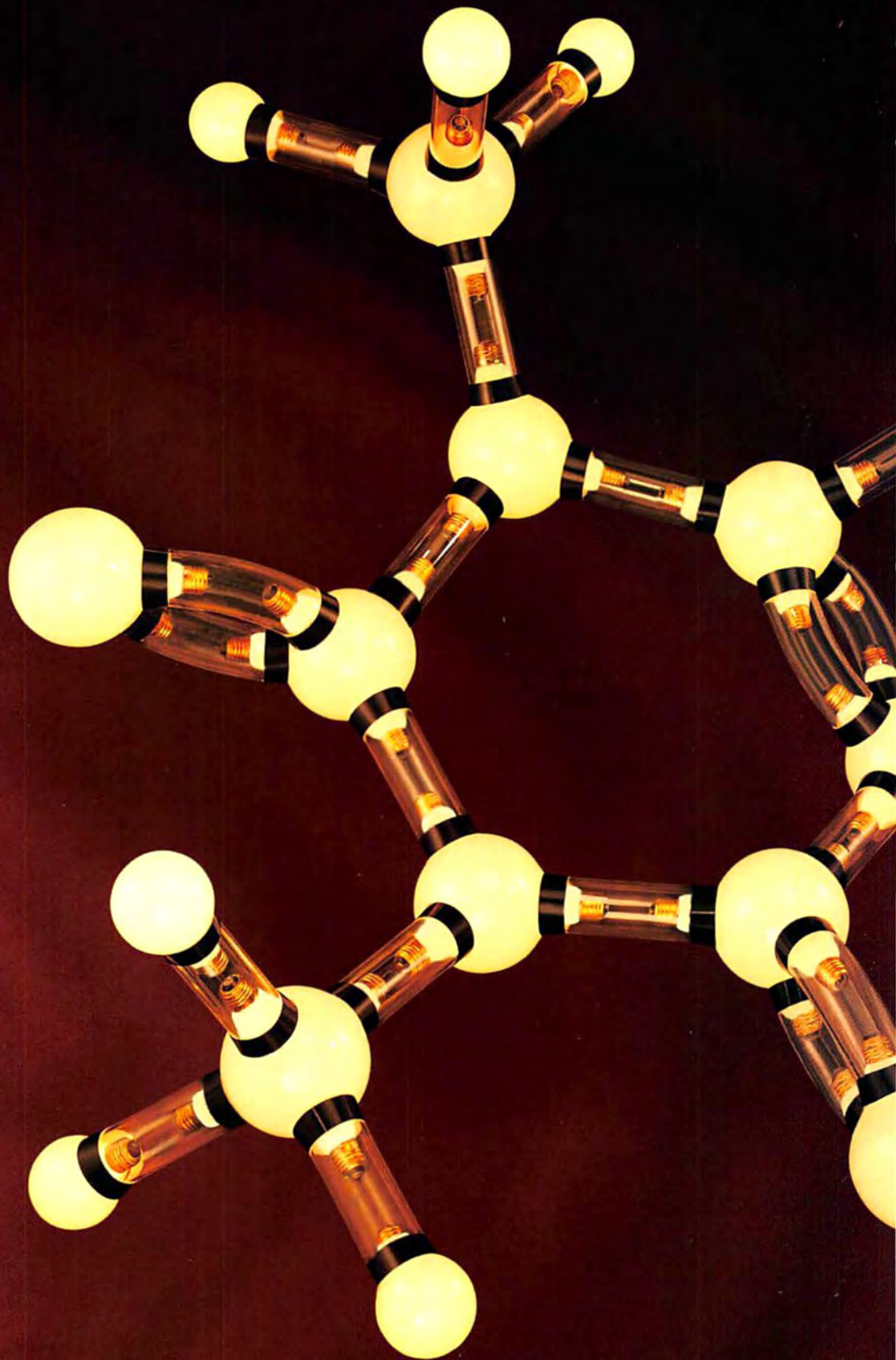



CONNECTED.

Get faster access to your ideas with the LaCie FireWire Hard Drive™. It can send data along its FireWire™ connector at 400 Mbps while linked to up to 63



FireWire enabled peripherals. And it's still hotswappable. Plus, it's available up to 36GB. All of your peripherals working together as one. Now who'd have thought of that?

LACIE

Made for ideas.

Macworld

Incorporating MacUser

Features

Cover Story

62 Meet the iBook

BY DAVID POGUE Apple's portable iMac is colorful and wireless and fits in your backpack.

68 01/01/00

BY GEOFF DUNCAN We've all heard the hype about Y2K. But as a Mac user, you won't have to worry—or will you?

74 Photoshop Discovers the Web

BY JASON SNELL Photoshop has never been particularly Web-savvy. Fortunately, version 5.5 changes all that. Take a tour of its new features for Web and print pros alike.

80 Get Smart

Looking for fun, useful learning tools for kids of all ages? Let *Macworld's* annual back-to-school guide take you to the head of the class.



Apple rewrites the laptop for consumers, page 62.



Take out your No. 2 pencil—*Macworld* goes back to school, page 80.



Macs and the millennium bug: what do you have to fear? page 68.

Create

Motion

95 Master Streaming with QuickTime 4

BY JIM HEID Learn how to make the most of QuickTime 4's new audio- and video-streaming capabilities.

Web

99 Web Graphics Made Easy

BY TOM NEGRINO Even if you're not a professional designer, you can use Adobe ImageStyler to beautify your site with great graphics.

Graphics

102 Make Your Pictures Move

BY MIKE WOOLDRIDGE A behind-the-scenes look at how photographer Jeff Schewe puts motion into his still images.

ON THE COVER

Photography by
Lisa Quinones/Black Star

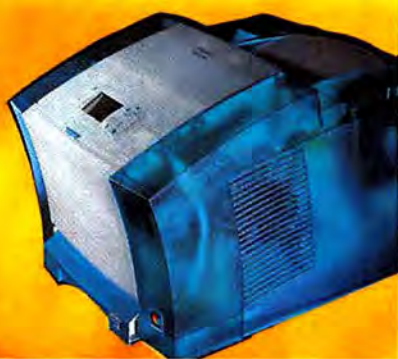

A solid-ink printer in shades of iMac, page 29.

News

- 27 Microsoft Preps Web Upgrades**
Outlook Express gets a junk-mail filter, while Internet Explorer bids on online-auction features.
- 28 Macworld Expo Best of Show**
Macworld's editors pick the hottest products introduced at Macworld Expo New York.
- 28 Get Ready for QTV**
Apple unveils QuickTime TV, a Webcast network that builds on the live-streaming capabilities of QuickTime 4.
- 29 Printing in Blue and White**
Tektronix brings the iMac look to its Phaser 840 solid-ink printer.
- 29 Kodak Doubles the Megapixels**
Kodak joins the ranks of manufacturers offering two-megapixel digital cameras.



Take the easy path to Mac OS 8.6, page 89.

Opinion

- 17 Letters**
- 23 The Vision Thing**
BY ANDREW GORE The iBook may herald the golden age of wireless.
- 59 The Game Room**
BY CHRISTOPHER BREEN Great games are on their way for the holidays. Here's a sneak peek.
- 168 The Desktop Critic**
BY DAVID POGUE Is Steve Jobs the computer industry's answer to Casey (at the bat)? You be the judge.
- 10 How to Contact Macworld**

Get the picture with a 17-inch monitor, page 32.



Reviews

- 32** ★★★★★ Iiyama Vision Master Pro 410; ★★½ MGC Technologies MGC-790; ★★★ NEC Technologies MultiSync E750; ★★½ Optquest V75; ★★★ Philips 107MB; ★★★ ViewSonic GF775
17-inch CRT monitors compared
- 34** ★★½ QuickTime 4 Pro
Multimedia system software
- 35** ★★★★★ Flash 4
Web-animation software
- 36** ★★½ Best Data Smart One USB 56K; ★★½ Boca Research TelePort USB 56K; ★★★ Diamond Multimedia SupraExpress 56 USB; ★ Viking 56K USB
USB 56K modems compared
- 38** ★★½ Farallon HomeLine Starter Kit
Home-networking kit

Secrets

- 89 Mac OS 8.6 Optimization Tricks**
BY TED LANDAU The worry-free way to bring your Mac up to OS 8.6.
- 91 Quick Tips**
BY LON POOLE Tips, tricks, and shortcuts.

- 40** ★★½ MacDrive 98 3.0
Cross-platform disk mounter
- 42** ★★★★★ HouseCall 5.0; ★★★ Timbuktu Pro 5.0
Remote-control software
- 44** ★★★★★ Mathematica 4.0
Math software
- 46** ★★★ XLR8 InterView
USB video-capture device
- 48** ★★★★★ Olympus C-2000 Zoom
Two-megapixel digital camera
- 50** ★½ RichLink Author 2.1
Hypertext authoring system
- 52** ★★★★★ GeeThree.com Stealth Serial Port
Serial-port adapter
- 54** ★★★★★ RealBasic 2.0.2
BASIC programming environment
- 56** ★★★★★ Falcon 4.0
Flight-simulator game

**NO LINES. NO PARKING-LOT GRIDLOCK.
INSTANT SERVICE. 24-HOUR SUPPORT.**

WHAT KIND OF STORE IS THIS?

The shopper-friendly kind: a Virtual Printer Store. You don't get here by car or bus. You come by phone or mouse instead. And you couldn't stand in a line, get lost in a crowd, or be ignored by a store clerk if you tried.

At the Virtual Printer Store you buy your printer direct from the people who made it. So you pay only for what you need (the printer), and not what you don't (the middleman).

And there's another important difference after you leave. At conventional stores you get demoted from customer to stranger. At ours you become a virtual client.

We offer free technical support 24 hours a day, 7 days a week — for the entirety of the one-year warranty. And if

you run up against a problem we can't solve, our Platinum Exchange Warranty Program guarantees you a replacement printer by the next business day. (All our printers come with a thirty-day, money-back guarantee as well.)

Finally, we offer printers good enough to sell themselves — because they have to. Printers that turn out vivid halftones, poster-sized graphics, printshop-quality text, and perform various other noteworthy feats noted here.

Now, what are your chances of finding a conventional store that offers all that? Virtually nonexistent.



ELITE 12/600 USB

12 pages per minute
600 x 600 dpi resolution
Maximum Print Area 8.5" x 14"
Letter, legal, envelope
250-sheet Universal Tray
PostScript® Level 2 compatible, PCL 5
35 PostScript fonts, 15 PCL fonts,
45 downloadable fonts
RAM expandable to 64 MB
1st year Platinum Exchange
USB (cable included),
Bi-directional Parallel

2nd Paper Feeder¹
(includes 500-sheet Universal Tray) Add \$ 299

2nd year Platinum Exchange³ Add \$ 89

\$699



ELITE XL 20 Series

20 pages per minute
600 x 600 dpi resolution
Maximum Print Area 12.6" x 35.1"
Letter, tabloid, legal, envelope, poster
500-sheet Universal Tray
PostScript Level 2 compatible, PCL 5
35 PostScript fonts, 15 PCL fonts,
250 downloadable fonts
RAM expandable to 64 MB
1st year Platinum Exchange
EtherTalk®, LocalTalk®, NetWare®, TCP/IP
Ethernet (10 BaseT, AAUI),
Bi-directional Parallel

2nd or 3rd Paper Feeder²
(includes 500-sheet Universal Tray) Add \$ 299

2nd year Platinum Exchange³ Add \$ 179

\$1599

Lease \$56 Month/36 months⁴

\$1899 800 dpi version

Lease \$67 Month/36 months⁴

\$2199 1200 dpi version

Lease \$77 Month/36 months⁴



ELITE 12N Series

12 pages per minute
600 x 600 dpi resolution
Maximum Print Area 8.5" x 14"
Letter, legal, envelope
250-sheet Universal Tray
PostScript Level 2 compatible, PCL 5
35 PostScript fonts, 15 PCL fonts,
45 downloadable fonts
RAM expandable to 64 MB
1st year Platinum Exchange
EtherTalk, TCP/IP
USB, Ethernet (10 BaseT),
Bi-directional Parallel

2nd Paper Feeder¹
(includes 500-sheet Universal Tray) Add \$ 299

2nd year Platinum Exchange³ Add \$ 99

\$849

\$949 1200 dpi version



Also available in LocalTalk versions



ELITE XL 8 Series

8 pages per minute
600 x 600 dpi resolution
Maximum Print Area 11" x 17"
Letter, tabloid, legal, envelope
250-sheet Universal Tray
PostScript Level 2 compatible, PCL 5
35 PostScript fonts, 15 PCL fonts,
45 downloadable fonts
RAM expandable to 64 MB
1st year Platinum Exchange
EtherTalk, LocalTalk, TCP/IP
Ethernet (10 BaseT, 10 Base2),
Parallel

2nd year Platinum Exchange³ Add \$ 139

\$999

Lease \$50 Month/24 months⁴

TO ORDER 1.800.422.7777 OR WWW.GCCTECH.COM



THE VIRTUAL PRINTER STORE™

Choose 43 at www.macworld.com/getinfo



GCC Technologies is a registered trademark of GCC Technologies, Inc. All other trademarks or registered trademarks are trademarks of their respective companies. Supports one additional paper feeder. ¹ Supports two additional paper feeders. ² Platinum Exchange pricing is at point of purchase only. ³ Leasing provided by independent leasing companies to qualified customers. Lease payments based on 24-month and 36-month terms. Lease terms subject to change without notice or obligation. ⁴ All GCC printers are Mac OS compatible. ⁵ NetWare is supported on all 20 Series & Elite 12/1200N printers. ⁶ Windows certification is for the 20 Series printers only.

Keycode 910MWD1

Macworld

EDITOR IN CHIEF Andrew Gore
EXECUTIVE ASSISTANT TO THE EDITOR IN CHIEF Savraj Benedict

EDITORIAL

EDITOR Michael Penwarden
SENIOR EDITOR/NEWS AND REVIEWS Stephen Beale
SENIOR EDITOR/DEPARTMENTS Nancy Peterson
SENIOR EDITOR/FEATURES Jason Snell
SENIOR ASSOCIATE EDITORS Allyson Bates,
Linda Comer,
Scholle Sawyer
ASSOCIATE EDITOR Brooke C. Wheeler
ASSISTANT EDITORS Michael Gowan,
Jonathan Seff

CONTRIBUTING EDITORS

Henry Bortman, Christopher Breen, Bruce Fraser, Ted Landau,
Deke McClelland, Rik Myslewski, Tom Negrino, David Pogue,
Lon Poole, Stephan Somogyi, Franklin N. Tessler

INTERNATIONAL EDITORS

Steven Noble, Australia; Bernard Le Du, France; Andreas
Borchert, Germany; Enrico Lotti, Italy; Yoshio Moriya, Japan;
Tomasz Bitner, Poland; Daniel de Blas, Spain; Lennart
Håkansson, Sweden; Fred Jame, Taiwan; Bahattin Apak, Turkey;
Simon Jary, United Kingdom

LAB

TECHNICAL DIRECTOR Jeff Pittelkau
LAB DIRECTOR Kristina De Nike
SENIOR LAB ANALYST Jeffy K. Milstead,
Kevin Mitchell
ASSOCIATE LAB ANALYST Gil Loyola
INVENTORY COORDINATOR Ulyssis Bravo

COPY EDIT

MANAGING EDITOR Claire H. Breen
ASSISTANT MANAGING EDITOR Paul-Michael King
COPY CHIEF Jon Zobenica

ART AND DESIGN

DESIGN DIRECTOR Eleanor Leishman
ART DIRECTOR Sylvia Chevrier
ASSOCIATE DESIGNERS Martha Katt,
Michael Rattary
DESIGN ASSOCIATES Jackie Goodman,
Jonathan Woolson

ONLINE

VICE PRESIDENT, SALES, & PUBLISHER Matt Sweeney
DIRECTOR OF CONTENT Matthew Rothenberg
SENIOR ONLINE EDITOR Philip W. Dyer
CONTENT ENGINEER Jeff Cheney
ASSISTANT CONTENT ENGINEER Ron Neal
ONLINE AD PRODUCTION MANAGER Steve Spingola



iCart™
from
Anthro



ANTHRO
www.anthro.com



Short iCart: \$149; Tall iCart: \$199; Great accessories. Call us at 800-325-3841.

add life to the web



Flash

OVER 100 MILLION SERVED

Flash

websites have
mass appeal.

Flash feeds the masses. Already the standard
with over 100 million users, people drive
through Flash Websites every day.*

Serve up a high-impact experience with Flash.

www.macromedia.com



macromedia

DIRECTOR SHOCKWAVE DREAMWEAVER FIREWORKS (FLASH) (FREEHAND) GENERATOR

Choose 36 at www.macworld.com/getinfo

© 2000 Macromedia, Inc. All rights reserved. Macromedia, the Macromedia logo, Flash, and Freehand are trademarks or registered trademarks of Macromedia, Inc. All other trademarks or registered trademarks are the property of their respective owners. *February 1999 research by Forrester, Brown, & Partners, an independent market research firm, showed that over 100 million web browsers have the Flash Player already installed. For details, please visit www.macromedia.com/flashplayer

Project Scheduling Made Easy!

DON'T TELL MY BOSS

I'm not a project management expert, but everyone thinks I am. Most of my time is spent completing tasks, so I need a scheduling tool that's easy, fast, and flexible.

FastTrack Schedule 6.02 fills the bill. It keeps me organized and in control displaying all my project details in rich, colorful timelines. FastTrack Schedule provides just the right amount of power because it's more sophisticated than day-planners, but *easier to use and half*

\$199* *the price of traditional, high-end project managers.*

The presentation-quality schedules clearly illustrate project objectives and deadlines keeping team members and clients informed and up-to-date.

In a single schedule, I can outline multiple projects, make assignments, track cash flows, set-up dependencies—even add graphics. Whether I use it once a week or every day, FastTrack Schedule makes project scheduling easy.

For the free Demo CD, more info, or to place an order call **800-450-1982**.

NEW Version 6.02

- ExpressDate™ • FastSteps™
- Open/Export MS Project MPX files
- Full AppleScript Support
- Histograms • Hyperlinks
- and much more...

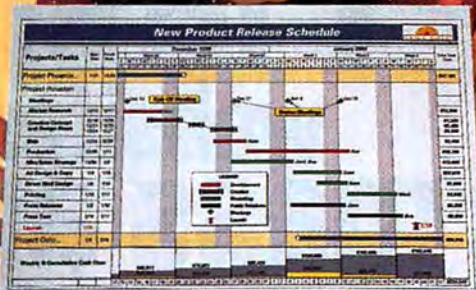

Macworld

PRESIDENT AND CEO Colin Crawford
 ASSISTANT TO THE CEO Sharon Sanderson
 CHIEF FINANCIAL OFFICER Stephen Daniels
 BUSINESS MANAGER Eos de Feminis
 ACCOUNTING COORDINATOR Ronda Bittner
 DIRECTOR OF HUMAN RESOURCES Sue Murphy
 HUMAN RESOURCE MANAGER Marisa Chwo

DISPLAY ADVERTISING SALES

VICE PRESIDENT, SALES, & PUBLISHER Matt Sweeney
 ASSOCIATE PUBLISHER Steve Plevin (415/243-3509)
 SALES & MARKETING COORDINATOR Karla Kyrias (415/278-8542)
 SALES ASSISTANT Katherine Lebioda (415/243-3577)
 NATIONAL ACCOUNTS MANAGER Jessica Ross (415/243-3583)
 ACCOUNT EXECUTIVE Coretta Wright (415/243-3615)
 NATIONAL ACCOUNTS MANAGER Sara Culley (970/327-4499)
 ACCOUNT EXECUTIVE Margaret Level Green (415/243-3582)
 EASTERN ADVERTISING DIRECTOR Cynthia Ramsey (973/243-1197)
 NATIONAL ACCOUNTS MANAGER Paul Bonarrigo (508/533-4020)
 ACCOUNT EXECUTIVE Jo Zottarelli (516/277-4134)
 SHOPPER ACCOUNT MANAGER Niki Stranz (415/243-3664)
 SHOPPER ACCOUNT MANAGER Carol Johnstone (415/243-3691)
 SHOPPER ADMINISTRATIVE ASSISTANT Alissa Mach (415/243-3628)

RESEARCH

SENIOR RESEARCH ANALYST Phillip Hihlbert

MARKETING

SENIOR MARKETING MANAGER Francesca Koe
 TRADE SHOW/EVENTS MANAGER Nancy Galanty
 MARKETING MANAGER Diane Powers

MACWORLD GLOBAL PRODUCT SUPPORT CENTER

COORDINATOR Sharon Sanderson

PRODUCTION

VICE PRESIDENT OF MANUFACTURING Anne Foley
 PRODUCTION DIRECTOR Cynthia Neustadt
 MANUFACTURING TECHNICAL DIRECTOR Clayton Haberman
 DIGITAL AD COORDINATORS Russ Nordmeyer,
 Mae Scott
 AD SALES COORDINATOR Rick Sandoval

FastTrack Schedule

Version 6.02

Schedule Tomorrow's Success Today.™ AEC SOFTWARE

© 1999 AEC Software Inc. All rights reserved. Corporate names and trademarks stated herein are the property of their respective owners. *Estimated Street Price is \$199, prices may vary at individual retailers. Outside the United States, please call (703) 450-1982 for information.



Macworld is a publication of Mac Publishing, L.L.C. Macworld is an independent journal not affiliated with Apple Computer, Inc. Macworld, MacUser, MacWeek, Macworld Interactive, Macworld Shopper, MW, MW Lab, MW Shopper, The Desktop Critic, Expert Graphics, Quick Tips, Star Ratings, Buyers' Tools, Streetwise Shopper, and Conspicuous Consumer are registered trademarks of Mac Publishing, L.L.C. Apple, the Apple logo, Mac, and Macintosh are registered trademarks, and MacLetter and PowerBook are trademarks, of Apple Computer, Inc. Printed in the United States of America. Copyright © 1999 Mac Publishing, L.L.C. All rights reserved.

Choose 203 at www.macworld.com/getinfo



TRY IT & BUY IT!

Download the demo and order online today at www.aecsoft.com

Presenting a revolutionary force in television. YOU.

ReplayTV™ Imagine having the freedom to watch your favorite shows on your schedule. The power to control live TV. The excitement of a truly personal television experience.

Presenting ReplayTV, a revolutionary set-top box that records your favorite shows on a hard disk automatically, every time they're on. No tapes.

No hassles. ReplayTV works with an intelligent programming service so you can create your own personal channels based on your favorite shows, actors or themes. ReplayTV finds and records your shows so you can watch them on-demand with full VCR-style controls. It's easy. It's automatic. It's guaranteed.

You can also pause, rewind and use instant replay on live TV. Say the phone rings in the middle of *Friends*®. Simply hit pause and take your call. Then, hit play and you haven't missed a beat. For just \$699 and no monthly fees, ReplayTV will revolutionize the way you watch television. It's television made personal.

1.877.ReplayTV
replaytv.com



All prices shown are subject to change. Price does not include applicable state and local sales tax or shipping to the recipient's destination. ©1999 Replay Networks, Inc. All rights reserved. ReplayTV, the Replay logo, and Primetime. Anytime. are trademarks of Replay Networks, Inc. All other trademarks or registered trademarks are property of their respective holders. TV not included. Code: 1127

replay
Primetime. Anytime.™

Choose 20 at www.macworld.com/getinfo

PowerBook® or Desktop VST has the portable solutions you are looking for.



Announcing our new FireWire Full Height Drives in 10, 14 and a whopping 22GB. Also, check out our FireWire Zip250 Drive at www.vsttech.com



4, 6, 8, 10 & 14GB FireWire Hard Drives in a lightweight, portable & convenient size.



USB Floppy Disk Drive



Go to our web site to see our newly announced USB Hard Drives!

VST Products are available at www.vsttech.com

Apple, Macintosh, iMac, and PowerBook are registered trademarks of Apple Computer, Inc. Zip is a registered trademark of Imation Corp. SuperDisk is a trademark of Imation, Corp.



Choose 73 at www.macworld.com/getinfo

furniture for the way you do business.
as individual as you are.



1.800.688.2446 x622

www.agiodesigns.com/mw

free catalog

AGIO DESIGNS™

Choose 265 at www.macworld.com/getinfo

Macworld

HOW TO CONTACT MACWORLD

Subscription Services

Phone 800/627-2247 or
303/665-8930, North America only
303/604-7445, outside North America
U.S. Mail Macworld Subscription Services
P.O. Box 54529, Boulder, CO 80322-4529
World Wide Web www.zdnet.com/zdsubs/macworld/service

Subscription Rates

The one-year (12-issue) subscription rate is \$34.97 in the United States and \$54.97 for all other countries (send \$104.97 for air mail). The rate for a one-year (12-issue) subscription with the monthly CD-ROM is \$49.97 in the United States and \$69.97 for all other countries (air mail not available at this time). Checks must be made payable in U.S. currency to Macworld. Please allow 6 to 8 weeks to receive your first issue.

Back Issues of Macworld

Back issues (subject to availability) are \$8 per issue for U.S. delivery (\$12 outside the United States); prepayment in U.S. currency to Macworld is required. Send check or money order to Back Issues Department, Ziff-Davis Inc., P.O. Box 53131, Boulder, CO 80322-3131.

Reprints and Permissions

You must have permission before reproducing any material from Macworld. Write to Macworld, Reprints and Permissions, 301 Howard St., 16th Fl., San Francisco, CA 94105; include a phone number. To order reprints of your company's editorial coverage, call Reprint Management Services at 717/399-1900; fax 717/399-8900; e-mail sales@rmsreprints.com.

Mailing Lists

We periodically make lists of our customers available to mailers of goods and services that may interest you. If you do not wish to receive such mailings, please write to us and include a copy of your mailing label.

Macworld on Microfilm

Macworld is available on microfilm and microfiche from UMI, 300 N. Zeeb Rd., Ann Arbor, MI 48106-1346; 734/761-4700.

Macworld Editorial

The editors of Macworld welcome your tips, compliments, or complaints. Stories and product reviews from past issues can be located at www.macworld.com. We are unfortunately unable to look up stories from past issues; recommend products; or diagnose your Macintosh problems by phone, e-mail, or fax. Contact Apple toll-free at 800/538-9696, ext. 500, for information on user groups in your area.

Our offices are located at 301 Howard St., 16th Fl., San Francisco, CA 94105; 415/243-0505, fax 415/442-0766.

LETTERS TO THE EDITOR Direct all comments and suggestions regarding any aspect of the magazine to letters@macworld.com. Due to the high volume of mail received, we can't respond personally to each letter. We reserve the right to edit all submissions. All letters published in Macworld or Macworld Online become the property of Macworld.

QUICK TIPS Send your questions or tips on how to use Mac computers, peripherals, or software to Macworld, Quick Tips, 301 Howard St., 16th Fl., San Francisco, CA 94105; fax 415/442-0766; e-mail quicktips@macworld.com. Please include your name, address, and telephone number.





Use it



or lose it.



Introducing AIWA's USB Backup Tape Drive for iMAC™ and G3. With up to 8 GB* of capacity and an MSRP of only \$249, you've got absolutely nothing to lose. Look us up at www.aiwa.com/csd for more information.

Choose 299 at www.macworld.com/getinfo

aiwa
COMPUTER SYSTEMS DIVISION



IT TAKES ONLY
ONE LITTLE THING
TO RUIN AN ENTIRE
PRESENTATION.

If your reputation hinges on accuracy, consider that Tektronix has been making color printers for more than 15 years. You might also like to know about the Phaser® 780 color printer.

It's loaded with color management tools that take the guesswork out of getting what you want. There's our exclusive PhaserMatch™ ICC software, which allows you to match the output of a specific press, paper, or ink. Want to know how your work is going to look on newsprint? Use one of the newsprint profiles, or create your own using International Color Consortium standards. And it supports ColorSync, so what you see on your screen is what comes out of your printer.

Avoid embarrassment.
Call toll-free 1-877-362-6567
ext. 1616. Or visit

www.tektronix.com/Phaser780x1616



Tektronix®

© 1999 Tektronix, Inc. Tektronix and Phaser are registered trademarks and PhaserMatch is a trademark of Tektronix, Inc. ColorSync is a trademark of Apple Computer, Inc.

Choose 95 at www.macworld.com/getinfo

Think Faster!

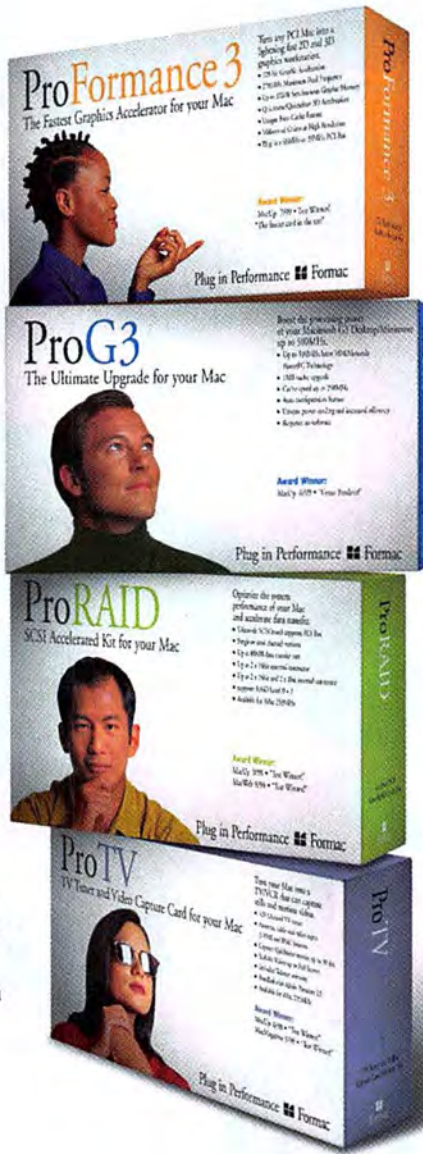

ProFormance 3
 The Fastest Graphic Accelerator for your Mac will turn any PCI Mac into a lightning fast 2D and 3D graphics workstation.

ProG3
 The Ultimate Processor Upgrade for your Mac can boost the processing power of any Macintosh G3 up to 500MHz - at a fraction of the cost of a new system.

ProRAID
 This SCSI Accelerator Kit is the ultimate I/O solution to optimize high-speed data transfer between your Mac and SCSI peripherals up to 80MB/s data transfer rate.

ProTV
 Turn your Mac into a full function TV/VCR that can capture still frames and full motion video.

Designed specifically for the Mac, our products will turn your friendly Mac into a lightning fast, incredibly powerful media creation computer. Formac's Performance Suite is the ultimate, cost-effective upgrade package. Don't wait. With Formac you don't have to. Get your Mac to think as fast as you do, just visit www.formac.com and learn how easy it can be.





From the
creators of
Nanosaur
comes...

BUGDOM™

"Ground-breaking visuals and game play...playable by both
child and adult, male and female" - Inside Mac Games



Try the **FREE** Demo!

Buy **BUGDOM** On-Line Today!

at

www.pangeasoft.net/bug



www.toucanstudio.com



www.pangeasoft.net

Macworld

SUBSCRIPTION SAVINGS V O U C H E R

This voucher entitles you to save up to **74% off** the cover price when you subscribe to MACWORLD.

BONUS: the *Clip Art CD-ROM* — **FREE** with your paid order.

CHECK ONE:

- 2 YEARS (24 ISSUES) \$49.97 — SAVE 74%**
 1 YEAR (12 ISSUES) \$34.97 — SAVE 64%

Name _____ (Please Print) 4SNP2

Company _____

Address _____

City _____ State _____ Zip _____

E-Mail Check box if you would like to receive periodic e-mail offers from carefully screened providers of quality goods and services.

SAVINGS SUMMARY

ANNUAL COVER PRICE
\$95.88

YOUR SPECIAL RATE
\$34.97

SAVINGS OF:
\$60.91

BONUS
CLIP ART
CD-ROM

- Payment enclosed.
 Bill me later.

Annual newsstand price \$95.88. Non-U.S. orders add US\$20 postage; Canadian GST included.
Your FREE software will be shipped upon payment. This offer does not include monthly CD-ROMs.

Check us out on the Web —
<http://www.macworld.com>



NO POSTAGE
NECESSARY
IF MAILED
IN THE
UNITED STATES

BUSINESS REPLY MAIL

FIRST-CLASS MAIL PERMIT NO. 66 BOULDER, CO

POSTAGE WILL BE PAID BY ADDRESSEE

Macworld[®]

Subscription Department
PO Box 54506
Boulder, CO 80323-4506



Letters

Worthy Challenger

I WAS VERY INTERESTED IN YOUR comparison of the iMac and a PC ("The iMac Challenge," July 1999). I am certified on various Microsoft products, including Windows 95, and I have been considering purchasing a Mac. I am well aware of the strengths of the Macintosh in graphic design and audio editing. By adding a Mac to my collection, I think I would have the best of both worlds—familiarity with the PC along with the usability of the Mac.

Your comparison, although geared more toward the first-time user, was quite informative and honest, and I was more interested than ever in purchasing a Macintosh after reading it. The 266MHz iMac's performance versus that of the 366MHz PC impressed me the most. I don't know if a G3 is comparable to a Celeron as opposed to a Pentium II, but nevertheless, the numbers are impressive.

JASON A. DANIELS
Cape Coral, Florida

ALTHOUGH I AM REALLY NOT THE iMac's target buyer, I was very interested in *Macworld's* iMac-versus-Gateway-PC tests. There was a great deal of valuable information in the article, and I hope both Apple and the PC manufacturers pay attention to it. Although the tests were well organized and thoughtful, there was one crucial element missing: finding out what happens to these users after they spend a month using each computer.

Consider a few more tests that would really point out the Mac's superiority, which is in consistency. For example, have users install a new software application and then launch and use that application. Or add a peripheral device to the computer, configure it, and use it. Now add



another peripheral of a different kind, configure it, and use it.

In these more everyday tests, the Mac is far superior to the PC because everything behaves pretty much the same. Menus (such as File and Edit) are always there and always contain certain items. Peripherals are generally straightforward and have similar installation processes, and most programs work basically the same way—even very different programs such as graphics and word-processing applications.

JOHN L. KUNDERT-GIBBS
Asheville, North Carolina

Due to time constraints, we were unable to document the users' long-term experiences. We hope in the future to chronicle iMac and PC users' experiences over a longer period of time.—Ed.

IN "THE iMAC CHALLENGE," YOU forgot one important test—the Mom test. Which kind of computer would you rather have your mother buy, given that

you will act as the technical-support person for the life of the machine?

MATT BALL
Pittsburgh, Pennsylvania

Up in Arms over OS X Server

MACWORLD HAS REALLY LOST ITS way! You conduct a review of Mac OS X Server (*Reviews*, July 1999), including a graph with the dooming headline "As a Web Server, OS X Lags," and give OS X Server a low mark for "mediocre performance for file and Web serving." Then at the end you mention that the comparison was to a large-scale, multi-processor NT server and that a smaller NT-server configuration comparable to the Mac tested wasn't available at press time. That's not exactly comparing Apples to apples, is it?

This first-generation Mac OS X Server may not be the server of choice for huge transaction-intensive sites yet. However, those sites are not the majority on the Web. For the more common small-to-medium-size sites and intranets for labs, classrooms, and small graphics shops where networked media is important—the traditional core of the Macintosh user base—OS X Server is a superior product. And OS X Server is not built on a house of cards, as is Windows NT, with its bloated code that dooms it to technological extinction. Clearly this clean offering created on a solid code foundation from a proven technology leader has a much brighter future than NT, and a publication that cared about its readers' pocketbooks would recommend it.

LAUREL KASHINN
Grafton, Wisconsin

continues

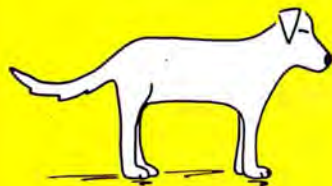

REMOVES SCRATCHES.

One second your photo has a scratch. The next, it doesn't. That's the power of Digital ICE™, revolutionary technology that instantly removes scratches, dust and fingerprints from scans. If you're looking to save a great photograph, look no further than Nikon. Because no one else has Digital ICE. Call 1-800-52-NIKON or visit our Web site at www.nikonusa.com.

Nikon Coolscan® film scanners
with Digital ICE



©1999 Nikon Inc. Digital ICE is a trademark of Applied Science Fiction.

Choose 59 at www.macworld.com/getinfo

To clarify our test configuration for the Mac OS X Server review: both the NT server and the Solaris server were dual-processor systems. We feel comparing Mac OS X Server to these configurations is reasonable, because dual processors are considered standard for businesses concerned with Web-server performance.

For more opinions on OS X Server's suitability in offices and labs, see our continuing coverage at www.macworld.com/1999/10/opinion/letters/osx.html.—Ed.

Palm Reading

YES, PALM'S ORGANIZERS ARE NICE machines ("You Can Take It with You," July 1999), but getting them to work with non-infrared-equipped Macs is a huge and costly pain. I'm surprised David Pogue didn't directly mention this. *Macworld* ought to let people know that the cost of attaching a Palm to a new G3 is not just \$6 for a serial cable but more like \$76, because a \$70 USB-to-serial adapter is required to connect the cable to the machine.

We already know that Apple has no interest in providing support for so-called outdated connectors. Apple's decision to decommission serial ports, SCSI ports, and floppy drives is a special kind of tyranny, one so poorly conceived that the folks in Redmond wouldn't even try it.

DAVID MENDONCA
Troy, New York

According to recent reports, 3Com/Palm Computing will release a USB cradle at some point, although no date has been set. In the meantime, we agree with David's point and advise you to factor in the extra cost if you're considering getting a Palm.—Ed.

Worth the Cost

NORMALLY I AGREE WITH *MACworld's* reviews, but not in the case of Newer Technology's BookEndz (*Reviews*, July 1999). I own one, and I am glad I do. I frequently take my PowerBook out of the office, and BookEndz makes everything so much easier—I turn off the machine, and I'm out of there. When I return, I pop the PowerBook back in place, and I'm ready to go to work. BookEndz has alleviated the problem of loose wires falling down behind my computer table, eliminating a lot of hassle. It also reduces the risk of bent connectors in the

plugs. True, the product may be pricey, but it is worth the investment for those of us who treat a PowerBook like the portable it is designed to be.

BOB WALL
Seattle, Washington

Invigorated!

DORI SMITH'S ARTICLE "INVIGORATE Your Site with JavaScript" (*Create*, July 1999) sure hit the spot! I've never needed, nor had any interest in getting into, any programming language, but I did want to get more interactivity in my Web pages. Tweaking Smith's script to work on my page gave me flashbacks of those old thrills I used to get from working on a HyperCard stack on my Mac. As part of the tweaking, I added 0.2 inch to the bottom of each image. I placed the title of the image in this space. This way you get the title of each image in the slide show. Now I have a whole new world to explore. Thanks.

HAROLD OLEJARZ
Tenafly, New Jersey

A Write-Protect Conspiracy

FINDING OUT THAT MICROSOFT has its own unique value system is a rite of passage for most computer professionals, not unlike your first, er, kiss (*The Desktop Critic*, July 1999). In my own case, I recall a client a few years back who called about installing Microsoft Word on a Macintosh with a suspect floppy drive. The drive could read just fine but was known to destroy data when used for writing. "No problem," I said, "simply set the write-protect tab on the installation disk, and you should be OK." Nope—Mr. Gates and Microsoft obviously didn't see it that way. During installation the software wrote registration information to the disk anyway, bypassing the tab and ultimately ruining the data. Silly me—after all, the tab was really only an industry convention. If you are bound and determined to ignore it, of course you can. That was some years ago. These days, it seems, Microsoft is ignoring a lot more than the write-protect tab on a floppy.

B. APPEL
Toronto, Ontario, Canada

continues

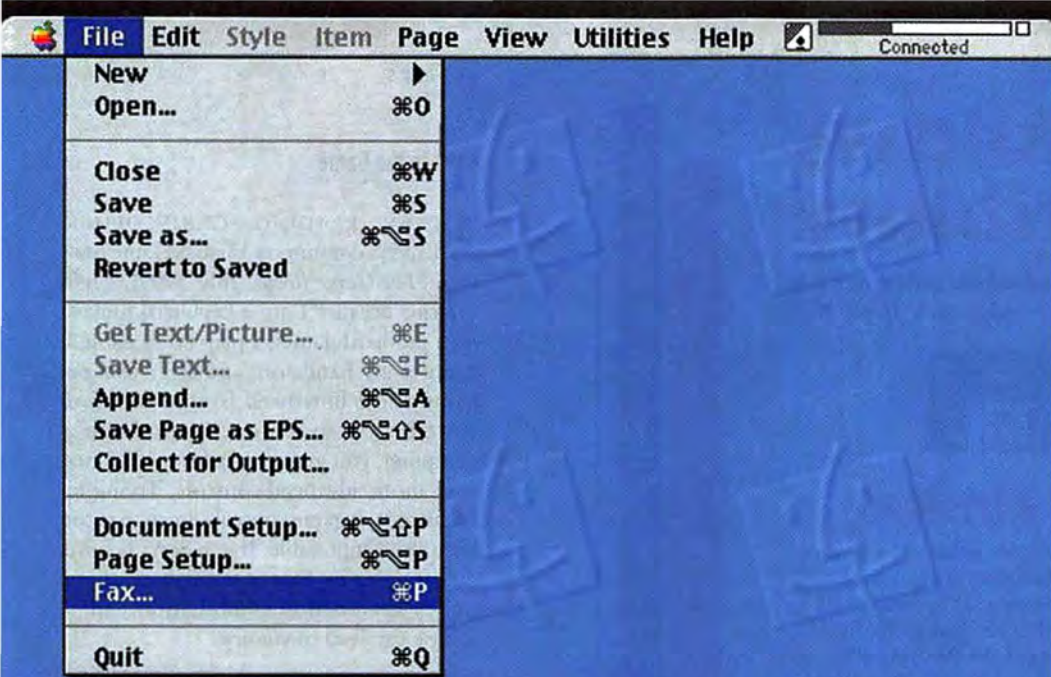

Only GlobalFax Faxes as Easily as Printing from Any Program on Your iMac or G3.

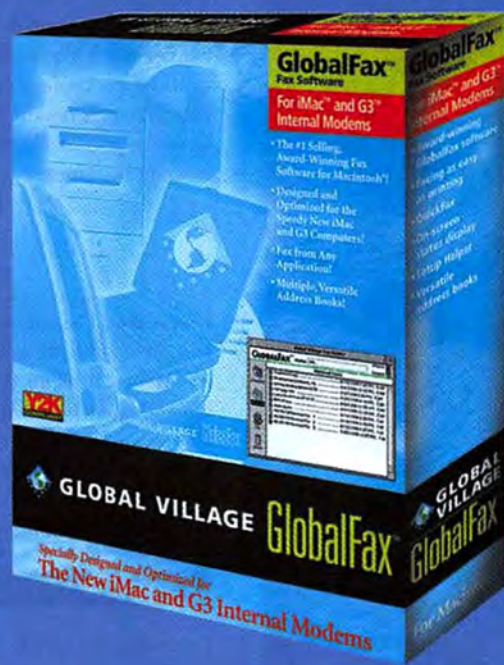

Stay Tuned!
Great **NEW** peripherals
on the way
this Fall!

- With GlobalFax™, you get all of these cool features:
- Fax, as easily as printing, directly from any application
 - Receive, view, print and manage faxes
 - On-screen call-status display
 - The exclusive QuickFax Fax Center
 - Multiple, versatile personal address books
 - GlobalFax is made exclusively for the internal modems in...



the iMac™...



the G3 desktop...



and the G3 PowerBook®.



www.globalvillage.com
(800) 336-2009

Macworld
EDITORS
CHOICE
★★★★

MacHome
READER'S
CHOICE
★★★★

Global Village®, winner of nine Macworld® Editors' Choice and MacHome Readers' Choice Awards.

"I've been a happy GlobalFax user for years. It's been indispensable for me."
-- Guy Kawasaki, CEO, garage.com
author of Rules for Revolutionaries and The Macintosh Way

Choose 106 at www.macworld.com/getinfo

Now available at Mac dealers nationwide.

COMPUSA
(800) 294-4727

MacConnection
(800) 800-0009

macZone
(888) 211-5032

MacWAREHOUSE
(800) 397-8508

MacMall
(800) 328-2790

Mac/Windows® Compatibility

The New OrangePC® 660/450MHz Windows® compatibility card is 10 times faster than VirtualPC® and tracks a real Pentium® III 450 MHz.



...No Speed Limits!

When you're tired of fooling around with other people's PCs, or some pokey PC software emulator, it's time to step up to a real Windows® compatibility card for your Mac – the Orange®PC. You know it's serious when the new OrangePC 450 MHz benchmarks side by side with a real Pentium® III; it's also 10 times faster than VirtualPC®.

And OrangePC is better than a PC clone anyway. OrangePC is seamlessly integrated into your Mac giving you a single platform footprint, live copy/paste between Mac/PC environments, shared files and shared peripherals. It's elegant; it's cool; it's just plain better! A 30 day money back guarantee is the same as a no risk test drive, without speed limits!



"19 Years of Innovation and Excellence"
(714) 779-2772 • www.orangemicro.com



Benchmark is a 3DMark 99 Max Synthetic CPU Speed run on a "Blue and White" G3 Power Macintosh G3/400.
*VirtualPC software emulator.

© Orange Micro, Inc. 1999

Keys to the Game

AFTER READING CHRISTOPHER Breen's column on Virtual Game Station (*The Game Room*, July 1999), I felt inferior because I am a keyboard junkie. As a die-hard gamer, I play every game I can get my hands on, and after using a game pad I borrowed from a friend, I vowed never to use one again. With a computer, you get more-advanced games with more-advanced controls. Trying to break today's game controls down to eight buttons is impossible. If you don't believe me, try playing *Starsiege: Tribes*, where only a keyboard in combination with a mouse can lead to victory.

ALEX MEASURES
Arlington, Massachusetts

Stretching the Metaphor

IF BILL GATES IS DARTH SIDIOUS and Microsoft is the evil empire, then we Mac users must be the Rebel Alliance. And that makes Steve Jobs, who? Obi-Wan?

Flash back to October 1997, when Steve Jobs said, "We have to let go of the notion that for Apple to win, Microsoft has to lose. The competition between Apple and Microsoft is over as far as I'm concerned." Microsoft then bought \$150 million in Apple stock. So maybe Steve Jobs is really Anakin Skywalker, and if you know your *Star Wars* episodes, you know who he becomes.

TOM ELESON
Sidney, Montana

Letters should be sent to *Letters*, Macworld, 301 Howard St., 16th Fl., San Francisco, CA 94105; via fax, 415/442-0766; or electronically, to letters@macworld.com. Include a return address and daytime phone number. Due to the high volume of mail received, we can't respond personally to each letter. We reserve the right to edit all letters. All published letters become the property of *Macworld*.

CORRECTIONS

Contrary to our statement in the sidebar "Speech Recognition Returns to the Mac" in "The Millennium Mac" (August 1999), *Dragon Systems' NaturallySpeaking* products range in price from \$60, for *Dragon NaturallySpeaking for Teens*, to \$1,000, for *Dragon NaturallySpeaking Legal Suite*. **m**

Best Product* ...

Best Price!
\$49.00

MW EDITORS' CHOICE

Grappler®

SCSI

Ideal for new G3 Power Macs

MacWorld Magazine's Editor's Choice award went to Orange Micro's Grappler SCSI Card for three major reasons: 1. "fastest in its class" 2. "least expensive card in its category" 3. "and the only one that was bootable". Available in Fast, Ultra, and Ultra Wide. Make Grappler SCSI your choice!

Orange Micro inc.
www.orangemicro.com

* August, 1999 Macworld Magazine. © Orange Micro, Inc. 1999

Choose 60 at www.macworld.com/getinfo

Get the Winning Edge.

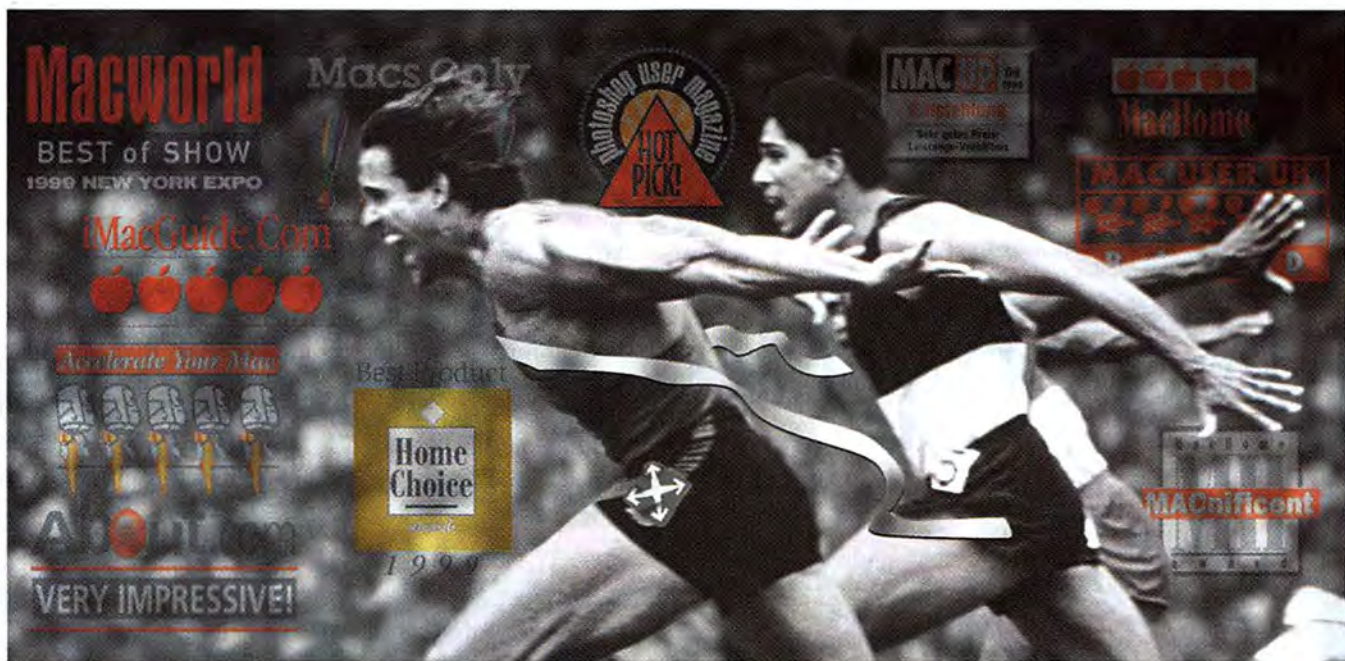

From QuickTime® video to break-neck speed, XLR8® products lead the pack in every category.

Right out of the gate, it may look like the field is full of speed and expansion options. Looks can be deceiving. When it's down to a photo finish, XLR8 products win the race.

We push the edge when it comes to innovation so you get the "best of the best" for your Mac®. That's why industry experts are awarding top honors to our patent-pending Carrier Upgrade Technology™ and InterView™ – the first USB product to turn the iMac into a true media machine. These products earn blue ribbon status by delivering the winner's edge, right out of the box.

XLR8, tools to perform and create... on your Mac.



MACb Carrier's patent-pending upgradeable upgrade technology was selected as Macworld's "Best of Show" and as Photoshop User's "Hot Pick."

"Buy it!" – MacFuture



InterView™ w/VideoShop 4.5 for USB and PCI has been listed as the perfect choice to deliver QuickTime video, and the "1999 Best Product of the Year" by Mac Home Journal.



888XLR8TOR • www.xlr8.com

Interex, Inc. • 8447 E. 35th St. N. • Wichita, KS 67226 • 316-636-5544 • 316-636-4639 fax

Other brand and product names are trademarks or registered trademarks of their respective holders. Product specifications subject to change without notice. ©1999 Interex, Inc.

Choose 59 at www.macworld.com/getinfo

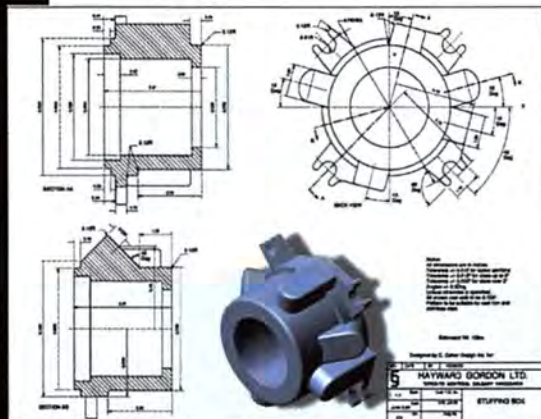

Carlos Cohen, C. Cohen Designs Inc., Toronto, Canada; Rendered with RenderWorks

Introducing VectorWorks The Next Generation of MiniCAD

Increased Productivity with Object-Based Design

VectorWorks' state of the art Object Technology helps streamline the design process by making it easy to create common design elements. Now, Objects like doors, windows, nuts and bolts, can be created and edited with a click of the mouse, making it easy to explore design alternatives, consider "what if" scenarios, and handle last-minute client changes.

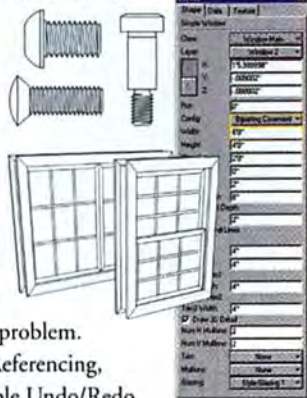

The Strength of a Proven CAD Technology

VectorWorks offers a solid foundation based on proven CAD technology—giving you the power and flexibility to tackle any design problem. New features such as Workgroup Referencing, DWG (v.14), Round Walls, Multiple Undo/Redo and an improved scripting language, strengthen VectorWorks' core CAD capabilities. And, with RenderWorks, VectorWorks' new photo-realistic rendering plug-in, you can bring your designs to life with textures, shadows and dramatic lighting.

The VectorWorks Advantage

With VectorWorks, you get it all—the flexibility and control of proven CAD technology and the productivity benefits of Object-Based design. VectorWorks ships FREE solutions for Architecture, Landscape Design, DTM and HVAC among others. Best of all, you aren't limited to the solutions we provide. VectorWorks is completely customizable, allowing you to create your own custom business solutions.

Special Offer to Readers of Macworld

Save \$279 by purchasing VectorWorks with photorealistic rendering direct for \$820 or, without rendering for only \$595. Includes FREE Tech Support and a 90-Day Money-Back Guarantee.



Diehl Graphsoft Inc
Software for Today's Professional
1-888-646-4223



Roberto Candusso, Arquitetos Associados, Sao Paulo, Brazil



The Vision Thing

by Andrew Gore

No Strings Attached

THINK THE iBOOK IS IMPRESSIVE? WAIT TILL YOU UNPLUG IT.

NEW YORK—ANOTHER Macworld Expo, another groundbreaking product announcement from Steve Jobs. Apple's performance at its major media events has become so predictably unpredictable that it's a wonder Steve doesn't just phone in the keynote from home.

The iMac, the blue-and-white Power Mac G3, and now the iBook—Apple just keeps knocking them over the fence. And while nothing is ever perfect, the iBook comes pretty darned close. It's relatively cheap and surprisingly fast, offers a good set of features, and has a beautiful design—at first glance, you immediately notice that it looks exactly like a portable iMac should. If ever a product was born to be a runaway best-seller, this is it. The only question that remains is, how will people get their data on and off their iBooks? And that's a debate we've all heard before, with the iMac.

iBook and Verse

To me, the biggest thing about the iBook announcement was not the iBook itself. Don't get me wrong—I'm not blasé about Apple's darling portable. (I hesitate to call the iBook *little*—it's actually larger and, at 6.6 pounds, heavier than the new bronze PowerBook G3.) The price—\$1,599—isn't rock-bottom, but it certainly is impressive given the power in this tangerine or blueberry package.

And while they're far from the iBook's top-level features, its little details make all the difference. For example, a spring-loaded handle lets you carry it easily; a latchless cover opens and closes like that of a jewelry case; and a power cord actually includes a cable wrap, so that you don't have to stuff a wadded-up ball of wire in your bag.

The iBook should especially appeal to students and anyone else who needs

an easy-to-use portable computer that doesn't cost an arm and a leg . . . and who appreciate style in their products. There's no doubt that the MTV generation will get the most out of this notebook's great mixture of style and substance.

But like I said, none of this covers the iBook's most important feature.

The Golden Age of Wireless

The most visible difference between the iBook and all other portable PCs is something as invisible as the air—AirPort, Apple's wireless networking product. Imagine, if you will, setting up a network that's as fast as (or even a tiny bit faster

house, use HomePNA (a networking system that piggybacks on your existing telephone wiring), or go wireless. Up until now, wireless networking has been far too expensive for most people and hasn't been particularly Mac-friendly. But the AirPort and its \$299 Ethernet-friendly base station change things—not just for the iBook, but for all Mac users.

Already Farallon has announced a \$299 wireless networking PC Card, compatible with the AirPort, that will give older PowerBooks the ability to roam freely at Ethernet speeds. And it's only a matter of time before other hardware appears that will let you connect deskbound computers in far-flung parts of your house without getting up close and personal with the fiberglass insulation in your ceiling.

iBook 'Em, Dan-o

Does the iBook rid the world of Ethernet? Probably not—Ethernet cables and hubs are cheap, and Ethernet ports are built into every Mac, including the iBook. But the iBook does usher in a world where wires are no longer mandatory—and where portable computers can roam free without giving up the Internet, one of the biggest reasons we use computers.

As more and more people attempt to bring their pre-Internet households into the networked age, and as more schools have students taking their computers with them to class, the importance of wireless networking will be paramount. And it looks like Apple's beaten everyone to the punch.

So where's the AirPort for my Power Mac? I've got computers to connect, and I don't think I can bear to use my crawl space now that I live in a world with the iBook in it. ■

Questions? Comments? E-mail them to Andy at visionthing@macworld.com.



than) 10BaseT networking without having to run any cables. Or even more impressive, imagine surfing the Net from your high-speed home DSL line while plucking cherries from the tree in the backyard. (Our tree turned in a bumper crop this year, so I spent a lot of time picking cherries this summer.)

If you're like me, you've got a house that's full of computers and full of computer users but only one connection to the Internet—in my case, DSL. Your options? Get down and dirty in your attic or crawl space running wires throughout your

**YOU SPENT
\$2 MILLION ON
THE LATEST
IS/IT SOLUTION.**

**FIND OUT IF
YOU'RE FIRED.**

All Network &
Communications

Telephony

WAN products

Bridges/routers/gateways

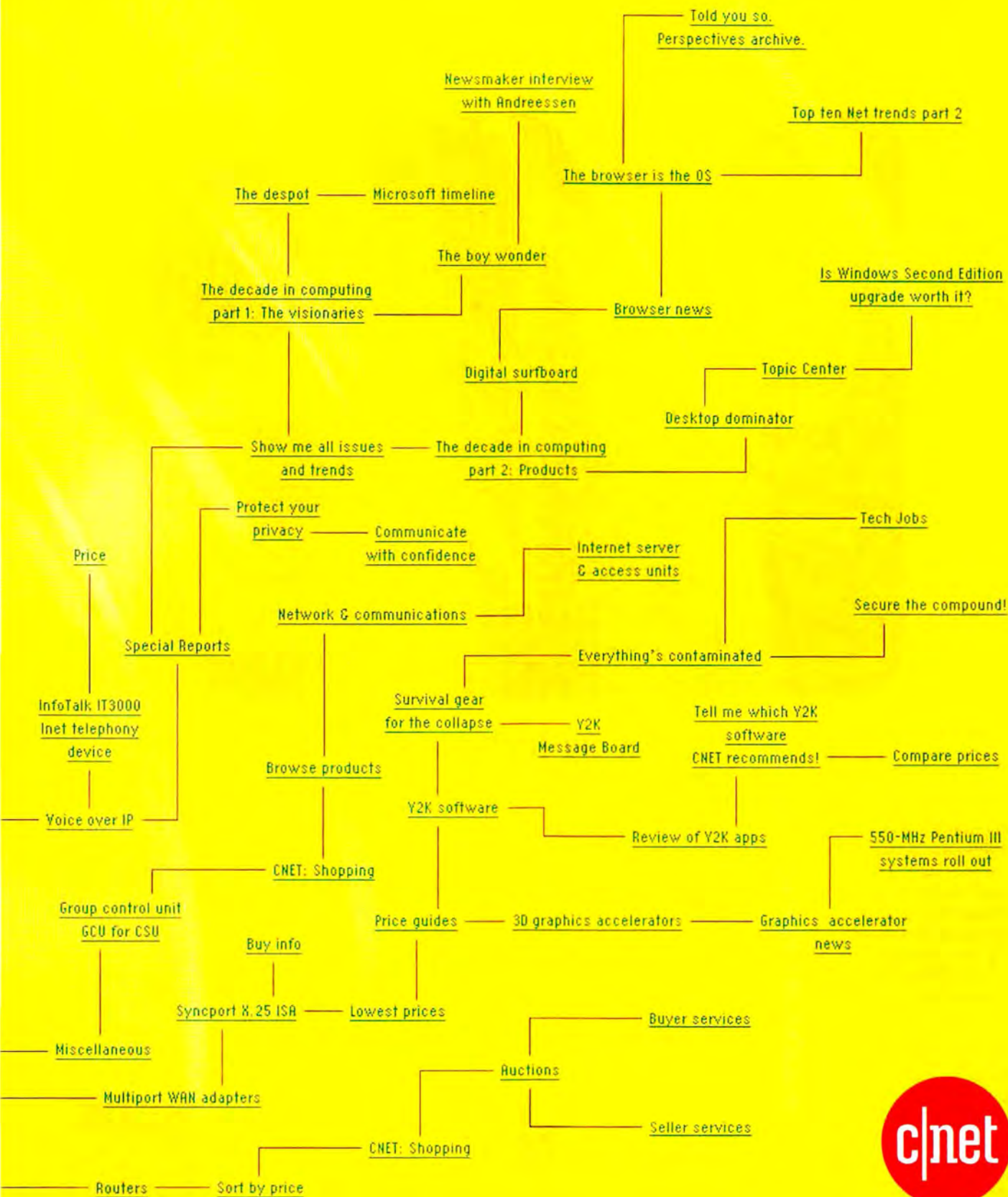

The source for computers and technology.™ CNET.com

There's only one utility in the world that does more for your Macintosh than TechTool Pro 2...

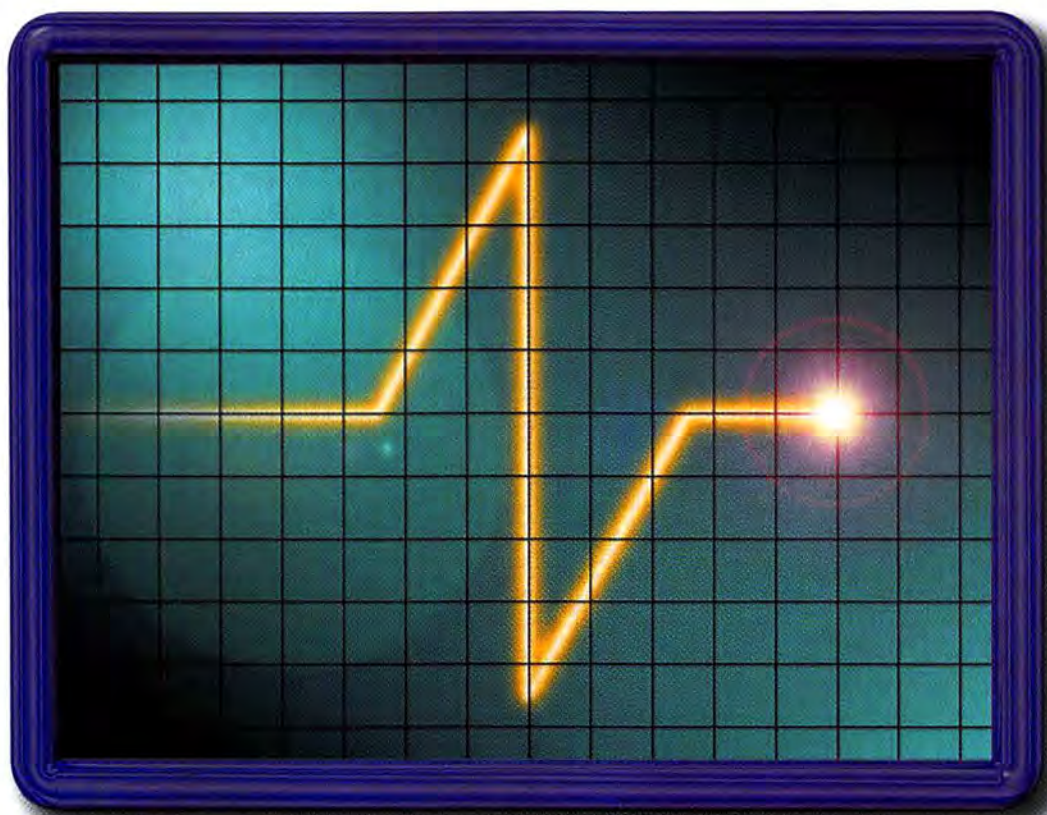

Introducing TechTool Pro 2.5

MicroMat's disk repair and Macintosh troubleshooting utility just became a whole lot better. Loaded with new features like Trash Cache™, which allows you to resurrect files you've accidentally deleted. Or our new Automated Diagnostic feature that checks your drives at the time intervals you specify, so you're always sure your drives are in top shape. TechTool Pro 2.5 even now supports new technologies like FireWire drives, USB floppy drives, System 8.6, all of the latest Macs and much more. But the real power of TechTool Pro 2.5 isn't in the features

you can see, it's in the features you can't see. Like a multitude of new drive repair routines that can save data that other utilities would simply abandon. An improved recovery system that will find lost files in the darkest caverns of a damaged drive. You'll also find improved performance on key features like disk optimization. But maybe the feature you'll find most interesting about this version is the price: FREE*. If you own any version of TechTool Pro 2, just go to our web site and grab the updater. You'll be glad you did.

MicroMat Inc.
800-829-6227
707-566-3831
FAX: 707-566-3871
info@micromat.com
www.micromat.com



Fix different.™



MacWorld
Aug. 1999



*Version 2.5 is available at no charge to registered TechTool Pro 2 users as an updater application directly from the MicroMat web site. If you do not wish to download the updater or would prefer a new CD, they can be purchased for \$25 plus tax, shipping and handling by calling the phone number above. Please have your serial number ready when calling. Prices subject to change without notice. ©1999 MicroMat Inc. All rights reserved. TechTool is a registered trademark of MicroMat Inc. Fix Different is a trademark of MicroMat Inc. Macintosh is a trademark of Apple Computer, Inc. Choose 67 at www.macworld.com/getinfo

online

Microsoft Preps Web-Software Upgrades

OUTLOOK EXPRESS

NOW TIES INTO MSN

HOTMAIL SERVICE

by Stephen Beale

Microsoft, speeding along in Internet time, is preparing to release upgrades to its flagship Web programs—Internet Explorer and Outlook Express—less than a year after the last major revisions of the software. Outlook Express 5.0, an upgrade to Microsoft's free e-mail client scheduled for release this fall, is further along in the development cycle, but the company is also previewing features slated for Internet Explorer 5.0. For iMac and iBook users, the company has announced a promotion in which it will offer a consumer edition of Microsoft Word 98 for \$99.

A New Outlook Major new features in Outlook Express 5.0 include an easy-to-use junk-mail filter, a new contacts database, built-in synchronization with 3Com's Palm Organizer, and a raft of interface improvements.

The new antispam filter applies a variety of algorithms designed to screen out unsolicited e-mail messages. Using a slider control, you can

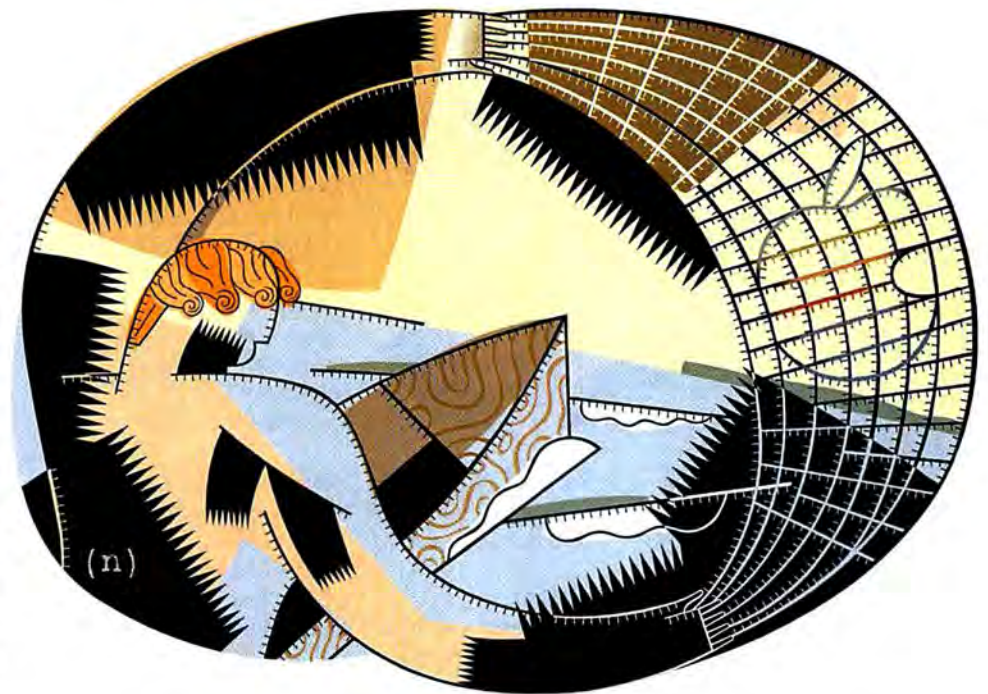

determine the filter's sensitivity: as you slide to the right, the filter screens out a higher number of messages.

Interface enhancements include the InfoBar, which lists other e-mail messages within the current message thread, and a new window for viewing attachments. New buttons in the preview pane let you increase the font size and apply AutoText cleanup, which rewraps text and corrects for common formatting problems. A new flag feature

lets you tag unread messages for later scrutiny.

The program's Address Book lets you define up to eight custom fields for each record, in addition to the standard name, address, and phone-number fields. As in version 4.5, you can use the Address Book to feed data to Word 98's mail merge feature.

When you create a new outgoing message, the new Address AutoComplete feature automatically displays a list of e-mail addresses from

the Address Book. As you type in letters, the list automatically updates to display records that match the character string.

A new Mailing List Manager lets you sort messages from specified addresses into user-defined folders. And you can schedule the program to download mail at certain times.

The upgrade also provides a direct tie-in with Microsoft's Hotmail, a free Web-based e-mail service. Instead of going to the Hotmail Web site to

continues

ONCE AGAIN, THE EDITORS OF *Macworld* have selected the hottest new products introduced at Macworld Expo. The awards are open to products announced at, or shortly before, the trade show. We also had to see the products in action, although some evaluations were based on prototypes or beta versions.

EPICTURE

BeatWare (650/556-7900, www.beatware.com) offers up a full-featured tool for creating Web graphics and animation.

IBOOK/AIRPORT

The new consumer laptop looks like another hit for Apple (800/795-1000, www.apple.com). And Apple's AirPort technology brings industry-standard wireless networking to the iBook at an affordable price.

LIVESTAGE 2.0

Totally Hip Software (604/685-6525, www.totallyhip.com) has improved the script-building capabilities of its QuickTime authoring program.

MACH CARRIER UPGRADE

This G3 accelerator from XLR8 (888/957-8867, www.xlr8.com) makes it easy to keep current

with processor upgrades by letting you replace the chip when faster versions are released.

MADDEN 2000 FOOTBALL

Aspyr Media (512/708-8100, www.aspyr.com) gives us the first team-sports game for the Mac. Hopefully others will follow.

MICROSOFT OUTLOOK EXPRESS 5.0

The latest version of the free Microsoft (425/882-8080, www.microsoft.com) e-mail client



offers an improved interface, an easy-to-use junk-mail filter, and direct access to Hotmail accounts.

MULTIPASS C635

The first multifunction peripheral for the Macintosh, the MultiPass C635, from Canon (800/652-

2666, www.usa.canon.com), combines printing, scanning, and stand-alone copying and faxing capabilities.

SKYLINE WIRELESS NETWORK CARD

This PC Card from Farallon Communications (510/346-8001, www.farallon.com) brings industry-standard wireless-networking capabilities to the PowerBook G3.

STUDIO ARTIST

This innovative "graphics synthesizer" from Synthetik Software (415/864-6582, www.synthetik.com) offers a new metaphor for painting software. With it, you can create your own paint tools by modifying any of 200 parameters.

RIO PMP 500

RioPort (408/325-7000, www.rioport.com) finally gives the Mac its due with the first Mac-compatible MP3 player.

SOUNDJAM MP

New from Casady & Greene (800/359-4920, www.casadyg.com), SoundJam is the first Mac software that encodes and plays back MP3 titles. It's bundled with the Rio PMP 500, but you can also use it without an MP3 player.

send or receive mail, you can access Hotmail accounts from within the e-mail client. However, the new junk-mail filter won't screen out messages sent to Hotmail accounts.

The Hotmail tie-in could be considered a bold—or perhaps arrogant—move, since the company is clearly using its Web software to give a competitive advantage to one of its Web properties. Microsoft's ability to leverage

its software assets was a central issue in the recent Justice Department antitrust case.

New Explorer Microsoft is providing only a few details about Internet Explorer 5.0. The upgrade will support the latest round of Web standards, including Cascading Style Sheets 2.0, and will rely exclusively on Apple's Macintosh Runtime for Java to interpret Java applets. Microsoft announced last year that

it would abandon its own Mac-based Java interpreter in favor of Apple's.

The software will also include the Auction Manager, which tracks transactions on eBay and other popular auction sites. Instead of going to the Web site to check new bids or the auction's closing time, you can instruct the browser to play a sound, display an alert, or send an e-mail message when activity occurs.

People running auction sites will probably have mixed feelings about this feature: it will make the sites easier to use but will also reduce traffic and, with it, ad revenue. (Microsoft does not have an auction site of its own.)

Consumer Word Along with the forthcoming Web software, Microsoft has announced a special promotion under which it will offer a consumer edition of Microsoft Word 98 for \$99 (\$129 with a \$30 rebate). Word 98 Special Edition for the iMac and iBook includes a full version of Word 98, along with clip art, greeting-card templates, and sample card paper. The software license specifies that the software can be run only on Apple's iMac and iBook, but no proof of purchase is required. It's a great deal, considering that Word 98 retails for \$249 and an upgrade from previous versions costs \$149. The promotion is good through January 31, 2000.

online

Get Ready for QuickTime TV

APPLE ANNOUNCES A
STREAMING-VIDEO
WEBCAST NETWORK

by Stephen Beale

Could a new media empire be brewing in Cupertino? At the recent Macworld Expo in New York, Apple announced QuickTime TV (QTV), a network that delivers live video and audio over the Internet. An extension of the streaming-video capabilities in QuickTime 4, QTV lets you tune into con-

tent from ABC News, Disney, BBC World, ESPN, HBO, and other well-known media outlets. Some content providers, such as HBO, are providing previews of movies and other attractions available through their premium services. Others, such as Fox News, provide live feeds of their cable broadcasts.

Mac and Windows users can access QTV channels by using the Favorites feature in the new QuickTime Player. For example, clicking on the BBC channel in the Favorites drawer brings up a BBC newscast.

Along with Apple's QuickTime software, the network also uses content-delivery technology from a Cambridge, Massachusetts-based company called Akamai, which maintains a global network of high-speed Web servers. By distributing audio and video streams through the Akamai network, Apple says it can dramatically speed the delivery of QTV content.

Media Mogul? So is Apple following Microsoft's footsteps and getting into the media business? Not exactly, says Apple Product Marketing VP Phil Schiller. Apple's goal, he says, is not to launch a new business venture but to promote QuickTime's streaming-video capabilities.

He also makes it clear that QTV won't compete with the broadcast and cable networks; after all, even the best-looking Web video can't match the quality and frame rate of broadcast video. However, thanks to QuickTime's scalability, he says, it will be easy for content providers to improve video quality as Internet bandwidth increases. With QuickTime 3, Apple introduced the ability to stream QuickTime movies at different data rates, depending on the speed of the user's Internet connection.



Solid-Ink Printer Gets iMac Look

IMAC-INSPIRED INDUSTRIAL DESIGNS ARE SHOWING up in all kinds of unexpected places. The latest company to jump on the blue-and-white bandwagon is Tektronix (800/835-9433, www.tek.com), which has released a new version of its Phaser 840 solid-ink printer. The Phaser 840 Designer Edition features a built-in 10/100BaseT Ethernet port and provides 1,000-dpi letter-size output at six pages per minute in standard-color mode.—MACWORLD STAFF

online

Personal-Info Managers Go Online

WEB SITES OFFER FREE PIM, E-MAIL SERVICES

by Macworld staff

Two Web sites are enticing Mac users with an array of free services, some of which duplicate features found in simple personal-information-management applications. Magically (www.magicaldesk.com) and Zcentral (www.zcentral.com) offer free Web-based e-mail, data storage, address books, multiuser calendars, and other services. Both let you exchange documents with other users by

placing files on FTP servers.

Magically, which offers 5MB of free storage space, provides access to its features through a customizable virtual desktop that includes links to Mac-related Web sites. You also get a Sherlock plug-in for searching e-mail messages and other content. The company earns revenue by offering premium services, such as a \$5-per-month MagicalViewer application that lets you view files in a wide variety of formats even if you don't have the host software. You can also pay for additional storage or e-mail accounts.

Zcentral, which earns revenue through advertising and cobranding deals, provides 20MB of free storage space and an address book that automatically updates itself if other registered users change their contact information. Mac Publishing, the publisher of *Macworld*, has signed an agreement to offer Zcentral's ser-

vices through Mac Publishing Web sites, which include Macworld Online, Macweek.com, Mac Central, iMacworld, and MacBuy.

publishing

More Pixels for New Kodak Cameras

NEW MODELS BREAK THE TWO-MEGAPIXEL BARRIER

by Macworld staff

Fast on the heels of archrivals Nikon and Olympus, Kodak (800/235-6325, www.kodak.com) has introduced three new digital cameras, including its first models to surpass a resolution of two megapixels.

Leading the new product line is the DC290, a \$1,099 point-and-shoot camera with a 2.1-megapixel CCD—capable of producing images at a resolution of up to 1,760 by 1,168 pixels. Other features include 3× optical zoom, external flash synchronization, audio recording and playback, and a single connection that serves as a serial or USB port. The camera stores images on a 20MB CompactFlash card. An accessory allows use of standard 37mm threaded lenses.

The camera uses the Flashpoint Digita operating environment, which includes a scripting language that lets you control image-capture functions. One script allows the camera to accept data from a global-positioning-satellite receiver. The camera, attached by a bracket to the receiver, automatically labels each shot with the time and location.

continues

Kodak sells a \$2,000 bundle that includes the camera, receiver, bracket, and cable.

The \$799 DC280 features the same 2.1-megapixel resolution as the DC290, but with a 2× optical zoom and no Digita software.

Kodak has also introduced the DC215, a compact \$399 camera with 2× optical zoom and a megapixel sensor capable of capturing images at 1,152-by-864-pixel resolution. The camera connects to serial ports (no USB) and stores images on a 4MB CompactFlash card. The \$499 gold version features an 8MB CompactFlash card and a USB CompactFlash reader.

Along with these new cameras, Kodak has also announced the DC240i, a version of its \$599 DC240 with an iMac-inspired industrial design. Kodak has not announced pricing for the iMac version.

Kodak will continue to sell its DC265, which features a 1.6-megapixel CCD, at a new price of \$899. However, the company has discontinued the DC210, DC220, and DC260.

graphics

MetaCreations on a Diet

DEVELOPER SELLS
CONSUMER-SOFTWARE
LINE TO SCANSOFT

by Stephen Beale

Just a few months after seeing the departure of Kai Krause, MetaCreations (805/566-6200, www.metacreations.com) has sold off three consumer programs that bore the flamboyant executive's name: Kai's Super Goo, Kai's Photo Soap, and

Kai's Power Show. ScanSoft (978/977-2000, www.scansoft.com) will add the programs to its line of text-recognition and digital-imaging software, which includes TextBridge Pro and PaperPort Deluxe. MetaCreations

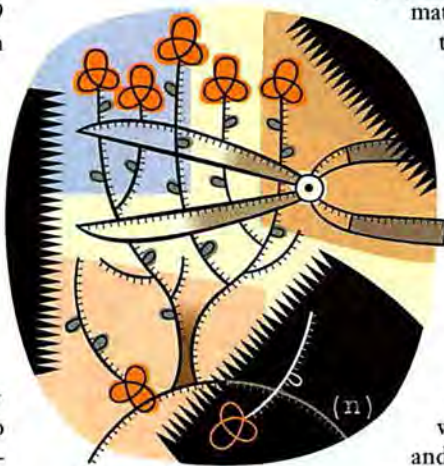

will handle support for the three consumer products through the end of the year.

ScanSoft says it paid \$2.6 million and assumed up to \$950,000 in liabilities to acquire the products. MetaCreations could earn up to \$1 million more in financial-performance-incentive payments. MetaCreations says there will be no layoffs as a result of the sale.

Time of Changes The sale of the three products is part of an ongoing transition for the software publisher, which has changed its tag line from "The Visual Computing Software Company" to "The Creative Web Company."

MetaCreations says that it will now focus on 2-D and 3-D applications for graphics professionals. The company recently released Canoma, a program for creating 3-D scenes from still photographs, and Poser 4, a new version of its 3-D character-animation software. MetaCreations has also begun selling individual Photoshop plug-ins through its Web site.

The company plans to release a patch later this year for its Bryce software that will let you incorporate animated Poser characters into Bryce landscapes. MetaCreations has also been demonstrating a forthcoming under-\$200 plug-in that will add automatic lip-syncing capabilities to Poser: when you play a voice track, the plug-in causes the character's mouth to move in a natural manner.

Informal Alliance The company is following the same path taken by Macromedia, which hit troubled financial waters two years ago and then underwent a transition in which it focused on Web authoring tools and shed such noncore products as Xres and Extreme 3D. Indeed, it appears that Macromedia has forged an informal alliance with MetaCreations, which had a major presence at the recent Macromedia User Conference. Despite their common focus on Web-graphics applications, there is almost no overlap between the companies' product lines. Macromedia CEO Rob Burgess and MetaCreations CEO Gary Lauer are both Silicon Graphics veterans.

MetaCreations has also announced MetaStream.com, a joint venture with Computer Associates aimed at promoting the former's MetaStream 3-D Web technology. The new venture, to be headquartered in New York City, will license MetaStream software for use in e-commerce applications and will also provide development services. Robert Rice, MetaCreations' former vice president of strategic affairs, will head the joint venture.

systems

IBM to Deliver Mac ViaVoice

BIG BLUE JOINS DRAGON SYSTEMS, MACSPEECH WITH SPEECH SOFTWARE

by Macworld staff

Mac-based speech-recognition technology has taken another leap forward with IBM's July announcement that it will offer a Mac version of its ViaVoice dictation software. IBM joins Dragon Systems and MacSpeech in announcing plans to deliver continuous-speech-recognition technology for the Mac (see the "Speech Recognition Returns to the Mac" sidebar in "The Millennium Mac," August 1999). IBM says it will release the software later this year.

IBM representatives demonstrated an early version of the speech-recognition program at Macworld Expo New York. Although the software will be based on IBM's current Windows offerings, an IBM spokesperson says the company has not yet decided on a price or on which specific features to include.

ViaVoice and Dragon's NaturallySpeaking both use continuous-speech-recognition technology. Older speech-recognition products required discrete pauses between words. Continuous-speech-recognition technology lets you speak in a more natural manner. Reviews of PC versions of the two packages have generally given the nod to NaturallySpeaking, citing its high recognition accuracy. MacSpeech, a new company, does not have a PC voice-recognition product.

 **TDK**®

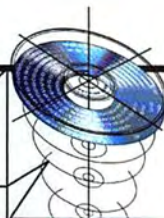

CD-R

ENTER www.tdk.com FOR CLEAR CD-R INSIGHT

EMBRACE **IsoPure** RECORDING TECHNOLOGY



evolve your music self.

©1999 TDK ELECTRONICS CORPORATION

Reviews

17-Inch CRT Monitors

IYAMA AND APPLE
DISPLAYS STAND OUT IN
MEDIocre BUNCH

THE BIG MONITORS USED BY graphics designers are great if you can afford them, but most of us need a more cost-effective way to get the job done. For most tasks—especially Web surfing, gaming, and general business applications—a 17-inch display fills the bill.

Macworld Lab put six 17-inch CRT monitors—Iiyama's Vision Master Pro 410, MGC Technologies' MGC-790, NEC Technologies' MultiSync E750, Optique's Optique V75, Philips Consumer Electronics' Philips 107MB, and ViewSonic's ViewSonic GF775—through their paces. The monitors, all priced under \$500, are designed for use at 1,024-by-768-pixel resolution, but they support higher resolutions as well.

We tested each monitor against our reference model, Apple's \$499 Studio Display (★★★★; *Reviews*, May 1999), paying particular attention to sharpness; color accuracy; and image quality at high resolution. Although most of the monitors offer acceptable quality, none matched the reference model.

Shadows and Slots

The Iiyama and Apple displays use aperture-grille technology, in which thin vertical wires direct electrons to the screen. The Philips, Optique, and MGC mon-

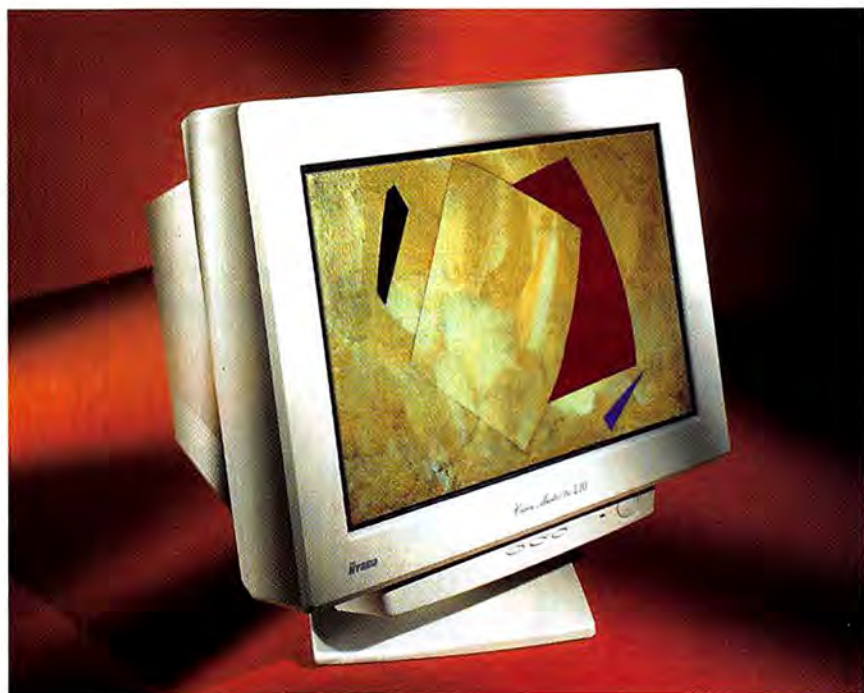

ARNOLD TOSEJO

itors use shadow-mask technology, in which closely grouped holes align the electrons. The ViewSonic and NEC displays employ a new technology called *slot mask*, in which electrons pass through rectangular or elliptical openings.

NEC claims that its ChromaClear slot-mask design, which uses elliptical holes, increases the range of colors a monitor can display. However, in our testing, the two aperture-grille monitors surpassed the slot- and shadow-mask tubes.

The Iiyama and ViewSonic monitors feature flat screens, which tend to

reduce glare and eliminate distortion at the display's edge. However, flat screens are not necessarily better than the curved ones found on most CRTs: the Iiyama display scored high marks for display quality, but the ViewSonic monitor failed to stand out from the pack.

A Sharper Image

If you plan to spend much of your time staring at words and/or numbers on screen, you'll want a monitor that's capable of displaying sharp text. To test sharpness, we opened a large Microsoft

REAL PRODUCTS
REAL RATINGS

Reviews you can trust: Macworld rates only final shipping products, not prototypes. What we review is what you can actually buy.

OUTSTANDING: ★★★★★

VERY GOOD: ★★★★

GOOD: ★★★

FLAWED: ★★

UNACCEPTABLE: ★

Excel spreadsheet with each display set to 1,024-by-768-pixel resolution. We viewed long columns of numbers, plus white text on a black background; the latter often reveals sharpness problems you won't notice with black text. To ensure consistency, we set each monitor's contrast to maximum and adjusted the brightness on a test image to create a dense black without loss of gray detail.

Of the six monitors we tested, only Iiyama's Vision Master Pro 410 scored a high sharpness rating. Thanks in part to the flat CRT, the numbers appeared extremely crisp all over the screen, including the corners, where you would expect any blurriness to be most evident.

Although none of the other displays exhibited outstanding sharpness, all of them were acceptable. However, the MGC-790 blurred reverse text and deformed numbers at the edge of the screen. Reverse text on the Philips monitor was also hard to read, mostly because the display was too bright.

These displays are best used at 1,024-by-768-pixel resolution, which assures that text and images are shown at their actual size. There may be occasions, however, when you'll want a higher resolution—even if it reduces 12-point type to the size of classified-ad copy.

To see how the monitors held up, we cranked the resolution of each to 1,600 by 1,200 pixels and viewed an image in Adobe Photoshop, paying particular attention to the program's palettes. Predictably, on-screen text at the higher resolution was difficult to read on all six displays. However, reading the palette names was especially tough on the MGC

and Philips monitors. The other four monitors' sharpness was acceptable—we had to squint a little, but we were able to navigate through the palettes.

Get the Color Right

Although none of these monitors are meant for color proofing or other high-end graphics work, you don't want to view a vacation photo and wonder why the Black Sea looks so red. To evaluate color accuracy, we viewed a Photoshop test image on each display at 1,024-by-768 resolution.

None of the monitors matched the color-reproduction capabilities of Apple's Studio Display. The MGC-790 was the most disappointing: a white background displayed as light blue, and blacks and browns were faded. The Optiquest and ViewSonic displays rendered reds with a bluish cast, and the ViewSonic also suffered from faded colors. Even the Iiyama monitor, which otherwise scored well in our tests, could not quite match the deep red hues of the Apple display.

The Philips and NEC monitors scored low marks on color reproduction, primarily because they're too bright. Generally, you want a monitor capable of high brightness levels to compensate for direct sunlight. However, both displays go too far in this respect. Even when we lowered the brightness setting, colors appeared washed-out. The other monitors have acceptable brightness levels.

All of the monitors we tested offer controls—buttons, wheels, or some combination thereof—that let you navigate through the on-screen menu system. You can use these controls to adjust brightness, contrast, scaling, horizontal and

vertical positioning, and other settings.

The MGC display uses a notched wheel, which we found works better than the ViewSonic and Philips monitors' smooth wheels. The notched wheel makes it easier to adjust settings in fixed increments; the smooth wheels tend to cause large jumps in values. The other displays use button controls.

When you're adjusting brightness or other settings, all the monitors display a bar that shows how much you've changed the value. However, the Optiquest, Philips, and MGC monitors also show numeric values, allowing for more-precise adjustments.

Being Macintosh-display workhorses, these 17-inch monitors don't offer many frills. None include USB hubs, and only the Philips monitor has built-in speakers. And because these monitors are sold to PC as well as Mac users, none feature a truly cutting-edge industrial design: it's boxiness and opaque beige all around.

Macworld's Buying Advice

Among the 17-inch monitors in this roundup, only Iiyama's \$469 Vision Master Pro 410 stands out as a top-notch display. It's reasonably priced and offers excellent sharpness and decent color reproduction. If price is your main concern, check out the Optiquest V75, which offers acceptable color and sharpness for less than \$400. However, your best bet remains our reference model, Apple's \$499 Studio Display; it offers the best sharpness and color reproduction, not to mention an iMac-inspired industrial design that will look right at home next to your blue-and-white Power Mac G3.—MICHAEL GOWAN

17-Inch Monitors Compared

Company	Product	Mouse Rating	List Price	Contact	Pros	Cons
Iiyama North America	Vision Master Pro 410	★★★★	\$469	800/394-4335 www.iiyama.com	Excellent sharpness.	Colors a bit faded.
MGC Technologies	MGC-790	★★½	\$349	877/428-9642 www.mgcusa.com	Least-expensive monitor in roundup.	Poor color accuracy; poor sharpness at high resolution.
NEC Technologies	MultiSync E750	★★★	\$449	800/632-4636 www.nectech.com	Acceptable sharpness.	Extreme brightness reduces color accuracy.
Optiquest	Optiquest V75	★★★½	\$399	800/843-6784 www.optiquest.com	Good price; acceptable sharpness.	Colors appear faded.
Philips Consumer Electronics	Philips 107MB	★★★	\$419	800/531-0039 www.philipsmonitors.com	Acceptable sharpness; includes speakers.	Extreme brightness reduces color accuracy; poor sharpness at high resolution.
ViewSonic	ViewSonic GF775	★★★	\$475	800/888-8583 www.viewsonic.com	Acceptable sharpness.	Colors appear faded.

QuickTime 4 Pro

MULTIMEDIA SOFTWARE ADDS TRUE STREAMING AND A GIMMICKY PLAYER

TWO STEPS FORWARD, ONE STEP back—that about sums up version 4 of QuickTime, the system software that enables Macs and Windows computers to work with dynamic media such as audio, video, and virtual-reality panoramas. The new version brings significant improvements in almost every area: it's easier to download, adds support for MP3 audio files and Macromedia Flash animations, offers smoother panning and sharper display of panoramas, and supports streaming—the ability to play QuickTime content as it downloads. Unfortunately, QuickTime 4's appeal is diminished by the gaudy, cumbersome interface of QuickTime Player, the bundled program most people will use to play back QuickTime content.

As it did with version 3, Apple distributes two flavors of QuickTime 4. We tested the \$30 QuickTime 4 Pro, which adds authoring features that let you convert from one format to another, perform basic editing, and save downloaded QuickTime movies to your hard disk. A free version that handles playback only is also available.

Installation à la Carte

QuickTime was putting on more weight with each new version, and version 3's installation program weighed in at more than 7MB. To ease QuickTime 4's download burden, Apple added a new installation program that lets you download just the QuickTime components you need.

At a relatively svelte 400K, the installer downloads quickly. The minimal installation is roughly 2MB and handles most QuickTime media (but, alas, not QuickTime VR). If you need additional features, the QuickTime Updater utility will grab the new components. Select everything, and you're back to a 7MB download. Thankfully, QuickTime 4 should be available on CD-ROM by the time you read this; pricing hadn't been announced at press time.

Into the Stream

With version 4, QuickTime joins RealNetworks' RealSystem G2 and Microsoft's Windows Media Technologies in

providing true streaming—the ability to broadcast live events or radio and TV feeds over the Internet or intranets, along with the ability to stream on-demand movies more reliably than with previous versions. But QuickTime streaming is new, and there isn't all that much to listen to or watch just yet.

From a media producer's standpoint, QuickTime has some advantages over the aforementioned competitors when it comes



The Player That Shagged Me QuickTime 4 Pro's QuickTime Player may look cool at first glance, but its volume control, Favorites drawer, and other features are a user-interface nightmare.

to streaming. But it also falls short, particularly compared to RealSystem G2. For example, although QuickTime 4 streaming lets you support multiple connection speeds, doing so is far more difficult than with RealSystem G2. (For details on producing QuickTime streaming content, see "Master Streaming with QuickTime 4," *Create*, in this issue.)

In promoting QuickTime streaming, Apple's Web site says that "unlike competing products, QuickTime streaming requires no per-stream charge." That claim is aimed directly at RealNetworks,

which prices its server software based on how many simultaneous streams you want to deliver. For example, a 40-stream RealSystem G2 server costs \$695. From there, prices quickly skyrocket into the four-figure range. Apple's QuickTime Streaming Server, by comparison, is included with Mac OS X Server and can dish out up to 2,000 simultaneous streams.

Still, Apple's claim is only partially true: RealNetworks does offer a free version of its RealSystem G2 server that supports 20 simultaneous streams—fine for a low-budget operation. RealNetworks' servers also have much lighter hardware requirements than Mac OS X Server's.

Not So Groovy, Baby

Most users will play streaming QuickTime content with the new QuickTime Player, which replaces the venerable MoviePlayer program that accompanied previous QuickTime versions. QuickTime Player adds some welcome improvements, including bass and treble controls for tweaking the sound quality to your taste. It can also play MP3 audio files, although it doesn't support playlists and can't play back files compressed with variable-bit-rate encoding.

MoviePlayer was an austere affair, but QuickTime Player wouldn't look out of place in Austin Powers's pad. A brushed-aluminum look evokes a sixties hi-fi set, but the bright finish makes small movies appear too dark. Worse, the new Favorites "drawer," which lets you bookmark movies and streams, is poorly designed.

Macworld's Buying Advice

QuickTime Player is an interface-design disaster, but the QuickTime 4 foundation upon which it rests is rock-solid. If you use QuickTime extensively, by all means upgrade to QuickTime 4 Pro. (If you do video production, though, verify compatibility with your software and hardware first.) If you only occasionally visit Web sites containing QuickTime content, you might find that the free QuickTime 4 is all you need.—JIM HEID

RATING: **PROS:** Extremely versatile; supports true streaming. **CONS:** Poorly designed player; can't play variable-bit-rate MP3s. **COMPANY:** Apple Computer (800/795-1000, www.apple.com). **LIST PRICE:** \$30.

Flash 4

WEB ANIMATION LEADER ADDS MP3 SUPPORT, SCRIPTING TOOLS

AS VENDORS RUSH TO ESTABLISH standards for Web-based media such as video and audio, one program has emerged as something of a standard for Web animation. Macromedia's Flash has quickly become the dominant tool for creating animation and simple interactivity, offering easy-to-use development tools and low-bandwidth animation files. And with this latest version, Macromedia has added even more reasons to adopt Flash technology: streaming-MP3 support, new actions, and improved development tools make Flash 4 ideal for Web designers who want to jazz up their sites with animations but who don't necessarily have Java-scripting skills.

Vectors in Motion

With Flash, you can create compact, streaming Web animations that are easily viewable on just about any platform. Because the program is vector-based, its animation files are very small and make for quick downloads. The Flash player takes care of rendering the vectors into bitmaps—complete with smooth, antialiased edges—and displaying them on screen.

Experienced users will notice a wealth of changes in Flash's interface, ranging from a redesigned Timeline window to improved drawing tools. For example, Flash's vector tools eschew the complicated control handles and points of illustration packages such as Macromedia FreeHand and Adobe Illustrator; instead, users can reshape an object simply by dragging its edges. It also adds several tools that experienced illustrators have come to expect, such as round-cornered rectangles.

The drawing interface benefits from long-overdue improvements such as default shift-selection of multiple objects and streamlined tool palettes, and the Inspector palette has been revamped with tabbed subdivisions containing multiple inspectors (see "Flashy Interface"). Curiously, flip controls aren't included in the Transform palette. We'd also like to see the addition of mirror transformations.

Flash's Timeline interface has undergone several improvements that make

animation scripting easier. The window itself has been redesigned and features new toggles, including switches for locking and hiding objects. Although the process of creating an animation remains largely the same, Flash 4 adds Guide Layers that let you script an object's animation by drawing a path along which it moves.

The new animation tools are as powerful and easy to use as ever, but velocity



Flashy Interface Flash 4's interface sports numerous changes, including a new tabbed Inspector palette.

controls would be a nice addition. Although the program retains version 3's ease-in/ease-out feature, it's not always possible to synchronize complex motions with audio or to tightly choreograph multiple complex motions.

Control Freaks

Flash 4 sports numerous new actions and tools that make it easier to create interfaces and add interactivity without resorting to JavaScript. For example, the new text-field tool lets you place an editable text field anywhere in your animation. The Text Field Properties dialog box lets you define properties of your fields, such as borders, background colors, length restrictions, and more. Associated with every editable text field is a variable containing the value currently entered in the field; you can pass variables between Flash movies and CGI scripts, using Flash 4's new actions.

Among the new actions in Flash 4 are IF/ELSE commands that let you create

conditional structures. The new LOOP command lets you create simple WHILE loops, and the new CALL statement lets you branch to a particular frame's actions, just as you would branch to a subroutine in a mainstream programming language.

Flash 4's new actions also let you create forms, dialog boxes, and pop-up menus. Forms can include standard interface elements, such as radio buttons and checklists, and can return data to the Flash player or to Web-based applications. Like all of Flash's other features, these interface elements are platform- and player-independent.

Interface elements are easy to implement with the new version's handy, powerful scripting actions. But although those elements offer a simple way to gather and post data, Flash 4 is short on "building blocks" for creating more-sophisticated custom interfaces.

Flash 3's audio support was good, but that of version 4—with its MP3 compression—is better. MP3 compression makes adding streaming audio to your Flash animations much more practical. In previous versions, you had to use audio very judiciously so as not to slow throughput. With version 4, not only can you attach small audio files to events such as button clicks but it's even practical to add long voice-overs and music beds under the audio. And each audio file in your Flash presentation's library can have separate audio settings, so you can tweak the compression, depending on the particular sounds.

Macworld's Buying Advice

Flash 4 is a must-have upgrade for any Flash user. The program's interface improvements streamline development, and the new scripting controls let you create much more sophisticated presentations. For animated Web sites, Macromedia has defined the standard.—BEN LONG

RATING: **PROS:** New scripting actions; streaming-MP3 support. **CONS:** Drawing tools still playing catch-up; no velocity controls for animation. **COMPANY:** Macromedia (800/457-1774, www.macromedia.com). **COMPANY'S ESTIMATED PRICE:** \$299.

USB 56K Modems

EXTERNAL MODEMS ARE EASY TO SET UP AND USE

MOST CONFIGURATIONS OF Apple's Power Mac G3 suffer from a common malady: the lack of a built-in modem. Because those systems also lack a traditional serial port, you can't simply plug in your existing serial-port modem. A slew of vendors have come to the rescue with USB modems that not only solve the missing-modem problem but also

two telephone ports, one for the line from the wall and one for a phone, fax machine, or answering device; a single USB cable connects the modem to a USB hub or directly to a Mac USB port. The units vary in size, with Boca's TelePort being the smallest overall. Viking's device stands vertically and is easily twice the size of the others (perhaps because it displays eight status lights, invaluable for troubleshooting).

You'll find the software easy to install from a CD for any of the units. The installers also load the accompanying fax software: Best Data bundles STF Technologies' Faxstf 3.2; Boca, its excellent Global-Fax 2.6.5; and Diamond, its own Faxcilitate 2.5.2. All these packages work well, although GlobalFax has the most convenient Macintosh user interface. Alas, none of the fax programs support OCR, once a standard feature with bundled fax software. The Viking

ships with Smith Micro's MacComCenter 1.3, an outdated, feature-poor package that periodically crashed our test Macs.

Test Flight

In online tests with several ISPs, the modems all performed well, managing connection speeds of up to 53 Kbps and hitting 200-Kbps throughput on highly compressed data. When products such as these perform almost identically, tech support is a critical distinguishing characteristic.

To test technical support, we asked each vendor to solve a problem involving its modem connected to an iMac. Boca's tech support was extremely helpful and gave us the solution we were looking for—we needed to install an iMac firmware upgrade from Apple. Diamond's tech support went one better, diagnosing the problem correctly and pointing out that the necessary firmware upgrade was included on the SupraExpress's CD. Both Boca and Diamond offer Mac-specific support resources on their Web sites.

Best's phone-support technicians

couldn't diagnose the problem; they acknowledged that they didn't understand how Macintosh models differed from each other. Viking simply said that its modem wasn't compatible with the iMac, even though it ended up working after we installed the firmware upgrade. And the two companies' Web support is minimal, limited to marketing information.

Macworld's Buying Advice

External USB modems make Internet and fax connectivity easier than ever. If your fax use is limited, save money by going with the bargain-priced Best Data Smart One or Diamond SupraExpress. If you're a faxing fiend, go for Boca Research's TelePort, with its first-rate fax software. Whether or not you're a frequent faxer, we can't recommend Viking Components' modem; its buggy software and poor Mac support aren't worth its higher-than-average price.—MEL BECKMAN

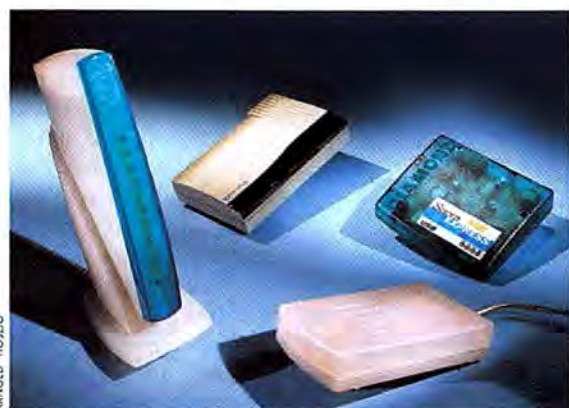

Clockwise from left: Viking's Viking 56K, Best Data's Smart One, Diamond's SupraExpress, and Boca's TelePort.

have some advantages over older serial-port modems: they get their power from the USB port rather than from a clunky external power brick, so they're easy to install and help reduce desktop clutter. And because USB's data rate is 12 Mbps, USB modems allow higher throughput (up to 200 Kbps) with data compression than do serial-port modems, with their speed limit of 115 Kbps.

All the modems we tested—Best Data's Smart One USB 56K, Boca Research's TelePort USB 56K, Diamond Multimedia's SupraExpress 56 USB, and Viking Components' Viking 56K USB—work with G3 Macs and support the latest V.90 56K standard, making them compatible with virtually all 56K Internet services. Where they differ is in their packaging, software, and support.

Package Deal

Each of the modems we tested comes bundled with a quick-start guide and a CD-ROM containing software and additional documentation. Each modem has

Smart One USB 56K

RATING: **PROS:** Easy installation; inexpensive. **CONS:** Weak tech support; fax software lacks OCR capability. **COMPANY:** Best Data (818/773-9600, www.bestdata.com). **COMPANY'S ESTIMATED PRICE:** \$100.

SupraExpress 56 USB

RATING: **PROS:** Easy installation; includes iMac firmware updater; good fax software; inexpensive. **CONS:** Fax software lacks OCR capability. **COMPANY:** Diamond Multimedia (800/468-5846, www.diamondmm.com). **COMPANY'S ESTIMATED PRICE:** \$100.

TelePort USB 56K

RATING: **PROS:** Easy installation; excellent fax software. **CONS:** Fax software lacks OCR capability. **COMPANY:** Boca Research (800/336-2009, www.globalvillage.com). **COMPANY'S ESTIMATED PRICE:** \$139.

Viking 56K USB

RATING: **PROS:** Easy installation; detailed status lights. **CONS:** Abysmal fax software; weak tech support. **COMPANY:** Viking Components (800/338-2361, www.vikingcomponents.com). **COMPANY'S ESTIMATED PRICE:** \$120.

We move the information that moves your world.™

adaptec®

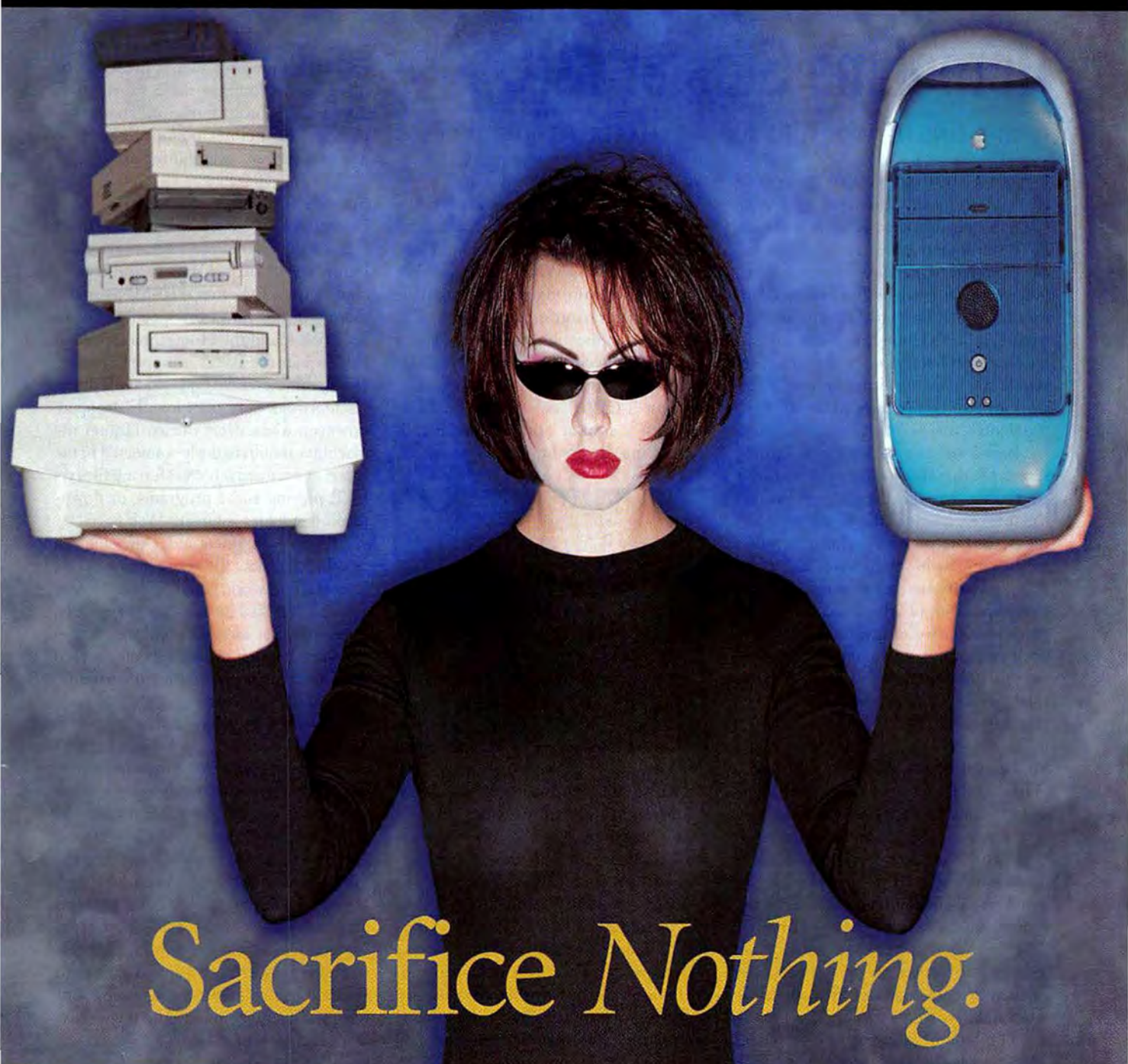

Sacrifice Nothing.



Go ahead, upgrade to that new G3 without sacrificing the SCSI peripherals you depend on. And in case you didn't know, Adaptec® SCSI cards support Apple's old SCSI Manager and newer SCSI Manager 4.3 devices so you can connect to whatever SCSI peripheral you might be using. But it gets even better. Adaptec SCSI significantly outperforms Apple's previous built-in SCSI, enabling your Jaz, scanner, and other peripherals to operate at peak performance. So if you want to upgrade to a new blue G3 without sacrificing anything, get an Adaptec SCSI card. For more information visit www.adaptec.com/mac.

© 1999 Adaptec, Inc. All rights reserved. Adaptec, the Adaptec logo, the Adaptec tagline, and PowerDomain are trademarks of Adaptec, Inc., which may be registered in some jurisdictions. Apple and Mac are registered trademarks of Apple Computer, Inc., used under license. All other trademarks are property of their respective holders.

HomeLine Starter Kit

PHONE-LINE NETWORKING BUNDLE SHARES INTERNET ACCESS

FOR THOSE WHOSE SKILLS don't include pulling wire, creating a network of home computers can be something of a challenge. And if you want to outfit each computer with a modem and an Internet connection, it can be a costly proposition as well. Farallon's HomeLine Starter Kit, a hardware-and-software combo that uses standard telephone wiring to form a network of two computers, addresses both problems—to a point.

Based on the HomePNA cabling standard, the HomeLine isn't the only phone-line-based networking product on the market, but it is the first to support the Mac. The package includes two PCI cards, compatible with Macs as well as PCs, and software that lets you configure one computer (a Mac) as an Internet gateway. Once you install the cards in both computers and connect standard four-pair phone cable to a phone line via existing RJ-11 wall jacks, you've got yourself a network.

Share and Share Alike

With the HomeLine, Macs and Windows 95 and 98 machines can share files, printers, and a single Internet connection. The HomeLine supports phone-based (modem and ISDN) and network-based (cable-modem and LAN) Internet connections; whenever a browser or other TCP/IP-based application is launched from any computer on the network, the gateway machine connects to your ISP as it normally would.

The HomeLine allows PCs to share resources with Macs, using AppleTalk (provided you install the bundled copy of Miramar Systems' PC MacLAN on the PC). And if you have Netopia's Timbuktu Pro, you can use any machine on the network to exchange files and messages or control a remote computer. An added bonus: if you currently dial up the Internet *and* connect to a local PC via the same network and you install the HomeLine on both machines, you won't have to switch TCP/IP configurations or add a second Ethernet connection just to grab a file from the Windows machine or surf the Web.

Troublesome TCP/IP

We installed HomeLine cards in a Power Computing Power Macintosh running Mac OS 8.6 and in a Dell OptiPlex GXa running Windows 95 and then followed the thin manual's installation and configuration instructions. The autoseup application configures a new Internet connection on the gateway Mac or creates a custom configuration, using existing TCP/IP and Remote Access settings; a similar application installs HomeLine drivers on PC clients.



ARNOLD TOEBO

Although setup on both machines was straightforward, we were initially unable to connect to the Internet from our PC client and we had only intermittent success surfing the Web from the PC after manually connecting to our ISP from the gateway Mac (rather than simply launching a browser). To make matters worse, Farallon's technical support wasn't much help: the first technician we spoke to was almost completely uninformed about the networking details of the HomeLine, and the second—who seemed to be reading from the user manual—ultimately concluded that the fault lay with our ISP. We fared no better when attempting to connect through a second ISP.

We finally abandoned the by-the-book approach most home users would take and dove into the networking nether regions of Windows. After changing the static IP address the HomeLine assigned to the PC, we entered the Mac's gateway address and our ISP's DNS address in the Windows 95 Networking control panel. Our efforts were rewarded with a

stable Internet connection, but the typical HomeLine user would probably be ill-equipped to make these substantive, nonintuitive configuration changes—changes that neither the documentation nor tech support even hinted at.

Speedy Sharing

HomePNA-based networks, such as those that use the HomeLine, operate at a maximum speed of 1 Mbps—significantly slower than Ethernet's 10-Mbps maximum but four times the speed of LocalTalk. We found the HomeLine's speed to be adequate for Web surfing, file sharing, and streaming-audio and -video playback. Connections were occasionally dropped, however, when users of two HomeLine machines simultaneously connected to the Internet were actively transferring files via FTP, playing audio programs, or downloading graphics-intensive Web pages.

If you've strained under the sluggish printing and slow file-transfer speeds of a LocalTalk network, you'll find the HomeLine's local sharing downright speedy. Even Ethernet users will find the HomeLine fast enough to share a color screen via Timbuktu or print a long document.

Macworld's Buying Advice

At \$139, the HomeLine Starter Kit isn't the cheapest product for creating a network, but it might be the most convenient (once you get it going). Families and SOHO users who want to share both local and Internet resources will appreciate the HomeLine's flexibility and relative speed. If your machines already have modems attached, Ethernet may make more sense for local file sharing and printing, and networking novices may want to wait until Farallon revises its autoconfiguration software and documentation. And if your network includes an iMac or a PowerBook, stay tuned; Farallon says a HomeLine product that supports these systems may be available later this year.—SHELLY BRISBIN

RATING:  **PROS:** Provides easiest way to share an Internet connection in a cross-platform environment; offers local and dial-up TCP/IP access on a single network. **CONS:** Impossible to configure with autoinstall procedure; pricey if you don't need all its features; no iMac support. **COMPANY:** Farallon Communications (510/346-8000, www.farallon.com). **COMPANY'S ESTIMATED PRICE:** \$139.

Powerful, fast, smart— and bred for the unbridled imagination.

(No, we're talking about the Intuos graphics tablet system.)



Now in USB!

Give your imagination full rein with the award-winning Intuos™ graphic tablet system from Wacom. With Intuos, you can sketch, paint and retouch images with natural ease and zen-like control.

Intuos, the #1 choice of illustrators, designers and photographers worldwide, features 1,024 levels of pen pressure-sensitivity. Its ergonomic design is unmatched and a pure joy for designers who demand top performance and productivity from all their graphic software. You can even add the cordless 4D Mouse or the new Intuos Airbrush for a truly customized digital toolkit.

Or choose **Graphire™**, Wacom's new pen and mouse set. Its small footprint, performance features and sub-\$100 price make it a great choice for those just getting started in digital art.

Intuos and Graphire... turn your imagination loose.

WACOM

800.922.2585 or www.wacom.com/imaginat5



Only \$99⁹⁵



©1999 Wacom Technology Corporation. Wacom is a registered trademark and Graphire and Intuos are trademarks of Wacom Company Ltd. All rights reserved. Artwork created by Phil Howe of Seattle, WA with a Intuos 9x12 graphics tablet. Wacom products are available at www.wacom.com, CompUSA, Microcenter and other fine retail and mail order resellers nationwide. Includes **Wacom Painter Classic**. Unbridled beast not included.

Choose 84 at www.macworld.com/getinfo

MacDrive 98 3.0

DISK-MOUNTER GAP NARROWS

APPLE'S 1998 INTRODUCTION OF the Mac OS Extended Format, also known as HFS+, created a scramble among developers of disk utilities as they prepared upgrades to support the new format, which increases a drive's effective capacity by reorganizing the way files are stored. Among vendors of disk-mounting utilities for Microsoft Windows, DataViz introduced HFS+ support in MacOpener 4.0 (★★★★½; \$60 list price; *Reviews*, January 1999). Now Media4 Productions has



Is It Mac or PC? With MacDrive 98, you'll quickly forget whether you're using Mac or PC media in your Windows PC.

closed the gap by adding HFS+ support to MacDrive 98 3.0, the latest version of its disk-mounting software. Either program is an excellent choice if you want to use Mac media with a Windows PC.

Nearly Identical

Except for adding HFS+ support, MacDrive 98 3.0 is identical to version 2.0. With it, you can use Macintosh disks on a Windows 95, 98, or NT 4.0 PC. The program handles floppies, Iomega Zip and Jaz cartridges, CDs, external hard disks, or any other disks available in a PC version. You can read and write data to the disks as if they're Windows media. With HFS+ support, the program can now handle media in the new disk format as well as the older HFS format.

The program remains an install-and-forget-it utility. Without using any special commands, you can access Mac disks from the Windows desktop, in Windows Explorer, and from Open and Save dialog boxes in Windows applications. The only time you'll even remember you're work-

ing with Mac media is when you see the apple that MacDrive 98 adds to disk icons. However, when you right-click on the disk icon to bring up Windows' contextual menu, the utility adds Macintosh-specific media options, such as the ability to format a disk for the Mac.

A Few Extras

Although it's similar to MacOpener, MacDrive 98 offers a few extra utilities that its rival does not. For example, it can identify the creator and file types of Mac files—handy when you're trying to update extension maps in Mac-disk-mounting software, in cross-platform networking software, or in Mac OS File Exchange. Another handy utility lets you copy Mac disks from your PC's drives. On Media4's Web site, you'll find several other utilities that remap special symbols between Mac and PC files so they'll appear correctly when you open a document.

MacDrive 98 doesn't work with Windows 3.1, but neither does MacOpener, which previously supported the older Windows version. DataViz dropped Windows 3.1 support in MacOpener 4.1, a recent update. (MacOpener 4.1 is also included with DataViz's ★★★★ \$100 Conversions Plus 4.6 cross-platform file-translation utility.)

Macworld's Buying Advice

Both MacOpener 4.1 and MacDrive 98 3.0 let you easily and transparently open Macintosh files on Windows PCs. MacOpener once had an edge because of its HFS+ support, but it's now almost impossible to choose between the two. Their prices are almost the same, and their key features are the same.

Nevertheless, we prefer MacDrive. It has a few niceties that MacOpener does not, allowing you to map file-name extensions more easily and providing the handy iconic reminder when you're working with Mac media. Most people probably won't use these extra features, but it's nice to have the added capabilities if you need them.—GALEN GRUMAN

RATING: ★★★★½ **PROS:** Mac disks are seamlessly accessible to PC users; easy to add file-extension maps; easy to format Mac disks on a PC. **CONS:** None significant. **COMPANY:** Media4 Productions (515/225-7409, www.media4.com). **COMPANY'S ESTIMATED PRICE:** \$70.

Great Tools.

Great Toolchest.

ACTION Utilities

The official successor to Power Utilities

The Most Powerful Macintosh Enhancements You Can Buy!

The Best Tools for Every Job!

The **ACTION Utilities** Toolchest includes:

ACTION Files - Automatic file access and organization

ACTION GoMac - The Macintosh Task Bar™ and Start Menu

ACTION WYSIWYG - Multi-column view of actual typefaces and font families right in your application

ACTION Menus - Customize and create new menus organized any way you want!

Incredible savings in one powerful bundle. Guaranteed to make you more productive or your money back!



Phone: 800-344-9160 or 612-317-0344
 Fax: 612-317-0345
 email: sales@poweronsoftware.com
<http://www.poweronsoftware.com>

Choose 45 at www.macworld.com/getinfo

Now it's easier to scan than it was to shoot.

Easiest scanning ever
with Agfa ScanWise™
software

36 bit, 600 x 1200 dpi

PC or Mac® compatible

Starting at \$99*

USB, parallel port or SCSI

SnapScan™ scanners with 



www.agfahome.com

AGFA 

*AGFA MSRP 5/99. © 1999 Agfa Corporation. AGFA and the Agfa rhombus are registered trademarks of Agfa-Gevaert AG.

Choose 158 at www.macworld.com/getinfo

Remote-Control Software

TIMBUKTU AND HOUSECALL EASE TROUBLESHOOTING, COLLABORATION

THOSE OF US WHO NEED TO observe other users' actions, control their desktops, exchange files, and conduct voice or typed chats know that Netopia's Timbuktu Pro is a vital part of any network administrator's tool kit. Version 5.0 of this remote-control and remote-access software lets you connect more easily to users over the Internet or even by telephone, letting you help more users than ever before. If you simply want to offer remote help to

interface with too many palettes and buttons, and the fact that it won't run unless installed on the start-up disk.

HouseCall: Easy Help Tool

The new (despite the version number) HouseCall 5.0 lets you dial up or connect via the Internet to a Mac—but not a PC—so that you can control its desktop, observe the user's actions, exchange files, and have voice or typed conversations with that user. It's a perfect troubleshooting tool that can double as a collaboration tool. Just keep in mind that only HouseCall Doctor (the administrator component) can initiate file transfers; unlike Timbuktu Pro, HouseCall is not a two-way collaboration tool.

Both the Doctor and Patient components are extremely simple to install and use. Some of HouseCall's functions require a lot of bandwidth and are noticeably slow over a dial-up or Internet connection, but that's a limitation of those connections and not a flaw in HouseCall. Our only quibble is with the price of the Patient software (the Doctor software is free).

Macworld's Buying Advice

Timbuktu Pro is one of those programs that gets better with each update; version 5.0 is a worthwhile upgrade for most users and indispensable for those who aren't on a LAN. For anyone who regularly troubleshoots other people's Macs remotely, HouseCall 5.0 is a must.—GALEN GRUMAN



Knock Knock HouseCall 5.0 requires permission before letting the "doctor" observe, control, or work with files on the "patient" system.

friends and family who are having problems with their Macs, Netopia also offers a consumer-oriented version of Timbuktu, the elegant and useful HouseCall 5.0.

Timbuktu: More Connections

Timbuktu Pro 5.0 improves on its predecessors with three new features: an Internet Locator service, which helps you find Internet-based users by their e-mail addresses; an IP browser function, which looks for Timbuktu-equipped systems on the local TCP/IP subarea network; and the ability to use one line to both talk to the user and work on the remote system.

Although Netopia has dropped the conferencing feature—introduced in version 4.5—from Timbuktu Pro and made it a separate product (the \$30 Timbuktu Conference), owners of version 5.0 can download it free from the company's Web site. Timbuktu Conference is adequate, but it's not on par with Microsoft's free, Windows-only NetMeeting.

Timbuktu Pro 5.0's only other drawbacks are poor documentation, a scattered

HouseCall 5.0

RATING: **PROS:** Offers easy way to help users with their Macs remotely. **CONS:** A little pricey. **COMPANY:** Netopia (800/485-5741, www.netopia.com). **DIRECT PRICE:** Single-patient license, \$30.

Timbuktu Pro 5.0

RATING: **PROS:** Easier than with previous versions to connect to users over the Internet and via phone; strong collaboration and remote-management tools. **CONS:** Thin documentation; scattered interface. **COMPANY:** Netopia (800/485-5741, www.netopia.com). **LIST PRICE:** Single-user pack, \$100.

MACWEEK.COM

Expert Analysis
of the
Inside Story

Tom Clancy's **RAINBOW SIX**™

Play as if 6.0 billion lives depended on it.

The most revolutionary action/strategy game of its kind. Nothing else comes close to offering such an exciting combination of strategy, team-building, realistic three-dimensional graphics and true-to-life Special Forces action. The ultimate goal is to save yourself and the world from deadly terrorists. You must successfully complete 17 unique missions. If you die, the game isn't over, *THE WORLD IS*.



BUILD YOUR TEAM



PLAN THE ATTACK



EXECUTE THE MISSION



SAVE THE WORLD

INCLUDES
**MISSION PACK:
EAGLE WATCH**
THE OFFICIAL ADD-ON



COMING THIS FALL!

©1998 Red Storm Entertainment, Inc. All rights reserved. Red Storm Entertainment is a trademark of Jack Ryan Enterprises, Ltd. and Larry Bond. Rainbow Six is a trademark of Rubicon, Inc. Published and distributed by MacSoft, a GT Interactive Software Company. Other brand names are trademarks or registered trademarks. Photo ©Steven Galloway, Heckler & Koch.

MacSoft®

A GT Interactive Software Company
www.wizardworks.com/macsoft/

Macworld

BEST of SHOW
1999 NEW YORK EXPO

**CONGRATULATIONS TO
THE WINNERS OF THE
BEST of SHOW
July '99, NY Expo!**

**iBook/AirPort
Apple Computer**
www.apple.com

**Studio Artist
Synthetik Software**
www.synthetik.com

**EPicture
Beatware**
www.beatware.com

**SkyLine Wireless Network
Card
Farallon Communications**
www.farallon.com

**Rio PMP 500
RioPort**
www.rioport.com

**SoundJam MP
Casady & Greene**
www.casadyg.com

**LiveStage 2.0
Totally Hip Software**
www.totallyhip.com

**MS Outlook Express 5.0
Microsoft**
www.microsoft.com

**Mach Carrier Upgrade
XLR8**
www.xlr8.com

**Madden 2000 Football
Aspyr Media**
www.aspyr.com

**MultiPass C635
Canon**
www.usa.canon.com

Mathematica 4.0

THE LAST WORD IN NUMBERS

ANYONE WHO HAS USED MATHEMATICA 3.0 may find it hard to believe, but Wolfram Research actually found a few important improvements to make in version 4.0. With its beefed-up numeric operations and print and Web output, Mathematica 4.0 reaches far beyond its roots as a symbolic-computation program; it's now an all-purpose tool kit for any task relating to processing and communicating technical information.

Mathematica's number-crunching abilities—particularly with respect to large arrays of numbers—have improved

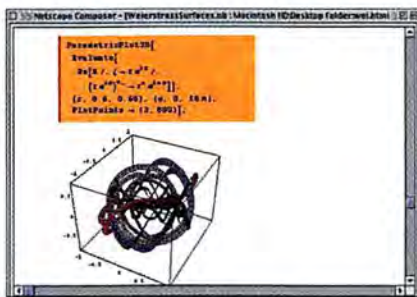

Everywhere at Once Mathematica 4.0 makes long-distance technical collaboration possible, by displaying notebooks as HTML files, with better-than-textbook appearance.

steadily over the years, but in version 4.0, they're downright revolutionized. A standard Power Mac G3 running the new version outperforms older SGI RISC workstations when processing huge data arrays and when running signal-processing applications. Specifically, the rewritten matrix operations store large and sparse arrays more efficiently, the code for the Fourier-transform routines has been optimized, and the program now reads HDF files at impressive speeds.

One reason this performance is crucial in science and engineering environments is that the previous leader in array processing, The MathWorks' MATLAB, is no longer being developed for the Mac. In tests using a ten-item matrix-math test suite, Mathematica 4.0 on a 266MHz Power Mac G3 beat MATLAB 5.2 on a 300MHz Pentium II system by an average factor of 4.3. And because Mathematica's automatic translators can convert MATLAB M-files to Mathematica notebooks, developers of custom matrix-processing

applications should be able to make the switch without too much inconvenience.

In the realm of advanced development aids, Wolfram has further refined Mathematica's rules for simplifying symbolic expressions and has added to the special-function list some math functions that previously defied useful computer definition. For science and math development, Mathematica no longer has any direct competitors on the Mac—or, for that matter, on PCs and Unix systems.

Appearance Is Everything

Mathematica 3.0 greatly simplified the task of producing journal-quality printed output, introducing features for using standard textbook-style notation rather than the computer-code output style used by most other math programs (including earlier versions of Mathematica). In version 4.0, the word-processing features are solid enough that you could easily make Mathematica your primary technical word processor. Not only are its editing features and style sheets more useful for technical work than those in Microsoft Word but printing as TeX and the newer LaTeX 2e files is also faultless.

Equally impressive is Mathematica 4.0's adaptation to the world beyond print. Notebooks saved as HTML generate files of HTML source code and folders of GIFs for artwork; notebooks can also contain hyperlinks to other notebooks or to URLs. The program displays any kind of math notation beautifully on the Web, and the new version can work with Web sound files as well as graphics.

Macworld's Buying Advice

Besides being faster and more compact than its predecessors, Mathematica 4.0 offers an amazing range of truly useful new features. And for students, the price is right: with an iMac and the \$79 Student Edition, you have the finest environment for technical computing and publication ever developed. It's simply the most impressive program I've seen in ten years of reviewing technical software.—CHARLES SEITER

RATING: **PROS:** Anticipates and solves a wealth of computing and publication problems; faster than version 3.0. **CONS:** None. **COMPANY:** Wolfram Research (800/965-3726, www.wolfram.com). **LIST PRICE:** \$1,495.

ONE GIANT LEAP FOR CANKIND

Painter 6 has landed!

- Next generation brush engine
- Astronomically improved user interface
- Warp speed performance
- Gravity defying text on a curve
- And a galaxy of new features

Want out-of-this-world results?
Reach for the can.

www.metacreations.com/blastoff
or call us today at 800-846-0111



MetaCreations
PAINTER 6
The Ultimate Painting Tool

Available at:

COMPUSA
THE COMPUTER SUPERSTORE

MAC WAREHOUSE

MICRO CENTER
THE SOFTWARE SUPERSTORE

©1999 MetaCreations Corporation. All rights reserved. MetaCreations Painter and the MetaCreations logo are trademarks of MetaCreations. All other trademarks are the property of their respective owners.

Choose 5 of www.macworld.com/getinfo

Image "MOON" Created In METACREATIONS PAINTER™ By RYAN WOOD © 1999

MetaCreations



InterView

INEXPENSIVE USB VIDEO CAPTURE

NOW SHOWING IN THE bargain basement: XLR8's InterView, the least-expensive video-capture device we've ever tested. Retailing for just \$99, the InterView comprises USB video-capture hardware and the full version of Strata's VideoShop video-editing program. It's an amazing value, although we encountered glitches when trying to capture video with programs other than VideoShop.

Compared with Avid Technology's \$299 Avid Cinema for Macintosh with USB (see *Reviews*, August 1999), the InterView hardware is far smaller, resembling a black butane lighter with three cables attached to it. One of the cables connects to the Mac's USB port, and the other two connect to S-Video and composite-video sources. Like Avid Cinema, the InterView captures video only, relying on the Mac's built-in audio circuitry to capture sound.

The InterView is a bit more finicky than Avid Cinema where system software is concerned, requiring Mac OS 8.6. Like Avid Cinema, the InterView requires Apple's latest USB firmware and includes the necessary installers for updating older iMacs.

For capturing and editing video, the InterView includes Strata's \$495 VideoShop 4.5. (You also get a scaled-down version of AirWorks' TuneBuilder, which builds custom-length music soundtracks in a variety of styles.) There's only one catch: rather than getting printed manuals for Video-



SUZANNE ROADY

Shop, you instead have to click your way through Adobe Acrobat files to learn the program. But still—such a deal.

Using VideoShop's Capture window, we were able to grab crisp video at a window size of 320 by 240 pixels and a frame rate of 30 fps. (Avid Cinema captures at the identical frame size and rate.) You can also grab 640-by-480-pixel still images. VideoShop is far more powerful than Avid Cinema's software, packing more effects and

editing features, but it's also a lot harder to learn and use. And unlike Avid Cinema, VideoShop can't export in RealVideo G2 format, so moviemakers wanting to publish in this popular Web video format will need additional software.

The InterView captured smoothly with VideoShop, but we encountered crashes and visual glitches when using other QuickTime capture tools, such as Web-cam software. XLR8 acknowledges incompatibilities with some QuickTime-based software and says the InterView 1.1 driver, due out by the time you read this, will fix the problem.

Macworld's Buying Advice If you're just getting started with digital video and you'd prefer some hand-holding, Avid Cinema may be a better USB capture system. But if you're on a tight budget and you're willing to read on-screen manuals instead of printed ones, InterView deserves a look. There's no cheaper way to get video into a USB-equipped Mac.—JIM HEID

RATING: ★★★ **PROS:** Inexpensive; powerful software. **CONS:** No printed manual for VideoShop; can't export in RealSystem G2 format; incompatible with some QuickTime software. **COMPANY:** XLR8 (888/957-8867, www.xlr8.com). **LIST PRICE:** \$99.

Now your Mac can do Windows EVEN BETTER!

New! 3.0



Faster

- PC disk performance
- Network access speeds

Easier

- Setup Assistant
- Configuration Manager

More Convenient

- Extensive USB device support
- Share a single Internet connection
- Sound Blaster® 16 sound support
- AppleScript support

Buy Virtual PC 2.0 now and get a free* upgrade offer valid on purchases starting 6/18/99

Connectix

www.connectix.com 1800 395 1804

* \$9.95 for shipping and handling

© Copyright Connectix Corporation. Connectix and Connectix Virtual PC are trademarks of Connectix Corporation. All other trademarks are property of their respective holders.

Choose 105 at www.macworld.com/getinfo

IT DOESN'T HAVE TO BE THIS WAY.

You've got Macs. You've got PCs.
You share a network. Now, your
printer's not fitting in.

GET POWERPRINT[®] FOR NETWORKS.

It lets both Macs and PCs print
to virtually any PC-printer across
an ethernet network. Whether
you're adding a Mac into an existing
network or a PC printer to a Mac
network, PowerPrint's unique
software and print server solution
allows you to use any printer,
anywhere.

PowerPrint for Networks.
Group therapy that works.

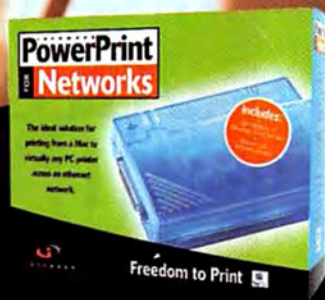

The Ideal Solution for
Mac to PC-Printing Across
an Ethernet Network.

Choose 32 at www.macworld.com/getinfo



INFOWAVE

To pick up PowerPrint, visit major retailers in the U.S. and Canada,
call 800.663.6112 or visit us online at www.infowave.com

SERIAL AND USB SINGLE-USE VERSIONS ALSO AVAILABLE.



C-2000 Zoom

TWO-MEGAPIXEL DIGITAL CAMERA

LAST YEAR, MEGAPIXEL DIGITAL cameras were the rage. Now it's time for two-megapixel cameras: models that produce images with 2 million pixels or more. The new Camedia C-2000 Zoom, the first two-megapixel camera from Olympus, is a point-and-shoot model that captures images at up to 1,600 by 1,200 pixels. It makes great images but falls a little short of its main competitor, the Nikon Coolpix 950 (♦♦♦♦½; "Digital Cameras Develop," September 1999).

Described by Olympus as a "filmless digital camera," the C-2000 Zoom looks and handles like a traditional film camera. It's small enough to fit in a shirt pocket, although it might make for an unsightly bulge under a suit jacket.

We looked at images captured under a variety of lighting conditions: daylight, on-board electronic flash, and tungsten lighting in a studio environment. With all three, images came out clear and sharp, with good color fidelity. However, the on-board flash tends to produce red-eye in shots of people unless you use the camera's red-eye-reduction feature.



ARNOLD TOBIAS

The camera's controls are all within the range of the right thumb and index finger, making them easy to reach. It provides a 3× optical zoom and lets you automatically or manually select an ISO rating of 100, 200, or 400. There's a manual viewfinder, which is nice, because the LCD is a true battery pig. (The optional NiMH batteries and recharger should be considered a must.) However, the center point of the viewfinder lens is 1.5 inches from the center point of the picture-taking lens, which can cause parallax problems when shooting subjects up close.

The camera saves images by using JPEG compression, but it also lets you save uncompressed TIFF images for maximum image quality. Like other Olympus cameras, the C-2000 Zoom uses 3.3v SmartMedia

cards for storage, supporting all capacities, up to the hard-to-find 32MB cards. The camera ships with an 8MB card, but you'll need higher capacity if you want to save files in the uncompressed TIFF format. Because the TIFF files approach 6MB apiece, you can get only one image on an 8MB card. The card holds about 7 images in the highest-quality JPEG mode and 15 images in the medium-quality mode.

Macworld's Buying Advice Overall, the Camedia C-2000 Zoom continues the Olympus tradition of good-quality digital cameras. Like many other digital cameras, it's a memory hog, and it lacks the single-lens-reflex capability of the Olympus D620L. But it captures great-looking images at high resolution and is reasonably priced. However, we still give the nod to Nikon's Coolpix 950, which offers a slightly wider color gamut and a viewfinder that's set closer to the picture-taking lens, reducing parallax problems.—RICK OLDANO

RATING: ♦♦♦♦ **PROS:** Good-looking images; high resolution. **CONS:** Viewfinder prone to parallax problems; flash tends to produce red-eye. **COMPANY:** Olympus America (516/844-5000, www.olympus.com). **COMPANY'S ESTIMATED PRICE:** \$999.

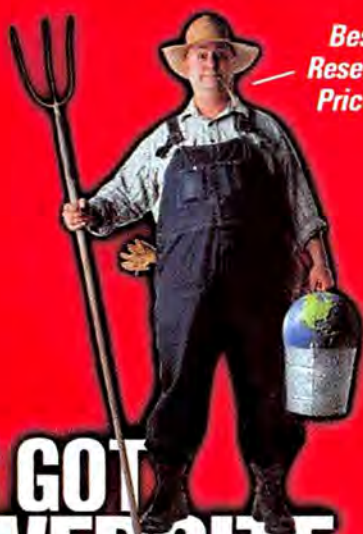

Best Reseller Prices.

HE'S GOT
A WEBSITE.
DO YOU?

E-Commerce Enabled

Resellers, We Refer Design Work

30 Day Money Back Guarantee

The Best Support and Pricing in the Industry.

Yeeehaaaaw! It's what you'll say when you sign up with or switch to Interland® web hosting. Prices from as little as \$19.95 a month. Dual DS-3 connections for extra speed. A whopping eighty megabytes of disc space. Guaranteed 99.9% uptime. 24x7 toll-free support for the wee hours. And pricing with absolutely no hidden charges. You'll be happy, we guarantee it!

Check out our website and discover why more and more people worldwide are trusting their websites to Interland. Whether you're a computer veteran or just getting started, you'll receive the best service, support and technology the industry has to offer. At a price that's right for you. Not to mention a great reseller program. Give us a call today, and let Interland bring you the world.

Pricing From \$19.95 per Month

Call Today 1-800-599-0547
(404) 586-9999

@ Speed. Reliability. Support.
interland®
Web Hosting
www.interland.net



Just mail or fax this completed coupon for your FREE 68-page Guide to Power Protection. Better yet, order it today at the APC Web site!

KEY CODE

<http://promo.apcc.com> m977z

(888) 289-APCC x8731 • FAX: (401) 788-2797

APC[®]
Legendary Reliability™

FREE 68-page Guide to Power Protection

- YES!** I want to know how to choose the right UPS for my system. Please send me my FREE 68-page Guide to Power Protection.
- NO,** I'm not interested at this time but please add me to your mailing list.

KEY CODE
m977z



Name: _____

Title: _____ Company: _____

Address: _____

City/Town: _____ State: _____

Zip: _____ Country: _____

Phone: _____

Brand of UPS used? _____

Brand of PC used? _____

Brand of Servers used? _____



**NO POSTAGE
NECESSARY
IF MAILED
IN THE
UNITED STATES**

BUSINESS REPLY MAIL

FIRST-CLASS MAIL PERMIT NO. 36 WEST KINGSTON, RI

POSTAGE WILL BE PAID BY ADDRESSEE

APC

KEY CODE: m977z

Department: **C**

132 FAIRGROUNDS ROAD

PO BOX 278

WEST KINGSTON RI 02892-9920



How to Contact APC

Call: (888) 289-APCC, *use the extension on the reverse side*

Fax: (401) 788-2797

Visit: <http://promo.apcc.com>,
use the key code on the reverse side

APC
Legendary Reliability™

What does a digital photographer do in the middle of a lightning storm?

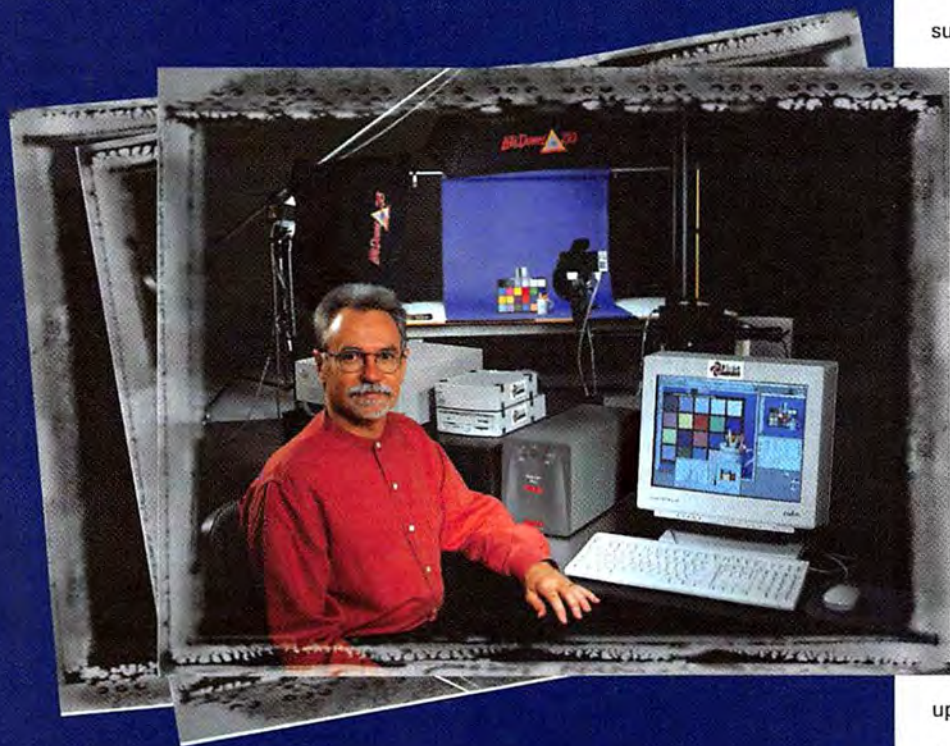

With APC battery backup power, he gets the picture. All the time.

Solutions starting at \$99.

You can find APC power protection products at:

PC Connection
800-986-2320

COMPUSA

MicroWarehouse
1-800-345-2045

CDW
Computing Solutions
Built for Business

Black Box Corporation
The World's Leader in Technology
1-800-541-4348



APC Back-UPS Pro®

Real Life
Dear APC: Bartlett Digital photography studio bills by the hour, which means we cannot tolerate avoidable downtime. The surge suppression and battery power of an APC UPS lets us finish the job, as scheduled, even with a temporary power outage.

- Tom Bartlett, central Florida

Fact
According to research by IBM, a typical computer is subject to more than 120 power problems a month. Surge protectors prevent only a fraction of the power problems that cause keyboard lock-ups, system crashes, corrupted data, and worst of all, motherboard burnout. An APC uninterruptible power supply (UPS) with surge suppression and battery back-

up protects your software, hardware, and most importantly, your work. APC Back-UPS Pro® provides clean, reliable power that lets you function at peak performance, giving you time to shut down during a power outage. Getting the picture? Visit the listed retailers to add APC's Legendary Reliability to your system.

**FREE 68-page Guide
to Power Protection.**

Learn how to choose the right power protection for your system.



Order now Key Code m977z
<http://promo.apcc.com>

888-289-APCC x8731 • Fax: 401-788-2797

APC
Legendary Reliability™

RichLink Author 2.1

FLAWED HYPERTEXT AUTHORIZING SYSTEM

AS POWERFUL AS HTML IS FOR creating annotated documents, it's easy to get lost jumping back and forth between links and the main text. With RichLink Author 2.1, you can create alphanumeric, image, sound, and QuickTime-movie annotations that appear on top of the main document when the user clicks on a link. (RichLink also supports conventional URLs that branch to separate documents.) You can view RichLink documents in any Web browser by installing a plug-in; best of all, both the plug-in and the authoring program are downloadable at no cost from Sentius's Web site. Sound too good to be true? It is—for now.

RichLink documents begin as raw text, which you can type directly into the application or import from a word-processing program. (RichLink crashed whenever we tried to import a Microsoft Word document, however; Sentius is working on a fix.) To create an annotation, you simply select the words you want to link to and either enter the annotation text or select an image, sound, or movie file.

In addition to defining annotations

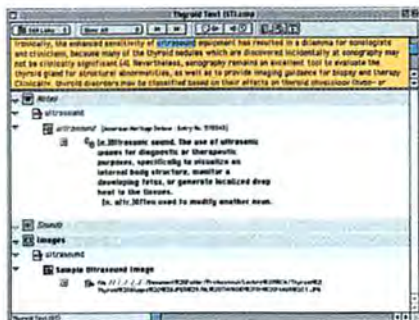

Pop-up Links The American Heritage Deluxe database lets you link definitions to words in your RichLink Author documents.

manually, you can link words in your RichLink document to databases you license from Sentius. This powerful function lets you provide word definitions and translations without entering them by hand. Sentius currently offers seven English and foreign-language databases, with legal and medical dictionaries on the way. Licensing fees vary, depending on how you plan to use and distribute your documents—for example, an educational license costs \$249, with a \$99 annual fee after the first year.

Alas, RichLink's problems range from cosmetic to serious. For example, text annotations were sometimes cut off at the edge of my monitor and the plug-in refused to dis-

play linked items in color. And, cheap RAM notwithstanding, RichLink is a memory hog—for those who are working with documents that exceed eight pages and use two or more databases, Sentius suggests 56MB for the authoring application alone. (Even with a memory allocation of 65MB, RichLink sometimes felt sluggish on a Power Mac G3/400.) The database files are also hefty, with the American Heritage Dictionary gobbling up more than 183MB of disk space.

Macworld's Buying Advice It's a shame to find fault with a hypertext authoring program that costs no more than the price of a download. But serious problems with RichLink's import and display functions make the program almost unusable in its current form. With a few vital tweaks, however, RichLink could become a compelling tool for electronic publishers on or off the Web.—FRANKLIN TESSLER

RATING: ★★½ **PROS:** Free authoring program and viewer; automatic word definitions and other annotations. **CONS:** Crashes when importing Word documents; links don't display correctly; steep memory requirements. **COMPANY:** Sentius (800/434-0474, www.sentius.com). **LIST PRICE:** Authoring program and viewer are free; database licensing fees vary.

FireWire® Solutions! HotLink™ FireWire Series

HotLink FireWire/PCI Card \$169

Ideal FireWire interface for PCI slots of your Beige G3 & Power Mac. Compatible with Adobe® Premiere®, Apple Final Cut Pro™ and new VST® hard drives.

HotLink FireWire PC Card \$179

Perfect add-on for your PowerBook PC Card slot. Compatible with Adobe® Premiere®, Apple Final Cut Pro™ and new VST® hard drives.

HotLink Hub \$99

6 port FireWire expansion hub; Includes cable and power supply. Enhances "Hotplug" by eliminating daisy-chain.

HotLink Repeater \$49

Allows additional 15 ft. extension for any FireWire peripheral. Up to 236 feet with multiple repeaters.

HotLink FireWire/SCSI Adapter \$99

External adapter allowing users to connect Fast SCSI devices through a FireWire port. Save a slot on your "Blue and White" G3. Includes cable.

FireWire 15 ft. Cables \$19



For Beige G3s and Power Macs with PCI slots



For PowerBooks with PCI slots.



FireWire Repeater

FireWire Hub

Orange Micro
inc.

"19 Years of Innovation and Excellence"

(714) 779-2772 • www.orangemicro.com

e-mail: sales@orangemicro.com

© 1999 Orange Micro, Inc. All rights reserved. Apple and FireWire are trademarks of Apple Computer, Inc., registered in the U.S. and other countries.

Introducing MacBuy.com. The first and only comprehensive buyer's guide from the editors of Macworld magazine. **MacBuy.com** gives you authoritative reviews of the most important Mac products available, and state-of-the-art testing from Macworld Lab. With MacBuy.com, you'll know...

...which products to buy.

And which to avoid.

Great deals on the Web.

And where to find them.

How much it costs.

And is it worth it.

From the publishers of
Macworld magazine

MacBuy.com

Review, Compare, Price and Buy.

Choose 60 at www.macworld.com/getinfo



Trouble mounting?

In a world where Windows and Macintosh incompatibility causes endless problems, DataViz offers a little help. MacOpener®. A convenient utility that surmounts all obstacles when your PC needs to read, write and format Macintosh disks.

With MacOpener installed on your PC, reading and writing files on a Mac-formatted disk, cartridge or CD is a breeze. MacOpener lets you open the disk on your PC just as if it were formatted for Windows. You can then view the contents and copy files to and from the disk from any Windows application. MacOpener automatically adds the right PC extension to Macintosh files, so you can launch a Windows application by simply clicking on the file. It even lets you format the Mac disk just as if it were a PC disk. How's that for trouble free performance?

At DataViz, solving PC to Mac compatibility problems is our business. As well as MacOpener, we offer Conversions Plus®, the premier file conversion program that translates hundreds of different file formats between PC applications or Macintosh and PC applications. Quickly and accurately. And offers over 1,000 file translation combinations, to solve almost any file conversion needs.

So discover for yourself that with DataViz, no file compatibility problems are insurmountable.

For answers to all your Mac to PC disk and file compatibility needs, call us at **1-800-270-0030 Ext 173** or visit our web site at **<http://www.dataviz.com/momacw>**



DATAVIZ®
Compatibility. Instantly.

Available at

COMPUSA
THE COMPUTER CONNECTION

MICRO CENTER
THE COMPUTER EXPERTS STORE

Fry's

Runs on Windows 3.1, Windows 95 & 98, Windows NT.

Choose 142 at www.macworld.com/getinfo

All product names are trademarks of their respective holders.

Stealth Serial Port

ADD A SERIAL PORT TO YOUR BLUE G3

APPLE'S LATEST POWER MAC G3 systems have plenty to offer, including USB and high-speed FireWire ports. But what do you do with your printers, modems, cameras, or other peripherals that require a serial connection? You could add a PCI card with a serial port, but that would consume one of only three PCI slots. A better answer is GeeThree.com's Stealth Serial Port, a \$50 device that plugs into the modem slot of blue Power Mac G3 models.

The Stealth Serial Port consists of a small interface board, along with a ribbon cable and serial-port connector. Because it takes up the modem slot, it precludes the use of an internal modem, but you can employ the Stealth to connect an external serial modem.

Installing the device is a breeze: you remove a metal plate from inside the computer, screw in the serial connector, attach a cable, and plug the interface card into the modem slot. Just add a system extension, and you're ready to go. Our only complaint is that the package didn't include the necessary software on a CD-ROM. Instead,

you have to download the extension from GeeThree.com's Web site. It's just a 40K download, but it's still an inconvenience. Fortunately, a CD containing the extension and additional software should be available by the time you read this.



SUZANNE ROADY

Once it's installed, the Stealth works just like the built-in serial connections in older Macs. For example, if you want to print, you select the printer in the Chooser and then select the port from the Connect To list. If you want to use LocalTalk, open the AppleTalk control panel and select Modem Port from the pop-up menu. To sync your G3 with a Palm device, open HotSynch Manager, click on the Serial Port Settings tab, and select Stealth Serial Port from a pair of pop-up menus.

We tested the port by performing several common tasks. We printed a ten-page document on an Epson Stylus Color 740; dialed into an Internet service provider, using an external U.S. Robotics modem; and transferred a 30MB application via a serial-to-serial connection. The port worked flawlessly in each case and was just as fast as a regular serial connection.

Macworld's Buying Advice The Stealth Serial Port is a simple, inexpensive hardware product that lets you use printers, modems, and other serial devices without consuming one of the blue G3's precious PCI slots. It precludes the use of an internal modem and currently requires that you download the software from the Web, but the latter is a minor inconvenience that should be fixed when the company begins shipping a CD with the product. If you're looking for a way to keep using those old serial devices, the Stealth Serial Port is the ticket.—STEPHEN BEALE

RATING: **PROS:** Easy to install; adds serial port without consuming PCI slot. **CONS:** Precludes use of internal modem; required software must be downloaded. **COMPANY:** GeeThree.com (info@geethree.com, www.geethree.com). **LIST PRICE:** \$50.

PowerBook® or Desktop VST has the portable solutions you are looking for.

The full VST product line for the New 1999 Version Macintosh® PowerBook G3 Series



Zip®100 Drive



SuperDisk™ Drive



6, 8 & 10GB Hard Drive

Battery Charger



Also available: Auto Adapters, AC Adapters and Li-Ion Batteries.

VST Products are available at www.vsttech.com

Apple, Macintosh, iMac, and PowerBook are registered trademarks of Apple Computer, Inc. Zip is a registered trademark of Iomega Corp. SuperDisk is a trademark of Imation, Corp.



Choose 73 at www.macworld.com/getinfo

Macworld.com is Growing!

MACCENTRAL

www.maccentral.com

Macworld
online

MacBuy.com

MacWEEK.com

iMacworld

job opportunities

800-937-3622

senior copywriter

Boston: A bachelor's degree in a creative field and advanced degree or equivalent in writing or other communications discipline is required for this senior-level position. Successful candidates will have 8+ years of experience as copywriters for major clients/projects and expertise at managing both the client and creative team. Responsibilities include ensuring overall client satisfaction, new business presentations, and developing existing clients.

help desk administrator

Dallas: The Help Desk Administrator supports a nationwide community via telephone, email, or in person as necessary. He/she provides first line support for Help Desk Technicians, with the responsibility to ensure all requests are being attended to, and tracks usage/response. Three to four years of help desk experience, a high level of organization, and excellent communication skills are required.

product manager

San Francisco: Reporting directly to the V.P. of Marketing, the Product Manager oversees positioning, release content and schedule, pricing, and sales training. Four to six years of experience with global high-technology companies required, preferably in the data communications, internet, and systems management industries. Excellent verbal and written communication skills and a technical background are essential.

human resources manager

Chicago: Must have proven ability to locate, screen, and interview top-quality candidates and extensive background managing administrative tasks such as benefit administration, payroll, evaluations, and data tracking. Excellent communication skills, knowledge of state and federal employment laws, and computer skills including word processing, spreadsheets, and presentation packages are also required.

putting intelligence to work

HireKnowledge®
Specialized Staffing Solutions

art director

St. Louis: Broadband interactive company seeks capable designer with broadcast/animation background. Candidates must have experience managing multiple simultaneous projects in various mediums including print, web, and video. The ability to implement a singular visual style across an online network as well as competence with administrative tasks like workflow and approval procedures are also required.

senior LAN administrator

Washington, DC: Qualified candidates will have 3+ years of experience in LAN administration or operations. Ideal candidate will have 2+ additional years of experience troubleshooting in a Windows NT/95 TCP/IP LAN WAN environment. A bachelor's degree in Computer Science or equivalent is required, along with Microsoft professional certification and a thorough understanding of basic TCP/IP networking.

graphic/web designer

New York: A company specializing in creating innovative websites for savvy small business owners is looking for top-level graphic/web designers with solid HTML skills and superior portfolio samples. Five years of experience in Photoshop, Dreamweaver, Fireworks, Flash, and Illustrator/CorelDRAW preferred. Applicants must provide at least 5 current URLs and detailed descriptions of their contributions.

Locations

- Baltimore
- Boston
- Chicago
- Dallas
- New York
- Philadelphia
- Providence
- San Francisco
- St. Louis
- Washington DC

<http://www.hireknowledge.com>

Choose 207 at www.macworld.com/getinfo

RealBasic 2.0

OBJECT-ORIENTED BASIC FOR THE MAC

PROGRAMMING IS NEVER GOING to be easy, since it forces otherwise sane people to think like computers. Folks with the imagination to do just that will appreciate Real Software's RealBasic 2.0.2, a development environment for experienced programmers and novices alike. In spite of its tendency to create large applications, it makes creating user interfaces—a heretofore odious task—commonly easy.

The BASIC language has evolved greatly since its invention, in the 1960s. Like other modern dialects, RealBasic is object-oriented. This approach lends itself particularly well to building user interfaces (UIs), whose windows and menus are typically labor-intensive to code with a traditional language such as C. Combining the organizational approach of object-oriented programming with built-in support for the Mac's standard UI elements, RealBasic makes creating an interface as simple as dragging and dropping elements from a tool bar into a window.

Once you've built your application's UI, you attach the BASIC code to each element within a Mac-like editing environment.

Programmers who are used to keeping source code in lengthy text files may find this process disconcerting at first, but RealBasic's approach makes sense for non-professional programmers and takes only a little getting used to for pros. RealBasic also offers a wealth of Mac-specific features, including support for accessing serial ports or sending and receiving data via TCP/IP.



Drag-and-Drop Development Creating this UI in RealBasic 2.0.2 was a simple matter of dragging the prefab elements from the tool bar into the window.

If you need database access or want to create software that runs under Windows, another \$200 gets you the professional version of RealBasic. RealBasic Professional's database-connectivity tools let you develop front ends to large databases and also lets you create a Windows version of your application with almost no additional effort.

But despite the program's ease of use,

neither version of RealBasic is perfect. For example, there's no interactive way to examine the methods associated with classes, including built-in ones, unless they're described in the admittedly abundant online documentation. A bigger problem is the size of the final applications RealBasic creates: a simple application for 680X0 machines is around 250K, and the PowerPC-native version of the same application weighs in at a hefty 800K uncompressed.

Macworld's Buying Advice Experienced programmers who would rather spend their time working on under-the-hood functionality than the UI or database-access glue will find RealBasic 2.0.2 well worth its price. Beginners and occasional programmers will find RealBasic accessible and useful for nearly the same reasons as the pros—the program takes on the error-prone task of getting the UI coding just right, leaving them to concentrate on their software's important internals.—STEPHAN SOMOGYI

RATING: **PROS:** Useful for pros and novices alike; simplifies UI creation; Pro version creates Windows applications. **CONS:** Creates large files. **COMPANY:** Real Software (512/263-1233, www.realsoftware.com). **LIST PRICE:** Standard Edition, \$100; Professional Edition, \$300.

TRAVEL TO DESTINATIONS OUT OF THIS WORLD.

Take a guided tour of the heavens at the push of a button with the Meade® ETX-90EC™ Astro Telescope.

Meade
ETX-90EC
Telescope.
Shown with
Autostar
Computer
Controller.



natural
wonders®
1-800-2-WONDER



1-800-52-FOCUS

See more in 20 minutes than Galileo saw in a lifetime. Galaxies, nebulae, star clusters, the planets, and more. New Meade digital technology makes finding any object in the sky as easy as pushing a button!

Choose from over 14,000 celestial objects stored in the Autostar™ hand controller's database, press GO TO, and the telescope moves to the object, places it in the field of view, and follows it across the sky — automatically, first time, every time. This is one telescope you have to see — and use — to believe.

Use the telescope's automatic guided tour feature to explore the rings of Saturn, mountain ranges on the Moon, or dust lanes in the Andromeda Galaxy. The Meade ETX-90EC Astro Telescope with Autostar Computer Controller — easy to use by anyone, anywhere, anytime.

Call 1-800-62-MEADE for a free copy of Meade Telescope Catalog #180 or for a dealer location near you. ETX-90EC: \$595, complete with 4-speed electronic hand controller (not shown). #497 Autostar Computer Controller: \$149. Meade telescopes and accessories are available at over 2000 dealer locations in the U.S.A. and Canada. Meade Instruments Corp., 6001 Oak Canyon, Irvine, CA 92618. FAX: (949) 451-1460. www.meade.com ©1999

Choose 79 at www.macworld.com/getinfo

PerfectFlat™ technology looks better with... Apple® Power and ViewSonic® on top!



Selecting your Mac® is only half the battle. Today, how you top it off is just as important. Innovations like multimedia monitors, flat panel displays and large screen CRTs are changing the old phrase "Monitor Sold Separately" to "Mac Sold Separately".

Take the new ViewSonic GF775 17" (16.0" viewable) monitor for example. This is the first 17" (various viewable) flat-screen CRT utilizing **PerfectFlat** technology to provide your Visual Computing Experience™ with precise, clear images. The GF775 provides an ultra-fine .24mm stripe pitch and 1600 x 1200 maximum resolution.

At ViewSonic, we offer the #1 best selling monitors and flat panel displays in the USA.* Buy with confidence from the company that's won over 550 industry awards. The GF775's warranty covers 3 years parts and labor. Plus 24 hour customer service, 7 days a week.

For more information on the company that's won over 550 industry awards, visit our website at: www.ViewSonic.com/mac



(Mac® Sold Separately)

(800) 888-8583 *Stanford Resources, Inc. Quarterly Monitrak Report Q1 '99 and Display Search Quarterly Supply vs. Demand Study CRT's Q1 '99. LCD Monitors, Q1 '99. Specifications subject to change without notice. Copyright © 1999, ViewSonic Corporation. All rights reserved. Corporate names and trademarks stated herein are the property of their respective companies. Apple and Mac are the registered trademarks of Apple.



ViewSonic
on top™
www.ViewSonic.com

Falcon 4.0

ADVANCED F-16 FLIGHT SIMULATOR

MACSOFT, PUBLISHER OF SUCH Mac gaming staples as Quake and Civilization II, has a knack for unleashing products that tax Macs to their very limits. Last year's Unreal, for example, was happiest with 80MB of real RAM and a G3 processor. This year, MacSoft has upped the ante with Falcon 4.0, a modern F-16 flight simulator that—to look and play its very best—requests a fast G3 processor, 3-D-acceleration hardware, and several hundred megabytes of hard-disk space. Woe is you if you attempt these dangerous skies with significantly less-powerful hardware.

The word *beffy* applies not only to Falcon 4.0's system requirements but to its manual as well. The tome's 600-plus pages hint that this flight sim is not to be taken lightly. Falcon is currently the closest thing Mac gamers have to piloting a real fighter jet and, as such, is as choked with electronic readouts and advanced weapons systems as the manual is with arcane acronyms. Users should therefore plan on spending days poring over the manual and running through the 31 training missions.



Wild New Yonder You too can rule Korea's airspace with MacSoft's Falcon 4.0.

Complex though Falcon 4.0 may be, that complexity comes with rewards. To begin with, under hardware acceleration, the game is gorgeous. The morning and twilight skies are properly hazy; missiles leave realistic contrails; and until you drop your fighter close to the deck, the rolling landscape looks like the real thing. Regrettably, *without* hardware acceleration, the game's graphics are chunky, and unless you have a very fast Mac and lots of RAM (meaning a 300MHz or faster G3 and 128MB of RAM), performance suffers with all the graphic goodies switched on.

According to fighter pilots who frequent newsgroups, Falcon 4.0's flight modeling is realistic. For us ground dwellers, this means

that although the plane flies smoothly, landing can be tricky—novice pilots should expect to damage a lot of landing gear and lose several planes along the way.

Falcon 4.0 comes with just about everything one should expect from a modern flight sim—a large theater of operation (the Korean peninsula), three campaigns choked with dozens of missions, network and Internet play that supports *mano a mano* dog-fights as well as up to four 4-player teams, and a mission builder that allows you to create your own missions. What it doesn't come with is a three-ring binder for the documentation, a handy feature in the PC version of the game.

Macworld's Buying Advice Falcon 4.0 will push the limits of both your Macintosh and your piloting skills. Casual flight enthusiasts will likely find the game too demanding, but those with the desire, patience, and hardware to fly the Mac's most realistic combat flight sim should strap into Falcon 4.0.—CHRISTOPHER BREEN

RATING: **PROS:** Breathtaking graphics; remarkably detailed flight sim. **CONS:** Stiff hardware requirements; steep learning curve. **COMPANY:** MacSoft (800/229-2714, www.wizardworks.com/macsoft/). **LIST PRICE:** \$50.

MacBuy.com
The Macworld Buyer's Guide

iMacworld
Your iMac Info Center

Macworld.com
The Macintosh Authority

MacWEEK.com
Expert Analysis of the Inside Story

MacCentral.com
Mac News First

We've got answers for everyone.

www.macworld.com

www.macbuy.com www.imacworld.com www.macweek.com www.maccentral.com

\$ \$ \$

Buying online?

Will it work?

If you didn't know then, you will now. Introducing MacBuy.com. The first and only comprehensive buyer's guide from the editors of Macworld magazine; with MacBuy.com you'll know...

...which products to buy. **And which to avoid.**
The best deals on the Web. **And where to find them.**
How much it costs. **And how much it's worth.**

www.macbuy.com
The Macworld Buyer's Guide

As Easy as 1-2-3

Whether you're searching for a product review or finding the Pick Of The Day, it's easy with MacBuy.com's clean user interface and intuitive navigation.

Convenience and Value!

The latest and lowest prices from leading Mac resellers. Plus, convenient links to their sites so you can purchase the product you want instantly! MacBuy.com tells you how to shop smart.

Powerful and Easy...

to-use search engine. You can search by product or vendor name, or use the Power Search button to search by multiple criteria, such as rating and price.

Support from Apple

Literally. Built with Apple's WebObjects, MacBuy.com is solid as...well, a rock.

From the publishers of Macworld magazine

MacBuy.com

Get it right.

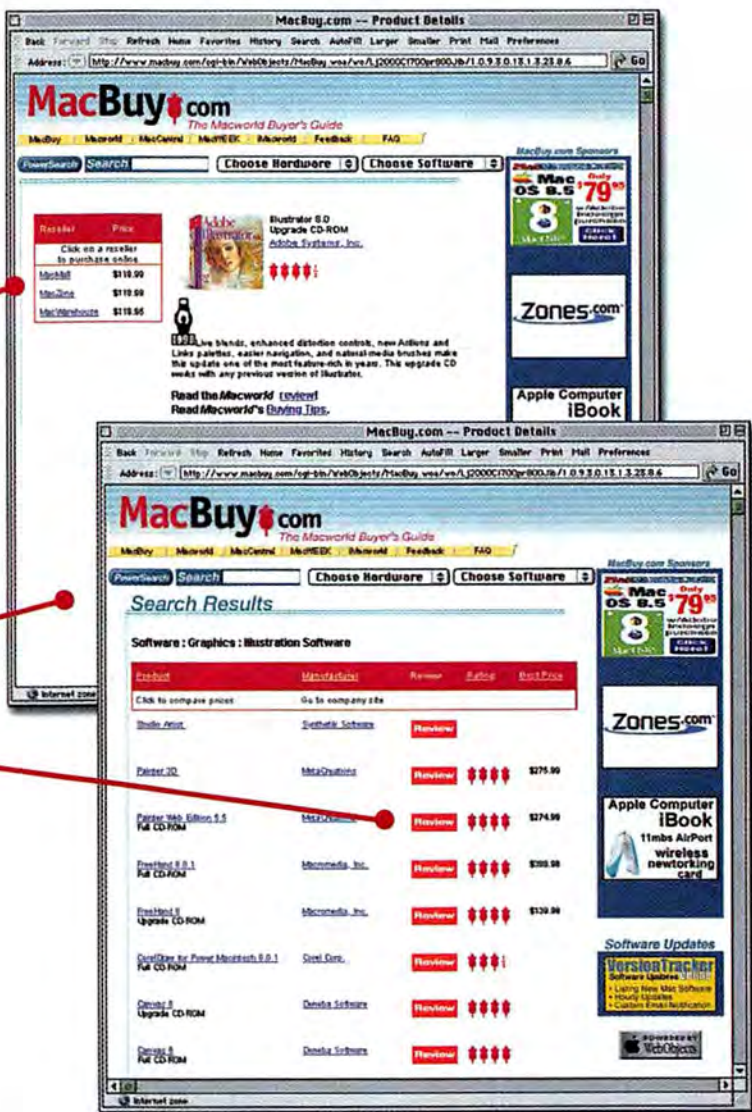

UNREAL™ TOURNAMENT

An all-new single- and multi-player tournament game.

[Does not require Unreal to play.]

Learn team-based gameplay with and against virtual 'bots' — completely customizable with superior A.I. Command your own 'bots' to defend, attack and cover you in team play.

Get online and frag on the server of your choice with a couple of clicks.

All-new and enhanced weaponry — the redeemer, the IMPACT hammer and more. Plus more than 30 unique environments.

COMING SOON!



Enter the Unreal World at
<http://unreal.gtgames.com>

MacSoft®

An affiliate of GT Interactive Software
www.wizardworks.com/macsoft/

Unreal Tournament ©1999 Epic Megagames, Inc. All Rights Reserved. Created by Epic Megagames, Inc. In collaboration with Digital Extremes. Published and distributed by MacSoft, an affiliate of GT Interactive Software Corp. Unreal and the Unreal logos are trademarks of Epic Megagames, Inc. All other trademarks are the property of their respective companies.

Choose 29 at www.macworld.com/getinfo

The Game Room

Here They Come!

GREAT NEW GAMES ARE ON THEIR WAY. HERE'S A SNEAK PEEK.

by Christopher Breen

As I sit in the cramped back bedroom I call my office, I think to myself, "Thank God summer is over." Yes, I slogged through the warm days and lengthy twilight evenings and prayed for the onset of blessed winter. While stubborn contrariness may explain this desire, I'm afraid the truth is even less attractive—it's addiction, pure and simple. As you might have guessed, I've got a bad jones for computer games and I need a fix of the good stuff every so often or I get a little twitchy.

The problem is that because winter embraces the Holiday Shopping Season, game publishers slate the release of their best and brightest products for December. Not that the summer is completely devoid of new games—I'll manage to get by with *Quake II*, *Age of Empires*, *Descent 3*, *Rainbow 6*, *SimCity 3000*, and *Fly* until winter arrives. But there's some tasty stuff yet to come. I've made my list, checked it twice, and here's what's on it.

Sure as Shootin'

Despite the best efforts of those who blame society's violence on video games rather than the NRA's political payola, first-person shooters are as popular as ever. Three outstanding representatives of the genre are slated to appear before the holidays: Sierra's (425/746-5771, www.sierra.com) *Half-Life*, Activision's (310/255-2050, www.activision.com) *Quake III: Arena*, and MacSoft's (800/229-2714, www.wizworks.com/macsoft/) *Unreal Tournament*.

It's no fluke that hundreds of thousands of copies of *Half-Life* made their way to PCs earlier this year. The game not only looks great under hardware acceleration, features more-realistic character move-

ment than shooters of the past, and lacks hard-and-fast boundaries between one game level and another, but *Half-Life* also offers characters who behave more like living beings than scripted robots. Better still, *Half-Life*—unlike most shooters—actually has a compelling story line: as Gordon Freeman, a 27-year-old scientist, you find yourself unintentionally involved in a secret war between the government and an icky alien race. Your job is to save humankind—and if that means leaving this world

these single-player levels are designed to mirror networked play.

Although multiplayer battle is the point of the two games, they approach it differently. *Quake III: Arena* focuses exclusively on DeathMatch play, whereas *Unreal Tournament* will offer both DeathMatch and team play. With hardware acceleration, both games will be visual delights. *Unreal Tournament* should be just as beautiful as its predecessor, *Unreal*, and *Quake III: Arena* will feature rounded surfaces and effects such as volumetric fog that shrouds opponents until they're close enough to carve with the chain saw.

Speaking in the Third Person

Forms of battle that take place above—rather than behind—the gun are also coming, in the form of Aspyr Media's (888/212-7797, www.aspyr.com) *Tomb Raider III*, Blizzard Entertainment's (800/953-7669, www.blizzard.com) *Diablo II*, and Bungie Software's (800/295-0060, www.bungie.com) *Oni*.

Surely you're familiar with the *Tomb Raider* series, so suffice it to say that Lara's back with

more of what Lara does best. In *Tomb Raider III*, Lara and her environment are more polygon-rich, she carries an enhanced weapons set, and you accompany her to such exotic locations as Antarctica and Area 51. Likewise, Mac gamers know the ins and outs of *Diablo*, the outstanding kill-the-dungeon-dwelling-baddies adventure. *Diablo II* will offer five new character classes, four towns, a host of new weapons and enemies, and hardware

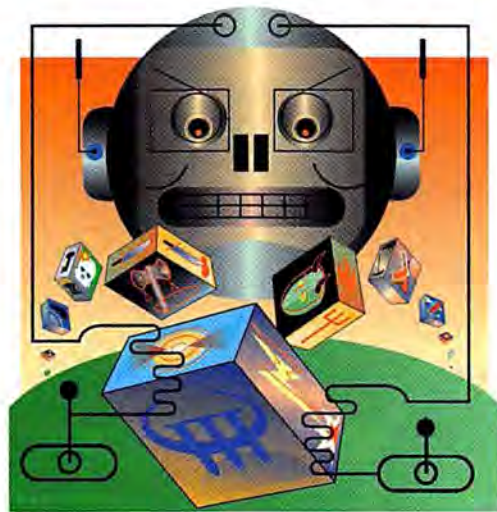

to kick alien patootie, then so be it.

Quake III: Arena and *Unreal Tournament* take a different tack by dispensing with the plot entirely. Undoubtedly you've read game reviews that state, "Great as the single-player game is, it can't hold a candle to networked DeathMatch play." The developers of *Quake III: Arena* and *Unreal Tournament* realize this and have focused these games on head-to-head combat. Although both games offer a single-player mode,

continues

acceleration for even richer and more-beautifully lit environments. Additionally, you'll be able to enlist other characters to accompany you on your quests.

Oni is the one wholly new third-person game coming to the Mac this year (or early next year). It's a hand-to-hand and gunplay 3-D action game done in a Japanese anime style. Featuring immense indoor and outdoor environments, dozens of opponents, a fair mix between fisticuffs (and footcuffs, elbowcuffs, and kneecuffs) and artillery, hardware acceleration (required), and more moves than United Van Lines, Oni should be a must-have for action gamers.

Bungie Software was kind enough to show me a very early version of a game that will blow network gamers away—Halo, a third-person-perspective war game pitting humans against aliens. The game will allow up to 32 players—16 players per team—to have at it across a network or Bungie's own Internet-based BungieNet.com. Halo is drop-dead gorgeous and encourages players to adopt different skills—for example, you can hone your skills as a driver or gun-

ner on a land-based vehicle. Regrettably, you won't see it until the middle of 2000.

Strategic Decisions

The High Holidays will also bring us two strategy games that are big, big, big in the PC world—Sid Meier's Alpha Centauri, published by Aspyr, and MacSoft's Civilization: Call to Power. Both are turn-based games, and each features civilizations that peer into the future. In addition to tarding up Civilization II's graphics and interface, Civilization: Call to Power encompasses more years than Civ II—it includes those years between 4000 B.C. and A.D. 3000. Alpha Centauri takes up where Civ II left off—the descendants of those aboard the spaceship you launched at the end of Civ II have been broken into seven factions with very different ideas about how a planet should be run. You must compete against the other six factions for control of the planet.

Patience Pays Off

Two of the most common complaints you hear among Mac gamers are (a) there

are *no* sports games for the Mac, and (b) why can't LucasArts commit to the Mac platform? Partial answers to both are coming later this year. Aspyr is bringing a *huge* mainstream football game to the Mac—Madden NFL 2000. And LucasArts (888/532-4263, www.lucasarts.com) has committed to putting Mac gamers behind the controls of their very own pod racer in Star Wars: Episode 1 Racer. Neither of these developments will drop basketball and baseball games or a Mac-compatible version of LucasArts' Grim Fandango in my lap by December, but they're both a *very* good start.

Shakin' All Over

These are just *some* of the highlights of the season. I haven't even touched on Baldur's Gate, Pro Pinball: Big Race USA, Aliens Versus Predator, and Interstate 76. With games of this caliber coming down the pike, it looks like winter's going to be a long, *long* time coming. **m**

Contributing Editor CHRISTOPHER BREEN
coauthored *My iMac* (IDG Books Worldwide, 1999).



Holiday Wish List From left to right, top row: Diablo, Halo, and Quake; middle: Oni (both oval screens); and bottom: Half-Life, Madden, and Unreal.

put our



to work for

you

#1.

Let the Macworld Lab help you make the right purchase decisions.

Whether you depend on the stamp of approval of an Editors' Choice award,

a five-mice rating, or the authoritative test

data presented in our benchmark charts —

you can put our lab to work for you.

Something obvious happens when a publication is backed by the most experienced, capable and thorough product testing in the Macintosh industry — more serious Mac buyers rely on it to make smart purchase decisions.



Macworld



It's colorful.

It's wireless.

It fits in your backpack.

Meet the iBook

by David Pogue

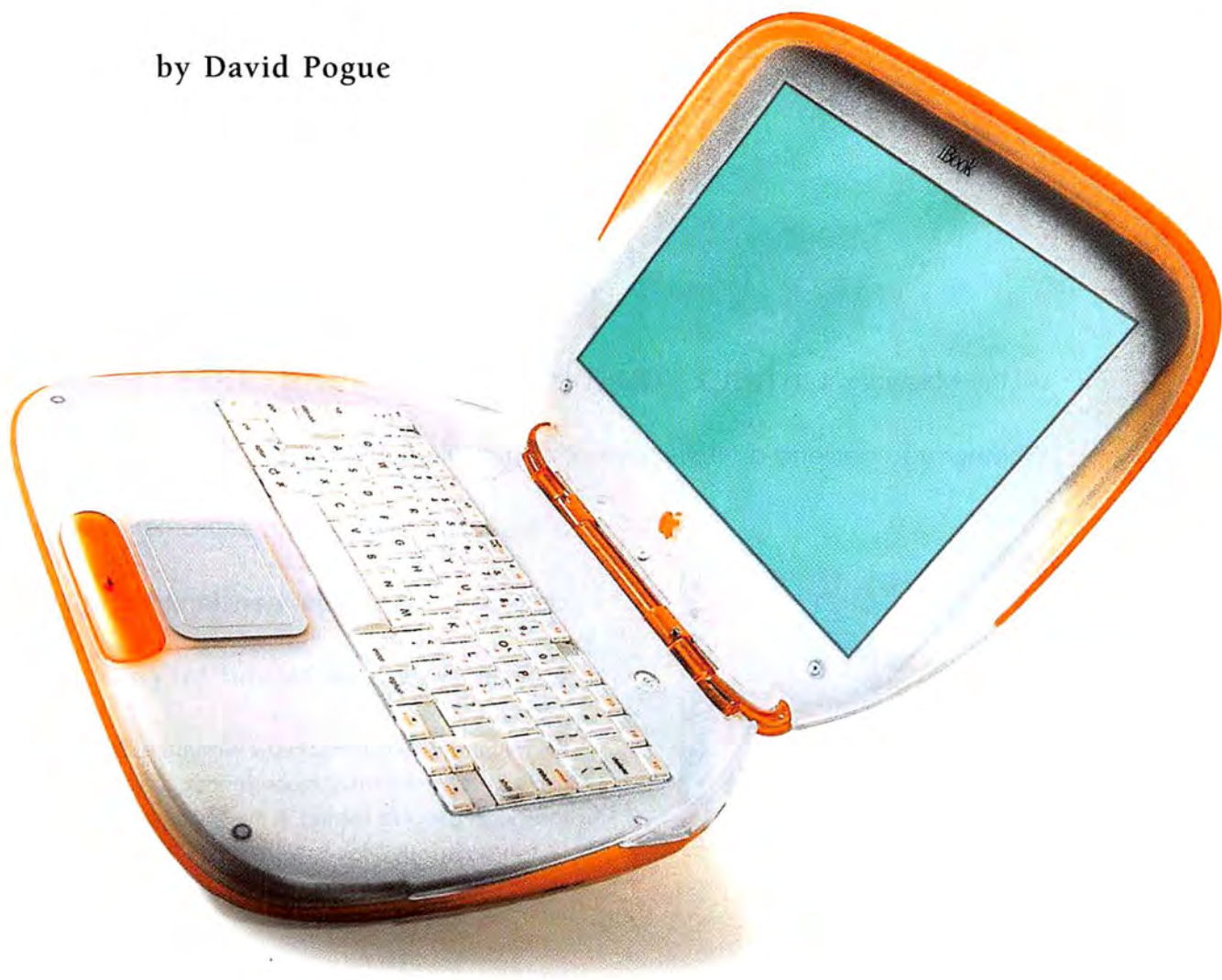

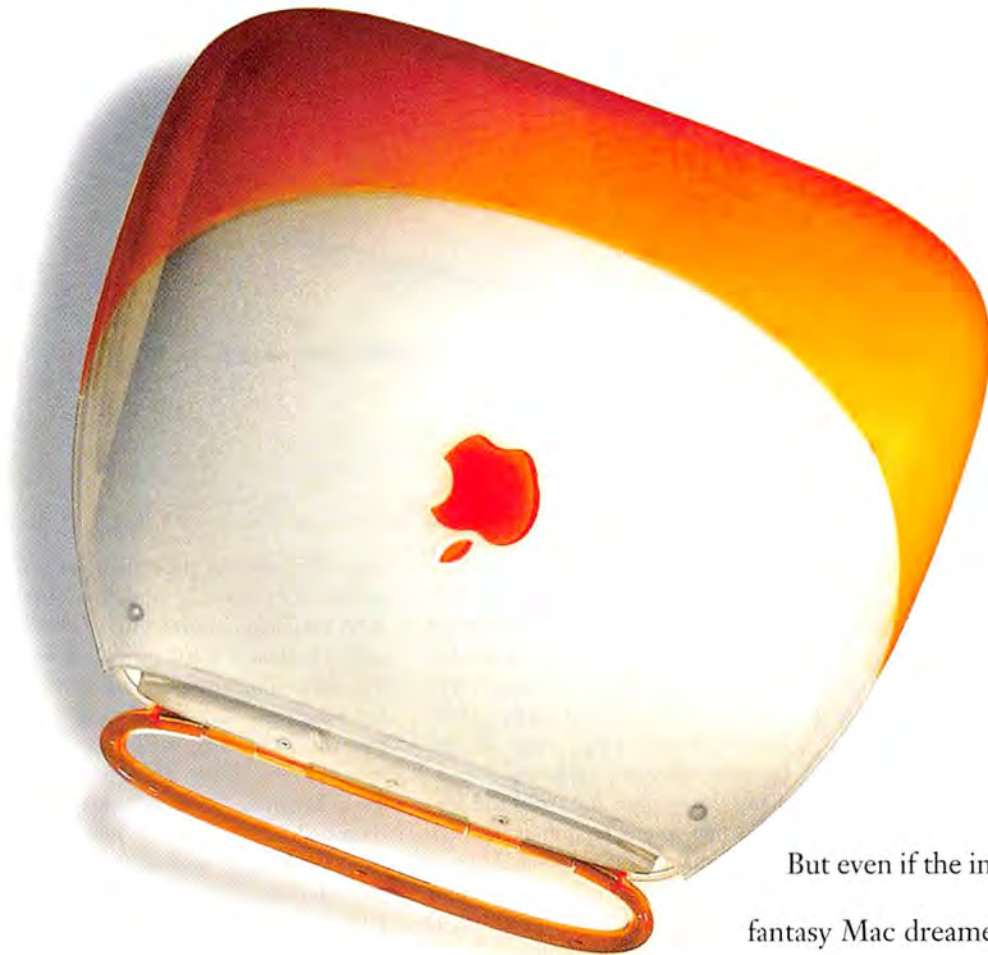

Take Me with You
The hinged handle of the iBook is ideal for users on the go.

If all the rumors and hysterical anticipation about the iBook had proved to be true, Apple's latest contraption would be a 2.2-pound, touch-screened, \$900 miracle Mac. Instead we've got the iBook, a candy-coated, flattened iMac whose rugged design and bright colors are sure to win the hearts of first-time laptop owners and Web-addicted couch potatoes everywhere.

But even if the inexpensive iBook isn't the fantasy Mac dreamed up by the imaginative rumor mill, it's no less amazing. The iBook's creative design, its wild blueberry and tangerine colors, its special features, and yes, even its \$1,599 price tag break the mold of portable computing and, as with the iMac that preceded it, are likely to send colorful shock waves throughout the computer industry.



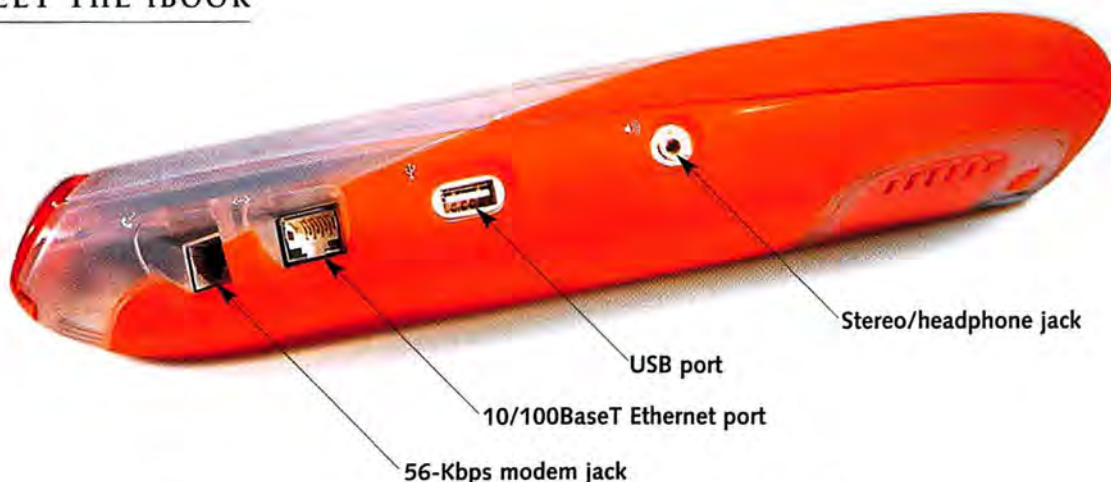

iMac to Go

It's no surprise that the iMac's little sibling has all the family traits of a fun, low-cost computer. The iBook's specifications closely match the iMac's (see the table, "All in the Family: iBook and iMac Compared"), and the two-tone, translucent Lexan case is just as bright as the iMac's. The screen is a 12.1-inch active-matrix-TFT, 800-by-600-pixel, millions-of-colors display that you can switch to 640-by-480 mode when you want to enlarge the picture. And like the iMac, the iBook comes with an assortment of preinstalled software: AppleWorks, games such as Pangea Software's Nanosaur and Bugdom, plus the usual Internet freebies (Microsoft Internet Explorer and Outlook Express, and America Online).

Space-Age Design But of all iMac features, the one that laptop fans covet the most is its astonishingly smooth, unusual design: It wakes up from sleep when you open the lid. The power cord wraps, yo-yo-like, around its own chrome disk, forever eliminating the two-minute untangling ordeal you normally face when unpacking a laptop. The power socket on the side of the

iBook glows orange when the battery's charging, green when it's full; either way, you'll never again rush off to a final exam with a drained battery, unaware that your adapter was plugged into a dead outlet. The handle, at the hinge edge of the portable, provides a safe and convenient way to grab and carry the laptop; when you let go, hidden springs snap the handle flush against the case.

Cosmetically, the iBook design owes a debt to, of all things, sci-fi space movies. The indicator light doesn't just blink to indicate when the Mac is asleep—it *pulsates* like a B-movie prop. But no computer component has ever looked quite so much like one of Fox Mulder's extraterrestrial visitors as the UFO-shaped AirPort Base Station. And instead of a cheap black plastic touchpad, the iBook's pointing surface is a sheet of hard, silver, mirrored Mylar.

Built to Last In addition to the sci-fi fun of the new iBook, a raft of more functional design implementations makes this portable rugged enough for the clumsiest of users. For starters, the colored exterior rubber coating is four times as thick as on pre-

vious PowerBooks, greatly diminishing the likelihood of scratches and nicks from being shoved into an overstuffed backpack. Every possible moving, breakable, and protruding part has been removed, both inside and out: there's no fan, no flimsy port cover, no PC Cards, no removable-media bay, not even a latch to keep the clamshell halves together. Instead, a two-stage hinge spring snaps and holds the laptop shut like the hinge of a wedding-ring box. And Apple is quick to point out, too, that the iBook's ultrarounded shape wasn't sculpted just to look cool; the rounded shape dissipates the force of sudden blows, much as does an eggshell, protecting the precious contents.

All the Right Keys

Gone are the struggles between big hands and little keys—the iBook keys are every millimeter as large as those of a standard desktop keyboard. And not only are the keys larger but the inverted-T arrow keys are also arranged in a separate cluster. And similar to the PowerBook G3's, many of the keys perform secondary functions, which are colorfully indicated on the key tops. You

All in the Family: iBook and iMac Compared

Product	Price	CPU	Memory	Hard Drive	Storage	Modem	Ethernet	Connections	Display Size
iBook	\$1,599	300MHz	32MB	3.2GB	24x CD-ROM; no floppy drive	56K built-in	10/100BaseT	USB; no SCSI, no FireWire	12.1 inches
iMac	\$1,199	333MHz	32MB	6GB	24x CD-ROM; no floppy drive	56K built-in	10/100BaseT	two USB ports; no SCSI, no FireWire	15 inches

can trigger these alternative functions—turning the right-hand half of the keyboard into a numeric keypad, for example—by pressing the Fn key in the lower-left corner.

Functionality Those little function keys that almost no one uses deserve special recognition. The first six, F1 through F6, control the screen brightness, speaker volume, num lock, and mute functions of the laptop—if you don't press the Fn key. Only when you do press the Fn key do these keys trigger their labeled F1-through-F6 functions, if any. Using the Keyboard control panel, you can reverse this convention, so that the brightness and speaker controls take effect only when you press the Fn key. The remaining F-keys, F7 through F12, do something smart when pressed for the first time: they summon a dialog box that can launch a favorite program, document, or networked disk on subsequent presses of that key. And if you prefer, you can select the icons of your favorite items from the Keyboard control panel instead: just drag any icon from the desktop into the corresponding F-key slot in the control panel's Function Keys dialog box. Finally, F-keys are about to become useful without making users install utilities, such as CE Software's QuickKeys.

Removable Keyboard The keyboard offers another friendly touch: In the gaps between the banks of function keys are small sliding latches you can retract with your fingernails. Without any tools, you can lift out the entire keyboard, revealing the uncluttered insides of the iBook.

Once the keyboard is removed, you can easily access the RAM-expansion slot, which can accommodate a single memory module with a



Tangerine Dream

The rugged design and lack of flimsy doors and port covers make the iBook a dream come true.

capacity of 32MB, 64MB, or 128MB. Take note—the iBook requires 1.25-inch, 3.3-volt, SODIMM SDRAM. Because this RAM type is not the same memory used in the PowerBook G3, owners of Apple's professional portables cannot swap RAM between a G3 and an iBook.

Not so long ago, Apple made it nearly impossible for users to pry open a PowerBook. To add memory or enhance the system, users *had* to have professionals make the adjustments—or risk voiding their warranty. But the iBook is a different story. Surprisingly enough, directly to the right of this RAM slot under the keyboard is a crystal-clear diagram that shows you how to install memory.

Lock Up the Keys Despite the convenience and simplicity of opening the iBook to add more RAM, teachers and parents need not cringe: Apple also included a special screw tucked between two function keys that, when turned, locks the keyboard shut—a handy feature for teachers

looking to deter young scientists who want to research what happens when Apple circuitry meets apple juice.

Keeps Going and Going

On the underside of the iBook, two thumbscrews secure a plastic panel covering the compartment for the long, thin chrome battery. Unlike with the G3's battery, you can't change the iBook's battery while the computer is asleep—you must shut down first. Apple claims that this rounded battery lasts six hours per charge; but as Macworld Lab battery tests on the bronze-keyboard PowerBook G3 demonstrated (see *Reviews*, September 1999), Apple's estimates, like those of other laptop makers, are not the real-world results most users will get, since the company's tests are performed with the brightness dimmed while the computer is running low-horsepower programs. For the final word on the iBook's battery life and performance, stay tuned for Macworld Lab benchmarks of the first ship-

Colors	Add-ons
blueberry, tangerine	Wireless Networking AirPort card, \$99; AirPort Base Station, \$299
blueberry, tangerine, strawberry, lime, grape	none



Open Sesame

Every iBook comes with a 24x CD-ROM drive similar to the one in its big sibling, the iMac.



Untangled

The yo-yo-like power cord eliminates the messy cables of portable computing.

ping iBook. One thing is for sure: the iBook charges its battery completely in two hours when asleep, four hours while in use—faster than most other portables.

Long-Lasting Although it may not actually get six hours of life per charge, the iBook's battery does run longer than that of any previous PowerBook. Apple achieved the extra battery life by rewriting its power-management software from scratch. Between key presses when you're typing, and even in the microseconds between the pixel-to-pixel movements of what appears to be a continuous mouse drag, the iBook processor takes extremely short catnaps. When you're typing, Web-browsing, or even crunching numbers, the portable's CPU winds up sleeping almost 95 percent of the time, thus preserving the battery's longevity.

Sleep Tight Along with the clever power-management software comes a new feature you can use when shutting the iBook down or putting it to sleep. Using options in the new Energy Saver control panel and Control Strip, you can ask the iBook to save the current contents of RAM into a single file on your hard disk. Doing so when putting the Mac to sleep offers only one arguable benefit: if you shelve the iBook for so many months that its battery goes dead in storage, your open programs and documents will still be there when the machine finally gets power again. But when you shut down with this save-RAM-contents option turned on, the advantage is immediately apparent: starting up the iBook again takes far less time than usual. You don't even see the usual parade of extensions, the "Welcome to Macintosh" logo, and so on—instead, you're taken directly back to whatever you were doing when you shut down, complete with open and even unsaved documents.

More to Come

Perhaps the most intriguing new power-management development of the iBook lies directly underneath it: two tiny metal contacts. These contacts are designed to accommodate mass iBook chargers, such as the one recently announced by VST Sys-

tems, that let teachers and employers snap multiple iBooks onto the pins of such a charger quickly and efficiently, without having to plug in and unplug power cords.

Welcome to the AirPort

By far the most revolutionary and exciting iBook feature, the one that redefines the word *portable*, is the AirPort card. This \$99 PC Card-type add-on fits into a special connector under the keyboard. Once the card is installed, your iBook can communicate with a modem, Ethernet network, cable modem, DSL hookup, or other iBooks wirelessly—from up to 150 feet away—via radio waves that zoom around corners, under furniture, and through concrete walls at 11 Mbps (10BaseT Ethernet speed, about 1 megabyte per second). This expensive technology, formally known as the IEEE 802.11 spec, has been available on cards developed by Lucent. Now, thanks to Apple, this kind of wireless networking is available for less money and complexity.

Get Unconnected For multiple iBooks in a classroom or in a workplace setting, Apple offers the \$299 AirPort Base Station. This four-inch flying saucer is fully equipped with a phone jack; an Ethernet port; three space-age indicator lights; and wireless receivers that communicate with the iBook antennas, which are built-in and faintly visible through the translucent plastic flanking the screen. With the Base Station, up to ten computers can surf the Web simultaneously, sharing the bandwidth of the Base Station's built-in 56-Kbps modem—or whatever faster Internet connection you've plugged into its Ethernet jack. Forty-bit encryption is built-in, and you're required to enter a password before connecting to the wireless network. You can even set up multiple Base Stations—special software lets you name each individually—and switch your iBook communications from one to another, using a special Control Strip tile. If you buy an Ethernet crossover cable, which costs about \$8, you can connect one traditional Macintosh to the wireless network

or simply use the wireless AirPort Ethernet jack to connect to an existing Ethernet network.

iBook to iBook

Only if you read the fine print of Apple's literature, however, does it become clear that you don't need a Base Station to enjoy an AirPort card. For example, using the included Control Strip module, you can direct your iBook to communicate with another iBook *directly*, through the air instead of via a base station. (Did you get that, multiplayer-game fans?) Moreover, you can use an iBook as a base station—that is, if you plug an iBook into a phone line or cable modem, up to ten other iBooks can share its modem (or other Internet connection) wirelessly. The mind reels: students can turn their assignments in to the teacher's iBook without plugging in any wires. Corporate documents can be distributed to all the attendees sitting around a boardroom table—or down the hall, or up a flight. Homebodies can sit in front of the TV downstairs, surfing the Web via the cable modem connected in the upstairs office.

More Wireless If you've just wired your house for Ethernet or bought a home-networking kit that connects your computers via the telephone wiring, you're probably smiting your forehead. If you're anyone else, however, you're probably wondering how your existing PowerBook or desktop Mac can get into the wireless action. Farallon's upcoming Skyline PC card (510/346-8000, www.farallon.com; approximately \$300) lets existing PowerBooks talk to AirPort networks, with a range of 300 feet. No company has yet announced a desktop product for this purpose, but surely it won't be long. Apple's attractive wireless-networking contraption may also crumble the remaining walls between Macs and PCs, since the 802.11 technology of the AirPort is cross-platform and wireless cards are already available for Windows PCs.

What's Missing

Even though the look-and-feel of the iBook is captivating, the iBook is not the answer for everyone and the



All the Right Keys

Apple's removable full-size keyboard is a sure fit for big hands.

bright Creamsicle colors may clash with the tastes of the corporate world and varsity linebackers. And professional users may miss the elements found on the Power Mac G3 laptops: PC Card slots; a microphone; an infrared jack; a monitor-out jack; and, of course, a floppy drive.

Add-on products fill some of these gaps. For example, Griffin Technology (615/255-0990, www.griffintech.com) has announced a \$25 USB microphone/line input called the iMic, and AVerMedia's (408/263-3828, www.aver.com) USBPresenter offers video-output capabilities via the iBook's USB port.

Some might argue that there's little need for a PC Card slot since the iBook comes with both a modem and an Ethernet connection—the most common uses for PC Cards. However, digital-video professionals may grouse about the lack of a FireWire connection, made worse by the lack of a PC Card slot that could have accommodated a FireWire PC Card, such as the FireWire To Go, from Newer Technology (316/943-0222, www.newer-tech.com).

The bottom line on the iBook's missing features: our only guess is that if Apple had endowed the iBook with every feature of its professional laptop line, nobody would pay \$1,000 more for a PowerBook, whose sales will be badly cannibalized by iBooks as it is.

The Last Word

Yes, it's possible to grumble about the iBook—barely. For example, the full-size keyboard and the rugged Lexan shell make this portable larger (13.5 by 11.6 by 1.8 inches) and slightly heavier (6.6 pounds) than a PowerBook G3. And as with other products in high demand, it's safe to predict iBook shortages and a few technical glitches in the first months of its release.

Grumbling about the price, however, is not permitted. Even if you ignore the iBook's creative design and snug fit and finish, the \$1,599 iBook is a bargain when compared with Windows laptops. The least-expensive Dell Inspiron, for example, is \$1,799, doesn't include Ethernet, and contains a ridiculously slow 366MHz Celeron CPU. And although Gateway's cheapest portable is \$1,499, its Celeron-based processor is even slower.

Furthermore, the iBook is easily worth its price if, as the iMac has shown, burning technopassion can be slaked by a mere purchase. Apple's iBook is much more than just a portable iMac; it's a long list of surprising delights. And if first impressions prove to be true, the iBook may be the megabyte megahit that gives portable technology a jump start into the year 2000. ■

Contributing Editor DAVID POGUE (www.davidpogue.com) is the author of the upcoming *The iBook for Dummies* (IDG Books Worldwide, 1999).

01/01/00



Crash



Bomb



Disruption

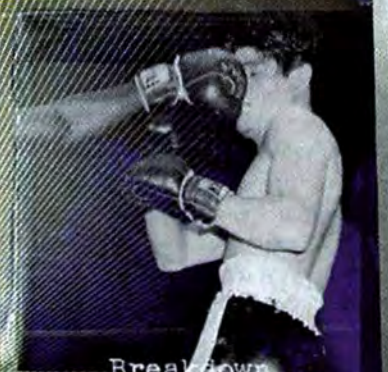

Breakdown

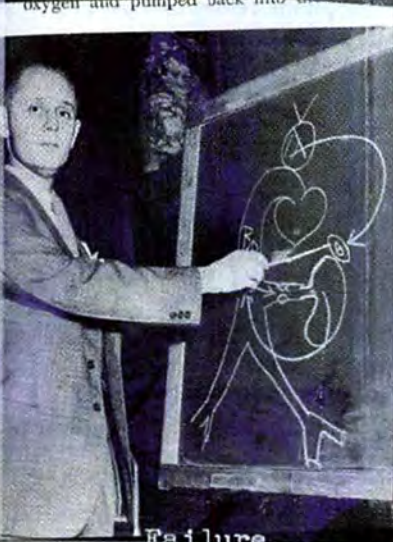

oxygen and pumped back into

Failure



Collapse



Hang

AT THE STROKE OF MIDNIGHT ON JANUARY 1, YOU WON'T HAVE TO WORRY ABOUT YOUR MAC

—OR WILL YOU?

UNLESS YOU'VE SPENT THE LAST FEW YEARS STRANDED on a desert island, chances are you've felt the wave of panic sweeping the world regarding computers and the year 2000. It seems like everyone is preparing for the day when computers *might* freeze or go haywire, as banks, hospitals, airports, and the PC empire frantically try to anticipate and forestall the damage the year 2000 may bring to businesses around the world.

The bottom line: at the stroke of midnight, January 1, 2000, some computers and other digital systems—such as ATMs, security equipment, communications services, power plants, and industrial automation—will stop working.

At their most basic, Y2K (yes, that's short for "year 2000") problems are simple to understand: if a system doesn't handle dates properly, it may become confused by years ending with "00." Systems that correctly handle dates past the year 2000 are considered Y2K-compliant.

In the real world, Y2K problems could range from the trivial to the catastrophic. Systems may invalidate credit cards, destroy records, shut down power grids, or assess decades' worth of late fees for that library book on your nightstand. And the damage might not stop there. Digital technology is a part of our everyday lives—it's in our coffee-makers, our cars, and even our telephones. As a result, assessing the *full* potential impact of the year 2000 is a daunting task. No one knows how widespread or significant these problems might be, especially on a global scale.

But forget about the globe. What about your *Macintosh*?

Your Mac and the Millennium

First, breathe a sigh of relief: even the oldest Macs can deal with dates from January 1, 1904, through February 6, 2040, so there's no fundamental year-2000 disaster lurking inside your Macintosh. If your computer is running system software released in the last decade—System 6.X through Mac OS 8.6—it can handle dates from 30,081 B.C. to A.D. 29,940. The BSD Unix that undergirds Apple's recently released Mac OS X Server supports dates through January 18, 2038.

And as for the year 2040, there's an interesting explanation behind Apple's odd expiration date. The original Mac development team chose midnight, January 1, 1904, as the start of the Mac calendar—in part because it's mathematically convenient to have a calendar system start on a leap year,

which 1900 was not. And since the calendar was built to cover approximately 136 years, your Mac OS won't expire until the start of the year 2040.

Because of all this, Apple's a bit smug about the Macintosh and the year 2000—the company even aired a commercial about Y2K during the 1999 Super Bowl. Apple has also assembled a sizable Y2K statement on its Web site (www.apple.com/about/year2000/), indicating which hardware components and operating systems the company has tested.

However, even though your Macintosh hardware and OS are ready for the year 2000, that doesn't mean your software—especially custom databases, macros, and spreadsheets—will function correctly once the new year arrives.

Of Errors and Expectations

Fundamentally, all Y2K problems stem from a computer system's inability to correctly process century information in dates. Some errors arise because the computers are dealing with incomplete date information, such as years expressed with only two digits. In such cases, computers must make assumptions about that information to use it at all. (See the sidebar "It Could Happen to You.")

Some programs may interpret dates differently than you'd like. If you enter a date in the format "1/31/00," a database program may read the date as January 31, 1900, even if the current date is well into the twenty-first century. Although this confusion can be annoying, technically you've entered a date with no century information—it might as easily refer to the year 1300 as the year 2000—and you have to hope your computer is smart enough to know which century you mean. However, that same program *would* have a Y2K problem if it misinterpreted a date *with* century information. If entering "1/31/2000" doesn't produce the intended result, you've got trouble. To avoid ambiguity, get into the habit of using four-digit years when entering dates to help isolate Y2K problems.

Safeguard Your Software

Even though the Mac OS doesn't have a problem interpreting far-reaching dates, that doesn't mean your soft-

BY GEOFF DUNCAN

ware will handle the year 2000. The fact is, not all programs were created to take advantage of the Mac's Y2K savvy.

Frequently, you'll find that applications used on the Macintosh may not be able to use the Mac's built-in date capabilities (see the sidebar "Proceed with Caution"). Similarly, your Mac OS programs may inherit date problems when you use files from other operating systems or those produced by programs with Y2K problems.

The most-common—and most-troublesome—Y2K concerns for Macintosh users are in customized software and scripts. Spreadsheets, databases, scripts, and macros built with everything from FileMaker Pro, Microsoft Excel, and AppleScript are all prime candidates for date-related snafus. It's not that these applications aren't ready for the new year (although some have isolated issues) but that certain folks who use them to build special formulas and macros may not know how to handle the year 2000 correctly. (See the sidebar "It Could Happen to You.")



Be Safe, Not Sorry

Before you panic, take comfort in the fact that you're using a Mac. Aside from some minor software tweaks, your faithful Mac should be ready to go when the big apple drops. But to be on the safe side, keep track of the versions of each application and any special features you've created, such as sorting formulas, spreadsheet macros, and scheduling shortcuts.

Satisfaction Guaranteed Just to be safe, check with the makers of all the software you use—from word processors and

graphics applications to accounting packages and backup programs—to see if the programs have been properly tested for the date change and if any problems were found. Most companies dedicate a section of their Web site to product-specific Y2K information (also see the sidebar "Proceed with Caution"). Generally, programs that manipulate date information, such as genealogy software and spreadsheets, are more liable to suffer Y2K mishaps than software such as an Adobe Photoshop filter that never considers dates.

If a program has problems, a corrected version may be available,

PROCEED WITH CAUTION

CHECK THE CURRENT Y2K STATUS OF ALL YOUR MAC APPLICATIONS

Your Mac may not have been bitten by the Y2K bug, but that doesn't mean that your files and documents are immune to Y2K corruption. Consult our application checklist to make sure your essential programs are ready to ring in the new year.*—RICH BARRON and www.macnologist.com

Company: Apple Computer
Product: Cyberdog
Version: 2.0

Problem: In e-mail messages and newsgroup postings, Cyberdog will use a three-digit year in the date header of outgoing messages after 1999.

Solution: Download a patch from www.cyberdog.org.

Company: CE Software
Product: QuickKeys
Version: Prior to 3.5.3

Problem: The Timer Options control panel displays years in two-digit format and does not correctly trigger events in 2000.
Solution: Download the free 3.5.3 update from www.cesoft.com.

Company: CE Software
Product: QuickMail Pro Client
Version: Prior to 1.5.4
Problem: Unknown.

Solution: Download a free update from www.cesoft.com.

Company: CE Software
Product: QuickMail Pro Server
Version: Prior to 1.1.1
Problem: Unknown.

Solution: Download a free update from www.cesoft.com.

Company: Claris
Product: Mailer
Version: 1.X

Problem: Starting January 1, 1999, the year 1999 is displayed as 1919 on incoming e-mail.

Solution: In Mailer's preferences, turn off Use Sender's Date/Time for received mail, or upgrade to version 2.X by contacting the original developer at www.fogcity.com.

Company: Connectix
Product: Virtual PC
Version: Prior to 2.1.1

Problem: The program cannot handle the leap year of 2000.

Solution: Download the free 2.1.1 update from www.connectix.com.

Company: DataViz
Product: MacLinkPlus Deluxe
Version: Prior to 10.1

Problem: No specific problem is stated, but the 10.1 update lists Y2K compliance as a new feature.

Solution: Download the free 10.1 update from www.dataviz.com.

Company: FileMaker
Product: FileMaker Pro
Version: Prior to 2.1

Problem: If a year in a date field is entered as two digits, the program assumes it's a twentieth-century date. More info is available at www.filemaker.com.

Solution: Manually convert two-digit years to four-digit years, or upgrade to FileMaker Pro 3.0v5 from the company's Web site.

Company: FileMaker

Product: FileMaker Pro
Version: Prior to 4.1v2

Problem: The TextToDate(date) calculation has been reported to register two-digit years as being in the 1900s.

Solution: Download the FileMaker Pro 4.1v2 English Updater to fix nonspecified Y2K date-handling issues (www.filemaker.com/about/year2000directory.html).

Company: Global Village
Product: GlobalFax
Version: Prior to 2.6.8

Problem: Users are unable to use the Send At feature to schedule faxes for years beyond 1999.

Solution: Download the free 2.6.8 update from www.globalvillage.com.

Company: Global Village
Product: Global Village or

PowerPort 56K PC Card Software

Version: Prior to 3.0.6

Problem: The Send At dialog box does not display dates that are ten years from the current date.

Solution: Download the free 3.0.6 update from www.globalvillage.com.

Company: Insignia Solutions
Product: SoftAT

Version: All versions

Problem: Each time the program is started in the year 2000, the date in the DOS and Windows 3.1 Date command is set back to April 1, 1980, and must be manually set ahead to the proper date.

Solution: There is no solution for this product. The user must upgrade to SoftWindows 98, SoftWindows 95 V.5, or RealPC 1.0, all of which run only on PowerPC-based Macs.

Company: Insignia Solutions
Product: SoftPC

Version: All versions

Problem: Each time the program is started in the year

* If a product is listed with "unknown" problems, this means the software has not been government certified as Y2K compliant, but does not necessarily mean that the version is flawed with Y2K errors.

TYPICALLY THE TRAUMA OF Y2K WON'T crash your system, but it may cause programs to behave oddly or present misleading information. A spreadsheet may calculate ages or durations incorrectly because it fails to use built-in date routines, or a database might sort or display information in unexpected ways, even if it's processing dates correctly.

Calculating the Problem Since a Y2K bug can creep up anywhere, we tracked a Microsoft Excel spreadsheet of a landscaping and horticultural business that operates a dozen vehicles and tracks mileage, depreciation, maintenance costs, and more. The owner's son created the original spreadsheet in the early 1990s, using Microsoft Excel 3.0 on a Mac SE.

We found that when the business acquires a vehicle with a model year greater than 1999, the age calculations will produce incorrect results, regardless of whether the years are entered in the two-digit ("00") or four-digit ("2000") format. In fact, because the owner's son didn't use Excel's

built-in data capabilities when he created the formula, this spreadsheet produces incorrect results for any four-digit year, before or after the year 2000.

Users with modest Excel experience can correct this formula, but spreadsheet calculations are intimidating and arcane to many people. One solution would be to rework the spreadsheet (under Format: Cells: Number) so that the program treats data in the Model Year column as dates and then to change the calculation so that it uses built-in date routines.

Dates Gotta Hurt Databases are also subject to Y2K mishaps and may even have Y2K problems that derive from organizational policy rather than computational error. For example, help-desk consultants at a community college in the state of Washington track technical-support incidents in a database, which assigns each incident a unique ID number.

The database creates the incident IDs with the ID number beginning with the last two digits of the year, followed by two-digit represen-

tations of the month and day. In 2000, the database will continue to assign correct ID codes, but how people use the ID numbers will create a Y2K glitch. When consultants start a shift, they search for incidents assigned to them, sorting so that important, recent incidents are listed first. Once the year 2000 begins, new incidents will sort to the bottom of the list instead of the top. Although it would be a trivial task to change the ID number format so that incidents sort correctly, the ID numbers are used by other departments, including one that employs a Web-based tracking system for internal billing. Any changes would have to be approved by several groups, entailing weeks of meetings and bureaucratic coordination.

One solution might be to investigate different ways to sort the database so that users see the results they expect without having to change the ID numbers; however, this may create additional problems for other database users.—GEOFF DUNCAN

2000, the date in the DOS and Windows 3.1 Date command is set back to April 1, 1980, and must be manually set ahead to the proper date.

Solution: There is no solution for this product. The user must upgrade to SoftWindows 98, SoftWindows 95 V.5, or RealPC 1.0, all of which run only on PowerPC-based Macs.

Company: Insignia Solutions
Product: SoftWindows
Version: 1.0.2 for 680X0 Macs; 1.0.3 for Performas; 3.0.3 for Power Macs
Problem: Each time the program is started in the year 2000, the date in the DOS and Windows 3.1 Date command is set back to April 1, 1980, and must be manually set ahead to the proper date.
Solution: There is no solution for this product. The user must upgrade to SoftWindows 98, SoftWindows 95 V.5, or RealPC 1.0, all of which run only on PowerPC-based Macs.

Company: Intuit
Product: QuickBooks and QuickBooks Pro
Version: Prior to 4 M12

Problem: A fatal system error will occur if you enter a post-2000 date in any field on or after January 1, 2000.
Solution: Update your software to version 4 M12 by October 31, 1999, because technical support for older, nonupdated versions of QuickBooks will not be available after this date. See www.intuit.com for more information.

Company: Intuit
Product: Quicken
Version: 98 prior to R5
Problem: While the program itself is compliant, online banking will not work past September 5, 1999.
Solution: Release 5 enables online-payment functionality for dates after September 5, 1999. Download the free update from www.intuit.com.

Company: Microsoft
Product: Excel
Version: 5.0
Problem: MS Query accepts two-digit years for an ODBC query but always assumes they're twentieth-century dates.
Solution: Always use four-

digit years for queries based upon date data.

Company: Microsoft
Product: Excel
Version: 98
Problem: Some wizards are available to watch over date input to keep it Y2K compliant.
Solution: Download the free updates from www.microsoft.com.

Company: Microsoft
Product: Outlook Express
Version: 4.0
Problem: Received messages that have a two-digit year in the date field are assumed to have been sent in the 1900s.
Solution: Upgrade to 4.01 from www.microsoft.com.

Company: Microsoft
Product: PowerPoint
Version: 4.0 through 4.0c
Problem: Opening PowerPoint 98 files in PowerPoint 4 for the Mac may cause two-digit years to display as "1XX" if the files were created after 1999 and you're using the Update Automatically date format.
Solution: Do not use two-digit years with the Update

Automatically feature, or resave PowerPoint 98 files as PowerPoint 4 files.

Company: Microsoft
Product: Word
Version: 6.XX
Problem: All two-digit shortcuts for dates are assumed to be in the twentieth century except for the year 00, which is interpreted as the year 2000. This can be seen when you use table date sorting, quote fields, custom document properties, and other higher-level date-handling functions but not when you use more-common functions such as inserting a date from a menu or using date fields.
Solution: See www.microsoft.com/support/ for more details and workarounds.

Company: Novell
Product: NetWare for Mac
Version: 3.12 or prior
Problem: Unknown; Novell will not test these versions.
Solution: Upgrade to version 3.2 or 4.2 from www.novell.com.

Company: Now Software/
Qualcomm

Product: Now Up-To-Date
Version: 2.1
Problem: This program displays the wrong year when printing events in the year 2000.
Solution: Upgrade to the fully compliant version, 3.6.5, from www.now.qualcomm.com.

Company: Pegasus Software
Product: Pegasus Mail
Version: 2.21
Problem: The program has a minor cosmetic defect that will not prevent normal day-to-day operation after the year 2000.
Solution: Upgrade to the next version when it becomes available at www.pegasus.usa.com.

Company: Prairie Group Software
Product: DiskTop
Version: 4.5.2
Problem: The program is not able to find files by date in the year 2000 or beyond.
Solution: Registered users will be notified of updates and upgrades.

List compiled by freelance writer RICH BARRON. For the most-up-to-date news about Y2K compliance, log onto www.macnologist.com/y2k/.



THE FINAL COUNTDOWN

THANKFULLY, OUR MACINTOSH hardware and operating systems are ready for the year 2000. But what about all those applications and files? Luckily, you won't have to leave the fate of your Mac to the Millennium Gods. In fact,

there are a few things you can do to prepare for the dreaded date.

It's a good idea to track the latest 2000 news and run periodic system checks; you can also safeguard your Mac by performing the following tasks. Remember, always back up your computer before beginning the following tests and make sure you have the latest updates to your software. These tips are especially important if you're running Linux—rather than the Mac OS—on your Mac.

Test Your Macintosh

Task 1 Turn off any automated backup software or schedulers. Since these tests involve changing dates on your Mac, it's possible that your computer will think past appointments should be deleted, browser cookies should expire, or the wrong files should be backed up. The safest way to run these tests is to work on duplicate test files and then throw away the duplicates when you're done.

Task 2 Open the Date & Time control panel and set it for 11:58 p.m., 12/31/99. Turn off your computer for at least three minutes. This will prompt the operating system to roll over to the year 2000 while your computer is turned off. If the transition is successful, reset the control panel to the above date and time and let the transition occur with the computer turned on. If the OS fails to roll over to the year 2000, you have an OS-level Y2K problem.

Task 3 With your Mac set in the next millennium, you can start looking for problem programs and data files. Test all of the date formats available with two-digit and four-digit years. Save and close files, and relaunch them. If possible, import, export, and run calculations on files with dates in short and long formats. Make sure that two-digit 1900 dates are not accepted as 2000 dates and vice versa. Sort the files to make sure that a year-2000 date is seen as more recent than a 1999 date. Also look through a copy of your actual data files for the same problems.

Task 4 Duplicate the previous tests with the following dates:

01/01/1999 Some applications start having date-related problems a year earlier than expected.

09/09/1999 If the date is shortened to 9999, it could cause problems with some files or applications.

12/31/1999 "Tomorrow" should be seen as 01/01/2000 in all applications that use dates.

01/01/2000 The year 2000 should follow 1999.

02/29/2000 The year 2000 is a leap year. Make sure applications don't roll over to 03/01/2000 from 02/28/2000.

01/01/2001 Some applications might misbehave in 2001 and beyond.

Task 5 Upon completion, set the date back to the present time, enable any disabled software, and trash your test files. Keep a watchful eye for any problems that testing may have introduced.—RICH BARRON

but it's probably the most recent release with an upgrade fee. And those of you who own older Macs may find that some new versions are available only for PowerPC-based Macs or that the software requires more RAM or disk space than your current Macintosh can provide.

With older programs, you may find that although the software has known Y2K problems, the company is out of business or no longer supports the product. Again, if you can't work around it, you'll have to switch to another program.

Unavoidable Irks If you use customized databases, scripts, or macros, you need to figure out how they'll handle the year 2000. There are some general Y2K testing procedures (outlined in the sidebar "The Final Countdown") that can help you start troubleshooting. Otherwise, contact the original creator (whether that's a consultant, a shareware author, or someone down the hall) to see if they've reviewed the program for any snags or problems.

The Last Word

Don't let this article fill you with trepidation: the Macintosh is remarkably well prepared for the year 2000, and the vast majority of Mac programs won't have difficulty making the transition to the new year. However, the Mac has no special immunity to the potential crisis ahead and you shouldn't ignore the threat of Y2K incompatibilities. The best preparation you can do is to run our recommended tests on your Mac; check out your software's Y2K status; and then sit back, relax, and grab that bottle of bubbly from the fridge. Your Mac will still be with you next year. **m**

Freelance consultant GEOFF DUNCAN is the technical editor for the online newsletter TidBits (www.tidbits.com). He expects his phone will ring nonstop during January 2000.

GOOD TO GO

These products have no known Y2K problems. Check each company's Web site for the latest information.—RICH BARRON

Company: Adobe Systems

Web site: www.adobe.com

Illustrator 6.0 and later
PageMaker 6.5 and later
PageMill 2.0 and later
Photoshop 4.0 and later

Company: Aladdin Systems

Web site: www.aladdinsys.com

Stuffit Expander 4.0 and later

Company: Apple Computer

Web site: www.apple.com

AppleWorks 5.0 and later
ClarisWorks 5.0 and later

Company: Dantz

Web site: www.dantz.com

Retrospect: All versions

Company: Dr. Solomon's Software

Web site: www.dr Solomon.com

Virex: All versions

Company: Macromedia

Web site: www.macromedia.com

Director 6.5 and later
FreeHand 8.01 and later

Company: MicroMat

Web site: www.micromat.com

TechTool Pro 2.0 and later

Company: Netscape

Web site: www.netscape.com

Navigator 2.02 and later

Company: Quark

Web site: www.quark.com

XPress 3.32 and later

Company: Symantec

Web site: www.symantec.com

Norton Antivirus 5.0 and later
Norton Utilities 3.5.1 and later



Simply fun

Simply creative

Simply educational

Simply great for business



Simply Macworld EXPO

The Face of Things to Come

MACWORLD Expo/San Francisco

Conference: January 4-8, 2000

Exhibits: January 5-8, 2000

www.macworldexpo.com

800-645-EXPO

Sponsored by:
Macworld
MacWEEK.com
MacBuy.com

Managed by:
IDG
EVENT MANAGEMENT
COMPANY

Yes! Please send me more information on
MACWORLD Expo/San Francisco!

MCW

I'm interested in:

Attending Exhibiting

Name _____

Title _____

Company _____

Address _____

City/State/Zip _____

Phone _____ Fax _____

Email _____

(if you would like to receive information via email about MACWORLD Expo)

Mail to: MACWORLD Expo, 1400 Providence Highway,
PO Box 9127, Norwood, MA 02062. Or Fax to: 781.440.0357

THIS IS NOT A REGISTRATION FORM.

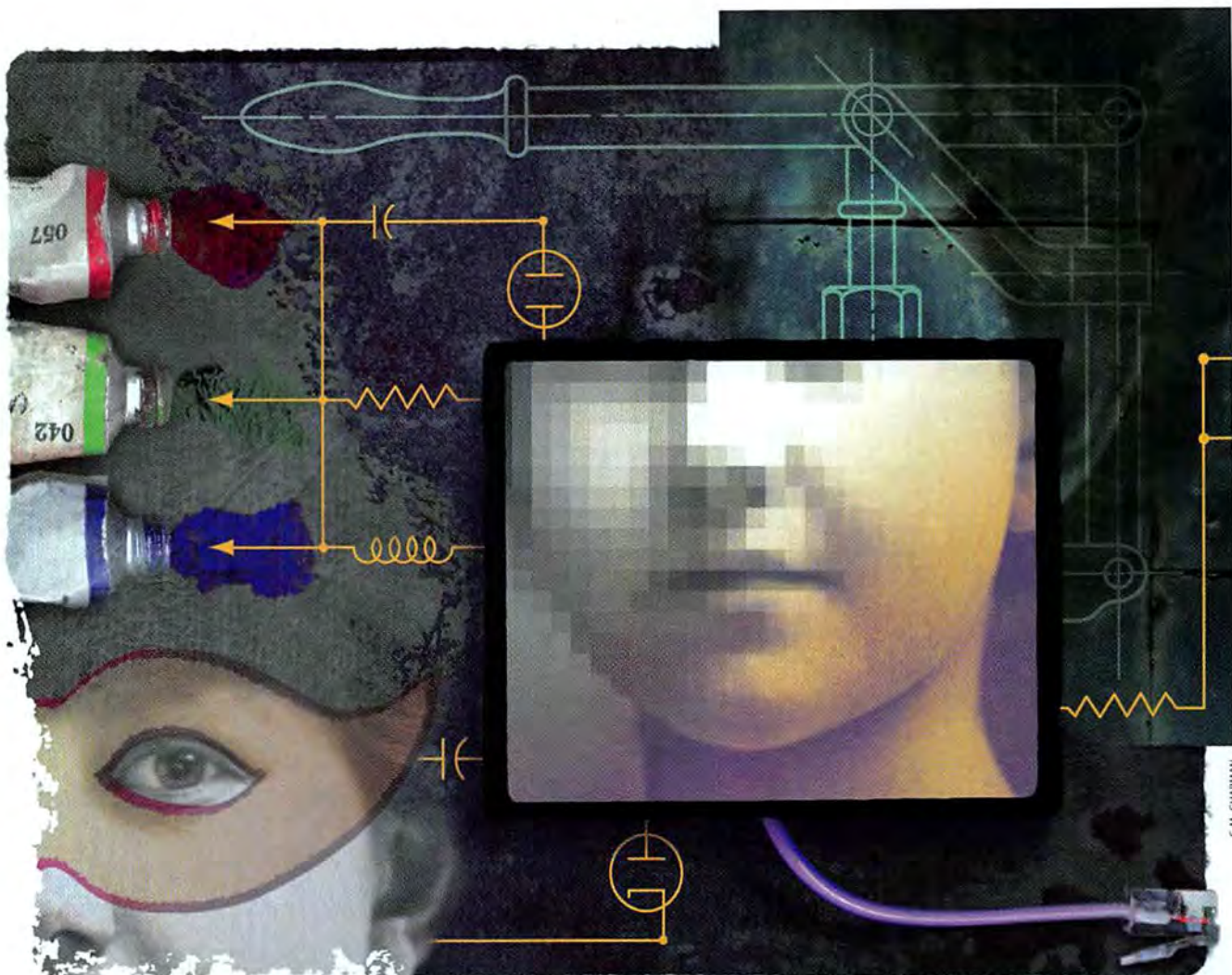

CAM CHAPMAN

When it comes to the Web, Adobe Photoshop has always been a program fraught with contradictions. It's probably the most popular tool used by people in the Web-design and -graphics businesses, whether it's to shape images for the Web or to sketch out a Web-site design before implementing it in HTML code. Despite all that, the flagship product of Adobe Systems (800/492-3623, www.adobe.com) has never been particularly Internet-savvy—a situation that has led to the creation of a whole industry based on plug-ins and programs that perform the vital jobs that Photoshop simply doesn't do.

But as of version 5.5, Photoshop has finally embraced the Web. Sure, this \$129 upgrade for owners of Photoshop

5.0 or ImageReady 1.0 (\$610 for new buyers)—which will be available by the time you read this—adds some features that will be attractive to Photoshop's traditional-print fans (see the sidebar "Not Just for the Web"), but the bulk of the changes to the venerable image editor are meant to satisfy the long-suffering Web-graphics community.

How'd they do it? Basically, Adobe rolled in most of the features found in the Web-graphics product the company released last year—Adobe ImageReady. In a move that shows both how far Web design has come and what a misstep leaving Web features out of Photoshop proved to be, Adobe will now make ImageReady available *only* as part of the Photoshop 5.5 package.

A new version of this program, ImageReady 2.0, will be bundled with Photoshop. It handles higher-end tasks, such as Web animation, and other fancy

techniques, such as using JavaScript rollovers and image slicing.

Window to the Web

With Web graphics, you've always got to walk a tightrope between creating high-quality images and making ones that download quickly over slow modem lines. Web designers work primarily with JPEG files (for photographs) and GIF files (for text, logos, and other graphics with large blocks of solid color). Careful tweaking makes all the difference with images saved in either of these formats. The more control designers have when making trade-offs between beauty and speed, the better.

Until this newest version, Photoshop lacked that control, so most designers instead used Photoshop plug-ins, such as

BY JASON SNELL

Photoshop *D*iscovers the Web

WITH VERSION 5.5,
ADOBE'S IMAGE EDITOR
FINALLY GETS
INTERNET-SAVVY

the \$50 ProJPEG and \$70 PhotoGIF from BoxTop Software (662/263-5410, www.boxtopsoft.com), or programs such as ImageReady and the \$199 Fireworks 2.0 from Macromedia (800/457-1774, www.macromedia.com). These tools allowed designers to manipulate the file size and quality of JPEG and GIF images, with immediate visual feedback. However, none of them are able to match Photoshop's all-powerful image-editing features. As a result, prepping graphics for the Web often involves constant switching between Photoshop and a Web-savvy application.

The biggest addition to Photoshop 5.5 is the Save For Web menu item, located on the File menu. Choosing Save For Web doesn't bring up the usual Save dialog box; instead, a large window appears that lets you modify your image in various important ways. This won't be exotic to anyone who has used Macro-

media's Fireworks (see the screen shots, "Separated at Birth"), which offers an almost identical interface. ImageReady 2.0 also has this feature.

JPEG Mojo In the Save For Web window, you can scale the level of quality (from 0 to 100) for files in the JPEG format. As you move the Quality slider toward 0, you'll see the quality of your image drop—the more compressed a JPEG becomes, the more blocky image artifacts you'll see—but in the lower left corner of the window, you'll see its file size drop as well. By clicking on the window's 2-Up or 4-Up tabs, which let you compare two or four versions of your image (with different JPEG and/or GIF options selected) in the same window, you can quickly compare different settings.

GIF Control Some of Photoshop's best new features involve perfecting GIF images. Unlike JPEG files, which

use millions of colors, GIF images are limited to a palette of only 256. In order to make a GIF look good, then, you need to pick the right colors for the job. Photoshop 5.5 gives you an impressive amount of control over GIF images' characteristics.

As in ImageReady 1.0, Photoshop's Save For Web window lets you see and control all the colors in a GIF image's palette. By cleverly controlling the palette of a GIF file, you can dramatically reduce the file size. The first thing Photoshop must do is take your source image and throw away all but 256 of its colors. To make this easier, the program lets you choose from a series of preset palettes, including not only a "Web-safe" palette but also an Adaptive palette, optimized for the colors that appear most often in the image, and a Perceptual palette, weighted toward the colors in the



Photoshop *D*iscovers the Web

image that the eye notices most.

Although choosing one of these palettes is a good shortcut to creating a fairly small, good-looking GIF file, perfectionists will want to make even more changes. After all, just because you *can* have as many as 256 colors doesn't mean it's a good idea. The fewer colors you have, the smaller the file size of the image and the shorter its downloading time.

One option in the Save For Web window helps you slim down your colors by

but it can also make a deathly boring one. One way to approximate a more expansive variety of colors is through *dithering*—simulating a color by placing dots of two other colors close together so that from a distance, they appear to be a third color.

Photoshop 5.5 offers three different dithering effects. It also allows you to set a dithering percentage, so you can vary the amount of dithering in your image and see how it affects image quality and file size. Although it's nice to have these options, avoid using dithering if you can. It usually increases file size.

For the ultimate in color control, Photoshop lets you edit the GIF color palette. This is a powerful and quite useful feature, allowing you to *lock* colors that you don't want to change under any circumstance (for example, the colors in a company's logo). You can also select individual colors and shift them to their nearest Web-safe equivalent (so they won't dither, even on a monitor that can display only 256 colors), or delete colors one by one from the palette to simplify your images and reduce their file sizes.

One Innovation The features in the Save For Web window are new to Photoshop, but it's only fair to point out that they're not new altogether—most of them will be familiar to users of ImageReady or Fireworks. There is one unique feature offered for the first time in Photoshop 5.5: the *lossy GIF*.

Adobe's lossy-GIF algorithm cleverly exploits the way that GIF images are compressed, by taking large areas of a single color and describing them in shorthand, rather than pixel by pixel. This lets it create a lower-quality image with a smaller file size. As you increase the lossy compression, you'll start to see distortions, including 1-pixel-high horizontal streaks across your image, but you may not mind when you're in a pinch.

Photoshop's New Pal

Artfully exporting files in the GIF or JPEG format is far from the be-all and end-all of Web-graphics production.

There are several Web-specific features of vital importance to Web-graphics professionals that don't appear in Photoshop 5.5. Instead, those features are a part of the much improved ImageReady 2.0.

Tight Integration Although Photoshop and ImageReady are clearly meant to work together, they've also been developed to work successfully apart. Many users used to grumble about ImageReady's lack of image-editing tools, such as the rubber stamp and the airbrush—features that were available in its competitor Fireworks. If you were among those people, you'll be happy to see the program's more comprehensive set of image-editing tools. Even though everyone who owns ImageReady 2.0 will now automatically have Photoshop too, these tools will save you from toggling back and forth between the two programs just to do minor touch-ups.

For those times when you must toggle, switching between the two applications is now a much easier task too: both fully understand the Photoshop file format, and clicking on a button at the bottom of each program's tool palette opens the currently active document in the other program.

Slicing and Dicing Most Photoshop users don't spend a lot of time taking the images they've carefully created and cutting them up into little bits. Yet the practice of *slicing* an image is quite common on the Web, since one giant image is less efficient in table-based HTML layouts and JavaScript-laden interactive designs than the same image cut into sections.

In version 2.0, ImageReady matches the slicing versatility of Fireworks 2.0: you can select areas to be sliced up, either by dragging guides out from a ruler or by choosing the Slice tool and drawing a rectangle over a particular area. You can choose a different GIF and JPEG setting for each slice. This is particularly useful if you've designed a Web page as a graphic and distinct parts of it (say, the photograph in one corner and the text in the other) require different compression methods.

Simple JavaScript You'd think that creating graphics and wading into the world of HTML coding would be two separate jobs. But with so many of the bells and whistles on Web pages being the result of JavaScript *rollovers*, images that change when you move your mouse over them, it makes sense that ImageReady includes some HTML-related features.

You can still separate the jobs—a Photoshop user can create a big image or



Separated at Birth

Many of Photoshop 5.5's new features will look very familiar to Macromedia Fireworks users. For example, the new Save For Web window (top) offers features also available in Fireworks' similar Expert Preview window (bottom), such as the ability to compare up to four versions of an image with different compression schemes.

directly controlling the number in your GIF image. We took a sample image with 204 colors and knocked it down to 64 colors. In the process, the image's size fell from 15.3K to only 9.3K.

Palette Power A limited color palette may make a faster-downloading image file,

Quick-'n'-Easier Masking

Whether you're working on images destined for the Web or for print, selecting exactly what you want is never easy. Fortunately, Photoshop 5.5 offers tools that at least make it easier. One of these is the new Extract feature. What makes Extract truly special is that it

performs *color decontamination* (removes the strange halo) along the edge of your selection. This is important because the success of any selection is based entirely on the transition between what is selected and what is not. A lousy transition means that you get some of the original background along

with the object you actually want. This line along the edge of an object is a dead giveaway it came from somewhere else.

Note that the Extract feature doesn't make a mask. Rather, because it needs to remove the background color from edge pixels, it actually deletes the back-

ground. This is unfortunate because using Extract rarely results in a perfect selection and you'll need to do some fine-tuning. For this reason, it's a good idea to duplicate your layer before using Extract. Again, no one ever said it was going to be easy. Just easier.—DAVID BLATNER

1

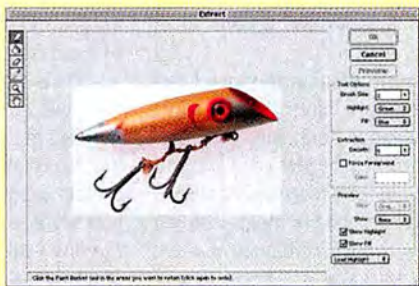

When you select Extract from the Image menu, the Extract dialog box appears, containing a proxy of your image that you can work on.

2

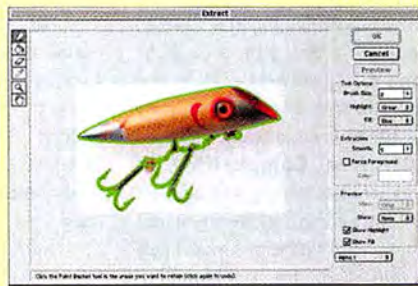

Use the brush tool to paint along the edge of the object you're trying to select. The default color of this "paint" is green, but you can change it to red or blue if your image has a lot of green in it. If you make a mistake, you can erase some of the "paint" with the eraser tool.

3

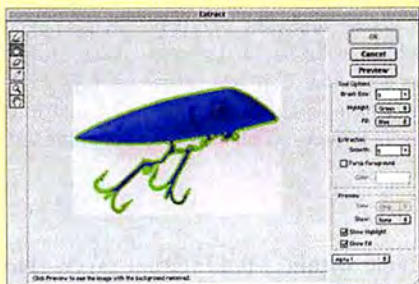

After specifying the edge of the selection, click on the object with the paint bucket tool. This tells Photoshop which side of the green line is the inside—the object itself.

4

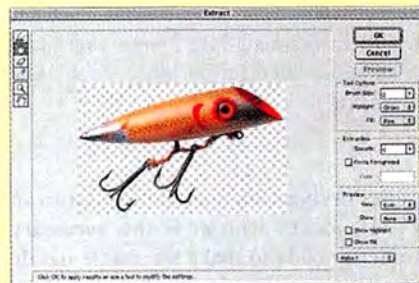

Click on Preview to see the extracted object on top of a transparent background. If you like what you see, click on OK. If not, you can make further adjustments to your edge with the brush tool or adjust other settings in the dialog box and preview the extraction again.

Voilà!



In the end, you'll get noticeably better results with less effort. Traditional selection methods, such as using the magic wand, can pick up edge spill and often result in a sharper, less realistic edge (see the example at right). The Extract feature removes the background color from edge pixels, leaving a semitransparent edge, which makes the foreground object blend more smoothly into whatever new background you choose.

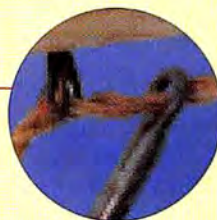

Results with the Extract feature



Results with the magic wand



Not Just for the Web

Although the Web publishers of the world have reason to rejoice at the release

of Photoshop 5.5, the rest of us—the mere mortals who still have to make a living based on print publishing—can quietly cheer at several features in this upgrade that may make our days easier too.

Carefree Compositing If you do any *photocompositing* (cutting an image out and putting it into another), your nemesis is most likely *edge spill*, where the background of the original image appears as a gritty halo around the composited graphic. Now to the rescue come the new Extract feature and the Background Eraser tool. Both erase pixels relatively intelligently, but, more important, both perform edge-color decontamination—they carefully remove the background color from pixels at the cut-out object's edge.

Where the Extract feature deletes the background color all at once (see the sidebar "Quick-'n'-Easier Masking"), the Background Eraser tool lets you paint away (or erase) the background in a smooth, intelligent way until it becomes transparent. Unfortunately, neither tool works particularly well with really tricky images that contain, for example, breezy blond hair against a sunny golden beach.

Another compositing tool, the magic eraser, gets essentially the same results as using the paint bucket tool with a "clear" fill instead of a color. However, it's too blunt an instrument to be particularly helpful for anything but very rough, first-draft work.

Ultimately, although these new features are powerful, they don't obviate the need for additional masking plug-ins, available from companies such as Ultimatte, Extensis, and Human Software. These still offer features above and beyond Photoshop's, including help in building clipping paths.

Better Text Adobe blundered with its type control in Photoshop 5.0, especially in the rasterizing of

small text (which looked terrible). Several features in version 5.5 help fix these problems. Three levels of antialiasing and the option of using fractional widths (most letters aren't an even number of pixels wide) help you set good-looking type at all sizes. Less exciting, but still useful, is the ability to fake bold, underlined, and italic text. Note that if you don't upgrade, Photoshop 5.0 will be able to read type layers that are created in version 5.5 but will ignore all of the new features.

Simple Pleasures Sometimes it's the simple things that are most likely to get an "ooh-aah" response. And this may be the case for you when you open the Automate submenu (under the File menu) and see the new macros contained therein. Picture Package is a boon to any photographer tired of duplicating, rotating, and scaling photos in order to fit several versions of the same picture onto one sheet of film (for instance, when you're creating school photos, where you want a certain number to be wallet-size, and so on).

Similarly, the Contact Sheet feature—which gangs up thumbnail images on a page—contains new

options, such as the ability to add file names under a thumbnail and include all the images in nested folders.

If you're not the type to muck about with HTML code and need to get photos on the Web quickly, you'll also appreciate the Web Gallery feature. Select a folder of photos, and Photoshop will automatically convert them to the JPEG file format and generate HTML pages with links between these images and small thumbnail versions of them that it also creates.

One-Minute Monet In a nod toward fine artists, Adobe has included the Art History Brush, which lets you create various impressionistic effects simply by brushing it over your images. Unfortunately, the artsy options—with names such as Tight Short, Dab, and Loose Curl—are a far cry from what you can create in MetaCreations' Painter. With luck, future versions of Photoshop will expand on this tool.

Clearly, the majority of features in this upgrade are oriented toward Web professionals. But there are a few gems that might be just enough to tempt the rest of us to upgrade too.—DAVID BLATNER

a series of sliced-up ones and send it to an HTML jockey who adds the necessary JavaScript code to make the razzle-dazzle happen. ImageReady 2.0, however, can also generate all the necessary HTML magic by itself. From within ImageReady, you can set up rollovers (even images that change in one place when you move your mouse over a *different* place), and the program will generate an HTML file.

This is a feature that Fireworks 2.0 offers too, and as you might expect, compatibility is an issue. Rollovers generated in ImageReady work well in Adobe GoLive, but they may not in Macromedia Dreamweaver. Rollovers from Fireworks, on the other hand, work in Macromedia Dreamweaver *and* GoLive if you download a template from Macromedia's Web site that lets Fireworks export HTML in the GoLive style.

Jumping GIFs In the past, Photoshop users had to resort to shareware programs such as Yves Piguët's free GIFBuilder to create GIF animations, usually after

painfully generating each frame within Photoshop. The arrival of ImageReady and Fireworks changed that by adding robust animation tools. ImageReady 2.0 carries on that tradition, matching Fireworks 2.0 at every step.

You can create animated GIFs by using ImageReady's Animation palette, moving layers (or switching them on and off) to achieve animated effects. For those of us who are too lazy to move items through a series of steps to get the final animated effect we seek, there's ImageReady's Tween command, which uses the information in "before" and "after" frames (for example, a red ball at the bottom of the screen and at the top) to figure out and create what would come in between.

The Last Word

The arrival of Adobe Photoshop 5.5 may mark a major milestone in the world of Web graphics, or it may just be a bump in the road. After years of ignoring the Web, Photoshop has finally got-

ten Internet-savvy—but is it too late?

Macromedia's competing product, Fireworks 2.0, is powerful and popular. Although its mix of drawing-program and Photoshop-like abilities makes it harder for many people to learn, it also gives the program unique strengths (see *Reviews*, July 1999). It's also tightly integrated with Dreamweaver—an HTML editor that seems to have a lot of momentum, at least for now. On the other hand, if Photoshop and ImageReady can provide most of Fireworks' features in one package *with one price tag*, Adobe may have a major advantage.

Regardless of who wins this battle, one fact can't be denied: Web pros who use Photoshop finally won't have to pay extra to get the basic tools they need. It's been a long time coming, but Photoshop has finally embraced the Web. **m**

Senior Editor JASON SNELL has been writing about Web publishing exactly as long as he's been doing it—since 1993.

"Forget the Oscars, here come the Webbies."

- The New York Times, January 7, 1999

Call for Entries

The International Academy of Digital Arts & Sciences™ invites
you to submit your Web site for The 4th Annual Webby Awards®

www.webbyawards.com

Honoring the Best of The Web In 24 Categories:

Activism, Arts, Community, Commerce, Education,
Fashion, Film, Finance, Games, Health, Humor, Living, Music,
News, Personal Web Site, Politics & Law, Print & Zines, Radio,
Science, Sports, Technical Achievement, TV, Travel, Weird

Deadline: September 16, 1999



An IDG Event

we also walk dogs

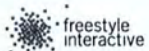

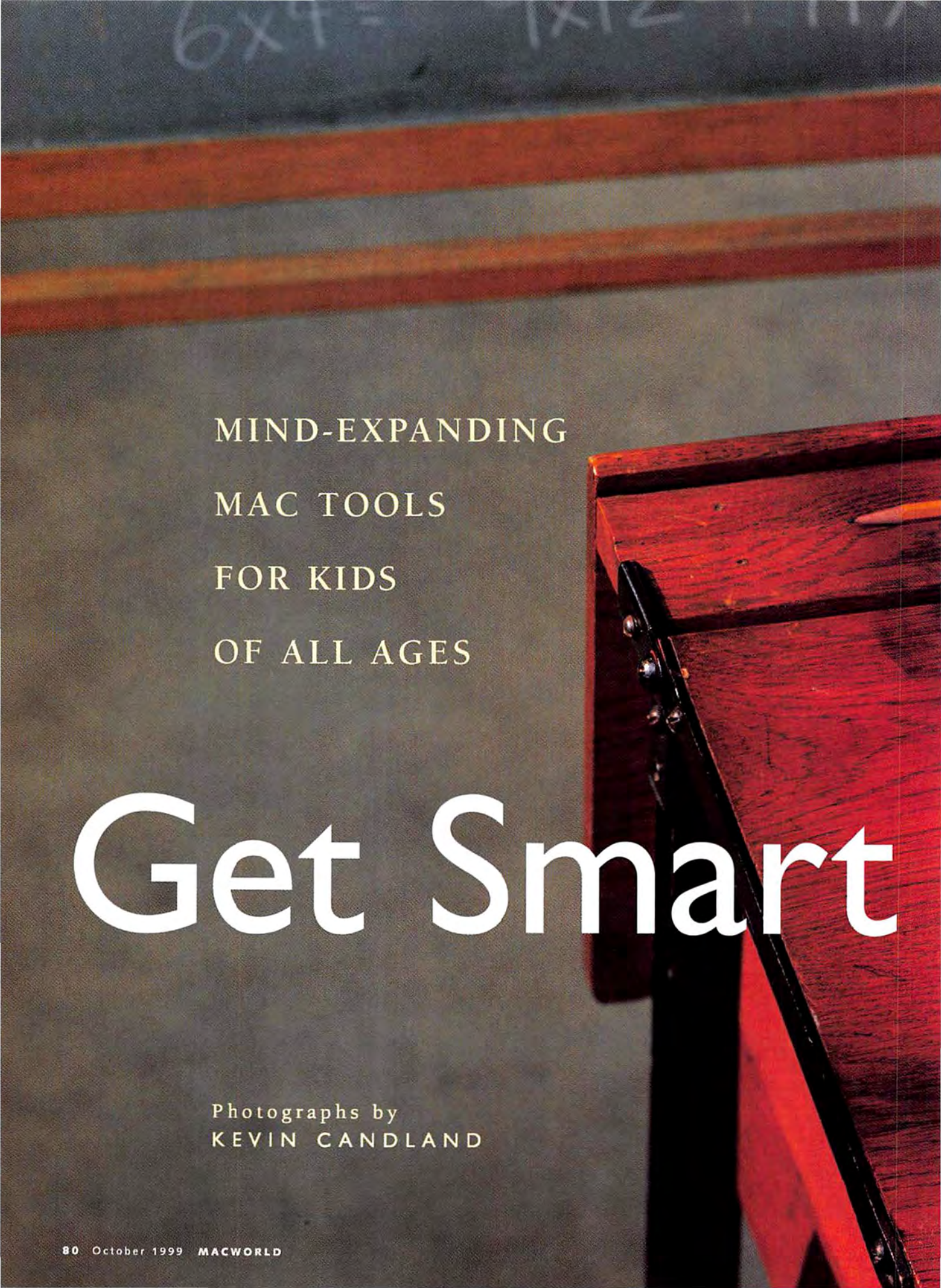
A chalkboard with faint math equations like "6x4=" and "1x12=" is visible at the top. Below it is a wooden desk with a pencil and a black object, possibly a stapler or a clip, resting on it.

MIND-EXPANDING
MAC TOOLS
FOR KIDS
OF ALL AGES

Get Smart

Photographs by
KEVIN CANDLAND

A good work!



It's that time of year again. Time to pack away the beach towels and put those sandy bottles of sunscreen on the back shelf. That's right, summer is over and school is back in session.

But school isn't the only institution of learning available to your family. There's a cornucopia of software that can turn your trusty Macintosh into a world-class teaching tool. Whether you're teaching your child how to identify colors or preparing for the SAT exam, there's a Mac program out there that can help.

And perhaps the greatest news about education software is that most of these programs don't demand the kind of processing power, hard-disk space, and RAM required by most other kinds of software—great news for parents or starving college students on a limited budget.

With so many learning tools to choose from, finding the best educational programs for your child can be frustrating. That's why we've teamed up former teachers, parents, and youthful scholars to test and rate nearly 30 of the most notable education programs out there. Now pay attention, class.



EARLY LEARNERS

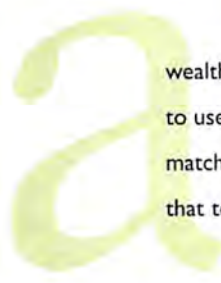

wealth of software is being released for tykes, proving you're never too young to learn or to use a Mac. Preschoolers can learn from software that focuses on basic concepts such as matching, sorting, and pattern recognition, and older children can benefit from programs that teach reading and thinking skills.

Teaching Tots

Even the very youngest pupils—ages two-and-a-half to four—can, with the proper software and supervision, get a head start on learning with a Mac. Although these sprouts have neither the patience nor the acumen for advanced math and phonics drills, they can learn from games that test their ability to count as well as recognize, sort, and match shapes and colors.

Many parents may have had enough of Nickelodeon's Blue's Clues franchise, but kids seem to love this omnipresent pup. That's just one reason to look into Blue's 1-2-3 Time Activities (♦♦♦♦; \$20), from Humongous Entertainment (800/499-8386, www.humongous.com)—the other is the educational and entertaining set of activities designed to help children with their counting and matching skills.

Blue's 1-2-3 Time Activities takes place at a backyard fair where your child and the blue canine can participate in seven games, including Mother May I?, which teaches the basics of addition and subtraction, and the Pattern Parade, which asks kids to recognize patterns of shapes and fill in the missing pieces. Whenever Blue succeeds, she earns one or more Blue Dollars that can be used to purchase pieces of a puzzle. Blue's 1-2-3 Time Activities is a well-thought-out package that kids will play again and again.

Not so successful is the Dally Doo 2 series (♦♦; \$13), from Arc Media (416/410-4429, www.arcmedia.com). Not only are these programs' graphics and animation primitive but the authors also appear to have only limited experience with children's education. These discs—covering such topics as animals, colors, numbers, and shapes—are aimed at three- to six-year-olds yet include references to Sherlock Holmes and other characters and concepts that are likely to be foreign to young

children. And during a shape-recognition exercise, a sharpened, five-sided pencil is identified as a rectangle. Worse, incorrect answers are met with a jarring honk—hardly the kind of gentle correction that will encourage children to try again.

Aboard the Reading Railroad

Reading programs are among the most popular Mac applications for kids. All parents want their child to read, after all, but teaching reading properly can be daunting. We examined four

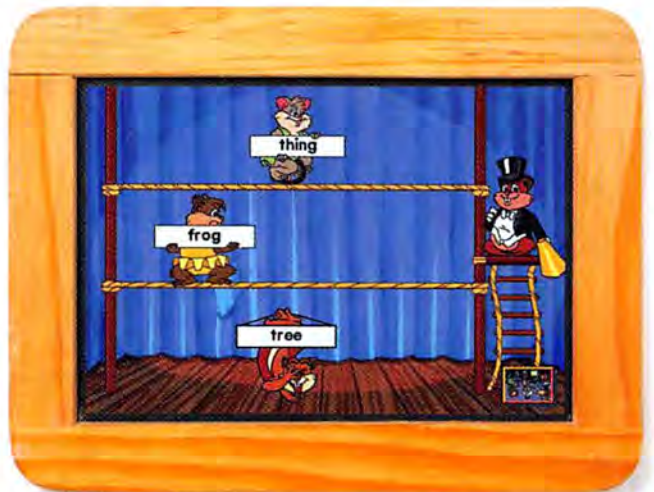

Rodent Rivals Pick the correct word in Reader Rabbit's Complete Learn to Read System, and your rodent might win the race.



packages that offer varying degrees of reading instruction—Dr. Seuss Reading Games (●●●; \$20) and Arthur's Reading Games (●●●½; \$20), from Creative Wonders, a division of The Learning Company (800/716-8506, www.learningco.com); Let's Go Read 2 (●●●½; \$45), from Edmark (800/691-2986, www.edmark.com); and Reader Rabbit's Complete Learn to Read System (●●●●; \$70), from The Learning Company.

Arthur's Reading Games and Dr. Seuss Reading Games focus on word recognition, although the Dr. Seuss's ABCs component of the latter coaches kids in letter recognition as well. The Dr. Seuss CD is essentially an interactive, "click on an object and see what happens" version of Seuss's *Cat in the Hat*—entertaining, but lacking a strong instructional component. Arthur's Reading Games focuses more on reading, with two word-recognition games and an activity that helps children learn about sentence structure. Although children will likely learn to recognize certain words through repeated playing of these two amusing, interactive products, they won't absorb the basics of phonics from these discs.

Let's Go Read 2 and Reader Rabbit's Complete Learn to Read System may not be quite as much fun as the reading-games titles, but the teaching elements are far stronger. Both programs coach children on vowel and consonant sounds, help them sound out words, and bolster their vocabulary with new words. Although both are solid programs, Reader Rabbit is more comprehensive, thanks to the bundled material you and your child can use away from the Mac—flash cards, storybooks, and a workbook for practicing reading activities. Let's Go Read 2 teaches the basics of phonics as well as Reader Rabbit does, but portions rely on a speech-recognition system that works only sporadically. Children may quickly become frustrated when the computer ignores their spoken answers.

Think Smart

Designing educational software for several age groups—say, for preschool through junior high—is tricky. If the activities are too difficult, younger children will become frustrated; make the graphics too juvenile or the tasks too simple, and older children will say it's for babies. For the most part, Edmark (800/691-2986, www.edmark.com) manages to strike a nice balance in its Thinkin' Things series, which includes Toony the Loon's Lagoon (●●●●½; \$30) and All Around FripplieTown (●●●●½; \$30).

Although the Thinkin' Things series features charming characters and animation, there's little fluff here—the people who put these programs together seem to understand the way children learn. For example, if a child continues to perform tasks correctly, the program automatically increases the difficulty of subsequent tasks, skipping repetitive interim exercises. Conversely, if a child appears to be having difficulty, the program won't present tougher tasks until that child reaches a rea-



Loony Tune Toony the Loon is your host for this call-and-response music activity from Toony the Loon's Lagoon.

sonable level of success. And most of the Thinkin' Things activities allow two levels of involvement: kids can just play at an activity or actually solve particular problems.

Toony the Loon's Lagoon and All Around FripplieTown are designed for children ages four through eight. Toony helps children with their memory and listening skills through "Simon says"—style auditory games—a character plays a pattern of sounds, and your child is asked to repeat that pattern. For a greater challenge, children can switch off visual clues and repeat the pattern based mostly on the tones they hear. In another activity, children compare and contrast objects (cartoon characters called Fripplies), using such factors as color, pattern, and hairstyle. All Around FripplieTown is just as delightful and helps with navigation skills, number sequences, and problem solving. Particularly engaging is the Fripplie Cookies activity, where your child must determine the steps Bob and Gaston—two residents of FripplieTown—took to create their sugary creations. Those steps might include rotating and flipping a cookie, applying excessive heat to one side, and taking a large bite out of it—a fun and useful lesson in deductive reasoning that kids are sure to enjoy.





HOMWORK HELPERS

S

choolwork, birthday parties, soccer practice . . . some grade-schoolers' schedules would make a CEO cringe. So it's important to choose educational programs that make the most of children's limited time at the computer. Read on to find our nominees for the back-to-school software honor roll, as well as for some programs that could use some extra help.

Ho-hum History Lessons

In *Discover More History* (♦♦♦½; \$10), from Arc Media (416/410-4429, www.arcmedia.com), history buffs who are over age nine can take a magical elevator to 12 floors. Each of the stops features various objects; when the player clicks on one, a written summary of a historical event appears and is spoken. After exploring a floor, the budding historian must answer a multiple-choice question to get permission to ascend to the next floor. Unfortunately, the historical descriptions, although well written, often don't relate to the scene. And the lack of creativity and the monotonous game play are enough to make any eighth grader anxious to return to the classroom. (Alas, Arc Media's other titles in the same series—covering math, science, and geography—aren't any better.)

Frankie Goes to School

With Frankie the dog as their faithful companion, first graders will love *JumpStart 1st Grade* (♦♦♦½; \$30), from Knowledge Adventure (800/545-7677, www.knowledgeadventure.com). And since this popular series includes titles for kids as young as nine months, it's never too early to become a fan of Frankie the dog. All the basic learning building blocks are packed into 12 areas, including math, time telling, language, and art. As in the other games in the *JumpStart* series, Frankie hosts all the fun in and around a colorful schoolhouse (see "Spare Change"). Although most youngsters will enjoy Frankie's lessons, some of the activities may be too difficult for five- and six-year-olds.



Spare Change An animated vending machine in *JumpStart 1st Grade's* lunchroom helps kids learn how to use and count change.



Pound the Keys Like a Pro

Back in the old days, typing lessons included a rickety typewriter and a tired instructor. But the typewriters have retired and the new typing tool is *All-Star Typing* (♦♦♦; \$30), from The Learning Company (800/716-8506, www.learningco.com). This handy Mac program teaches keyboard techniques, using a series of drills with a basketball theme. Although it's intended for kids from 9 to 12 years of age, keyboard-challenged parents might also want to give *All-Star Typing* a go.

Puzzling Puzzles

The Thinkin' Things series' *Galactic Brain Benders* (♦♦♦♦; \$30) and *Sky Island Mysteries* (♦♦♦½; \$30), from Edmark (800/691-2986, www.edmark.com), abandon some of the more childish themes in deference to their older 8-to-12-year-old audience. For example, *Galactic Brain Benders* helps teach early programming skills by asking children to string together sets of rules to force a particular action, such as creating the field patterns of

a marching band. The program also allows children to experiment with the rules of physics by creating ramps and slick surfaces on a virtual metal table and then rolling marbles about the surface by changing the tilt of the table.

In *Sky Island Mysteries*, your child becomes the family sleuth by helping investigator Joe Cluesoe solve problems on three floating islands. Like *Galactic Brain Benders*, *Sky Island Mysteries* helps kids learn to master a situation—managing an air show, for example—by following rules. Of the two programs, though, *Galactic Brain Benders* is more likely to appeal to older children.

Charming Mouse on a Quest

Imagine an adorable little rodent in search of a remedy for her ailing grandmother. Well, that's the plot in *Mia: The Search for Grandma's Remedy* (★★★★; \$30), from Kutoka Interactive (877/858-8652, www.kutoka.com). As Mia's faithful guide, your child must solve nine language-related puzzles to unlock the clues for a successful quest. The dazzling artwork and sound complement the learning tools as children ages five to nine try to decipher where Mia should go next.

Number Magic

Whether it's mastering basic arithmetic or learning fractions, elementary-level math is a must. And although memorizing multiplication tables will never be as fun as playing kickball with friends, these learning tools can make math more enjoyable.

Madeline 1st & 2nd Grade Math (★★★; \$30), from The Learning Company (800/716-8506,

www.learningco.com), proves that even a cultural icon can sometimes be annoying. This two-disc set—for ages six to nine—teaches

basic math skills by using interactive puzzles.

The activities are challenging and the graphics are attractive, but Madeline's exaggerated French accent can be hard on the ears.

For preteens, the imaginary world of Gretchen and Wilbur in *I Love Math* (★★★½; \$20), from DK Interactive Learning (888/342-5357, www.dk.com), will get your kids excited about learning math. In this learning game, kids use math skills to save the world from Gretchen

and Wilbur, who've traveled back through time to wreak havoc. In Atlantis, kids must conquer fractions to repair the island's broken water pipes; in the land of the Aztecs, they manipulate shapes to open a locked temple. With four difficulty levels and



Words in Space On *I Love Spelling's* planet Aquatica, kids earn points by clicking on moving bubbles to spell words.

three play modes, there's plenty to keep older children occupied for hours.

Math Arcade (★★★; \$10) is another fun math tool for older children. Arc Media's (416/410-4429, www.arcmedia.com) animated game lets kids choose math-related exercises in four areas: addition and subtraction, multiplication and division, telling time, and pattern recognition. Biff, a Beavis look-alike whose mouth never stops moving, acts as host. And a series of correct answers earns an interesting fact, such as a description of Neil Armstrong's first step on the moon.

Challenging Word Drills

With DK Interactive Learning's (888/342-5357, www.dk.com) *I Love Spelling* (★★★½; \$20), children practice spelling by playing interactive word games on four wacky planets (see "Words in Space"). Like the other games in the *I Love* series, *I Love Spelling* lets kids choose a level of difficulty; they can also select particular word groups—animal-related words, for example—to work on.

Interactive Science for Curious Kids

If you're tired of answering your child's endless questions—or you're ashamed to admit that you really *don't* know how rockets work—then *My First Amazing Science Explorer* (★★★★; \$30), from DK Interactive Learning (888/342-5357, www.dk.com), is just the ticket for young inquiring minds. Kids get to explore and learn scientific facts in eight environments, from city streets to the countryside. They can even perform simple experiments and record their observations in a printable workbook.





MIND EXPANDERS

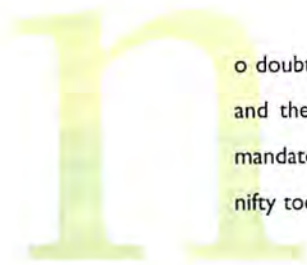

o doubt about it. The best parts of high school are the Friday-night football games and the senior prom. But along with these extracurricular activities come a few mandatory geometry quizzes and college-admission exams. Luckily, we've found some nifty tools to help young minds master these skills plus much more.

¿Dónde está el baño?

Students traveling abroad might need a refresher course in Spanish 101. And with *51 Languages of the World* (♦♦♦; \$30), from Transparent Language (800/752-1676, www.transparent.com), the learning doesn't stop with the Romance languages. Master the common European languages, along with Chinese, Japanese, and Korean. For eager students, there are even lessons for Tagalog, Turkish, and Thai. And even though Yiddish is included, the best jokes simply can't be translated.

The core goal of *51 Languages* is simple: immerse the student in the language through conversation. Users of *51 Languages* can also record their own voices in order to compare their pronunciation with that of prerecorded native speakers. Helpful panels display the meanings of, and grammatical information about, the words, but the lack of documentation makes learning the program more difficult than mastering a foreign language.

Explore English

Discover More English (♦♦; \$10), from Arc Media (416/410-4429, www.arcmedia.com), is designed to improve your child's understanding and appreciation of the English language. Journeys to historical sites both real and fictional—Stonehenge, Elizabethan London, Frankenstein's castle—accompany an itin-

erary sprinkled with facts about English literature and grammar.

As with Arc Media's other *Discover More* lessons, a magic elevator stops on floors hosting different historical scenes. When you click on a particular object, a small animation accompanies some literary or grammatical nugget. Entry to



Magical History Tour Dr. Frankenstein's laboratory is just one of the venues your child will visit on *Discover More English's* historical tour.

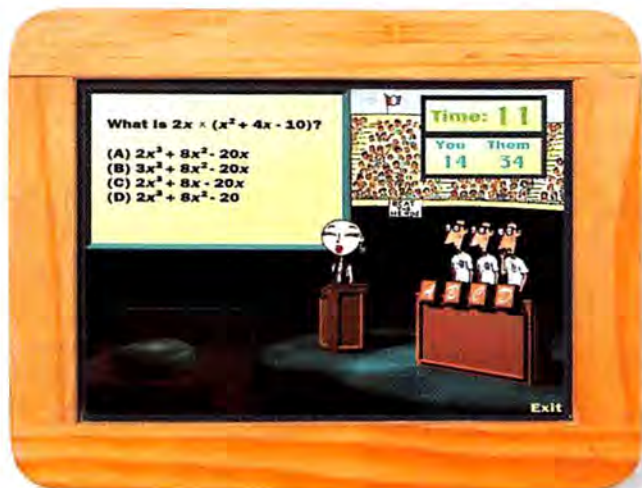

Quiz Show If your kids can beat the nerds in *Algebra Edge's* game show, they'll be on their way to acing algebra class.

the first floor is free; after that, participants must answer a one-question quiz on each level to ascend to the next level.

The graphics are decent, but the animations are crude and unlikely to appeal to the preteen crowd, at whom the product is aimed. Our advice: put the \$10 toward tickets to Shakespeare.

Count on It

Like to help out with your teenager's math homework but can't remember the difference between a discriminant and a derivative? Mathematics software may be the answer.

We looked at three math packages for high schoolers: *Princeton Review Math Library* (♦♦♦♦; \$40) and *Princeton Review Algebra Edge* (♦♦♦½; \$40), both from The Learning Company (800/716-8506, www.learningco.com), and *Math Advantage 2000—High School* (♦♦½; \$40), from Aces Research (510/683-8855, www.acesxpert.com).

Princeton Review Math Library, a six-CD set, covers a full range of high-school math, from Algebra I through calculus. Each CD contains an individual tutorial covering a separate

subject. The programs lack the whizbang graphics of other programs in the Princeton Review series, but that doesn't make them any less effective. Each lesson is well organized and provides both solid instruction on basic concepts and good feedback on progress, but the exercises would be more helpful if incorrect answers were explained step-by-step.

Math Advantage 2000 also covers the gamut from Algebra I to calculus. The seven-CD package is accompanied by a workbook that contains hundreds of practice problems. The tutorial section is a tad more stimulating than a math textbook, and the exams state whether the answer is right or wrong. If you make a mistake, though, there's no explanation of what went wrong or the correct way to solve the problem. For general high-school math tutorials, stick with Princeton Review Math Library.

As the name implies, Algebra Edge is focused on Algebra I, divided into two sections: Grade Builder Algebra I and Algebra Smart. Both lessons inject a bit of entertainment into the training sequences by incorporating animated videos, rock-oriented soundtracks, quiz-show games, and narration with an attitude. And since you can customize the lesson sequence, Grade Builder Algebra I can be organized to match your child's algebra textbook. Both Grade Builder Algebra I and Algebra Smart are likely to ease the pain of learning algebra, although the price tag on this package seems a bit steep for a single subject.

Sharpen Your No. 2 Pencil

Sure, the school year is just starting, but it's never too early (or too late) to start thinking about college- and grad-school-entrance exams. Three test-preparation packages for soon-to-be-graduates are certain to get them into exam mode: a crash course, Kaplan Emergency Prep for the SAT/ACT (♦♦♦½; \$20), from Knowledge Adventure (800/545-7677, www.knowledgeadventure.com), and two more-comprehensive packages, Princeton Review's Inside the SAT, ACT & PSAT 2000 Deluxe (♦♦♦½; \$40) and Inside the GRE, GMAT & LSAT (♦♦♦½; \$40), from The Learning Company (800/716-8506, www.learningco.com).

Recognizing that what a standardized test really measures is your ability to take standardized tests, all three offer test-taking strategies, along with vocabulary-building exercises and geometry drills. But Kaplan Emergency Prep for the SAT/ACT takes a friendlier, less intimidating approach than the others, offering a simpler interface and more hand-holding. You may find it a bit too folksy for your tastes, but if you've put off studying until the week before the test or need a last-minute refresher course, this is the package for you.

If you have the luxury of stretching your test-preparation homework over months rather than days, the Princeton Review products will reward you with multiple sample tests, compared to Kaplan's single test, and more-extensive information about college admissions and financial aid. For example, Inside the SAT, ACT & PSAT 2000 Deluxe lets you look up average SAT scores for hundreds of colleges and comes bundled with a companion book on how to get financial aid. Inside the GRE, GMAT & LSAT offers advice on choosing between the new computer-based version of the GRE and the traditional pencil-and-paper version and includes sample tests for both. **m**

The author of the "Early Learners" section, Contributing Editor CHRISTOPHER BREEN, was a preschool teacher for five years and is still a kid at heart. After testing the products in the "Homework Helpers" section, Contributing Editor FRANKLIN TESSLER and his faithful assistants, ALYSSA and ADAM TESSLER, are ready for another school year. Contributing Editor HENRY BORTMAN and eight-year-old accomplice SARAH SCHANZ-BORTMAN, authors of the "Mind Expanders" section, are anxiously awaiting an opportunity to show off their newfound math and verbal skills.



Publish 99 CONFERENCES

For additional
information, go to
www.publish.com
/conferences99.

To register,
call 888-887-3679 or
650-286-2799. Space is
limited! Take advantage
of the early-bird discount.
Register by September
24 and save \$100.

Publish Magazine Presents

The Second Annual Conference on Mixed-Platform Publishing

Mastering Digital Workflows

Asset Management, PDF and Networks in a Mixed-Platform Environment

Coronado Island Marriott Resort
San Diego, California
November 3-5, 1999

Publish

If you are interested in exhibiting,
write to exhibit@publish.com.

TOPICS INCLUDE:

Selecting, Building,
and Managing an Asset-
Management System

The ABC's of PDF

Building a PDF Workflow

Creating and Maintaining
Optimum Networks for
Cross-Media Publishing

Mixed-Platform
Management

Achieving Perfect Color
in a Mixed-Platform
Environment

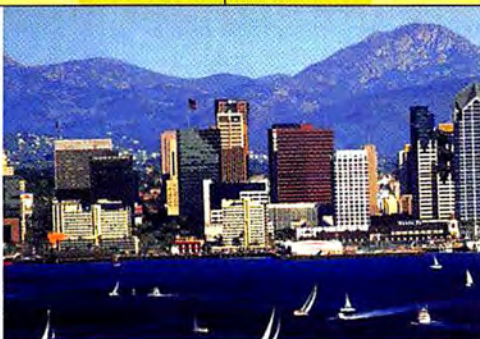

Intimate Interactive Informal



"This conference will certainly help our company make the
decisions that will help us to improve our product."

Carl Mirsky, Network Administrator, Allured Publishing,
1998 conference attendee



Secrets

Mac OS 8.6 Optimization Tricks

GET THE NEW SYSTEM SOFTWARE UP AND RUNNING WITH A MINIMUM OF FUSS AND BOTHER

by Ted Landau

Mac OS 8.6 won't flabbergast you with flashy new features. Instead, what you get is increased stability—fewer crashes—and a faster Mac. That's because Apple has made numerous “under the hood” changes—from improving how the Macintosh processor divides its time among multiple open applications to fixing a bushel of bugs.

Although most users will find updating to this system quick and painless, there are potholes lurking on the road to OS 8.6 success. If you're not alert to the dangers, it can seem as if 8.6 causes more problems than it fixes. Here's how to keep the road as smooth as possible.

Don't Stall at the Install

The first trick is to get the OS to install the way you want it to.

Missing Files Mac OS 8.6 includes updated versions of system software. However, if you use the Mac OS 8.6 Update (available free from Apple's Web site), you'll find that some of this software, such as ColorSync and Macintosh Runtime for Java, doesn't get installed. It's not a bug. Some of the software simply isn't included in the Update. To get the missing software, you have two choices: get the Mac OS 8.6 CD, which includes *all* the files (for \$19.95 from Apple if you own OS 8.5; 800/795-1000) or get the additional files as separate downloads from Apple's Web site, at



<http://asu.info.apple.com/swupdates.nsf/artnum/n11386>. You'll find links to most of these files on the Update page, but in a few cases, you'll have to dig deeper. Two important files that you have to get elsewhere are Apple's OpenGL 1.0 (<http://asu.info.apple.com/swupdates.nsf/artnum/n11420>) and IomegaWare (www.iomega.com/software/updates.html). As a bonus for going the download route, you get software that's even newer than the versions included on the Mac OS 8.6 CD.

Finally, Apple goofed and forgot to put the updated Internet Access exten-

sion (version 1.3) in the Mac OS 8.6 Update. It's available only on the 8.6 CD. But don't worry, version 1.2 is almost identical.

Files That Won't Install The Mac OS Update Installer can be fussy about what it decides to install. For starters, it won't install newer versions of certain files unless it finds an older version on your hard disk. In a few cases, it won't install the new version even if the old version *is* on your disk. For example, if you've moved Sherlock from its default location in the Apple Menu Items folder,

continues

Mac OS 8.6 Installer won't install the new version. Similarly, if you've renamed any Mac OS extensions or control panels (perhaps to modify their loading order), these may not get updated. One solution is to restore the original names and locations before updating. Otherwise, you can use Apple's TomeViewer utility to extract the desired files from the Mac OS 8.6 Tome (you'll find it buried in the Update Install Pieces folder) and install the files yourself.

Gone for Good In a few cases, the Mac OS 8.6 Installer deliberately removes files from your disk without replacing them with an update. For instance, it gives the familiar Jigsaw Puzzle the heave-ho. It also disposes of the Desktop Printing Extension—an unnecessary extension that can cause freezes.

Keep It Running Smoothly

Once you've installed the OS successfully, watch out for these obstacles.

Memory Shortage Some applications require about 300K more memory than they needed in Mac OS 8.5. It's a good idea to give a boost to any application that's acting up—select Get Info for the app, select Memory from the Show pop-up menu, and increase the Preferred Size. Sherlock is one program that will benefit from a memory increase of at least 300K if you've added many Sherlock Internet search-site plug-ins.

Font Bug If you're experiencing system crashes, you could have a font problem. Certain older fonts can get corrupted under Mac OS 8.6. Even if you don't have such fonts in your System Folder, you may have one embedded in an application, such as the font your Mac uses to create bullets when you type a protected password. Currently, there are two solutions (and you can use both): Install DiamondSoft's Font Fixer for 8.6 extension ([ww2.fontreserve.com/update/fontfix.html](http://www2.fontreserve.com/update/fontfix.html)) or run the Corrupt FOND Fixer application, from Alsoft (www.alsoft.com).

Shutdown Failure You may get an erroneous message when you attempt to shut down with OS 8.6 running on your Mac. The message says that you can't shut down because some applications have not quit. If this message appears even after you've quit all applications, any of various extensions may be the culprit. Try updating SwitchRes 1.5.X to version 2.0 or disabling LibMotosh, if you have either of those extensions.

Crash Course Most remaining problems will likely require an updated version of some software. For example, printing from Adobe PageMaker 6.5.X can cause a crash when you're using Mac OS 8.6 (Adobe is working on a fix). The companion software to G3 processor upgrades (especially upgrades for the L2 cache slot of Power Mac 6400s and

6500s) has been known to cause start-up crashes under Mac OS 8.6. Check for an updated version.

Road repairs are over. It's time to relax and take your new OS for a spin. **m**

Contributing Editor TED LANDAU serves up the latest Mac OS 8.6 troubleshooting tips at his MacFixIt Web site (www.macfixit.com).

Give the Finder a Boost

DO YOU HAVE A WISH LIST OF FEATURES you'd like to add to the Finder? Your wishes may already have been granted. A collection of freeware and shareware patches enhances the power of the Finder.

Although none of these patches are exactly alike, they have significant overlap. For example, they all add ⌘-key shortcuts (such as ⌘-T for Empty Trash) to the Finder's menus. It's best to select the one that best suits your needs and use only that patch. Also, follow the directions that come with these patches *very carefully*—otherwise, the Finder may crash at start-up. (You can find links to all the patches mentioned here at www.macworld.com/1999/10/secrets/ or www.macfixit.com.)

Chakaranda's Mac OS 8.6 Finder Patch, Jon's OS 8.6 Mods, and Finder 8.6 Patch all primarily add assorted ⌘-key shortcuts to the Finder's menu. Jon's OS 8.6 Mods and Finder 8.6 Patch go a step further, adding a Finder-Quit command. You can use this command to quit the Finder similarly to the way you quit any other application. The benefits are that it frees up extra memory and possibly regains memory lost to a "leak." If you quit all other open applications, the Finder will relaunch. As a bonus, you can hold down ⌘-option and rebuild the desktop without needing to restart the Mac.

Jerry's Finder 8 Patch combines almost all the features of the previous three patches and then heads off into new territory. It increases the memory allocation to the Finder (which may help reduce Finder crashes and let you keep more windows open). It also modifies the

Finder's naming schemes. For example, if you're tired of deleting the *alias* suffix from the name of every alias file you create, you can use this patch to keep the suffix from appearing.

8Tuner is more than a patch—it's an application that gives you complete control over which of its many options to install (see "Customize the Finder"). Among the options you can choose from are the Finder Menu Tuner, which lets you select your own ⌘-key shortcuts for Finder menu items, and Identity Tuner, which lets you change the text About This Computer in the Apple menu to anything you want, such as About Ted's G3 Speed Demon. And, like Jerry's Finder 8 Patch, 8Tuner enables you to change the default names of aliases, file copies, and untitled folders.



Customize the Finder If there's something about the Finder that you don't like, such as the way it names copied files (the option shown here) or its default ⌘-key shortcuts, 8Tuner will be happy to change it.

Tips, Tricks, and Shortcuts

by Lon Poole

Do you need to reposition your icons every time you mess around with the resolution of your monitor? Instead of buying a shareware utility to reset your desktop-icon positions after switching resolutions (as suggested in June 1999's *Secrets*), you can quickly create an AppleScript application to do the job. Edouard Doubrovski, of Hanover, New Hampshire, was the first reader to contribute the following procedure. First, open the AppleScript Script Editor program. Then switch to the Finder, select all your permanent desktop icons (don't select a CD icon or any other icon that comes and goes from the desktop), and drag them as a group to a slightly offset position. Next switch to the Script Editor application and click the Record button. Switch back to the Finder by choosing it from the Application menu, which will ensure that the selected desktop icons remain selected, and drag the icons back to their former positions. Go back to the Script Editor once more, click the Stop button, and save the script as an application. Now you can reset your desktop icons by opening the application you just created.

Ensure Cable-Modem Security

Q I recently got a cable modem. Although I have a dynamically changing IP address, I'm concerned about hackers. How can I stay secure?

TODD VAZIRI
Los Angeles, California

A Security is indeed a real issue, as a cable-modem connection effectively makes your computer part of a local network consisting of all your neighbors who also have cable modems. If you have file sharing turned on, your computer will show up as an AppleShare server in the

Chooser of any neighbor who has a Mac and a cable modem. Your IP address is irrelevant, because file sharing uses the AppleTalk protocol, not TCP/IP. Likewise, an AppleTalk printer (such as a LaserWriter) that's connected to the same Ethernet hub as your cable modem will also appear in neighbors' Choosers. Neighbors with PCs and cable modems won't see your Mac or your printer unless they've installed software to enable Windows to use the AppleTalk protocol, such

file sharing turned on, double-click the Guest icon in the Users & Groups control panel and make sure guest connections are disabled. Make sure to do this on all Macs that are connected to your Ethernet network. With guest connections disabled, users will need to know a valid user name and password to connect to one of your networked Macs that has file sharing turned on. Set up user names and passwords in each Mac's Users & Groups control panel.

Another option is to isolate AppleTalk services such as file sharing from your neighbors' cable modems. You can do this by installing a second Ethernet port on one Mac, together with Internet gateway software such as the \$54 SurfDoubler and \$155 SoftRouter Plus, from Vicomsoft (www.vicomsoft.com), or the \$89 IPNetRouter, from Sustainable SoftWorks (www.sustworks.com). Then connect your cable modem to the second Ethernet port and connect the built-in Ethernet port to your hub. You can also use a hardware gateway that has dual Ethernet ports, such as the \$495 SonicWall, from Sonic Systems (www.sonicssys.com).

The gateway hardware or software forwards Internet traffic but not AppleTalk traffic between the two Ethernet ports and enables all network computers to share the Internet connection.

Snap and Scroll in Photoshop

TIP If you're working in Adobe Photoshop (versions 3.X to 5.0) and have palettes scattered all over your screen, you can snap them against the

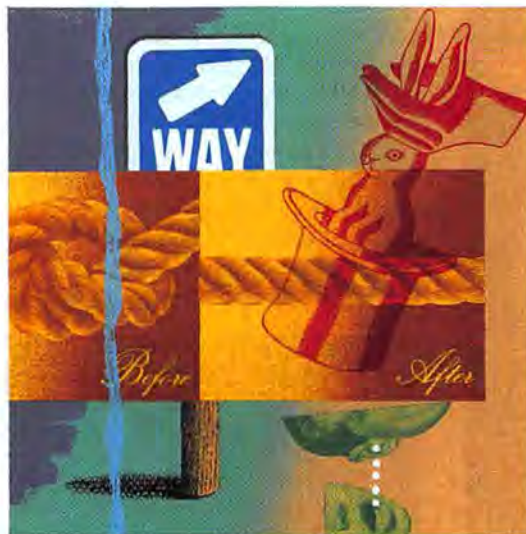

as the \$199 PC MacLAN software, from Miramar Systems (www.miramarsys.com).

So how to protect yourself? Well, your first option is to turn off file sharing in the File Sharing control panel (the Sharing Setup control panel in Mac OS 7.6.1 and earlier)—then your Mac won't show up in anyone's Chooser. You can also turn off your AppleTalk printer when it's not in use, and it likewise won't be accessible to others.

However, if your Mac is connected to an Ethernet network with other Macs in your home or office and you need to have

continues

Get everything
you're looking for:

Macworld **Get**
Info

www.macworld.com/getinfo

Macworld's
Reader Service

"Get Info" with options! Now you can get information on all the products and services you see in *Macworld*. And get it faster. Simpler. Better. Easier. All you need to do is visit one Web site:

www.macworld.com/getinfo

Then select the products, the categories or advertisers for whom you want to receive information. That's it. You can have the information delivered to you by e-mail, snail mail or even telephone. Or you can click on a link that will take you to the vendor's Web site in one easy step.

PLUS! Coming in November the return of the hard card! A traditional perforated card that allows you to circle your info choices as you read *Macworld* on the train, on the plane or where-ever you are. Then drop the card in the mail and it's on the way!

Macworld

nearest edge of the screen by shift-clicking their title bars.

Also, while zoomed in on an image, try scrolling with the oft ignored page up, page down, home, and end keys. Press the shift key while pressing page up or page down to scroll exactly 10 pixels instead of a screenful. In Photoshop 5.0, you can also scroll left and right by pressing the ⌘ key in conjunction with any of these page-up or page-down shortcuts.

JEFF GRANDON
Bath, New York

Revisit Your Local Host

The trick for visiting your Personal Web Sharing Site by typing `localhost` in Microsoft Internet Explorer's address field (mentioned in July 1999's *Quick Tips*) prompted several readers to describe other methods that should work with all browsers and Internet-client applications. Brian Ashe, of Orlando, Florida, was the first to suggest typing `127.0.0.1` into your browser's location box. This IP address is the TCP/IP standard for accessing a server on the same machine as the client. If your computer is running additional TCP/IP servers or a server with more features than Personal Web Server, you can preface that IP address with a prefix such as `ftp://`, `http://`, or `telnet://` to reach the desired service. Orya Blu-

menfeld Girton, of Cambridge, England, points out that the address `0.0.0.0` should also work.

Michael Shafae, of Belmont, California, doesn't like typing IP addresses, so he creates a hosts file in SimpleText to define names that refer to the appropriate IP addresses. Then he sets the TCP/IP control panel to Advanced mode, by choosing User Mode from the Edit menu; clicks the Hosts button that appears in the upper-right corner of the control panel; and selects his hosts file from the dialog box that appears.

Here's an example of a hosts file:

```
localhost CNAME pm7100.mydomain.net
pm7100 CNAME pm7100.mydomain.net
g3pb CNAME g3.mydomain.net
pm7100.mydomain.net A 127.0.0.1
g3pb.mydomain.net A 192.168.6.5
```

This file has two kinds of definitions. Each line containing *CNAME* links the nickname (at the beginning of the line) to the full name (at the end of the line). Each line containing an *A* specifies the IP address for a full name. The three parts of each line are separated by tabs or spaces. This example file specifies that the three names—`localhost`, `pm7100`, and `pm7100.mydomain.net`—all refer to the computer whose IP address is `127.0.0.1`, which is the computer with this hosts file. This file additionally specifies that the two names `g3pb` and `g3pb.mydomain.net` refer to the computer whose IP address is `192.168.6.5`.

Make AppleWorks Database Buttons

APPLEWORKS 5.0 (AND CLARISWORKS) DOESN'T HAVE A TOOL FOR MAKING buttons on a database layout, but you can make them with the following method devised by Jeffrey L. McLean, of Woodbridge, Virginia. In layout mode, either paste or draw a button graphic (A). If necessary, create a label for the button, using the text tool (B); move the label over the button graphic; and group them. Then define a check-box field (C) and move it over the button graphic. Resize the check-box field to fit just inside the edges of the graphic. Move the check-box field to the back so the button graphic covers it. You can hide the check-box field completely by making its pen pattern and fill pattern transparent and turning off its Show Label option, using the Field Info command.

To create action that happens when someone clicks the button, first record an AppleWorks macro that per-

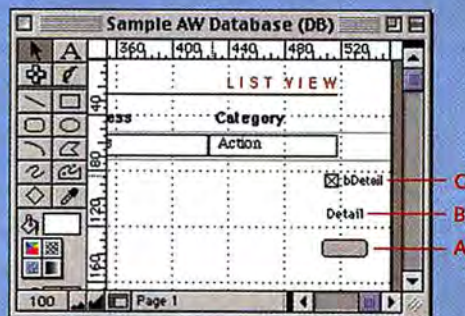

Speak and Be Heard

Take heart, you iMac and G3 users who have tried in vain to surf the Internet by voice command as described in July 1999's *Quick Tips*. You need version 1.5.4 of PlainTalk, Apple's speech-recognition software, which comes with Mac OS 8.6 (<http://asu.info.apple.com/swupdates.nsf/artnum/n11386>) and is also available separately (<http://asu.info.apple.com/swupdates.nsf/artnum/n11400>). PlainTalk 1.5.4 can use 44kHz sound input, the standard rate on iMacs and blue-and-white G3s; works with the iMac's built-in mic; and has other pluses that benefit many Mac models. **m**

LON POOLE answers readers' questions and selects reader-submitted tips for this monthly column. He authored *Macworld Mac OS 8.5 Bible* (IDG Books Worldwide, 1999) and coauthored *The Little Network Book* (Peachpit Press, 1999).

All shareware and freeware mentioned in *Quick Tips* is available from the Macworld Online software library (www.macdownload.com).

We pay \$25 to \$100 for tips selected for publication that discuss how to use Macs, peripherals, or software. Please include your full name and address so that we can send you your payment. Send questions or tips to quicktips@macworld.com or to Macworld Quick Tips, 301 Howard St., 16th Fl., San Francisco, CA 94105. All published submissions become the sole property of *Macworld*. Due to the high volume of mail received, we cannot provide personal responses.

forms the desired action. Then define a calculation field with a formula like this: `IF('bDetail',MACRO("Detail View"),MACRO("Detail View"))`

Here, bDetail is the name of the check-box field and Detail View is the name of a macro that changes the layout.

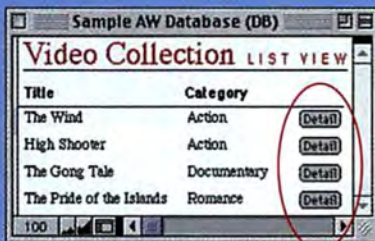

Conquer Disk Damage



Introducing DiskWarrior™, a revolutionary new way to restore damaged disks!

DiskWarrior is a revolutionary new utility that combats disk damage. It quickly rebuilds, recovers and optimizes your HFS and HFS Plus disk directories, eliminating all directory errors and recovering lost files. Other utilities attempt to repair disks by patching the damage. Patching can result in more damage and permanent loss of files.

100% Recovery Assurance

Only DiskWarrior builds a new optimized directory using data recovered from the damaged directory. You have 100% assurance that DiskWarrior will always restore your disks and recover your files when directory damage is your enemy.* You'll also have 100% confidence that you're getting the desired results. DiskWarrior's exclusive Preview ability lets you preview the restoration. You can examine your damaged disk in the Finder as it will appear after the directory is restored but before any changes are made to your disk.

Routine Maintenance

DiskWarrior is your first line of defense against unseen disk damage. Running DiskWarrior regularly prevents small unseen problems from becoming large ones by keeping your directories error free. You'll also keep your directories optimized to speed up overall disk performance.

©1998 Alsoft, Inc. PO Box 927, Spring, Texas 77383-0927 USA. 281-353-4090 or fax 281-353-9868. DiskWarrior is a trademark of Alsoft, Inc. *Visit our web site or call for requirements. DiskWarrior is not a magician. No utility can restore directories that have been written over.



THE UTILITY COMPANY

ALSOFT

www.alsoft.com 800-257-6381

Choose 140 at www.macworld.com/getinfo

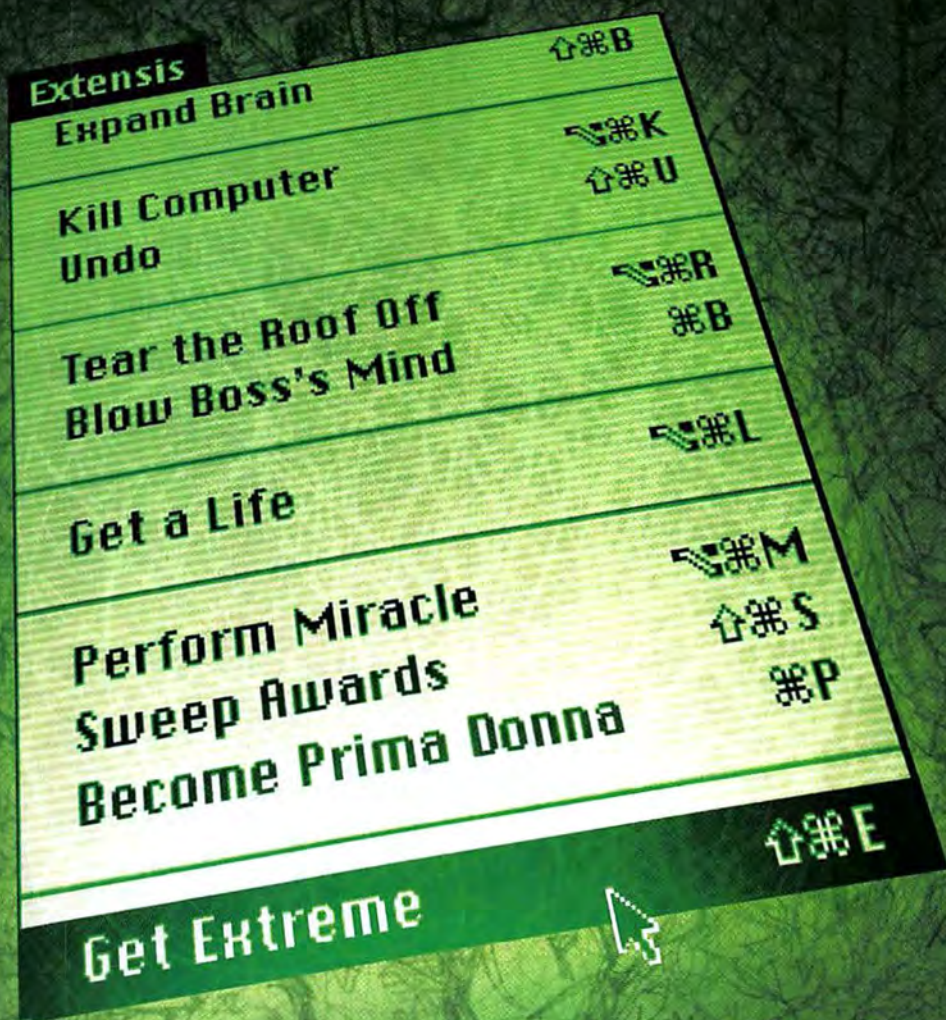

Get extreme with the Extensis® Extreme Upgrade for Adobe® Photoshop®. You get the Adobe Photoshop 5.5 upgrade and four of the best selling Extensis Plug-ins for Photoshop for only \$429.00*. You'll save about \$500.00!

That's extreme!

Save about
\$500!



Extensis Extreme Upgrade for Adobe Photoshop \$429.95*

DOWNLOAD FREE TRIAL VERSIONS

800.796.9798

www.extensis.com/extreme

Extensis

Copyright 1999 Extensis Corporation. All rights reserved. Extensis, PhotoFrame, PhotoTools and the Extensis logo are trademarks of Extensis Corporation. IntelliHance Pro is a trademark of DPA Software and contains trade secrets of DPA. Adobe and Photoshop are trademarks of Adobe Systems Incorporated. Macintosh is a registered trademark and Mac and QuickTime are trademarks of Apple Computer, Inc. Microsoft, Windows and Windows NT are registered trademarks of Microsoft Corporation. PowerPC is a registered trademark of International Business Machines. Pentium is a trademark of Intel. All other trademarks are the property of their respective owners. * Estimated street price for Photoshop 5.0 to 5.5 after rebate from Adobe Systems Inc.

EXMWA010899

Choose 14 at www.macworld.com/getinfo

Master Streaming with QuickTime 4

HOW TO PRODUCE BOTH LIVE AND ON-DEMAND STREAMING MOVIES

by Jim Heid

When it comes to streaming audio and video over the Internet, there are two approaches you can use: you can deliver files with the same old HTTP server that delivers your Web pages and graphics, or you can use a streaming technology that provides real-time streaming for more-reliable and more-flexible results.

The HTTP method is easy and inexpensive, since you don't need any special server software (see "Watch This: Streaming Video on Your Web Site," *Create*, April 1998). But HTTP streaming has significant drawbacks. Besides being less reliable, it doesn't permit *seeking*—if users try to fast-forward to a particular spot, playback stops until everything up to that point downloads. Also, HTTP can't do live Webcasting, so it's unsuitable for special events such as live concerts or speeches and for radio or TV stations that want to expand to the Internet.

Until recently, QuickTime was an HTTP-only medium. But with version 4, QuickTime joins RealNetworks' RealSystem G2 and Microsoft's Windows Media Technologies (formerly Netshow) in providing support for true, real-time streaming.

QuickTime 4 streaming has a lot going for it. You can use most of the same tools and techniques you've been using to create HTTP-streaming QuickTime movies. And talk about flexibility: streaming QuickTime movies play back in any program that supports conventional, nonstreaming QuickTime flicks. Therefore, you can embed streaming QuickTime movies in a Macromedia Director project, a Microsoft PowerPoint presentation, or even a Microsoft Word document.

Although QuickTime isn't the best product for all users (it can be much



harder to use than RealSystem G2, and it lacks features that broadcasters and other professionals require; see the QuickTime 4 Pro review, elsewhere in this issue), it still has some advantages. It's inexpensive, making it well suited to educational institutions and budget-minded businesses. And because QuickTime streaming is part of the QuickTime architecture, you can do some slick things that you can't do with the competing products.

With this in mind, let's take a look at the QuickTime-streaming production process. Along the way, I'll pass along some production tips for both on-demand and live-event streaming.

I'm OS X, and I'll Be Your Server

You can create QuickTime 4 streaming movies on just about any Mac, but to

serve the movies, you need a Power Mac G3 running Apple's \$495 Mac OS X Server software. Mac OS X Server includes a program, QuickTime Streaming Server, that dishes out streaming QuickTime movies.

This Mac OS X Server foundation is both an asset and a liability. On the plus side, Mac OS X Server is built on a rock-solid Unix foundation, which makes it more resistant to crashes and gives it greater multitasking abilities than the Mac OS currently provides—both critical components for true streaming.

But Mac OS X Server isn't nearly as easy to use as Mac OS 8.X. You don't have to know anything about Unix to be able to serve QuickTime streaming content and manage your server, but you may

continues

Create On-Demand Streaming Movies

PREPARING MOVIES FOR on-demand (as opposed to *live*) streaming is a multistep process. First, you compress the movie to accommodate your target bandwidth. This step is identical to preparing a movie for HTTP streaming or even CD-ROM playback. In this phase, you also *hint* the movie, a process that adds streaming data used by QuickTime Streaming Server. You store the hinted movie in the default directory of QuickTime Streaming Server.

Finally, you create a *pointer file*, which sets up the dialogue between QuickTime Streaming Server and a user's QuickTime Player or browser plug-in. You stash this pointer file on your HTTP server and link to or embed the file in your Web page.

Here's how to perform each step, using Apple's QuickTime Player (if you'll do a lot of streaming, do yourself a favor and get Terran Interactive's Media Cleaner Pro 4, which streamlines many of these chores).

Sizing and Compressing

For movies containing a video track, one of your first steps involves deciding on a final movie size and frame rate. For streaming to 28.8-Kbps modems, a typical size is

a tiny 128 by 96 pixels or a slightly better 160 by 120, with a lowly frame rate of 2 or 3 frames per second (fps). That won't exactly yield a dramatic movie experience, but hey, these are modems we're talking to. If your movie contains very little motion, you might try a 192-by-144 frame size and 4 to 6 fps. If you

are talking to 56-Kbps modems, you might try a 176-by-144 or 192-by-144 frame size, with 4 to 6 fps. And for ISDN and better connections, you can bump the frame rate up to about 10 fps.

When specifying compression settings for both video and audio tracks, you must choose data rates carefully, so as

You might find it helpful to add *.h* to the file name of your exported movie to indicate that the movie is hinted and ready for streaming. Be sure to end the movie's name with *.mov*, though.

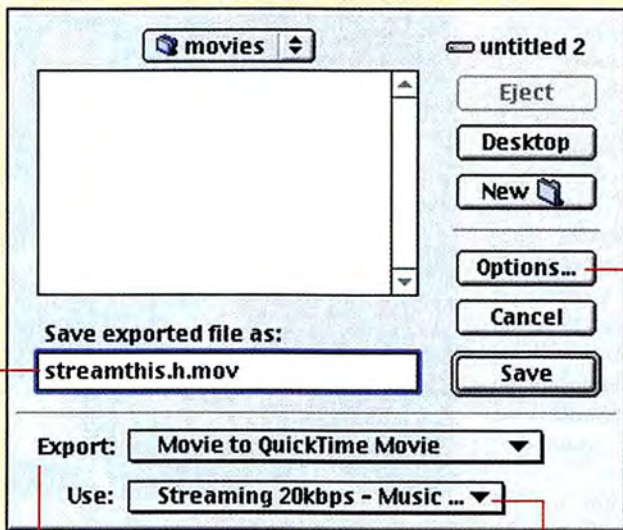

Be sure to choose *Movie To QuickTime Movie*.

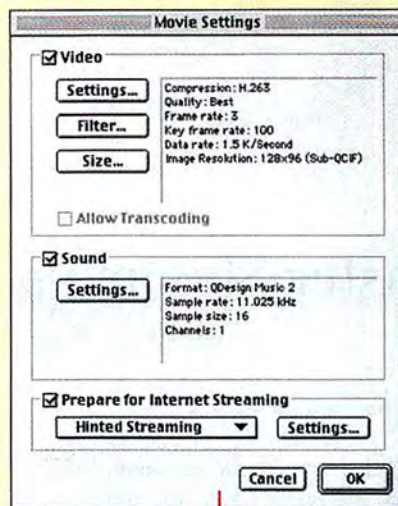

To examine and tweak the compression settings for the preset you've chosen, click on *Options*.

Choose the desired preset from the *Use* pop-up menu.

Default Settings
Most Recent Settings
Streaming 20kbps - Music - High Motion
Streaming 20kbps - Music - Low Motion
Streaming 20kbps - Voice - High Motion
✓ Streaming 20kbps - Voice - Low Motion
Streaming 40kbps - Music - High Motion
Streaming 40kbps - Music - Low Motion
Streaming 40kbps - Voice - High Motion
Streaming 40kbps - Voice - Low Motion
Streaming 100kbps - Music - High Motion
Streaming 100kbps - Music - Low Motion
Streaming 100kbps - Voice - High Motion
Streaming 100kbps - Voice - Low Motion

not to exceed your target bandwidth. For example, to deliver a streaming movie to users with 28.8-Kbps modems, you will want to keep a movie's data rate to about 22 Kbps—this provides you some breathing room to allow for noisy connections. Consider a data rate of 12 Kbps to 14 Kbps for the video track and about 8 Kbps for the audio track.

You can use the Options button in the Export dialog box to specify data rates and frame rates by hand, but there's an even easier way. Apple has endowed QuickTime Player with a variety of presets for the most-common streaming scenarios. (These presets also add the hinting required for streaming.) The video settings use either the Sorenson Video or H.263 compressors, whereas the audio settings use the QDesign Music compressor for music or the Qualcomm PureVoice compressor for spoken audio.

Not everyone agrees with all of the settings choices that Apple made—for example, compression guru Jim Baker prefers the Sorenson Video compressor to the H.263 compressor Apple chose for several of the modem-oriented presets. Every compression scenario is unique, however, and Apple's presets

are a good starting point for your own compression adventures.

To export a movie for QuickTime streaming, just open the movie in QuickTime Player and then choose Export from the File menu.

Create the Pointer File

Now you're ready to create the pointer file. This requires that you access the hinted movie through QuickTime Streaming Server, so be sure the server software is running. If you're running Mac OS 8.5 under Mac OS X Server, you can perform this step on the same computer that's running the server software. Or you can use any computer running QuickTime 4—including a Windows machine—as long as that computer has Internet or network access to the machine running QuickTime Streaming Server.

1. Choose Open URL from QuickTime Player's File menu.

2. Type the URL of your hinted movie (such as `rtsp://yourserver/mymovie.h.mov`) and press return. QuickTime Player will connect to QuickTime Streaming Server and begin streaming the movie. Let the movie play for a few seconds if you like, and

then click on QuickTime Player's stop button.

3. Choose Save As from the File menu. In the Save As dialog box, click on the Make Movie Self Contained button, name the movie, and click on Save. In doing so, you'll make a small (about 1K) movie that points to the hinted movie.

4. Copy this pointer file to your HTTP server (not to the machine running QuickTime Streaming Server), and then link to or embed the pointer file in your Web page.

Create Multiple-Data-Rate Movies

As mentioned in the main text, you can use a QuickTime reference movie to access separate versions of a movie for various connection speeds. After compressing and hinting each movie, copy them to the Mac running QuickTime Streaming Server. Next, create a pointer file for each movie, storing each pointer file in the same folder.

Finally, using Apple's free MakeRefMovie utility, assign each of the pointer files to its appropriate connection speed. Save the reference movie in the same folder as the pointer files, copy the whole shebang to your HTTP server, and link to or embed the reference movie in your Web page.

have to wade into Mac OS X Server to get streaming working in the beginning.

Of Streams and Bits

It's common practice to provide several versions of a movie or audio clip, each compressed for a particular connection speed. Since version 3, QuickTime has supported *multiple-data-rate* movies, which enable you to accommodate various connection speeds without having to litter a Web page with multiple links (see "Optimize Web Video for QuickTime 3," *Create*, August 1998).

To recap briefly, when creating a multiple-data-rate movie, you have to make a separately compressed version for each connection speed and then create one *reference* movie that points to each version. Then you must link to or embed the reference movie in your Web page. To create reference movies, use either Apple's free MakeRefMovie utility (available from the Authoring area of the QuickTime Web site, at www.apple.com/quicktime/) or Terran Interactive's wonderful Media Cleaner Pro (www.terran.com).

These concepts apply to QuickTime streaming movies, too. But there's one additional step: after compressing the final movie, you must create a small *pointer file* that sets up the conversation between QuickTime Streaming Server and a user's computer (see "Create On-Demand Streaming Movies"). If you've worked with RealNetworks' technology, you're familiar with this concept—in the Real world, this file is called a *metafile*.

Let's Go Live

Being able to Webcast live streams is one of the best things about true, real-time streaming. QuickTime 4 delivers nicely, thanks to Sorenson Vision's \$199 Broadcaster (www.s-vision.com). Broadcaster performs real-time encoding, compressing audio and video on the fly and then sending that single stream to a *second* Mac running Mac OS X Server and QuickTime Streaming Server (see "Broadcasting with Broadcaster").

That's right: you need two computers to do a live Webcast with QuickTime 4. One computer, running Broadcaster under Mac OS 8.X, does the real-time compression, while the other, running QuickTime Streaming Server, serves the streams. You'll almost certainly want to

Broadcasting with Broadcaster

SETTING UP A LIVE QUICKTIME STREAMING BROADCAST INVOLVES RUNNING Sorenson Vision's Broadcaster on a Mac with OS 8.X (the *encoding machine*) and configuring that Mac to send a stream to a second Mac running QuickTime Streaming Server and Mac OS X Server. And configuring that second Mac to send a stream to a third Mac running QuickTime 4 and Mac OS X Server. It's then a matter of configuring the QuickTime 4 Mac to send a stream to a fourth Mac running QuickTime 4 and Mac OS X Server. And so on.



Mac OS 8.X running Broadcaster

Connect your video and audio equipment to the encoding Mac. (To encode video, you'll need a Mac equipped with video-digitizing hardware.)

QuickTime Streaming Server

In the configuration shown here, QuickTime Streaming Server is being used as a *replication server*. It's taking the single stream supplied by the encoding machine and replicating it as multiple streams: one for each user who's listening to or watching your stream.

Internet users running QuickTime 4

To allow users to connect to your stream, you must create a pointer file for the stream and then link to or embed it in a Web page.

run Broadcaster on a G3-equipped Mac—in my tests, I successfully used a gray-haired Power Mac 7600 to live-encode a low-fidelity (voice-only) stream, but the computer was too slow to encode a stream of music.

What if you want to deliver multiple live streams for various connection speeds? You'll need multiple G3 Macs, each running a copy of Broadcaster that encodes for a different speed. Unlike RealNetworks' RealProducer G2 family of encoders, Broadcaster can't encode multiple streams simultaneously.

This multiple-Mac scenario sounds expensive, and indeed, it can be. But depending on your situation, it can still be less expensive than buying RealSystem G2 server software. For instance, the 100-stream RealSystem G2 server software costs \$5,995. You can buy a few G3 Macs for that price—and be able to serve up to ten times the number of streams. For heavy-traffic live streaming, then, QuickTime's multiple-Mac requirement

isn't a significant drawback. (For lighter-traffic scenarios, though, the scale tips in RealSystem G2's direction.)

Tuning Out

When you look closely at QuickTime 4 streaming, it's clear that Apple is behind the competition in key areas. But that doesn't mean that QuickTime is out of the running—far from it. It has some unique assets that other streaming technologies lack. I've already mentioned one: the ability to embed streaming QuickTime movies in any program that supports conventional QuickTime movies.

Another QuickTime advantage has to do with interactivity within movies. With tools such as Totally Hip Software's LiveStage (www.totallyhip.com) or Electrifier's Electrifier Pro (www.electrifier.com), you can create clickable buttons and hot spots *within* movies. With QuickTime 4, these so-called *wired* movies can also stream. RealSystem G2's support for the Synchronized Multimedia Integration

Language (SMIL) also allows for powerful streaming interactivity, but SMIL is an HTML-like tagging language with a fairly steep learning curve. With QuickTime, if you're creating wired movies for other media, such as CD-ROMs, you can use the same tools and skills to create wired movies for streaming.

So although QuickTime streaming may not outstream the competition in every area, it still has a lot going for it and is the right choice for some applications. It's definitely a technology worth watching—and listening to.

Special thanks to Jim Baker of Compression Factory (www.compressionfactory.com) for his insights and recommendations. For samples of video and sound he has compressed, visit the Apple QuickTime Showcase page, at www.apple.com/quicktime/showcase/. **m**

A contributor to *Macworld* since 1984, JIM HEID (www.heidsite.com) writes, lectures, and consults on Web multimedia technologies.

Web Graphics Made Easy

BEAUTIFY YOUR WEB SITE THE SIMPLE WAY WITH ADOBE IMAGESTYLER

by Tom Negrino

Everyone wants her or his Web site to look sharp, but the reality is that many of us building sites are not trained designers. Maybe you're in sales or marketing and the boss just gave you the responsibility of building the company Web site—with no budget for an artist. Or maybe you're just eager to express yourself on the Web and don't want to deal with the expense and steep learning curve associated with big graphics guns like Adobe Photoshop. If you need good results quickly and inexpensively, Adobe's \$129 ImageStyler is just the answer for nondesigners trying to create a beautiful Web site.

The Beauty of Objects

Adobe released ImageStyler around the same time it released another Web-graphics program, ImageReady, and confused folks because the names are so similar. But the two programs are actually quite different, and one main reason is ImageStyler's object-based nature.

ImageStyler lets you work with objects and vectors, which are scalable and nondestructive (whereas ImageReady and Photoshop let you work mainly with static bitmapped images; see the feature "Photoshop Discovers the Web," elsewhere in this issue, for more on Photoshop 5.5 and ImageReady). This means you can do things with ImageStyler that are impossible with Photoshop and ImageReady. For example, if you edit or transform an image by adding filters, rotating, or cropping and then change your mind, your original image will still be intact. You can edit without consequences, since you can revisit and change artwork anytime after the original session. ImageStyler encourages experimentation and doesn't punish you for trying new things.



Everything in ImageStyler is an object, whether it's a photo, a block of text, or a shape. You can apply styles to any object (a style is a combination of color, gradients, opacities, textures, and other effects), and an object can have up to five layers, each containing any combination of effects. Another bonus is that you don't have to laboriously create each graphic separately and then piece them together in a Web-page-layout program. You can create graphics and lay them out in the ImageStyler window and then just export the file; ImageStyler generates the individual graphics and the HTML file that defines the layout for the Web.

On the following pages, I outline two ways that ImageStyler excels for the nondesigner creating a Web site. You will learn how to construct attractive buttons that have different Java-

Script rollover behaviors (see "Make Snazzy Rollover Buttons") and how to create nice-looking text (see "Create Instant Graphical Text"). (To learn an additional technique—how to composite custom-shaped images—go to www.macworld.com/1999/10/create/.)

Even though ImageStyler is designed for the casual artist, professionals will also find it a handy addition to their arsenal. It allows you to quickly apply effects to images and text, and you can save ImageStyler compositions in Photoshop format for further tweaking. If you create graphics for the Web, ImageStyler should be part of your tool kit. **m**

Contributing Editor TOM NEGRINO is a coauthor of *JavaScript for the World Wide Web, Visual QuickStart Guide*, third edition (Peachpit Press, 1999).

continues

MAKE SNAZZY ROLLOVER BUTTONS



CREATING NAVIGATION BUTTONS—even making simple effects like drop shadows—in Photo-

shop can take quite a bit of time and expertise, and there's no easy way to quickly try out a

series of effects. This is where ImageStyler really shines. You can create custom button shapes using the tool palette or pick one of the dozens of shapes included in the Shapes palette. If none of those shapes fit your needs, you can import any EPS graphic (such as an Adobe Illustrator or Macromedia FreeHand file) and store it in the Shapes palette. Then you can dress up the shape using ImageStyler's Textures and Styles palettes.

ImageStyler also takes all the pain out of adding Java-

Script rollovers to your buttons. Not only does it write all the JavaScript code for you, but it also treats the rollover action as just another attribute of the button object. That means you can move, copy, or edit the object as you wish without having to readjust the rollover effect. When you're ready to publish your Web page, ImageStyler exports an HTML file that includes all of the JavaScript required to make the effects work. Here's how I made the buttons for my sample site, "Sharks!"

1. I wanted to make buttons with sharks on them, so I dragged an EPS file of a shark from the Finder into ImageStyler's drawing window. I scaled the image using the selection handles. I chose the diamond shape from the Shapes palette and then clicked on the Matte button at the bottom of the palette.

To create three buttons, I selected the one I had made and chose Edit: Make Alias two times. Since they're aliases, changes made to any button will be reflected in all three.

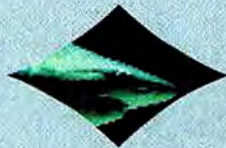

2. I dragged the three buttons into a rough vertical stack, and evened out the spacing by selecting all three and choosing Object: Align: Horizontal Centers, followed by Object: Distribute: Vertical.

To add a style to the three buttons, I selected one of them, found a style I liked in the Styles palette, and clicked on the Apply button. All of the buttons updated simultaneously.

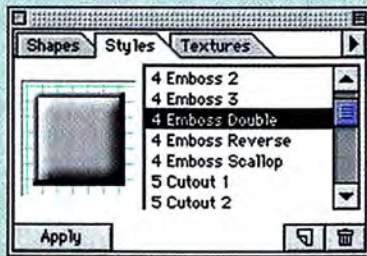

3. Next I selected the text tool and clicked in the document window. In the Type Tool window, I typed the button text *home* and set the font, style, and size. I wanted the text to be highlighted when a Web surfer's cursor rolled over the button, so I turned to the JavaScript palette.

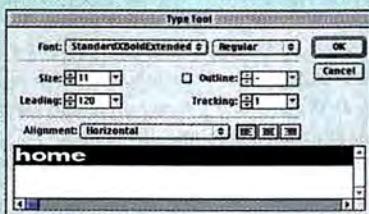

4. In the JavaScript palette, the basic state of an object is noAction. To create a new state, I clicked on the New button at the bottom of the palette, which activated the onMouseOver state (see "What Does That Code Mean?").

Using any of ImageStyler's tools, you can change the appearance for the onMouseOver state to a different color, style, gradient, texture, shape, size, or position. To add a URL to a state, enter the URL in the Web palette. To add onMouseDown or onMouseOut states, repeat the above.



5. After I got the first text object looking just the way I wanted it to, I chose Edit: Duplicate and changed the duplicates' text to *sharks* and *history*. Then I dragged each text object over its respective button. Under Window: Export, I selected a graphics format (you'll usually want GIF or JPEG) and chose AutoLayout.

When I chose File: Export, ImageStyler rendered the button images and created an HTML file, including all of the JavaScript needed to make the button rollovers work.

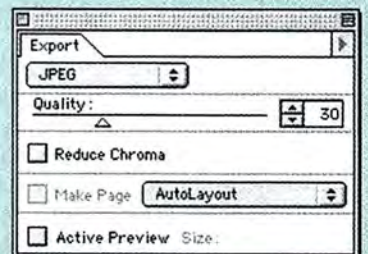

CREATE INSTANT GRAPHICAL TEXT



ONE OF THE COOLEST FEATURES of ImageStyler is its ability to read an HTML file, apply an ImageStyler template, and turn text

that's tagged with an HTML headline style into antialiased graphical text. This is a great way to dress up your site. You can use

the technique to make sharp-looking buttons and navigation bars, as well as spiced-up headline text. Here's how to do it.

1. First, make the graphical template in ImageStyler. To do this, create a text object and style it as you wish. It doesn't matter what the text says, because it will be replaced by text from the HTML file. To tell ImageStyler that the text is meant to be replaced, select a replacement heading such as H2 from the Web palette. If the replacement

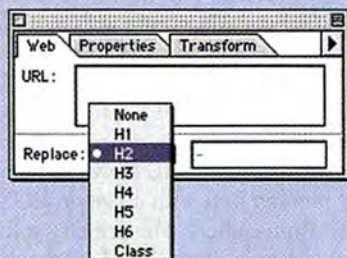

text is on top of a shape (as it would be for most buttons), ImageStyler will render the text object and the shape together when the replacement takes place.

2. Next, create the HTML content. Open an HTML editor such as BBEdit, type in the headlines, and tag them with Heading 2. The text should look like this:

```
<H2> Shark Facts</H2>  
<H2> Spotlight on Species</H2>  
<H2> FAQ's</H2>
```

Then save the document with a name like replace.html.

3. Now go back to ImageStyler, choose Window: Export, and pick the graphics format that you want.

TIP: If you choose GIF, hold down the shift key while dragging the Colors slider, and the number of colors snaps from 256 to 128 to 64 and so on.

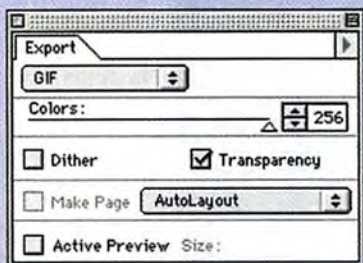

4. Now choose File: Batch Replace HTML and select the replace.html file. ImageStyler will then render as many images as you have tagged and rewrite the replace.html file to reference the new graphics files. It will also automatically create a copy of the original replace.html file and rename the original replace.old.



If you open the replace.html file in a browser, you'll see the new graphics, as shown here.

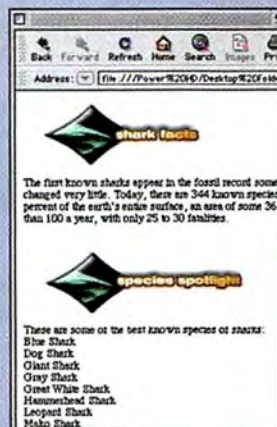

What Does That Code Mean?

IF YOU'RE NOT FAMILIAR with JavaScript events, the terminology can be a bit confusing. Here's what the different events mean.

onMouseOver The chosen effects happen (for example, the button changes from blue to yellow) when a Web surfer rolls the cursor *over* the object.

onMouseOut The chosen effects happen when a Web surfer's cursor rolls *off* the object.

onMouseDown The chosen effects happen when a Web surfer *clicks* on the object.

Make Your Pictures Move

SHAKE UP STILL PHOTOS WITH MOTION EFFECTS

by Mike Wooldridge

One of the many freedoms that digital-image manipulation offers is the capability to depict motion without need of a video camera. You can give the feeling of movement and the impression of passing time in a single image by using digital effects, a combination of still images, and your imagination.

Chicago-based photographer Jeff Schewe used digital techniques to add a temporal twist to an image of a long jumper in flight. By compositing seven photos—which were shot with a motor-driven, film-based camera—and applying subtle Adobe Photoshop effects to blur the trailing edges of the jumper's body, he conveys the feel of a short

movie clip in a single image.

The long-jump piece, designed for a Motorola marketing brochure, is typical of Schewe's photo-realistic style. He prefers to scan his photos at very high resolutions and then work with the high-res files in Photoshop. For this image, he took dozens of photos in his studio of a man jumping, picked the best ones to create a cohesive series of motion, and applied masking techniques and blur effects in Photoshop.

Schewe also tries to retain the fine detail associated with film in his digital creations. Here, he added an extra layer atop the images to recover some of the grainy texture present in the original film but lost during the Photoshop manipula-

tion. As a result, the final image doesn't appear digitized, even at close range.

Because the Photoshop files, with all their layers, can be as large as a gigabyte, Schewe's computer has to pack a lot of power. For this project, he used a Day-Star Genesis Mac clone with a 400MHz Newer G3 upgrade and 1GB of RAM. Schewe also uses an Imacon FlexTight Precision II scanner, plus a Seagate Sidewinder AIT tape drive for archiving his supersize projects. He shot the original photographs with a Canon EOS-1N RS 35mm camera. His primary software tool is Adobe Photoshop 5.0. **m**

MIKE WOOLDRIDGE (mike@thatguy.com) is a freelance writer and new-media artist.



JEFF SCHEWE

Get Moving Schewe's final image is the result of compositing the best seven images out of dozens of photographs and applying blur effects to enhance the look and feeling of motion. The interplay between sharp and blurred edges—which gives the piece its real impact and movement—would have been difficult to achieve by camera alone.



1 The long-jumper image combines both outdoor and indoor photographs. Schewe first shot photos of the runway and sandpit outside at a track-and-field stadium on a misty day.

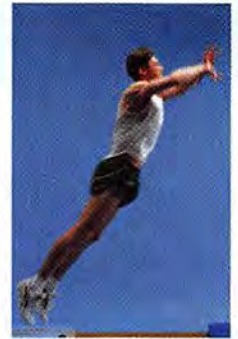

2 He then photographed the long jumper in front of a blue screen in his studio, using a motor-driven camera that captured the action at 6 frames per second. Schewe took many photos of the model jumping and then mixed and matched shots from the different takes to get seven sequential images that fit together aesthetically. He scanned the seven chosen photographs at 3,200 dpi, brought each one into its own layer in a Photoshop file, and masked the jumper from the blue background so he could swap in the misty background.

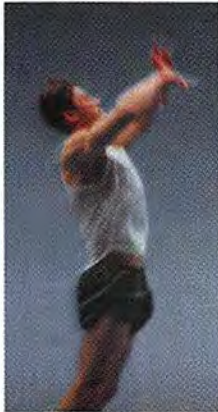
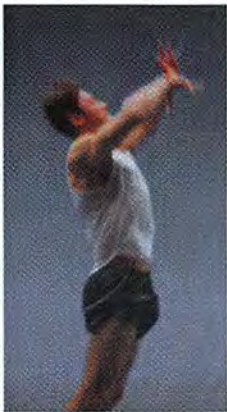

3 To accentuate the appearance of motion in the images, Schewe added blur at the edge of the jumper's body. He did this by duplicating each frame, lowering each duplicate's opacity, and then staggering the duplicates underneath and to the left of the original frames. This added a faint blur trailing each image of the jumper while leaving the sharp details of the jumper's body intact.

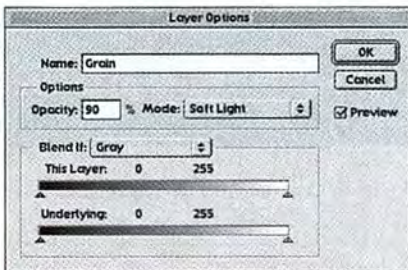

4 The Photoshop manipulation caused some of the original photos' graininess to drop out. To recover it, Schewe created a grainy gray layer, set the layer to Soft Light and Blend If: Gray in the Layer Options dialog box, and added the layer on top of the composite image.

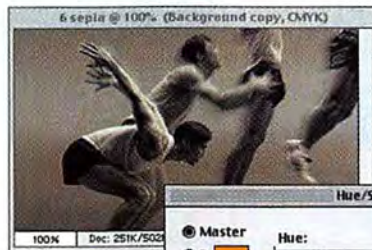

5 Schewe finished by converting the color image to sepia, by applying a Hue/Saturation adjustment layer with Hue set to 38 and Saturation set to 12.

Don't miss out!

Attend the most focused industry event for DV professionals.

DV[®] THE DIGITAL VIDEO CONFERENCE & EXPOSITION

NEW!

Web Video Boot Camp: October 18, 1999

Conference: October 18-22, 1999

Exposition: October 20-21, 1999

**Long Beach Convention Center
Long Beach, CA**

**Web Video • Production • Editing
Motion Graphics • 3D Visual Effects
Corporate Video • Compression
DVD • Cameras • Business**

Join the leaders in digital video technology for five days of in-depth training.

You don't have time to learn all there is to know—so here's your chance to learn all you *need* to know.

Register Early and Save!

Supporting Technical Sponsors:



FAST
The Art of Digital Video.



PINNACLE
SYSTEMS

Media Sponsor:

DV

Media Co-Sponsors:

3D
VIDEOGRAPHY
Game
DEVELOPER

WEBTechniques
Macworld

Please send me a free copy of the Digital Video Conference & Exposition Catalog

Name

Title

Company Address

City

State

Zip

Phone

Fax

Email

Fax to: 888-811-7391 • outside the U.S. fax to 972-906-6890

Or visit our web site and request a catalog!

www.dvexpo.com

Macworld[®] DISCOUNT CARD

Save up to **74%** on *Macworld*, the magazine Macintosh users rely on for product reviews, in-depth articles, technical advice, and more. Act now and receive the exclusive *Macworld* **Clip Art CD-ROM** containing an extensive collection of images, digital stock photos, fonts, and more — **FREE!**

Return this card today to receive your special, low discount rate **PLUS** your **FREE Clip Art CD-ROM!**

\$95.88	ANNUAL COVER PRICE
\$34.97	YOUR DISCOUNT RATE
FREE CLIP ART CD	YOUR BONUS

Name _____ (please print) 5SR28

Company _____

Address _____

City _____ State _____ Zip _____

E-mail Check box if you would like to receive periodic e-mail offers from carefully screened providers of quality goods and services.

Payment enclosed. Bill me later.

Choose One:

1 year (12 issues) \$34.97
SAVE 64%

2 years (24 issues) \$49.97
SAVE 74%

Annual newsstand price \$95.88. Non-U.S. add US\$20 per year; Canadian GST included. Your FREE CD-ROM will be shipped upon payment. This offer does not include monthly CD-ROMs.

Check us out on the Web —
<http://www.macworld.com>



NO POSTAGE
NECESSARY
IF MAILED
IN THE
UNITED STATES

BUSINESS REPLY MAIL

FIRST-CLASS MAIL PERMIT NO. 66 BOULDER, CO

POSTAGE WILL BE PAID BY ADDRESSEE

Macworld[®]

Subscription Department
PO Box 54506
Boulder, CO 80323-4506



INDEX TO ADVERTISERS

Interact with the companies whose products and services are advertised in **Macworld**

ADVERTISER	INTERACT	PAGE NO.	ADVERTISER	INTERACT	PAGE NO.
Adaptec	www.adaptec.com/mac	37	Kensington	www.kensington.com/imac BC	
AEC Software	800/450-1982	8			
Agfa Corporation	www.agfahome.com	41	La Cie	—	IFC, 1
Agio Designs	800/688-2446	10			
AIWA	www.aiwa.com/csd	11	Mac Zones	www.maczone.com	107-115
ALSOFT	800/257-6381	93	Macromedia	800/457-1774	7
American Power Conversion	888/289-APCC ext. 8731	49	MacSoft	www.gtstore.com	43,58
Anthro	www.anthro.com	6	MacWarehouse	800/355-5841	116-123
APS Technologies	800/285-0638	132-137	Macworld Expo	www.macworldexpo.com	73
			Meade Instruments	800-62meade	54
Bottom Line Distribution	800/990-5692	140	MetaCreations Corp	800/846-0111	45
			MicroMat	800/829-6227	26
CDW Computer Centers, Inc.	800/509-4239	138,139			
CNET	—	24,25	Newer Technology	www.newertech.com	IBC
Connectix	www.connectix.com	46	Nikon Electronic Imaging	www.nikonusa.com	18
Dataviz	800/270-0030 ext. 133	51	Orange Micro	714/779-2772	20,50
Diehl Graphsoft	www.diehlgraphsoft.com	22			
			Pangea Software	www.toucanstudio.com	16
Extensis	www.extensis.com	94	Publish Conferences	www.publish.com	88
Formac	www.formac.com	14,15	TDK	www.tdk.com	31
			Tektronix	www.colorathome.com	12,13
GCC Technologies	www.gcctech.com	4,5	The Digital Video	www.dvexpo.com	104
Global Village	www.globalvillage.com	19			
			ViewSonic	800/888-8583	55
Hire Knowledge	www.hireknowledge.com	53	VST Technologies, Inc.	www.vsttech.com	10,52
Infowave	www.infowave.com	47	Wacom Technology Corp.	800/922-2585	39
Interland, Inc	800/599-0547	48	Webby Awards	www.webbyawards.com	79
J&R Computer World	800/221-8180	142	XLR8 by Interex	www.xlr8.com	21

PRODUCT INDEX

Looking for a specific product? Simply use *Macworld's* product index to find the page or the advertiser of the products which interest you. Then simply log on at www.macworld.com/getinfo and receive all the product information you need.

PAGE NO.	ADVERTISER	GET-INFO	PAGE NO.	ADVERTISER	GET-INFO
----------	------------	----------	----------	------------	----------

ACCESSORIES

FURNITURE

6	Anthro	—
10	Agio Designs	265

HARDWARE

BOARDS

IBC	Newer Technology	55
21	XLR8 by Interex	59
37	Adaptec	—
14,15	Formac	—
20,50	Orange Micro	60

DIGITIZERS/SCANNERS

18	Nikon Electronic Imaging	56
41	Agfa Corporation	158

DISPLAY

55	ViewSonic	—
----	-----------	---

ENTERTAINMENT

20,50	Orange Micro	60
-------	--------------	----

EXPANSIONS/UPGRADES

21	XLR8 by Interex	59
----	-----------------	----

HARD DISKS/STORAGE

IFC,1	La Cie	—
11	AIWA	299
140	Bottom Line Distribution	221
132-137	APS Technologies	62

INPUT DEVICES

BC	Kensington	1
----	------------	---

MISCELLANEOUS

11	AIWA	299
39	Wacom Technology Corp.	84
49	American Power Conversion	72

MODEMS

19	Global Village	106
----	----------------	-----

POWERBOOK

10,52	VST Technologies, Inc.	73
-------	------------------------	----

PRINTERS

4,5	GCC Technologies	43
12,13	Tektronix	95

SECURITY

49	American Power Conversion	72
----	---------------------------	----

MAIL ORDER

140	Bottom Line Distribution	221
142	J&R Computer World	282
107-115	Mac Zones	71
116-123	MacWarehouse	150
132-137	APS Technologies	62
138,139	CDW Computer Centers, Inc.	2

SERVICES

MISCELLANEOUS

53	Hire Knowledge	207
----	----------------	-----

ON LINE

24,25	CNET	—
-------	------	---

SOFTWARE

BUSINESS

8	AEC Software	203
---	--------------	-----

CAD/CAM

22	Diehl Graphsoft	46
----	-----------------	----

COMMUNICATION

51	Dataviz	142
----	---------	-----

ENTERTAINMENT

16	Pangea Software	—
43,58	MacSoft	29

GRAPHICS/DTP

7	Macromedia	36
45	MetaCreations Corp	5
94	Extensis	14

MULTIMEDIA

7	Macromedia	36
---	------------	----

MUSIC

31	TDK	—
----	-----	---

ONLINE

48	Interland, Inc	10
----	----------------	----

SCIENTIFIC

54	Meade Instruments	79
----	-------------------	----

UTILITIES

26	MicroMat	67
46	Connectix	105
47	Infowave	32
93	ALSOFT	140

macZone®



the next generation of



NEW FROM Apple!

**Reserve
Yours
TODAY!**

Apple iBook... the iMac to go!

With all the features we love about the iMac packed into an eye-catching, crunch-resistant case, the iBook can roam where you want to – in the home, to class, even on nature hikes. You may need a recharge before the battery does!

- 12.1" active-matrix TFT SVGA display
- 300MHz PowerPC™ G3 processor
- 512K backside L2 cache
- 32MB SDRAM, expandable to 160MB
- 3.2GB IDE hard drive
- Up to six hours running time on a single charge of its Lithium-Ion battery
- 56K modem
- 10/100BASE-T Ethernet
- 24x CD-ROM drive (max. var. speed)
- AirPort wireless Internet connection option (antennas already built-in)
- USB Port
- Mac® OS 8.6 operating system
- Crunch-resistant polycarbonate case
- Weighs only 6.7 pounds

**ONLY
\$1594⁹⁸
EACH**

Tangerine #110915

#110917 AC Power Adapter for iBook	\$79.99
#110918 Rechargeable Battery for iBook	\$139.99

Blueberry #110916

Set yourself free from network cables & phone cords

iBook AirPort Base Station

- Communicates w/AirPort 42 Card at 11 Mbps
- Built-in 10/100Base-T Fast Ethernet port
- Built-in K56Flex V.90 modem • 150-foot range

AirPort gives you a simple, affordable way to bring the Internet to every room in your home or every desk in your classroom – at up to 11 megabits per second. Just install the AirPort 42 Card and connect to an AirPort wireless network. Then start surfing from your couch, a shady lawn outside your dorm, or anywhere else up to 150 feet from an AirPort Base Station. AirPort also lets multiple computers share a single Internet connection simultaneously without expensive additional ISP accounts, telephone lines, or messy cabling.

#110919 AirPort 42 Card\$99.98

**ONLY
\$294⁹⁸
#110920**



**GO
WIRELESS!**

JUST ANNOUNCED AT MACWORLD!

Corporate bids welcome!
Fax to 1-800-684-8080

Source Code
MW910

Order by Phone
1.800.436.0606

Order Online Today
Zones.com™

A NASDAQ COMPANY Ticker Symbol: MZON



the next generation of



Brand New from Apple!

Apple iBook...the iMac to go!

- Crunch-resistant polycarbonate case
- Battery life of up to six hours
- Weighs only 6.7 pounds

#110917 AC Power Adapter for iBook . . . \$79.98
#110918 Rechargeable Battery for iBook \$139.98

RESERVE NOW FOR ONLY \$1594⁹⁸ EACH



Tangerine
Item #110915

Go Wireless!

ALSO AVAILABLE NOW!



ONLY \$294⁹⁸
#110920

iBook AirPort Base Station

- Surf the net or network with other iBooks wirelessly*
- 150' range lets you and the iBook roam around the home or classroom

*Requires the AirPort card
#110919 AirPort 42 Card \$99.98

Blueberry
Item #110916



Mac Zone Exclusive!

FREE

Microsoft Internet Explorer 4.5 and Microsoft Outlook Express 4.5 with any Apple® CPU purchase!

Ask for Item #107700

*While supplies last! Shipped in generic packaging.

FREE STUFF

at www.zones.com/freestuff

Like this!

FREE MYST

Ask for #103750
*plus \$2.98 shipping and handling. All offers while supplies last. Subject to change without notice.



iMacs NOW 333MHz!

All flavors feature:

- 333MHz PowerPC™ G3 processor
- 512K backside cache
- 32MB SDRAM memory
- Two 12Mbps USB ports
- 6.0GB hard drive
- 24X variable speed CD-ROM
- 56K modem
- 10/100Base-TX Ethernet
- 15" monitor (13.8" viewable)
- 6MB SGRAM video memory
- ATI Rage Pro 2D/3D graphics card
- Mac OS 8.5



ONLY \$1194⁹⁸ EACH



Choose your favorite flavor

- Strawberry #102986
- Lime #102989
- Tangerine #102988
- Grape #102987
- Blueberry #102985

FREE Software Included



with every Apple® iMac! \$400 Value!
Titles are subject to change. Retail packaging not included.

\$1 a day brings an iMac your way!
Apple Loan Program
CALL NOW TO APPLY!

4-Year Extended Service Agreement \$189⁹⁸
Ask for #106494

MacSense iCatch \$9⁹⁸ ONLY
#102671



Give your iMac mouse the shape and feel of a standard mouse!



AppleCare iMac

Two year extension
Extends warranty coverage two additional years (3 years total)
Includes keyboard and mouse

Pick your favorite iMac color!



HP DeskJet 882C Color Printer
only **\$299⁹⁸** **\$50 Rebate!**
#102363

HP DeskJet 895Cse Color Printer
only **\$399⁹⁸**
#60236

we're open 24/7
hours a day, 7 days a week



Credit cards are not charged until the order is shipped. Most products ship the same day (barring system failure, etc.). Shipping options include Ground, 2nd Day and Overnight delivery. Freight is based on average product weight. Handling extra. Insurance available. Special orders may require special shipping and handling charges. Call for international shipping rates. Prices and product availability subject to change without notice. Specials and promotions may be limited to stock on hand. Not responsible for typographical errors. All products sold by Multiple Zones International (MZI) are third party products and are subject to the warranties & representations of the applicable manufacturers, including but not limited to Y2K compliance. Accordingly, MZI makes no representation or warranty with respect to Y2K compliance of product sold. ©1999 Copyright Multiple Zones International Inc. All rights reserved. Unauthorized duplication is a violation of applicable laws. Apple®, the Apple logo, Macintosh® and PowerBook® are registered trademarks of the Apple Computer, Inc.

Any Purchase!

when you open an account with  E*TRADE

Get complete details at www.zones.com/etrade



FREE STUFF!
at www.zones.com/freestuff

For a complete selection of USB products visit www.zones.com/usb

USB IMAGING

NEW!  **ONLY \$219.98** #108018

Make Web videos with Avid Cinema

Capture Video with USB!
Avid Cinema for iMac

ONLY \$125.98 #97188

600x1200 resolution, 36-bit color, and great scanning software!
AGFA SnapScan 1212U Blue

\$99.98 - \$100 FREE #655652

When you open an E*TRADE account

UMAX Astra 2000U Scanner

**After \$30 mfr. mail-in rebate. Must be purchased with CPU. Expires 7/31/99. Low Zone Price \$129.98

USB STORAGE

ONLY \$299.98 #107091

Easy to use external USB Hard Drive!
LaCie External Drive USB HD

\$129.98 - \$100 - \$29.98* #95251

When you open an E*TRADE account

100MB of removable storage - fast and easy!
Omega USB Zip Drive

NEW!  **COMES IN 5 iMAC COLORS**

Outstanding print quality at 1440x720 dpi!
Epson Stylus 740i Color Inkjet Printer

ONLY \$229.98** #107815

\$229.98 - \$100 = **\$129.98*** #107815

When you open an E*TRADE account

**After \$50 mfr. mail-in rebate. Low Zone Price \$279.98. Expires 9/30/99

BIG SOUND

ONLY \$79.98 #101373

High-quality SRS surround-sound!
CoZo iMac Speakers

COMES IN 5 iMAC COLORS

\$99.98 - \$100 FREE #106357

When you open an E*TRADE account

Cool looking drive handles 1.44MB floppies!
Newer Udrive USB Floppy Drive

\$169.98 - \$100 - \$69.98* #109035

When you open an E*TRADE account

Use floppy disks and add 120MB storage!
Imation USB SuperDisk Drive 2X

NEW!

USB NETWORKING

ONLY \$199.98 #105499

Connect your iMac peripherals to a convenient swiveling base!
CompuCable iDock

ONLY \$78.98 #37060

Connect your existing printer to your iMac!
KeySpan USB Serial Adapter

ONLY \$299.98 #109060

FREE 8MB memory included!
Fuji DX-10 Digital Camera

ONLY \$59.98 #30039

The easiest way to hook up devices to your iMac!
Entrega 4-Port USB Hub for Mac

ONLY \$24.98 #31901

The mouse your iMac deserves!
MacALLY iMouse USB Mouse

ONLY \$39.98 #31906

Excellent response - plus the iMac look!
MacALLY iBall USB Trackball

ONLY \$48.98 #602571

The trackball iMac users have been waiting for!
Kensington Orbit Trackball - iMac Blueberry Blue

ONLY \$39.98 #101329

Put iMac power in the palm of your hand!
Ariston Ares USB Joystick

ONLY \$39.98 #31933

Full-size, soft-touch for comfort and control!
MacALLY iKey USB Extended Keyboard

ONLY \$49.98 #100676

Surge suppressor, mouse pad, CD-rack, and wrist rest!
Belkin iMac Starter Kit

Mac Zone Best Sellers!

Microsoft Office 98 Upgrade
FREE Extreme 6-pack #105036 **\$254.97**

Connectix Virtual PC 2.1 with Win 98
The key to running PC software on your Mac!
#20634 **\$168.98**

FREE Upgrade to Virtual PC 3.0*
*Shipping and handling applies.

Symantec Norton Antivirus 2000
The #1 virus protection for the Macintosh!
#00116 **\$23.98†**

*Price after \$40.00 mfr. mail-in rebate for upgraders. Low Zone price \$63.98. Offer valid for the life of the product.

Symantec Norton Utilities 2000
The smartest way to keep your computer working.
#04890 **\$44.98††**

*Price after \$50.00 mfr. mail-in rebate for upgraders. Low Zone price \$94.98. Offer valid for the life of the product.

NEW! **Quake II**
ONLY \$47.98 #51946

74181	StarCraft	\$48.98
51928	Simpsons Virtual Springfield	\$21.95
41484	Tomb Raider II	\$48.98
34779	Myth II	\$48.98
78710	Encyclopedia Britannica 99	\$48.98
106302	Groller MultiMedia Encyclopedia iMac Deluxe	\$47.98

Guaranteed Low Prices!

Visit us online at Zones.com to see our full selection of products at the latest price



Corporate bids welcome!
Fax to 1-800-684-8080

A NASDAQ COMPANY Ticker Symbol: MZON

Source Code
MW910

Order by Phone
1.800.436.0606

Order Online Today
Zones.com

Must haves for ANY PowerBook!

Newer Technology
FireWire 2 Go
PC Card



NEW!
ONLY \$249.98
#109764

Fuji MX-2700



FREE
16MB=24MB total
ONLY \$649.98
#109062

Nikon CoolPix 950



NEW!
2.11 Megapixels!
ONLY \$949.99
#608570

AsantéTalk



10-BaseT to LocalTalk Hub
FREE
#16630
*when you open an E*TRADE account.

PowerBook Software Best Sellers

ACT! Contact Manager 2.8



ONLY \$149.98
#06231

PowerPrint 4.5



FREE
#00642
*when you open an E*TRADE account.

Apple Remote Access



ONLY \$115.98
#96676

Sound Jam MP3 Player



ONLY \$49.98
#637018

Norton AntiVirus 2000



ONLY \$23.98*
#00116
*After \$40 mail-in rebate. Low Zone Price: \$63.98

FileMaker Pro 4.1



ONLY \$176.98
#52485

Office 98 Upgrade



ONLY \$249.97
#55870

Virtual PC 2.1



ONLY \$168.98
#20634
FREE Upgrade to 3.0!

Apple® PowerBook® Accessories



Newer BookEndz Docking Station for PowerBooks
As low as \$148.97
#60403



ixMicro Road Rocket For dual monitor support for your classic PowerBook G3
ONLY \$249.98
#03765



Apple DVD Drive Video Kit Includes: DVD Expansion Module, DVD PC Card, DVD Player Software
ONLY \$499.95
#102937



VST Mobility Bundle • Charger • Lilon Battery • AC Adapter
ONLY \$319.98
#34325



VST Internal ZIP Drive for Classic PowerBooks
ONLY \$229.95
#07159



VST SuperDisk Drive for Classic PowerBooks
ONLY \$219.98
#101365

Accessories for your NEW PowerBook® G3



VST 4GB Expansion Bay Hard Drive
ONLY \$306.98
#109513



VST Zip Drive for PowerBook G3
\$229.95 - \$100 = \$129.95*
#109510
*when you open an E*TRADE account.



VST SuperDisk Drive for PowerBook G3
ONLY \$229.95
#109512



Portable Printer Kit HP 340 with PowerPrint USB
Mobile Printing!
ONLY \$359.98
#108073



Apple Lithium-Ion Battery
2 for 10! Use 2 batteries for up to 10 hours!
ONLY \$126.98
#622731



Newer USB External Floppy Drive
FREE
#106357
*when you open an E*TRADE account.

What you'll find at Zones.com: Hot New Products • Online Auctions

Digital Cameras	
73283	Kodak DC260 Digital Camera \$899.98
608570	Nikon CoolPix 950 Digital Camera \$949.98
608571	Nikon CoolPix 700 Digital Camera \$569.99
93351	Sony Mavica FD91 with FREE 10pk Floppy Disks \$999.99
602326	Agfa CL30 Digital Camera \$389.98
602327	Agfa CL50 Digital Camera \$776.98
73282	Kodak DC220 Digital 2x Zoom Camera \$699.98
96363	Olympus D400 Zoom \$599.99
96364	Olympus D620L \$999.98
97195	Olympus D340R \$399.98
107813	Sony Mavica FD73 \$499.98
610054	Kodak DC265 \$899.98
617978	Sony Mavica FD83 \$699.98
77933	Epson 750 Z \$699.98
618993	Olympus C-2000 \$999.98
03578	Toshiba PDR-M1 \$399.98
617979	Sony Mavica FD88 \$899.98
625992	Fuji MX-6002 \$549.98
615993	Fuji MX-2700 \$849.98
615991	Fuji MX-10 \$299.98

Fixed HD / CD Drives	
102785	VST FireWire 4.0GB HD \$399.98
102786	VST FireWire 6.0GB HD \$499.98
70393	Viking II 4.5GB U/W SCSI Internal HD OEM \$237.97
70442	LaCie 4.5GB Internal SCSI HD \$239.98
70443	LaCie 9.1GB Internal SCSI HD \$359.98
70444	LaCie 4.5GB External SCSI HD \$329.98
101725	LaCie 9.1GB External SCSI HD \$469.98
107013	LaCie DVD-RAM External SCSI Drive \$749.98
95354	LaCie 2.6GB Single-Sided DVD-RAM Media \$29.98
95358	LaCie 5.2GB Double-Sided DVD-RAM Media \$39.98
109035	Imation iMac USB SuperDisk Ext Drive \$169.98
91952	Fuji CD-R 74min Single \$1.98
47562	Fuji CD-R 5 pack with \$10 Rebate \$14.98
59776	Fuji CD-R 10 pack with \$20 Rebate \$29.98
21258	Fuji CD-R 25 pack with jewel cases \$38.98

Zip Drives and Media	
51752	Zip Internal ATAPI w/5.25 mounting \$99.95
55181	Zip External SCSI Reconditioned \$89.95
12220	Zip External SCSI \$99.95
101712	Zip 250 External SCSI \$169.98
101727	Zip 250 Media \$19.95
101715	Zip 250 Media (6 Pak) \$99.95
52581	ZipPlus External SCSI/Parallel \$169.95
32251	Zip Large Carrying Case \$29.95
83475	Zip PowerBook SCSI adapter \$19.95
12236	Iomega Zip 100MB Mac Media Gray 3pk \$49.95
12237	Iomega Zip 100MB Mac Media Gray 6pk \$79.95
12238	Iomega Zip 100MB Mac Media Gray 10pk \$99.95
73831	Iomega Zip 100MB Mac Media Color 10pk \$99.95
88195	Fuji Zip Color 5pk with \$10 Rebate \$59.98
37185	Fuji Zip Color 10pk with \$10 Rebate \$79.98
88194	Fuji Zip Gray 5pk with \$10 Rebate & Free Case \$59.98
37186	Fuji Zip Gray 10pk with \$10 Rebate \$79.98
54009	Fuji Zip 20pk with 4 Free Disks by mail \$185.98
86334	Fuji Zip Media 100MB Mac Disk \$14.98

Removable HD and Media	
73771	Jaz 1GB SCSI Internal Drive Reconditioned \$189.95
73839	Jaz 1GB SCSI External Drive Reconditioned \$199.95
95233	Jaz 2GB SCSI Internal Drive \$349.95
95234	Jaz 2GB SCSI External Drive \$349.95
82841	Jaz Large Carrying Case \$29.98
43360	Jaz Card PCMCIA Fax SCSI 2 \$124.95
81235	Jaz 1GB Cartridge \$99.95
78663	Jaz 1GB Cartridge 3-Pack \$269.85
73835	Jaz 2GB Cartridge \$124.95
73836	Jaz 2GB Cartridge 3-Pack \$299.85

Modems	
60339	Teleport 56K V.90 Ext Fax/Modem for Mac \$77.98*
*After \$30 mfr. mail-in rebate. Low Zone Price \$107.98 Expires 8/30/99	
60313	3Com/USR 56K V.90 D/F for Mac \$79.97*
*After \$30 mfr. mail-in rebate. Low Zone Price \$99.97 Expires 8/28/99	
60385	SupraExpress 56K D/F for Mac \$89.98
617205	SupraExpress USB 56K Mac/PC Modem \$95.98
107099	Viking USB 56K V.90 Ext Fax/Modem \$107.98
108005	Teleport USB 56K V.90 Ext Fax/Modem \$118.98
95638	Viking 56K V.90 PCMCIA Card Modem \$129.98

we're open 24 hours a day 7 days a week

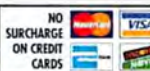

Credit cards are not charged until the order is shipped. Most products ship the same day (barring system failure, etc.). Shipping options include Ground, 2nd Day and Overnight delivery. Freight is based on average product weight. Handling extra. Insurance available. Special orders may require special shipping and handling charges. Call for international shipping rates. Prices and product availability subject to change without notice. Specials and promotions may be limited to stock on hand. Not responsible for typographical errors. All products sold by Multiple Zones International (MZI) are third party products and are subject to the warranties & representations of the applicable manufacturers, including but not limited to Y2K compliance. Accordingly, MZI makes no representation or warranty with respect to Y2K compliance of product sold. ©1999 Copyright Multiple Zones International Inc. All rights reserved. Unauthorized duplication is a violation of applicable laws. Apple, the Apple logo, Macintosh® and PowerBook® are registered trademarks of the Apple Computer, Inc.

G3 PowerBook!



FREE STUFF!
at www.zones.com/freestuff

\$100 Off any Purchase!

Get complete details online at www.zones.com/etrade

when you open an account with **E*TRADE**

20% Thinner and 2 pounds lighter!

NEW! PowerBook G3

333 & 400 MHz Features:

- Two USB ports
- FireWire capable*
- Mac OS 8.6
- 8MB VRAM
- S-Video/TV output for easy connection to a TV or a VCR
- ATI Rage LT Pro graphics accelerator for enhanced 2D and 3D graphics

- PLUS**
- 10/100 Base-T Ethernet port
 - 384MB max. system RAM
 - Built-in SCSI port
 - Integrated 4Mbps IrDA technology for easy wireless LAN access, printing and file sharing
 - Lithium-ion battery; support for dual-battery operation
 - 56K V.90 Modem
 - Hot-swappable expansion bay

*Optional FireWire CardBus Card



14" Active Matrix

Brand New from Apple!

Apple iBook **ONLY \$1594.98 EACH**

- Crunch-resistant polycarbonate case
- Battery life of up to six hours
- Weighs only 6.7 pounds

#110915 Apple iBook - Tangerine \$1594.98
#110916 Apple iBook - Blueberry \$1594.98
#110917 AC Power Adapter for iBook \$XX.98
#110918 Rechargeable Battery for iBook \$XX.98

Go Wireless!

iBook AirPort Base Station

- Surf the net or network with other iBooks wirelessly*
- 150' range lets you and the iBook roam around the home or classroom

*Requires the AirPort card

ONLY \$294.98 #110920
#110919 AirPort 42 Card ... \$99.98

MAC ZONE EXCLUSIVE!

Purchase ANY PowerBook & get **\$40 OFF** PowerPrint USB

ONLY \$53.98* #108100

*with PowerBook purchase. Low Zone Price \$93.98. Excludes iBook

BACK-UP BONUS BUY!

Retrospect Express and Zip Disk - **FREE**

ONLY \$39.99 #108099

SAVE \$30!

Targus NotePac Nylon Power-Book Case #06023 **\$39.98**

Targus Premier Deluxe Leather Power-Book Case #07720 **\$158.98**

Memory Upgrades G3 PowerBook Series

UPGRADE	ITEM #	ONLY
32MB Upgrade	#05057	CALL
64MB Upgrade	#05059	CALL
128MB Upgrade	#05061	CALL

NEW! Apple® PowerBook® \$2494.98

G3/333MHz #108066

64MB RAM, 4.0GB HD, variable speed CD-ROM, 512K Backside Cache, 14.1" Display

4-Year Laptop Plan with Screen Protection! \$449.98 #97595

NEW! Apple® PowerBook® \$3494.98

G3/400MHz #108067

64MB RAM, 6.0GB HD, DVD-ROM, 1MB Backside Cache, 14.1" Display

4-Year Laptop Plan with Screen Protection! \$459.98 #107107

Special Buys • Prices Updated Every Day • Major Brands

PowerBook Essentials

07157 Targus Leather Notebook Case	\$99.98
07173 Samsonite Notebook System Case	\$39.98
07175 Samsonite Notebook Compact Case	\$32.98
42245 Kensington Saddle Bag for PB G3 (bk)	\$69.98
07159 VST Internal Zip Drive	\$239.98
06421 Kensington Security Cable	\$39.98
57714 HP 3400ci Portable Inkjet Printer	\$329.98
45690 Konaxx Mobile Connector	\$119.98
20634 Virtual PC 2.1 Windows 98	\$168.98
07159 VST G3 Zip Drive	\$239.98
82633 PB Universal SCSI Adapter	\$30.98
00116 Norton AntiVirus 5.0	\$63.98
81849 DAVE 2.1	\$119.98
00642 PowerPrint 4.5	\$94.98
86331 Focus TView Gold	\$399.98
86677 Apple Remote Access Client	\$49.98
06231 ACT!	\$149.98
04890 Norton Utilities 4.0	\$94.98
89379 Kensington Mouse 1.0	\$59.98

03765 Road Rocket	\$289.98
08640 BookEndz	\$199.98
88753 AirDock	\$64.98
55677 IREZ Capture zoomed video PCMCIA	\$109.98
55678 KriiterKam	\$239.98
44546 VST Auto Adapter	\$78.98

Input

75112 MacAlly Two Button Mouse	\$24.98
87464 Kensington Mouse in a Box	\$39.98
03727 Kensington Keyboard in a Box	\$49.98
89379 Kensington Mouse 1.0	\$59.98
637021 Asanté FriendlyNet USB 4 Port HUB	\$39.98
102688 Belkin USB 3-button Mouse (iMac blue)	\$14.99
78420 Kensington Orbit	\$69.98
87483 Kensington Turbo Mouse 5.0	\$99.98
85553 Address Touch Extended Keyboard	\$39.98
31933 MacAlly iKey Extended USB Keyboard	\$39.98
85594 Address Tri-Form Ergo. Keyboard w/Touchpad	\$89.98
75109 MacAlly Port Xpander 3 to 1	\$58.98

3-Year Extended Service Plans for Laptops

\$701-1200	\$284.98	\$3001-4000	\$338.98
\$1201-2000	\$304.98	\$4001-5000	\$351.98
\$2001-3000	\$322.98	\$5001-10,000	\$406.98

3-Year Extended Service Plans

\$0-350	\$97.98	\$2001-3000	\$221.98
\$351-700	\$120.98	\$3001-4000	\$259.98
\$701-1200	\$156.98	\$4001-5000	\$278.98
\$1201-2000	\$198.98	\$5001-10,000	\$352.98

Visit Zones.com for your **FREE OS 8.6 DOWNLOAD**

Deals are going fast at the Zones.com Auction Site
Bids begin at just **\$1.00!**

Corporate bids welcome!
Fax to 1-800-684-8080
A NASDAQ COMPANY Ticker Symbol: MZON

Source Code **MW9010**

Order by Phone **1.800.436.0606**

Order Online Today **Zones.com**



the next generation of



QuarkXPress 4.0 Comp. Upgrade

Work faster and smarter!



ONLY \$298⁹⁸
#104526

Casady & Greene Conflict Catcher 8



ONLY \$72⁹⁸
#91300

UMAX PowerLook III Scanner



ONLY \$895
#102871

Entrega 4-Port USB Hub

Connect USB peripherals!



ONLY \$56⁹⁸
#30039

Keyspan Serial to USB Adapter

Add external Serial devices to your Power Mac!



ONLY \$78⁹⁸
#37060

Lexmark 310 USB Laser Printer

The first USB-ready laser printer!



ONLY \$364⁹⁸
#104877

Apple Int. 56K V.90 Faxmodem for G3



\$89⁹⁸ FREE
#102936

*when you open an eTRADER account.
Product shown is representational only.

Adaptec Internal SCSI Card

Adds an external SCSI port to your new Power Mac!



ONLY \$59⁹⁸
#99498

What you'll find at Zones.com: Hot New Products • Online Auctions

Monitors	
94187	Princeton E0505 15"13.8" Monitor \$169.99
08622	Princeton Ultra 72 17"15.8" Monitor \$209.97
78590	Princeton E0705 17"15.9" Monitor \$245.98
76514	ViewSonic GS771 17" Monitor (16" View) \$339.97
101437	NEC MultiSync A500+ 15" Monitor \$189.98
75914	ViewSonic Optiquest 071 17" Monitor \$239.98
76501	ViewSonic E771 17" Monitor \$239.97
629257	Princeton Ultra 95 19"18" Monitor \$394.97
03581	ViewSonic PS790 19"18" 25" SM 1600 \$559.97
75914	ViewSonic Optiquest 071 17" Monitor \$429.98
75956	ViewSonic Optiquest 051 15" Monitor \$155.97
46794	Sony Multiscan 500PS 21" Monitor \$1099.97
110250	Htachi CM640U-RO 17"15.9" 23" Monitor \$269.99
46793	Sony Multiscan 400PS 19" Monitor \$669.98
110251	Htachi CM811U-RO 21"20" 22" Monitor \$899.98
104838	Princeton E0930 19"18" Monitor \$479.97
76535	Htachi Mc7515 19"18" 22" Monitor \$539.98
84147	ViewSonic G810 21" Color Monitor \$819.97
78588	Princeton E0210 21"20" 1" Monitor \$858.98

Printers	
31720	Epson Stylus 740 \$249.98
107815	Epson Stylus 740 USB \$279.98
00576	Epson Stylus 850 \$299.98
107503	Epson Stylus Photo 750 USB \$299.98
107818	Epson Stylus Photo 1200 USB \$499.98
40920	Epson Stylus 1520 \$499.98
76985	Epson Color 3000 \$1299.00
108859	HP DeskJet 812C USB Printer \$199.98
102363	HP DeskJet 882C USB Printer \$299.98
60236	HP DeskJet 895Cse Printer \$399.98
617646	HP LaserJet 4050N Printer \$1389.00
57728	HP LaserJet 5000N Printer \$1999.00
60296	HP LaserJet 4500N Color Printer \$2399.00
77917	Tektronix Phaser 840 Plus Color Printer \$3195.00
76646	Tektronix Phaser 740 Color Laser \$1995.00
76087	Tektronix Phaser 740 Plus Color Laser \$2695.00
52851	Costar LabelWriter Turbo \$249.98
106579	Epson Stylus 3000 reconditioned \$899.98

Scanners	
58475	UMAX Astra 1220S SCSI Flatbed Scanner \$129.98*
*After \$20 mfr. mail-in rebate Low Zone price \$149.98	
Offer good through 7/31/99.	
622652	UMAX Astra 2000U \$129.99
18369	UMAX Astra 2400S \$299.98
31864	UMAX PowerLook III \$1195.00
18400	Microtek X6EEL Scanner \$239.98
104840	Microtek X6 USB Scanner \$129.98
97131	Microtek ImageDeck Stand-Alone \$478.98
75676	Epson Perfection 636 \$299.98
97188	Agfa 1212U Blue Scanner \$109.98
00540	UMAX Astra 1220S-P Transparency Adapter \$199.98
602610	Microtek SlimScan C6 USB Scanner \$89.98
97187	UMAX Mirage II Duo Advanced Scanner \$1995.00
90877	Microtek ScanMaker 4 Scanner \$669.98

Processor Upgrades	
PowerBook Upgrades	
03512	NuPower G3 250MHz 1/PowerBook 1400 \$999.98
03516	NuPower G3 240MHz 1/PowerBook 2400 \$849.98
Power Mac Upgrades	
60439	MAXpower G3 220MHz/110 \$449.98
60408	MAXpower G3 250MHz \$529.98
94400	MAXpower G3 333/166 \$1229.00
94403	MAXpower G3 366/183 \$1499.00
Power Mac G3 Upgrades	
94405	MAXpower G3 333/166 \$1229.00
94406	MAXpower G3 366/183 \$1499.00
94409	MAXpower G3 400/200 \$1999.00
Sonnet Technologies	
03524	Crescendo G3 266MHz \$599.98
03526	Crescendo G3 300MHz \$799.98
78928	Crescendo G3 PowerPC 333MHz \$999.98
78934	Crescendo G3 PowerPC 360MHz \$1199.00

we're open 24 hours a day 7 days a week

NO SURCHARGE ON CREDIT CARDS

Credit cards are not charged until the order is shipped. Most products ship the same day (barring system failure, etc.). Shipping options include Ground, 2nd Day and Overnight delivery. Freight is based on average product weight. Handling extra. Insurance available. Special orders may require special shipping and handling charges. Call for international shipping rates. Prices and product availability subject to change without notice. Specials and promotions may be limited to stock on hand. Not responsible for typographical errors. All products sold by Multiple Zones International (MZI) are third party products and are subject to the warranties & representations of the applicable manufacturers, including but not limited to Y2K compliance. Accordingly, MZI makes no representation or warranty with respect to Y2K compliance of product sold. ©1999 Copyright Multiple Zones International Inc. All rights reserved. Unauthorized duplication is a violation of applicable laws. Apple® the Apple logo, Macintosh® and PowerBook® are registered trademarks of the Apple Computer, Inc.

& Get FREE* Stuff!

FREE STUFF!
at www.zones.com/freestuff

*Shipping and handling charges may apply. Limited time offer.

Click here  **FREE Stuff!**
Hot New Products
Best Deals
Call or Click

Do all your shopping online! 

\$100 Off any Purchase! when you open an account with  **E*TRADE**

Get complete details online at www.zones.com/etrade

Buy a PowerMac G3 and get a **FREE**  **FREE** 

HP HEWLETT PACKARD HP 810 DeskJet Printer

OR 128MB Memory

Products shown are representational only. With mail-in coupons from Apple. While supplies last.

Pick the PowerMac G3 That's Right for You!

Now the most popular business Mac is at a new low price!

Apple® Power Macintosh® G3

350MHz Minitower

64MB SDRAM
6.0GB Ultra ATA-33 hard drive
24X Max. Variable Speed CD-ROM
1.0MB Level 2 backside cache

ONLY \$1594.98 #108086

OR LEASE FOR JUST \$56/Mo.

Visit Zones.com For the Latest Promotions!

Enjoy your favorite movies with the latest in DVD technology!

Apple® Power Macintosh® G3

400MHz Minitower

64MB SDRAM
6.0GB Ultra ATA-33 hard drive
DVD Drive
1.0MB Level 2 backside cache

ONLY \$1994.98 #108087

OR LEASE FOR JUST \$70/Mo.

Visit Zones.com For the Latest Promotions!

Included **omega® Zip Drive** is ideal for graphics professionals!

Apple® Power Macintosh® G3

400MHz Minitower

128MB SDRAM
12.0GB Ultra ATA-33 hard drive
24X Max. Variable Speed CD-ROM
1.0MB Level 2 backside cache

ONLY \$2494.98 #108088

OR LEASE FOR JUST \$88/Mo.

Visit Zones.com For the Latest Promotions!

The power you need for high-end media creation at the right price!

Apple® Power Macintosh® G3

450MHz Minitower

128MB SDRAM
9.0GB Ultra Wide SCSI-2 hard drive
24X Max. Variable Speed CD-ROM
1.0MB Level 2 backside cache

ONLY \$2994.98 #108089

OR LEASE FOR JUST \$106/Mo.

Visit Zones.com For the Latest Promotions!

New! **Adobe Photoshop 5.5**
The latest evolution of an industry standard!

UPGRADE \$109.98* #83084

Norton Utilities 2000
The tools you need for data recovery and disk repair.

NEW VERSION! ONLY \$44.98* #04890

*After \$70 rebate. Call for details. *After \$50 rebate for upgraders

Imation USB SuperDisk

Now 2X! \$169.98 -100 = \$69.98 #109035

*When you open an E*TRADE account.

Tektronix Phaser 840 GP Color Solid Ink USB

FREE Black Ink for life!

ONLY \$3899 #648962

VST External USB Floppy Drive

Use your old floppy disks (and files) with your new Power Mac G3!

ONLY \$89.98 #107094

USB Zip Drive

\$129.98 -100 = \$29.98 #95251

*When you open an E*TRADE account.

#37186 Zip Media (10 pk) \$79.98

Apple Studio Display 17"

ONLY \$494.98 #102932

Buy a 17" Apple Display with your new G3 and get \$100 Cash Back! (Print Apple Keyboard and mouse sold separately)

With Colorsync

Apple Studio Display 21"

ONLY \$1494.98 #102933

• Special Buys • Prices Updated Every Day • Software Downloads

UPS/Power	
00933 APC Back-UPS 200	\$89.98
00931 APC Back-UPS 300	\$99.98
00930 APC Back-UPS 500	\$149.98
00929 APC Back-UPS 650	\$229.98
00934 APC Back-UPS Office	\$84.98
55744 PK Electronic BlackoutBuster UPS	\$94.98
00923 APC Back-UPS Pro 280	\$149.98
00925 APC Back-UPS Pro 420	\$209.98
00926 APC Back-UPS Pro 650	\$269.98
88537 APC Back-UPS Pro 1000	\$359.98
26827 APC Back-UPS Pro 1400	\$459.98
55740 APC Smart-UPS 420	\$239.98
55741 APC Smart-UPS 620	\$309.98
07165 APC Smart-UPS 700	\$359.98
40410 APC Smart-UPS 1000	\$479.98
40411 APC Smart-UPS 1400	\$629.98
40419 APC Smart-UPS 1400 Rack Mount	\$699.98

Networking	
16630 AsanteTalk 10Base-T to LocalTalk Converter	\$79.97
Network Cards & Adapters	
607708 AsanteFAST 10/100 PCI Adapter	\$39.98
09414 AsanteFAST 10/100 PCI Adapter 5Pk	\$219.98
12009 AsanteFAST 10/100 PCI Adp 20Pk	\$798.97
102750 AsanteGigaNIC 10645X PCI Gigabit Card	\$899.98
12290 AsanteFAST 10/100 NuBus	\$224.99
101296 Asante MacCon CS 10T CommSlot	\$64.98
02505 Asante M0LC 10T LC PDS	\$74.98
102747 FriendlyNet PCMCIA 10T PC / MAC	\$69.99
600579 FriendlyNet PCMCIA 10T/TN PC/MAC	\$79.98
93330 Micro AsantePrint 10T Print Server	\$129.98
637021 FriendlyNET USB 4-Port USB Hub	\$39.98
Ethernet Standalone Hubs	
106517 FriendlyNET 5-port 10T Hub	\$39.97
106518 FriendlyNET 8-Port 10T Hub	\$49.98
106519 FriendlyNET 16-Port Desktop Hub	\$124.98

Fast Ethernet Standalone Hubs	
617933 FriendlyNET 5-Port 10/100 Hub	\$84.98
85151 FriendlyNET 8-Port 10/100 Hub	\$129.98
617934 FriendlyNET 16-Port 10/100 Hub	\$269.99
617935 FriendlyNET 24-Port 10/100 Hub	\$435.99
Fast Ethernet Switches	
617929 FriendlyNET 4005P 5-Port 10/100 Switch	\$139.98
617930 FriendlyNET 4005P 8-Port 10/100 Switch	\$199.98
617931 FriendlyNET 4005P 16-Port 10/100 Switch	\$559.98
617932 FriendlyNET 4005P 24-Port 10/100 Switch	\$799.97
600577 FriendlyNET 4004E 4-Port 10/100 Switch	\$199.97
600578 FriendlyNET 4004E 8-Port 10/100 Switch	\$399.97

Check out our Auction Site at Zones.com

Bids begin at just **\$1**



Corporate bids welcome!
Fax to 1-800-684-8080

A NASDAQ COMPANY Ticker Symbol: MZON

Source Code **MW910**

Order by Phone **1.800.436.0606**

Order Online Today **Zones.com**



the next generation of



GUARANTEED LOW PRICES!

Computer prices change all the time. If you find any item advertised for less in a current national catalog or publication, we'll match their in-stock price. Call for complete details.

- Order Online at Zones.com
- Order 24 hours a day, 7 days a week
- Serving Mac enthusiasts since 1986
- Publicly traded NASDAQ company: MZON
- Complete Mac product selection – call for products not listed!
- Affordable leasing options
- Tech Support and Customer Service
- 100% Apple "Learn and Earn" Gold certified sales staff!
- Sherlock Savvy!



Genuine HP quality for your Mac!



USB



NEW!
ONLY \$399.98
#60236

Premium performance with photo-quality color!
HP DeskJet 895C Printer

ONLY \$799.98
#102384

Sharper, faster and more expandable!



NEW!
The new workgroup standard!
HP LaserJet 4050N Printer

ONLY \$1389.97
#617964

Network color printing for workgroups!
HP Color LaserJet 4500N Printer



Organize in style!
Ultra-thin and ultra-light!
Palm V™ Organizer



NEW!
E-TRADE Sample Savings
~~\$429.98~~ **\$329.98**
#100100 when you open an ETRADE account

New 56K V.90 standard Teleport Modem!
Global Village Teleport 56K V.90 Fax/Modem



Our Best Selling Mac Modem!
E-TRADE Sample Savings
~~\$109.98~~ **\$100**
#60339 when you open an ETRADE account

ViewSonic® Maximum quality and a great value!
See The Difference!™



Optique Q91 19"
(18.0" viewable)
ONLY \$898.98
#110248
NEW!

Epson's fastest ink jet printer!
Stylus Color 900



ONLY \$449.98
#105493

SONY

Get high-performance and custom colors to match your iMac!
Spressa USB Ext. 4x/2x/6x CDRW



ONLY \$359.98
#609482

Tektronix FREE Black Ink for life!

Color printing has never been easier or faster!
Tektronix Phaser 840 GP Color Solid Ink USB



NEW!
ONLY \$3899
#648962

What you'll find at Zones.com: Hot New Products • Latest Offers

Business Software	
06231	Act! 2.8 iMac \$-49.98
93952	Adobe Acrobat 4.0 \$119.98
96676	Apple Remote Access Personal Server 3.0 \$-15.98
08329	AppleWorks 5.0 \$87.98
33357	Calendar Maker 4.5 \$48.98
74292	Consultant Contact Manager \$59.98
03972	Corel WordPerfect 3.5.1 \$-59.98
96801	Farallon Timbuktu Pro 4.0 Twin Pack \$-73.98
55866	MS Excel 98 Upgrade \$29.97
55870	MS Office 98 Upgrade \$249.97
55872	MS Office 98 Upgrade Gold Edition Mac \$329.97
55873	MS Office 98-Gold Edition Mac \$499.97
105073	MS Office 98-Mac \$419.97
04161	MS Project 4.0 - Mac \$389.97
55869	MS Word 98 - Mac \$332.97
55868	MS Word 98 Upgrade - Mac \$29.97
99042	MYOB Accounting Plus \$179.98
80532	Now Up-To-Date/Contact.Pblshr;Synze 3.65 \$86.98

Utilities	
87067	Micromat TechTool Pro 2.11 \$94.98
77998	Connectix Virtual PC 2.1 95 \$138.98
20634	Connectix Virtual PC 2.1 98 \$168.98
02077	Virex 5.9 \$54.98
90375	Speed Doubler 8 for Mac OS \$48.98
41956	Stuffit Deluxe 5.0 \$74.99
00555	Hard Disk Toolkit 2.5 \$122.98
32550	Connectix Triple Pack includes RAM Doubler 8, Speed Doubler 8, Surf Express Deluxe \$84.98
08285	Retrospect Express 4.1 \$44.98
91300	Conflict Catcher 8 \$72.98
00642	PowerPrint 4.5 \$94.98
84048	RAM Doubler 8 \$45.98
00116	Norton AntiVirus 6.0 \$23.98*
	*After \$40 mfr. mail-in rebate for upgraders.
04890	Norton Utilities 5.0 \$44.98*
	*After \$50 mfr. mail-in rebate for upgraders.

Games	
74181	Starcraft \$48.98
74149	ShangHai Dynasty \$39.98
72741	Carnaggedon \$29.98
34779	Myth 2: SoulBlighter \$44.98
49279	Diablo \$43.98
74846	Civilization 2 \$28.98
07420	Deer Hunter \$19.98
53467	Jack Nicholas 4 \$19.98
602810	Quake II \$47.98
53465	Real Pool \$16.98
07419	Unreal \$42.98
74166	Riven: The Sequel to MYST \$39.98
07427	Extreme Mac 12-Pack \$39.98
103788	Connectix Virtual Game Station \$48.98

Education	
90081	Bailey's Book House \$16.98
90082	Millie's Math House \$16.98
505005	KidDesk Internet Safe \$25.98
74177	Math Blaster Pre Algebra \$18.98
71251	Mavis Beacon Teaches Typing 9.0 \$36.98
80635	Family Tree Maker Deluxe II \$79.98
74199	Oregon Trail 3 \$39.98
77404	Design Your Own Home 3D Walkaround \$69.98
79710	Encyclopedia Britannica 1999 CD \$48.98
05984	Reunion 6.0: Family Tree \$99.98
604602	National Geographic 109 Years Collectors Ed. \$144.98
14163	Dr. Seuss Preschool \$17.98
06108	Arthur's Teacher Troubles \$17.98
07397	Where In The World Is Carmen Sandiego? \$27.98
90018	Learn To Speak Spanish 7.0 \$69.98

100s of games available...
if you don't see it listed, call!



Credit cards are not charged until the order is shipped. Most products ship the same day (barring system failure, etc.). Shipping options include Ground, 2nd Day and Overnight delivery. Freight is based on average product weight. Handling extra. Insurance available. Special orders may require special shipping and handling charges. Call for international shipping rates. Prices and product availability subject to change without notice. Specials and promotions may be limited to stock on hand. Not responsible for typographical errors. All products sold by Multiple Zones International (MZI) are third party products and are subject to the warranties & representations of the applicable manufacturers, including but not limited to Y2K compliance. Accordingly, MZI makes no representation or warranty with respect to Y2K compliance of product sold. ©1999 Copyright Multiple Zones International Inc. All rights reserved. Unauthorized duplication is a violation of applicable laws. Apple®, the Apple logo, Macintosh® and PowerBook® are registered trademarks of the Apple Computer, Inc.

Any Purchase!

when you open an account with  E*TRADE
Get complete details at www.zones.com/etrade

Do all your shopping online!

Click here 

Zones.com

- FREE Stuff!**
- Hot New Products
- Best Deals
- Call or Click

We Have the Mac Software You Want!

GRAPHICS

Adobe Publishing Collection
NEW SAVE OVER \$669
ONLY \$998.98 #108211

Includes PageMaker 6.5 Plus, Photoshop 5.5, Illustrator 8 and Acrobat 4.0

QUARK XPress 4.0 Competitive Upgrade
COMPETITIVE UPGRADE!
ONLY \$298.98 #104526

#613842 QuarkXPress 4.0 Full Version . \$699.98

Nova Print Explosion
NEW!
ONLY \$49.95 #104517

Painter 6.0 with Wacom Intuos Tablets
AS LOW AS \$549.95 SAVE \$50!
#110606 Painter 6.0 w/6"x8" Tablet \$659.95

COREL ScanMaster XGEL
CorelDraw 8 and Microtek ScanMaster XGEL DP Bundle
SAVE OVER \$359!
ONLY \$299.98 #108243

JUST ANNOUNCED!
Sound Jam MP Turn your Mac into a jukebox
NEW!
ONLY \$49.98 #637018

MACWORLD EXPO BEST OF SHOW! NYC 1999

UTILITIES

NORTON AntiVirus 2000
ONLY \$23.98* #00116

*After \$40 mfr. mail-in rebate. Low Zone price \$63.98.

SYMANTEC Norton Utilities 2000
NEW VERSIONS of both products
**After \$50 mfr. mail-in rebate. Low Zone price \$94.98.

NORTON Utilities
ONLY \$44.98** #04890

BUSINESS

Microsoft Office 98 Mac Edition Upgrade
ONLY \$249.97 #55870

#105073 MS Office 98. \$419.97

Connectix Virtual PC 2.1 w/Win 98
FREE UPGRADE TO 3.0!
ONLY \$168.98 #20634

INTERNET

Adobe Web Collection
NEW SAVE OVER \$249
ONLY \$998.98 #108213

Includes Adobe GoLive 4.0, Photoshop 5.5, and Illustrator 8!

macromedia Flash 4 Upgrade
ONLY \$119.98 #77533

NEW VERSION!
#77532 Macromedia Flash 4 . \$279.98

Special Buys • Prices Updated Every Day • Software Downloads

Internet	
77533	Macromedia Flash 4 Upgrade \$94.98
72999	Dreamweaver Fireworks Studio \$388.98
07535	Dreamweaver 2 Upgrade \$127.98
73486	Macromedia Dreamweaver 2 \$288.98
104700	Fireworks 2 Upgrade \$124.98
59636	Fireworks 2 Full Version \$188.98
77546	Adobe ImageReady \$188.98
14182	Adobe ImageSlyer \$119.98
88414	Adobe PageMill 3.0 \$98.98
71964	NetObjects Fusion 3.0 Upgrade \$97.98
71940	NetObjects Fusion 3.0 Full Version \$199.98
71916	Adobe GoLive 4.0 \$289.98
76471	Bare Bones BBEdit 5.0 \$99.98
83320	Microsoft FrontPage \$139.98
71243	PANTONE ColorSuite for Internet \$74.98
71925	WebSpice Animations \$78.98
105118	WebSpice 2,000,000 \$78.98
71991	WebSpice Objects \$78.98

Graphics	
83084	Adobe Photoshop 5.5 Upgrade \$109.98
*After \$70 mfr. rebate for Photoshop 5.0 & ImageReady owners.	
88205	Adobe Illustrator 8.0 Upgrade \$119.98
71273	Adobe Graphics Studio \$899.98
103797	Adobe PageMaker 6.5 Plus Upgrade \$89.98
83930	Adobe Type Manager Deluxe 4.5 \$64.98
95334	Adobe Premiere 5.1 Upgrade \$189.98
84242	Macromedia FreeHand 8 Upgrade \$139.98
86007	Macromedia Director 7 Shockwave Internet Studio Upgrade \$479.98
92266	Director 7 Shockwave Internet Studio \$899.98
102870	Extensis Suitcase 8.0 Upgrade \$39.98
107669	Extensis Suitcase 8.0 Full Version \$89.98
71245	Extensis QXTools 4.0 Upgrade \$49.98
104539	Extensis PhotoFrame 2.0 \$189.98
72975	Extensis IntelligencePro 4.0 \$189.98
104522	MetaCreations Poser 4.0 \$239.98
104533	MetaCreations Painter 6.0 \$399.99

72905	MetaCreations Canoma 1.0 \$479.98
72905	MetaCreations Bryce 4.0 \$179.98
104517	Print Explosion NEW \$49.95
104508	Nova Art Explosion 525,000 \$149.98
71129	PANTONE ColorReady \$92.98
89657	PANTONE Color Survival Kit \$154.98
71241	PANTONE ColorSuite for Graphics \$229.98
72714	MacPublisher \$17.98
72974	Quarkimmedia 1.5 \$299.98
613842	QuarkXPress 4.0 \$699.98

Sherlock Savvy! Search Zones.com for everything Macintosh

Visit us online at **Zones.com** to see our full selection of products at the latest prices!



Corporate bids welcome!
Fax to 1-800-684-8080

A NASDAQ COMPANY Ticker Symbol: MZON

Choose 71 at www.macworld.com/getinfo

Source Code
MW910

Order by Phone
1.800.436.0606

Order Online Today
Zones.com



350-450MHz Power

Tektronix • JVC • Apple • Quark • Kodak • Iomega • PowerUser

Mac Cables & Adapters

Call us! We have everything you need!

POWERUSER

100MB Zip USB Drive

Only **\$129^{95!}**
DR9464

- Translucent blue
- USB compatible with your iMac!

Free! CD-R 5-pack with purchase of Zip Media 10-pack. Ask for item #AAA1017. While Supplies Last!

Gray 100MB Zip Disk 10-pack Item #BND3314 ONLY \$99.95

JVC GR-DVM70 Digital Video Cam

Only **\$1499^{95!}**
IN7863

- 10X Optical Zoom with 200X Digital Zoom with Spline Interpolation technology
- FireWire/DV Input/Output IEEE 1394 compliant
- 4:1:1 Digital Component Recording

QuarkXPress 4.0

Only **\$729^{95!}**
DTP0694

Precise layout tools and control over every aspect of your document!

Kodak DC265 Zoom Digital Camera

Only **\$899^{95!}**
IN7770

- 1536 x 1024 dpi resolution
- 3X optical/2X digital zoom lens
- USB and serial cables included
- 2.0" TFT color LCD • Audio record and playback
- 16MB compact Flash Picture card

Special Power Mac G3 Offers!



NOW UP TO 450MHz!

From MacWAREHOUSE, Get an...

Instant Rebate!
off regular MacWAREHOUSE prices.

OR

FREE! 64MB RAM

*\$29.95 installation fee required. See white box below for details.

PLUS! From Apple, Get a...

\$100 Rebate!

when you purchase a 17" Apple Studio Display and any qualifying Power Mac G3 together.**

**\$100 manufacturer's mail-in rebate. See white box below for details.

PLUS! From Apple, Get a...

FREE! 128MB RAM UPGRADE

OR

HEWLETT PACKARD DESKJET 810C PRINTER!

with the purchase of any qualifying Power Mac G3!

†Buy any qualifying Power Mac G3 and receive FREE 128MB of RAM or a FREE Hewlett Packard DeskJet 810C printer. RAM or printer will be sent to you direct from Apple. Allow up to 8 weeks for delivery. See white box below for details.

All above offers not valid on reconditioned models. Limited time offers. Call for details. Visit www.warehouse.com/rebate/apple for mail-in coupons, or call us at 1-800-390-0706 to request one.



Model shown is CPU1384.

Apple 17" Studio Display

Only **\$499!**
Item #MON0786

15.1" LCD Apple Studio Display

Only **\$1299!**
Item #MT2619

▲ 17" Studio Display

Apple 56K+ Internal Modem

56K modem with FaxSTF Software

Only **\$109^{99!}**
Item #DMD4229

†Capable of receiving at 56Kbps. Actual send and receive speeds may vary.



NEW! 128MB PC100 SDRAM G3 Memory

For New Power Mac G3s with 100MHz bus speed.

Upgrade Only **\$379^{99!}** each
Item #CHP0691

PAGE 1 OF 8

• Our sales staff is ready to take your order 24 hours a day, 7 days a week. We accept the following major credit cards: Visa, MasterCard, Discover Card/NOVUS, AmEx. Your credit card will not be charged until each item is shipped (no surcharge). CT, NJ and OH residents add applicable sales tax.

• Overnight delivery just \$9.95 per order up to 5 pounds. For all orders over 5 pounds, shipping is \$9.95 plus an additional \$1.75 per pound or fraction thereof. (Example: shipping for a 6 pound order is \$11.70). Please add an additional \$3.00 for all orders \$50.00 and under.

• Orders for "in-stock" items placed on weekdays up until 12:00 midnight (E), 10:00 pm (E) for Internet orders, ship same day for

overnight delivery (barring system failure, etc.). We anticipate being able to ship "out-of-stock" items within 30 days.

• All items we sell come with the MacWAREHOUSE 30-Day Guarantee Against Defects. Call our Customer Service Department at 1-800-925-6227 for a Return Merchandise Authorization (RMA) number within 30 days of the original invoice date. Defective software will be replaced immediately upon receipt of the defective product. Defective hardware will be replaced or repaired at our discretion, except for products from Apple 1-800-SOS-APPLE (1-800-767-2775), or Tektronix (1-800-835-6100). These manufacturers must be contacted directly, and will repair or replace products at their sole

discretion. Should you return hardware to MacWAREHOUSE from Apple or Tektronix, you will be assessed a 15% restocking fee which will be charged to your account. All returns are subject to the following: 1. All products must be returned in original packaging. 2. Shipping and handling charges are not refundable. 3. Software and consumables are not refundable unless returned unopened in original packaging with documentation. 4. Custom orders and cables are not refundable. 5. Products designated as "all sales final" are not refundable.

Copyright © 1999 Micro Warehouse, Inc. MacWAREHOUSE is a division of Micro Warehouse, Inc. Item availability and price subject to change without notice. We regret that we cannot be

responsible for typographical errors. All prices shown in U.S. dollars. Micro Warehouse makes no representations or warranties of any kind and assumes no liability concerning whether any of the products or services sold by us are Year 2000 Compliant. Year 2000 representations and warranties may be supplied directly to our customers by the manufacturers or publishers of certain products.



We accept these major credit cards.

Mac G3s prices starting at \$1599!

CALL FOR A FREE FULL-COLOR CATALOG!



Adaptec • Apple • Epson • AGFA • Nikon



Power Mac G3s up to 450MHz!

Monitor sold separately. Model shown is CPU1384.

All Power Mac G3s Feature:

- Up to a 450MHz PowerPC G3 processor
- Up to 128MB SDRAM (exp. to 1GB)
- Up to 12.0GB hard drive
- 24X max. variable CD-ROM drive or DVD-ROM drive (on model CPU1383/CPU1394)
- 1MB Backside Level 2 Cache
- ATI RAGE 128 graphics card with 16MB of graphics memory
- 10/100Base-T Ethernet
- Two FireWire ports
- 2 extra bays/4 PCI slots
- Mac OS 8.6

350MHz PowerPC G3/
64MB SDRAM/6.0GB HD/24X max. variable
CD-ROM drive/1MB Backside Level 2 Cache

400MHz PowerPC G3/64MB SDRAM/6.0GB HD/
DVD-ROM drive/1MB Backside Level 2 Cache

400MHz PowerPC G3/128MB SDRAM/12.0GB HD/24X max.
variable CD-ROM drive/Zip Drive/1MB Backside Level 2 Cache

450MHz PowerPC G3/128MB SDRAM/9.0GB Ultra2 SCSI HD/
24X max. variable CD-ROM drive/1MB Backside Level 2 Cache

POWER MAC APPLE CARE WARRANTIES**

- AppleCare Extended Service Plan begins immediately after your original warranty expires
- 100% parts and labor protection and unlimited repairs
- Quality service by authorized Apple-certified technicians
- Genuine Apple parts

1-year Extended Service Enrollment
WAR0475 **\$120**

2-year Extended Service Enrollment
WAR0480 **\$180**

**AppleCare Extended Service is not available to customers in the state of Florida.

Regular MacWAREHOUSE Price | Price with FREE* 64MB RAM

Lease!! for as low as \$47/mo. ¹	\$1599 Item #CPU1382	\$1628⁹⁵ Item #CPU1393
Lease!! for as low as \$58/mo. ¹	\$1999 Item #CPU1383	\$2028⁹⁵ Item #CPU1394
Lease!! for as low as \$73/mo. ¹	\$2499 Item #CPU1384	\$2528⁹⁵ Item #CPU1395
Lease!! for as low as \$87/mo. ¹	\$2999 Item #CPU1385	\$3028⁹⁵ Item #CPU1396

*\$29.95 installation fee required.

Agfa 1212u Scanner

Only **\$99.95!***

after MacWAREHOUSE \$30 rebate with the purchase of an iMac or Apple Power Mac G3. Item #IN7951.

*Translucent blue! • 36-bit color • USB
*Price before mail-in rebate. \$129.95. Rebate coupon available at www.warehouse.com/rebate/snapsan, or ask for coupon #AA1429. While supplies last. Offer expires 9/30/99.



Epson Stylus Color 900 Printer

New Low Price!
Only **\$399.95!**
PR14811

- 12ppm black; 10ppm color
- 1440 x 720 dpi
- Optional networking

EPSON



Nikon CoolPix 950 Digital Camera

Only **\$949.95!**
IN7755

- 2" color LCD • 3X optical zoom
- 2.11 million pixel resolution
- 8MB compact flash stores up to 128 standard images

Nikon



Adaptec PowerDomain 2930U Ultra SCSI Adapter



Only **\$99.95!**
DRI3165

- 20MB/sec. transfer rate
- Internal & external connectors
- Bootable

adaptec

NEW Phaser 840GP Solid Ink Printer

Tektronix
Only **\$3995!**
PR15354

- 10PPM color/1200dpi
- 128MB RAM
- 10/100Base-T
- ColorSync ready



PAGE 2 OF 8

1-800-355-5841 ★ www.warehouse.com/md

ORDER TOLL-FREE 24 HOURS A DAY, 7 DAYS A WEEK! CANADA ORDERS CALL: 1-800-603-5139

MacWAREHOUSE EXPRESS DELIVERY OVERNIGHT!

In-stock items, call weekdays by midnight (E), or order online weekdays by 10pm (E).



Hi, I'm Ken. Call me for more great deals!

Your #1 Source for Mac™ Systems and Products—since 1987!



Mac**WAREHOUSE**

FREE[†] 64MB RAM Upgrade

Broderbund • Apple • Iomega • Hewlett Packard • Umax • Kensington • Sony • Entrega

Virtual PC 2.1 with Windows 98

Fully integrated with Mac OS 8 and OS 8.5!

Free!

upgrade to Virtual PC 3.0 when you buy Virtual PC 2.1 now!



Connectix

COM1039: Virtual PC 3.1 with Windows 98 Full Version.....\$169.95
COM0951: Virtual PC 2.1 with Windows 95.....\$149.95
*\$9.95 shipping and handling. Offer direct from Connectix. See coupon on box for details.

Iomega Zip® USB Value Pack

Only **\$229.95!**
BND3035

Includes:

- Translucent blue Zip drive
- 10 color disks
- Carrying case
- Disk caddy
- Media wallet



NEW! HP DeskJet 882c Color Printer

Only **\$299.95!**
PR14684

- USB compatible only
- 9ppm black; 6.5ppm color
- PhotoRET II technology



iMac USB Hubs

As low as **\$59.99!**
DEH4075

- Provides 4 to 7 additional USB ports for expanding your peripherals.
- Matching iMac color case

DEH4075: USB 4-port Bondi-Blue.....\$59.99
DEH4727: USB 4-port Blueberry.....\$59.99
DEH4074: USB 7-port Bondi-Blue.....\$99.99



Astra 1220u Duo Color Scanner

NEW LOW PRICE!

Was \$125.99
Now Only **\$99.95!**
IN7260

- 600 x 1200 dpi resolution
- 36-bit with 10-bit A/D converter



Available in all 5 colors!

iMac/333MHz

Only

\$1199![†]

each

The 333MHz iMac blows the doors off anything else on the information superhighway!



Blueberry



Grape



Lime



Strawberry



Tangerine

iDock 2, from CompuCable, expands iMac's connectivity. iDock is a swivel base with an integrated 4-port USB Hub, a 3.5" Floppy Drive, 1 ADB Port, plus 2 Apple Serial Ports. iDock is molded in "Ice" to match any iMac perfectly.

Includes 3.5" Floppy Drive!

NEW!



COMPUCABLE

\$259.99

Ask for item #DEH4620

See the complete line of G3s at www.apple.warehouse.com

Visit us at: buymacgames.warehouse.com

for our full selection of great games for the Mac!



[†] Leases are only available to business customers with approved credit on product orders where at least one product totals \$750 or more. Lease payments are based on a 48-month Fair Market Value Lease. Call today to see how you can qualify. Lease terms are subject to change.

IMAC G3 MEMORY

128MB SDRAM

Only

\$299.95!

each

Item # CHP0659

- 66MHZ
- 144 PIN SODIMM

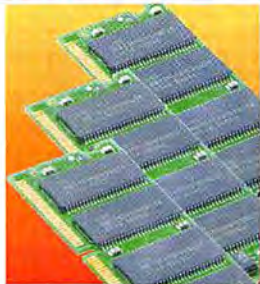

MYST

FREE*

with any purchase from MacWAREHOUSE Item # AAA0742

- Challenge your puzzle-solving skills in the Island world that is Myst!

Broderbund

*\$3.95 shipping and handling applies. Shipped in promotional packaging. Hurry! Offer good while supplies last. **Value based on MacWAREHOUSE pricing as of this magazine printing.



PAGE 3 of 8

ORBIT USB FOR MAC

Only **\$49.95!**

KENSINGTON

Ask for item #INP1761.

- Designed specifically for use with USB
- Fits the natural shape of your hand, ideal for right or left-handed users
- Manufacturer's 5-year warranty



HP DESKJET 895CSE PRINTER

Only **\$399.95!**

Ask for item #PR14208.

- 11ppm black
- 8.5 ppm color
- PhotoRet II technology
- 3000 page monthly duty cycle

HEWLETT PACKARD



SONY DIGITAL FD73 MAVICA

Only **\$499.95!**

SONY

Ask for item #IN7834.

- 10x optical zoom • E-mail mode
- 2.5" Color LCD • VGA resolution
- Quick Access 2X Floppy Disk Drive
- Picture effect • File copy/disk copy



for your iMac G3! only \$1199[†] ea.

See below for details.



Epson • Connectix • Imation • Farallon • Microsoft • Adaptec • Intuit

FREE[†] 64MB RAM UPGRADE!

from MacWAREHOUSE
when you
order your
333MHz
iMac today!

†\$29.95 installation fee
required. Limited time offer!
Does not apply to reconditioned
models.



Get a 333MHz
iMac for
only \$27.45
a month^{††}
Call for details.

- 333MHz G3 Processor
- Built-in 15" Color Monitor (viewable size: 13.8")
- 32MB (256MB max.)
- 6.0GB hard drive
- 512K Backside Level 2 Cache
- 6MB of Video RAM
- Built-in 24X max. variable CD-ROM drive
- Built-in 56Kbps Modem
- Built-in 10/100 Base-T Ethernet
- 2 USB Ports
- Mac OS 8.5

Regular MacWAREHOUSE Price:

Blueberry: item #CPU1336
Grape: item #CPU1337
Lime: item #CPU1338
Strawberry: item #CPU1339
Tangerine: item #CPU1340

\$1199! ea.

Lease!! for '35/month!

Price with FREE[†] 64MB RAM installed:

Blueberry: item #CPU1438
Grape: item #CPU1439
Lime: item #CPU1440
Strawberry: item #CPU1441
Tangerine: item #CPU1442

\$1228^{95!} ea.

Lease!! for '36/month!

Imation SuperDisk USB Drive

Only **\$169^{99!}**
DRI3350



- Now faster than ever! • 120MB capacity
- USB interface and hot-swappable

Imation LS-120 SuperDisks

Only **\$9^{99!}** each, in 10-pack with SuperDisk Drive purchase.
#BND3239

Farallon iMac iPrint Adapter with built-in PhoneNet!

Only **\$109^{99!}**
DEP1734



- Connects your iMac to LocalTalk printers and other Macintosh computers
- Easy plug-and-play installation

Ethernet iPrint Adapter for Stylewriter: DEP1739

\$109⁹⁹

Adaptec USB Connect 2000



Only **\$67^{95!}**
DAD1632



- Connect SCSI devices to your iMac in seconds
- DB25 and HD50-pin connections included!

Quicken 2000



Only **\$59^{95!}**
FIN1008

- Gain insight into your financial situation
- Easier than ever to use with improved interface!
- Access investment news, research and tools



MICROSOFT OFFICE 98



- Includes: Word 98, PowerPoint 98, Excel 98 and Outlook Express

Upgrade only
\$239^{95!}
Item # UPG0778



BUS1150: Microsoft Office 98 Full Version only \$399.95

EPSON STYLUS COLOR 740i PRINTER

Price: **\$279⁹⁵**

Manufacturer's mail-in rebate*: **-50***

Your final **\$229⁹⁵**
Cost:

- Comes in Blueberry or can be customized to match your iMac flavor
- 1440 x 720 dpi w/smaller ink drops
- 6ppm black; 5ppm color
- USB/Mac serial compatible

*Rebate coupon available at www.warehouse.com/rebate/epson, or call us at 1-800-390-0706 to request one. Offer expires 9/30/99.



Call for different color covers!

Microsoft Word 98 Special Edition

NEW!

Only **\$89^{95!}*** after \$30 rebate
WP3072



For iBook and iMac users only. Includes Word 98; thousands of clip-art images; greeting card templates, Internet Explorer 4.5; and Outlook Express 4.5.

*Price AFTER publisher's \$30 mail-in rebate. Before rebate: \$119.95. Rebate coupon in box.

1-800-355-5841 ★ www.warehouse.com/md

ORDER TOLL-FREE 24 HOURS A DAY, 7 DAYS A WEEK! CANADA ORDERS CALL: 1-800-603-5139

MacWAREHOUSE EXPRESS DELIVERY OVERNIGHT!

In-stock items, call weekdays by midnight (E) or order online weekdays by 10pm (E).



Hi, I'm Chris. Call me for more great deals!

Your #1 Source for Mac Systems and Products—since 1987!



Authorized Catalog Reseller

New! Apple iBook - Loaded

Apple • Newer Technology • VST • Global Village • Imation • 3Com US Robotics • Keyspan

Broderbund MYST **\$29.95** a value! **

FREE! with any purchase from MacWAREHOUSE AAA0742

Challenge your puzzle-solving skills in the Island world that is Myst!

*\$3.95 shipping and handling applies. Shipped in promotional packaging. Hurry! Offer good while supplies last.
**Value based on MacWAREHOUSE price as of this magazine printing.

USB Twin Serial Adapter

Only \$79.99! DAD1637

KEYSPAN

3Com Palm V Connected Organizer

Only \$399! BN6356

Clearer backlit display
Holds up to 5 years of appointments!

Palm IIIx Connected Organizer BN6334 \$329

Olympus D-400Z 1.3 megapixels

PRICE SLASHED!

Now only \$599.95! was \$699.95
IN7514

White supplies last.

- 1280 x 960 ppi resolution
- 3X optical lens
- 8MB Smartmedia card

OLYMPUS

SupraExpress V.90 Modem

Only \$99.99! DMD3503

Supports 56K* ITU standard V.90 & K56flex technology

*Capable of receiving data up to 56Kbps. Actual send and receive speeds may vary.

HP LaserJet Printers

HP LASERJET 8000N **Only \$2489.95!**
Ask for Item #PR13724. Lease!! for \$72/mo.*

- Prints 24ppm • 1200 dpi max. resolution
- 133MHz RISC processor

HP LASERJET 2100M
Prints 10ppm • 1200 dpi resolution • HP PostScript Level 2 • LocalTalk connectivity

HP LASERJET 2100 SERIES BLACK TONER CARTRIDGE **Only \$109.95 ea.** Item #PA1871

HP LASERJET 8000 SERIES BLACK TONER CARTRIDGE **Only \$179.95 ea.** Item #63223

HP LASERJET 4050N **Only \$1399**
Ask for Item #PR14947. Lease!! for \$41/mo.*

- Prints 17ppm
- 1200 dpi maximum resolution
- 100MHz RISC processor
- Ethernet 10BaseT/10Base2 + LocalTalk

HP LASERJET 8100N
Prints 32ppm • 1200 dpi • Item #PR14315 Lease!! for \$82/mo.* **\$2809.95**

HP COLOR LASERJET 8500N
Prints 24ppm blk/6ppm color • 600 dpi • Item #PR14213 Lease!! for \$184/mo.* **\$6359.95**

HP LASERJET 8500 SERIES BLACK TONER CARTRIDGE **Only \$219.99 ea.** Item #PA1662

HP LASERJET 8500 SERIES BLACK TONER CARTRIDGE **Only \$109.99 ea.** Item #PA1644

HP LASERJET 4050 SERIES BLACK TONER CARTRIDGE **Only \$94.95 ea.** Item #PR13025

HP LASERJET 5000 SERIES BLACK TONER CARTRIDGE **Only \$169.99 ea.** Item #PR13742

HP LASERJET 2100M **\$779.95!** Item #PR14691 Lease!! for \$24/mo.*

HP LASERJET 4050N **Only \$1999.95**
Ask for Item #PR13443 Lease!! for \$58/mo.*

VIEWSONIC P810 21" MONITOR

ViewSonic on top

- 21" (20" viewable) screen
- .25mm dot pitch
- 1600 x 1200 resolution @ 75Hz
- Manufacturer's 3-year warranty

Only \$979.95! Item #MON0668

IONEGA JAZ 2.0GB CARTRIDGES

jaz 2GB

Only \$99.95! ea., in 3+ quantity
Item #MED0508

Free CD-R 5-pack when you buy 1 Jaz 2.0GB cartridge! Limit one per customer. While supplies last. Item #AAA1017.

Quantity	1-2	3+
Price per disk	\$124.95 each	\$99.95 each

OMNIPAGE PRO 8.0 UPGRADE

FREE! Adobe PhotoDeluxe 2.0 when you buy OmniPage 8.0.

HURRY, WHILE SUPPLIES LAST!

- Optical character recognition (OCR) software enables you to quickly and easily convert scanned pages into computer editable documents.

Upgrade Only \$89.95! Item #UPG1023

*Adobe PhotoDeluxe shipped in promotional packaging.

NEW VERSION! Norton Utilities 5.0

- Prevents computer disasters
- Optimizes hard disk performance
- Helps prevent crashes, and speeds recovery from emergencies.

Upgrade Only \$49.95!* after \$50 upgrade rebate. Item #UTI1546

*Price AFTER publisher's \$50 mail-in rebate. Before rebate: \$99.95. Rebate coupon in box.

PAGE 5 OF 8

IMATION CD-Recordables

74 min. • 650MB • Jewel cases included

\$119* each, after rebate
only Ask for Item #ME8007.

\$10 Rebate! on 10-pack

*Price for 10-pack before manufacturer's mail-in rebate: \$21.99. Download coupon at www.warehouse.com/rebate/imation. Limit 3 rebates per name or mailing address. Offer expires 12/31/99.

3Com U.S. Robotics V.90 56K FaxModem

Only \$117.99! Ask for Item #DMD3448

LIFETIME WARRANTY

*Capable of receiving data up to 56Kbps. Actual send and receive speeds may vary.

Free Nova Software 3,000 Images** with the purchase of 2 Inkjet cartridges.

Amazon Inkjet Cartridges

As low as \$15.99! each, in 2-pack

Ink cartridges for Epson Stylus Photo and PM700 (1 blk/1 color): Item #BN6064, 2-pack only \$31.99.

Ink cartridges for Epson Stylus Color 400/600 (1 blk/1 color): Item #BN6066, 2-pack only \$31.99.

Ink cartridges for Epson Stylus Color 800/850/1520 (1 blk/1 color): Item #BN6065, 2-pack only \$33.99.

**While supplies last.



and Ready to Go! **\$1599!** ea.

Hewlett Packard • ViewSonic • Iomega • Olympus • Caere • Amazon • Targus



NEW! Apple iBook—

Packed with power, and wrapped in a stunning notebook design!

Only **\$1599!** each

Leasell! for \$47/mo.¹
Blueberry: Item #CPU1463
Tangerine: Item #CPU1464

Available in **Blueberry or Tangerine!**

- 300MHz PowerPC G3 processor
- 512K Backside Level 2 Cache
- 32MB SDRAM • 3.2GB IDE hard drive
- 24X max. variable CD-ROM
- 56K V.90 modem • 10/100 Base-T Ethernet
- Wireless networking with optional AirPort card and base (sold separately) • 12.1" Active-Matrix Display • ATI Rage Mobility 2D/3D Graphics Accelerator with 2X AGP
- USB port
- 4MB Video Memory
- Lithium-ion battery—up to 6 hours of use!

VST Zip 100 Drive

Only **\$229⁹⁵!**
DR10799
 Internal

For New G3 PowerBooks (CPU1359, CPU1360)

NEW!

• Hot swappable—no need to sleep, shut down, or restart.



VST TECHNOLOGIES

Targus Notepac Plus Black Carrying Case

Only **\$59⁹⁵!** each
AC19972



TARGUS

Call for other cases!

PowerBook G3 Battery

As low as **\$139⁹⁵!**
ACC3728



• Lithium-ion
 ACC3728 (fits new 1999 models) \$139.95
 ACC3307 (fits 1998 models) shown, \$199.95

Apple PowerBook G3s as low as **\$2499!**

The fastest Apple PowerBook G3s Ever!

These PowerBook G3s—with speeds up to 400MHz—run up to twice as fast as comparable Pentium® and Pentium II processor-based notebooks, based on BYTEmark integer index processor scores! **What's more, the new Apple PowerBook G3s are now almost 20% thinner and nearly 2 pounds lighter than their predecessors!**

333MHz PowerPC G3 processor/64MB SDRAM/4.0GB IDE HD/24X max. variable CD-ROM/56KModem/ 14.1" Active-Matrix Display/512K Backside level 2 cache/8MB SDRAM Video Memory

ASK FOR ITEM #CPU1359. Leasell! for **\$73/mo.¹ \$2499**

400MHz PowerPC G3 processor/64MB SDRAM/6.0GB IDE HD/DVD-ROM/56KModem/ 14.1" Active-Matrix Display/1MB Backside level 2 cache/8MB SDRAM Video Memory

ASK FOR ITEM #CPU1360. Leasell! for **\$102/mo.¹ \$3499**

Up to 10 Hours of Battery Life!

Almost 20% Thinner!

Nearly 2 lbs. Lighter!



32MB POWERBOOK G3 MEMORY UPGRADE

Upgrading your memory is the most cost-effective way to increase the performance of your system!

32MB PowerBook G3 Memory only **\$99⁹⁵!** each

Item #CHP9820



POWERBOOK G3 DVD-VIDEO KIT

- DVD-ROM drive reads CD-ROM discs up to 12X, DVD at up to 1.5X
- DVD-Video PC Card
- DVD player software
- Works with 1998 PowerBooks

Only **\$499⁹⁵!**

Item #DRI3206

While supplies last.



56K* V.90 FaxModem PC Card

Only **\$149⁹⁹!**
DMD3824



• K56 Flex and V90 technology

• Send, receive, view, print, and manage faxes right from your PowerBook

*Capable of receiving data up to 56Kbps. Actual send and receive speeds may vary.

FireWire 2 Go

Add FireWire to your PowerBook G3!

Only **\$239!**
DRI3505

NEW!

Fits in CardBus slot



newer technology

NEW! Adobe InDesign

Apple • 3Com • Hitachi • Global Village • Sony • Iomega • Microtek

Olympus C-2000 Digital Camera

Only **\$999^{95!}**
IN7788



- 2.1 Megapixel
 - 1600 x 1200 resolution
 - 3X optical zoom
 - 8MB SmartMedia Card included!
- Print out your digital photos on the new Olympus P330 Stylus Photo Printer
PR14784 **\$399.95**

32MB SmartMedia Cards

Only **\$129^{95!}**
MY11858



- Digital film for digital cameras
- Compatible with new digital cameras with SmartMedia slot

Microtek ScanMaker 4

Only **\$599^{95!}**
IN8094



- 36-bit color
- 600 x 1200 dpi
- Built-in transparency bay
- 8.5" x 14" scanning area

74 Minute CD-Recordables

Only **\$189!**
In 30+ qty.
ME7553



- Branded single with Jewel Cases
- 650MB capacity

3Com Palm III with Mac Pac version 2 Software

Only **\$229!**
BN6359



Store thousands of addresses, appointments, and more!

PAGE 7 OF 8



Apple 333MHz iMacs

Only **\$1099!** each

Apple Power Mac G3 350MHz Minitower



- 350MHz
- 64MB SDRAM
- 6.0GB HD
- 24X max. variable CD

Only **\$1399!**
Ask for item #RCPU1382.

Power Mac G3/ 400MHz/64MB SDRAM/ 6.0GB HD/DVD ROM: RCP1383 **\$1799***
Power Mac G3/400MHz/128MB SDRAM/ 12.0GB HD/24X max. variable CD/Zip Drive RCP1384 **\$2199***

Many other reconditioned Power Mac G3 models available. Call for details.

APPLE 333MHZ IMACS: 5 COLORS TO CHOOSE FROM!

- 333MHz PowerPC G3 processor
- 32MB SDRAM (256MB max.)
- 6.0GB hard drive
- 24X max. variable CD
- 56K modem
- 15" color monitor

Lime: Item #RCPU1338
Grape: Item #RCPU1337
Tangerine: Item #RCPU1340
Blueberry: Item #RCPU1336
Strawberry: Item #RCPU1339



Blueberry, shown.
only **\$1099!** each

POWER MAC 7100/80MHZ

- 80MHz PowerPC 601 processor
- 16MB RAM (exp. to 136MB)
- 500MB HD • 4X max. variable CD

Only **\$399!**
Item #RCPU1356

RCP10036: Power Mac 6100/66MHz, 16MB RAM, 230MB HD, 4X max. variable CD only \$399*

*Reconditioned system. Reconditioned computers may not include original application software. 90 day parts and labor warranty. All sales final. While supplies last. Monitor and keyboard sold separately.



APPLE POWERBOOK 5300c/100MHZ

- 100MHz PowerPC 603e processor
- 24MB RAM • 750MB HD
- 10.4" Active Matrix Color Display

Only **\$799!**
Item #RCPU1455

RCP10079: PowerBook 3400c/200MHz, 16MB RAM, 2.0GB HD, 6X max. variable CD, 33.6 Modem Display, 12.1" Active Matrix Color Display only \$999*

*Reconditioned system. Reconditioned computers may not include original application software. 90 day parts and labor warranty. All sales final. While supplies last.



HITACHI MC6405 17" MONITOR

HITACHI

- 17" monitor (15.9" viewable)
- Resolutions up to 1152 x 870 @ 75Hz
- 22mm horizontal pitch
- Manufacturer's 3-year warranty

Only **\$289^{95!}**
Item #MON0826



SONY 420GS 19" MONITOR

SONY

- 19" monitor (18" viewable)
- 1600 x 1200 resolution @ 75Hz
- Manufacturer's 3-year warranty

Only **\$589^{95!}**
Item #MON0762



FREE* CD-R 5-pack when you buy 1 Jaz 2.0GB cartridge.

Jaz 2.0GB Cartridges

Only **\$99^{95!}** each, in 3+ quantity

Ask for item #MED0508.
Quantity: 1-2 \$124.95 ea. 3+ \$99.95 ea.

*Limit 1 per customer. While supplies last. Ask for item #AAA1017.

NEW!

Epson Stylus Photo 1200 Printer

Only **\$499^{95!}**

Ask for item #PR15097

- 1440 x 720 dpi • Prints up to 13" x 44"
- Mac serial and USB compatible
- Includes Adobe Photoshop 5.0 LE



Global Village 56K* Teleport Internal Mac Modem

Only **\$109^{99!}**

Ask for item #DMD4267

*Capable of receiving data up to 56Kbps. Actual send and receive speeds may vary.



for as low as **\$299^{95!}** * See below for details.

CALL FOR A **FREE FULL-COLOR CATALOG!**



Olympus • Epson • Newer Technology • Sony • Adobe • Macromedia

Adobe InDesign

Professional page layout with seamless integration of Adobe products!

QuarkXPress, Adobe Photoshop, Illustrator and PageMaker owners: Get Adobe InDesign for only **\$299⁹⁵** Ask for item #SID0426.

NEW!

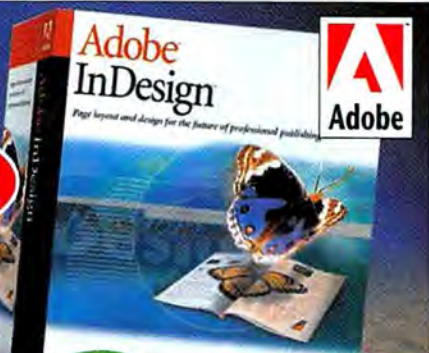

NEW VERSION! Adobe Photoshop 5.5

- Multiple undo: Quickly undo or redo several steps.
 - Magnetic Tools: Precisely follow the edges of an image.
- Adobe Photoshop 5.5 Upgrade (from Photoshop 5.0 or ImageReady 1.0) UPG1049 \$109.95*
- Adobe Photoshop 5.5 Upgrade (from Photoshop 4.0 or earlier) UPG1049 \$179.95
- Adobe Photoshop 5.5 (Full Version) GRA2951 \$599.95

Upgrade as low as **\$109⁹⁵** after rebate

Free! Silvertone 1.5 Extended Process Separator (by Intense Software)

with purchase of Adobe Photoshop 5.5. Ask for item #AAA1020. This Photoshop plug-in enables 6-color separations. *\$3.95 shipping and handling applies. Shipped in promotional packaging on CD-ROM. HURRY! While supplies last. †Value based on MacWAREHOUSE pricing as of this catalog printing.

A **\$249** Value!

NEW! Adobe Collections!

Publishing Collection (Photoshop 5.5, PageMaker 6.5 Plus, Illustrator 8.0.1, and Acrobat 4.0.) Item #GRA2975 **\$949⁹⁵**

Web Collection (Photoshop 5.5, GoLive 4.0, and Illustrator 8.0.1) Item #COM1215 **\$949⁹⁵**

Adobe Design Collection (Photoshop 5.5, InDesign 1.0, Illustrator 8.0.1, and Acrobat 4.0.) Item #GRA2974 **\$1299⁹⁵**

Macromedia FLASH 4



UPGRADE ONLY \$119^{95!} UPG1044

Fusing vector graphics, bitmaps, motion, MP3 audio, form input, and interactivity, Flash 4 delivers fast, Steering files, consistently and efficiently reaching all your sites visitors. Serial number of previous version required at time of order. Full version only \$279.95! Item #COM1166

Sony Digital FD83 Mavica

MPEG/Voice recording modes included



Only **\$699^{95!}** IN7856

- XGA resolution 1024 x 768, 1216 x 916 interpolated
- 3x Optical Zoom/Ex Digital
- 4x High speed floppy disk
- Audio & Video out • 2.5" LCD

Adobe Acrobat 4.0

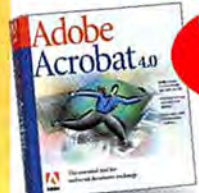

Upgrade only **\$89^{95!}** UPG0992 (CD)

The essential tool for universal document exchange!

Full version only \$229.95! Item #COM1128

G3 MEMORY UPGRADES

SAVE UP TO \$180⁺ when you also buy Adobe InDesign

NEW G3 128MB 100MHz SDRAM **\$199^{95*}** Item #AAP0612

G3 128MB 66MHz SDRAM **Only \$199^{95*}** Item #AAP0611



*Savings based on MacWAREHOUSE prices as of this magazine printing. *Memory must appear on same invoice as Adobe InDesign to qualify for this price. Offer valid between 5/3/99 and 11/1/99 or while supplies last.

NEXUS 128

- Rage 128 accelerator
- Supports up to 1900 x 1200
- 32MB memory

Only **\$279!** Item #DRI3236



MAC OS 8.5

- Sherlock Finder
- Internet Explorer 4.0
- Outlook Express — send/receive e-mail from home, work, or school

As low as **\$89^{95!}*** Item #SYS0292

*Price AFTER MacWAREHOUSE \$10 Internet mail-in rebate. Before rebate: \$99.95. Limit one rebate per customer (or total of 5 rebates per customer site.) Rebate coupon is available at www.warehouse.com/rebate/applesoftware, or call us at 1-800-390-0706 to request one. Offer valid through life of product.



NEW! Mac OS 8.6 Free download available at <http://warehouse.com/os86>

WWW.WAREHOUSE.COM

Get a **FREE*** gift when you order online.

Every time you order from our full line of Mac products on the Web, you can get one of these **FREE***: MYST, Hot Door Transparency or Collect Pro.

*\$3.95 shipping and handling applies. Limit one per customer per order. Shipped in promotional packaging. While supplies last.

See our **BLOWOUT SPECIALS AND SUPER OFFERS — every day!** Place your order online by 10:00 pm (E) and get it the next day!

Extended On-Site Support

Six great reasons to get complete system coverage:

1. Toll-Free Technical Help
2. Fast On-Site Support with next business day response in most areas for most items!
3. Free Replacement if unit cannot be repaired!
4. No Deductible — 100% coverage on parts and labor!
5. 24-36, and 48-Month Coverage available from date of purchase!
6. Fully Insured — Program underwritten by an "A-Excellent" rated insurer

Service you can depend on! Support and repairs administered by NWC which has been providing superior, price-competitive programs for over 20 years!

Cost of Computer and/or Peripherals	Warranty Price (48 months)	Ask for Item #
\$701 - \$1,200	\$219	WARD001
\$1,201 - \$2,000	\$269	WARD002
\$2,001 - \$3,000	\$309	WARD003

Call your Account Manager for details on orders over \$3,000.

Call your sales representative today!

*Note: This promotion, itself, is not a Service Agreement, but an outline of coverage available by National Warranty Corporation. Please call Micro Warehouse, Inc. for information and read the complete Service Agreement from NWC for exact coverages, terms, and conditions. On-site Support begins after the manufacturer's warranty expires. Plan not available on international or Florida orders. All returns not covered under the standard MicroWAREHOUSE return policy are subject to a \$25 return fee assessment.

1-800-355-5841 ★ www.warehouse.com/md

ORDER TOLL-FREE 24 HOURS A DAY, 7 DAYS A WEEK! CANADA ORDERS CALL: 1-800-603-5139

MacWAREHOUSE EXPRESS DELIVERY OVERNIGHT!

Your #1 Source for Mac Systems and Products—since 1987!

In-stock items, call weekdays by midnight (E), or order online weekdays by 10pm (E).



Hi, I'm Jason. Call me for more great deals!

Two Stylish

Get an extra 64MB RAM FREE* with iMac!

333MHz iMac with 96MB RAM!

Get an extra 64MB RAM FREE* with iMac!

Processor and Memory

- 333MHz Power PC G3 Processor
- 512K backside level 2 cache on processor module
- 133MHz dedicated 64-bit backside bus
- 66MHz system bus
- Integrated floating-point unit and 64K on-chip level 1 cache (32K data and 32K instruction)
- 32MB of SDRAM; two SODIMM slots support up to 256MB
- 64-bit memory bus

Connectivity

- Two high speed Universal Serial Bus (USB) ports (12 Mbps), which support USB devices such as keyboard, mouse, printer, storage devices, and USB hubs

Storage

- Internal 6GB IDE hard disk drive
- Internal 24X (maximum) CD-ROM drive

Communications

- Built-in 10/100BASE-T Ethernet
- 56Kbps modem supports K56flex and V.90 standards

Multimedia Capabilities

- Incredible, high resolution display... MultiScan, tilttable shadow mask color display: 15-inch (13.8-inch diagonal viewable image size), .28mm dot pitch
- Supports millions of colors at up to 1024 x 768 resolution (24-bit)

All models include:

- ▶ 333MHz ▶ 32MB RAM
- ▶ 6GB HD ▶ 56K Modem
- ▶ 24X CD-ROM

only **\$1,194** each

#46955 Blueberry #46954 Tangerine
#42841 Strawberry #42842 Lime #42839 Grape

Call for even lower price!

or **\$27⁴⁵** per month with our Apple Loan Program.
*A \$30 professional installation fee applies.

- ATI RAGE PRO TURBO accelerated 2D/3D graphics controller and 6MB video memory
- Refresh rate of up to 117Hz
- Outstanding audio features
- Built-in stereo speakers with SRS surround sound
- Built-in microphone
- Two front headphone jacks
- Minijacks for 16-bit CD-quality stereo input/output; 44.1-kHz sampling rate

Software

- Mac OS 8.5 pre-installed
- AppleWorks, Adobe PageMill, much more!

Visit macmall.com for more
USB
UNIVERSAL SERIAL BUS
peripherals.

Omega® Zip® 100MB USB Drive

Enjoy unlimited storage capacity and easy USB connectivity!

- ▶ Hot swappable
- ▶ Translucent blue

was \$149⁹⁹
\$99⁹⁹

#34314

With purchase of CPU after \$30 mail-in rebate. Limited time only.
For more info visit macmall.com



New Low Price!



Stylus® Photo 740i Printer

- ▶ New blueberry cover, and other optional colored cover available to match your iMac or iBook
- ▶ Ultra small ink droplets

\$229⁹⁹*

#48226

*Reg. price is \$279.99 - \$50 mail-in rebate = \$229.99.
Expires 9/30/99.

For more visit macmall.com

FREE cover to match your iMac w/CPU purchase!
Call for details.



MacMall Exclusive!

Ares USB Joystick

The most advanced USB joystick available today!

\$19⁹⁹

#44872

With purchase of iMac or G3.
Reg. price is \$39.99 #38338
While supplies last.

For more info visit macmall.com

Save \$20



Order Any Time! Open 24 Hours!
Order Today by 10pm EST—
Get it Tomorrow by 10:30am!

1-800-217-9492

Ways to Surf the Web!

iBook The portable iMac!

Blazing speed, dazzling design and fast, easy access to the Internet!

Freedom of movement!

With its convenient handle, the iBook just begs to be taken with you! Download your email and read it anywhere. Take it when you visit your friends so you can play the latest MP3 files off the Internet.

Outrageous performance.

- PowerPC G3 processor running at 300MHz
- 512K backside level 2 cache on processor
- 32MB of SDRAM; supports to 160MB RAM
- 3.2GB IDE hard disk drive
- Built-in 24X CD-ROM drive

Connectivity.

- One 12-Mbps Universal Serial Bus (USB) port
- Built-in 10/100BASE-T Ethernet
- Built-in 56K modem
- Optional AirPort wireless networking card

Advanced battery technology.

- Lithium-ion battery
- Up to 6 hours of battery life

Great graphics and video features.

- ATI RAGE Mobility graphics controller with 2X AGP
- 4MB SDRAM video memory
- 12.1-inch (diagonal) built-in TFT SVGA active-matrix display
- 800 x 600 resolution with millions of colors
- 16-bit stereo sound output minijack
- Single built-in speaker

Compact size.

- 13.5" x 11.6" x 1.8" average; depth ranges from 1.24" to 2.06"
- 6.6 pounds

Cool software.

- Mac OS 8.6
- Microsoft Internet Explorer
- AppleWorks
- World Book Encyclopedia
- Nanosaur and Bugdom 3D games

The iBook's case is a rugged polycarbonate, built to survive life in a backpack. It has no doors or latches to break.

Hours of power!

The iBook gives you over 6 hours of power on a single charge. When it's time to reenergize, just plug it in until the light turns green. Simple.

New!

FREE SHIPPING
on all online orders totaling over \$500!
Go to macmall.com

Up to 6 hours battery life!



With everything built in, the iBook is as Internet ready as a notebook can be!

\$1,594 ea.
only
#49199 Blueberry #49202 Tangerine

Free shipping is via UPS Ground for deliveries in the continental U.S. Offer expires 9/30/99.

iSee USB Digital Camera
with Colored Lens Kit
w/250K PXL Resolution
In every iMac and iBook flavor!
\$149⁹⁹
#48324
iRIS Delish!

HP DeskJet 812C USB Printer
6.5ppm black; 4.5ppm color
600dpi black
FREE colored cover with HP DeskJet 812C printer purchase!
Cover available in all iMac/iBook flavors!
HP DeskJet 812C USB Printer \$199⁹⁹
#47079

Introducing AirPort!
Transform your new iBook into a wireless Internet surfing machine.
AirPort lets you access the Internet with your iBook from anywhere in your home, office, dorm or classroom—without wires! No more hunting around for a phone jack every time you want to get online. If you're within 150 feet of the AirPort, you're connected! All you need is an AirPort card for your iBook and the AirPort Access Point.
AirPort also lets multiple iBooks access the Internet at the same time, transfer files, and of course, play multi-player network games!

#49221	AirPort Hardware Access Point	\$299 ⁹⁹
#49222	AirPort Card	\$99 ⁹⁹

Visit our Web site for the latest deals and best pricing!
macmall.com or AOL Keyword: Mac Mall
Mention your Priority Code: **#ZMWD9A1**



NEW Power Macs up to 450MHz!

Incredible new features packed into one great system!

The latest Macintosh G3 models come with a lightning fast processor up to 450MHz, ATI RAGE 128 graphics card, 2 USB ports and 2 FireWire ports designed

especially for connecting video devices like scanners and digital cameras. They are fast enough to handle the toughest video and publishing applications with ease.

Smart enough to grow with your needs. And sophisticated enough to make your computer time more enjoyable than ever.

A new standard in speed and design!

Outrageous performance.

- PowerPC G3 processor running at 350, 400 or 450MHz
- Supports up to 1GB of low cost, high performance PC100 SDRAM
- 1MB of performance-boosting backside cache running at up to 225MHz
- System bus running at 100MHz (instead of the 66MHz bus on earlier models) boosts performance speeds, reduces bottlenecks
- 6 or 12GB Ultra ATA hard disks or a 9GB Ultra2 LVD SCSI hard disk

- 24X CD-ROM drive or DVD-ROM drive with DVD-Video playback
- Built-in 10/100BASE-T Ethernet networking; optional Gigabit Ethernet

Advanced capabilities.

- Two high speed FireWire ports for digital video and still cameras, printers, scanners and other multimedia peripherals
- Two USB ports for keyboards, mice, printers—up to 127 devices at once
- Two additional bays let you store over 100GB internally (varies by model)

- Four PCI slots (three 64-bit slots and one 32-bit for ATI card)

Design elegance.

- Translucent case, inspired by the iMac
- Easy, drop down accessibility for installing cards, drives, and memory
- Convenient, built-in handles for easy carrying

Great graphics and video features.

- ATI RAGE 128 Graphics Accelerator provides incredible 2D/3D performance for graphics intensive games
- 16MB SDRAM video memory
- Built-in FireWire—allows you to transfer video directly from your digital video camera for digital editing with virtually no loss of quality
- Hardware acceleration of graphics and video
- Support for up to 1,600-by 1,200-pixel resolution at 32 bits per pixel (millions of colors) and up to 85Hz refresh rate
- Advanced integrated triangle setup engine
- Single-pass multi-texturing design

New Power Mac G3s!

Order	#47647	#47648	#47649	#47650
MHz	350	400	400 w/Zip Drive	450
RAM	64MB	64MB	128MB	128MB
HD	6GB Ultra ATA	6GB Ultra ATA	12GB Ultra ATA	9GB U2 LVD S
Cache	1MB @ 175MHz	1MB @ 200MHz	1MB @ 200MHz	1MB @ 225MHz
CD/DVD-ROM	24X CD-ROM	DVD-ROM	24X CD-ROM	24X CD-ROM
Price	\$1,594	\$1,994	\$2,494	\$2,994
Lease	\$56/mo.	\$70/mo.	\$88/mo.	\$105/mo.

Call for details on our new low lease rates!

EXTRA 64MB FREE!
Or instant Cash Rebate!
+ \$25 gift cheque.

EXTRA 64MB FREE!
Or instant Cash Rebate!
+ \$25 gift cheque.

EXTRA 64MB FREE!
Or instant Cash Rebate!
+ \$25 gift cheque.

EXTRA 128MB FREE!
Or instant Cash Rebate!
+ \$25 gift cheque.

VIKING COMPONENTS DON'T FORGET MEMORY!

Upgrades for your Power Mac

#42223	32MB PC100 DIMM	\$79 ⁹⁹
#42224	64MB PC100 DIMM	\$139 ⁹⁹
#42225	128MB PC100 DIMM	\$279 ⁹⁹
#42226	256MB PC100 DIMM	\$692 ⁹⁹

Have your RAM professionally installed by one of our factory-trained technicians, for only *30. Ask for #2214. See more Viking memory at macmall.com.

The New Apple 21" Studio Display with ColorSync!

- Combines lifetime color calibration with outstanding visual performance and appearance
 - 21-inch (diag.) Trinitron CRT; 19.8-inch viewable
 - 1600 x 1200 @ 85Hz
 - .25 to .27mm dot pitch
- \$1,499⁹⁹** #42244



For more info visit macmall.com

Get Stuffit Deluxe for only

\$24⁹⁹

#48604
with your MacMall CPU purchase after mfr. mail-in rebate.



For more info visit macmall.com

The World's First Desktop FireWire External Hard Drive Solution

NEW!

#43603	FireDrive HDD 8.4GB External Drive	\$349 ⁹⁹
#43604	FireDrive HDD 10.1GB External Drive	\$399 ⁹⁹
#43608	FireDrive HDD 14.4GB External Drive	\$459 ⁹⁹

For more info visit macmall.com



Order Any Time! Open 24 Hours!
Order Today by 10pm EST—
Get it Tomorrow by 10:30am!

1-800-217-9492

FREE Shipping



on all online orders totaling over \$500

Go to **macmall.com**



Monitor sold separately.



Visit **macmall.com** for more **USB** UNIVERSAL SERIAL BUS peripherals.

starting at only

\$1,594 #47647

Call for even lower price!
or lease for as low as

\$56 per month

Check out our Web site for the latest computer deals!

macmall.com

Free shipping is via UPS Ground for deliveries in the continental U.S. Offer expires 9/30/99.

New G3 Servers!

Fast and Easy Access to Everything Inside!

- Power PC G3 400 or 450MHz
- 128 or 256MB SDRAM (exp. to 1GB)
- One or two 9GB Ultra2 LVD SCSI hard drives
- 1MB level 2 cache
- 24X CD-ROM drive
- AppleShare 6.2; Mac OS 8.6

G3 Servers starting at **\$3,294**
Call for even lower price!



#47652	400MHz, 128MB RAM, 9GB HD, 24X CD-ROM	\$3,294
#47653	450MHz, 256MB RAM, (2) 9GB HD 24X CD-ROM	\$4,994
#47654	Mac OS X Server, 450MHz 256MB RAM, (2) 9GB HD, 24X CD-ROM	\$4,994

MacMall EXCLUSIVE!

Up to \$300 Instant Cash Back + \$25 in MacMall Gift Cheques!

Ask for #48938

All products in this catalog priced between

Product Price	Instant Cash Back	MacMall Gift Cheque
1594-2499	\$100	\$25
2500-2999	\$150	\$25
3000-3499	\$200	\$25
3500-4396	\$250	\$25
4397+	\$300	\$25

No coupons to mail in. No checks to wait for. Best of all, there is no limit — so order as many times you want, and keep saving! Cannot be combined with Free Memory promo. Gift Cheques are redeemable for merchandise only. No cash redemptions. Valid through 9/27/99. Limit one gift cheque per computer purchased.

FREE!

Up to 128MB RAM with your Power Mac® Purchase!
A \$279⁹⁹ Value!

\$30 installation fee applies. Cannot be combined with Instant Cash Back promo.



FREE!

Magazine subscription with computer purchase!
Call for details.



Visit our Web site for the latest deals best pricing!

macmall.com or AOL Keyword: Mac Mall

Mention your Priority Code: **#ZMWD9A1**

MacMall

The NEW Slimmer, Faster PowerBook G3s!

New G3 PowerBooks up to an incredible 400MHz!

The new PowerBook G3s are the sleekest, fastest, best-equipped notebooks ever! With the high-

performance G3 processor, they out-perform comparable Pentium and Pentium II processor-based desk-

top systems, with go-anywhere, do-anything PowerBook convenience!

Cutting Edge Features at an Affordable Price!

Processor and Memory

- 333 or 400MHz PowerPC G3 processor—fastest performance ever in a notebook!
- 66MHz system bus
- 512K or 1MB backside Level 2 Cache; 133 or 160MHz dedicated 64-bit backside bus
- Integrated floating point unit and 64K on-chip Level 1 cache (32K for data and 32K for instruction)
- 64MB RAM; 2 SO-DIMM slots support up to 384MB RAM

Storage

- Internal 4 or 6GB IDE hard drive
- 24X CD-ROM (#48336) or DVD-ROM drive (#48337) for use in expansion bay
- Removable 1.44MB floppy disk drive for use in expansion bay (sold separately)
- Hot-swappable expansion bay supports CD-ROM, DVD, Zip, SuperDisk or hard drive

Expansion & Networking Ports

- 2 USB ports, SCSI port, power adapter port

- Built-in 10/100BASE-T Ethernet
- RJ-11 modem port, 4Mbps Infrared (IrDA) port
- Support for a Zoom Video PC card
- PC Card Slot for one Type I or Type II card

Graphics, Video & Sound

- 14.1 inch (diagonal) display features built-in TFT XGA active matrix display, supporting millions of colors at 1024 x 768 resolution
- 8MB SDRAM video memory; supports millions of colors on external displays up to 21"
- 2D/3D graphics, through integrated ATI RAGE LT Pro video controller
- S-Video port
- 24-bit video output port (VGA-style connector)
- 16-bit CD quality stereo input/output
- Two built-in stereo speakers
- Internal omnidirectional microphone

Portability

- Kensington cable lock slot and keyboard lock

- Includes one Lithium-ion battery for up to 5 hours of normal use; supports two batteries for as much as 10 hours (depending on configuration and usage)

Software (Pre-installed)

- Mac OS 8.6, Apple File Synchronization, Apple Location Manager, Microsoft Internet Explorer, Microsoft Outlook Express, Netscape Communicator and FAXstf

Size and Weight

- Width: 10.4"; Height: 12.7"; Depth: 1.7"
Weight: 5.9lbs. (w/CD-ROM + battery installed)



Upgrades for your PowerBook G3

#31438	32MB PowerBook G3	\$69 ⁹⁹
#31440	64MB PowerBook G3	\$149 ⁹⁹
#31442	128MB PowerBook G3	\$299 ⁹⁹

Have your RAM professionally installed by one of our factory-trained technicians for only \$30. Ask for #2214. Visit our Web site: macmall.com for more Viking memory.

NEW USB PowerBook G3 Series!



Order	MHz	RAM	HD	Cache	Drive	Modem	Display	Price	Lease
#48336	333	64MB	4GB	512K	24X CD-ROM	56K	14.1" Active Matrix	\$2,494	\$88
#48337	400	64MB	6GB	1MB	DVD-ROM	56K	14.1" Active Matrix	\$3,494	\$122

Call for Even Lower Prices! Ask for details on our new low lease rates!

Essential Accessories

Make your PowerBook G3 totally portable with these Apple accessories!

#31413 Apple AC Adapter \$94⁹⁹

#47086 Apple Lithium-Ion Rechargeable Battery \$149⁹⁹



4 Port USB Hub

This low cost USB solution gives you 4 powered USB ports to connect all your peripherals. For keyboards, game controllers and more!

- Slips right into your carrying case



4-Port Mini Hub
\$29⁹⁹
#47702

For more info visit macmall.com

Internal Zip for your New 1999 PowerBook G3

- 100MB capacity per disk
- 11.2 MB/sec. transfer rate
- Share data w/millions of other Zip users



Internal Zip Drive for the NEW PowerBook G3
\$219⁹⁹
#47081

#47082 Internal SuperDisk Drive for the New PowerBook \$219⁹⁹
For more info visit macmall.com

For Your New PowerBook G3

- 1440 x 720dpi, 6-color (PRQ™) Quickdry inks
- Ultra small ink droplets (6 picoliters)
- Fast! Prints 4" x 6" photos in 1 minute
- USB, parallel & serial ports

Stylus® Photo 750
\$299⁹⁹
#44849

EPSON



For more info visit macmall.com

Order Any Time! Open 24 Hours!
Order Today by 10pm EST—
Get it Tomorrow by 10:30 am!

1-800-217-9492

FREE Shipping



on all online orders totaling over \$500

Go to **macmall.com**

The new features of the G3 PowerBooks include two USB ports and high-speed 10/100BASE-T Ethernet!

New Slimmer and Lighter Design!

- Super slim profile
- Only 5.9 lbs., nearly 2 lbs. lighter than previous models!



MacMall Exclusive Offers!

see below for details.



Authorized Catalog Reseller

starting at only

\$2,494

#48336

Free shipping is via UPS Ground for deliveries in the continental U.S. Offer expires 9/30/99.

Visit **macmall.com** for more **USB** UNIVERSAL SERIAL BUS peripherals.

MacMall EXCLUSIVE!

Up to \$300 Instant Cash Back + \$25 in MacMall Gift Cheques! Ask for #48938

All products in this catalog priced between

Product Price	Instant Cash Back	MacMall Gift Cheque
1594-2499	\$100	\$25
2500-2999	\$150	\$25
3000-3499	\$200	\$25
3500-4396	\$250	\$25
4397 +	\$300	\$25

or

FREE!

128MB RAM with your PowerBook Purchase!

\$30 installation fee applies. Cannot be combined with Instant Cash Back promo.



and

FREE!

Magazine subscription with computer purchase!

Call for details.



FREE!

carrying case with any PowerBook purchase!

While supplies last.



A \$60 Value!

No coupons to mail in. No checks to wait for. Best of all, there is no limit—so order as many times you want, and keep saving! Cannot be combined with Free Memory promo. Gift cheques are redeemable for merchandise only. No cash redemptions. Valid through 9/27/99. Limit one Gift Cheque per computer purchased.

Visit our Web site for the latest deals and best pricing!

macmall.com or AOL Keyword: Mac Mall

Mention your Priority Code: **#ZMWD9A1**

MacMall

If You Don't See it, Call

MacMall has the best prices on USB peripherals for the iMac™, iBook™, Power Mac and PowerBook G3!

<p>Canon Canon MultiPass C635 USB Multifunction New! Lets you print, copy, scan and fax! \$379⁹⁹ #49066</p> 	<p>Agfa SnapScan 1212u USB Scanner In translucent iMac & iBook Bondi Blue In translucent iMac & iBook Bondi Blue ▶ 36-bit > 9600dpi interpolated ▶ 600 x 1200dpi > Scans up to 8.5" x 11.7" \$99⁹⁹ #43359 with CPU purchase. Reg. price \$109.99.</p> 	<p>MICRO CONNECTORS, INC. Blueberry USB Upgrade Kit Includes hub, 6' cable, mouse and mousepad. All iMac/iBook colors available. \$59⁹⁹ #43777 with iMac or Power Mac G3 purchase. Reg. price \$79.99.</p> 	<p>VST TECHNOLOGIES External Floppy Disk Drive for the iMac ▶ Matches iMac and iBook colors ▶ Hot-swappable interface \$79⁹⁹ #46117 with CPU purchase. Reg. price \$99.99. Call for details.</p> 
<p>iQue! Drive 4x2x8 CD-Rewritable Drive for the iMac™ The revolutionary USB interface CD-Rewritable Drive ▶ Three drives in one ▶ Ideal for data archiving ▶ Excellent addition for MIDI and recording studios ▶ Translucent Blue \$299⁹⁹ #45035</p> 	<p>iSee USB Digital Camera w/Colored Lens Kit 250K PXL Resolution ▶ 320 x 240 ▶ 5 lenses from 3.6 to 8.0mm \$149⁹⁹ #48324 iRis Delish!</p> 	<p>HP DeskJet 812C USB Printer Match your iMac and iBook with Free Colored Cover! \$199⁹⁹ #47079 Reg. price \$279.99 - \$50 mail-in rebate = \$229.99. Expires 9/30/99.</p> 	<p>HP HEWLETT PACKARD Expanding Possibilities</p> 
<p>Entrega Hubs Available in all iMac and iBook colors! \$59⁹⁹ #48881 Call for details!</p> 	<p>Intuos 4 x 5 USB Tablet WACOM Professional Series Tablet ▶ 1,024 pressure levels \$199⁹⁹ #48998</p> 	<p>Agfa ePhoto CL30 AGFA ▶ 1440 x 1080 pixels w/Agfa PhotoGenie ▶ 4MB CompactFlash \$379⁹⁹ #43799 #32425 Kodak DC260 USB/serial digital zoom camera '899⁹⁹</p> 	<p>56K V.90 USB Modem BEST DATA \$84⁹⁹ #47014 W/FREE USB 4-Port Hub A \$50 Value! Offer valid until 9/30/99.</p> 
<p>zip 100MB lomega® 100MB USB Zip® Drive Enjoy unlimited storage capacity and easy USB connectivity! Easy to connect, hot-swappable, translucent blue. \$30 Rebate! w/CPU purchase. Price after rebate \$99. only \$129⁹⁹ #34314 Price does not reflect \$30 rebate.</p> 	<p>4/8GB USB Tape Drive aawa Add 8GB of storage to your iMac or G3! ▶ Up to 8GB storage (w/2:1 compression) ▶ Includes Dantz® Retrospect backup software \$239⁹⁹ #49174</p> 	<p>New! SuperDisk Drive! Twice as fast! Reads & writes both 120MB SuperDisk diskettes and standard HD 3.5" diskettes. \$169⁹⁹ #46876</p> 	

Palm V™ w/FREE MacPac™ 2.0 and Slim Leather Case
3Com
State of the art industrial design—smaller size, lighter weight and ultra thin!
\$426⁹⁹
#44046
And get a USB PalmConnect Kit for only \$39⁹⁹ \$488⁹⁹
FREE Palm V™ Slim Leather Case! While supplies last.



Optiquest V95
White Supplies Last!
\$424⁹⁹
#98294
▶ 19" (18" viewable)
▶ 1600 x 1200 res. @ 76 MHz
▶ .26mm dot pitch
▶ 3 year limited warranty



ORB External 2.2GB SCSI Removable Drive
CASTLEWOOD
▶ Faster than many hard drives
▶ 10ms seek time, 5400rpm
▶ Unlimited capacity with additional 2.2GB cartridge
▶ Ultra SCSI Interface
\$199⁹⁹
#44042
Limited quantities available—Reserve yours today!



Stylus Color 740 printer
EPSON
▶ 1440 x 720dpi
▶ 6ppm black
▶ 5ppm color
\$149⁹⁹
#48268
*Price reflects \$50 mail-in rebate. Exp. 9/30/99. Factory refurbished.



Ultimate Rez 2D/3D
128-bit 2D/3D video controller. Twin Turbo 128-3D and dual ported EDO VRAM! Includes card, driver and manual.
White Supplies Last!
\$79⁹⁹
#47690
Shipped in non-retail packaging.
ixTV for Mac and PC!
Interact with your TV on your desktop!
\$69⁹⁹
#46911



Order Any Time! Open 24 Hours!
Order Today by 10pm EST—
Get it Tomorrow by 10:30am!

1-800-217-9492

Us!



E-mail Specials!

Register now at macmall.com

for our weekly E-mail specials

and receive a

FREE gift!



Microsoft

Microsoft Word 98

Get the most out of your Mac with this limited time offer.

Special Edition for the iMac and iBook for only \$96⁹⁹

#49052

After \$30 mfr. mail-in rebate.

New!

The Future of Professional Publishing!

as low as **\$299⁹⁹**

#45630

- Seamless integration with Adobe Illustrator and Photoshop
 - Conversion of QuarkXPress 3.3-4.04 files as well as PageMaker 6.5 files
 - Create clipping paths automatically
- SAVE \$400** off the regular price if you own QuarkXPress, Photoshop, Illustrator or PageMaker! *Limited time offer.*

#45249 Adobe InDesign Mac/PPC \$699⁹⁹



Intuit

Quicken 2000 **New!**

Gives you more information and resources specific to your financial situation!

#48131

Call for details!



Adobe Photoshop 5.5

Photoshop is the standard for image editing, and new Photoshop 5.5 offers new creative tools and features especially designed for the Web.

- Perform complex masking tasks with increased precision
- Includes Adobe ImageReady 2.0 to create GIF animations and add Javascript Rollovers to Web pages
- Transform images with "painted" brush strokes
- Add special effects with a complete set of filters

Photoshop 5.5 upgrade as low as \$119⁹⁹

#47478

New!

Price reflects \$70 mfr. mail-in rebate for Photoshop 5.0 or ImageReady 1.0 customers.



Virtual PC 2.1 w/Win98

FREE upgrade to version 3.0! See macmall.com for details.



only \$168⁹⁵

#33446

Adobe Web Collection

Here are the core Adobe products you need to design sophisticated Web sites—all together for the first time in one suite: the full versions of Photoshop 5.5, Illustrator 8.0 and GoLive 4.0!

Save \$297!

\$949⁹⁹

#48276



New Norton Utilities for the Mac!



Version 5.0 is the safe way to repair disk problems and recover lost files.

New! \$44⁹⁹

#48932 After \$50 crossgrade mfr. mail-in upgrade rebate.



Hot New Mac Games!

Descent 3

More pulse pounding action as you fly out of mines to attack enemies on the planet's surface!

for only \$44⁹⁹

#47961



Connectix Virtual Game Station

Play many PlayStation games directly on your Mac!

only \$19⁹⁹

MacMall Exclusive!

#48961

with CPU purchase. Reg. price \$48.95.

Call for details!



Fly!

Total flight realism! Thrill to the most realistic flight simulator to date! Connect to the Internet and fly with your friends!

for only \$49⁹⁹

#47953



We do our best to be accurate, but occasionally mistakes occur. We are not responsible for any typographical, photographic or technical errors. Products and packaging may differ from stock available at time of shipment; we reserve the right to substitute equivalent items.

Introducing the

All New Mac Software & Accessories Buyers Guide!

Call For Yours Today!

1-888-425-MALL

Visit Our Online Catalog at software.macmall.com



MacMall Exclusive!

PaperPort Strobe™ Scanner

Scan anything from business cards to color magazine articles.

only \$69⁹⁹

#32976

SCSI Interface
Factory refurbished.
While supplies last.

PAPERPORT Strobe



400MB Zip® Kit

Kit Includes: Zip Drive (factory refurbished) four 100MB Iomega Zip Disks

\$99⁹⁹

#46932

1-year warranty.



New!

ePhoto 780C Digital Camera

- 1024 x 768 w/PhotoGenie
- 1.8" LCD screen
- Stores up to 96 photos on each memory card

\$199⁹⁹

#48140



SPECIAL!

56K V.90 External Modem

No Rebate Hassles! Save Today!

Get V.90 right out of the box!

\$59⁹⁹

#39443



24X External SCSI CD-ROM Drive

\$99⁹⁹

#37358

Special Offer!
While supplies last!



40X External SCSI CD-ROM Drive

\$129⁹⁹

#47204

Visit our Web site for the latest deals and best pricing!

macmall.com or AOL Keyword: Mac Mall

Mention your Priority Code: **#ZMWD9A1**

MacMall



Why trust your work



APS CD-RW 4x4x16

- 167% faster reads and 100% faster rewrites than CD-RW Pro 4x2x6
- The ultimate rewritable CD drive for professional environments

For serious content creation and distribution, the CD-RW 4x4x16 is the only CD drive you need. This tray-loading drive offers a 2MB buffer to prevent underruns and failed recordings. Plus, you get professional-level recording software for both Mac and PC.

Amazing Price! **\$299.95**
While Supplies Last

APS Pro Enclosure

LaCie USB CD-RW

- Hot-swappable, for quick moves
- Includes Toast software



The ideal USB storage solution for iMacs and G3s. This drive combines the power and flexibility of a rewritable CD drive with the hot-swappable ease of USB. Faster and larger than USB Zip and USB Superdisk drives, the LaCie USB CD-RW enables 650 MB CD production for inexpensive and easy file exchanges.

LACIE USB CD-RW **\$349.95**

External Configuration

APS CD-R/RW

APS CD-R 8x20 SCSI	349.95
APS CD-RW 4x4x16 SCSI	299.95
APS CD-RW 6x4x16 SCSI	399.95
APS CD-RW 8x2x20 SCSI	459.95

Drives on these pages are covered by the APS 30-Day Money-Back Guarantee.

Cruise over to our website at
www.apstech.com
for the most up-to-date prices

APS CD-RW 6x4x16

- Our fastest rewritable CD drive ever
- The ultimate CD drive for digital content creation and distribution

If you demand absolute top performance, this is it. The APS CD-RW 6x4x16 is our all-around fastest rewritable ever. Unheard-of speeds let you spend less time burning discs and more time creating. Includes professional CD recording software for both Mac and PC.

Fastest Ever **\$399.95**

APS Pro Enclosure

APS DVD-ROM

- World's first 5X DVD mechanism also acts as 32X CD-ROM drive

Now, you can play DVD movies, games, and entertainment titles, plus audio CDs and even CD-R and RW discs – all from the same drive. And this next-generation 5X drive gives you the smoothest playback ever.



w/Wired 4DVD **\$339.95**

Internal SCSI Configuration

Sony Spressa USB CD-RW

- 4X record/2X rewrite/6X read
- USB for hot-swap convenience and multidevice chains



- Excellent rewritable drive for creative types with new G3s, iMacs and USB PCs

Hot-Swap CD **\$359.95**

External Configuration



APS CD Mastering Systems

- Safely master on hard drive or Jaz disks before you burn your CDs
- Multifunctional 4x4x16 CD-RW drive

JazII/CD-RW 4x4x16 **\$849.95**
4GB/CD-RW 4x4x16 **\$749.95**
9GB/CD-RW 4x4x16 **\$899.95**



APS DupliCD Duplicators

- Stand-alone units give you one-button disc duplication – easy for even non-tech staff
- Faster readers and 4x8 CD-R dupes full a CD in just 18 minutes for better production
- Choose DupliCD-121 for single-disc duplication or 126 for six-disc duping

DupliCD-121 **\$999.95**
External Configuration
DupliCD-126 **\$2399.95**
External Configuration

CD DUPLICATORS

MediaForm CD-5900 8-Disc	\$7,399.95
MediaForm CD-5916 16-Disc	12,699.95
MediaForm CD-3704 100-Disc	7,599.95

to anything less than APS?

APS HyperDAT® II

- Up to 4GB of backup on one 120m DAT/DDS-2 tape
- New mechanism delivers 64% faster transfer rates than original HyperDAT

 If you run a fast-paced small business, or you oversee busy corporate workstations, the HyperDAT II cuts your backup times by 64% over the original HyperDAT II. Comes in our APS Pro enclosure with IC'E for top dependability. Includes your choice of backup software and a limited two-year warranty.

APS HyperDAT® II **\$649.95**
APS Pro Case



APS HyperDAT DDS-2

APS DVD-RAM

- Up to 5.2GB capacity on double-sided DVD-RAM discs
- Big enough to backup most hard drives, but with random access for fast file recovery
- Doubles as 20X CD reader and DV storage

 The APS DVD-RAM

puts a whole new spin on backup. This rewritable optical drive combines the capacity to backup most hard drives with the random access of a CD. So if you lose just a file or two, you can restore them in the blink of an eye. Or you can rebuild your entire hard drive from the 5.2GB disk. The APS DVD-RAM is also terrific for huge file storage, like massive graphics. This technology is even fast enough for digital video production and playback.

The APS DVD-RAM just may be the only drive, of any kind, that you ever need again. Call today.



5.2GB Rewritable **\$749.95**

APS Pro Enclosure

APS DLT 8000

- Next-generation DLT drive gets bigger, faster
- Perfect for content creation workgroup or departmental backup

 APS Tech is proud to introduce the next generation of DLT: the 40GB-native APS DLT 8000. But you get more than just greater capacity. Faster native transfer rates of up to 6MB per second make the APS DLT8000 the fastest backup solution on the planet. Supports UNIX, NetWare, Windows NT and Mac environments, so you can cover your whole network with one solution.



APS DLT 8000 **\$4,999.95**

External SCSI Configuration



APS DDS-2 Autoloader

- 64GB (compressed) for unattended backups
- Fast transfer rates of up to 50MB/min.

 An inexpensive backup solution for servers and small networks. Incorporating the Sony SDT7000 DDS-2 quad speed drive and eight-tape magazine, the APS DDS-2 Autoloader ships in a external full-height enclosure with seven 120m DDS-2 tapes and a head cleaner.

\$1,499.95

External SCSI Configuration

APS Tape Backup

APS NS-8	\$399.95
APS NS-20	499.95
APS HyperDAT® II DDS-2	649.95
APS HyperDAT® III DDS-3	999.95
APS HyperDAT® IV DDS-4	1,299.95
APS DLT40 DLT 4000	1,999.95
APS DLT70 DLT 7000	3,999.95
APS AIT PLUS	1,999.95
APS AIT II	3,999.95
APS AIT Plus Autoloader	2,999.95
APS DDS-2 Autoloader	1,499.95
APS DDS-3 Autoloader	2,999.95

Ships with Retrospect software.

APS MEDIA

CD-R / CD-RW DISCS

100421	650MB CD-R 10PK.	\$15.95
100422	650MB CD-R 100PK.	149.95
100423	650MB CD-R 250PK.	337.95
100424	650MB CD-RW 3PK.	24.95
100425	650MB CD-RW 5PK.	39.95
100426	650MB CD-RW 25PK.	189.95
100427	650MB CD-RW 50PK.	369.95

DATA TAPES - 4MM COMPATIBLE

100428	90M DDS-2 DAT 10PK. 2-4GB	\$49.95
100429	90M DDS-2 DAT 50PK. 2-4GB	225.95
100430	120M DDS-2 DAT 10PK. 4-8GB	99.95
100431	120M DDS-2 DAT 50PK. 4-8GB	499.95
100432	125M DDS-3 DAT 10PK. 12-24GB	219.95
100433	125M DDS-3 DAT 50PK. 12-24GB	1,149.95
100434	DAT CLEANING CART. 5PK.	34.95
100435	DAT CLEANING CART. 20PK.	119.95



Advanced tools for digital visionaries

Call 800-285-0638

24 HRS/7DAYS A WEEK

Corporate Sales (800) 554-3941
International (816) 920-4109





If you've got the

APS ST 18GB 10K Ultra2 Wide LVD SCSI

- Brand-new, third-generation Cheetahs offer even better performance and reliability
- 10,000 rpm and Ultra2 Wide LVD for multimedia, 3D, even digital video
- 18GB capacity for high-performance workstation and creative department/workgroup servers

 Get the ultimate performance from your content creation workstations and servers. These Cheetahs really scream, with up to 28MB/s internal data rates and super-low 5.2msec seek times. Third-generation technology and experience make this line more reliable than ever. For your next digital masterpiece, order an APS ST 18GB 10K today.



Maximum Power for Servers **\$949.95**
Internal Configuration

APS ST 36GB LVD SCSI

- Fifth-generation Barracuda 7200rpm for high-end image editing & graphic design
- Over 36GB of storage in convenient 3.5", half-height form factor

 Utilize this high-end hard disk drive as a creative image bank in the most demanding settings. Whether you are developing cinematography or complex 3-d imagery, the ST 36GB is an industry leader.

\$1,289.95
Bare Internal Configuration

APS ST 50GB LVD SCSI

- Fifth-generation Barracuda 7200rpm mechanism for super-stable server storage
- Over 50GB of storage in convenient 3.5", half-height form factor

 Now, you can have the biggest hard drive on the planet. This proven drive gives your high-volume workgroup and enterprise servers space to grow.

Blazing Enterprise Storage
\$1,599.95
Bare Internal Configuration

APS Ultra 160m / Ultra 2 Wide LVD SCSI Drives

Model	RPM	Bare	APS Pro
APS I 9GB LVD	7200	\$349.95	\$419.95
APS Q 9GB Ultra 160m L	7200	399.95	469.95
APS ST 9GB LVD	7200	429.95	499.95
APS I 9.1GB LVD 10K	10000	549.95	619.95
APS Q 9.1GB Ultra 160m LVD 10K	10000	569.95	639.95
APS ST 9.1GB LVD 10K	10000	539.95	609.95
APS I 18GB LVD	7200	699.95	769.95
APS Q 18GB Ultra 160m LVD	7200	729.95	799.95
APS ST 18GB LVD	7200	729.95	799.95
APS I 18GB LVD 10K	10000	949.95	1,019.95
APS Q 18GB Ultra 160m LVD 10K	10000	969.95	1,039.95
APS ST 18GB LVD 10K	10000	949.95	1,019.95
APS I 36GB LVD	7200	1,289.95	1,359.95
APS Q 36GB Ultra 160m LVD	7200	1,399.95	1,469.95
APS ST 36GB LVD	7200	1,279.95	1,349.95
APS Q 36GB Ultra 160m LVD 10K	10000	1,559.95	1,629.95
APS ST 36GB LVD 10K	10000	1,599.95	1,669.95
APS ST 50GB LVD	7200	1,599.95	1,669.95

Drives listed above carry a five year warranty.

* Bare configuration does not include a mounting bracket. Intended as a replacement internal SCSI drive.

How would you like to see your digital artwork published in an upcoming APS Tech catalog? Send an e-mail to marketing@apstech.com for details.

Surf on over to our website at www.apstech.com for the most up-to-date prices



APS ST 9GB Ultra SCSI

- Inexpensive 7200 rpm drive with Ultra SCSI interface
- 4 and 9GB capacities for workstation through server storage

 With this Medalist Pro-based drive, you can upgrade your file and print servers to 7200 rpm speed and keep your budget well under control.

\$319.95
Bare Internal Configuration

APS Ultra SCSI Drives

Model	RPM	* Bare	APS Pro
APS ST 4GB	7200	\$209.95	\$279.95
APS ST 9GB	7200	319.95	389.95
APS I 18GB	7200	699.95	769.95

Drives listed above carry a three year warranty.

APS IDE Drives

Model	*Bare
APS 10GB IDE	\$169.95
APS 20GB IDE	289.95



APS 36GB ShortStack Disk Array

- RAID Level 0 (Striping) for stunning speed in graphic design, imaging, digital video
- Perfect for graphic design, image editing, & digital video production
- Configured with two 18GB LVD 7200RPM Barracuda hard drives

RAID Speed for Digital Content Creation

\$1,199.95
External

passion, we've got the drive.

VST 10GB FireWire Hard Drive

- Ample hard drive with fast, hot-swappable FireWire/IEEE-1394 interface



- Great for multimedia/ digital video pros, graphic designers

 Forget device IDs, termination, power cables, and hassle. This 10GB FireWire drive offers hot-swapping to any FireWire-equipped Mac or PC. Perfect for transferring video and other huge files among workstations.

\$759.95
External

VST Zip Drives for Macintosh PowerBooks

- Add a full-function Zip drive to your expansion bay
- Acts just like a familiar, convenient floppy drive
- Stores 100MB on pocket-sized Zip disks

Now you can add the convenience of the award-winning Zip to your G3 PowerBook or a



3400/1400 notebook. Just pop a VST Zip into your extra bay. It is hot-swappable on a Macintosh PowerBook. VST Zip drives use standard, inexpensive Zip disks to store up to 100MB of data per disk. Perfect for the mobile businessperson, a notebook Zip lets you transfer large files from your desktop or workstation Zip drive and take them on the road. Or you can take your work home with you instead of staying at the office. Much faster than trying to send large files over the Internet or E-mail, Zip races through files at up to 1.4MB/s. And this drive only adds 10 oz. to the weight of your laptop. So if you spend a lot of time with your PowerBook, add Zip to it and take it on the road.

VST ZIP DRIVES

Model	Price
G3 POWERBOOK ZIP DRIVE	\$229.95
VST POWERBOOK 3400 ZIP DRIVE	249.95
VST POWERBOOK 1400 ZIP DRIVE	99.95

POWERBOOK ACCESSORIES

VST APPLE G3 CHG.	\$169.95
VST APPLE PB 3400 CHG.	149.95
VST APPLE PB 1400 CHG.	99.95
APPLE G3 LI-ION BATTERY	189.95
VST APPLE PBK 3400 LI-ION BATT.	159.95
VST APPLE PB 1400 NIMH BATT.	119.95
VST APPLE PB G3/3400/1400 AC ADAPTER	59.95
VST APPLE G3/PB 3400/1400 AUTO ADAPTER	79.95



APS Jaz II

- A staggering two gigabytes of removable storage transports graphics, multimedia
- Perfect for digital video professionals and service bureaus

\$439.95
External

MW
EDITORS' CHOICE

VST USB Floppy Drive

- The fast, inexpensive way to add a floppy drive to your iMac
- Compatible with any 1.4MB floppy - Mac or PC formats

APS is pleased to introduce the VST USB Floppy Drive. This lightweight, portable drive hooks up to your iMac in no time. And since the USB connection supplies the power, you don't need a separate, inconvenient power cable or AC adapter. So get the most out of your new iMac with the VST USB Floppy Drive. Call now.



VST USB FLOPPY \$99.95

REMOVABLE DRIVES

Model	Price
Iomega 250 SCSI	\$199.95
ORB 2.2GB SCSI	199.95
APS 640 MO SCSI	349.95
APS 5.2 GB MO	1,699.95
VST USB Floppy Drive	99.95
Imation USB Superdisk	149.95



Drives on these pages are covered by the APS 30-Day Money-Back Guarantee.

LaCie EKO 10GB USB

- Among the first hard drives with USB
- Easiest way to add over ten gigabytes of storage

 Adding more capacity to your desktop, workstation or server is a snap with this USB hard drive. It's hot-swappable; just hook it up and go.



Hot-Swappable \$299.95

EKO Enclosure
LACIE EKO 20GB USB \$499.95



Advanced tools for digital visionaries

Call 800-285-0638

24 HRS/7 DAYS A WEEK

Corporate Sales (800) 554-3941
International (816) 920-4109

APS Technologies • 6131 Deramus • Kansas City, MO 64120

MACWORLD October 1999 135



LaCie electron22Blue

- Brand-new 22" Diamondtron Natural Flat technology eliminates distortion and glare
- Mammoth resolution of 1800 x 1440 pixels at 80Hz for biggest layouts
- Five USB ports for the most advanced, convenient computing system ever

Introducing quite possibly the most advanced monitor ever for digital visionaries. This 22" display gives you outstanding color fidelity and perfectly geometrical images. No more distortion or straight lines that curve on screen. And the USB connections let you quickly swap USB devices like the LaCie USB CD-RW, new scanners, and more.

LACIE ELECTRON 22BLUE \$1,399.95
LACIE ELECTRON 19BLUE \$769.95

Wacom LCD Display Tablets

- Amazing tablets act as monitors – you draw and design directly on screen and work more intuitively
- Pressure-sensitive tablets (256 levels) include cordless Erasing UltraPens
- Must-have for cutting-edge graphics pros, animators, Web designers, multimedia



At APS, we are not easily impressed by new technologies. But Wacom has knocked our socks off. The new LCD Display Tablet line is like having the monitor screen on your lap or desk. You can design, illustrate, paint, animate and edit on-screen more accurately – to within 0.02 inches. We could say more, but you really have to see it to believe it. Be the first on your block to get a Wacom LCD Display Tablet. Call today.

WACOM PL-300 W/ 10.4" WORK AREA

\$2,199.95

PL-400 - 13.3" work area - \$2,999.95

Agfa DuoScan Solo Color Scanner

- Versatile scanner for creative departments, small firms
- Innovative TwinPlate for transparencies and reflective documents
- One-pass tri-linear CCD with 1000 x 2000 ppi resolution



The DuoScan handles all of your business scanning needs with ease, capturing images

from virtually any kind of document.

The built-in scanning bed for transparencies makes switching

between media types easier than ever. And the

DuoScan is fast. You will see your preview in just 11 seconds. And the DuoScan can deliver A4-sized color scans at 1000 ppi in just two minutes. So get high-quality scans for business documents fast with the DuoScan from Agfa.

AGFA DUOSCAN SOLO (MAC/PC) \$2,459.95

EPSON Stylus Color 900 Printer

- 1440 dpi and Micro Piezo technology for sharp details, no splatters
- Faster color printing (up to 10 ppm) makes you more productive



The new Stylus Color 900 lets even home and small businesses print corporate-class documents. And you can print color pieces faster than ever. So you spend less time waiting and more time drumming up business. Plus, with USB, parallel and Mac serial connections, you can use this image-maker with almost any computer. Get sharp, brilliant color fast and make a splash with the Stylus Color 900 from EPSON.

EPSON STYLUS COLOR 900 PRINTER \$429.95

APC Back-UPS Pro

- Extra surge suppression and longer runtime
- Safeguards data & equipment from lightning strikes and blackouts



Tape backup is critical to safeguarding your irreplaceable data. But it won't stop lightning from frying your motherboard. Back-UPS Pro, the ultimate workstation UPS, safeguards your data and equipment, like your CPU, drives, and monitor, against disasters like lightning strikes. And the uninterruptable power supply gives you time to save your files and shut down in case you ever lose power. Don't wait until it's too late. Get Back-UPS now.

CAT. #	ITEM DESC.	OUTPUT VA	CAP. WATTS	TYPICAL RUNTIME	BAT. OUTLETS	SURGE ONLY OUTLETS	DIMENSIONS (H" X W" X D")	PRICE
108355	BP280S	280	180	7-15 MIN	2	1	6.6 X 4.7 X 14.5	\$134.95
108356	BP420S	420	260	12-18 MIN	3	3	6.6 X 4.7 X 14.5	219.95
108357	BP650S	650	410	35-40 MIN	3	3	6.6 X 4.7 X 14.5	269.95
108717	BP1000	1000	670	10-15 MIN*	6	N/A	8.5 X 6.7 X 17.3	365.95
108714	BP1400	1400	950	15-20 MIN*	6	N/A	8.5 X 6.7 X 17.3	459.95

*With 3 computers connected.



dreams into digital reality.



Sony MVC-FD88 Digital Mavica Cameras

- Convenient digital cameras capture photos and video
- Store and transfer content on standard floppy disks
- Add images and multimedia to presentations, Web sites

The new FD88 grabs 1.3Megapixels for larger, print-quality images. You also get professional features like 3-mode auto exposure, manual exposure, flash and self-timer. To really get up close and personal, the FD88 offers 8X zoom capabilities. And you can record up to 15 seconds of presentation-quality MPEG video or 60 seconds for a video e-mail. Why not add some multimedia to your business? Pick up a Sony Digital Mavica Camera today.

SONY MVC-FD88 \$899.95
SONY MVC-FD83 \$699.95



Adaptec Ultra HotConnect 8945

- Connects both digital video camcorders and Ultra Wide SCSI devices to your computer using only one PCI slot
- Includes DV capture software, FireWire and SCSI cables/connectors

This PCI card lets you connect your digital video camcorder to your Mac or PC on the same slot as your SCSI drives. You can chain up to 62 IEEE-1394/FireWire devices and up to 15 SCSI devices, like Ultra Wide SCSI hard drives, CD recorders, Jaz and tape devices. This awesome package includes a complete set of SCSI and 1394/FireWire cables and connectors, plus digital video capture software.

ADAPTEC 8945 \$539.95

Canon ELURA Digital Video Camcorder

- Palm-sized DV Camcorder with Canon 12X optical/48X digital Zoom lens
- Noise reduction and Optical Image Stabilizer give you top quality footage

Now, you can get the power of digital video and the precision of Canon, all in the palm of your hand. The ELURA sports all of the advanced capture features of Canon's larger camcorders. You get crystal-clear digital video, with intricate details and true colors. The progressive scan CCD captures much better quality images than other, interlaced CCD camcorders. With up to 500 lines of horizontal resolution, you get 20% better-than-analog quality. Automatic or manual controls satisfy both the beginner and veteran. Plus, you can easily add your own personal touch to your video using the faders, effects, and a multi-image screen. So get the power of the Canon ELURA in the palm of your hand today.

CANON ELURA \$1,299.95



Sony DSC-D700 Digital Camera

- 1.5Megapixel images (1344 x 1024) for top-quality print projects
- 5X manual optical zoom, equivalent to f28mm to 140mm zoom lens on a 35mm camera
- Includes Type II PC Card and reader for easy transfer to desktop computer

Professional photographer for print? You may think that digital photography just doesn't have the quality or flexibility of your SLR camera. Well, now it does. Introducing the Sony DSC-D700 Digital Camera. This powerful device captures 1.5 million pixels per image to give you the kind of resolution you want for print. The DSC-D700 also gives you the control you are used to with your traditional camera.

You get a 5X optical zoom lens with a manual focus ring that feels familiar and professional. Choose between using the 2.5" color LCD screen or the viewfinder, depending on your situation. Advanced features include manual white balance, a center-weighted spot meter, auto/manual exposure, and a Hot Shoe for connecting an external flash with strobe lights. The pop-up flash comes in handy out in the field.



SONY DSC-D700 \$1,699.95



Advanced tools for digital visionaries

Call 800-285-0638
24HRS/7DAYS A WEEK

Corporate Sales (800) 554-3941
International (816) 920-4109
 APs Technologies • 6131 Deramus • Kansas City, MO 64120



Mac OS is a registered trademark of Apple Computer, Inc. APs and APs Technologies are registered trademarks. Other brand or product names are registered trademarks or trademarks of their respective holders.

- 30-day money-back satisfaction on all APs brand drives and accessories. Your risk is the cost of shipping.
- All major and 3rd party products carry warranties from their respective manufacturers.
- SCSI cables sold separately.
- APs warranty is a pass-through of the manufacturer's warranty which will be serviced by APs for one year. APs warrants APs branded enclosures, brackets and power supplies for a period of one year from the date of purchase and will, at its discretion, replace or repair products found to be defective according to the specific terms of the warranty accompanying the product.
- Returned orders subject to 20% restocking fee.
- International customers must pay for all shipping charges.
- Label capacities are formatted.
- Actual data compression and tape capacity vary greatly depending on the type of data recorded, other system parameters and environment.
- Prices and specifications are subject to change without notice.
- You must install system software appropriate to your machine before using our hard drives.
- Not responsible for geographical errors.
- Your APs Drive unit may contain one or more components that were in prior use, but which have been inspected and repaired or rebuilt as necessary. These components, if any, are covered by the same warranty provisions, exclusions and limitations to the same extent, and on the same terms as otherwise "new" components.
- © 1999, APs Technologies. All Rights Reserved.

Surf on over to
www.apstech.com
 for more multimedia tools

Your right to *selection*

Introducing the iBook—

*easy access to the Internet,
a choice of two colors,
tons of free software,
and a personality*

Apple® iBook™

- 300MHz PowerPC G3 processor
- 512K backside Level 2 cache
- 32MB RAM
- 3.2GB hard drive
- 24X Max CD-ROM drive
- 56Kbps (V.90) modem
- 10/100BASE-TX Ethernet
- Built-in 2D/3D ATI RAGE graphics with 2X AGP
- Mac OS 8.6
- 12.1" active-matrix SVGA display

Tangerine **\$1596.00** CDW 179139

Blueberry **\$1596.00** CDW 179140



Authorized
Catalog Reseller



Apple® AirPort

Wireless Internet connection for iBook

Apple AirPort Card

\$96.97 CDW 179146

Apple AirPort Hardware Access Point

\$298.68 CDW 179142



Apple® Power Macintosh G3 Series

- 350MHz PowerPC G3
- 1MB backside cache
- 100MHz system bus
- 64MB SDRAM
- 6GB Ultra ATA hard drive
- 24X Max CD-ROM drive
- 16MB video memory

\$1594.00
CDW 171054

- 400MHz PowerPC G3
- 1MB backside cache
- 100MHz system bus
- 64MB SDRAM
- 6GB Ultra ATA hard drive
- 5X/32X DVD-ROM drive
- 16MB video memory

\$1994.00
CDW 171055

- 400MHz PowerPC G3
- 1MB backside cache
- 100MHz system bus
- 128MB SDRAM
- 12GB Ultra ATA hard drive
- 24X Max CD-ROM drive
- 100MB Zip drive
- 16MB video memory

\$2494.00
CDW 171056

- 450MHz PowerPC G3
- 1MB backside cache
- 100MHz system bus
- 128MB SDRAM
- 9GB Ultra2 SCSI hard drive
- 24X Max CD-ROM drive
- 16MB video memory

\$2994.00
CDW 171057

Apple® iMac™

- 333MHz PowerPC G3 processor
- 15" display, 13.8" viewable, with 1024 x 768 resolution • 32MB SDRAM
- 6GB hard drive • 24X Max CD-ROM drive • 56Kbps modem • 10/100BASE-TX Ethernet • Two 12Mbps Universal Serial Bus (USB) ports • 6MB video memory
- Built-in stereo speakers with SRS sound

Only \$1194

Blueberry CDW 161620

Strawberry CDW 161623

Tangerine CDW 161632

Grape CDW 161627

Lime CDW 161634



MONITORS

APPLE

Apple Studio Display 17" (16" view) 0.25mm AG	499.00
Apple Studio Display 21" (19.8" view) 0.25-0.27mm AG	1499.00
Apple Studio Display LCD 15.1" (15.1" view)	1299.00

MITSUBISHI

Diamond Pro 900U 19" (18" view) 0.25-0.27mm AG	589.89
Diamond Pro 2020U 20" (20" view)	1286.50

PHILIPS/MAGNAVOX

105S 15" (14" view) 0.28mm	155.67
107S 17" (16.2" view) 0.28mm	239.97
108S 19" (17.9" view) 0.28mm	417.17

NEC

MultiSync A500+ 15" (13.8" view) 0.28mm	195.34
MultiSync A700+ 17" (16" view) 0.28mm	286.62
MultiSync E750 17" (16" view) 0.25mm	409.57
MultiSync E900+ 19" (18" view) 0.26mm	694.88
MultiSync P1250+ 21" (19.6" view) 0.28mm	969.52

SONY

100ES 15" (14" view) 0.25mm	199.76
200GS 17" (16" view) 0.25mm	439.02
400PS 19" (18" view) 0.27mm	679.53
500PS 21" (19.8" view) 0.26mm	1165.31

VIEWSONIC

GS771 17" (16" view) 0.27mm	309.22
G790 19" (18" view) 0.25mm	469.43
P810 21" (20" view) 0.25mm	874.68
PS775 17" (16" view) 0.25mm	399.45
G810 21" (20" view) 0.25mm	819.76
PS790 19" (18" view) 0.25mm	559.51
PT813 21" (20" view) 0.28mm AG	1007.16
P815 21" (20" view) 0.25mm	948.75

VIDEO BOARDS

ATI TECHNOLOGIES

ATI NEXUS GA 16MB	389.96
ATI RAGE ORION 16MB	174.67
ATI NEXUS 128 32MB	259.06
ATI XCLAIM 3D+ LCD 8MB	129.03
ATI XCLAIM VR 128 16MB TV	199.09

IX MICRO

Ultimate Rez 2D/3D 8MB PCI	309.92
ix3D Pro Rez 8MB PCI Power Mac	239.47
TV Tuner Card	99.11
Road Rocket PC Card	229.75

COMMUNICATIONS

GLOBAL VILLAGE

TelePort 56K V.90 external USB	119.30
TelePort 56K V.90 external	109.66
56K V.90 PC Card modem	144.99
TelePort 56K V.90 internal for the GS	109.18

3COM/U.S. ROBOTICS

Sportster 56K Fax/modem external	117.99
----------------------------------	--------

VIKING

Viking 56K V.90 Modem external USB	115.24
------------------------------------	--------

DATA STORAGE

IOMEGA

Zip drive 100MB external USB	129.95
Zip drive 100MB external SCSI	99.95
100MB Zip disk 3-pack	39.95
Zip drive 250MB external SCSI	169.95
250MB Zip disk 4-pack	69.95
Jaz drive 2GB internal	349.95
Jaz drive 2GB external	349.95
2GB Jaz disk 3-pack	299.95

LACIE

20GB external FireWire™ hard drive	499.00
4X4X16 CD-RW external w/PCI SCSI card	325.80
4X4X16 CD-RW external SCSI	329.00
CD-RW drive external USB	348.64
DVD-RAM external	749.00
2.6GB DVD-RAM disc single sided	29.74
5.2GB DVD-RAM disc double sided	42.27
4GB external SCSI hard drive d2 case	325.61
9.1GB external SCSI hard drive d2 case	429.00
9.1GB external SCSI hard drive d2 case	649.00
18GB external SCSI hard drive d2 case	809.06
36GB external SCSI hard drive d2 case	1899.00
10GB external USB hard drive	299.00
20GB external USB hard drive	449.00

QUANTUM

9.1GB Atlas III Ultra SCSI LVD	394.34
9.1GB Atlas III Ultra SCSI	394.34
18.2GB Atlas III Ultra SCSI	677.58
18.2GB Atlas III Ultra SCSI	719.43

IMATION

USB 120MB SuperDisk drive USB	169.99
-------------------------------	--------

SCANNERS

AGFA

SnapScan 1236S	199.00
SnapScan 1212U for the iMac	129.00
DuoScan T1200	609.67

EPSON

Perfection 636	299.00
Perfection 636U	229.00
Expression 800 Executive	699.00
Expression 800 Artist	799.00
Expression 800 Professional	999.00
Expression 836XL	2499.00

MICROTEK

ScanMaker 4	585.57
ScanMaker 9600XL	1388.22
ScanMaker X6	125.87
ScanMaker X6EL	197.87
ScanMaker X6 USB	118.79

NIKON

CoolScan III LS 30 film scanner	879.48
Super CoolScan LS 2000 film scanner	1814.63

POLAROID

Polaroid SprintScan 4000	1909.27
SprintScan 35LE film scanner	696.75

UMAX

Astra 1220S	149.00
Astra 2400S	249.00
Powerlook III	895.00
Powerlook III w/ transparency adpt	1195.00
Mirage II Duo Advance	1995.00

VISIONEER

OneTouch 7600 USB	139.77
Oneouch 5300 USB	106.89

PRINTERS

APPLE

LaserWriter 8500	1464.88
------------------	---------

EPSON

Stylus Photo 700	249.00
Stylus Photo EX	389.26
Stylus Color 740	299.00
Stylus Color 740i	279.00
Stylus Color 1520	499.00
Stylus Color 3000	1299.00

HEWLETT-PACKARD

HP DeskJet 340 portable ink jet printer	268.64
HP DeskJet 882C	299.00
HP LaserJet 6950C	399.00
HP LaserJet 4050N	1397.89
HP LaserJet 8000DN	2979.79

DIGITAL IMAGING

AGFA

ePhoto CL30 digital camera	394.94
ePhoto CL50 digital camera	799.00

CDW® DIRECTORY

PC sales	800-800-4239
Mac sales	800-509-4239
Corporate sales	800-280-4239
Corporate software sales	800-294-4239
Government and Education sales	800-606-4239
Networking sales	800-377-4239

CDW® TELEPHONE HOURS

Sales

Monday-Friday 7 a.m.-9 p.m. CT
Saturday 9 a.m.-5 p.m. CT
Tech Support>Returns for Customers
800-383-4239
Monday-Friday 7 a.m.-9 p.m. CT
Saturday 9 a.m.-5 p.m. CT

EPSON

PhotoPC 750Z digital camera	699.00
-----------------------------	--------

KODAK

DC210 Plus Digital Camera	499.00
DC220 Zoom Camera	599.00
DC260 Zoom Camera	899.00
DC200 Plus Digital Camera	399.00
DC240 Zoom Digital Camera	599.00
DC265 Zoom Digital Camera	899.00

NIKON

Coolpix 700 digital camera	548.97
Coolpix 950 digital camera	948.89

OLYMPUS

Olympus C2000 Zoom digital camera	995.95
Olympus D-340R digital camera	399.95

SONY

Sony Mavica FD73 digital camera	499.00
Sony Mavica FD83 digital camera	699.00
Sony Mavica FD88 digital camera	899.00

UPS SYSTEMS

APC

Back-UPS 200	89.29
Back-UPS 500	149.99
Smart-UPS 700NET	329.00
Smart-UPS 1000NET	485.76
Smart-UPS 1400NET	619.15
SurgeArrest P7 Home	12.56
SurgeArrest Personal	24.53
SurgeArrest Pro	29.20
SurgeArrest Network	31.32

Know your options

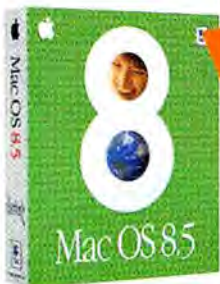

Purchase Mac OS 8.5 today and qualify to download the latest updates. Call your CDW account manager for details.

Apple Mac OS 8.5

\$88.92
CDW 134030



Mitsubishi
Diamond Pro 900U
19" truly flat screen monitor

\$689.89
CDW 130067

Epson Stylus Color 740i
Color inkjet printer
for Mac
~~\$279.00~~ - 50.00=
\$229.00*

CDW 161209
*After \$50 mail-in manufacturer rebate (offer ends 9/30/99)

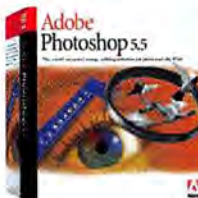

Adobe
Photoshop V5.5
Upgrade

\$187.92
CDW 171265

Global Village Teleport
Internal 56K modem

\$98.57 CDW 148272



Entrega 4-port USB Hub

\$55.74
CDW 133137

Apple
Authorized
Catalog Reseller

All products sold by CDW are third party products and are subject to the warranties and representations of the applicable manufacturers, including but not limited to Y2K compliance. Accordingly, CDW makes no representation or warranty with respect to the Y2K compliance of products sold.

56K modems are capable of 56Kbps downloads, however, current regulations limit download speed to 53Kbps.

Internet connectivity requires access services from an Internet access provider. Contact your local access provider for rates, terms and conditions.

©1999 CDW® Computer Centers, Inc.
200 N. Milwaukee Avenue, Vernon Hills, IL 60061 MW4913B 10/99



Computing Solutions
Built for Business™

www.cdw.com
800-509-4239



Authorized Value Added Reseller

We eat, sleep, and breathe this stuff...



500Mhz G3! Turnkey e-commerce solutions

e-commerce To Go!



The New iBook From Apple Computer™

Call For Pricing

- Includes The Following:**
 SohoStore™ 2.0 e-commerce software
 6 months web site hosting
 Apple PowerMac G3 system
 G3 processor card running at 500Mhz
 *384MB RAM / 32xCD / 10-100BT
 RAGE 128 16MB video card
 6GB boot drive plus 18GB Ultra2 RAID
 Onsite hardware / software support feature
 2 year onsite warranty

0% Business Lease Financing On Apple Systems!

Other configurations available, Just Call!



\$159

Rage Orion In Stock!

ATI Rage 128
16MB Of Video Power!



\$579

DVD-RAM Drive
5.2GB of storage! Watch movies with optional DVD Decoder Card!



\$399

Palm V From 3Com



\$118

Iomega Zip Drive
100MB removable storage USB Interface!



\$174

Panasonic CDR Drive
8x/4x CDR Drive Internal



\$124

ProMax TurboMax Card
Add IDE Drives To ANY PCI PowerMac



\$599

RAILGUN from Bottomline
466Mhz/1MB ZIF



\$399

MacTell Firepower
Firewire ORB Drive



\$159

XLR8 ZIF Carrier Card



Pre-Order Mac OS 9 Today!
\$85.99

Mac OS 9 Coming Soon!



\$659

Agfa T1200 Duoscan
Twin Plate Flatbed Scanner!



\$59.99

Alsoft DiskWarrior
The Must Have Drive Utility



\$209

Yamaha CDRW Drive
4x Record, 4x ReRecord, 16x Read



Professional Level Video Capture
Up to 13.3MB/sec
\$1199



\$239

Epson 850 Printer
Color Inkjet



\$89.99

Interview USB Video Capture Device



\$1199

Viewsonic P815



\$119

128MB PC100 DIMM
For New Blue PowerMac Systems



\$189.99

Time For Ultra2 SCSI
Get Up To 80MB/sec!



\$189

Castelwood ORB
Removable Storage Drive

128MB DIMM PC100

For New Blue G3 Systems Or The Older Beige G3 Systems

256MB...\$399.99
64MB...\$51.99

\$119

Video Capture Card



Aurora Design Fuse

Captures Video At 30fps
60 Fields
Near Broadcast Quality!

\$489

Yamaha CDRW Drive



6416S
6x/4x/16x
internal

External Available:
\$339.99

\$279

12MB Voodoo 2 PCI



Make Your 3dfx Games Go!

Still The Best Game In Town!

\$69.99

- Super CDR/CDRW Deals!**
 Yamaha 6416s 6x/4x/16x.....\$299.99
 External Yamaha 6416s 6x/4x/16x \$359.99
 Panasonic 8x/20x CDR Drive\$294.99
 External Panasonic CDR 8x/20x\$369.99
 Teac CDR58s 8x/24x CDR Drive\$339.99
 External Teac 8x/24x CDR Drive ...\$379.99
 Panasonic 4x/8x CDR Drive\$179.99
- Superior RAM Deals!**
 128MB PC/SD100 168-PIN DIMM ..\$119.99
 64MB PC/SD100 168-PIN DIMM\$51.98
 32MB SD100 168-PIN (Beige G3)\$29.98

- iMac/PowerBook 128MB DIMM\$99.99**
 iMac/PowerBook 64MB DIMM\$59.99
 128MB DIMM 2k Rerfresh\$259.99
 64MB DIMM 2k Rerfresh\$112.99
- Ultra2 80MB/sec SCSI Hard Drives**
 Quantum Atlas IV 10krpm 9.1GB\$479
 Quantum Atlas IV 10krpm 18.2GB\$799
 Quantum Atlas IV 10krpm 36.4GB ...\$1399
 IBM Ultrastar 18ES 18.3GB Ultra2.....\$669
 IBM Ultrastar 18ES 9.1GB Ultra2.....\$359
 Seagate Cheetah 9.1GB 10krpm\$539
 Seagate Cheetah 18.2GB 10krpm\$869

- G3 Daughter Card Upgrades**
 Railgun G3 275/1MB 1.5-1\$249.99
 Railgun G3 366Mhz/1MB 2-1\$489.99
 Railgun G3 400Mhz/1MB 2-1\$599.99
 XLR8 G3 400Mhz/1MB 2-1\$699.99
 PowerLogic G3 400Mhz/1MB 2-1 ...\$669.99
 Newer G3 400Mhz/1MB 2-1\$739.99
- G3 ZIF Card Upgrades:**
 Railgun G3 466Mhz/1MB 2-1\$599.99
 Railgun ZIF Carrier Bundle\$339.99
 XLR8 G3 466Mhz/1MB 2.5-1\$759.99
 Newer G3 466Mhz/1MB 2-1\$799.99

Shipping: \$5, 5 lbs., UPS Ground Payment: No credit card surcharge. Corporate POs welcome. Tax: Texas residents add 8.25% sales tax. Prices: Items, prices and availability subject to change. Returns: Call for RMA number. Must be in original condition, opened software is non-refundable. All orders subject to a minimum 15% restocking fee. Original shipping is non-refundable. Apple brand products are not returnable for credit. Bottom Line Distribution cannot be responsible for errors in typography or photography. Apple specs subject to change. Customer Service: 512-485-4602. International Sales: Bottom Line Distribution is committed to the needs of international Macintosh users. We offer discounted rates with DHL. 2 to 3 day delivery to most countries. Dealer inquiries welcome. Language interpreters available. Address: 715 West 23rd St., Ste. N, Austin, TX 78705. Fax: 512-485-4601. Hours: MF 8-6 CST All Trademarks are the sole property of their respective owners.

Bottom Line Offers Business Leasing on all items we carry (orders over \$1000.00). Call today for details, or fill out a lease form online!

Choose 221 at www.macworld.com/getinfo

Great prices • Excellent service • Free ground shipping on web orders over \$100 & Under 10 lbs.

EASY ONLINE CATALOG **FREE SHIPPING FOR ALL ONLINE ORDERS!** **90 Day Performance Guarantee**

Save Big with iBid!

Make Your Best Bid On ProDirect High Quality Memory!
Any Price, Any Quantity!
We'll do our best to match your price!

Save Make a Bid! Save
APPLE CERTIFIED • HIGHEST QUALITY MEMORY
LIFETIME WARRANTY • 24 HOUR REPLACEMENT
Just Call or Go To
www.pdisales.com/merchant/ibid.html
To Make Your Memory Bid!

Blue Yosemite G3
168 pin SDRAM **Make a Bid!**
32MB • 64MB • 128MB

Beige G3 **Make a Bid!**
168 pin SDRAM
32MB • 64MB • 128MB

iMac 50DIMM **Make a Bid!**
32MB • 64MB • 128MB

7200-9600, 5400-6400 **Make a Bid!**
168 pin 5vDIMM
16MB • 32MB • 64MB

*Due to price volatility in the memory market, while we will do our best to match your price, we reserve the right to reject any bid.

www.pdisales.com/merchant/SCSI.html
ACCELERATOR CARDS

Adaptec ADAPTEC
PowerDomain 2940UW UP TO 40 MB/Sec. \$235
Adaptec AHA2930U PCI to Ultra SCSI HD50 pin. \$99
PowerDomain 3940 UP TO 40 MB/Sec. \$345
PowerDomain 2940U2W Card Only. \$299
Adaptec AHA2906 PCI to SCSI 2 HD50 pin. \$65

ATTO ATTO
Express PCI \$CALL
Dual Channel Express PCI \$389
Express PCI LVD \$329
Express PCI Ultra2LVD Dual Channel \$489

INITIO
Initio Miles UW \$175
Initio Speedway U2W \$299
Initio A100U2W PCI to Ultra 2LVD \$299
UP TO 80 MB/Sec.

TAPE BACKUP
www.pdisales.com/merchant/tape.html
SPEEDY TAPE DRIVES IN STOCK TODAY

Sony DAT

CAPACITY	MODEL	TRANSFER RATE	SALE
8 GB	STD28000	60 MB/Min.	595
24 GB	Sony 9000 DDS3	120 MB/Min.	835
40 GB	Sony 1000 DDS4	120 MB/Min.	1355

DLT Tape Storage

CAPACITY	MODEL	TRANSFER RATE	SALE
40 GB	DLT4000	180 MB/Min.	1979
70 GB	DLT7000	600 MB/Min.	4489
280 GB	DLT47000	180 MB/Min.	5575
980 GB	DLTStor71145T	180 MB/Min.	13899

RETROSPECT 4.0 MAC OR CHEVYNE WINDOWS (NT)
SOFTWARE INCLUDED WITH ALL TAPE DRIVES

DVD, CD/CDR
www.pdisales.com/merchant/dvd.html
www.pdisales.com/merchant/cd.html

Plextor Plexwriter 820 \$499
CD-R Drive Software Included:
Mac-Toast, PC-CD Creator

Panasonic DVD RAM Drive External \$589

Yamaha CRW4416 CDR Drive
2Mb Buffer 4x Recorder, 1x Rewritable, 16x Reader \$339

Toshiba 40x CD Drive XM6401B \$139

For The Best ProDirect CLOSEOUT SPECIALS
Go To
www.pdisales.com/merchant/closeouts.html

HIGH PERFORMANCE SPECIALISTS

For The Best Prices on ProDirect Hard Drives Go To www.pdisales.com/merchant/harddrives.html

Seagate CHEETAH

9.1GB U2W \$525
5.2ms Seek (ST39103LW) External: \$605

18.2GB LP U2W \$865
(ST318203LW) External: \$945
10000 RPM 1024K 5.9MS 5YR LOW PROFILE

36.4GB U2W \$1645
(ST136403LW) External: \$1725
10000 RPM 1024K BUFFER 5.9MS SEEK

Seagate BARRACUDA

9.1GB U2W \$365
(ST39175LW) External: \$445

18.2GB LP U2W \$675
(ST118273LW) External: \$755
7200 RPM 1024K 6.9MS 5YR LOW PROFILE

36.4GB U2W \$1235
(ST136475LW) External: \$1425

50GB U2W \$1299
(ST136475LW) External: \$1375
7200 RPM 512K BUFFER 7.1MS SEEK

IBM ULTRASTAR

4.5GB NARROW/WIDE \$195
(DDR334560S/W) External: \$255

9.1GB NARROW/WIDE \$299
(39130W) External: \$399
7200RPM 512K BUFFER 8.5MS SEEK

18.2GB LP U2W \$665
(DNE5-31850LW) External: \$745
7200 RPM 1024K 6.9MS 5YR LOW PROFILE

36.2GB U2W \$1215
7200RPM 4006K BUFFER 6.8MS SEEK

9.1GB U2W \$515
(39100LW) External: \$595

18.2GB U2W \$855
(318200LW) External: \$935

36.4GB U2W \$1595
(336400LW) External: \$1675
10,000RPM 1024K BUFFER 6.8MS SEEK

DESKSTAR GPX

10.0GB (DTTA-371000) \$179

14.4GB (DTTA-371440) \$199

18.0GB (DTTA-37118) \$269

22.0GB (DTTA-372200) \$349

7200RPM 512K BUFFER 9.5MS SEEK

Quantum
CAPACITY FOR THE EXTREMELY

ATLAS 10K Ultra2 LVD

9.1GB (QM39100TN-LW) \$479 EXT: \$559

18.2GB (QM318200TN-LW) \$829 \$979

36.2GB (QM36400TN-LW) \$1559 \$1539

10000RPM 2048K BUFFER 5.5MS SEEK

ATLAS IV Ultra2 LVD

9.1GB (QM309100KX-LW) \$359 EXT: \$439

18.2GB LP (QM318200KX-LW) \$645 \$725

36.4GB (QM36400KX-LW) \$1199 \$1279

7200RPM 1024K BUFFER 6.9MS SEEK

VIKING II U2W

4.5GB (PX34550LW) \$229 EXT: \$309

9.1GB (PX39100LW) \$319 EXT: \$399

7200RPM 512K BUFFER 7.5MS SEEK

FIREBALL

2.1GB FB32100T-M \$149 INT \$199 EXT

5400Rpm 128k buffer 9.5ms 1 Yr. Warr.

PowerStor Super Deals

USB or Mac SCSI

DESKSTAR GP

13.5GB (DTTA-351350) \$175

16.8GB (DTTA-351680) \$199

20.5GB (DTTA-351203) \$275

25.0GB (DTTA-35125) \$349

5400RPM 512K BUFFER 9.5MS SEEK

Mac IDE Accelerator Power ULTRA33 \$129

- Dual Channel
- Ultra IDE 33 MHz
- Uses Apple Drivers
- Supports 4 Drives
- Great for Internal G3 RAID
- Low Cost Option for Video Editing

Internal Dual Channel PowerRAIDs

20GB	\$925
43GB	\$1195
57GB	\$1375
66GB	\$1675
88GB	\$2095

Includes Ultra 33 MHz Accelerator, All Cables and Brackets, Adaptec Remus Software, IBM GPX 7200 RPM Hard Drive. We pre-configure and Speed-Tune™ for a Plug and Play Solution!

RAID SYSTEMS

Plug in an Ultra 2 PowerRAID™

For Maximum Data Transfer Rates

All PowerRAIDs are Initialized, Speed Tuned, Tested and Bench Marked To insure a True Plug and Save Reliability.

- The Premier Adaptec 2940U2W Ultra2 Wide Accelerator (Available with Dual Channel)
- Raid-Tuned Hard Drives
- Raid Center Enclosures With Maximum Duty Power Supply, Teflon Shielded Cables, High Output Cooling
- Remus Raid Software.
- All PowerRAID components are covered by a 5 year 48 hour replacement warranty.

www.pdisales.com/merchant/MacRaid.html

CHEETAH PowerRAIDs Seagate BARRACUDA PowerRAIDs

18GB PowerRAID SC18 FIXED: \$1895 LEASE FOR: \$76/MO. REMOVABLE: \$2095 LEASE FOR: \$83/MO.	18GB PowerRAID SB18 FIXED: \$1495 LEASE FOR: \$74/MO. REMOVABLE: \$1695 LEASE FOR: \$82/MO.
36GB PowerRAID SC36 FIXED: \$2765 LEASE FOR: \$143/MO. REMOVABLE: \$2965 LEASE FOR: \$152/MO.	36GB PowerRAID SB36 FIXED: \$2295 LEASE FOR: \$108/MO. REMOVABLE: \$2495 LEASE FOR: \$115/MO.
72GB PowerRAID SC72 FIXED: \$4895 LEASE FOR: \$255/MO. REMOVABLE: \$5095 LEASE FOR: \$273/MO.	72GB PowerRAID SB72 FIXED: \$3945 LEASE FOR: \$144/MO. REMOVABLE: \$4145 LEASE FOR: \$154/MO.
144GB PowerRAID SC144 FIXED: \$9595 LEASE FOR: \$339/MO. REMOVABLE: \$9795 LEASE FOR: \$363/MO.	144GB PowerRAID SB144 FIXED: \$7695 LEASE FOR: \$245/MO. REMOVABLE: \$7895 LEASE FOR: \$275/MO.

DIGITAL VIDEO

Adaptec ULTRA HOT CONNECT 8945

www.pdisales.com/merchant/dv.html

PROFESSIONAL QUALITY DIGITAL VIDEO PLUS ULTRA WIDE SCSI PORT

Plug your FireWire equipped Camcorder right into your computer to easily capture digital video and stills. NISX and PAL formats compatible.

Ultra Hot Connect 8945 (WITH FIREWIRE AND ULTRA2 SCSI BOTH ON ONE CARD) \$485

MEDIA 100 QX WITH ADAPTEC PREMIERE 8.0	MAC \$1695
WIN NTS	\$1795
MEDIA 100 QXC WITH ADAPTEC PREMIERE 8.0	\$3795
MEDIA 100 LE WITH DRIVE OR POWERRAID PURCHASE	\$5295

FREE Media 100 Training Video with any Media 100 or PowerRAID purchase at a \$79.95 Value... Only from ProDirect

Pinnacle Mirromotion DC30+ W PREMIERE 4.2 MAC \$865

PowerRAID™ Windows 95/98/NT, Apple MacOS, UNIX

USA Multi-platform

Service & Performance & Price Always™

- 90 Day Performance Guarantee
- Toll-Free Tech Support
- Same Day Shipping
- No Sales Tax Outside MN
- Reseller Pricing Available
- Educ. & Govt. Discounts
- Never a Surcharge!

ProDirect 800-524-9952

10830 Nesbitt Ave. South, Bloomington, MN 55437
Hours: Monday-Friday 8AM-7PM
International Orders: 612-884-0012
ProDirect Fax: 612-941-1109
Toll Free Tech Support: 800-524-9952
Internet: www.pdisales.com
E-mail: info@pdisales.com

Quickly find and order it now on our website!

Global Village Modems



Global Village External 56K V.90 Fax/Modem
\$69.99 after \$30.00 Mail-In Rebate!
 REBATE THRU 9/30/99 (CGV EXT9056K)

Global Village Internal 56K V.90 Modem
 (CGV INT9056K)..... **\$99.99**

Global Village Teleport External USB 56Kflex V.90 Modem (FOR G3 COMPUTERS)
 (CGV EXTUSB56KVP)..... **\$129.99**

Scanners



Agfa SnapScan 1212P Color Scanner
\$99.99 (AGF SNAP1212P)

Agfa USB SnapScan 1212u (Translucent Blue For Mac)
 (AGF SNAP1212UB)..... **\$129.99**

Microtek ScanMaker X6ELDP (36-bit, scans legal)
 (MTK SCANX6ELDP)..... **\$199.99**

Minolta Dimage Scan Dual (For PC/MAC)
 (MIN DIMAGE02AL)..... **\$499.99**

Minolta APS Adapter *For (MIN DIMAGE02AL) & (MIN SCANSPED) Scanners (MIN APSADAPTER)..... **\$149.99**

Networking



Netgear FS104
 Speed Sensing Fast Ethernet Switch
 •Four switched 10/100 Mbps ports •Auto-speed and duplex mode sensing •Each port can run at 10 or 100 Mbps •Built-in LEDs
\$169.99 (NTG FS104)

Asante AsanteTalk
 Ethernet-to-LocalTalk Connection for iMac (allows connection of localtalk printers)
 (ASA 9900S05-01)..... **\$99.99**

Mac Software



Adobe InDesign Upgrade
 •For users of Quark XPress, Adobe Illustrator, PageMaker or Photoshop •Page layout & design for the future of professional publishing •CD for Mac
\$299.99 (ADM INDESIGNUC)

Suitcase™ (8.0) Upgrade
 by Extensis™ (ETM SUITCASEUC)..... **\$34.99**

Eudora Mail Pro (4.2)
 by Qualcomm (QUB EUDORA42UC)..... **\$44.99**

Norton Antivirus (6.0)
 by Symantec™ (SYM ANTV6UC)..... **\$59.99**

QuickBooks Pro (4.0)
 by Intuit (QUB QBK4UC)..... **\$179.99**

Office 98 Macintosh® Edition
 by Microsoft™ (MSA OFFICE98UC)..... **\$399.99**

Final Cut Pro
 by Apple™ (APP FINALEUCF)..... **\$999.99**

J&R COMPUTER WORLD



Walk In
15 Park Row
New York, NY



Phone In
(800) 221-8180



Log In
www.jandr.com
AOL keyword: J&R

Castlewood Drives



Castlewood
 ORB™ 2.2GB SCSI External Drive
 •Compact drive uses pocket-sized removable disks
 •2.2GB capacity •Fast 12Mb/sec. maximum data transfer rate •Mac compatible •Requires ORB™ disks
\$199.99 (CMN ORB25E01)
ORB™ 2.2GB USB External Drive
 (CMN ORB2UE01)..... **\$249.99**
ORB™ 2.2GB Disk •Macintosh formatted
 (CMN ORB27M01)..... **\$29.99 Each**

Epson Printer



EPSON Stylus™ COLOR 740i
 USB Ink Jet Printer for Mac G3s
 •1440 x 720 dpi •USB port (requires USB cable)
 •Blueberry cover matches G3
\$229.99 after \$50 Mail-In Rebate
 (EPS C257111) EXPIRES 9/30/99

LaCie Hard Drive



LaCie External 9GB
 Narrow Ultra SCSI Hard Drive
 •9ms seek time •7200rpm •3-year limited warranty
\$399.99 (LAC 300040)

CD-Writers



QPS Que! Drive
 4x2x8 CD-ReWritable Drive
 •4x write, 2x rewrite, 8x read •USB
\$289.99 (QPS QP4210MAC)

Monitors



Sony Spressa™ CRX100E/X
 External USB CD-RW Drive Kit
 •6x read/4x write / 2x rewrite •USB
\$299.99 (SON CRX100E/X)

Monitors



Panasonic PanaFlat™ LC50S
 15" LCD VIS Flat Panel Color Monitor
 •Active-matrix •USB •For Mac w/adaptor •Speakers
\$849.99 (PAN LC50S)



ViewMate Oz-795G3
 17" Color Monitor w/16.1" VIS
 •Digital on-screen controls •Mates with G3 computer
\$269.99 (VMT 02795G3)

Apple® iBook NEW!

•12.1" TFT screen for pro-quality, super-bright, and super-crisp images •G3 chip offers blazing speed •Built-in CD-ROM drive with tons of bundled software •Long battery life (lasts up to six hours on just one charge) •Built-in 56K modem and high-speed 10/100Mbps Ethernet help you get onto the Internet right away •Surf the net in your home or classroom using AirPort™ wireless networking (optional) •USB port makes it easy to add a printer, mouse, joystick, much more

\$1599.99 (APP M7619LL/A) TANGERINE or (APP M7707LL/A) BLUEBERRY

Available Mid-September!

A J&R EXCLUSIVE!

Includes Apple® 17" Studio Color Monitor!

Apple® Power Macintosh® G3/300

64/6GB/24x-CD A/V Mini Tower with Apple® 17" Studio Color Monitor
 •300MHz PowerPC™ G3 processor •64MB SDRAM •6GB HD •24x CD-ROM •4MB VRAM
 •ATI Xclaim VR with NTSC in/out & Avid Cinema •10/100BASE-T •Apple® 17" Studio Display
\$1799.99 after \$100 Mail-In Rebate!
 (APP M7262LL/A) + (APP M6221LL/A)

Apple® Introduces Blazing New Speeds on the Apple® Power Macintosh® G3 MiniTower Computers!

•350MHz, 64MB RAM, 6GB HD, 32x CD, 1MB L2 Cache	(APP M7556LL/A).....	\$1599.99
•400MHz, 64MB RAM, 6GB HD, DVD, 1MB L2 Cache	(APP M7555LL/A).....	\$1999.99
•400MHz, 128MB RAM, 12GB HD, 32x CD, Zip™, 1MB L2 Cache ...	(APP M7554LL/A).....	\$2499.99
•450MHz, 128MB RAM, 9GB Ultra2 HD, 32x CD, 1MB L2 Cache....	(APP M7553LL/A).....	\$2999.99

Monitors sold separately on these models.

BREAKTHROUGH OFFERS ON BREAKTHROUGH COMPUTERS!

1. Purchase One of the above Apple® Power Macintosh® G3 MiniTower Computers & Receive FREE from Apple®, your choice, via coupon, of one of the following: HP DeskJet 810c Printer or 128MB Memory! **And...**
2. Buy one of the above Apple® Power Macintosh® G3 MiniTower Computers WITH an Apple® 17" Studio Display Color Monitor & Receive a \$100.00 Mail-In Rebate, PLUS your choice of the Hewlett-Packard DeskJet 810c Printer or 128MB Memory! Installation Not Included!

OFFERS GOOD THRU 9/25/99!

Apple® 17" Studio Display Color Monitor

•16" viewable •0.25mm aperture grille pitch •1600 x 1200 pixel max. res. (APP M6221LL/A)..... **\$499.99**

Apple® Macintosh® PowerBook® G3/333

64MB/4GB/24x CD
 •14.1" active-matrix display
 •333MHz PowerPC™ G3 process
 •64MB SDRAM •4GB HD •24x CD-ROM •8MB VRAM •56K V.90 modem •Built-in 10/100BASE-T
\$2499.99 (APP M7304LL/A)

Apple® Macintosh® PowerBook® G3/400

64/6GB/DVD-ROM
 •11" active-matrix display •400MHz PowerPC™ G3 processor •64MB SDRAM •6GB HD •DVD-ROM •8MB VRAM •56K V.90 modem •Built-in 10/100BASE-T
\$3499.99 (APP M7309LL/A)

5-HOUR BATTERY LIFE!

Businesses can lease G3 computers for as little as \$8.88 per month!
For details, call J&R Corporate Sales, (800) 221-3191 or (212) 238-9080

J&R CORPORATE SALES BUSINESS LEASING:

No Money Down, No Payments for 30 Days!
***Call J&R Corporate Sales for details at 1-800-221-3191 or 1-212-238-9080**

To Order Toll Free and Receive a Free Catalogue

800-221-8180

24 Hours, 7 Days, Anywhere In The USA
 PARK ROW • NEW YORK • NY • 10038 FAX: 1-800-232-4432

Not responsible for typographical or pictorial errors. Merchandise is brand-new, factory-fresh & 100% guaranteed! Some quantities may be limited.

Choose 282 at www.macworld.com/getinfo

Order from

www.jandr.com
AOL keyword: J&R

All Major Credit Cards Accepted
Overnight Delivery Available!

Order Code: MW910
 (prices good until 10/15/99)

OUR BEST BUYS ON CD RECORDERS!

EACH CDR DRIVE WILL INCLUDE TOAST MASTERING SOFTWARE, AND 5 FREE DISKS!

	Int.	Ext.
CD RECORDABLE Includes 5 Free Recordable Disks!		
4x12 Plector mechanism, caddy/tray load, 2MB buffer	\$319	\$379
6x24 Teac mechanism, tray load, 2MB buffer	\$359	\$419
8x20 Sanyo mechanism, tray load, 2MB buffer	\$359	\$419
8x20 Plector mechanism, tray load, 4MB buffer	\$479	\$539
8x24 Teac mechanism, tray load, 2MB buffer	\$439	\$495

	Int.	Ext.
CD REWRITABLE Includes 5 Free Rewritable Disks!		
6x4x16 YAMAHA mechanism, tray load, 2MB buffer	\$319	\$379

4x2x20 Plector mechanism, tray load, 2MB buffer	\$359	\$419
6x4x24 Ricoh mechanism, tray load, 2MB buffer	\$359	\$419
8x2x20 Plector mechanism, tray load, 2MB buffer	\$489	\$549
8x2x20 Sanyo mechanism, tray load, 2MB buffer	\$419	\$489

Stomper CD label kit only \$35 with CD-R drive!

HARD DRIVES

Quantum

ULTRA 160/m SCSI New SCSI interface will transfer 160MB/sec on new controllers. Drives will work on older SCSI, Ultra Wide, Ultra-2 controllers.

9.1GB 7200 2MB KN309100LW \$349
 9.1GB 10,000 2MB TN309100LW \$485
 18.2GB 7200 2MB KN318200LW \$639
 18.2GB 10,000 2MB TN318200LW \$805
 36.4GB 7200 2MB KN336400LW \$1199

IDE
 9.1GB 7200 512K KA309100A \$139
 13.6GB 7200 512K KA313600A \$159
 18.2GB 7200 512K KA318200A \$229

We are the #1 source for Quantum hard drives. Check us out at www.megahaus.com/quantum for the best deals around on Quantum.



ULTRA SCSI
 9GB 7200 2MB IBM309170N \$329
 18.2GB 7200 2MB IBM318350N \$639

ULTRA WIDE SCSI
 4.5GB 5400 512K IBM34560W \$195
 9GB 7200 2MB IBM309170W \$335
 18.2GB 1" High 2MB IBM318350W \$645

ULTRA-2 SCSI
 9.1GB 7200 2MB IBM309170U2 \$339
 9.1GB 10,000 4MB IDRV592U4 \$525
 18.2GB 10,000 2MB IDMV518U2 \$859
 18.2GB 10,000 4MB IDRV518XZ \$839
 18.2GB 7200 2MB IBM318350U2 \$649
 36.4GB 7200 4MB IDRH536U2 \$1139
 36.4GB 10,000 2MB IDMV536U2 \$1569

IDE
 9.1GB 7200 512K IBM9GXPC \$159
 10.1GB 7200 512K IBM10GXPC \$169
 14.4GB 7200 512K IBM14GXPC \$189
 15.2GB 5400 512K IBM15GXP \$189
 18.0GB 7200 2MB IBM18GXPC \$259
 20.3GB 5400 2MB IBM20GXP \$255
 22.0GB 7200 2MB IBM22GXPC \$325
 25.0GB 5400 2MB IBM25GXP \$325
 27.3GB 7200 2MB IBM27GXPC \$445
 37.5GB 5400 512K IBM37GXP \$545

WESTERN DIGITAL

4.3GB 5400 512K WDAC14300 \$105
 6.4GB 5400 512K WDAC26400 \$115
 8.4GB 5400 512K WDAC28400 \$125
 9.1GB 7200 2MB WDAC29100 \$175
 10.2GB 5400 512K WDAC31020 \$155
 13.0GB 5400 512K WDAC31300 \$175
 18.0GB 7200 2MB WDAC41800 \$275
 20.0GB 5400 2MB WDAC42040 \$275

Be Y2K ready! Check out megahaus.com for the latest products to protect your valuable data!

HARD DRIVES

Seagate

ULTRA SCSI
 4.5GB 7200 512K ST34520N \$189
 4.5GB 7200 512K ST34573N \$325
 9.1GB 7200 512K ST39140N \$315
 9.1GB 7200 1MB ST39173N \$375
 18.2GB 7200 1MB ST118273N \$679

ULTRA WIDE SCSI
 4.5GB 7200 512K ST34520W \$189
 4.5GB 7200 512K ST34573W \$325
 9.1GB 7200 512K ST39140W \$315
 9.1GB 7200 1MB ST39173W \$375
 18.2GB 7200 1MB ST118273W \$679

ULTRA-2 SCSI
 9.1GB 10,000 1MB ST39103LW \$539
 9.1GB 10,000 4MB ST39103LW4 \$575
 9.1GB 7200 1MB ST39175LW \$359
 18.2GB 7200 1MB ST318275LW \$689
 18.2GB 10,000 1MB ST318203LW \$925
 18.2GB 10,000 4MB ST318203LW4 \$925
 36.4GB 7200 1MB ST136475LW \$1199
 36.4GB 10,000 1MB ST136403LW \$1599
 50.1GB 7200 1MB ST150176LW \$1299

IDE
 4.3GB 5400 256K ST34311A \$85
 4.3GB 5400 512K ST34312A \$89
 6.4GB 5400 256K ST36421A \$115
 6.4GB 5400 512K ST36422A \$119
 8.6GB 5400 512K ST38422A \$119
 10.2GB 5400 512K ST310232A \$139
 13.6GB 5400 512K ST3136032A \$149
 17.2GB 5400 512K ST317424A \$179

Maxtor

8.4GB 5400 512K M90845D \$125
 10.0GB 7200 512K M91024D \$160
 13.0GB 5400 512K M911303D \$155
 17.2GB 5400 512K M91728D \$195
 20.4GB 7200 512K M92048D \$285

IDE Ultra ATA/66
 13.6GB 5400 2MB M91360U \$165
 20.4GB 5400 2MB M92040U \$255
 27.2GB 5400 2MB M92720U \$325

2.5" IDE LAPTOP

3.2GB 8.45mm Toshiba MK3212MAT \$125
 4.3GB 8.45mm Toshiba MK4309MAT \$165
 6.4GB 8.45mm Toshiba MK6412MAT \$195
 10GB 12.5mm Toshiba MK10111AV \$325
 6.4GB 9.5mm IBM DB206480 \$229
 8.1GB 12.5mm IBM DC208100 \$329
 10GB 12.5mm IBM DC210000 \$355
 14.1GB 17mm IBM DC214000 \$535

We are committed to being the #1 Source for hard drives for Macs. If you need a drive or drive accessory not listed here, we probably have it. Call for pricing and availability.

Nobody beats our deals.
 Nobody has more drives.

USB PRODUCTS

100MB Zip (ZIP100USB) \$145
 USB to SCSI adapter (USBSCSI) \$89
 SuperDisk drive, 120MB & floppy (USBL120) \$149
 Floppy Drive (USBFLOPPY) \$99
 8GB Hard Drive (USB8GB) \$219
 12GB Hard Drive (USB12GB) \$299
 16GB Hard Drive (USB16GB) \$369
 USB Case for IDE hard drive (USBCASE) \$99
 Call about new USB CD Rewritable!

G3 UPGRADES

Upgrades for the new G3 Mini Tower Macintosh computers.
 Adaptec PCI SCSI card (A2905E) \$65
 20GB Hard Drive (M92048) \$285

We are the #1 Source in the US for multidrive towers. Call us with your specifications & we can build a customer tower for your G3. Need a 15 drive tower with CDs, CDRs, CDR-Ws, Tape drives, and hard drives? NO PROBLEM at MegaHaus!

HOT SELLERS

YAMAHA

Drive with Toast, Direct CD, 1 Free CD-RW disk

6x4x16 CD-RW Drive

Internal (YCRW6416M) \$279
 External (YCRW6416MX) \$339

DVD RAM
 Toshiba SCSI DVD RAM drive (SDW1101) \$439
 Panasonic SCSI DVD RAM drive (LFD101U) \$555
 Mac DVD RAM driver software (DVDSTFMAC) \$59
 DVD RAM media (DVDDRAMDISK) \$35

Fargo InkJet CD Color Printer (CDPRINTER) \$999
 Adaptec Ultra Wide PCI controller (A2940MUW) \$285
 Adaptec Ultra-2 PCI controller (A2940MU2) \$385
 Toshiba SCSI 5X DVD ROM (SDM1201) \$149

RAID

We can custom configure a RAID system to your exact needs. Call one of our RAID experts at 800-766-5653. Here are a few of our popular RAID components.

Enclosure holds 3 Hot Swappable SCA drives
 \$279 (SCA3DR-LVD) INTERNAL
 ADD \$100 FOR EXTERNAL

CD ROM

SCSI

Plector PX32TS (tray) 32X 85ms \$109
 Plector PX32CS (caddy) 32X 85ms \$139
 NEC CDR3010 40X 85ms \$85
 Toshiba XM6401B 40X 79ms \$83
 Plector PX40TS 40X 85ms \$109

WIDE SCSI

Plector PX40TSUW 40X 85ms \$159

IDE

NEC CDR3000 40X 75ms \$59
 Toshiba XM6602B 40X 79ms \$57
 Mitsumi CRMCFX40X 40X 80ms \$59
 Memorex CD48X 48X 90ms \$65
 Kenwood UCR412 52X 90ms \$109
 Memorex CD56X 56X 90ms \$79

CD CHANGER
 Pioneer 24X 6 Disc external SCSI DRM6324X \$149
 Custom configurations of multidrive CD Towers are a specialty for us. Call with your needs.

TAPE BACKUP

Capacity Native-Compressed Max. Speed

4mm DAT

2-4GB 66MB/min Seagate STD24000N \$549
 4-8GB 66MB/min Seagate DDS-2 STD28000N \$629
 4-8GB 90MB/min Sony SDT7000AI \$559
 4-8GB 60MB/min HP C1599AI \$719
 6GB 52MB/min Indigita IDT2500 \$479

12-24GB 144MB/min Sony DDS-3 SDT9000AI \$759
 12-24GB 132MB/min Seagate 5TD224000N \$849
 12-24GB 120MB/min HP DDS-3 C1554AI \$929
 20-40GB 288MB/min Sony DDS-4 SDT10000AI \$1129
 32-64GB 90MB/min Sony TSL7000 8 tape load \$1899
 48-96GB 48MB/min Seagate 5TL496000N \$2199
 72-144GB 120MB/min HP C5648A 6 tape load \$2679

EXABYTE 8mm DAT

7-14GB 120MB/min ELIANT820 \$1259
 20-40GB 360MB/min EXB8990 \$2189
 70-140GB 60MB/min EXB110H 10 tape loader \$2699

QUANTUM DLT

20-40GB 180MB/min DLT4000 \$1759
 35-70GB 600MB/min DLT7000 \$4499
 40-80GB 600MB/min DLT8000 \$5299

REMOVABLE MEDIA

Iomega

100MB Zip Ext SCSI \$119
 2GB Jaz Internal SCSI \$300
 2GB Jaz External SCSI \$319
 1GB Jaz disk 2-4/5-9/10+ \$775/573
 2GB Jaz disk 2-4/5-9/10+ \$86/84/82

Maxoptix Magneto Optical
 2.6GB SCSI drive \$1129
 5.2GB SCSI drive \$1509
 Sony Magneto Optical
 5.2GB SCSI drive \$1499

MEDIA

CD RECORDABLE MEDIA
 Nobody Beats MegaHaus for CD media. Large quantities available.

Max Speed	Alone	w/CDR
5 Pack (CDR74B-5)	4x \$19	\$17
20 Pack (CDR74B-20)	4x \$36	\$33
50 Pack (CDR74B-50)	4x \$74	\$70
100 Pack (CDR74B-100)	4x \$135	\$125
5 Pack (CDR74-5)	8x \$21	\$19
20 Pack (CDR74-20)	8x \$42	\$39
50 Pack (CDR74-50)	8x \$93	\$89
100 Pack (CDR74-100)	8x \$159	\$149

CD REWRITABLE MEDIA

5 Pack (CDR74WB-5)	2x \$33	\$29
20 Pack (CDR74WB-20)	2x \$75	\$69
50 Pack (CDR74WB-50)	2x \$155	\$145
100 Pack (CDR74WB-100)	2x \$269	\$259
5 Pack (CDR74W-5)	4x \$59	\$55
20 Pack (CDR74W-20)	4x \$149	\$145
50 Pack (CDR74W-50)	4x \$359	\$349
100 Pack (CDR74W-100)	4x \$689	\$679

CD-R PRINTABLE SURFACE

5 Pack (CDR74PB-5)	4x \$24	\$21
20 Pack (CDR74PB-20)	4x \$55	\$52
50 Pack (CDR74PB-50)	4x \$109	\$99
100 Pack (CDR74PB-100)	4x \$179	\$169
5 Pack (CDR74P-5)	8x \$27	\$24
20 Pack (CDR74P-20)	8x \$65	\$62
50 Pack (CDR74P-50)	8x \$139	\$135
100 Pack (CDR74P-100)	8x \$239	\$229

CD RECORDABLE PLATINUM MEDIA

5 Pack (CDR74PA-5)	8x \$23	\$21
20 Pack (CDR74PA-20)	8x \$45	\$42
50 Pack (CDR74PA-50)	8x \$102	\$97
100 Pack (CDR74PA-100)	8x \$169	\$159

TEJUN OPTICAL MEDIA - Lifetime Warranty

Size & Description	2-4	5-9	10+
128MB,3.5", 512K	\$13	\$9	\$7
230MB,3.5", 512K	\$14	\$10	\$8
640MB,3.5", 2048K	\$19	\$17	\$15
1.3GiB, 5.25", 1024K	\$26	\$22	\$24
2.3GiB, 5.25", 512K	\$30	\$26	\$24
2.6GiB, 5.25", 1024K	\$33	\$29	\$27
5.2GiB, 5.25", 2048K	\$70	\$68	\$64

BACKUP TAPES

4mm DAT 90M 3 pack w/enc \$20 Limited Qty #DA19903	
4mm DAT 120M	\$13 \$10 \$8
4mm DAT 125M	\$26 \$23 \$21
4mm DAT 150M	\$59 \$57 \$55
8mm DAT 112M 2 pack \$10 Limited Qty #DAT03011202	
8mm DAT 160M	\$17 \$14 \$12
TR4	\$29 \$26 \$24
TR5	\$47 \$44 \$41

DLT MEDIA SALE

DLTIII 10-20GB	\$38 \$35 \$34 \$31
DLTIII 15-30GB	\$40.5 \$38 \$36 \$34
DLTIV 20-40GB	\$74 \$70 \$68 \$66

Since
 The Drive Authority
 1987

1-800-786-1184

Sales lines open: M-F 8-8 Sat 9-3 CST

www.megahaus.com

Secure ordering • Daily Specials • #1 Drive Store on the Web!



2201 Pine Drive, Dickinson, Texas 77539
 (281)534-3919 FAX (281)534-6580

Prices & specifications subject to change without notice. Shipping charges are nonrefundable. Returns must be in new condition and in original packaging. Defective items may not be returnable. No refunds on software or special orders (items not listed in ad). All refunds subject to 15% restocking fee. All trademarks are registered trademarks of their respective companies. Personal checks hold for clearance. We reserve the right to refuse any sale for any reason. Bundle price good only if sold at price. All warranties listed are manufacturer's warranty only. ©1999 MegaHaus Inc.

PRODUCT INDEX

Category	Page No.	Category	Page No.
Business Operations144-145	Peripheral Products160-164
Bar Code		Cables	
Inventory Management		CD Rom	
		Digital Media	
Communications/		Magnetic Media	
Networking145	Printing Supplies	
Cross Platform		Services164-166
Education/		Data Recovery	
Entertainment146-147	Digital Production	
Discount Software		Printing	
		Repair	
ISP145	Systems & Peripherals152-160
Web Hosting		USB148-149
Graphics146	Account Manager:	
		Carol Johnstone.....415.243.3691	
Memory & Upgrades160-164	carol_johnstone@macworld.com	
		Account Manager:	
Digital Advertising Coordinator:		Niki Stranz.....415.243.3664	
Russ Nordmeyer415.243.3511		niki_stranz@macworld.com	
production@macworld.com		Assistant:	
		Alissa Mach.....415.243.3628	
		alissa_mach@macworld.com	

Call Us Toll Free 800-345-4220

Broadest Selection of Bar Code Products in the Industry

- Technically superior products direct from the manufacturer
- Toll free technical and pre-sale support
- 24-hour turnaround on repairs
- Free UPS Blue shipping in U.S.
- 30-day money back guarantee
- Portable & non-portable Batch Readers
- Cordless interactive R/F Terminals
- Wand, Laser, CCD, Magstripe or Slot Badge
- PostScript bar code fonts



or visit our website at
www.BARCODEHQ.COM
for a complete catalog and bar code primer

WORTHINGTON
DATA SOLUTIONS

Phone: 831-458-9938 • Fax: 831-458-9964



POINT OF SALE • INVENTORY CONTROL

Software & Hardware for:



Now iMac compatible

- Retail/Wholesale
- Mail Order
- Internet Commerce
- Rentals
- Service/Repair
- Manufacturing
- FileMaker Tools

- Fully Integrated Accounting
- Multi-Site Polling • Cross Platform
- Barcode Readers • Receipt Printers
- Cash Drawers • Mag Stripe
- Ribbons/Paper/Labels
- Credit Card Authorization
- & Deposit Software

www.posdirect.com

(800) 622-7670 • sales@posdirect.com
(618) 985-8237 vox • (618) 985-3014 fax



Order Free
CD Rom on
Web Site

Choose 466 at www.macworld.com/getinfo

BAR CODE SOLUTIONS

- Labeling Applications
- Bar Code Font Packages
- Inventory Management
- Time & Attendance
- Scanners & Lasers
- Thermal Label Printers

Visit us online at:
www.bearrock.com

Bear Rock Offers:
Free Expert Consultation,
Lifetime Technical Support
and Satisfaction Guaranteed
on ALL Bar Coding products!

Bear Rock Welcomes VARs.



FREE Handbook
"Bar Code Basics"
A User's Guide to Bar Coding

Call Today for a FREE Consultation!

800 232-7625

Intl: (530) 672-0244 Fax: (530) 672-1103

Choose 402 at www.macworld.com/getinfo

Create your own bar code graphics.



Imaging
-Imaging Magazine

CALL FOR FREE DEMO

Bar Code Pro v3.5 with Veribar

For guaranteed readability!

SNX

www.snx.com

Call 800 619-0299



Tel 718 499-6293

Fax 718 768-3997

Create perfect PostScript (EPS) bar code graphics for Quark, PageMaker, Illustrator, Freehand, etc. All popular bar code types (UPC, Postnet, 39, EAN, 128, ITF, ISBN) included. Works with any printer resolution, with no fonts required! Mac/Win95/NT

Choose 401 at www.macworld.com/getinfo

FREE DEBT RELIEF!

Lower your monthly payments and lower the interest you pay - INSTANTLY!
Fast - Private - FREE

This is not a loan. This is not bankruptcy. This is a way out of Debt - and it's Free!

Call Us Today!
We CAN help you...
and it's FREE.

AMERIX CORPORATION
1-800-570-3021
(code 4276)



Mouse Pads

Great Desk Advertising
Custom Printed
Manufacturer Direct

MicroStore™ Inc.
P.O. Box 125 • Le Sueur, MN 56058
800-962-8885 Fax: 507-665-2604
www.microstore-mousepads.com
Choose 405 at www.macworld.com/getinfo

Think Windows.
Think Macs.
Think network.
Think nightmare.
Think again.

PC MACLAN* A.K.A. & PC MIGRATOR

Connect. Rename. Migrate.

The complete solution for all of your Mac OS-to-Windows connectivity needs.

* Now includes MacOpener, the leading solution to open, read and write Mac media on a PC.

1-877-462-2272
www.miramarsys.com/products/olorder.htm



Shop our

exciting

USB

section

see pages

148-149!

Digging for ideas?



Get
FIRST MONTH FREE!
(promo code: macw-3489)

Bring your IDEAS to Life yourname.com

Fully loaded web site for \$20 /month*

- 50 MB disk space
- 2 GB traffic / month
- 10 mailboxes
- Frontpage™ server extensions
- web based control panel, web site statistics, etc.

NEW! Speciality Packages:

Media Site: featuring RealAudio®, RealVideo®, Flash™, Truespeech

Web Stores: One Stop Solutions for web store hosting, shopping carts, secure servers, credit card processing.

30 day money back guarantee!
24x7 toll-free tech support

For more details visit our web page or call toll free.

 **NetNation** Communications Inc. www.netnation.com
1-888-277-0000
Int.: +1(604) 688-8946

Set up fees not included. Prices and features subject to change without notice. All trademarks are the property of the respective owners.

StickerPIX™
The Mini Photo Sticker Studio

Over 200 Frames!

**FOR FUN!
FOR BUSINESS!**

\$39.99

WWW.XLSOFT.COM

Choose 407 at www.macworld.com/getinfo

Up to 80% OFF SOFTWARE
For Students, Teachers, & Schools!

\$99

Bryce 4.0 \$149
CodeWarrior Pro 5.0 \$119
Dreamweaver 2.0 \$99
Electric Image
Broadcast 2.9 \$729
FileMaker Pro 4.1 \$119
Final Draft 5.0 \$149
FLIGHTCHECK3.5.2 \$199
Poser 4.0 \$169

Software Outlet **FREE Catalog!**
(800) 568-6837

(732) 223-8770 Fax# (732) 223-8768
Email macuser@www.swoutlet.com
www.swoutlet.com

CADMOVER® v.5.1 What good is a built in translator if it doesn't work?

You've worked hard and now it's time to use those files in another program. You try to import them & all you get is garbage. Not with CADMOVER - For over ten years we've been helping people beat their deadlines, no re-drawing, no touch-ups.

File formats: DWG, DXF, EPSF, PICT, CGM, IGES, HPGL, STL, MiniCAD, DDES2, etc... Internal Features: scaling, 2D/3D views, font mapping and more. With 16 decimal place accuracy redrawing is a thing of the past.

KANDU
software corporation

800-579-2244 • <http://www.kandusoftware.com/macworld>

Choose 408 at www.macworld.com/getinfo

999software.com **\$9.99**

ALL software

- RIVEN
- JOURNEYMAN PROJECT III
- TITANIC
- MASTERCOOK DELUXE
- CAESAR II
- IMPERIALISM
- KINGS QUEST 7
- QUANTUM GATE
- FLIPPER
- YOU DON'T KNOW JACK I, II, SPORTS, MOVIES
- BEATLES HARD DAYS NIGHT
- P.A.W.S.
- CATZ
- STAR WARPED
- CREATURES
- CARMEN SAN DIEGO
- JUMP START
- FATTY BEAR'S BIRTHDAY SUPRISE
- KID PIX STUDIO
- DR. SEUSS GREEN EGGS & HAM, ABC'S, CAT IN THE HAT
- ISAAC ASIMOV ABOUT SPACE
- A.D.A.M. THE INSIDE STORY
- SCHOOLHOUSE ROCK 1ST-4TH GRADE MATH

over 500 titles on our web site
800-818-5217 www.999software.com

ACADEMIC DISCOUNTS

Back to School Savings for Students and Teachers!

BBEdit	\$65	ElectricImage	\$619	Lightwave 3D	\$29
Boris Effects	\$399	Filemaker Pro	\$109	Minicad 8	\$329
Bryce 4	\$139	Fireworks 2	\$98	Microsoft Office 98	Call!
Coda Finale 98	\$199	Flash 4	\$98	NisusWriter	\$69
CodeWarrior Pro 5	\$109	Form•Z	\$849	Painter 5.5 Web	\$199
Director 7	\$329	Freehand 8	\$98	Scriptware	\$129
DreamWeaver 2	\$98	Infini-D	\$269	Strata StudioPro	\$439

Check out more products and prices on-line, 'cause this ad is too small! Call for Free Catalog!

1-800-333-8571
Fax PO's and ID's to 512-450-0263
www.ADWonline.com

Choose 410 at www.macworld.com/getinfo

STUDENTS!

Save up to 75% OFF popular software!

THOUSANDS OF TITLES AVAILABLE!
FREE CATALOG!

1-800-874-9001

JourneyEd COM

JOURNEY EDUCATION MARKETING

Choose 409 at www.macworld.com/getinfo

"THANKS TO THE MACWORLD SHOPPER SECTION OUR COMPANY HAS GROWN OVER 400% IN THE FEW SHORT MONTHS WE'VE ADVERTISED. AS A RESELLER OF HIGH-END QUALITY ERGONOMIC CHAIRS, I DEPEND ON MACWORLD TO HELP PUT ME IN TOUCH WITH EVERYONE FROM BANKERS TO MUSICIANS."

Jim McGaw
Owner

www.sittingmachine.com

"AS A LEADING DEVELOPER OF PC-TO-MAC CONNECTIVITY SOFTWARE, MIRAMAR SYSTEMS RELIES ON REACHING A CAPTIVE READERSHIP OF MAC OS-BASED BUYERS AND DECISION MAKERS. MACWORLD MAGAZINE'S SHOPPER SECTION HAS CONSISTENTLY OUT-PERFORMED OTHER MAC PUBLICATIONS THAT WE'VE ADVERTISED IN WITH HIGHER RECALL AND QUALITY LEADS. A LOT OF MAGAZINES TALK ABOUT THEIR 'VALUE ADD', BUT MACWORLD MAGAZINE TRULY DELIVERS."

Renee Cooper,
Director of Marketing,
Miramar Systems, Inc.

www.miramarsys.com

"MACWORLD CONSISTENTLY PRODUCES INQUIRIES AND RESULTS! NEW & REPEAT CUSTOMERS ALL SAY: 'I SAW YOUR AD IN THE MACWORLD SHOPPER.'"

KEEP UP THE GOOD WORK!"

DAVID ASH
OWNER
MacSOLUTIONS

WWW.MACSOLUTIONS.COM

SAVINGS FOR STUDENTS, TEACHERS, & SCHOOLS

ACADEMIC DISCOUNT SUPERSTORE / UP TO 80% OFF

After Dark 4.0 Deluxe.....	\$45
Authorware 4.0.....	\$399
Auto F/X AutoEYE.....	\$75
Auto F/X Photo/Graphic Edges	\$119
Boris FX 4.0 for Premiere.....	\$479
Bryce 4.0.....	\$159
CADtools 2.0.....	\$159
Cakewalk Metro 4.0.....	\$139
Canoma 1.0.....	\$399
Canvas 6.0.....	\$199
CheckUp 1.5.....	\$145
Coda Finale 98.....	\$249
Conflict Catcher 8.....	\$75
CorelDRAW 8.0.....	CALL
Cubase VST 4.0.....	\$199
DeBabelizer 3.0.....	\$275
DenebaCAD 1.5.....	\$269
Director 7.0.....	\$349
Dramatica Pro 3.0.....	\$209
EdgeWizard 2.0.....	\$75
ElectricImage 3D 2.9.....	\$739
Electrifier Pro.....	\$245
EndNote 3.0.....	\$105
FireWorks 2.0.....	\$739
Font Agent 2.7.....	\$59
Font Reserve 2.0.....	\$89
Form Z 3.0.....	\$899
FreeHand 8.0.....	\$99
Gemini PlugIn.....	\$99
Headline Studio 1.0.....	\$149
HomePage 3.0.....	\$59
InfinID 4.5.....	\$299
IntelliHance 4.0 Pro.....	\$99
MAPublisher 3.5.....	\$125
MacDraft 4.3.....	\$145
MacDrive 98.....	\$39
MacLinkPlus 10.1 Deluxe.....	\$69
MagicMask 2.0.....	\$75
Mathematica 3.0.....	\$139
MiniCAD 8.01 Vectorworks.....	\$339
Mirage NY Scenery & Skylines	\$99
Myrmidon 2.1.....	\$39
Neal's Efex.....	\$49
NetObjects Fusion 3.0.....	\$99
NewTek Inspire 3D.....	\$299
Nisus Writer 5.1.3.....	\$79
Painter 5.5.....	\$219
Pantone ColorSuite.....	\$229
PhotoSpray.....	\$69
PhotoTools 3.0.....	\$79
Portfolio 4.0.....	\$109
Poser 4.0.....	\$195
PowerCad 4.0.....	\$399
RayDream Studio 5.5.....	\$119
SciFi Textures.....	\$125
ScriptThing 3.0.....	\$149
Scriptware 1.0.....	\$139
Strata StudioPro 2.5.....	\$449
Total Xaos.....	\$119
Virtual PC 3.0.....	\$159
Wacom Intuos 9x12 Tablet....	\$399
WebPainter 3.0.....	\$55
WebSTAR 3.0.....	\$479
WebSpice 2,000,000.....	\$59
WordPerfect 3.5.1.....	Call
FLIGHTCHECK 3.52.....	\$199

NEW

FREE CATALOG 800-699-1836



Dreamweaver 2.0

Professional Web Site Design and Production

\$99



3D Suite 3.0

Includes:
Bryce 3D
Poser 3
Painter 3D
Ray Dream Studio 5.0

\$299

FileMaker Pro 4.1

Powerful relational database software

\$139



EyeCandy 3.01

Photoshop filters that take the drudgery out of creativity.

\$79



Wacom Intuos 6x8

Intelligent graphics tablet system

\$285



Flash 4.0

Web Standard for Vector Graphics

\$99

LightWave 3D 6.0

*Model
*Animate
*Render

\$889



CodeWarrior Pro R5

Integrated Development Environment

\$119



Mask Pro 2.0

Professional precision masking and selection tool

\$149



Poser 4.0

3D Figure Design Tool

\$194

NY Scenery & Skylines

100 Royalty-Free photographic images
-35 mb compressed
-CMYK JPEG's

\$99



Final Draft 5.0

Professional Screenwriting Software

\$149



Visit our website for...

K-12 software -Books -Videos -Free software contests -Secure ordering -and more...



Software ShowCase (800) 699-1836

417 Euclid Ave, Loch Arbour, NJ 07711
Phone# 732-660-8820 Fax# 732-660-8828



* Not responsible for typographical errors
* Prices subject to change

WWW.SOFTWARESHOWCASE.COM

macally™

Call us for dealers near you 1-800-644-1132
www.macally.com



USB Peripherals for Mac

NEW

macally
isweet®

Supports Keyboard boot-up

macally
ihub7®

Macally is proud to bring you the latest USB peripherals for Mac users. iMousepro, iMouse, iBall, iStick, iHub, iHub7, iKey and iSweet are specifically designed to pair with your Mac. Improve your productivity with Macally USB peripherals.

All trademark or registered trademarks are the property of their respective owners.

Choose 413 at www.macworld.com/getinfo

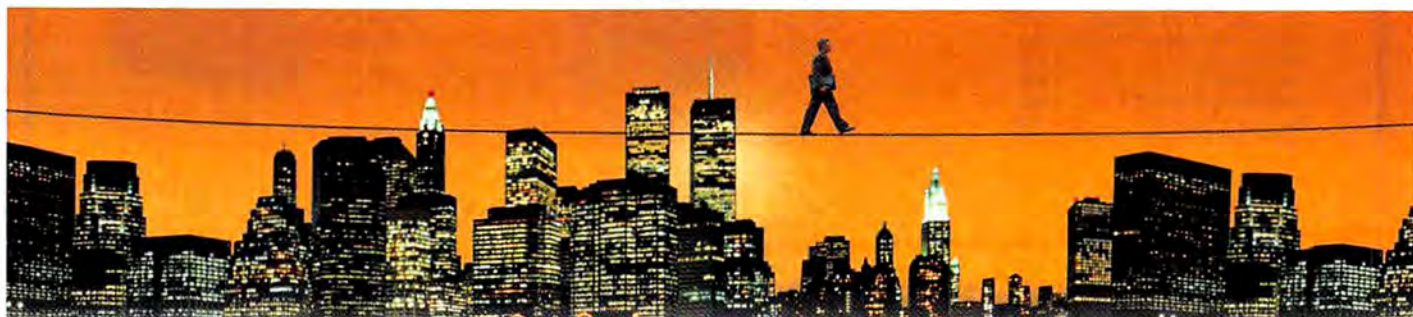

This is no time to worry about being properly connected.

Universal Serial Bus technology.

It's connecting everything to everything in the computer world - faster, easier and limitless. USB makes it simple to connect virtually everything - serial devices, parallel printers, networks and storage devices - as many as you need, quickly and efficiently. USB is truly a "universal" solution for home, office, and corporate computing environments.



Belkin Components
www.belkin.com
310.898.1100 • Fax 310.898.1111
Los Angeles, CA • United Kingdom • Holland • Atlanta, GA



Belkin has been part of this revolution from the beginning, and we're particularly proud of our USB line - the finest and most balanced in the industry. From our ExpressBus™ hubs to our USB BusPort™ for Macintosh, we've got everything you need to take full advantage of the USB revolution. New products such as our USB Serial Adapter for Mac's, USB to SCSI Adapter and USB VideoBus™ maximize the performance capabilities of USB.

Belkin USB products make advanced connectivity a pleasant stroll.

© 1999 Belkin Components. All rights reserved. All trade names are registered trademarks of respective manufacturers listed. 99AD080

The Best Selling USB Serial Adapter is Now Even Better!



Compatible with more Apple printers!
Prints up to 4 times faster!

USB Twin Serial Adapter

Add 2 Mac serial ports to your iMac or "Blue" G3 (\$79)
• For use with tablets, modems, cameras and many printers
• Get two ports for the price of the single port solutions!

USB PDA Adapter

Connect Palm organizers to your iMac, "Blue" G3 or Win98 PC (\$39)

NEW USB 4-Port Hub

Connect more USB devices to your iMac or "Blue" G3 (\$49)

KeySpan USB Card

Add 2 USB ports to your PCI PowerMac (\$39)

SX Pro Serial Card

Add 4 serial ports to your PCI PowerMac (\$179)

www.keyspan.com (510) 222-0131



Choose 415 at www.macworld.com/getinfo



iThink therefore iConnect™

1-800-326-5294



iSCSI USB-to-SCSI Cable
Use your existing SCSI devices with your iMac

iSerial USB-to-Serial Converter
Comes in 2 and 4-port models.

PCI to USB Card
Install into your desktop PC and connect USB peripherals.

iConnect 008, USB-to-Parallel Cable
For your old printers and other parallel devices.

4 and 7 Port Hubs
Connect additional USB devices...Ideal for keyboard, mouse, joystick, etc.

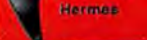

PCI to USB Card



iConnect 008



Hubs



iSerial



iSCSI

iSee Digital Camera
Ideal for teleconferencing, web sites, motion & still image capture & security monitoring.

iRiS 5-Lens KB (3.6mm to 8mm lenses)
Match your iSee camera to any iMac color.

iView USB Capture Device
Portable motion picture and still image capture at your fingertips.

iRead USB Flash Card Reader / Writer
For Type II, Compact Flash & SmartMedia.

Hermes USB Gamepad
Rated #1 for USB gaming, compatible with Virtual Game Station from Connectix.

Podiki 2-button USB mouse
World's first for the Mac.

Ares USB Joystick
Winner Editor's Choice Award gibbed.com.

www.ariston.com

Choose 416 at www.macworld.com/getinfo

Introducing 4 new members of the iPeripherals family of products

iDock II

Add a floppy drive, an ADB, two Serial, four USB ports, and a swivel base to your iMac!

mini-Geo

Add two Apple serial Geo ports to your new Mac's with our new USB-Serial adapter!

mini-ADB

Add two switchable ADB ports to your iMac with our new USB-ADB adapter!

gDock

Add two Serial and four USB ports to your new G3! Comes with built-in converter for a future Zip™ or Super Disk Drive.

www.compuable.com

800.344.6921

CompuCable

info@compuable.com

CompuCable Mfg. Group
210A McCormick Avenue • Costa Mesa, CA 92626



Choose 467 at www.macworld.com/getinfo

CD COPIER

NEW!

Fast **32X**
Records Music.
Easy to Use.



\$999

PRINCETON DIS from **800-426-0247**
www.princetondisc.com

An Art Department's Best Friend

You Always Want It Back or Know Who It Belongs To.



Custom Imprinted Zip®, Jaz®, CD's for the same price you're paying now!

24 Hour Turnaround
No Minimums
All Related Accessories And More!

MYMARK ENTERPRISES
Custom Imprinted Media Storage & Accessories

1 877-2MYMARK

Choose 418 at www.macworld.com/getinfo

CD R 8x Media:

Mitsui spindle...\$1.27
Mitsui jewel case...\$1.47
Taiyo Yuden spindle...\$1.27
Mitsui printable spindle...1.67
Taiyo Yuden printable spindle...\$1.67
Ritek 80 min spindle...\$1.59

ALL PRICES BASED ON 100 PIECES
CD-RW...CALL
CD-R Silk Screening Available.

CD-RECORDER BUNDLES

Plextor \$499 Also Yamaha, Teac and Panasonic
Rimage Printer Bndl...\$3,199

CD-R BLENDS

89¢

SHIMAD

AFEX CD Color Printer 1440 dpi...\$1,399
CD LabelMaker...\$29

1-888-4-SHIMAD toll free 888-474-4623
PH. 650-493-1234 FAX: 650-493-1333

DUPLICATORS:

Replica MediaFORM SA1000 1CD-R CD5900 w/ 8CD Recorder...\$5,299
\$949
CD3704 Autoloader w/ 4 CD Recorder...\$7,199
CD3706P Autoloader w/ 6 CD Recorder Printer...\$15,999

FOR CD DUPLICATION...CALL

8x CD-R

PLEXWRITER 8/20

\$459
External \$499



All drives include Toast 3.5.6 & Direct CD, Cables, 8x compatible media & Toll Free Support

Get a free CD Stomper with the purchase of your Plextor 8x drive. The CD Stomper comes complete with applicator, labels, inlay cards and templates for all your favorite publishing programs.

Free CD Labeling Kit



BLANK CD-R MEDIA

Mitsui Bulk 100 pack 100 @ \$1.39
Mitsui Digital Audio 100 @ \$3.39
Mitsui Branded 100 pack 100 @ \$1.39
Generic 74 CD-R 100 @ .89



TDK SONY



Printing & Duplication Services

- 24 hour turnaround
- 4 color printing
- Great Pricing!

www.mediasupply.com
800-944-4237

MEDIA SUPPLY

All packages ship by Federal Express
410 Eagleview Blvd.-Exton PA 19341-Fax: 610-458-9464

Choose 419 at www.macworld.com/getinfo

YOUR ONE-STOP CD-R SUPERSOURCE!

CD-R DUPLICATORS

MEDIAFORM CD-5900

The CD-5900 will duplicate up to 48 650mb CD-Rs per hour, and with add-on tower units can duplicate up to 16 CDs simultaneously. **That's almost 100 CDs per hour!** Call for details on this new low priced powerhouse from MediaFORM & AMC.

MediaFORM Duplicators selected as E-Media Magazine's "Editor's Choice" 2 years in a row!

BUY NOW with purchase of 100 CD-Rs FREE!



CD-5400 CD Duplicator (1-4).....starts at \$2,199
CD-5900 CD Duplicator (1-8).....starts at \$3,099
CD-5916 CD Duplicator (1-16).....starts at \$4,299
CD-3702 100 CD Duplicator (1-2)starts at \$4,899
CD-3704 100 CD Duplicator (1-4)starts at \$5,999
CD-3706P 175 CD Duplicator w/Printer (1-6)...starts at \$13,799

* Offer good only on select MediaFORM CD-ROM Duplicators. Call for details.

secure online ordering!
www.amc-direct.com

CD-R PRINTERS

PRIMERA SIGNATURE II COLOR CD PRINTER

\$1,049



The Signature II CD Color Printer from PRIMERA is the perfect way to add a professional touch to your CD-Rs.

PRIMERA TECHNOLOGY, INC.

CD-ROM SERVICES

AMC/iS

AMC's Imaging and Information Services division can provide you with:

- Mastering • CD-ROM Replication • Duplication
- CD-R Printing • Packaging • Silk-screening

Call us at **877.252.2882** or visit our Website at www.amciis.com

CD-R MEDIA

MITSUI RICOH



DiscWRITE Blank (no logo) 50 pk w/ jewel case\$69.99
Mitsui CD-R (silver) 25 pk w/jewel case\$45.00
Mitsui CD-R (silver) 100 pc spindle.....\$149.00
CMC CD-R Printable (white) 50 pc bulk.....\$59.99
Ricoch CD-RW 10 pk\$89.99
Samsung CD-R (silver) 100 pc bulk\$115.00
Verbatim CD-R (silver matte) 100 pc bulk.....\$169.00
AMC DiscWRITE special formulation CD-R Pens 4 pk.....\$6.95

IMAC PERIPHERALS

FOR USB - CALL AMC!



AMC has a complete selection of USB peripherals for your iMac, including scanners, printers, digital cameras, joysticks, hubs, cables, etc.

Check our Website for our complete selection today!

Advanced Multimedia Concepts • P.O. Box 3456 • Redmond, Washington 98073-3456 • 877.252.2882 • www.amc-direct.com

AD CODE: MW1099 **CALL US TODAY! 877.252.2882**

Choose 420 at www.macworld.com/getinfo



Aeron Chair
800-883-9697
www.sittingmachine.com

Choose 422 at www.macworld.com/getinfo

LOWEST PRICES! ON CARTRIDGES!

Guaranteed Compatible With
EPSON

Standard Inks: Fits Epson Series

INK4ART BRAND CARTRIDGES	EPSON	Price
Black-400,440,600,640,700	\$14.99
Black-740,800,850,1520	\$15.99
3 Color all above models	\$18.99
Photo Color Photo, Photo EX, 750,700	\$18.99

New Improved Inks!
Call for pricing on cartridges for Canon printers.

Specialty Inks: Fits Epson Series

Water Resistant/RAIN RESISTANT	Price
Black-400,440,600,640,700 Photos,EX \$25.99
Black-740,800,850,1520 \$27.99
3 Color All \$29.99
5 Color Photo Ex \$29.99

Call About Our New Sublimation Inks!

Check out the Cartridge Café Website Regularly for Cool New Products!

Check Out Daily Specials Online!
www.Ink4Art.com

Choose 424 at www.macworld.com/getinfo

3 Black
3 Color

6 pack to go!
\$59.99

inkfinity

The High Capacity, Low Cost Printing System.
This New EPSON Inkjet Printer has a High Yield Printing System.
Coming Soon! Place your order today!

Specialty Papers:

Paper Canvas	10 pack.....	\$9.99
	100 pack.....	\$49.98
Waterproof Photo Glossy	10 pack.....	\$4.99
	100 pack.....	\$29.99
INKY Shrinky Heat Shrinkable Ink Jet Composite Film. Use it to make Keychains, Name Badges, Christmas Ornaments, Jewelry and more!	10 pack.....	\$19.99
	100 pack.....	\$99.98



The Brand That Fits. Guaranteed!

TOLL FREE
1-877-695-1477

Custom ULTRA-2 LVD SCSI Cables - Terminators - Cases

If you want Ultra SCSI Performance use our Teflon Cables & Active Terminators.

Our knowledgeable SCSI Technicians will solve all your SCSI problems... guaranteed!

SCSIVue™ Active Terminator



Four models available with optional Remote LED Pak. These are the finest terminators available, they fix SCSI problems and improve reliability.

- Benefits:
- Improves SCSI Bus Performance
 - Less Errors; More Reliable Data Transfer
 - Diagnoses Problems • Analyzes Signal Quality

Active 2-1 SCSI Switch / Repeater

- Benefits:
- Up to 14 Devices to 1 Computer
 - Share Devices Between 2 Computers
- Features:
- 2-1 Active Digital Switch/Repeater
 - Regenerates SCSI Signal for Long Runs

Gold Diagnostic Adapters

- Both 50 pin and 68 pin (all combinations)
- Gender Changer

- From: \$49
- 68 pin Drive to 50 Bus
 - 68 Pin Drive to 50 Pin IDC (runs wide drive as narrow)
 - 68 Pin External Adapter to 50 Pin (converts Host Adapter)
 - 48 Pin to 50 Pin Centronics or 50 Pin Micro Adapter

- Styles: For Adapter Ultra Wide Cards
- Adapters with partial termination built in for 68 to 50 converters (converts Host Adapter)

Online Catalog at... www.scsiopro.com

SCSIVue™ Gold Diagnostic Cables

- Benefits:
- No Loss Of Important Data
 - Faster Performance
 - Test Cable Integrity
- Features:
- Diagnostic Indicators • Large Ferrite Filters
 - Triple Shielding (Unique Design)
 - Double Gold 20u" Plated Connectors
 - Extra Heavy 26 Gauge Wire • 100 Styles in Stock

Teflon® 90 Ohm External Cables

- From: \$39
- Benefits:
- Ultra SCSI 40 MB/s operation
 - Fixes Ultra SCSI Cable Problems
- Features:
- Perfect 90 Ohm Impedance Match
 - Triple Pronged Connector With Gold contacts

Hot Swap Powered Terminator

- From: \$69
- Now you can safely remove any SCSI device from a SCSI chain by simply flicking a switch. The Hot Swap Powered Terminator also has an optional Power Supply so that it can supply termination power to portable setups or when termination power is not being supplied.

Granite Cables Are The Best Because They're Engineered Right.

Granite Cables were designed by SCSI Engineers to be the Best Cables On The Market. Everything about them means better performance and higher reliability. Our design incorporates an exclusive shield that protects the Acknowledge and Request lines from noise. Large Ferrite beads are installed on all cables to protect them from static and noise. Every cable incorporates a LED indicator that lets you know it is operating properly. We also use more GOLD on every cable. Add to this our impedance matching techniques and you have most of what makes us THE BEST!

Granite
DIY+G+H+P+AL

Choose 423 at www.macworld.com/getinfo

External Ultra SCSI Cases

- 1 Ultra SCSI Custom Teflon Cable Available
 - Custom Enclosures in 1 Day for RAID & Arrays
- From: \$99

Temperature ALARM! Automatic Monitor & Control

- 14 & 29 Bay Ultra SCSI Towers
- From: \$999

- OPTIONS:
- Ultra LVD Cable Kit
 - Dual Redundant PS
 - Bay Coolers w / Brk
 - Temp Alarm System

Bay Cooler Kit keeps those HOT Ultra SCSI Drives GOLD as ICE!

- Dual Fan & Bracket \$29
- HOT SWAP Pull Out Bays Compatible with all 50 pin & 68 pin SCSI Buses up to Fast SCSI 2. From: \$79

(LVD)-TPO Teflon® Internal Cables

- Benefits:
- Less Errors, Ultimate Performance From: \$39
 - Silver Wire Improves Signal Quality \$39
- Features:
- Perfect 90 or 132 Ohm Impedance • Custom in 1 Day
 - Triple Pronged Connector • Gold contacts Silver Wire

50 Pin Replacement Cable for Internal Drive Enclosures

48 Pin Replacement Cable for External Drive Enclosures

From: \$99 Active Digital SCSI Repeater

- Benefits:
- Models for all SCSI types
 - Fixes SCSI Cable Problems
 - Doubles Cable Length (up to 18')
- Features:
- Active Termination and Signal Purification
 - Ultra Fast Performance for Added Capabilities
 - Diagnostic Capabilities • 30u" Gold Contacts

SCSI Cable Tester - LED Readout

This Digital SCSI Cable Tester can test all the popular cable styles for opens, shorts, and unreliable operation. Battery powered for easy use anywhere you need it.

- Three models to choose from:
- 50 pin IDC
 - 50 pin Centronics
 - 68 pin MicroD
- From: \$39

FREE Technical Support!!!
Available to everyone, customer or not.

3101 Whipple Rd. Union City, CA. 94587 Ph: 510-471-6442 Fax 510-471-6267

Mac Sales
www.macs4sale.com

Apple 20" Color Multiscans Sale \$599

Computers
Centris 610 24/230/monitor \$199
Centris 650 24/230/monitor \$199
Quadra 800 24/230/CD \$249
PowerMac 7100/80 24/1gb/CD \$399
PowerMac 8100/80 24/1gb/CD \$449
PowerMac 7500/80 32/1gb/CD \$699
PowerMac 8500/80 32/4gb/CD \$899

Monitors
13" Apple Color Monitor \$99
14" Apple Color Display \$129
17" Apple Color Multiscan \$279
20" Apple Color Multiscan \$599

Laser Printers
Personal LW / LW NT 300DPI \$199
Personal LW 4/600 600DPI \$449
Laserwriter 600 600DPI \$499

Extras
Kingston 16mb 72pin New Ram \$29
PowerBook Duo 20x86 Ram \$69
Duo Dock with upgrade Lid \$59

* See our web page for Future Ads *

1-888-MACSALE
Buy • Sell • Repair • Parts

Toll Free 1-888-622-7253
Inquiring about our products?
Products are listed in Macworld magazine.

www.kiwimac.com

Upgrades
Logic board upgrade prices are with exchange.
PowerMac 7200/90 to 7600/132mhz.....\$375
PowerMac 7200/120 to 7600/132mhz.....\$349
Performa Quadra 630 to 6200/75mhz.....\$149
Performa/Quadra 630 to 6300/100mhz.....\$249
Performa/Quadra 630 to 6360/160mhz.....\$425
Performa 6200 to 6360/160mhz.....\$325
Performa 6200 to 6500/275mhz.....\$449
Performa 6300 & 6320 to 6360/160mhz.....\$275
Performa 6300 & 6320 to 6500/275mhz.....\$389
Performa 6360 and 6400 to 6500/275mhz.....\$369
Performa 6200 to 5500/275mhz.....\$449
Performa 5260 & 5300 to 5500/275mhz.....\$389
Math Coprocessor for P630 & P575.....\$49
PowerBook 190 series to 5300/100mhz.....\$349
PowerBook 1400cs upgrade to active matrix.....\$399

Parts
Logic board prices are with exchange.
Performa 630 logic board.....\$49
Performa 6200 logic board.....\$149
Performa 6360 and 6400 logic board.....\$288
PowerMac 7200/90mhz logic board.....\$89
PowerMac 7200/120mhz logic board.....\$125
PowerMac 6100 logic board.....\$125
Performa 630/6200/6300 power supply.....\$49
Performa 6400/6500 power supply.....\$49
Internal 56k modem for 6360, 6400 and 6500.....\$115
1.44 internal floppy drive.....\$28
Apple Design Keyboard.....\$22

Visa/Mastercard/American Express No Surcharge

1-800-334-5494
www.kiwimac.com
Kiwi Computers • Established 1988

800-673-MACS
916-652-1880 FAX 916-652-1881 800-673-6227
www.poweron.com
Visit our Online Catalog

24x Macintosh Ready! BOOTABLE
Includes Driver Software
intech CD-ROM speedtools
\$109 External **\$79** Internal

E-TECH GOLD
Macintosh Ready
56K v.90 Data/Fax Modem
\$79

Power Macs
PowerMac 6100-60 8/240 (U) Power PC 601 60MHz Upgradable to G3 **\$199**
PowerMac 7100-80 8/500 (U) Power PC 601 80MHz Upgradable to G3 **\$299**
PM 6400-200 16/2.5G/CD (U) Power PC 603c 200MHz Incl. 28.8 Modem **\$599**
PM 7600-120 16/1.2G/CD (U) Power PC 604 120MHz Includes Ethernet **\$679**

HDs & CDs
4GB SCSI **\$199**
Apple EPROM

ZIP/HD/CDROM Install Kits IN STOCK
CD External Cases-SCSI cb1 incl (N) 29.99
HD External Cases-SCSI cb1 incl (N) 49.99
Panasonic 2x CDROM-External (N) 49.99
Apple 500 MB SCSI-Internal 3.5" (P) 59.99
1.2 GB SCSI-Int 3.5" (P) 99.99
2 GB SCSI-Int 3.5" (P) 129.99
4 GB SCSI-Int 3.5" (P) 199.99
Apple Floppy Drives-Auto (N) 99.99
Apple Floppy Drives-Manual (P) 59.99

Monitors
Apple 13" RGB Display (U) 99.99
Apple 14" M1212 Display (U) 119.99
HD External Cases-SCSI cb1 incl (N) 149.99
Apple 15" AV Multiscan Display (U) 179.99
Apple 17" MS Display (U) 199.99
Radius 20" Precisioncolor 20v (U) 299.99
Radius 20" Intellicolor 20e (U) 399.99
ATI MACH 64 MB PCI (OEM) 59.99
NUBUS Video Cards (from) 29.99

PowerBooks
PB160 8/80/Modem (U) 68030 25MHz 1.44 FDHD 10" Supertwist LCD **\$199**

Networking
Global Village 28.8/33.6 Modem PCMCIA PC Card **\$59**
33.6 flash upgradeable

Printers
StyleWriter 2500 (N) Includes: Black Ink & Cable **\$149**
Inkjet Cartridges & Supplies Papers * Transfers * Cartridges Top Quality Remanufactured Laser Toner Cartridges Apple®, Canon®, Epson® and Hewlett-Packard®

Keyboard•Mice
Apple Mouse I 22.99 JoyStick-MacAly (N) 29.99
Apple Mouse II 32.99 Gamepad-MacAly 29.99
Mouse, 1 button-N 16.50 Trackball-MacAly 29.99
Mouse, 2 button (N) 25.99 Apple ExtKybd II (U) 29.99
Apple ExtKybd I (U) 25.99 Ext Keyboard (N) 29.99
USB iKey (N) 39.99 USB Mouse (N) 29.99
USB HHub (U) 49.99 USB Ball (N) 39.99

Norton Utilities 4.0 or Mac OS 8.1 Your Choice \$29.99

WE BUY MACS
FAX TO 916-652-1881

MasterCard Discover Visa
* All Sales Final. No Cash Refunds Given
* All Prices include 3% cash discount
* Prices subject to change without notice
* Govt & School PO's Accepted
All brand or product names are registered trademarks of their respective holders and are respectfully acknowledged.

BUSINESS INDIVIDUAL EDUCATION

your complete used Mac resource

Mac of All Trades takes the fear out of buying and selling used equipment.

Mac-savvy advisors
Fast turn on payments
Custom configurations
We accept POs
Refurbished and tested...
Guaranteed in writing!

800-304-4639
Direct: 404-355-5713
Fax: 404-355-5461
500 Bishop Street, Suite E-3
Atlanta, Georgia 30318

MAC OF ALL TRADES

macofalltrades.com

SHREVE Systems

For all this and more check out our website!

http://www.shrevesystems.com



WE BUY MACS & MAC STUFF (318) 424-9791
WE STOCK MAC PARTS!
1-800-227-3971

FAX (318) 424.9771 • Technical Support (318) 424.7987
 Customer Service (318) 424.9791 • Purchasing/Information (318) 424.9791
 1200 Marshall Street • Shreveport, Louisiana 71101

Newton 130
 • ARM 610 RISC processor at 20 MHz
 • Back-Light LCD display
 • 8 MB RAM, 2.5 MB ROM
 • FREE W/ PURCHASE
 • Newton Fax Modem
 & Leather Newton Carry Case
 Lid not included
\$179

PowerMac 6500/275
 • 48MB of RAM
 • Iomega ZIP™ Drive
 • 6GB Hard Drive
 • 24X CD-ROM
 • 275-MHz PowerPC 603e
 • Refurbished
\$849
IN STOCK!

PowerBook 5300cs
 • Supports ext. video
 • 24MB RAM
 • 750 Hard Drive
 • 100-MHz 603e
 • Dual-scan color
 • Refurbished
 Carrying Case!
\$629
FREE!

Macintosh LC580
Internet Ready! \$399
 • 33-MHz MC68LC040
 • 8MB of RAM
 • 800MB Hard Drive
 • 28.8 Motorola Modem
\$499 with internal 4XCD
 Last Chance Blowout!

PowerMac Upgrades
Quadra/Centris 610 to PowerMac 6100/60 (refurbished)
As low as \$199!
 with exchange of your working board

Quadra/Centris 650 to PowerMac 7100/80 Upgrade (refurbished)
As low as \$199!
 with exchange of your working board

Quadra 800/840av to PowerMac 8100/80 (refurbished)
As low as \$249!
 with exchange of your working board

PowerMac 7200 to PowerMac 8500/132 (refurbished)
As low as \$399!
 with exchange of your working board

Performa 6200/75 120-MHz Upgrade (refurbished)
As low as \$299!
 with exchange of your working board

6500/225
 • 32 MB RAM
 • 2 GB hard drive
 • 12x CD Rom drive
NEW!
Factory Refurbished

TI MicroLaser Pro E
 • 600 dpi
 • 12 ppm
ONLY!
\$599

G3 Logic Board
 No Processor
only \$399

Quadra 950
 • 8MB of RAM
 • 68040 33-MHz
 • 5 Nubus Slots
 New **\$349**
NEW!

MACINTOSH LOGIC BOARDS

G3 logic board, No Processor, No ROM	\$399.
7200/90 logic board, refurbished	\$299.
LC logic board, refurbished	\$49.
LC II logic board, refurbished	\$149.
Mac LCIII logic board, refurbished, exchange	\$199.
Performa 630, No Processor, refurbished	\$99.
7500 logic board, no exchange	\$379.
8500 logic board, exchange	\$449.
9500 logic board, exchange	\$649.
Quadra 950 logic board, refurbished	\$199.

PRINTERS

Apple 11x17 Color Inkjet Printer NEW, #M9500	\$249.
Apple StyleWriter 1200, refurbished	\$149.
Apple StyleWriter 4500, factory refurbished	\$199.
Apple Color StyleWriter 2400, refurbished	\$199.
Color StyleWriter 4300, refurbished	\$269.
LaserWriter 8500 (tabloid, fast engine) refurbished	\$1149.
LaserWriter III, refurbished w/ Toner	\$199.
LaserWriter III w/5MB RAM, refurbished	\$549.
LaserWriter IIg w/5MB RAM, refurbished	\$649.
Texas Instruments Micro Laser Pro E NEW	\$599.
NEC SilentWriter 1765, 17ppm! NEW	\$699.

Laser toner cartridges sold separately

Color LaserWriter 12/600PS

- 600-dpi
- 12 ppm
- Color Photograde
- LocalTalk, Ethernet
- Mac, DOS, Unix or Windows
- Toner included

Refurbished \$1299

PowerMac CPU SALE!

4400/200 32/2GB/CD \$679 refurbished	6500/250 32/4GB/CD \$749 refurbished
9500/120MP 16/1GB/4X \$999 refurbished	7250/120 32/2GB/8XCD \$799 NEW!
8500/132 0/0/0 \$599 refurbished	6500/300 64/6GB/CD/Zip56k \$1049 refurbished

REFURBISHED POWERBOOKS

540c 12MB/320MB/ Color Active-matrix	\$599
PowerBook 3400c/180 16MB/1GB/12XCD, Color active-matrix	\$1199
PowerBook 150 4MB/120MB	\$429
PowerBook 3400c/240 16MB/3GB/12XCD, Color Active-matrix	\$1399
PowerBook 1400cs 16MB/1GB/6XCD, Active-matrix color	\$1099

VIDEO CARDS

ATI XClaimVR RAGE II 2MB with FREE TV Option	\$149.
E-Machines DoubleColor SX Nubus Card NEW	\$49.
RasterOps 24MX NEW, 24-bit Nubus	\$149.
Supermac 8.24 PDQ Plus, 24-bit Nubus card	\$449.
*PowerMac HPV Card (1MB)	\$79.
*PowerMac A/V Card (2MB)	\$199.

MONITORS

AppleVision 850 Display, refurbished	\$699.
Apple 14" A/V NEW	\$249.
Apple 14" Multiscan, refurbished	\$149.
Apple 15" Multiscan, refurbished	\$229.
Apple 15" AV, factory refurbished	\$279.
Apple MultiScan 17", refurbished	\$249.
Apple 20" Multiscan, refurbished	\$699.
Radius IntelliColor/20x, factory refurbished	\$999.
Vxcon 14" Multiscan NEW	\$179.
Vxcon 15" Multiscan NEW	\$229.
Radius Color Pivot LE, refurbished	\$199.

APPLE PC COMPATIBILITY CARDS

Pentium 100-MHz, refurbished	\$149.
Pentium 166-MHz, 12" PCI card, refurbished	\$299.
586 100-MHz, 7" PCI card, refurbished	\$99.
486 66-MHz for 6100 series, NEW	\$29.

FREE PC CD pack with PC Card Purchase!

NUBUS ADAPTERS

Quadra 660AV NuBus Adapter	\$79.
Quadra 610 NuBus Adapter	\$79.
Ilisi NuBus adapter with math co-processor	\$69.

IMAGING PRODUCTS

Apple Color OneScanner refurbished	\$199.
UMAX UC840 Scanner NEW	\$199.
Apple QuickTake 200 refurbished	\$219.
Apple QuickTake 150 refurbished	\$199.

Save A Mac Foundation

MacAly Extended Keyboard
NEW!
\$19

NEW 7200/75 LOGIC BOARD
ONLY \$99
Logic Board Blowout!!

G3 Upgrade Cards
 Is your computer too slow?
 Speed up your Mac and shatter the speed barrier!

1.44 SuperDrives
STARTING AT \$49!
NEW!
NO EXCHANGE REQUIRED!

\$39
 Genuine Apple ADB Mouse II
NEW!
XClaim VR with FREE XClaim TV!
NEW OEM \$149
 • 3D RAGE II, 2MB VRAM

ClarixWorks 4 Internet Edition
NEW!
FREE Clarix HomePage!

QuickTake Cameras
 Refurbished
STARTING AT \$129!!

*Products are refurbished unless indicated as "new". Prices reflect a 2% cash discount and are subject to change without notice. Returns are subject to a 15% restocking fee. Not responsible for typographical errors. All trade-ins MUST BE in working condition. Refurbished systems may include like-new components and may also include cosmetic blemishes which do not functionally impact performance of the hardware.

DIGITAL PREPRESS SYSTEMS

Specializing in Rebuild Imagesetters
(714) 892-5290 Fax: (714) 892-4361

ALL MAKES & MODELS Complete Prepress Systems

e-mail: prepress77@Hotmail.com
 Huntington Beach, California USA

<p>SPOT COLOR SYSTEM</p> <p>INCLUDES: G3-MAC, Scanner, RIP, Imagesetter, Proof Printer, Processor & Software \$16,250</p> 	<p>SAPHIR SCANNERS</p> <p>FACTORY REFURB: 1 yr. Wnty, Saphir, Saphir Ultra, Ultra 2, Hi-Res, Opal Lino-color from \$850</p> 	<p>HARLEQUIN RIP</p> <p>Software, PS Level 3 MAC OS, WIN 95, WIN NT Compatible for most Imagesetters \$4,695</p> 	<p>PROCESS COLOR SYSTEM</p> <p>INCLUDES: G3-MAC, Scanner, RIP, Imagesetter, Proof Printer, Processor & Software \$22,500</p> 	<p>SILKSCREENING</p> <p>IMAGESETTER: Agfa or Linotype 18" wide Hi-Quality Film - Pos Separations \$15,000</p> 
<p>PLATEMAKING SYSTEM</p> <p>Refurb-Digital Platemaking Imagesetter, PS RIP Processor, Densitometer, Calibration Software 150 LPI. From \$10,000</p> 	<p>HOWTEK DRUM SCANNER</p> <p>D4000: 4000 dpi, 3.9 Dyn Range, 6 bit, CYMK, RGB, Factory Refurb, Desktop Size \$7,150</p> 	<p>SCITEX DOLEV</p> <p>SCITEX DOLEV Drum Imagesetter: 200 - 2Up \$9,500 400 - 4Up \$18,000 800 - 8Up CALL</p> 	<p>ECRM-NEW & REFURB</p> <p>MARLIN: 18" w/Punch & Harlequin RIP. NEW \$56K MAKO 4625: Best Priced New 18" Imagesetter w/ Harlequin SW RIP \$33,300</p> 	<p>BEST OF THE REST</p> <p>Macintosh G3, PC Pentiums, All Prepress Software, File Servers, Networking Hubs & Switches, Color Proofing Printers & Match Print Equipment</p>

TRADE YOUR MAC FOR A NEW ONE. We Pay Top \$\$\$ For Your Mac & Mem.
 CALL FOR UPGRADES Email: cgn @ cgnusa.com **BUY • SELL • TRADE 310 441-4771**

<p>PowerMacs</p> <p>G3 400 Mhz 128/12gb 2475 G3 350 Mhz 64/6gb/CD 1490 G3 300 Mhz 64/4/CD 1390 G3 233 Mhz 32/4GB 1390 9600 300 MHZ 1790 G3 350 MT 1550 7200 16/500 299</p> <p>Call for G3 Units</p> <p>G3 266 Mhz 1390 7200 /75/90/120 CALL Call for config. not listed</p>	<p>Powerbooks</p> <p>G3 400 Mhz DVD 3190 G3 333 Mhz CD 2370 G3 266 Mhz CD 1890 G3 233 Mhz 1495 G3 250 Mhz CD 1295</p> <p>PB 233 32/4/CD 1350</p> <p>Demo Powerbooks</p> <p>Call For G3 Demo PBs</p> <p>540C 12/500/Mod 450 5300c 16/750 549 520-170-180c-165c CALL PB 1400 16/1/CD 845</p>	<p>Upgrades</p> <p>Same day Upgrade No down Time!!</p> <p>PB 3400 to PB G3 250 599 7200 to 7600 395 8100 to 8500 429 7500 to G3 250 Mhz 390 CALL for G3 Updges !!!</p> <p>Perf 63xx to 6500 225 399 9600 to G3 400Mhz CALL Q 610/660 to 6100 169 Q800-840 to 8100 349</p> <p>Call for PowerBook Upg. Call for Upgrades not listed</p>	<p>Demo Macs</p> <p>8500 32-1gb-cd 695 7600 32-500-cd 595 7200 16/500/cd 350 9600 200 1390 7300 180/16/1/CD 799 G3 233 16/4/CD 1099 9600 300 1775 Quad. 610 \$ 79</p> <p>Special</p> <p>Quadra 610 \$ 79 Quadra 630 \$199</p>	<p>Storage</p> <p>CD 2X-4X-12X-24X Call CD Recod. Yamaha 4x2x6 435 Yamaha 4x4x16 359 Yamaha 4x6x24 Call</p> <p>Exchange ON : Logic Boards, Power Supply Call</p> <p>Call For: Monitors, Printers, Scanners, All Apple Parts In Stock and We do Advance exchange. Leasing Available.</p>	<p>Parts</p> <p>Floppy 1.44 45 POWER SUPPLIES CALL AV Card \$150 Power supply Cx Cj 7100 35 Call for Logic Boards & more</p> <p>Computer Graphics & Networking</p> <p>All prices Reflect cash Discount Visa, Mastercard, Amex Accepted << Prices are subject to Change.>></p>
--	---	--	---	--	---

TEL: 310-441-4771 10922 W. Pico Blvd. Los Angeles, CA 90064 Fax: 310-441-4770
 Choose 429 at www.macworld.com/getinfo

MacWorks 800-482-2705 e-mail: sales@macworks.com
 Starting the Macintosh community since 1984
 Voice 913.599.6227 • Fax 913.599.6111 • 9am-6pm Mon-Fri CST
 Prices Subject to Change • Visa/MasterCard/AmEx
 We ship FedEx • 15% minimum restocking fee on all returns

<p>Apple/Motorola G3/333 MHz ZIF Processor Cards</p> <ul style="list-style-type: none"> 333/167 MHz, 1MB Brand New, 2-Year Warranty \$20 trade-in for your old (working) ZIF module Upgrades G3 desktop/minitower Upgrades PCI PowerMacs with an XLR8 Carrier ZIF Card (get Carrier ZIF for \$149.99 with purchase of G3 ZIF Card)  <p>ONLY \$199.99</p>	<p>Performa 6400/180</p> <ul style="list-style-type: none"> 16/1.6GB/6/CD/28.8 Upgrade to Sony 12x/CD at no extra charge! 30-day warranty  <p>ONLY \$499.99</p>	<p>PowerMac Bundles</p> <p>Includes monitor, keyboard, mouse, modem Upgrade any bundled CD to a Sony 12x FREE! Add Color StyleWriter 2500 for only \$149.99</p> <p>7500/100 24/500/4x/17" \$799.99 6400/180 16/1.6GB/3x/17" \$649.99 7200/120 32/1.2GB/3x/17" \$649.99 7100/80 16/500/2x/17" \$599.99 7100/66 24/500/2x/17" \$499.99 6100/60 8/160/13" RGB" \$249.99</p> <p>*Add a Sony 12x/CD to this bundle for \$39.99</p> <p>FROM \$249.99</p>	<p>Apple Monitors</p> <p>20" ColorSync \$999.99 17" ColorSync \$499.99 17" MultiScan \$299.99 17" AppleVision 1710av \$299.99 17" MultiScan 720 \$279.99 14" Color Display \$129.99 14" Color Plus Display \$99.99 13" Hi-Res RGB \$99.99 12" RGB \$49.99 12" Monochrome \$39.99</p> <p>FROM \$39.99</p>	<p>RocketFire 6-Port FireWire Hub</p>  <ul style="list-style-type: none"> Brand New, 1394a-Compliant Mac & PC Hot-Pluggable Data Transfer Rates up to 400 Mbits 1-Year MacWorks Warranty <p>ONLY \$399.99</p>
--	---	---	---	--

<p>Sony 12x CD-ROM</p> <ul style="list-style-type: none"> New, Internal Includes FWB Meads trouble Uses Apple Mounting Kits (\$25) 90-day warranty  <p>ONLY \$79.99</p>	<p>Apple Upgrades</p> <p>iMicro EMB Ultimate Rez \$99.99 ATI XClaim 3D 4MB PCI Video \$89.99 ATI XClaim VR 4MB VRAM \$49.99 Apple MPEG Media System \$49.99 61xx DOS Card w/ Win 3.1 \$39.99 LapseColor Vid/Eth for PB 5300 \$99.99 6x CD-ROM for PB 3400 \$69.99 PB Duo Replacement Keyboard \$59.99 PB Duo 14-4 Express Modem \$49.99 PB Duo AC Adapter \$49.99 PB Duo Ext. Batt. Recharger \$19.99</p>	<p>Parts/Accessories</p> <p>Replacement Logic Boards CALL Power Supplies CALL 3.6v Lithium Battery \$19.99 Internal Floppy Drives \$49.99/\$79.99 Apple Extended Keyboard \$39.99 Apple Design Keyboard \$19.99 Apple Desktop Bus Mouse II \$49.99 MacPower 2-Button Mouse \$29.99 Apple Microphones from \$9.99</p>	<p>Software Bargains</p> <p>AppleShare 4.1 \$149.99 Mac OS 8.1 CD-ROM \$49.99 Mac OS 7.6 w/ClarisWorks 4 \$49.99 Apple Internet Server Solution I \$49.99 ClarisWorks 5 OEM \$39.99 Norton Utilities 4 x OEM \$39.99 SmCity 2000 CD-ROM \$129.99 Apple Font Pack \$9.99 Apple Personal Diagnostics \$7.99 Children's Software from \$9.99 Stock Photo CD-ROMs from \$9.99 PDS Training CD-ROMs from \$9.99</p>	<p>Printer Accessories</p> <p>Color LW 250-Sheet Feeder \$99.99 LW 12/640 500-Sheet Feeder \$99.99 LW Select 500-Sheet Feeder \$99.99 LW Pro 6xrt Envelope Feeder \$69.99 Personal LW 250-Sheet Feed. \$29.99 Color SW 2200 Batt. Attach. \$49.99 Color SW 2200 Battery \$19.99 Color SW 2200 Black Ink \$14.99 Color SW 2200 Color Ink \$14.99 Apple Color Printer Black Ink \$14.99 Apple Color Printer CMY Inks \$9.99 Color SW Pro Black Ink \$9.99</p>	<p>LaserWriter 8500</p> <ul style="list-style-type: none"> 600dpi, 20ppm 11x17, Ethernet PostScript 3 Used 30-day warranty No toner; add a new toner cartridge for \$100 more  <p>ONLY \$999.99</p>
<p>Quantum Fireball 4.3GB SCSI</p> <ul style="list-style-type: none"> Manufacturer Refurbished Internal SCSI Hard Drive Quantum Model # ST43S011 <p>ONLY \$199.99</p>	<p>Apple GeoPort Adapter I</p>  <p>\$19.99</p>	<p>Newton 120</p> <p>2mb/modem \$179.99 1mb \$139.99 software bundle \$49.99</p>	<p>www.macworks.com</p>		

The Lowest Finance Rate

Ultimate Scan-Station (Drum scan quality)

Get the Apple Blue G3/466MHZ or UMAX S900 G3/466MHZ Scan-station for only \$299 per month! It includes the fastest Mac yet, and it comes with all the hardware tools you need to blast through production work. Save a bundle with this exclusive package!

CERTIFIED REPAIR SERVICE CENTER
COMPUTER, MONITOR, LASER/PRINTER REPAIR, TONER REFILL, POWER SUPPLY, SHORT TERM RENTAL AVAILABLE.

PLUG&PLAY
\$299
PER MONTH



PowerMac G3/466 Mini-tower Ultimate Graphics Workstation

- Apple Blue G3/466MHZ or UMAX S900 G3/466MHZ
- Internal 32X CD-ROM
- **512MB RAM**
- 20 GB hard drive - AV /ATAPI
- Extended keyboard & Mouse
- **SONY 19", 1600 x 1280 monitor**
- **ATI Rage 128 Graphic accelerator card, 1600x1200, w/16MB**
- **UMAX PowerLook3000 - 3000 dpi color scanner w/ Transparency**

- **PowerLook3000** can scan negative, reflective, slides & 4X5 films
- **Binuscan PhotoPerfect** can do professional color correction
- **External combo drive w/ZIP, 9GB, CD-R**
- **Active SCSI terminator**
- **UPS Battery Back-Up**
- **Image Solutions Extended Services**

\$289

\$5769

\$699

\$89



\$449!
JAZZ-CD-R

COMBO Drives:	
9GB + CD-R Ext. SCSI	\$699
JAZ + CD-R Ext. SCSI	\$449
JAZ+ZIP+9GB+CD-R	\$1089
18GB AV + JAZ + CD-R	\$1099
36GB AV RAID + CD-R	\$1989

Basic Systems		Buy!	Lease!
G3/350 128/12GB/24XCD	w/17" monitor, XKeyboard, Mouse	\$1899	\$47
G3/400 128/17GB/ZIP/24XCD	w/19" monitor, XKeyboard, Mouse	\$2799	\$74
G3/450 256/20GB/ZIP/24XCD	w/SONY 21", XKeyboard, Mouse	\$4399	\$129
UMAX S900 - G3 96MB/9GB/CD	w/19" monitor, XKeyboard, Mouse	\$2399	\$59
PM8100-Targa 2000/96/4GB/CD Video Edit.	w/15" monitor, XKeyboard, Mouse	\$1899	\$47

PowerMac PM9600/G3 Video Editing Station

- PowerMac 9600 / G3 - 466MHZ
- 256 MB RAM, 6 PCI Slots
- iXMicro UltimaRez 8MB display
- Internal 24 x CD-ROM
- Quantum Atlas II 9GB SCSI III hard drive
- Extended keyboard & Kensington Mouse
- Sony 17" color multisync monitor
- JackHammer PCI SCSI III Differential
- 36GB RAID + JAZ + CD-R + ZIP COMBO Drive
- TrueVision Targa 2000 Pro Audio/Video Capture Editing PCI
- Epson 1200 Color Printer
- Premiere V5 & After Effect
- UMAX S1220 Scanner

PLUG&PLAY \$299 PER MONTH

\$9.99 A DAY!

\$2589

\$2489

Software Specials QuarkXpress4\$649

- Apple Mac OS 7.6/8/8.1/8.5 \$49/55/59/69
- Bryce3D/Poser3/Expression/RDStudio \$139
- Claris EMailer/DRAW/Calendar Maker \$69 ea.
- Claris Works V4/5/AppleWorks \$49/59/89
- Claris Impact/Organizer/HomePage \$69 each
- Caere OmniPagePro V5/8/Direct\$89/189/29
- Director V5/6/6.5/Studio \$199/289/389/489
- DeBabelizer V3/ Danitz Retrospect4.1\$199/99
- Extensis MaskPro2/PortFolio \$199/109
- Extensis PreFlight Pro/ PhotoFram \$269/89
- FileMaker Pro. V2.1/4/Server \$49/109/489
- Fontographer V4/Freehand V5 Studio \$199 ea
- Infini-D V4.5/ KPT 3/Painter5 \$439/79/99
- Microsoft Office4.2.1/97/98 \$99/179/199
- MediaCleanerPro4/QuarkXpress4\$289/649
- Norton Utilities/Anti-Virus Bundle \$79 both
- StrataStudioProV2.5/SoundEdit 16 \$635/249

\$49!

\$99!

Display & AV Card, XKeyboard

- ATI Xclaim VR VideoEdit/ ATI RAGE 128 16MB \$99/289
- Apple AV - In&Out -Exchange/Avid Cinema \$289/89
- Targa 1000PCI / 2000 NuBus -Demo \$1489*/\$789*
- Targa 2000PCI / 2000PCI Pro - Demo \$2489*/\$2889*
- Targa 2000 PCI RTX / SDX -Demo \$5889*/\$7889*
- MiroDC30*/MotoDV/Targa Break out box*\$589/889*
- XKeyboard w/Touch PAD / 56K Int. modem \$49/99
- Extended Keyboard - Japanese / English \$69/\$39
- Kensington 2-Button Mouse / Turbo Mouse \$29/95
- Apple USB Keyboard / 68-68 SCSI III Cable \$49/35

JAZZIP, Hard DR. & CDR Devices

	SCSI External	Turbo
400MB/1GB/2GB/3GB	\$99/159/189/209	+\$29
4GB/6GB/9GB/18GB	\$259/329/339/699	+\$29
Quantum Atlas II 4GB/9GB	\$299/489	+\$39
Quantum Viking LVD 9GB/18GB	\$459/729	+\$49
Quantum Atlas III 9GB/18GB	\$589/759	+\$59
Seagate 4GB Hawk/Barracuda	\$279/299	+\$39
Seagate 9GB Elite/Barracuda	\$349/469	+\$39
Seagate Cheetah 4GB/9GB	\$449/569	+\$49
Seagate 18GB Barracuda/Cheetah	\$769/989	+\$59
Jaz ext. Dr. 1GB/2GB	\$219/\$339	+\$29
Zip Dr. w/Cart. Int. / Ext.	\$109/\$125	+\$29
Teac 8X/12X w/Toast	\$49	+\$19
Yamaha CD-RW 4X/4X/16Xw/Toast	\$349	+\$29
Apple DVD-ROM Dr. w/MPEG Decoder	\$399	+\$29
ORB 2GB, DVD-RAM 5.2GB SCSI	\$195/\$699	+\$39

\$29/49*

\$199!

Close-Out Specials

- MAC IICX II/PP405 as low as \$169
- PM 6116CD 16MB/1GB/CDS\$389
- PM 7200 16MB/1GB/CD \$489
- PM 6500 32MB/3GB/CD \$889
- PM 9500 32MB/1GB/CD \$989
- 8GB F&W DiskArray \$689
- SyQuest 270/200MB Ext. Drive\$249/199
- Fujitsu 230MB MO /WANG DAT \$199 ea.
- SONY 650MB/1.3GB M.O. Dr.\$589/989
- Apple Japanese/Chinese Language Kit\$89
- Illustrator V6/PageMaker V6 \$199 ea.
- M.S. FrontPage/Project V4 \$99/289
- M.S. Words V5/V6/98 \$99/189/269

QuarkXpress V4.03 \$649

JAZ Int. Dr. \$199!

Super RAID- Atlas III or Barracuda SCSI III Fast & Wide, LVD

- AV Qualified High Performance Disk Array
- Low Voltage Differential Drive allows 12' SCSI Chain
- High Quality Construction. Gold Plated Connections.
- Features built in Cooling fan. SCSI ID, Metal frame.
- Grab handles of Removable drive for easy Plug-in-out.
- Key locking door to prevent unwanted removal.
- Stripping software - REMUS for RAID 0,1 & 5. - \$149
- Adaptec 2940U2W upto 80MB/sec. - \$335
- Adaptec 8945 FireWire & UltraWide SCSI - \$529
- JackHammer SCSI Fast&Wide Diff.\$399
- 18GB RAID - \$ 1189
- 36GB RAID - \$ 2089
- 54GB RAID - \$ 2989
- 72GB RAID - \$ 3689
- 144GB RAID - \$ 7399
- Add \$499 for Removable

Processor Upgrade

604E 150/180	\$69/99
604E200/225	\$189/229
UMAX 2nd -250MHZ S249	
G3 233/250	\$299/329
G3 266/300	\$349/389
G3 366/400	\$589/689

Philips 2X/4X CD-R Dr. only \$199!

IOMEGA CARTRIDGES

\$65*!

10mega

1.0GB Jaz	\$65*
100MB Zip	\$9*

\$9*!

Memory

	30/72 Pin	168 pin	G3
8MB	\$29	\$25	-
16MB	\$45	\$39	-
32MB	\$79	\$69	\$69
64MB	-	\$119	\$119
128MB	-	\$299	\$199
256MB	-	-	\$489

\$39! 16MB

Tape Ext. Drive

SDT-2000/4000	\$389/489
SDT-4000 - 8GB\$489	
SDT-7000 - 8GB\$789	
SDT-9000-24GB \$869	
DLT 30GB	\$1389
DLT 40GB	\$1849

800-352-3420

Fax: 310-782-5974
E-Mail: Imagesol4U@AOL.com
http://www.imagesolutions4U.com
385 Van Ness Ave. #110 • Torrance, CA 90501

Order from 7 to 6 weekdays, Saturday from 10 to 12. Visit our showroom 9 to 6 weekdays, weekends by appointment.
Prices subject to change without notice. Not responsible for typographical errors. 24 hour replacement limited to products in stock.

KINGSTON, VIKING, NEWER TECH. AVAILABLE

Image Solutions

The solution provider for print shops, service bureaus and imaging professionals

Mac POWER

Sales & Service, Inc.
BUY • SELL • TRADE
UPGRADE • REPAIR
New • Used • Refurbished
• Powrbooks • Monitors
• PowrMacs • Printers
• Performas • Peripherals
• Quadras • Ram
• MacII-LC • Parts
www.macpowerinc.com

888-275-POWER
Fax: 408-448-6132
San Jose, California, 95123

MEGA Macs.com

- Laserwriter Pro 630 \$449
- Norton Utilities 4.0 \$21
- 3Com Sportster 56K \$79
- IBM 4GB SCSI HD \$149
- Zip SCSI Internal \$69
- Apple Laserwriter IIg \$199
- Gold 56K External \$59

We have over 100 Software Titles for \$9.00/ea.
918-664-MACS(6227)
All Prices reflect 3% Cash Discount

THE BEST IN
REMANUFACTURED
Macintosh
COMPUTERS & PARTS

Fall Specials!

- Complete Power Mac Color System WITH MONITOR AND KEYBOARD **\$529!**
- StyleWriter 1200 Inkjet **\$99!**
- PowerBook 160 WITH MODEM **\$249!**
- PowerBook 1400 WITH PPC 603e PROCESSOR, COLOR DISPLAY STARTING AT **\$749!**
- iMacs STARTING AT **\$769!**

Pre-Owned Electronics
1-800-274-5343

Offices: 781-778-4600
Fax: 781-778-4848

www.preowned.com
DIS0075

Choose 431 at www.macworld.com/getinfo

MAC GLOBAL

SYSTEMS AND PERIPHERALS • SALES AND SERVICE

4770 ALMADEN EXPRESSWAY STE # M • SAN JOSE, CA 95118

PowerMacs	Powerbook
G3 233 DT \$1175	520 4/160 \$325
G3 266 DT \$1375	520c 12/240/19.2 \$450
6100 8/500 \$225	540 12/240 \$375
7200 8/500 \$325	540c 12/320/19.2 \$575
7500 16/500 Call	\$300cs 8/500 \$575
8500 16/1G Call	1400c.cs 11/7133/166 Call
9500 32/2G Call	
	Performas
	Memory
	4Mb 72-pin \$8
	8Mb 72-pin \$15
	16Mb 72-pin \$30
	32Mb 72-pin \$60
	410/466/476 Call
	580 5/500/CD Call
	631 8/500/CD Call
	6200 8/1G/CD \$399
	5200 8/500/CD \$699
	Printers
	StylWtr. II \$175
	StylWtr. 1200 \$155
	Laser 300 \$299
	Laser 320 \$449
	Laser 4/600 Call
	630 8/250 Call
	650/800/840/950
	Monitors
	13" RGB \$89
	14" Color \$149
	15" Appl. Mult. \$189
	17" Appl. Mult. \$315
	20" Apple Mult. \$550
	Software
	Mac OS 8.1 \$15.99
	*We repair Macs!

TOP DOLLAR Paid for Memory, Powerbooks, and CPUs

1-800-722-8864

PHONE: 408-265-6653

FAX: 408-265-6660

WWW.GLOBALDEALS.COM

Choose 433 at www.macworld.com/getinfo

Online Micro **800-720-4400**
www.onlinemicro.com
(714) 338-1900 Fax (714) 338-1905
Email: sales@onlinemicro.com

Desktop & Tower			
7200/90*	8/500/CD	\$329	G3/250/13.1**32/4GB/CD \$1449
7500/100*	16/500/CD	\$529	G3/266/14.1**32/4GB/CD \$1899
7300/180*	16/1.2/CD	\$799	G3/292/14.1**64/8GB/CD \$2099
4400/200*	16/2GB/CD	\$499	G3/300/14.1**32/4GB/CD \$2399
8500/120*	16/1GB/CD	\$649	DUO DOCK PLUS \$189
8500/150*	16/1GB/CD	\$799	Duo 2300c 20/1GB/Mod. \$649
8600/200*	16/2GB/CD	\$1199	
8600/300*	32/2GB/CD	\$1599	Printers
9500/132*	16/1GB/CD	\$799	SW4500 ALPS GLIDEPOINT TRACKPAD ADB FREE \$219
9500/200*	32/2GB/CD	\$1199	LW8500* \$799
9600/233*	64/4GB/CD	\$1599	
9600/300*	64/4GB/CD	\$2099	Monitors
9600/350*	64/4GB/CD/Z	\$2499	15"/15" av* \$139/\$179
G3/233DT*	32/4GB/CD	\$1049	750*/850/850av \$299/\$699/\$799
G3/266DT*	32/4GB/CD	\$1149	20" Colorsync* \$999
G3/266MT*	64/6GB/CD	\$1299	ViewSonic G810 21" \$889
G3/300MT*	64/8GB/CD	\$1499	SONY 220GS/420PS \$449/\$669
G3/333MT*	64/8GB/CD	\$1899	SONY 520GS 21" \$969
6360/160*	16/1.2GB/CD	\$459	HARD DRIVE
6400/180*	16/1.6GB/CD	\$489	IBM 4.0GB 50 pins SCSI \$149
6400/200*	16/1.6GB/CD	\$549	Apple 4.0GB UW SCSI \$249
6500/250*	32/2GB/CD	\$659	Seagate 18GB UW SCSI \$699
5200/75*	8/500/CD	\$599	USB 10GB external \$259
5400/200	32/1.6GB/CD	\$649	MEMORY
7100/80*	8/500/CD	\$329	64MB SDRAM/PC100 \$89/\$89
8100/100*	16/1GB/CD	\$489	128MB SDRAM/PC100 \$129/\$109
			256MB SDRAM/PC100 \$429/\$659
	Notebook		SONET TECH UPGRADE
1400CS/166*16/1.3/CD	\$799	G3/250Mhz/512 For PCI CPU	\$225
3400C/180*16/1.3GB/CD	\$1029	G3/300Mhz/512 For PCI CPU	\$370
G3/233/13.1**32/2GB/CD	\$1339	G3/333Mhz/1m For PCI CPU	\$499
		G3/400Mhz/1m For PCI CPU	\$629
		G3/366Mhz/1m cache Ziff	\$389
		G3/400Mhz/1m cache Ziff	\$479
		G3/466Mhz/1m cache Ziff	\$769

Choose 432 at www.macworld.com/getinfo

Local: (303) 571-1900
Fax: (303) 571-5020
Hours: M-F 9-6 Sat 10-5

MediaGuide

Your #1 Macintosh Source!

SHOP ONLINE!

Need a Mac?
Need stuff for your Mac?
We've got it.

NEW • USED • PARTS • RAM • PERIPHERALS & TONS MORE

www.MediaGuide.com

OEM CDs:	Brand New
MacOS 8.5.....\$49	Sony 24x CD-ROM
Norton Util 4.0...\$29	Int.....\$89
ClarisWorks 5.....\$29	Ext.....\$119
MacOS 8.1.....\$29	

HOT Bundle specials! (CPU plus 13/14 monitor, kb/m)
Ilii 8/425...\$179 • Ilii 9/230...\$169 • Ilii 8/425...\$199
Q650 16/425/CD...\$299 • Q630 20/250/CD...\$299
6100 24/350/CD...\$399 • 7100 40/425/CD...\$449
Many additional models available!

Apple 4.3 gig HD...\$149

Not online? No problem! Call (888) 466-2271

think mac
LIQUIDATION
dealer destroyer
BLOWOUT SALE

- 3 Apple Macintosh Quadra 650 24/230/CD w/Apple 14" Color Monitor Keyboard and Mouse ⇒ **\$499**
- 3 Apple Power Mac 61 or 7100/66 24/230/CD w/Apple 14" Color Monitor Keyboard and Mouse ⇒ **\$749**
- 3 Apple Power Mac 7100/80 24/500/CD w/Apple 14" Color Monitor Keyboard and Mouse ⇒ **\$999**
- 3 Apple Power Mac 7200/90 24/500/CD w/Apple 14" Color Monitor Keyboard and Mouse ⇒ **\$999**
- 3 Apple Power Mac 7200/120 24/500/CD w/Apple 14" Color Monitor Keyboard and Mouse ⇒ **\$1249**

dealer destroyer
PRINTER SALE

- Apple Laserwriter IINT.....\$179
- Apple Laserwriter IIF.....\$279
- Apple Laserwriter IIg.....\$499
- Apple Laserwriter Select 360.....\$599
- Apple Laserwriter Pro 630.....\$699
- Apple Color Laserwriter 12/660PS.....\$2799
- Tektronix Color Phaser 340.....\$2299

VISIT OUR NEW WEBSITE FOR OTHER APPLE PRODUCTS AND DEALS AVAILABLE
WWW.THINKMACLIQUIDATION.COM
TOLL FREE 877-638-2822

SCHOOL AND GOV'T PO'S ACCEPTED ALL MAJOR CREDIT CARDS ACCEPTED
Where the price is right and the service is priceless
1035 Sansonite Blvd. Suite C • Murfreesboro, TN 37129
PH: 615-904-1070 FAX: 615-890-1070

Think
COMPUTER
REVELATIONS



ALL APPLE PARTS & ACCESSORIES IN STOCK
Leasing
Rentals / Supplies
Service available in NYC area

1 800 275-9924
in NY 516 737-0800
FAX 516 737-0923

331E Dante Court
Holbrook, New York 11741

NEW & USED BOUGHT & SOLD

Choose 434 at www.macworld.com/getinfo

FOR MEMBERS ONLY



Only Macintosh User Group members enjoy access to a very special Apple-sponsored web site with super discounts on all the latest Mac stuff, MUG product awards and much more. Not a member? Find out how you can get these great deals by calling PowerMax at 800-689-8191.

www.applemugstore.com



MUG STORE



The MUG Store. A cooperative venture between Apple and PowerMax to bring MUG members exclusive deals on the latest Mac® products, as well as special offers on discontinued and factory refurbished Macintosh® computers.

PowerMax is a division of Computer Stores NW, Corvallis, OR.

CALL THE MAC EXPERTS!

Your one-stop source for everything Macintosh®. Friendly help and expert advice is our specialty! Call for the absolute lowest prices and immediate delivery on over 30,000 Mac® products!

Produce Commercial-Quality Video!



Filming and editing commercial-quality video has never been easier! Just add a Canon camera (many models available), a 21" Apple Display®, Final Cut Pro software, FireWire cables and expert advice from your PowerMax consultant, and you're set to produce video like you never thought possible!

Only **\$3,599 or just \$137 per month!**

MITSUBISHI DISPLAY PRODUCTS
Innovation On Display.

Model DS50 15" 28mm Display\$215
Model 900u 19" 25mm USB Display\$749
Model LCD80 18" LCD Panel\$3288

TradeUp
with
PowerMax!

The Northwest's largest Mac-only reseller!

We'll take your Mac OS computer in trade toward the purchase of any product we sell! Call one of our expert Mac consultants for full details!

PowerMax Hard Drives

PowerMax Hard Drives contain only top-quality cables, power supplies and internal mechanisms. Satisfaction guaranteed or your money back!*

1.2 GB EXTERNAL APPLE QUANTUM\$149
2 GB EXTERNAL 7200 RPM SEAGATE\$269
9 GB EXTERNAL 7200 RPM SEAGATE\$388



10 GB USB Drive only \$299!

Software Blowouts!

Adobe Photoshop 5.0
Only **\$288!**
Full Retail Office 98
Only **\$299!**

And even more fabulous specials:
External CD-ROM Drive\$39
Conflict Catcher 8.0\$69
Norton Utilities 4.0\$75
Newton MessagePad\$99
Internal 56k G3 Modem\$99
WarCraft II Game\$12
ATI Xclaim TV Tuner\$59
JackHammer F/W SCSI\$99
Iomega 250 Mb Zip Drive\$179

These are only the tip of the iceberg! Call for great deals, expert advice and unparalleled service on Everything Mac. PowerMax: where real people always answer the phone!

Complete System Specialists!

- Professionally bench-tested Macs at low, low pricing.
- Sensational warranties - buy with confidence!
- Wide selection of G3 upgradable models - our Mac experts will go over every detail with you!
- With used and refurbished Macs you get: better expansion, price/performance and upgradability!
- Most non-G3 Macs are fully G3 upgradable!
- Huge selection with new models available every day!

Just a few of the pre-owned and refurbished Macs we have as of press time. See our web site for complete descriptions and the latest list!

6100/60 16/250	\$249	Bondi iMac G3-233 32/4	SCall!
7100/80 AV 24/700	\$299	Refurbished iMac Blowout!	SCall!
7200/75 8/500	\$349	Pwbk G3-233 32/2 14.1"	\$1669
PowerCurve 24/800/CD	\$349	G3-300 Yosemite 64/6	\$1349
7200/90 8/500	\$369	G3-266 Plat 128/4 Gb UW	\$1499
Pwbk 5300C/100 24/750	\$499	G3-266 Plat 64/4 Gb/Zip	\$1499
5260/100 16/1.6 all-in-1	\$499	G3-300 DT 32/4/DVD	\$1649
4400/200 32/2 Gb	\$539	G3-300 Plat 64/4 gb UW	\$1688
7600/120 16/1 Gb	\$639	Pwbk G3-300 64/8/DVD	\$2588
8500/132 16/1 Gb	\$649		
9500/233 32/4 Gb	SCall!		

PowerMax Trinitron® Blowout!

20" **\$488!**
17" **\$349!**

Now for a limited time only, buy the highest quality displays possible at huge, huge savings! The PLUS 17 features a 75hz .25mm Trinitron® tube with a maximum resolution of 1600x1280. This is simply the best-looking 17" display we've ever sold! The 20" display features a .30mm tube also made with Sony's legendary quality - we bought up huge volumes of both models and are passing the savings on to you! Complete with Mac-ready cables and adapters, a five year warranty and our satisfaction guarantee: If the monitor is not just right, we'll replace it for you!

POWER MAX

Knowledge is Power

800-613-2072

Local: (503) 624-1827 • Fax (503) 624-1635
email: sales@powermax.com

Prices subject to change without notice. Prices reflect cash discount. Credit card orders strictly verified against fraudulent use. With use of credit card as payment customer acknowledges that some products are subject to final sale. Many prices are limited to stock on hand. All brand or product names are registered trademarks of their respective holders. * Some restrictions apply. † During business hours. Even experts have to get some sleep!



Apple Studio Displays
17" **\$398!**
21" **\$1129!**



AppleDesign Stereo Speakers
Only **\$49!**



4x4x16 Yamaha CD-R Drive
Only **\$349!**



Wacom 6x8 ArtZ II ADB Tablet
Only **\$169!**



Epson Stylus 3000
Only **\$888!**

Pen Partner 4x5 only **\$59!**
Factory refurbished to new specifications

Visit WWW.POWERMAX.COM
For the very best deals on all the latest Mac equipment!



Authorized Reseller

We accept educational and corporate purchase orders and are experts in financing for virtually any size business!





1-800-533-9005

We are open Mon-Sat, 9am-6pm

Fax Bids: (310) 475-7744 or email at SALES@COMPU-AMERICA.COM
10435 Santa Monica Blvd., Los Angeles, CA 90025

Check out our Web!
WWW.COMPU-AMERICA.COM

Government, University and Fortune 1000 P.O.'s are welcome!
Business Leasing is Available!
International Orders Please call tel: (310) 446-1771

POWERMACS!

- G3/450MT ... 128/9G/24XCD 2649
- G3/400MT ... 128/12G/24XCD/ZIP ... 2199
- G3/400MT ... 64/6G/DVD 1769
- G3/350MT ... 64/6G/24XCD 1399
- G3/400MT ... 128/9G/24XCD CALL
- G3/350MT ... 128/12G/24XCD/ZIP ... CALL
- G3/350MT ... 64/6G/DVD CALL
- G3/300MT ... 64/6G/24XCD CALL
- G3/333MT ... 128/9G/24X CALL
- G3/300MT ... 64/4G/24XCD CALL
- G3/266MT ... 128/4G/24X 1599*
- G3/266MT ... 32/6G/24XCD/ZIP 1499*
- G3/266MT ... 32/4G/24XCD 1399*
- G3/233MT ... 32/4G/24X/MODEM 1299*
- G3/300MT ... 32/4G/24XCD/MODEM CALL
- 9600/350 ... 64/4G/24XCD/ZIP CALL
- 9600/300 ... 64/4G/24X/ZIP CALL
- 9600/200 ... 32/4G/24XCD CALL
- 6500/300 ... 32/4G/24X/CD/FAX CALL
- 6500/250 ... 32/4G/24X/CD/FAX CALL
- 4400/200 ... 32/2G/24X/CD/DOS CARD 899

WORKGROUP SERVERS

- G3/400 ... 256/2-9G/24X/SHARE CALL
- G3/350 ... 128-9G/24X/SHARE CALL
- G3/333 ... 128/2-9G/24X/SHARE CALL
- G3/266 ... 128/4G/24X/SHARE 1599

I-MACS
Starting at \$899

- I-MAC G3/233 32/4G/24XCD/56K 899
- I-MAC G3/266 32/6G/24XCD/56K/BLUDB 999
- I-MAC G3/266 32/6G/24XCD/56K/LIME 999
- I-MAC G3/266 32/6G/24XCD/56K/STRAW 1099
- I-MAC G3/333 32/6G/24XCD/56K 1099

NEW G3 POWERBOOK!

- G3/233 ... 32/2G/20X/12.1STN/56K CALL
- G3/250 ... 32/4G/20X/13.3FT/56K CALL
- G3/233 ... 32/2G/20X/14.1TFT/56K CALL
- G3/266 ... 64/4G/20X/14.1TFT/56K CALL
- G3/300 ... 64/8G/20X/14.1TFT/56K CALL
- G3/300 ... 64/8G/DVD/14.1TFT/56K 2279
- G3/333(NEW)64/4G/24X/14.1TFT/56K/3149
- G3/400(NEW) 64/6G/DVD/14.1TFT/56K/3149

POWERBOOKS
Starting at \$599

- 3400C/240 ... 16/3G/CD/1600 1299*
- 3400C/200 ... 16/2G/CD/1600 1199*
- 3400C/180 ... 16/1G/CD/1600 1099*
- 2400C/180 ... 16/2G/CD 1199*
- 1400C/166 ... 16/2G/CD 1099*
- 1400CS/166 ... 16/2G/CD 999*
- 1400C/133 ... 16/1G/CD 999*
- 1400CS/133 ... 16/1G/CD 999*
- 5300CE/117 ... 16/1G/14.4MODEM 599*
- 5300CS/100 ... 8/500 499*

ViewSonic®
Starting at \$134

- Q41 14" 129
- Q51/Q33 15" 159/169
- Q71/Q100 229/549
- E771 239
- V73/V75 17" 319/379
- V95/V115 499/649
- G771/G773 329/349
- G775/G790 479/499
- P775/P775/P771 499/549/549
- H810/P810 799/899
- P817 1199
- VIEWSONIC WWPAN VPA138 CALL
- VIEWSONIC WWPAN VPA 143 749
- VIEWSONIC WWPAN VPA 150 CALL
- VIEWSONIC WWPAN VPA 180 18" 2499

SONY
Starting at \$199

- Sony 1106S/210US 199/369
- Sony 220G5/420G5/520G5 399/599/899
- Sony 200PS/400PS/500PS 499/699/999
- Sony F-400/F-500 CALL
- Sony L-150 CALL
- Sony PRESANTION W7000/W9000 CALL
- Sony MAVICA F051/F071/F091 469/649/899

EPSON®
Starting at \$199

- STYLUS COLOR 700/850 229/239
- STYLUS COLOR 740/740/750 229/259/279
- STYLUS COLOR Photo-1200 CALL
- STYLUS PRO-XL 199*
- STYLUS COLOR 1520 449
- STYLUS COLOR 3000 799*/1099
- EXPRESSION/636/ART CALL
- EXPRESSION/636/PRO CALL
- 4000N/4000TN 1099/1199
- 2100M/2100TN 729/899
- GMP 649*

UMAX®
Starting at \$99

- VISTA Astra 610S-P 99
- VISTA Astra 1200/1220 149/159
- VISTA Astra 2000U USB 129
- VISTA Astra 2400S 299
- POWERLOOK II 779

Intuos
Starting at \$99

- INTUOS 4 X 5 (USB) 99
- INTUOS 6 X 8 299
- INTUOS 9 X 12 399
- INTUOS 12 X 12 CALL

ioemega
Starting at \$79

- ZIP DRIVE 100 MB EXT (SCSI) 99
- ZIP DRIVE 100 MB INT(G-3) 99
- ZIP DRIVE 100 MB EXT (USB) 119
- JAZZ DRIVE 2 GIG EXT/INT 299/299
- ZIP 100MB CART (10 PACK) 85
- JAZZ CART 1 GIG 79
- JAZZ CART 2 GIG 79

YOUR #1 COMPUTER SUPERSTORE!

All prices are cash discounted. ** denotes a refurbished product. Not responsible for typos. Apple, the Apple logo, GeoPort, HyperCard, ImageWriter, LaserWriter, Mac, Mac OS logo, Macintosh, MessagePad, Newton, OpenDoc, PowerMacintosh, PowerBook, QuickTake, QuickTime, QuickTime logo and StyleWriter are trademarks of Apple Computer, Inc., registered in the U.S. and other countries. All other names & logos are trademarked by their respective owners. We are Not Apple Authorized.

voice: 925-689-9488 fax: 925-689-9487 PRICES & QUANTITIES SUBJECT TO CHANGE Place Your Orders OnLine!

www.macresq.com • MacResQ • 1-888-447-3728

Toll Free

Apple CPU'S

- PM 6100's...from \$99
- Perf. 6200/75's...\$299
- PM 7200/120's...\$399
- PM 8500/120's...\$799
- PM 9500/132's...\$899
- BEIGE G3's...from \$999

iMac's
\$899

In Stock !!! G3/266 iMac's
32/6 Gig/24xcd/56k **\$899**

Add'l USB peripherals available: printers, scanners, etc.

Monitors

- Magnavox 14"\$99
- Apple 14" Color Plus.....\$99
- Qume 17" Multi-scan.....\$199
- Apple 1710av.....\$299
- AppleVision 720 (17")\$299
- Apple ColorSync 17"\$399
- SuperMac SuperMatch 21"...\$599

Hard Drives & Apple CD Roms

- Apple 500mb.....\$79
- 1.2 Gig SCSI.....\$99
- 3.2 Gig SCSI.....\$139
- 4.3 Gig SCSI.....\$169
- Apple 2 Gig IDE.....\$199
- 10.2 Gig IDE.....\$199

Software Specials

- Mac OS 8.5.....\$49
- Norton 4.0.....\$29
- Mac OS 7.6 w/ Claris 4.0...\$29
- Mac OS 8.1.....\$29
- ClarisWorks 5.0.....\$29

Floppies & Power Supplies

- Floppies: 661-0474 (auto) \$49
- 661-0121 (manual) \$59
- 661-1651 (PB 100 ser.) \$89
- 661-0994 (PB 500 ser.) \$99
- 661-1390 (G3; 5 volt) \$59

Miscellaneous items

- ixMicro UltimateRez 8mb PCI card...\$89
- GV external 33.6 geoport modem.....\$49
- GV external 56k mod.....\$69

15% re-stocking fee-ALL ITEMS REFURBISHED UNLESS NOTED AS NEWY • All Parts Sold With a 90 Day MacResQ Exchange Warranty • Exch. Required For: SOME Power Supplies • All Major Credit Cards With NO Surcharge • Choose 437 at www.macworld.com/getinfo

Special Savings on Reconditioned Macs from DataTech

POWERMAC 7300
\$699

7300/180
16/2G/CD

POWERMACS*
8100/110 32/2G/CD \$499
9500/132 32/2G/CD \$699
8600/200 32/2G/CD \$899

*All CPUs include mouse

POWERBOOK
\$999

3400c/180
16/1.3G/CD

Add 32MB RAM \$50
Leather Carrying Case \$29

RAM SPECIALS
32MB 168 pin DIMM... \$45
64MB 168 pin DIMM... \$85
32MB for PB 3400 \$50

MONITORS
\$249

AppleVision
1710 Display

21" Radius
PrecisionView \$399
ThunderPower 30/1920
PCI Video Card \$149

* Other products available
* We buy used equipment

TO ORDER CALL
1-800-281-3661

DataTech
REMARKETING, INC.

Tel: 615-860-4422
Fax-On-Demand: 615-860-0109
Fax: 615-860-0390
Web: www.datatech-rmkt.com
471 Myatt Dr., Madison, TN 37115

* 6-month warranty
* VISA & MasterCard accepted

www.PowerBook1.com

Secure Online Ordering!

Your Source for PowerBook
Upgrades, Accessories and Solutions

CapSure Card \$129
Kritter Cam \$239
640x480, 30fps
Video for G3 Series/G3/400/2400

O'Grady's Macworld Best of Show Pick
MadsonLine AC Adapter
Half the size/weight of Apple's 1400 adapter!
only \$85
Madsonline Auto Adapter only \$65
w/Airline Plug only \$80

VST PRODUCTS
Zip Drives & Power Accessories
PB 1400 Zip \$199
PB 3400, G3, 5300, 190 Zip \$219
PB G3 Series Zip \$219
PB 3400/G3 Li-Ion Battery w/Charger \$269
PB G3 Series Li-Ion Battery w/Charger \$269

MCE MobileStor
High Capacity PowerBook Drive Solutions
For use in PB G3 Series, G3, 3400, 2400, 1400, 5300, 190, 150 & Duo 2300
MobileStor 4300T **4.3GB** TOSHIBA, 3 yr wty **\$179**
MobileStor 4300I **4.3GB** IBM, 3 yr wty **\$199**
MobileStor 6400T **6.4GB** TOSHIBA, 3 yr wty **\$249**
MobileStor 6400I **6.4GB** IBM, 3 yr wty **\$279**
MobileStor 10Gt **10GB** TOSHIBA, 3 yr wty **\$449**
MobileStor 14Gt **14GB** IBM, 3 yr wty **\$649**
For use in PB 500 Series, Duo 2XX Series, and PB 140 through 180c (except 150)
MobileStar 4300SCSI **4.3GB** 2 yr wty **\$349**
MobileStar 6400SCSI **6.4GB** 2 yr wty **\$429**

MCE Xcaret
Media Bay Hard Drives
for PB G3 original, 3400, 5300, 190; Xcaret Pro for PB G3 Series
10GB **\$599** 6GB **\$399** 4GB **\$329** 0GB kit **\$149**

DATA SHUTTLE
PC Card Hard Drives
• Hot swappable • Powered by PC Card
10GB **\$549** 4GB **\$299** 0GB kit **\$129**

VRATOC Systems
CBFW2 FireWire CardBus PC Card **\$279**
VST 14GB FireWire Hard Drive \$please call
Call for other great FireWire
and USB products for your PB!

Highest Quality Only! **MEMORY** Call for latest pricing!
Viking Components
PB G3 Series **64MB** **\$149** **128MB** **\$239**
PB G3 Original **\$159** **\$269**
PB 3400 **\$159** **\$269**
PB 2400 **\$149**
48MB module for PB 1400 \$189
Pricing may vary

MCE ADD FlexLight
FREE
weevey order over \$300,
or \$29 separately

Lights up your PowerBook!
Plugs into ADB Port.

WOW!!!
SCSI
4 & 6GB!!

GREAT!!
MobileStor
drives
come with
everything
I need for
installation!

Included FREE with every MCE
MobileStor hard drive solution is
the complete MCE PowerBook
Hard Drive Installation Kit
which includes an installation manual, and all
of the tools and appropriate brackets needed
for the proper installation of your new drive.

Hot Swappable!

Digital Video!

VRATOC Systems

Your #1 Source for Complete PowerBook Storage Solutions!

30 Hughes Suite 203 • Irvine, CA • 92618
Visa / MC / AmEx / Discover / P.O.'s

1-800-5000-MAC • 949-458-0800 • fax 949-458-1803

Choose 439 at www.macworld.com/getinfo

Infinity Micro

800-589-1234

\$1295.* **\$849.*** <http://www.infinity-micro.com>
Email us at: Sales@infinity-micro.com
Int. (310) 470-9426 Fax: (310) 470-4956
2289 Westwood Blvd. Los Angeles, CA, 90064

<p>PowerMacs</p> <p>G3/450 128/500/CD "NEW" 2695 G3/400 128/12G/CD/ZIP "NEW" 2249 G3/400 64/8GB/DVD "NEW" 1795 G3/350 64/8GB/CD "NEW" 1429 iMAC G3/233 32/4GB/24X/15" 849 iMAC G3/266 4/3/333 1095/1195 G3/233 32/4GB/24X/CD/15" BLTIN" 1295 G3/266DT 32/4GI/24XCD* 1195 G3/266DT 32/2GI/24XCD* 1995 G3/333MT 129/9GI/24XCD* 2295 G3/300MT 64/8GB/CD 1295 G3/350MT 64/8GB/DVD 1295 G3/350MT 128/12G/CD/ZIP 2095 G3/400MT 128/9GB/CD 2495 9600/350 64/4GI/24xCD/Zip 2495 8600/300 32/4GB/24xCD* CALL 7300/200 32/2GI/24XCD* CALL 7100/80 8/500/CD 895 6500/300 32/4GB/12XCD/56K/ZIP 249 6500/275 32/6GB/24XCD/56K/ZIP 995 4400/200 32/2GB/CD/DOS 895 5500/225 32/2GB/12x/15" 695 7200/90 24/500/8xCD 995 7200/120 32/1.2/8xCD* 249</p> <p>APPLE PRINTERS</p> <p>ColorStylewriter 4500* 199 LaserWriter 12/6/40* 1995 LaserWriter Color 12/660 795 LaserWriter 8500 1095</p> <p>DIGITAL CAMERA'S</p> <p>SONY MAVICA FD91/FD73 905/472 SONY MAVICA FD88/FD71 847/631 AGFA EPHOTO 1680 576 AGFA EPHOTO SMILE DIGITAL C 127 AGFA EPHOTO CL30/CL50 364/659 AGFA EPHOTO 780C 183</p>	<p>POWERBOOKS</p> <p>G3/400 64/8GB/DVD/56K/14.1" 3295 G3/333 64/4GB/24X/56K/14.1" 2395 G3/300 64/8GB/CD/56K/14.1" 2495 G3/300 64/8GB/DVD/56K/14.1" 2995 G3/292 64/8GB/20X/56K/14.1" 2495 G3/250 64/4GB/20X/56K/14.1" 1995 G3/233 32/2GB/20X/56K/13" 1495 G3/233 32/2GB/20X/56K/14.1" 1595 G3/233 32/2GB/20X/CD/13.3" 1495 G3/233 32/2GB/20X/56K/12.1" 1295 G3/233 32/2GB/20X/12.1" 1195 3400C/240 16/3GB/12XCD 1395 3400C/200 16/2GB/12xCD 1295 3400C/180 16/1.3GB/8XCD* 1295 1400C/133 16/1.3GB/8XCD* 1195 5300C 16/1GI/6 595 5300CS 16/750 445 2400C/180 16/1.3GI/6 695 540C 32/500/19.2MDM 1195 180 14/120/14.4 Fax* 595 Apple Duo Dock iPLUS 275</p> <p>PRINCETON</p> <p>E0400/DP5500/APP560 154/818/1015 E0505/ULTRA52B/95 167/176/418 E0505/ULTRA 52/75B 167/155/255 E0500/DP5500/550 182/949/938 E0750/E0705/AGX750 391/241/405 E0720/E0710/E0705 303/293/241 E0700/E0930/E0900 279/485/475</p> <p>APPLE MONITORS</p> <p>Apple Studio Display 17"/21" 475/1395 Apple Studio Display 15" 1095 212 APPLE ColorSync 17"/20" 395/795* APPLE 15" AV/1705/1710 185/249* Apple 20" Multi-Res/AV 595*</p> <p>EPSON STYLUS COLOR PRO-XL 11x17 \$199.97 Postscript option only \$ 229.</p> <p>TRADE IN YOUR MAC TOWARDS A NEW ONE! WE WILL BEAT YOUR BEST PRICE!</p>	<p>HP</p> <p>LaserJet 6MP/4MV 597/597 LaserJet 55IMM 1397 LaserJet 2100M/2100TN 737/927 LaserJet 4000/4000TN 847/1297 LaserJet 4050N/4000T 1297/1237 LaserJet 4050I/5000 1227/1387 LaserJet 5000N 1847 LaserJet 5000GN 2079 LaserJet 8000 1877 LaserJet 8000DN 2989 LaserJet 8000N 2277 LaserJet 8100 2497 LaserJet 8100DN 3347 LaserJet 8100X 2827</p> <p>GCC TECHNOLOGIES</p> <p>Elite 12/600/1212 799/947 Elite XL-608LC 1029 Elite XL-1208 2395 Elite XL-20/1200 1995 Elite XL-20/600 1495 Elite XL-20/800 1795</p> <p>EPSON</p> <p>Epson Stylus 500/1520 Call/449 Epson Stylus 3000 1095/789* Epson Stylus 740/740I 239/269 Epson Stylus 850/850NE 269/449 Epson Stylus Pro-XL 11x17 199 Epson Stylus 900/900N 409/609 Photo 1200/700/750 474/237/289 BOCA/GLOBAL VILLAGE</p> <p>TELEPORT 56K USB Mac 119 TELEPORT 56K V90 G3/MAC 99 POWERPORT 56K PC/MCIA 149 19.2 FAX MDM/PB-500 Series 39</p> <p>AGFA</p> <p>DuoScan SOLO/DuoScan 11200 2249/559 Snapscan 1212U/1236S 116/159 SnapScan 1236/800 Call SnapScan Touch USB 117</p> <p>EPSON</p> <p>Expression 800 ART/EXE/PRO 679/589/899 Expression 636XL 2099 Perfection 636/636U 259/199</p> <p>MICROTEK</p> <p>Scanmaker 35T PLUS 499 ScanMaker 4FL 4/IG3 609/619 ScanMaker 5 DUAL PSLE 2169 Scanmaker 6400XL DUAL 898 Scanmaker 9600XL 1299 ScanMaker X6/X6USB/X6EL 136/135/209</p> <p>UMAX</p> <p>Astra 610s/1200S/1220U 59/118/119 Astra 2000U/2100U 118/149 Astra 1220S/2400S 128/279 Mirage II/ISE PHT./ISE 1699/1079/799 PowerLook 3000/1A/D 5895/949 PowerLook II/SE/II CALL/565</p> <p>SONY</p> <p>SONY 100ES/100GS 165/199 SONY 110GS/420GS 189/589 SONY 200ES/200GS 309/549 SONY 200PS/400PS 549/689 SONY 500PS/220GS 1069/1409 SONY 520GS/120VS 959/309 SONY GDM-V900 24" 1999 SONY F400 19"/F500 21" 949/1689</p> <p>BATTERY</p> <p>Battery for PB-G3 or 5300 series 39. PowerBook 180 11/120/14.4 295 PowerBook 520C 12/240/19.2 395 PowerBook 540C 16/500/19.2 495 PowerBook 500 Series Battery 49 PowerBook 500 Series 8MB Mem. 29 PowerBook 500 Series battery 189 Magnavox 20" Color 395 Epson Stylus ProXL 249 Farallon Etherwave Adapter card 29 Cyrex Pentium 100MHz PC card 49 Radius full page monitor 499 Radius 20" Intellicolor 499 RasterOps 20" Black & white 195 ViewSonic 6910 monitor 695 Portrait Pivot Display 17" 295 Apple Ext. Video connector 49 Performa 640 12/500/CD 195 Apple Laser 16/600 220V/10s 995 Mainclosser Centris Nubus Adap. card 19</p> <p>SOFTWARE</p> <p>Adobe Photoshop ver. 5.0.2 MAC 577 Adobe Illustrator ver. 8.0 MAC 358 Adobe PageMaker PLUS ver. 6.5.2 512 Adobe After Effects V.4.0 STD/PRO 599/1295 Quark Express Ver. 4.0 MAC 789 Microsoft Office 98 POWERMAC 427 Microsoft Office GOLD POWERMAC 513</p> <p>RASTEROPS</p> <p>SuperScan MC6415/MC6405 399/277 SuperScan MC6215/MC7515 387/537 SuperScan MC8115/MC801HR 887/697</p> <p>PHILIPS/MAGNAVOX 4 YEAR ON SITE WARRANTY!</p>
--	--	---

*Prices are cash discounts/Subject to change with notice/Visa/MC/AmEx/Discover & Corporate P.O.'s welcome. *Factory recommended prices

Choose 440 at www.macworld.com/getinfo

Systems & Peripherals Memory & Upgrades

Macworld SHOPPER

SERVING MAC USERS SINCE 1987

MacBYTE
Authorized Dealer

GREAT DEALS ON USED MACS NOW!

PC100	for Blue & White Yosemite G3	64 mb \$ 50	128 mb \$ 90
SDRAM	for Beige Desktop & MiniTower G3	64 mb \$ 50	128 mb \$ 90
iMac RAM		64 mb \$ 53	128 mb \$ 98

www.computeraddict.com
800-432-2983
1024 Harding Ave., #203, Venice, CA
Fax: 310/448-4494

**USED MACS & POWERBOOKS
WANTED!**

WE BUY USED MACS!

TOP \$\$\$ PAID

Any Quantity
FedEx check delivery
Fax a list for a quote
310 966-4433

MAC Solutions
11933 Wilshire Blvd.
W. Los Angeles, CA 90025
sales@macsolutions.com
(800)80-WE-BUY

MEMORY

The Best Memory Prices & Guarantee

800-662-7466

Secure online ordering: datamem.com
Lifetime Memory Replacement Guarantee
DMS will meet or beat anyone's price!

newer technology

UMAX
LACIE

EPSON

USB **USB** **USB**

Pentium® Computer System Specials

USB Scanners/Printers & Accessories

• Accelerators & CPU Upgrades
• Hard Drives & CD-ROM Drives
• Modems for Mac & PCs
• Monitors-Std. color to Pro Mods.
• UMAX Color Scanners
• EPSON Stylus Color Printers
• Networking Connection Prods.

HAWKE SYSTEMS
2550-A Chimney Rock Rd
Hendersonville, NC 28792
(800) 875-2610

Specialist in Refurbished
Macintosh Computer Equipment
Complete Color Packages
Apple 13" HiRes Color Monitor
Starting at \$49.00
Hard to Find Service Parts
for Mature Mac Equipment
Refeb Floppy Drives \$39.00

Complete list on our Web Site at
www.MacHawke.com

Choose 444 at www.macworld.com/getinfo

Mac Pro Systems & Software
Since 1988

Buy • Sell • Trade • Upgrade • Repair
New • Used • Refurbished

Small Ad Lowest Prices

Any Ad is a Mac Pro Ad
Check out our Wholesale Specials @
www.mac-pro.com

800-525-3888
fax: 408-369-1205

Choose 443 at www.macworld.com/getinfo

DMS DATA MEMORY SYSTEMS

DMS ACCEPTS GOVERNMENT, EDUCATIONAL & CORPORATE PO's WITH PRIOR APPROVAL

FAX P.O.s 24 HOURS TO DMS @ 603.898.6585
Open M-F 9a.m. 'til 9p.m.

MEMORY MADNESS

The LLB Company, Inc.
1-800-848-8967

DIMMs \$105 128MB

POWERMAC G3
PC66-10NS

32MB 4x64.....\$35
64MB 8x64.....\$55

128MB 16x64.....\$105
256MB 32x64.....\$375

\$169 64MB

8x64x60EDO 3.3V

16MB 2x64.....\$49
32MB 4x64.....\$78
64MB 8x64.....\$169

\$110 64MB

8x64x60EDO 5V

16MB 2x64.....\$40
32MB 4x64.....\$55
64MB 8x64.....\$110

DIMMs \$58 64MB

NEW POWERMAC
G3 8X64-8
(PC100-8NS)

64MB 8x64.....\$58

128MB 16x64.....\$113
256MB 32x64.....\$485

\$58 32MB

168-PIN FPM DIMM

32MB 4x64.....\$58
64MB 8x64.....\$105

128MB 16x64.....\$275

SIMMs \$55 32MB

72-PIN SIMM

8MB 2x32.....\$21
16MB 4x32.....\$29
32MB 8x32.....\$55

FROM THE LLB COMPANY

IOMEGA

Zip Drive	'119
Zip Drive USB	'151
ZIP 100 disk	'10
ZIP 100 disks -3-pk	'28
ZIP 100 disks -10-pk	'89
Jaz 1GB disk	'89
Jaz 1GB disks - 5-pk	'405
Jaz 1GB disks - 20-pk	'1524

NEWER TECHNOLOGY

For the PowerMac 6100 Series

Maxpower G3 240/266MHz/1MB Cache	'397
NEW For the PowerMac 7500/8500/ Etc.	
Maxpower G3 306MHz/1MB Cache	'617
Maxpower G3 400MHz/1MB Cache	'726

NEW For the PowerMac G3 Series

Maxpower G3 366MHz/1MB Cache	'615
Maxpower G3 400MHz/1MB Cache	'679
Maxpower G3 466MHz/1MB Cache	'617

Powerbook

WALL ST./IMAC	PB DUO SERIES	PB 500 SERIES	PB3400 G3
128MB '115	36MB *call	32MB '120	128MB '235
64MB '55	28MB *call	16MB '62	64MB '160
32MB '34	20MB *call	8MB '45	32MB '94
16MB '29	14MB *call	4MB '40	16MB '83

DESKTOP/MINITOWER

IMAC 233 32/4GB/24X CD/56k	'999
IMAC 333 32/6GB/24X CD/56K	'1179
G3/300 (MT) 64/6GB/24X CD	'1537
G3/350 (MT) 64/6GB/DVD	'1976
G3/400 (MT) 128/9GB/24X	'2882

POWERBOOKS

G3/333 64/4GB/20X14.1 TFT	'2424
G3/400 64/8GB/20X14.1 TFT	'3399
G3/266 64/2GB/20X14.1 TFT	'2200
G3/300 64/8GB/20X/14.1 TFT	'2999

WALL ST./IMAC

PB 3400 SERIES	PB 5300 SERIES	PB1400 SERIES	PB 2400 SERIES
128MB '235	48MB '189	48MB Kit '189	64MB '135
96MB '180	32MB '133	24MB '102	32MB '95
64MB '164	16MB '60	16MB '69	24MB '85
32MB '68	8MB '55	8MB '52	16MB '75

www.llb.com International:425.881.1880 Fax:425.881.1930

COMPARE OUR LOW SHIPPING RATES
E-Mail: sales@llb.com
PO's accepted upon approval
No surcharge on credit cards
• Returns subject to restocking fee
• Prices subject to change, not responsible for errors
• International orders welcome
Mail PO's to:
2513 152nd Avenue N.E.
Redmond, WA 98052

Choose 442 at www.macworld.com/getinfo

AWARD-WINNING UPGRADES!

G3

SONNET™
SIMPLY FAST™



**G3 for PCI
as low as
\$249⁹⁵**

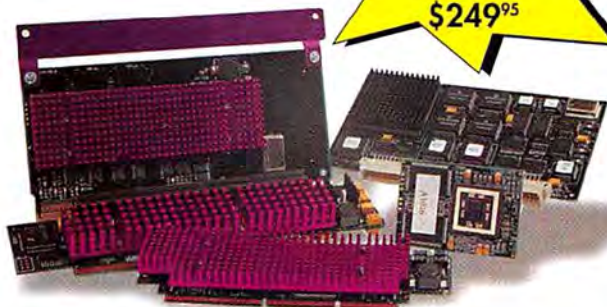

Sonnet™ Technologies manufactures the finest Macintosh processor upgrade cards for a wide range of computers including 68040, NuBus, PCI, and G3 Power Macs.

- Match or beat the CPU performance of a new G3 system.
- 100% software compatible.
- Plug-and-play installation.
- No switches or control panels to set.
- Backed by a three-year warranty.

We now have video card support for the 6100AV. If you have a 7100 or 8100 with a video card in the PDS slot just install one of our 7100 or 8100 Adapter Kits. Or install a Sonata Pro 24 for comparable or superior performance to the Apple PDS AV and High Performance Video Cards.

Other PCI Power Macs (upgrade-challenged) can now be upgraded through the Level 2 (L2) cache slot.

Got a Quadra or Centris? You can now run Mac OS 8.5 and realize all the performance of PowerPC native applications.

CRESCENDO G3 CARDS FOR NUBUS MACS (FITS IN PDS SLOT)

Power Mac 6100/7100/8100/8115 • Wrkgrp Svrv 6150/8150/9150
Performa 6110/6112/6115/6116/6117/6118 • Power 100/120 • Radius 81/110

Crescendo G3/NuBus 266 MHz/133 MHz/512K Cache	\$299 ⁹⁵
Crescendo G3/NuBus 266 MHz/133 MHz/1MB Cache	\$399 ⁹⁵
Crescendo G3/NuBus 300 MHz/150 MHz/1MB Cache	\$499 ⁹⁵
Crescendo G3/NuBus 400 MHz/200 MHz/1MB Cache (80 & 120 MHz machines only)	\$699 ⁹⁵

Video Options

7100 PDS AV/HPV Video Adapter Kit for Crescendo G3	\$99 ⁹⁵
8100 PDS AV/HPV Video Adapter Kit for Crescendo G3	\$99 ⁹⁵
7100/8100 Sonata Pro 24 NuBus Video Card	\$199 ⁹⁵

CRESCENDO G3 CARDS FOR PCI MACS (FITS IN PROCESSOR SLOT)

Power Mac 7300/7500/7600/8500/8515/8600/9500/9515/9600
Wrkgrp Svrv 7350/8950/9650 • DayStar Genesis • PowerCenter
PowerCenter Pro • PowerCurve • PowerTower • PowerTower Pro
PowerWave • UMAX J700/S900

Crescendo G3/PCI 250 MHz/125 MHz/512K Cache	\$249 ⁹⁵
Crescendo G3/PCI 300 MHz/150 MHz/512K Cache	\$299 ⁹⁵
Crescendo G3/PCI 300 MHz/150 MHz/1MB Cache	\$499 ⁹⁵
Crescendo G3/PCI 333 MHz/166 MHz/1MB Cache	\$549 ⁹⁵
Crescendo G3/PCI 400 MHz/200 MHz/1MB Cache	\$699 ⁹⁵
Crescendo G3/PCI 466 MHz/233 MHz/1MB Cache	\$899 ⁹⁵

CRESCENDO G3 UPGRADES FOR "UPGRADE-CHALLENGED" PCI POWER MACS (FITS IN L2 CACHE SLOT)

POWER MAC 54/55/6500 • PERFORMA 5400/6360/64XX •
ZOTHI AMNY: MAC • POWERBASE DESKTOP

Crescendo G3/L2 250/125 MHz/512K Cache	\$299 ⁹⁵
Crescendo G3/L2 300/150 MHz/512K Cache	\$399 ⁹⁵
Crescendo G3/L2 300/150 MHz/1MB Cache	\$499 ⁹⁵
Crescendo G3/L2 400/200 MHz/1MB Cache (55/6500, TAM only)	\$699 ⁹⁵

Power Mac 4400 • StarMax 3000/4000

Crescendo G3/L2 240/120 MHz/512K Cache	\$299 ⁹⁵
Crescendo G3/L2 300/150 MHz/512K Cache	\$399 ⁹⁵
Crescendo G3/L2 300/150 MHz/1MB Cache	\$499 ⁹⁵

ENCORE G3 CARDS FOR G3 POWER MACS (FITS IN ZIF SOCKET)

Power Mac G3 All-in-one/Blue & White/Desktop/Tower/Server
Encore G3 466/233 MHz/1 MB Cache

Encore G3 466/233 MHz/1 MB Cache	\$799 ⁹⁵
----------------------------------	---------------------

PRESTO PPC UPGRADES FOR QUADRA & CENTRIS (FITS IN PDS SLOT)

Quadra 700/800/900/950 • Quadra/Centris 610/650
(610 Requires Adapter)

Presto PPC 100 MHz/1MB Cache	\$299 ⁹⁵
Quadra/Centris 610 Adapter	\$49 ⁹⁵

G3 Speeds Up to 900% Faster for Your PCI Power Mac!



Performance results based on MacBench 4.0 processor scores

Run Your NuBus Power Mac at G3 Speeds Up to 1400% Faster!



Performance results based on MacBench 4.0 processor scores

Now Supports 6100 AV!

Sonnet Technologies, Inc.
18004 Sky Park Circle, Irvine, CA 92614-6428
Tel: 949-261-2800 Fax: 949-261-2461
E-mail: sales@sonnettech.com



800-786-6260
<http://www.sonnettech.com>

Visa, MasterCard and American Express no surcharge. Government, corporate and education POs welcome. Sonnet products are covered by a three-year limited warranty. Prices are subject to change without notice. Returns require an authorization and are subject to a restocking fee. Sonnet, the Sonnet logotype, Crescendo, Encore, Presto, and the Simply Fast logotype are trademarks of Sonnet Technologies, Inc. ©1998 Sonnet Technologies, Inc.

MEMORY

WE'LL BEAT ANY PRICE!

Special Web Site Pricing
available only at www.macsolutions.com

ABSOLUTELY, POSITIVELY,
THE BEST PRICES!

Plus, Lifetime Warranty on all RAM!

YOSEMITE - PC 100		iMAC RAM		G3 SDRAM - In Stock!!	
32 mb	\$ 33	32 mb	\$ 30	32 mb	\$ 33
64 mb	52	64 mb	52	64 mb	52
128 mb	99	128 mb	104	128 mb	99
256 mb	437	256 mb	428	256 mb	237
PowerBook G3 (98-99)		168 Pin DIMMs		SIMMs 72 & 30 pin	
32 mb	\$ 30	16 mb	\$ 25	4 mb	30 pin \$ 8
64 mb	52	32 mb	48	16 mb	30 pin 19
128 mb	104	64 mb	97	16 mb	72 pin 22
256 mb	428	128 mb	205	32 mb	72 pin 44

NEW & PRE-OWNED MACS & POWERBOOKS!

BLAZING FAST NEW MACS* - INSANELY GREAT!

iMac 333 MHz	32/6gb/24x/56k	\$ 1,199
G3 350 Yosemite	64/6gb/32x	1,599
G3 400 Yosemite	64/6gb/DVD	1,999
G3 400 Yosemite	128/12gb/32x/Zip	2,499
G3 450 Yosemite	128/9gb UW/32x	2,999
PB-G3/333TFT/14.1	64/4gb/24x/56k	2,499
PB-G3/400TFT/14.1	64/6gb/DVD/56k	3,499

HARD DRIVES & SPECIALS



IBM 1 gb SCSI	\$ 89
Quantum 1.2 gb SCSI	115
Seagate 4.5 gb Medalist Pro SCSI	195
Seagate 9.1 gb Medalist Pro SCSI	345
Quantum 9.1 gb ATLAS IV Wide SCSI	365
Seagate 9.1 gb Barracuda Wide SCSI	369
Seagate 9.1 gb Cheetah Wide SCSI	535
Quantum 18.1 gb ATLAS IV Wide SCSI	699
Seagate 18.1 gb Barracuda Wide SCSI	719
Seagate 18.1 gb Cheetah Wide SCSI	895
IBM 36 gb Wide SCSI	1,150
Quantum 4.3 gb IDE	110
Quantum 6.4 gb IDE	139
IBM 16 gb IDE	215
TEAC 6x24 CD-R with TOAST	315
IDE to USB External Case use those drives!	90
SOFTWARE & PERIPHERAL SPECIALS	
Apple OS X Server	460
Apple Mac OS 8.1 CD only	25
Mac OS 8.6 upgrade with Free 8.5 CD	70
Apple Final Cut Pro	999
Epson 740i color ink jet printer	279
MacAlly iMouse	25
MacAlly iHub	49
MacAlly iBall	49
VST USB Floppy Drive	80



CALL
for the most up-to-date
Apple® product information!

CHECK OUT THESE GREAT DEALS ON USED MACHINES

8600/200	32/2gb/12x	\$ 995
9500/132	16/1gb/4x	800
8500/120	16/1gb/4x	700
6500/250	32/4gb/12x	700
6400/180	16/3.2gb/8x	600
6200/100	8/1gb/4x	300
7100/66	8/230	275
6100/60	8/no drive	225
PwrBook 1400c/117	16/1gb/6x	1,050
PwrBook 1400cs/117	16/750/6x	995
PwrBook 5300c/100	16/500	675

WE BUY, SELL & TRADE MACS!
CALL 800-80-WE-BUY



CALL
for Used G3 Desktop, MiniTower &
PowerBook pricing & availability

Pre-owned machines subject to prior sale. Inventory changes daily, call for availability. *New Apple product available in-store only.

ADAPTEC • ASANTE • EPSON • GLOBAL VILLAGE • IBM • IMATION • IOMEGA • NEWER • QUANTUM • SEAGATE • SONY • UMAX • VST

Apple Authorized Dealer Apple Specialist Apple Authorized Service Provider

(800) 873-3RAM

MacSolutions, Inc. Fax: (310) 966-4433
11933 Wilshire Blvd, West Los Angeles, CA 90025
University & School P.O.'s Welcome.

Secure Online Ordering at

www.macsolutions.com



**MAC
Solutions**

All prices are subject to change. Merchandise subject to prior sale. Please call for up-to-the-minute info and availability. Not responsible for typographic errors. Limited to stock on hand. Ad Code #716

Open Monday-Friday: 9am-8pm & Saturday: 10am-5pm CST E-Mail Us at: owc@macsales.com

Other World Computing

Serving the Mac Universe Since 1988



800-275-4576



Competitive Prices, Quality Products and NEVER a Surcharge for Credit Cards!

www.macsales.com
has Easy, Fast,
Secure Internet
Ordering Now.



It's a Snap to add G3 Power to your PowerMac!



G3 Upgrades for PowerMac 6100/7100/8100/8150/9150/ Radius; Performa 611X Series

SONNET Cresendo Nubus Series from \$295

G3/250mhz 512k - \$295
G3/300mhz 512k - \$389
G3/300mhz 1024k - \$485
NEW! G3/400mhz 1024k - \$679

G3 Upgrades for PowerMac7300/7500/7600/8500/8600/9500/9600s; WGS 7350/8550/8650/9650; PowerCenter/PowerWave/Power Tower; UMax S900/1700

SONNET Cresendo PCI Series from \$245

G3/250mhz 512k - \$245
G3/300mhz 512k - \$299
G3/300mhz 1024k - \$485
G3/400mhz 1024k - \$665
G3/466mhz 1024k - \$875 NEW 10X Technology

G3 Upgrades for PowerMac 4400/5500/6360/6400/6500/ 20th Anniversary Mac; PowerBase; Umax C500/600 StarMax 3000/4000/5000 Series; Most Motorola Clones

SONNET Banker G3 Series from \$285

G3/250mhz 512k - \$285
G3/300mhz 512k - \$385
G3/300mhz 1024k - \$485
G3/400mhz 1024k - \$659



Interex XLR8 ZIF Carrier PCI DaughterCards

XLR8 G3ZIF Carrier w/o Processor \$169
XLR8 G3ZIF Carrier w/Mercury 233mhz 512k 2:1 \$225
XLR8 G3ZIF Carrier w/Mercury 266mhz 512k 2:1 \$269
XLR8 G3ZIF Carrier w/Mercury 300mhz 1024k 2:1 \$335
XLR8 G3ZIF Carr. w/Merc. 350mhz 1024k 2:1 \$399
XLR8 G3ZIF Carrier w/Mercury 400mhz 1024k 2:1 \$567

Go G3 Now and Easily Upgrade to the New G4 ZIF Processors In The Future!

Seagate 2.1gb Barracuda
7200rpm 8ms w/lyr
\$99 int. \$149 ext.

OWC HardDrives Include FWB 3.0 Hard Drive Toolkit and 30mb of free software INSTALLED. External version features platinum case with dual SCSI ports. Push-button SCSI ID AND 40 watt power.

SCSI Hard Drives	int.	ext.
Quantum		
9.1gb Atlas III 7.5ms 5yr.	\$315	\$369
18.2gb Atlas III 7.5ms 5yr.	\$585	\$645
Seagate		
9.1gb Barracuda 7.1ms 5yr.	\$369	\$425
18.2gb Barracuda 7.1ms 5yr.	\$585	\$645
IBM		
4.3gb IBM Apple Rom 8.5ms 1yr.	\$159	\$215
4.5gb UltraStar 9ES 7200rpm 5yr.	\$229	\$285
9.1gb UltraStar 9ES 7200rpm 5yr.	\$335	\$389
18.2gb UltraStar 9ES 7200rpm 5yr.	\$599	\$659

Visit www.macsales.com for a full selection of UltraWide and Ultra2 drives up to 50gb in a single device!

IDE Hard Drives

SAVE BIG! 4.3gb Seagate Only: \$99

IBM	Seagate	Quantum
13.5 - \$235	6.4gb - \$119	6.4gb - \$145
16.8 - \$319	13gb - \$165	8.4gb - \$165
25.0 - \$355	17.2gb - \$199	13.0gb - \$245

20.4gb Maxtor Only \$335 Call for full lines!

IDE PowerBook Hard Drives
for PowerBook 150, 190/1400/5300/3400; G3 PowerBooks; Duo 2300 and 2400 Series. 4200rpm with 3 year warranty

810Mb IBM Sonata Slim	\$85
4.3gb Toshiba Slim	\$139
6.4gb Toshiba Slim	\$199
6.4gb IBM Slim	\$229
8.1gb IBM Slim	\$319
10.1gb Toshiba Slim	\$329
14gb IBM Non-Slim	\$499

Norton Utilities 4.0 AND Norton AntiVirus 5.0 COMBO ONLY \$49

or Each Available Separately for only \$27.50

ixMicro Ultimate Rez 128 PCI

Video Card SPECIAL! \$75

With 8mb of V-Ram NEW WITH 5 YEAR WARRANTY

Removable SCSI Drives

	Bare	Internal	External
lomega Zip 100 SCSI	\$79	\$99	\$99
lomega Zip 250 Plus			\$175
lomega Jaz 2gb SCSI	\$319	\$329	\$329

Zip 100mb Carts - \$9 each / \$85 per 10
Jaz 1gb Carts - \$79 Jaz 2gb Carts - \$85

Panasonic 4x8 CDR	\$209	\$279	\$309
Yamaha CDRW 4x4x16	\$249	\$309	\$359

CDR & CDRW Internal and External Drives Include Toast Software and Media
CDR 74 Minute Silver Media w/Jewel Case - 10 for \$15 / 50 for \$69.95 / 100 for \$129

www.fastermacs.com

- More Stuff to Make your Mac a FasterMac!
- Upgrades for Older Macs too!

www.macsales.com

- More Mac products and information
- **FREE DELIVERY*** when you place your order online!

Visit us for USB, Monitors, Printers, USED Deals & More....

Mac Memory

72 Pin Simms

16mb - \$29	32mb - \$49	64mb - \$99*
-------------	-------------	--------------

*for 6171/8100 and compatibles only.

168 Pin Dimms	5V	5V Edo	3.3V Edo
16mb	\$36	\$36	\$49
32mb	\$55	\$57	\$95
64mb	\$99	\$99	\$189
128mb	\$239	\$259	N/A

SDRAMs Apple Spec PC100 Memory for ALL Beige G3 Desktops, Minitowers, All-In Ones, & New Blue & White G3 Computers (work with PC's too)

32mb - \$35	64mb - \$59	128mb - \$115
256mb(66mhz) \$319	256mb(100mhz) \$425	

WallStreet & Lombard / iMac (All Speeds)

32mb - \$35
64mb - \$59
128mb - \$115
256mb - \$455

Call or visit www.macsales.com for V-Ram and Video Card upgrades.

OWC is a Techworks Authorized Reseller. Call or Visit our website at www.macsales.com for the best prices on Techworks Grand Memory.

Prices, Specifications and Availability subject to change without notice. Items advertised with 30 day Money Back may be returned complete within 30 days for a full merchandise refund, other items may be returned within 30 days with 15% restocking fee. No returns without Return Merchandise Authorization number.
*Free delivery only available for destinations within the 48 continental United States. WD1099

224 West Judd St., Woodstock, IL 60098 Int: (815) 338-8685 Fax: (815) 338-4332

Memory & Upgrades

Services Data Recovery • Digital Production • Printing • Repair

Macworld

SHOPPER

MEMORY SPECIALISTS



Serving the Mac Users memory needs since 1991. We sell only NEW, Grade A, Full Apple Spec RAM

800-307-3434

Fax 775-823-2200
5301 Longley Lane, Reno, NV 89511
www.tahoeperipherals.com

Choose 448 at www.macworld.com/getinfo

MEMORY BUY/SELL/TRADE

Lowest Prices - Lifetime Warranty



Secure ON-LINE ordering up to **10% OFF**
Website Promo's/Discounts/Free Gifts

800-718-7755

www.MEMORYLIQUIDATORS.com

22825 Lockness Ave., Torrance, CA 90501
310-326-5656 • Fax 310-326-7790
E-mail: sales@memoryliquidators.com

Choose 447 at www.macworld.com/getinfo

Digital Imaging

Slides & Negatives \$3.75
4x5 Chromes/Negs \$30
Large Posters & Displays \$45
Scanning: Hi & Lo Res
Photo CD Scans & LVT Output
Short Run 1200 dpi Color Output
Quantity Prints, Slides, Overheads

Show & Tell 39 W 38th St., NY, NY 10018
212 840-2912 • 212-840-7953 (fax)

Choose 449 at www.macworld.com/getinfo

BIG POSTERS & HUGE DISCOUNTS

FROM YOUR COMPUTER FILES

24" x 36" Full color print on 7 mil high or low gloss paper \$25
36" x 48" Full color print on 7 mil high or low gloss paper \$50
48" x 72" Full color print on 7 mil high or low gloss paper \$125

FOR MORE INFO & PRICING VISIT OUR WEBSITE
www.BIGPOSTERS.com
CREATIVE JIGS PRINTING & GRAPHICS INC.
(New York) Tel: 516-520-4533 Fax: 516-520-4534 • 24 Union Rd., Levittown, NY 11756
1-888-880-HUGE

Choose 452 at www.macworld.com/getinfo

WHY IS THE COMPETITION SHAKING?

BECAUSE
1-800-4-MEMORY
IS HERE

WE CAN BEAT

ANY QUOTED PRICE ON ANY MEMORY FOR ANY COMPUTER (NOTEBOOK, DESKTOP, PRINTERS) ANYWHERE... PERIOD!

- LIFETIME WARRANTY
- FREE TECH SUPPORT
- NO CREDIT CARD SURCHARGE
- MOST ORDERS SHIPPED SAME DAY

CALL AROUND THEN CALL US

CHECK OUR WEB SITE FOR SPECIALS
WWW.18004MEMORY.COM



www.imagers.com
Free Shipping...Call for details

Send PC/Mac files by FTP or Priority Air Express to Imagers and for most output services, your finished work is in your hands the very next morning.

- Digital Short-Run Printing
- Photo CD Film Scanning
- Digital Posters & Banners
- Fuji Digital Photo Prints
- Slides & Overheads
- New Media Services
- Prepress Support Team!



We guarantee our work!
1575 Northside Dr. Ste. 490 Atlanta 30318

800.672.7029/404.351.5800

Choose 451 at www.macworld.com/getinfo

Go Online!

- INSTANT Online Quotes
- Overnight Services
- 24 Hour Press Proofs
- Submit Jobs Online
- Expert Tech Support
- A Price You'll Like
- Many People To Help

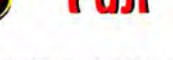

Polaroid PDC-3000

★★★★★
Digital Camera
List \$2495
Our Price **\$799**
Limited Quantities
1-800-769-4049

"Macworld Shopper positions us in a marketplace where we can give readers and web-surfers the best buying and selling options possible."
Michael Snyder, President
The Computer Exchange
www.macfalltrades.com

DATA RECOVERY

ALSO IN CALIFORNIA For MAC - (Hard Drives, Opticals, Removables)

By Nick Majors' DATA RECOVERY LABS
"The Best Data Recovery Service available - Anywhere - at any Price!"

Dedicated In-house MAC specialists are available to work on your emergency data recovery. Complete facility with clean rooms and full MAC capabilities.

Free evaluations. All recoveries are 100% satisfaction guaranteed. Complicated / top priority projects are our specialty.

Datarec.com
DATA RECOVERY LABS

USA • Canada • Japan

1-800-563-1167
www.datarec.com

CD-ROM PRODUCTION

1000 Retail-Ready Stamped CDs
Includes two color discs, four color glossy insert & tray cards, jewel case, and poly wrap. Complete turnkey — just send a CD-R and art files! Call for details.

- Easy to use labeling kits
- CD-R silk screening service
- Short run CD-R duplication
- 4.1Gb/hour standalone duper

CD-R media as low as \$1.49

Your CD-ROM Production Source™
<http://www.catalogic.com>

990 Richard Avenue, Suite 109 • Santa Clara, CA 95050
Telephone: 408-486-0800 • Fax: 408-486-0809

800-255-4020

Choose 450 at www.macworld.com/getinfo

WHOLESALE WATERLESS COLOR PRINTING FROM YOUR COMPUTER FILES

1000 FULL COLOR BUSINESS CARDS FOR \$100 Sug. retail price \$179
1000 FULL COLOR POSTCARDS FOR \$149 Sug. retail price \$249

Printed waterless at 300 line screen from your computer files on Super Premium 10pt. Kromekote with our FREE scratch-resistant aqueous coating.



**Try Our
Fast 4/C Print
Quotes!**

The Batik Boutique

- BUSINESS CARDS
- POSTCARDS
- CD INSERTS
- CD TRAY LINERS
- BROCHURES
- BOOKLETS
- NEWSLETTERS
- POSTERS & MORE



Now At
Kingsgate Plaza

FEATURING 300 LINE SCREEN WATERLESS OFFSET PRINTING

Rates for Brochures, Booklets and Flat Sheets are also available.

4-COLOR WATERLESS SPECIAL **YEAR 2000 CALENDARS** **\$6184**
 1,000 8.5" x 11" 28-Page 4-Color Calendars printed from your computer files on 100 lb. glass text. Includes full bleed, all bindery and FREE aqueous coating.
Get 5,000 Calendars for only \$8,490 SUGGESTED RETAIL \$10,283



4413 82nd Street • Lubbock, TX 79424 • FAX: 806.798.8190

QUARK
Authorized
Service Bureau

Factory Authorized
COREL
Service Bureau

Se Habla
Español

GRAPHIC ARTS
AVAILABLE

Email your requests for printing quotes to request@copycraft.com

1.800.794.5594

CALL TODAY FOR A FREE COPY OF OUR NEW 32-PAGE FULL COLOR CATALOG

Visit www.copycraft.com for more Waterless Specials!

Choose 455 at www.macworld.com/getinfo

data recovery

www.mcrecovery.com



When you absolutely, positively have to get your data back...

- 24hr. Emergency Data Recovery
- Worldwide Services

MICROCOM
 20802 Plummer St. Chatsworth, CA 91311 • 818 718-1200
800 469-2549



visit our website at www.colorprints.com for the lowest prices on digital color prints

Choose 456 at www.macworld.com/getinfo

MAC REPAIR & UPGRADE

24 HOUR SERVICE TURNAROUND • LONGER WARRANTY
 FREE DIAGNOSTIC • COMPETITIVE PRICE



- * Specialize in component repairs:
 - Power Mac • Power Book • Logic boards
- * Advance Exchanges

DT & T
 MACINTOSH
 SERVICES, INC.

800-622-7977

3095 Osgood Court, Fremont, CA 94539 • Tel: 510-661-0999 • Fax: 510-661-6788
<http://www.dttservice.com>

Choose 454 at www.macworld.com/getinfo

800-WE-FIX-MACS

Free Diagnostics • Best Prices • Best Warranties • Huge Inventory

7100 Logic Board...from \$129	6100 8/0..... from \$99	Apple 24x CD Rom \$99
6400 Logic Board...from \$299	7100 8/0.....from \$199	
6500 Logic Board...from \$299	8100 8/500..... from \$399	Apple 4GB SCSI HD \$179
7500 Logic Board...from \$199	20th Anniversary Base & Unit..... \$1499	Apple 1GB SCSI HD \$99
8500 Logic Board...from \$199		
8600 Logic Board...from \$299		
9500 Logic Board...from \$299		
9600 Logic Board...from \$299		

**G3/iMac Parts
In Stock!**

**PowerComputing
Specialists**

2202 N. First Street San Jose, CA 95131 • 800 933-4962 • www.allmac.com

DATA RECOVERY: 800-440-1904

"Thanks for saving my butt!"

- Guy Kawasaki, *The Macintosh Way*

7 good reasons to choose DriveSavers:



Since 1989
INTL: 415-382-2000

1. We are the fastest, most trusted, and most successful data recovery professionals.
2. Retrieve recovered data instantly with DATAEXPRESS™ over secured Internet lines.
3. Recommended and certified by all drive companies to maintain your warranty.
4. 24-hour, onsite, and weekend service available.
5. Advanced, proprietary recovery techniques.
6. Featured by CNN, BBC, Forbes, and others.
7. Federal and State Contracts (GSA, CMAS.)

Reseller & Service Companies: Call about DriveSavers' Referral Program.

www.drivesavers.com

Choose 461 at www.macworld.com/getinfo

For COLOR PHOTO BUSINESS CARDS

YOU DO THE MATH!

1000 Full Bleed Business Cards
200 Linescreen - Photo Quality
4 Color Process - Heidelberg
10 Point Coated Cardstock
+ 5-7 Day Turnaround
\$59.95 (plus \$45 initial setup fee)
- Resale Prices Available!

SEND BY MEDIA:
CD Rom • Zip 100

SEND BY INTERNET:
ftp Site • eMail Attachment

APPLICATIONS:
QuarkXpress • Photoshop • Illustrator

1-800-772-9993
www.daicolocard.com



DDAICOLO CORPORATION
21203A Hawthorne Boulevard, Torrance, CA 90503

Choose 462 at www.macworld.com/getinfo

Data Recovery in hours.

- Over 10 years of experience with clients worldwide including Apple, NASA, HP, and FedEx.
- We've recovered more than half-a-million megabytes of Mac Data alone.
- You only pay when there's a recovery.
- Express One-Day Service is available.
- Call 24 hours a day.

415-495-5556 • FAX 415-495-5653 • RESTRICTIONS MAY APPLY
361 Clementina Street • San Francisco, California 94103



LAZARUS
DATA RECOVERY

Working at the speed of business.

800-341-DATA

Choose 460 at www.macworld.com/getinfo

**TOTAL RECALL
EXTREME
RECOVERY**

877-4MY-DATA
WHATEVER IT TAKES.™

Total Recall™

The Data Recovery Company™

www.totalrecall.com

2462 Waynoka Rd. Colorado Springs, CO 80915

(719) 380-1616 • 380-7022 fax

Choose 459 at www.macworld.com/getinfo

FULL COLOR!



- Super thick card
- Ready in 5-7 days!
- Glossy UV coating
- No film charge



www.postcardpress.com
Preferred by over 5,000 businesses!

1-800-957-5787



- G3 Specialists
- Component-Level Repair
- Largest Inventory
- Mac systems sales
- 10 Years Experience
- 24 Hour Turnaround

Visit online at:

www.urbancomputer.com

101 East Alma Ave, San Jose, CA 95112

Phone: 408-280-1133

Fax: 408-280-6840

E-mail: sales@urbancomputer.com

Choose 458 at www.macworld.com/getinfo

DON'T MISS THE BUS!



Get on board with Macworld Live!

The New York production of Macworld Live continued the tradition of unsurpassed show coverage and editorial excellence by delivering the best of Macworld Expo NY '99 to both show attendees on-site, and virtual attendees tuning in from cyberspace. Thousands of cyber attendees dialed in to view and hear live coverage of the show on Macworld.com, including Steve Jobs' Keynote and original Macworld Live programming.

Did you miss the bus and the show?

Not to worry! Macworld has the Best of the Show and you covered!

Check it all out at: www.macworld.com/expo where you'll find everything you may have missed—hear the inside scoop from top executives of Apple, Microsoft and industry insiders; learn software secrets and hardware tips from award-winning developers and Macworld Lab's technicians; find out what all the "iBook" buzz is about—digest the Steve Jobs' keynote at your leisure.



Attention Marketers!

Capture the attention of hundreds-of-thousands Macintosh enthusiasts, live and on-line, at the San Francisco Macworld Expo in January 2000! Put your products in touch with the most active Macintosh buyers—don't miss this opportunity for maximum brand exposure! Find out how Macworld Live can work for you; call your local Macworld sales rep today. Or contact Karla Kyrias at 415-278-8542, karla_kyrias@macworld.com for more information.

The Desktop Critic

by David Pogue

Steven Saves the Mac

INSPIRED BY ERNEST LAWRENCE THAYER'S "CASEY AT THE BAT"

STEVE JOBS GAVE HIS recent Macworld Expo keynote iCEO speech exactly two years after his first in 1997, when he had just rejoined Apple as its newest leader. In those two years, he's turned Apple, then a condemned property, into a hot, thriving, profitable company—a feat that all agreed was impossible. If you've ever read the classic poem "Casey at the Bat," you can't help but notice a few parallels . . .

The outlook wasn't brilliant
For the Apple team that year;
Its market share was down to four;
The end, they thought, was near.
When revenues went up in smoke,
And laptops did the same,
The die-hard fans themselves
Began to look away in shame.

A straggling few abandoned ship
For Windows. But the rest
Clung to the hope which
springs eternal
In the human breast;
They fantasized that Steve Himself,
Evicted long ago,
Might somehow have a crack at being
Savior/CEO.

But "Diesel" Spindler had the job,
And Gil came after him;
The former was a washout,
And the latter way too grim;
So on the stricken multitudes,
Dark melancholy sat,
For no one thought that Steven Jobs
Would get a chance at bat.

But Diesel blew it big time,
And was ousted by the board,
And Gil, with golden parachute,
Abruptly pulled the cord.
And when the dust had lifted,
And they saw what had occurred,

Now Steve was back at Apple's helm:
The triumph of the nerd!

There was ease in Steven's manner
As he stepped into his place;
There was pride in Steven's bearing
And a smile on Steven's face.
The kid who'd started Apple
With a vision in his teens
Was once again a superstar—
In turtleneck and jeans.

The media was scornful
As he formed the board anew;
The faithful screamed in protest
As he axed the Newton, too.

And now he's on the
Expo stage,



And now the world awaits,
And now he tells the world he's made
A deal with William Gates!

The crowd went wild with anger;
There went up a muffled roar,
Like the beating of the storm-waves
On a stern and distant shore.
"Let's kill him! Kill the traitor!"
Shouted someone, red with rage;
And it's sure they would have killed him
Had he not been up onstage.

"My friends, you know not what you say,"
Began the fabled man,
"I still think Apple can be saved—
I've got a secret plan!"
Reporters scoffed. They shouted back:
"No matter what you say,
You cannot run a company
Without an MBA!"

But then there came the iMac:
Steven's baby, Bondi blue;
As sales and shipments rocketed
The stock quadrupled, too.
The profits Apple took in now
Were not to be believed—
No wonder; frills like free support
And floppies had been "Steved."

The ugly beige of yesteryear
Was next in line to go;
The Power Macs, in shades of blue,
Made Pentiums look slow.

And ads, and games, and USB . . .
He cleaned up Apple's house.
Each choice he made was brilliant!
(Well, except the iMac mouse.)

Then one by one, the pundits
Started eating public crow;
The Apple-bashing know-it-alls,
It turns out, didn't know.
Soon buying Macs was cool again,
And cutting-edge, and smart—
As Microsoft got stuck in court
And Compaq fell apart.

Oh, somewhere in this favored land,
The market share is low,
The red ink's flowing somewhere,
And somewhere sales are slow.
And somewhere critics slaver,
And somewhere moods are black;
But by God, there's joy at Apple—
Steven Jobs has saved the Mac! **m**

DAVID POGUE (www.davidpogue.com) cowrote *Macworld Mac Secrets*, fifth edition, and authored *The iMac for Dummies* (both from IDG Books Worldwide, 1998).



Sometimes Newer Is Better Than New.



Faster! Faster! Faster!



Play games on your beige or blue Mac the way they were meant to be played. Just plug in a MAXpower™ G3 upgrade card from Newer Technology. Topping out at a blistering 466MHz, these patent-pending cards give you the smooth, flawless game play you want, at a price you can't beat. And right now, you can get a free copy of Tomb Raider II* with every Newer upgrade card you purchase. Newer is the largest G3 upgrade provider and leads the industry in compatibility. So check our web site for a complete list of supported systems, then get the most out of your Mac gaming experience.

To get your FREE* copy of Tomb Raider II, check out our web site at www.newertech.com or call 316-943-0222 ext. 290.



To learn how to get the most from your Mac, visit us at www.newertech.com.

Newer is a registered trademark and MAXpower is a trademark of Newer Technology, Inc. TOMB RAIDER is a registered trademark of Core Design Ltd. TOMB RAIDER and LARA CROFT and LARA'S IMAGE are trademarks of Core Design Ltd. EIDOS and EIDOS INTERACTIVE are trademarks of Eidos Interactive, Inc. Copyright 1997/1999 Eidos and Core. All other product names are trademarks or registered trademarks of their respective holders. No part of this document may be reproduced mechanically, electronically or by any other means without the express written permission of Newer Technology, Inc. All rights reserved. *This offer is valid through November 30, 1999. Additional rules apply. See web site or call for details.

First cousins.



Say hello to the extended family. Looks aside, personality traits like comfort, functionality, and plug-and-play simplicity are all Kensington. Guess you could say the apple doesn't fall far from the tree . . . sorry, couldn't resist.

To get the scoop on our USB products for the iMac™ visit www.kensington.com/imac or your favorite iMac dealer.

KENSINGTON

Smart design at work.

Kensington is a registered trademark of ACCO World Corporation. All other registered and unregistered trademarks are the property of their respective owners. iMac is a trademark of Apple Computer, Inc. Kensington sells mice and trackballs that are compatible with Apple's Macintosh computers. No endorsement of these products by Apple Computer, Inc. is intended or implied. ©1999 Kensington Technology Group, a division of ACCO Brands, Inc.

Choose 1 at www.macworld.com/getinfo