

## AIRE PRO Outdoor CPE

# FAQs



## Model: AOL-J912

4G LTE Cat 12 Outdoor CPE

LTE Network Bands

B1/B2/B3/B4/B5/B7/B8/B9/B12/B13/B14/B17/B18/B19/B20  
B21/B25/B26/B28/B29/B30/B32/B38/B39/B40/B41/B66

SKU: 800024011

# Troubleshooting & FAQ

---

## 1. What can I do if the login page does not appear?

- Verify that the computer is set to obtain an IP address automatically from the Device.
- Test with <http://192.168.0.1> (if default IP address not changed).
- If your computer failed to obtain IP addresses from the device, you can try to set IP addresses manually.
- Verify that <http://192.168.0.1> is correctly entered into the web browser and click Login.
- Use another web browser and try again or try to clear your browser history or cache memory.
- Reboot your device and try again.
- Disable and enable the active network adapter and try again.
- Try Resetting the device, refer to Troubleshooting and FAQ Q3.
- If the issue persists, kindly contact to your service provider.

## 2. What can I do if I cannot connect to Internet?

- Check Signal LED status for receiving signal quality, refer to the LED definitions for details.
- Verify that your SIM card is installed properly and activated.
- Verify that your SIM card has sufficient credit and/or a data plan has been set up with your ISP (service provider).
- Verify that your SIM card and device is in your ISP's service area.
- Verify that your device is connected to the network. You can login to the Online Portal (WebGUI) and check your network status on the dashboard.
- Try the diagnostic page. Login to the Online Portal (WebGUI) and perform a ping test to a known IP and web URL, such as, 8.8.8.8 or [www.google.com](http://www.google.com).
- Try Resetting the device, refer to Troubleshooting and FAQ Q3.
- If the issue persists, kindly contact your service provider.

## 3. How do I restore the device to its factory default settings?

There are two ways to perform a Reset to Factory defaults of the Device:

Option 1) With the device powered on, press and hold down the **RESET** button on the bottom panel of the device for about 10 seconds, then release it. The device will restore and reboot automatically.

Option 2) Login to the web management page (WebGUI) of the device and go to Settings > Basic > Management > Restore, click the Restore button and wait until the reset process completes.

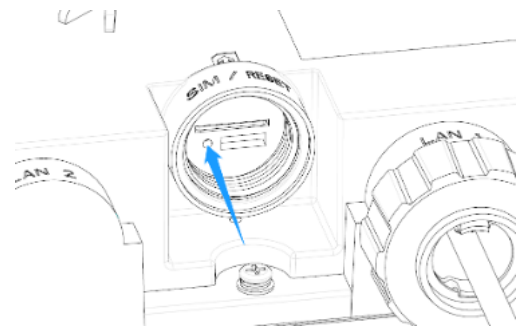

**Note:** During the Reset process, Ensure the uninterrupted power supply to device from PoE injector.

## 4. What can I do if I forget my web management page password?

- Refer to Troubleshooting and FAQ > Q3 to restore the device to its factory default settings and then use the default Username “admin” and Password shown on the device label to login.

## 5. How do I insert the SIM Card?

- Open the SIM Slot section (as shown below) and insert the SIM card into the slot until you hear a click. Then close it.

**Note:** Use a standard SIM card (2FF).

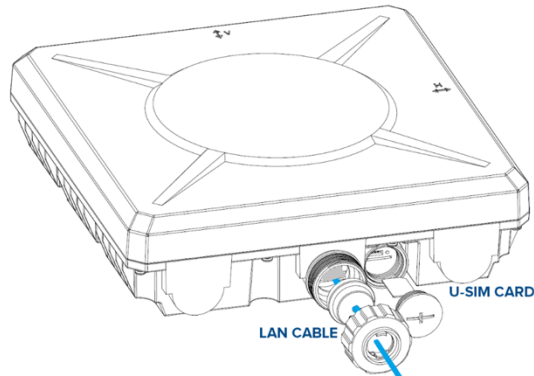

## 6. How do I check signal level and power status?

- Locate the signal indicators on the rear panel of the device (see image to the right).

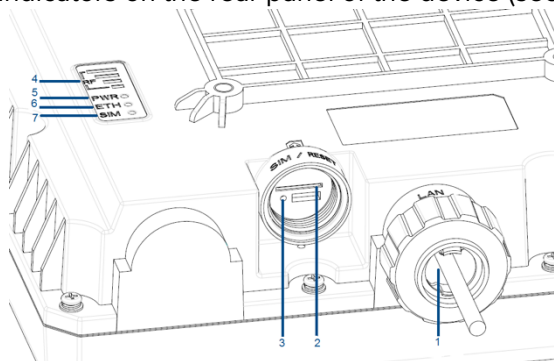

- Indicator lights will indicate Signal Level, Power Status, SIM and Ethernet Status as follows:

LED	Status	Color	Description
RF/Signal	4-Bar	Green	Best receiving signals, SINR > 11dB
	3-Bar	Green	Good receiving signals, SINR 5 ~ 10dB
	2-Bar	Green	Normal receiving signals, SINR 1 ~ 4dB
	1-Bar	Green	Weak receiving signals, SINR - 2 ~ 0dB
	No Bar	-	No/Very Weak receiving signals, SINR < - 2dB
PWR	On	Green	Device is Powered On
	Off	-	Device is Powered Off
ETH	On	Green	Ethernet/LAN connection is established.
	Off	-	Ethernet/LAN connection is not established.
SIM	On	Green	SIM card is inserted/detected.
	Off	-	SIM card is not inserted/detected.

7. How do I access the Online Device Portal (WebGUI)?

- Once your Computer/PC is connected to the device (Outdoor CPE AOL-J912) over Ethernet, you can see the ETH (Ethernet) LED in the “On” state.
- To access the configuration webpage, open a web-browser and type the default address, <http://192.168.0.1> in the address field of the browser.

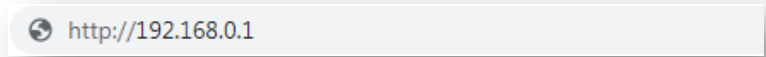

- After a moment, a login window will appear. Enter **admin** for the Username, and Password shown on the device label. Then click the Sign In button.

Username  
  
Password

**Note:** If the above screen does not pop-up, try clearing your web browser cache memory. You can also try checking the connection with ping. Open the command prompt and input to **ping 192.168.0.1**. You should see the ping response if a LAN connection has been established.

- Once you’ve successfully logged in, you will see a Dashboard page where all the basic configurations related to the device are presented for quick check (i.e. SIM status, Connection Status with Network and Network Parameters).

**ATEL** VZW LTE English Logout

Dashboard Status Settings LTE

<b>Network</b> Status: Connected Band: 66 RSRP: -107 dBm RSRQ: -9 dB SINR(-20 to 35): 14	<b>WAN Info</b> IP: 100.122.5.74 Netmask: 255.255.255.252 Gateway: 100.122.5.73 ISP DNS: 198.224.169.135 MAC Addr: 16:A9:4D:76:22:C4
<b>Data Traffic:</b> Received Traffic* (DL): 0 MB Sent Traffic* (UL): 0 MB Total Traffic* (DL+UL): 0 MB Session Time: 00:11:26 <small>*traffic since last reset, restart or reconnection of the device</small> <input type="button" value="Reset"/>	<b>Device SIM Info</b> Router Version: CPE3_WT_J912_00_V0.0.2 LTE Version: EM12GPAR01A21M4G UICCID: 8914800008319468306 IMSI: 311480944758445 IMEI: 869710031879806 HW Version: P1

Your device is now ready for use.

## **Disclaimer**

Certain variations may be present between the device and user manual description depending on software release or specific network services. ATEL shall not be held legally responsible for such deviations, if any, nor for their potential consequences.

## **Limited Warranty**

The full ATEL USA Warranty Policy can be found at [www.atel-usa.com/warranty](http://www.atel-usa.com/warranty). On this page you can “Start a Warranty Claim”, “Check on an Existing Claim” and read our Warranty Policy by clicking on “ATEL’s Warranty Policy”. Please follow all warranty instructions available and if you have any questions contact us at [support@atel-usa.com](mailto:support@atel-usa.com).

## **Trademark**

© 2023 Asiatelco Technologies, Inc. All rights reserved.