

**562L UltimateTaste 700 french door refrigerator, matte black with TasteSealPlus convertible drawer, 4 star energy, TasteLockAuto crisper with automatic humidity control, WaterStream in door dispenser & Autolce internal icemaker**

RRP AUS \$3,299.00



## Product Details

### FEATURES

---

Slot-in concept	4 Star energy efficiency	Autolce	WaterStream
TasteSealPlus Drawer	TasteLockAuto Crisper	Four-drawer storage system	EvenTemp
TasteGuard deodorizer	Inverter Technology		

---

### BENEFITS

---

#### DESIGNED FOR A PERFECT FIT

The refrigerator is designed for easy installation and to slide effortlessly into a standard 1800mm height space with a choice of slot-in options for a perfect fit. A slimline door design enables the refrigerator to sit flush with customised cabinetry, leaving a minimal surrounding gap for a seamless kitchen aesthetic. The doors extra-wide opening, up to 122, provides greater ease of access to refrigerator contents.

#### SAVE ENERGY. SAVE MONEY.

The refrigerator carries a 4-star energy rating thanks to Electrolux inverter technology. This high energy efficiency results in lower running costs, so you're saving electricity and money without compromising on performance. You can save up to \$225 in running costs over 10 years\*. \*Saving indicative based on average NSW 24.8/kWh vs 3 star energy rating (see Energy Rating Calculator)

#### NO MORE COMPROMISES

The TasteSealPlus convertible compartment easily adapts to the temperature required, giving you the freedom to store everything from cheeses & deli meats to cold drinks. You can even store meat and fish without freezing (chilled -2C), avoiding the need for inconvenient defrosting. Always find the right space to keep your food fresh and full of flavour by choosing one of the three temperature settings from -2C to 3C.

#### FRESH FRUIT AND VEG, ALL WEEK

TasteLockAuto crispers do what they say they do - lock in taste automatically. These sealed crispers with automatic humidity control maintain the right humidity levels for fruit and vegetables, removing excess moisture, reducing condensation and keeping your produce fresher for longer.

#### ICE ON DEMAND WITH FASTICE

The convenient Autolce automatic ice maker ensures that you always have plenty of ice cubes at hand to cool down your drinks. Choose the FastIce function to increase the speed of the freezing process and produce up to 25% more ice\*.

#### CHILLED WATER ON DEMAND

WaterStream in door water dispenser allows you to effortlessly grab a chilled glass of water directly through the fridge door.

#### OPTIMAL FRESH FOOD STORAGE

Take refrigerator food storage to a new level of efficiency with this flexible four-drawer compartment. This system comprises four drawers, each dedicated to creating optimal storage conditions for specific food preservation needs and storage volumes. Two TasteLockAuto drawers with auto-humidity help retain fruit and vegetables freshness. The TasteSealPlus drawer, with three adjustable temperatures from -2C, 0C and 3C, is designed for chilling foods and drinks, while the DeliDrawer keeps dairy and delicatessen products at their best for longer.

#### OPTIMAL COOLING

EvenTemp multiflow distributes and circulates cold air to every corner of the refrigerator to maintain a uniform temperature. Even after opening the door, the fridge will rapidly recover to the optimal temperature due to the EvenTemp metal multiflow. That means your food will stay fresh and tasty longer.

---

#### CLEAN, HYGIENIC STORAGE

TasteGuard deodoriser uses a carbon filter to help keep your fridge fresh, hygienic, and free from unwanted odours that can change the taste and smell of your food.

#### ENERGY-SMART TECHNOLOGY

Electrolux refrigerator technology delivers greater energy efficiency and quieter noise level\*, while enhancing fridge performance, durability, and longevity. The Inverter Compressor automatically adjusts the running speed in response to cooling demand creating a constant, optimal food storage temperature using significantly less energy\*\*.

---

## Specifications

### PRODUCT PROFILE

Domestic warranty details (yrs)	2
Refrigerator Type	french door
Exterior door finish	Black
Handle design	bar handle
Fridge door opening	left and right
Cooling system	frost free
Refrigerant	R600a
Dispenser type	water
Plumbed water supply required	Yes
Compressor	Inverter

### DIMENSIONS

Total height (mm)	1795
Cabinet height (mm)	1776
Total width (mm)	896
Cabinet width (mm)	890
Total depth (mm)	755
Cabinet depth (mm)	643
Depth door open 90degree (mm)	1112
Air space above total height (mm)	5
Food Compartment Capacity (L) - AS/NZS 4474.1 2007 (IEC 62552-2015) *	405
Freezer Compartment Capacity (L) - AS/NZS 4474.1 2007 (IEC 62552-2015) *	157
Total Capacity (L) - AS/NZS 4474.1 2007 (IEC 62552-2015) *	562

## ENERGY

---

Energy Star Rating - 4  
AS/NZS 4474.1 2007 (IEC  
62552- 2015) \*

---

## FOOD COMPARTMENT

---

### DELI-COMPARTMENT

---

Deli-Compartment Runner system      rollers

---

Half width compartment      1

---

## CRISPERS

---

Crisper lid/shelf      glass

---

Crispers Runner system      rollers

---

Crisper features      automatic humidity control

---

## REFRIGERATOR SYSTEM

---

Controls      electronic (with display)

---

Controls location      internal

---

Controls type      touch

---

Control functions      quick freeze function,quick  
chill,fast ice function,drinks  
chill,ice maker

---

Door alarm      fridge and freezer

---

## SHELVING

---

Shelf material      glass

---

Number of shelf levels      2

---

## LIGHTING

---

Main light      LED

---

**OTHER PROPERTIES**

---

Other Properties-FOOD COMPARTMENT	Wire wine rack,Deodoriser,Water filter
--------------------------------------	---

---

**EXTERNAL**

---

Dispenser through door	water
------------------------	-------

---

**BASKET/DRAWER**

---

Full width freezer drawer	5
---------------------------	---

---

**FOOD COMPARTMENT DOOR**

---

**BINS**

---

Deep bottle bin	2
-----------------	---

---

**FREEZER COMPARTMENT**

---

**ICE FACILITY**

---

Ice cube storage bin	1
----------------------	---

---

Automatic ice maker	1
---------------------	---

---

Ice Maker	Automatic
-----------	-----------

---

# Dimensions

**Models:**  
EQE5657BA, EQE5607BA

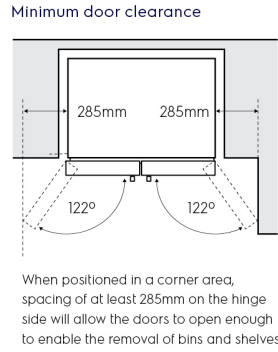
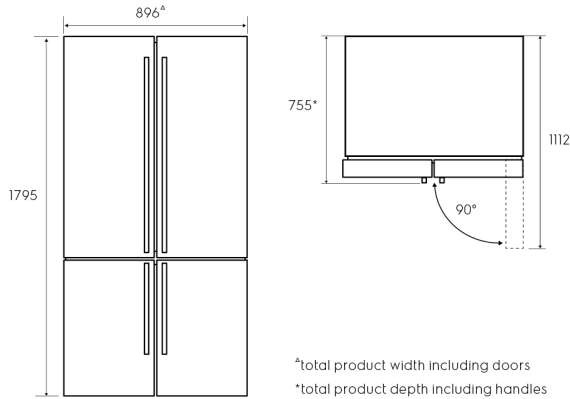

Installation options for optimal aesthetics:

**Minimum side clearance kitchen cabinet**  
Fridge must sit 10mm proud of kitchen cabinetry.  
Minimum cabinetry opening (WxDxH):  
900mm x 649mm x 1800mm

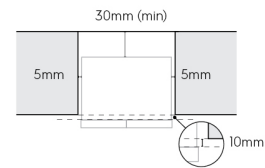

**Front of fridge body in line with kitchen cabinet**  
Side clearance must be 25mm either side of fridge body, to have the fridge doors siting proud of the kitchen cabinetry.  
Minimum cabinetry opening (WxDxH):  
940mm x 660mm x 1800mm

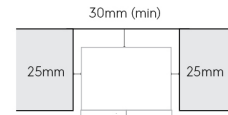

**Fridge door flush with the cabinetry**  
Side clearance must be 25mm either side of fridge body, to have the fridge doors siting proud of the kitchen cabinetry.  
Minimum cabinetry opening (WxDxH):  
950mm x 724mm x 1800mm

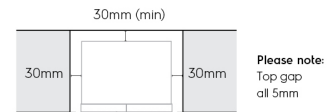

Dimensions	Product Height	Product Width	Product Depth	Product Depth (Door Open)
EQE5657BA	1795	896 <sup>Δ</sup>	755*	1112
EQE5607BA	1795	896 <sup>Δ</sup>	755*	1112

<sup>Δ</sup>total product width including doors  
\*total product depth including handles

Airspace	Side - both (door flush)	Side - both (cabinet flush)	Top	Behind
EQE5657BA	30	25	5	30
EQE5607BA	30	25	5	30

For connection kit installation instructions go to [electrolux.com.au](http://electrolux.com.au)

**Important!** Please ensure that the access to your kitchen (including doorways, corridors, island benches, etc) allows sufficient clearance to move your fridge into position.

**Please note!** Dimensions to be used as a guide only. All customers MUST refer to the user manual supplied with the product for detailed installation instructions.

© 2023 Electrolux Home Products Pty Ltd. E\_DIM\_EQE6870BA-SA\_Jan23

## Terms and Conditions

### IMPORTANT

This is a guide of product dimensions only. For complete installation instructions, refer to the manual provided with product.

### PRODUCT INFORMATION

The descriptors and illustrations in this publication apply to the specific products and models described as at the date of issue. Under our policy of continuous product development, product specifications may change without notice. Prospective purchasers should therefore check with their retailer to ensure this publication correctly describes the products that are being offered for sale. All information supplied is to be used for general reference purposes only and is on the understanding that Electrolux Home Products Pty Ltd (Australia) and Electrolux (NZ) Ltd (New Zealand) will not be liable for any loss, liability or damage of whatever kind arising as a result of reliance on such information. Colours of products illustrated are as close as printing limitations allow. Electrolux will at all times comply with its obligations pursuant to law including Trade Practices (Australian Consumer Law) Act and Regulations.

### WARRANTY

This warranty only applies to Appliances purchased and used in Australia or New Zealand and used in normal domestic applications and is in addition to (and does not exclude, restrict, or modify in any way) any non-excludable statutory warranties in Australia or New Zealand. All warranties are subject to the conditions set out in the warranty card accompanying the product when purchased.

#### ELECTROLUX HOME PRODUCTS AUSTRALIA

telephone: 1300 363 640

fax: 1800 350 067

email: [customercare@electrolux.com.au](mailto:customercare@electrolux.com.au)

web: [www.electrolux.com.au](http://www.electrolux.com.au)

#### ELECTROLUX HOME PRODUCTS NEW ZEALAND

telephone: 09 573 2230

fax: 09 573 2221

email: [customercare@electrolux.co.nz](mailto:customercare@electrolux.co.nz)

web: [www.electrolux.co.nz](http://www.electrolux.co.nz)