

Yale®



Yale®

EN - Translated Operating Instructions (Also applicable for special versions)

Electric chain hoist

CPV(F)

Columbus McKinnon Industrial Products GmbH

Yale-Allee 30

42329 Wuppertal

Germany

CMCO
COLUMBUS MCKINNON

Table of Contents

Introduction	23
Permanent Sound Pressure Level.....	23
Theoretical service life.....	23
Regulations.....	23
Correct operation	23
Incorrect operation.....	24
Assembly	26
Electrical Connection.....	28
Inspection before initial operation	30
Operation	30
Inspection, Service & Repair	31
Transport, Storage, Decommissioning and Disposal	38

INTRODUCTION

Products of CMCO Industrial Products GmbH have been built in accordance with the state-of-the-art and generally accepted engineering standards. Nonetheless, incorrect handling when using the products may cause dangers to life and limb of the user or third parties and/or damage to the hoist or other property.

The operating company is responsible for the proper and professional instruction of the operating personnel. For this purpose, all operators must read these operating instructions carefully prior to the initial operation.

These operating instructions are intended to acquaint the user with the product and enable him to use it to the full extent of its intended capabilities. The operating instructions contain important information on how to operate the product in a safe, correct and economic way. Acting in accordance with these instructions helps to avoid dangers, reduce repair costs and downtimes and to increase the reliability and lifetime of the product. The operating instructions must always be available at the place where the product is operated. Apart from the operating instructions and the accident prevention act valid for the respective country and area where the product is used, the commonly accepted regulations for safe and professional work must also be adhered to.

The personnel responsible for operation, maintenance or repair of the product must read, understand and follow these operating instructions.

The indicated protective measures will only provide the necessary safety, if the product is operated correctly and installed and/or maintained according to the instructions. The operating company is committed to ensure safe and trouble-free operation of the product.

PERMANENT SOUND PRESSURE LEVEL

The equivalent permanent sound pressure level at the workplace of the operating staff is ≤ 70 dB. It was determined with the use of the measurement surface sound pressure level method (distance from lifting device 1 m, 9 measuring points, precision class 2 DIN 45635).

THEORETICAL SERVICE LIFE

The Yale electric chain hoist CPV/F is classified in accordance with FEM 9.511 in the FEM Group 1Am /M4. This theoretically results in a service life of 800 operating hours under full load.

Basic principles for the calculation of the theoretical remaining service life are given in DGUV Vorschrift 54. When the theoretical remaining service life has been reached, the hoist should be subjected to a general overhaul.

REGULATIONS

Before the initial start-up, a check must be performed by a competent person as per the mandatory accident prevention rules applicable in the user's country, as well as in accordance with the recognised rules for safety and proper working.

In Germany, these are the accident prevention specifications of the Trade Association DGUV Vorschrift 52, DGUV Vorschrift 54, DGUV Regel 100-500 and VDE 0113-32/EN 60204-32:2008.

CORRECT OPERATION

The Yale CPV/F electric chain hoist production series has been designed to lift and lower loads up to the rated capacity. In combination with a trolley, the device is also ideal for the horizontal movement of overhead loads.

Any different or exceeding use is considered incorrect. Columbus McKinnon Industrial Products GmbH will not accept any liability for damage resulting from such use. The risk is borne by the user resp. operating company alone.

The lifting capacity indicated on the hoist/trolley is the maximum safe working load which must not be exceeded.

ATTENTION: The unit may be used only in situations in which the load carrying capacity of the device and/or the supporting structure does not change with the load position.

ATTENTION: Note that depending on the type of load, the lifting height may be reduced for models with chain container!

The attachment point and its supporting structure must be designed for the maximum loads to be expected.

The selection and calculation of the appropriate supporting structure are the responsibility of the operating company.

The suspension bracket (or the optional trolley) as well as the load hook of the unit must be in a vertical line above the load centre of gravity (S) when the load is lifted, so that load sway can be avoided during the lifting process.



The following are applicable to devices in a trolley:

The hoist is suitable for a wide range of beams as well as various profiles (e.g. INP, IPE, IPB, etc.) with a maximum inclination of the beam flange not exceeding 14° .

The runway must only have a deflection of maximum $1/500$ of the span even under maximum load.

The longitudinal gradient of the travel path surface may not exceed 0.3%.

The air gap between the wheel flange and the beam flange ("dimension A") must be 2.0 mm on either side of the trolley.

Always transport loads in the horizontal direction slowly, carefully and close to the ground.

In manual trolleys without a winch drive, the suspended load must be pushed. It cannot be pulled.

Under no circumstances can a device or unit with an attached load be pulled via control cable!

If the area in front of the load is not sufficiently visible, the operator must make sure that he is given help.

Do not allow personnel to pass under a suspended load.



After lifting or tensioning, a load must not be left unattended or remain lifted for a longer period of time.
 The operator may start moving the load only after it has been attached correctly and all persons are clear of the danger zone.
 The operator must ensure that the hoist/trolley is attached in a manner that does not expose himself or other personnel to danger by the hoist, trolley, chain(s) or the load.
 The units can be operated in ambient temperatures between -20 °C and +50 °C. Consult the manufacturer in case of extreme working conditions.

ATTENTION: Before using the device at ambient temperatures of less than 0°C, make sure that the brake is not frozen by lifting and lowering a small load 2-3 times.

Prior to operation of the load lifting attachment in special atmospheres (high humidity, salty, caustic, alkaline) or handling hazardous goods (e.g. molten compounds, radioactive materials) consult the manufacturer for advice.
 When the unit is not in use, position the suspension above the normal head height, if possible.
 Only use safety hooks with safety latches.
 If the lifting device is used in a noise-intensive environment, it is recommended that the operator as well as maintenance staff wear ear protection.
 In order to ensure correct operation, not only the operating instructions, but also the conditions for inspection and maintenance must be complied with.
 If defects are found or abnormal noise is to be heard stop using the hoist/trolley immediately.

ATTENTION: Disconnect the power supply without failure before performing repair and maintenance work, even if the type of check rules this out!

Maintenance work and the annual inspection of the units must not be carried out in explosive environments.

INCORRECT OPERATION

(List is not complete)

Do not exceed the rated load capacity (nominal load) of the trolley (if applicable) as well as the load of the supporting structure.
 The unit must not be used for pulling free fixed loads. It is also prohibited to allow loads to drop when the chain is in a slack condition (danger of chain breakage).
 The hoist must not be used for pulling loads at an angle.
 Removing or covering labels (e.g. adhesive stickers), warning information signs or the rating plate is prohibited. Removed or illegible labels and instructions must be immediately replaced.
 When transporting loads ensure that the load does not swing or come into contact with other objects.

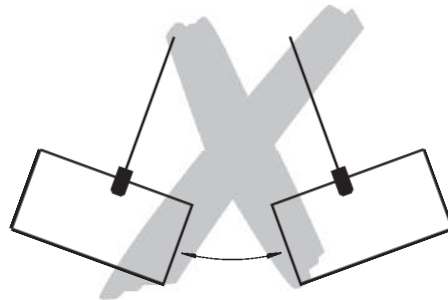

Excessive inching operation by short and frequent actuation of the control switch should be avoided.
 Do not use the hoist/trolley for the transportation of people



Welding on optional trolley, hook and load chain is strictly forbidden. The load chain must never be used as a ground connection during welding.

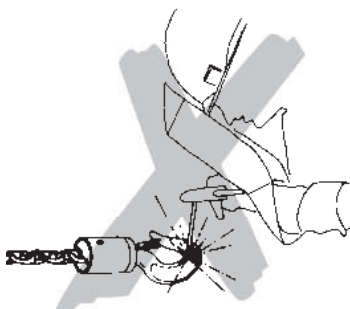

Side pull, i. e. side loading of the top hook (or the trolley for models with trolley), the housing or the bottom block is prohibited. The optional trolley must be perpendicular to the load at any time.

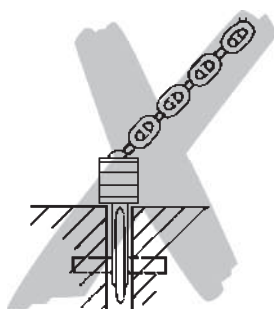

The load chain must not be used for lashing purposes (sling chain).



Do not knot or shorten the load chain by using bolts, screws, screwdrivers or other devices. Load chains that are integral part of the hoist/trolley are not allowed to be repaired.



Do not remove the safety latch from the suspension hook or load hook.



Do not use the chain end stop as an operational limit device.

The load must not be moved into areas which are not visible to the operator. If necessary, he must seek help.

The following are applicable to devices in a trolley:

The longitudinal downward slope of the carriageway must not exceed 0,3 %.

The adjustment of the trolley width must not be extended in order to e. g. obtain a smaller radius curvature.

Any modification of the lifting device is prohibited. A unit modified without consulting the manufacturer must not be used.

Never attach the load to the tip of the hook. The load must always be seated in the saddle of the hook. This also applies to the suspension hook.



Do not throw the hoist or trolley down. Always place it properly on the ground.

Never reach into moving parts.

Only one load lifting attachment may be suspended in the load hook of the hoist.

The unit must not be operated in potentially explosive atmospheres.

ASSEMBLY

Assembly and maintenance of the device is to be entrusted only to persons who are trained in the field in question and have been commissioned by the owner to assemble and service the device.

These persons must know the common accident prevention rules, e.g. "Winches, lifting and hoisting devices (DGUV Vorschrift 54)", "Cranes – power driven winches (EN14492-2)" etc., and must be appropriately trained. They should also be familiar with the operating and installation instructions drafted by the manufacturer.

NOTE: If the unit is operated in the open, it must be appropriately protected against adverse weather conditions (e.g. by roofing).

Inspection Before Assembly

Check for transport damage

Check for completeness

Check that the capacity indication on hoist and bottom block match.

Electric Chain Hoist With Suspension Bracket (Standard version)

In a single thread operation, the suspension bracket is integrated with the long latch side to the right, and in double-thread operation with the long latch side to the left.

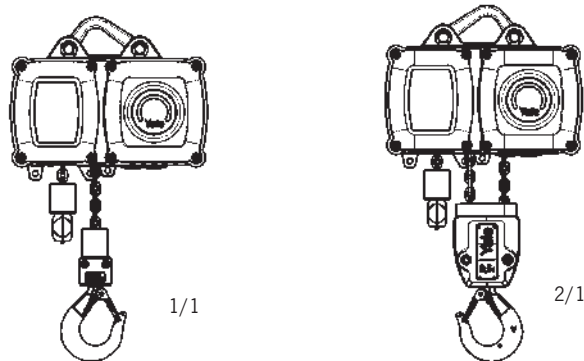

ATTENTION: Do not forget the locking washers following installation of the latch.

The supporting structure must be dimensioned in such a way that the total operating forces can be safely absorbed.

Electric Chain Hoist With Trolley

The devices are delivered as pre-installed and are designed for the beam range A or B specified on the ratings plate. Before installing the chain hoist, make sure that the width of the track beam is within the adjustment range of the delivered trolley.

Trägerbereich/ beam range/ Type de fer	Flanschbreite/ beam width/ largeur de fer [mm]		Flanschdicke/ height of beam / Hauteur du fer [mm] max.
	von/from/de	bis/till/a	
A	50 ¹	180 ¹	19 ¹
	58	180	19
B	180	300	27

¹ CPV/F 2-3, CPV/F 5-4

Assembly Of The Trolley

1. Unscrew the locking nuts (item 9) and hex nuts (item 2) from the crossbars (item 1) and remove both side plates (item 6) from the trolley.
2. Measure the flange width of the beam (measure b).
Adjust measure B between the shoulders of the round nuts (item 5) on the threaded crossbars (item 1). Ensure that the 4 bores in the round nuts face towards the outside. Adjust the measure B to equal measure b plus 4 mm. Measure A must be 2 mm on either side and the centre traverse (item 4) must be centred between the round nuts.
4. Replace one side plate (item 6):
Replace one side plate ensuring that the roll pins (item 8) engage into one of the 4 bores in the round nuts (item 5). To achieve this it may be necessary to rotate the round nuts slightly.
5. Replace the washers (item 3) and tighten the hex nuts (item 2). Screw on the locknuts (item 9) finger-tight and tighten a further ¼ to ½ turn.

Attention: The locknuts must always be fitted.

6. Loosely replace the second side plate (item 6) on the crossbars (item 1). The washers (item 3), hex. nuts (item 2) and locknuts (item 9) can be fitted loosely.
7. Raise the complete pre-assembled trolley to the carrying beam.

ATTENTION: Pay attention to the position of the drive (optionally manual or electric)!

8. Engage the second side plate (item 6) ensuring that the roll pins (item 8) engage into one of the bores in the round nuts (item 5). To achieve this it may be necessary to rotate the round nuts slightly.
9. Tighten the hex nuts (item 2) on the second side plate:
Tighten the locknuts (item 9) finger-tight and then a further ¼ to ½ turn.

Attention: The locknuts must always be fitted.

10. By traversing the trolley check the following:
 - that a clearance of 2 mm is maintained on each side between the trolley wheel flanges and the beam outer edge.

- that the suspension traverse and consequently the unit is centred below the beam.
- that all 4 locknuts (item 9) are fitted .
- that the side plates are parallel.
- that all wheels roll freely and make good contact with the flange of the beam.
- that there are no obstacles on the driving surface.

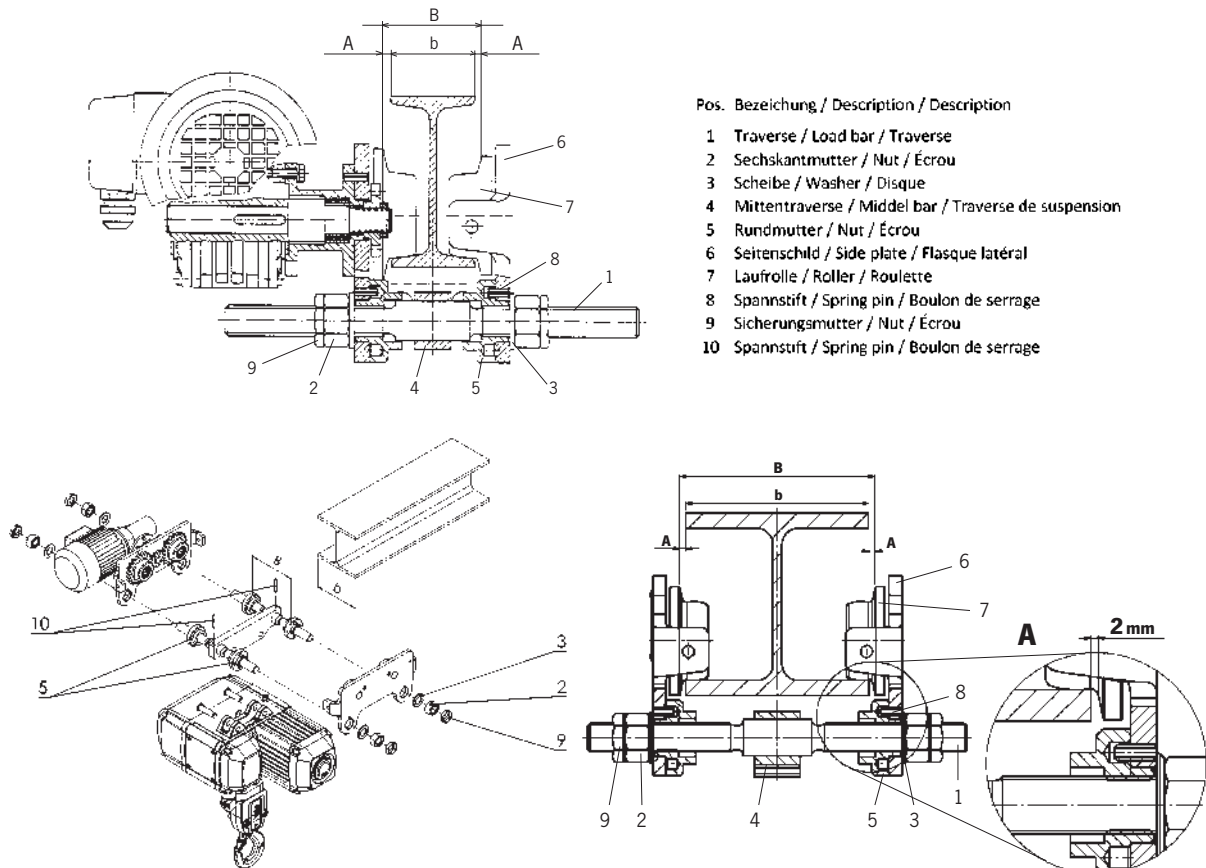

Assembly Of The Hand Chain (Models with hand chain drive only)

To fit the hand chain position the slot on the outer edge of the hand chain wheel below the chain guide. Place any one link of the endless hand chain vertically into the slot and turn the hand chain wheel until the link has passed the chain guides on both sides.

Attention: Do not twist the hand chain when fitting.

Geared trolleys are moved by pulling the hand chain.

Shortening or extending the hand chain (Models with hand chain drive only)

The length of the hand chain should be adjusted so that the distance to the floor is 500 - 1000 mm.

NOTE: For safety reasons, hand chain links may only be used once.

- Look for the non-welded link of the hand chain, bend to open and discard it.
- Shorten or extend the chain to the required length.

ATTENTION: Always remove or add an even number of chain links.

- Use a new link to close the loose chain ends by bending it (for extending the hand chain, two new chain links are required).

ATTENTION: Make sure that the hand chain does not turn during installation.

Installation of the chain stop

The chain hoist is delivered with a correctly installed chain end stop.

The chain end stop must be installed on the idle strand of the load chain so that there is at least one full free chain link under it.

Installation of the chain container

There are three lifting lugs on the housing of the CPV/F electric chain hoist for the optional chain container. Before installation, the load hook is to be lowered to the lowest possible position so that the chain end stop triggers the limit switch on the housing. The chain container can then be installed. Incorrect installation is ruled out by the 3-point fastening.

ATTENTION: While installing the short screw, please make sure that the screw head is on the side facing the motor!

The holding capacity of the chain container to be installed should never be smaller than the load chain length of the device on which it is to be placed. Risk of chain break!

This specification is applicable even if the device is used repeatedly and exclusively to lift loads to lower heights.

NOTE: In multiple strand devices, the load chain length is a multiple of the possible lifting height!

Make sure that the two self-locking nuts are turned on the screws at least so wide that 1½ screw threads project over the nuts.

After installation, check the chain container for smooth working. To do so, lift the load hook over the entire load chain length so that the bottom block triggers the limit switch. During the lifting operation, check the smooth entry of the load chain into the chain container.

ELECTRICAL CONNECTION

ATTENTION: Work at electrical installations may be carried out by electrical experts only. The local regulations have to be strictly observed, e.g. EN 60204-32 / VDE 0113.

Preparation

Before beginning work on electrical components the mains current switch must be switched OFF and secured against unintentionally being switched back on.

Before connecting the chain hoist ensure that the electrical data on the nameplate match the local supply specifications.

Control switch connection

- The length of the pendant control cable is determined by working conditions. Attach the tension relief wire in a manner that the pendant control cable hangs load-free. Cable ends have to be provided with end sleeves.
- The circuit diagram is attached to the device.

Mains connection (3-phase device)

The mains supply cable must be an insulated cable with 4 flexible leads. The ground (earth) lead must be longer than the live leads. The cross section should be at least 1.5 mm² and the cable length should be maximum 50 m. The fuses of the various models can be taken from the tables.

Cable ends have to be provided with wire end sleeves.

The mains supply cable must be connected to the electric chain hoist before it is connected to the mains supply.

- In devices with an electric trolley (CPV/F-VTE/F), the three live phases of the mains supply line are to be connected to the terminal strip within the terminal box of the trolley. The ground/earth wire is to be connected to the special ground/ earth connection within the terminal box of the chain hoist.

- In devices without an electric trolley, the mains power supply is connected to the transformer behind the housing lid (Fig. 18, item 3). The fork-shaped crimp cable lug of the ground cable is joined with a screw and a fan washer to the transformer plate.

Check the motor's direction of rotation.

The wiring diagram included has been drawn for a normal, clockwise rotating installation. Should the user's mains supply not fulfil this standard, and if, after activating the circuit breaker or power supply line, a lowering takes place on pressing the ▲-button on the control switch, deactivate the unit immediately and interchange two of the three phase connections in the control box.

Mains connection (1-phase device)

The mains supply cable must be an insulated cable with 3 flexible leads. The ground (earth) lead must be longer than the live leads. The cross section should be at least 1.5 mm² and the cable length should be maximum 50 m. The fuses of the various models can be taken from the tables.

Cable ends have to be provided with wire end sleeves.

The mains supply cable must be connected to the electric chain hoist before it is connected to the mains supply.

- In devices with an electric trolley (CPV/F-VTE/F), the N conductor, the phase and the ground wire are connected to the corresponding terminal strips in the control box of the trolley.
- In devices without an electric trolley, the mains power supply is connected to the terminal strip of the hoist control plate.

ATTENTION: The settings of the time relay (ZR) should not be disturbed!

Open the housing only 3 minutes after disconnecting the device from the mains. There is risk of an electric shock from undischarged capacitors.

After closing the terminal box cover, connect the other end of the connecting cable to the deactivated circuit breaker or to the mains supply line.

Attention: Under no circumstances may the wiring in the pendant control be tampered with.

Adjustment of the gear limit switch (optional)

If the lifting unit to be installed is equipped with a gear limit switch, the switching points must be adjusted to the use situation without fail before the start-up. After adjusting these switching points, the rope winch and the load as well as the operator can be protected against damage or serious injuries.

This setting could not be defined by the manufacturer because of the unforeseeable number of possible use scenarios.

NOTE: Depending on the customer's request, gear limit switches with up to 6 other actuation cams can be delivered. The gear limit switch translation is to be selected according to the switching space (distance between the highest and lowest switching point).

Modell	P [kW]	n [1/min]	ED [%]	Schaltart / Switching / Connexion	I _n [A]	cos φ	Schaltungen / Counts / Démarrage [ch]	Schutzart / Protection Class / Indice de Protection	Betriebsart / Operation Mode / Mode d'Opération	Sicherung träge / Delay Fuse / Fusible temporisé [A]	
230V											
CPV 2-4, CPV 5-2	230V 1PH/50Hz	0,5	1400	25	C _A = 31,5µF / C _B = 12,5µF	3,3	0,99	150	IP55	S3	16
CPV 5-8, CPV 10-4	230V 1PH/50Hz	1	2800	25	C _A = 100µF / C _B = 30µF	5	0,99	150	IP55	S3	16
CPV 10-4, CPV 20-2	230V 1PH/50Hz	0,75	1400	25	C _A = 60µF / C _B = 30µF	5	0,98	150	IP55	S3	16
230/400V											
CPV 2-8, CPV 5-4	230/400V 3PH/50HZ	0,37	2880	50	Δ/Y	1	0,84	300	IP55	S3	6
CPV 2-20, CPV 5-8, CPV 10-4	230/400V 3PH/50HZ	0,75	2880	50	Δ/Y	1,6	0,85	300	IP55	S3	10
CPV 5-20, CPV 10-8, CPV 20-4	230/400V 3PH/50HZ	1,5	2880	50	Δ/Y	3,2	0,85	300	IP55	S3	16
400V											
CPVF 2-8, CPVF 5-4	400V 3PH/50HZ	0,09/0,37	700/2900	17/33	Y/Y	0,80/1,35	0,47/0,63	200/100	IP55	S3	6
CPVF 2-20, CPVF 5-8, CPVF 10-4	400V 3PH/50HZ	0,18/0,75	620/2800	17/33	Y/Y	0,95/2,0	0,65/0,82	200/100	IP55	S3	10
CPVF 5-20, CPVF 10-8, CPVF 20-4	400V 3PH/50HZ	0,37/1,5	640/2780	17/33	Y/Y	1,60/3,3	0,64/0,89	200/100	IP55	S3	16
CPVF 25-8, CPVF 50-4	400V 3PH/50HZ	0,9/3,6	670/2820	17/33	Y/Y	3,3/7,3	0,64/0,91	200/100	IP55	S3	16
460V											
CPV 2-8, CPV 5-4	460V - 3Ph - 60Hz	0,44	3480	50	Y	0,8	0,85	300	IP55	S3	6
CPV 2-20, CPV 5-8, CPV 10-4	460V - 3Ph - 60Hz	0,9	3480	50	Y	1,6	0,86	300	IP55	S3	10
CPV 5-20, CPV 10-8, CPV 20-4	460V - 3Ph - 60Hz	1,8	3450	50	Y	3,2	0,86	300	IP55	S3	16
CPVF 2-8, CPVF 5-4	266/460V 3PH/60HZ	0,11/0,44	850/3500	17/33	Y/Y	0,80/1,35	0,47/0,63	200/100	IP55	S3	6
CPVF 2-20, CPVF 5-8, CPVF 10-4	266/460V 3PH/60HZ	0,25/0,90	740/3380	17/33	Y/Y	0,95/2,0	0,65/0,82	200/100	IP55	S3	10
CPVF 5-20, CPVF 10-8, CPVF 20-4	460V 3PH/60HZ	0,44/1,8	780/3380	17/33	Y/Y	1,60/3,3	0,64/0,89	200/100	IP55	S3	16
CPVF 25-8, CPVF 50-4	460V 3PH/60HZ	1,08/4,32	804/3384	17/33	Y/Y	3,3/7,3	0,64/0,91	200/100	IP55	S3	16

ACHTUNG / ATTENTION / ATTENTION: träge Sicherung / delay fuse / fusible temporisé

FUNCTION CHECK AFTER INSTALLATION

Prior to operating the hoist, grease the trolley pinions (optional, manual geared and electric trolleys) and lubricate the load chain when it is not under load (see page 9).

Before the hoist is put into regular service, following additional inspections must be made:

Are all screwed connections on hoist and trolley (optional) tight and are all locking devices in place and secure?

Are the end stops on the trolley runway in place and secure?

Is the chain drive correctly reeved?

Is the chain end stop correctly fitted to the loose end of the load chain?

All units equipped with two or more chain strands should be inspected before initial operation for twisted or kinked chains. The chains of 2-strand hoists may be twisted if the bottom block is rolled over.

Perform an operation cycle without load. The chain should move in a steady, smooth way.

Check the limit switch by moving the bottom block and the chain stop against the housing. The lifting or lowering movement must be stopped right away.

Check the sliding clutch with a test weight (min. 125% of the rated capacity, max. 5 s).

Check the brake function when lifting and lowering.

Traverse the trolley (if available) the complete length of the trolley runway ensuring that the 2 - 4 mm lateral clearance between the trolley wheel flange and the beam outer edge is maintained at all times. Check that beam end stops are positioned correctly and secure.

INSPECTION BEFORE INITIAL OPERATION

According to the existing national/international accident prevention or safety specifications, lifting units must be checked

- At least once per year by a competent person
- According to the risk assessment of the operating company,
- Before the initial start-up,
- Before restart following a shutdown
- After basic alterations.

Actual operating conditions (e.g. operation in galvanizing facilities) can dictate shorter inspection intervals.

The checks are essentially visual and functional, which should guarantee that the unit is in a safe condition and if necessary, faults and damages caused by e.g. improper transport or storage, can be identified and remedied.

The condition of components with regard to damage, wear, corrosion or other changes must be assessed, and the completeness and effectiveness of the safety devices must be determined.

Competent persons may be, for example, the maintenance engineers of the manufacturer or the supplier. However, the company may also entrust the inspection to its own appropriately trained specialist personnel. The inspections have to be initiated by the operating company.

Initial operation and recurring inspections must be documented (e.g. in the CMCO works certificate of compliance).

Paint damage should be touched up in order to avoid corrosion. All joints and sliding surfaces should be slightly lubricated. In case of heavy contamination, the unit must be cleaned.

If the hoist is used as a crane, it has to be inspected and approved by a crane expert before initial operation. This inspection has to be registered in the crane inspection book. The inspection by the crane expert has to be instigated by the operating company.

OPERATION

Installation, service, operation

Operators delegated to install, service or independently operate the hoist must have had suitable training and be competent. Operators are to be specifically nominated by the company and must be familiar with all relevant safety regulations of the country of use.

Inspection before starting work

Before starting work inspect the hoist/trolley, chains and all load bearing components every time for visual defects. Furthermore test the brake and make sure that the load and hoist/trolley are correctly attached by carrying out a short work cycle of lifting and lowering resp. travelling in both directions. Selection and calculation of the proper suspension point and beam construction are the responsibility of the operating company.

Inspection of load chain

Inspect the chain for sufficient lubrication and visually check for external defects, deformations, superficial cracks, wear or signs of corrosion.

Inspection of chain end stop

The chain end stop must be connected to the free (idle) chain strand.

Inspection of chain reeving

All units with two or more chain strands should be inspected prior to initial operation for twisted or kinked chains. The chains of 2-strand hoists may be twisted if the bottom block was rolled over.



Inspecting the hooks

Check the load hook and the suspension hook for deformations, cracks, damages, abrasion and signs of corrosion.

Checking the limit switch

If the load hook is moved against the hoist, the limit switch must stop the lifting operation immediately and shut down the motor. The load hook can only be lowered then.

The lowering movement must also be automatically stopped exactly the same way as soon as the load hook reaches the lowest possible position allowed by the load hook length. The load hook can then be raised.

Inspect the traverse (for trolleys)

Inspect the traverse for correct assembly and visually check for external defects, deformations, superficial cracks, wear or signs of corrosion.

Especially make sure that the roll pins are properly fitted to the centre traverse.

Check adjustment of trolley width

On hoists with trolley check that the clearance between the trolley wheel flange and the beam outer edge is equal on both sides and within the tolerances given (see page XX, Fig. XX).

Enlarging the clearances, e. g. to enable the trolley to negotiate tighter curves, is forbidden.

Traversing the hoist

Plain trolley:

Push the hoist or attached load.

Reel trolley:

Geared trolley:

By operating the trolley hand chain.

Electric trolley:

By operating the ► resp. ◀ button.

For trolleys with two speeds: The first stage of button depression activates the slow speed., further depression activates the fast speed. Use the slow speed for short periods only.

Attention: Never pull on the pendant control cable. Suspended loads may only be pushed.

Operation of the locking device (optional for models with an integrated manual trolley)

The locking device is used for easily locking the unloaded trolley (parking position in the shipping sector, for example). The brake shoe is pressed against the beam flange by pulling on the appropriate hand chain fall so that the chain wheel turns clockwise. Only tighten the chain by hand for this process. The locking device is released again by pulling on the other chain fall.

Attaching the load

Attach the load to the hoist using only approved and certified slings or lashing devices. Never use the load chain as sling chain. The load must always be seated in the saddle of the hook. Never attach the load to the tip of the hook. Do not remove the safety latch from the load hook.

Lifting/lowering the load

The load is lifted by depressing the ▲-button, it is lowered by depressing the ▼-button. For hoists with two speeds: The first stage of button depression activates the slow speed, further depression activates the faster speed. The slow speed may only be used for short distances.

In order to raise the load, always use the lowest available lifting speed. The chain must be loaded at this speed and may not lie slack on the floor.

The chain end stop may not be used as operational limit switch.

Limit Switches

The unit has two limit switches for the lowest and highest load hook positions. The limit switches provide safety and should not be reached operationally.

Emergency stop

All movement can be immediately halted by depressing the red, mushroom shaped button on the pendant control.

ATTENTION: The device is not free of tension!

To release the unit, turn the buttons in the clockwise direction.

INSPECTION, SERVICE & REPAIR

Service and inspections may only be carried out by a competent person.

The inspection must determine that all safety devices are present and fully operational and covers the condition of the hoist, lifting gear, accessories and supporting constructions.

The service intervals and inspections noted are for normal working conditions. Adverse working conditions, e. g. heat or chemical environments, can dictate shorter periods.

The Yale electric chain hoist CPV/F conform to FEM group 1Am/M4 in accordance with FEM 9.511. This results in a theoretical service lifetime of 800 operating hours under full load.

This is equivalent to 10 years under normal operating conditions. After this period the hoist requires a general overhaul. Further information is contained in BGV D6 resp. FEM 9.755.

Attention: Maintenance work requires subsequent function testing with nominal load.

Daily Checks

- Visually check the pendant control switch and all cable for damage.
- Function check of the brakes (incl. triggering the EMERGENCY STOP button)
- Function check of the limit switches
- Function check of the overload circuit breaker
- Electric chain hoists with trolley:
- Check that the trolley runway is free from obstructions
- Check that the end stops on the trolley runway are fitted and secure.

Regular Inspections, Service And Testing

According to the existing national/international accident prevention or safety specifications, lifting units must be checked

- At least once per year by a competent person
 - According to the risk assessment of the operating company,
 - Before the initial start-up,
 - Before restart following a shutdown
 - After basic alterations. The concerned use conditions (e.g. operation in galvanizing facilities) can dictate shorter inspection intervals.
- Repair work may only be carried out by a specialist workshop that uses original Yale spare parts. The inspection (mainly consisting of a visual inspection and a function check) must determine that all safety devices are complete and fully operational and cover the condition of the unit, suspension, equipment and supporting structure with regard to damage, wear, corrosion or any other alterations. Initial operation and recurring inspections must be documented (e.g. in the CMCO works certificate of compliance).

If required by the trade association, the results of inspections and appropriate repairs must be verified.

If the hoist (from 1 t lifting weight) is fitted on or in a trolley, or if the hoist is used to move a lifted load in one or several directions, the installation is considered to be a crane and the further inspections must be carried out, in accordance with DGUV Vorschrift 52 Cranes. Paint damage should be touched up in order to avoid corrosion. All joints and sliding surfaces should be slightly lubricated. In case of heavy contamination, the unit must be cleaned.

ATTENTION! Power supply must be disconnected while inspecting the device, unless the type of the examination excludes this!

Maintenance of the load chain

The load chains are case hardened chains having the dimensions 4 x 12.2 DAT, 5 x 15.1 DAT, 7.1 x 20.5 DAT and 11,3 x 31 DAT.

The CPV/F electric chain hoist is specially designed for type of chain. For this reason only chains that have been approved by the manufacturer may be used in these hoists.

Non-compliance with this specification will render the legal warranty or guarantee void of CMCO Industrial Products GmbH with immediate effect.

Lubricating the load chain

The load chain must be lubricated before the first start-up and every month, however after 50 hours of operation at the latest. Under some extreme conditions such as an increased dust effect or a particularly heavy-duty use, the intervals are to be shortened appropriately.

The service life of the load chain can be increased through careful lubrication to 20-30 times compared with a chain that is not serviced.

• The chain must be cleaned before lubrication. Burning off is not permissible. Cleaning methods that do not deteriorate the chain material are to be used (e.g. vapour degreasing, alkaline dip degreasing).

Cleaning methods that can cause hydrogen embrittlement, e.g. pickling or dipping in acid solutions, as well as surface treatments, which can hide cracks or damages, are to be avoided.

• The chain must be lubricated in a tension-free condition so that a lubrication film can be formed at joints. This can happen e.g. through dipping in oil.

Checking for wear

Load chains must be inspected for mechanical damage once every three months and after 200 operating hours at the latest. Particular operating conditions may also dictate shorter inspection intervals.

Visual check: There should be no cracks, deformities, bends, etc. along the entire length of the chain.

Round-section steel chains must be replaced when the original nominal thickness "d" on the chain link with the worst wear has been reduced by more than 10% or if the chain has elongated over one pitch "pn" by 5% or over 11 pitches (11 x pn) by 2%. Nominal values and wear limits are shown in the following tables.

The load chain must be replaced if one of the limit values is exceeded.

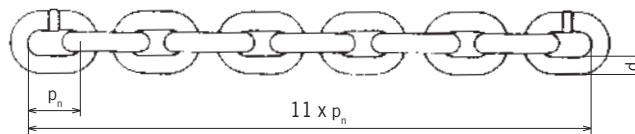

d = Nenndicke der Kette / Nominal thickness of chain
Épaisseur nominale de la chaîne

d₁, d₂ = Istwert / Actual value / Valeur réelle

$$d_{\min.} = \frac{d_1 + d_2}{2} \leq 0,9 d$$

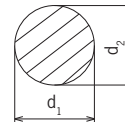

Nominalwerte und Verschleißgrenzen / Nominal values and wear limitation						
Valeurs nominales et limites d'usure						
Rundstahlkette / Round link chain / Chaîne à maillons	[mm]	4 x 12,2	5 x 15,1	7,1 x 21,2	11,3 x 31	
Guteklasse / Grade / Grade		DAT	DAT	DAT	DAT	
Durchmesser / Diameter / Diamètre	d _{nom}	[mm]	4,0	5,0	7,1	11,3
	d _{min}	[mm]	3,6	4,5	6,4	10,2
Teilung / Pitch / Division	p _{n nom}	[mm]	12,2	15,1	20,5	31
	p _{n max}	[mm]	12,8	15,9	21,5	32,5
Meßlänge / Length / Longueur	11 x p _{n nom}	[mm]	134,2	166,1	225,5	341
	11 x p _{n max}	[mm]	136,9	169,4	317,2	347,8

Replacing the load chain

To replace a load chain, it must be suspended and connected to a power source.

A load chain to be discarded must only be replaced by an authorized specialist workshop.

NOTE: Replacement of a load chain must be documented!

1-strand design

1. Dismantling of bottom blocks

Loosen both cylinder screws and separate the two coupling halves.

2. Dismantling the chain end stop

Loosen both screws on the chain end stop. The chain end is now free. Pull out the buffer.

3. Pulling the new chain in

Disconnect the second last one link on the idle strand of the old chain in C shape. The length of the cut section must at least correspond to the thickness of the link. Then, remove the last link and suspend the new chain in the C-shaped chain link. The welded seams of the new load chain must align with those of the load chain to be replaced! The chain can finally be moved in at the lowest possible speed by pressing the ▼-button.

ATTENTION: The C-shaped chain link should not differ from a closed link in outer shape and dimensions. Otherwise, it cannot pass through the hoist during the final entry of the chain. Risk of damage to hoist! Risk of chain break!

4. Installing the chain end stop and bottom block

As soon as the C-shaped chain link passes through the hoist, the old load chain can be hung out and discarded along with the C-shaped auxiliary link. Move the buffer to the ends of the new load chain before installing the chain end stop or the bottom block. The hook head must be re-lubricated while assembling the bottom block.

ATTENTION: The chain end stop must be positioned in such a way that after the installation at least 1 chain link remains. Always use SK nuts with a clamping section.

5. Before initial operation lubricate the unloaded chain and test all hoist functions under no-load condition.

2-strand design

Before starting work, please make sure that the bottom block is fully tension-free.

1. Dismantling the chain bolt

In two-strand models, the chain anchor bolt is placed on the underside of the hoist body. The four cylinder screws (3) of the chain anchor (1) must be detached first. The chain bolt (2) must then be tapped out with a drift.

ATTENTION: Do not damage the bolt or the seat.

2. Dismantle the chain end stop

Remove the two screws. The chain is now free.

3. Pulling the new chain in

Disconnect the second last one link on the idle strand of the old chain in C shape. The length of the cut section must at least correspond to the thickness of the link. Then, remove the last link and suspend the new chain in the C-shaped chain link. The welded seams of the new load chain must align with those of the load chain to be replaced! The chain can finally be moved in at the lowest possible speed by pressing the ▼-button. The load strand end of the old load chain must be kept somewhat stretched continuously to ensure a smooth and upright reeving in the hoist and the bottom block.

ATTENTION: The C-shaped chain link should not differ from a closed link in outer shape and dimensions. Otherwise, it cannot pass through the hoist during the final entry of the chain. Risk of damage to hoist! Risk of chain break!

4. Installing the chain end stop

As soon as the C-shaped chain link passes through the hoist and the bottom block, the old load chain can be hung out and discarded along with the C-shaped auxiliary link. Finally, push the buffer to the idle strand end of the chain and install the chain end stop. After installing the chain end stop, at least 1 chain link must remain.

5. Fitting the chain anchor bolt

Inspect the chain anchor bolt for flaws, cracks or burrs. Enter the last link of the other load chain end into the slot in the underside of the hoist body.

Attention: The chain must not be twisted.

Now enter the chain anchor bolt through the side bore. Move the last link back and forth while entering the chain anchor bolt to ensure that it is not trapped and damaged by the anchor bolt. Secure the anchor bolt with the grub screw.

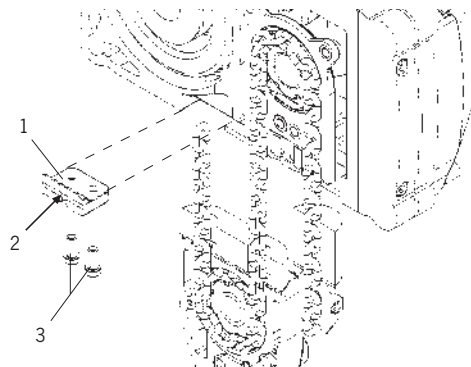

The chain anchor is then joined to the hoist body. New pre-coated safety screws intended for one-time use only must be used here.

Torques for the fastening screws:

M5 = 8Nm / M6 = 10Nm / M8 = 25Nm / M10 = 48Nm

Hardened for working after approx. 60 minutes

Hardening time at ambient temperature approx. 24 hours.

6. Functional test

All units with two or more chain strands must be inspected before every operation for twisted or kinked chains. Chains on 2-strand units may become twisted if the bottom block is rolled over. If a strand is twisted disconnect it from the hoist and re-thread it correctly. In some cases it may be necessary to remove the last link.

7. Before initial operation lubricate the unloaded chain and test all hoist functions under a no-load condition.

Maintenance Load Hook

Check the load hook for deformation, damage, surface cracks, wear and signs of corrosion as required, but at least once a year. Actual operating conditions may also dictate shorter inspection intervals. Hooks that are rejected during the check must be immediately replaced with new ones. Welding on hooks, e.g. to compensate for wear is forbidden.

Hooks must be replaced when the mouth of the hook has opened more than 10% or when the nominal dimensions are reduced by 5% as a result of wear. Nominal dimensions and wear limits are shown in the following table. If the limit values are exceeded, immediately replace the components.

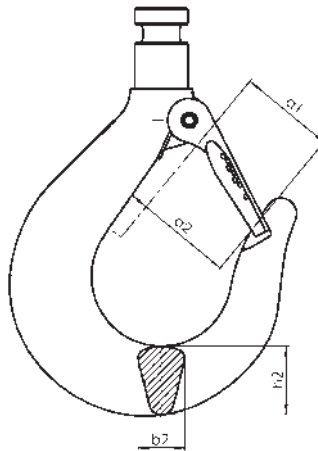

Nominalwerte und Verschleißgrenzen / Nominal values and wear limitation Valeurs nominales et limites d'usure			CPV/F 2-8 CPV 2-4	CPV/F 5-4 CPV 2-2	CPVF 2-18 CPV/F 5-8	CPV/F 10-4	CPVF 5-18 CPV/F 10-8 CPV 10-4/1	CPV/F 20-4 CPV 20-2	CPVF 25-8	CPVF 50-4	
Hakenöffnungsmaß / Hook opening / Ouverture du crochet	Traghaken / Top hook / Crochet haut	δ_{nom} [mm]	30,0	30,0	29,0	35,0	35,0	40,0	45,0 (TY)	45,0 (TY)	
		δ_{sup} [mm]	38,0	38,0	38,0	44,0	44,0	48,0	55,0	55,0	
		δ_{max} [mm]	41,8	41,8	41,8	48,4	48,4	52,8	60,5	60,5	
	Lasthaken / bottom Hook / crochet de charge	δ_{nom} [mm]	30,0	30,0	29,0	35,0	35,0	40,0	41,0	41,0	
		δ_{sup} [mm]	38,0	38,0	38,0	44,0	44,0	48,0	56,0	56,0	
		δ_{max} [mm]	41,8	41,8	41,8	48,4	48,4	52,8	61,6	61,6	
Hakenbreite / Hook width / Largeur du crochet	Traghaken / Top hook / Crochet haut	b_{nom} [mm]	16,0	16,0	15,0	21,0	21,0	28,0	46,0	46,0	
		b_{min} [mm]	15,2	15,2	14,3	20,0	20,0	26,6	43,7	43,7	
	Lasthaken / bottom Hook / crochet de charge	b_{nom} [mm]	16,0	16,0	15,0	21,0	21,0	26,0	29,0	37,0	
		b_{min} [mm]	15,2	15,2	14,3	20,0	20,0	24,7	27,6	35,2	
	Hakendicke / Hook height / Hauteur du crochet	Traghaken / Top hook / Crochet haut	h_{nom} [mm]	16,0	16,0	15,0	21,0	21,0	26,0	46,0	46,0
			h_{min} [mm]	15,2	15,2	14,3	20,0	20,0	24,7	43,7	43,7
Lasthaken / bottom Hook / crochet de charge		h_{nom} [mm]	16,0	16,0	15,0	21,0	21,0	26,0	38,0	48,0	
		h_{min} [mm]	15,2	15,2	14,3	20,0	20,0	24,7	36,1	45,6	

Maintenance Trolleys

In particular check following parts:

- Side plate: For cracks or deformation in particular around the areas of screwed connections.
- Trolley wheels: Visually check for cracks and wear on trolley wheel flanges. Grease the transmission.
- Crossbars: In particular around threaded areas for cracks.
- Fasteners: Check nuts, screws and locking devices for tightness.

Force-limit factor Of Overload Protection Device

The force-limit factor according EN 14492-2:2006 amounts $\varphi_{DAL}=1,55$. The maximum force occurring when the rated capacity limiter operates will be calculated as:

$$FLIM = (\varphi_{DAL} \times mRC + mH - mRC) \times g$$

$$\varphi_{DAL} = 1,55$$

mRC = Rated capacity of the hoist [kg]

mH = Hoist load [kg]

Hoist load mH: Load which includes all the masses of a load equal to the rated capacity of the hoist, the hoist medium and the fixed load lifting attachments, e. g. hooks, grabs, magnets, lifting beams, vacuum lifters.

g = Acceleration due to gravity (9,81) [m/s²]

Testing and Adjustment of overload device

ATTENTION: The settings of the overload circuit-breaker should be defined only by a competent person.

ATTENTION: The unit is ready for operation during this activity and there is a risk of physical injury caused by rotating parts.

ATTENTION: The result of the check and adjustment of the overload circuit-breaker must be recorded in the test log of the device.

The unit is equipped with an overload protection device as standard. This device is factory set to 145% \pm 10 % of the rated capacity and prevents reliably overloading of the hoist during lifting of loads. Adjustment and testing of the overload device may only be carried out by authorized competent persons.

- Loosen the four cylinder screws (item 1) of the fan guard (item 2).
- Remove the fan guard (Pos. 2)
- Disassemble fan (Pos. 4) accordingly the different design (clipped, screwed or with lock ring).
- Loosen the threaded pin of the adjusting nut
- Loosen the adjusting nut by turning it in the anti-clockwise direction up to the stop with a two-hole nut runner in accordance with DIN 3116 (item 6).

ATTENTION: After resetting the adjusting nut, the threaded pin has to be tightened again to secure the setting!

- For a suspended test load, the adjusting nut is to be turned in the clockwise direction until the test load is lifted.

ATTENTION: The max. operating time of the overload circuit-breaker is 60 seconds. Then, the unit has to cool down to a room temperature (min. 20 minutes).

- Assembly takes place in the reverse sequence.

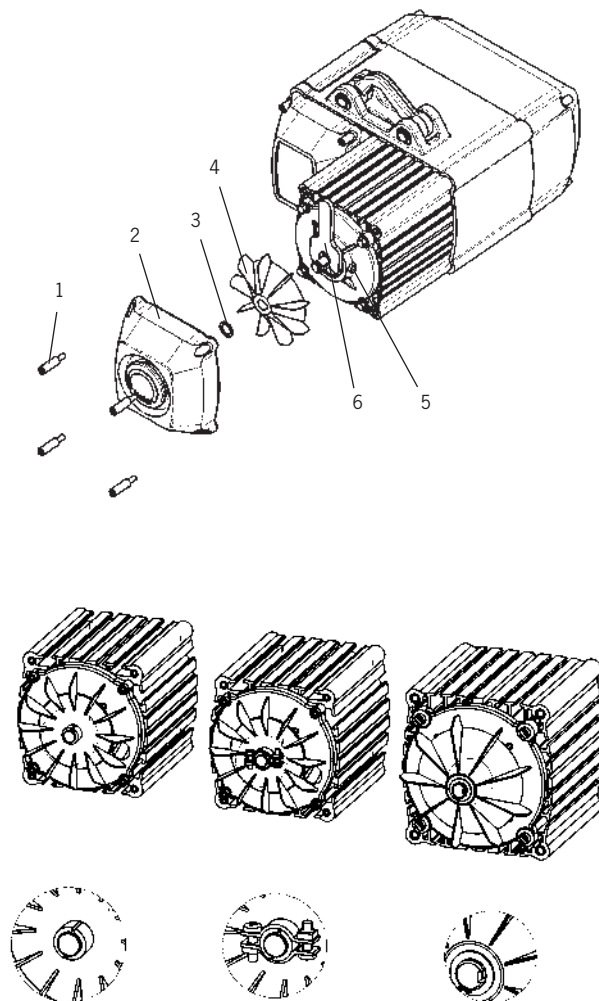

Maintenance Of Gearbox

The gearbox is maintenance-free.

Motor

The motor is maintenance-free under normal conditions, and it does not require any special inspection. Under more difficult conditions, make sure that sufficient volume of air is provided to the motor at all times. For this, the unit must be regularly cleaned.

Electromagnetic brake

Maintenance of the disc brake is limited to checking the nominal air way (disk brake air gap).

The disc brake air gap should be between 0,15 and 0,30 mm. This guarantees short response times and low noise emission. The brake must be replaced if the wear of the brake lining has aggravated to such an extent that the max. permissible air gap of the brake is reached:

The following dimensions must be observed for the air passage:

- Measure the SLü air passage between anchor disk and magnet section with a feeler gauge.
- Compare the measured air passage with the maximum permissible air passage (for max. SLü, see Tab. 5).
- If necessary, replace the brake.

ATTENTION: Do not allow the brake friction pads to come in contact with lubricants, etc.

ATTENTION: While checking the air passage, the motor should be switched off and the unit should be without load.

Modell	Lüftweg / Air Gap / L'Entrefer + 0,1 SLü [mm]		Bremsen / Brake / Frein [Typ / Type / Type]
	nom.	max.	
CPV/F 2-8, CPV/F 5-4	0,15	0,4	BFK 457 - 05
CPV/F 2-20, CPV/F 5-8, CPV/F 10-4 ¹	0,2	0,4	BFK 457 - 06
CPV/F 10-8, CPV/F 20-4, CPV/F 10-4 ² , CPV/F 20-2	0,2	0,6	BFK 457 - 08
CPV/F 5-20	0,2	0,7	BFK 457 - 10
CPV/F 25-8, CPV/F 50-4	0,3	0,8	BFK 457 - 12

¹) 400V/3Ph/50Hz 2-strang ²) 230V/1Ph/50Hz 1-strang

Dismantling the electromagnetic brake

ATTENTION: The unit must be tension-free!

- Dismantle the hood (control) (item 2). To do this, loosen the four cylinder bolts (item 1).
- Dismantle the transformer or contactor control plate (item 3) (only for CPV/F 2-20 til CPV/F 20-4). For this, loosen the three screws.
- Detach the Allen screws (item 4) of the brake and pull the brake (item 5) out (detach the control wire from the circuit board resp. from the connector).
- After replacing the spring action brake, check the nominal load.

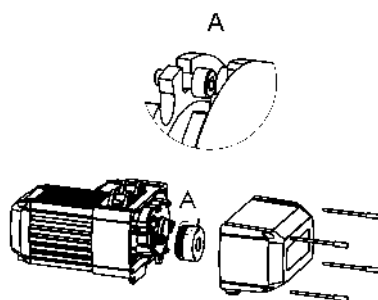

CPV/F2-8; CPV/F5-4

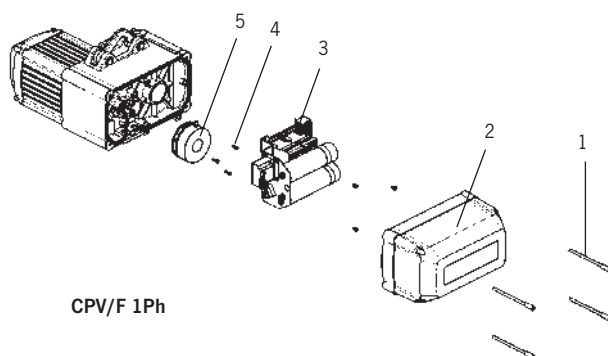

CPV/F 1Ph

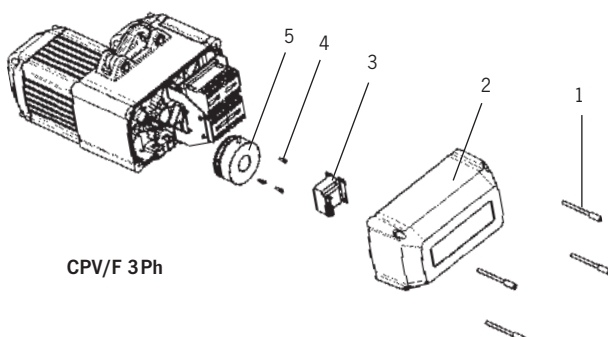

CPV/F 3Ph

Electric Chain Hoist In General

In particular check following parts:

- Threaded connections in general
- Chain container (optional)

Check all nuts, screws and locking devices for tightness.

- Ensure the chain container is securely fastened. Check for cracks or wear.
 - Suspension bolt (Connection between hoist and suspension bracket resp. trolley)
- Check for cracks or wear. Ensure all safety devices are in place and secure.

Repairs may only be carried out by authorized specialist workshops that use original Yale spare parts.

CMCO Industrial Products does not accept liability for damages resulting from the use of non-original parts or alterations and modifications made to the devices delivered by CMCO Industrial Products.

What is more, CMCO Industrial Products GmbH does not accept any liability and warranty for damages and operational faults that occur due to the non-observance of this operating instructions manual.

TRANSPORT, STORAGE, DECOMMISSIONING AND DISPOSAL**Observe the following for transporting the unit:**

- Do not drop or throw the unit, always deposit it carefully.
- Load and hand chains (only for models with reel trolley) must be transported in such a way that knotting and formation of loops are avoided.
- Do not bend control switch cables and power supply cables.
- Use suitable transport means. These depend on the local conditions.

Observe the following for storing or temporarily taking the unit out of service:

- Store the unit at a clean and dry place where there is no frost.
 - Protect the unit (including all attached parts) against contamination, humidity and damage by means of a suitable cover.
 - Protect hooks against corrosion.
 - A light lubricant film should be applied to the chain(s).
 - Do not bend control switch cables and power supply cables.
 - In the case of models with an integral trolley, grease the load bar as well as both threaded rods to protect them against corrosion.
- If the unit is to be used again after it has been taken out of service, it must first be inspected again by a competent person.

DISPOSAL:

After taking the unit out of service, recycle or dispose of the parts of the unit in accordance with the legal regulations.

Further information and operating instructions for download can be found at www.cmco.eu!