



## AV Surround Receiver NR1510



[Click here!](#)

### On-line service parts list

<http://dmedia.dmglobal.com/Document/DocumentDetails/25778>

[ONLINE PARTS LIST \(P5\)](#)

### WEB owner's manual

NA: <http://manuals.marantz.com/NR1510/NA/EN/index.php>

EU: <http://manuals.marantz.com/NR1510/EU/EN/index.php>

AP: <http://manuals.marantz.com/NR1510/AP/ZH/index.php>

Upload is planned for the time of a future press release.

## BEFORE SERVICING THIS UNIT

### ELECTRICAL

### MECHANICAL

### REPAIR INFORMATION

### UPDATING

- For purposes of improvement, specifications and design are subject to change without notice.
- Please use this service manual when referring to the operating instructions without fail.
- Some illustrations used in this service manual are slightly different from the actual product.

**Confidential**

# BEFORE SERVICING THIS UNIT

## SAFETY PRECAUTIONS

## NOTE FOR SCHEMATIC DIAGRAM

## HANDLING THE SEMICONDUCTOR AND OPTICS

## ONLINE PARTS LIST

[Accessing the Parts List](#)

[Searching Part Numbers or Ref. Numbers](#)

[NOTE FOR PARTS LIST](#)

## SERIAL NUMBER

[Serial Number Organization](#)

[SKU Code of this Unit](#)

## POST-SERVICE PRECAUTIONS

[Initializing this Unit](#)

[JIG FOR SERVICING](#)

# SAFETY PRECAUTIONS

The following items should be checked for continued protection of the customer and the service technician.

## Leakage current check

Before returning the set to the customer, be sure to carry out either (1) a leakage current check or (2) a line to chassis resistance check. If the leakage current exceeds 0.5 milliamps, or if the resistance from chassis to either side of the power cord is less than 460 kohms, the set is defective.

Be sure to test for leakage current with the AC plug in both polarities, in addition, when the set's power is in each state (on, off and standby mode), if applicable.

### CAUTION

**Please heed the following cautions and instructions during servicing and inspection.**

#### ⊙ Heed the cautions!

Cautions which are delicate in particular for servicing are labeled on the cabinets, the parts and the chassis, etc. Be sure to heed these cautions and the cautions described in the handling instructions.

#### ⊙ Cautions concerning electric shock!

- (1) An AC voltage is impressed on this set, so if you touch internal metal parts when the set is energized, you may get an electric shock. Avoid getting an electric shock, by using an isolating transformer and wearing gloves when servicing while the set is energized, or by unplugging the power cord when replacing parts, for example.
- (2) There are high voltage parts inside. Handle with extra care when the set is energized.

#### ⊙ Caution concerning disassembly and assembly!

Through great care is taken when parts were manufactured from sheet metal, there may be burrs on the edges of parts. The burrs could cause injury if fingers are moved across them in some rare cases. Wear gloves to protect your hands.

#### ⊙ Use only designated parts!

The set's parts have specific safety properties (fire resistance, voltage resistance, etc.). Be sure to use parts which have the same properties for replacement. The burrs have the same properties. In particular, for the important safety parts that are indicated by the  $\triangle$  mark on schematic diagrams and parts lists, be sure to use the designated parts.

#### ⊙ Be sure to mount parts and arrange the wires as they were originally placed!

For safety reasons, some parts use tapes, tubes or other insulating materials, and some parts are mounted away from the surface of printed circuit boards. Care should also be taken with the positions of the wires by arranging them and using clamps to keep them away from heating and high voltage parts, so be sure to set everything back as it was originally placed.

#### ⊙ Make a safety check after servicing!

Check that all screws, parts and wires removed or disconnected when servicing have been put back in their original positions, check that no serviced parts have deteriorated the area around. Then make an insulation check on the external metal connectors and between the blades of the power plug. And otherwise check that safety is ensured.

(Insulation check procedure)

Unplug the power cord from the power outlet, disconnect the antenna, plugs, etc., and on the power.

Using a 500V insulation resistance tester, check that the insulation resistance value between the inplug and the externally exposed metal parts (antenna terminal, headphones terminal, input terminal, etc.) is 1M  $\Omega$  or greater. If it is less, the set must be inspected and repaired.

### CAUTION

**Concerning important safety parts**

Many of the electric and the structural parts used in the set have special safety properties. In most cases these properties are difficult to distinguish by sight, and the use of replacement parts with higher ratings (rated power and withstand voltage) does not necessarily guarantee that safety performance will be preserved. Parts with safety properties are indicated as shown below on the wiring diagrams and the parts list in this service manual. Be sure to replace them with the parts which have the designated part number.

- (1) Schematic diagrams Indicated by the  $\triangle$  mark.
- (2) Parts lists Indicated by the  $\triangle$  mark.

The use of parts other than the designated parts could cause electric shocks, fires or other dangerous situations.

## NOTE FOR SCHEMATIC DIAGRAM

### WARNING:

Parts indicated by the  $\triangle$  mark have critical characteristics. Use ONLY replacement parts recommended by the manufacturer.

### CAUTION:

Before returning the set to the customer, be sure to carry out either (1) a leakage current check or (2) a line to chassis resistance check. If the leakage current exceeds 0.5 milliamps, or if the resistance from chassis to either side of the power cord is less than 460 kohms, the set is defective.

### WARNING:

DO NOT return the set to the customer unless the problem is identified and remedied.

### NOTICE:

- (1) ALL RESISTANCE VALUES IN OHM. k=1,000 OHM / M=1,000,000 OHM
- (2) ALL CAPACITANCE VALUES ARE EXPRESSED IN MICRO FARAD, UNLESS OTHERWISE INDICATED. P INDICATES MICRO-MICRO FARAD. N INDICATES NANO FARAD.
- (3) EACH VOLTAGE AND CURRENT ARE MEASURED AT NO SIGNAL INPUT CONDITION.
- (4) CIRCUIT AND PARTS ARE SUBJECT TO CHANGE WITHOUT PRIOR NOTICE.

## HANDLING THE SEMICONDUCTOR AND OPTICS

Electrostatic breakdown of the semi-conductors or optical pickup may occur due to a potential difference caused by electrostatic charge during unpacking or repair work.

### 1. Ground for Human Body

Be sure to wear a grounding band (1 M ohm) that is properly grounded to remove any static electricity that may be charged on the body.

### 2. Ground for Workbench

Be sure to place a conductive sheet or copper plate with proper grounding (1 M ohm) on the workbench or other surface, where the semi-conductors are to be placed. Because the static electricity charge on clothing will not escape through the body grounding band, be careful to avoid contacting semi-conductors with your clothing

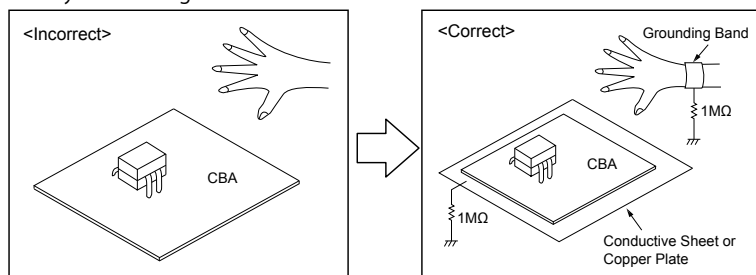

## Accessing the Parts List

- Access from the Service Manual
  - Click the URL link on the cover of the service manual.  
Examples of display

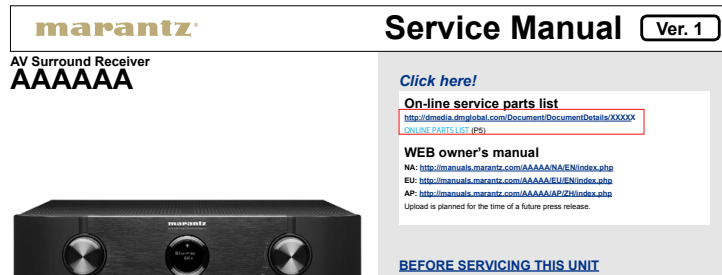

**NOTE:** If the web browser does not open automatically, copy the URL and paste it into the address bar of the web browser and then press Enter.

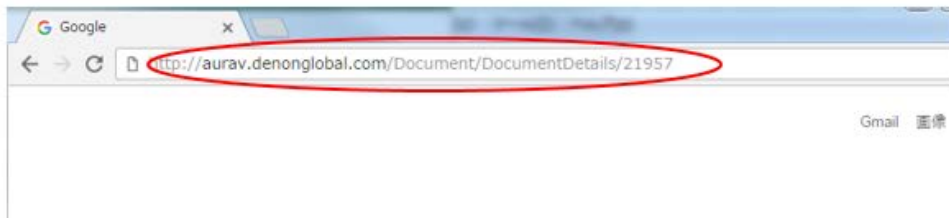

- Accessing the Part List from the Model Asset Screen.
  - Display Model Asset from New SDI.
  - Click the section displayed as ▼ Link to Part Lists under the model name.

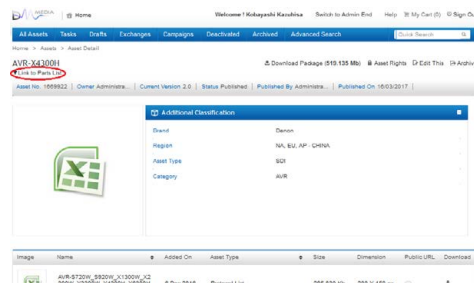

**NOTE:** If the ▼ Link to Parts List section is not displayed, download the parts table from the Asset list.

## Searching Part Numbers or Ref. Numbers

You can search a Parts List for part numbers or Ref. numbers.

- Enter the part number or Ref. number in the search window of the Parts List, and press the search button.
- The search results are displayed.  
The name of the sheet in which the search part is used and the part's line are displayed.

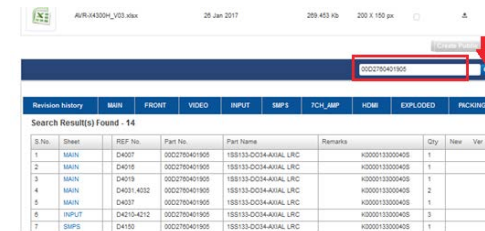

- Next, click the "Sheet" section of the search results.

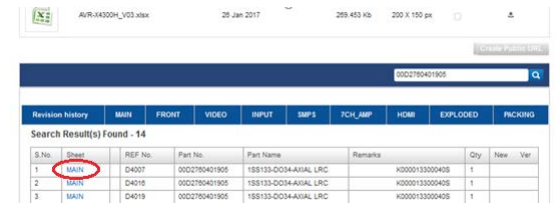

## NOTE FOR PARTS LIST

- Parts indicated by "nsp" on this table cannot be supplied.
  - When ordering a part, make a clear distinction between "1" and "l" (i) to avoid mis-supplying.
  - A part ordered without specifying its part number can not be supplied.
  - Part indicated by "@" mark is not illustrated in the exploded and packaging view.
- WARNING:** Parts indicated by the ⚠ mark have critical characteristics. Use ONLY replacement parts recommended by the manufacturer.

# SERIAL NUMBER

## Serial Number Organization

The 14-digit serial number that contains the code of the manufacturing plant and the manufacturing date.

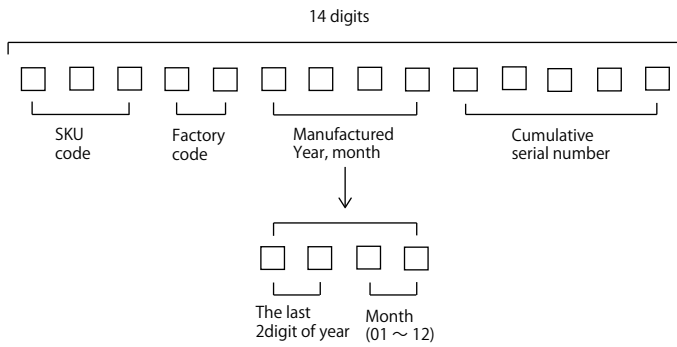

## SKU Code of this Unit

Product SKU	SKU Code
NR1510/U1B	BHU
NR1510/N1B	BHV
NR1510/N1SG	BHW
NR1510/K1B	BHX

## POST-SERVICE PRECAUTIONS

### Initializing this Unit

Make sure to initialize this unit after replacing the microcomputer or any peripheral equipment, or the digital PCB.

1. Press the power button to turn off the power.
2. While holding down buttons "**TUNER PRESET CH +**" and "**INTERNET RADIO**" simultaneously, press the power button to turn on the power.
3. Release the buttons after confirming that the display flashes at 1-second intervals.
  - \* The unit is initialized.
  - Use network initialization mode to initialize the network related settings.

**NOTE :**

- If the unit fails to enter the service mode in step 3, repeat the procedure from step 1.
- Initializing the device restores the customized settings to the factory settings. Write down your settings in advance and reconfigure the settings after initialization.

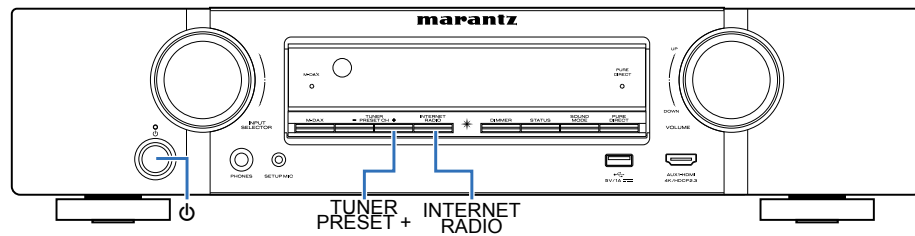

### JIG FOR SERVICING

Use the following jigs (extension cable kit) when repairing the PCBs.  
Order with your dealer for the jigs your dealer if necessary.

8U-110084S : EXTENSION UNIT KIT : 1 Set  
(See [JIG FOR SERVICING](#))

# ELECTRICAL

## SCHEMATIC DIAGRAMS

SCH01 eARC  
SCH02 MN864787  
SCH03 MN864788  
SCH04 ADV7623  
SCH05 NET PHY  
SCH06 CPU  
SCH07 CPU LEVEL CHG  
SCH08 DSP  
SCH09 DIR A.PLD  
SCH10 MAIN DAC  
SCH11 D.SUPPLY  
SCH12 DIGITAL CNT  
SCH13 SPK  
SCH14 REG CNT  
SCH15 SIDE CNT  
SCH16 INPUT  
SCH17 VIDEO  
SCH18 TUNER  
SCH19 F-HDMI  
SCH20 FRONT  
SCH21 AMP1  
SCH22 AMP2  
SCH23 SMPS  
SCH24 REG  
SCH25 FRONT CNT

## PRINTED CIRCUIT BOARDS

DIGITAL, F HDMI  
AV  
SPK, REG CNT, HDMI GUIDE A, HDMI GUIDE  
AMP, FRONT, MC HP, USB  
REG, GUIDE L, FRONT FFC GUID, FRONT CNT, SMPS, SIDE CNT

## LEVEL DIAGRAM

FRONT ch  
CENTER ch  
SUBWOOFER ch  
SURROUND ch  
LEGO ADC

## BLOCK DIAGRAM

ANALOG AUDIO DIAGRAM  
DIGITAL AUDIO DIAGRAM  
VIDEO DIAGRAM

## POWER DIAGRAM

## WIRING DIAGRAM

## SEMICONDUCTORS

1. IC's
2. FL DISPLAY
3. Remote Code Table



eARC

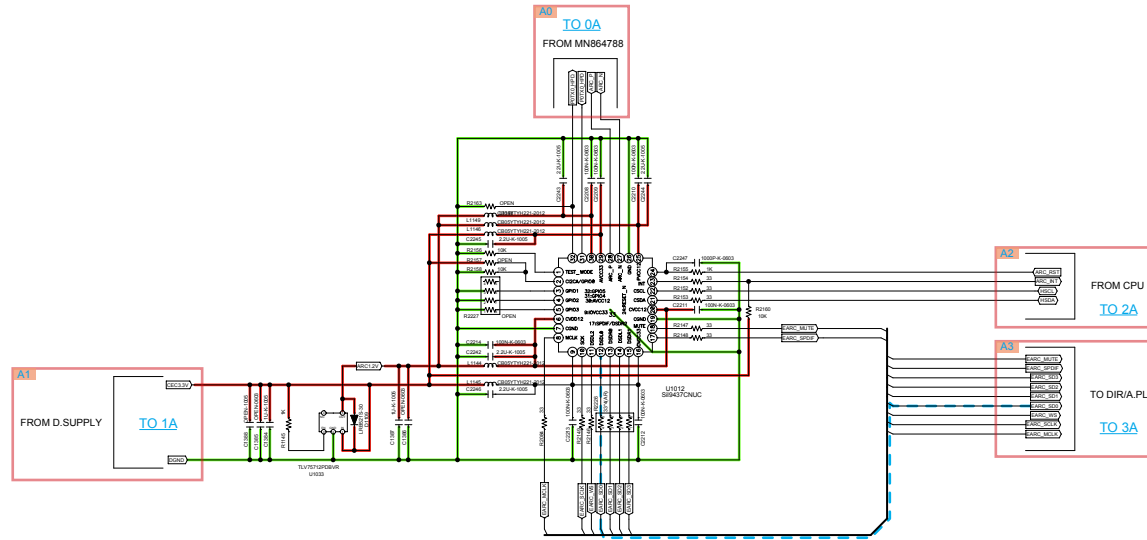

— GND LINE   
 — POWER+ LINE   
 — POWER- LINE   
 - - - ANALOG AUDIO   
 - - - DIGITAL AUDIO   
 - - - TMDS SIGNAL   
 - - - VIDEO SIGNAL   
 - - - COMPONENT(Y)   
 - - - STBY POWER

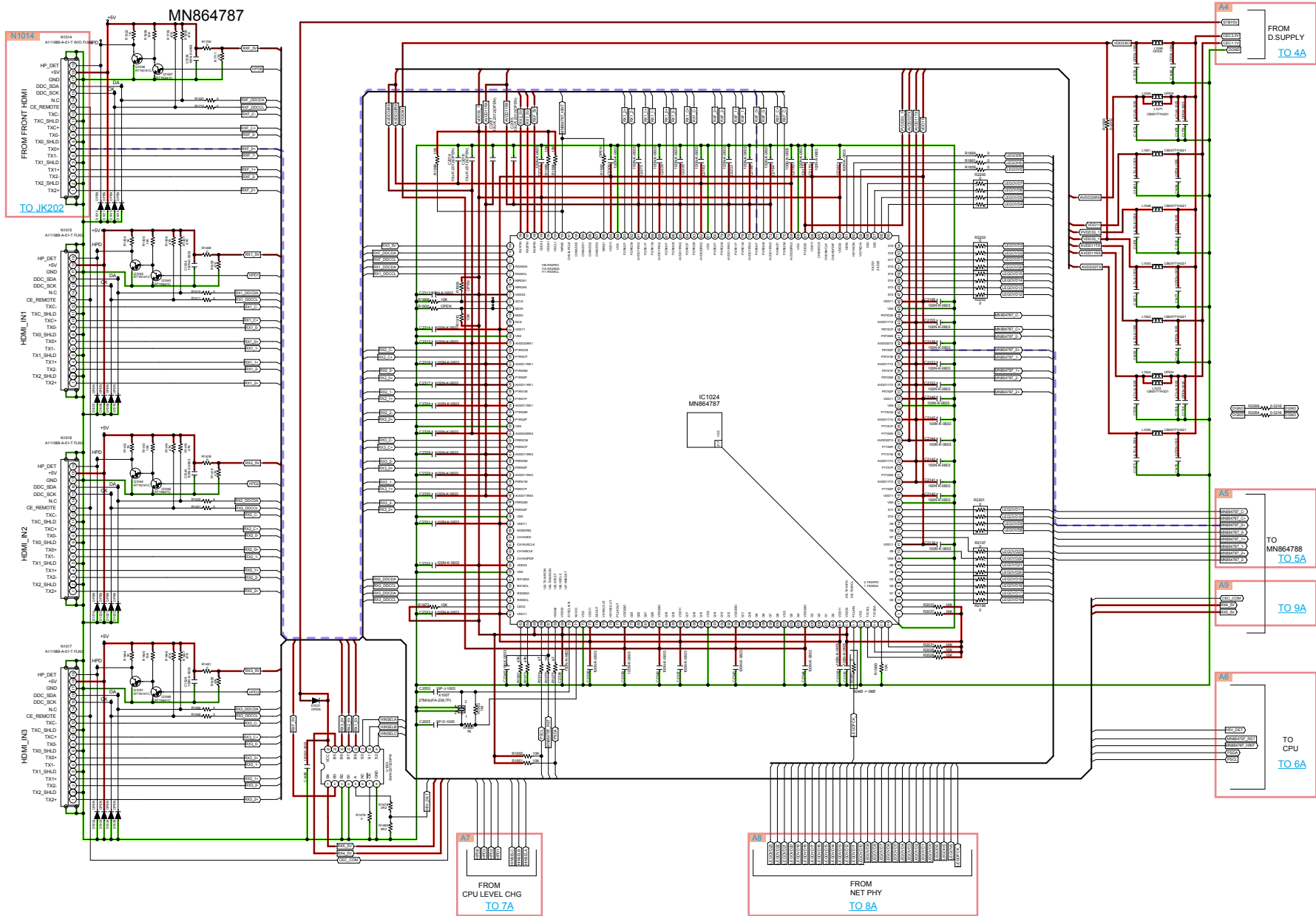

GND LINE    POWER+ LINE    POWER- LINE    ANALOG AUDIO    DIGITAL AUDIO    TMDS SIGNAL    VIDEO SIGNAL    COMPONENT(Y)    STBY POWER

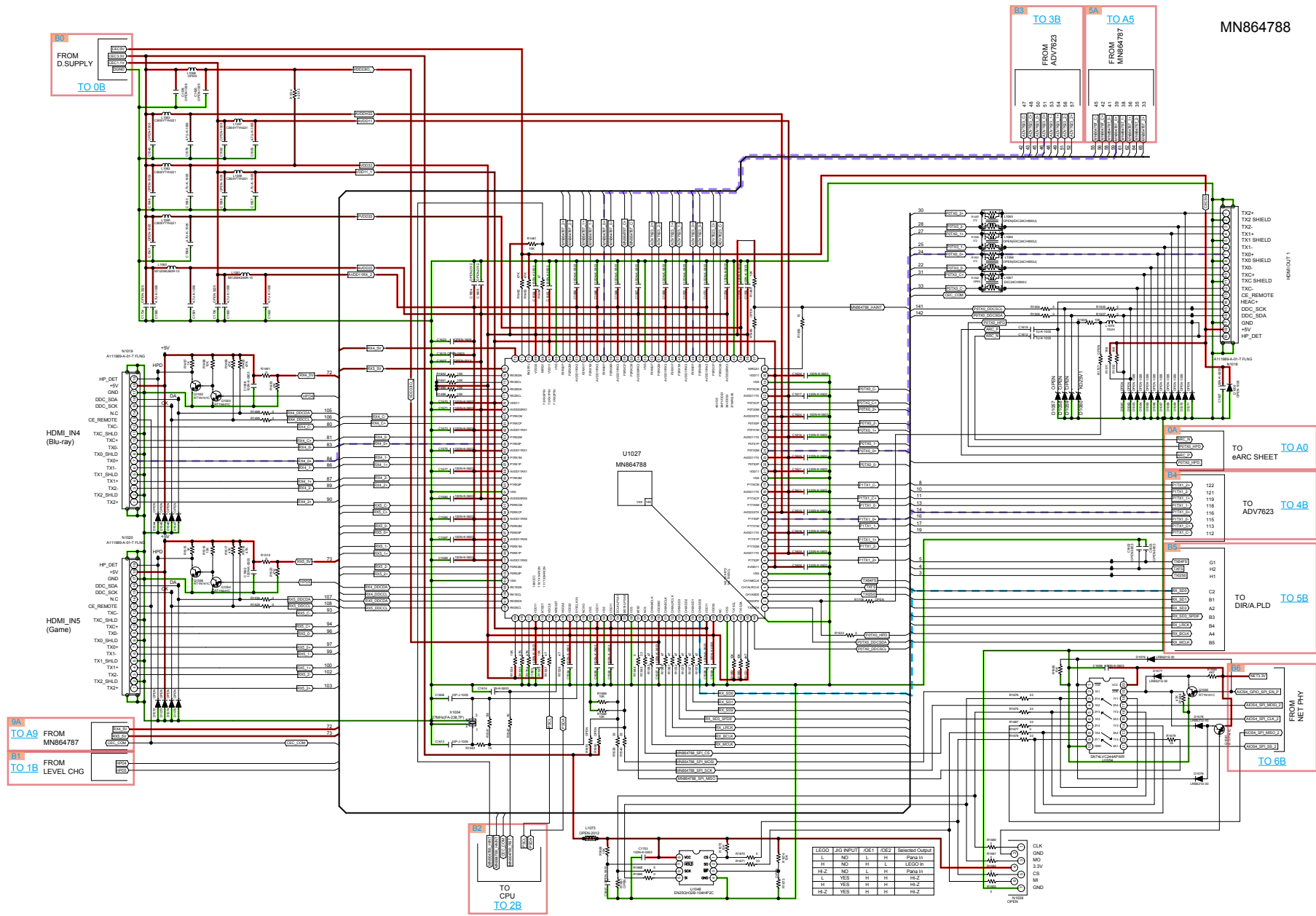

MN864788

Before Servicing  
This Unit

Electrical

Mechanical

Repair Information

Updating

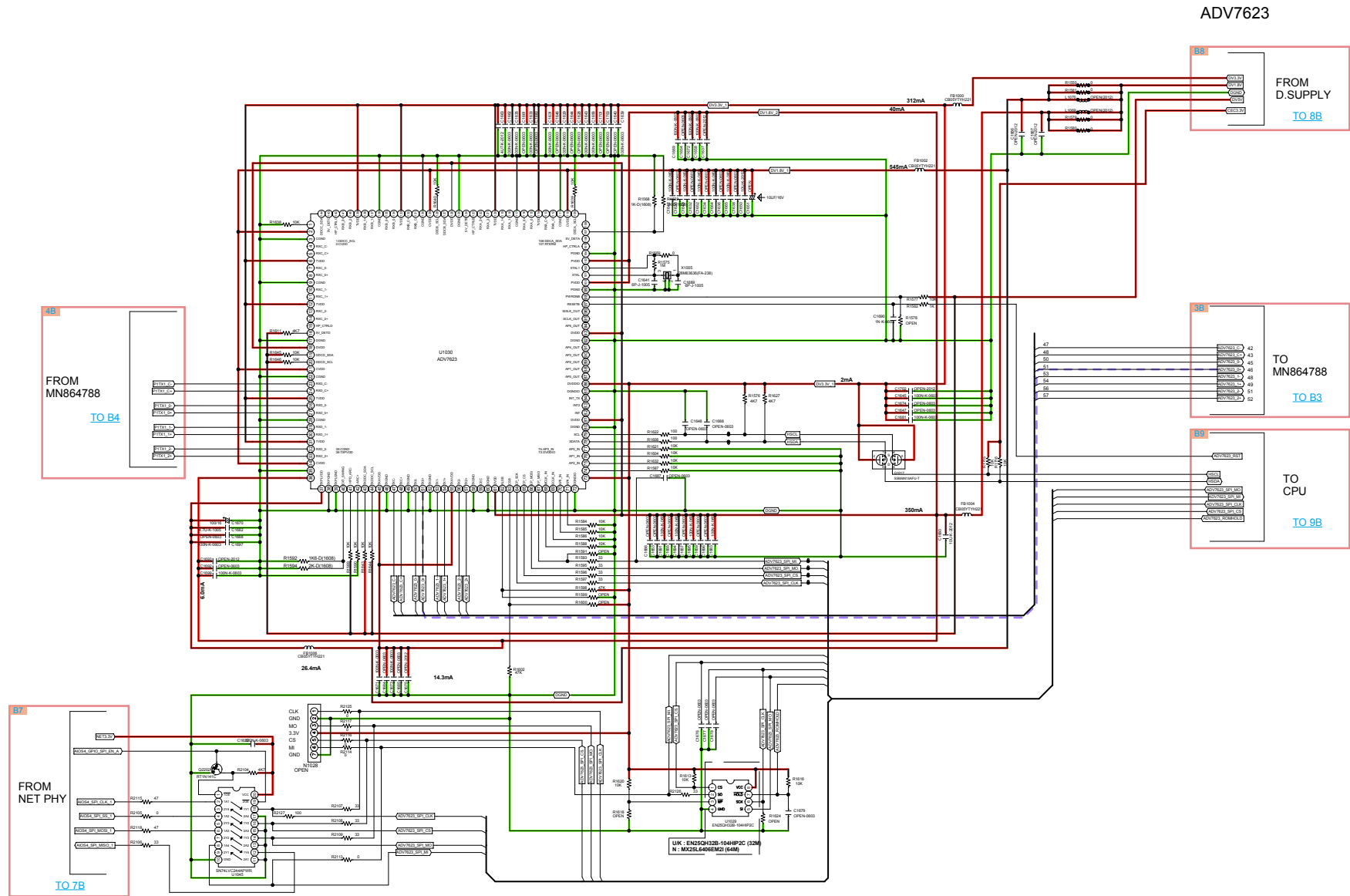

— GND LINE   
 — POWER+ LINE   
 — POWER- LINE   
 — ANALOG AUDIO   
 — DIGITAL AUDIO   
 — TMDS SIGNAL   
 — VIDEO SIGNAL   
 — COMPONENT(Y)   
 — STBY POWER

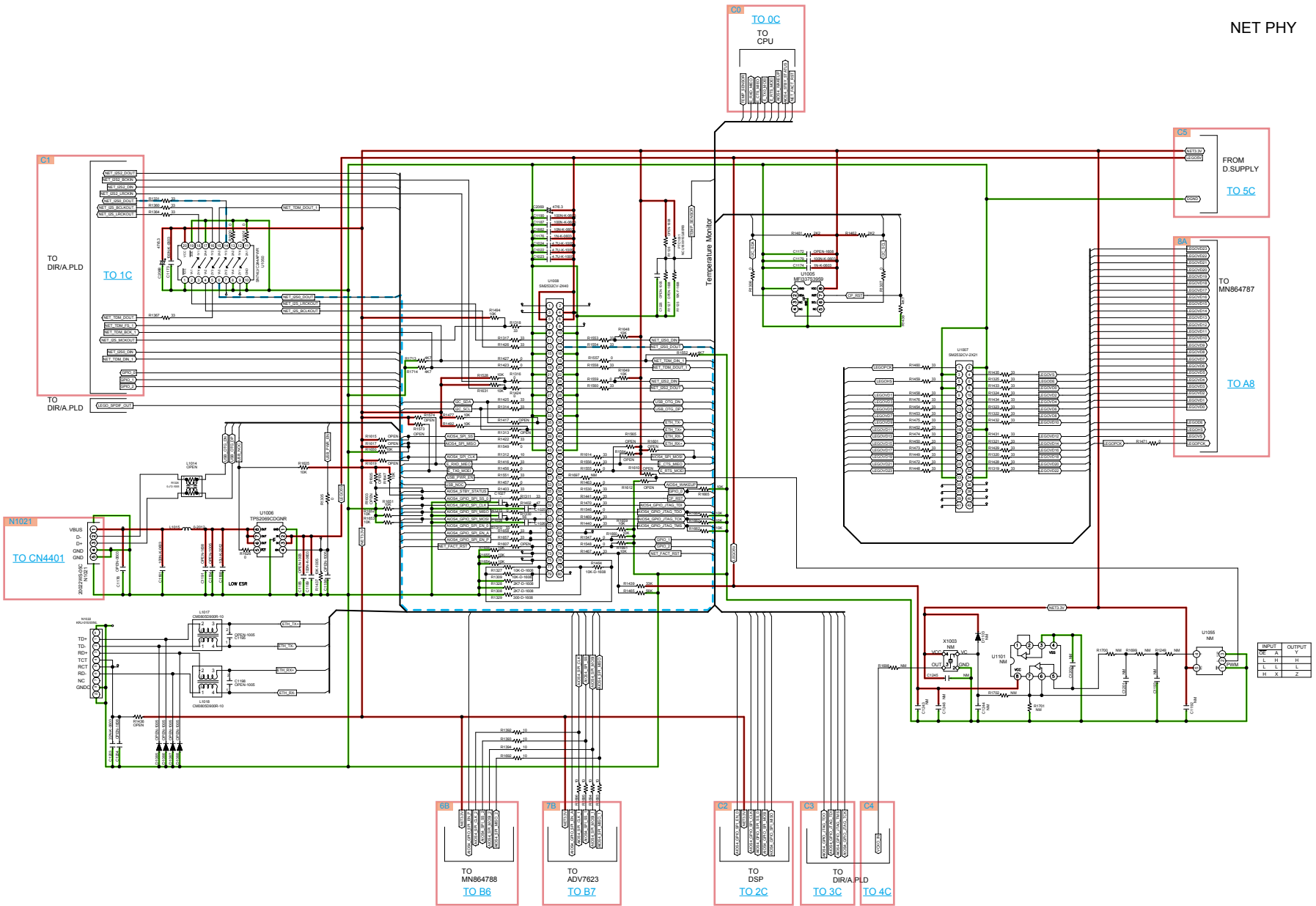

NET PHY

- 
 GND LINE
- 
 POWER+ LINE
- 
 POWER- LINE
- 
 ANALOG AUDIO
- 
 DIGITAL AUDIO
- 
 TMDS SIGNAL
- 
 VIDEO SIGNAL
- 
 COMPONENT(Y)
- 
 STBY POWER

Before Servicing  
This Unit

Electrical

Mechanical

Repair Information

Updating

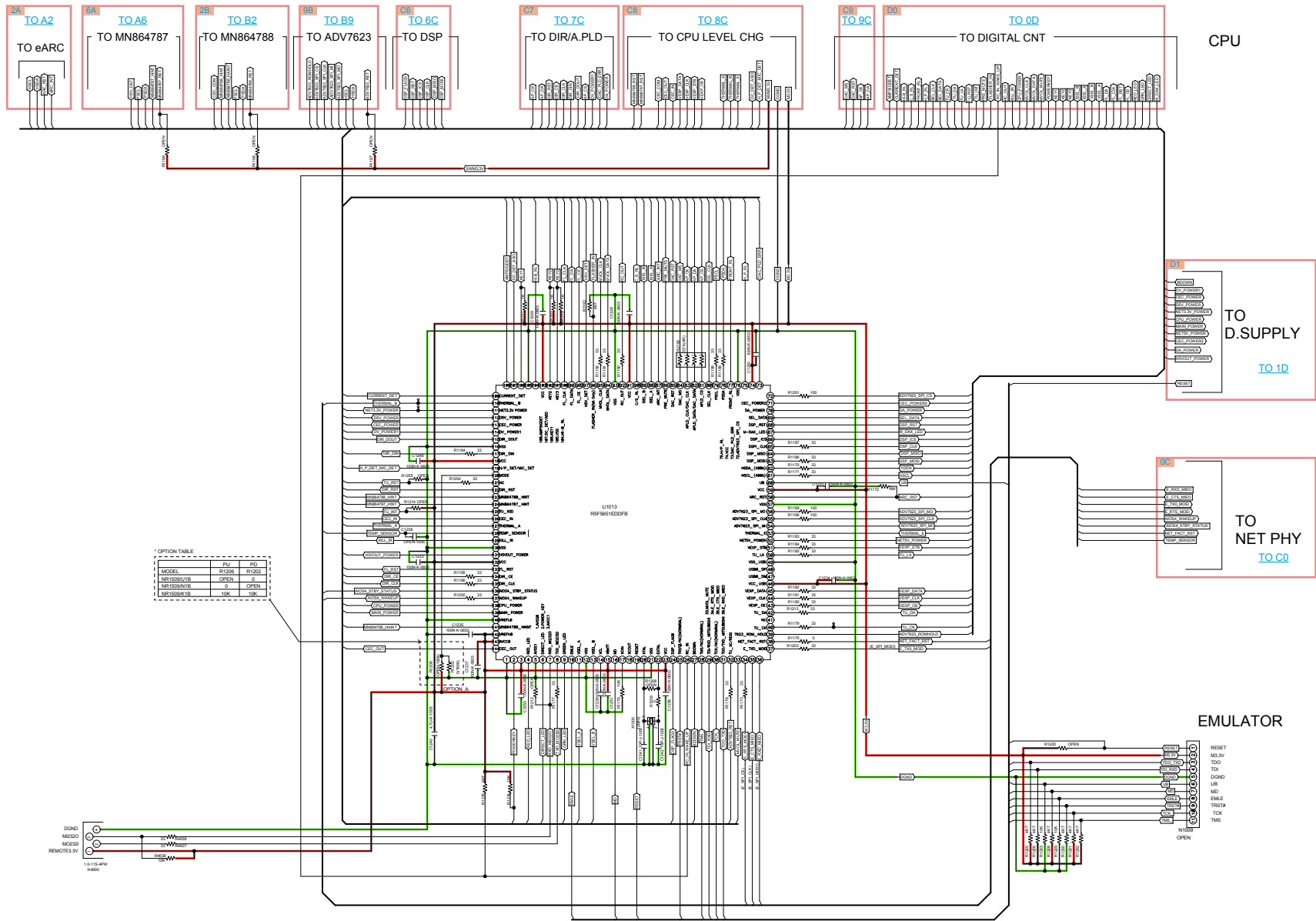

GND LINE    POWER+ LINE    POWER- LINE    ANALOG AUDIO    DIGITAL AUDIO    TMDS SIGNAL    VIDEO SIGNAL    COMPONENT(Y)    STBY POWER

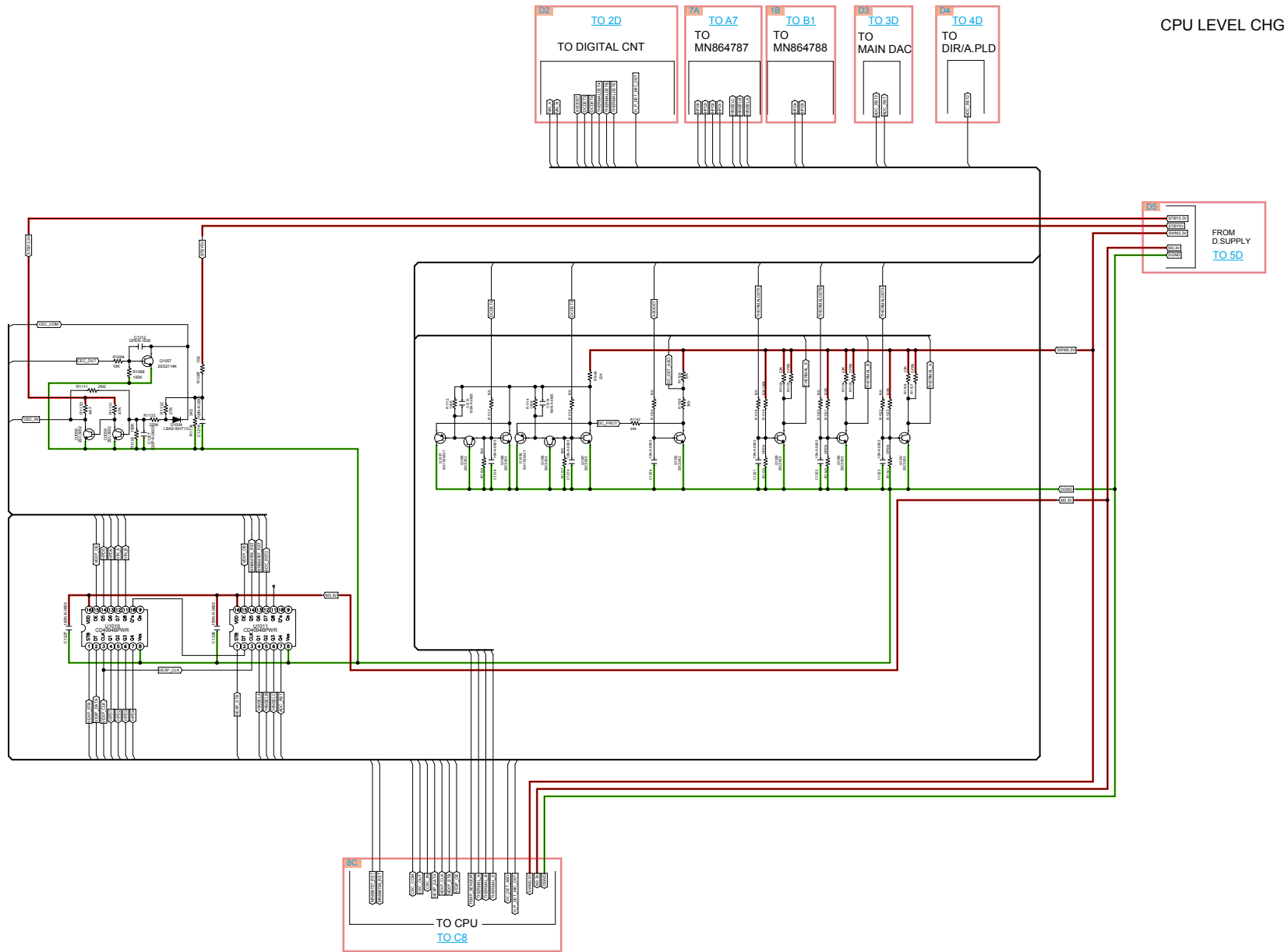

CPU LEVEL CHG

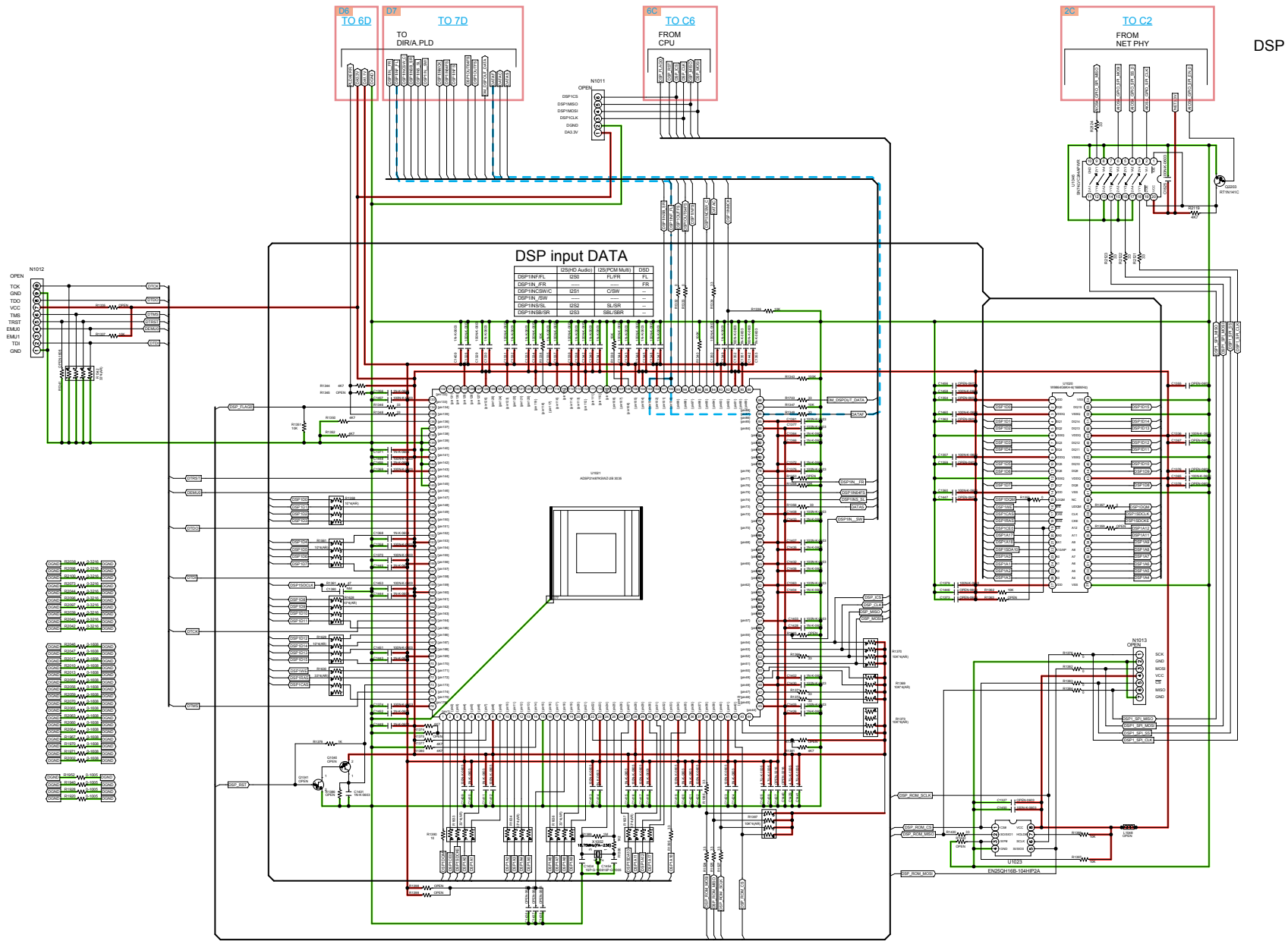

GND LINE    POWER+ LINE    POWER- LINE    ANALOG AUDIO    DIGITAL AUDIO    TMDS SIGNAL    VIDEO SIGNAL    COMPONENT(Y)    STBY POWER



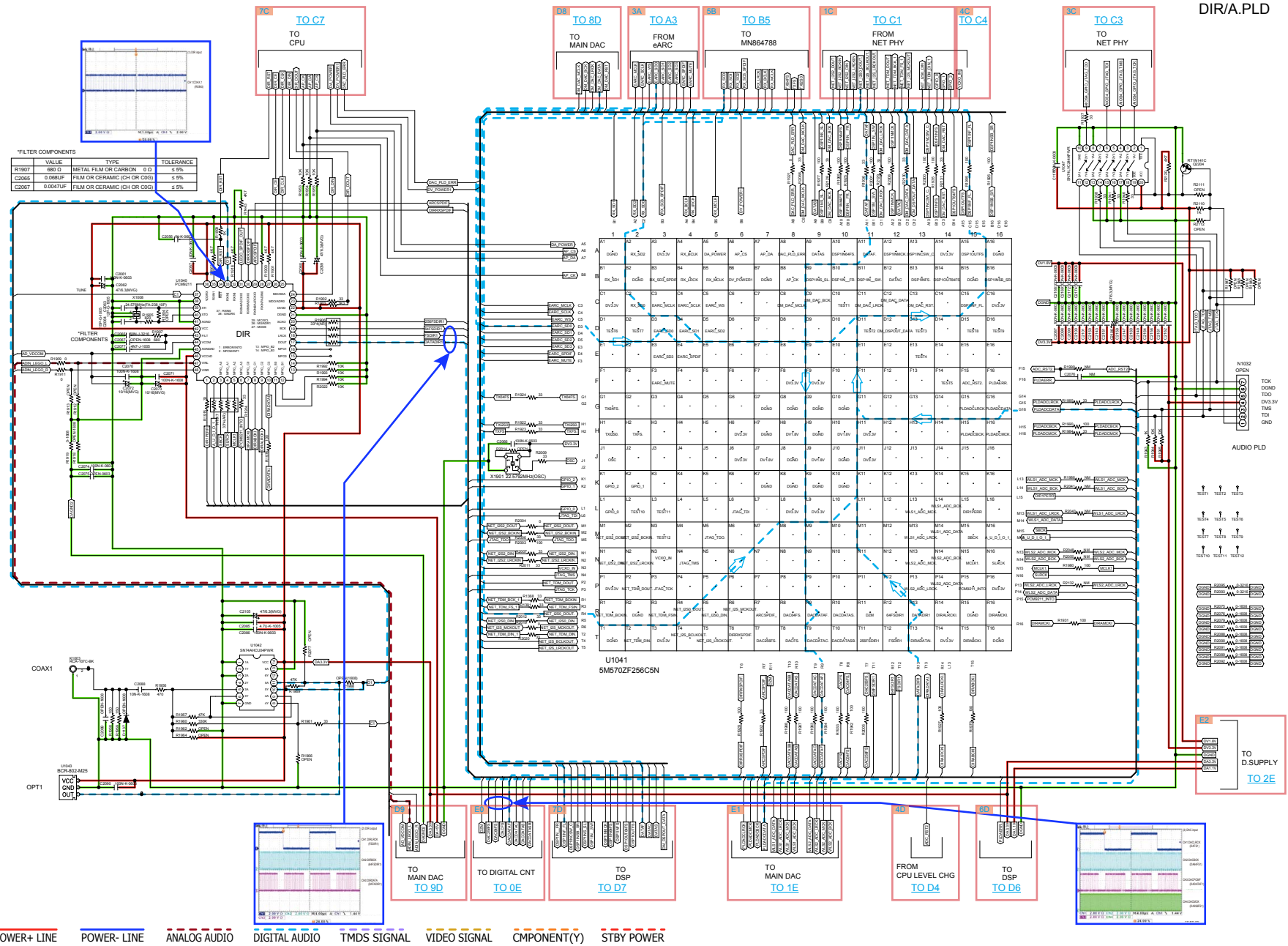

Before Servicing  
This Unit

Electrical

Mechanical

Repair Information

Updating

MAIN DAC

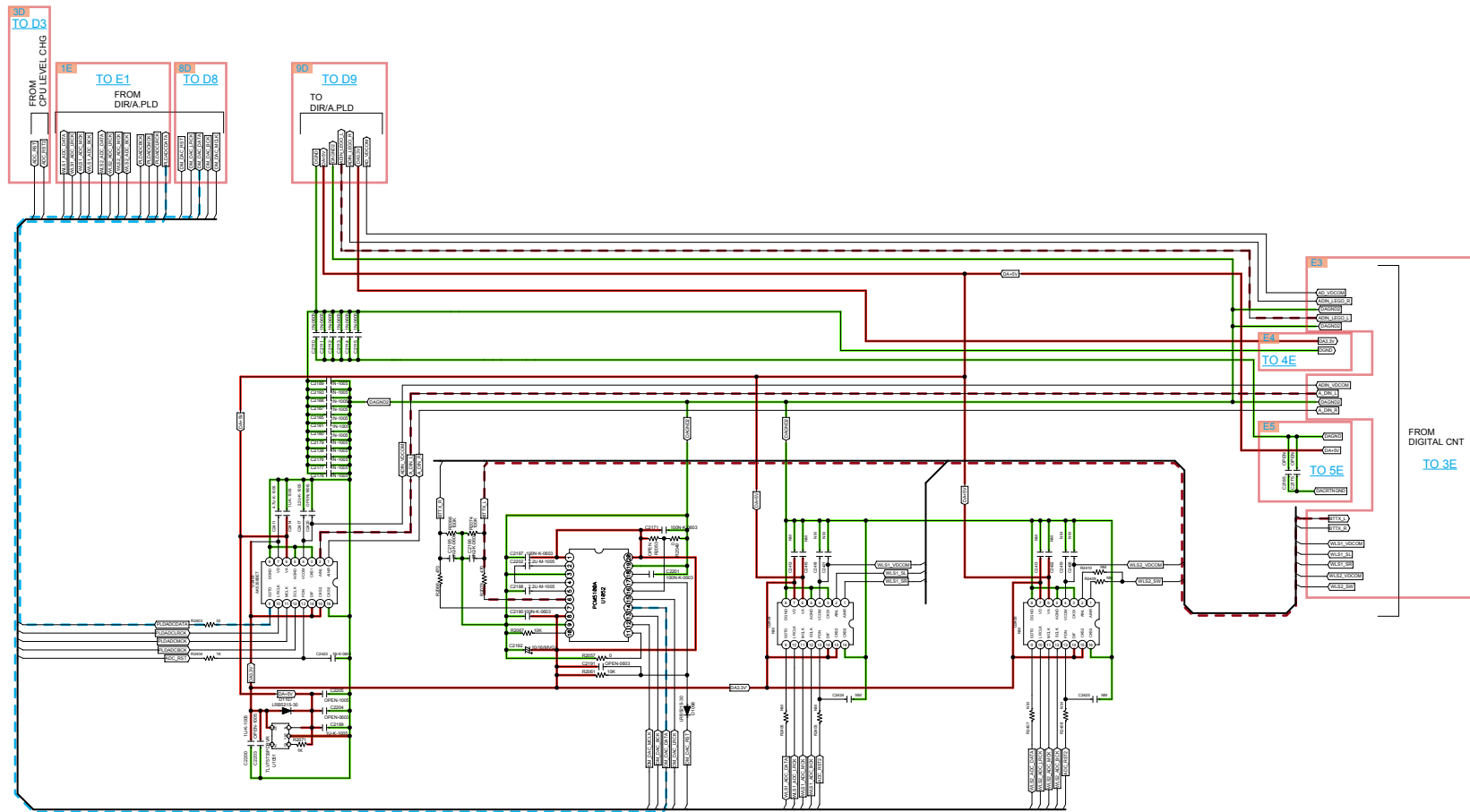

GND LINE    POWER+ LINE    POWER- LINE    ANALOG AUDIO    DIGITAL AUDIO    TMDS SIGNAL    VIDEO SIGNAL    COMPONENT(Y)    STBY POWER

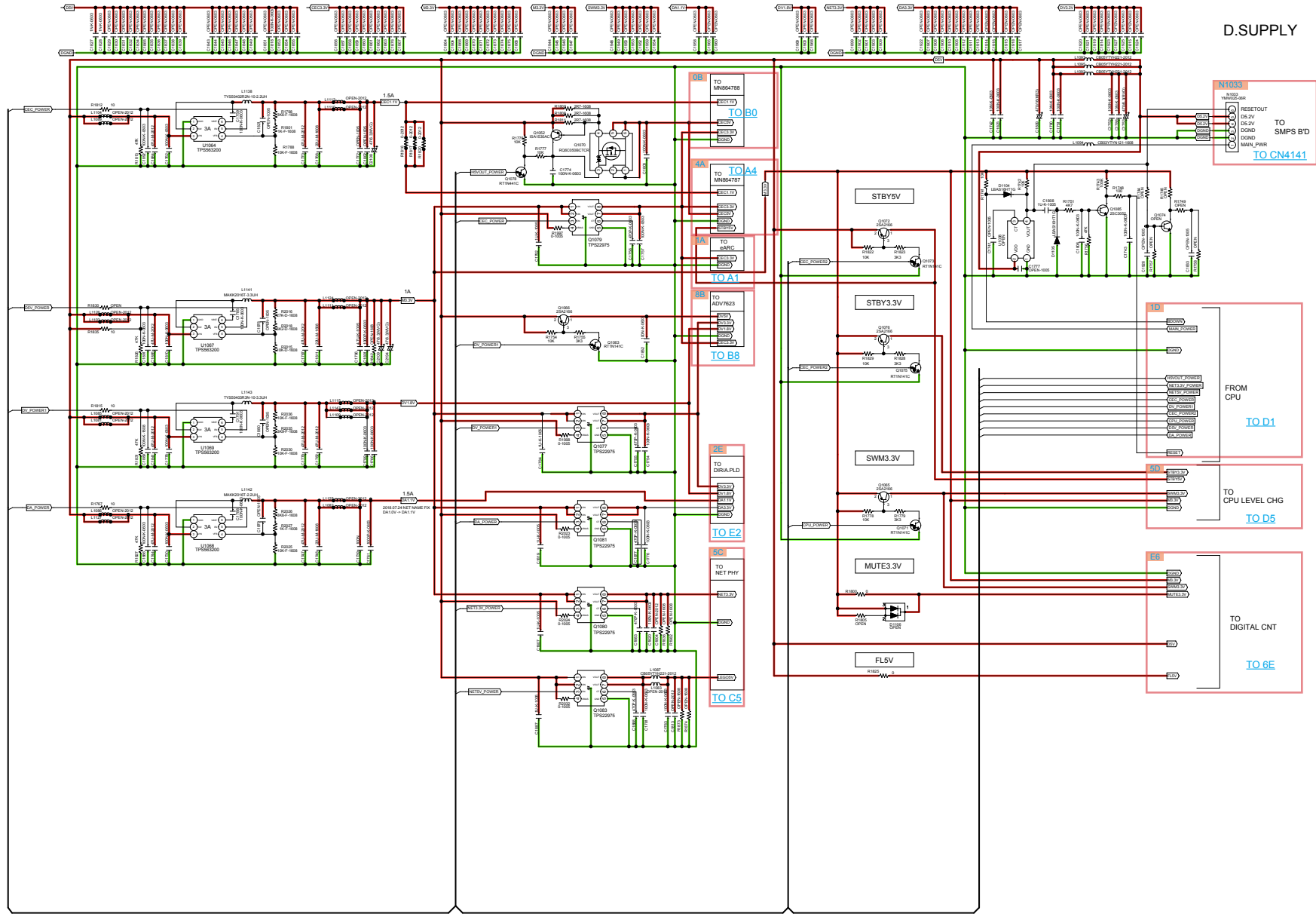

D.SUPPLY

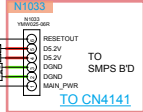

GND LINE    POWER+ LINE    POWER- LINE    ANALOG AUDIO    DIGITAL AUDIO    TMDS SIGNAL    VIDEO SIGNAL    COMPONENT(Y)    STBY POWER

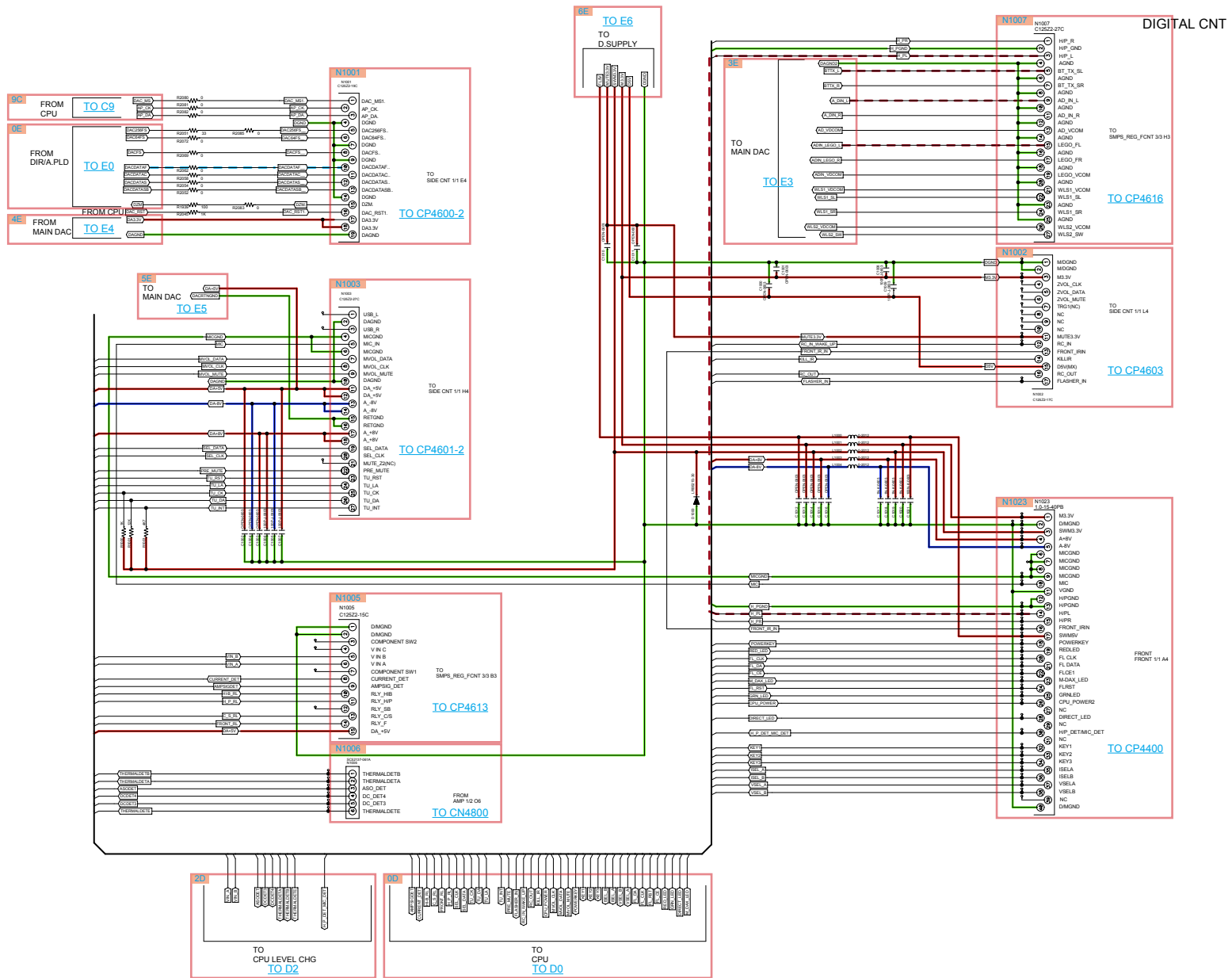

GND LINE    POWER+ LINE    POWER- LINE    ANALOG AUDIO    DIGITAL AUDIO    TMDS SIGNAL    VIDEO SIGNAL    COMPONENT(Y)    STBY POWER

SPK\_SCNT 1/2 MP

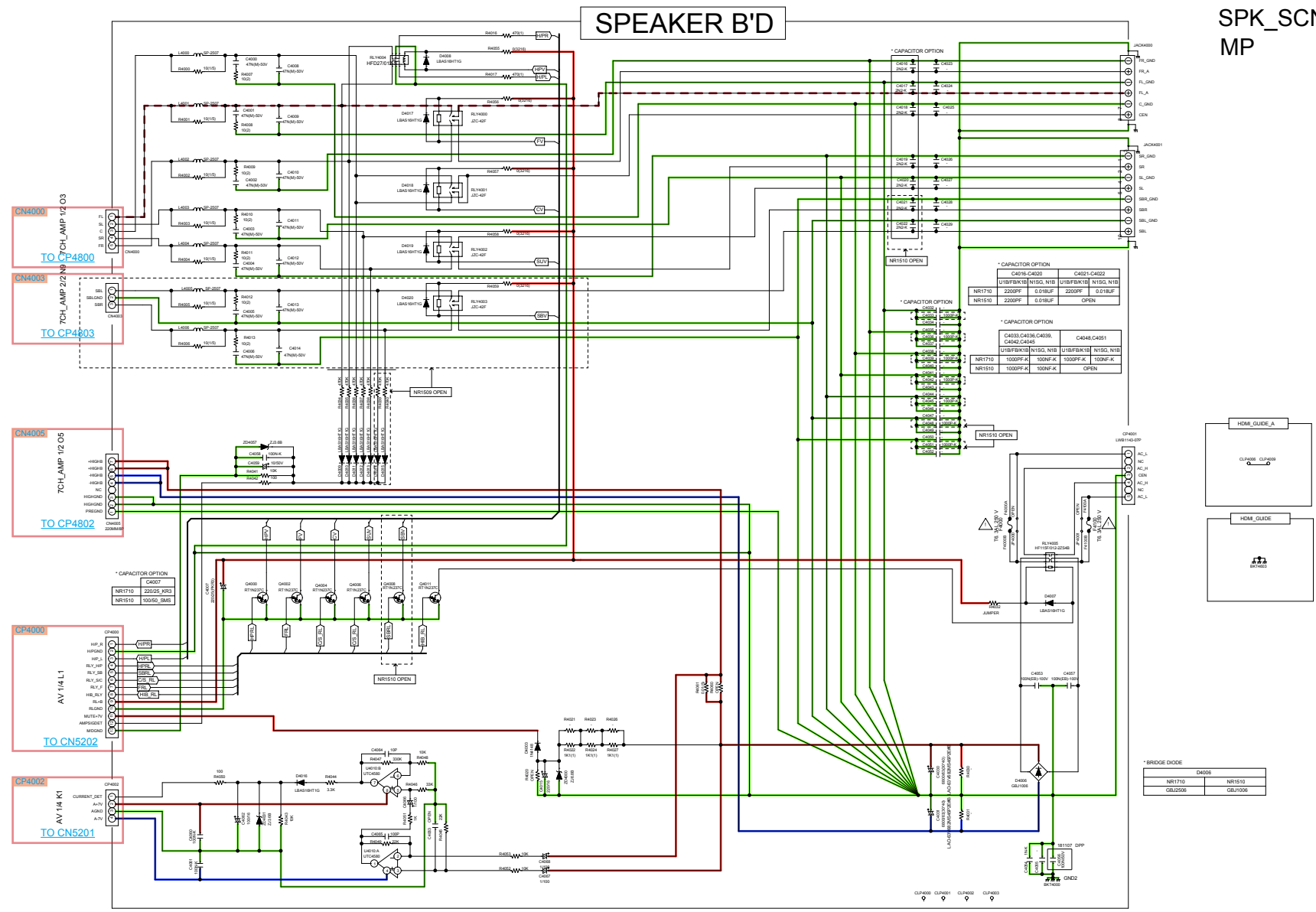

REG CNT

SPK\_REG CNT 2/2  
MP

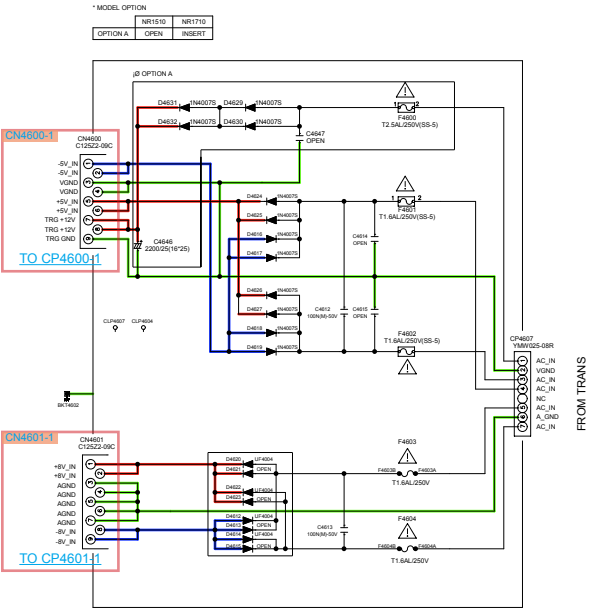

- GND LINE
- POWER+ LINE
- POWER- LINE
- ANALOG AUDIO
- DIGITAL AUDIO
- TMDS SIGNAL
- VIDEO SIGNAL
- COMPONENT(Y)
- STBY POWER

# SIDE CONNECTOR

SIDE CNT 1/1  
MP

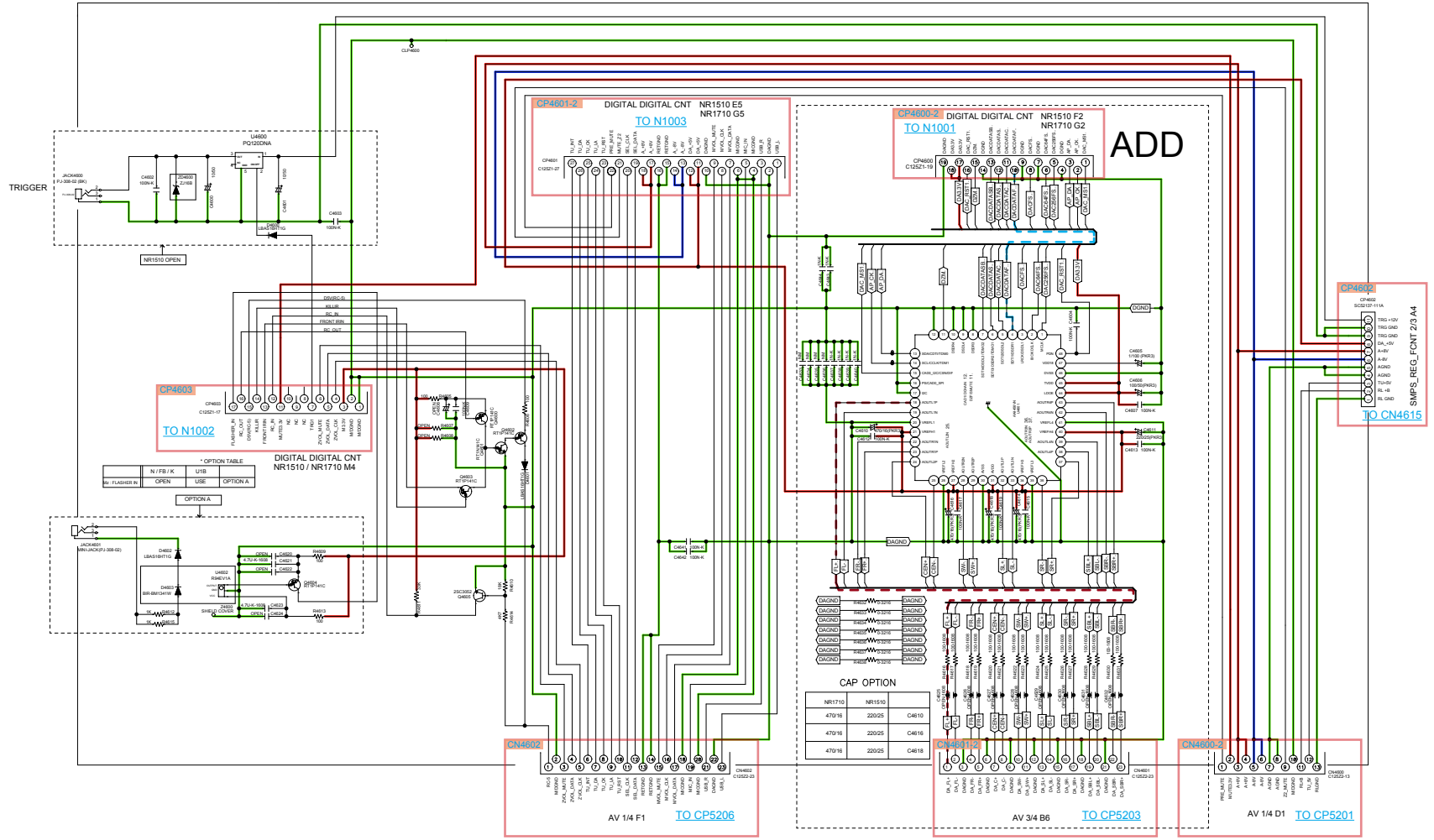

GND LINE    POWER+ LINE    POWER- LINE    ANALOG AUDIO    DIGITAL AUDIO    TMDS SIGNAL    VIDEO SIGNAL    COMPONENT(Y)    STBY POWER

# SCH16 INPUT

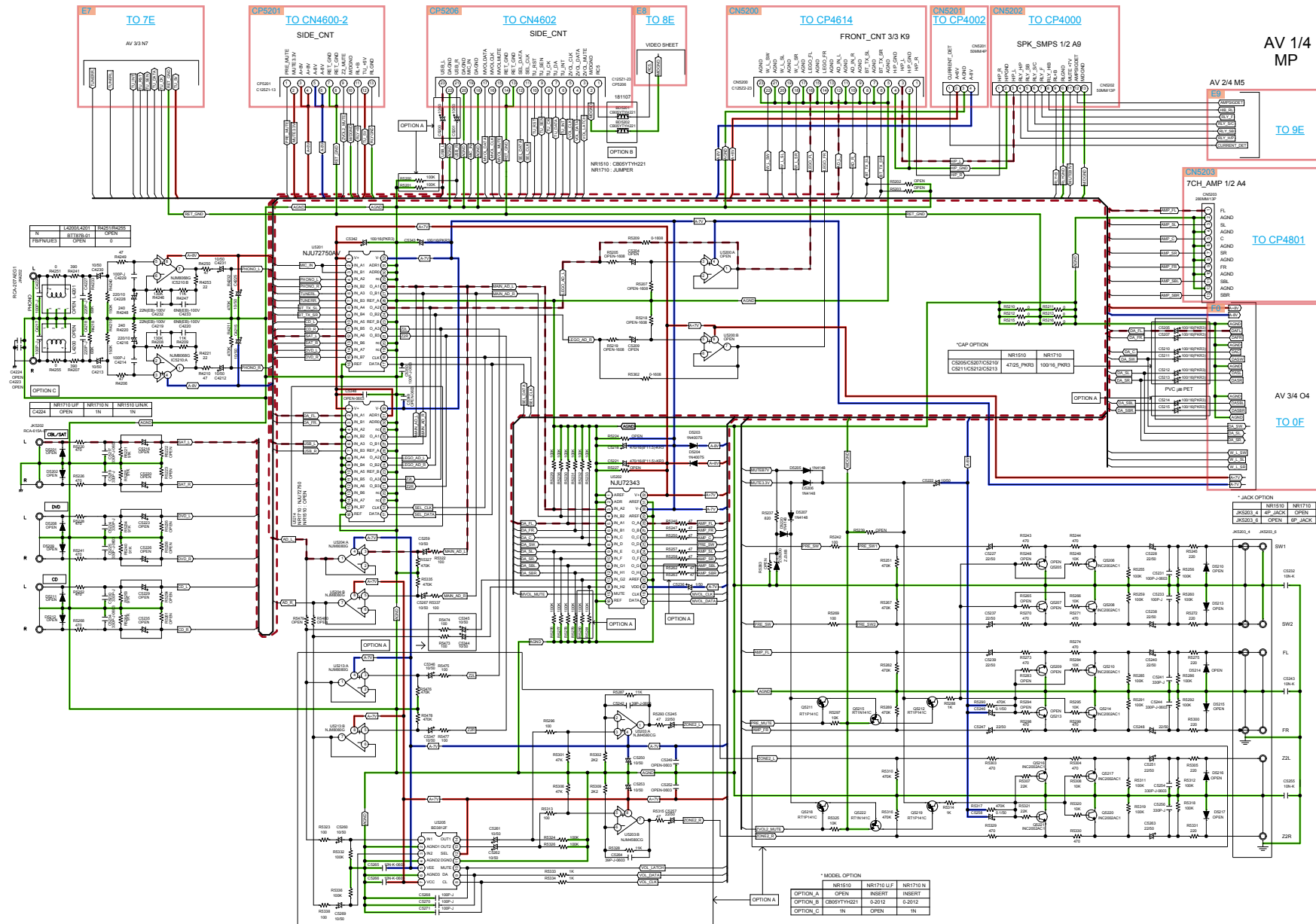

GND LINE    POWER+ LINE    POWER- LINE    ANALOG AUDIO    DIGITAL AUDIO    TMDS SIGNAL    VIDEO SIGNAL    COMPONENT(Y)    STBY POWER



AV 2/4  
MP

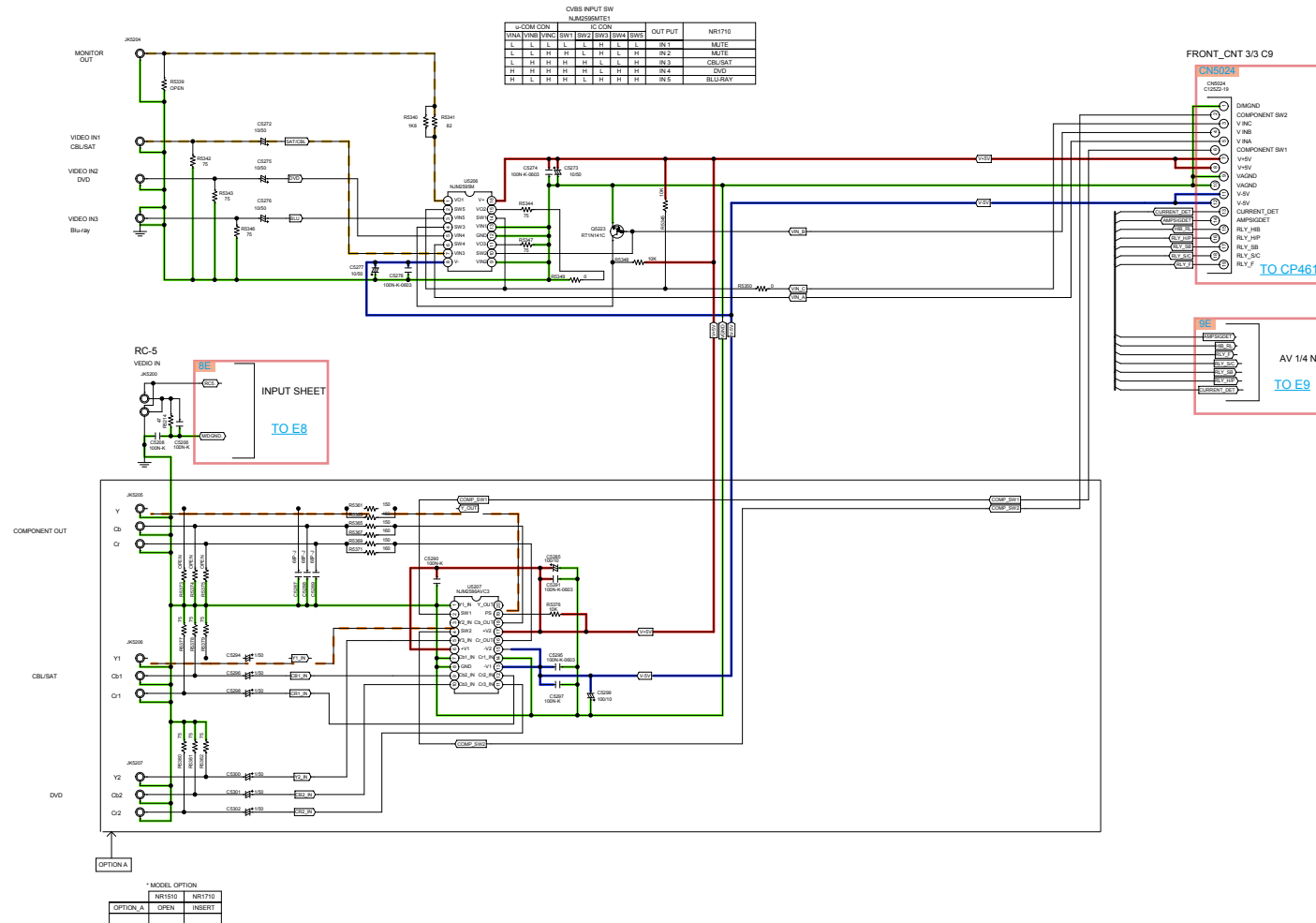

GND LINE    POWER+ LINE    POWER- LINE    ANALOG AUDIO    DIGITAL AUDIO    TMDS SIGNAL    VIDEO SIGNAL    COMPONENT(Y)    STBY POWER

## TUNER PACK

TUNER OPTION(WINEVER)	
MODEL	TUNER
LIBFB	YST90-AAU2 / F/MAH (F TYPE)
NR1B1SG	YST90-DBE3 / AMFHM-RDS (ECF PAL TYPE)
KOB	YST90-AJ21 / F/MAH (ECF PAL TYPE)

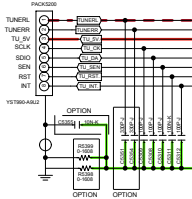

MODEL	R538	R539	C535	C536
NR170 L	□	□	□	□
NR170 N	OPEN	OPEN	TUN-K	TUN-K
NR1510 U / N / K	□	□	OPEN	OPEN

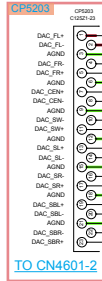

* DAC OPTION			
R543 / R544	NR170	NR1510	
R543 / R544	40K F	80K F	
R542 / R545	47K F	51K F	

* MODEL OPTION		
NR1510	NR170	
OPTION_A	OPEN	INSERT

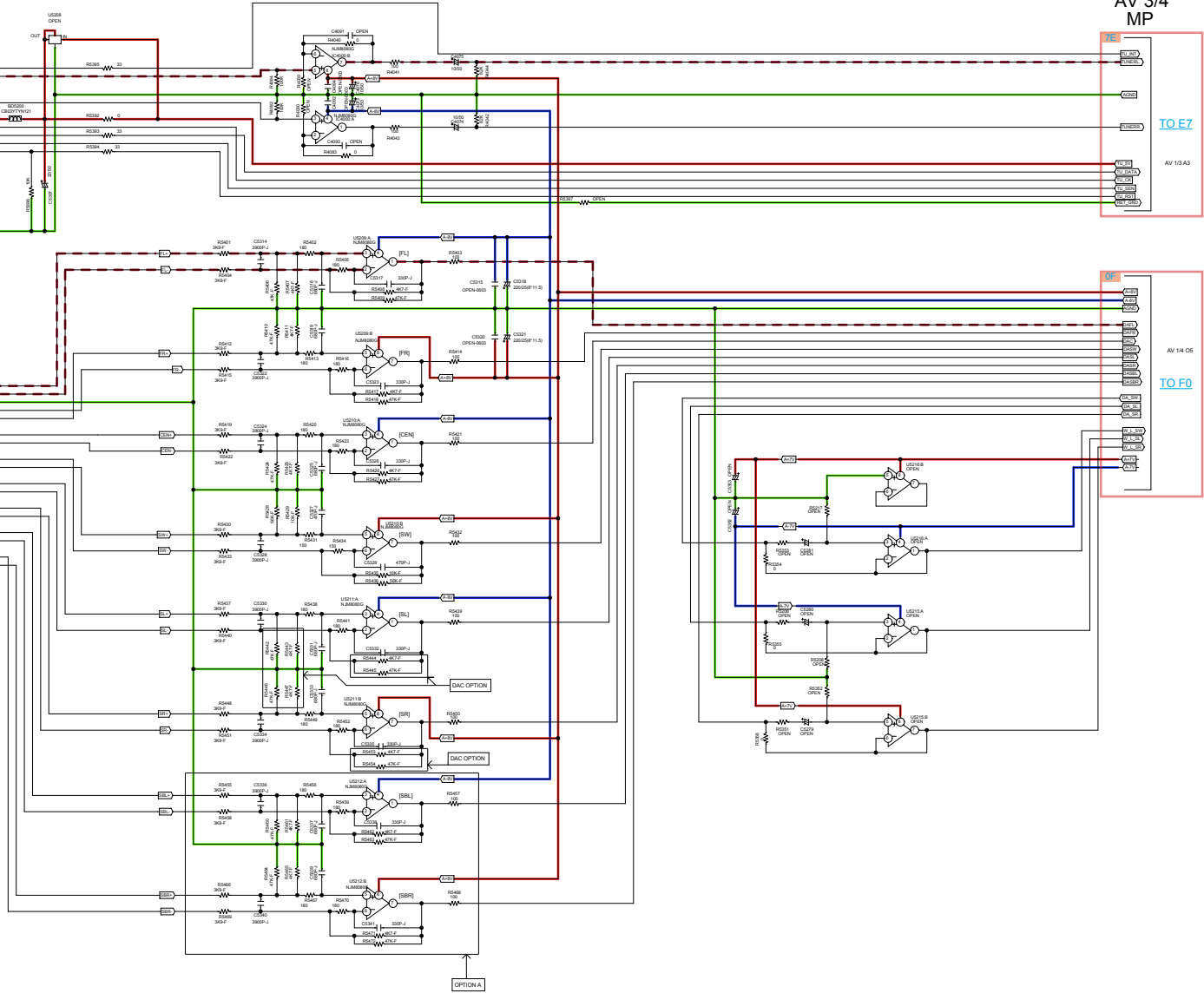

AV 3/4 MP

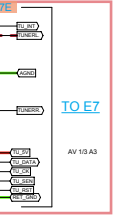

AV 1/4 CG

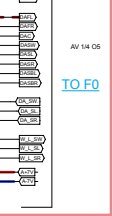

GND LINE    POWER+ LINE    POWER- LINE    ANALOG AUDIO    DIGITAL AUDIO    TMDS SIGNAL    VIDEO SIGNAL    COMPONENT(Y)    STBY POWER

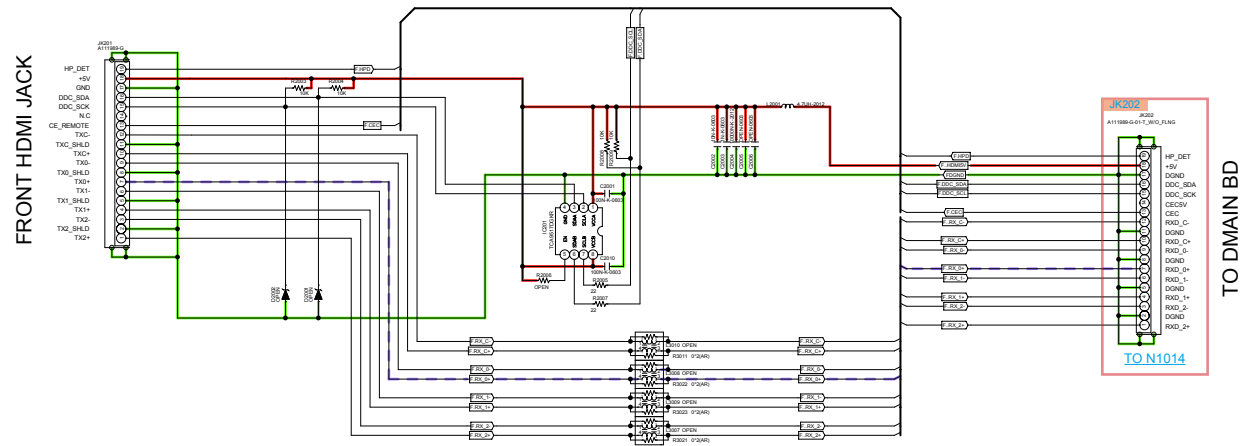

GND LINE    POWER+ LINE    POWER- LINE    ANALOG AUDIO    DIGITAL AUDIO    TMDS SIGNAL    VIDEO SIGNAL    COMPONENT(Y)    STBY POWER

NR1710 & NR1510 FRONT B'D

FRONT 1 / 1  
MP

⚠ INDICATES SAFETY CRITICAL COMPONENTS. TO REDUCE THE RISK OF ELECTRIC SHOCK, LEAKAGE CURRENT OR RESISTANCE MEASUREMENTS SHALL BE CARRIED OUT ( EXPOSED PARTS ARE ACCEPTABLY INSULATED FROM THE SUPPLY CIRCUIT ) BEFORE THE APPLIANCE RETURNED TO THE CUSTOMER.

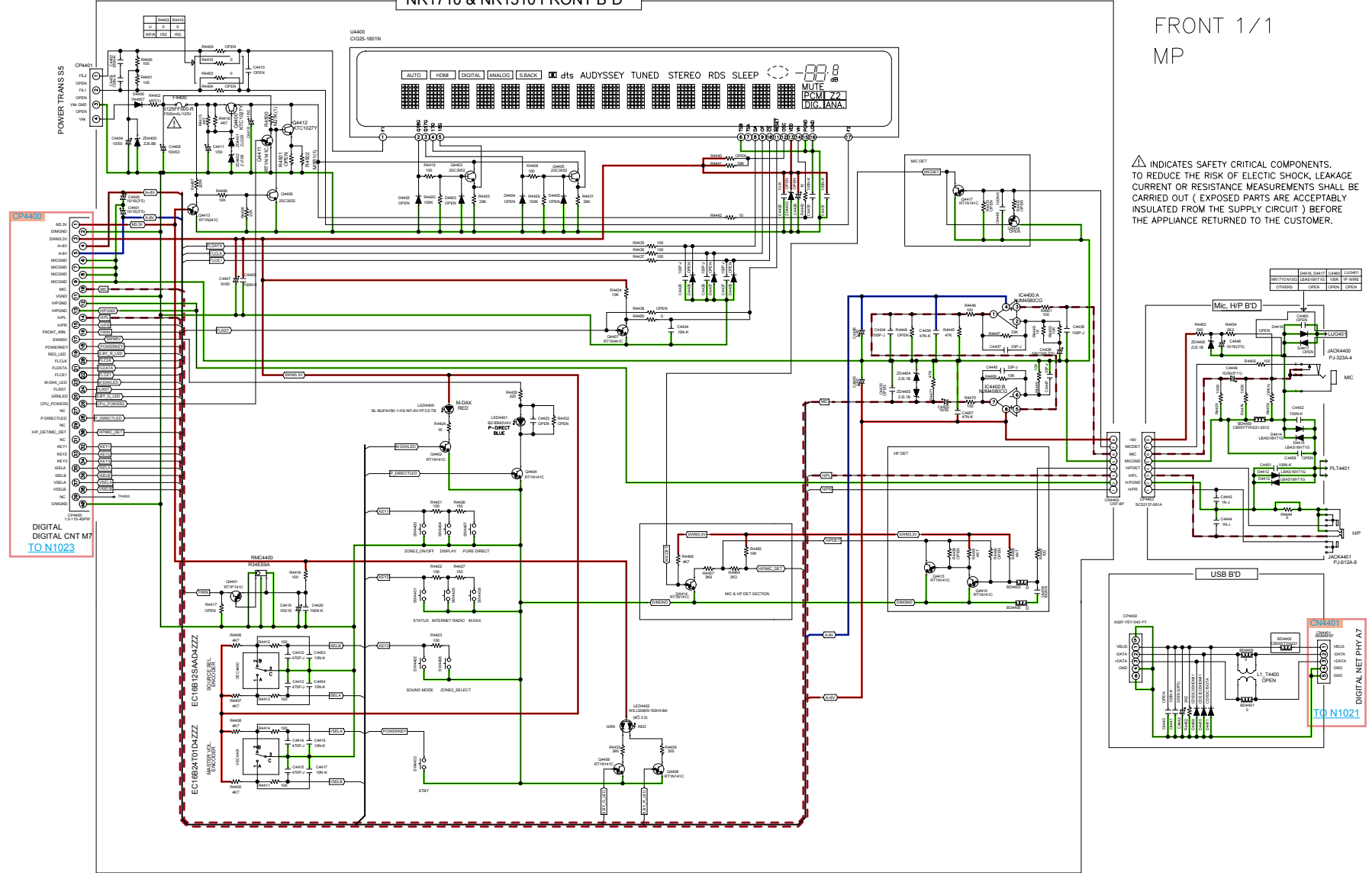

- GND LINE
- POWER+ LINE
- POWER- LINE
- ANALOG AUDIO
- DIGITAL AUDIO
- TMDS SIGNAL
- VIDEO SIGNAL
- COMPONENT(Y)
- STBY POWER

NR1710, NR1510 AMP B'D 1/2

AMP 1/2  
REF : 4800-5199  
MP

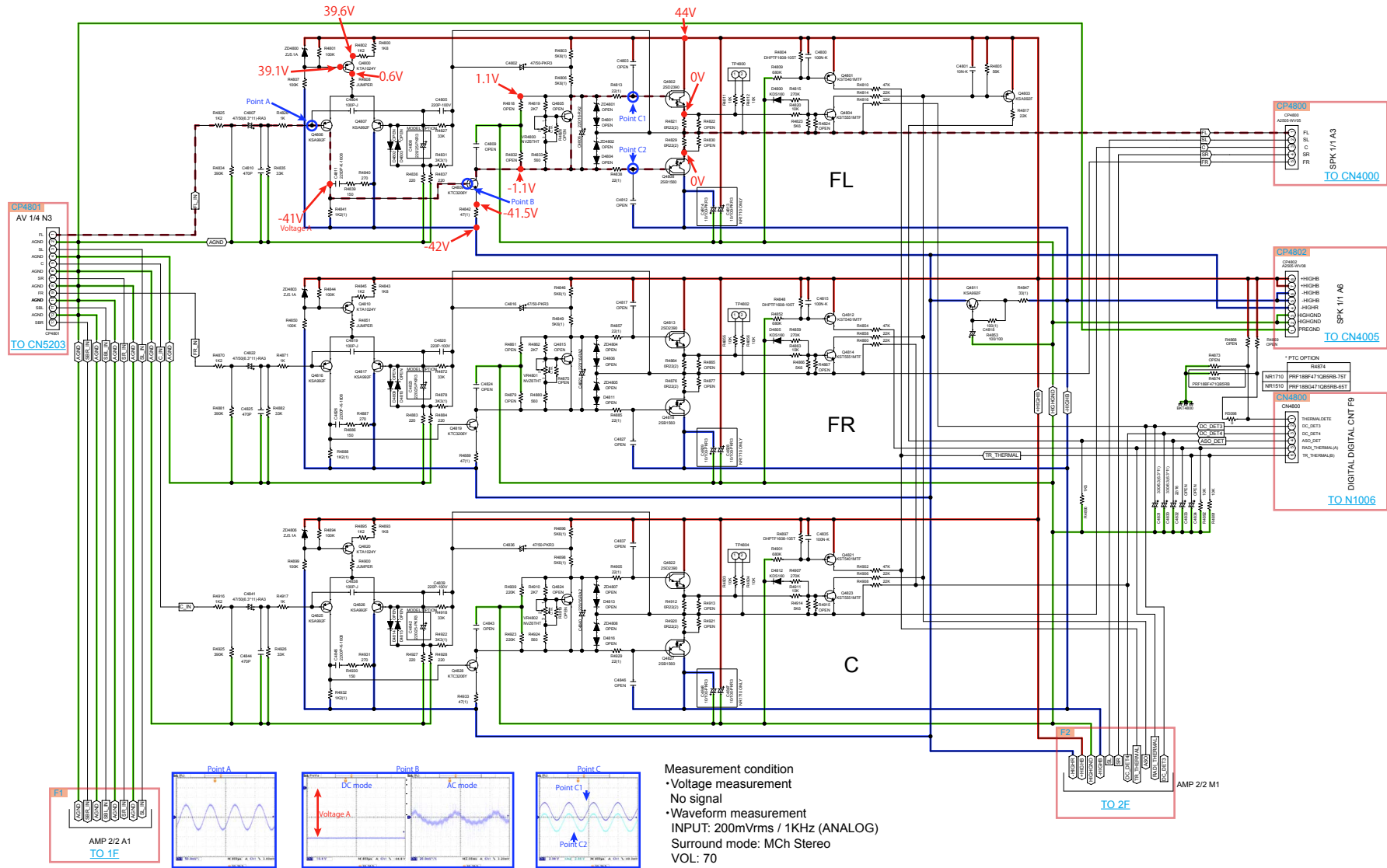

Measurement condition  
 • Voltage measurement  
 • No signal  
 • Waveform measurement  
 INPUT: 200mVrms / 1KHz (ANALOG)  
 Surround mode: MCh Stereo  
 VOL: 70  
 Speaker load: 8ohms

- 
 GND LINE
- 
 POWER+ LINE
- 
 POWER- LINE
- 
 ANALOG AUDIO
- 
 DIGITAL AUDIO
- 
 TMDS SIGNAL
- 
 VIDEO SIGNAL
- 
 COMPONENT(Y)
- 
 STBY POWER

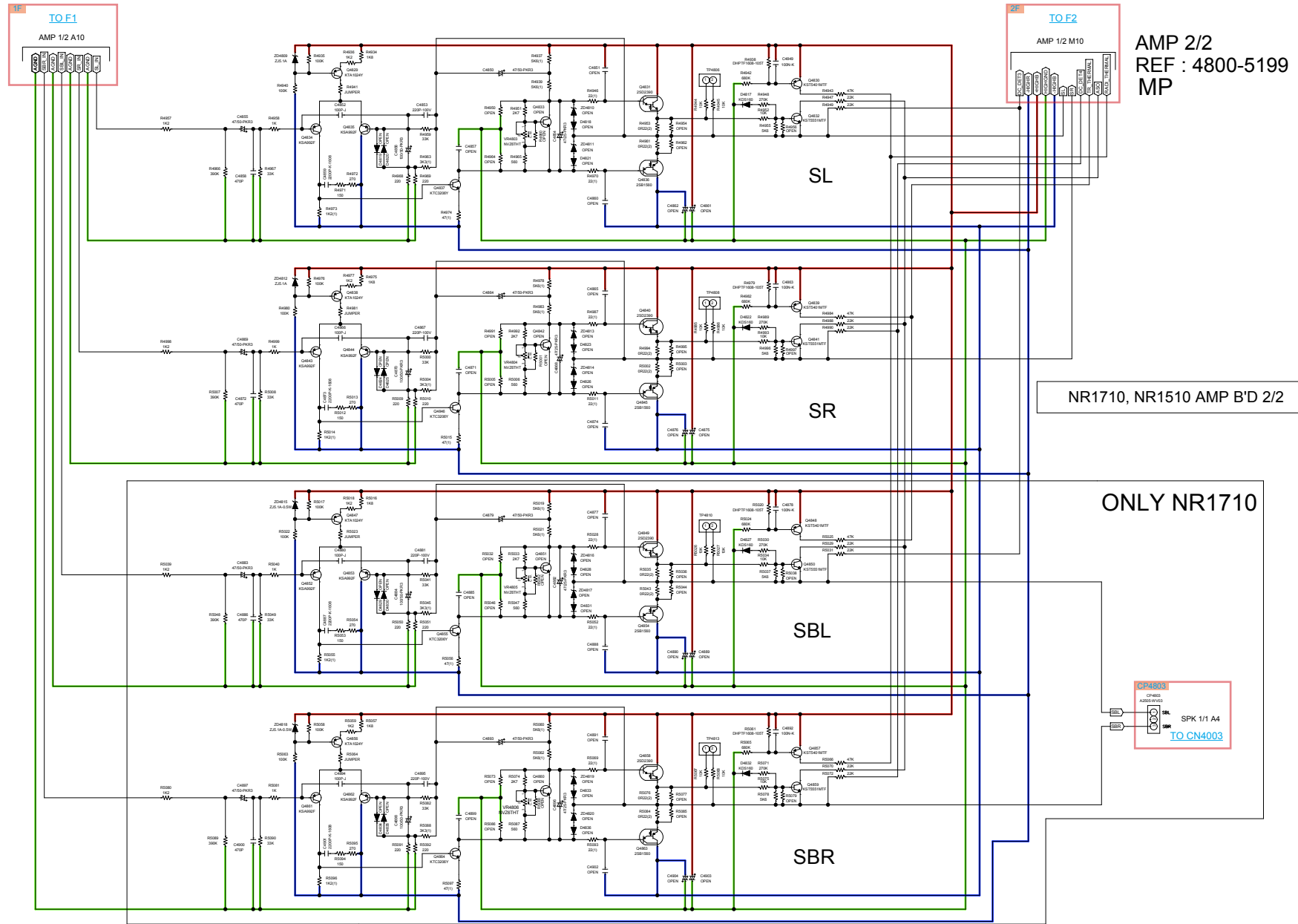

GND LINE    POWER+ LINE    POWER- LINE    ANALOG AUDIO    DIGITAL AUDIO    TMDS SIGNAL    VIDEO SIGNAL    COMPONENT(Y)    STBY POWER

SMPS\_REG\_FCNT 1/3 MP

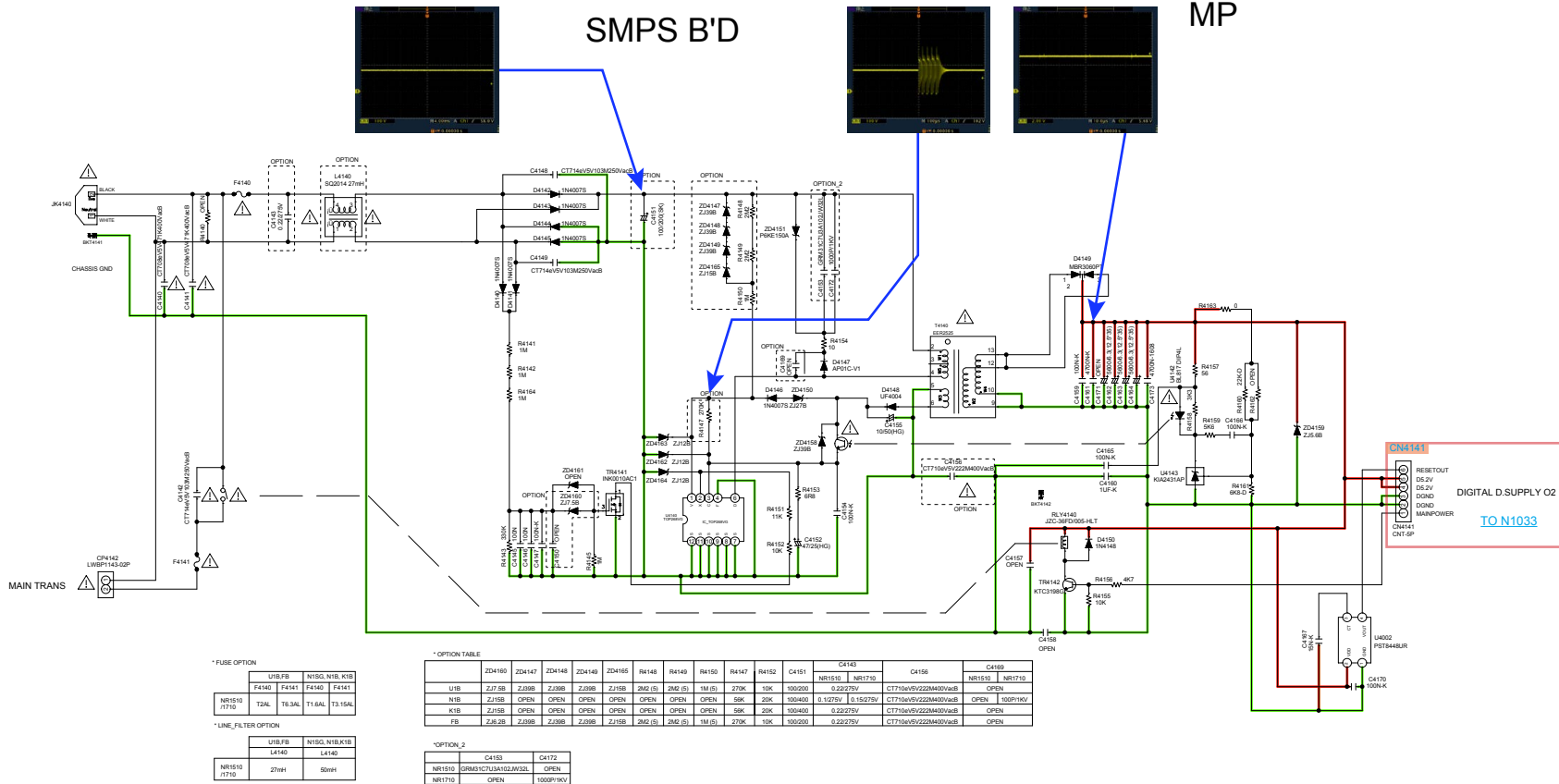

△ INDICATES SAFETY CRITICAL COMPONENTS. TO REDUCE THE RISK OF ELECTRIC SHOCK, LEAKAGE CURRENT OR RESISTANCE MEASUREMENTS SHALL BE CARRIED OUT ( EXPOSED PARTS ARE ACCEPTABLY INSULATED FROM THE SUPPLY CIRCUIT ) BEFORE THE APPLIANCE RETURNED TO THE CUSTOMER.

Before Servicing This Unit

Electrical

Mechanical

Repair Information

Updating

SMPS\_REG\_FCNT 2/3  
MP

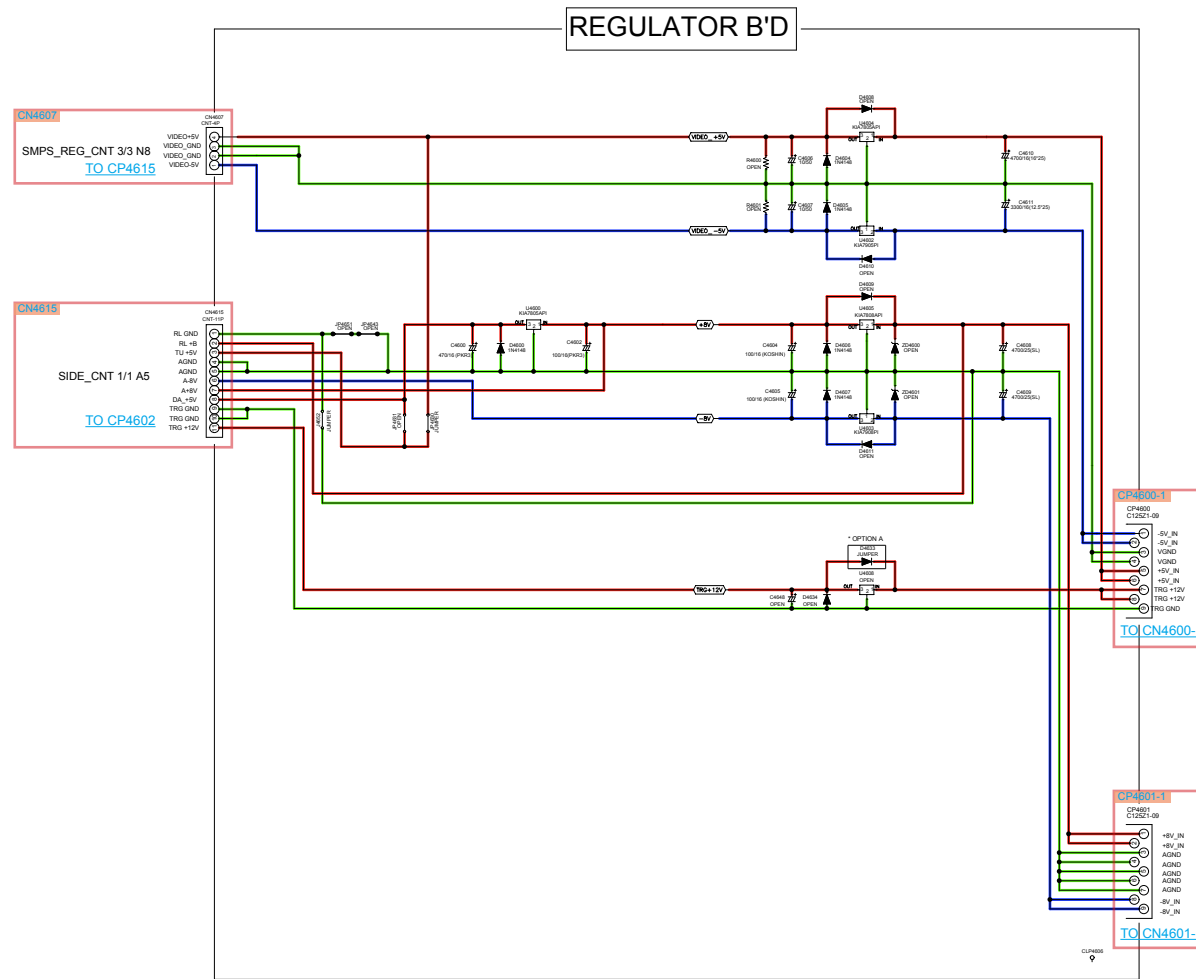

⚠ INDICATES SAFETY CRITICAL COMPONENTS.  
TO REDUCE THE RISK OF ELECTRIC SHOCK, LEAKAGE  
CURRENT OR RESISTANCE MEASUREMENTS SHALL BE  
CARRIED OUT ( EXPOSED PARTS ARE ACCEPTABLY  
INSULATED FROM THE SUPPLY CIRCUIT ) BEFORE  
THE APPLIANCE RETURNED TO THE CUSTOMER.

GND LINE    POWER+ LINE    POWER- LINE    ANALOG AUDIO    DIGITAL AUDIO    TMDS SIGNAL    VIDEO SIGNAL    COMPONENT(Y)    STBY POWER



FRONT CONNECTOR

SMPS\_REG\_FCNT 3/3  
MP

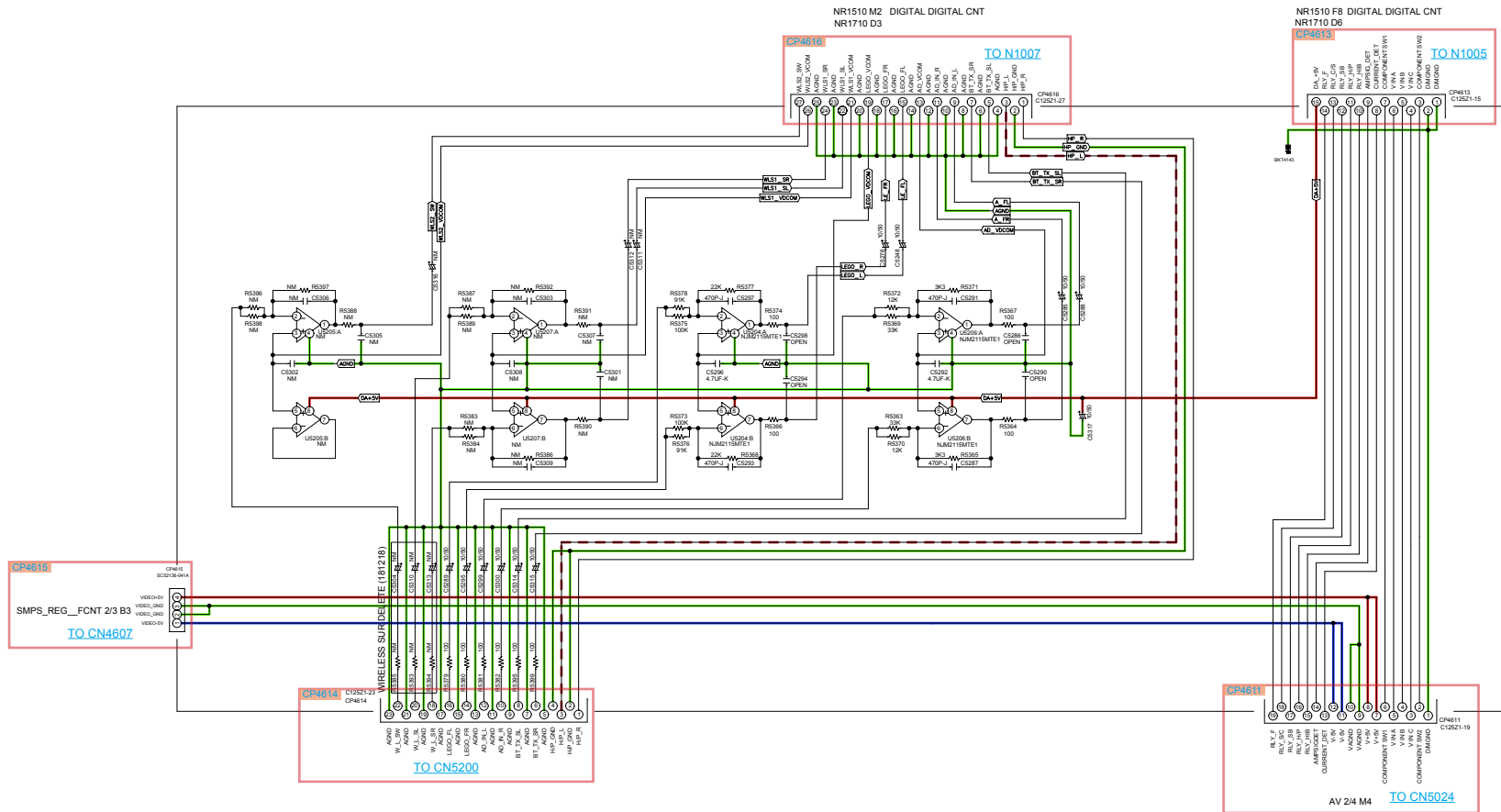

GND LINE    POWER+ LINE    POWER- LINE    ANALOG AUDIO    DIGITAL AUDIO    TMDS SIGNAL    VIDEO SIGNAL    COMPONENT(Y)    STBY POWER

# PRINTED CIRCUIT BOARDS

## DIGITAL, F HDMI

**Lead-free Solder**  
When soldering, use the Lead-free Solder (Sn-Ag-Cu).

DIGITAL (A SIDE)

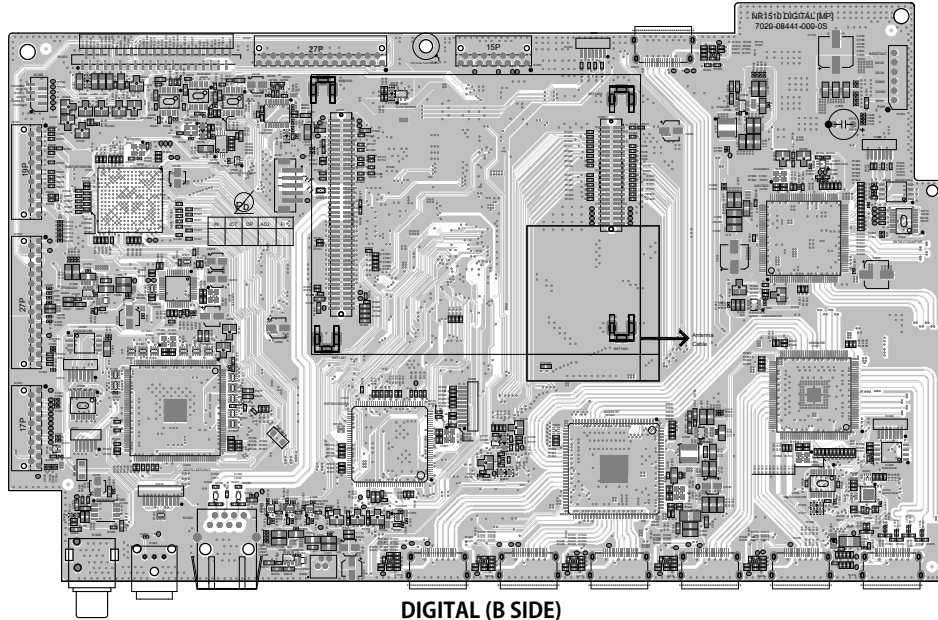

DIGITAL (B SIDE)

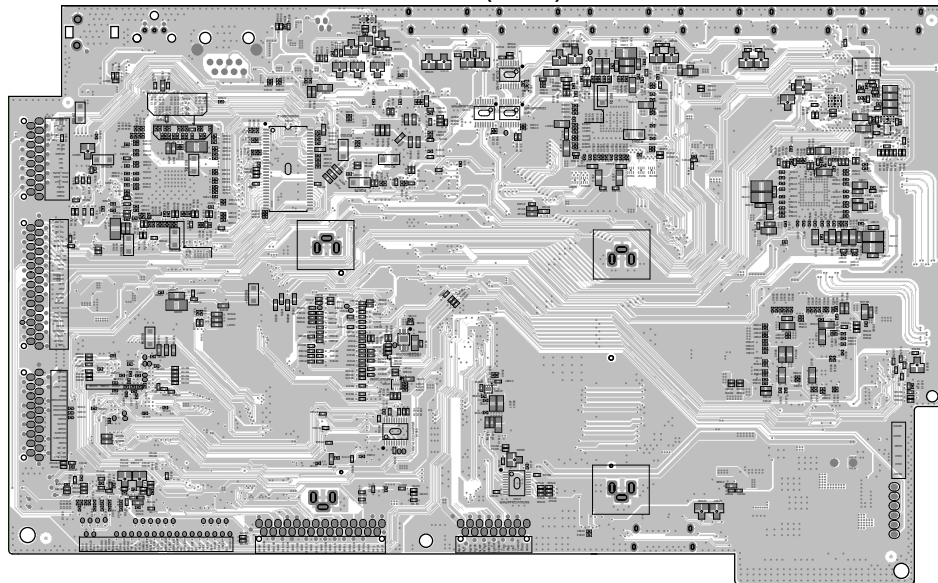

F HDMI (A SIDE)

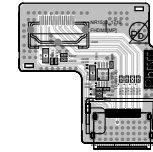

F HDMI (B SIDE)

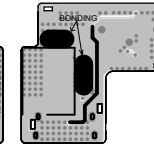

Before Servicing  
This Unit

Electrical

Mechanical

Repair Information

Updating

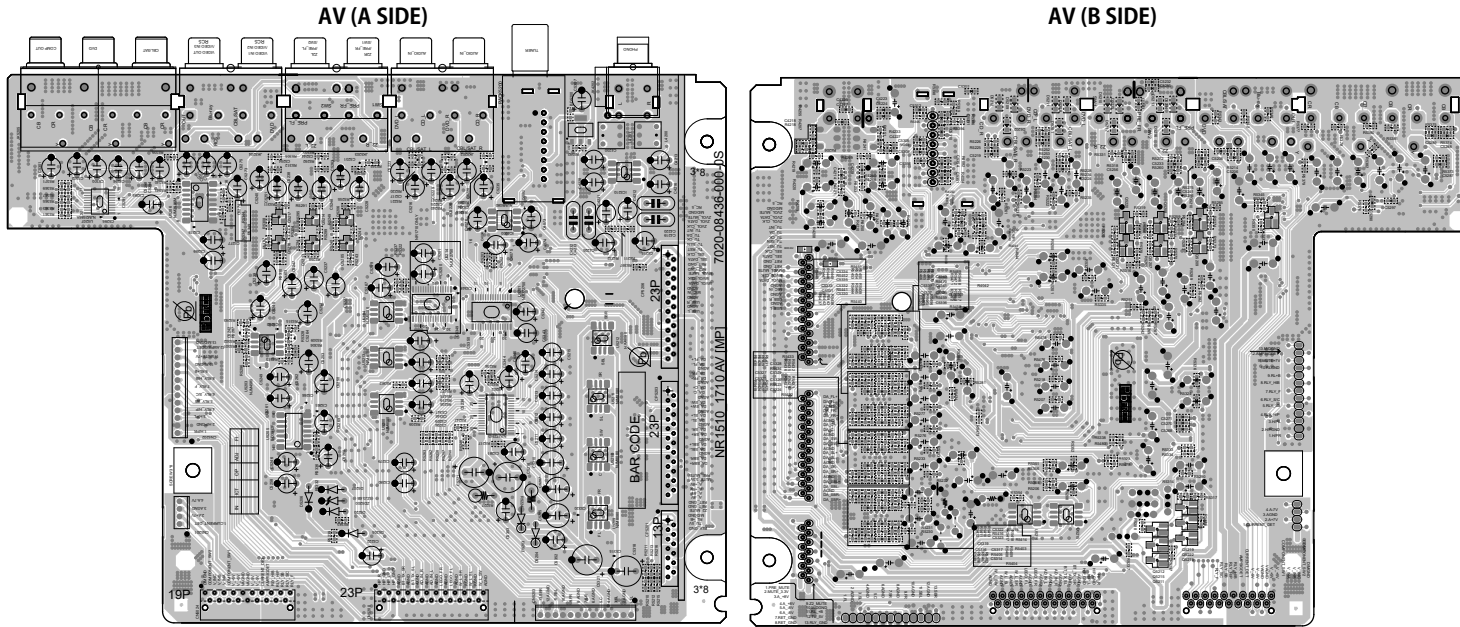

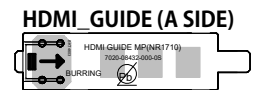
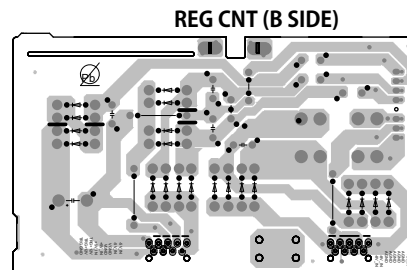
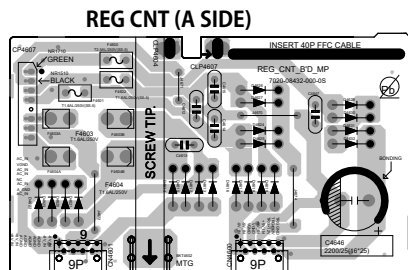
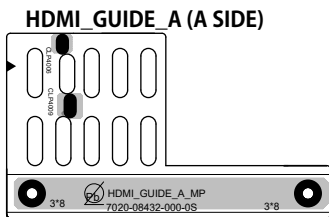
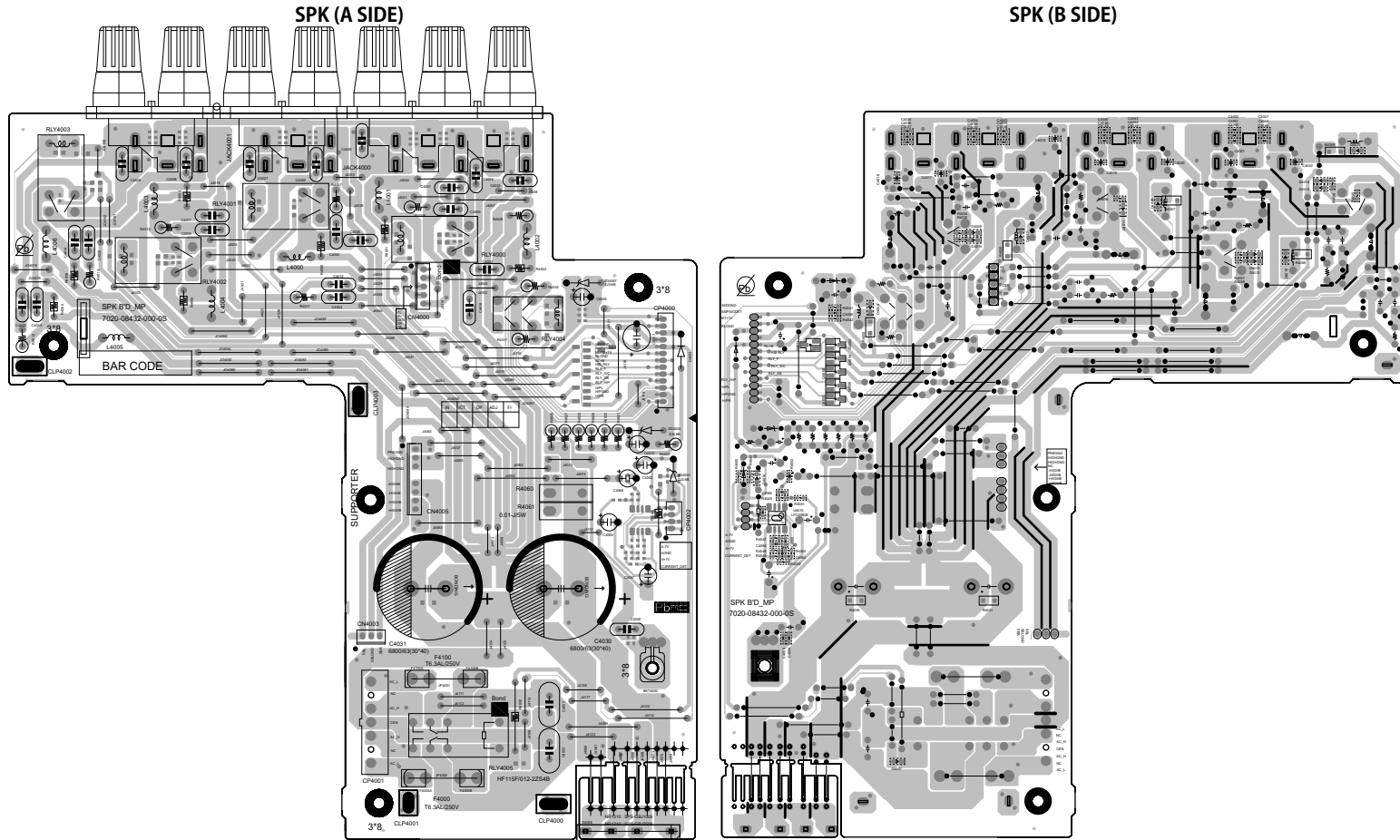

Before Servicing  
This Unit

Electrical

Mechanical

Repair Information

Updating

AMP (A SIDE)

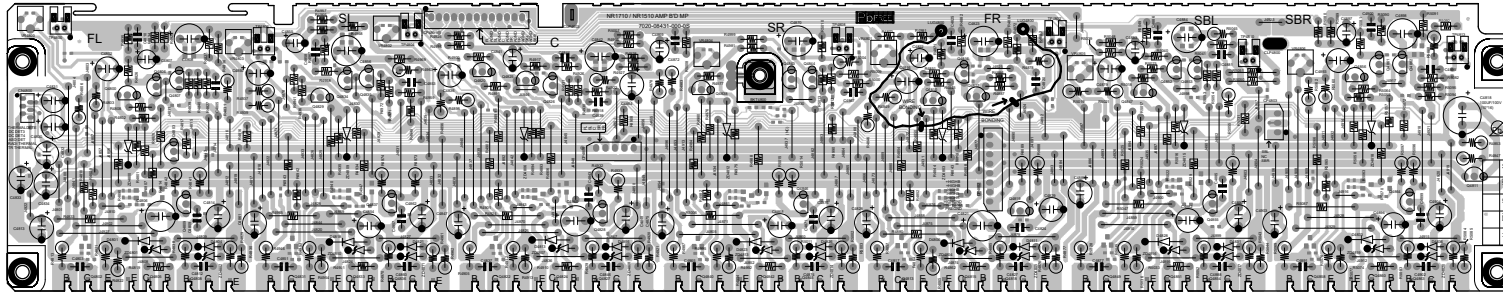

AMP (B SIDE)

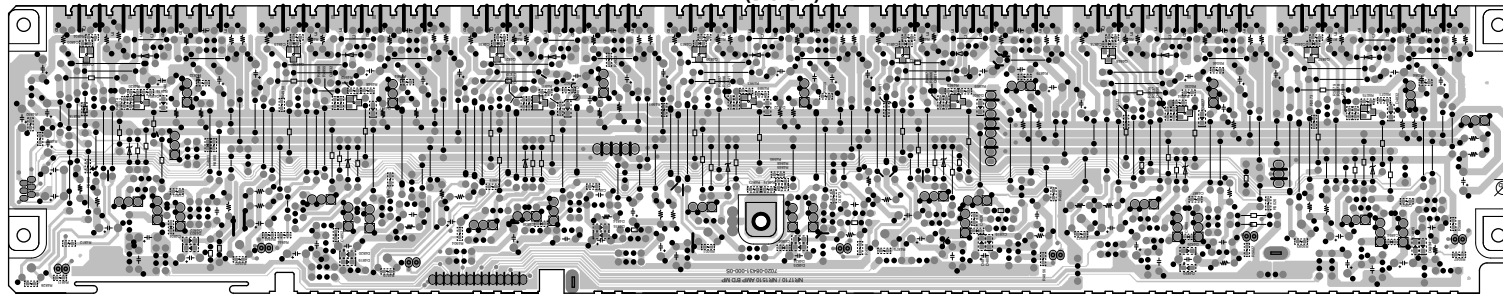

FRONT (A SIDE)

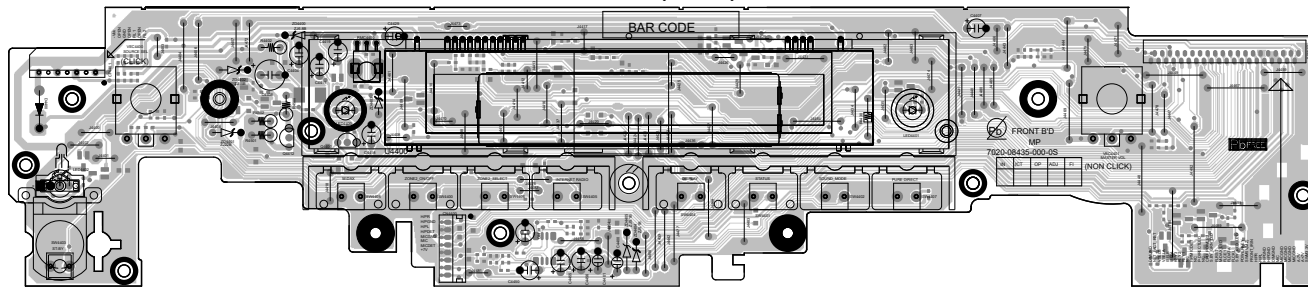

MC HP (A SIDE)

MC HP (B SIDE)

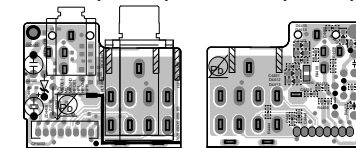

FRONT (B SIDE)

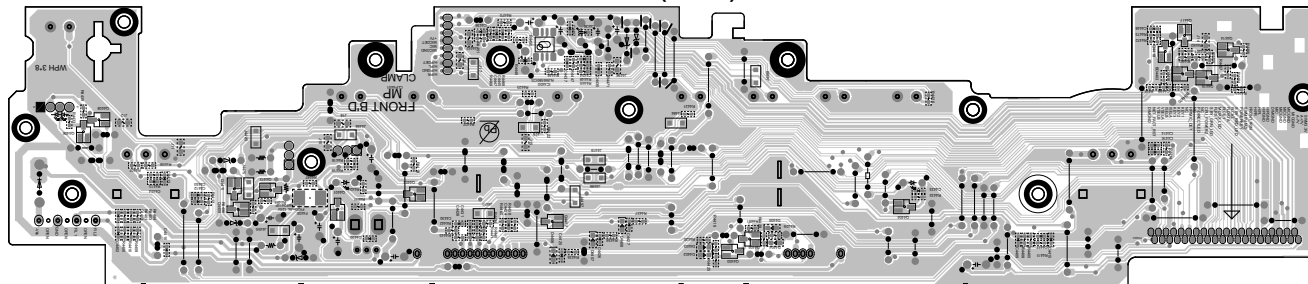

USB (A SIDE)

USB (B SIDE)

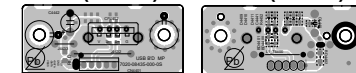

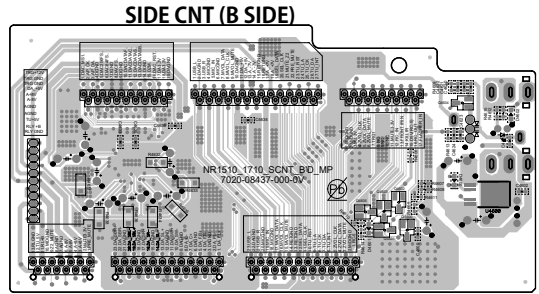
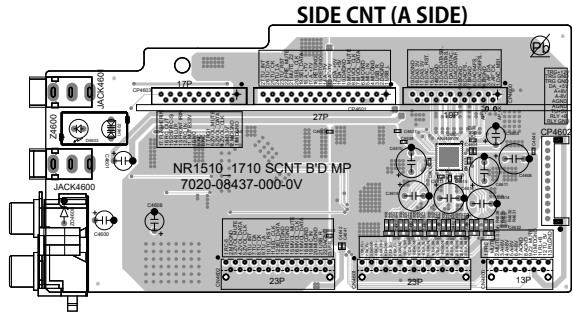
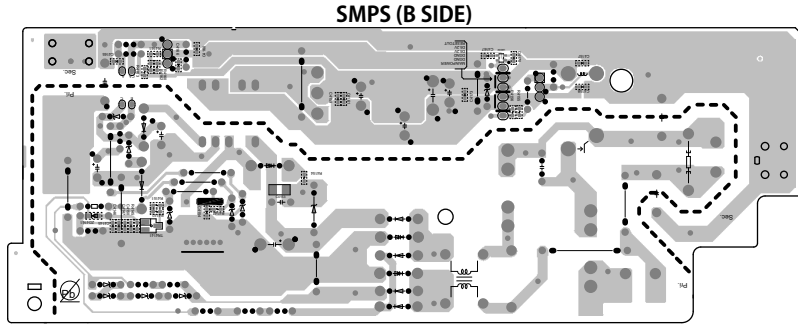
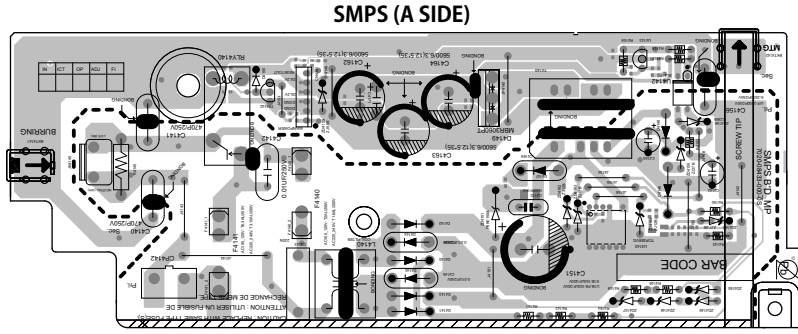
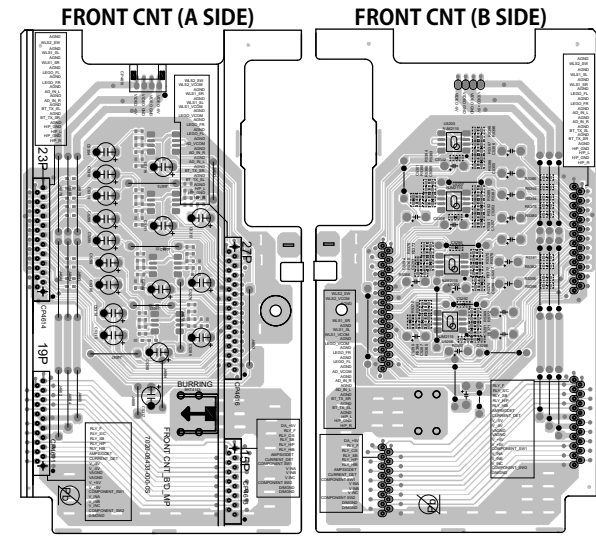
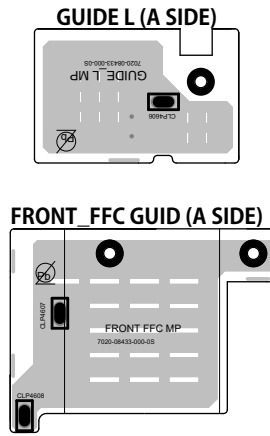
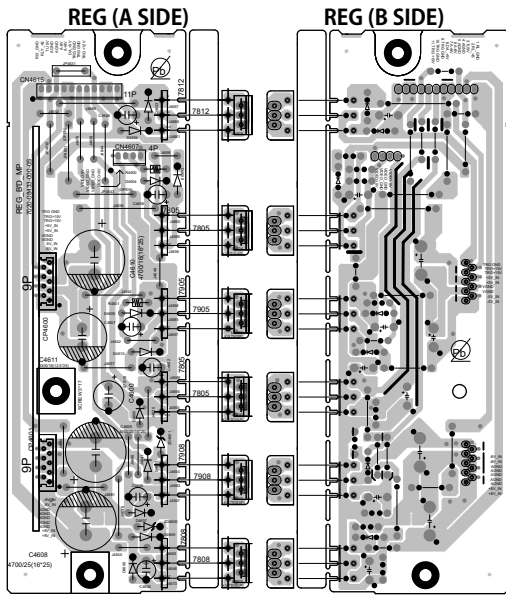

Before Servicing  
This Unit

Electrical

Mechanical

Repair Information

Updating

# LEVEL DIAGRAM

## FRONT ch

### NR1510 LEVEL DIAGRAM FRONT ch

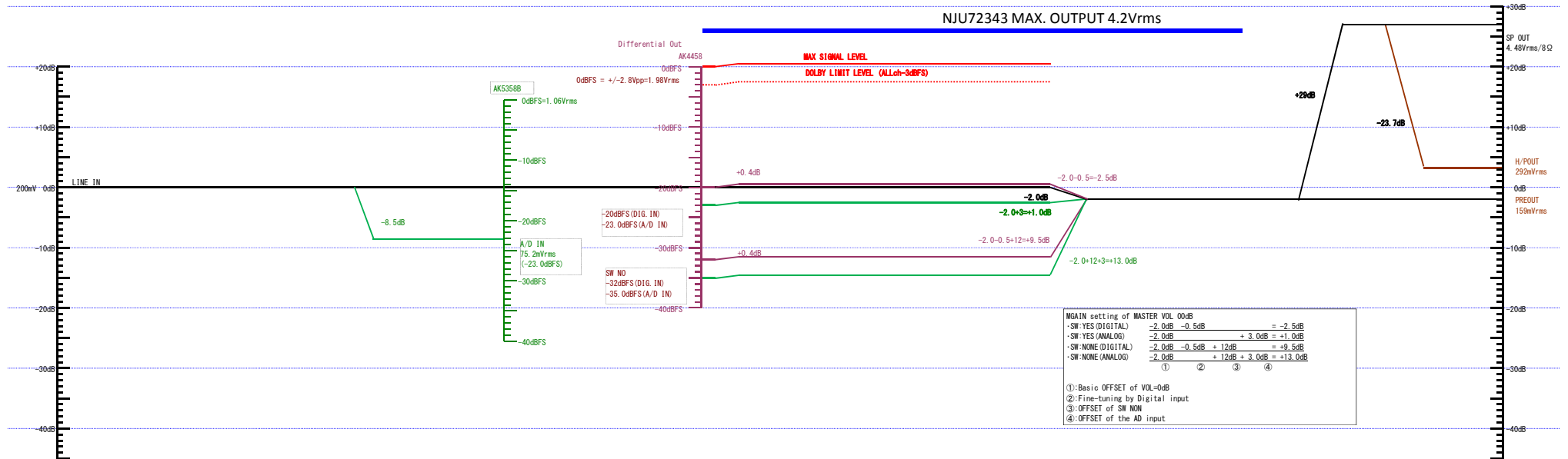
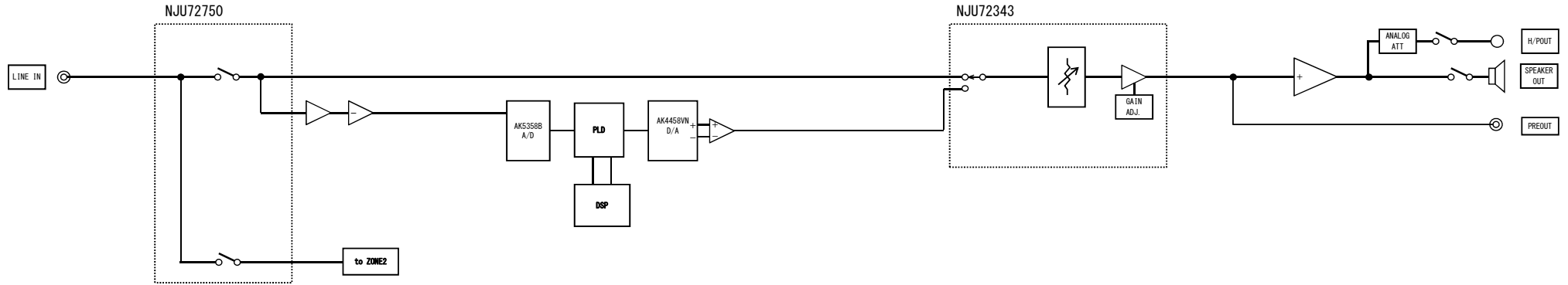

**NR1510**  
**LEVEL DIAGRAM**  
**CENTER ch**

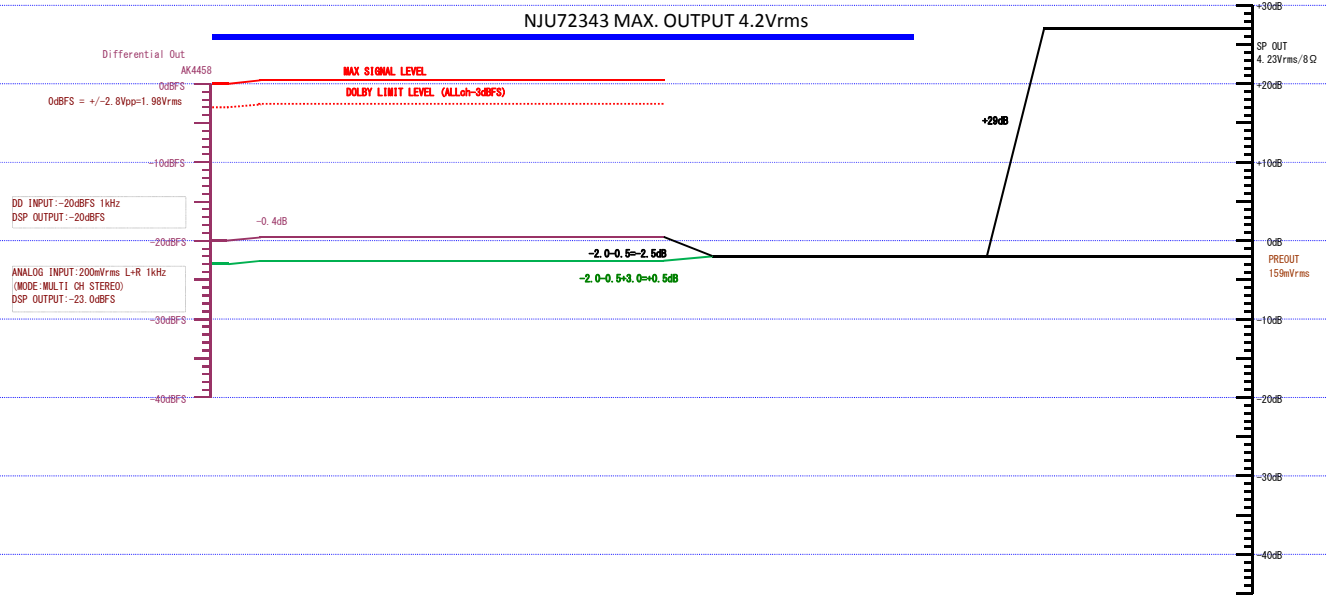
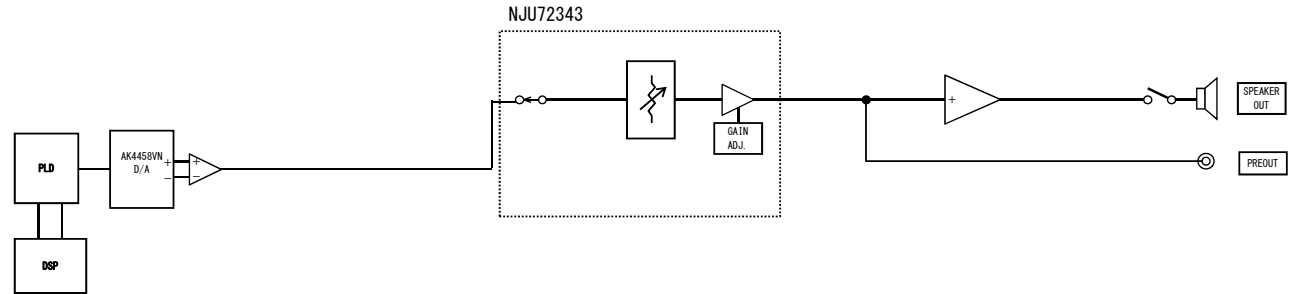



**NR1510  
LEVEL DIAGRAM  
SUBWOOFER ch**

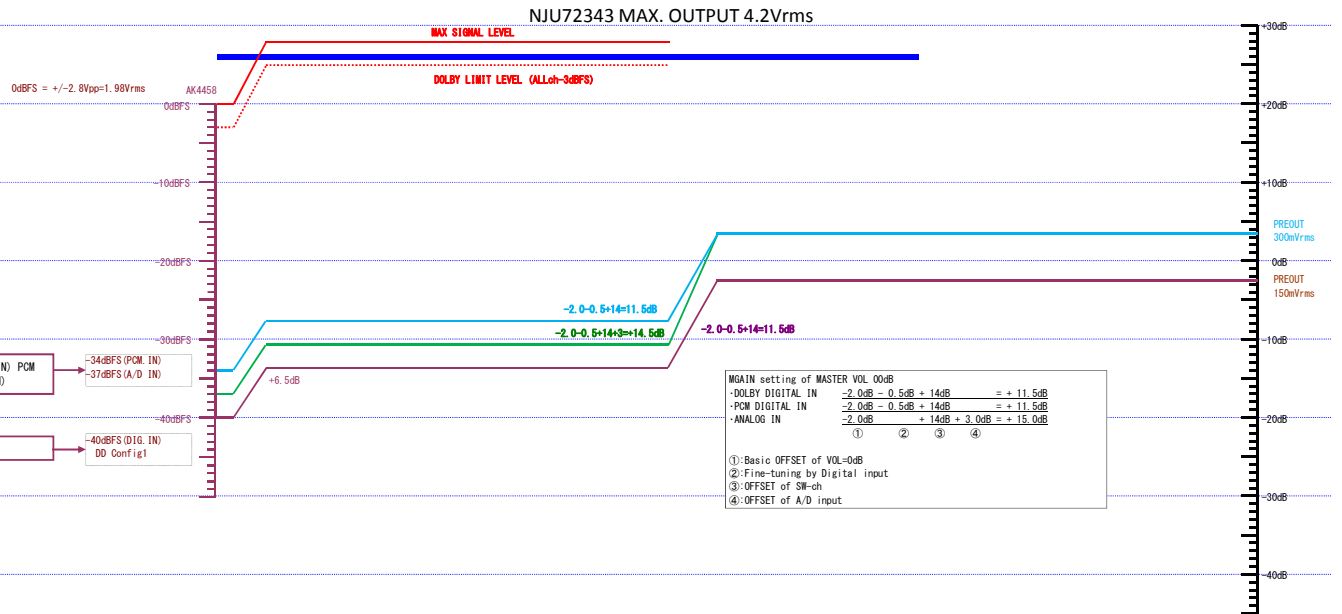
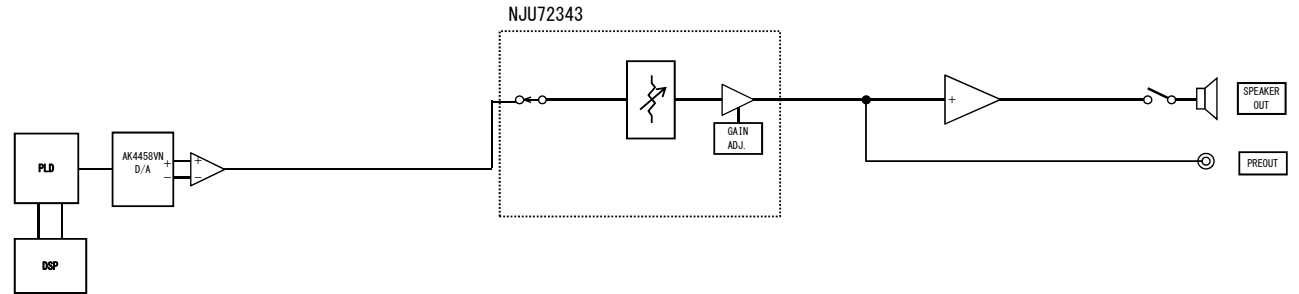

**NR1510  
LEVEL DIAGRAM  
SURROUND ch**

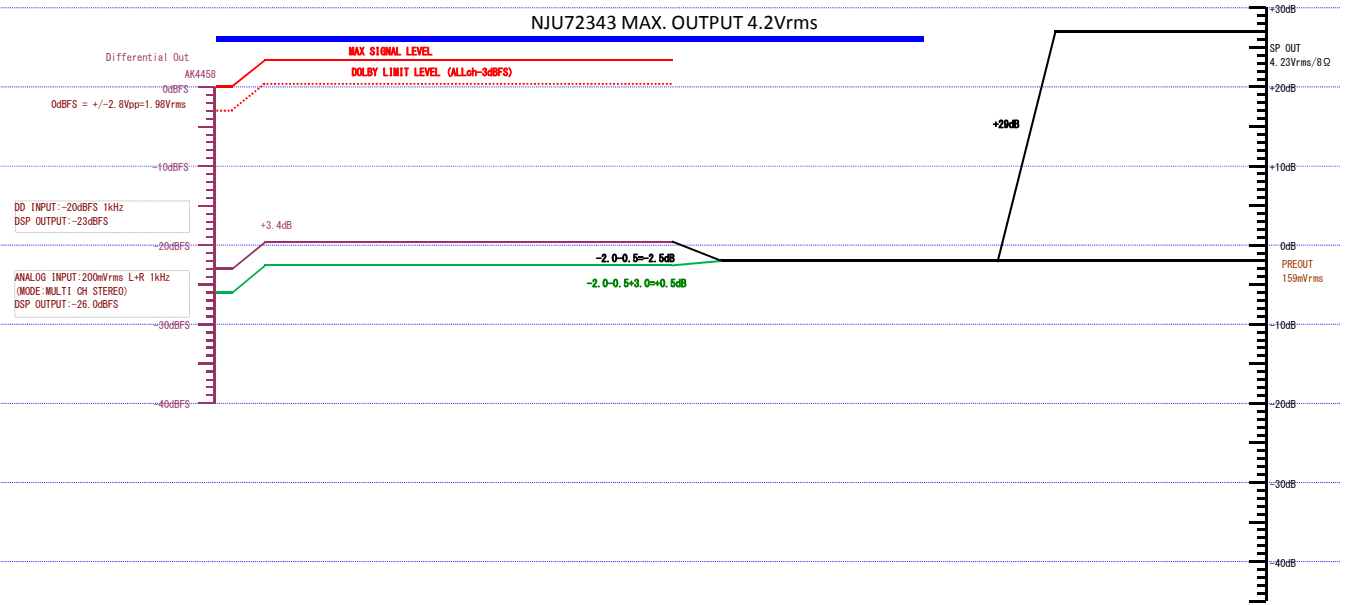
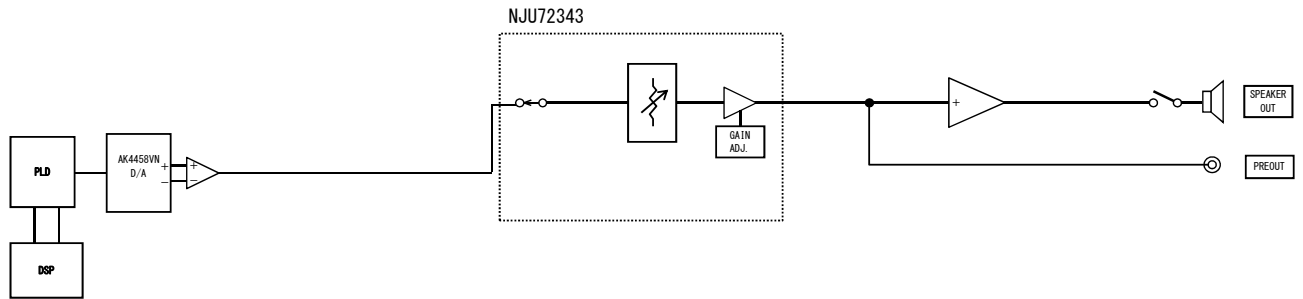

**NR1510  
LEVEL DIAGRAM  
LEGO ADC**

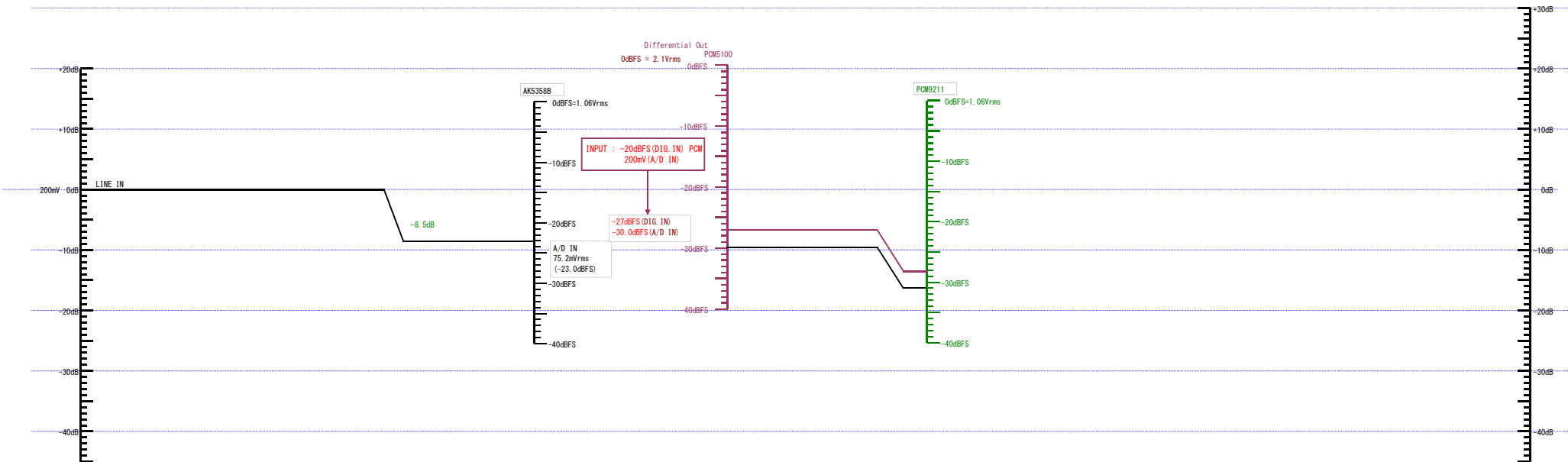
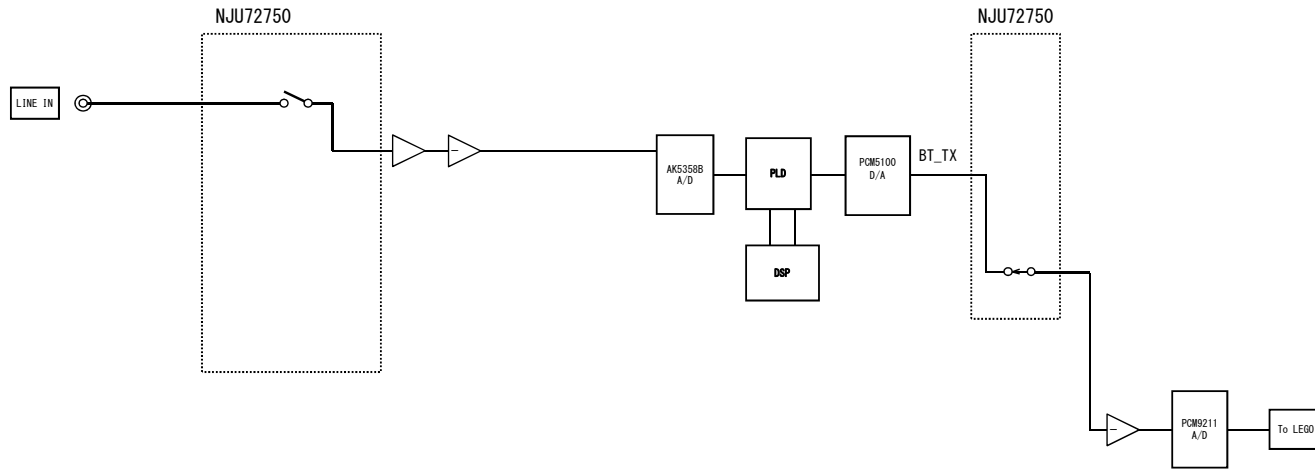

### NR1510 ANALOG AUDIO DIAGRAM

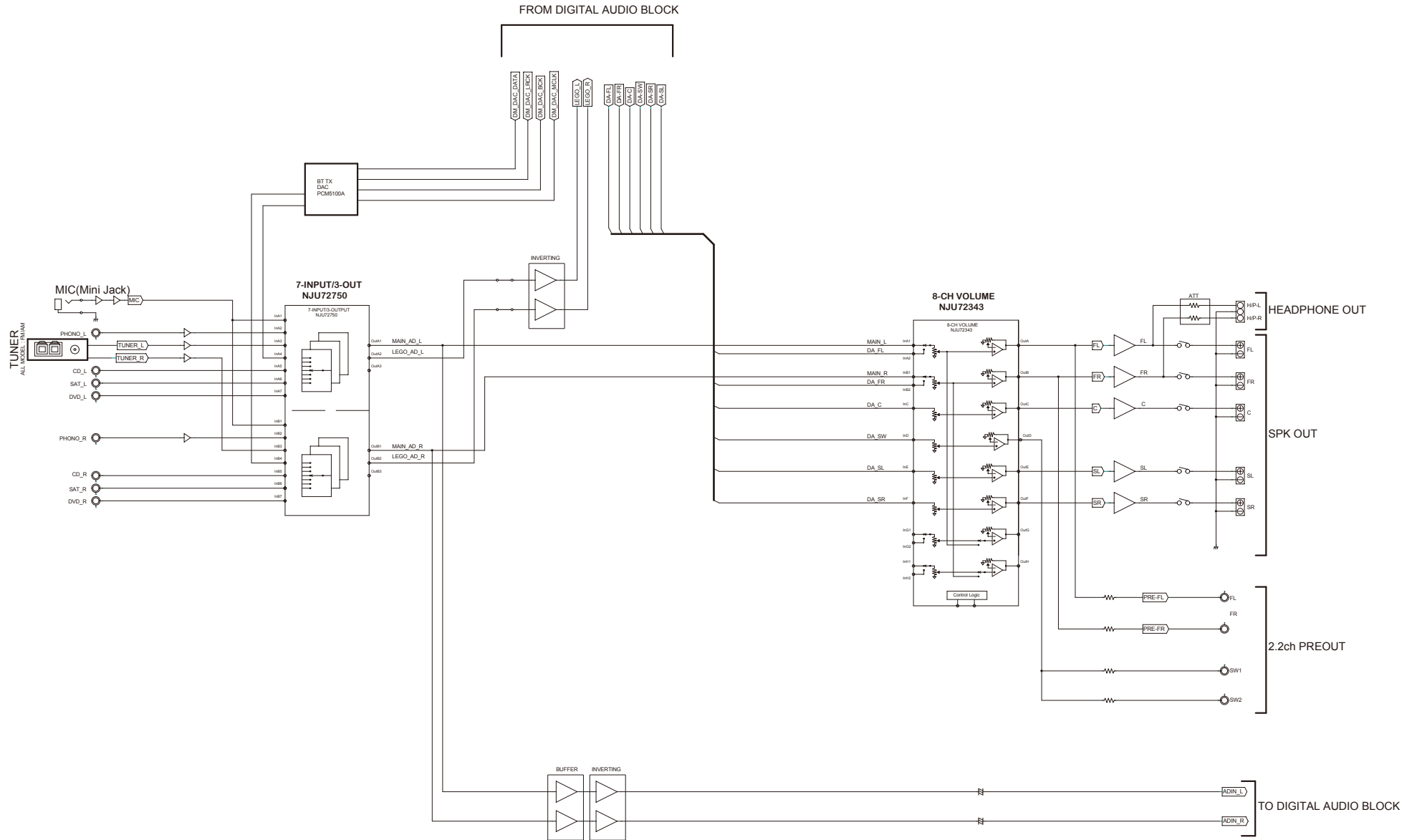

NR1510 DIGITAL AUDIO DIAGRAM

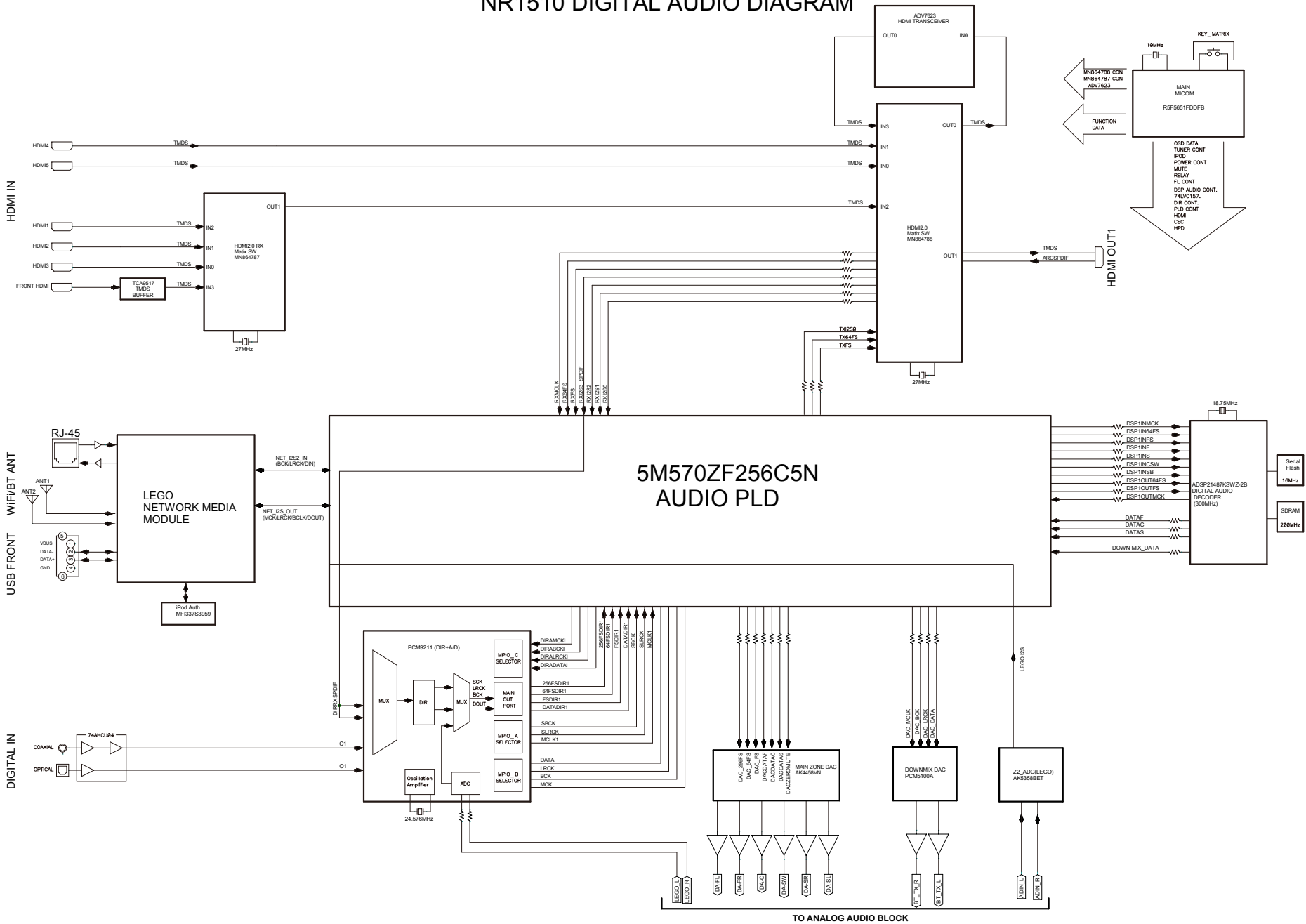

TO ANALOG AUDIO BLOCK

Before Servicing  
This Unit

Electrical

Mechanical

Repair Information

Updating

NR1510 VIDEO DIAGRAM

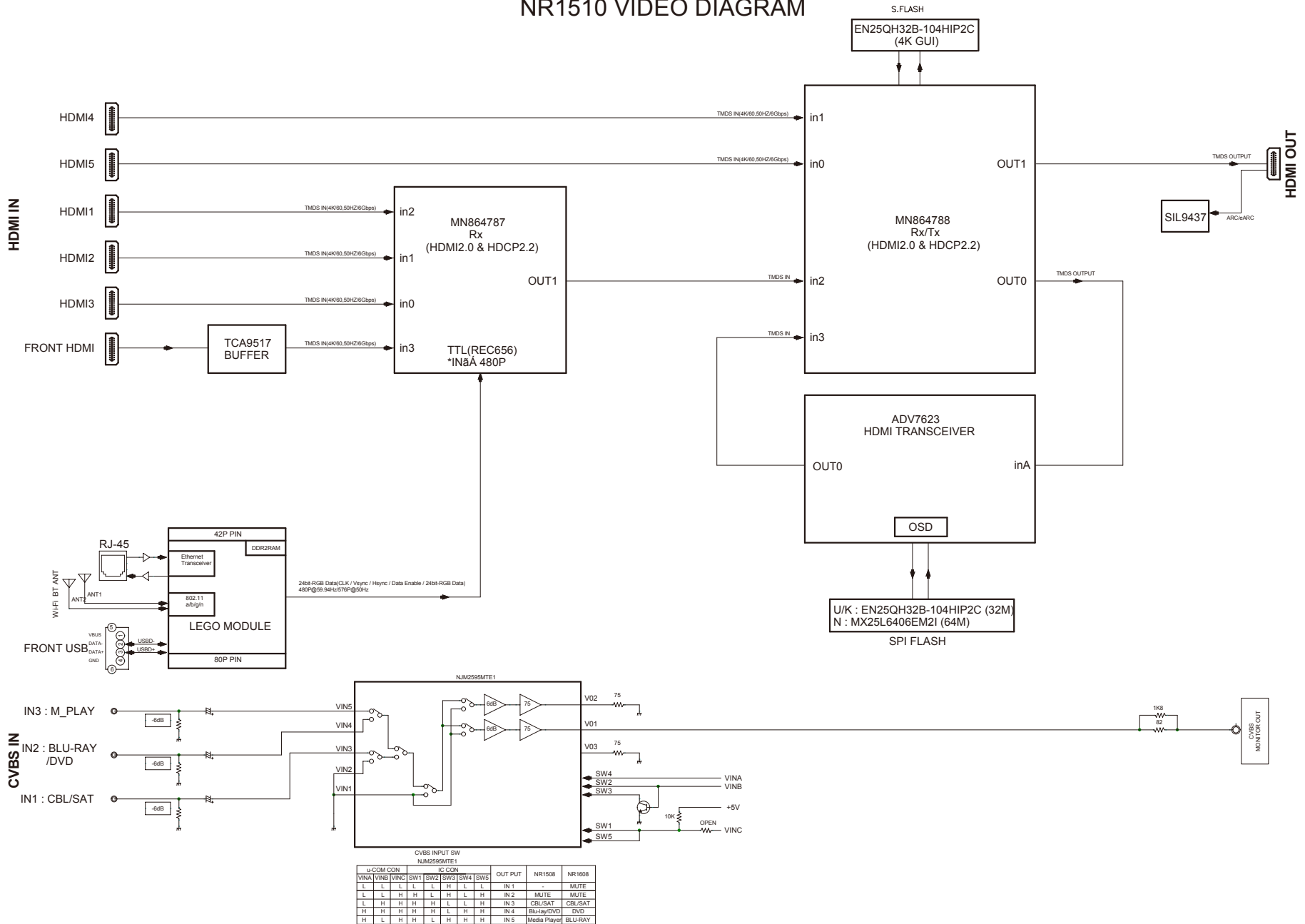

H-COM CON		IC CON					OUT PUT		NR1508	NR1608
VINA	VINB	VINC	SW1	SW2	SW3	SW4	SW5	IN 1	MUTE	
L	L	L	L	L	L	L	L	IN 1	MUTE	
L	L	R	H	L	H	L	H	IN 2	MUTE	
L	H	R	H	H	L	L	H	IN 3	CBL/SAT	
H	H	H	H	H	L	H	H	IN 4	Blu-ray/DVD	
H	L	H	H	L	H	H	H	IN 5	Media Player	
H	L	H	H	L	H	H	H	IN 5	BLU-RAY	

## NR1510 VCC DIAGRAM

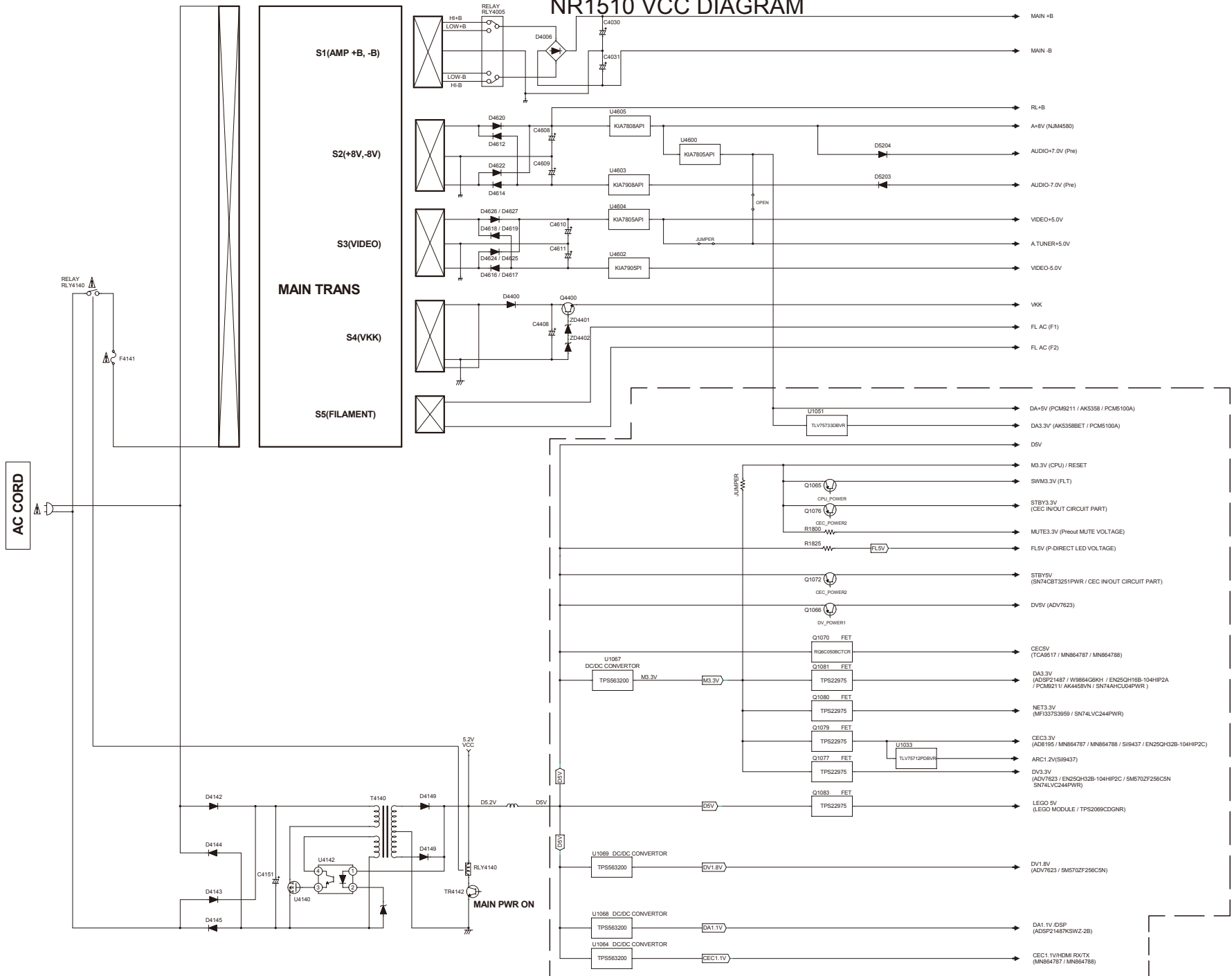

# WIRING DIAGRAM

## NR1510 WIRING BLOCK DIAGRAM

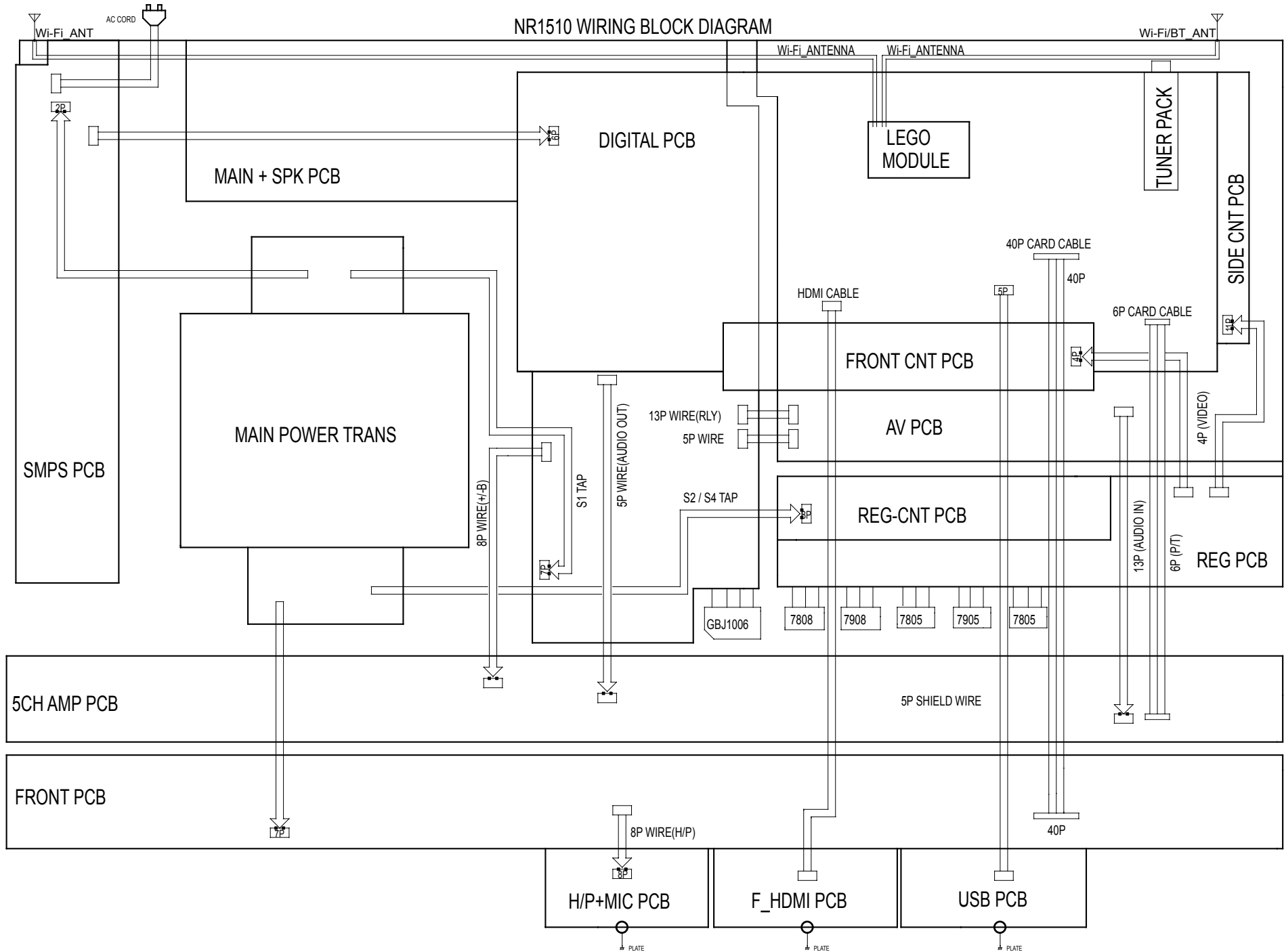

Before Servicing  
This Unit

Electrical

Mechanical

Repair Information

Updating



# SEMICONDUCTORS

Only major semiconductors are shown, general semiconductors etc. are omitted to list.  
The semiconductor which described a detailed drawing in a schematic diagram are omitted to list.

## 1. IC's

### R5F5631FDDFB(DIGITAL\_MCU : U1013)

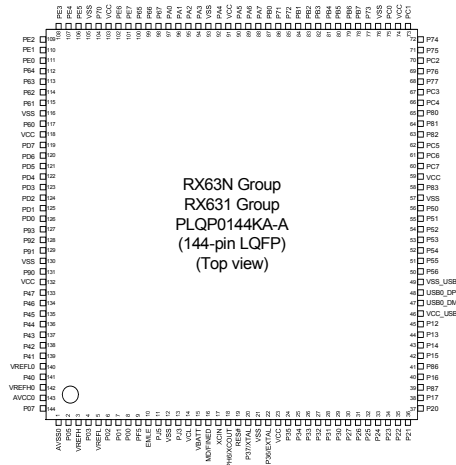

#### Terminal Functions

Pin	Pin Name	Symbol	I/O	Pu/Pd	STBY	STOP	CEC STBY	Function
1	AVSS0	AVSS	-	-	-	-	-	Ground pin
2	P05/IRQ13	POWER_KEY	I	M3VPu	I	I	I	Detect Power switch (Release from Wait Mode,Set to interrupt)
3	AVCC1	AVCC	-	-	-	-	-	Power supply pin
4	P03/IRQ11	RED_LED	O	-	L/H	L	H	POWER/STANDBY LED control pin
5	AVSS1	AVSS	-	-	-	-	-	Ground pin
6	P02/IRQ10/AN120	DIRECT_LED	O	-	L	L	L	DIRECT LED control pin
7	P01/RXD6/IRQ9/AN119	RXD_MI2320	I	Pd	I	I	I	External data input port (for AMX/FW update via 232C) :Connector is FFC
8	P00/TXD6/IRQ8/AN118	TXD_MO2321	O	-	L	L	L	External data output port (for AMX/FW update via 232C) :Connector is FFC
9	PF5/IRQ4	GREEN_LED	O	-	L	L	L	POWER LED control pin
10	EMLE	EMLE	I	Pd	-	-	-	E20 Emulator control pin (On chip Emulator is used,this pin should be High. Not used,it should be Low)
11	PJ5	VSEL_A	I	SW3VPu	I	I	I	Master volume (Rotary encoder) signal input pin
12	VSS	VSS	-	-	-	-	-	Ground pin
13	PJ3	VSEL_B	I	SW3VPu	I	I	I	Master volume (Rotary encoder) signal input pin
14	VCL	VCL	I	-	-	-	-	Smoothing capacitor connection pin
15	VBATT	VBATT	-	-	-	-	-	Power supply pin
16	MD/FINED	MD	I	M3VPu	I	I	I	Pins for setting the operating mode(select the Boot Mode or User Boot Mode,Single Chip Mode)
17	XCIN	XCIN	I	Pd	-	-	-	NC(Pull down)
18	XCOUT	XCOUT	I	-	-	-	-	NC(open)
19	RES#	RESET	I	M3VPu	-	-	-	Reset signal input pin
20	XTAL/P37	XTAL	I	-	-	-	-	Pins for a crystal resonator (Xin=12MHz × 10)
21	VSS	VSS	-	-	-	-	-	Ground pin
22	EXTAL/P36	EXTAL	-	-	-	-	-	Pins for a crystal resonator (Xin=12MHz × 10)
23	VCC	VCC	-	-	-	-	-	Power supply pin.

Pin	Pin Name	Symbol	I/O	Pu/Pd	STBY	STOP	CEC STBY	Function
24	UPSEL/P35(IN)/NMI	DSP_FLAG0	I	Pd	L	L	L	DSP(AD) interrupt signal input pin
25	TRST#/P34/SCK6/SCK0/IRQ4	TRST#/NC(NORMAL)	I/I	Pd	I/I	I/I	I/I	E20 Emulator control pin/When normal operating mode,set to input.
26	P33/TIOCD0/RXD6/RXD0/IRQ3-DS	RC_IN	I	M3VPu	I	I	I	Remote input
27	P32/TXD6/TXD0/IRQ2-DS	BDOWN	I	M3VPu	I	I	I	Detect power down
28	TMS/P31/IRQ1-DS	TMS/NC(NORMAL)	I/I	M3VPu	-/I	-/I	I	E20 Emulator control pin/When normal operating mode,set to input.
29	TDI/P30/RXD1/IRQ0-DS	TDI/RXD_MIT-SUBISHI	I/O/I	M3VPu	-/I	-/I	I	E20 Emulator control pin/Mitsubishi writer control pin/When normal operating mode,set to input.
30	TCK/FINEC/P27/SCK1/	TCK/NC(NORMAL)	I/I/I	M3VPu	-/I	-/I	I	E20 Emulator control pin/When normal operating mode,set to input.
31	TDO/P26/TXD1	TDO/TXD_MITSUBISHI	O/O/I	M3VPu	-/I	-/I	I	E20 Emulator control pin/Mitsubishi writer control pin/When normal operating mode,set to input.
32	P25/RXD3	ADV7623_RST	O	Pd	L	L	L	HDMI transceiver w/ GUI(ADV7623) reset control pin
33	P24/SCK3	MVOL_MUTE	O	-	L	L	L	Volume control pin (NJU72343)
34	P23/TXD3	E_RTS_MOEI	O	Pd (onboard+BCMS8305 Internal Pd)	L	L	L	Ethernet(Network Module) control pin
35	P22/SCK0	E_CTS_MIEO	I	Pd (onboard+BCMS8305 Internal Pd)	I	I	I	Ethernet(Network Module) control pin
36	P21/RXD0/IRQ9	E_RXD_MIEO	I	Pd (onboard+BCMS8305 Internal Pd)	I	L	I	Ethernet(Network Module) control pin
37	P20/TXD0/IRQ8	E_TXD_MOEI	O	Pd (onboard+BCMS8305 Internal Pd)	L	L	L	Ethernet(Network Module) control pin
38	P17/SCK1/TXD3/IRQ7	NET_FACT_RST	O(ODR)	Pu (BCMS8305 Internal Pu)	Z	Z	Z	Ethernet(Network Module) control pin
39	P87	7623_ROM_HOLD	O	Pu	L	L	L	Flash ROM for GUI control pin
40	P16/TXD1/RXD3/IRQ6	TU_CK	O	SW3VPu	L	L	L	TUNER control
41	P86	NC	O	-	L	L	L	NC
42	P15/RXD1/IRQ5	TU_DA	I_O	SW3VPu	L	L	L	TUNER control
43	P14/IRQ4	VEXP_OE	O	-	L	L	L	Expander (MC14094) control pin
44	P13/TXD2/IRQ3	VEXP_CLK	O	-	L	L	L	Expander (MC14094) control pin
45	P12/RXD2/IRQ2	VEXP_DATA	O	-	L	L	L	Expander (MC14094) control pin
46	VCC_USB	VCC_USB	-	-	-	-	-	Power supply pin
47	USB0_DM	USB0_DM	-	-	-	-	-	NC(open)
48	USB0_DP	USB0_DP	-	-	-	-	-	NC(open)
49	VSS_USB	VSS_USB	-	-	-	-	-	Ground pin
50	P56	TU_LA	O	-	L	L	L	TUNER control pin
51	P55/IRQ10	VEXP_STB	O	-	L	L	L	Expander (MC14094) control pin
52	P54	NET5V_POWER	O	-	L	L	L	Ethernet power supply (Net5V) control pin/
53	BCLK/P53	THERMAL_E	I	SW3VPu	I	L	I	Protection detect signal input pin (for Heat sink)
54	P52/RXD2	ADV7623_SPI_MI	I	-	L	L	L	HDMI transceiver w/ GUI(ADV7623) control pin (for GUI)
55	P51/SCK2	ADV7623_SPI_CLK	O	-	L	L	L	HDMI transceiver w/ GUI(ADV7623) control pin (for GUI)
56	P50/TXD2	ADV7623_SPI_MO	O	-	L	L	L	HDMI transceiver w/ GUI(ADV7623) control pin (for GUI)
57	VSS	VSS	-	-	-	-	-	Ground pin
58	P83	ARC_RST	O	-	L	L	L	Reset control pin for ARC IC
59	VCC	VCC	-	-	-	-	-	Power supply pin.

Pin	Pin Name	Symbol	I/O	Pu/Pd	STBY	STOP	CEC STBY	Function
60	PC7/TXD8/IRQ14	UB	I	Pd	-	-	-	Pins for setting the boot mode(select the Boot Mode or User Boot Mode)
61	PC6/RXD8/IRQ13	HSCL_(400k)	O	DV3VPu	L	L	L	HDMI transceiver w/ GUI(ADV7623) control pin (for HDMI)
62	PC5/SCK8	HSDA_(400k)	I_O	DV3VPu	L	L	L	HDMI transceiver w/ GUI(ADV7623) control pin (for HDMI)
63	P82/TXD10	DSP_MOSI	O	DA3VPu	L	L	L	DSP(ADI) control pin
64	P81/RXD10	DSP_MISO	I	DA3VPu	L	L	L	DSP(ADI) control pin
65	P80/SCK10	DSPI_CLK	O	DA3VPu	L	L	L	DSP(ADI) control pin
66	PC4/SCK5	DSP_IC5	O	DA3VPu	L	L	L	DSP(ADI) control pin
67	PC3/TXD5	M-DAX_LED	O		L	L	L	M-DAX LED control pin
68	P77/TXD11	DSP_RST	O		L	L	L	DSP(ADI) reset control pin
69	P76/RXD11	SEL_DATA	O		L	L	L	Audio selector control pin for NJU72750
70	PC2/RXD5	DA_POWER	O		L	L	L	Digital audio power supply (DA3.3V,DA1.2V) control pin
71	P75/SCK11	CEC_POWER2	O		L	L	H	CEC standby power control (for CEC Standby Mode 3)
72	P74	ADV7623_SPL_CS	O		L	L	L	HDMI transceiver w/ GUI(ADV7623) control pin (for GUI)
73	PC1/SCK5/IRQ12	DAC_PLD_ERR	I		L	L	L	Detect DAC/PLD error (from Audio PLD and DAC)
74	VCC	VCC	-		-	-	-	Power supply pin.
75	PC0/IRQ14	H/P_RL	O		L	L	L	Headphone relay control pin
76	VSS	VSS	-		-	-	-	Ground pin
77	P73	FRONT_RL	O		L	L	L	Speaker relay control pin
78	P87/TXD9	PSDA	I/O	CEC3VPu	O/L	L	L	HDMI I2C (MN864788/787) control pin
79	P86/RXD9	PSCL	I/O	CEC3VPu	O/L	L	L	HDMI I2C (MN864788/787) control pin
80	P85	SEL_CLK	O		L	L	L	Audio selector control pin for NJU72750
81	P84	APLD_CS	O		L	L	L	Audio PLD (5M570ZF256C5N) control pin
82	P83/SCK4/SCK6	APLD_DATA/DAC_DATA	O/O		L	L	L	Audio PLD (5M570ZF256C5N) control pin/DAC (AK4458VN) control pin
83	P82	APLD_CLK/DAC_CLK	O/O		L	L	L	Audio PLD (5M570ZF256C5N) control pin/DAC (AK4458VN) control pin
84	P81/TXD4/TXD6/IRQ4-DS	DAC_MS	O		L	L	L	DAC (AK4458VN) control pin
85	P72	DAC_RST	O		L	L	L	DAC (AK4458VN) control pin
86	P71	PRE_MUTE	O		L	L	L	MUTE for preout control pin
87	P80/RXD4/RXD6/IRQ12	ARC_INT	I	IOVc-c3VPu	L	L	L	ARC IC interrupt signal input pin
88	PA7	ISEL_A	I	SW3VPu	I	I	I	Input selector (Rotary encoder) signal input pin
89	PA6	ISEL_B	I	SW3VPu	I	I	I	Input selector (Rotary encoder) signal input pin
90	PA5	C/S_RL	O		L	L	L	Speaker relay control pin
91	VCC	VCC	-		-	-	-	Power supply pin.
92	PA4/TXD5/IRQ5-DS	RC_OUT	O		H	L	H	Remote code (RC-5) output pin
93	VSS	VSS	-		-	-	-	Ground pin
94	PA3/RXD5/IRQ6-DS	MVOL_DATA	O		L	L	L	Volume control pin (NJU72343)
95	PA2/RXD5	MVOL_CLK	O		L	L	L	Volume control pin (NJU72343)
96	PA1/MTIOC0B/IRQ11	FLASHER_IN(NA Only)/NC(Except NA)	I/O	Pd/-	I/L	I/L	I/L	Flasher (Remote) input pin (When standby mode,set to interrupt)
97	PA0	H5V_DET	I		I	I	I	HDMI IN 5V detect signal pin
98	P67/IRQ15	FL_CE	O		L	L	L	FL display control pin
99	P66	FL_DATA	O		L	L	L	FL display control pin
100	P65	FL_CLK	O		L	L	L	FL display control pin
101	PE7/IRQ7/AN105	KEY3	I	M3VPu	I	I	I	Key control signalinput pin (When standby mode,set to interrupt)
102	PE6/IRQ6/AN104	KEY2	I	M3VPu	I	I	I	Key control signalinput pin (When standby mode,set to interrupt)
103	VCC	VCC	-		-	-	-	Power supply pin.
104	P70	Hi-B_RL	O		L	L	L	HIGH-B relay control pin
105	VSS	VSS	-		-	-	-	Ground pin
106	PE5/IRQ5/AN103	KEY1	I	M3VPu	I	I	I	Key control signalinput pin (When standby mode,set to interrupt)

Pin	Pin Name	Symbol	I/O	Pu/Pd	STBY	STOP	CEC STBY	Function
107	PE4/AN102	DC_DET/ASO	I	SW3VPu	I	I	I	Protection detect signal input pin (for DC and ASO) (A/D converter)
108	PE3/AN101	AMPSIGDET	I	Pd	I	L	I	Signal level monitor pin (AD converter)
109	PE2/RXD12/IRQ7-DS/AN100	CURRENT_DET	I	Pd	I	L	I	Current level monitor pin (A/D converter)
110	PE1/TXD12	THERMAL_B	I	SW3VPu	I	L	I	Protection detect signal input pin
111	PE0/SCK12	NET3.3V_POWER	O		L	L	L	Ethernet power supply control(Net3.3V)
112	P64	DSV_POWER	O		L	L	H	Digital 5V power supply control pin(3.3V and 1.8V generate from 5V)(When CEC standby mode3,set to Low)
113	P63	CEC_POWER	O		L	L	H	CEC standby power supply control(CEC5V,CEC3.3V,CEC1.8V)(When CEC standby mode3,set to Low)
114	P62	DV_POWER1	O		L	L	L	Digital video power supply (DV5V,DV3.3V) control pin
115	P61	DIR_DOUT	I	DA3VPu	I	I	I	DIR (PCM9211) control pin
116	VSS	VSS	-		-	-	-	Ground pin
117	P60	DIR_DIN	O		L	L	L	DIR (PCM9211) control pin
118	VCC	VCC	-		-	-	-	Power supply pin.
119	PD7/IRQ7/AN107	H/P_DET/MIC_DET	I	SW3VPu	I	I	I	Headphone insert detect pin/Microphone insert detect pin (A/D converter)
120	PD6/IRQ6/AN106	MODE	I		I	I	I	Region setting pin
121	PD5/IRQ5/AN113	TU_RST	O		L	L	L	TUNER control
122	PD4/IRQ4/AN112	DIR_RST	O		L	L	L	DIR (PCM9211) control pin
123	PD3/IRQ3/AN111	MN864788_HINT	I	CEC3VPu	I	I	I	HDMI Tx (MN864788) interrupt signal input pin
124	PD2/IRQ2/AN110	MN864787_HINT	I	CEC3VPu	I	I	I	HDMI Rx (MN864787) interrupt signal det
125	PD1/IRQ1/AN109	TU_INT	I	SW3VPu	L	L	L	TUNER control
126	PD0/TIOCA7/IRQ0/AN108	CEC_IN	I	ST-BY3VPu	I	I	I	CEC-D control pin
127	P93/AN117	THERMAL_A	I	SW3VPu	I	L	I	Protection detect signal input pin
128	P92/RXD7/AN116	TEMP_SENSOR	I	NET3.3VPu	I	L	I	Temperature sensor input pin (for SRM)
129	P91/SCK7/AN115	KILL_IR	O		L	L	L	Front IR disable control pin
130	VSS	VSS	-		-	-	-	Ground pin
131	P90/TXD7/AN114	H5VOUT_POWER	O		L	L	L	HDMI 5V power supply control pin
132	VCC	VCC	-		-	-	-	Power supply pin.
133	P47/IRQ15-DS/AN007	FL_RST	O		L	L	L	FL display control pin
134	P46/IRQ14-DS/AN006	DIR_CE	O		L	L	L	DIR (PCM9211) control pin
135	P45/IRQ13-DS/AN005	DIR_CLK	O		L	L	L	DIR (PCM9211) control pin
136	P44/IRQ12-DS/AN004	AIOS4_STBY_STATUS	I		I	I	I	Not used (This port use to detect for Network Module standby status in the future (Low : normal, High : Deep Standby))
137	P43/IRQ11-DS/AN003	AIOS4_WAKEUP	O		L	L	L	same as NET5V_POWER,NET3.3V_POWER (This port use to control for Network Module standby mode in the future(Low : Deep Standby, High : normal))
138	P42/IRQ10-DS/AN002	CPU_POWER	O		L	L	L	CPU power supply control pin
139	P41/IRQ9-DS/AN001	MAIN_POWER	O		L	L	L	Power supply control pin
140	VREFLO	VREFLO	-		-	-	-	Ground pin
141	P40/IRQ8-DS/AN000	MN864788_HAINT	I	CEC3VPu	I	I	I	HDMI Tx (MN864788) interrupt signal input pin(for Audio)
142	VREFHO	VREFHO	-		-	-	-	Power supply pin
143	AVCCO	AVCCO	-		-	-	-	Power supply pin
144	P07/IRQ15	CEC_OUT	O		L	L	-	CEC-D control pin

# PCM9211 (DIGITAL : U1040)

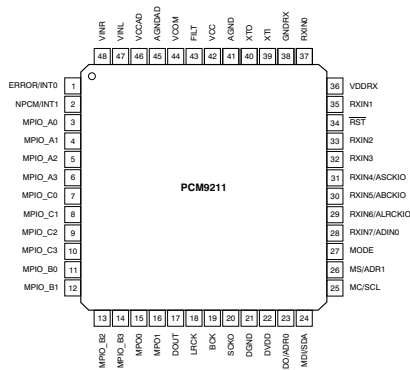

## PIN Functions

PIN				DESCRIPTION
NO.	NAME	I/O	5-V TOLERANT	
1	ERROR/INT0	O	No	DIR Error detection output / Interrupt0 output
2	NPCM/INT1	O	No	DIR Non-PCM detection output / Interrupt1 output
3	MPIO_A0	I/O	Yes	Multipurpose I/O, Group A(1)
4	MPIO_A1	I/O	Yes	Multipurpose I/O, Group A(1)
5	MPIO_A2	I/O	Yes	Multipurpose I/O, Group A(1)
6	MPIO_A3	I/O	Yes	Multipurpose I/O, Group A(1)
7	MPIO_C0	I/O	Yes	Multipurpose I/O, Group C(1)
8	MPIO_C1	I/O	Yes	Multipurpose I/O, Group C(1)
9	MPIO_C2	I/O	Yes	Multipurpose I/O, Group C(1)
10	MPIO_C3	I/O	Yes	Multipurpose I/O, Group C(1)
11	MPIO_B0	I/O	Yes	Multipurpose I/O, Group B(1)
12	MPIO_B1	I/O	Yes	Multipurpose I/O, Group B(1)
13	MPIO_B2	I/O	Yes	Multipurpose I/O, Group B(1)
14	MPIO_B3	I/O	Yes	Multipurpose I/O, Group B(1)
15	MPO0	O	No	Multipurpose output 0
16	MPO1	O	No	Multipurpose output 1
17	DOUT	O	No	Main output port, serial digital audio data output
18	LRCK	O	No	Main output port, LR clock output
19	BCK	O	No	Main output port, Bit clock output
20	SCKO	O	No	Main output port, System clock output
21	DGND	-	-	Ground, for digital
22	DVDD	-	-	Power supply, 3.3 V (typ.), for digital
23	MDO/ADRO	I/O	Yes	Software control I/F, SPI data output / I2C slave address setting0(2)
24	MDI/SDA	I/O	Yes	Software control I/F, SPI data input / I2C data input/output(2) (3)
25	MC/SCL	I	Yes	Software control I/F, SPI clock input / I2C clock input(2)

PIN				DESCRIPTION
NO.	NAME	I/O	5-V TOLERANT	
26	MS/ADR1	I	Yes	Software control I/F, SPI chip select / I2C slave address setting1(2)
27	MODE	I	No	Control mode setting, (see the Serial Control Mode section, Control Mode Pin Setting)
28	RXIN7/ADIN0	I	Yes	Biphase signal, input 7 / AUXIN0, serial audio data input(2)
29	RXIN6/ALRCKIO	I	Yes	Biphase signal, input 6 / AUXIN0, LR clock input(2)
30	RXIN5/ABCKIO	I	Yes	Biphase signal, input 5 / AUXIN0, bit clock input(2)
31	RXIN4/ASCKIO	I	Yes	Biphase signal, input 4 / AUXIN0, system clock input(2)
32	RXIN3	I	Yes	Biphase signal, input 3(2)
33	RXIN2	I	Yes	Biphase signal, input 2(2)
34	RST	I	Yes	Reset Input, active low(2) (4)
35	RXIN1	I	Yes	Biphase signal, input 1, built-in coaxial amplifier
36	VDDRX	-	-	Power supply, 3.3 V (typ.), for RXIN0 and RXIN1.
37	RXIN0	I	Yes	Biphase signal, input 0, built-in coaxial amplifier
38	GNDRX	-	-	Ground, for RXIN
39	XTI	I	No	Oscillation circuit input for crystal resonator or external XT1 clock source input(5)
40	XTO	O	No	Oscillation circuit output for crystal resonator
41	AGND	-	-	Ground, for PLL analog
42	VCC	-	-	Power supply, 3.3 V (typ.), for PLL analog
43	FILT	O	No	External PLL loop filter connection terminal; must connect recommended filter
44	VCOM	O	No	ADC common voltage output; must connect external decoupling capacitor
45	AGNDAD	-	-	Ground, for ADC analog
46	VCCAD	-	-	Power supply, 5.0 V (typ.), for ADC analog
47	VINL	I	No	ADC analog voltage input, left channel
48	VINR	I	No	ADC analog voltage input, right channel

- (1) Schmitt trigger input
- (2) Schmitt trigger input
- (3) Open-drain configuration in I2C mode
- (4) Onboard pull-down resistor (50 k Ω , typical)
- (5) CMOS Schmitt trigger input

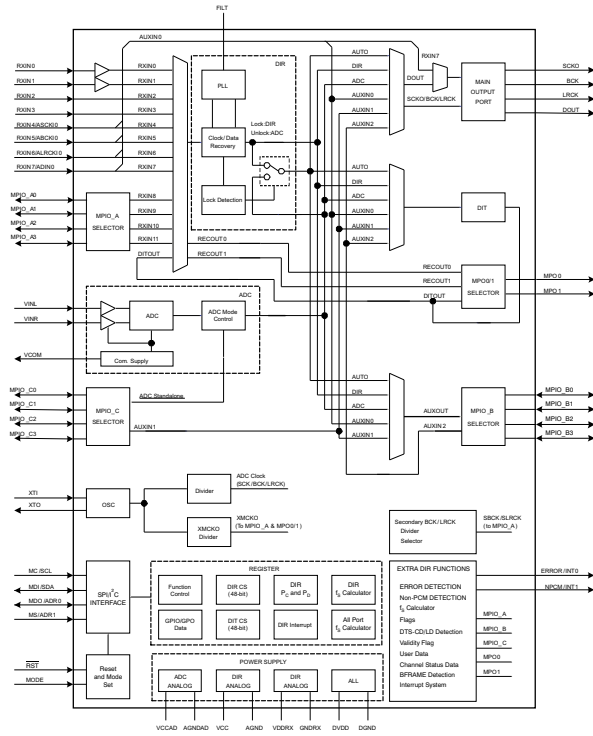

ADSP21487KSWZ-2B (DIGITAL : U1021)

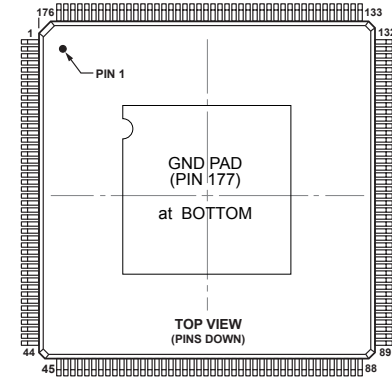

Pin Name	Pin No.	Pin Name	Pin No.	Pin Name	Pin No.	Pin Name	Pin No.
SDDQM	1	V <sub>DD_EXT</sub>	45	DAI_P10	89	V <sub>DD_INT</sub>	133
M50	2	DPI_P08	46	V <sub>DD_INT</sub>	90	FLAG0	134
SDCKE	3	DPI_P07	47	V <sub>DD_EXT</sub>	91	FLAG1	135
CLK_CFG1	4	V <sub>DD_INT</sub>	48	DAI_P20	92	FLAG2	136
ADDR0	5	DPI_P09	49	V <sub>DD_INT</sub>	93	NC	137
BOOT_CFG0	6	DPI_P10	50	DAI_P08	94	FLAG3	138
V <sub>DD_EXT</sub>	7	DPI_P11	51	DAI_P14	95	NC	139
ADDR1	8	DPI_P12	52	DAI_P04	96	NC	140
ADDR2	9	DPI_P13	53	DAI_P18	97	V <sub>DD_EXT</sub>	141
ADDR3	10	DAI_P14	54	DAI_P17	98	NC	142
ADDR4	11	DAI_P03	55	DAI_P16	99	V <sub>DD_INT</sub>	143
ADDR5	12	NC	56	DAI_P12	100	TRST	144
ADDR6	13	V <sub>DD_EXT</sub>	57	DAI_P15	101	NC	145
BOOT_CFG1	14	NC	58	V <sub>DD_INT</sub>	102	EMU	146
GND	15	NC	59	DAI_P11	103	DATA0	147
ADDR7	16	NC	60	V <sub>DD_EXT</sub>	104	DATA1	148
NC	17	NC	61	V <sub>DD_INT</sub>	105	DATA2	149
NC	18	V <sub>DD_INT</sub>	62	BOOT_CFG2	106	DATA3	150
NC	19	NC	63	V <sub>DD_INT</sub>	107	TD0	151
ADDR8	20	NC	64	AML_ACK	108	DATA4	152
ADDR9	21	V <sub>DD_INT</sub>	65	GND	109	V <sub>DD_EXT</sub>	153
CLK_CFG0	22	NC	66	THD_M	110	DATA5	154
V <sub>DD_INT</sub>	23	NC	67	THD_P	111	DATA6	155
CLKIN	24	V <sub>DD_INT</sub>	68	V <sub>DD_THD</sub>	112	V <sub>DD_INT</sub>	156
XTAL	25	NC	69	V <sub>DD_INT</sub>	113	DATA7	157
ADDR10	26	WDTRSTO	70	V <sub>DD_INT</sub>	114	TDI	158
SDA10	27	NC	71	TRST	115	SDCLK	159
V <sub>DD_EXT</sub>	28	V <sub>DD_INT</sub>	72	V <sub>DD_INT</sub>	116	V <sub>DD_INT</sub>	160
V <sub>DD_INT</sub>	29	DAI_P07	73	WDT_CLKO	117	DATA8	161
ADDR11	30	DAI_P13	74	WDT_CLKIN	118	DATA9	162
ADDR12	31	DAI_P19	75	V <sub>DD_EXT</sub>	119	DATA10	163
ADDR17	32	DAI_P01	76	ADDR23	120	TCK	164
ADDR13	33	DAI_P02	77	ADDR22	121	DATA11	165
V <sub>DD_INT</sub>	34	V <sub>DD_INT</sub>	78	ADDR21	122	DATA12	166
ADDR18	35	NC	79	V <sub>DD_INT</sub>	123	DATA14	167
RESETOUT/RUNRSTIN	36	NC	80	ADDR20	124	DATA13	168
V <sub>DD_INT</sub>	37	NC	81	ADDR19	125	V <sub>DD_INT</sub>	169
DPI_P01	38	NC	82	V <sub>DD_INT</sub>	126	DATA15	170
DPI_P02	39	NC	83	ADDR16	127	SDWE	171
DPI_P03	40	V <sub>DD_EXT</sub>	84	ADDR15	128	SDRAS	172
V <sub>DD_INT</sub>	41	V <sub>DD_INT</sub>	85	V <sub>DD_INT</sub>	129	RESET	173
DPI_P05	42	DAI_P06	86	ADDR14	130	TMS	174
DPI_P04	43	DAI_P05	87	AML_WR	131	SDCAS	175
DPI_P06	44	DAI_P09	88	AML_RD	132	V <sub>DD_INT</sub>	176
						GND	177*

\* at BOTTOM

Before Servicing  
This Unit

Electrical

Mechanical

Repair Information

Updating

# W9864G6KH-6(DIGITAL : U1020)

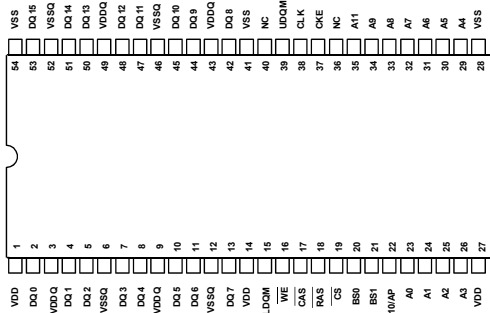

## Pin description

PIN NUMBER	PIN NAME	FUNCTION	DESCRIPTION
23 ~ 26, 22, 29 ~ 35	A0~A11	Address	Multiplexed pins for row and column address. Row address: A0~A11. Column address: A0~A7. A10 is sampled during a precharge command to determine if all banks are to be precharged or bank selected by BS0, BS1.
20, 21	BS0, BS1	Bank Select	Select bank to activate during row address latch time, or bank to read/write during address latch time.
2, 4, 5, 7, 8, 10, 11, 13, 42, 44, 45, 47, 48, 50, 51, 53	DQ0~DQ15	Data Input/ Output	Multiplexed pins for data output and input.
19	$\overline{CS}$	Chip Select	Disable or enable the command decoder. When command decoder is disabled, new command is ignored and previous operation continues.
18	$\overline{RAS}$	Row Address Strobe	Command input. When sampled at the rising edge of the clock $\overline{RAS}$ , $\overline{CAS}$ and $\overline{WE}$ define the operation to be executed.
17	$\overline{CAS}$	Column Address Strobe	Referred to $\overline{RAS}$
16	$\overline{WE}$	Write Enable	Referred to $\overline{RAS}$
39, 15	UDQM LDQM	Input/output mask	The output buffer is placed at Hi-Z (with latency of 2) when DQM is sampled high in read cycle. In write cycle, sampling DQM high will block the write operation with zero latency.
38	CLK	Clock Inputs	System clock used to sample inputs on the rising edge of clock.
37	CKE	Clock Enable	CKE controls the clock activation and deactivation. When CKE is low, Power Down mode, Suspend mode, or Self Refresh mode is entered.
1, 14, 27	VDD	Power	Power for input buffers and logic circuit inside DRAM.
28, 41, 54	VSS	Ground	Ground for input buffers and logic circuit inside DRAM.
3, 9, 43, 49	VDDQ	Power for I/O buffer	Separated power from VDD, to improve DQ noise immunity.
6, 12, 46, 52	VSSQ	Ground for I/O buffer	Separated ground from VSS, to improve DQ noise immunity.
36, 40	NC	No Connection	No connection.

## Block diagram

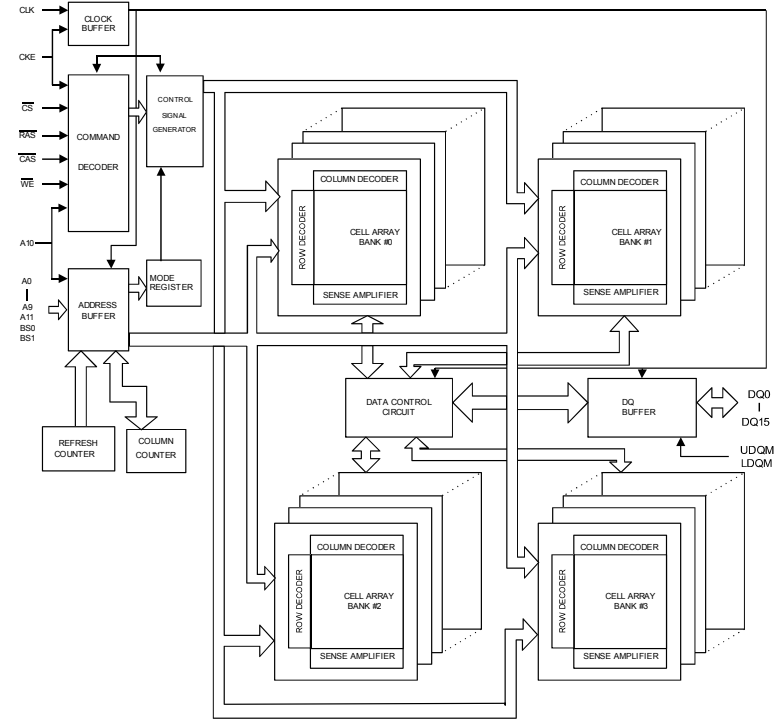

# AK4458VN (DIGITAL : U4601)

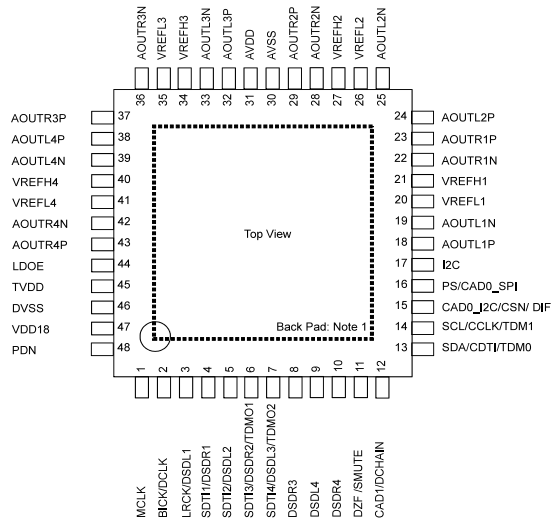

## Pin Function

No.	Pin Name	I/O	Function	PD State
1	MCLK	I	External Master Clock Input Pin	Hi-Z
2	BICK	I	Audio Serial Data Clock Pin in PCM mode	Hi-z
	DCLK	I	DSD Clock Pin in DSD mode	
3	LRCK	I	Input Channel Clock Pin in PCM mode	Hi-Z
	DSDL1	I	Audio Serial Data Input in DSD mode	
4	SDTI1	I	Audio Serial Data Input in PCM mode	Hi-Z
	DSDR1	I	Audio Serial Data Input in DSD mode	
5	SDTI2	I	Audio Serial Data Input in PCM mode	Hi-Z
	DSDL2	I	Audio Serial Data Input in DSD mode	
6	SDTI3	I	Audio Serial Data Input in PCM mode	100k Ω Pull down
	DSDR2	I	Audio Serial Data Input in DSD mode	
7	TDMO1	O	Audio Serial Data Output in Daisy Chain mode	100k Ω Pull down
	SDTI4	I	Audio Serial Data Input in PCM mode	
	DSDL3	I	Audio Serial Data Input in DSD mode	
8	TDMO2	O	Audio Serial Data Output in Daisy Chain mode	Hi-Z
	DSDR3	I	Audio Serial Data Input in DSD mode	
9	DSDL4	I	Audio Serial Data Input in DSD mode	Hi-Z
10	DSDR4	I	Audio Serial Data Input in DSD mode	Hi-Z
11	DZF	O	Zero Input Detect in I2C Bus or 3-wire serial control mode	100k Ω Pull down
	SMUTE	I	Soft Mute Pin in Parallel control mode. When this pin is changed to "H", soft mute cycle is initiated. When it is returning to "L", the output mute is released.	
12	CAD1	I	Chip Address 0 Pin in I C Bus or 3-wire serial control mode	Hi-Z
	DCHAIN	I	Daisy Chain Mode select pin in Parallel control mode.	
13	SDA	I/O	Control Data Pin in I2C Bus serial control mode	Hi-Z
	CDTI	I	Control Data Input Pin in 3-wire serial control mode	
14	TDM0	I	TDM Mode select pin in Parallel control mode.	Hi-Z
	SCL	I	Control Data Clock Pin in I2C Bus serial control mode	
	CCLK	I	Control Data Clock Pin in 3-wire serial control mode	
15	TDM1	I	TDM Mode select pin in Parallel control mode.	Hi-Z

No.	Pin Name	I/O	Function	PD State
15	CAD0_I2C	I	Chip Address 0 Pin in I2C Bus serial control mode	Hi-Z
	CSN	I	Chip Select Pin in 3-wire serial control mode	
	DIF	I	Audio Data Format Select in Parallel control mode. "L": 32-bit MSB, "H": 32-bit I2S	
16	PS	I	(I2C pin = "H") Control Mode Select Pin "L": I2C Bus serial control mode, "H": Parallel control mode.	Hi-Z
	CAD0_SPI	I	(I2C pin = "L") Chip Address 0 Pin in 3-wire serial control mode	
17	I2C	I	Control Mode Select Pin "L": 3-wire serial control mode "H": I2C Bus serial control mode or Parallel control mode.	Hi-Z
18	AOU1L1P	O	Lch Positive Analog Output 1 Pin	Hi-Z
19	AOU1L1N	O	Lch Negative Analog Output 1 Pin	Hi-Z
20	VREFL1	I	Negative Voltage Reference Input Pin, AVSS	Hi-Z
21	VREFH1	I	Positive Voltage Reference Input Pin, AVDD	Hi-Z
22	AOU1R1N	O	Rch Negative Analog Output 1 Pin	Hi-Z
23	AOU1R1P	O	Rch Positive Analog Output 1 Pin	Hi-Z
24	AOU2L2P	O	Lch Positive Analog Output 2 Pin	Hi-Z
25	AOU2L2N	O	Lch Negative Analog Output 2 Pin	Hi-Z
26	VREFL2	I	Negative Voltage Reference Input Pin, AVSS	Hi-Z
27	VREFH2	I	Positive Voltage Reference Input Pin, AVDD	Hi-Z
28	AOU2R2N	O	Rch Negative Analog Output 2 Pin	Hi-Z
29	AOU2R2P	O	Rch Positive Analog Output 2 Pin	Hi-Z
30	AVSS	-	Analog Ground Pin	-
31	AVDD	-	Analog Power Supply Pin, 3.0V-5.5V	-
32	AOU3L3P	O	Lch Positive Analog Output 3 Pin	Hi-Z
33	AOU3L3N	O	Lch Negative Analog Output 3 Pin	Hi-Z
34	VREFH3	I	Positive Voltage Reference Input Pin, AVDD	Hi-Z
35	VREFL3	I	Negative Voltage Reference Input Pin, AVSS	Hi-Z
36	AOU3R3N	O	Rch Negative Analog Output 3 Pin	Hi-Z
37	AOU3R3P	O	Rch Positive Analog Output 3 Pin	Hi-Z
38	AOU4L4P	O	Lch Positive Analog Output 4 Pin	Hi-Z
39	AOU4L4N	O	Lch Negative Analog Output 4 Pin	Hi-Z
40	VREFH4	I	Positive Voltage Reference Input Pin, AVDD	Hi-Z
41	VREFL4	I	Negative Voltage Reference Input Pin, AVSS	Hi-Z
42	AOU4R4N	O	Rch Negative Analog Output 4 Pin	Hi-Z
43	AOU4R4P	O	Rch Positive Analog Output 4 Pin	Hi-Z
44	LDOE	I	Internal LDO Enable Pin. "L": Disable, "H": Enable	Hi-Z
45	TVDD	-	Digital Power Supply Pin, 3.0V-3.6V	-
46	DVSS	-	Digital Ground Pin	-
47	VDD18	O	LDO Output Pin (LDOE pin = "H") This pin should be connected to DVSS with 1.0μF.	(Note 4)
		I	1.8V Power Input Pin (LDOE pin = "L")	
48	PDN	I	Power-Down & Reset Pin When this pin is "L", the AK4458 is powered-down and the control registers are reset to default state.	Hi-Z

Note 2. All input pins except internal pull-up/down pins should not be left floating.  
 Note 3. PCM mode and DSD mode are controlled by registers. Daisy Chain mode is controlled by both registers and pins.  
 Note 4. This pin outputs DVSS when the LDOE pin = "H" and Hi-z when the LDOE pin = "L".

FUNCTIONAL BLOCK DIAGRAM

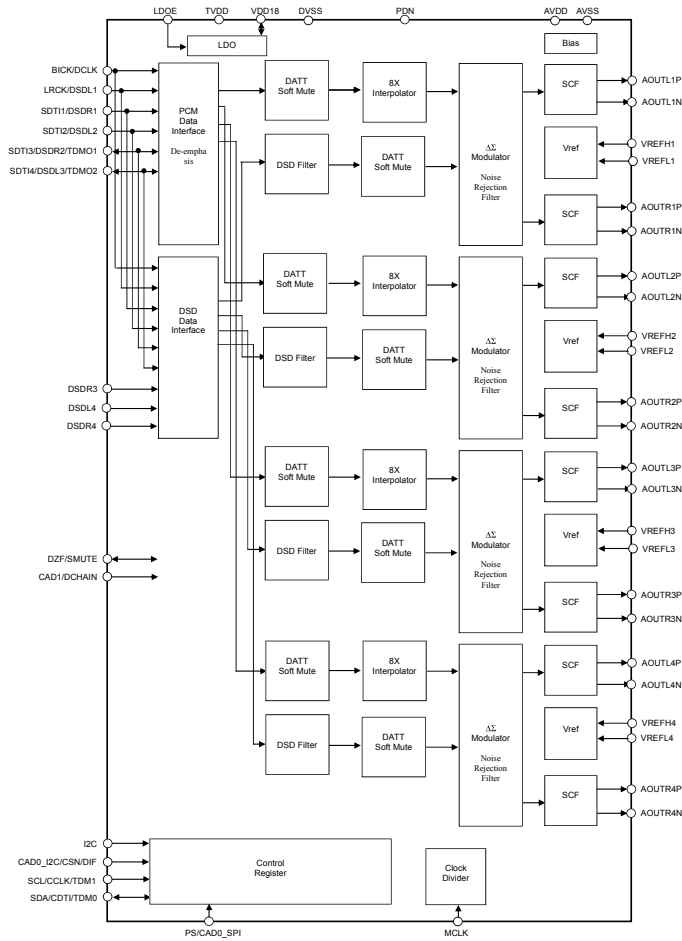

PCM5100A (DIGITAL : U1052)

PCM510X (top view)

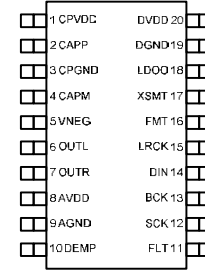

Table 2. TERMINAL FUNCTIONS, PCM510x

TERMINAL NAME	NO.	I/O	DESCRIPTION
CPVDD	1	-	Charge pump power supply, 3.3V
CAPP	2	O	Charge pump flying capacitor terminal for positive rail
CPGND	3	-	Charge pump ground
CAPM	4	O	Charge pump flying capacitor terminal for negative rail
VNEG	5	O	Negative charge pump rail terminal for decoupling, -3.3V
OUTL	6	O	Analog output from DAC left channel
OUTR	7	O	Analog output from DAC right channel
AVDD	8	-	Analog power supply, 3.3V
AGND	9	-	Analog ground
DEMP	10	I	De-emphasis control for 44.1kHz sampling rate <sup>(1)</sup> : Off (Low) / On (High)
FLT	11	I	Filter select : Normal latency (Low) / Low latency (High)
SCK	12	I	System clock input
BCK	13	I	Audio data bit clock input
DIN	14	I	Audio data input
LRCK	15	I	Audio data word clock input
FMT	16	I	Audio format selection : I <sup>2</sup> S (Low) / Left justified (High)
XSMT	17	I	Soft mute control : Soft mute (Low) / soft un-mute (High)
LDOO	18	-	Internal logic supply rail terminal for decoupling
DGND	19	-	Digital ground
DVDD	20	-	Digital power supply, 3.3V

PCM5100 Block Diagram

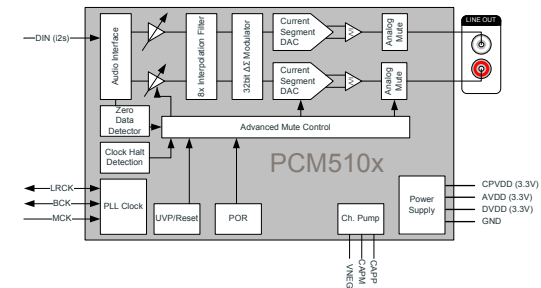

Figure 1. PCM510x Functional Block Diagram

Before Servicing This Unit

Electrical

Mechanical

Repair Information

Updating

## NJU72343 (AV : U5202)

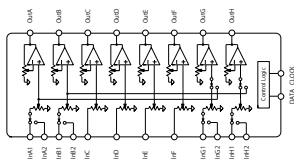

### Pin Function

No.	Symbol	Function	No.	Symbol	Function
1	AREF	Analog reference potential terminal	17	DATA	IC control data input
2	ADR	Address selection terminal	18	CLOCK	IC control clock input
3	InA2	Ach input2	19	VDDOUT	Digital power supply output terminal
4	InB2	Bch input2	20	AREF	Analog reference potential terminal
5	InA1	Ach input1	21	OutH	Hch output
6	InB1	Bch input1	22	OutG	Gch output
7	InC	Cch input	23	OutF	Fch output
8	InD	Dch input	24	OutE	Ech output
9	InE	Ech input	25	OutD	Dch output
10	InF	Fch input	26	OutC	Cch output
11	InG1	Gch input1	27	OutB	Bch output
12	InH1	Hch input1	28	OutA	Ach output
13	InG2	Cch input2	29	AREF	Analog reference potential terminal
14	InH2	Dch input2	30	V-	negative power supply terminal
15	MUTE	External mute control terminal	31	AREF	Analog reference potential terminal
16	REF	Digital reference potential terminal	32	V+	positive power supply terminal

## NJU72750A (AV : U5201)

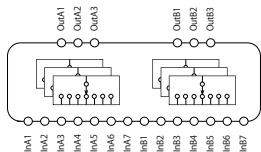

### Pin Function

No.	Symbol	Function	No.	Symbol	Function
1	V+	positive power supply terminal	17	DATA	IC control data input
2	InA1	Ach input1	18	CLOCK	IC control clock input
3	InB1	Bch input1	19	NC	-
4	InA2	Ach input2	20	NC	-
5	InB2	Bch input2	21	OutB3	Bch output3
6	InA3	Ach input3	22	OutA3	Ach output3
7	InB3	Bch input3	23	REF_B	Bch reference potential terminal
8	InA4	Ach input4	24	OutB2	Bch output2
9	InB4	Bch input4	25	OutA2	Ach output2
10	InA5	Ach input5	26	REF_A	Ach reference potential terminal
11	InB5	Bch input5	27	OutB1	Bch output1
12	InA6	Ach input6	28	OutA1	Ach output1
13	InB6	Bch input6	29	NC	-
14	InA7	Ach input7	30	ADR0	Address selection pin 0
15	InB7	Bch input7	31	ADR1	Address selection pin 1
16	REF	Reference potential terminal for BIAS	32	V-	negative power supply terminal

## NJM2595MTE1 (AV : U5206)

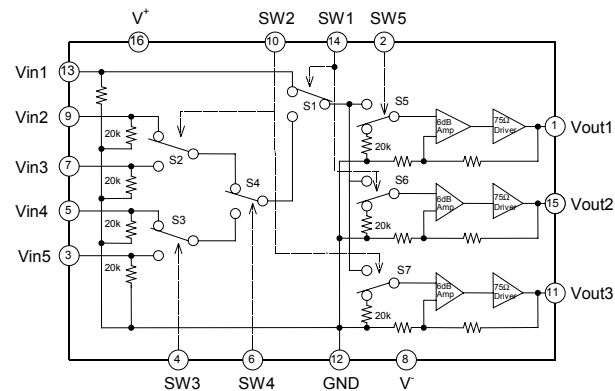

Before Servicing  
This Unit

Electrical

Mechanical

Repair Information

Updating



## 2. FL DISPLAY

### FLD (CIG25-1801N) (FRONT : U4400)

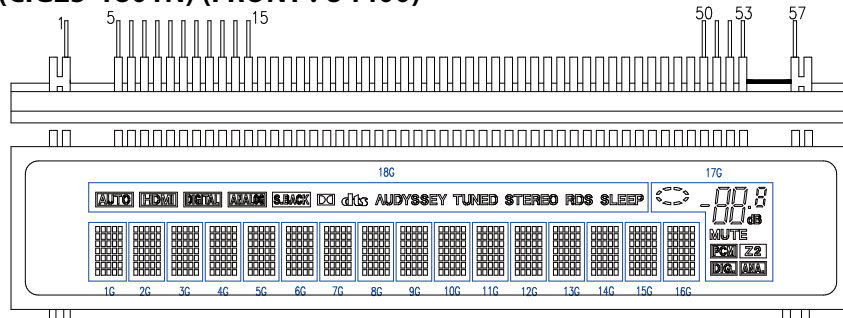

(1G~16G)

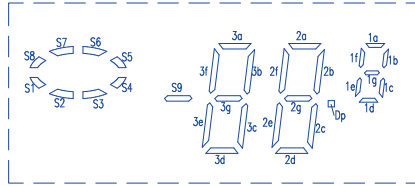

17G

#### PIN CONNECTION

CONNECTION	PIN NO.
F1	1
NP	2
NP	3
NP	4
LGND	5
PGND	6
VH	7
VDD	8
OSC	9
RESET	10
CS	11
CP	12
DA	13
TSA	14
TSB	15
NX	16-49
18G	50
17G	51
Q17G	52
Q18G	53
NP	54
NP	55
NP	56
F2	57

#### NOTE

- 1) F1, F2 ----Filament
- 2) NP -----No pin
- 3) NX -----No extend pin
- 4) LGND ----Logic GND pin
- 5) PGND ----Power GND pin
- 6) VH -----High Voltage Supply pin
- 7) VDD -----Logic Voltage Supply pin
- 8) CP ----Shift Register Clock
- 9) DA ----Serial Data Input
- 10) TSA, B --Test pin
- 11) OSC ----Pin for self-oscillation
- 12) 17G, 18G ---Grid
- 13) Q17G, Q18G ---Driver Output Port.

#### ANODE CONNECTION

	1G	2G	3G	4G	5G	6G	7G	8G	9G	10G	11G	12G	13G	14G	15G	16G	17G(AD3)	18G(AD4)
SEGA1	1	1	1	1	1	1	1	1	1	1	1	1	1	1	1	1	S9	-
SEGA2	2	2	2	2	2	2	2	2	2	2	2	2	2	2	2	2	3d	-
SEGA3	3	3	3	3	3	3	3	3	3	3	3	3	3	3	3	3	2d	-
SEGA4	4	4	4	4	4	4	4	4	4	4	4	4	4	4	4	4	3e	-
SEGA5	5	5	5	5	5	5	5	5	5	5	5	5	5	5	5	5	2e	-
SEGA6	6	6	6	6	6	6	6	6	6	6	6	6	6	6	6	6	3c	-
SEGA7	7	7	7	7	7	7	7	7	7	7	7	7	7	7	7	7	2c	-
SEGA8	8	8	8	8	8	8	8	8	8	8	8	8	8	8	8	8	3g	-
SEGA9	9	9	9	9	9	9	9	9	9	9	9	9	9	9	9	9	2g	-
SEGA10	10	10	10	10	10	10	10	10	10	10	10	10	10	10	10	10	3f	-
SEGA11	11	11	11	11	11	11	11	11	11	11	11	11	11	11	11	11	2f	-
SEGA12	12	12	12	12	12	12	12	12	12	12	12	12	12	12	12	12	3b	-
SEGA13	13	13	13	13	13	13	13	13	13	13	13	13	13	13	13	13	2b	-
SEGA14	14	14	14	14	14	14	14	14	14	14	14	14	14	14	14	14	3a	-
SEGA15	15	15	15	15	15	15	15	15	15	15	15	15	15	15	15	15	2a	-
SEGA16	16	16	16	16	16	16	16	16	16	16	16	16	16	16	16	16	Dp	-
SEGA17	17	17	17	17	17	17	17	17	17	17	17	17	17	17	17	17	dB	-
SEGA18	18	18	18	18	18	18	18	18	18	18	18	18	18	18	18	18	1d	-
SEGA19	19	19	19	19	19	19	19	19	19	19	19	19	19	19	19	19	1e	-
SEGA20	20	20	20	20	20	20	20	20	20	20	20	20	20	20	20	20	1c	-
SEGA21	21	21	21	21	21	21	21	21	21	21	21	21	21	21	21	21	1g	-
SEGA22	22	22	22	22	22	22	22	22	22	22	22	22	22	22	22	22	1f	-
SEGA23	23	23	23	23	23	23	23	23	23	23	23	23	23	23	23	23	1b	-
SEGA24	24	24	24	24	24	24	24	24	24	24	24	24	24	24	24	24	1a	AUTO
SEGA25	25	25	25	25	25	25	25	25	25	25	25	25	25	25	25	25	S1	HDMI
SEGA26	26	26	26	26	26	26	26	26	26	26	26	26	26	26	26	26	S2	DIGITAL
SEGA27	27	27	27	27	27	27	27	27	27	27	27	27	27	27	27	27	S3	ANALOG
SEGA28	28	28	28	28	28	28	28	28	28	28	28	28	28	28	28	28	S4	S.BACK
SEGA29	29	29	29	29	29	29	29	29	29	29	29	29	29	29	29	29	S5	DI
SEGA30	30	30	30	30	30	30	30	30	30	30	30	30	30	30	30	30	S6	dts
SEGA31	31	31	31	31	31	31	31	31	31	31	31	31	31	31	31	31	S7	AUDYSSEY
SEGA32	32	32	32	32	32	32	32	32	32	32	32	32	32	32	32	32	S8	TUNED
SEGA33	33	33	33	33	33	33	33	33	33	33	33	33	33	33	33	33	MUTE	STEREO
SEGA34	34	34	34	34	34	34	34	34	34	34	34	34	34	34	34	34	PCM	RDS
SEGA35	35	35	35	35	35	35	35	35	35	35	35	35	35	35	35	35	FZ	SLEEP
AD1	-	-	-	-	-	-	-	-	-	-	-	-	-	-	-	-	DIG.	-
AD2	-	-	-	-	-	-	-	-	-	-	-	-	-	-	-	-	ANA.	-







Internet Radio Recent Played Station	27	53	52	27 53 52	RCRC52705352	---	---	
Network: Favorite Direct Play	27	53	63	27 53 63	RCRC52705363	---	---	
Network(DMP): Stop	27	54	03	27 54 03	RCRC52705403	---	---	
Network(DMP): Cursor Up	27	80	03	27 80 03	RCRC52708003	---	---	
Network(DMP): Cursor Down	27	81	03	27 81 03	RCRC52708103	---	---	
Network(DMP): Cursor Left	27	85	03	27 85 03	RCRC52708503	---	---	
Network(DMP): Cursor Right	27	86	03	27 86 03	RCRC52708603	---	---	
Network(DMP): Enter	27	87	03	27 87 03	RCRC52708703	---	---	
Network(DMP): Back(Return)	27	83	03	27 83 03	RCRC52708303	---	---	
Network(DMP):HOME	27	88	02	27 88 02	RCRC52708802	---	---	
Page Previous	27	93	13	27 93 13	RCRC52709313	---	---	
Page Next	27	93	14	27 93 14	RCRC52709314	---	---	

Notes: Specifications subject to change without prior notice.

X	The command is available for the model.
---	The command is NOT available for the model.

- \*1 Main room commands work as Multi room commands when the Multi room RC-IN input was used.  
These commands are recognized as for Main room(zone) commands when they are received via Front IR receiver or Rear Remote Control In.  
These commands are recognized as for Multi room(zone) commands when they are received via Rear Multi room Remote In.
- \*2 Need an input assign to the input in Menu in advance the use
- \*4 /U1x version (for North America) model only
- \*5 /N1x version (for Europe) model only
- \*6 /U1x (for North America), /N1x version (for Europe) model only
- \*7 The RC code can be sent using RS-232C/IP Serial protocol commands

#### Revision

18-Mar-19 V01 Issued NR1510/1710

## DISASSEMBLY

### Flowchart

1. FRONT PANEL ASSY

2. RADIATOR ASSY

3. DIGITAL PCB

4. SPK PCB

5. TRANS

6. SMPS PCB

7. REG PCB

8. AV PCB

## EXPLODED VIEW

## PACKAGING VIEW

## Flowchart

- Remove each part following the flow below.
- Reassemble the removed parts in the reverse order.
- Read "[SAFETY PRECAUTIONS](#)" before reassembling the removed parts.
- If wire bundles are removed or moved during adjustment or part replacement, reshape the wires after completing the work. Failure to shape the wires correctly may cause problems such as noise.
- See "[EXPLODED VIEW](#)"

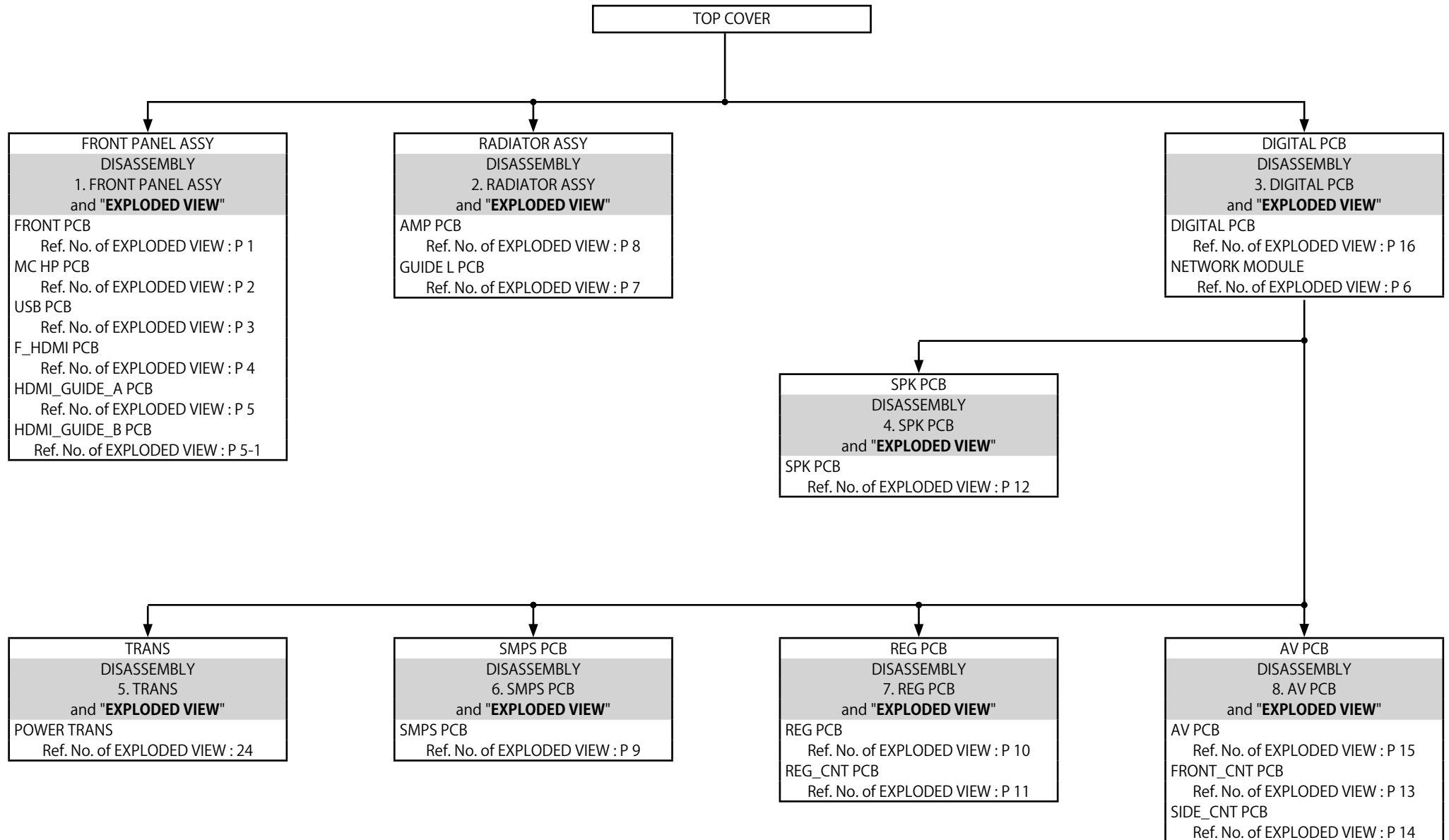

## Explanatory Photos for DISASSEMBLY

- For the shooting direction of each photos used in this manual, see the photo below.
- **A, B, C and D** in the photo below indicate the shooting directions of photos.
- The photographs with no shooting direction indicated were taken from the top of the unit.
- Photos of NR1510 U are used in this manual.

### The viewpoint of each photograph

(Shooting direction : X) [View from the top]

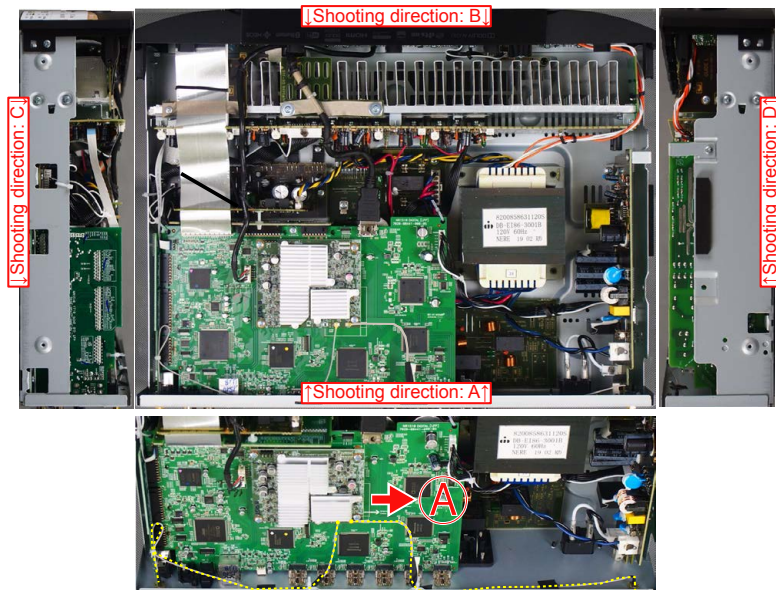

#### Attention :

When reinserting the Antenna Cable after it has been disconnected, make sure it is facing the direction shown in Ⓐ above.

## 1. FRONT PANEL ASSY

Proceeding : **TOP COVER** → **FRONT PANEL ASSY**

(1) Remove the screws.

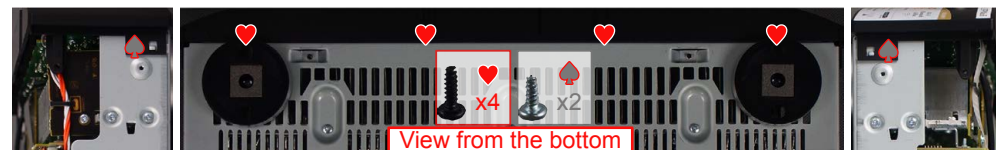

(2) Remove the screws. Remove the CORD HOLDER and connectors. Remove the FFC.

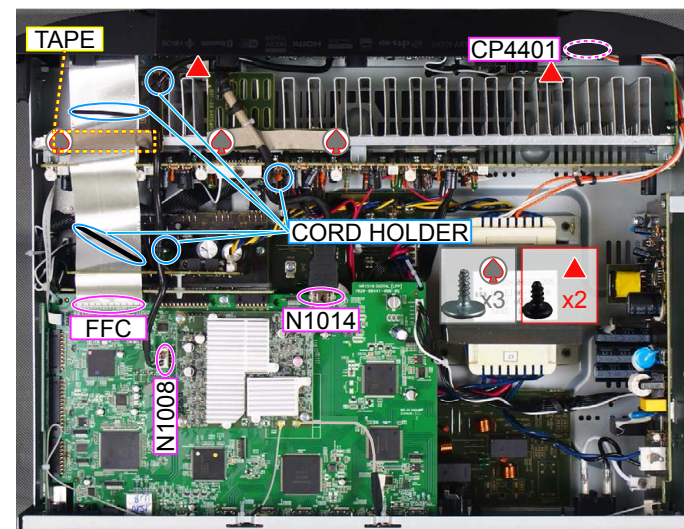



## 2. RADIATOR ASSY

Proceeding : **TOP COVER** → **RADIATOR ASSY**

(1) Remove the screws.



(2) Remove the screws. Remove the CORD HOLDER and connectors. Remove the FFC. Remove the TAPE.

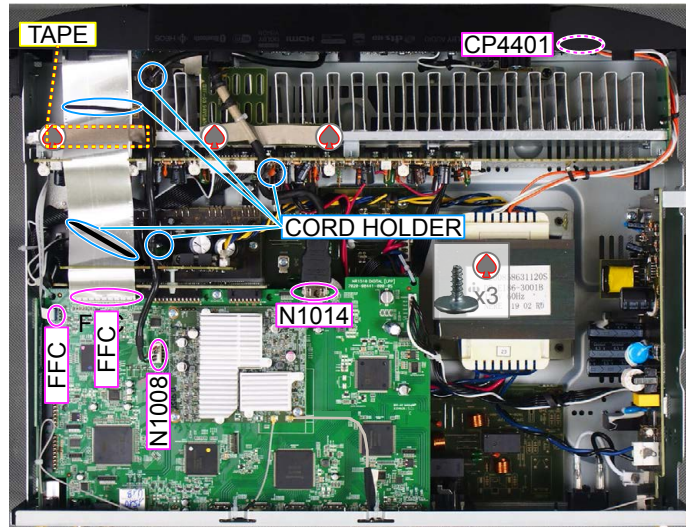

(3) Remove the CORD HOLDERS and connectors.

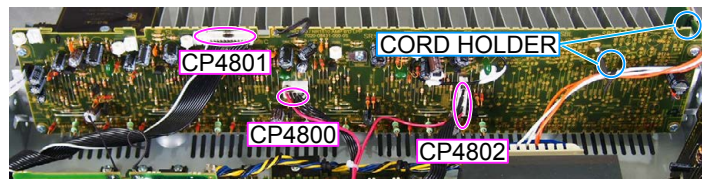

## 3. DIGITAL PCB

Proceeding : **TOP COVER** → **DIGITAL PCB**

(1) Remove the screws.



(2) Cut the wire clamp, then remove the connector. Remove the FFC.

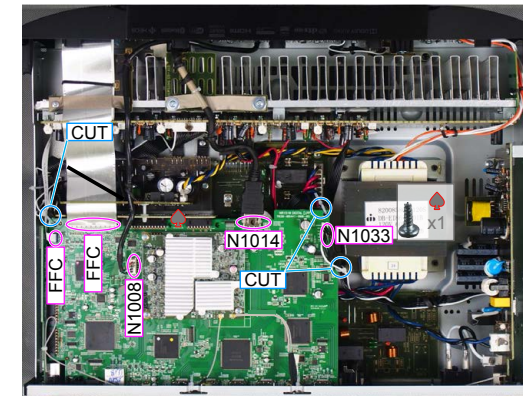

(3) Remove the connector.

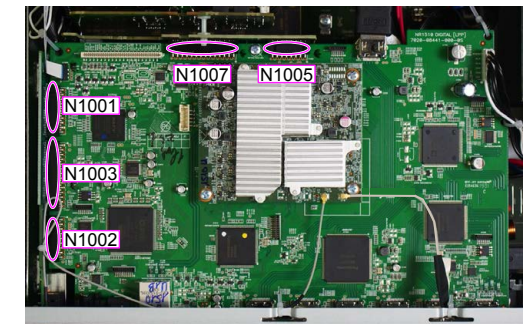

## 4. SPK PCB

Proceeding : **TOP COVER** → **DIGITAL PCB** → **SPK PCB**

(1) Remove the screws.



(2) Remove the screws. Remove the CORD HOLDER and connectors. Remove the HOLDER.

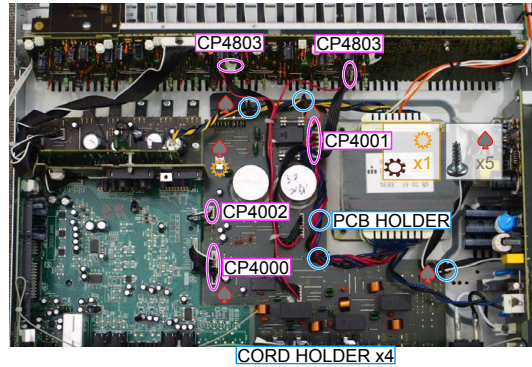

## 5. TRANS

Proceeding : **TOP COVER** → **DIGITAL PCB** → **TRANS**

(1) Remove the CORD HOLDERS and connector wires.

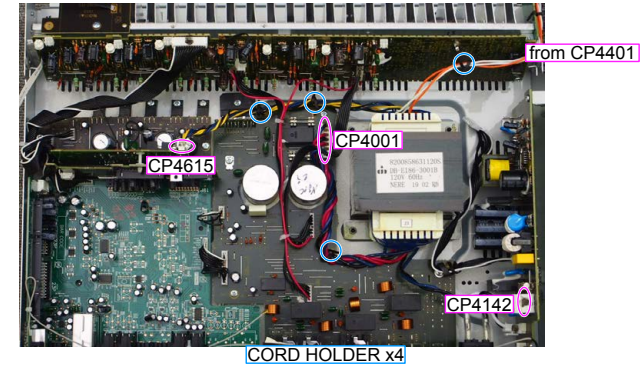

(2) Remove the screws.

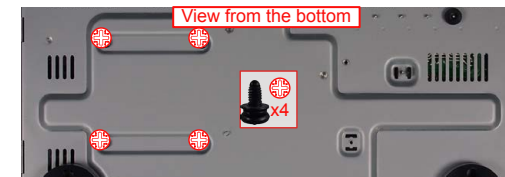

NOTE : It will separate and TRANS will fall from SET, if screws is removed.

## 6. SMPS PCB

Proceeding : **TOP COVER** → **SMPS PCB**

See "[EXPLODED VIEW](#)" for instructions on removing the SMPS PCB.

## 7. REG PCB

Proceeding : **TOP COVER** → **REG PCB**

See "[EXPLODED VIEW](#)" for instructions on removing the REG PCB.

## 8. AV PCB

Proceeding : **TOP COVER** → **DIGITAL PCB** → **AV PCB**

See "[EXPLODED VIEW](#)" for instructions on removing the AV PCB.

# EXPLODED VIEW

Parts List : <http://dmedia.dmglobal.com/Document/DocumentDetails/25778>

## NR1510/1710(Marantz) EXPLODE VIEW

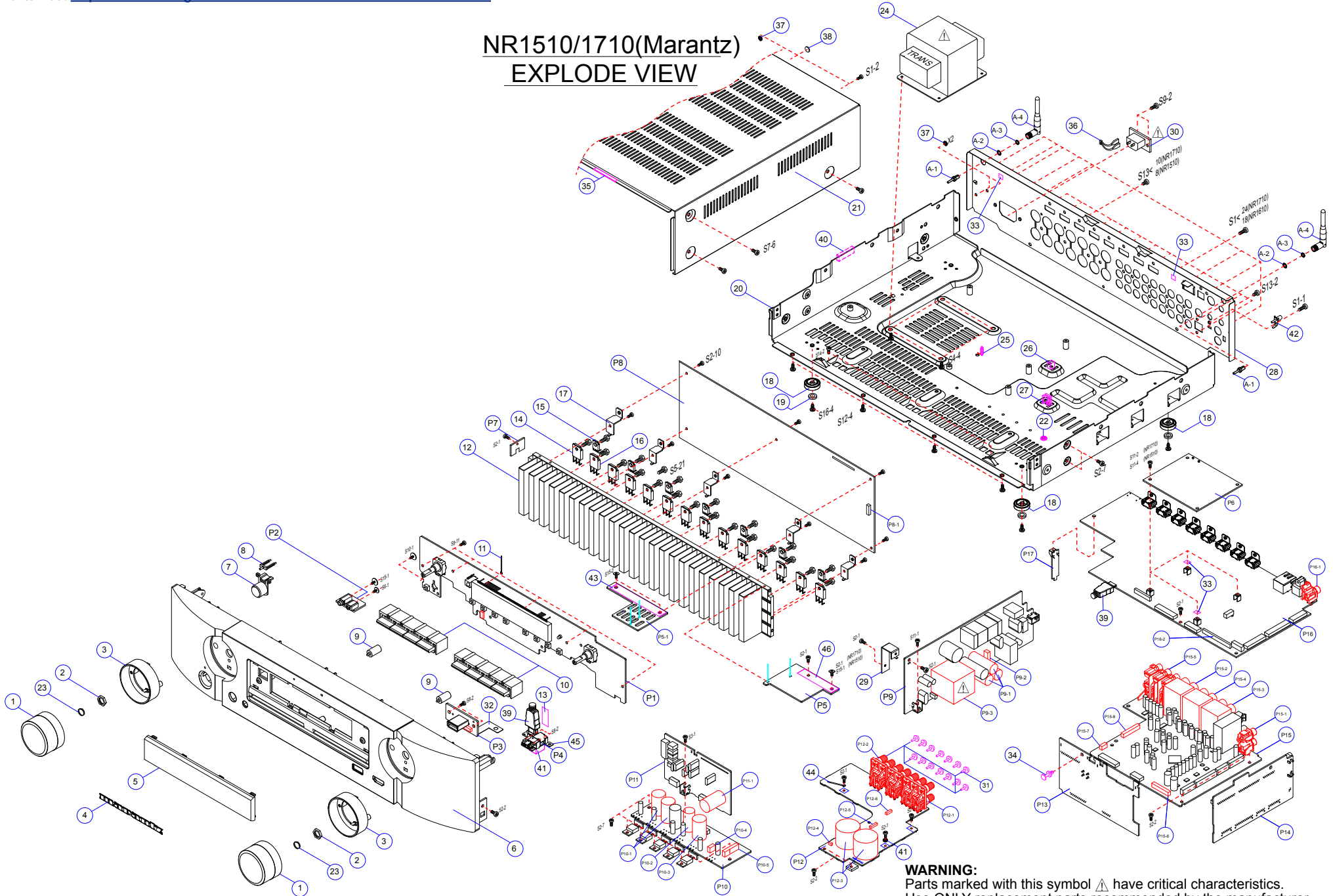

**WARNING:**  
Parts marked with this symbol  have critical characteristics.  
Use ONLY replacement parts recommended by the manufacturer.

Before Servicing  
This Unit

Electrical

Mechanical

Repair Information

Updating

# PACKAGING VIEW

Parts List : <http://dmedia.dmglobal.com/Document/DocumentDetails/25778>

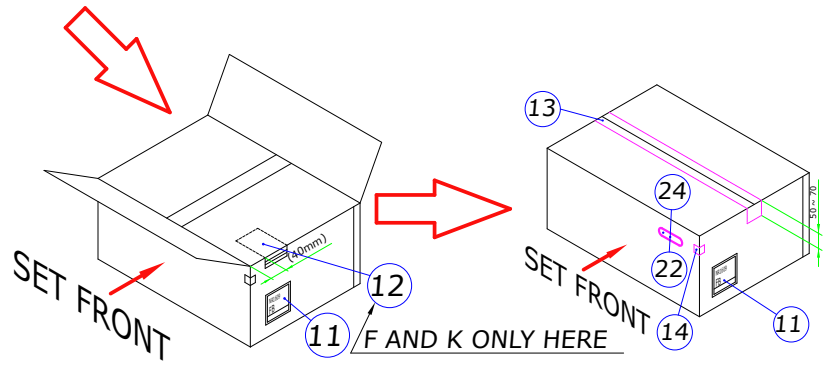
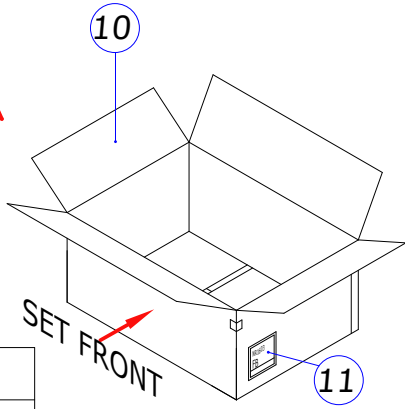
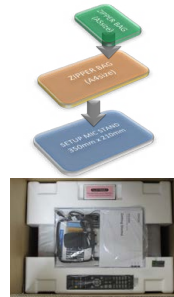
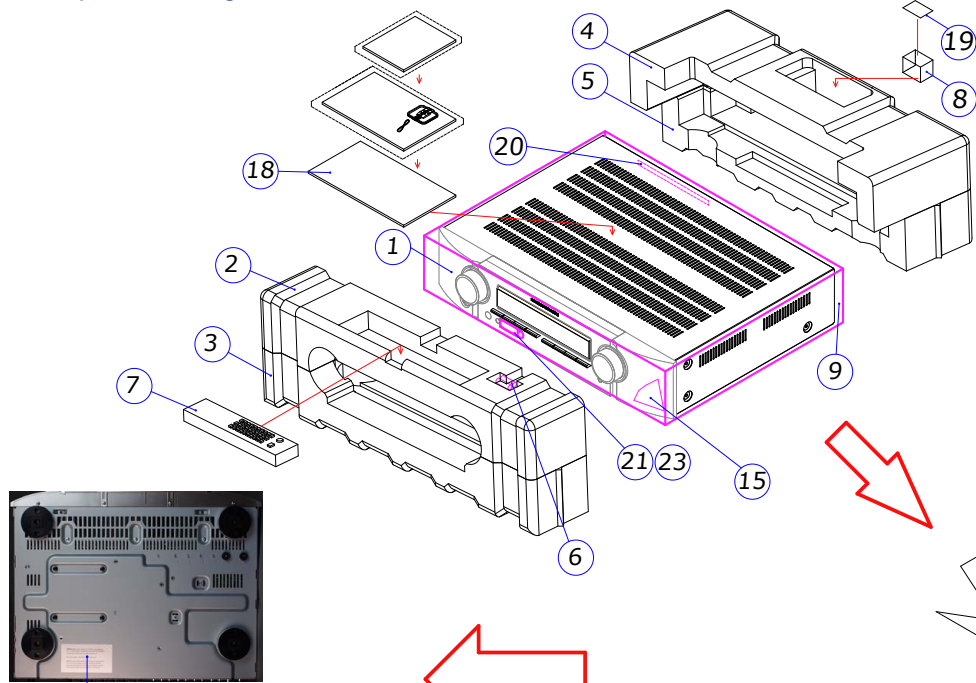

*MANUAL POLYBAG ASSY*		*MIC ASSY*	
POLYBAG CODE: 6337-04006-201-0S		POLYBAG CODE: 6330-21071-900-0S	
<p>26 ZIPPERBAG(A4size)</p> <p>27 Notes on RADIO (ALL)</p> <p>28 Caution on Using Batteries (N Only)</p> <p>29 SAFETY INST. (ALL)</p> <p>30 MAINLY (U Only)</p> <p>31 SPK WIRE LABEL (ALL)</p> <p>32 ZIPPERBAG(SIZE: 100x140mm)</p> <p>33 TV Antenna</p> <p>34 All Antenna</p> <p>35 Bluetooth</p> <p>36 W/FI</p> <p>37 CARD PASS (U Only)</p> <p>38 ZIPPERBAG(A5size)</p> <p>39 Set the speaker (N Only)</p> <p>40 JAWA insertion sheet (U Only)</p> <p>41 SPOTBY insertion sheet (U Only)</p> <p>42 JAPAN HOST CARD (U Only)</p> <p>43 QUICK START GUIDE (ALL)</p>	<p>18-1 18 SETUP MIC STAND</p> <p>19 SIZE: 355mm x 210mm</p> <p>This part together with document and zipper bag are supplied.</p> <p>MIC STAND ASSEMBLY INSTRUCTIONS</p>		

* POLY BAG PACKING STYLE	* BOX BOTTOM TAPE( O )	* BOX BOTTOM CLIP( X )
<p>TAPE(Yellow)</p> <p>16</p> <p>CORD AC</p> <p>OLNY UK PLUG(at store)</p>	<p>13</p>	

Before Servicing This Unit  
 Electrical  
 Mechanical  
 Repair Information  
 Updating

# REPAIR INFORMATION

## TROUBLE SHOOTING

1. POWER
2. Analog video
3. HDMI/DVI
4. AUDIO
5. Network / Bluetooth / USB
6. SMPS

## HDMI "Rx/Tx" Failure Detection

1. Prior checking
2. Preparations for checking HDMI Switcher reception/transmission register
3. Starting detecting the point of failure
4. Device implementation location

## CLOCK FLOW & WAVE FORM IN DIGITAL BLOCK

## SPECIAL MODE

Special mode setting button

1. Version Display Mode
2. PANEL / REMOTE LOCK Selection Mode
- 3-1. Selecting the Mode for Service-related
- 3-2. Protection History Display Mode
- 3-3. Operation Info Mode
- 3-4. TUNER STEP mode (U / N only)
4. Protection Pass Mode
5. Network Initialization Mode
6. Clearing the Operation Info
7. Log Capture feature

## DIAGNOSTIC MODE

Service Path Check Mode  
DIAGNOSTIC PATH DIAGRAM

## JIG FOR SERVICING

## ADJUSTMENT

# TROUBLE SHOOTING

## 1. POWER

### 1.1. The unit does not power on

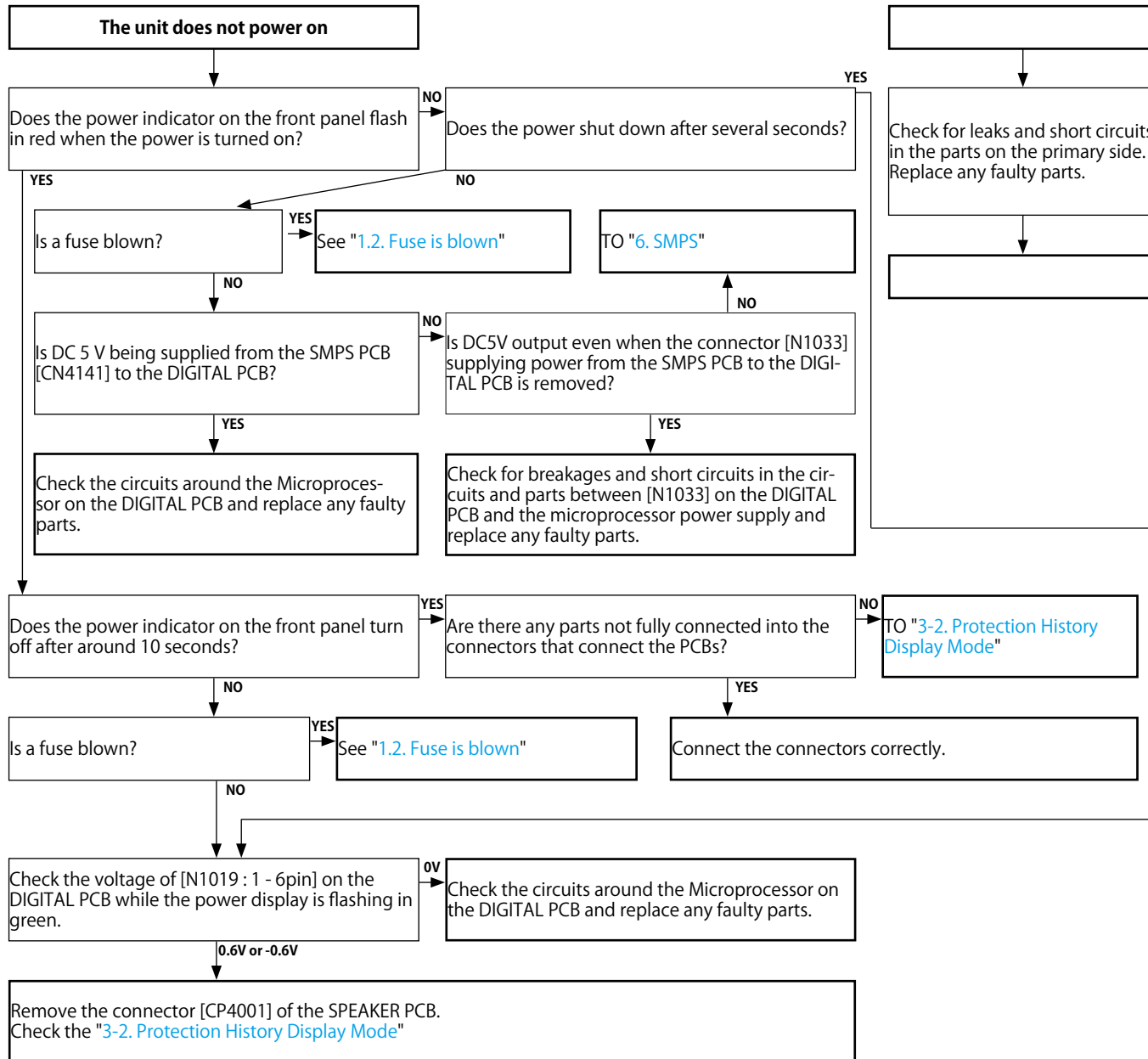

### 1.2. Fuse is blown

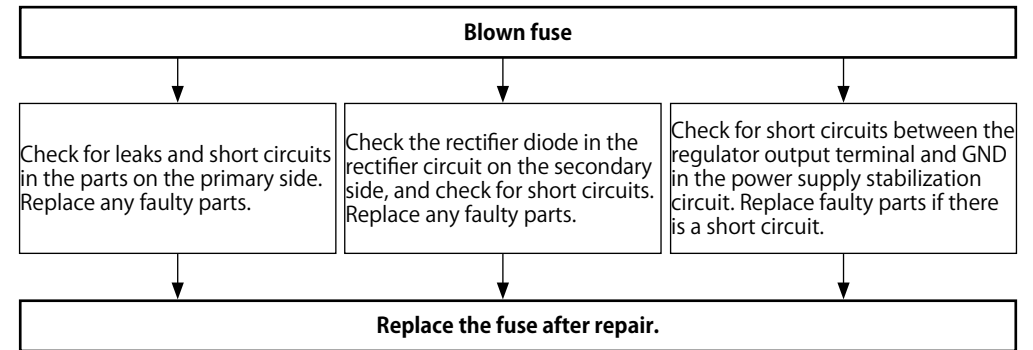

Before Servicing This Unit

Electrical

Mechanical

Repair Information

Updating

## 2. Analog video

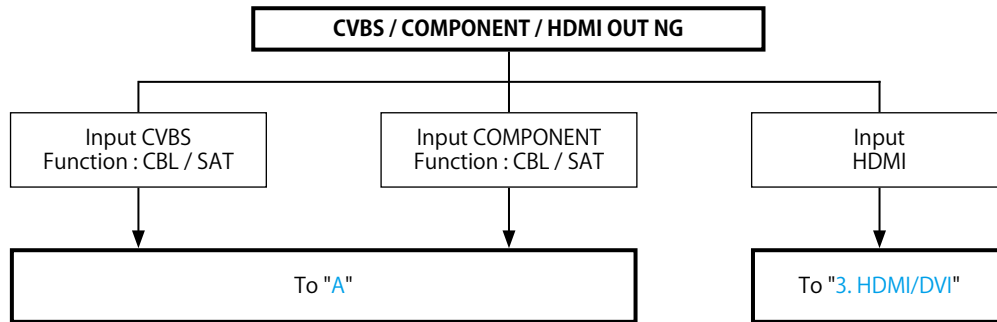

### DIGITAL test point

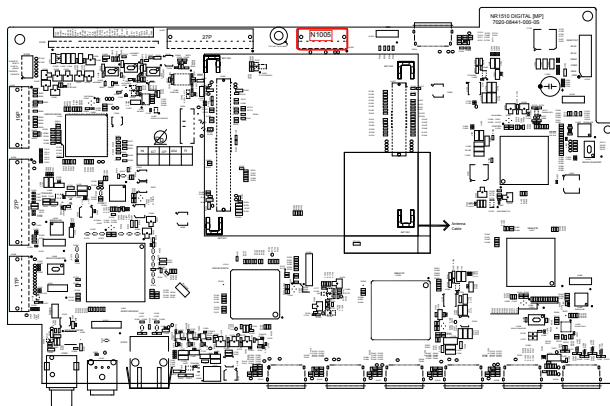

### AV test point

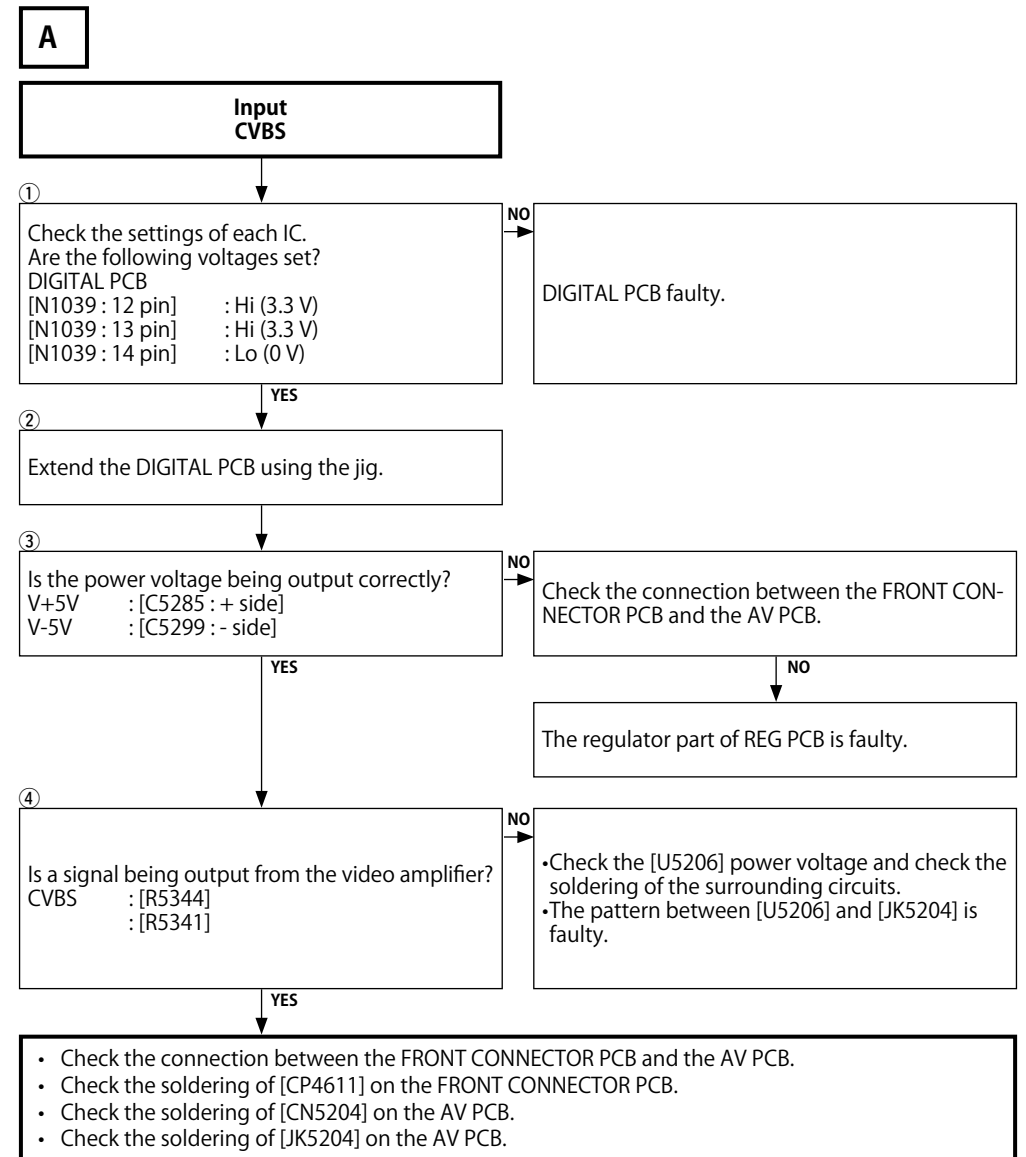
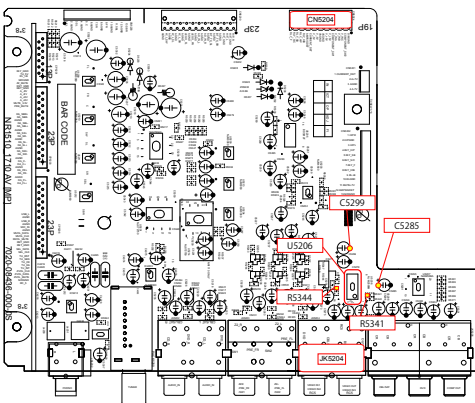

※ These instructions refer to the AV PCB unless otherwise specified.

### 3. HDMI/DVI

#### 3.1. No picture or sound is output (HDMI to HDMI)

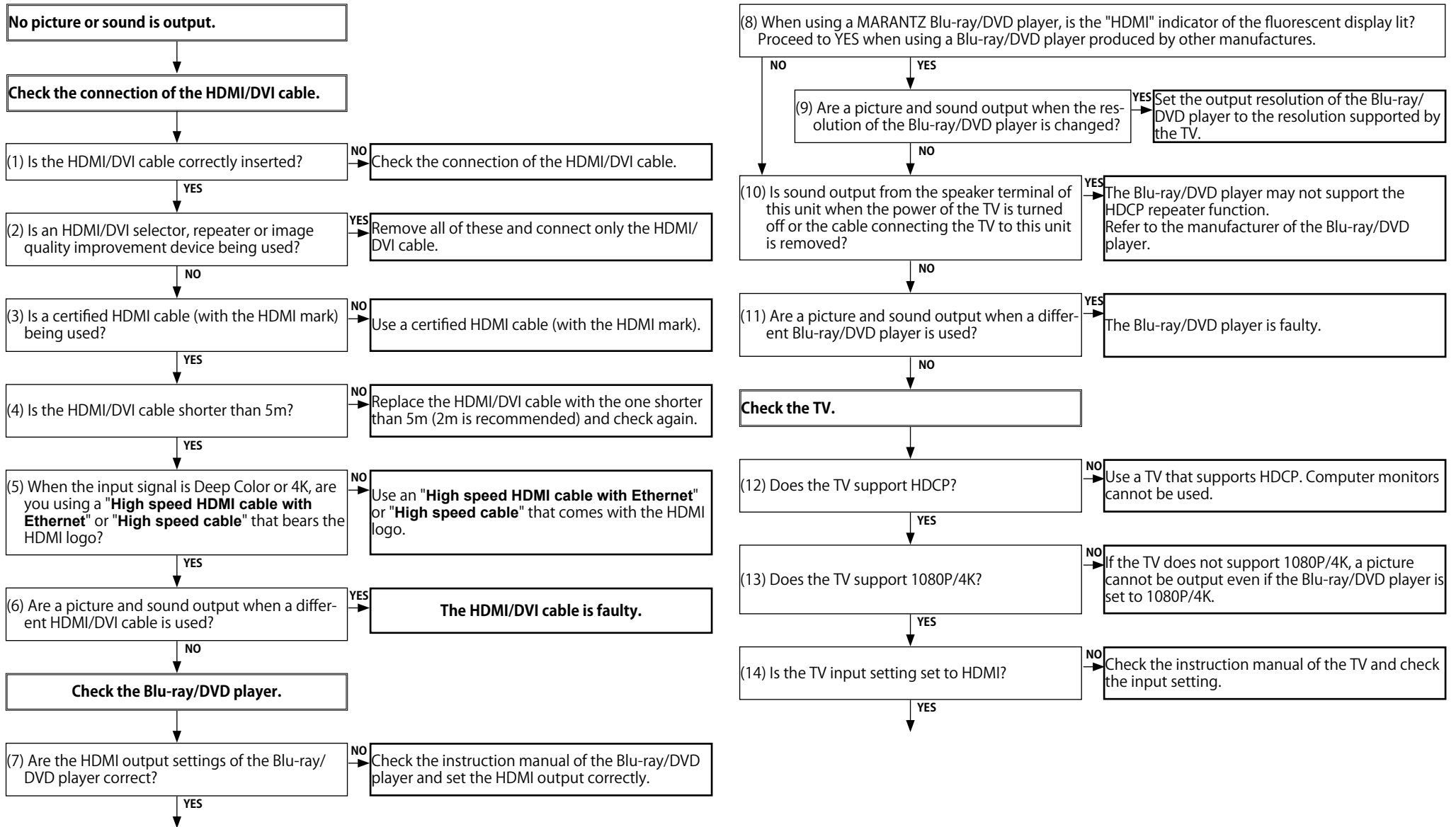

Go to next page.



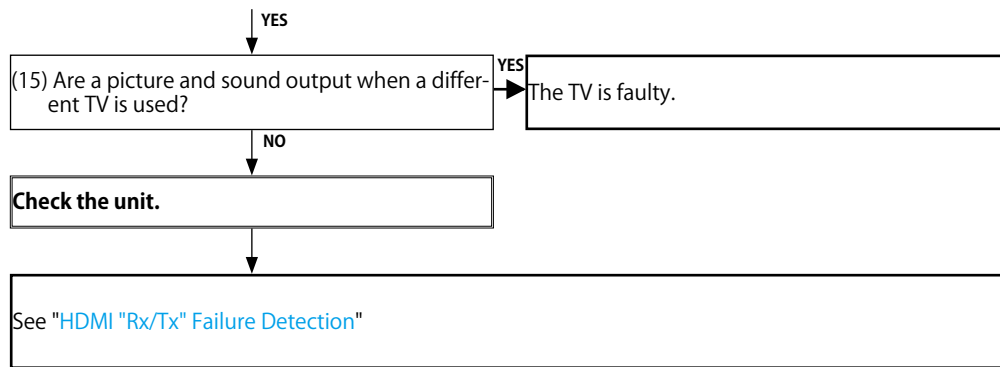

# 4. AUDIO

## 4.1. AUDIO CHECK

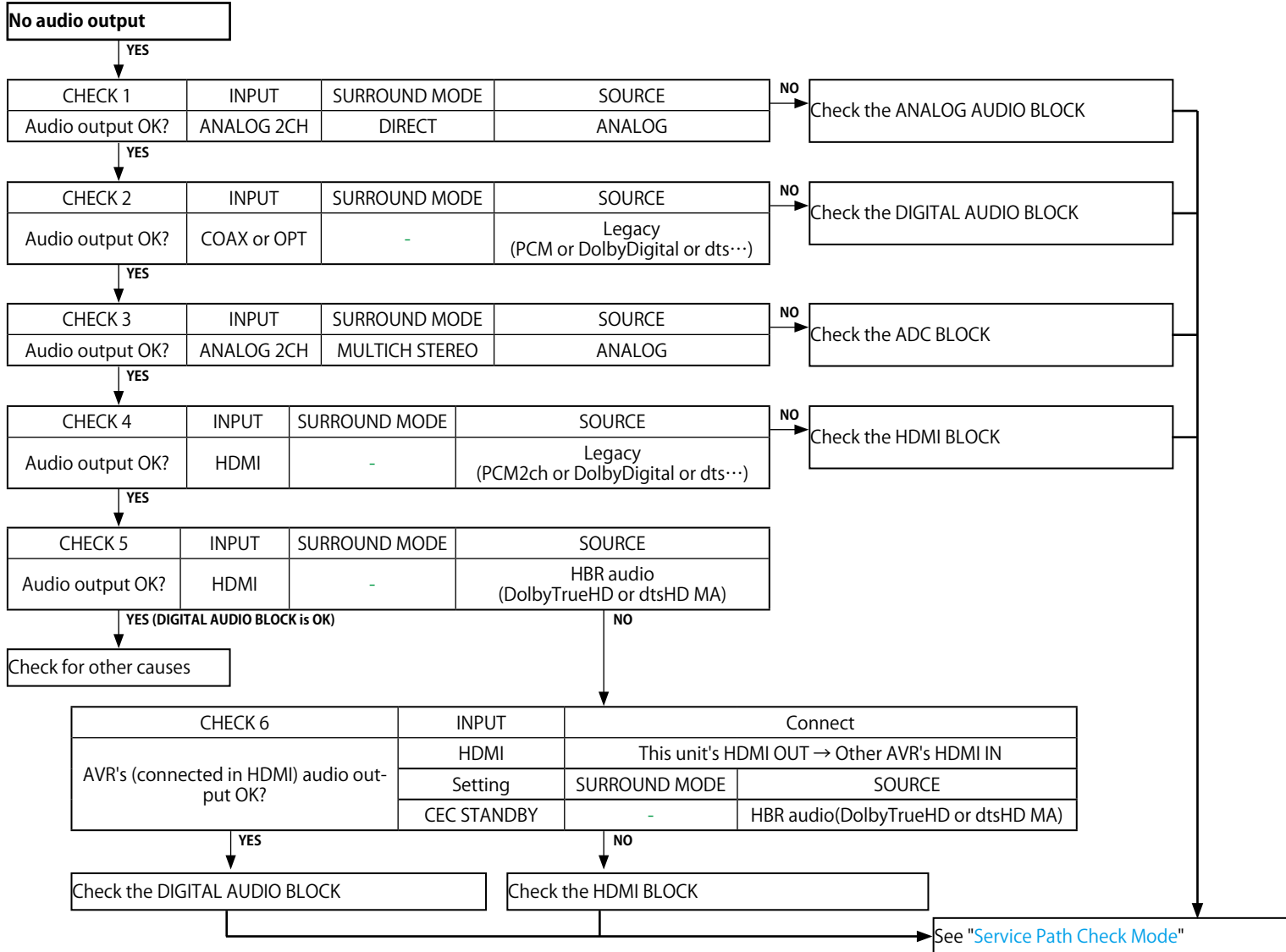

## 4.2. Power AMP (AMP PCB)

When using the protection pass mode, do not connect speakers to the speaker terminals.

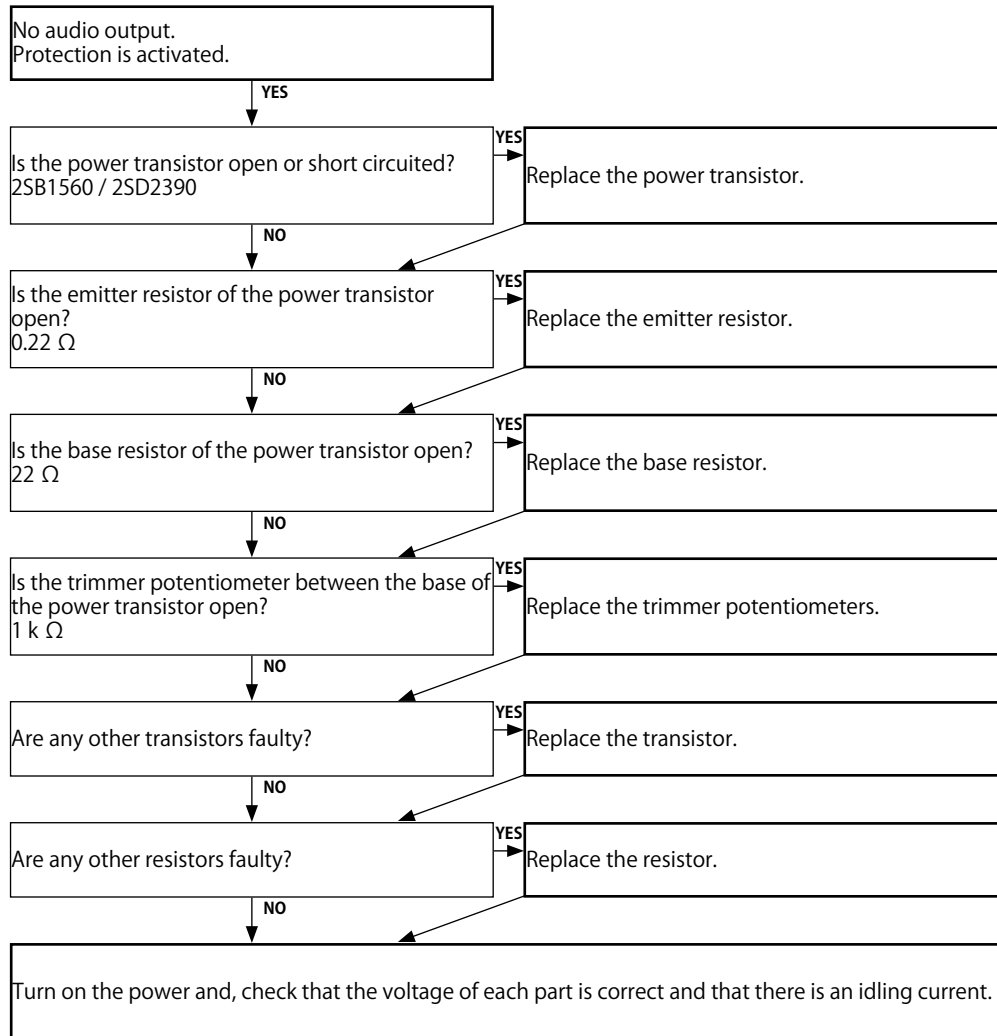

## 4.3. Analog audio

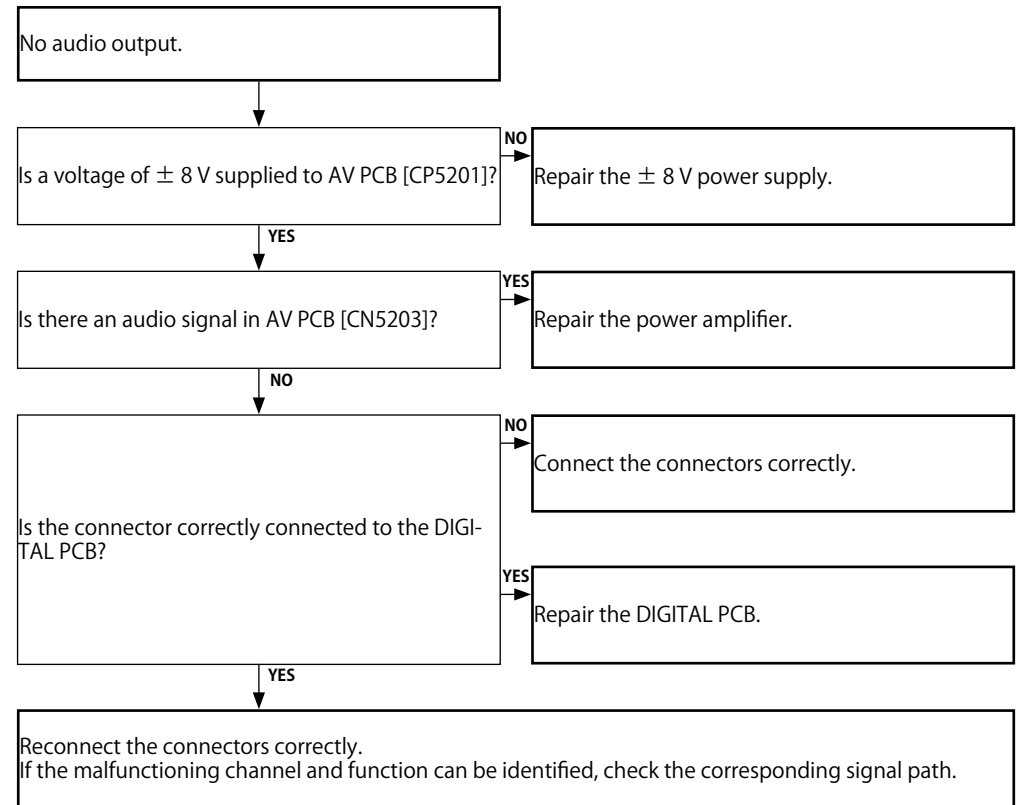

## 5. Network / Bluetooth / USB

### 5.1. Cannot connect to the network

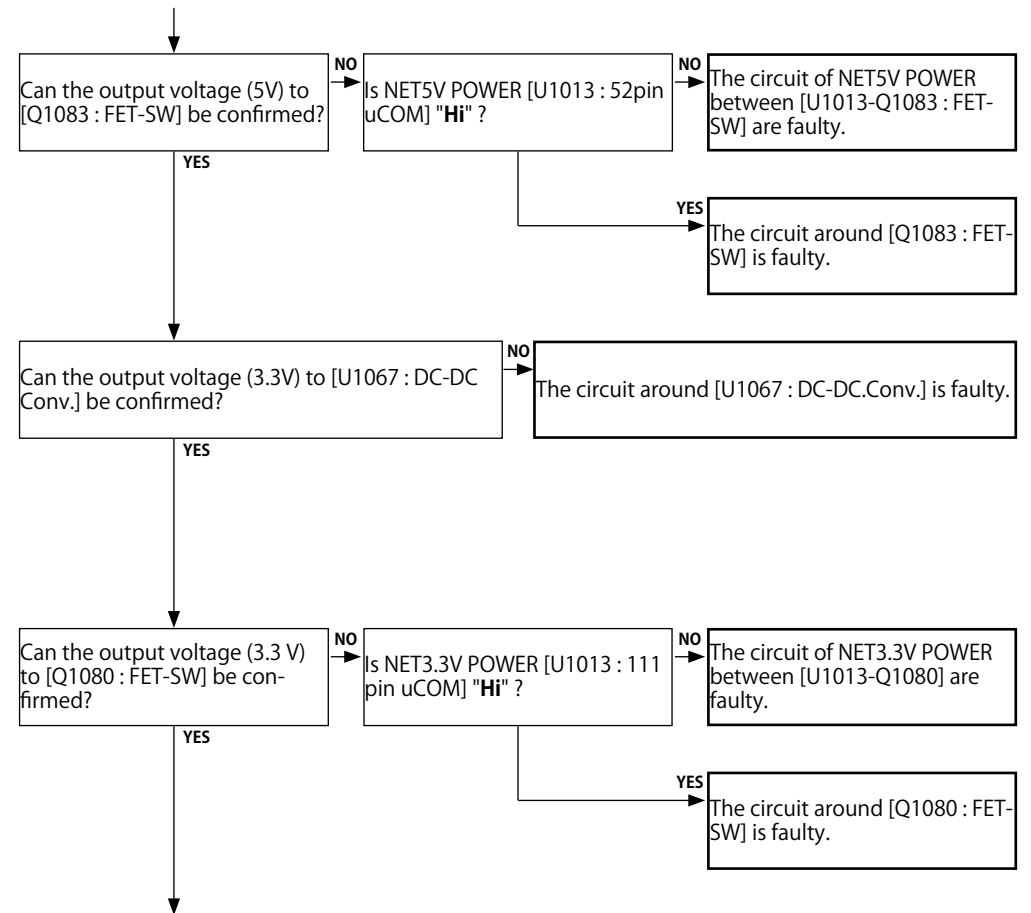
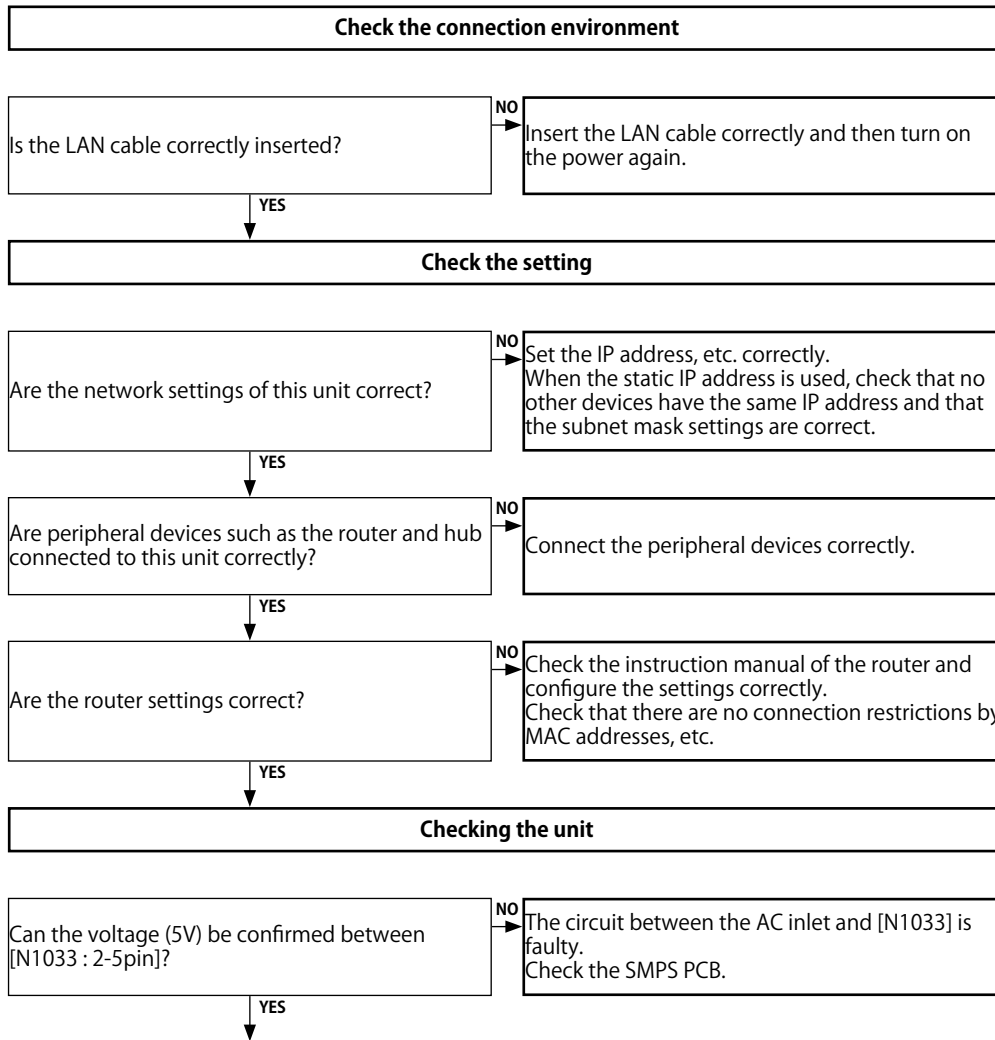

Go to next page.

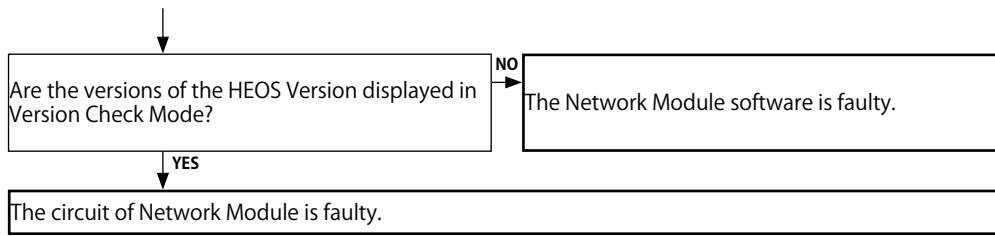

## 5.2. Cannot establish a Bluetooth connection

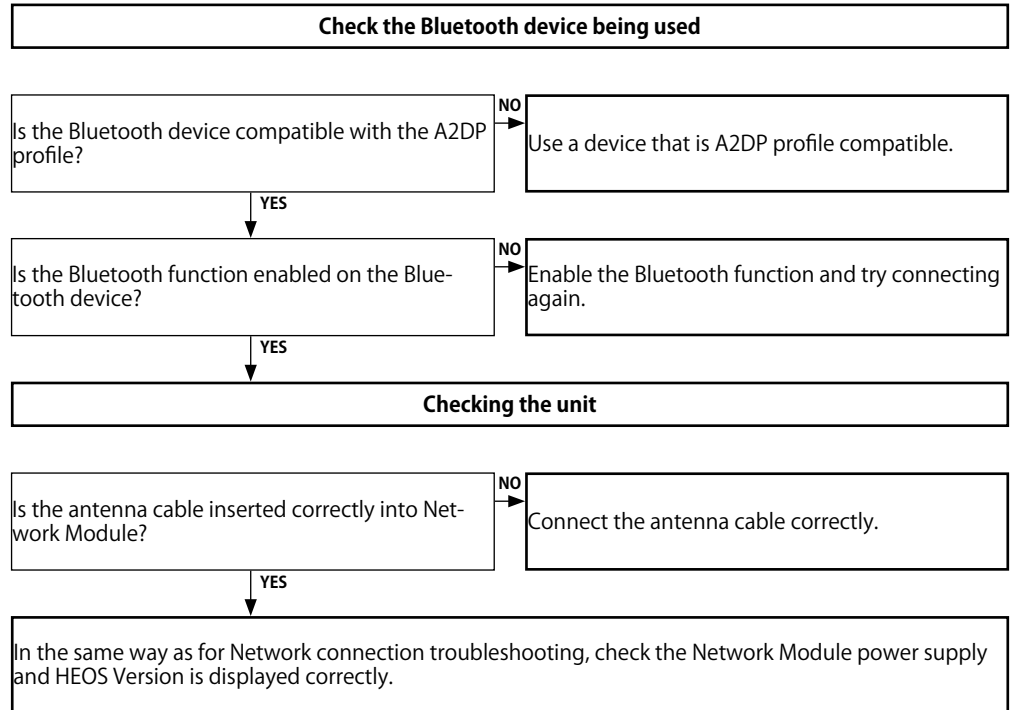

### 5.3. Cannot recognize the connected USB device

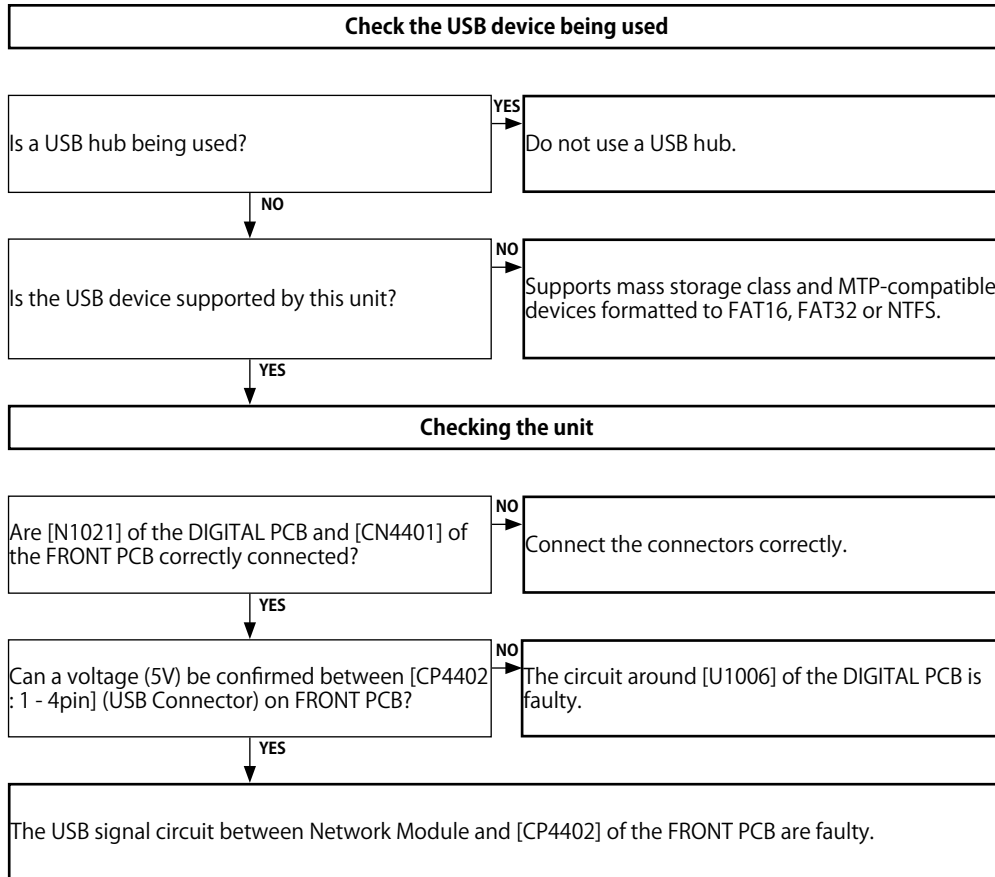

### 5.4. No picture or sound is output

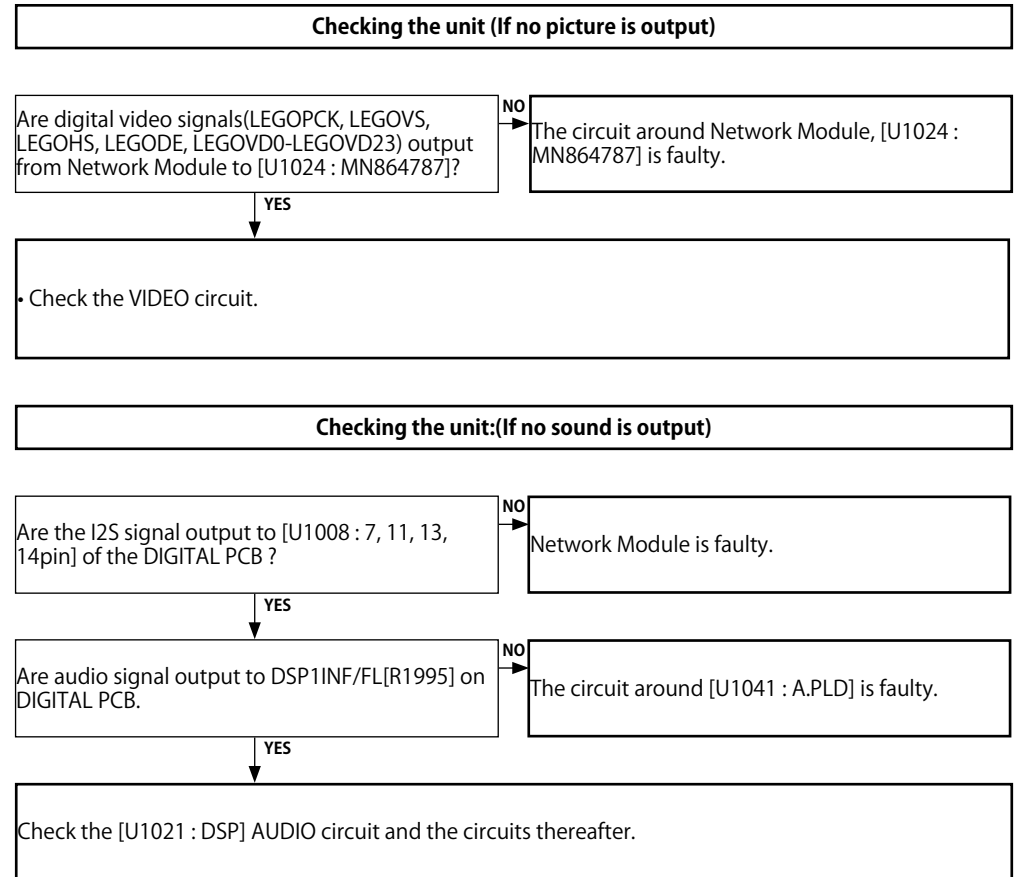

## DIGITAL test point

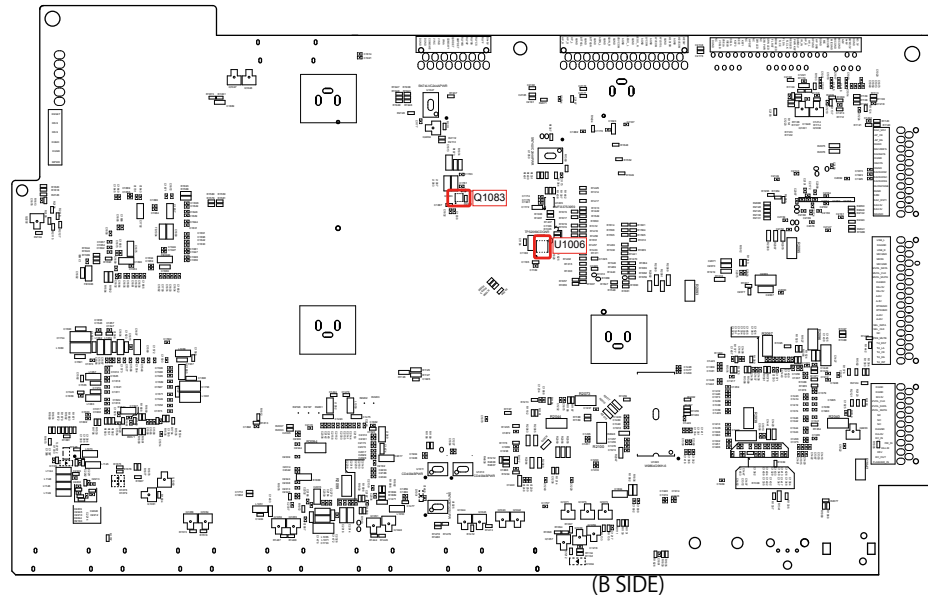
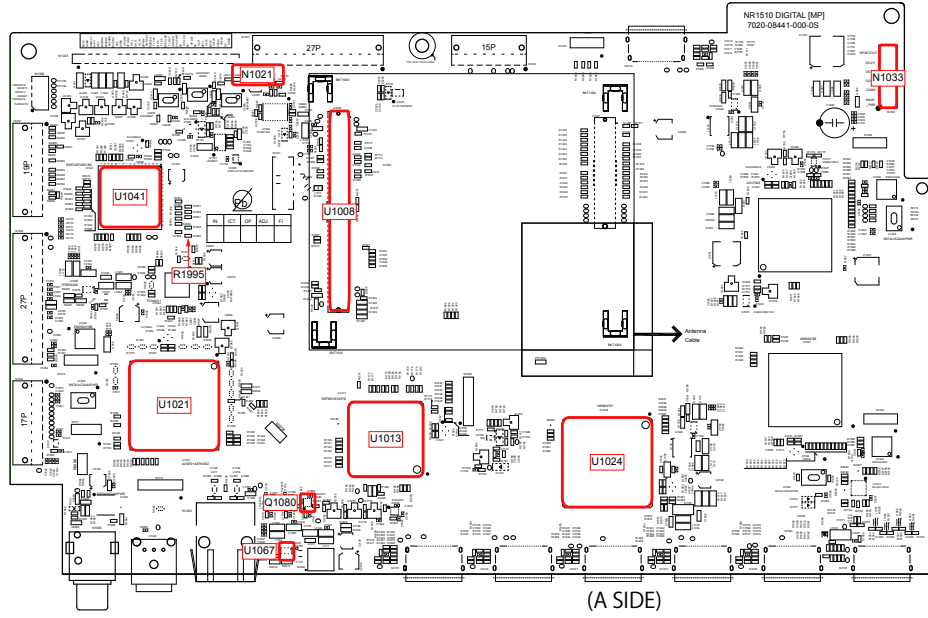

## USB test point

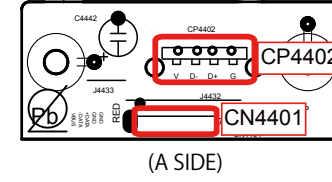

# 6. SMPS

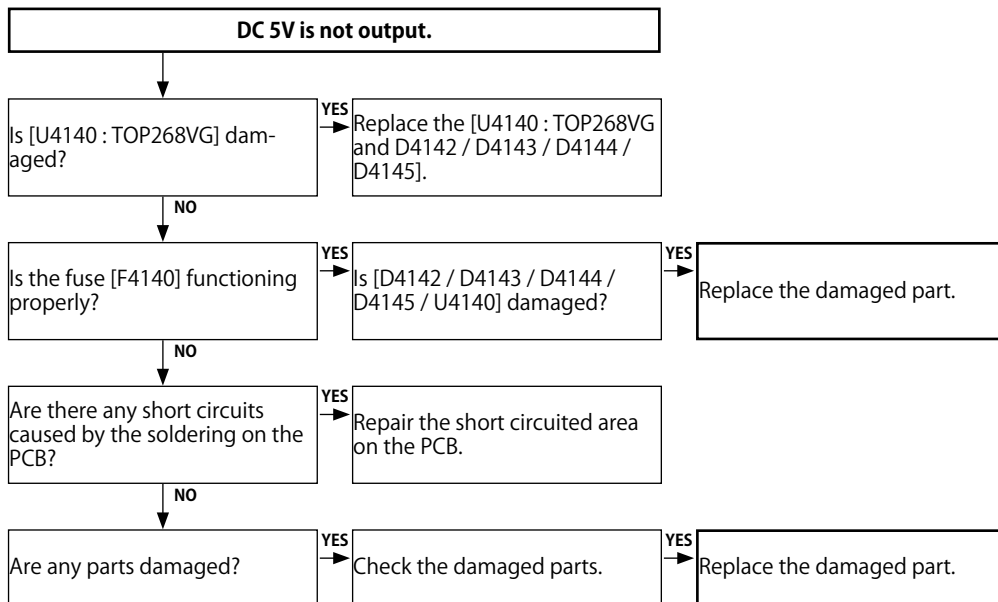

## Operation waveform for each part

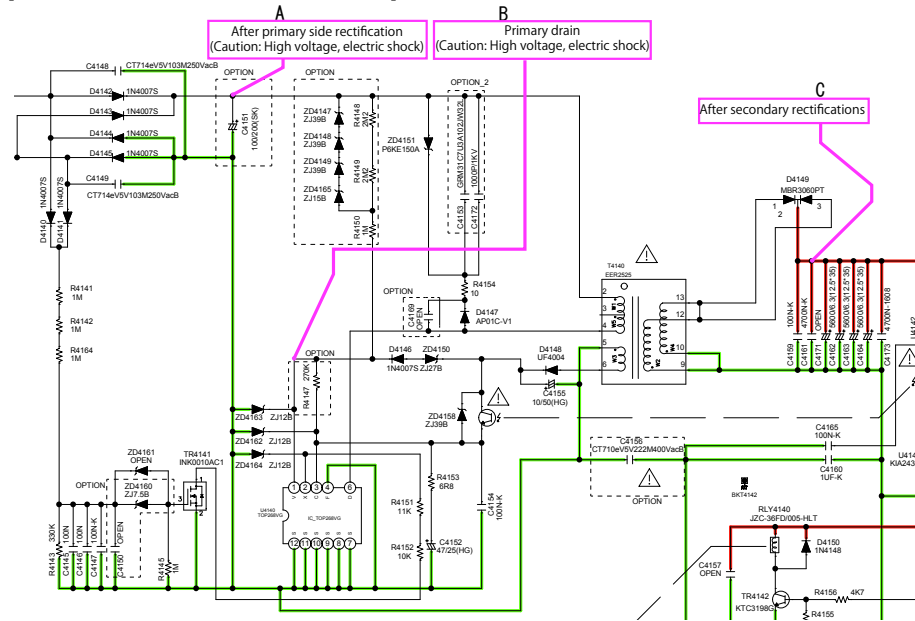

SMPS unit (Unloaded)

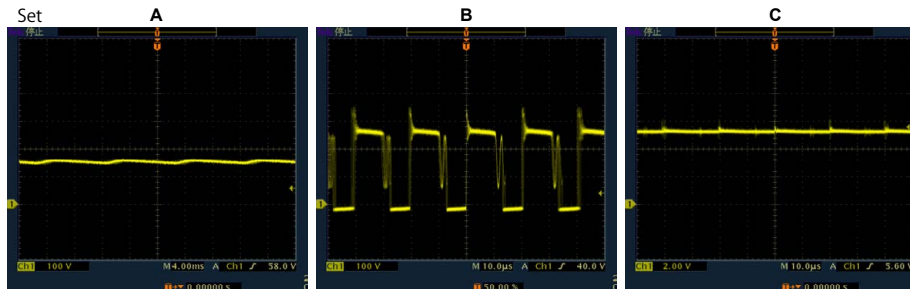
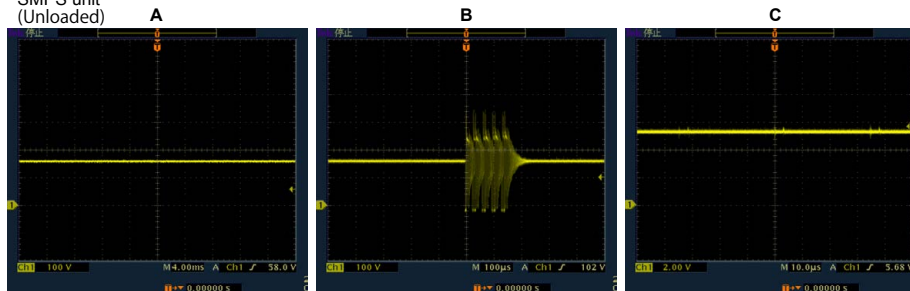

Before Servicing This Unit

Electrical

Mechanical

Repair Information

Updating



# HDMI "Rx/Tx" Failure Detection

## 1. Prior checking

Check item(1.): Checking the HDMI connector  
Checking the condition of the HDMI pin (rear/front).

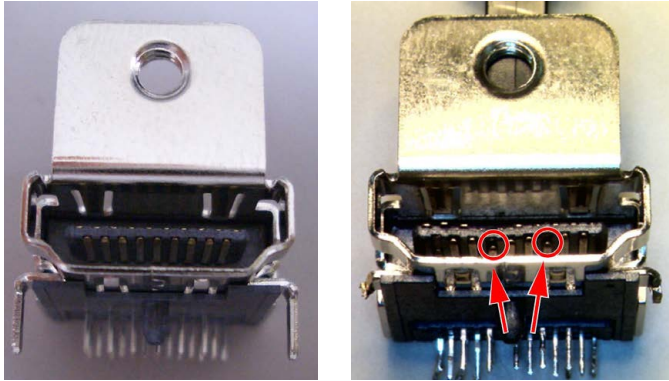

OK

NG

Check for deformed pins.

None of the pins are deformed.

There are deformed pins.

Replace the HDMI connector.

Check by following the flow chart for "3. Starting detecting the point of failure".

NOTE :

After checking troubleshooting "3. HDMI/DVI", check "3. Starting detecting the point of failure".

## 2. Preparations for checking HDMI Switcher reception/transmission register

### 2-1. Necessary devices

- 1) Check the product settings.
- 2-a) Player with an HDMI terminal
- 2-b) TV with an HDMI terminal (\* NOTE : Do not use a computer monitor.)
- 3) Windows PC
- 4) Serial communication software "Termite.exe"  
(Download the software from [http://www.comphphase.com/software\\_termite.htm](http://www.comphphase.com/software_termite.htm) and install it.)
- 5) HDMI cable
- 6) RS-232C Straight cable
- 7) 8U-210100S WRITING KIT
- 8) oscilloscope

### 2-2. Device Connection Method

Connect the TV and the AVR to the player using an HDMI cable and connect the AVR to the PC through an RS-232C cable as shown in Figure 1.

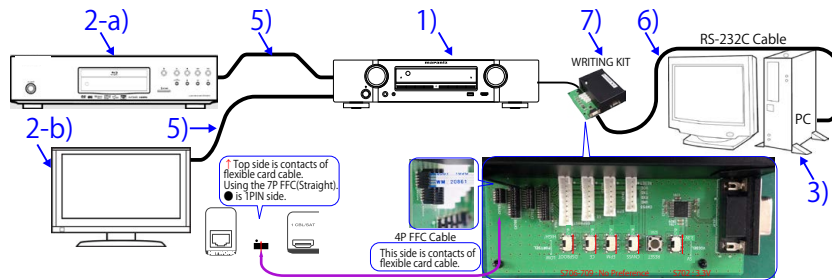

Figure 1 Device Connection Method (NR1510)

### 2-3. Device configuration method

PC settings : Execute the serial communication program, Termite.exe.

After executing Termite.exe, click [Settings].

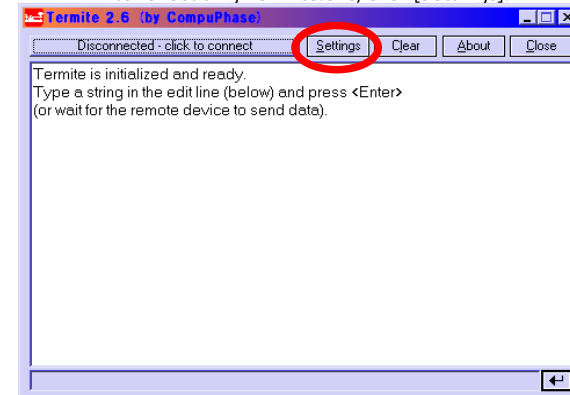

Figure 2. Screen After Executing Termite.exe

The serial port setup screen will be displayed.

Configure the settings as shown in Figure 3 and click the "OK" button.

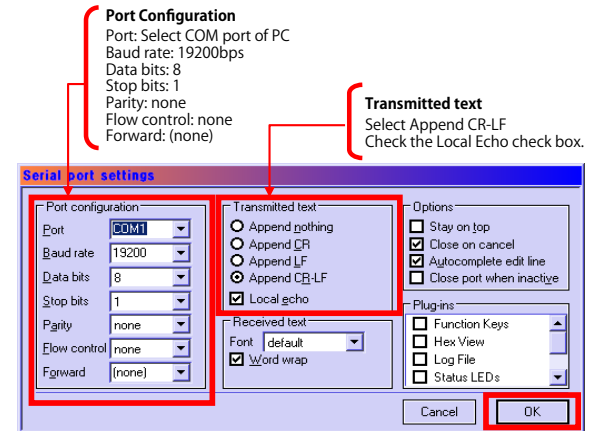

Figure 3. Serial Port Setup Screen

Click the [click to connect] button to start communication.  
 After a connection is established successfully, the display of the button name will change as shown in Figure 4.

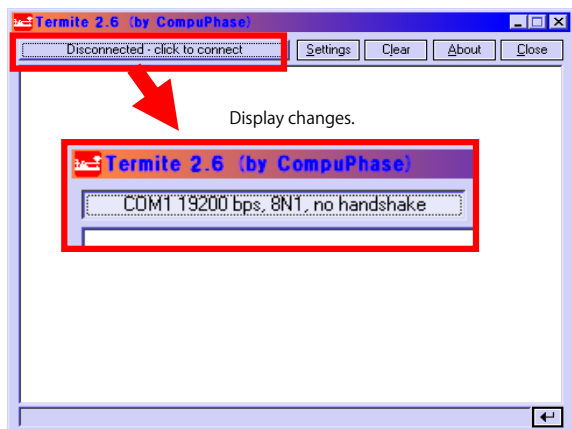

Figure 4. Change of the Display of the Communication Start Button Name

TV settings : Switch to the HDMI input in the AVR connection.  
 Player settings : Turn the unit power on and configure it to play disks.  
 AVR settings : While the power is On, hold down buttons "M-DAX" and "PRESET CH +" for at least 3 seconds.  
 (Continue to press and hold the buttons until all segments of the FLD volume illuminate.)  
 ※ When the power is turned on after initialization, "Setup Assistant" will be displayed.  
 After exiting "Setup Assistant" execute the above.

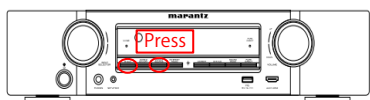

Figure 6-1. AVR settings (NR1510)

for Volume 7 segment  
 All the indicator Lights

 A close-up of a red digital display showing the number '-00.8'. An arrow points from the text 'All the indicator Lights' to the display.

Figure 6 FLD Display When Set

When the settings are correct, the following message will be displayed in the window of Termite.  
 [00]Start Sub CPU Log Mode  
 \*\*\*\*  
 (\*\*\*\* is a version of Sub CPU.)

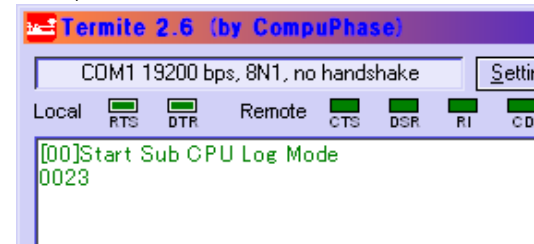

Figure 7. Display of Termite When AVR is Set

The setup is now complete.

Method for sending commands

Enter the command in the transmission command entry section, click the [Send] button and send the command.

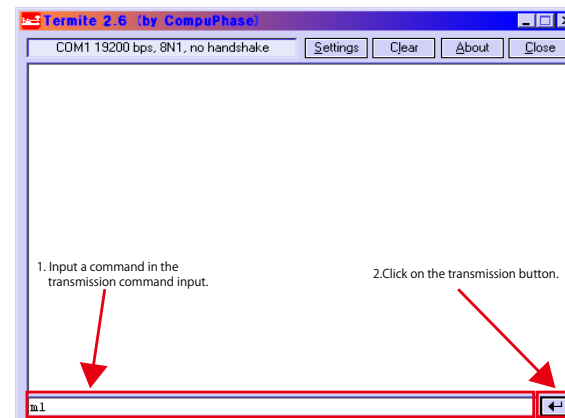

Figure 8. Method for Sending Termite Commands

### 3. Starting detecting the point of failure

#### Check item(3.1).

Check the power supply status and communication status with the CPU of each device.  
Start in HDMI Diagnostics mode and follow the procedures below.

#### Start in HDMI Diagnostics mode

While the power is on, hold down buttons "M-DAX" and "DIMMER" for at least 3 seconds.

HDMI DIAGNOSTICS

↓ "HDMI DIAGNOSTICS" is displayed.

When the mode has switched, start Hardware Check.

HardwareCheck...



#### Display when an Error is detected.

Err: H1-XX

↓↑ Alternating display.

Contact support

Check the Error Code table items.

#### Error Code table

Error Code	Check item No.	Description
H1-01	<a href="#">Check item (3-1.1.)</a>	Communication Error with HDMI RX/Tx [U1027 : MN864788]
H1-02	<a href="#">Check item (3-2.1.)</a>	Communication Error with HDMI SW [U1024 : MN864787]
H1-07	<a href="#">Check item (3-3.1.)</a>	Communication Error with OSD [U1030 : ADV7623]
H1-08	<a href="#">Check item (3-5.1.)</a>	Communication Error with DSP [U1021 : ADSP21487]
H1-12	<a href="#">Check item (3-6.1.)</a>	Communication Error with DIR [U1040 : PCM9211]
H1-15	<a href="#">Check item (3-4.1.)</a>	Communication Error with OSD ROM [U1029 : MX25L3206EMI/MX25L6406EMI]
H1-16	<a href="#">Check item (3-8.1.)</a>	Communication Error with ARC IC [U1012 : SiI9437]

#### Display when an Error is not detected.

1 Auto Test

Cancel the mode, and proceed to [check item \(3.2.\)](#).

Canceling the selected mode

Press the power button to exit off the power.

**Check item(3.2).** : Check operation of the HDMI input terminal.



When the HDMI input terminal of this device is connected to the player correctly, is sound heard from the speaker?  
 ※ When checking, turn the AV amplifier on and off after checking the connection terminal with the player. (To set the same conditions during verification of operation)

Check that sound is heard from the input terminal of the HDMI 4, 5.  
 Use any of Dolby TrueHD/DTSHD MA/PCM 8ch for the playback audio format.

**NO**  
 Is the "DIG" indicator illuminated on the FLD?  
 When the "DIG" indicator is illuminated, the digital audio block is faulty.  
 If the "DIG" indicator is not illuminated, go to **check item (3-8.1.)**.  
 (HDMI Rx/Tx IC [MN864788] failure detection procedure)

Check that sound is heard from the input terminal of the HDMI 1 - 3.

**NO**  
 Go to **check item (3-9.1.)**.  
 (HDMI SW [MN864787] failure detection procedure)

Check that sound is heard from the input terminal of the FRONT AUX.

**NO**  
 Go to **check item (3-10.1.)**.  
 (HDMI DDC Buffer IC [TCA9517] failure detection procedure)

**YES**

**Check item(3.3).** : Check operation of the HDMI output terminal.

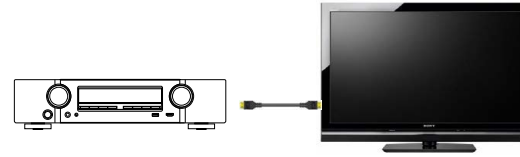

When the "SETUP" button on a remote control is pressed, is "MENU" displayed on TV which is connected to the HDMI output terminal on the AVR?

**NO**  
 Go to **check item (3-11.1.)**.  
 (OSD [ADV7623] failure detection procedure)

**Check item(3.4).** : Check operation of the HDMI output terminal.

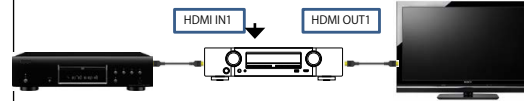

When the player is connected to the HDMI input terminals in order, are the images on the player displayed on the TV in both cases?

**NO**  
 Go to **check item (3-12.1.)**.  
 (Between HDMI Tx [MN864788] & OSD [ADV7623] failure detection procedure)

**YES**  
 There is no problem with Rx, Tx, and GUI of HDMI as well as IC of SW.

### 3-1. Error Code H1-01 failure detection procedure

Checking device. (HDMI Rx/Tx)

Check the power supply voltage. (HDMI Rx/Tx)

**Check item(3-1.1).** Check the power supply voltage. :  
Does the power supply voltage of the HDMI Rx/Tx [U1027] indicate the correct voltage (1.1V, 3.3V)?  
The test points are as follows.

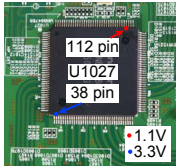

YES

NO

**Check item(3-1.2).** Check the power supply voltage. :  
Check the power components [U1064/U1067/Q1079] and the pattern on the substrate.  
If there is no problem, remove the HDMI Rx/Tx [U1027] from the substrate and measure the voltage at the test point of **check item (3-1.1)**.  
Is the voltage correct (1.1V or 3.3V)?

YES

NO

Replace with a new device.

The power supply circuit is faulty.  
Replace the PCB.

Recheck from **check item (3.1)**.  
If it does not work, replace the PCB.

Checking the reset waveform. (HDMI Rx/Tx)

**Check item(3-1.3).** Checking the reset waveform :  
Check the waveform.  
When the power is turned on, is the TP waveform correct (as shown in the figure)?

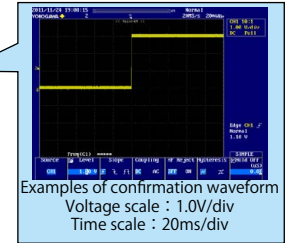
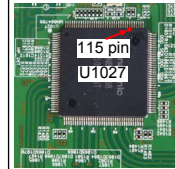

NO

Check the reset circuit between CPU [U1013] and HDMI Rx/Tx [U1027].  
If there is no problem, the HDMI Rx/Tx [U1027] is faulty.  
Replace with a new device.  
Recheck from **check item (3.1)**.  
If it does not work, replace the PCB.

YES

Go to next page.

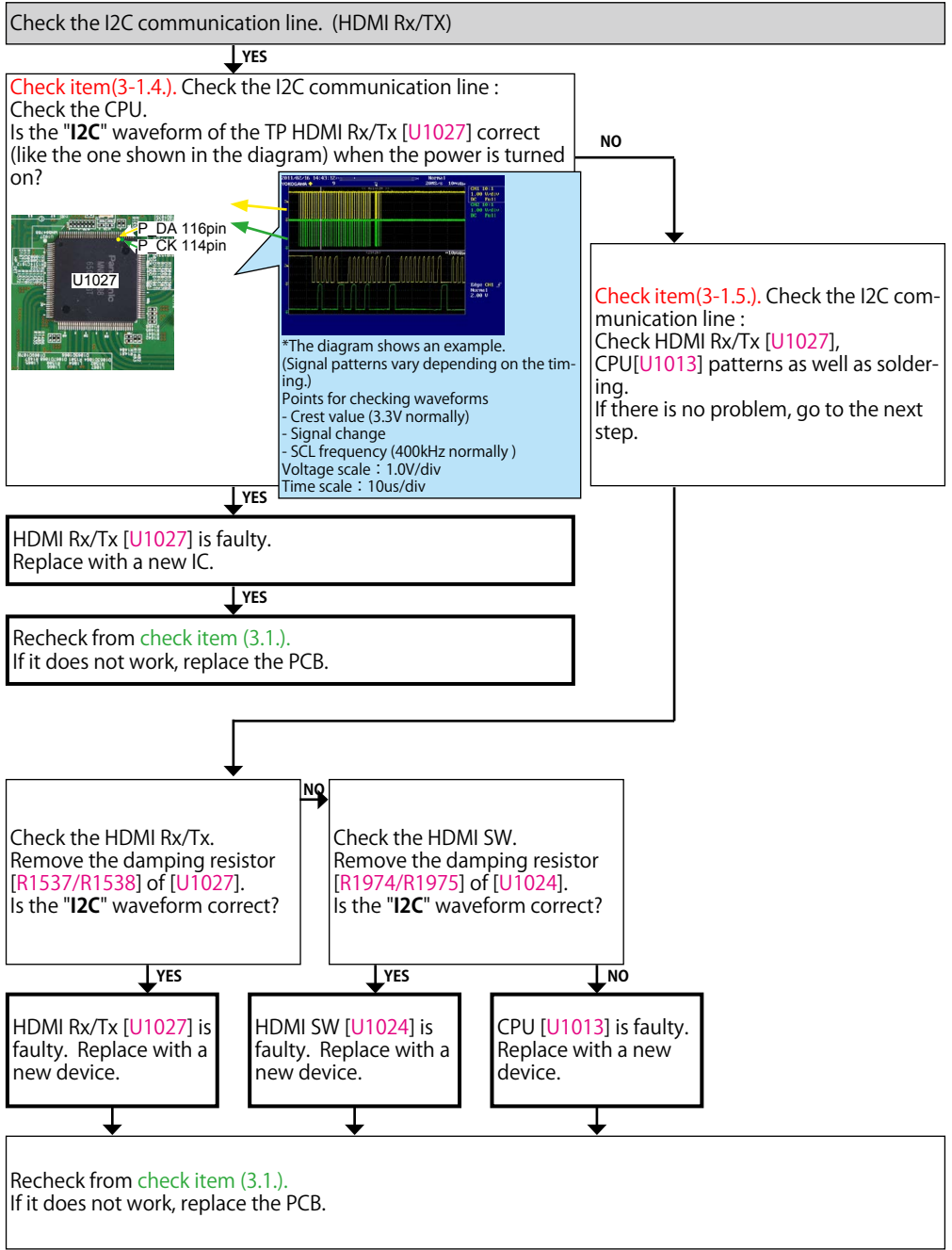

## 3-2. Error Code H1-02 failure detection procedure

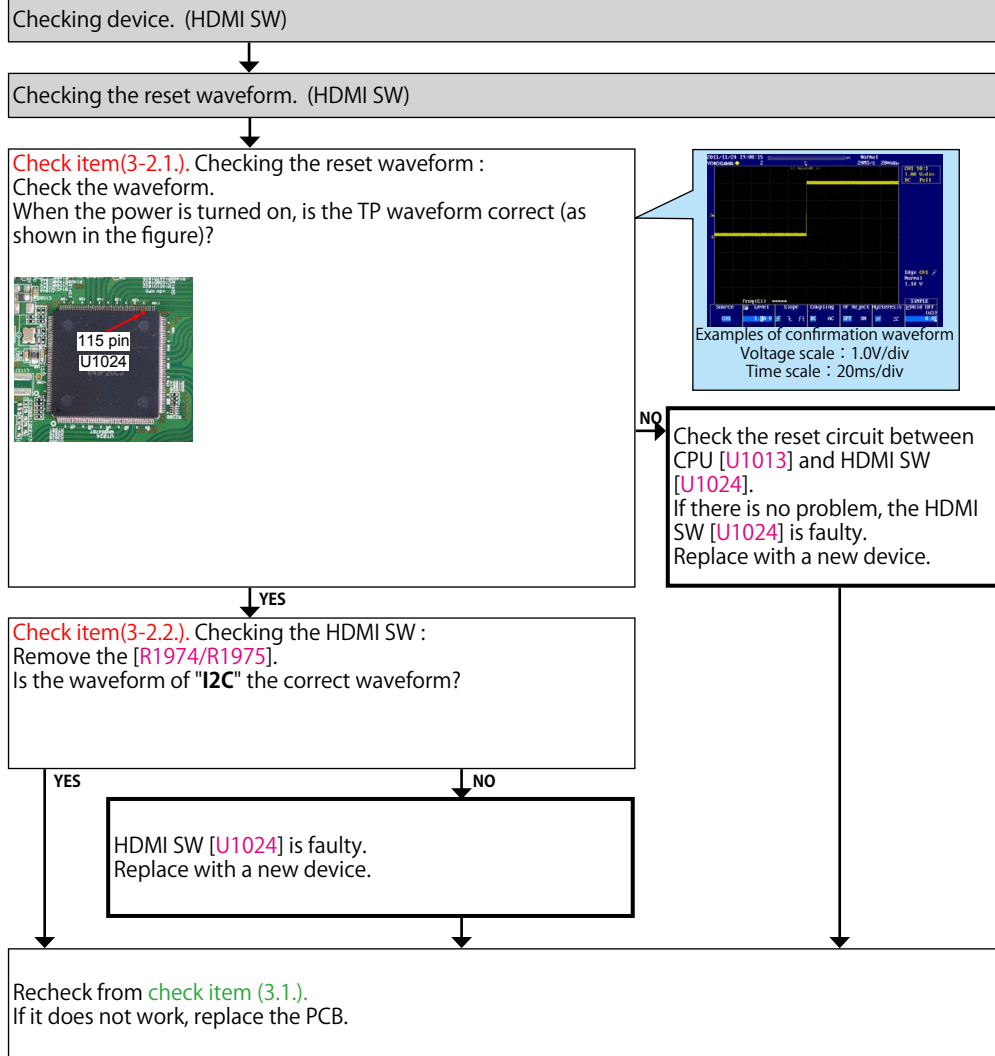



### 3-3. Error Code H1-07 failure detection procedure

Checking device. (OSD)

Check the power supply voltage.

**Check item(3-3.1).** Check the power supply voltage.:  
Does the power supply voltage of the OSD [U1030] indicate the appropriate voltage (1.8V, 3.3V)?  
The test points are as follows.

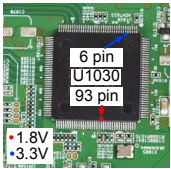

**Check item(3-3.2).** Check the power supply voltage.:  
Check the power supply components [U1067/Q1077/U1069] on the substrate and peripheral pattern.  
If there is no problem, remove the OSD [U1030] from the substrate and measure the voltage at the test point of **check item (3-3.1)**.  
Is the voltage correct (1.8V or 3.3V)?

YES

YES

The power supply circuit is faulty.  
Replace the PCB.

NO

HDMI OSD [U1030] is faulty.  
Replace with a new device.

Recheck from **check item (3.1)**.  
If it does not work, replace the PCB.

Checking the reset waveform.

**Check item(3-3.3).** Checking the reset :  
Check the CPU.  
When the power is turned on, is the TP waveform correct (as shown in the figure)?

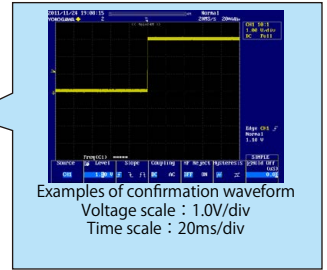
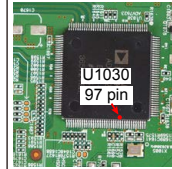

YES

NO

Check the reset circuit between CPU [U1013] and HDMI OSD[U1030].  
If there is no problem, the HDMI OSD [U1030] is faulty.  
Replace with a new device.

Recheck from **check item (3.1)**.  
If it does not work, replace the PCB.

Go to next page.

Check the I2C communication line.

↓ YES

**Check item(3-3.4).** Check the I2C communication line :  
Check the CPU.  
Is the "I2C" waveform of the HDMI OSD [U1030] correct (like the one shown in the diagram) when the power is turned on?

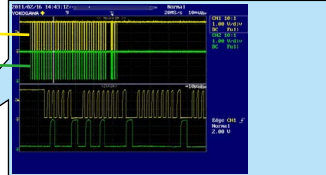
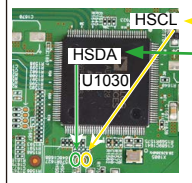

\*The diagram shows an example.  
(Signal patterns vary depending on the timing.)  
Points for checking waveforms  
- Crest value (3.3V normally)  
- Signal change  
- SCL frequency (400kHz normally)  
Voltage scale : 1.0V/div  
Time scale : 10us/div

YES      NO

**Check item(3-3.5).** Check the I2C communication line :  
Check HDMI OSD [U1030], CPU [U1013] patterns as well as soldering.  
If there is no problem, go to the next step.

Remove the damping resistor [R1622/R1606] of [U1030].  
Is the "I2C" waveform correct?

NO  
CPU [U1013] is faulty.  
Replace with a new device.

YES  
OSD [U1030] is faulty.  
Replace with a new device.

Recheck from **check item (3.1.)**.  
If it does not work, replace the PCB.

### 3-4. Error Code H1-15 failure detection procedure

Checking device. [U1029 : MX25L3206EMI(U, K, F)/MX25L6406EMI(N)]

**Check item(3-4.1).**  
Write to the OSD ROM.  
Recheck from **check item (3.1).**  
Does Error Code H1-15 continue?

NO

YES

**Check item(3-4.2).**  
Replace [U1029] with a new device.  
Recheck from **check item (3.1).**  
Does Error Code H1-15 continue?

NO

YES

Go to **check item (3-3.1).**

Recheck from **check item (3.2).**

### 3-5. Error Code H1-08 failure detection procedure

Checking device. [U1021 : ADSP21487]

Check the power supply voltage.

**Check item(3-5.1).** Check the power supply voltage.:  
Does the power supply voltage of the DSP [U1021] indicate the appropriate voltage (1.0V, 3.3V)?  
The test points are as follows.

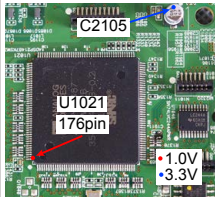

**Check item(3-5.2).** Check the power supply voltage.:  
Check the power supply components [U1067/Q1077/U1068] on the substrate and peripheral pattern.  
If there is no problem, remove the DSP [U1021] from the substrate and measure the voltage at the test point of **check item (3-5.1)**.  
Is the voltage correct (1.0V or 3.3V)?

YES

YES

NO

The power supply circuit is faulty.  
Replace the PCB.

DSP [U1021] is faulty.  
Replace with a new device.

Recheck from **check item (3.1)**.  
If it does not work, replace the PCB.

Checking the reset waveform.

**Check item(3-5.3).** Checking the reset :  
Check the CPU.  
When the power is turned on, is the TP waveform correct (as shown in the figure)?

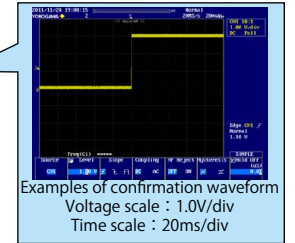
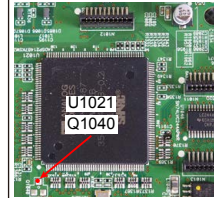

YES

NO

Check the reset circuit between CPU [U1013] and DSP [U1021].  
If there is no problem, the DSP [U1021] is faulty.  
Replace with a new device.

Recheck from **check item (3.1)**.  
If it does not work, replace the PCB.

Go to next page.

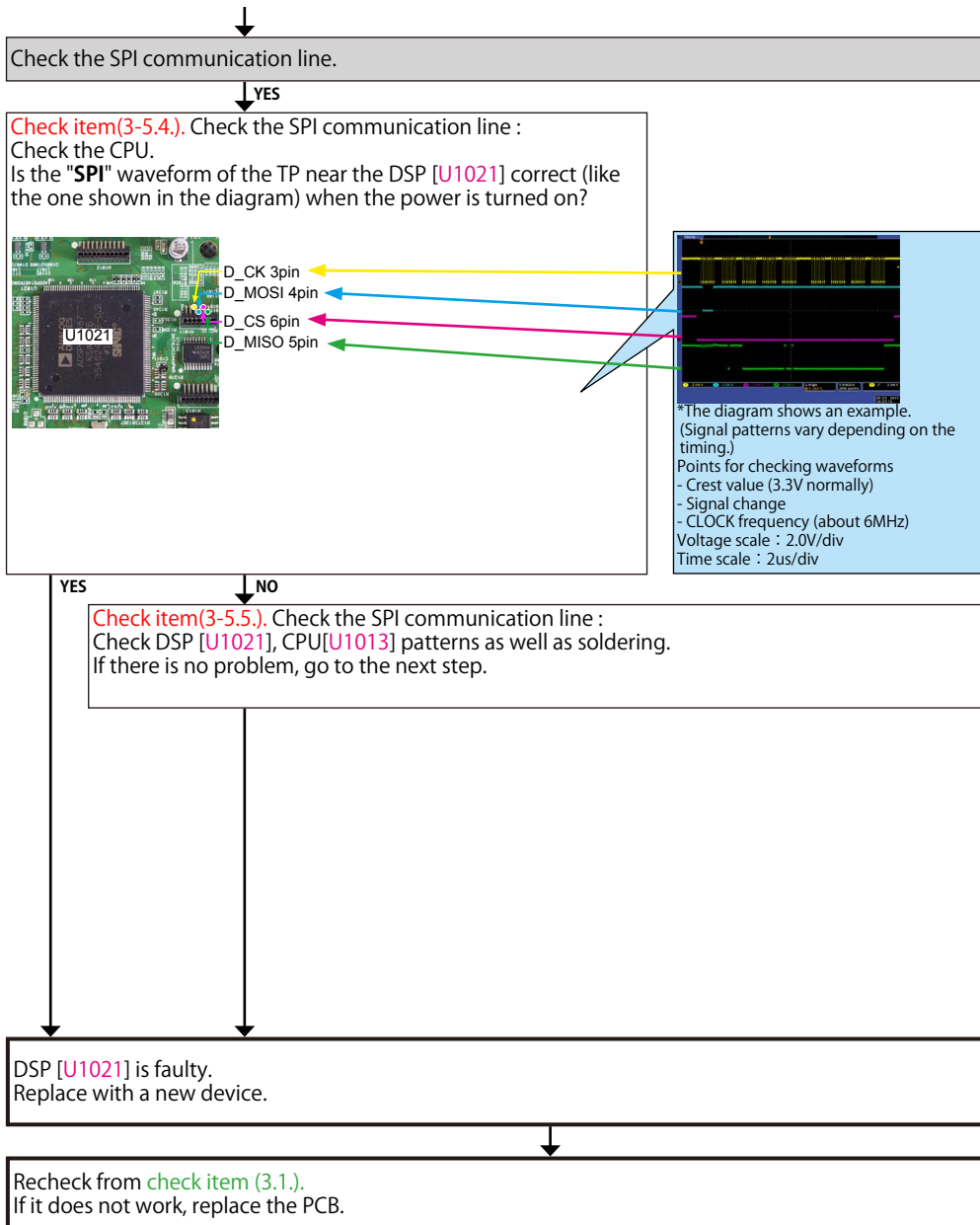

### 3-6. Error Code H1-12 failure detection procedure

Checking device. [U1040 : PCM9211]

Check the power supply voltage.

**Check item(3-6.1).** Check the power supply voltage.:  
Does the power supply voltage of the DIR [U1040] indicate the appropriate voltage (3.3V)?  
The test points are as follows.

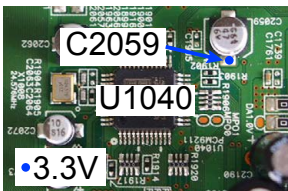

**Check item(3-6.2).** Check the power supply voltage.:  
Check the power supply components [U1067/ Q1077] on the substrate and peripheral pattern.  
If there is no problem, remove the DIR [U1040] from the substrate and measure the voltage at the test point of **check item (3-6.1)**.  
Is the power supply voltage correct (3.3V)?

Checking the reset waveform.

**Check item(3-6.3).** Checking the reset :  
Check the CPU.  
When the power is turned on, is the DIR [U1040 : 34pin] waveform correct (as shown in the figure)?

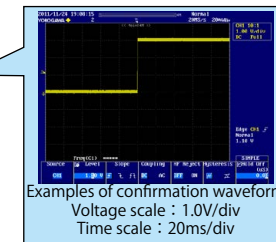
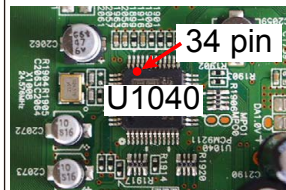

YES

YES

NO

YES

NO

The power supply circuit is faulty.  
Replace the PCB.

DIR [U1040] is faulty.  
Replace with a new device.

Recheck from **check item (3.1)**.  
If it does not work, replace the PCB.

Check the reset circuit between CPU [U1013] and DIR [U1040].  
If there is no problem, the DIR [U1040] is faulty.  
Replace with a new device.

Recheck from **check item (3.1)**.  
If it does not work, replace the PCB.

Go to next page.

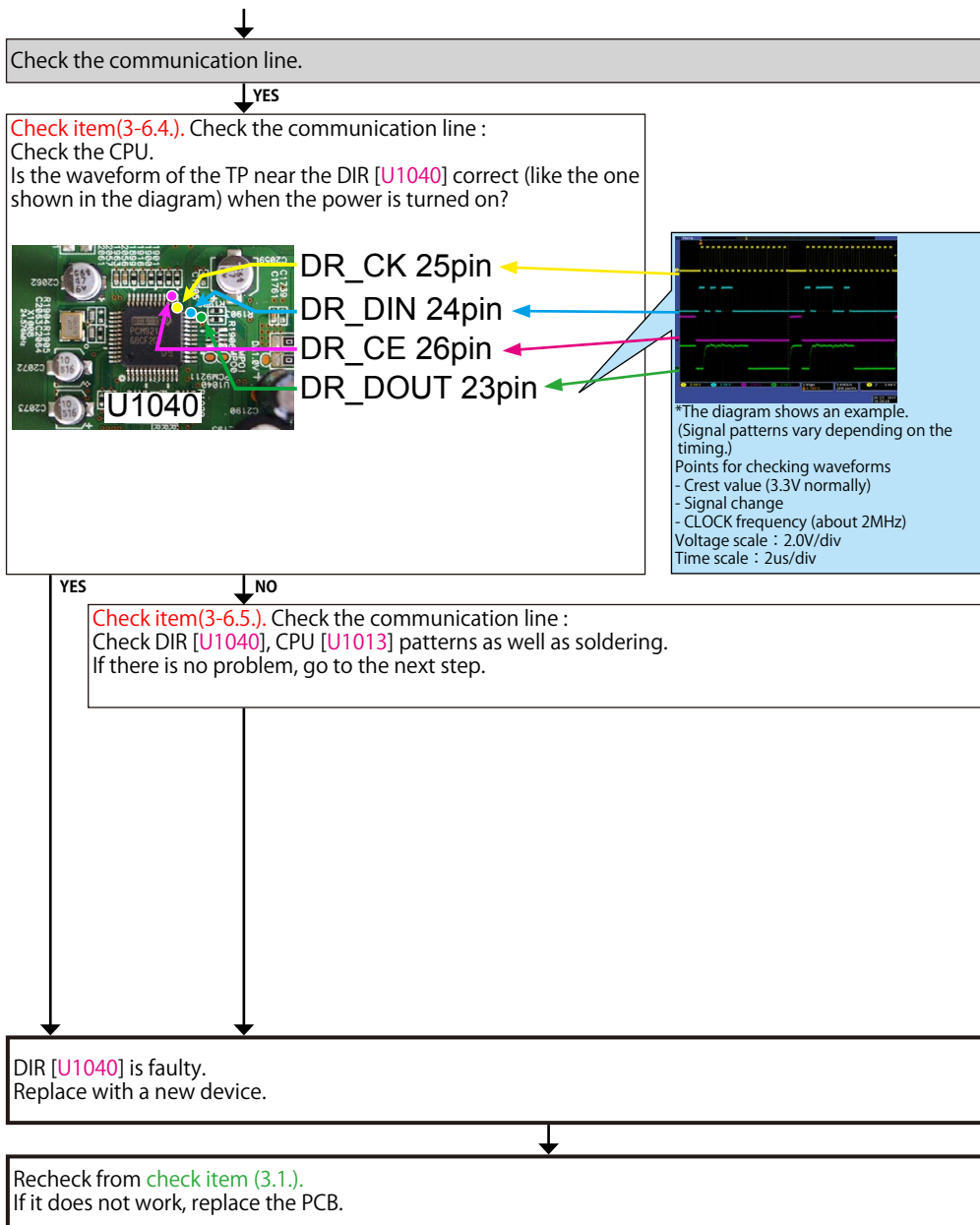

### 3-7. Error Code H1-16 failure detection procedure

Checking device. [U1012 : Sil9437]

Check the power supply voltage. (ARC IC)

**Check item(3-7.1).** Check the power supply voltage. :  
Does the power supply voltage of the ARC IC [U1012] indicate the correct voltage (1.2V)?  
The test points are as follows.

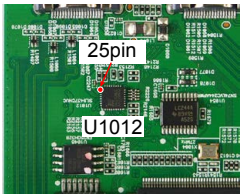

YES

NO

**Check item(3-7.2).** Check the power supply voltage. :  
Check the power components [U1033] and the pattern on the substrate.  
If there is no problem, remove the ARC IC [U1012] from the substrate and measure the voltage at the test point of **check item (3-7.1)**.  
Is the power supply voltage correct (1.2V)?

YES

NO

Replace with a new device.

The power supply circuit is faulty.  
Replace the PCB.

Recheck from **check item (3.1)**.  
If it does not work, replace the PCB.

Checking the reset waveform. (ARC IC)

**Check item(3-7.3).** Checking the reset waveform :  
Check the waveform.  
Is the "RESET" waveform of the ARC IC [U1012] correct (like the one shown in the diagram) when the power is turned on?  
The test points are follows.

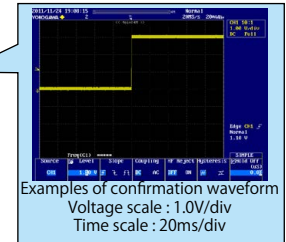
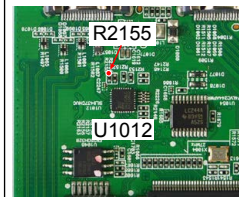

NO

Check the reset circuit between CPU [U1013] and ARC IC [U1012].  
If there is no problem, the ARC IC [U1012] is faulty.  
Replace with a new device.  
Recheck from **check item (3.1)**.  
If it does not work, replace the PCB.

YES

Go to next page.



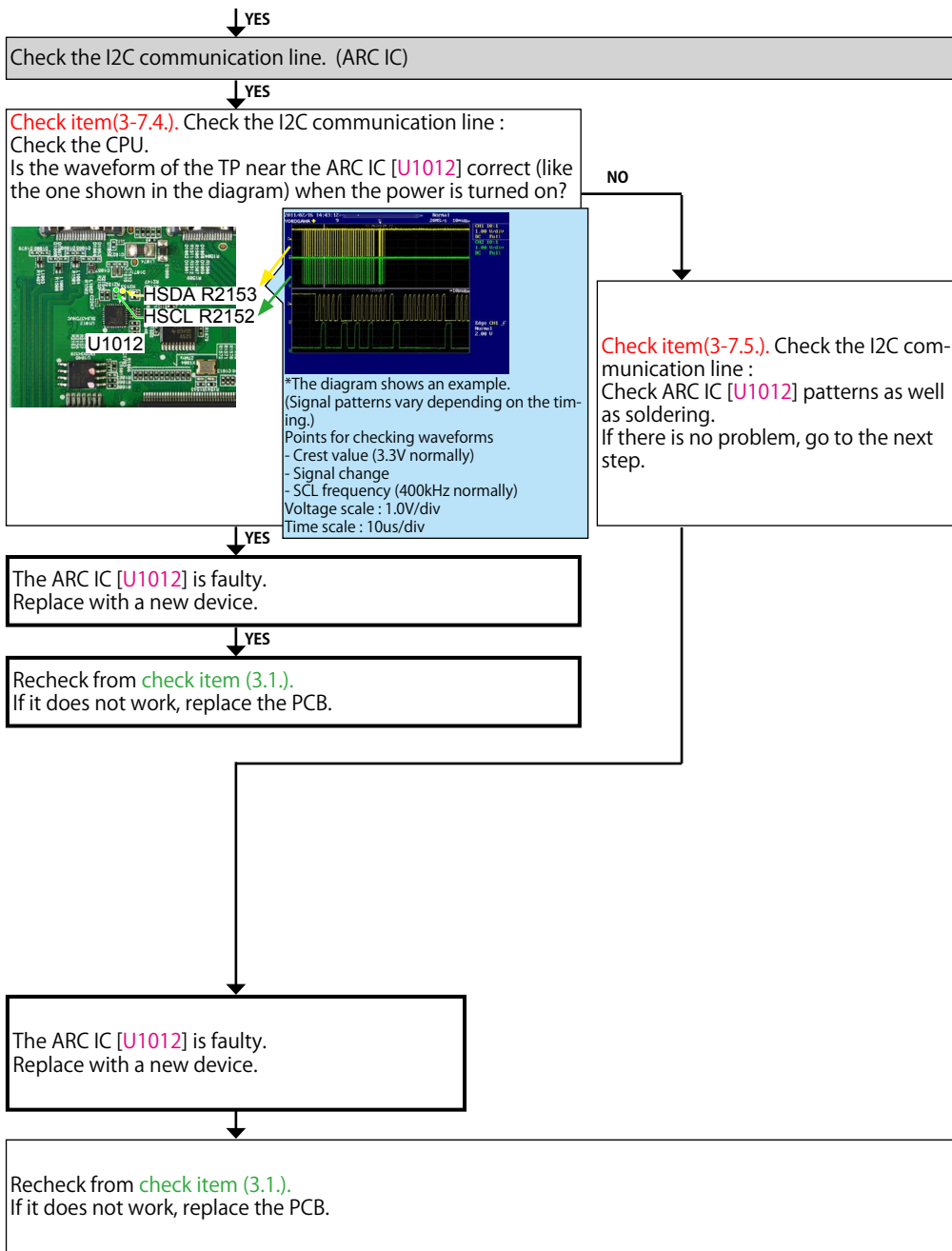

### 3-8. HDMI Rx [MN864788] failure detection procedure

Checking operation between the HDMI Rx/Tx device and the player



※ In order to check, connect the player to the HDMI terminal and configure the player as AVR source. Check the sound output while turning on the player.

Checking the +5V/DDC status register (HDMI Rx/Tx)

**Check item(3-8.1).** Checking the 5V status register :  
Send the following command from Termite.exe.  
Send the command "i 0006 00FF 0001".  
Move to the branch destination according to the value returned.

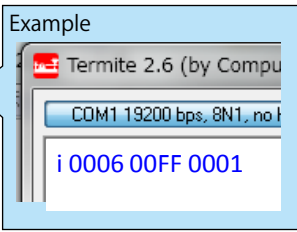

HDMI IN 4/5 "00"  
(Detection of 5V is not OK.)

Go to **check item (3-8.3).**

HDMI IN4 "22 or 20" HDMI IN5 "11 or 10"  
(Detection of 5V is OK)

**Check item(3-8.2).** Checking the DDC status register :  
Send the following command from Termite.exe.  
Case of HDMI IN4  
Send the command "i 0003 0054 0001".  
Case of HDMI IN5  
Send the command "i 0003 0024 0001".  
Move to the branch destination according to the value returned.

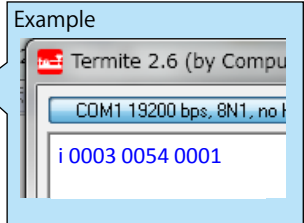

"00 or 04"  
(Detection of DDC is not OK.)

Go to **check item (3-8.4).**

"22"  
(Detection of DDC is OK)

Go to **check item (3-8.5).**

When the results of check item (3-8.1.) are "00"  
(Detection of 5V is not OK)

Check the +5V voltage. (HDMI Rx/Tx)

Check item(3-8.3.). Check the +5V voltage.  
Does "+5V" at the following test point indicate 5 V? [N1019/N1020]

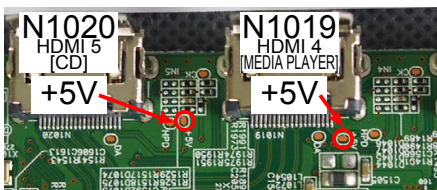

YES

HDMI Rx/Tx [U1027] is faulty.  
Replace with a new device.

NO

Check for a short circuit in the 5 V line and the 5 V Switch IC [U1025].  
If there is no problem, the HDMI Rx/Tx [U1027] or the 5 V Switch IC [U1025] is faulty.  
Replace with a new device.

Recheck from check item (3.2.).  
If it does not work, replace the PCB.

When the results of check item (3-8.2.) are "00 or 04"  
(Detection of DDC is not OK.)

Check the DDC line. (HDMI Rx/Tx)

Check item(3-8.4.). Check the DDC line :  
Are waveforms of "CK" and "DA" observed at the test point near the HDMI input terminal?

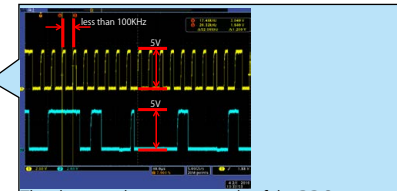
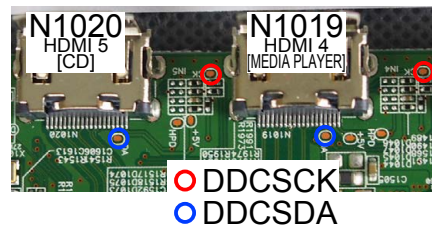

This diagram shows an example of the DDC communication waveform.  
-The high level voltage is 5V.  
-The frequency of the DDC CLK is 100 KHz or less.  
Check at each test point.  
Voltage scale : 2.0V/div  
Time scale : 40us/div

YES

HDMI Rx/Tx [U1027] is faulty.  
Replace with a new device.

NO

Check for a short circuit in the DDC line.  
If there is no problem, the HDMI Rx/Tx [U1027] is faulty.  
Replace with a new device.

Recheck from check item (3.2.).  
If it does not work, replace the PCB.

When the results of check item (3-8.2.) are "22"  
(Detection of DDC is OK.)

Checking the TMDS status register

**Check item(3-8.5).** Checking register of the TMDS CLK detection status register:  
Send the following command from Termit.exe.

HDMI Rx/Tx  
Send the command "i 0006 00FF 0001".

When the following value is returned, go to Yes.  
HDMI IN4 "22" HDMI IN5 "11"

When the following value is returned, go to No.  
HDMI IN4 "20" HDMI IN5 "10"

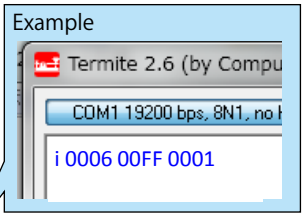

NO

**Check item(3-8.7).** Checking the audio signal output:  
Check the audio signal waveform at the following test point.  
Is the waveform like the sample?



129/131/132/133/134/135/136pin

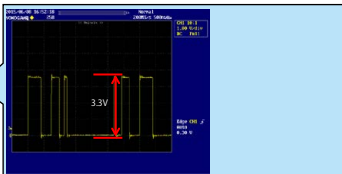

The diagram shows an example of the waveform of pin 129. (I2SO Data)  
Waveform check points  
- Crest value (3.3V normally)  
- Signal change  
Check the waveform of each pin.  
Voltage scale : 1.0V/div  
Time scale : 20ms/div

YES  
The digital audio block is faulty.  
Check the digital audio device.  
Check "AUDIO" in troubleshooting.  
If it does not work, replace the PCB.

NO  
HDMI Rx/Tx [U1027] is faulty.  
Replace with a new device.

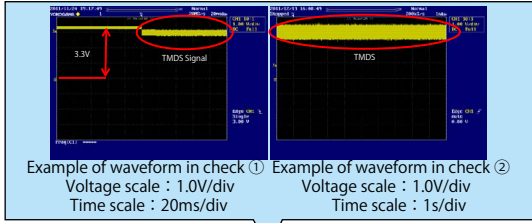

Example of waveform in check ① Voltage scale : 1.0V/div Time scale : 20ms/div  
Example of waveform in check ② Voltage scale : 1.0V/div Time scale : 1s/div

**Check item(3-8.6).** Checking the TMDS input waveform.:  
Check the TMDS waveform at the following test point.  
Is the waveform like the sample?

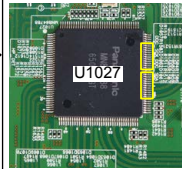

HDMI IN4  
80/81/83/84/86/87/89/90pin  
HDMI IN5  
93/94/96/97/99/100/102/103pin

YES  
HDMI Rx/Tx [U1027] is faulty.  
Replace with a new device.

NO  
Check for a short circuit in the pattern of the TMDS line of the HDMI Rx/Tx [U1027] from the HDMI input terminal.  
If there is no problem, the HDMI Rx/Tx [U1027] is faulty. Replace with a new device.

Recheck from **check item (3.2.)**.  
If it does not work, replace the PCB.

### 3-9. HDMI SW [MN864787] failure detection procedure

Checking operation between the HDMI (HDMI SW) device and the player



※ In order to check, connect the player to the HDMI terminal and configure the player as AVR source. Check the sound output while turning on the player.

Checking the +5V/DDC status register (HDMI SW)

**Check item(3-9.1).** Checking the 5V status register :  
Send the following command from Termite.exe.

Send the command "i 002E 00FF 0001".

Move to the branch destination according to the value returned.

Example

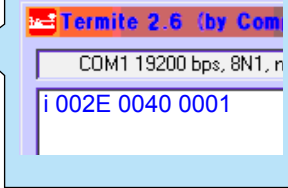

HDMI IN1/IN2/IN3 "00"  
(Detection of 5V is not OK.)

Go to **check item (3-9.3).**

HDMI IN1 "44 or 40" HDMI IN2 "22 or 20" HDMI IN3 "11 or 10"  
(Detection of 5V is OK)

**Check item(3-9.2).** Checking the DDC status register :  
Send the following command from Termite.exe.

Case of HDMI IN1

Send the command "i 002B 0084 0001".

Case of HDMI IN2

Send the command "i 002B 0054 0001".

Case of HDMI IN3

Send the command "i 002B 0054 0001".

Move to the branch destination according to the value returned.

Example

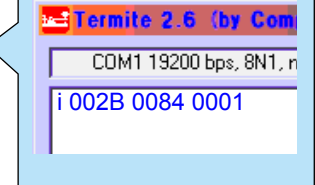

"00 or 04"  
(Detection of DDC is not OK.)

Go to **check item (3-9.4).**

"22"  
(Detection of DDC is OK)

Go to **check item (3-9.5).**

When the results of check item (3-9.1.) are "00"  
(Detection of 5V is not OK)

Check the +5V voltage. (HDMI SW)

Check item(3). Check the +5V voltage :  
Does "+5V" at the following test point indicate 5 V? [N1015/N1016/N1017]

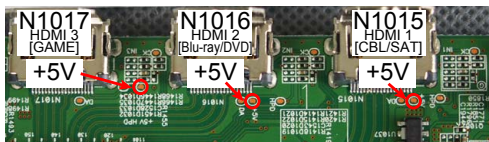

YES

HDMI SW [U1024] is faulty.  
Replace with a new device.

NO

Check for a short circuit in the 5 V line and the 5 V Switch IC [U1025].  
If there is no problem, the HDMI SW [U1024] is faulty.  
Replace with a new device.

Recheck from check item (3.2.).  
If it does not work, replace the PCB.

When the results of check item (3-9.2.) are "00 or 04"  
(Detection of DDC is not OK.)

Check the DDC line. (HDMI SW)

Check item(3-9.4). Check the DDC Line HPD line :  
Are waveforms of "CK" and "DA" observed at the test point near the HDMI input terminal [N1015/  
N1016/N1017]?

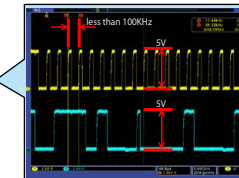
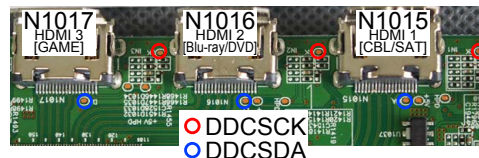

This diagram shows an example of the DDC communication waveform.  
-The high level voltage is 5V.  
-The frequency of the DDC CLK is 100 KHz or less.  
Check at each test point.  
Voltage scale : 2.0V/div  
Time scale : 40us/div

YES

HDMI SW [U1024] is faulty.  
Replace with a new device.

NO

Check for a short circuit in the DDC line.  
If there is no problem, the HDMI SW [U1024] is faulty.  
Replace with a new device.

Recheck from check item (3.2.).  
If it does not work, replace the PCB.

When the results of check item (3-9.2.) are "22"  
(Detection of DDC is OK.)

Checking the TMDS status register (HDMI SW)

**Check item(3-9.5).** Checking register of the TMDS CLK detection status register:  
Send the following command from Termite.exe.  
HDMI Rx/Tx  
Send the command "i 002E 00FF 0001".  
When the following value is returned, go to Yes.  
HDMI IN1 "44" HDMI IN2 "22" HDMI IN3 "11"  
When the following value is returned, go to No.  
HDMI IN1 "00" HDMI IN2 "00" HDMI IN3 "00"

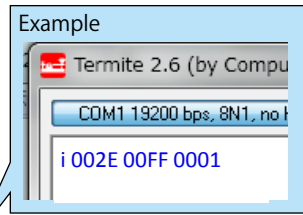

NO

Checking the TMDS status register (HDMI SW -> HDMI Rx/Tx)

**Check item(3-9.7).** Checking register of the TMDS CLK detection status register:  
Send the following command from Termite.exe.  
Send the command "i 0006 00FF 0001".  
When the following value is returned, go to Yes.  
"CC or 44"  
When the following value is returned, go to No.  
"other"

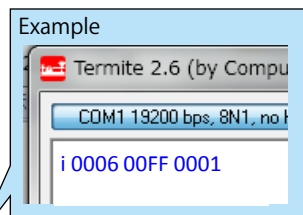

NO

**Check item(3-9.8).** Checking the TMDS input waveform.:  
Check the TMDS waveform at the following test point.  
Is the waveform like the sample?



55/56/58/59/61/62/64/65pin

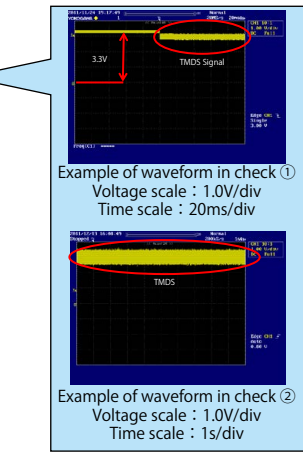

YES  
HDMI Rx/Tx [U1027] is faulty.  
Replace with a new device.

NO  
HDMI SW [U1024] is faulty.  
Replace with a new device.

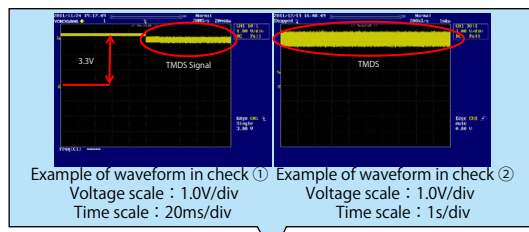

**Check item(3-9.6).** Checking the TMDS input waveform.:  
Check the TMDS waveform at the following test point.  
Is the waveform like the sample?



HDMI IN3  
137/138/140/141/143/144/146/147pin  
HDMI IN2  
124/125/127/128/130/131/133/134pin  
HDMI IN1  
83/84/86/87/89/90/92/93pin

YES  
HDMI SW [U1024] is faulty.  
Replace with a new device.

NO  
Check for a short circuit in the pattern of the TMDS line of the HDMI SW [U1024] from the HDMI input terminal.  
If there is no problem, the HDMI SW [U1024] is faulty.  
Replace with a new device.

Recheck from check item (3.2.).  
If it does not work, replace the PCB.

Before Servicing  
This Unit

Electrical

Mechanical

Repair Information

Updating

### 3-10. HDMI DDC Buffer [TCA9517] failure detection procedure

Checking operation between the HDMI (HDMI DDC Buffer) and the player

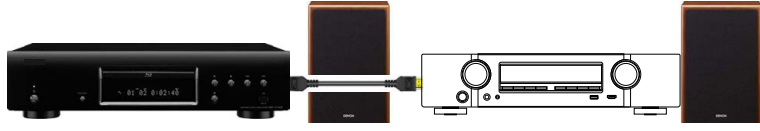

※ In order to check, connect the player to the HDMI terminal and configure the player as AVR source. Check the sound output while turning on the player.

Check the power supply voltage. (HDMI Buffer)

Checking the +5V/DDC status register (HDMI DDC Buffer)

**Check item(3-10.3).** Checking the 5V status of the register :  
Send the following command from Termite.exe.

Send the command "i 002E 00FF 0001".

Move to the branch destination according to the value returned.

Example

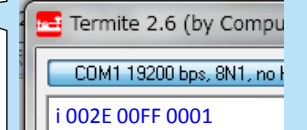

"00"  
(Detection of 5V is not OK.)

Go to [check item \(3-10.5.\)](#)

"88 or 80"  
(Detection of 5V is OK)

**Check item(3-10.4).** Checking the status of the register :  
Send the following command from Termite.exe.

Send the command "i 002B 00B4 0001".

Move to the branch destination according to the value returned.

Example

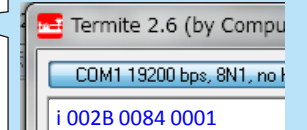

"00 or 04"  
(Detection of DDC is not OK.)

Go to [check item \(3-10.6.\)](#)

"22"  
(Detection of DDC is OK)

Go to [check item \(3-10.7.\)](#)



When the results of check item (3-10.3.) are "00"  
(Detection of 5V is not OK.)

Check the +5V voltage. (HDMI DDC Buffer)

**Check item(3-10.5).** Check the +5V voltage.  
Does "+5 V" at the following test point indicate 5V?  
The test points are as follows. (HDMI SW [U1024])

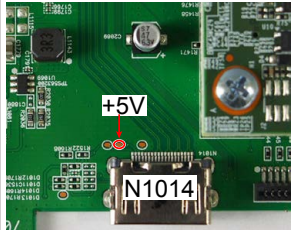

NO  
Check for a short circuit in the 5V line, the Front HDMI Cable, and the 5V Switch [U1025].  
If there is no problem, the HDMI SW1 [U1024] or 5V Switch [U1025] is faulty.  
Replace with a new device.

YES

HDMI SW [U1024] is faulty.  
Replace with a new device.

Recheck from [check item \(3.2.\)](#).  
If it does not work, replace the PCB.

When the results of check item (3-10.4.) are "00 or 04"  
(If the DDC are not OK)

Check the DDC line. (HDMI DDC Buffer)

**Check item(3-10.6).** Check the DDC line :  
Does "DDCCL" and "DDCDA" signal of the HDMI SW [U1024] indicate 5 V?  
The test points are as follows.

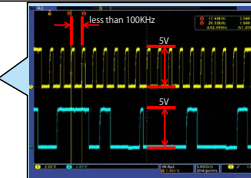
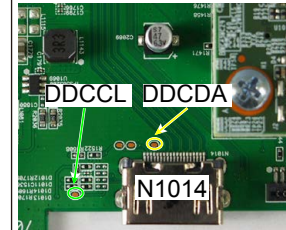

This diagram shows an example of the DDC communication waveform.  
-The high level voltage is 5V.  
-The frequency of the DDC CLK is 100 KHz or less.  
Check at each test point.  
Voltage scale : 2.0V/div  
Time scale : 40us/div

NO

Check for a short circuit in the DDC line and check the Front HDMI Cable.  
If there is no problem, the HDMI DDC Buffer [IC311] is faulty.  
Replace with a new device.

YES

HDMI SW [U1024] is faulty.  
Replace with a new device.

Recheck from [check item \(3.2.\)](#).  
If it does not work, replace the PCB.

When the results of check item (3-10.4.) are "22"  
(Detection of DDC is OK)

Checking the TMDS status register

**Check item(3-10.7).** Check the TMDS CLK detection status of the register.  
Send the following command from Termit.exe.  
Send the command "i 002E 00FF 0001".  
When the following value is returned, go to Yes.  
"88"  
When the following value is returned, go to No.  
"80"

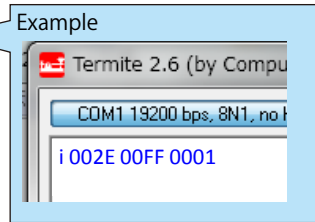

NO

**Check item(3-10.8).** Checking the TMDS input waveform :  
Check the TMDS waveform at the following test point.  
Is the waveform like the sample?  
HDMI SW [U1024]

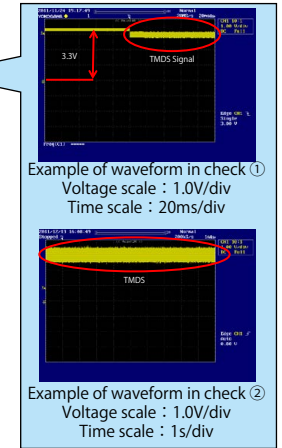
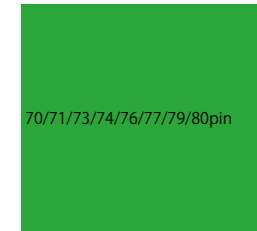

Example of waveform in check ①  
Voltage scale : 1.0V/div  
Time scale : 20ms/div

Example of waveform in check ②  
Voltage scale : 1.0V/div  
Time scale : 1s/div

YES

HDMI SW [U1024] is faulty.  
Replace with a new device.

HDMI SW [U1024] is faulty.  
Replace with a new device.

Check for a short circuit in the TMDS line and the Front HDMI Cable.  
If there is no problem, the HDMI DDC Buffer [IC311] is faulty.  
Replace with a new device.

Recheck from **check item (3.2.)**.  
If it does not work, replace the PCB.

### 3-11. OSD [ADV7623] failure detection procedure

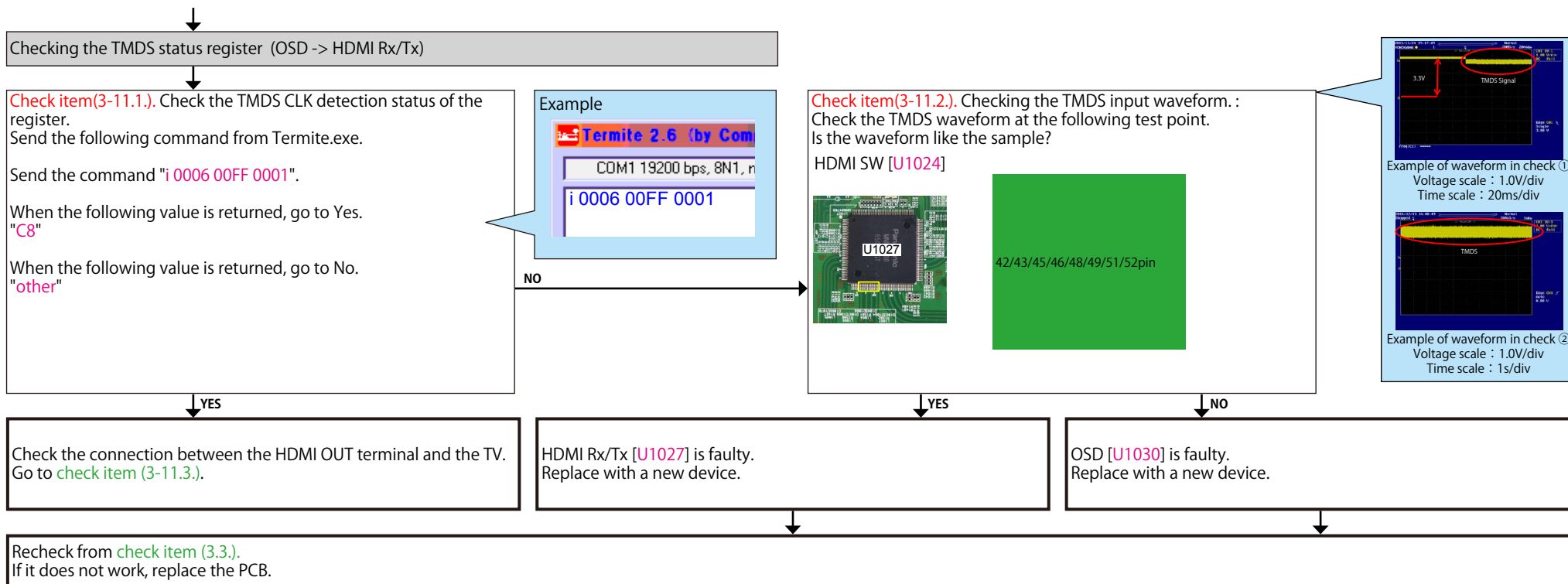

Before Servicing  
This Unit

Electrical

Mechanical

Repair Information

Updating

Check the connection between the HDMI OUT terminal and the TV.  
Connect the HDMI OUT terminal and the TV, and then turn on the TV and check the following items.

Checking the HPD/RXSENSE status register. (HDMI TX -> Monitor)

**Check item(3-11.3).** Check the HPD and RXSENSE register value of the HDMI TX device. :  
Send the following command from Termit.exe.  
Send the command "i 0000 0040 0001".  
Move to the branch destination according to the value returned.

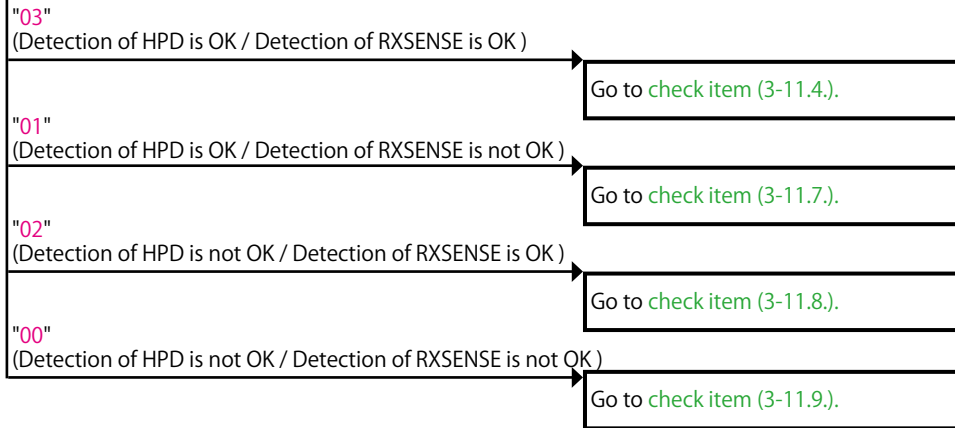
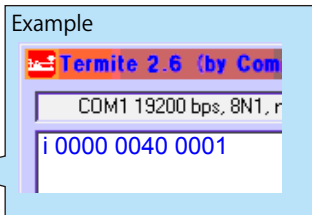

When the results of check item (3-11.3.) are "03"  
(Detection of HPD is OK / Detection of RXSENSE is OK)

Checking the EDID register. (Monitor)

**Check item(3-11.4).** Check the Monitor EDID :  
① Unplug the AC cord. Plug the AC cord into a power outlet.  
② Send the transmission command "m\_1" from Termit.exe.  
Are the first eight bytes of the returned value "00FFFFFFFFF00"?

Example

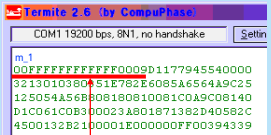

```
COM1 19200 bps, 8N1, no handshake [Settings]
m_1
00FFFFFFFFF0009b1177945540000
3213010380151E782E6085A6564A9C25
125054A56B08180810081C0A9C08140
D1C061C0B30023A801871382D40582C
4500132B2100001E000000FF00394339
```

The first eight bytes are normally "00FFFFFFFFF00".  
\*If the AVR and the TV are not connected via HDMI, the correct register value cannot be verified.

YES

NO

**Check item(3-11.5).** Checking the TMDS :  
Check the TMDS waveform at the following test point.

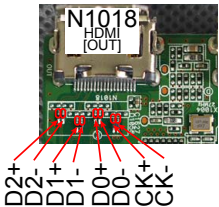

**Check item(3-11.6).** Check communication with the monitor :  
Are waveforms of "DDCSCK" and "DDCSDA" observed at the test point near the HDMI output terminal [N1018]?

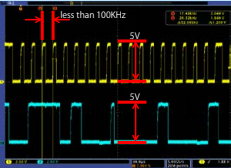
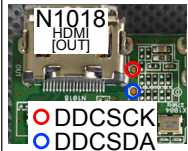

This diagram shows an example of the DDC communication waveform.  
-The high level voltage is 5V.  
-The frequency of the DDC CLK is 100 KHz or less.  
Check at each test point.  
Voltage scale : 2.0V/div  
Time scale : 40us/div

YES

NO

YES

NO

Check for a short circuit in the TMDS line.  
If there is no problem, the HDMI Rx/Tx (U1027) is faulty.  
Replace with a new device.

HDMI Rx/Tx [U1027] is faulty.  
Replace with a new device.

HDMI Rx/Tx [U1027] is faulty.  
Replace with a new device.

HDMI Rx/Tx [U1027] is faulty.  
Replace with a new device.

Recheck from check item (3.3).  
If it does not work, replace the PCB.

When the results of check item (3-11.3.) are "01"  
(Detection of HPD is OK / Detection of RXSENSE is not OK)

Check the RXSENSE. (Monitor)

Check item(3-11.7.). Checking the RXSENSE :  
Does the test point of RXSENSE close to the HDMI output terminal  
[N1018] indicate the 3.3 V?

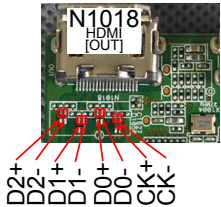

YES NO

Check for a short circuit in the TMDS line.  
If there is no problem, the HDMI Rx/Tx (U1027) is faulty.  
Replace with a new device.

HDMI Rx/Tx [U1027] is faulty.  
Replace with a new device.

Recheck from check item (3.3.).  
If it does not work, replace the PCB.

When the results of check item (3-11.3.) are "02"  
(Detection of HPD is not OK / Detection of RXSENSE is OK)

Check the HPD. (Monitor)

Check item(3-11.8.). Checking the HPD :  
Does the voltage of HPD test point close to the HDMI output terminal  
[N1018] indicate "Hi" (3-5V)?

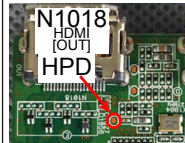

YES NO

Check for a short circuit in the HPD line.  
If there is no problem, the HDMI Rx/Tx (U1027) is faulty.  
Replace with a new device.

HDMI Rx/Tx [U1027] is faulty.  
Replace with a new device.

Recheck from check item (3.3.).  
If it does not work, replace the PCB.

Before Servicing  
This Unit

Electrical

Mechanical

Repair Information

Updating

When the results of check item (3-11.3.) are "00"  
(Detection of HPD is not OK / Detection of RXSENSE is not OK)

Check the RXSENSE/HPD. (Monitor)

Check item(3-11.9.). Checking the HPD and RXSENSE. :  
Does the test point of RXSENSE close to the HDMI output terminal [N1018] indicate the (3.3V)?  
Does the voltage of HPD test point close to the HDMI output terminal [N1018] indicate "Hi" (3-5V)?

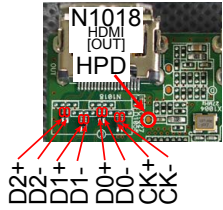

YES NO

Check for a short circuit in the TMDS/HPD line.  
If there is no problem, the HDMI Rx/Tx (U1027) is faulty.  
Replace with a new device.

HDMI Rx/Tx [U1027] is faulty.  
Replace with a new device.

Recheck from check item (3.3.).  
If it does not work, replace the PCB.

### 3-12. Fault detection procedure between HDMI Rx/Tx [MN864788] & OSD [ADV7623].

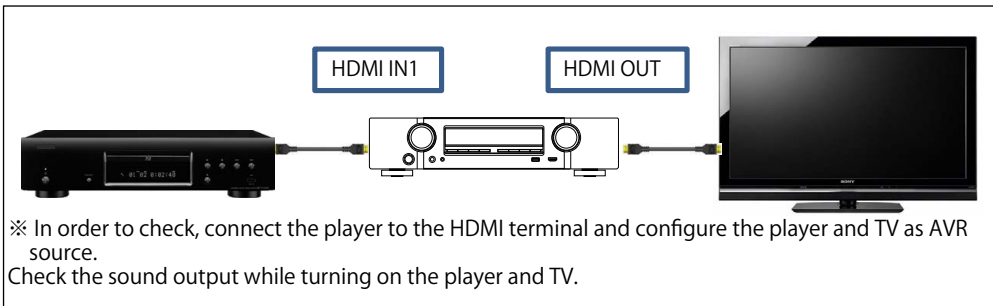

Checking the TMDS status register (Rx/Tx -> OSD)

**Check item(3-12.1).** Check the TMDS CLK detection status of the register.  
Send the following command from Termit.exe.  
Send the command "i 00B2 006A 0001".  
When the following value is returned, go to Yes.  
"11"  
When the following value is returned, go to No.  
"00"

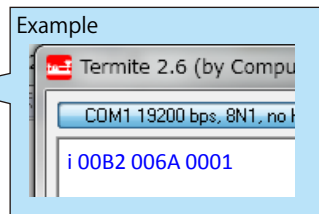

**Check item(3-12.2).** Checking the TMDS input waveform. :  
Check the TMDS waveform at the following test point.  
Is the waveform like the sample?

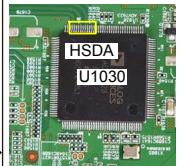

23/24/26/27/29/30/32/33 pin

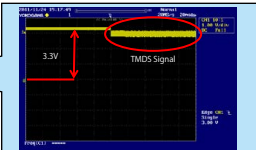

Example of waveform in check ①  
Voltage scale : 1.0V/div  
Time scale : 20ms/div

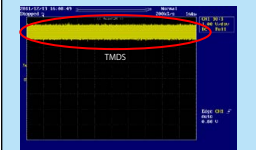

Example of waveform in check ②  
Voltage scale : 1.0V/div  
Time scale : 1s/div

YES  
HDMI Rx/Tx [U1027] is faulty.  
Replace with a new device.

NO  
OSD [U1030] is faulty.  
Replace with a new device.

Recheck from check item (3.4).  
If it does not work, replace the PCB.



## 4. Device implementation location

DIGITAL (A SIDE)

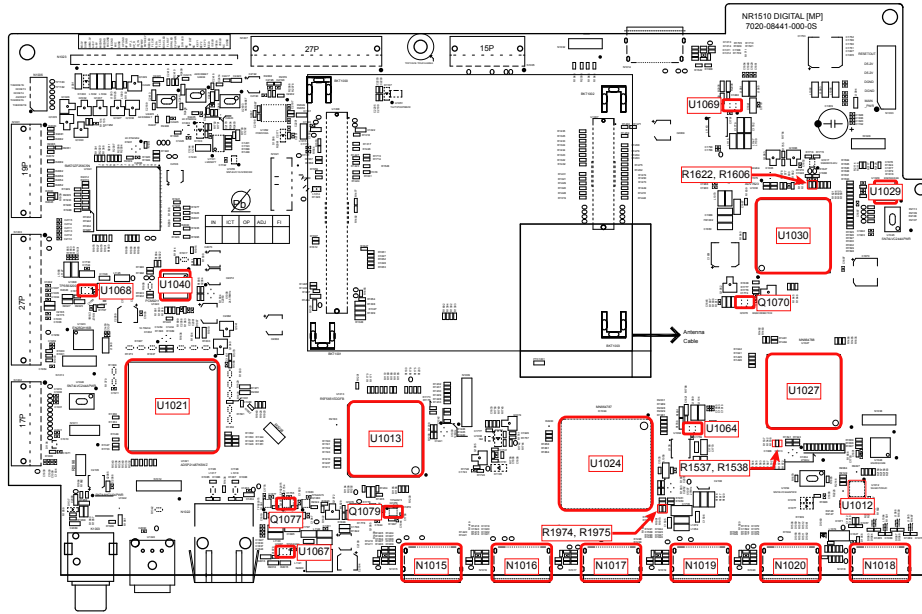

DIGITAL (B SIDE)



F-HDMI (A SIDE)

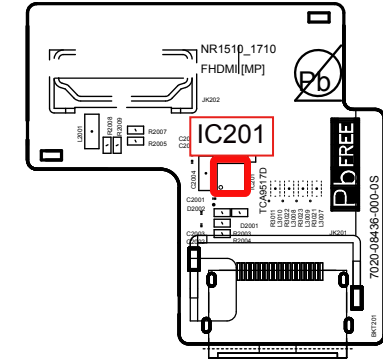

Before Servicing  
This Unit

Electrical

Mechanical

Repair Information

Updating

# CLOCK FLOW & WAVE FORM IN DIGITAL BLOCK

## WAVE FORM

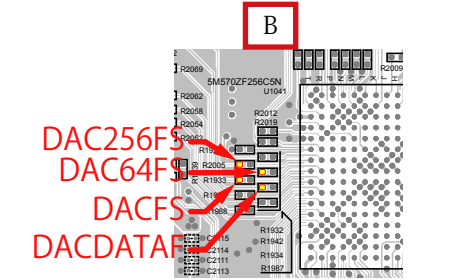
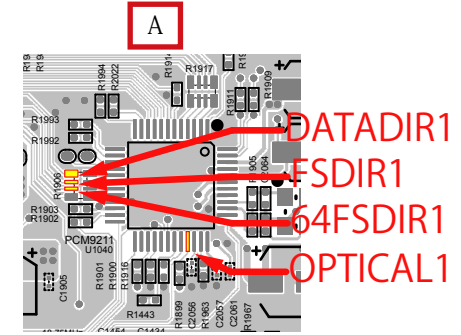
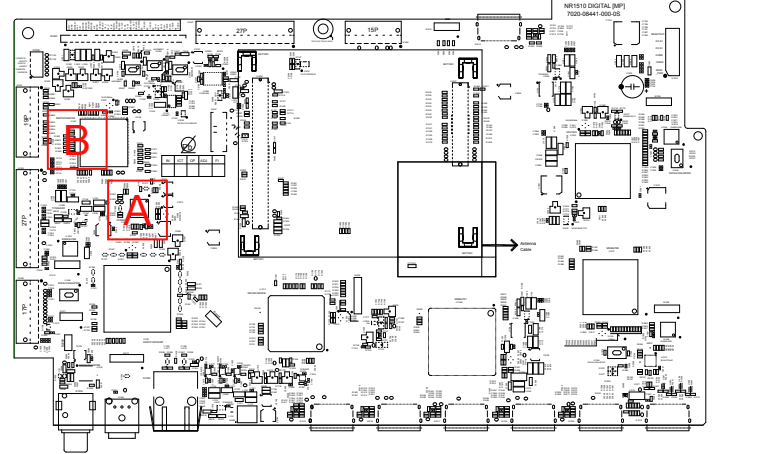
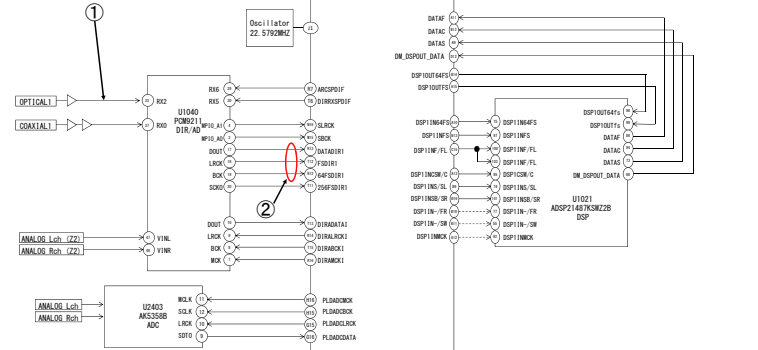
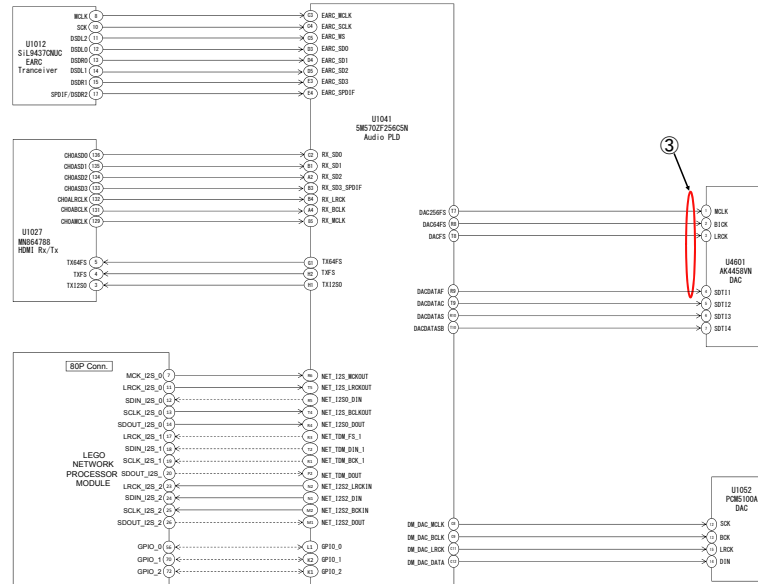
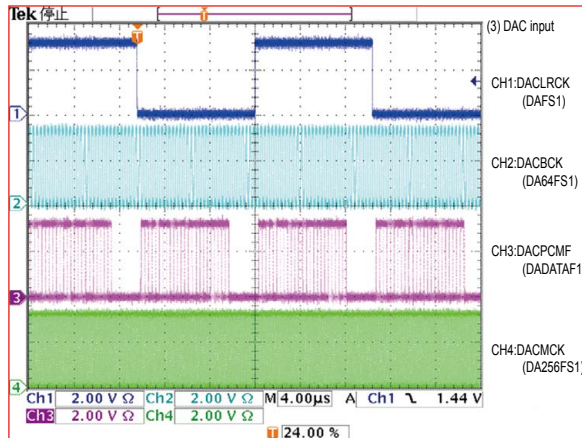
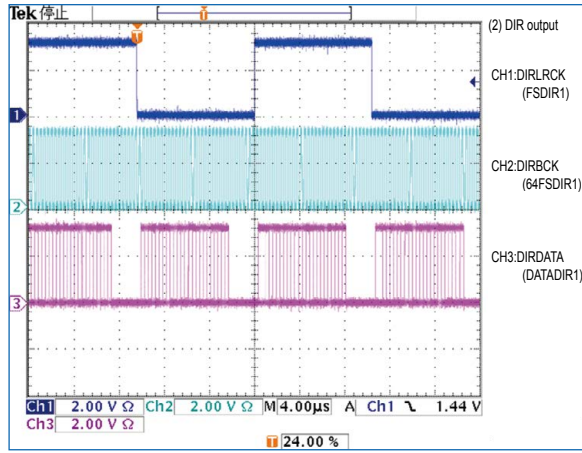
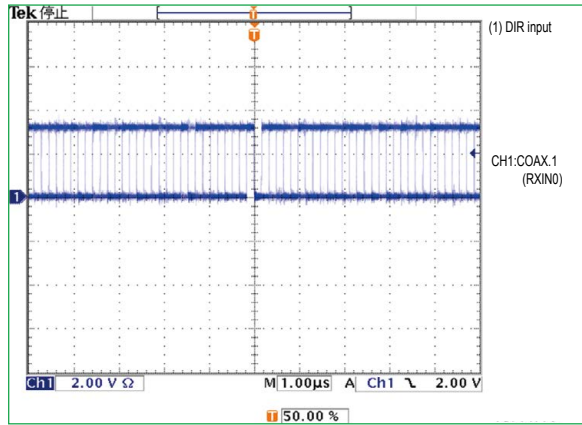

Before Servicing  
This Unit

Electrical

Mechanical

Repair Information

Updating

# SPECIAL MODE

## Special mode setting button

※ No. 1 - 4, 6 - 8: While holding down buttons "A", "B" and "C" simultaneously, press the power button to turn on the power.

※ No. 5, 9, 10: While the power is on, hold down buttons "A", "B", and "C" for at least 3 seconds.

No.	Mode	Button A	Button B	Button C	Descriptions
1	Version Display Mode (MCU / DSP Error Display)	DIMMER	STATUS	-	Displays the version of firmware such as the MCU or DSP. Errors that have occurred are displayed. (See <a href="#">1. Version Display Mode</a> )
2	PANEL / REMOTE LOCK Selection Mode	M-DAX	DIMMER	-	Activates the unit in PANEL/REMOTE LOCK selection mode to enable PANEL LOCK and Remote Lock On/Off to be set. (See <a href="#">2. PANEL / REMOTE LOCK Selection Mode</a> )
3	Selecting the Mode for Service-related	TUNER PRESET CH +	STATUS	-	A selection mode for entering service-related modes. Service-related modes : No. 3-1 - No. 3-4 (See <a href="#">3-1. Selecting the Mode for Service-related</a> )
3-1	Check the Video/Audio path Mode	↑	↑	-	This is a special mode for service confirmation used during repair work to simplify the confirmation work for the Audio channel / video channel. (See <a href="#">Service Path Check Mode</a> )
3-2	Protection history display mode	↑	↑	-	Displays the latest occurred protection history. (See <a href="#">3-2. Protection History Display Mode</a> )
3-3	Operation Info Mode	↑	↑	-	Displays the accumulated operating time of the unit, the number of times the power was switched on, and the number of occurrences of each protection. (See <a href="#">3-3. Operation Info Mode</a> )
3-4	TUNER STEP Mode (U and N model only)	↑	↑	-	Enables the FM/AM tuner reception frequency step to be changed. (See <a href="#">3-4. TUNER STEP mode (U / N only)</a> )
4	Protection Pass Mode	DIMMER	STATUS	SOUND MODE	Enables the power to be turned on when protection detection is disabled. (See <a href="#">4. Protection Pass Mode</a> )
5	Network Initialization Mode	TUNER PRESET CH +	DIMMER	-	Network module backup data is initialized. (See <a href="#">5. Network Initialization Mode</a> )
6	User Initialization Mode	M-DAX	TUNER PRESET CH +	-	Initialize the backup data for the MCU and network module. (Settings for the Installer are not initialized.)
7	Factory Initialization Mode	TUNER PRESET CH +	INTERNET RADIO	-	Initialize the backup data only for MCU. (Settings for the Installer are initialized) (Network function settings are not initialized.) (See <a href="#">POST-SERVICE PRECAUTIONS</a> )
8	Clearing of Operation Info	DIMMER	INTERNET RADIO	-	Clear the accumulated operating time of the unit, the number of times the power was switched on, and the number of occurrences of each protection. (See <a href="#">6. Clearing the Operation Info</a> )
9	HDMI Diagnostics Mode	M-DAX	DIMMER	-	This mode is used to identify and solve the cause when there is a connectivity issue with this unit and an HDMI device. For details on the operating methods and diagnosis procedures, see the HDMI Diagnostics and Troubleshooting guide issued on SDI.
10	Log Capture feature	DIMMER	SOUND MODE	-	Acquires the Network Module log. As the Network Module reboots, the log is deleted. Make sure to obtain the log before turning off the unit's power. (See <a href="#">7. Log Capture feature</a> )

**NOTE:** If the volume indicator displays "-00.0", the unit has entered the developer's special mode. In this case, the RS-232C communication is not available.

To release this special mode, press and hold the "M-DAX" and "PRESET CH +" buttons for 3 seconds or more while the power is ON. When the volume indicator returns to the normal display, the RS-232C communication is available.

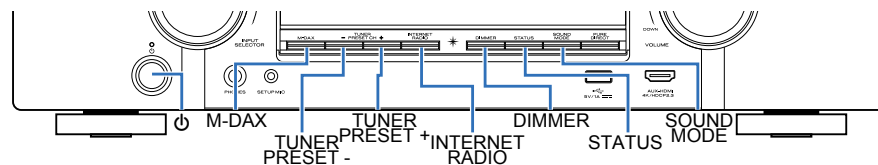

# 1. Version Display Mode

## 1.1. Actions

Version information is displayed when the device is started in this mode.

## 1.2. Starting up

While holding down buttons "DIMMER" and "STATUS" simultaneously, press the power button to turn on the power.

then press the "STATUS" button to display the information in section 1.3 on the display.

※ The version list is also displayed on GUI while the version is displayed on the display.

## 1.3. Display Order

Error information(See "1.4. Error display") → ① Model destination information → ② Serial Number → ③ Firmware Package → ④ MCU → ⑤ MCU 1st Boot Loader → ⑥ DSP → ⑦ Audio PLD → ⑧ GUI SFLASH → ⑨ PIMG → ⑩ Hybrid GUI → ⑪ HEOS Version → ⑫ HEOS Build → ⑬ HEOS Module → ⑭ HEOS Config → ⑮ HEOS Locale → ⑯ Restore Version → ⑰ Ether Mac Address → ⑱ Wi-Fi Mac Address → ⑲ BT Mac Address

① Model destination information :

```
NR0000 \
```

@ : Model name (1510)  
\  
: Region (U, N, K, F)

② Serial Number :

```
SN???*?*****
```

% : SKU code

③ Firmware Package :

```
Package :****
```

④ MCU :

```
M:*****
```

⑤ MCU 1st Boot Loader :

```
Main FBL :**.**
```

⑥ DSP ROM :

```
DSP :**.**
```

⑦ Audio PLD :

```
A.PLD :*****
```

⑧ GUI SFLASH :

```
GUI :00$\****
```

@ : Model code  
\* : Brand code (Non=0, De=1, Mz=2, Mc=3)  
\  
: Region code (U=1, N=2, K=5, F=4, ALL=0)  
\* : version

⑨ PIMG :

```
PIMG :*****
```

⑩ Hybrid GUI :

```
HIMG :*****
```

⑪ HEOS Version :

```
HEOS Version
```

↓ "Press "STATUS" button.

```
*_* ***_**_*
```

⑫ HEOS Build :

```
HEOS Build
```

↓ "Press "STATUS" button.

```
*****
```

⑬ HEOS Module :

```
HEOS Module
```

↓ "Press "STATUS" button.

```
***
```

⑭ HEOS Config :

```
HEOS Config
```

↓ "Press "STATUS" button.

```
Development
```

```
Production
```

⑮ HEOS Locale :

```
HEOS Locale
```

↓ "Press "STATUS" button.

```
*****
```

⑯ Restore Version :

```
RSTR
```

↓ "Press "STATUS" button.

```
*****
```

⑰ Ether MAC Address :

```
*Ether MAC
```

↓ "Press "STATUS" button.

```
*****-*****
```

⑱ Wi-Fi MAC Address :

```
*Wi-Fi MAC
```

↓ "Press "STATUS" button.

```
*****-*****
```

⑲ Bluetooth MAC Address :

```
*BT MAC Address
```

↓ "Press "STATUS" button.

```
*****-*****
```

## 1.4. Error display

See the table below for descriptions of the displayed errors and countermeasures for these.

If multiple errors occur, only one item is displayed.

The priority order is ②, ③, ④, ①.

Condition	States	Display	TROUBLE SHOOTING
① Firm Check Error	<p>The model name, brand name and region information written in the firmware are compared to the region settings in the PCB. This error is displayed if the information does not match.</p> <p>"▲" is not displayed if firmware information is correct.</p>	<pre>FIRM ERROR ▲M:***** ▲Main FBL :**,** ▲DSP      :**,** ▲A.PLD   :***** ▲GUI     :***** ▲PING    :*****</pre>	<ul style="list-style-type: none"> <li>•Check the resistor for setting the region [R1202, 1206, DIGITA PCB].</li> <li>•Write the firmware for the correct region.</li> </ul> <p><b>PIMG Error indication</b></p> <ul style="list-style-type: none"> <li>•Check the circuits around the Logic[U1054] and SFROM[U1048]. If there appear to be no problems, [U1054] or [U1048] is faulty.</li> </ul>
② DIR Error	This error is displayed if there is no response from the DIR.	DIR ERROR 01	•Check the DIR [U1040, DIGITAL PCB] and surrounding circuits.
③ DSP Error	Boot error 1 (After reset the DSP, DSP_Flag0 port is "Low")	DSP ERROR 01	•Check the DSP [U1021, DIGITAL PCB] and surrounding circuits.
	Boot Error 2 (After reset the DSP, MCU received state error command)	DSP ERROR 02	
	Signal Detect Error (No response after input set for 1sec)	DSP ERROR 03	
	Mode Change Error (No response after mode change for 1sec)	DSP ERROR 04	
	Invalid situation (Detecting invalid situation with autodetect)	DSP ERROR 05	
	Busy Error ("Busy" port remains "Low" for 1sec)	DSP ERROR 06	
	Output Fs Error (Fs status between MCU output and actual DSP is different)	DSP ERROR 07	
	Input Fs Error (Fs status between AutoDetect Msg and ACCN Msg is different)	DSP ERROR 08	
	SPI communication error	DSP ERROR 09	
④ BACKUP Error	Error occurred in BACKUP. it is an error of the check sum.	BACKUP ERROR	

## 1.5. Version Display in the Setup Menu

Follow the steps below to display the firmware information.

- (1) Press the "SETUP" button on the remote control.
- (2) Select "General - Information - Firmware".

The version information is displayed as a 16-digit number as shown in the screenshot below.

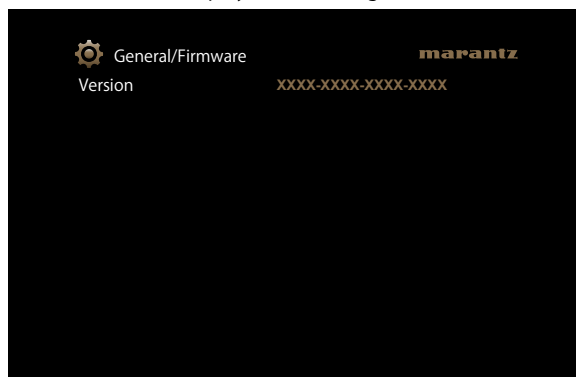

GUI Image

This 16-digit number comprises a part of the version number of each device and module. Numerics and version numbers correspond as shown below.

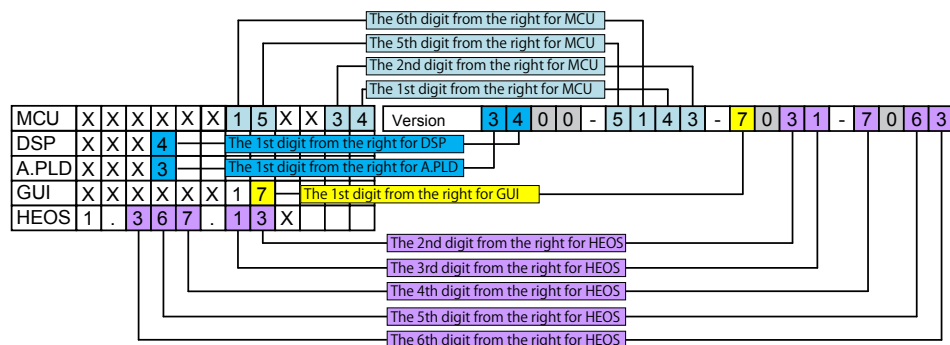

※ The firmware version numbers and this 16-digit version information are written in the Service Information.

※ Replace as follows for the 5th to 7th digits of HEOS version.

- X.XXX.X → X.XXX.00X
- X.XXX.XX → X.XXX.0XX
- X.XXX.XXX → X.XXX.XXX

## 2. PANEL / REMOTE LOCK Selection Mode

### 2.1. Actions

Switch the PANEL LOCK and REMOTE LOCK modes between on and off.

- PANEL LOCK Mode (with Volume)  
Disables reception from all keys and encoders on the front panel except the power button (including the volume).
- PANEL LOCK Mode (without Volume)  
Disables reception from all keys and encoders on the front panel except the power button and volume encoder.
- PANEL LOCK mode is turned off

### 2.2. Starting up

While holding down buttons "M-DAX" and "DIMMER" simultaneously, press the power button to turn on the power.

Select the desired mode using the "TUNER PRESET CH+" button, then press the "STATUS" button to confirm.

### 2.3. Displaying and Selecting Each Mode

The information shown on the display switches each time the "TUNER PRESET CH+" button is pressed.

Press the "STATUS" button to set the currently displayed mode and restart the device.

The setting with "\*" is selected for each mode.

①

FP/VOL LOCK\*On

The buttons on the unit and the master volume knob does not function.



②

FP LOCK On

The buttons on the unit does not function.



③

FP LOCK Off

The PANEL LOCK mode is turned off.



④

RC LOCK On

The device cannot be operated by the remote control.



⑤

RC LOCK \*Off

The REMOTE LOCK mode is turned off.

## 3-1. Selecting the Mode for Service-related

### 3-1.1. Actions

Select diagnostic mode (service path check mode), protection history display mode, or Operation Info mode or TUNER STEP mode.

### 3-1.2. Starting up

While holding down buttons "TUNER PRESET CH +" and "STATUS" simultaneously, press the power button to turn on the power.

Select the desired mode using the "TUNER PRESET CH +/-" button, then press the "STATUS" button to confirm.

### 3-1.3. Displaying and Selecting Each Mode

The information shown on the display switches each time the "TUNER PRESET CH +" button is pressed.

Press the "STATUS" button to set the currently displayed mode and restart the device.

①

1. SERVICE CHECK

Service Path Check Mode : See "[DIAGNOSTIC MODE](#)"

The Video and Audio paths can be checked.

This function is convenient for confirming problem paths in the product and checking the paths after repairing.



②

2. PROTECTION

The protection history can be checked.



③

4. OP INFO

Operation Info for the unit can be checked.



④ U and N model only

5. TUNER FREQ SET

Enables the reception frequency STEP of the ANALOG TUNER to be changed.

### 3-1.4. Canceling the selected mode

Press the power button to turn off the power.



## 3-2. Protection History Display Mode

### 3-2.1. Actions

This mode enables the unit to record and display the event when the THERMAL, ASO or DC protection is activated.

If protections have been activated multiple times, the latest protection operation is recorded.

### 3-2.2. Starting up

While holding down buttons "TUNER PRESET CH +" and "STATUS" simultaneously, press the power button to turn on the power.

Select the "2. PROTECTION" using the "TUNER PRESET CH +/-" button, then press the "STATUS" button then to confirm.

### 3-2.3. Protection information and displays

- Press the "STATUS" button in Protection History Display Mode.
- The protection history can be checked.

(1) If no protections has occurred.

NO PROTECT

(2) ASO (if the last protection is ASO)

PRT:ASO

**Cause** A short circuit occurred between the speaker terminals, or speakers with an impedance outside the rating were connected.

**Note** : Short circuits in speaker terminals or speakers can be identified.

If the power is turned on in the abnormal state, protection is activated after around 6 seconds and the power is turned off.

(3) DC (if the last protection is DC)

PRT:DC

**Cause** : DC output of the power amplifier is abnormal.

If the power is turned on in the abnormal state, protection is activated after around 6 seconds and the power is turned off.

(4) THERMAL (if the last protection is THERMAL(A) or THERMAL(B) or THERMAL(E) )

PRT:THERMAL A

PRT:THERMAL B

PRT:THERMAL E

**Cause** : Abnormal heat sink temperature.

If the power is turned on under abnormal conditions, the protection function works immediately and the power is turned off.

(5) Case of CURRENT (when the last protection incident is CURRENT protection)

:CURRENT

**Cause** : An over current flowed in power amp.

If the power is turned on in the abnormal state, protection is activated after around 90 seconds and the power is turned off.

**Caution** : These protections may also be activated due to other factors such as disconnection of connectors or operations around the MCU.

After viewing the above protection history, press the "STATUS" button to return to the normal display.

### 3-2.4. Clearing the Protection History

There are two ways to clear the protection history.

- (1) Activate Protection History Display Mode. Press the "**STATUS**" button to display the protection history.

PRT:DC

Press and hold the "**DIMMER**" button for 3 seconds.



PRT: CLEAR

The above is displayed and protection history is cleared.



NO PROTECT

- (2) Initialize this unit. (See "[POST-SERVICE PRECAUTIONS](#)")

※ Use the method in **3-2.4. (1)** if you do not want to erase your settings from this unit.

### Warning Displays by POWER LED

If the power is turned Off while a protection is being detected, the POWER LED flashes in red to warn you depending on the protection status as follows.

- (1) ASO/DC protection: Flashes at 0.5-second intervals (0.25 seconds lit, 0.25 seconds unlit)
- (2) THERMAL (A/B/E) protection: Flashes at 2-second intervals (1 seconds lit, 1 seconds unlit)
- (3) CURRENT protection: Flashes at 4-second intervals (2 seconds lit, 2 seconds unlit)

## 3-3. Operation Info Mode

### 3-3.1. Actions

This mode enables the unit to display the accumulated operating time, power On count and each protection count.

### 3-3.2. Starting up

While holding down buttons "TUNER PRESET CH +" and "STATUS" simultaneously, press the power button to turn on the power.

Select the "4. OP INFO" using the "TUNER PRESET CH +/-" button, then press the "STATUS" button then to confirm.

### 3-3.3. Operations

Press the "STATUS" button after starting up this device in Operation Info mode. The following information is displayed in the following order.

- (1) Accumulated operating time

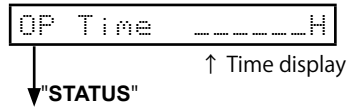

- (2) Power On time

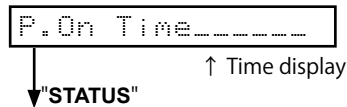

- (3) DC / ASO Protection count



- (4) Thermal Protection (A/B) count

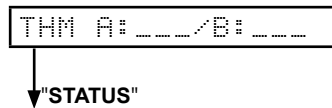

- (5) Thermal Protection (E) count

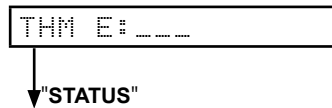

- (6) Current Protection count

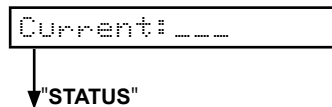

(Returns to normal display)

## 3-4. TUNER STEP mode (U / N only)

### 3-4.1. Actions

This is a special mode that enables the reception frequency STEP of the FM/AM TUNER to be changed.

### 3-4.2. Starting up

While holding down buttons "TUNER PRESET CH +" and "STATUS" simultaneously, press the power button to turn on the power.

Select the "5. TUNER FRQ SET" using the "TUNER PRESET CH +/-" button, then press the "STATUS" button then to confirm.

### 3-4.3. Displays

Start up this unit in TUNER STEP mode, select the desired option using the "TUNER PRESET CH +-" button, then enter using the "STATUS" button.

The following information is displayed in the following order.

- (1) AM9 kHz / FM50 kHz is selected

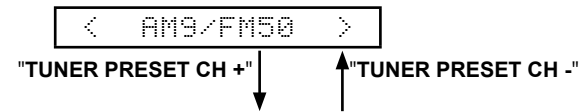

- (2) AM10 kHz / FM200 kHz is selected

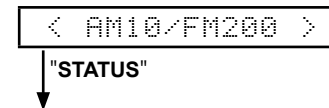

- (3) Press the power button to turn off the power.
- (4) Press the power button to turn on the power.

## 4. Protection Pass Mode

### 4.1. Actions

- This mode allows the power to be turned on without activating protections.
- This mode functions in the same way as normal power-on, except that protections are not activated.
- When using the protection pass mode, do not connect speakers to the speaker terminals.

### 4.2. Operations

While holding down buttons "**DIMMER**", "**STATUS**" and "**SOUND MODE**" simultaneously, press the power button to turn on the power.

The device returns to the normal display message after the following is displayed.

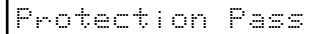

Protection Pass

This is displayed for 5 seconds before returning to the normal display.

## 5. Network Initialization Mode

### 5.1. Actions

The following items are initialized.

- (1) Network setup
- (2) Friendly Name
- (3) Auto Update setting
- (4) Allow Update setting
- (5) Time Zone setting
- (6) Queue list
- (7) Internet Radio recently played station
- (8) Quick Select playback station
- (9) AirPlay Password
- (10) Bluetooth Pairing History

### 5.2. Operations

When the power is on and the input source is HEOS Music, press and hold the "**TUNER PRESET CH +**" and "**DIMMER**" buttons for more than 3 seconds.

Initializing Display



Network Reset...

Complete Display



Completed

This is displayed for 5 seconds before returning to the normal display.

## 6. Clearing the Operation Info

### 6.1. Actions

- Displays the accumulated operating time of the unit, the number of times the power was switched on, and the number of occurrences of each protection.

### 6.2. Operations

Remove all input/output terminals and the AC plug.

Connect the AC plug again and place the product in standby mode.

While holding down buttons "**DIMMER**" and "**INTERNET RADIO**" simultaneously, press the power button to turn on the power.

PRODUCT MODE

When "**PRODUCT MODE**" appears on the display, release the button and press the button "**power**" → "**ZONE2 ON/OFF**" to place the product in standby mode.

## 7. Log Capture feature

### 7.1. Actions

- Acquires the Network Module log.
- The log is deleted when the Network Module is deleted.  
If an error occurs, it is acquired without turning off the power of this unit.
- The log can be copied to a writable USB flash drive.  
It can also be sent to a server if this unit is connected to the Internet.
- The log is stored in the root folder of the USB flash drive with the name "**logs-<friendlyname>-<number>.tar.gz**".  
<friendlyname> indicates the friendly name and <number> indicates the sequence number.  
Previous logs on the USB flash drive are not overwritten. The log is encrypted.

### 7.2. Starting up

While the power is on, hold down buttons "**DIMMER**" and "**SOUND MODE**" for at least 3 seconds.

#### 7.2.1. If the USB flash drive is connected after starting the unit

- (1) The log is written to the USB flash drive and "**Storing Logs...**" is displayed.  
The log is also sent to the server.

Storing Logs...

- (2) When a log package is saved to a USB flash drive, "**USB SUCCESS**" appears in the display for 5 seconds, regardless of whether the upload to the server was successful.

USB SUCCESS

- (3) When saving of the log package fails, "**USB FAILED**" appears in the display for 5 seconds, regardless of whether the upload to the server was successful.

USB FAILED

#### 7.2.2. When the USB flash drive is not connected after startup, and this unit is connected to the Internet.

- (1) The log is sent to the server and the display shows "**Storing Logs...**" for 5 seconds.

Storing Logs...

- (2) When the log package is uploaded, the ticket numbers "**XXXXX**" and "**Push ENTER**" are displayed until the "**Enter**" or "**Back**" button of RC is pressed.

XXXXX Push ENTER

- (3) If the log package upload fails, "**FAILED**" is displayed for 5 seconds.

FAILED

## Service Path Check Mode

### 1.1. Actions

This function is convenient for confirming problem paths in the product and checking the paths after repairing.  
The video system and audio system operation paths can be checked.  
The backup data is not rewritten.

### 1.2. Starting up

While holding down buttons "TUNER PRESET CH +" and "STATUS" simultaneously, press the power button to turn on the power.  
Select the "1. SERVICE CHECK" using the "TUNER PRESET CH +/-" button, then press the "STATUS" button then to confirm.  
The "TUNED", "STEREO" and "RDS" segments are lit in this mode.

### 1.3. Canceling diagnostic mode

Press the power button to turn off the power.

### 1.4. Selecting items to check

Press the ① button to switch between video items and audio items.  
Press the ② or ③ button to select the previous or next item.

Actions	The unit			Remote control unit		
	①	②	③	①	②	③
	Audio ⇄ Video	PREVIOUS	NEXT	Audio ⇄ Video	PREVIOUS	NEXT
Button	DIMMER	TUNER PRESET -	TUNER PRESET +	SLEEP	CURSOR ◀	CURSOR ▶

### 1.5. Audio system confirmation items

See the block diagram fig.AXXth.

Paths to be confirmed			Display	Settings	What to confirm
1	Analog	fig.A01	A01:ANALOG PASS	Input Source : CBL/SAT Input Mode : Analog (fixed) Sound mode : DIRECT	• Analog input ⇒ Speaker output (Front L/R) (※ The input source can be switched to any source except CBL/SAT.)
2	DIGITAL (MAIN)	fig.A02a fig.A02b	A02: DIGITAL	Input Source : CBL/SAT Input Mode : DIGITAL (fixed) Sound mode : MULTI CH STEREO Speaker Config ALL Speaker = Small / SW = Yes(2ch)	• Digital input ⇒ Speaker output (Front L/R, Center, Surround L/R) • Digital input ⇒ Pre OUT output (Front L/R, Subwoofer) (※ The input source can be switched to any source except CBL/SAT.)
3	HDMI	fig.A03a fig.A03b	A05: HDMI	Input Source : CBL/SAT Input Mode : HDMI (fixed) Sound mode : STEREO	• HDMI input ⇒ Speaker output (Front L/R) (※ The input source can be switched to any source except CBL/SAT.)
4	Analog AD (MAIN ZONE)	fig.A04a fig.A04b	A06: AD	Input Source : CBL/SAT Input Mode : Analog (fixed) Sound mode : MULTI CH STEREO Vol 60(-20dB) Speaker Config ALL Speaker = Small/SW = Yes(2ch)	• Analog input ⇒ Speaker output (Front L/R, Center, Surround L/R) • Analog input ⇒ Pre OUT output, SW(20Hz) (Front L/R, Subwoofer) (※ The input source can be switched to any source except CBL/SAT.) (※ Volume 60 is the value when Absolute settings are used. The value is -20 when Relative settings are used)

## 1.6. Confirmation items for the video system

See the block diagram fig.VXXth.

Paths to be confirmed		Display	Settings	What to confirm
1	Analog Video pass <b>fig.V01</b>	V01:VIDEO PASS	Input Source : CBL/SAT	<ul style="list-style-type: none"> <li>• CVBS input ⇒ CVBS output (※ The input source can be switched to any source except CBL/SAT.)</li> </ul>
2	HDMI pass (MAIN ZONE) <b>fig.V02</b>	V03:HDMI PASS	Input Source : CBL/SAT MAIN ZONE ON	<ul style="list-style-type: none"> <li>• HDMI input ⇒ HDMI output (MAIN) (※ The input source can be switched to any source except CBL/SAT.)</li> </ul>
3	HDMI CEC <b>fig.V03</b>	V04:HDMI CEC	Input Source : CBL/SAT HDMI Control : On	<ul style="list-style-type: none"> <li>• When the power supply of a TV is put in the standby mode, make sure that the power supply of this unit is also put in the standby mode. (※ The input source can be switched to any source except CBL/SAT.)</li> <li>• The ARC path can also be checked (check this using the TV input source).</li> </ul>
4	HDMI Audio (Audio : AVR) <b>fig.V04a</b> <b>fig.V04b</b>	V05:H.AUDIO-AVR	Input Source : CBL/SAT HDMI Control : Off HDMI Audio : AVR (if checking the audio output from AVR)	<ul style="list-style-type: none"> <li>• HDMI input (PCM, DolbyDigital, DTS) ⇒ Speaker output.</li> <li>• HDMI input(HD audio) ⇒ Speaker output. (※ The input source can be switched to any source except CBL/SAT.)</li> </ul>
5	HDMI Audio (Audio : TV) <b>fig.V05</b>	V06:H.AUDIO-TV	HDMI Audio : TV (if checking the audio output from TV)	<ul style="list-style-type: none"> <li>• HDMI input (PCM, DolbyDigital, DTS) ⇒ HDMI output (audio output from connected TV) (※ The input source can be switched to any source except CBL/SAT.)</li> </ul>
6	GUI <b>fig.V06</b>	V07:GUI MENU ON	Input Source : CBL/SAT Setup Menu : On	<ul style="list-style-type: none"> <li>• GUI display ⇒ HDMI output. (※ The input source can be switched to any source except CBL/SAT.)</li> </ul>

NR1510 ANALOG AUDIO DIAGRAM

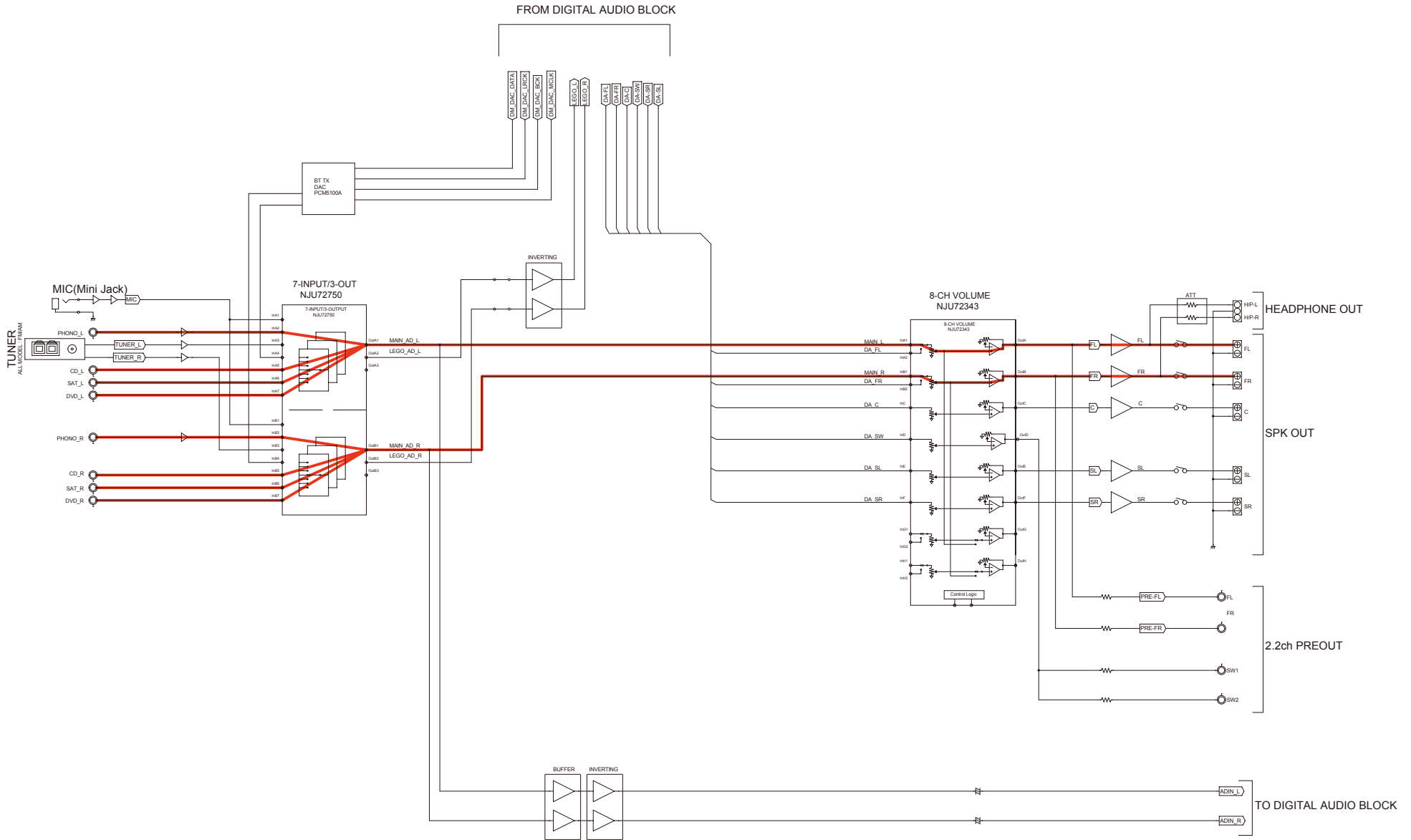
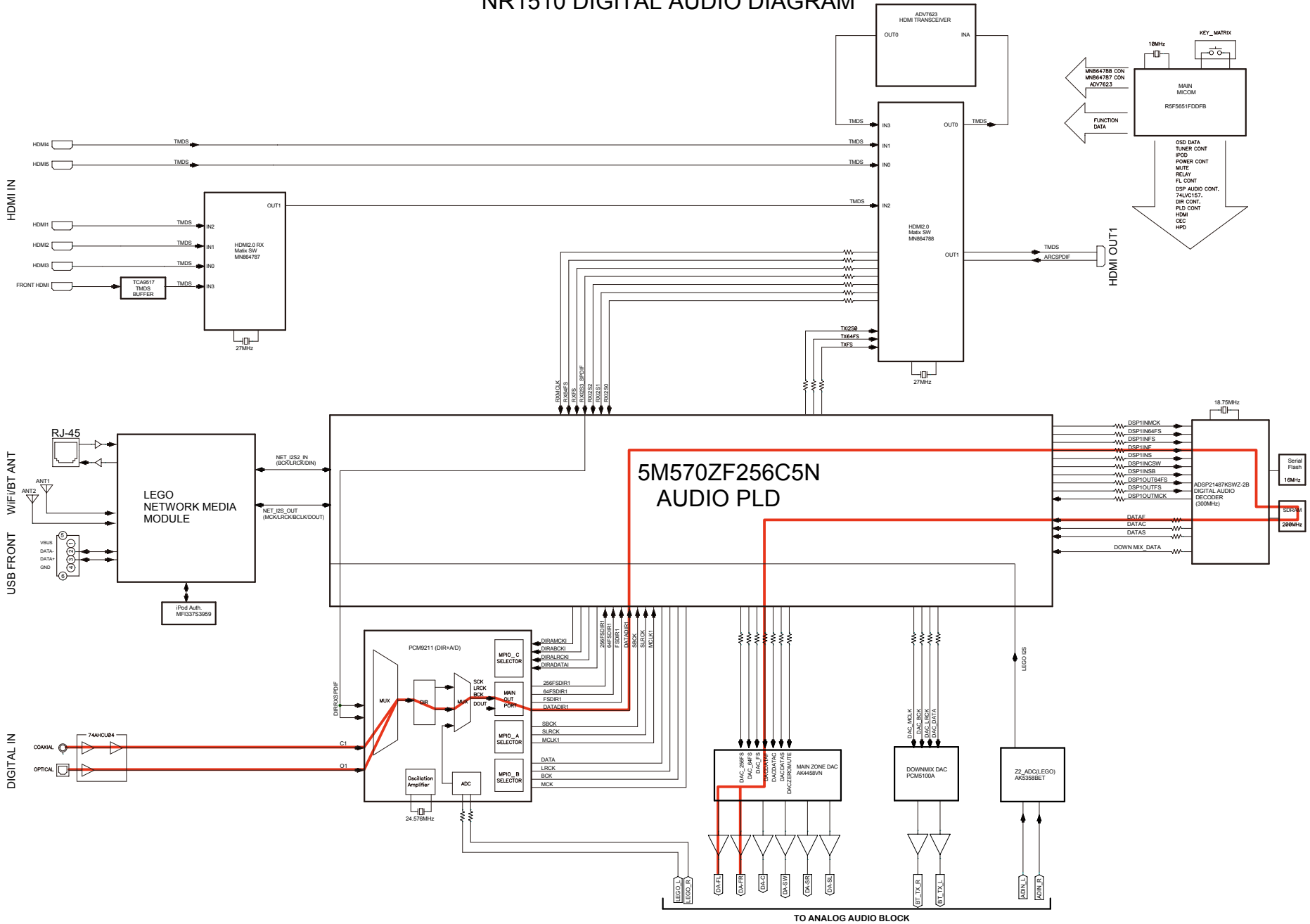



fig.A02a

NR1510 DIGITAL AUDIO DIAGRAM



TO ANALOG AUDIO BLOCK

fig.A02b

# NR1510 ANALOG AUDIO DIAGRAM

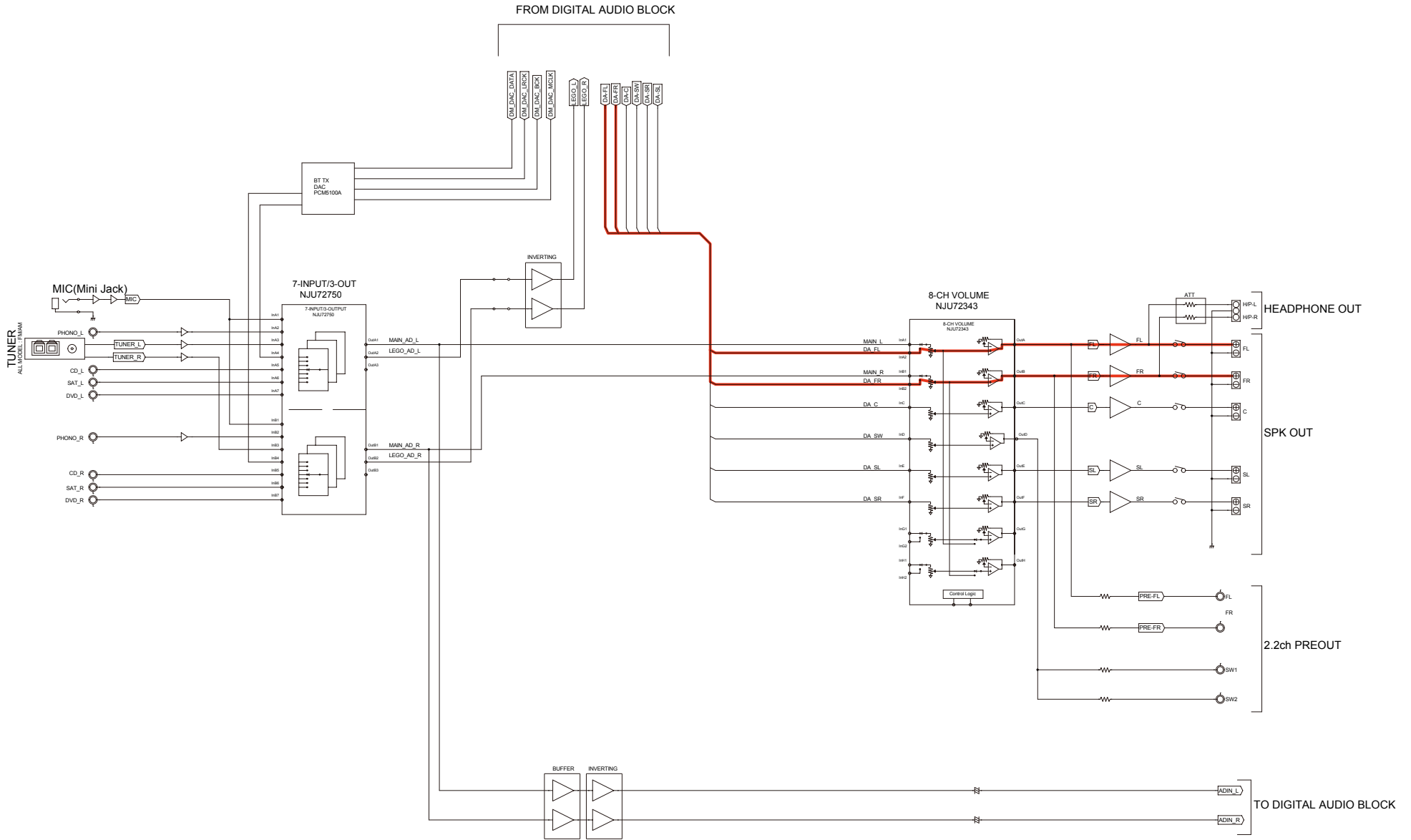

fig.A03a

### NR1510 DIGITAL AUDIO DIAGRAM

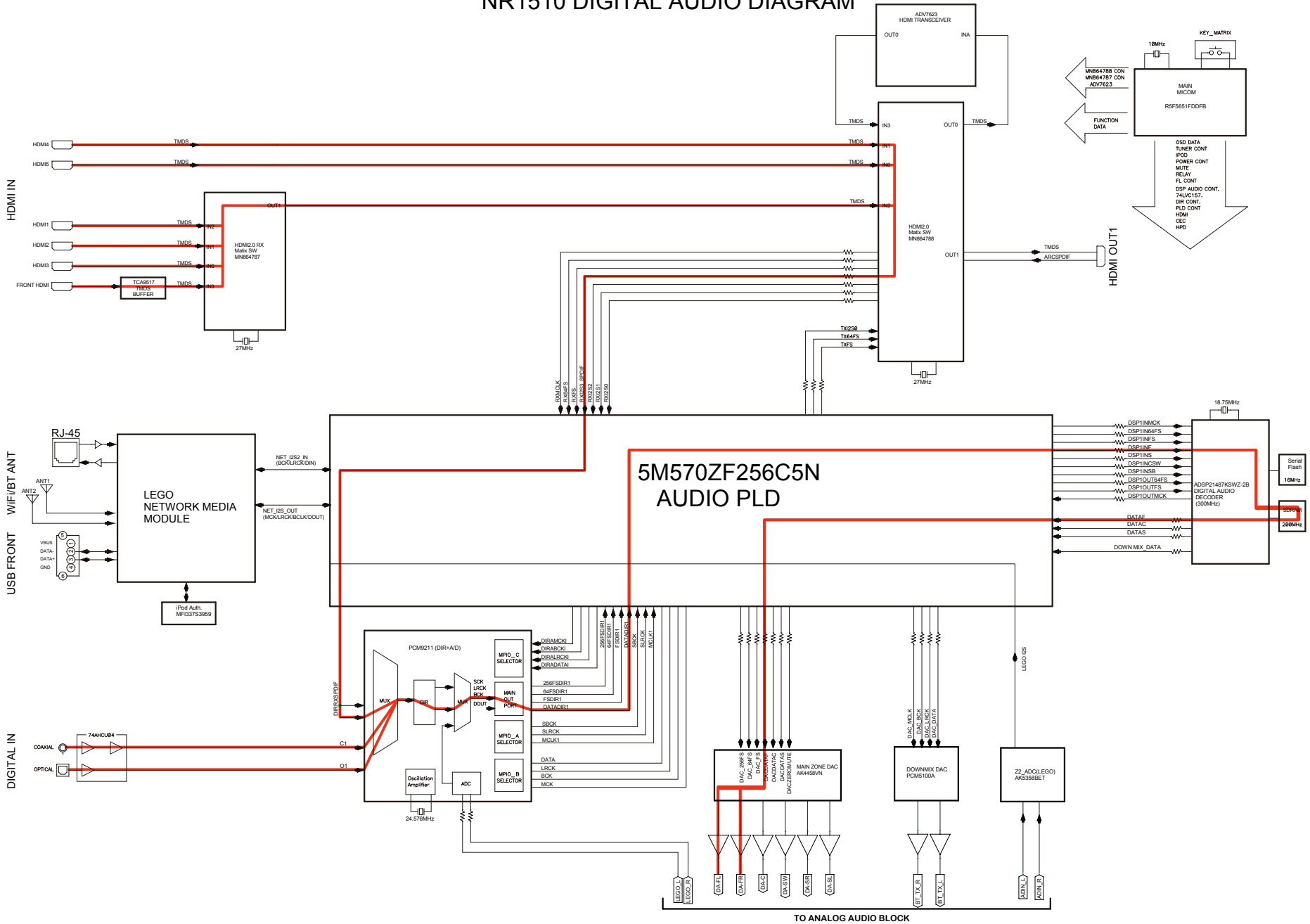

fig.A03b

# NR1510 ANALOG AUDIO DIAGRAM

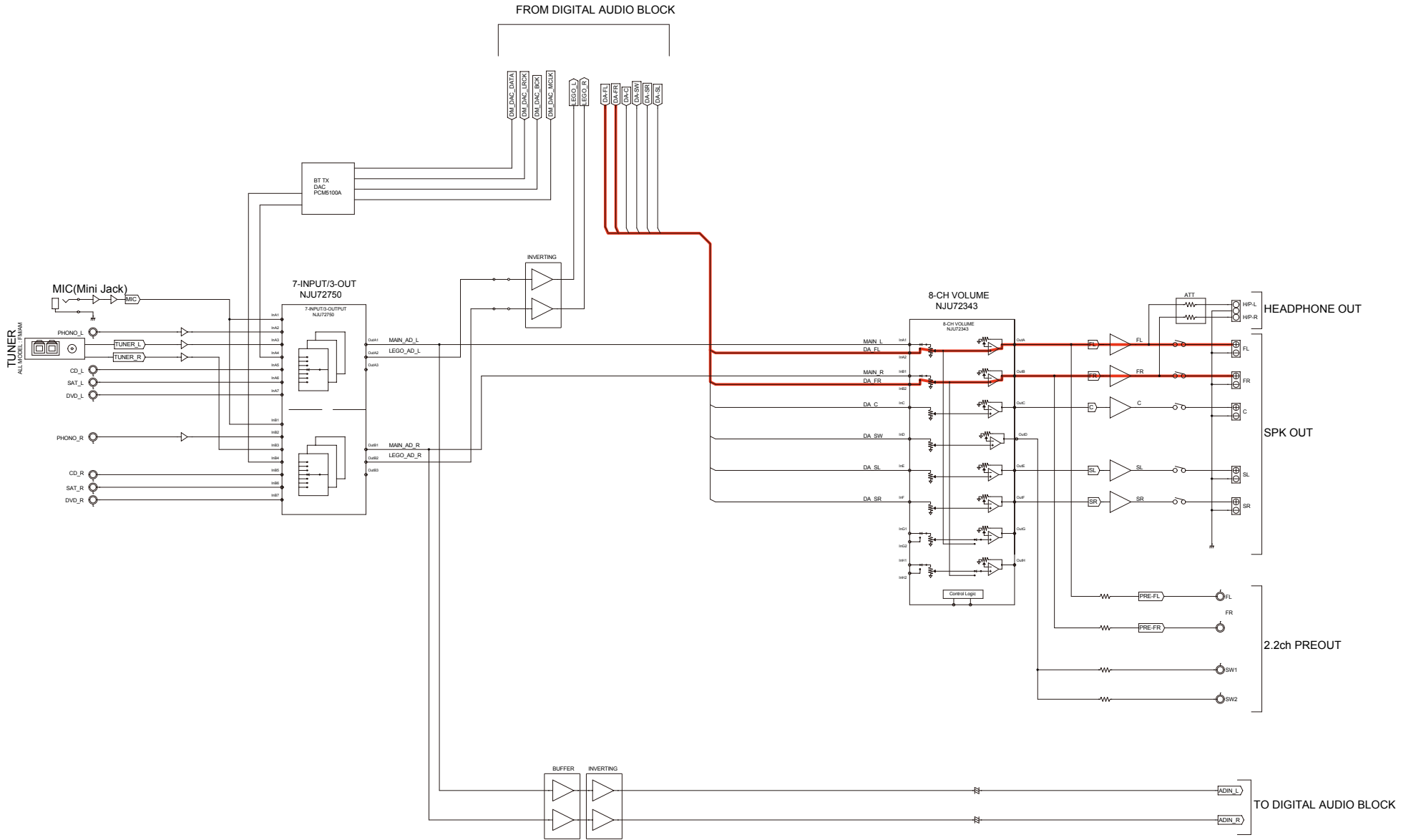
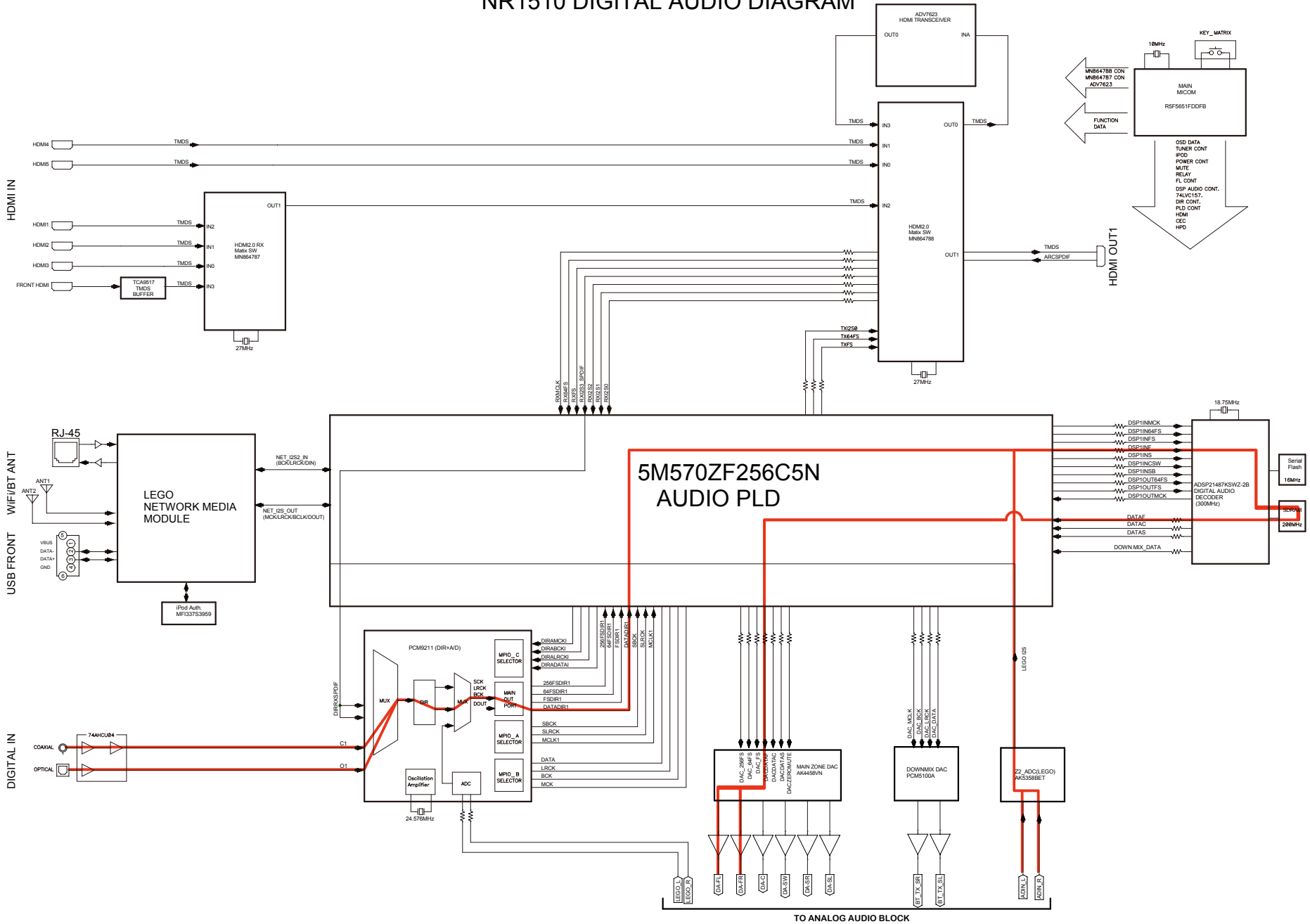

fig.A04a

NR1510 DIGITAL AUDIO DIAGRAM



TO ANALOG AUDIO BLOCK

fig.A04b

# NR1510 ANALOG AUDIO DIAGRAM

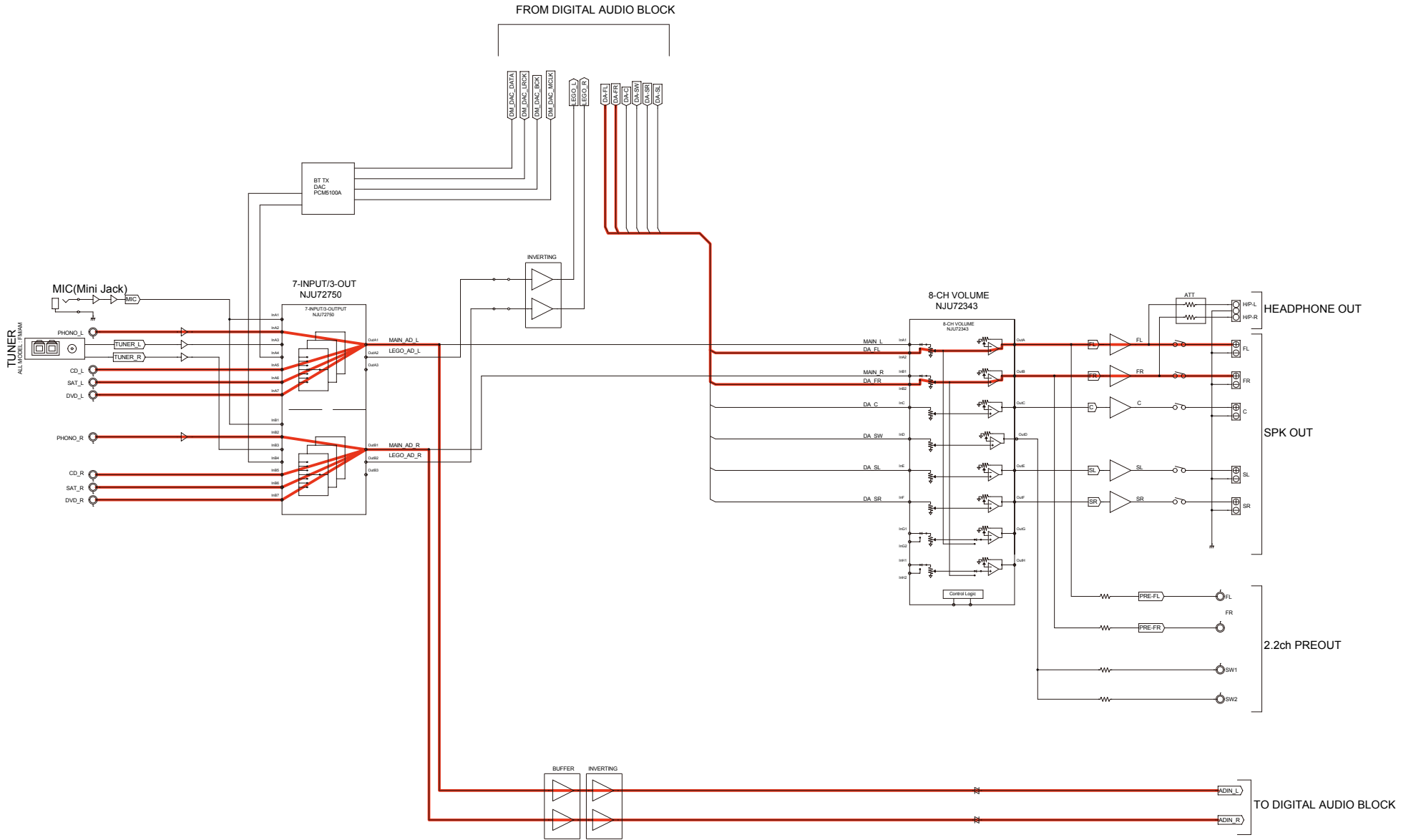

fig.V01

# NR1510 VIDEO DIAGRAM

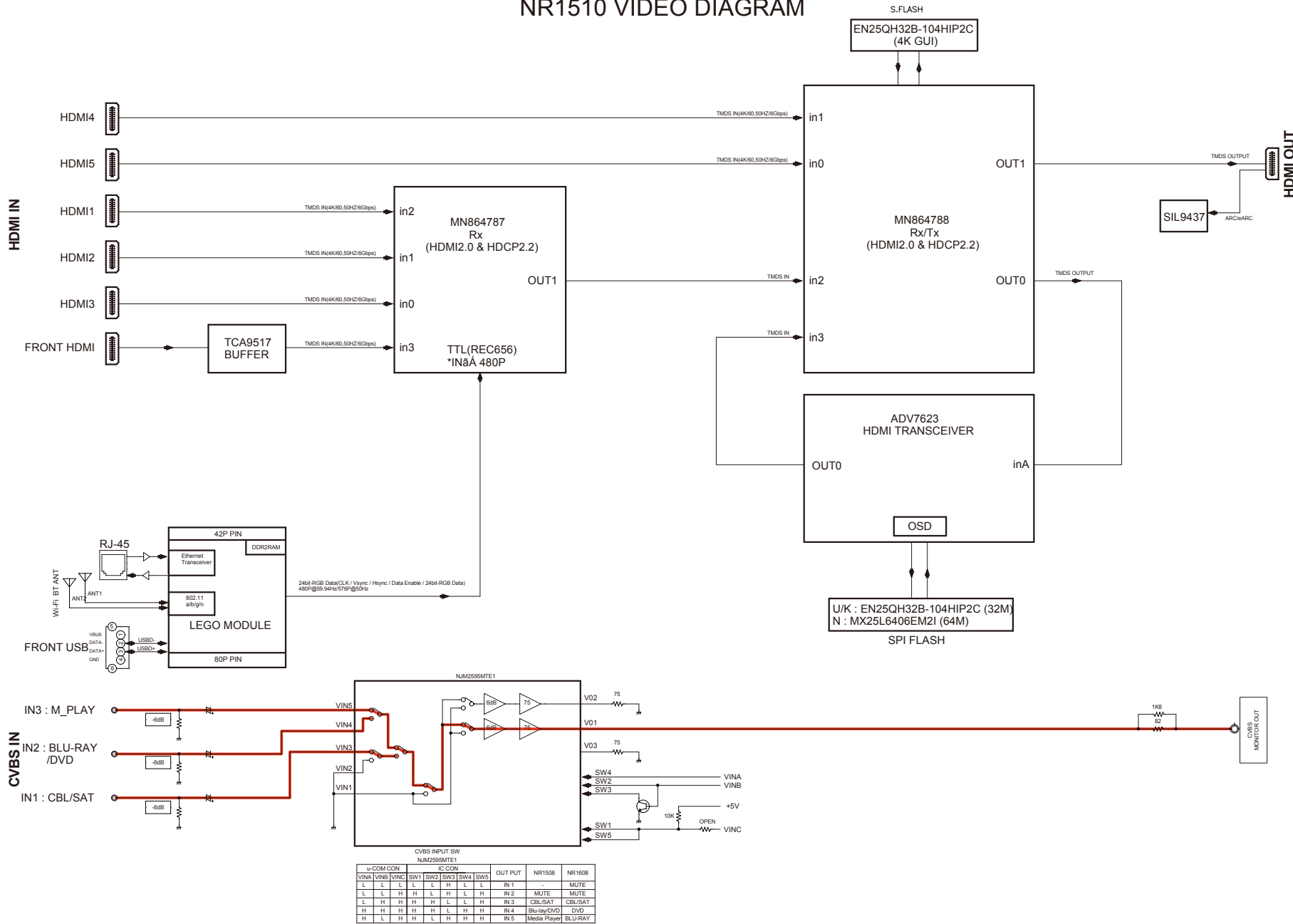

fig.V02

# NR1510 VIDEO DIAGRAM

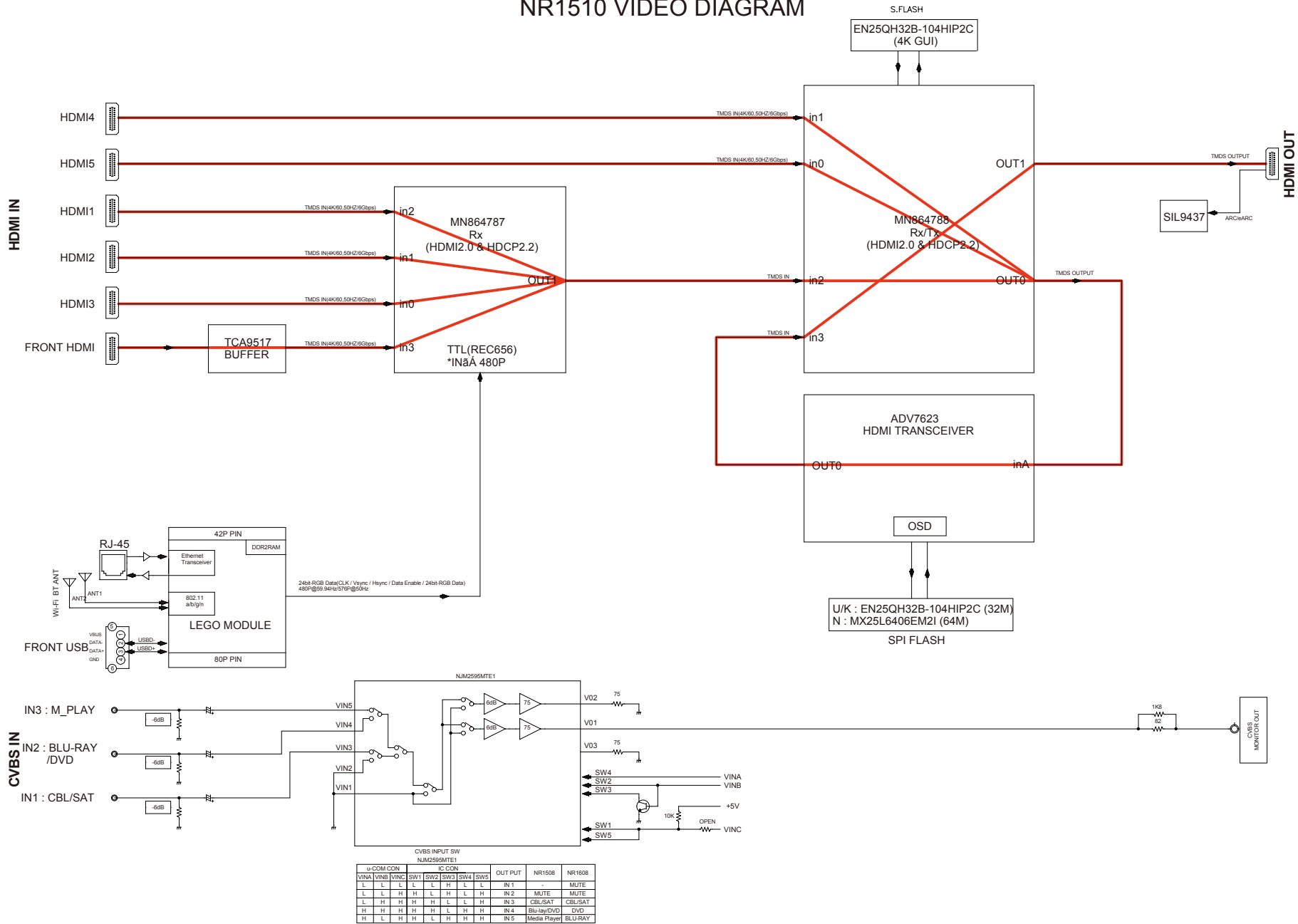



fig.V03

### NR1510 VIDEO DIAGRAM

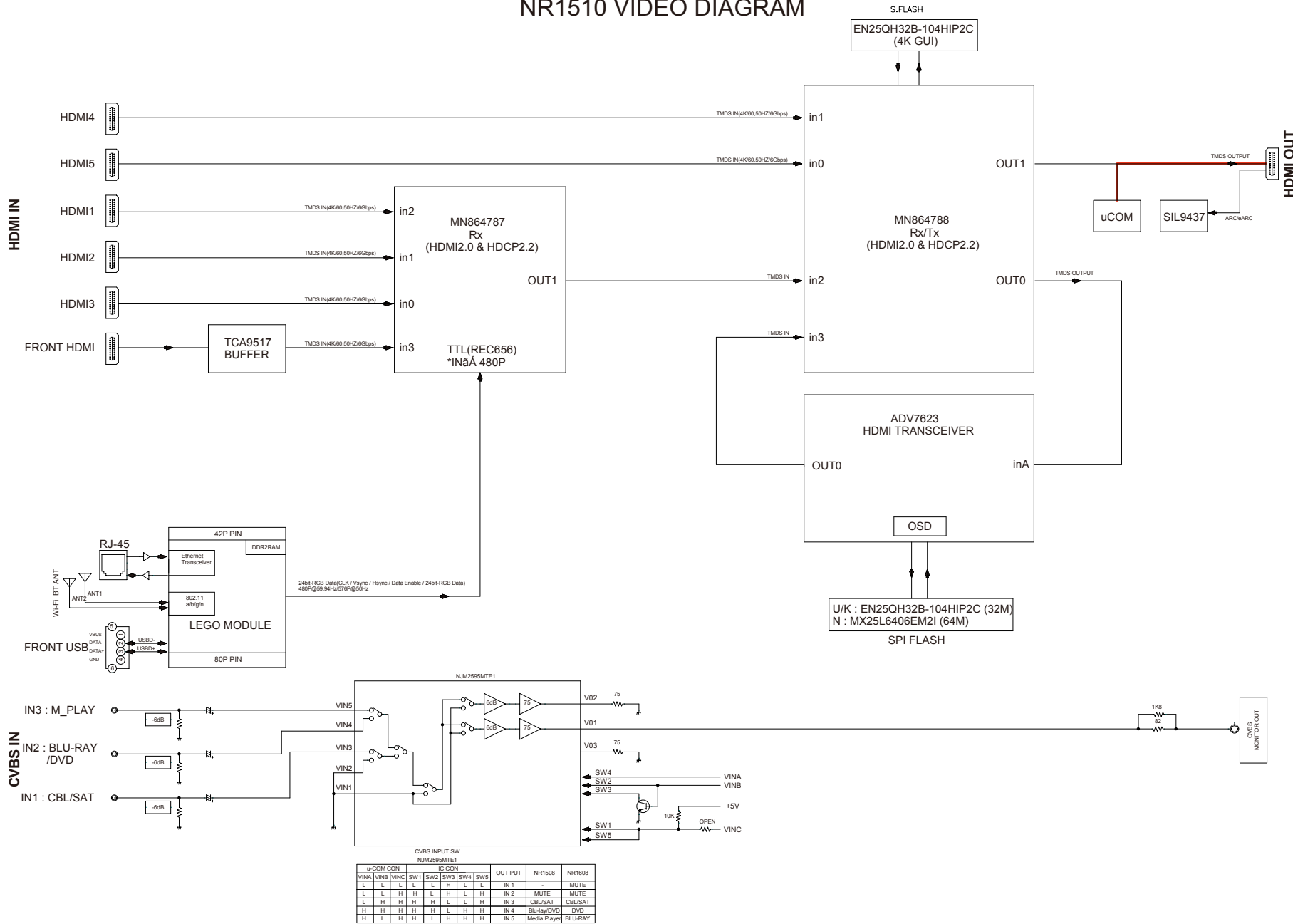
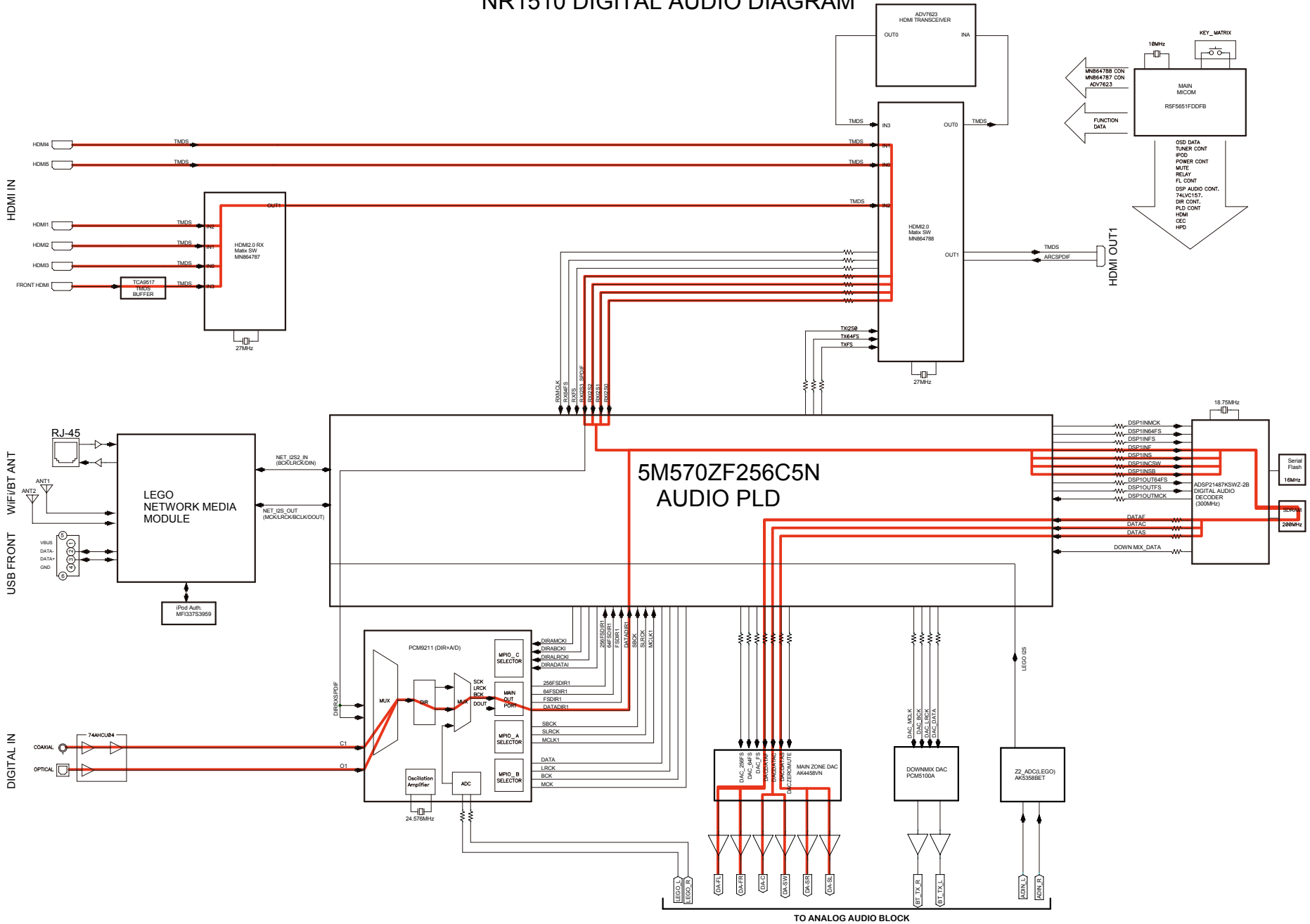

fig.V04a

# NR1510 DIGITAL AUDIO DIAGRAM



TO ANALOG AUDIO BLOCK

fig.V04b

# NR1510 ANALOG AUDIO DIAGRAM

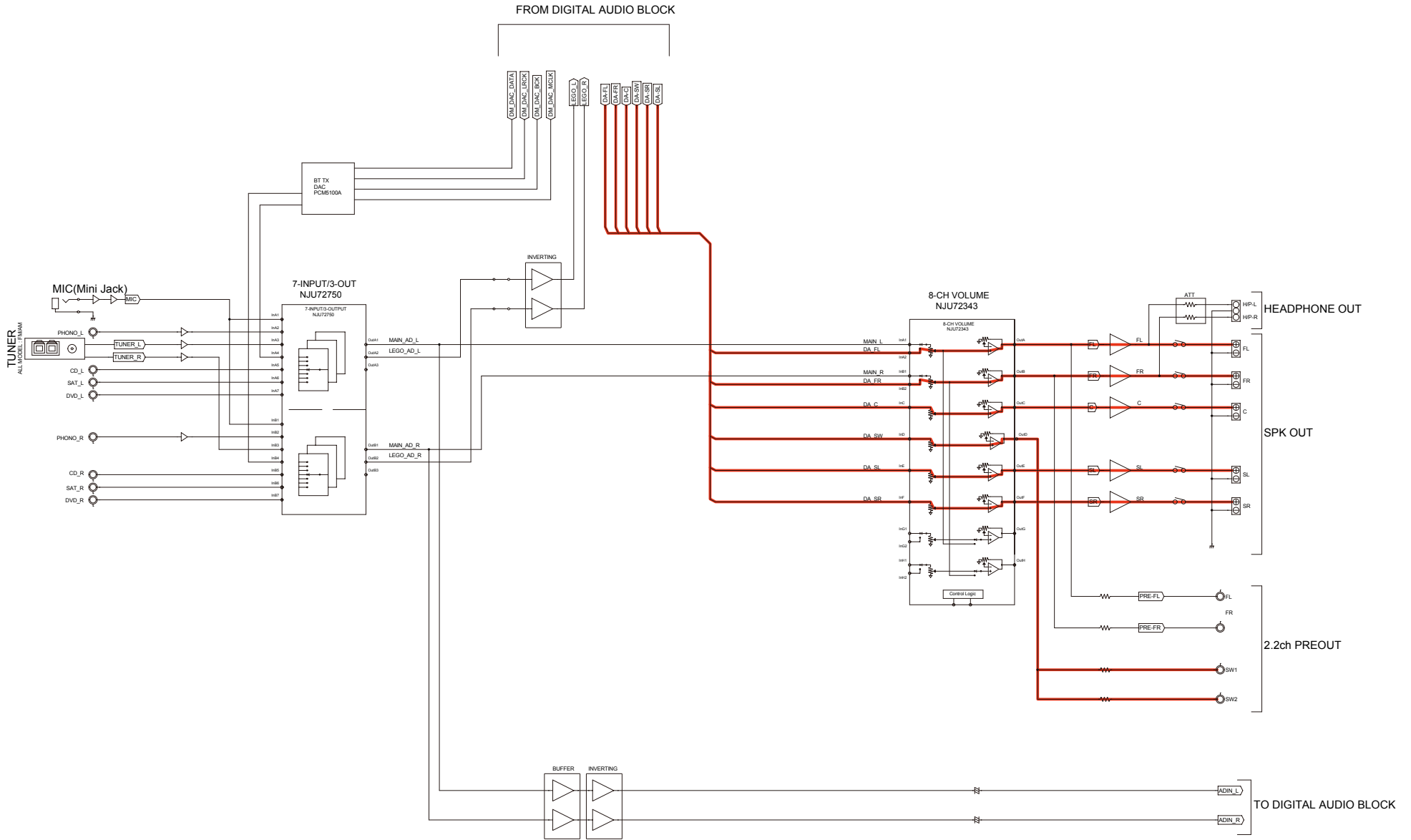
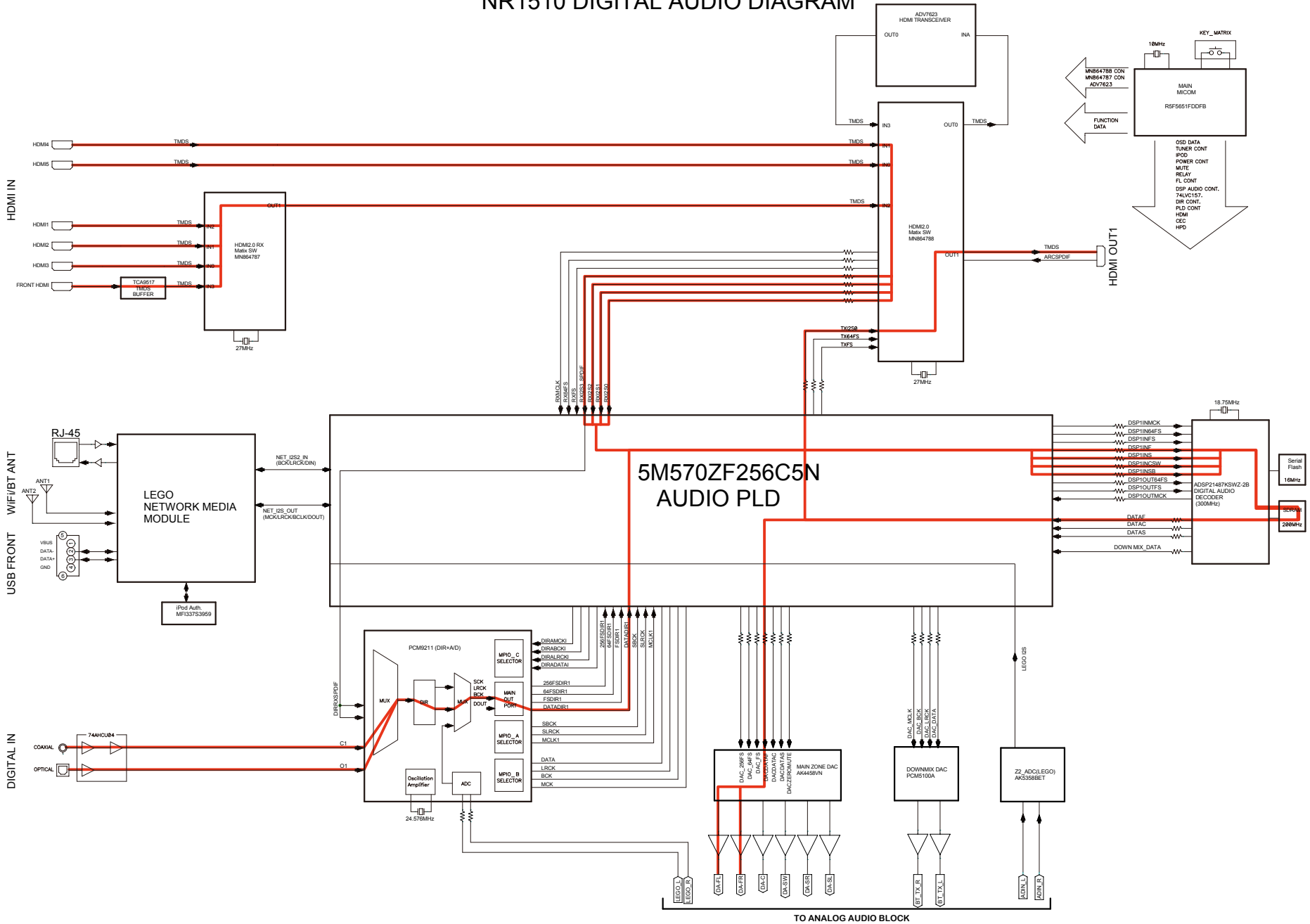

fig.V05

# NR1510 DIGITAL AUDIO DIAGRAM



TO ANALOG AUDIO BLOCK

fig.V06

### NR1510 VIDEO DIAGRAM

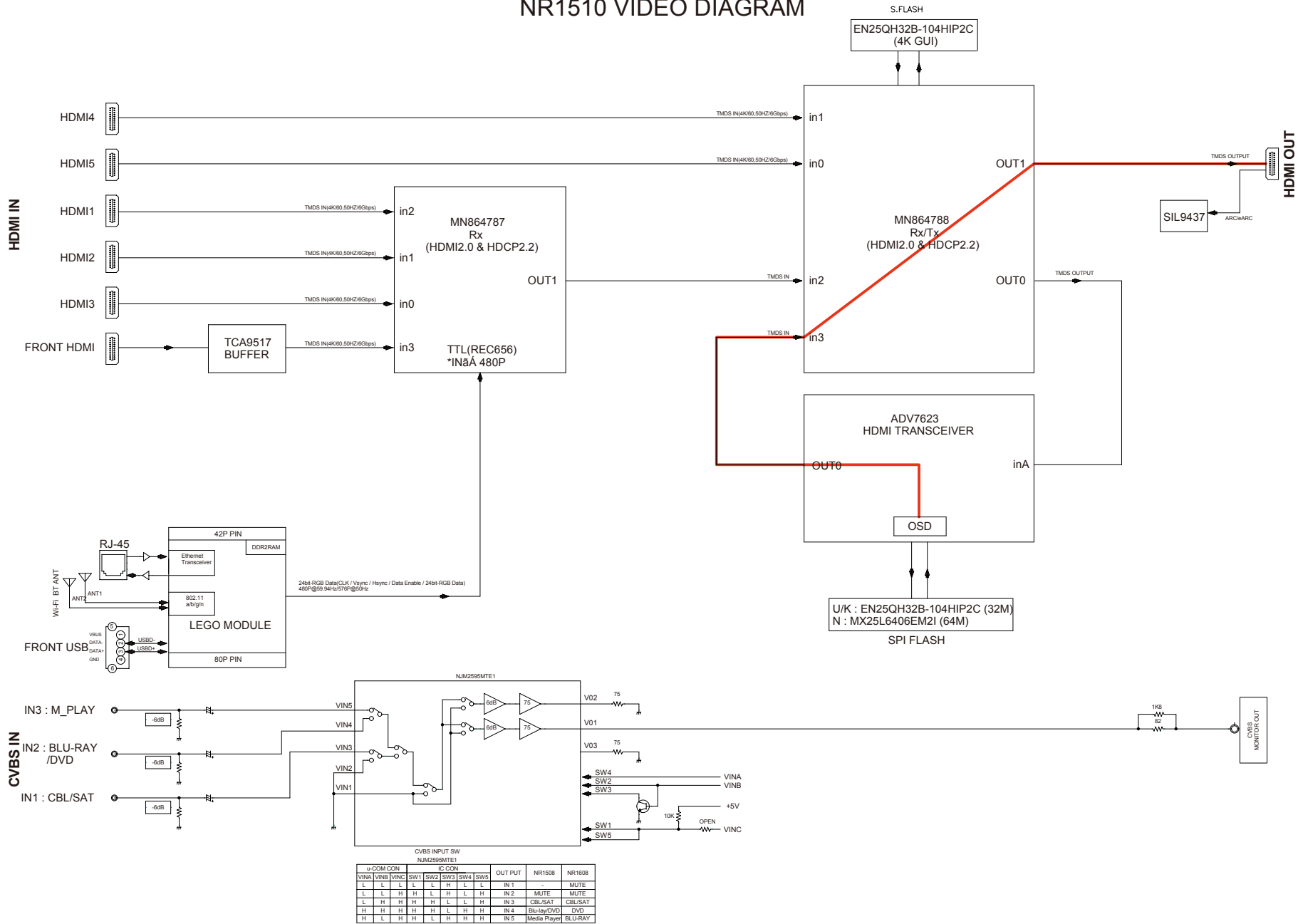

CVBS INPUT SW  
NIM2595MTE1

u-COM CON	IC CON					OUT PUT	NR1508	NR1608
VINA	VINB	VINC	SW1	SW2	SW3	SW4	SW5	
L	L	L	L	L	H	L	L	IN1
L	L	H	H	L	L	H	L	IN2
L	H	H	H	L	L	H	H	IN3
H	H	H	H	L	L	H	H	IN4
H	L	H	H	L	L	H	H	IN5

# JIG FOR SERVICING

Use the following jigs (extension cable kit) when repairing the PCBs.  
Order with your dealer for the jigs your dealer if necessary.

**CAUTION : Incorrect connections may cause malfunction.**

Connection of Jig for DIGITAL PCB

---Items to Be Prepared---

8U-110084S : EXTENSION UNIT KIT : 1 Set  
Insulation sheet (Not supplied) : 1 sheet  
Ground lead (Not supplied) : 2 pc

-Proceeding-

(1) Remove the screws.



(2) Remove the connector PCB.

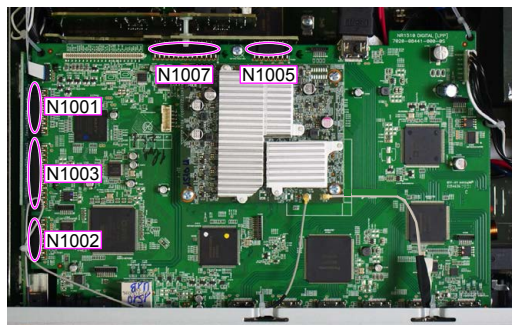

(3) Remove the DIGITAL PCB from the chassis and turn it over.  
Place an insulation sheet larger than the PCB underneath the DIGITAL PCB.  
※ Connect the earth of the PCB to the chassis using an earth wire, etc.

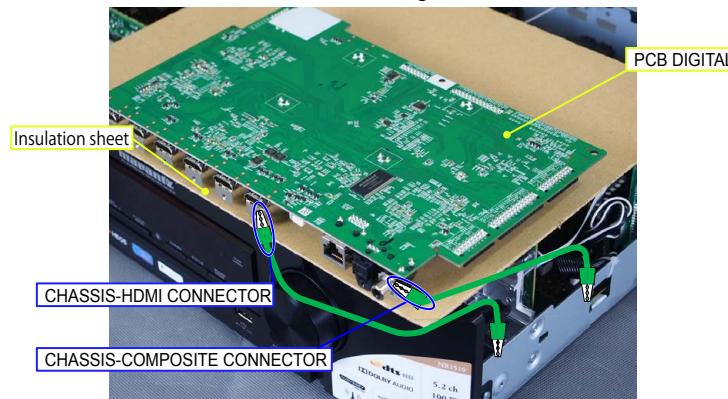

(4) Connect the expansion cables.

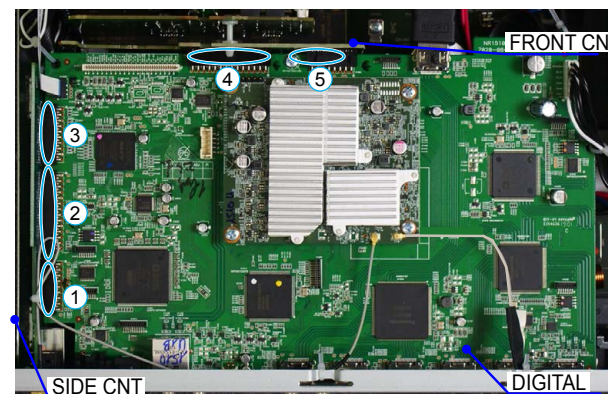

Board-to-Board Connections

No.	Pin	Ref. No.	PCB		Ref. No.	PCB
①	17pin	CP4603	SIDE CNT	↔	N1002	DIGITAL
②	27pin	CP4601	SIDE CNT	↔	N1003	DIGITAL
③	19pin	CP4600	SIDE CNT	↔	N1001	DIGITAL
④	27pin	CP4616	FRONT CNT	↔	N1007	DIGITAL
⑤	15pin	CP4613	FRONT CNT	↔	N1005	DIGITAL

Before Servicing  
This Unit

Electrical

Mechanical

Repair Information

Updating

## Adjusting Idling Current

**NOTE** : Adjusting the idling current when "ECO Mode" is set may damage the Power AMP.

### 1. Preparation

- (1) Prepare a DC voltmeter.
- (2) Place the unit under normal usage conditions, away from highly ventilated areas such as next to an air conditioning machine or electric fan.  
The set requires an ambient temperature of 15°C to 30°C and standard humidity.
- (3) Settings of This Unit
  - POWER (Power source switch)      STANDBY
  - SPEAKER (Speaker terminal)      No load  
(Do not connect equipment such as speakers or dummy resistors.)

### 2. Adjustment Procedure

- (1) Make sure that "ECO Mode" is off.
  - Press the "SETUP" button on the remote control to display the GUI menu.
  - Press the cursor button to select "General" → "ECO" → "Mode" → "Off".
- (2) Remove the top cover and turn **VR4800** (ALL Channel) of the AMP PCB counterclockwise(⤵) as far as possible.
- (3) Connect the DC Voltmeter to the test points.
 

FRONT-Lch	: TP4800	: VR4800
FRONT-Rch	: TP4802	: VR4801
CENTER ch	: TP4804	: VR4802
SURROUND-Lch	: TP4806	: VR4803
SURROUND-Rch	: TP4808	: VR4804
- (4) Connect the power cord to an outlet. Next, press the power button to turn on the power.
- (5) Set this unit as follows.
 

MASTER VOLUME	: "----" (⤵ min.)	: turn counterclockwise to the lowest position.
SPEAKER (Speaker terminal)	: No load	

(Do not connect equipment such as speakers or dummy resistors.)

MODE	: MCH STEREO
FUNCTION	: TUNER
- (6) Turn **VR4800** clockwise (⤴) and adjust the voltage of the test point to "**2.0mV ± 0.5mV DC**" within 2 minutes.
- (7) Check whether the voltage is within the range "**2.0mV +2mV/-1mV DC**" 10 minutes after adjustment.
- (8) Adjust the variable resistance of each channel using the same method.

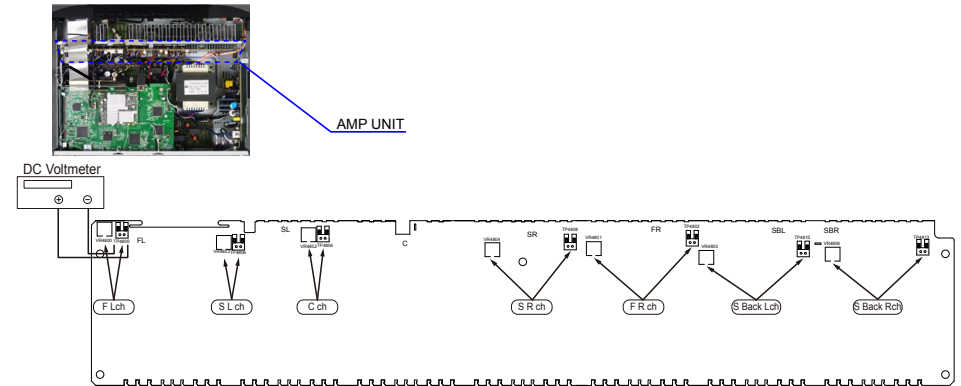

## PROCEDURE AFTER REPLACING THE PCB.

## PROCEDURE AFTER REPLACING THE U-COM, ETC.

## FIRMWARE UPDATE PROCEDURE

1. Items necessary for update
2. Update preparation with a USB flash drive
3. Update method when the DIGITAL PCB or network module is replaced (Using a USB flash drive)
4. Update Method for Service Region Settings
5. Normal Firmware Update Method from USB Flash Drive
6. Normal Firmware Update Method from OTA
7. About the error codes



## PROCEDURE AFTER REPLACING THE PCB.

The procedure after replacing the printed circuit boards is as follows.

(1) Change the resistor for setting the region.

Model Area	DIGITAL PCB	
	R1206	R1202
North America (U)	OPEN	0
Europe (N)	0	OPEN
China (K)	10k	10k

See the PCB below.

(2) Be sure to replace the software with the latest version.

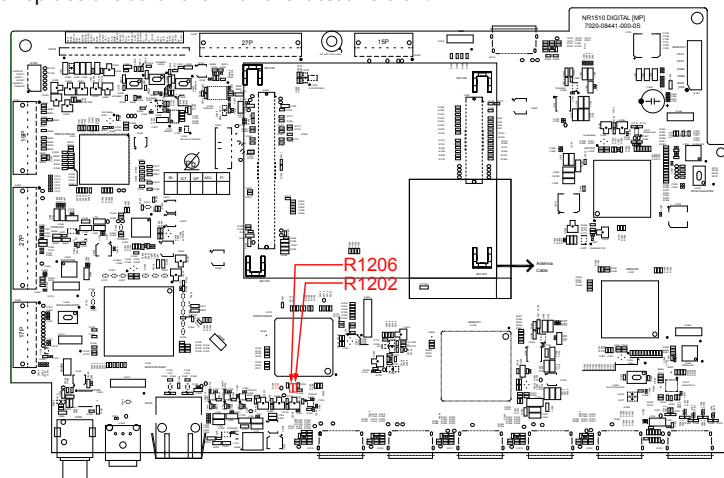

## PROCEDURE AFTER REPLACING THE U-COM, ETC.

The procedure after replacing the MCU (microprocessor), flash ROM, etc. is as follows.

Implement the update method when the DIGITAL PCB or network module is replaced.

PCB Name	Ref. No.	Description	Procedure after Replacement	Remark
DIGITAL	U1013	R5F5631FDDFB	B	SOFTWARE : Main
DIGITAL	U1023	MX25L1606EM2I-12G	B	SOFTWARE : DSP ROM
DIGITAL	U1029	MX25L3206EM2I 32 M MX25L6406EM2I 64M (N only)	B	SOFTWARE : GUI ROM
DIGITAL	U1041	5M570ZF256C5N	C	SOFTWARE : AUDIO PLD
DIGITAL	U1048	EN25QH32B-104HIP2C	B	SOFTWARE : PIMG ROM
MODULE	P6	NETWORK MODULE	D	SOFTWARE : Network

Procedure after Replacement

**A :** The software has been written. The software is not written at the time of replacement.

**B :** The software has been written. The software may need to be rewritten by version updates. Check the version.

**C :** The software has not been written. The software needs to be written after replacement.

See "[FIRMWARE UPDATE PROCEDURE](#)" for information on writing the software.

**D :** The software has been written. Be sure to rewrite with the latest software for your service region.

See "[3. Update method when the DIGITAL PCB or network module is replaced \(Using a USB flash drive\)](#)" for information on rewriting the software.

# FIRMWARE UPDATE PROCEDURE

## 1. Items necessary for update

Items necessary for update are as follows.

Update Type	Needed Part for Update	Requirement	Offered / not Offered		
			Standard Service Equipment Not offered by D&M	Purchase from D&M Article code	Download from SDI
Via USB	USB flash drive (USB 2.0 : Min 1GB) • We recommend a USB memory device that has an LED installed.	Formatting FAT16 or FAT 32	X	-	"Table 1" or "Table 2"
Via OTA	Internet Connection by Broadband Circuit	-	X	-	-
	Modem	-	X	-	-
	Router	-	X	-	-
	Ethernet cable (CAT-5 or greater is recommended)	-	X	-	-

**Table 1**

Update download file when the DIGITAL PCB or network module is replaced

Model Name	Model Area	Download from SDI
NR1510	ALL	avr_40.prod.update.factory.xxxx.zip

**Table 2**

Update download file when the firmware is updated (Two files, "HW component" and "LEGO component")

Model Name	Model Area	Download from SDI	
		For HW component	For LEGO component
NR1510 U	North America (U)	Product ID : 100100740100	DPMS_NR1510U_LEGO_xxxx.zip
NR1510 N	Europe (N)	Product ID : 100100740200	DPMS_NR1510N_LEGO_xxxx.zip
NR1510 K	China (K)	Product ID : 100100740500	DPMS_NR1510K_LEGO_xxxx.zip

Before Servicing  
This Unit

Electrical

Mechanical

Repair Information

Updating

## 2. Update preparation with a USB flash drive

You can update the firmware by downloading the latest version with USB flash drive.

### 2.1. Connecting to the USB flash drive

(1) Preparation

- Windows PC
- USB flash drive format : Prepare a USB flash drive formatted in FAT16 or FAT32.  
※We recommend a USB flash drive that has an LED installed.

NOTE :

- Use a memory that supports USB2.0.
- Do not run the USB flash drive through a hub.
- Do not connect a computer to the USB port of this unit using a USB cable.
- Do not use an extension cable when connecting the USB flash drive.
- Save the update file on a blank USB flash drive for use.
- If a USB flash drive cannot be updated, replace it with a different USB flash drive and perform the update again.

### 2.2. Unzipping the Downloaded File

Unzip the downloaded file on your computer.

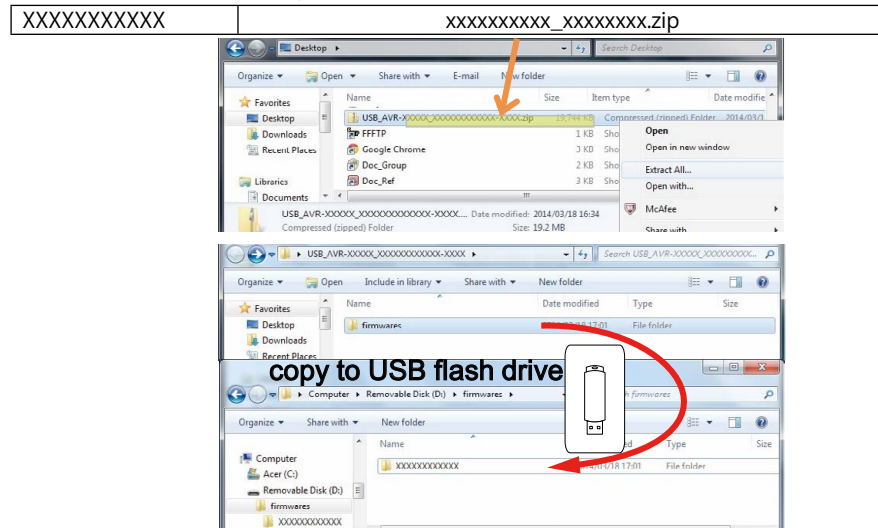

There are folders or files after unzipping.

Copy these folders or files onto the USB flash drive.

The folders or files must be placed in the root directory of the USB flash drive.

### 3. Update method when the DIGITAL PCB or network module is replaced (Using a USB flash drive)

#### 3.1. File structure on USB flash drive

DIGITAL PCB or network module is replaced onto the USB flash drive in the following structure.

After unzipping the files, store them in the root of the same USB flash drive.

Model Area	Download from SDI
ALL	avr_40.prod.update.factory.xxxx.zip

USB flash drive root

- + avr\_40.prod.update.factory
- + xxxxxxx.ota-download
- + heos\_40.prod.update.factory

xxxxxx : Model name  
zz : Region

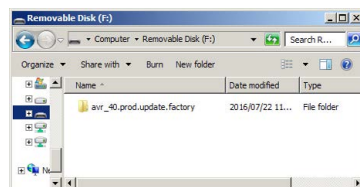

#### 3.2. Start the update.

NOTE :

- Remove the LAN cable from this unit when updating. (Do not connect to a wired or wireless network.)
- The GUI menu setting details and image quality adjustment setting details are initialized when Firmware Factory Restore is performed. Therefore, take a note of the setting details beforehand and reconfigure the settings after update.
- Do not remove the USB flash drive until updating is completed.
- Do not turn off the power until updating is completed.
- It takes a maximum of approximately 25 minutes for update to complete.

Once an update is started, normal operations cannot be performed until it is completed.

- (1) Press the power button to turn on the power.
- (2) Wait for this unit to start up.
- (3) Set the input source to HEOS Music. Check that the display is as shown below.

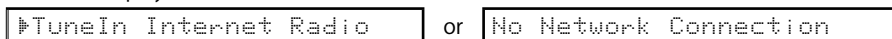

Content of the display is scrolled.

- (4) Insert the USB flash drive into the USB port.

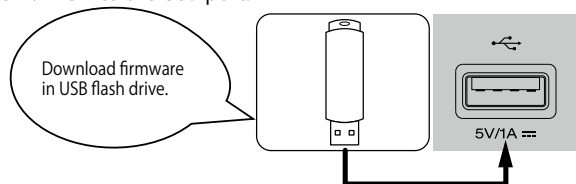

- (5) USB Update starts automatically. The Standby LED lights red.

Display during USB update

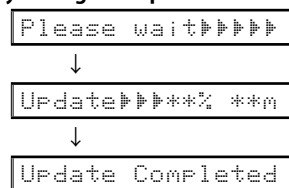

It takes a maximum of approximately 25 minutes for update to complete.

- (6) The unit restarts when update is complete.
  - ※When update is complete, the folder name on the USB flash drive changes to "avr\_40.prod.update.factory.done". To use the files again, delete the ".done" part.
- (7) Execute Firmware Factory Restore. While holding down buttons "STATUS" and "PURE DIRECT" simultaneously, press the power button to turn on the power.

Display during Firmware Factory Restore

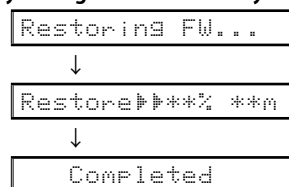

It takes approximately 15 minutes for Firmware Factory Restore to complete.

- (8) Execute Service Region Settings. See "4. Update Method for Service Region Settings"
- (9) Check that the version is the specified version. See "1. Version Display Mode"
- (10) If necessary, use OTA or the USB flash drive to update the firmware to the newest version.
  - ※We recommend using the firmware update method using OTA. See "5. Normal Firmware Update Method from USB Flash Drive" or "6. Normal Firmware Update Method from OTA"

## 4. Update Method for Service Region Settings

Copy the Service Region Settings from the USB flash drive to this unit.

### 4.1. Creating a Service Region Settings file

(1) Click [Start button] - [Accessories] - [notepad] on the PC to launch the notepad.

(2) Enter "TEXT".

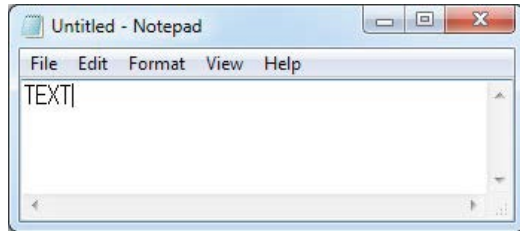

(3) Click "File", and then click "Save As...".

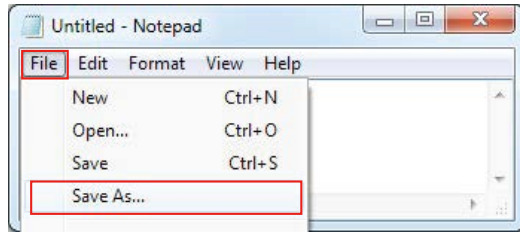

(4) Enter the file name and click the Save button.

NOTE : Enter the file name in double quotation marks. (The file extension is not required.)

Service Region	File name
North America	"denon-config-locale-set-1"
Europe	"denon-config-locale-set-2"
Japan	"denon-config-locale-set-3"
Australia	"denon-config-locale-set-4"
Korea	"denon-config-locale-set-5"
China	"denon-config-locale-set-6"
Israel	"denon-config-locale-set-7"

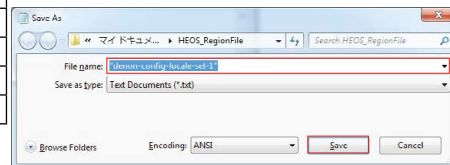

(5) Copy the files created on the USB flash drive.

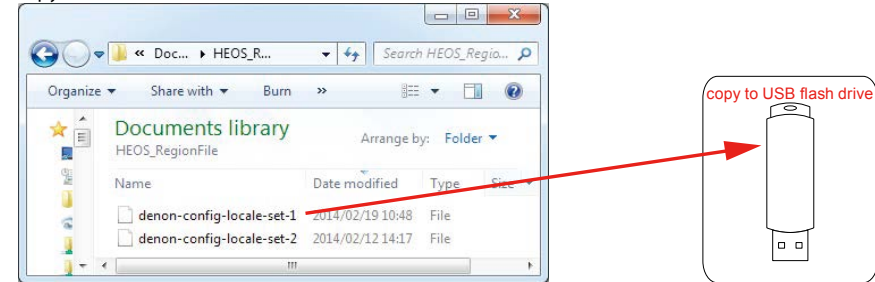

### 4.2. Starting Service Region Settings

NOTE :

- Remove the LAN cable from this unit when updating. (Do not connect to a wired or wireless network.)
- We recommend a USB memory device that has an LED installed.

- (1) Press the power button to turn on the power.
- (2) Wait for this unit to start up.
- (3) Set the input source to HEOS Music.  
Check that the display is as shown below.

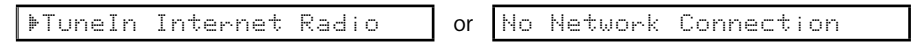

Content of the display is scrolled.

(4) Insert the USB flash drive into the USB port.

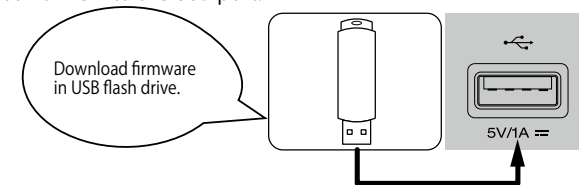

- (5) Wait for at least 10 seconds before removing the USB flash drive. (If the USB flash drive has an LED, this LED will be flashing. Remove the USB flash drive when the LED stops flashing.)

## 5. Normal Firmware Update Method from USB Flash Drive

### 5.1. File structure on USB flash drive

Copy the normal update files onto the USB flash drive in the following structure.

After unzipping the HW component USB update files for the target model and LEGO USB update files, store them in the root of the same USB flash drive.

Model Area	Download from SDI	
	For HW component	For LEGO component
North America (U)	DPMS_NR1510U_LEGO_xxxx.zip Product ID : 100100740100	heos_40.prod_x.xxx.xx.zip
Europe (N)	DPMS_NR1510N_LEGO_xxxx.zip Product ID : 100100740200	
China (K)	DPMS_NR1510K_LEGO_xxxx.zip Product ID : 100100740500	

USB flash drive root

- + NRxxxx\_xxxx.update.auto
- + heos\_40.prod.update.x-xxx-xx

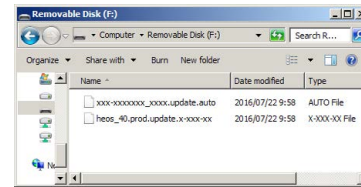

### 5.2. Start normal update

NOTE :

- Remove the LAN cable from this unit when updating.  
(Do not connect to a wired or wireless network.)
- Do not remove the USB flash drive until updating is completed.
- Do not turn off the power until updating is completed.
- It takes a maximum of approximately 25 minutes for update to complete.

Once an update is started, normal operations cannot be performed until it is completed.

The GUI menu settings and image adjustment settings of this unit may be initialized.

Note down the settings before updating, and set them again after updating.

- (1) Press the power button to turn on the power.
- (2) Wait for this unit to start up.
- (3) Set the input source to HEOS Music.  
Check that the display is as shown below.

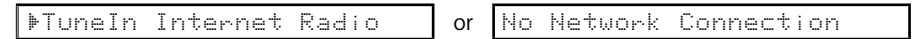

Content of the display is scrolled.

- (4) Insert the USB flash drive into the USB port.

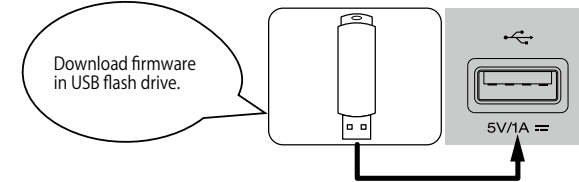

- (5) USB Update starts automatically.  
The Standby LED lights red.

Display during USB update

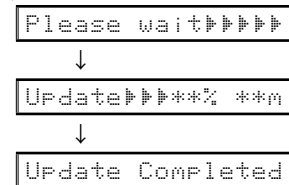

It takes a maximum of approximately 25 minutes for update to complete.

- (6) The unit restarts when update is complete.
- (7) After updating the firmware, check the version.  
See "1. Version Display Mode"

## 6. Normal Firmware Update Method from OTA

Download the latest firmware from our website and update the firmware.

### ---Cautions on Firmware Update---

- For the update procedure, a proper broadband Internet connection environment and settings are required.
  - Do not turn off the power until updating is completed.
  - It takes a maximum of approximately 25 minutes for update to complete.
- Once an update is started, normal operations cannot be performed until it is completed. The GUI menu settings and image adjustment settings of this unit may be initialized. Note down the settings before updating, and set them again after updating.

### 6.1. Network Connection

- (1) System Requirements
  - Internet Connection by Broadband Circuit
  - Modem
  - Router
  - Ethernet cable (CAT-5 or greater is recommended)
- (2) Setting

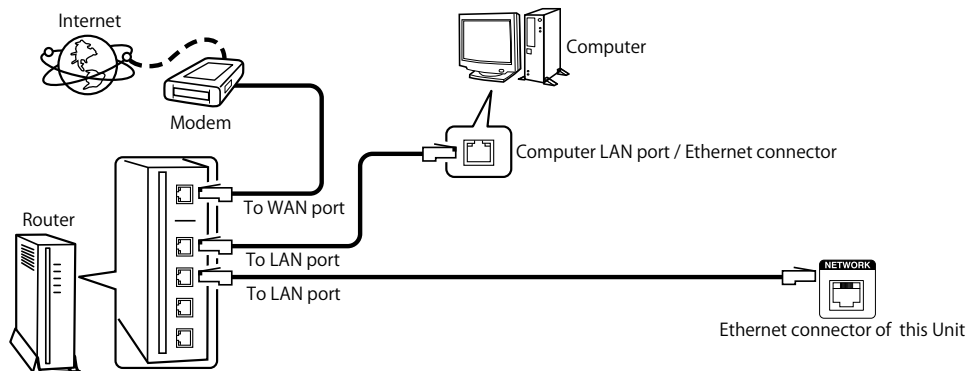

### 6.2. Check and update the firmware

Check if there is a firmware update available. It is also possible to check approximately how long the update will take.

- (1) Press the "SETUP" button on the remote control to display the GUI menu.
- (2) Press the cursor button to select "General" → "Firmware" → "Check for Update".
- (3) Check update
  - If the firmware version is anything other than the latest version, select "Update Now" to update the firmware.
  - "No update required. Latest version installed." is displayed when the firmware version is up to date.
- (4) OTA Update starts automatically.  
The Standby LED lights red.

#### Display during OTA update

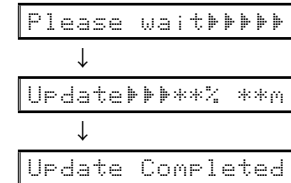

- It takes a maximum of approximately 25 minutes for update to complete.
- (5) The unit restarts when update is complete.
  - (6) After updating the firmware, check the version.  
See "1. Version Display Mode"

## 7. About the error codes

See the table below for details on error codes and solutions when updating the firmware. Error codes are displayed in 4 digits, **YYXX**(**YY** : DeviceID, **XX** : ErrorCode).

### Display

Update▶▶▶▶\*\*% \*\*n



Update Error**YYXX** Update Error**YYXX** (**YY** : DeviceID, **XX** : ErrorCode)

↓ ↑ The display is alternately displayed.

Please check you

**Content of the display is scrolled.**

### Remedies

Error Code (YYXX) (DeviceID/ErrorCode)	Remedies
000A	"Connection failed. Please check your network, then try again."
0009	"Update failed. Please check your network, then try again."
0009	"Upgrade failed. Please check your network, then try again."
YY00 YY01 YY02 YY03 YY04 YY07	"Please check your network, unplug and reconnect the power cord, and try again."
YY00 YY01 YY02 YY03 YY04 YY07	"Please unplug and reconnect the power cord, and try again."
0005	"Incompatible update file found on the USB device. Please check the file."
0006	"Update file is corrupted. Please check the file."
000B	"Please contact customer service in your area." ※ Check the power supply and communication lines of each device.

### Device ID table

Device ID (YY)	Device Name
00	General
01	Main CPU
0E	Main FBL (No used)
11	DSP1 or DSP
12	DSP2 ※ Except : NR1510/NR1710/SR5014
13	DSP3 ※ Except : NR1510/NR1710/SR5014
19	DSP4 ※ Except : NR1510/NR1710/SR5014
15	Audio PLD
22	Video PLD ※ Except : NR1510/NR1710
2A	GUI
2B	PIMG ※ ONLY : NR1510/NR1710/SR5014
33	LEGO

### Error Code table

Type code (XX)	Description
00	Logical error
01	Error during erasing
02	Error during writing
03	Error during verifying
04	No access for the component
05	Package mismatched. Product ID, package version un-matched of the package manifest
06	Unpack dis-available of component package file
07	Time out
08	Latest firmware has already installed.
09	Error during download
0A	Error connection
0E	Hardware Error

### ---Checking the Firmware Version After the Update---

After updating the firmware, check the version.

See "1. Version Display Mode"



**[www.marantz.com](http://www.marantz.com)**

You can find your nearest authorized distributor or dealer on our website.

**marantz**<sup>®</sup> is a registered trademark.