

# Ultra-Bright Remote Monitor

## User Guide

### Introduction

The Ultra-Bright Remote Monitor uses the DJI™ O3 image transmission technology to establish a wireless connection to the RONIN™ 4D Video Transmitter mounted on the Ronin 4D. Users can monitor the camera live view and control the camera via the monitor. The expansion plate is also supported to expand input of DC and CAN and output of HDMI and SDI. Hand grips can be mounted to the remote monitor cage on the monitor for remote control.

### Diagram

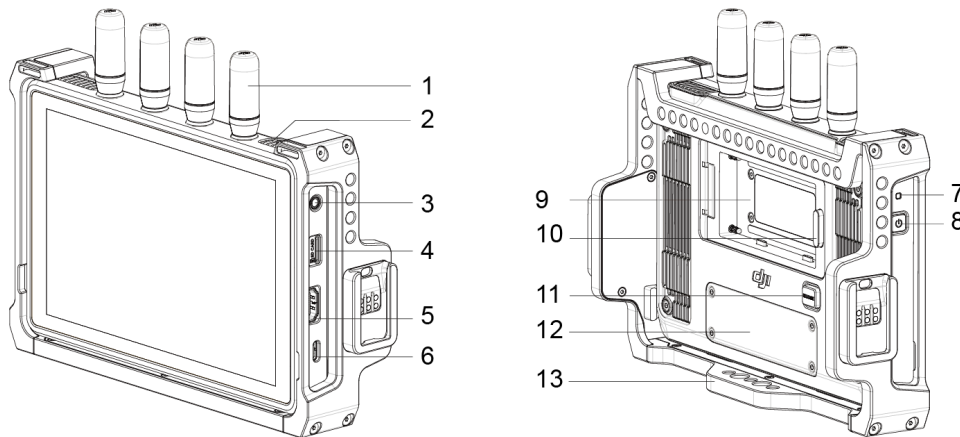

1. Detachable Antennas
2. Ventilation Holes
3. 3.5mm Headphone Jack
4. microSD Card Slot

If a microSD card is mounted, the recorded files can be stored in the microSD card. The max capacity is 512 GB.

5. HDMI Port

To output the live view to other display devices.

6. USB-C Port

Connect to the DJI Assistant 2 (Ronin Series) software using a USB-C cable to activate and update the device and export data.

7. Power Indicator

The indicator will be solid on after powered on and it will be off when powered off.

8. Power Button

Press once to power on the device. Press and hold to power it off.

## 9. Battery Slot

To mount the battery for power supply.

## 10. Battery Release Button 1

## 11. Battery Release Button 2

## 12. Expansion Plate Port Cover

The expansion plate port under the cover is used to mount the remote monitor expansion plate to expand input of DC and CAN and output of HDMI and SDI.

## 13. Cage

There are 1/4" screw holes, 1/8" screw holes, and hand grips ports on the cage to mount the corresponding accessories.

## Mounting and Removing the Battery

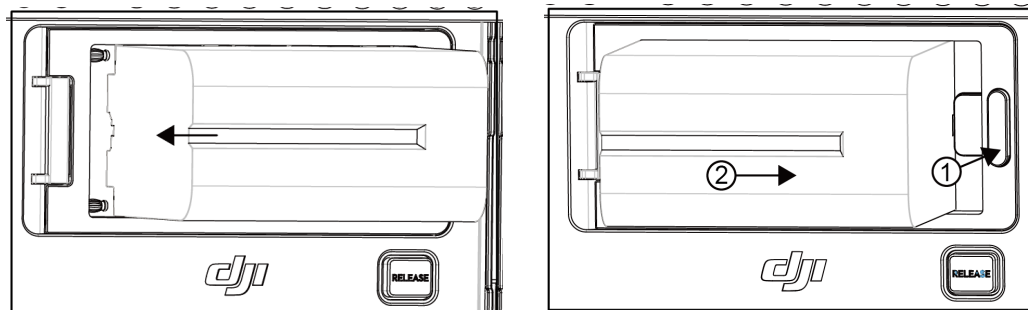

## Activation

The monitor requires activation before using for the first time. Power on the monitor and connect it to the computer. Launch DJI Assistant 2 (Ronin Series), click the corresponding icon of the device and follow the instructions to activate the device.

## Linking

Linking between the monitor and the Ronin 4D video transmitter is required before use. Make sure that the video transmitter is mounted to the Ronin 4D before linking. The monitor has two work mode: control mode and audience mode. The linking method varies depending on the work mode.

### Control Mode

1. Power on the monitor. Tap  to enter System Settings and then Connection Settings. Tap Device Pairing under Control Mode, set the monitor in use as RC A or RC B, and tap Connect to enter linking status.
2. In Image Transmission Settings in the Ronin 4D ultra-bright main monitor, tap Pairing to enter linking status.
3. The ultra-bright remote monitor will display connected status after linking is successful. The

corresponding device A or device B status on the Ronin 4D ultra-bright main monitor will display connected.

### Audience Mode

1. Enable Broadcast Mode in Image Transmission Settings in the Ronin 4D ultra-bright main monitor.
2. Power on the ultra-bright remote monitor. Tap **...** to enter System Settings and then Connection Settings. Tap Audience Mode and the monitor will automatically search for the devices nearby. Tap the device you want to monitor and its live view will be displayed. Tap the corresponding buttons on the right of the live view to refresh display or switch between devices.

## Touchscreen Interface



The interface varies for control mode and audience mode. The following description is the interface introduction for control mode. In audience mode, control related operations such as shooting parameters adjustment, force mobile, and LUT switch cannot be performed.

1. Battery Level and External Power Voltage
2. Remote Control Devices  
To display the connected remote control devices such as three-channel follow focus, hand grips, and master wheels.
3. HDMI Input Devices
4. Video Downlink Signal Strength and Bitrate
5. Shooting Parameters\*  
Includes white balance, ND, angle of aperture/shutter speed (one of the two displayed by following the setting in the Ronin 4D), aperture and EI. Tap to adjust the corresponding parameter.
6. Screen Lock

7. System Settings
    - Connection Settings: Switch between control mode and audience mode and link devices.
    - General Settings: Set the screen brightness, whether to display the front sight, ratio and transparency of the safety frame.
    - About, Help: View information such as the version and SN. Get support from video tutorials.
  8. Audio Gain
  9. Monitor Volume
    - Listen to the audio only if an audio receiving device is connected to the 3.5mm headphone jack.
  10. Record Button and Timecode
    - Tap the button to start or stop shooting. Only video recording is supported.
  11. LUT
  12. Playback
    - Tap to preview the pictures and videos stored in the Ronin 4D.
  13. Exposure Aid/Focus Aid\*
    - False Color: When enabled, the live view will be displayed in false color.
    - Waveform: When enabled, the bottom of the screen will display the waveform of the exposure values.
    - Zebra: When enabled, the overexposed areas in the image will be displayed in zebra crossing. Adjust the level proportion of the zebra display using the slider under the option.
    - Peaking: Enable the peaking display and set the display color of the color peak or the acutance percentage of the acutance peak.
    - Depth Waveform: When enabled, the right of the screen will display the depth map of the live view in its top view.
    - The settings mentioned above are same with the ones for the Ronin 4D ultra-bright main monitor. Refer to the Ronin 4D User Manual for details.
  14. Focus Ruler
  15. Safety Frame
    - Users can set the ratio of the safety frame and the transparency of the area out of the frame.
- \* To adjust the shooting parameters, start/stop shooting, configure exposure aid/focus aid, make sure that remote control is enabled in the Ronin 4D ultra-bright main monitor.

## Firmware Update

Update the monitor using the DJI Assistant 2 (Ronin Series) software.

1. Power on the device. Connect the device to the computer using a USB-C cable.
2. Launch DJI Assistant 2 (Ronin Series) and log in with a DJI account.
3. Select the device and click Firmware Update on the left side of the screen.
4. Select the firmware version.
5. The firmware will be downloaded and updated automatically.
6. The device will restart automatically after the firmware update is complete.

## Specifications

Model	RXD2
Weight	Remote monitor cage included: 768 g Remote monitor cage excluded: 496 g
Dimensions	Remote monitor cage included: 214×52×166 mm (L×W×H) Remote monitor cage excluded: 184×26×158 mm (L×W×H)
Screen Resolution	1920×1200
Screen Brightness	>1000 cd/m <sup>2</sup>
Video Transmission System	O3 (OcuSync 3.0)
Live View Quality	1080p@60fps
Max Communication Bandwidth	40 MHz
Video Coding Format	H.264
Max Bitrate	50 Mbps
Latency	68 ms (1080p@60fps), 100 ms (1080p@24fps)
Operating Frequency**	2.4000-2.4835 GHz, 5.150-5.250 GHz, 5.250-5.350 GHz, 5.470-5.725 GHz, 5.725-5.85 GHz
Transmitter Power (EIRP)	2.4 GHz: <33 dBm (FCC), <20 dBm (CE/SRRC/MIC) 5.1 GHz & 5.2 GHz & 5.5 GHz: <26 dBm (FCC), <23 dBm (CE/SRRC/MIC) 5.8 GHz: <33 dBm (FCC), <14 dBm (CE), <23 dBm (SRRC)
Compatible Battery	DJI WB37 Intelligent Battery
Operating Temperature	-10° to 40° C (14° to 104° F)

\*\* Local regulations in some countries prohibit the use of the 5.8 GHz and 5.2 GHz frequencies. In some countries, the 5.2 GHz frequency band is only allowed for indoor use.

## **Compliance Information**

### **FCC Compliance Notice**

Supplier's Declaration of Conformity

Product name: DJI Ultra-Bright Remote Monitor

Model Number: RXD2

Responsible Party: DJI Technology, Inc.

Responsible Party Address: 201 S. Victory Blvd., Burbank, CA 91502

Website: [www.dji.com](http://www.dji.com)

We, DJI Technology, Inc., being the responsible party, declares that the above mentioned model was tested to demonstrate complying with all applicable FCC rules and regulations.

This device complies with Part 15 of the FCC Rules. Operation is subject to the following two conditions: (1) This device may not cause harmful interference, and (2) This device must accept any interference received, including interference that may cause undesired operation.

Any changes or modifications not expressly approved by the party responsible for compliance could void the user's authority to operate the equipment.

This equipment has been tested and found to comply with the limits for a Class B digital device, pursuant to part 15 of the FCC Rules. These limits are designed to provide reasonable protection against harmful interference in a residential installation. This equipment generates, uses and can radiate radio frequency energy and, if not installed and used in accordance with the instructions, may cause harmful interference to radio communications. However, there is no guarantee that interference will not occur in a particular installation. If this equipment does cause harmful interference to radio or television reception, which can be determined by turning the equipment off and on, the user is encouraged to try to correct the interference by one or more of the following measures:

- Reorient or relocate the receiving antenna.
- Increase the separation between the equipment and receiver.
- Connect the equipment into an outlet on a circuit different from that to which the receiver is connected.
- Consult the dealer or an experienced radio/TV technician for help.

### **RF Exposure Information**

This equipment complies with FCC radiation exposure limits set forth for an uncontrolled environment. End user must follow the specific operating instructions for satisfying RF exposure compliance. This transmitter must not be co-located or operating in conjunction with any other antenna or transmitter.

The portable device is designed to meet the requirements for exposure to radio waves established by the Federal Communications Commission (USA). These requirements set a SAR limit of 1.6 W/kg averaged over one gram of tissue. The highest SAR value reported under this standard during product certification for use when properly worn on the body.

### ISED Compliance Notice

This device contains licence-exempt transmitter(s)/receiver(s) that comply with Innovation, Science and Economic Development Canada's licence-exempt RSS(s). Operation is subject to the following two conditions: (1) This device may not cause interference. (2) This device must accept any interference, including interference that may cause undesired operation of the device.

L'émetteur/récepteur exempt de licence contenu dans le présent appareil est conforme aux CNR d'Innovation, Sciences et Développement économique Canada applicables aux appareils radio exempts de licence. L'exploitation est autorisée aux deux conditions suivantes : (1) L'appareil ne doit pas produire de brouillage; (2) L'appareil doit accepter tout brouillage radioélectrique subi, même si le brouillage est susceptible d'en compromettre le fonctionnement.

This equipment complies with ISED radiation exposure limits set forth for an uncontrolled environment. End user must follow the specific operating instructions for satisfying RF exposure compliance. This transmitter must not be co-located or operating in conjunction with any other antenna or transmitter. The portable device is designed to meet the requirements for exposure to radio waves established by the ISED.

No operation is permitted for the frequency "5600-5650MHz"

Aucune opération n'est autorisée pour la fréquence « 5600-5650MHz »

The device for the band 5150-5350 MHz are only for indoor use.

Les appareils de la bande 5150-5350 mhz ne sont conçus que pour une utilisation en intérieur.

These requirements set a SAR limit of 1.6 W/kg averaged over one gram of tissue. The highest SAR value reported under this standard during product certification for use when properly worn on the body.

Cet équipement est conforme aux limites d'exposition aux rayonnements ISED établies pour un environnement non contrôlé. L'utilisateur final doit suivre les instructions spécifiques pour satisfaire les normes. Cet émetteur ne doit pas être co-implanté ou fonctionner en conjonction avec toute autre antenne ou transmetteur. Le dispositif portatif est conçu pour répondre aux exigences d'exposition aux ondes radio établie par le développement énergétique DURABLE.

Ces exigences un SAR limite de 1,6 W/kg en moyenne pour un gramme de tissu. La valeur SAR la plus élevée signalée en vertu de cette norme lors de la certification de produit à utiliser lorsqu'il est correctement porté sur le corps.

部件名称	有害物质					
	铅 (Pb)	汞 (Hg)	镉 (Cd)	六价铬 (Cr <sup>+6</sup> )	多溴联苯 (PBB)	多溴二苯醚 (PBDE)
线路板	×	○	○	○	○	○
外壳	×	○	○	○	○	○
金属部件 (铜合金)	×	○	○	○	○	○
内部线材	×	○	○	○	○	○

其他配件	×	○	○	○	○	○
------	---	---	---	---	---	---

本表格依据SJ/T 11364 的规定编制。  
○：表示该有害物质在该部件所有均质材料中的含量均在GB/T 26572 规定的限量要求以下。  
×：表示该有害物质至少在该部件的某一均质材料中的含量超出GB/T 26572 规定的限量要求。  
（产品符合欧盟ROHS指令环保要求）

5150-5350MHz,仅限室内使用



### KCC Compliance Notice

“해당무선설비는 운용 중 전파혼신 가능성이 있으므로 인명안전과 관련된 서비스는 할 수 없습니다.”

“해당 무선설비는 운용 중 전파혼신 가능성이 있음”

### NCC Compliance Notice

取得審驗證明之低功率射頻器材，非經核准，公司、商號或使用者均不得擅自變更頻率、加大功率或變更原設計之特性及功能。低功率射頻器材之使用不得影響飛航安全及干擾合法通信；經發現有干擾現象時，應立即停用，並改善至無干擾時方得繼續使用。前述合法通信，指依電信管理法規定作業之無線電通信。低功率射頻器材須忍受合法通信或工業、科學及醫療用電波輻射性電機設備之干擾。

注意：

應避免影響附近雷達系統之操作。

高增益指向性天線只得應用於固定式點對點系統。



**EU Compliance Statement:** SZ DJI Osmo Technology Co., Ltd. hereby declares that this device is in compliance with the essential requirements and other relevant provisions of the Directive 2014/53/EU.

A copy of the EU Declaration of Conformity is available online at [www.dji.com/euro-compliance](http://www.dji.com/euro-compliance)

EU contact address: DJI GmbH, Industriestrasse 12, 97618, Niederlauer, Germany

**GB Compliance Statement:** SZ DJI Osmo Technology Co., Ltd. hereby declares that this device is in compliance with the essential requirements and other relevant provisions of Radio Equipment Regulations 2017.



A copy of the GB Declaration of Conformity is available online at [www.dji.com/euro-compliance](http://www.dji.com/euro-compliance)

**Declaración de cumplimiento UE:** SZ DJI Osmo Technology Co., Ltd. por la presente declara que este dispositivo cumple los requisitos básicos y el resto de provisiones relevantes de la Directiva 2014/53/EU.

Hay disponible online una copia de la Declaración de conformidad UE en [www.dji.com/euro-compliance](http://www.dji.com/euro-compliance)

Dirección de contacto de la UE: DJI GmbH, Industriestrasse 12, 97618, Niederlauer, Germany

**EU-verklaring van overeenstemming:** SZ DJI Osmo Technology Co., Ltd. verklaart hierbij dat dit apparaat voldoet aan de essentiële vereisten en andere relevante bepalingen van Richtlijn 2014/53/EU.

De EU-verklaring van overeenstemming is online beschikbaar op [www.dji.com/euro-compliance](http://www.dji.com/euro-compliance)

Contactadres EU: DJI GmbH, Industriestrasse 12, 97618, Niederlauer, Germany

**Declaração de conformidade da UE:** A SZ DJI Osmo Technology Co., Ltd. declara, através deste documento, que este dispositivo está em conformidade com os requisitos essenciais e outras disposições relevantes da Diretiva 2014/53/EU.

Existe uma cópia da Declaração de conformidade da UE disponível online em [www.dji.com/euro-compliance](http://www.dji.com/euro-compliance)

Endereço de contacto na UE: DJI GmbH, Industriestrasse 12, 97618, Niederlauer, Germany

**Dichiarazione di conformità UE:** SZ DJI Osmo Technology Co., Ltd. dichiara che il presente dispositivo è conforme ai requisiti essenziali e alle altre disposizioni rilevanti della direttiva 2014/53/EU.

Una copia della dichiarazione di conformità UE è disponibile online all'indirizzo Web [www.dji.com/euro-compliance](http://www.dji.com/euro-compliance)

Indirizzo di contatto UE: DJI GmbH, Industriestrasse 12, 97618, Niederlauer, Germany

**Déclaration de conformité UE :** Par la présente, SZ DJI Osmo Technology Co., Ltd. déclare que cet appareil est conforme aux principales exigences et autres clauses pertinentes de la directive européenne 2014/53/EU.

Une copie de la déclaration de conformité UE est disponible sur le site [www.dji.com/euro-compliance](http://www.dji.com/euro-compliance)

Adresse de contact pour l'UE : DJI GmbH, Industriestrasse 12, 97618, Niederlauer, Germany

#### PRÉCAUTIONS D'USAGE DE L'APPAREIL

N'utilisez pas l'appareil dans un hôpital, un avion ou un équipement automobile en raison des radiofréquences qui peuvent produire des interférences

- Maintenez une distance minimale de 15 cm entre votre appareil et un stimulateur cardiaque pour éviter toute interférence

Eloigner les équipements radioélectriques du ventre des femmes enceintes.

Eloigner les équipements radioélectriques du bas-ventre des adolescents.

Le débit d'absorption spécifique (DAS) local quantifie l'exposition de l'utilisateur aux ondes électromagnétiques de l'équipement concerné. Le DAS maximal autorisé est de 2 W/ kg pour la tête et le tronc et de 4 W/ kg pour les membres.

La ou les valeurs du débit d'absorption spécifique des RXD2: DAS tronc: 1.029 W/ kg;

**EU-Compliance:** Hiermit erklärt SZ DJI Osmo Technology Co., Ltd., dass dieses Gerät den wesentlichen Anforderungen und anderen einschlägigen Bestimmungen der EU-Richtlinie 2014/53/EU entspricht.

Eine Kopie der EU-Konformitätserklärung finden Sie online auf [www.dji.com/euro-compliance](http://www.dji.com/euro-compliance)  
Kontaktadresse innerhalb der EU: DJI GmbH, Industriestrasse 12, 97618, Niederlauer, Germany

**Декларация за съответствие на ЕС:** SZ DJI Osmo Technology Co., Ltd. декларира, че това устройство отговаря на основните изисквания и другите приложими разпоредби на Директива 2014/53/ЕС.

Копие от Декларацията за съответствие на ЕС ще намерите онлайн на адрес [www.dji.com/euro-compliance](http://www.dji.com/euro-compliance)

Адрес за контакт за ЕС: DJI GmbH, Industriestrasse 12, 97618, Niederlauer, Германия

**Prohlášení o shodě pro EU:** Společnost SZ DJI Osmo Technology Co., Ltd. tímto prohlašuje, že tohle zařízení vyhovuje základním požadavkům a dalším příslušným ustanovením směrnice 2014/53/EU.

Kopie prohlášení o shodě pro EU je k dispozici on-line na webu [www.dji.com/euro-compliance](http://www.dji.com/euro-compliance)  
Kontaktní adresa v EU: DJI GmbH, Industriestrasse 12, 97618, Niederlauer, Německo

**EU-overensstemmelseserklæring:** SZ DJI Osmo Technology Co., Ltd. erklærer hermed, at denne enhed er i overensstemmelse med de væsentlige krav og andre relevante bestemmelser i direktiv 2014/53/EU.

Der er en kopi af EU-overensstemmelseserklæringen tilgængelig online på [www.dji.com/euro-compliance](http://www.dji.com/euro-compliance)

EU-kontaktadresse: DJI GmbH, Industriestrasse 12, 97618, Niederlauer, Tyskland

**Δήλωση Συμμόρφωσης ΕΕ:** Η SZ DJI Osmo Technology Co., Ltd. δια του παρόντος δηλώνει ότι η συσκευή αυτή συμμορφώνεται με τις βασικές απαιτήσεις και άλλες σχετικές διατάξεις της Οδηγίας 2014/53/ΕΕ.

Αντίγραφο της Δήλωσης Συμμόρφωσης ΕΕ διατίθεται ηλεκτρονικά στη διεύθυνση [www.dji.com/euro-compliance](http://www.dji.com/euro-compliance)

Διεύθυνση επικοινωνίας στην ΕΕ: DJI GmbH, Industriestrasse 12, 97618, Niederlauer, Γερμανία

**ELi vastavuskinnitus** Käesolevaga teatab SZ DJI Osmo Technology Co., Ltd., et see seade on kooskõlas direktiivi 2014/53/EL oluliste nõuete ja muude asjakohaste sätetega.

ELi vastavusdeklaratsiooni koopia on kättesaadav veebis aadressil [www.dji.com/euro-compliance](http://www.dji.com/euro-compliance)  
Kontaktaadress ELis: DJI GmbH, Industriestrasse 12, 97618, Niederlauer, Saksamaa

**Pranešimas dėl atitikties ES reikalavimams** Bendrovė „SZ DJI Osmo Technology Co., Ltd.“ tvirtina,

kad šis prietaisas atitinka pagrindinius 2014/53/ES direktyvos reikalavimus ir kitas susijusias nuostatas.

ES atitikties deklaracijos kopiją galite rasti adresu [www.dji.com/euro-compliance](http://www.dji.com/euro-compliance)

ES kontaktinis adresas: „DJI GmbH“, Industriestrasse 12, 97618, Niederlauer, Germany (Vokietija)

**ES atbilstības paziņojums:** SZ DJI Osmo Technology Co., Ltd ar šo apliecina, ka šī ierīce atbilst direktīvas 2014/53/ES pamatprasībām un pārējiem būtiskiem nosacījumiem.

ES atbilstības deklarācijas kopija pieejama tiešsaistē vietnē [www.dji.com/euro-compliance](http://www.dji.com/euro-compliance)

ES kontaktadrese: DJI GmbH, Industriestrasse 12, 97618, Niederlauer, Vācija

**EU:n vaatimustenmukaisuusvakuutus:** SZ DJI Osmo Technology Co., Ltd. ilmoittaa täten, että tämä laite on direktiivin 2014/53/EU olennaisten vaatimusten ja sen muiden asiaankuuluvien ehtojen mukainen.

Kopio EU:n vaatimustenmukaisuusvakuutuksesta on saatavana verkossa osoitteessa [www.dji.com/euro-compliance](http://www.dji.com/euro-compliance)

Yhteystiedot EU:ssa: DJI GmbH, Industriestrasse 12, 97618, Niederlauer, Germany

**RÁITEAS Comhlíonta an AE:** Dearbhaíonn SZ DJI Osmo Technology Co., Ltd. leis seo go bhfuil an gléas seo de réir na gceanglas riachtanach agus na bhforálacha ábhartha eile sa Treoir 2014/53/AE.

Tá coip de Dhearbhú Comhréireachta an AE ar fáil ar líne ag [www.dji.com/euro-compliance](http://www.dji.com/euro-compliance)

Seoladh teagmhála san AE: DJI GmbH, Industriestrasse 12, 97618, Niederlauer, Germany

**Dikjarazzjoni ta' Konformità tal-UE:** SZ DJI Osmo Technology Co., Ltd. hawnhekk tiddikjara li dan l-apparat huwa konformi mar-rekwiziti essenzjali u ma' dispożizzjonijiet relevanti oħra tad-Direttiva 2014/53/UE.

Kopja tad-Dikjarazzjoni ta' Konformità tal-UE hija disponibbli onlajn fis-sit [www.dji.com/euro-compliance](http://www.dji.com/euro-compliance)

Indirizz ta' kuntatt tal-UE: DJI GmbH, Industriestrasse 12, 97618, Niederlauer, il-Ġermanja

**Declarația UE de conformitate:** Prin prezenta, SZ DJI Osmo Technology Co., Ltd. declară faptul că acest dispozitiv este conform cu cerințele esențiale și celelalte prevederi relevante ale Directivei 2014/53/UE.

Un exemplar al Declarației UE de conformitate este disponibil online, la adresa [www.dji.com/euro-compliance](http://www.dji.com/euro-compliance)

Adresa de contact pentru UE: DJI GmbH, Industriestrasse 12, 97618, Niederlauer, Germania

**Izjava EU o skladnosti:** Družba SZ DJI Osmo Technology Co., Ltd. izjavlja, da ta naprava ustreza osnovnim zahtevam in drugim ustreznim določbam Direktive 2014/53/EU.

Kopija izjave EU o skladnosti je na voljo na spletu na [www.dji.com/euro-compliance](http://www.dji.com/euro-compliance)

Kontaktni naslov EU: DJI GmbH, Industriestrasse 12, 97618, Niederlauer, Nemčija

**EU Izjava o skladnosti:** Tvrtka SZ DJI Osmo Technology Co. Ltd. izjavljuje da je ovaj uređaj izrađen u skladu s osnovnim zahtjevima i ostalim relevantnim odredbama Direktive 2014/53/EU.

Kopija EU Izjave o skladnosti dostupna je na mrežnoj stranici [www.dji.com/euro-compliance](http://www.dji.com/euro-compliance)

Adresa EU kontakta: DJI GmbH, Industriestrasse 12 97618, Niederlauer, Njemačka

**Vyhlasenie o zhode EÚ:** SZ DJI Osmo Technology Co., Ltd. týmto vyhlasuje, že toto zariadenie je v zhode so základnými požiadavkami a ďalšími relevantnými ustanoveniami smernice 2014/53/EÚ. Kópia tohto Vyhlasenia o zhode EÚ je k dispozícii online na [www.dji.com/euro-compliance](http://www.dji.com/euro-compliance)  
Kontaktná adresa v EÚ: DJI GmbH, Industriestrasse 12, 97618, Niederlauer, Nemecko

**Deklaracja zgodności UE:** Firma SZ DJI Osmo Technology Co., Ltd. niniejszym oświadcza, że przedmiotowe urządzenie jest zgodne z zasadniczymi wymogami i innymi stosownymi postanowieniami dyrektywy 2014/53/UE.

Kopię deklaracji zgodności UE można znaleźć w Internecie na stronie [www.dji.com/euro-compliance](http://www.dji.com/euro-compliance)

Adres do kontaktu w UE: DJI GmbH, Industriestrasse 12, 97618, Niederlauer, Niemcy

**EU megfeleléségi nyilatkozat:** A DJI Osmo Technology Co., Ltd. ezúton megerősíti, hogy ez az eszköz megfelel a 2014/53/EU Irányelv alapvető követelményeinek és más vonatkozó rendelkezéseinek.

Az EU megfeleléségi nyilatkozat másolata elérhető a [www.dji.com/euro-compliance](http://www.dji.com/euro-compliance) oldalon

EU kapcsolati cím: DJI GmbH, Industriestrasse 12, 97618, Niederlauer, Németország

**EU-försäkran om efterlevnad:** SZ DJI Osmo Technology Co., Ltd. härmed förklarar att denna enhet uppfyller de väsentliga kraven och andra relevanta bestämmelser i direktivet 2014/53/EU.

En kopia av EU-försäkran om efterlevnad finns att tillgå online på adressen [www.dji.com/euro-compliance](http://www.dji.com/euro-compliance)

Kontaktadress EU: DJI GmbH, Industriestrasse 12, 97618, Niederlauer, Tyskland

**Yfirlýsing um fylgni við reglur ESB:** SZ DJI Osmo Technology Co., Ltd. lýsir hér með yfir að þetta tæki hlíti mikilvægum kröfum og öðrum viðeigandi ákvæðum tilskipunar 2014/53/ESB.

Nálgast má eintak af ESB-samræmisyfirlýsingunni á netinu á [www.dji.com/euro-compliance](http://www.dji.com/euro-compliance)

Heimilisfang ESB-tengiliðar: DJI GmbH, Industriestrasse 12, 97618, Niederlauer, Germany

**AB Uygunluk Beyanı:** SZ DJI Osmo Technology Co., Ltd. bu belge ile bu cihazın temel gerekliliklere ve 2014/53/EU sayılı Direktifin diğer ilgili hükümlerine uygun olduğunu beyan eder.

AB Uygunluk Beyanının bir kopyasına [www.dji.com/euro-compliance](http://www.dji.com/euro-compliance) adresinden çevrim içi olarak ulaşılabilir

AB için iletişim adresi: DJI GmbH, Industriestrasse 12, 97618, Niederlauer, Almanya

CAUTION: RISK OF EXPLOSION IF BATTERY IS REPLACED BY AN INCORRECT TYPE. DISPOSE OF USED BATTERIES ACCORDING TO THE INSTRUCTIONS

#### Environmentally friendly disposal



Old electrical appliances must not be disposed of together with the residual waste, but have to be disposed of separately. The disposal at the communal collecting point via private persons is for free. The owner of old appliances is

responsible to bring the appliances to these collecting points or to similar collection points. With this little personal effort, you contribute to recycle valuable raw materials and the treatment of toxic substances.

### **Umweltfreundliche Entsorgung**

Elektro-Altgeräte dürfen nicht mit gewöhnlichem Abfall entsorgt werden und müssen separat entsorgt werden. Die Entsorgung an kommunalen Sammelstellen ist für Privatpersonen kostenlos. Die Eigentümer der Altgeräte sind für den Transport zu den Sammelstellen verantwortlich. Durch diesen geringen Aufwand können Sie zur Wiederverwertung von wertvollen Rohmaterialien beitragen und dafür sorgen, dass umweltschädliche und giftige Substanzen ordnungsgemäß unschädlich gemacht werden.

### **Tratamiento de residuos responsable con el medio ambiente**

Los aparatos eléctricos viejos no pueden desecharse junto con los residuos orgánicos, sino que deben ser desechados por separado. Existen puntos limpios donde los ciudadanos pueden dejar estos aparatos gratis. El propietario de los aparatos viejos es responsable de llevarlos a estos puntos limpios o similares puntos de recogida. Con este pequeño esfuerzo estás contribuyendo a reciclar valiosas materias primas y al tratamiento de residuos tóxicos.

### **Mise au rebut écologique**

Les appareils électriques usagés ne doivent pas être éliminés avec les déchets résiduels. Ils doivent être éliminés séparément. La mise au rebut au point de collecte municipal par l'intermédiaire de particuliers est gratuite. Il incombe au propriétaire des appareils usagés de les apporter à ces points de collecte ou à des points de collecte similaires. Avec ce petit effort personnel, vous contribuez au recyclage de matières premières précieuses et au traitement des substances toxiques.

### **Smaltimento ecologico**

I vecchi dispositivi elettrici non devono essere smaltiti insieme ai rifiuti residui, ma devono essere smaltiti separatamente. Lo smaltimento da parte di soggetti privati presso i punti di raccolta pubblici è gratis. È responsabilità del proprietario dei vecchi dispositivi portarli presso tali punti di raccolta o punti di raccolta analoghi. Grazie a questo piccolo impegno personale contribuirete al riciclo di materie prime preziose e al corretto trattamento di sostanze tossiche.

### **Milieuvriendelijk afvoeren**

Oude elektrische apparaten mogen niet worden weggegooid samen met het restafval, maar moeten afzonderlijk worden afgevoerd. Afvoeren via het gemeentelijke inzamelpunt is gratis voor particulieren. De eigenaar van oude toestellen is verantwoordelijk voor het inleveren van de apparaten op deze of vergelijkbare inzamelpunten. Met deze kleine persoonlijke inspanning lever je een bijdrage aan de recycling van waardevolle grondstoffen en de verwerking van giftige stoffen.

### **Eliminação ecológica**

Os aparelhos elétricos antigos não podem ser eliminados juntamente com os materiais residuais.

Têm de ser eliminados separadamente. A eliminação no ponto de recolha público através de entidades particulares é gratuita. É da responsabilidade do proprietário de aparelhos antigos levá-los a estes pontos de recolha ou a pontos de recolha semelhantes. Com este pequeno esforço pessoal, contribui para a reciclagem de matérias-primas úteis e para o tratamento de substâncias tóxicas.

#### **Изхвърляне с оглед опазване на околната среда**

Старите електрически уреди не трябва да се изхвърлят заедно с битовите отпадъци, а отделно. Изхвърлянето в общинския пункт за събиране на отпадъци от частни лица е безплатно. Собственикът на старите уреди е отговорен за пренасянето на уредите до тези или до подобни събирателни пунктове. С това малко собствено усилие допринасяте за рециклирането на ценни суровини и за обработката на токсични вещества.

#### **Ekologicky šetrná likvidace**

Stará elektrická zařízení nesmějí být likvidována spolu se zbytkovým odpadem, ale musí být likvidována samostatně. Likvidace na komunálních sběrných místech prostřednictvím soukromých osob je bezplatná. Vlastník starých zařízení odpovídá za to, že je donese do těchto sběrných míst nebo na obdobná sběrná místa. Tímto můžete přispět k recyklaci hodnotných surovin a zpracování toxických látek.

#### **Miljøvenlig bortskaffelse**

Gamle elektriske apparater må ikke bortskaffes sammen med restaffald, men skal bortskaffes separat. Bortskaffelse på et fælles indsamlingssted er gratis for privatpersoner. Ejere af gamle apparater er ansvarlige for at bringe apparater hen til disse indsamlingssteder eller til lignende indsamlingssteder. Med denne lille personlige indsats bidrager du til genanvendelse af værdifulde råvarer og behandlingen af giftige stoffer.

#### **Απόρριψη φιλική προς το περιβάλλον**

Οι παλιές ηλεκτρικές συσκευές δεν πρέπει να απορρίπτονται μαζί με τα υπολειμματικά απόβλητα, αλλά ξεχωριστά. Η απόρριψη στο δημοτικό σημείο συλλογής μέσω ιδιωτών γίνεται χωρίς χρέωση. Ο κάτοχος παλιών συσκευών είναι υπεύθυνος για τη μεταφορά των συσκευών σε αυτά ή παρόμοια σημεία συλλογής. Μέσω της ατομικής σας προσπάθειας, συμβάλλετε στην ανακύκλωση πολύτιμων πρώτων υλών και την επεξεργασία των τοξικών ουσιών.

#### **Keskkonnasäästlik kasutuselt kõrvaldamine**

Vanu elektriseadmeid ei tohi ära visata koos olmejäätmetega, vaid tuleb koguda ja kasutuselt kõrvaldada eraldi. Kohaliku omavalitsuse elektroonikaromude kogumispunktis on äraandmine eraisikutele tasuta. Vanade seadmete sellistesse või sarnastesse kogumispunktidesse toimetamise eest vastutavad seadmete omanikud. Selle väikese isikliku panusega aitate kaasa väärtusliku toorme ringlussevõtule ja mürgiste ainete töötlemisele.

#### **Utilizavimas nekenkiant aplinkai**

Senų elektrinių prietaisų negalima išmesti kartu su buitinėmis atliekomis; juos būtina utilizuoti atskirai. Tokių prietaisų utilizavimas per komunalinius atliekų surinkimo punktus yra nemokamas.

Elektrinių prietaisų savininkai utilizuojamus prietaisus privalo priduoti į atitinkamus arba analogiškus atliekų surinkimo punktus. Tokiu būdu, įdėdami nedaug pastangų, prisidėsite prie vertingų medžiagų perdirbimo ir aplinkos apsaugojimo nuo toksinių medžiagų.

#### **Videi draudzīga atkritumu likvidēšana**

Vecas elektriskās ierīces nedrīkst likvidēt kopā ar pārējiem atkritumiem, bet tās jālikvidē atsevišķi. Privātpersonām atkritumu likvidēšana komunālajā savākšanas punktā ir bez maksas. Veco ierīču īpašnieks ir atbildīgs par ierīču nogādāšanu šajos savākšanas punktos vai līdzīgos savākšanas punktos. Ar šīm nelielām personiskajām pūlēm jūs veicināt vērtīgu izejmateriālu pārstrādi un toksisko vielu apstrādi.

#### **Hävittäminen ympäristöystävällisesti**

Vanhoja sähkölaitteita ei saa hävittää kaatopaikkajätteen mukana, vaan ne on hävitettävä erikseen. Kunnalliseen keräyspisteeseen vieminen on yksityishenkilölle ilmaista. Vanhojen laitteiden omistaja vastaa laitteiden toimittamisesta kyseisiin keräyspisteisiin tai vastaaviin. Tällä vähäisellä henkilökohtaisella vaivalla edistät omalta osaltasi arvokkaiden raaka-aineiden kierrätystä ja myrkyllisten aineiden käsittelyä.

#### **Diúscairt neamhdhíobhálach don chomhshaol**

Níor cheart seanghléasanna leictreacha a dhiúscairt leis an dramhaíl iarmharach, ach caithfear iad a chur de láimh astu féin. Tá an diúscairt ag an ionad bailiúcháin pobail ag daoine príobháideacha saor in aisce. Tá freagracht ar úinéir seanghléasanna na gléasanna a thabhairt chuig na hionaid bhailiúcháin sin nó chuig ionaid bhailiúcháin den chineál céanna. Le hiarracht bheag phearsanta mar sin, cuidíonn tú le hamhábhair luachmhara a athchúrsáil agus le substaintí tocsaineacha a chóireáil

#### **Rimi li jirrispetta l-ambjent**

L-apparat elettriku qadim ma għandux jintrema flimkien ma' skart residwu, iżda għandu jintrema b'mod separat. Ir-rimi fil-post tal-ġbir komunali minn persuni privati huwa b'xejn. Is-sit ta' apparat qadim huwa responsabbli biex iġib l-apparat f'dawn il-postijiet tal-ġbir jew f'postijiet tal-ġbir simili. B'dan l-isforz personali żgħir, inti tikkontribwixxi għar-riċiklaġġ ta' materja prima prezzjuża u għat-trattament ta' sustanzi tossiċi.

#### **Eliminarea ecologică**

Aparatele electrice vechi nu trebuie aruncate odată cu deșeurile reziduale, ci trebuie eliminate separat. Eliminarea în cadrul punctului de colectare local de către persoane fizice este gratuită. Proprietarii de aparate vechi sunt responsabili pentru transportul acestora la respectivele puncte de colectare sau la alte puncte de colectare similare. Prin acest efort personal nesemnificativ, puteți contribui la reciclarea materiilor prime valoroase și la tratarea substanțelor toxice.

#### **Okolju prijazno odlaganje**

Starih električnih aparatov ne smete odvreči skupaj z ostanki odpadkov, temveč ločeno. Odlaganje na komunalnem zbirnem mestu je za fizične osebe brezplačno. Lastnik starih naprav je odgovoren, da jih pripelje do teh ali podobnih zbirnih mest. S tako malo osebnega truda

prispevate k recikliranju dragocenih surovin in obdelavi strupenih snovi.

### **Ekološko odlaganje**

Stari električni uređaji ne smiju se odlagati zajedno s kućnim otpadom, već ih treba odlagati odvojeno. Odlaganje na komunalnom sabirnom mjestu od strane privatnih osoba je besplatno. Vlasnik starih uređaja dužan je donijeti uređaje do tih sabirnih mjesta ili sličnih sabirnih mjesta. Ovim malim osobnim naporom doprinosite recikliranju vrijednih sirovina i pravilnoj obradi otrovnih tvari.

### **Ekologická likvidácia**

Staré elektrospotrebiče sa nesmú likvidovať spolu so zvyškovým odpadom, ale musia sa zlikvidovať samostatne. Likvidácia v komunálnom zbernom mieste prostredníctvom súkromných osôb je bezplatná. Majiteľ starých spotrebičov je zodpovedný za prinesenie spotrebičov na tieto zberné miesta alebo na podobné zberné miesta. Týmto malým osobným úsilím prispievate k recyklovaniu cenných surovín a spracovaniu toxických látok

### **Utylizacja przyjazna dla środowiska**

Nie można usuwać starych urządzeń elektrycznych wraz z pozostałymi odpadami. Wymagają one oddzielnej utylizacji. Utylizacja przez osoby prywatne w punkcie zbiórki odpadów komunalnych jest darmowa. Właściciel starych urządzeń jest odpowiedzialny za dostarczenie ich do takich lub podobnych punktów zbiórki. Zadając sobie tak niewielki trud, przyczyniasz się do recyklingu cennych surowców i odpowiedniego postępowania z substancjami toksycznymi.

### **Környezetbarát hulladékkezelés**

A régi elektromos készülékeket nem szabad a nem szelektíven gyűjtött hulladékkal együtt kidobni, hanem a hulladékkezelésüket elkülönítve kell végezni. A közösségi gyűjtőpontokon a magánszemélyek ingyenesen leadhatják ezeket. A régi készülékek tulajdonosai felelnek azért, hogy a készülékeket ezekre a gyűjtőpontokra, vagy más gyűjtőpontokra elhozzák. Ezzel a kis személyes erőfeszítéssel Ön is hozzájárul az értékes nyersanyagok újrahasznosításához és a mérgező anyagok kezeléséhez.

### **Miljövämlig hantering av avfall**

Gamla elektriska apparater får inte kasseras tillsammans med restavfallet utan måste kasseras separat. Kassering på den lokala insamlingsplatsen för privatpersoner är gratis. Ägaren av gamla apparater ansvarar för att ta apparaterna till dessa insamlingsplatser eller till liknande insamlingsplatser. Med denna lilla personliga insats bidrar du till återvinning av värdefulla råvaror och hantering av giftiga ämnen.

### **Umhverfisvæn förgun**

Ekki má farga gömlum raftækjum með úrgangisleifum, heldur þarf að farga þeim sérstaklega. Förgun á almennum söfnunarstöðum er ókeypis fyrir einstaklinga. Eigandi gamalla tækja ber ábyrgð á að koma með tækin á þessa söfnunarstaði eða á svipaða söfnunarstaði. Með þessu litla persónulega átaki stuðlar þú að endurvinnslu verðmætra hráefna og meðferð eitrufna.



### Çevre dostu bertaraf

Eski elektrikli cihazlar, diğ er atıklarla birlikte bertaraf edilmemeli, ayrıca atılmalıdır. Özel kişiler aracılığıyla genel toplama noktasına bertaraf işlemi ücretsiz olarak yapılmaktadır. Eski cihazların sahibi, cihazları bu toplama noktalarına veya benzer toplama noktalarına getirmekten sorumludur. Bu az miktardaki kişisel çabayla, değerli ham maddelerin geri dönüştürülmesine ve toksik maddelerin işleme alınmasına katkıda bulunmuş olursunuz.

This device is restricted to indoor use when operating in the 5150-5250MHz frequency range in all EU/EFTA member states and Turkey.

Im Frequenzbereich 5150 – 5250 MHz darf dieses Gerät in allen EU/EFTA-Mitgliedsstaaten und der

Türkei nur innerhalb von Gebäuden verwendet werden.

Este dispositivo está limitado a su uso en interiores cuando esté funcionando en el rango de frecuencia de 5150-5250 MHz en todos los estados miembros de la UE/AELC y Turquía.

Cet appareil est réservé à un usage en intérieur dans une plage de fréquence de 5 150 à 5 250 MHz

dans tous les pays membres de l'Union Européenne et de l'Association européenne de libre-échange, ainsi qu'en Turquie.

Il presente dispositivo è limitato all'uso in ambienti interni se utilizzato nell'intervallo di frequenze di funzionamento 5150-5250 MHz in tutti gli stati dell'UE/AELS e in Turchia.

Dit apparaat mag in landen van de EU/EFTA in Turkije alleen in binnenruimtes worden gebruikt wanneer het frequentiebereik 5150-5250 MHz is ingesteld.

Este dispositivo está restrito para uso em áreas internas ao operar na faixa de frequência de 5150-5250MHz em todos os estados-membros da UE/EFTA e Turquia.

Использование данного устройства в частотном диапазоне 5150-5250 МГц разрешается только в помещениях во всех странах, входящих в ЕС/ЕАСТ, а также в Турции.

			
BE	BG	CZ	DK
DE	EE	IE	EL
ES	FR	HR	IT
CY	LV	LT	LU
HU	MT	NL	AT
PL	PT	RO	SI
SK	FI	SE	UK(NI)
TR	NO	CH	IS
LI			

### Thailand Warning message

เครื่องโทรคมนาคมและอุปกรณ์นี้ มีความสอดคล้องตามข้อกำหนดของ กทช.

### Mexico Warning message

“La operación de este equipo está sujeta a las siguientes dos condiciones: (1) es posible que este equipo o dispositivo no cause interferencia perjudicial y (2) este equipo o dispositivo debe aceptar cualquier interferencia, incluyendo la que pueda causar su operación no deseada.”

**Brazil Warning message**

Informações sobre Regulamentação.

Este equipamento está certificado e homologado pela ANATEL.

Para maiores informações, consulte o site da ANATEL: [www.anatel.gov.br](http://www.anatel.gov.br).

Este equipamento não tem direito à proteção contra interferência prejudicial e não pode causar interferência em sistemas devidamente autorizados.



The terms HDMI, HDMI High-Definition Multimedia Interface, and the HDMI Logo are trademarks or registered trademarks of HDMI Licensing Administrator, Inc.