

SINAMICS S120

Control Units and Supplementary System Components

Manual 11/2009

SINAMICS

SIEMENS

SIEMENS

SINAMICS

S120 SINAMICS S120 Control Units and additional system components

Manual

Preface

System overview

1

Control Units

2

Additional system
components

3

Encoder system connection

4

Information on
electromagnetic compatibility
(EMC)

5

Appendix A

A

Appendix B

B



Fax template

C

Legal information

Warning notice system

This manual contains notices you have to observe in order to ensure your personal safety, as well as to prevent damage to property. The notices referring to your personal safety are highlighted in the manual by a safety alert symbol, notices referring only to property damage have no safety alert symbol. These notices shown below are graded according to the degree of danger.

 DANGER
indicates that death or severe personal injury will result if proper precautions are not taken.
 WARNING
indicates that death or severe personal injury may result if proper precautions are not taken.
 CAUTION
with a safety alert symbol, indicates that minor personal injury can result if proper precautions are not taken.
CAUTION
without a safety alert symbol, indicates that property damage can result if proper precautions are not taken.
NOTICE
indicates that an unintended result or situation can occur if the corresponding information is not taken into account.

If more than one degree of danger is present, the warning notice representing the highest degree of danger will be used. A notice warning of injury to persons with a safety alert symbol may also include a warning relating to property damage.

Qualified Personnel

The product/system described in this documentation may be operated only by **personnel qualified** for the specific task in accordance with the relevant documentation for the specific task, in particular its warning notices and safety instructions. Qualified personnel are those who, based on their training and experience, are capable of identifying risks and avoiding potential hazards when working with these products/systems.

Proper use of Siemens products

Note the following:

 WARNING
Siemens products may only be used for the applications described in the catalog and in the relevant technical documentation. If products and components from other manufacturers are used, these must be recommended or approved by Siemens. Proper transport, storage, installation, assembly, commissioning, operation and maintenance are required to ensure that the products operate safely and without any problems. The permissible ambient conditions must be adhered to. The information in the relevant documentation must be observed.

Trademarks

All names identified by ® are registered trademarks of the Siemens AG. The remaining trademarks in this publication may be trademarks whose use by third parties for their own purposes could violate the rights of the owner.

Disclaimer of Liability

We have reviewed the contents of this publication to ensure consistency with the hardware and software described. Since variance cannot be precluded entirely, we cannot guarantee full consistency. However, the information in this publication is reviewed regularly and any necessary corrections are included in subsequent editions.

Preface

SINAMICS documentation

The SINAMICS documentation is sub-divided into 2 parts:

- General documentation/catalogs
- Manufacturer/service documentation

At <http://www.siemens.com/motioncontrol/docu> information is available on the following topics:

- Ordering documentation

Here you will find the current overview of publications

- Downloading documentation

Links to more information for downloading files from Service & Support

- Researching documentation online

Information on DOConCD and direct access to the publications in DOConWeb.

- Individually compiling documentation on the basis of Siemens contents with the My Documentation Manager (MDM), refer to

<http://www.siemens.com/mdm>

The My Documentation Manager offers you a number of features for compiling your own machine documentation

- Training and FAQs

Information on the range of training courses and FAQs (frequently asked questions) are available via the page navigation.

Usage phases

Table 1 Table Preface-1: Phase of use and the available documents/tools

Usage phase	Tools
Orientation	SINAMICS S sales documentation
Planning/engineering	SIZER engineering tool
Decision making/ordering	SINAMICS S Catalogs
Configuring/installation	<ul style="list-style-type: none"> • SINAMICS S120 Equipment Manuals • SINAMICS S150 Operating Instructions
Commissioning	<ul style="list-style-type: none"> • STARTER Parameterizing and Commissioning Tool • SINAMICS S120 Commissioning Manuals • SINAMICS S List Manual • SINAMICS S150 Operating Instructions
Using/operating	<ul style="list-style-type: none"> • SINAMICS S120 Function Manuals • SINAMICS S List Manual • SINAMICS S150 Operating Instructions
Maintenance/Service	<ul style="list-style-type: none"> • SINAMICS S120 Commissioning Manuals • SINAMICS S List Manual • SINAMICS S120 Equipment Manuals • SINAMICS S150 Operating Instructions

Target group

This manual addresses planners, installation and design engineers.

Benefits

This manual provides information on the components and functions of devices so that the target group is capable of installing, setting up, testing, operating, and troubleshooting the devices safely and correctly.

Standard scope

The functionality of the standard scope is described in the following documentation. The machinery construction OEM documents supplements or changes that he makes (the machinery construction OEM).

Functions that are not explained in this documentation may be able to be executed in the drive system. However, no claim can be made regarding the availability of these functions when the equipment is first supplied or in the event of servicing.

Further, for the sake of simplicity, this documentation does not contain all detailed information about all types of the product and cannot cover every conceivable case of installation, operation or maintenance.

Technical Support

If you have any questions, please contact our hotline:

	Europe/Africa
Telephone	+49 180 5050 - 222
Fax	+49 180 5050 - 223
€ 0.14 / min. from German landlines, max. € 0.42 / min. for mobile calls within Germany	
Internet	http://www.siemens.de/automation/support-request

	America
Telephone	+1 423 262 2522
Fax	+1 423 262 2200
E-mail	mailto:techsupport.sea@siemens.com

	Asia/Pacific
Telephone	+86 1064 757575
Fax	+86 1064 747474
E-mail	mailto:support.asia.automation@siemens.com

Note

You will find telephone numbers for other countries for technical support in the Internet:
<http://www.automation.siemens.com/partner>

Spare parts

Spare parts are available on the Internet at:
<http://support.automation.siemens.com/WW/view/de/16612315>

Questions about the documentation

If you have any questions (suggestions, corrections) regarding this documentation, please fax or e-mail us at:

Fax	+49 9131 98 2176
E-mail	E-mail to: docu.motioncontrol@siemens.com

A fax form is available in the appendix of this document.

Internet address for SINAMICS

<http://www.siemens.com/sinamics>.

EC Declarations of Conformity

The EC Declaration of Conformity for the EMC Directive can be found/obtained:

- in the Internet:
<http://support.automation.siemens.com>
under the Product/Order No. 15257461
- at the relevant regional office of the I DT MC Business Unit of Siemens AG

The EC Declaration of Conformity for the EMC Directive can be found/obtained

- in the Internet:
<http://support.automation.siemens.com>
under the Product/Order No. 22383669

Test certificates

The Safety Integrated functions of SINAMICS components are generally certified by independent institutes. An up-to-date list of already certified components is available on request from your local Siemens office. If you have any questions relating to certifications that have not been completed, please ask your Siemens contact.

ESD information

<p> CAUTION</p> <p>Electrostatic sensitive devices (ESDs) are individual components, integrated circuits, or boards that may be damaged by either electrostatic fields or electrostatic discharge.</p> <p>Regulations for handling ESD components:</p> <p>When handling electronic components, you must ensure that the person carrying out the work, the work place, and packaging are properly grounded.</p> <p>Personnel in ESD areas with conductive flooring may only handle electronic components if:</p> <ul style="list-style-type: none">They are grounded with an ESD wrist bandThey are wearing ESD shoes or ESD shoe grounding straps <p>Electronic boards should only be touched if absolutely necessary. They must only be handled on the front panel or, in the case of printed circuit boards, at the edge.</p> <p>Electronic boards must not come into contact with plastics or items of clothing containing synthetic fibers.</p> <p>Boards must only be placed on conductive surfaces (work surfaces with ESD surface, conductive ESD foam, ESD packing bag, ESD transport container).</p> <p>Electronic components may not be placed near display units, monitors or televisions (minimum distance from the screen > 10 cm).</p> <p>Measurements may only be taken on boards when the measuring instrument is grounded (via protective conductors, for example) or the measuring probe is briefly discharged before measurements are taken with an isolated measuring device (for example, touching a bare metal housing).</p>

<p> DANGER</p> <p>Electrical, magnetic, and electromagnetic fields (EMF) occurring during operation can pose a danger to people in the direct vicinity of the product, especially people with pacemakers, implants, or similar.</p> <p>The relevant directives and standards must be observed by the machine/plant operators and people present in the vicinity of the product. These are, for example, EMF Directive 2004/40/EEC and standards EN 12198-1 to -3 applying to the European Economic Area (EEA) and in Germany the accident prevention regulation BGV 11 and the associated rule BGR 11 "Electromagnetic fields" from the German employer's liability accident insurance association.</p> <p>These state that a hazard analysis must drawn up for every workplace, from which measures for reducing dangers and their impact on people are derived and applied, and exposure and danger zones are defined and observed.</p> <p>The relevant safety notes in each chapter must be observed.</p>

Safety information

 **DANGER**

Commissioning is absolutely prohibited until it has been completely ensured that the machine, in which the components described here are to be installed, is in full compliance with the provisions of the EC Machinery Directive.

Only qualified personnel may install, commission and service SINAMICS S units.

The personnel must take into account the information provided in the technical customer documentation for the product, and be familiar with and observe the specified danger and warning notices.

Operational electrical equipment and motors have parts and components which are at hazardous voltage levels that may cause serious injuries or death when touched.

All work on the electrical system must be carried out when the system has been disconnected from the power supply.

 **WARNING**

Correct and safe operation of SINAMICS S equipment assumes correct transportation, storage, setup, and installation, as well as careful operation and maintenance.

The details in the catalogs and proposals also apply to the design of special equipment versions.

In addition to the danger and warning information provided in the technical customer documentation, the applicable national, local, and system-specific regulations and requirements must be taken into account.

According to EN 61800-5-1 and UL 508 only safely isolated protective extra-low voltages of the electronic modules may be connected to all connections and terminals.

 **DANGER**



Using protection against direct contact via DVC A (PELV) is only permissible in areas with equipotential bonding and in dry rooms indoors. If these conditions are not fulfilled, then other protective measures against electric shock must be used (e.g. protection using protective impedances or limited voltage or using protective classes I and II).

CAUTION

Operating the components in the immediate vicinity (< 1.5 m) of mobile telephones with a transmitting power of > 1 W may lead to incorrect functioning of the devices.

Explanation of the symbols

Table 2 Symbols

Symbol	Meaning
	Protective earth (PE)
	Ground (e.g. M 24 V)
	Functional ground Equipotential bonding

Residual risks of power drive systems

When carrying out a risk assessment of a machine in accordance with the EU Machinery Directive, the machine manufacturer must consider the following residual risks associated with the control and drive components of a power drive system (PDS).

1. Unintentional movements of driven machine components during commissioning, operation, maintenance, and repairs caused by, for example:
 - Hardware defects and/or software errors in the sensors, controllers, actuators, and connection technology
 - Response times of the controller and drive
 - Operating and/or ambient conditions not within the scope of the specification
 - Parameterization, programming, cabling, and installation errors
 - Use of radio devices / cellular phones in the immediate vicinity of the controller
 - External influences / damage
2. Exceptional temperatures as well as emissions of light, noise, particles, or gas caused by, for example:
 - Component malfunctions
 - Software errors
 - Operating and/or ambient conditions not within the scope of the specification
 - External influences / damage
3. Hazardous shock voltages caused by, for example:
 - Component malfunctions
 - Influence of electrostatic charging
 - Induction of voltages in moving motors
 - Operating and/or ambient conditions not within the scope of the specification
 - Condensation / conductive contamination
 - External influences / damage
4. Electrical, magnetic and electromagnetic fields generated in operation that can pose a risk to people with a pacemaker, implants or metal replacement joints, etc. if they are too close.
5. Release of environmental pollutants or emissions as a result of improper operation of the system and/or failure to dispose of components safely and correctly.

For more information about residual risks of the power drive system components, see the relevant chapters in the technical user documentation.

Table of contents

	Preface	5
1	System overview	21
1.1	Field of application	21
1.2	Platform Concept and Totally Integrated Automation	22
1.3	Introduction	23
1.4	SINAMICS S120 components.....	26
1.5	System data	28
1.6	Standards.....	30
2	Control Units	33
2.1	Introduction	33
2.2	Control Unit CU320	37
2.2.1	Description	37
2.2.2	Safety information	38
2.2.3	Interface description.....	39
2.2.3.1	Overview	39
2.2.3.2	Connection example	40
2.2.3.3	X100 - X103 DRIVE-CLiQ interfaces.....	41
2.2.3.4	X122 Digital inputs/outputs	42
2.2.3.5	X132 Digital inputs/outputs	44
2.2.3.6	X124 Electronics power supply.....	45
2.2.3.7	X126 PROFIBUS	46
2.2.3.8	PROFIBUS address switches.....	47
2.2.3.9	Serial interface (RS232) X140	48
2.2.3.10	Measuring sockets	48
2.2.3.11	Slot for the CompactFlash card	49
2.2.3.12	Description of the LEDs on the Control Unit CU320.....	50
2.2.4	Dimension drawing	53
2.2.5	Installation	54
2.2.6	Technical data.....	59
2.3	Control Unit CU320-2 DP.....	60
2.3.1	Description	60
2.3.2	Safety information	61
2.3.3	Interface description.....	62
2.3.3.1	Overview	62
2.3.3.2	Connection example	64
2.3.3.3	X100 - X103 DRIVE-CLiQ interface.....	65
2.3.3.4	X122 Digital inputs/outputs	66
2.3.3.5	X132 Digital inputs/outputs	68
2.3.3.6	X124 Electronics power supply.....	69
2.3.3.7	X126 PROFIBUS	70
2.3.3.8	PROFIBUS address switch.....	71
2.3.3.9	X127 LAN (Ethernet).....	72
2.3.3.10	X140 serial interface (RS232).....	73

2.3.3.11	Measuring sockets	73
2.3.3.12	Slot for the CompactFlash card	74
2.3.3.13	Description of the LEDs on the Control Unit CU320-2 DP	75
2.3.4	Dimension drawing	78
2.3.5	Installation	79
2.3.6	Technical data	85
3	Additional system components	87
3.1	Basic Operator Panel BOP20	87
3.1.1	Description	87
3.1.2	Interface description	87
3.1.3	Installation	90
3.1.4	Removal	92
3.2	Option Board: CAN Communication Board CBC10	93
3.2.1	Description	93
3.2.2	Safety information	93
3.2.3	Interface description	94
3.2.3.1	Overview	94
3.2.3.2	CAN bus interface X451	95
3.2.3.3	CAN bus interface X452	95
3.2.3.4	2-pin SMD DIL switch	96
3.2.3.5	Meaning of the LED	97
3.2.4	Installation	98
3.2.5	Technical data	99
3.3	Option Board: Communication Board Ethernet CBE20	99
3.3.1	Description	99
3.3.2	Safety information	99
3.3.3	Interface description	100
3.3.3.1	Overview	100
3.3.3.2	X1400 Ethernet interface	101
3.3.3.3	Meaning of the LEDs on the CBE20 Communication Board Ethernet	102
3.3.4	Installation	104
3.3.5	Technical specifications	105
3.4	Option Board: Terminal Board TB30	105
3.4.1	Description	105
3.4.2	Safety information	105
3.4.3	Interface description	106
3.4.3.1	Overview	106
3.4.3.2	Connection example	107
3.4.3.3	X424 power supply, digital outputs	108
3.4.3.4	X481 Digital inputs/outputs	109
3.4.3.5	X482 Analog inputs/outputs	110
3.4.4	Installation	111
3.4.5	Shield support	112
3.4.6	Technical data	113
3.5	Terminal Module TM15	113
3.5.1	Description	113
3.5.2	Safety information	113
3.5.3	Interface description	114
3.5.3.1	Overview	114
3.5.3.2	Connection example	115
3.5.3.3	X500 and X501 DRIVE-CLiQ interface	116
3.5.3.4	X524 Electronics power supply	116

3.5.3.5	X520 digital inputs/outputs	117
3.5.3.6	X521 digital inputs/outputs	118
3.5.3.7	X522 digital inputs/outputs	119
3.5.3.8	Meaning of the LEDs on the Terminal Module TM15	120
3.5.4	Dimension drawing	121
3.5.5	Installation	122
3.5.6	Protective conductor connection and shield support	123
3.5.7	Connector coding	124
3.5.8	Technical data	125
3.6	Terminal Module TM17	127
3.6.1	Description	127
3.7	Terminal Module TM31	128
3.7.1	Description	128
3.7.2	Safety information	128
3.7.3	Interface description	129
3.7.3.1	Overview	129
3.7.3.2	Connection example	131
3.7.3.3	X500 and X501 DRIVE-CLiQ interface	132
3.7.3.4	X524 Electronics power supply	132
3.7.3.5	Digital inputs X520	133
3.7.3.6	Digital inputs X530	134
3.7.3.7	Auxiliary voltage for the digital inputs X540	135
3.7.3.8	X521 analog inputs	136
3.7.3.9	S5 current/voltage changeover switch for analog inputs	136
3.7.3.10	X522 analog outputs/temperature sensor	137
3.7.3.11	X541 bidirectional digital inputs/outputs	138
3.7.3.12	Relay outputs X542	140
3.7.3.13	Meanings of the LED on the Terminal Module TM31	141
3.7.4	Dimension drawings	142
3.7.5	Installation	144
3.7.6	Protective conductor connection and shield support	145
3.7.7	Connector coding	146
3.7.8	Technical data	147
3.8	Terminal Module TM41	148
3.8.1	Description	148
3.8.2	Safety information	148
3.8.3	Interface description	149
3.8.3.1	Overview	149
3.8.3.2	Connection example	151
3.8.3.3	X500 and X501 DRIVE-CLiQ interface	152
3.8.3.4	X514 and X524 Power supply	152
3.8.3.5	Sensor interface X520	153
3.8.3.6	X521 Bidirectional digital inputs/outputs	154
3.8.3.7	X522 digital inputs / floating (isolated)	155
3.8.3.8	X523 Analog input	156
3.8.3.9	Meaning of the LEDs on the Terminal Module TM41	157
3.8.4	Dimension drawings	158
3.8.5	Installation	160
3.8.6	Protective conductor connection and shield support	161
3.8.7	Technical data	162
3.9	Terminal Module TM54F	163
3.9.1	Description	163
3.9.2	Safety information	164

3.9.3	Interface description	165
3.9.3.1	Overview	165
3.9.3.2	Connection example	166
3.9.3.3	X500 and X501 DRIVE-CLiQ interface	167
3.9.3.4	X514 power supply for digital outputs and sensors	167
3.9.3.5	X520 sensor power supply	168
3.9.3.6	X521 digital inputs + power supply with forced dormant error detection	168
3.9.3.7	X522 digital inputs	169
3.9.3.8	X523 digital outputs	170
3.9.3.9	X524 Electronics power supply	171
3.9.3.10	X525 digital outputs	172
3.9.3.11	X531 digital inputs + power supply with forced dormant error detection	173
3.9.3.12	X532 digital inputs	174
3.9.3.13	X533 digital outputs	175
3.9.3.14	X535 digital outputs	176
3.9.3.15	Meaning of the LEDs on the Terminal Module TM54F	177
3.9.4	Dimension drawing	179
3.9.5	Installation	180
3.9.6	Protective conductor connection and shield support	181
3.9.7	Technical data	182
3.10	Terminal Module TM120	183
3.10.1	Description	183
3.10.2	Safety information	183
3.10.3	Interface description	184
3.10.3.1	Overview	184
3.10.3.2	Connection examples	185
3.10.3.3	X500 and X501 DRIVE-CLiQ interface	186
3.10.3.4	X524 Electronics power supply	187
3.10.3.5	X521 temperature sensor input	188
3.10.3.6	Meaning of the LEDs on the Terminal Module TM120	190
3.10.4	Dimension drawing	191
3.10.5	Installation	191
3.10.6	Protective conductor connection and shield support	193
3.10.7	Technical data	194
3.11	DRIVE-CLiQ Hub Module DMC20	195
3.11.1	Description	195
3.11.2	Safety information	195
3.11.3	Interface description	196
3.11.3.1	Overview	196
3.11.3.2	X500 - X505 DRIVE-CLiQ interfaces	197
3.11.3.3	X524 Electronics power supply	197
3.11.3.4	Description of the LEDs on the DRIVE-CLiQ Hub Module DMC20	198
3.11.4	Dimension drawing	199
3.11.5	Installation	199
3.11.6	Technical data	200
3.12	DRIVE-CLiQ Hub Module External DME20	201
3.12.1	Description	201
3.12.2	Safety information	201
3.12.3	Interface description	202
3.12.3.1	Overview	202
3.12.3.2	X500 - X505 DRIVE-CLiQ interfaces	203
3.12.3.3	X524 Electronics power supply	204
3.12.4	Dimension drawing	205
3.12.5	Installation	206

3.12.6	Technical data.....	207
3.12.7	Specifications for use with UL approval.....	207
3.13	Voltage Sensing Module VSM10.....	209
3.13.1	Description.....	209
3.13.2	Safety information.....	210
3.13.3	Interface description.....	211
3.13.3.1	Overview.....	211
3.13.3.2	Connection example.....	212
3.13.3.3	X500 DRIVE-CLiQ interface.....	213
3.13.3.4	X524 Electronics power supply.....	214
3.13.3.5	X520 analog inputs/temperature sensor.....	214
3.13.3.6	X521 three-phase line supply voltage sensing up to 100 V (phase-to-phase).....	215
3.13.3.7	X522 three-phase line supply voltage sensing up to 690 V (phase-to-phase).....	215
3.13.3.8	Meanings of the LEDs on the Voltage Sensing Module VSM10.....	216
3.13.4	Dimension drawing.....	217
3.13.5	Protective conductor connection and shield support.....	218
3.13.6	Technical data.....	219
4	Encoder system connection.....	221
4.1	Introduction.....	221
4.2	Overview of Sensor Modules.....	222
4.3	Sensor Module Cabinet-Mounted SMC10.....	225
4.3.1	Description.....	225
4.3.2	Safety information.....	225
4.3.3	Interface description.....	226
4.3.3.1	Overview.....	226
4.3.3.2	Connection example.....	228
4.3.3.3	DRIVE-CLiQ interface X500.....	228
4.3.3.4	X520 encoder system interface.....	229
4.3.3.5	X524 Electronics power supply.....	230
4.3.3.6	Meaning of LEDs on the Sensor Module Cabinet-Mounted SMC10.....	230
4.3.4	Dimension drawings.....	231
4.3.5	Installation.....	233
4.3.6	Technical data.....	234
4.4	Sensor Module Cabinet-Mounted SMC20.....	236
4.4.1	Description.....	236
4.4.2	Safety information.....	236
4.4.3	Interface description.....	237
4.4.3.1	Overview.....	237
4.4.3.2	Connection example.....	238
4.4.3.3	DRIVE-CLiQ interface X500.....	238
4.4.3.4	X520 encoder system interface.....	239
4.4.3.5	X524 Electronics power supply.....	240
4.4.3.6	Meaning of LEDs on the Sensor Module Cabinet-Mounted SMC20.....	240
4.4.4	Dimension drawing.....	241
4.4.5	Installation.....	242
4.4.6	Technical data.....	243
4.5	Sensor Module Cabinet-Mounted SMC30.....	244
4.5.1	Description.....	244
4.5.2	Safety information.....	244
4.5.3	Interface description.....	245
4.5.3.1	Overview.....	245
4.5.3.2	Connection examples.....	246

4.5.3.3	DRIVE-CLiQ interface X500.....	248
4.5.3.4	X520 encoder system interface	249
4.5.3.5	X521 / X531 alternative encoder system interface	250
4.5.3.6	X524 Electronics power supply	251
4.5.3.7	Meaning of LEDs on the Sensor Module Cabinet-Mounted SMC30	252
4.5.4	Dimension drawing.....	253
4.5.5	Installation	254
4.5.6	Protective conductor connection and shield support	255
4.5.7	Technical data.....	256
4.6	Sensor Module External SME20.....	261
4.6.1	Description	261
4.6.2	Safety Information	261
4.6.3	Interface description	262
4.6.3.1	Overview	262
4.6.3.2	Connection example	262
4.6.3.3	DRIVE-CLiQ interface.....	263
4.6.3.4	Encoder system interface.....	264
4.6.4	Dimension drawings.....	265
4.6.5	Installation	266
4.6.6	Technical data.....	267
4.7	Sensor Module External SME25.....	269
4.7.1	Description	269
4.7.2	Interface description	269
4.7.2.1	Overview	269
4.7.2.2	Connection example	270
4.7.2.3	DRIVE-CLiQ interface.....	270
4.7.2.4	Encoder system interface.....	271
4.7.3	Dimension drawings.....	272
4.7.4	Installation	273
4.7.5	Technical data.....	274
4.8	Sensor Module External SME120.....	276
4.8.1	Description	276
4.8.2	Safety information	277
4.8.3	Interface description	278
4.8.3.1	Overview	278
4.8.3.2	Connection examples.....	279
4.8.3.3	X500 DRIVE-CLiQ interface.....	284
4.8.3.4	X100 encoder system interface	284
4.8.3.5	X200 thermistor sensor input	285
4.8.3.6	X300 Hall sensor input.....	285
4.8.4	Dimension drawings.....	286
4.8.5	Installation	287
4.8.6	Technical data.....	288
4.9	Sensor Module External SME125.....	290
4.9.1	Description	290
4.9.2	Safety information	291
4.9.3	Interface description	292
4.9.3.1	Overview	292
4.9.3.2	Connection examples.....	293
4.9.3.3	X500 DRIVE-CLiQ interface.....	298
4.9.3.4	X100 encoder system interface	299
4.9.3.5	X200 thermistor sensor input	300
4.9.4	Dimension drawings.....	300

4.9.5	Installation	301
4.9.6	Technical data	302
4.10	DRIVE-CLiQ encoder	304
4.10.1	Description	304
4.10.2	Safety information	304
4.10.3	Interface description	305
4.10.3.1	Overview	305
4.10.3.2	DRIVE-CLiQ interface	305
4.10.4	Dimension drawings	306
4.10.5	Installation	308
4.10.6	Technical data	310
5	Information on electromagnetic compatibility (EMC)	311
5.1	Cabinet design and EMC Booksize	311
A	Appendix A	313
A.1	Connectable conductor cross-sections for spring-loaded terminals	313
A.2	Connectable conductor cross-sections for screw terminals	314
B	Appendix B	315
B.1	List of abbreviations	315
C	Fax template	327
	Index	329

System overview

1.1 Field of application

SINAMICS is the new range of drives from Siemens designed for mechanical and plant engineering applications. SINAMICS offers solutions for all drive tasks:

- Simple pump and fan applications in the process industry.
- Complex individual drives in centrifuges, presses, extruders, elevators, as well as conveyor and transport systems.
- Drive line-ups in textile, plastic film, and paper machines, as well as in rolling mill plants.
- Highly dynamic servo drives for machine tools, as well as packaging and printing machines.

Depending on the application, the SINAMICS range offers the ideal version for any drive task.

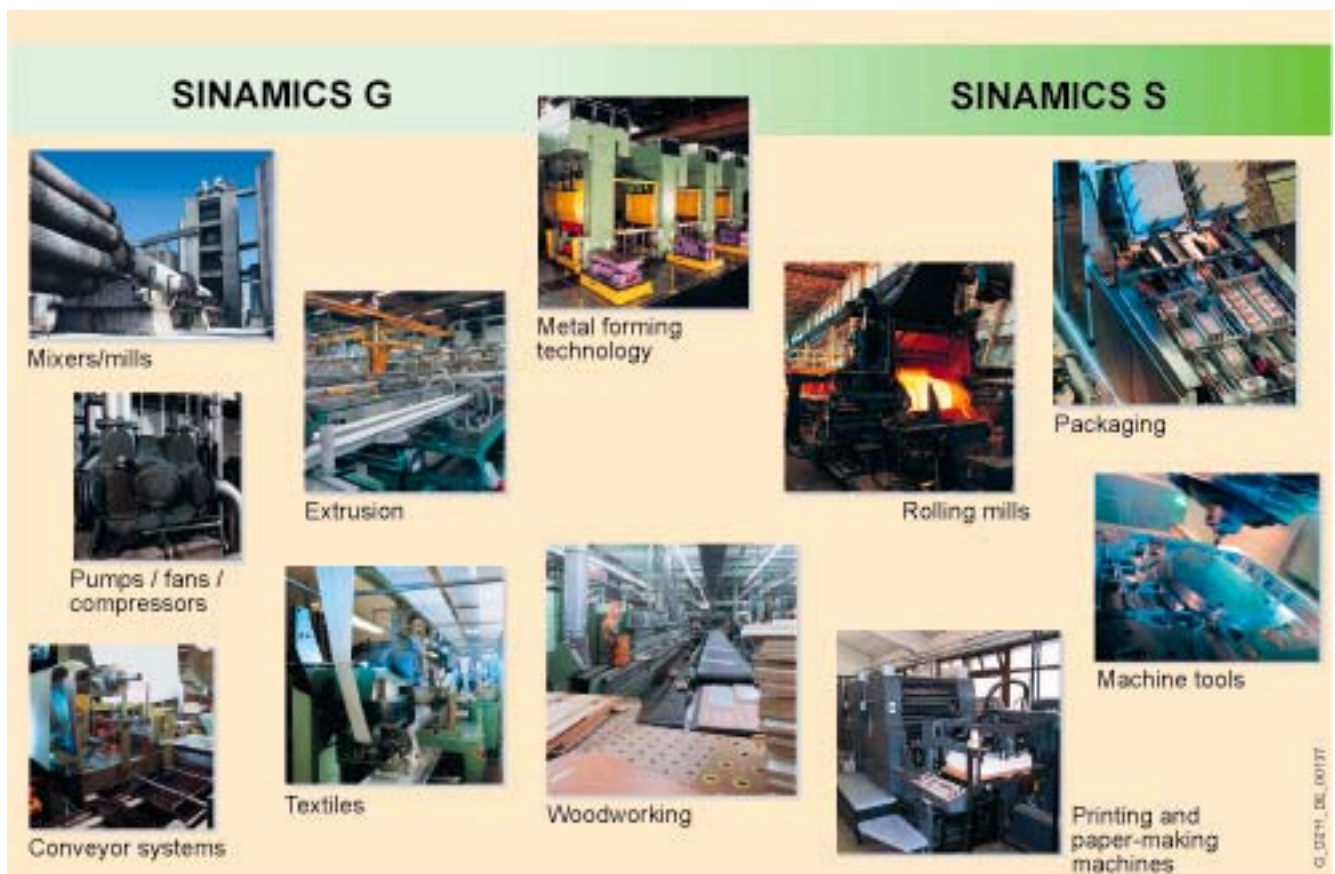

Figure 1-1 SINAMICS applications

1.2 Platform Concept and Totally Integrated Automation

All SINAMICS versions are based on a platform concept. Joint hardware and software components, as well as standardized tools for design, configuration, and commissioning tasks ensure high-level integration across all components. SINAMICS handles a wide variety of drive tasks with no system gaps. The different SINAMICS versions can be easily combined with each other.

SINAMICS is part of the Siemens "Totally Integrated Automation" concept. Integrated SINAMICS systems covering configuration, data storage, and communication at automation level, ensure low-maintenance solutions with SIMATIC, SIMOTION, and SINUMERIK.

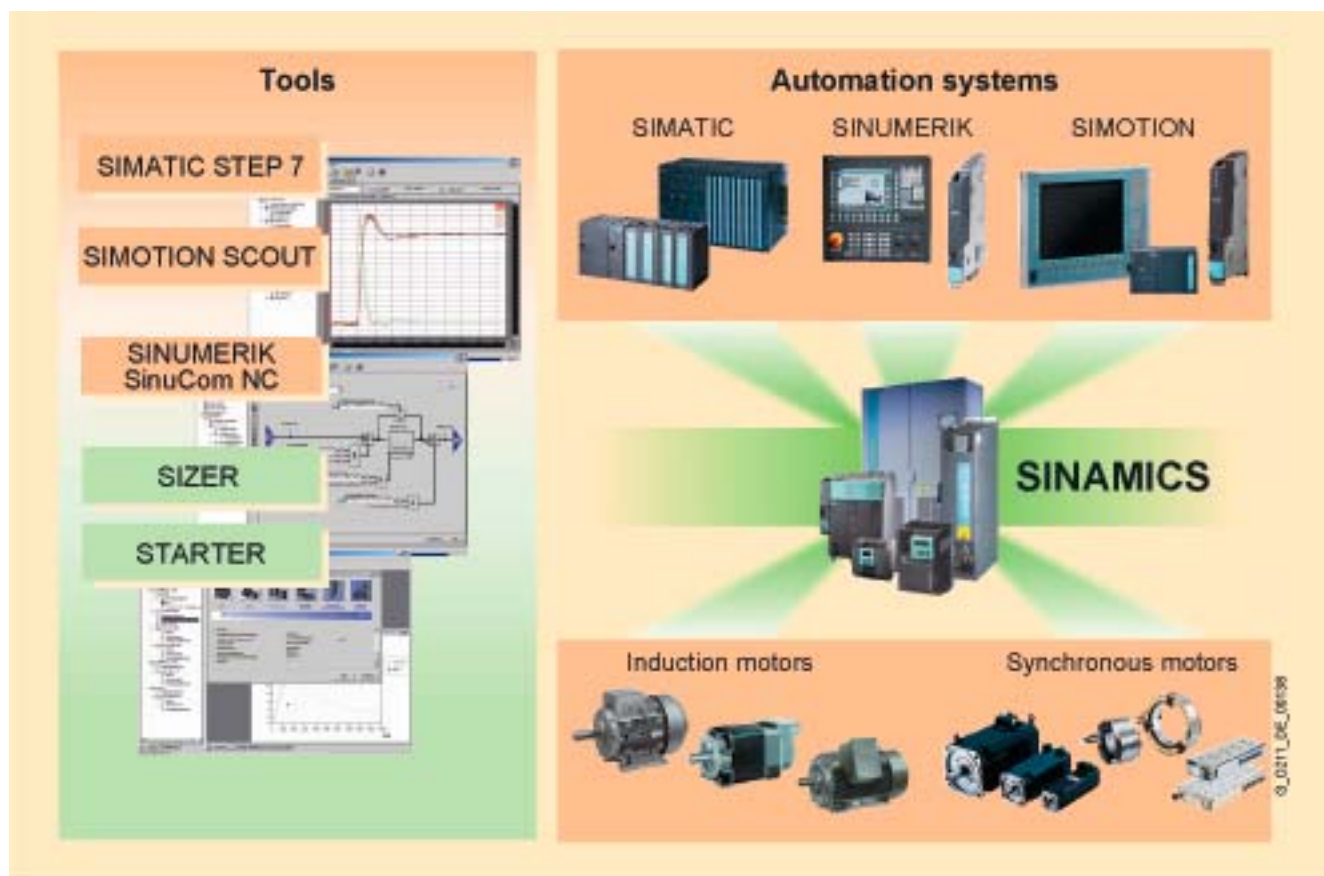

Figure 1-2 SINAMICS as part of the Siemens modular automation system

1.3 Introduction

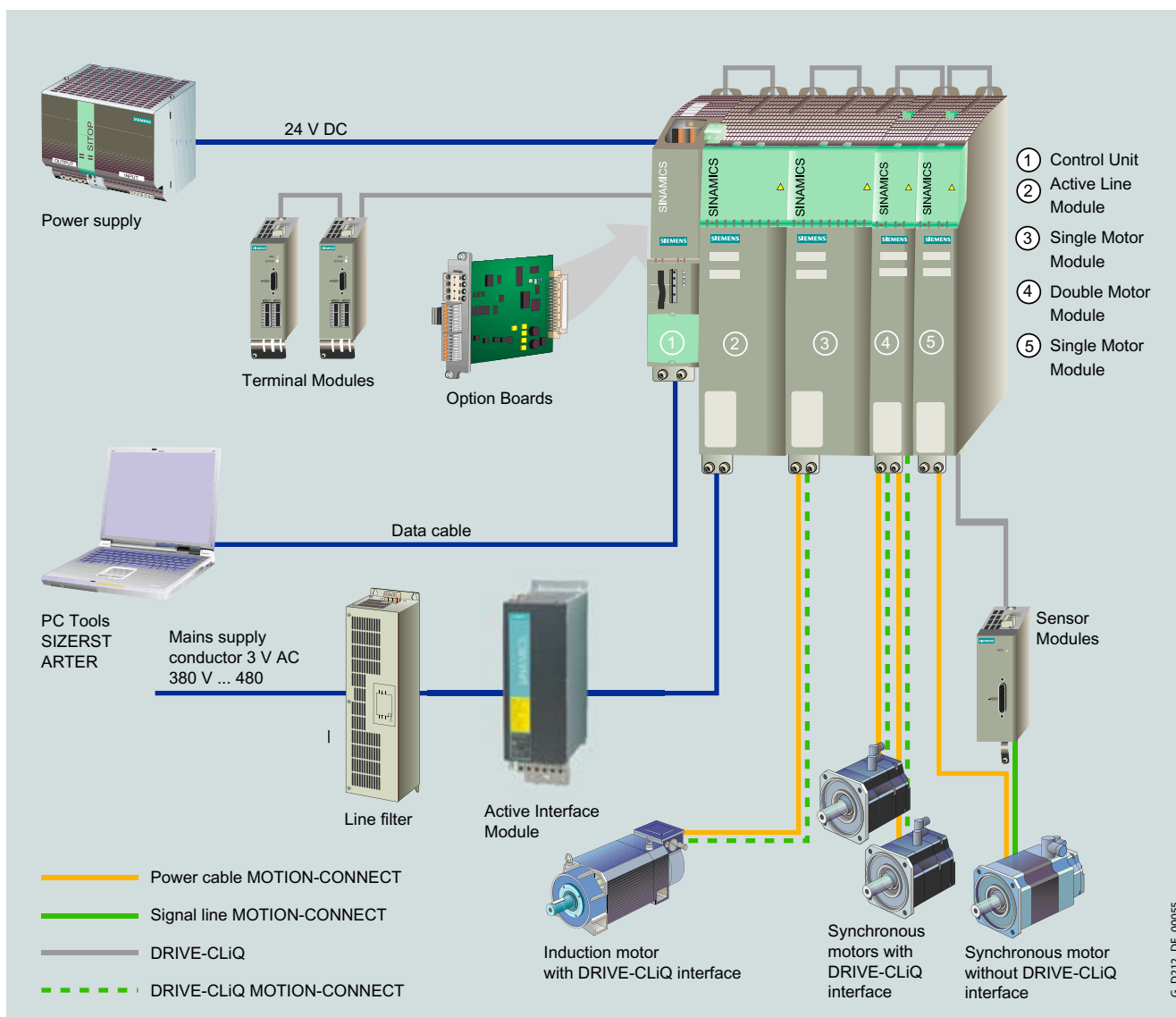

Figure 1-3 SINAMICS S120 system overview

Modular system for sophisticated drive tasks

SINAMICS S120 solves complex drive tasks for a wide range of industrial applications and is, therefore, designed as a modular system. Users can choose from many different harmonized components and functions to create a solution that best meets their requirements. SIZER, a high-performance engineering tool, makes it easier to choose and determine the optimum drive configuration.

SINAMICS S120 is supplemented by a wide range of motors. Whether torque, synchronous or induction motors, whether rotating or linear motors, all of these motors are optimally supported by SINAMICS S120.

Drive for multi-axis applications

The trend towards separate axes in mechanical engineering is growing all the time. Where possible, central drives are being replaced by electronically coordinated servo drives. These require drives with a connected DC link, which allows cost-saving energy exchange between braking and driving axes.

SINAMICS S120 features infeeds and inverters that cover a broad power range, are designed for seamless integration, and enable space-saving, multi-axis drive configurations.

New system architecture with a central Control Unit

Electronically coordinated individual drives work together to perform your drive tasks. Higher-level controllers operate the drives to achieve the required coordinated movement. This requires cyclic data exchange between the control and all the drives. This exchange always had to take place via a field bus, which required a great deal of time and effort for installation and configuration. SINAMICS S120 takes a different approach. A central Control Unit controls the drive for all connected axes and also establishes the technological links between the axes. Since all the required data is stored in the central Control Unit, it does not need to be transferred. Inter-axis connections can be established within a component and easily configured in the STARTER commissioning tool using a mouse.

Simple technological tasks can be carried out by the SINAMICS S120 Control Unit itself. For complex numerical or motion-control tasks, high-performance SINUMERIK or SIMOTION D modules are used instead.

DRIVE-CLiQ – the digital interface between SINAMICS components

The SINAMICS S120 components, including the motors and encoders, are interconnected via a joint serial interface called DRIVE-CLiQ. The standardized cables and connectors reduce the variety of different parts and cut storage costs.

Encoder evaluations for converting standard encoder signals to DRIVE-CLiQ are available for third-party motors or retrofit applications.

Electronic rating plates in all components

All SINAMICS S120 components have an electronic rating plate. This electronic rating plate contains all the relevant technical data about that particular component. In the motors, for example, this data includes the parameters of the electric equivalent circuit diagram and characteristic values for the built-in motor encoder. The Control Unit records this data automatically via DRIVE-CLiQ so that it does not need to be entered during commissioning or when the equipment is replaced.

In addition to the technical data, the rating plate includes logistical data (manufacturer ID, order number, and globally unique ID). Since this data can be called up electronically on site or remotely, all the components used in a machine can always be individually identified, which helps simplify servicing.

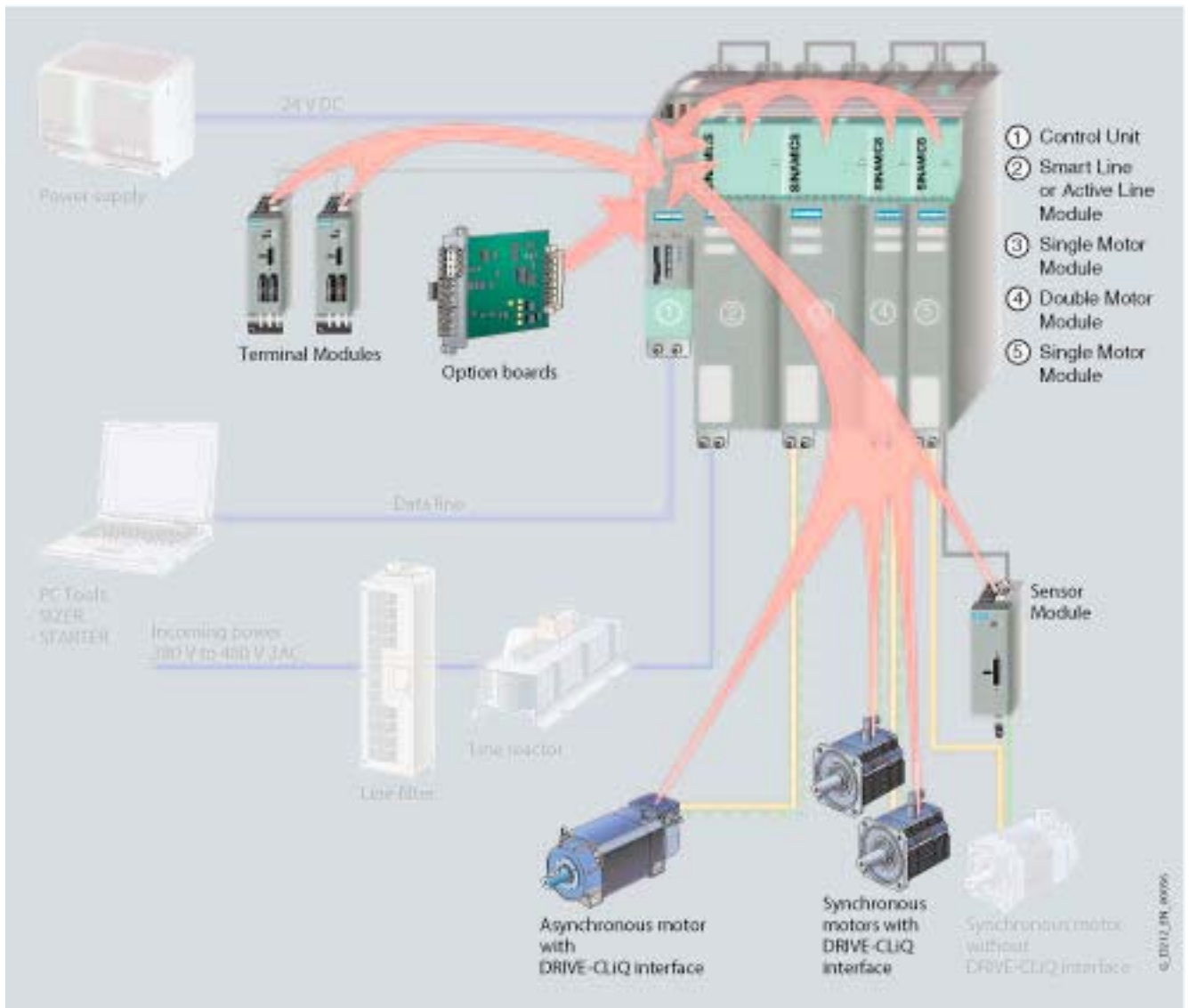

Figure 1-4 The electronic rating plate for SINAMICS S120

1.4 SINAMICS S120 components

The following system components are available:

- Line-side power components, such as fuses, contactors, reactors, and filters for switching the power supply and meeting EMC requirements.
- Line Modules, which supply power centrally to the DC link.
- DC-link components (optional), which stabilize the DC-link voltage.
- Motor Modules, which act as inverters, receive power from the DC link, and supply the connected motors.

To carry out the required functions, SINAMICS S120 is equipped with:

- A Control Unit that carries out all drive and technological functions across all axes.
- Supplementary system components that enhance functionality and offer different interfaces for encoders and process signals.

SINAMICS S120 components were developed for installation in cabinets. They have the following features and characteristics:

- Easy to handle, simple installation and wiring
- Practical connection system, cable routing in accordance with EMC requirements
- Standardized design, seamless integration

Booksize format

Booksize format units are optimized for multi-axis applications and are mounted adjacent to one another. The connection for the shared voltage-source DC link is an integral feature.

The booksize format offers various cooling options:

- Internal air cooling
- External air cooling
- Cold plate cooling
- Liquid Cooled

Booksize compact format

The booksize compact format combines all benefits of the booksize format and provides the same performance with an even smaller overall height and an extended overload capability. The booksize compact format is thus particularly well suited for integration into machines with high dynamic requirements and confined installation conditions.

The booksize compact format offers the following cooling options:

- Internal air cooling
- Cold plate cooling

Power units

Line Modules

Convert the three-phase supply into a DC voltage for the DC link.

- **Basic Line Modules**
Basic Line Modules generate a non-regulated DC link voltage and are not capable of regenerative feedback.
- **Smart Line Modules**
The Smart Line Modules generate a non-regulated DC link voltage and are capable of regenerative feedback.
- **Active Line Modules**
The Active Line Modules generate a regulated DC link voltage and are capable of regenerative feedback.

Motor Modules

Convert energy from the DC link for the connected motors with variable voltage and variable frequency.

1.5 System data

Technical data

Unless explicitly specified otherwise, the following technical data are valid for components of the SINAMICS S120 booksize drive system.

Electrical specifications	
Electronics power supply	24 V DC -15/+20%, protective extra-low voltage DVC A (PELV)
Line connection voltage	3-ph. 380 V to 480 V AC $\pm 10\%$ (-15% < 1 min)
Line frequency	47 Hz to 63 Hz
Radio interference suppression acc. to EN 61800-3	Category C3 (standard) Category C2 (option) for systems implemented in conformance with the EC Declaration of Conformity for EMC and with the EMC Installation Guidelines, Order No.: 6FC5297-□AD30-0AP□
Overvoltage category	III acc. to EN 60664-1
Degree of contamination	2 acc. to EN 60664-1

Environmental conditions	
The Safety Integrated safety function: The components must be protected against conductive pollution (e.g. by installing them in a cabinet with degree of protection IP54B acc. to EN 60529). Provided that conductive pollution can be prevented at the installation site, the degree of protection for the cabinet can be decreased accordingly.	
Degree of protection	IP20 or IPXXB acc. to EN 60529, open type acc. to UL 508
Degree of protection for SME20/25/120/125 and DME20	IP67, with mounted connectors or protective caps.
Protective class, line supply circuits Protective class, electronic circuits	I (with protective conductor connection) III (safety extra-low voltage DVC A /PELV) acc. to EN 61800-5-1
Permissible ambient temperature in the cabinet during operation	0 °C to +55 °C up to 2000 m above sea level. Above an altitude of 2000 m, the max. ambient temperature decreases by 3.5 K every 500 m. Installation altitude: max. 4000 m above sea level
Chemically active substances <ul style="list-style-type: none"> Long-term storage in the transport packaging Transport in the transport packaging Operation 	Class 1C2 acc. to EN 60721-3-1 Class 2C2 acc. to EN 60721-3-2 Class 3C2 acc. to EN 60721-3-3
Biological environmental conditions <ul style="list-style-type: none"> Long-term storage in the transport packaging Transport in the transport packaging Operation 	Class 1B1 acc. to EN 60721-3-1 Class 2B1 acc. to EN 60721-3-2 Class 3B1 acc. to EN 60721-3-3

Environmental conditions	
<p>Vibratory load</p> <ul style="list-style-type: none"> • Long-term storage in the transport packaging • Transport in the transport packaging • Operation (except SME20/25/120/125) <p>Test values for SME20/25/120/125 and DME20</p> <ul style="list-style-type: none"> • Operation 	<p>Class 1M2 acc. to EN 60721-3-1 Class 2M3 acc. to EN 60721-3-2 Test values: Frequency range: 10 Hz to 58 Hz With constant deflection = 0.075 mm Frequency range: 58 Hz to 200 Hz With constant acceleration 1 g</p> <p>Frequency range: 10 Hz to 58 Hz With constant deflection = 0.37 mm Frequency range: 58 Hz to 200 Hz With constant acceleration 5 g</p>
<p>Shock stressing</p> <ul style="list-style-type: none"> • Long-term storage in the transport packaging • Transport in the transport packaging • Operation (except SME20/25/120/125) <p>Test values for SME20/25/120/125 and DME20</p> <ul style="list-style-type: none"> • Operation 	<p>Class 1M2 acc. to EN 60721-3-1 Class 2M3 acc. to EN 60721-3-2 Test values: 15 g / 11 ms</p> <p>Test values: 25 g / 6 ms</p>
<p>Climatic ambient conditions</p> <ul style="list-style-type: none"> • Long-term storage in the transport packaging • Transport in the transport packaging • Operation <p>SME20/25/120/125 and DME20</p> <ul style="list-style-type: none"> • Operation 	<p>Class 1K4 acc. to EN 60721-3-1 Temperature -25 °C to +55 °C Class 2K4 acc. to EN 60721-3-2 Temperature -40 °C to +70 °C Class 3K3 acc. to EN 60721-3-3 Temperature +0 °C to +40 °C Relative / absolute air humidity 5 % to 90 % / $\leq 25 \text{ g/m}^3$ Oil mist, salt mist, formation of ice, moisture condensation, dripping, spray, splashing and water jets not permissible</p> <p>Temperature +0 °C to +55 °C Air humidity: $\geq 5 \%$ to $\leq 65 \%$ annual average $\leq 85 \%$ for max. 2 months / year moisture condensation and the formation of ice not permissible</p>

Certificates	
Declarations of Conformity	CE (Low-Voltage and EMC Directives)
Approbation	cULus

1.6 Standards

Note

The standards listed in the table below are non-binding and do not in any way claim to be complete. The standards listed do not represent a guaranteed property of the product.

Only the statements made in the Declaration of Conformity shall be deemed binding.

Table 1- 1 Fundamental, application-relevant standards in succession: EN, IEC/ISO, DIN, VDE

Standards*	Title
EN 1037 ISO 14118 DIN EN 1037	Safety of machinery; avoiding unexpected starting
EN ISO 9001 ISO 9001 DIN EN ISO 9001	Quality management systems - requirements
EN ISO 12100-x ISO 12100-x DIN EN ISO 12100-x	Safety of Machinery; General Design Guidelines; Part 1: Basic terminology, methodology Part 2: Technical Principles and Specifications
EN ISO 13849-x ISO 13849-x DIN EN ISO 13849-x	Safety of machinery; safety-related parts of control systems; Part 1: General basic design principles Part 2: Validation
EN ISO 14121-1 ISO 14121-1 DIN EN ISO 14121-1	Safety of Machinery - Risk Assessment; Part 1: Guidelines
EN 55011 CISPR 11 DIN EN 55011 VDE 0875-11	Industrial, scientific and medical high-frequency devices (ISM devices) - radio interference - limit values and measuring techniques
EN 60146-1-1 IEC 60146-1-1 DIN EN 60146-1-1 VDE 0558-11	Semiconductor converters; general requirements and line-commutated converters; Part 1-1: Defining the basic requirements
EN 60204-1 IEC 60204-1 DIN EN 60204-1 VDE 0113-1	Electrical equipment of machines; Part 1: General definitions
EN 60228 IEC 60228 DIN EN 60228 VDE0295	Conductors for cables and insulated leads
EN 60269-1 IEC 60269-1 DIN EN 60269-1 VDE 0636-1	Low-voltage fuses; Part 1: General requirements
IEC 60287-1 to -3	Cables - Calculation of the current carrying capacity Part 1: Current carrying capacity equations (100 % load factor) and calculating the losses Part 2: Thermal resistance - Part 3: Main sections for operating conditions

Standards*	Title
HD 60364-x-x IEC 60364-x-x DIN VDE 0100-x-x VDE 0100-x-x	Erection of power installations with nominal voltages up to 1000 V; Part 200: Definitions Part 410: Protection for safety, protection against electric shock Part 420: Protection for safety, protection against thermal effects Part 430: Protection of cables and conductors for over-current Part 450: Protection for safety, protection against undervoltage Part 470: Protection for safety; use of protection for safety Part 5xx: Selecting and erecting electrical equipment Part 520: Wiring systems Part 540: Earthing, protective conductor, potential bonding conductor Part 560: Electrical equipment for safety purposes
EN 60439 IEC 60439 DIN EN 60439 VDE 0660-500	Low-voltage switchgear assemblies; Part 1: Type-tested and partially type-tested assemblies
EN 60529 IEC 60529 DIN EN 60529 VDE 0470-1	Degrees of protection provided by enclosures (IP code)
EN 60721-3-x IEC 60721-3-x DIN EN 60721-3-x	Classification of environmental conditions Part 3-0: Classification of environmental parameters and their severities; Introduction Part 3-1: Classification of environmental parameters and their severities; Long-term storage Part 3-2: Classification of environmental parameters and their severities; Transport Part 3-3: Classification of environmental parameters and their severities; stationary use, weather protected
EN 60947-x-x IEC 60947 -x-x DIN EN 60947-x-x VDE 0660-x	Low-voltage switchgear
EN 61000-6-x IEC 61000-6-x DIN EN 61000-6-x VDE 0839-6-x	Electromagnetic compatibility (EMC) Part 6-1: Generic standard; Immunity for residential, commercial and light-industrial environments Part 6-2: Generic standards; Immunity for industrial environments Part 6-3: Generic standards; Generic standard emission for residential, commercial and light-industrial environments Part 6-4: Generic standards; Generic standard noise emission for industrial environments
EN 61140 IEC 61140 DIN EN 61140 VDE 0140-1	Protection against electric shock; Common aspects for installation and equipment
EN 61800-2 IEC 61800-2 DIN EN 61800-2 VDE 0160-102	Adjustable-speed electrical power drive systems; Part 2: General requirements - Rating specifications for low-voltage adjustable frequency a.c. power drive systems
EN 61800-3 IEC 61800-3 DIN EN 61800-3 VDE 0160-103	Adjustable-speed electrical power drive systems; Part 3: EMC - Requirements and specific test methods
EN 61800-5-x IEC 61800-5-x DIN EN 61800-5-x VDE 0160-105-x	Adjustable-speed electrical power drive systems; Part 5: Safety requirements; Main section 1: Electrical, thermal and energy requirements Main section 2: Functional safety requirements

System overview

1.6 Standards

Standards*	Title
EN 62061 IEC 62061 DIN EN 62061 VDE 0113-50	Safety of machinery; Functional safety of safety-related electrical, electronic and programmable electronic control systems
UL 50 CSA C22.2 No. 94.1	Enclosures for Electrical Equipment
UL 508 CSA C22.2 No. 142	Industrial Control Equipment Process Control Equipment
UL 508C CSA C22.2 No. 14	Power Conversion Equipment Industrial Control Equipment

* The technical requirements in the standards listed are not necessarily identical.

Control Units

2.1 Introduction

Description

Control Units CU320 and CU320-2 DP of the SINAMICS S system are designed for use with several drives.

The number of variable-speed drives depends on:

- The required performance
- The required special functions
- The required operating mode (servo, vector, or V/f).

The software and the parameters are stored on a plug-in CompactFlash card.

The option slot is used to expand the number of terminals or adapt to other communication interfaces (to the higher-level control).

Compatible firmware versions:

- CU320 up to and including V2.6
- CU320-2 DP V4.3 or higher

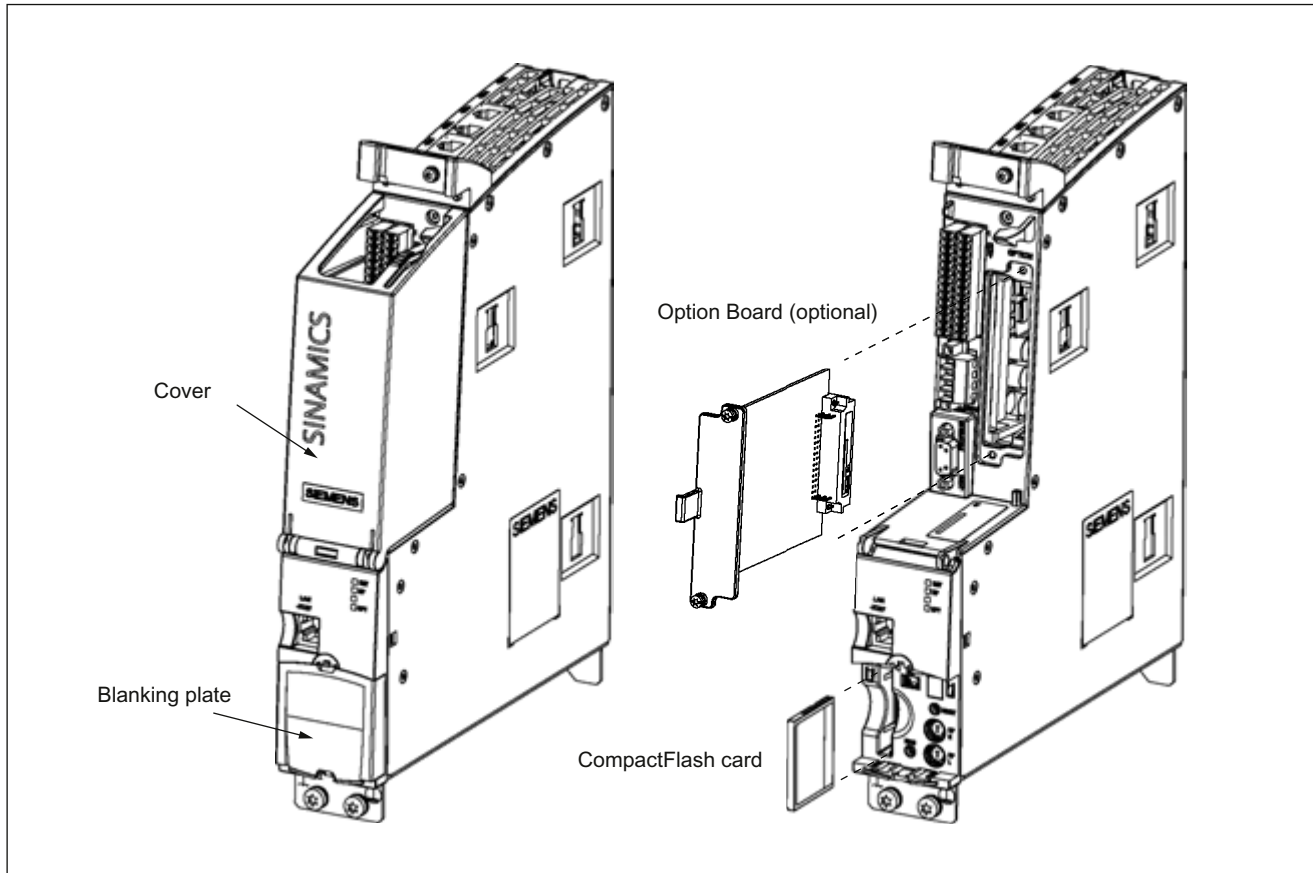

Figure 2-1 Overview, Control Unit CU320-2 DP

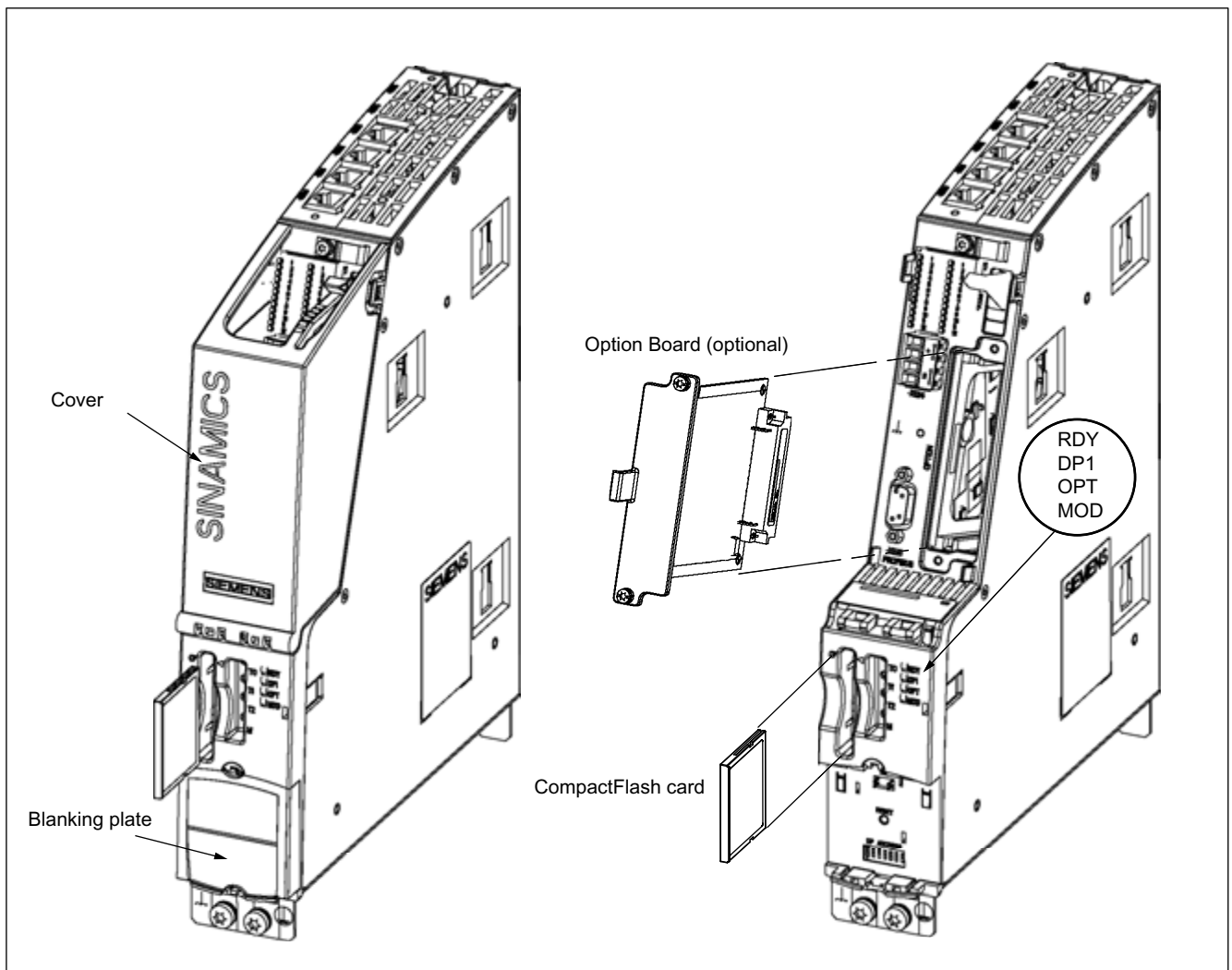

Figure 2-2 Overview, Control Unit CU320

Note

The Control Unit, the option board, and the CompactFlash card must be ordered separately.

Note

A CompactFlash card with firmware version 4.3 can only run on a CU320-2 DP. Older CompactFlash cards with firmware version 2.x can only run on a CU320.

If your application requires more than one Control Unit, the number can be increased accordingly. The Control Units are then interconnected via PROFIBUS, for example.

A Control Unit communicates with the associated components (Motor Modules, Line Modules, Sensor Modules, Terminal Modules, and so on) via the system-internal DRIVE-CLiQ interface.

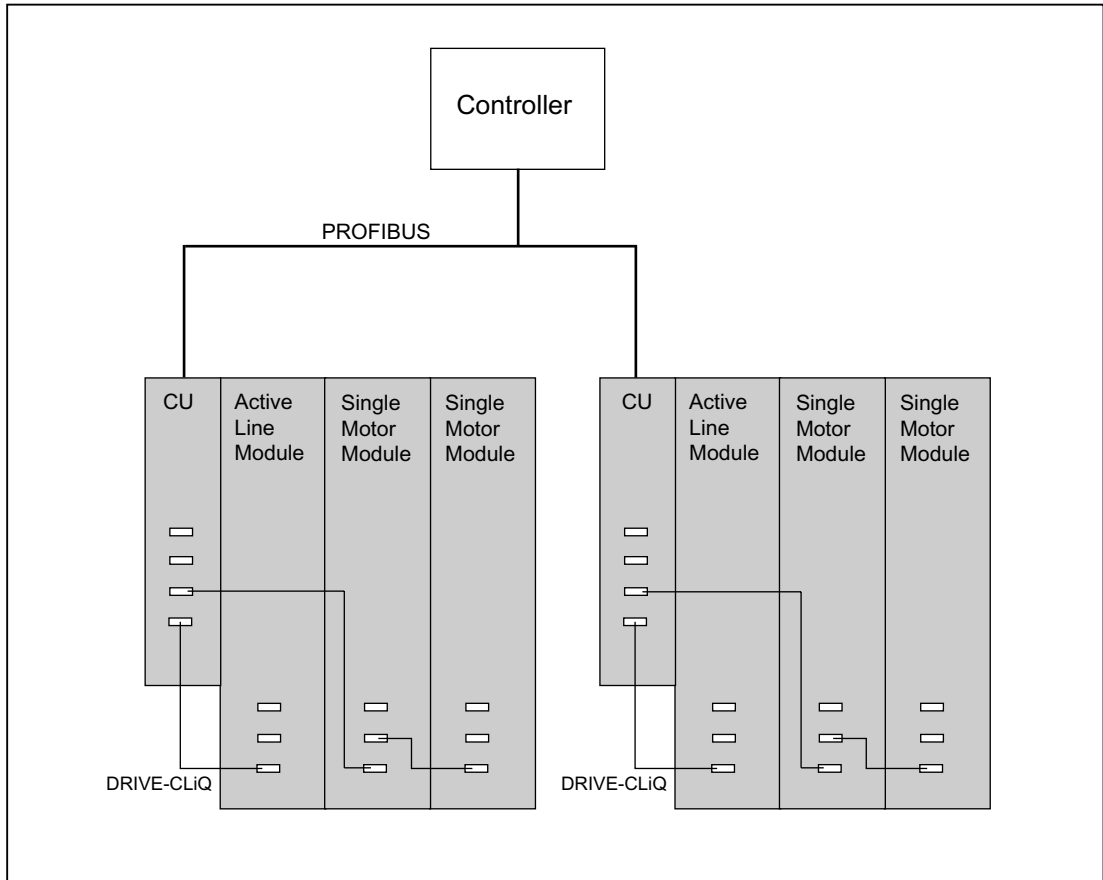

Figure 2-3 Sample configuration

2.2 Control Unit CU320

2.2.1 Description

The Control Unit 320 is a central control module in which the closed-loop and open-loop functions are implemented for one or more Line Modules and/or Motor Modules. It can be used with firmware versions up to and including 2.6.

The CU320 contains the following interfaces:

Table 2- 1 Overview of the CU320 interfaces

Type	Quantity
Digital inputs	8
Digital inputs/outputs	8
DRIVE-CLiQ interfaces	4
PROFIBUS interface	1
Serial interface (RS232)	1
Option slot	1
Measuring sockets	3

2.2.2 Safety information

 WARNING
The ventilation spaces of 80 mm above and below the component must be observed.

 CAUTION
A potential bonding conductor with a cross-section of at least 25 mm ² must be used between components in a system that are located at a distance from each other. If a potential bonding conductor is not used, high leakage currents that could destroy the Control Unit or other PROFIBUS nodes can be conducted via the PROFIBUS cable.

CAUTION
The CompactFlash card may only be inserted or removed when the Control Unit is in a voltage-free state; doing this during operation instead could result in a loss of data and, where applicable, a plant standstill.

CAUTION
The CompactFlash card is an electrostatic sensitive component. ESD regulations must be observed when inserting and removing the card.

CAUTION
The Option Board should only be inserted and removed when the Control Unit and Option Board are at zero current.

2.2.3 Interface description

2.2.3.1 Overview

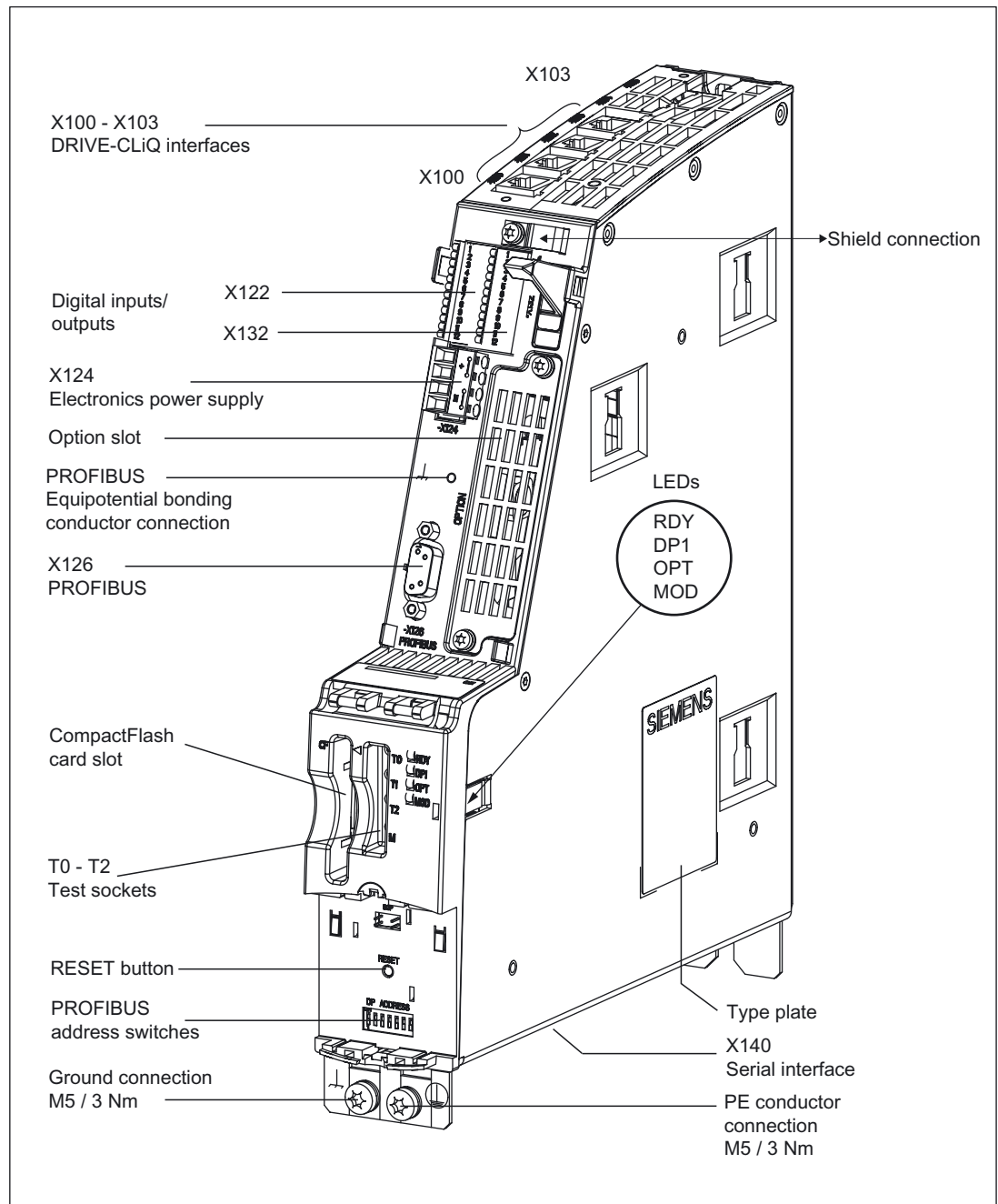

Figure 2-4 Interface description of the CU320 (covers removed)

2.2.3.2 Connection example

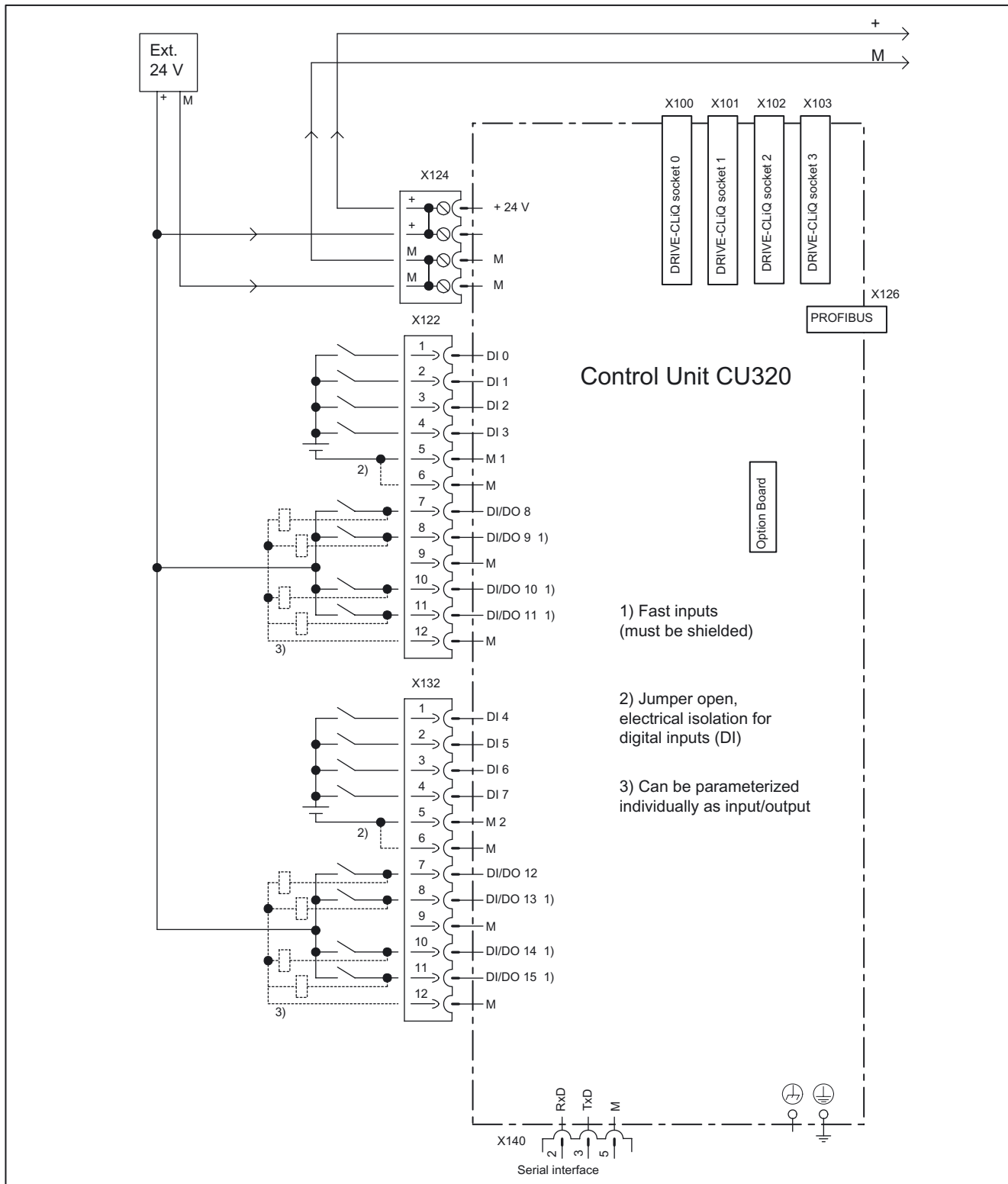
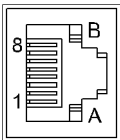

Figure 2-5 Connection example of CU320

2.2.3.3 X100 - X103 DRIVE-CLiQ interfaces

Table 2- 2 DRIVE-CLiQ interface

	Pin	Signal name	Technical specifications	
	1	TXP	Transmit data +	
	2	TXN	Transmit data -	
	3	RXP	Receive data +	
	4	Reserved, do not use		
	5	Reserved, do not use		
	6	RXN	Receive data -	
	7	Reserved, do not use		
	8	Reserved, do not use		
	A	+ (24 V)	Power supply	
	B	M (0 V)	Electronics ground	
	Connector type: RJ45 socket; blanking plate for DRIVE-CLiQ interface included in the scope of delivery; blanking plate (50 pieces) order number: 6SL3066-4CA00-0AA0			

2.2.3.4 X122 Digital inputs/outputs

Table 2- 3 Terminal block X122

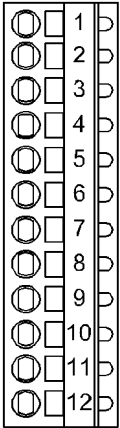
	Terminal	Designation ¹⁾	Technical specifications
	1	DI 0	Voltage: -3 V to +30 VDC Typical current consumption: 10 mA at 24 V Electrical isolation: The reference potential is terminal M1
	2	DI 1	
	3	DI 2	
	4	DI 3	
	5	M1	Level (incl. ripple) High level: 15 V to 30 V Low level: -3 V to +5 V
	6	M	
	7	DI/DO 8	As input: Voltage: -3 V to +30 VDC Typical current consumption: 10 mA at 24 V Level (incl. ripple) High level: 15 V to 30 V Low level: -3 V to +5 V Input delay (typ.): For "0" → "1": 50 μs For "1" → "0": 150 μs As output: Voltage: 24 V DC Max. load current per output: 500 mA Continued-short-circuit-proof Output delay (typ./max.): ³⁾ For "0" → "1": 150 μs/400 μs For "1" → "0": 75 μs/100 μs Switching frequency: For resistive load: Max. 100 Hz For inductive load: Max. 0.5 Hz For lamp load: Max. 10 Hz Maximum lamp load: 5 W
	8	DI/DO 9	
	9	M	
	10	DI/DO 10	
	11	DI/DO 11	
	12	M	DI/DO 8: Input delay (typ.): For "0" → "1": 50 μs For "1" → "0": 100 μs DI/DO 9, 10, and 11 are "rapid inputs" ²⁾ Input delay (typ.): For "0" → "1": 5 μs For "1" → "0": 50 μs

Max. connectable cross-section: 0.5 mm²
 Type: Spring-loaded terminal 1 (see Appendix A)

1) DI: digital input; DI/DO: bidirectional digital input/output; M: electronics ground; M1: ground reference
 2) The rapid inputs can be used as probe inputs or as inputs for the external zero mark
 3) Data for: V_{cc} = 24 V; load 48 Ω; high ("1") = 90% V_{out}; low ("0") = 10% V_{out}

NOTICE

An open input is interpreted as "low".

To enable the digital inputs (DI) to function, terminal M1 must be connected.

This is achieved by:

1. Providing the ground reference of the digital inputs, or
2. A jumper to terminal M.

Notice! This removes the electrical isolation for these digital inputs.

Note

If the 24 V supply is briefly interrupted, then the digital outputs are deactivated during this time.

2.2.3.5 X132 Digital inputs/outputs

Table 2- 4 Terminal block X132

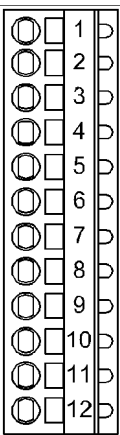
	Terminal	Designation ¹⁾	Technical specifications
	1	DI 4	Voltage: -3 V to +30 VDC Typical current consumption: 10 mA at 24 V Electrical isolation: The reference potential is terminal M2
	2	DI 5	
	3	DI 6	
	4	DI 7	
	5	M2	Level (incl. ripple) High level: 15 V to 30 V Low level: -3 V to +5 V
	6	M	
	7	DI/DO 12	As input: Voltage: -3 V to +30 VDC Typical current consumption: 10 mA at 24 V Level (incl. ripple) High level: 15 V to 30 V Low level: -3 V to +5 V DI/DO 12: Input delay (typ.): For "0" → "1": 50 μs For "1" → "0": 100 μs DI/DO 13, 14, and 15 are "rapid inputs" ²⁾ Input delay (typ.): For "0" → "1": 5 μs For "1" → "0": 50 μs As output: Voltage: 24 V DC Max. load current per output: 500 mA Continued-short-circuit-proof Output delay (typ./max.): ³⁾ For "0" → "1": 150 μs/400 μs For "1" → "0": 75 μs/100 μs Switching frequency: For resistive load: Max. 100 Hz For inductive load: Max. 0.5 Hz For lamp load: Max. 10 Hz Maximum lamp load: 5 W
	8	DI/DO 13	
	9	M	
	10	DI/DO 14	
	11	DI/DO 15	
	12	M	

Max. connectable cross-section: 0.5 mm²
 Type: Spring-loaded terminal 1 (see Appendix A)

1) DI: digital input; DI/DO: bidirectional digital input/output; M: electronics ground; M2: ground reference
 2) The rapid inputs can be used as probe inputs or as inputs for the external zero mark
 3) Data for: V_{cc} = 24 V; load 48 Ω; high ("1") = 90% V_{out}; low ("0") = 10% V_{out}

NOTICE

An open input is interpreted as "low".
 To enable the digital inputs (DI) to function, terminal M2 must be connected.
 This is achieved by:
 1. Providing the ground reference of the digital inputs, or
 2. A jumper to terminal M.
 Notice! This removes the electrical isolation for these digital inputs.

Note

If the 24 V supply is briefly interrupted, then the digital outputs are deactivated during this time.

2.2.3.6 X124 Electronics power supply

Table 2- 5 Terminal block X124

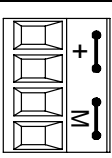
	Terminal	Designation	Technical specifications
	+	Electronics power supply	Voltage: 24 V DC (20.4 V - 28.8 V)
	+	Electronics power supply	
	M	Electronics ground	
	M	Electronics ground	
Max. connectable cross-section: 2.5 mm ² Type: Screw terminal 2 (see Appendix A)			

Note

The two "+" and "M" terminals are jumpered in the connector. This ensures that the supply voltage is looped through.

The current consumption increases by the value for the DRIVE-CLiQ node.

2.2.3.7 X126 PROFIBUS

The PROFIBUS interface is a standard interface on every Control Unit.

Table 2- 6 PROFIBUS interface X126

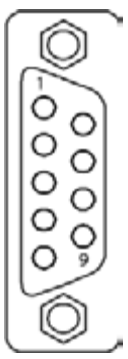
	Pin	Signal name	Meaning	Range
	1	-	Not assigned	
	2	M24_SERV	Teleservice supply, ground	0 V
	3	RxD/TxD-P	Receive/transmit data P (B)	RS485
	4	CNTR-P	Control signal	TTL
	5	DGND	PROFIBUS data reference potential	
	6	VP	Supply voltage plus	5 V ± 10%
	7	P24_SERV	Teleservice supply, + (24 V)	24 V (20.4 V – 28.8 V)
	8	RxD/TxD-N	Receive/transmit data N (A)	RS485
	9	-	Not assigned	

Type: 9-pin SUB-D female

Note

A teleservice adapter can be connected to the PROFIBUS interface (X126) for remote diagnostics purposes.
 The power supply for the teleservice terminals 2 and 7 can have a max. load of 150 mA.

<p>⚠ CAUTION</p> <p>No CAN cables must be connected to interface X126. If CAN cables are connected, the CU320 and other CAN bus nodes may be destroyed.</p>
<p>⚠ CAUTION</p> <p>A potential bonding conductor with a cross-section of at least 25 mm² must be used between components in a system that are located at a distance from each other. If this is not carefully complied with, then significant discharge (leakage) currents can flow through the PROFIBUS cable that will destroy the Control Unit or other devices connecting to PROFIBUS.</p>

PROFIBUS connectors

The first and last nodes in a bus must contain terminating resistors. Otherwise, data transmission will not function correctly.

The bus terminating resistors are activated in the connector.

The cable shield must be connected at both ends and over a large surface area.

2.2.3.8 PROFIBUS address switches

Table 2- 7 PROFIBUS address switches

Technical specifications	Switch	Significance
<p>Significance: 2^0 2^1 2^2 2^3 2^4 2^5 2^6 1 2 4 8 16 32 64</p>  <p>S1 S2 S3 S4 S5 S6 S7</p> <p>Example: 1 + 4 + 32 = 37 PROFIBUS address = 37</p>	S1	$2^0 = 1$
	S2	$2^1 = 2$
	S3	$2^2 = 4$
	S4	$2^3 = 8$
	S5	$2^4 = 16$
	S6	$2^5 = 32$
	S7	$2^6 = 64$

Note

The factory setting of the DIP switch is 0 or 127. Parameter p0918 can be used to set the bus address for PROFIBUS to values between 1 and 126. The address can also be set manually to values between 1 and 126 using the DIP switch. Then, it is only possible to read the address with p0918.

The address switch is behind the blanking plate. The blanking plate is part of the scope of supply.

Setting the PROFIBUS address

The following reference contains further information about setting the PROFIBUS address:

Reference: /IH1/ SINAMICS S120 Commissioning Manual

2.2.3.9 Serial interface (RS232) X140

An external display and operator device for operator control/parameterization can be connected via the serial interface. The interface is located on the underside of the CU.

Table 2- 8 Serial interface (RS-232-C) X140

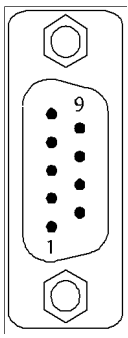
	Pin	Name	Technical Specifications
	2	RxD	Receive data
	3	TxD	Transmit data
	5	Ground	Ground reference

2.2.3.10 Measuring sockets

Table 2- 9 Measuring sockets T0, T1, and T2

Socket	Function	Technical specifications
T0	Measuring socket 0	Voltage: 0 V to 5 V Resolution: 8 bits Load current: max. 3 mA Continued-short-circuit-proof
T1	Measuring socket 1	
T2	Measuring socket 2	
M	Ground	The reference potential is terminal M

The measuring sockets are only suitable for bunch pin plugs with a diameter of 2 mm.

Note

The test sockets are provided as a support to commissioning and diagnostics; they must not be connected for normal operation.

2.2.3.11 Slot for the CompactFlash card

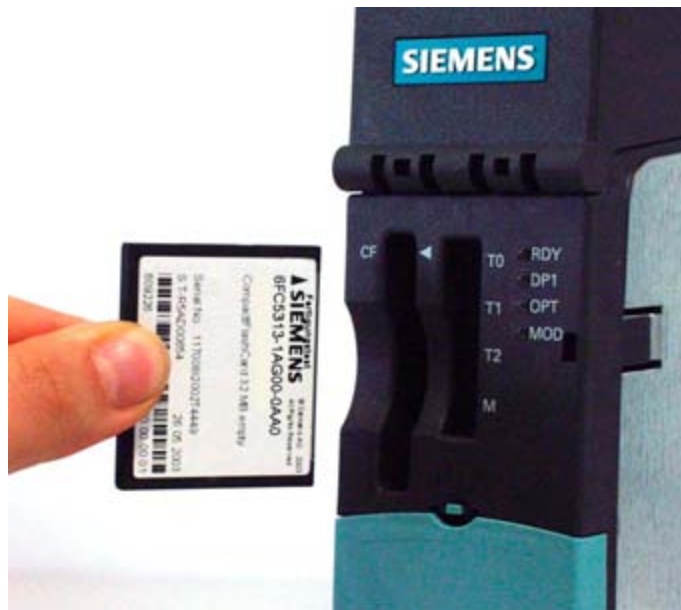

Figure 2-6 Slot for CompactFlash card

CAUTION

The CompactFlash card may only be removed and inserted when the Control Unit is in a voltage-free state; doing this during operation instead could result in a loss of data and, where applicable, a plant standstill.

The CompactFlash card may only be inserted as shown in the photo above (arrow at top right).

CAUTION

The CompactFlash card is an electrostatic sensitive component. ESD regulations must be observed when inserting and removing the card.

NOTICE

When returning a defective Control Unit, remove the CompactFlash card and keep it for insertion in the replacement unit. This is important otherwise the data on the CompactFlash card (parameters, firmware, licenses, and so on) may be lost.

Note

Please note that only SIEMENS CompactFlash cards can be used to operate the Control Unit.

2.2.3.12 Description of the LEDs on the Control Unit CU320

Description of the LED statuses

The different statuses that arise during the booting procedure are indicated by means of the LEDs on the Control Unit.

- The duration of the individual statuses varies.
- If an error occurs, the booting procedure is terminated and the cause is indicated accordingly via the LEDs.
- Once the unit has successfully booted up, all the LEDs are switched off briefly.
- Once the unit has booted up, the LEDs are controlled via the loaded software.

Behavior of the LEDs during booting

Table 2- 10 Load software 1

LED				Status	Comment
RDY	DP1	OPT	MOD		
red	red	red	off	Reset	Hardware reset
red 2 Hz	red	red	off	error	<ul style="list-style-type: none"> • Memory card not inserted or • Load software 2 has not been installed on the memory card or is defective.

Table 2- 11 Load software 2

LED				Status	Comment
RDY	DP1	OPT	MOD		
off	red	red	off	Loaded	–
off	orange	red	off	running	–
off	red 2 Hz	red	off	error file	Software on the memory card is incomplete or defective.
off	red 0.5 Hz	red	off	error crc	CRC invalid.
off	off	red	off	FW loaded	–

Table 2- 12 Firmware

LED				Status	Comment
RDY	DP1	OPT	MOD		
off	off	off	off	initializing	–
alternating				running	See the table below

Behavior of the LEDs after booting

Table 2- 13 Control Unit - Description of the LEDs after booting

LED	Color	Status	Description, cause	Remedy
RDY (READY)	-	OFF	Electronics power supply is missing or outside permissible tolerance range.	-
	Green	Continuous light	The component is ready and cyclic DRIVE-CLiQ communication takes place or the Control Unit waits for initial commissioning.	-
		2 Hz flashing light	Writing to the memory card.	-
	Red	Continuous light	At least one fault is present in this component.	Remedy and acknowledge fault
		2 Hz flashing light	Boot error	Make sure that the memory card has been inserted properly Replace the memory card Replace Control Unit Carry out a POWER ON
	Green/red	0.5 Hz flashing light	Control Unit 320 is ready for operation. However there are no software licenses.	Obtain licenses
	Orange	Continuous light	System booting and DRIVE-CLiQ communication is being established.	-
		0.5 Hz flashing light	Updating the firmware of the DRIVE-CLiQ components	-
		2 Hz flashing light	Firmware update is complete for components. Wait for POWER ON for the components in question.	Turn POWER ON for the components in question
	Green/orange or red/orange	1 Hz flashing light	Component detection via LED is activated (p0124[0]). Note: Both options depend on the LED status when component recognition is activated via p0124[0] = 1.	-
DP1 PROFIdrive cyclic operation	-	Off	Cyclic communication has not (yet) taken place. Note: The PROFIdrive is ready to communicate when the Control Unit is ready to operate (see LED RDY).	-
	Green	Continuous light	Cyclic communication is taking place.	-

LED	Color	Status	Description, cause	Remedy
		0.5 Hz flashing light	Full cyclic communication has not yet taken place. Possible causes: <ul style="list-style-type: none"> • The controller is not transferring any setpoints. • During isochronous operation, no global control (GC) or a faulty global control (GC) is transferred by the controller. 	–
	Red	Continuous light	Cyclic communication has been interrupted.	Remedy fault
	Orange	2 Hz flashing light	Firmware CRC error.	Make sure that the memory card has been inserted properly Replace the memory card Replace Control Unit Carry out a POWER ON
OPT (OPTION)	–	Off	Electronics power supply missing, is outside permissible tolerance range, component is not ready for operation, Option Board is not available, no associated drive object has been created,	–
	Green	Continuous light	Option board is ready.	–
		0.5 Hz flashing light	Depends on the option board used.	–
	Red	Continuous light	At least one fault is present in this component. Option board not ready (e.g. after power-on).	Remedy and acknowledge fault
MOD	–	Off	Reserved	–

2.2.4 Dimension drawing

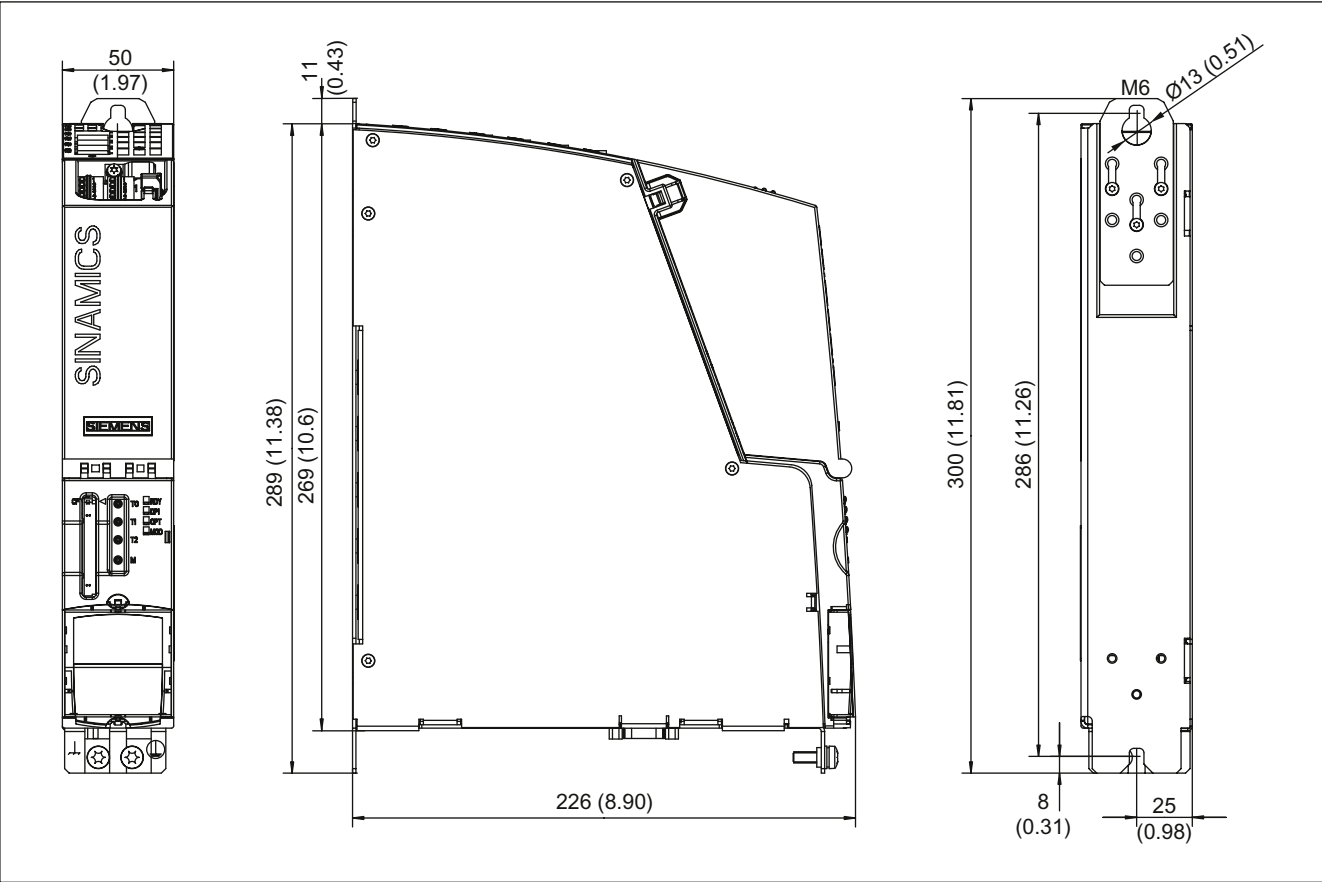
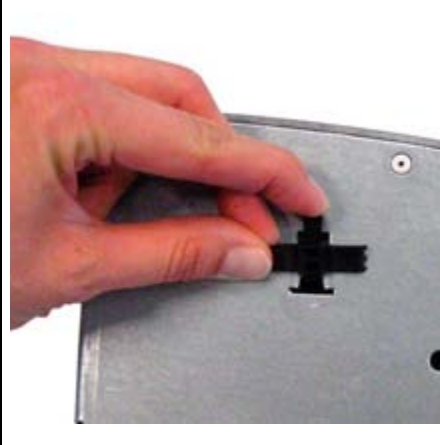
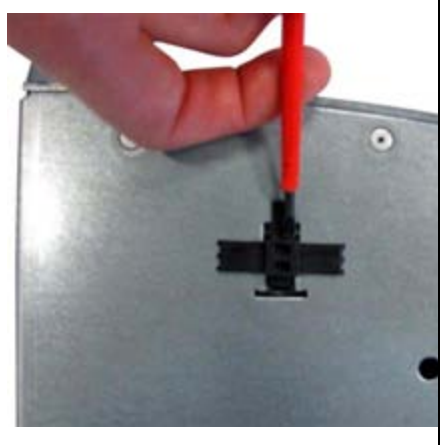



Figure 2-7 Dimension drawing of CU320, all data in mm and (inches)

2.2.5 Installation

Installing the holders for securing the Control Unit

		
<p>Insert the holder into the installation opening provided.</p>	<p>Use a suitable tool (such as a screwdriver) to push the holder in as far as it will go.</p>	<p>Installed holders (3 pieces) from the Line Module accessories kit</p>

Installing the CU320 directly on a Line Module in booksize format or a power unit in chassis format

The Control Unit CU320-2 DP features integrated lateral holders, which enable it to be installed directly on a Line Module in booksize format or a power unit in chassis format. The holders required to do this are supplied together with the Line Modules and the power units in the chassis format.

Table 2- 14 Installing the CU320 on a Line Module in the booksize format

<p>Attach the Control Unit to the Line Module using the three holders</p>	<p>Push the Control Unit downwards until it latches into place</p>	<p>Control Unit installed - the front is flush to the Line Module</p>

Installing the CU320 directly on a mounting surface

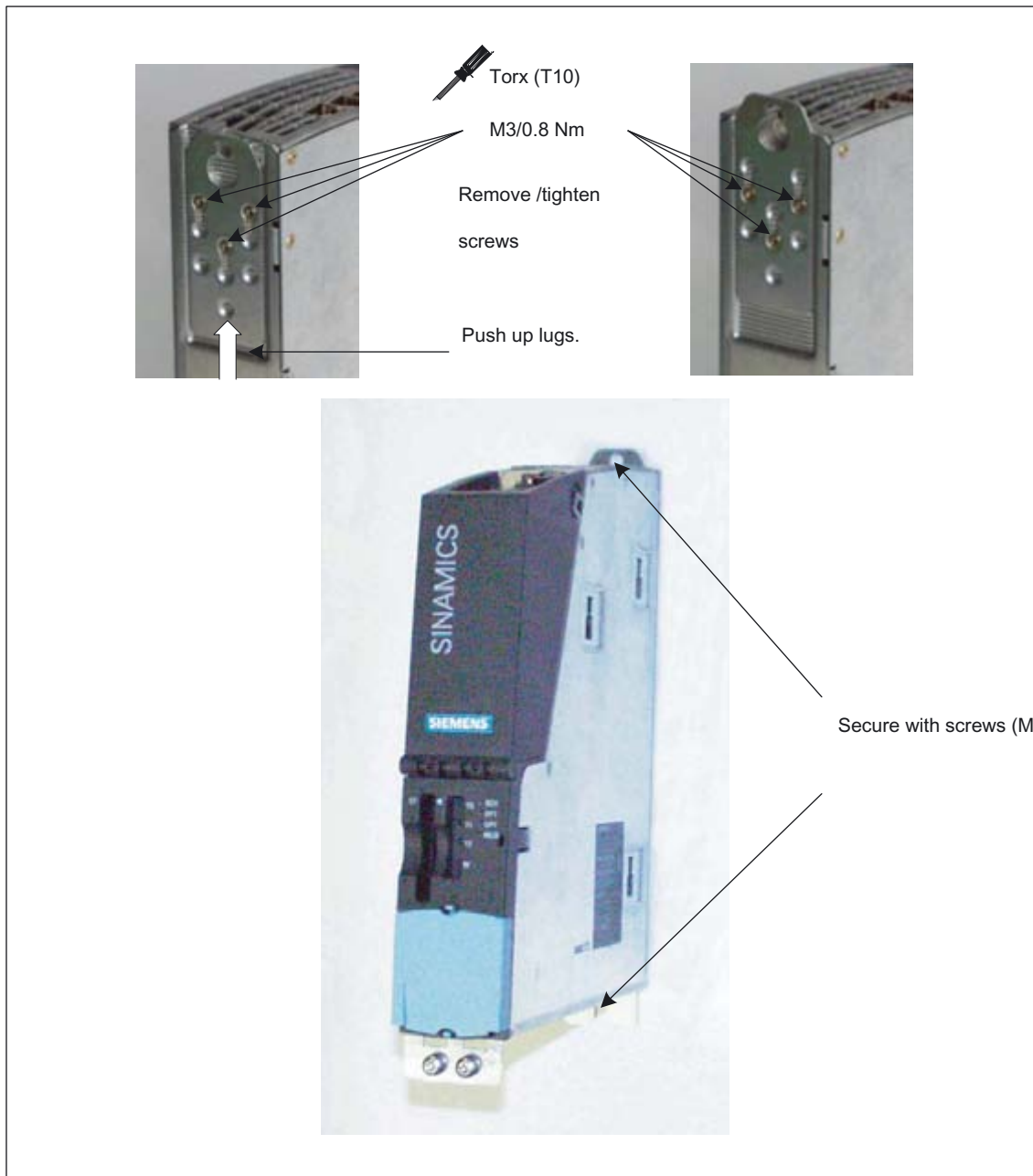

Figure 2-8 Installing the CU320 directly on a mounting surface

Installing the CU320 on a mounting surface using spacer elements

To provide the correct mounting depth for a booksize line-up with internal air cooling, you can use spacer elements (2 elements: 6SL3064-1BB00-0AA0) can be installed.

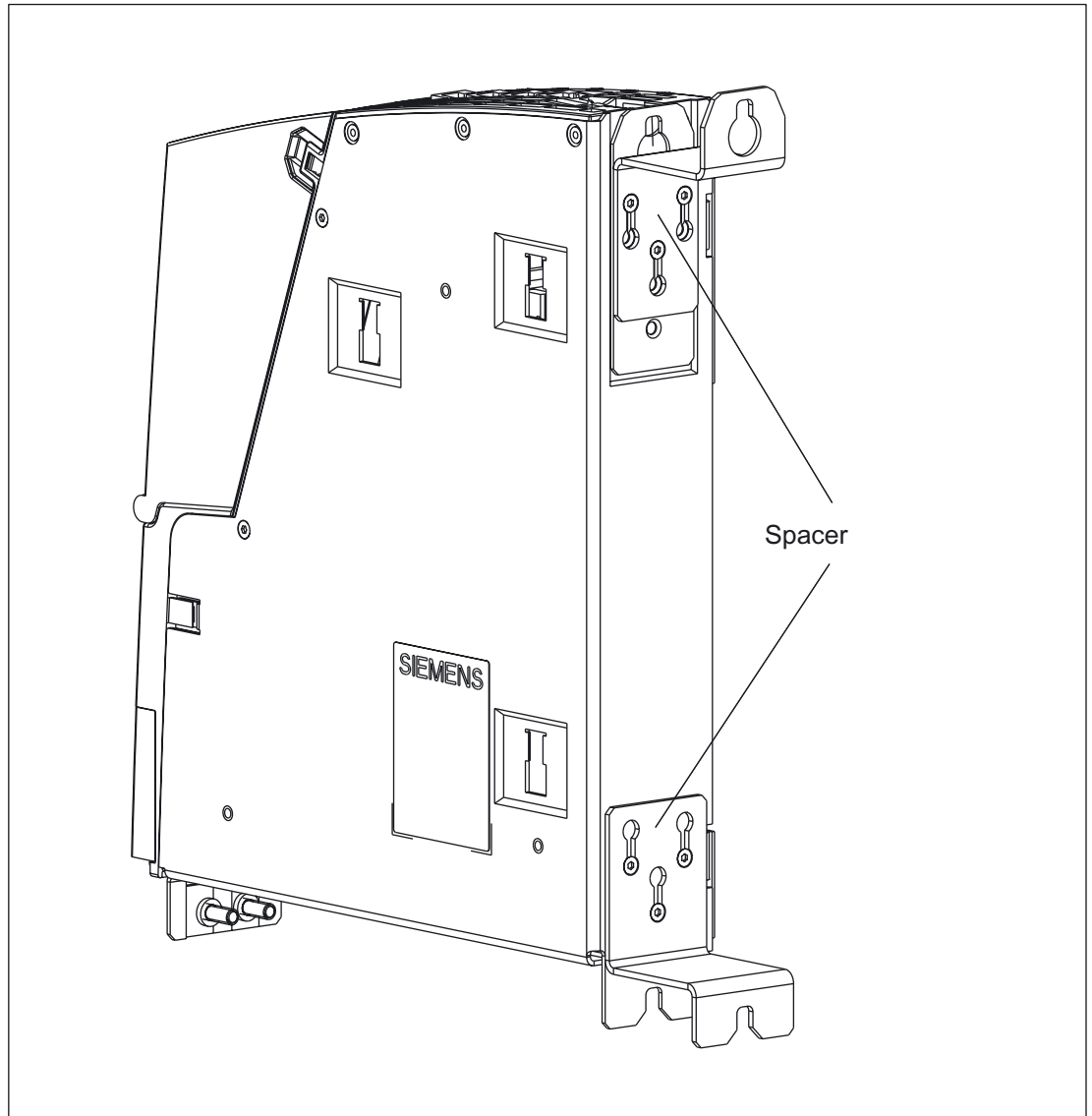

Figure 2-9 Installing the CU320 on a mounting surface using spacer elements

Removing/opening the cover of the CU320

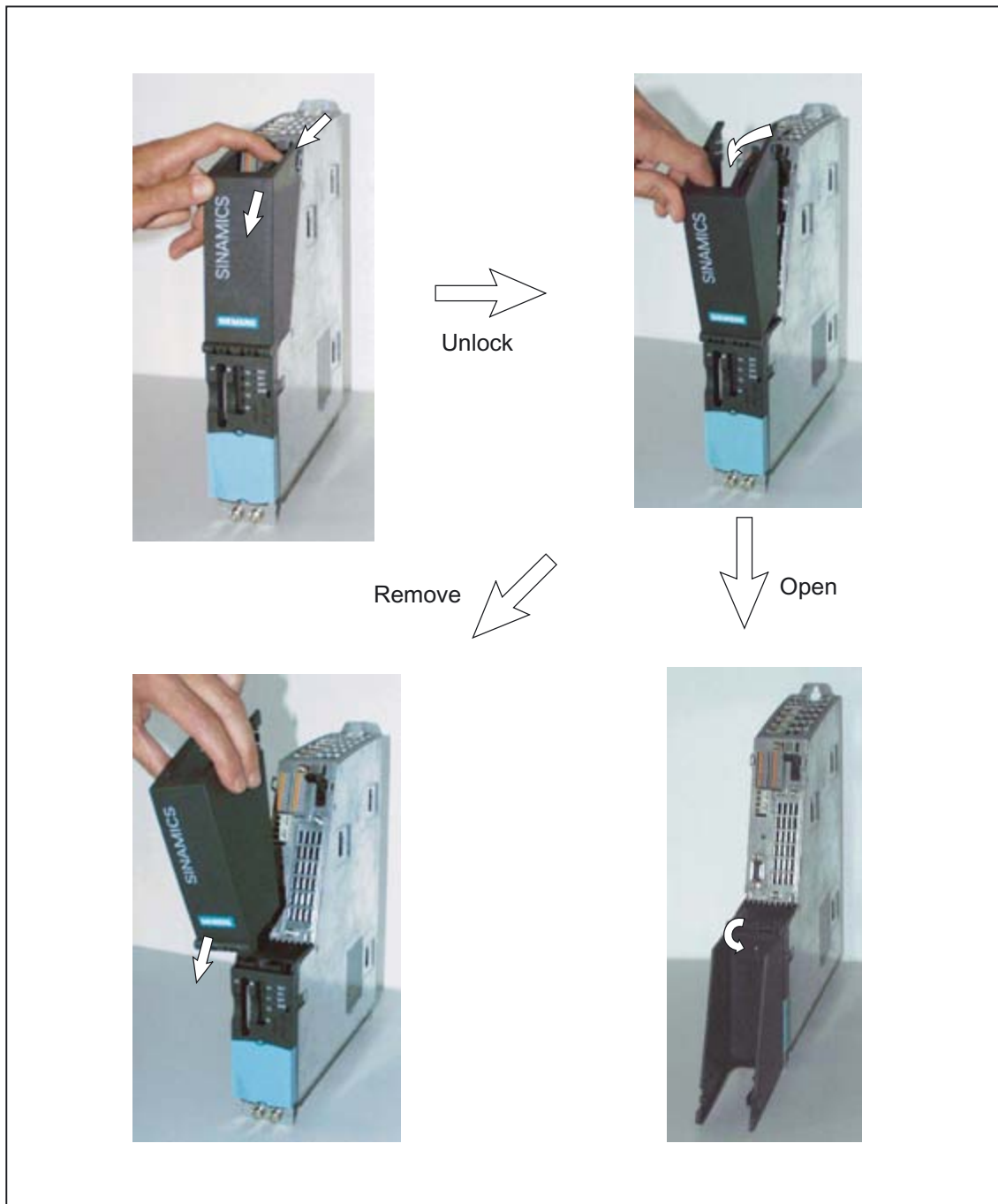

Figure 2-10 Removing/opening the cover of the CU320

2.2.6 Technical data

Table 2- 15 Technical data

6SL3040-0MA00-0AAx	Unit	Value
Electronics power supply		
Voltage	V _{DC}	24 DC (20.4 – 28.8)
Current (without DRIVE-CLiQ or digital outputs)	A _{DC}	0.8
Power loss	W	20
Maximum DRIVE-CLiQ cable length	m	100
PE/ground connection	On housing with M5/3 Nm screw	
Response time	The response time of digital inputs/outputs depends on the evaluation (refer to the function diagram). References: / LH1/ SINAMICS S List Manual, Chapter "Function diagrams".	
Weight	kg	1.5

2.3 Control Unit CU320-2 DP

2.3.1 Description

The Control Unit CU320-2 DP is a central control module in which the closed-loop and open-loop functions are implemented for one or more Line Modules and/or Motor Modules. It can be used with firmware version 4.3 or higher.

The CU320-2 DP has the following interfaces (ports):

Table 2- 16 Overview of the CU320-2 DP interfaces

Type	Quantity
Digital inputs	12
Digital inputs/outputs	8
DRIVE-CLiQ interfaces	4
PROFIBUS interface	1
LAN (Ethernet)	1
Serial interface (RS232)	1
Option slot	1
Measuring sockets	3

2.3.2 Safety information

⚠ WARNING

The ventilation spaces of 80 mm above and below the component must be observed.

⚠ CAUTION

A potential bonding conductor with a cross-section of at least 25 mm² must be used between components in a system that are located at a distance from each other. If a potential bonding conductor is not used, high leakage currents that could destroy the Control Unit or other PROFIBUS nodes can be conducted via the PROFIBUS cable.

CAUTION

The CompactFlash card may only be removed and inserted when the Control Unit is in a voltage-free state; doing this during operation instead could result in a loss of data and, where applicable, a plant standstill.

CAUTION

The CompactFlash card is an electrostatic sensitive component. ESD regulations must be observed when inserting and removing the card.

CAUTION

The Option Board should only be inserted and removed when the Control Unit and Option Board are at zero current.

2.3.3 Interface description

2.3.3.1 Overview

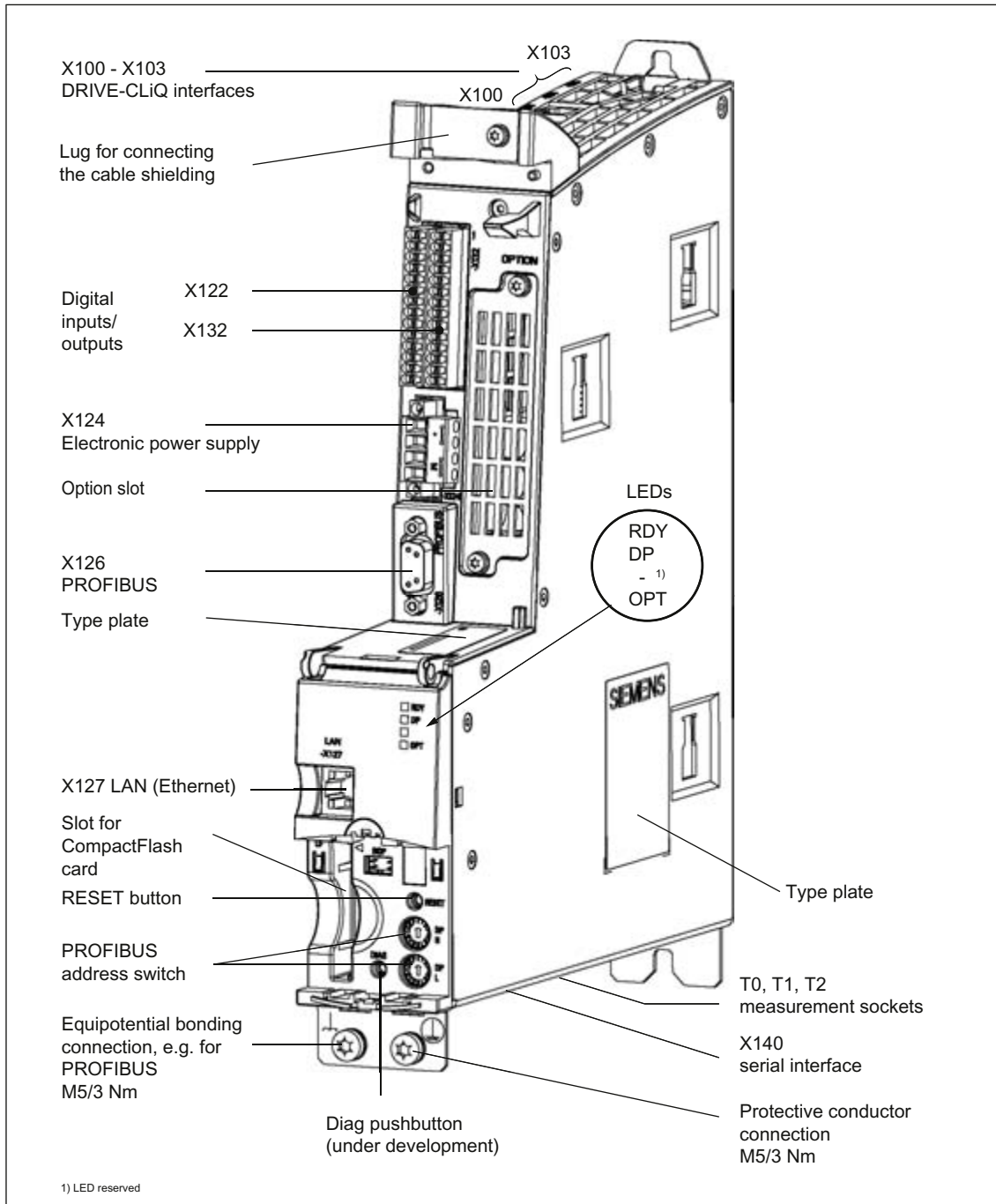

Figure 2-11 Interface description of the CU320-2 DP (covers removed)

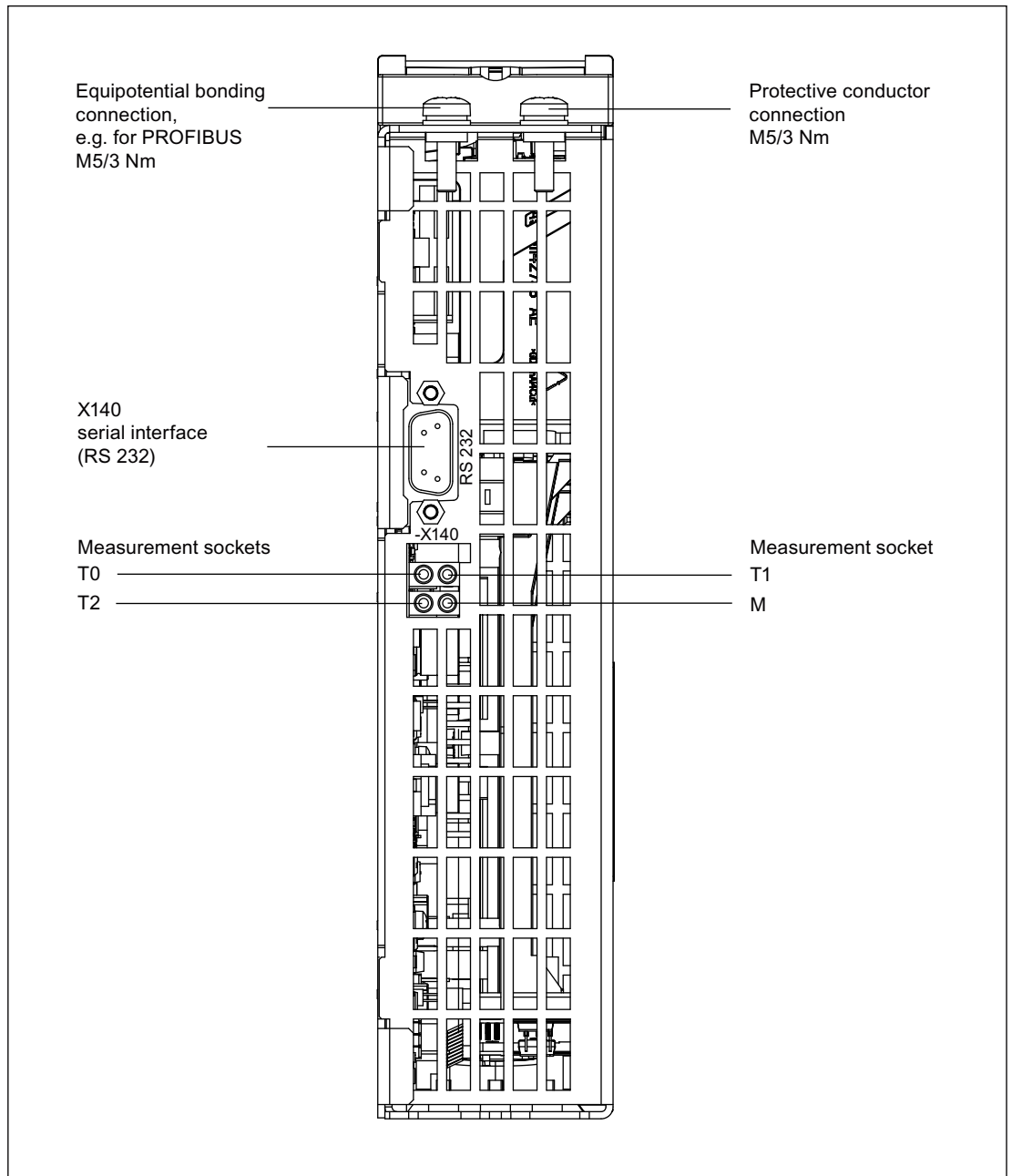

Figure 2-12 Interface X140 and measuring sockets T0 to T2 - CU320-2 DP (view from below)

2.3.3.2 Connection example

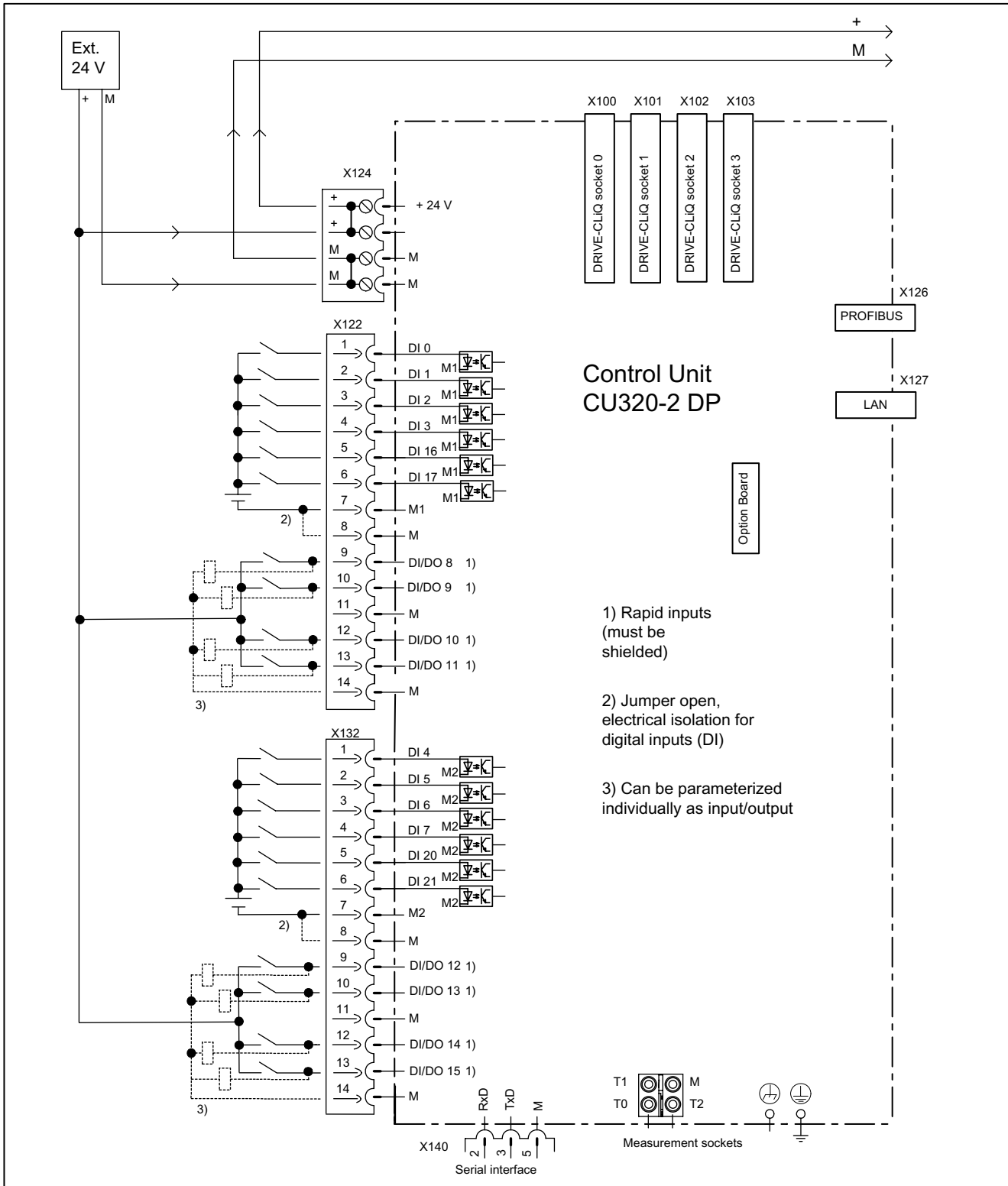
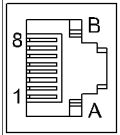

Figure 2-13 Connection example of CU320-2 DP

2.3.3.3 X100 - X103 DRIVE-CLiQ interface

Table 2- 17 DRIVE-CLiQ interface

	Pin	Signal name	Technical specifications	
	1	TXP	Transmit data +	
	2	TXN	Transmit data -	
	3	RXP	Receive data +	
	4	Reserved, do not use		
	5	Reserved, do not use		
	6	RXN	Receive data -	
	7	Reserved, do not use		
	8	Reserved, do not use		
	A	+ (24 V)	Power supply	
	B	M (0 V)	Electronics ground	
	Connector type: RJ45 socket; blanking plate for DRIVE-CLiQ interface included in the scope of delivery; blanking plate (50 pieces) order number: 6SL3066-4CA00-0AA0			

2.3.3.4 X122 Digital inputs/outputs

Table 2- 18 Terminal block X122

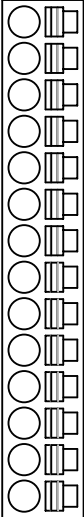
	Terminal	Designation ¹⁾	Technical specifications
	1	DI 0	Voltage: -30 V to +30 VDC Typical current consumption: 9 mA at 24 V Electrical isolation: The reference potential is terminal M1 Level (incl. ripple) High level: 15 V to 30 V Low level: -30 V to +5 V Input delay (typ.): For "0" → "1": 50 µs For "1" → "0": 150 µs
	2	DI 1	
	3	DI 2	
	4	DI 3	
	5	DI 16	
	6	DI 17	
	7	M1	Reference potential for terminals 1 to 6
	8	M	Ground
	9	DI/DO 8	As input: Voltage: -30 V to +30 VDC Typical current consumption: 9 mA at 24 V Level (incl. ripple) High level: 15 V to 30 V Low level: -30 V to +5 V DI/DO 8, 9, 10, and 11 are "rapid inputs" ²⁾ Input delay (typ.): For "0" → "1": 5 µs For "1" → "0": 50 µs As output: Voltage: 24 V DC Max. load current per output: 500 mA Continued-short-circuit-proof Output delay (typ./max.): ³⁾ For "0" → "1": 150 µs/400 µs For "1" → "0": 75 µs/100 µs Switching frequency: For resistive load: Max. 100 Hz For inductive load: Max. 0.5 Hz For lamp load: Max. 10 Hz Maximum lamp load: 5 W
	10	DI/DO 9	
	11	M	
	12	DI/DO 10	
	13	DI/DO 11	
	14	M	

Max. connectable cross-section: 1.5 mm²
 Type: Spring-loaded terminal 3 (see Appendix A)

1) DI: digital input; DI/DO: bidirectional digital input/output; M: electronics ground; M1: ground reference

2) The rapid inputs can be used as probe inputs or as inputs for the external zero mark

3) Data for: V_{cc} = 24 V; load 48 Ω; high ("1") = 90% V_{out}; low ("0") = 10% V_{out}

NOTICE

An open input is interpreted as "low".

To enable the digital inputs (DI) to function, terminal M1 must be connected.

This is achieved by:

1. Providing the ground reference of the digital inputs, or
2. A jumper to terminal M.

Notice! This removes the electrical isolation for these digital inputs.

Note

If the 24 V supply is briefly interrupted, then the digital outputs are deactivated during this time.

2.3.3.5 X132 Digital inputs/outputs

Table 2- 19 Terminal block X132

	Terminal	Designation ¹⁾	Technical specifications
	1	DI 4	Voltage: -30 V to +30 VDC Typical current consumption: 9 mA at 24 V Electrical isolation: The reference potential is terminal M2 Level (incl. ripple) High level: 15 to 30 V Low level: -30 V to +5 V Input delay (typ.): For "0" → "1": 50 μs For "1" → "0": 150 μs
	2	DI 5	
	3	DI 6	
	4	DI 7	
	5	DI 20	
	6	DI 21	
	7	M2	Reference potential for terminals 1 to 6
	8	M	Ground
	9	DI/DO 12	As input: Voltage: -30 V to +30 VDC Typical current consumption: 9 mA at 24 V Level (incl. ripple) High level: 15 to 30 V Low level: -30 V to +5 V DI/DO 12, 13, 14, and 15 are "rapid inputs" ²⁾ Input delay (typ.): For "0" → "1": 5 μs For "1" → "0": 50 μs As output: Voltage: 24 V DC Max. load current per output: 500 mA Continued-short-circuit-proof Output delay (typ./max.): ³⁾ For "0" → "1": 150 μs/400 μs For "1" → "0": 75 μs/100 μs Switching frequency: For resistive load: Max. 100 Hz For inductive load: Max. 0.5 Hz For lamp load: Max. 10 Hz Maximum lamp load: 5 W
	10	DI/DO 13	
	11	M	
	12	DI/DO 14	
	13	DI/DO 15	
	14	M	
Max. connectable cross-section: 1.5 mm ² Type: Spring-loaded terminal 3 (see Appendix A)			

1) DI: digital input; DI/DO: digital input/output; M: electronics ground; M2: ground reference

2) The rapid inputs can be used as probe inputs or as inputs for the external zero mark

3) Data for: V_{cc} = 24 V; load 48 Ω; high ("1") = 90% V_{out}; low ("0") = 10% V_{out}

<p>NOTICE</p> <p>An open input is interpreted as "low".</p> <p>To enable the digital inputs (DI) to function, terminal M2 must be connected.</p> <p>This is achieved by:</p> <ol style="list-style-type: none"> 1. Providing the ground reference of the digital inputs, or 2. A jumper to terminal M. <p>Notice! This removes the electrical isolation for these digital inputs.</p>

Note

If the 24 V supply is briefly interrupted, then the digital outputs are deactivated during this time.

2.3.3.6 X124 Electronics power supply

Table 2- 20 Terminal block X124

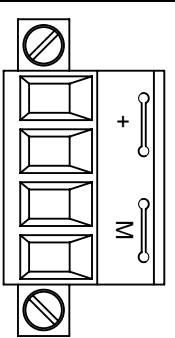
	Terminal	Designation	Technical specifications
	+	Electronics power supply	Voltage: 24 V DC (20.4 V to 28.8 V) Current consumption: Max. 1.0 A (without DRIVE-CLiQ or digital outputs) Max. current via jumper in connector: 20 A
	+	Electronics power supply	
	M	Electronics ground	
	M	Electronics ground	
Max. connectable cross-section: 2.5 mm ² Type: Screw terminal 2 (see Appendix A)			

Note

The two "+" and "M" terminals are jumpered in the connector. This ensures that the supply voltage is looped through.

The current consumption increases by the value for the DRIVE-CLiQ node and digital outputs.

Note

The terminal block must be screwed on tightly using a flat-bladed screwdriver.

2.3.3.7 X126 PROFIBUS

Table 2- 21 PROFIBUS interface X126

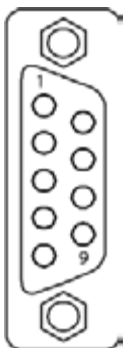
	Pin	Signal name	Meaning	Range
	1	-	Not assigned	
	2	M24_SERV	Teleservice supply, ground	0 V
	3	RxD/TxD-P	Receive/transmit data P (B)	RS485
	4	CNTR-P	Control signal	TTL
	5	DGND	PROFIBUS data reference potential	
	6	VP	Supply voltage plus	5 V ± 10%
	7	P24_SERV	Teleservice supply, + (24 V)	24 V (20.4 V to 28.8 V)
	8	RxD/TxD-N	Receive/transmit data N (A)	RS485
	9	-	Not assigned	

Connector type: 9-pin SUB-D female

Note

A teleservice adapter can be connected to the PROFIBUS interface (X126) for remote diagnostics purposes.
 The power supply for the teleservice terminals 2 and 7 can have a max. load of 150 mA.

CAUTION
 No CAN cables must be connected to interface X126. If CAN cables are connected, the Control Unit and other CAN bus nodes may be destroyed.

CAUTION
 A potential bonding conductor with a cross-section of at least 25 mm² must be used between components in a system that are located at a distance from each other. If a potential bonding conductor is not used, high leakage currents that could destroy the Control Unit or other PROFIBUS nodes can be conducted via the PROFIBUS cable.

PROFIBUS connectors

The first and last nodes in a bus must contain terminating resistors. Otherwise, data transmission will not function correctly.

The bus terminating resistors are activated in the connector.

The cable shield must be connected at both ends and over a large surface area.

2.3.3.8 PROFIBUS address switch

On the CU320-2, the PROFIBUS address is set as a hexadecimal value via two rotary coding switches. Values between 0_{dec} (00_{hex}) and 127_{dec} (7F_{hex}) can be set as the address. The upper rotary coding switch (H) is used to set the hexadecimal value for 16¹ and the lower rotary coding switch (L) is used to set the hexadecimal value for 16⁰.

Table 2- 22 PROFIBUS address switch

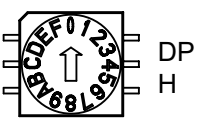
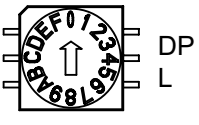
Rotary coding switches	Significance	Examples		
		21 _{dec}	35 _{dec}	126 _{dec}
		15 _{hex}	23 _{hex}	7E _{hex}
	16 ¹ = 16	1	2	7
	16 ⁰ = 1	5	3	E

Setting the PROFIBUS address

The factory setting for the rotary coding switches is 0_{dec} (00_{hex}).

There are two ways to set the PROFIBUS address:

1. Via p0918
 - To set the bus address for a PROFIBUS node using STARTER, first set the rotary code switches to 0_{dec} (00_{hex}) and 127_{dec} (7F_{hex}).
 - Then use parameter p0918 to set the address to a value between 1 and 126.
2. Via the PROFIBUS address switches on the Control Unit
 - The address is set manually to values between 1 and 126 using the rotary coding switches. In this case, p0918 is only used to read the address.

The address switch is behind the blanking plate. The blanking plate is part of the scope of supply.

Setting the PROFIBUS address

The following reference source contains further information about setting the PROFIBUS address:

References: /IH1/ SINAMICS S120 Commissioning Manual

2.3.3.9 X127 LAN (Ethernet)

Table 2- 23 X127 LAN (Ethernet)

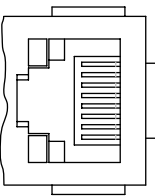
	Pin	Designation	Technical specifications
	1	TXP	Ethernet transmit data +
	2	TXN	Ethernet transmit data -
	3	RXP	Ethernet receive data +
	4	Reserved, do not use	
	5	Reserved, do not use	
	6	RXN	Ethernet receive data -
	7	Reserved, do not use	
	8	Reserved, do not use	

Connector type: RJ45 socket

Note

The X127 interface supports commissioning and diagnostic functions for firmware version 4.3 or higher. It must not be connected for normal operation.

For diagnostic purposes, the X127 LAN interface features a green and a yellow LED. These LEDs indicate the following status information:

Table 2- 24 LED statuses for the X127 LAN interface

LED	Status	Description
Green	On	10 or 100 Mbit link available
	Off	Missing or faulty link
Yellow	On	Sending or receiving
	Off	No activity

2.3.3.10 X140 serial interface (RS232)

An external display and operator device for operator control/parameterization can be connected via the serial interface. The interface is located on the lower side of the Control Unit.

Table 2- 25 Serial interface (RS-232-C) X140

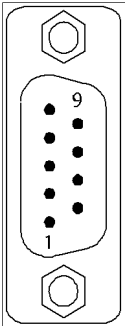
	Pin	Designation	Technical data
	1	Reserved, do not use	
	2	RxD	Receive data
	3	TxD	Transmit data
	4	Reserved, do not use	
	5	Ground	Ground reference
	6	Reserved, do not use	
	7	Reserved, do not use	
	8	Reserved, do not use	
	9	Reserved, do not use	

Connector type: SUB-D, 9-pin

2.3.3.11 Measuring sockets

Table 2- 26 Measuring sockets T0, T1, T2

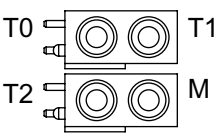
	Socket	Function	Technical specifications
	T0	Measuring socket 0	Voltage: 0 V to 5 V Resolution: 8 bits Load current: max. 3 mA Continued-short-circuit-proof The reference potential is terminal M
	T1	Measuring socket 1	
	T2	Measuring socket 2	
	M	Ground	

The measuring sockets are only suitable for bunch pin plugs with a diameter of 2 mm.

Note

The measuring sockets support commissioning and diagnostic functions. It must not be connected for normal operation.

2.3.3.12 Slot for the CompactFlash card



Figure 2-14 Slot for CompactFlash card

CAUTION

The CompactFlash card may only be removed and inserted when the Control Unit is in a voltage-free state; doing this during operation instead could result in a loss of data and, where applicable, a plant standstill.

The CompactFlash card may only be inserted as shown in the photo above (arrow at top right).

CAUTION

The CompactFlash card is an electrostatic sensitive component. ESD regulations must be observed when inserting and removing the card.

NOTICE

When returning a defective Control Unit, remove the CompactFlash card and keep it for insertion in the replacement unit. This is important otherwise the data on the CompactFlash card (parameters, firmware, licenses, and so on) may be lost.

Note

Please note that only SIEMENS CompactFlash cards can be used to operate the Control Unit.

2.3.3.13 Description of the LEDs on the Control Unit CU320-2 DP

Description of the LED statuses

The different statuses that arise during the booting procedure are indicated by means of the LEDs on the Control Unit.

- The duration of the individual statuses varies.
- If an error occurs, the booting procedure is terminated and the cause is indicated accordingly via the LEDs.
- Once the unit has successfully booted up, all the LEDs are switched off briefly.
- Once the unit has booted up, the LEDs are controlled via the loaded software.

Behavior of the LEDs during booting

Table 2- 27 Load software

LED			Status	Comment
RDY	DP	OPT		
red	orange	orange	Reset	Hardware reset RDY LED lights up red, all other LEDs light up orange
red	red	off	BIOS loaded	–
red 2 Hz	red	off	BIOS error	• Error occurred while loading the BIOS
red 2 Hz	red 2 Hz	off	File error	• CompactFlash card not inserted or defective • Software has not been installed on the CompactFlash card or is defective
red	off	off	FW loaded	–
off	red	off	FW checked (no CRC error)	
red 0.5 Hz	red 0.5 Hz	off	FW checked (CRC error)	• CRC invalid
orange	off	off	Start DRIVE-CLiQ communication	

Table 2- 28 Firmware

LED			Status	Comment
RDY	DP	OPT		
off	off	off	Initializing	–
alternating			Running	See the table below

Behavior of the LEDs after booting

Table 2- 29 Control Unit CU320-2 DP – Description of the LEDs after booting

LED	Color	Status	Description, cause	Remedy
RDY (READY)	-	OFF	Electronics power supply is missing or outside permissible tolerance range.	Check power supply
	Green	Continuous light	The component is ready for operation and cyclic DRIVE-CLiQ communication is taking place.	-
		0.5 Hz flashing light	Commissioning/reset	-
		2 Hz flashing light	Writing to CompactFlash card	-
	Red	2 Hz flashing light	General errors	Check parameterization/configuration data
	Red/green	0.5 Hz flashing light	Control Unit is ready for operation. However there are no software licenses.	Obtain licenses
	Orange	0.5 Hz flashing light	Updating the firmware of the DRIVE-CLiQ components	-
		2 Hz flashing light	DRIVE-CLiQ component firmware update complete. Wait for POWER ON for the components in question.	Turn POWER ON for the components in question
	Green/orange or red/orange	1 Hz flashing light	Component detection via LED is activated (p0124[0]). Note: Both options depend on the LED status when component detection is activated via p0124[0] = 1.	-
DP PROFIdrive cyclic operation	-	Off	Cyclic communication has not (yet) taken place. Note: The PROFIdrive is ready to communicate when the Control Unit is ready to operate (see LED RDY).	-
	Green	Continuous light	Cyclic communication is taking place.	-
		0.5 Hz flashing light	Full cyclic communication has not yet taken place. Possible causes: <ul style="list-style-type: none"> The controller is not transferring any setpoints. During isochronous operation, no global control (GC) or a faulty global control (GC) is transferred by the controller. 	-
	Red	0.5 Hz flashing light	PROFIBUS master is sending wrong parameterization/configuration data	Adapt configuration between master/controller and CU

LED	Color	Status	Description, cause	Remedy
		2 Hz flashing light	Cyclic bus communication has been interrupted or could not be established	Remedy fault
OPT (OPTION)	–	Off	Electronics power supply is missing or outside permissible tolerance range. Component is not ready. Option board not installed or no associated drive object has been created.	Check power supply and/or component
	Green	Continuous light	Option board is ready.	–
		0.5 Hz flashing light	Depends on the option board used.	–
	Red	Continuous light	At least one fault is present in this component. Option board not ready (e.g. after power-on).	Remedy and acknowledge fault
RDY and DP	Red	2 Hz flashing light	Bus error - communication has been interrupted	Remedy fault

2.3.4 Dimension drawing

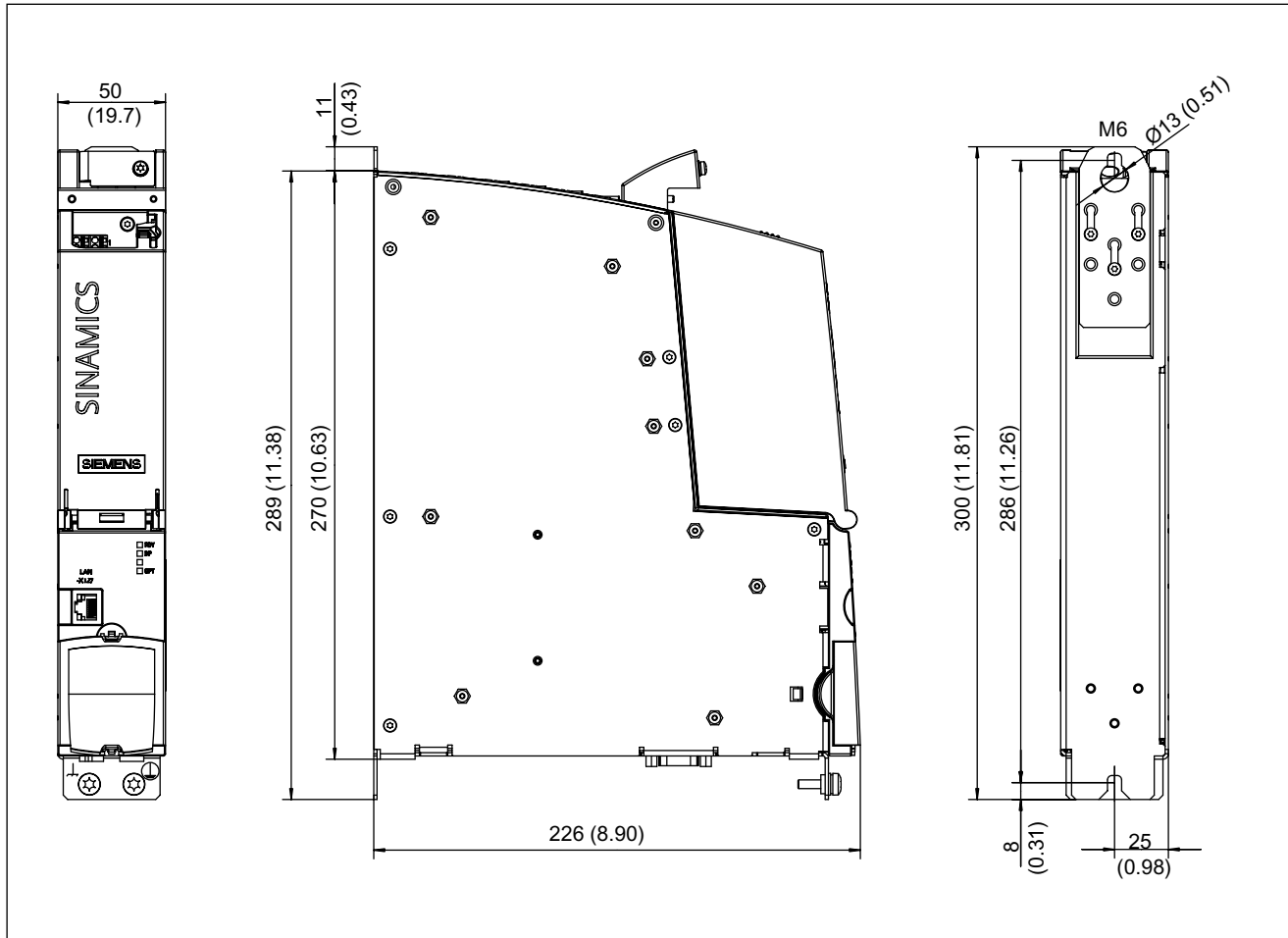
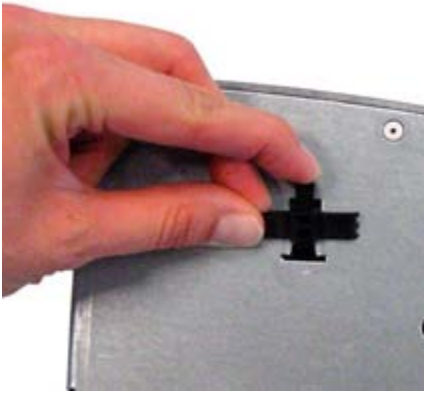
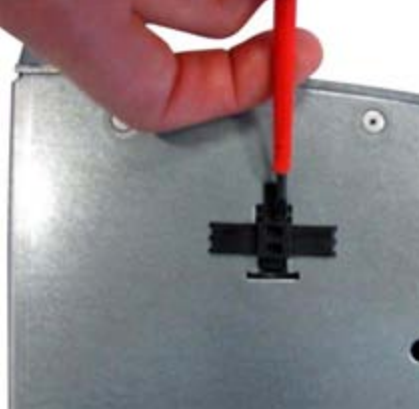



Figure 2-15 Dimension drawing of CU320-2 DP, all data in mm and (inches)

2.3.5 Installation

Installing the holders for securing the Control Unit

		
<p>Insert the holder into the installation opening provided.</p>	<p>Use a suitable tool (such as a screwdriver) to push the holder in as far as it will go.</p>	<p>Installed holders (3 pieces) from the Line Module accessories kit</p>

Installing the CU320-2 DP directly on a Line Module in booksize format or a power unit in chassis format

The Control Unit CU320-2 DP features integrated lateral holders, which enable it to be installed directly on a Line Module in booksize format or a power unit in chassis format. The holders required to do this are supplied together with the Line Modules and the power units in the chassis format.

Table 2- 30 Installing the CU320-2 DP on a Line Module in the booksize format

<p>Attach the Control Unit to the Line Module using the three holders</p>	<p>Push the Control Unit downwards until it latches into place</p>	<p>Control Unit installed - the front is flush to the Line Module</p>

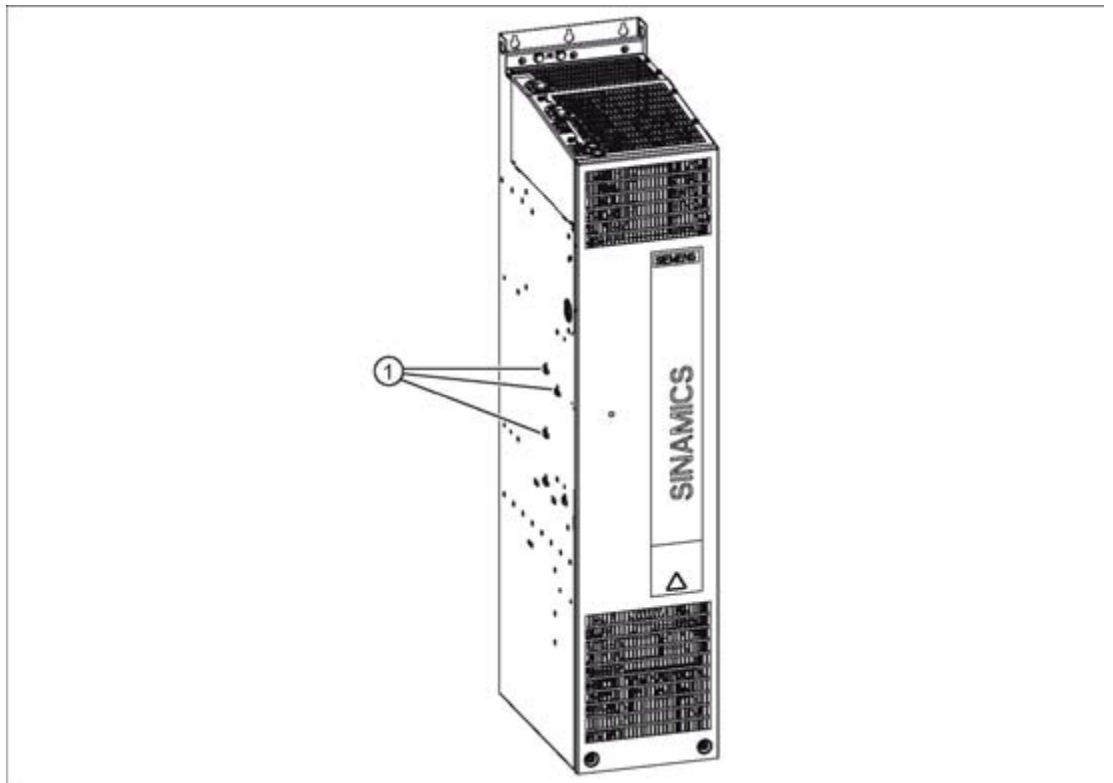

① Holders to retain the Control Unit

Figure 2-16 Installing the CU320-2 DP directly on a Line Module in chassis format

Installing the CU320-2 DP directly on a mounting surface

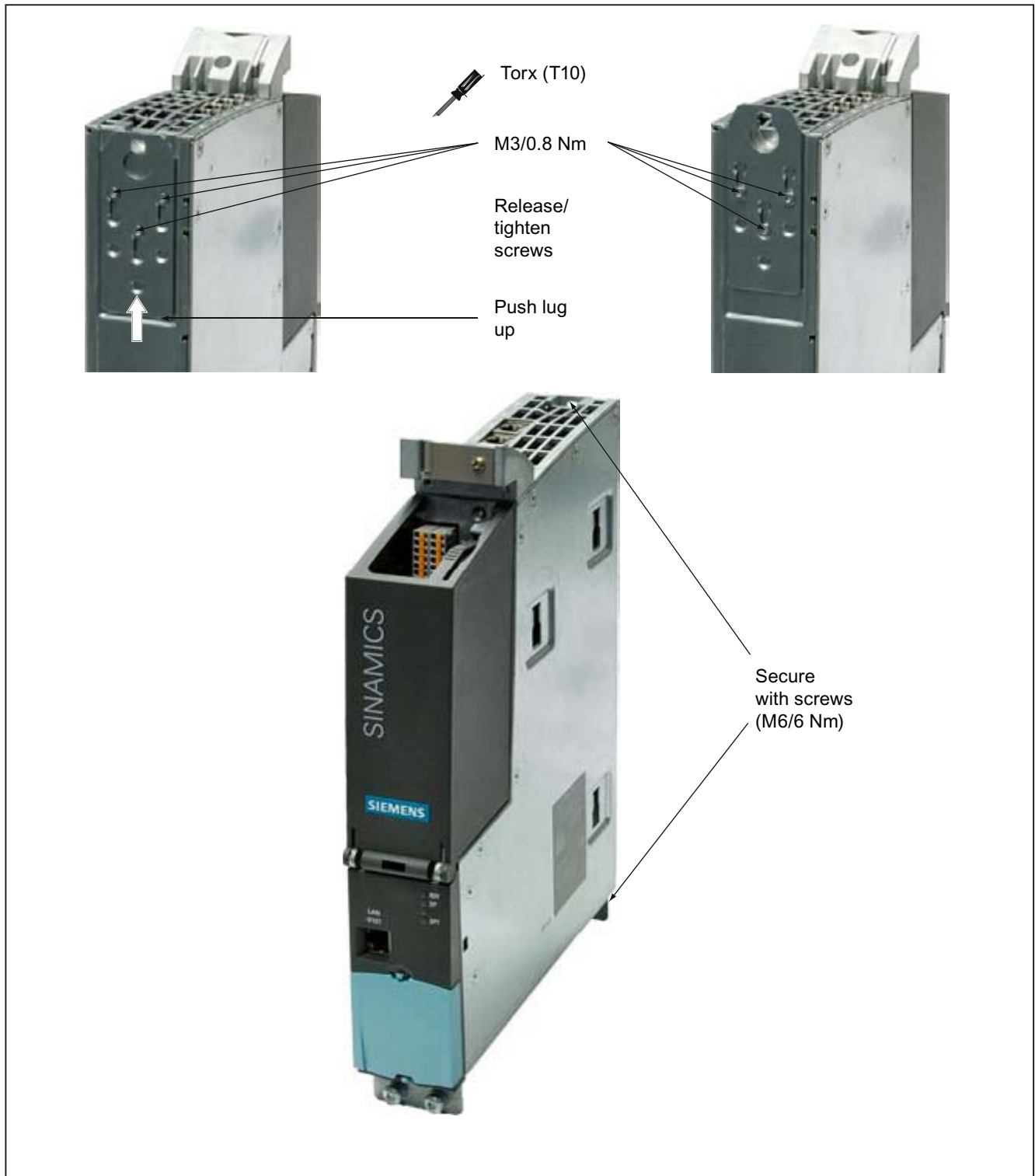

Figure 2-17 Installing the CU320-2 DP on a mounting surface

Installing the CU320-2 DP on a mounting surface using spacer elements

To increase the mounting depth of the Control Unit to the 270 mm mounting depth of a Line Module in booksize format, spacer elements (2 pieces: 6SL3064-1BB00-0AA0) can be installed.

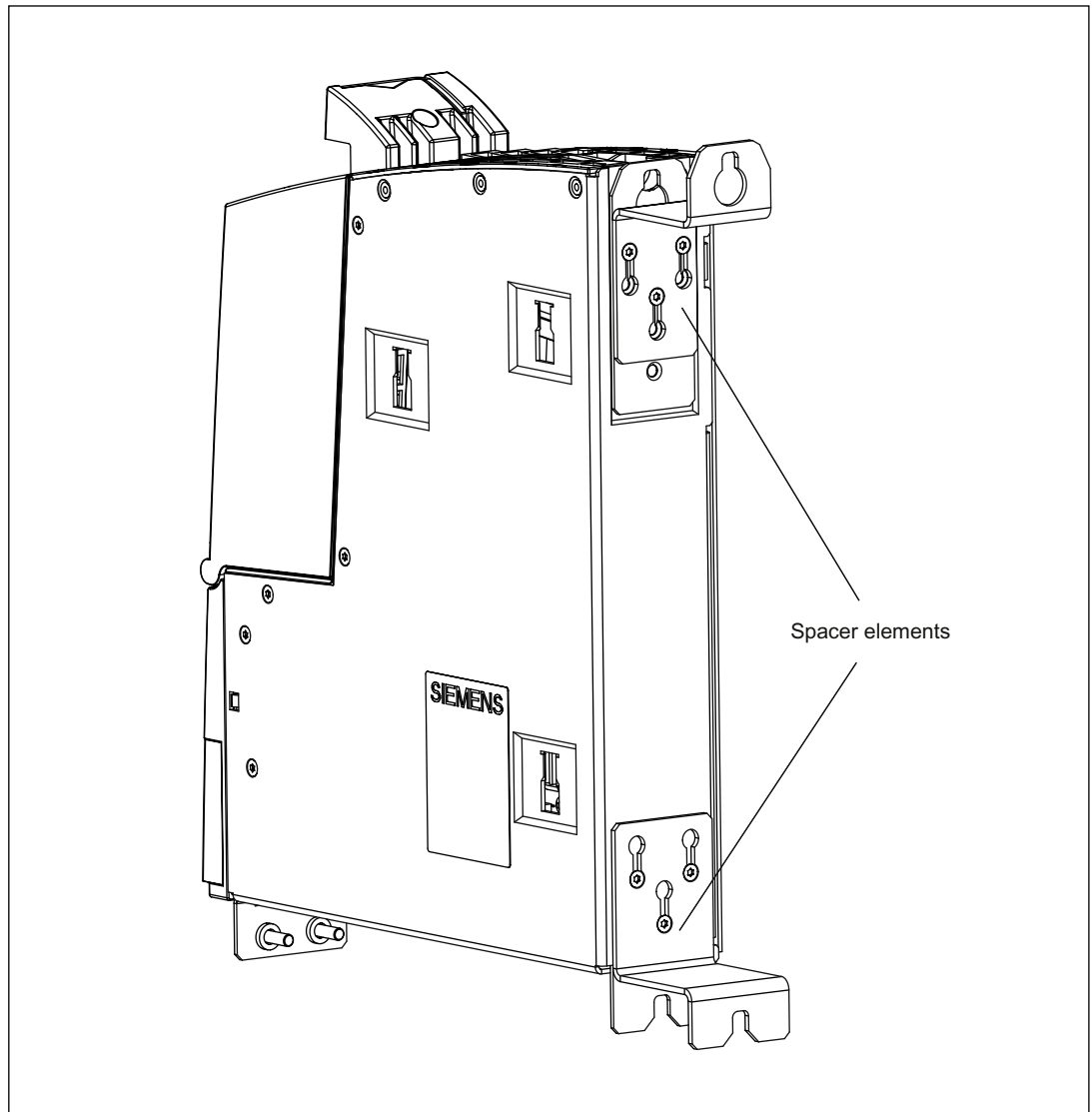

Figure 2-18 Installing the CU320-2 DP on a mounting surface using spacer elements

Removing/opening the cover of the CU320-2 DP

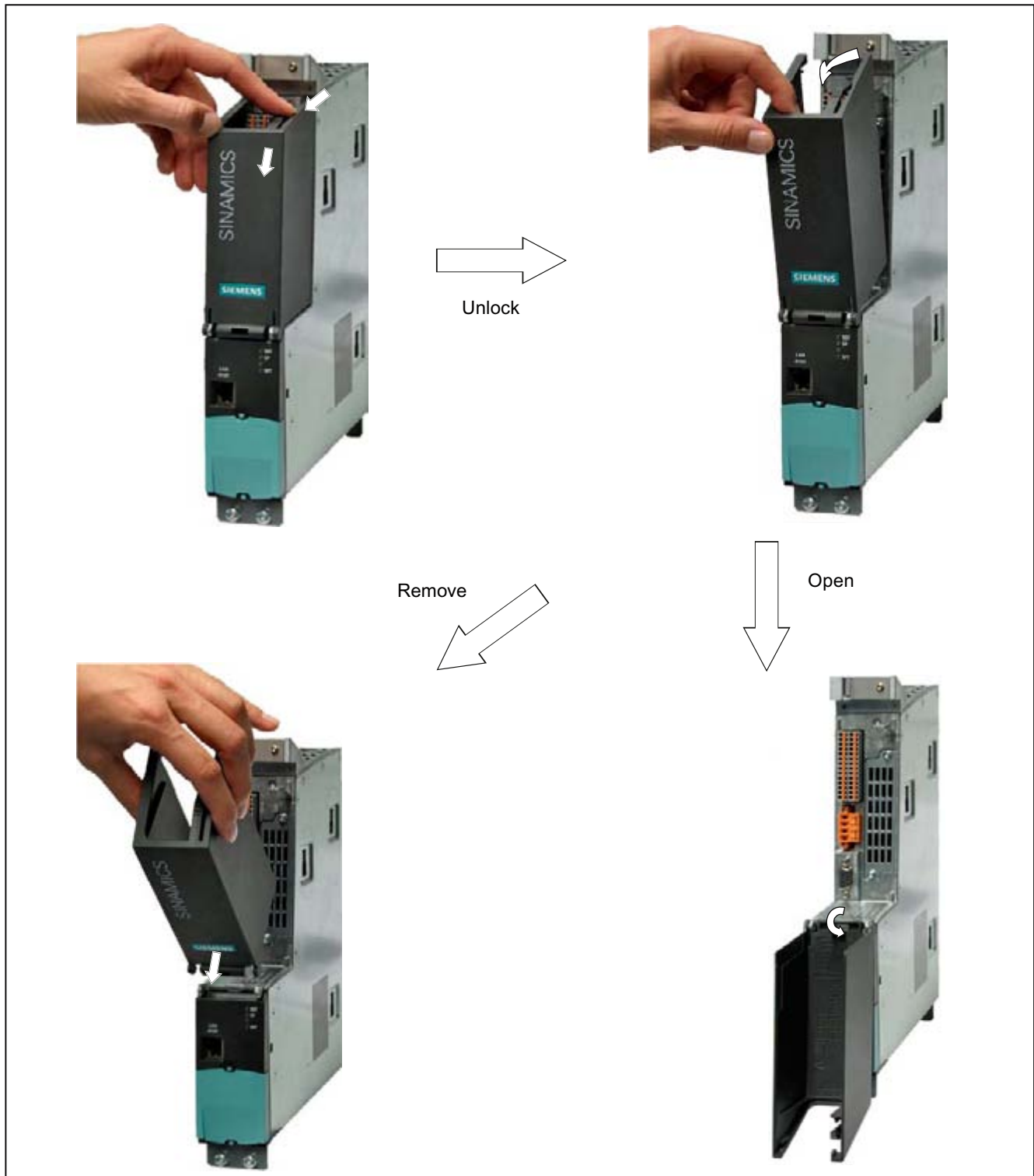

Figure 2-19 Removing/opening the cover of the CU320-2 DP

2.3.6 Technical data

Table 2- 31 Technical data

6SL3040-1MA00-0AA1	Unit	Value
Electronics power supply		
Voltage	V _{DC}	24 DC (20.4 to 28.8)
Current (without DRIVE-CLiQ or digital outputs)	A _{DC}	1.0
Power loss	W	24
Maximum DRIVE-CLiQ cable length	m	100
PE/ground connection	On housing with M5/3 Nm screw	
Response time	The response time of digital inputs/outputs depends on the evaluation (refer to the function diagram). References: /LH1/SINAMICS S120 List Manual, Chapter "Function diagrams".	
Weight	kg	2.3

Additional system components

3.1 Basic Operator Panel BOP20

3.1.1 Description

The Basic Operator Panel BOP20 contains six keys and a backlit display unit. The BOP20 can be plugged onto a SINAMICS Control Unit and operated.

The following functions are possible with the BOP:

- Input of parameters and activation of functions
- Display of operating modes, parameters, alarms and faults

3.1.2 Interface description



Figure 3-1 Basic Operator Panel BOP20

Overview of displays and keys

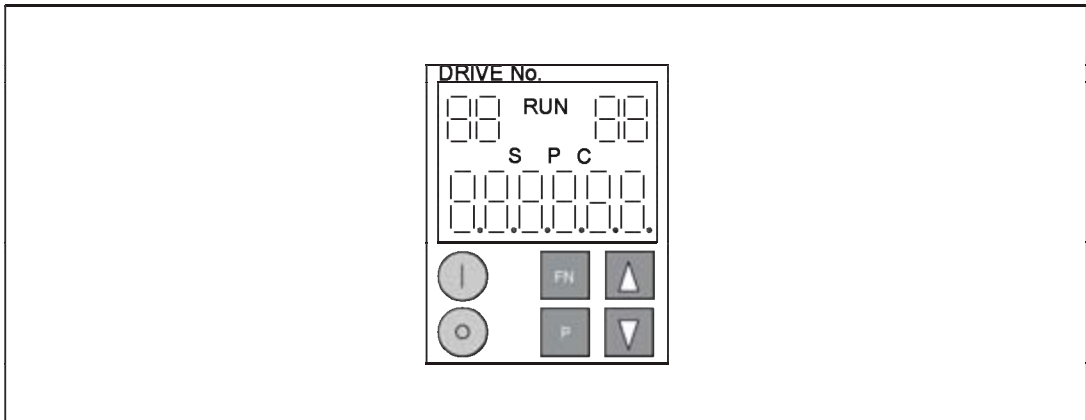







Figure 3-2 Overview of displays and keys

Table 3- 1 Displays

Display	Meaning
top left 2 positions	The active drive object of the BOP is displayed here. The displays and key operations always refer to this drive object.
RUN	Is lit (bright) if the displayed drive is in the RUN state (in operation).
top right 2 positions	The following is displayed in this field: <ul style="list-style-type: none"> • More than 6 digits: Characters that are present but cannot be seen (e.g. "r2" → 2 characters to the right are invisible, "L1" → 1 character to the left is invisible) • Faults: Selects/displays other drives with faults • Designation of BICO inputs (bi, ci) • Designation of BICO outputs (bo, co) Source object of a BICO interconnection to a drive object different than the active one.
S	Is (bright) if at least one parameter was changed and the value was not transferred into the non-volatile memory.
P	Is lit (bright) if, for a parameter, the value only becomes effective after pressing the P key.
C	Is light (bright) if at least one parameter was changed and the calculation for consistent data management has still not been initiated.
Below, 6 position	Displays, e.g. parameters, indices, faults and alarms.

BOP20 keyboard

Table 3- 2 Assignment of the BOP20 keyboard

Key	Name	Meaning
	ON	Powering-up the drives for which the command "ON/OFF1", "OFF2" or "OFF3" should come from the BOP.
	OFF	Powering-down the drives for which the commands "ON/OFF1", "OFF2" or "OFF3" should come from the BOP.
		<p>Note:</p> <p>The effectiveness of these keys can be defined using the appropriate BICO parameterization (e.g. using these keys, it is possible to simultaneously control all of the axes that have been configured).</p> <p>The structure of the BOP control word corresponds to the structure of the PROFIBUS control word.</p>
	Functions	<p>The meaning of these keys depends on the actual display.</p> <p>Note:</p> <p>The effectiveness of this key to acknowledge faults can be defined using the appropriate BiCo parameterization.</p>
	Parameter	The meaning of these keys depends on the actual display.
	Raise	The keys are dependent on the actual display and are used to raise or lower values.
	Lower	

Displays and operating the BOP20

Information about the displays and using the BOP20 is provided in the following reference:

Reference: /IH1/ SINAMICS S120 Commissioning Manual

3.1.3 Installation

Table 3- 3 Installation on the CU320-2 DP









	
<p>1. CU320-2 DP and BOP20</p>	<p>2. Remove the cover by pressing the latching cams together</p>
	
<p>3. Insert the CompactFlash card before inserting the BOP20</p>	<p>4. Carefully insert the BOP20 until you hear it latch into position</p>

Table 3- 4 Installation on the CU320

	
<p>1. CU320 and BOP20</p>	<p>2. Press the latching cams of the cover together</p>
	
<p>3. Remove the cover</p>	<p>4. Carefully insert the BOP20 until you hear it latch into position</p>

3.1.4 Removal

Please note the following information when removing the BOP20 from the CU320 or the CU320-2 DP:

1. The latching cams on the BOP20 must be pressed together simultaneously.
2. The BOP20 must be pulled out straight (i.e. not at an angle). The bottom edge of the BOP20 must never be pulled forwards to remove the device, as this could damage the interface on the rear.



Figure 3-3 **Incorrect removal** of the BOP20 from a CU320-2 DP (example)

3.2 Option Board: CAN Communication Board CBC10

3.2.1 Description

The Communication Board CBC10 is a communication module for linking to CAN.

3.2.2 Safety information

CAUTION
The Option Board should only be inserted and removed when the Control Unit and Option Board are at zero current.

CAUTION
The CBC10 must only be operated by qualified personnel. The ESC notices must be observed.

3.2.3 Interface description

3.2.3.1 Overview

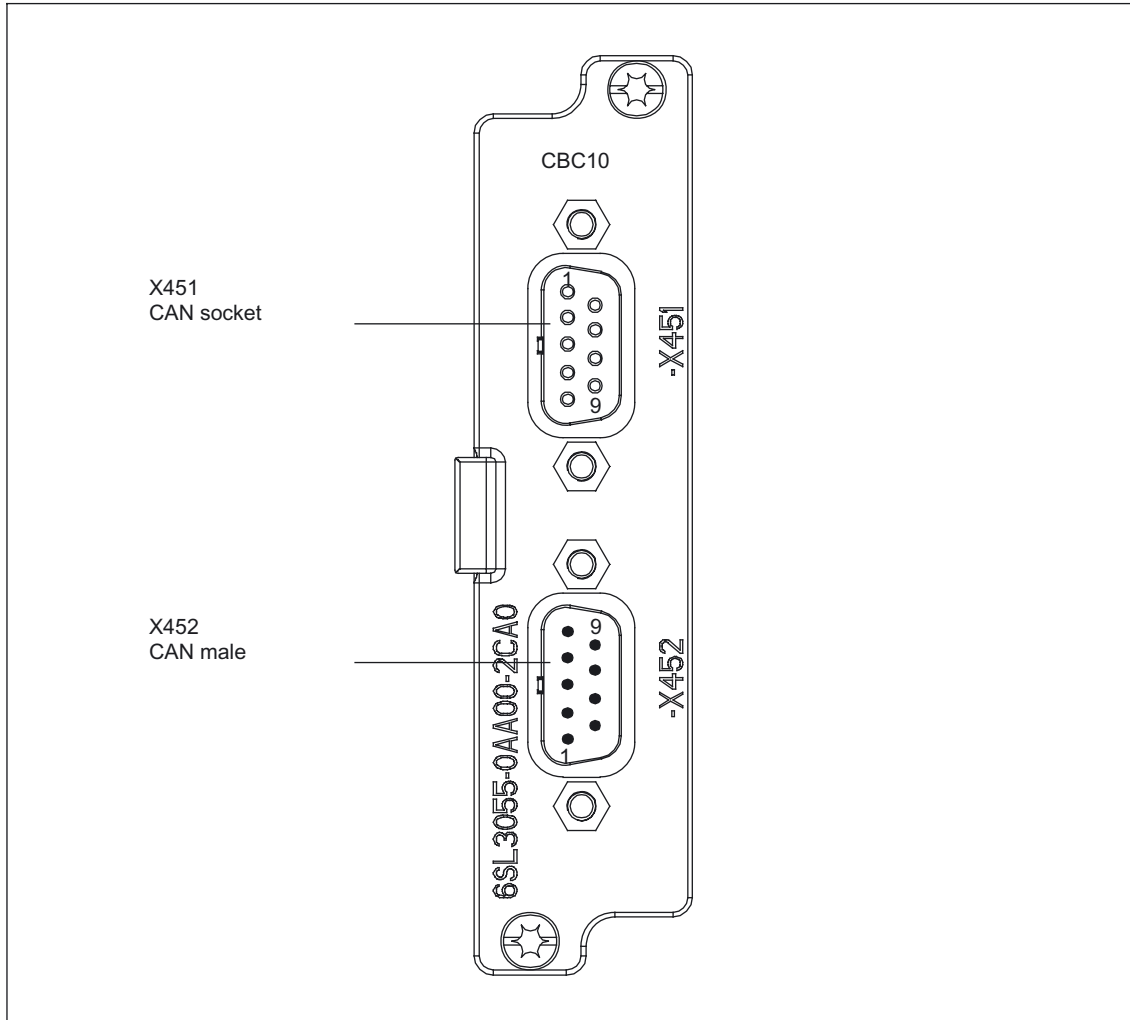
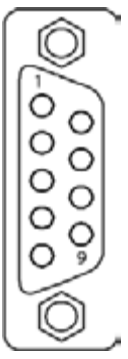

Figure 3-4 Interface description of the CBC10

3.2.3.2 CAN bus interface X451

Table 3- 5 CAN bus interface X451

	Pin	Designation	Technical specifications
	1	Reserved, do not use	
	2	CAN_L	CAN signal (dominant low)
	3	CAN_GND	CAN ground
	4	Reserved, do not use	
	5	CAN_SHLD	Optional shield
	6	GND	CAN ground
	7	CAN_H	CAN signal
	8	Reserved, do not use	
	9	Reserved, do not use	

Type: SUB-D female, 9-pin

⚠ CAUTION
 If the CAN bus interface is connected to the PROFIBUS connector, then this can destroy the CAN interface.

3.2.3.3 CAN bus interface X452

Table 3- 6 CAN bus interface X452

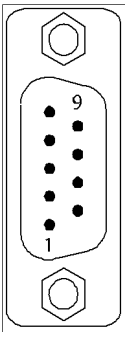
	Pin	Name	Technical specifications
	1	Reserved, do not use	
	2	CAN_L	CAN signal (dominant low)
	3	CAN_GND	CAN ground
	4	Reserved, do not use	
	5	CAN_SHLD	Optional shield
	6	GND	CAN ground
	7	CAN_H	CAN signal
	8	Reserved, do not use	
	9	Reserved, do not use	

Type: 9-pin SUB-D male

3.2.3.4 2-pin SMD DIL switch

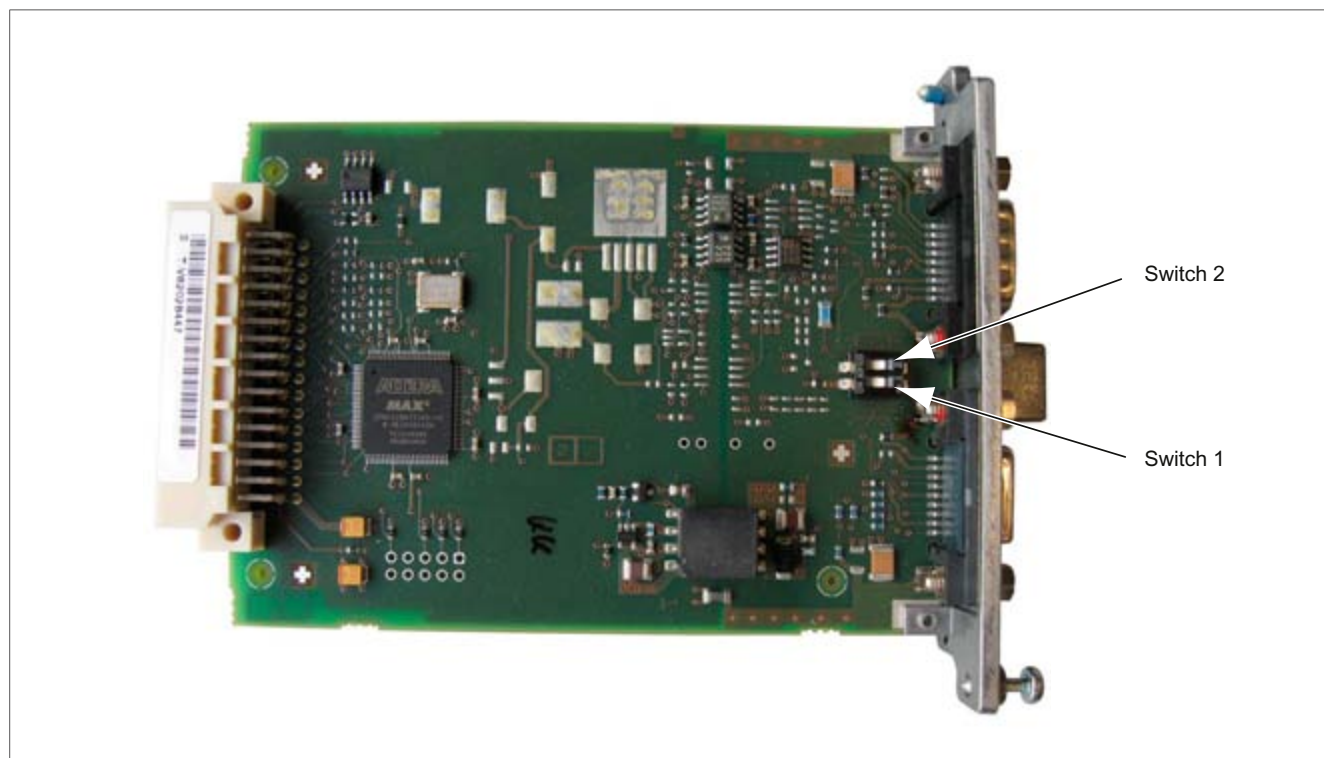

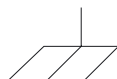

Figure 3-5 Switch 2/1

Table 3-7 2-pin SMD DIL switch

ID on the component	Switch	Function	Switch position		Default
	2	Bus terminating resistor 120 Ohm	Off	Inactive	Off
			ON	Active	
	1	Operation with/without ground	Off	Ground-free operation	Off
			ON	Operation with ground	

3.2.3.5 Meaning of the LED

Table 3- 8 Communication Board CAN CBC10 – Description of the LEDs

LED	Color	Status	Description, cause	Remedy
OPT on the Control Unit	–	OFF	Electronics power supply is missing or outside permissible tolerance range. Communication Board either defective or not inserted.	–
	Green	Continuous light	OPERATIONAL	–
		Flashing light	PREOPERATIONAL No PDO communication possible	–
		Single flash	STOPPED Only NMT communication possible	
	Red	Continuous light	BUS OFF	Check baud rate Check cabling
		Single flash	ERROR PASSIVE MODE The error counter for "error passive" has reached the value 127. After the SINAMICS drive system was booted no further active CAN component was on the bus.	Check baud rate Check cabling
		Double flash	Error Control Event, a Guard Event has occurred	Check connection to CANopen master

3.2.4 Installation

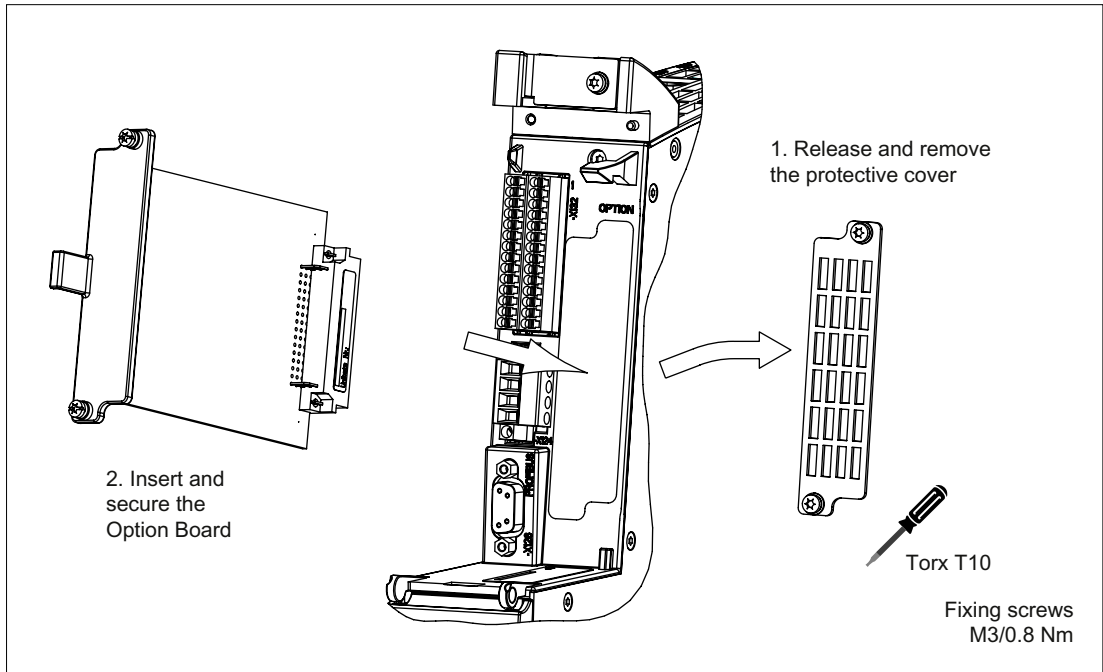

Figure 3-6 Installing an Option Board in a CU320-2 DP

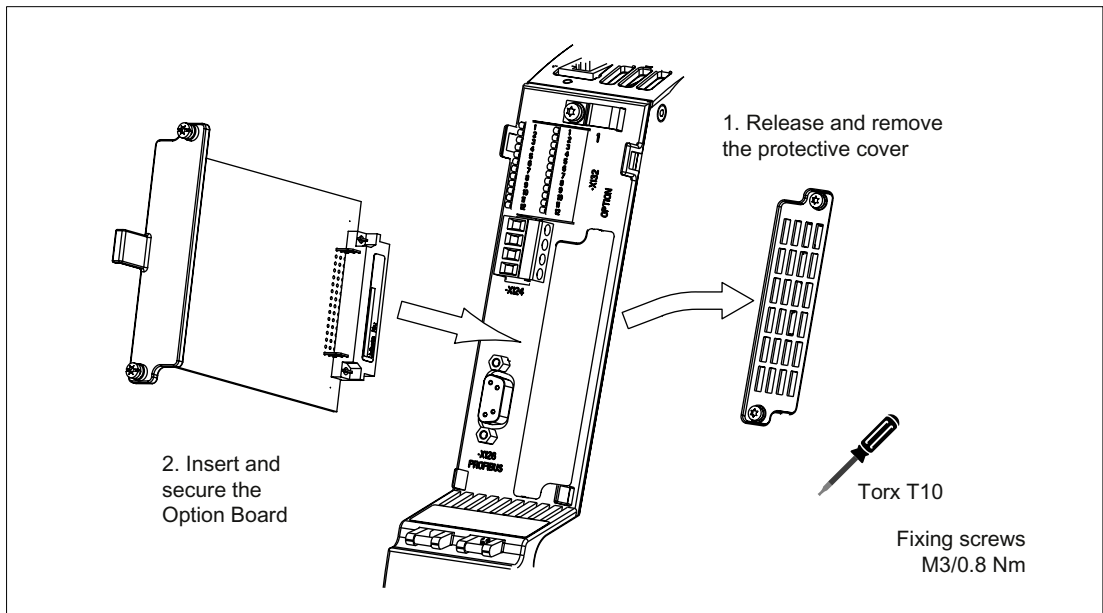

Figure 3-7 Installing an Option Board in a CU320

3.2.5 Technical data

Table 3-9 Technical data

6SL3055-0AA00-2CAx	Unit	Value
Max. current requirements (at 24 V DC)	A _{DC}	0.1
Power loss	W	<10
Weight, approx.	kg	0.1

3.3 Option Board: Communication Board Ethernet CBE20

3.3.1 Description

The SINAMICS S120 system can be connected to PROFINET using the Communication Board CBE20 interface board. The CBE20 permits PROFINET IO with IRT support and PROFINET IO with RT support. Mixed operation is not permissible! PROFINET CBA is not supported.

3.3.2 Safety information

CAUTION

The Option Board should only be inserted and removed when the Control Unit and Option Board are at zero current.

CAUTION

The CBE20 must only be operated by qualified personnel. The ESC notices must be observed.

3.3.3 Interface description

3.3.3.1 Overview

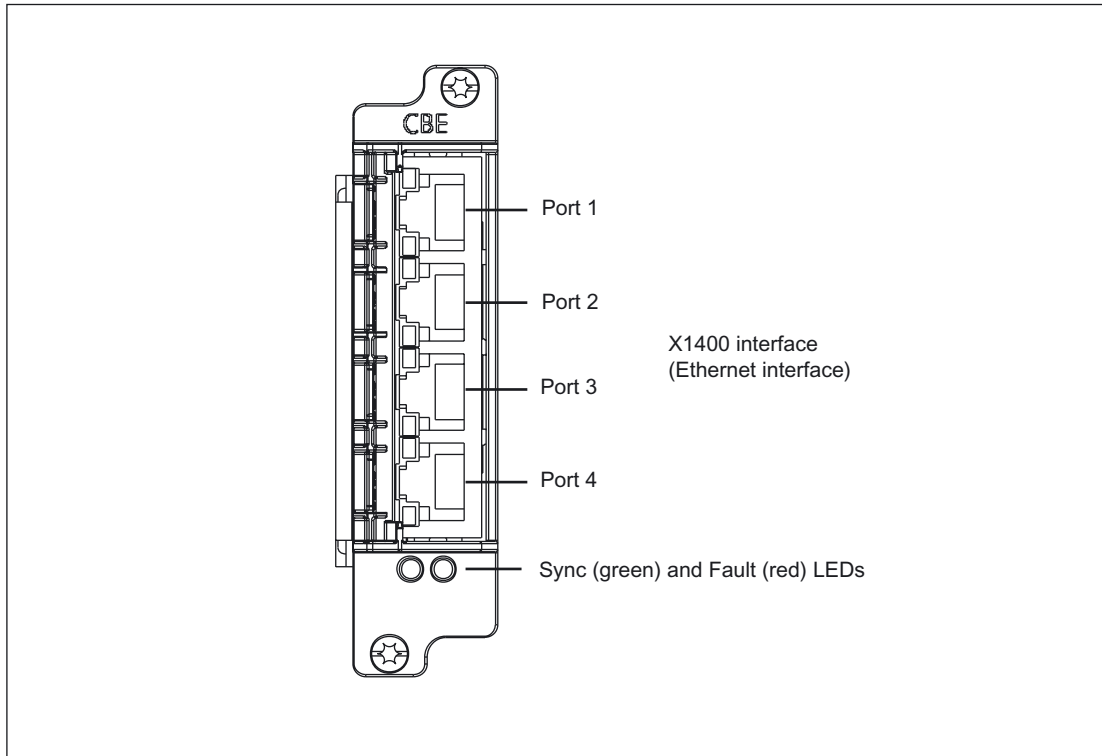

Figure 3-8 Interface description CBE20

MAC address

The MAC address of the Ethernet interface is indicated on the upper side of the board. The label is only visible when the Option Board has been removed.

3.3.3.2 X1400 Ethernet interface

Table 3- 10 X1400 Port 1-4

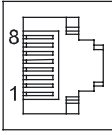
	Pin	Signal name	Technical specifications
	1	RX+	Receive data +
	2	RX-	Receive data -
	3	TX+	Transmit data +
	4	---	Reserved, do not use
	5	---	Reserved, do not use
	6	TX-	Transmit data -
	7	---	Reserved, do not use
	8	---	Reserved, do not use
	Screened backshell	M_EXT	Screen, permanently connected

PROFINET

Cable and connector types

Information on PROFINET cables and connectors can be found in the following catalog:

Catalog IKPI, edition 2005

Industrial Communication for Automation and Drives

Order No. E86060-K6710-A101-B4

3.3.3.3 Meaning of the LEDs on the CBE20 Communication Board Ethernet

Table 3- 11 Communication Board Ethernet CBE20 – description of the LEDs

LED	Color	Status	Description, cause	Remedy
Link port	-	Off	Electronics power supply is missing or outside permissible tolerance range.	-
	Green	Continuous light	A different device is connected to port x and a physical connection exists.	-
Activity port	-	Off	Electronics power supply is missing or outside permissible tolerance range.	-
	Yellow	Continuous light	Data is being received or sent at port x.	-
Fault	-	Off	If the Link Port LED is green: The CBE20 is operating normally, data is being exchanged with the configured IO Controller	-
	Red	Flashing	<ul style="list-style-type: none"> The response monitoring interval has elapsed. Communications is interrupted. The IP address is incorrect. Incorrect or no configuration. Incorrect parameter settings. Incorrect or missing device name. IO Controller not connected/switched off, although an Ethernet connection has been established. Other CBE20 errors 	-
		Continuous light	CBE20 bus error <ul style="list-style-type: none"> No physical connection to a subnet/switch. Incorrect transmission rate Full duplex transmission is not activated. 	-
Sync	-	Off	If the Link Port LED is green: Control Unit task system is not synchronized with the IRT clock. An internal substitute clock is generated.	-
	Green	Flashing light	The Control Unit task system has synchronized with the IRT clock cycle and data is being exchanged.	-
		Continuous light	Task system and MC-PLL have synchronized with the IRT clock.	-
OPT on the Control Unit	-	OFF	Electronics power supply is missing or outside permissible tolerance range. Communication Board either defective or not inserted.	-
	Green	Continuous light	Communication Board is ready and cyclic communication is taking place.	-
		0.5 Hz flashing light	The Communication Board is ready, but cyclic communication is not yet taking place. Possible causes: <ul style="list-style-type: none"> At least one fault is present. Communication is being established. 	-

LED	Color	Status	Description, cause	Remedy
	Red	Continuous light	Cyclic communication via PROFINET has not yet been established. However, non-cyclic communications are possible. SINAMICS waits for a parameterizing/configuring telegram	–
		0.5 Hz flashing light	The firmware has not been successfully downloaded to the CBE20 (error). Possible causes: <ul style="list-style-type: none"> • The CBE20 is defective. • The memory card for the Control Unit is defective. In this state CBE20 cannot be used.	–
		2.5 Hz flashing light	Communication between the Control Unit and CBE20 is faulty. Possible causes: <ul style="list-style-type: none"> • Board was withdrawn after booting. • The board is defective 	Correctly insert the board, if required, replace.
	Orange	2.5 Hz flashing light	Firmware is being downloaded.	–

3.3.4 Installation

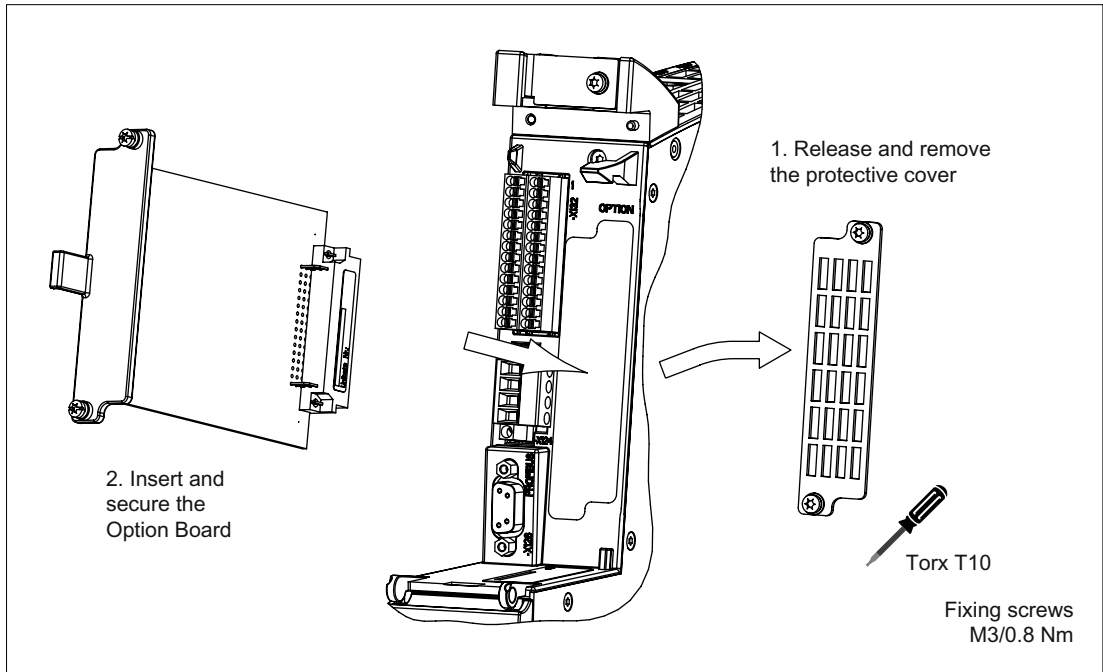

Figure 3-9 Installing the Option Board in a CU320-2 DP

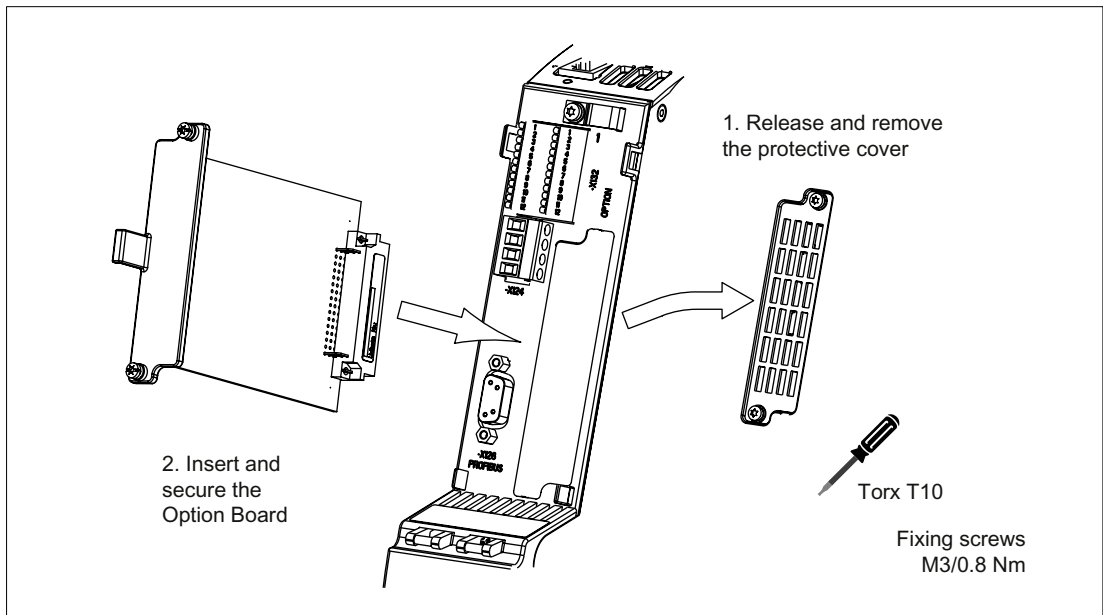

Figure 3-10 Installing the Option Board in a CU320

3.3.5 Technical specifications

Table 3- 12 Technical specifications

Communication Board CBE20 6SL3055-0AA00-2EBx	Unit	Value
Max. current requirements (at 24 V DC)	A _{DC}	0.1
Power loss	W	3
Weight	kg	<0.1

3.4 Option Board: Terminal Board TB30

3.4.1 Description

The Terminal Board TB30 is a terminal expansion board for plugging onto the Control Unit.
 The TB30 contains the following terminals:

Table 3- 13 Interface overview of the TB30

Type	Quantity
Digital inputs	4
Digital outputs	4
Analog inputs	2
Analog outputs	2

3.4.2 Safety information

CAUTION
The Option Board should only be inserted and removed when the Control Unit and Option Board are at zero current.

CAUTION
The TB30 must only be operated by qualified personnel. The ESC notices must be observed.

3.4.3 Interface description

3.4.3.1 Overview

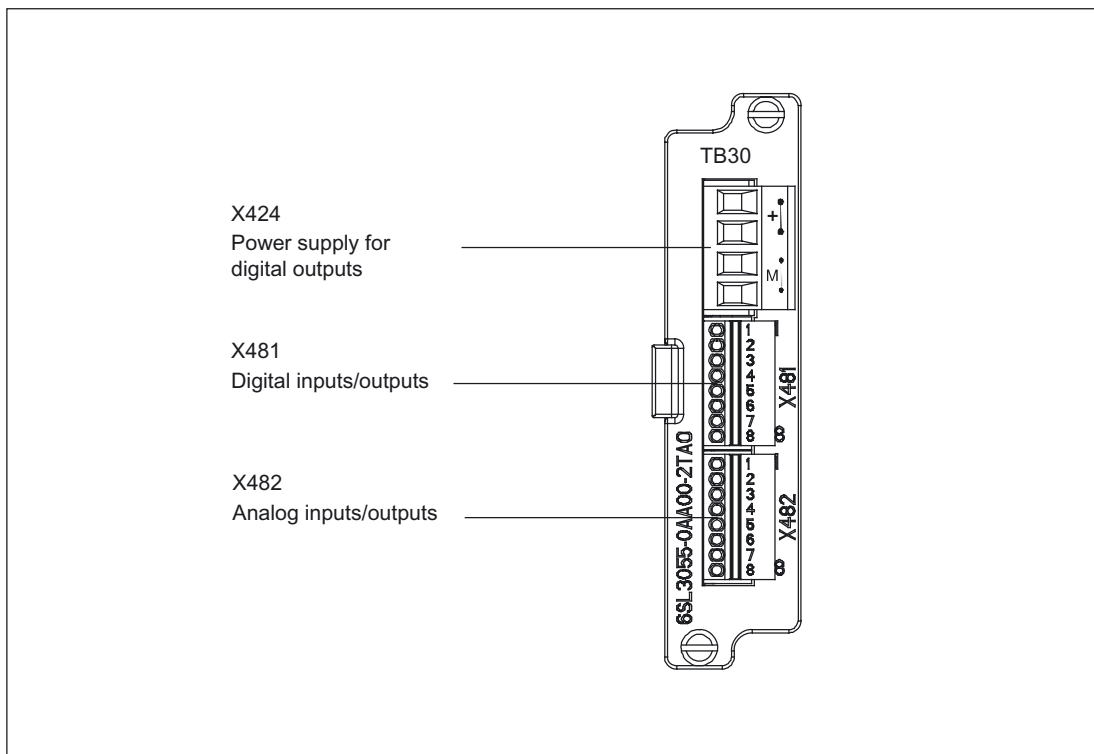

Figure 3-11 Interface description of the TB30

3.4.3.2 Connection example

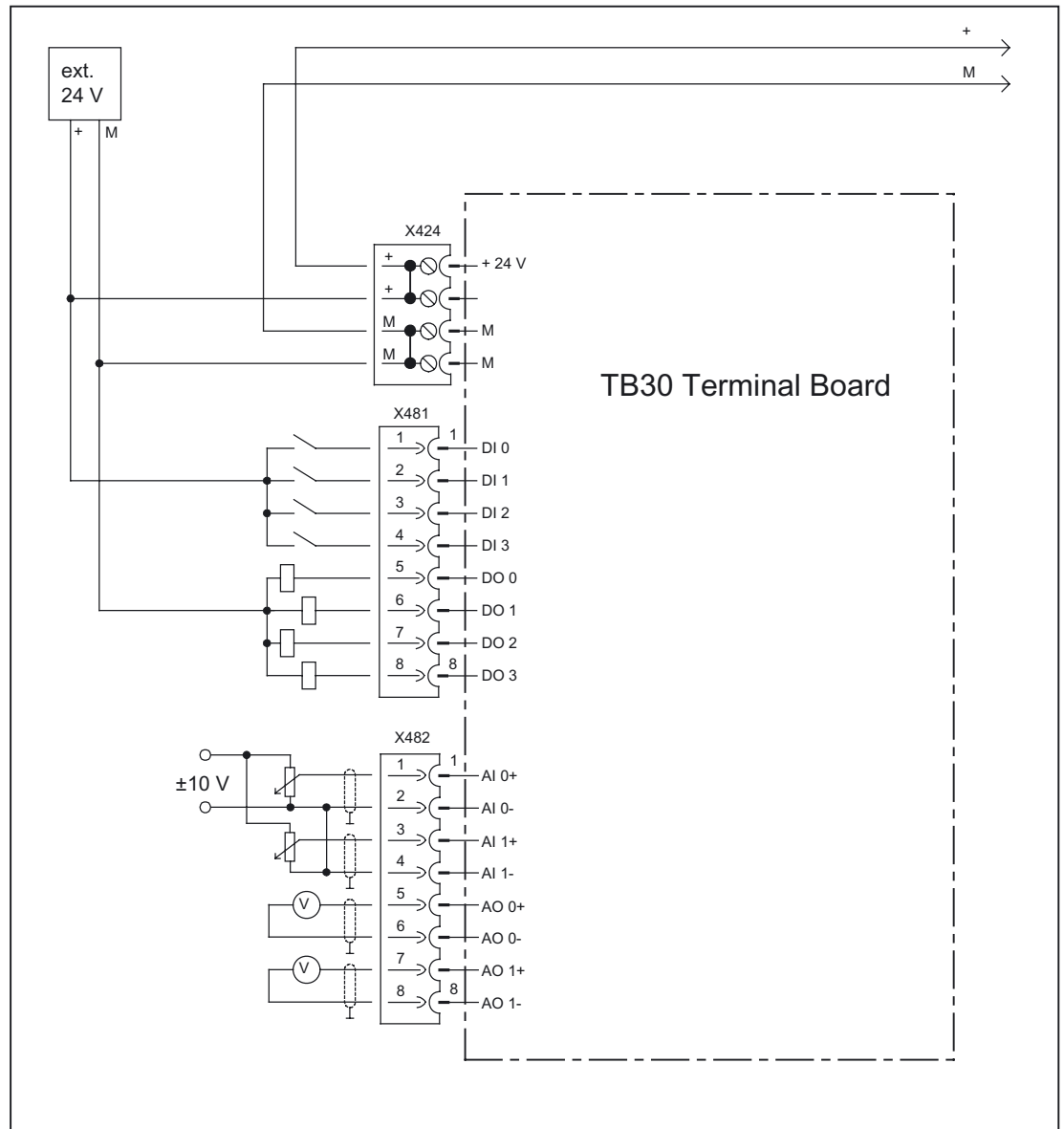
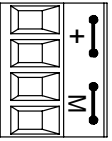

Figure 3-12 Example connection of TB30

3.4.3.3 X424 power supply, digital outputs

Table 3- 14 Terminal block X424

	Terminal	Designation	Technical specifications
	+	Power supply	Voltage: 24 V DC (20.4 V – 28.8 V) Current consumption: Max. 4 A (per digital output max. 0.5 A) Max. current via jumper in connector: 20 A
	+	Power supply	
	M	Ground	
	M	Ground	
Max. connectable cross-section: 2.5 mm ² Type: Screw terminal 2 (see Appendix A)			

Note

The two "+" and "M" terminals are jumpered in the connector. This ensures that the supply voltage is looped through.

This power supply is required for the digital outputs only. The electronics power supply and the power supply for the analog inputs/outputs are drawn via the option slot of the Control Unit.

Note

The power supply of the digital outputs and the electronics power supply of the Control Unit are isolated.

Note

If the 24 V supply is briefly interrupted, then the digital outputs are deactivated during this time.

3.4.3.4 X481 Digital inputs/outputs

Table 3- 15 Terminal block X481

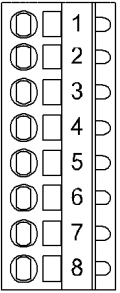
	Terminal	Designation ¹⁾	Technical specifications
	1	DI 0	Voltage: - 3 V to 30 V Typical current consumption: 10 mA at 24 V DC Ground reference: X424. M Input delay: - for "0" to "1": 20 µs - for "1" to "0": 100 µs Level (incl. ripple) High level: 15 V to 30 V Low level: -3 V to 5 V
	2	DI 1	
	3	DI 2	
	4	DI 3	
	5	DO 0	Voltage: 24 VDC Max. load current per output: 500 mA Reference ground: X424.M Sustained short-circuit-proof Output delay: - for "0" to "1": Typically 150 µs at 0.5 A ohmic load (500 µs maximum) - for "1" to "0": Typically 50 µs at 0.5 A ohmic load Switching frequency: For resistive load: Max. 100 Hz For inductive load: Max. 0.5 Hz For lamp load: Max. 10 Hz Maximum lamp load: 5 W
	6	DO 1	
	7	DO 2	
	8	DO 3	
Max. connectable cross-section: 0.5 mm ² Type: Spring-loaded terminal 1 (see Appendix A)			

1) DI: digital input, DO: digital output

Note

An open input is interpreted as "low".

The power supply and the digital inputs/outputs are isolated from the Control Unit.

Note

If the 24 V supply is briefly interrupted, then the digital outputs are deactivated during this time.

3.4.3.5 X482 Analog inputs/outputs

Table 3- 16 Terminal block X482

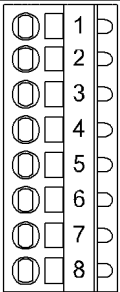
	Terminal	Designation ¹⁾	Technical specifications
	1	AI 0+	Analog inputs (AI) Voltage: -10 V to +10 V Internal resistance: 65 kΩ Resolution: 13 bits + sign
	2	AI 0-	
	3	AI 1+	
	4	AI 1-	
	5	AO 0+	Analog outputs (AO) Voltage range: -10 V to +10 V Load current: max. -3 mA to +3 mA Resolution: 11 bit + sign Continuously short-circuit proof
	6	AO 0-	
	7	AO 1+	
	8	AO 1-	
Max. connectable cross-section: 0.5 mm ² Type: Spring-loaded terminal 1 (see Appendix A)			

1) AI: analog input, AO: analog output

Note

An open input is interpreted as approximately "0 V".

The power supply of the analog inputs/outputs is drawn via the option slot of the Control Unit and not via X424.

The shield is connected to the Control Unit (refer to Chapter "Electrical Connection").

CAUTION

The common-mode range must not be infringed.

The analog differential voltage signals can have a maximum offset voltage of +/-30 V with respect to the ground potential. If the range is infringed, incorrect results may occur during analog/digital conversion.

Handling analog inputs

The following reference contains more information about analog inputs:

References: /IH1/ SINAMICS S120 Commissioning Manual

3.4.4 Installation

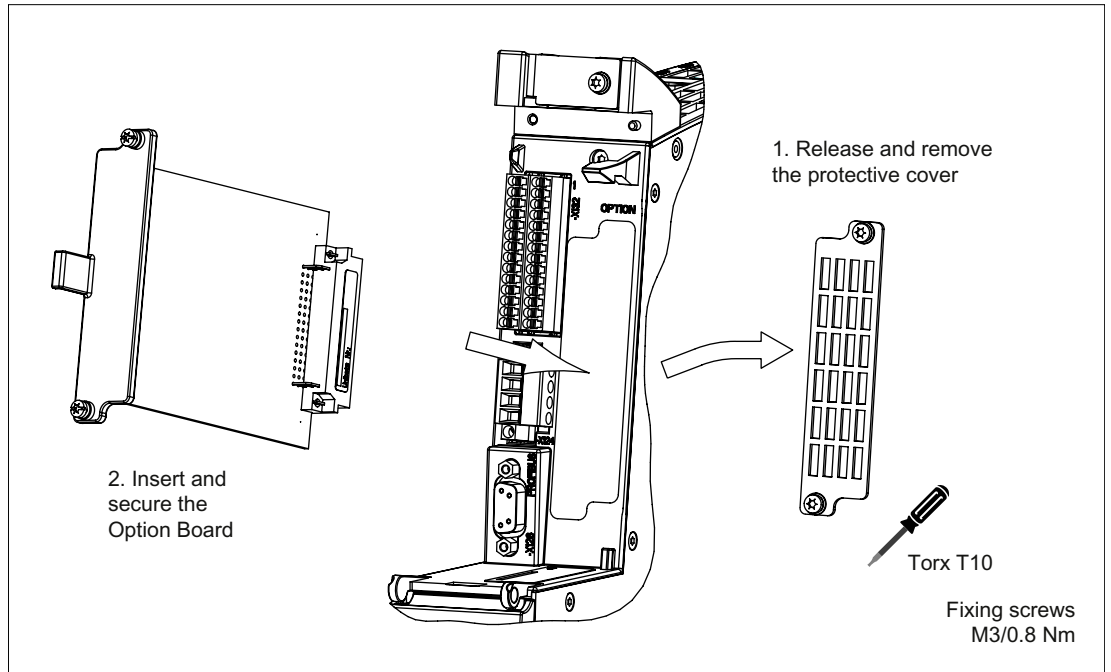

Figure 3-13 Installing an Option Board in a CU320-2 DP

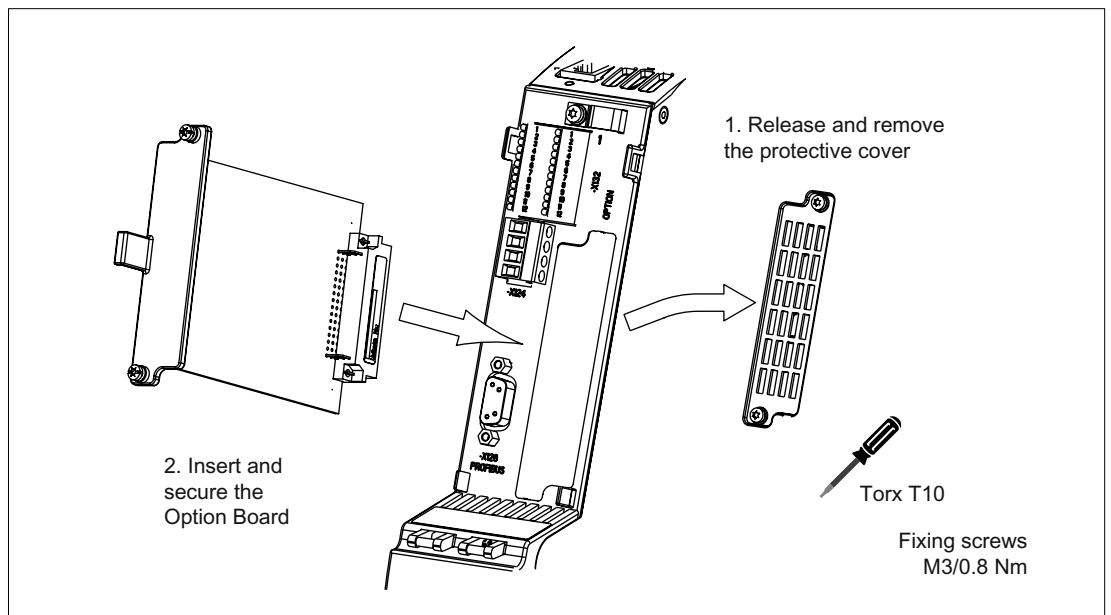

Figure 3-14 Installing an Option Board in a CU320

3.4.5 Shield support

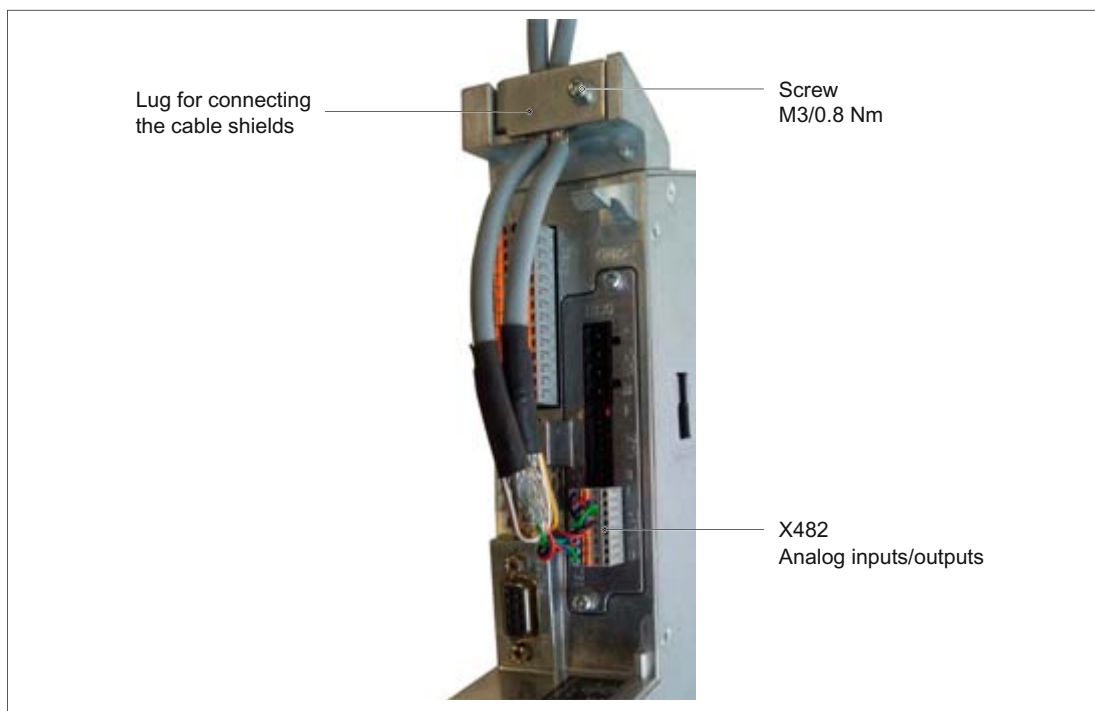

Figure 3-15 Shield support for TB30 on the CU320-2 DP

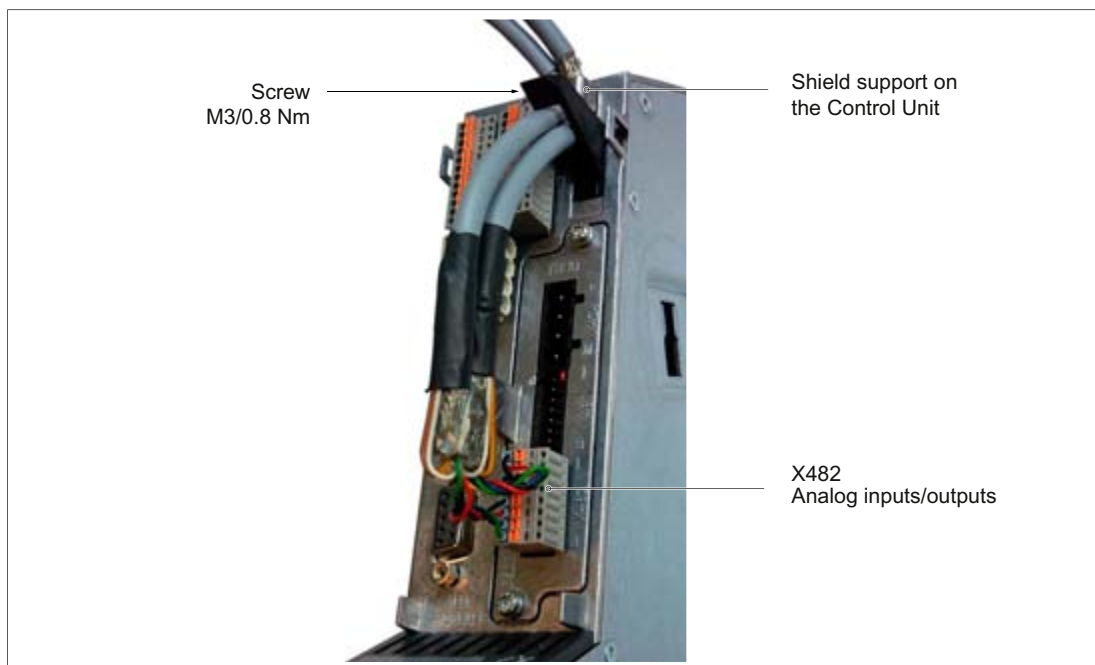

Figure 3-16 Shield support for TB30 on the CU320

The permissible bending radii for the cables must not be exceeded when the cables are being installed.

3.4.6 Technical data

Table 3- 17 Technical data

3SL3055-0AA00-2TAx	Unit	Value
Electronics power supply		
Voltage	V _{DC}	24 DC (20.4 – 28.8)
Current via the option slot of the CU (without digital outputs)	A _{DC}	0.05
Power loss	W	<3
Response time	The response time of digital inputs/outputs and analog inputs/outputs depends on the evaluation on the Control Unit (see function diagram). References: SINAMICS S List Manual – "Function diagrams" chapter	
Weight	kg	0.1

3.5 Terminal Module TM15

3.5.1 Description

The Terminal Module TM15 is a terminal expansion for snapping on to an EN 60715 DIN rail. The TM15 can be used to increase the number of available digital inputs/outputs within a drive system.

Table 3- 18 Interface overview of the TM15

Type	Quantity
Digital inputs/outputs	24 (electrical isolation in 3 groups each with 8 DI/O)

3.5.2 Safety information

 WARNING
The ventilation spaces of 50 mm above and below the component must be observed.

3.5.3 Interface description

3.5.3.1 Overview

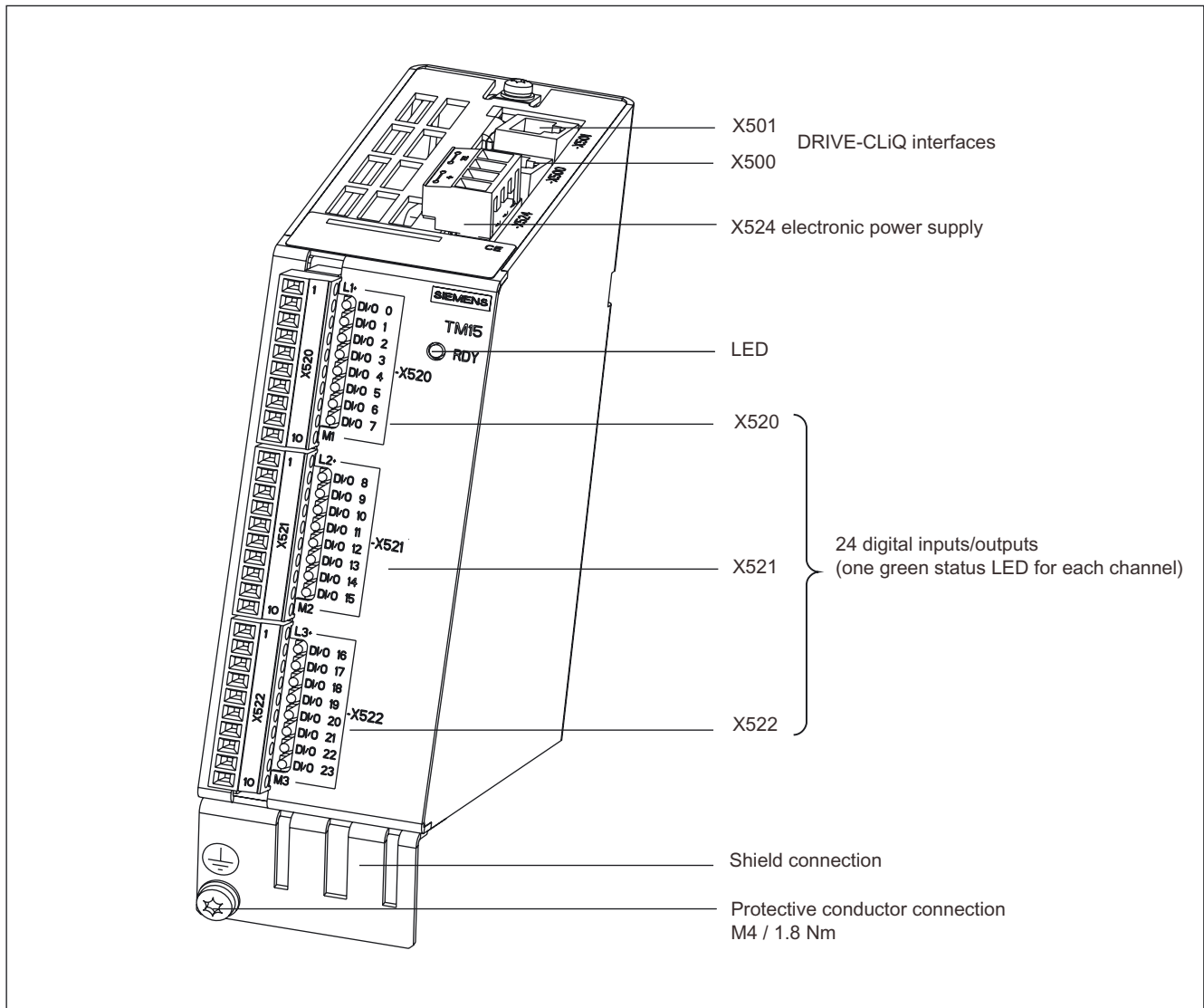

Figure 3-17 Interface description TM15

3.5.3.2 Connection example

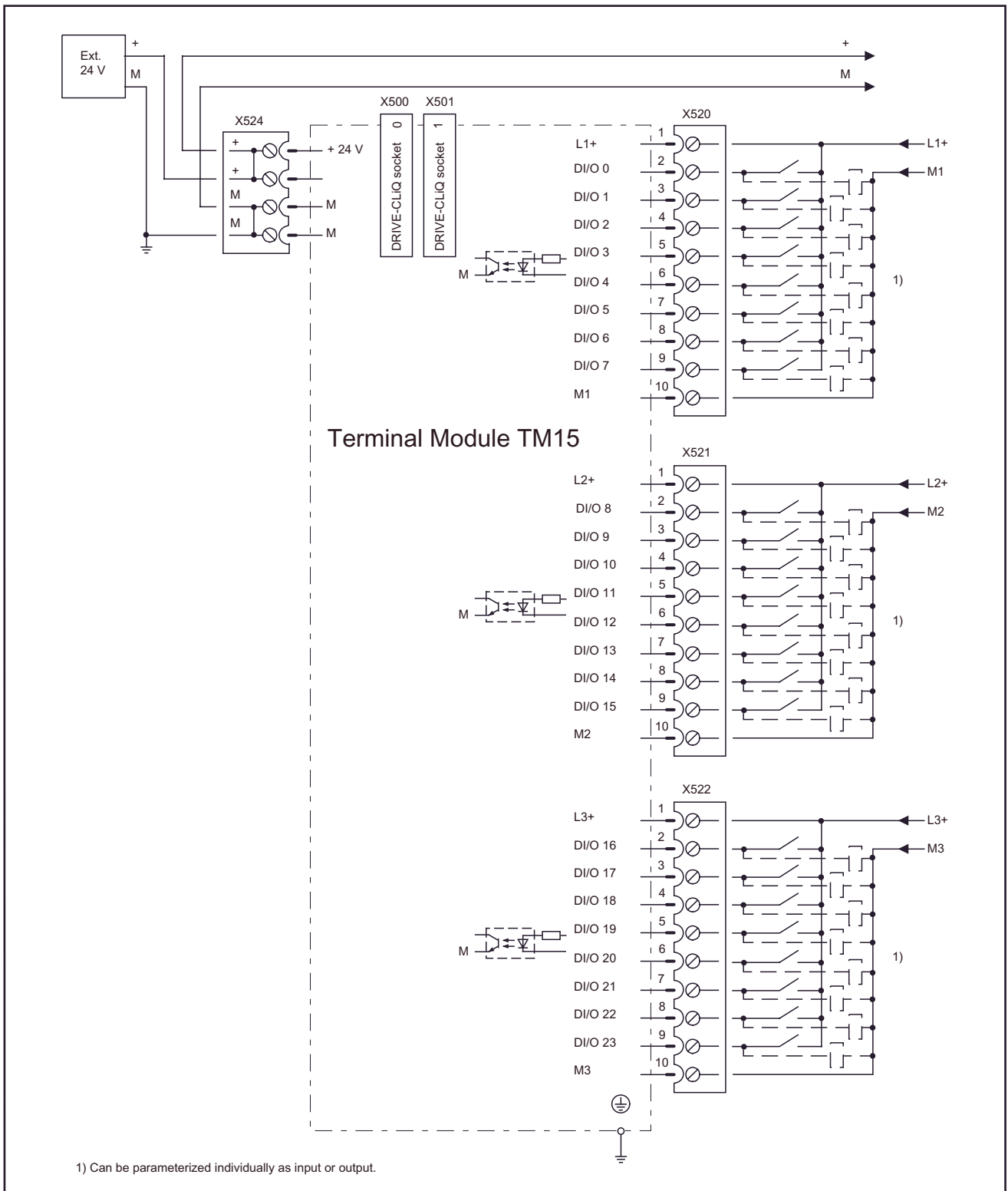
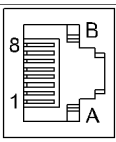

Figure 3-18 Example connection of TM15

3.5.3.3 X500 and X501 DRIVE-CLiQ interface

Table 3- 19 DRIVE-CLiQ interfaces X500 and X501

	Pin	Signal name	Technical specifications
	1	TXP	Transmit data +
	2	TXN	Transmit data -
	3	RXP	Receive data +
	4	Reserved, do not use	
	5	Reserved, do not use	
	6	RXN	Receive data -
	7	Reserved, do not use	
	8	Reserved, do not use	
	A	+ (24 V)	Power supply
	B	M (0 V)	Electronics ground
Blanking plate for DRIVE-CLiQ interfaces included in the scope of delivery; blanking plate (50 pieces) order number: 6SL3066-4CA00-0AA0			

3.5.3.4 X524 Electronics power supply

Table 3- 20 Terminals for the electronics power supply

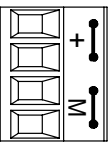
	Terminal	Designation	Technical specifications
	+	Electronics power supply	Voltage: 24 V DC (20.4 V – 28.8 V) Current consumption: max. 0.15 A Max. current via jumper in connector: 20 A
	+	Electronics power supply	
	M	Electronics ground	
	M	Electronics ground	
Max. connectable cross-section: 2.5 mm ² Type: Screw terminal 2 (see Appendix A)			

Note

The two "+" and "M" terminals are jumpered in the connector. This ensures that the supply voltage is looped through.

The current consumption increases by the value for the DRIVE-CLiQ node. The digital outputs are supplied via terminals X520, X521 and X522.

3.5.3.5 X520 digital inputs/outputs

Table 3- 21 Screw terminal X520

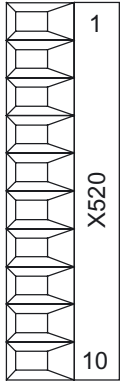
	Terminal	Designation ¹⁾	Technical specifications
	1	L1+	See the section titled "Technical data"
	2	DI/O 0	
	3	DI/O 1	
	4	DI/O 2	
	5	DI/O 3	
	6	DI/O 4	
	7	DI/O 5	
	8	DI/O 6	
	9	DI/O 7	
	10	M1 (GND)	
Max. connectable cross-section: 1.5 mm ² Type: Screw terminal 1 (see Appendix A)			

- 1) L1+: A 24 V DC power supply for DI/O 0 to 7 (first potential group) must always be connected if at least one DI/O of the potential group is used as output.
- M1: A reference ground for DI/O 0 to 7 (first potential group) must always be connected if at least one DI/O of the potential group is used as either input or output.
- DI/O: digital input/output

3.5.3.6 X521 digital inputs/outputs

Table 3- 22 Screw terminal X521

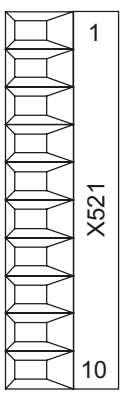
	Terminal	Designation ¹⁾	Technical specifications
	1	L2+	See the section titled "Technical data"
	2	DI/O 8	
	3	DI/O 9	
	4	DI/O 10	
	5	DI/O 11	
	6	DI/O 12	
	7	DI/O 13	
	8	DI/O 14	
	9	DI/O 15	
	10	M2 (GND)	
Max. connectable cross-section: 1.5 mm ² Type: Screw terminal 1 (see Appendix A)			

- 1) L2+: A 24 V DC power supply for DI/O 8 to 15 (second potential group) must always be connected if at least one DI/O of the potential group is used as output.
- M2: A reference ground for DI/O 8 to 15 (second potential group) must always be connected if at least one DI/O of the potential group is used as either input or output.
- DI/O: digital input/output

3.5.3.7 X522 digital inputs/outputs

Table 3- 23 Screw terminal X522

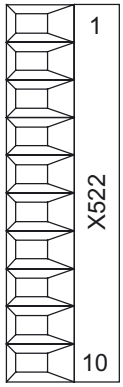
	Terminal	Designation ¹⁾	Technical specifications
	1	L3+	See the section titled "Technical data"
	2	DI/O 16	
	3	DI/O 17	
	4	DI/O 18	
	5	DI/O 19	
	6	DI/O 20	
	7	DI/O 21	
	8	DI/O 22	
	9	DI/O 23	
	10	M3 (GND)	
Max. connectable cross-section: 1.5 mm ² Type: Screw terminal 1 (see Appendix A)			

1) L3+: A 24 V DC infeed for DI/O 16 to 23 (third potential group) must always be connected if at least one DI/O of the potential group is used as an output.

M3: A ground reference for DI/O 16 to 23 (third potential group) must always be connected if at least one DI/O of the potential group is used as either an input or an output.

DI/O: digital input/output

3.5.3.8 Meaning of the LEDs on the Terminal Module TM15

Table 3- 24 Terminal Module TM15 - description of LEDs

LED	Color	Status	Description, cause	Remedy
READY	-	Off	Electronics power supply is missing or outside permissible tolerance range.	-
	Green	Continuous light	The component is ready for operation and cyclic DRIVE-CLiQ communication is taking place.	-
	Orange	Continuous light	DRIVE-CLiQ communication is being established.	-
	Red	Continuous light	At least one fault is present in this component. Note: The LED is activated regardless of whether the corresponding messages have been reconfigured.	Remedy and acknowledge fault
	Green/red	0.5 Hz flashing light	Firmware is being downloaded.	-
		2 Hz flashing light	Firmware download is complete. Wait for POWER ON	Carry out a POWER ON
	Green/orange or Red/orange	Flashing light	Component recognition via LED is activated (p0154). Note: Both options depend on the LED status when component recognition is activated via p0154 = 1.	-

Cause and rectification of faults

The following reference contains information about the cause of faults and how they can be rectified:

/IH1/ SINAMICS S120 Commissioning Manual

/LH1/ SINAMICS S List Manual

3.5.4 Dimension drawing

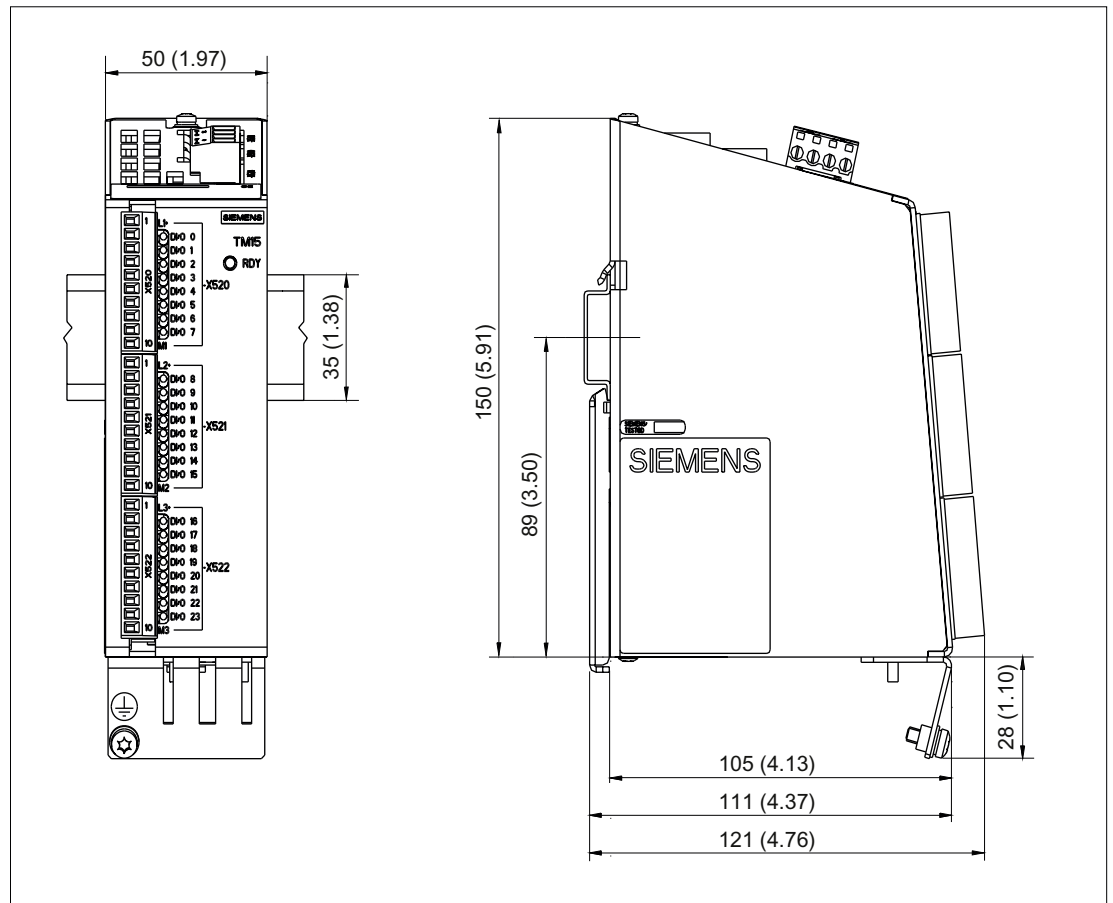

Figure 3-19 Dimension drawing of Terminal Module TM15, all data in mm and (inches)

3.5.5 Installation

Installation

1. Tilt the component backwards slightly and attach it to the DIN rail using the hook.
2. Push the component towards the DIN rail until you hear the mounting slide at the rear latch into position.
3. You can now move the component to the left or right along the DIN rail, until it reaches its final position.

Removal

1. The lug on the mounting slide first needs to be pushed down to unlock the slide from the DIN rail.
2. The component can now be tilted forwards and pulled up and off the DIN rail.

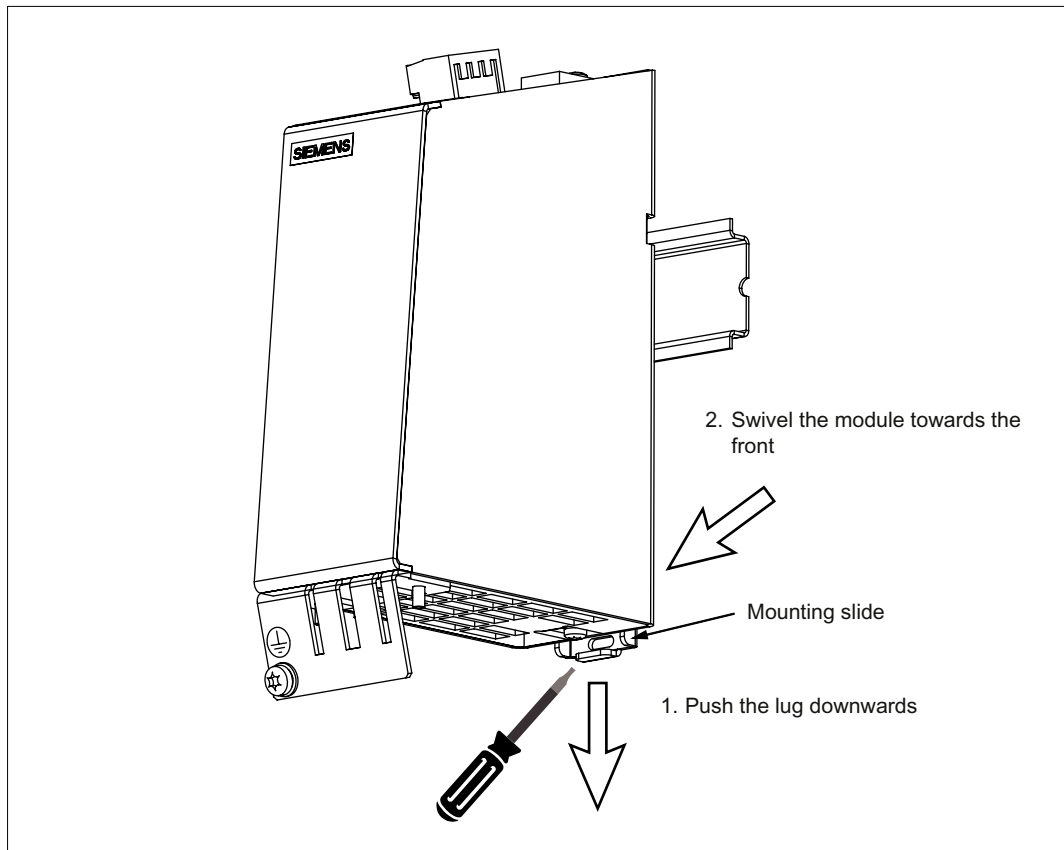

Figure 3-20 Removal of a component from a DIN rail

3.5.6 Protective conductor connection and shield support

It is always advisable to shield the digital I/O wiring.

The following figure shows typical Weidmüller shield connection clamps for the shield supports.

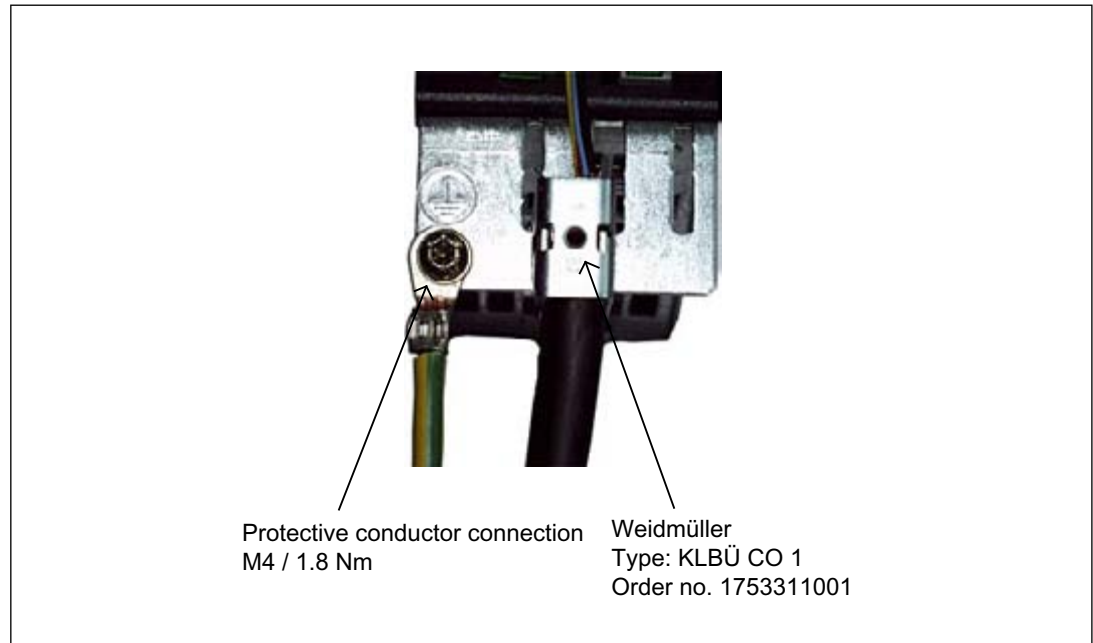

Figure 3-21 Shield supports and protective conductor connection

Weidmüller website address: <http://www.weidmueller.com>

⚠ DANGER
If the shielding procedures described and the specified cable lengths are not observed, the machine may not operate properly.
NOTICE
Only use screws with a permissible mounting depth of 4 - 6 mm.

The TM15 housing is connected to the ground terminal of the module supply (terminal X524). If the ground terminal is actually grounded, then the housing is also grounded. An additional ground connection using the M4 screw is especially necessary if high potential bonding currents can flow (e.g. through the cable shield).

3.5.7 Connector coding

Siemens supplies a series of profiled coding keys ("coding sliders") with each Terminal Module TM15. To encode a connector, you must insert at least one coding slider and cut off a coding lug on the connector:

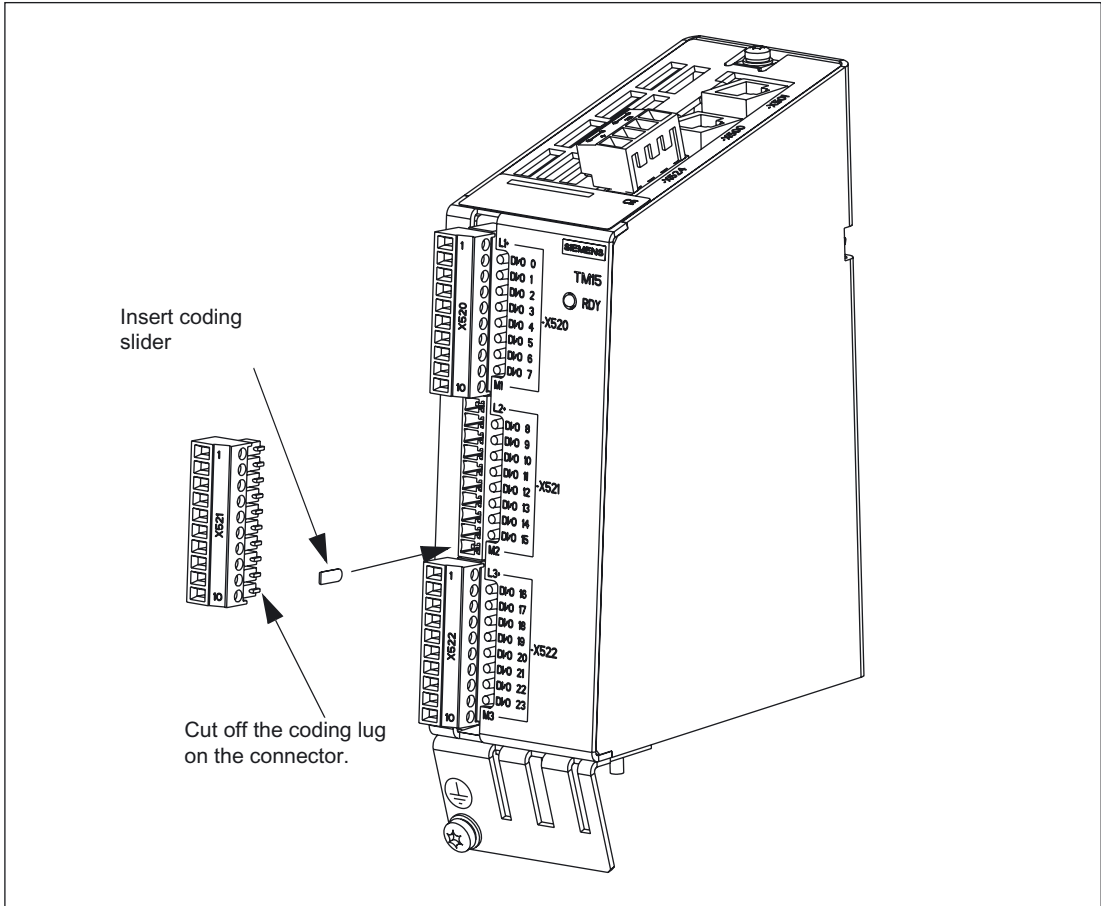

Figure 3-22 Procedure for encoding a connector

To avoid wiring errors, unique coding patterns can be defined for the connectors X520, X521 and X522. Examples of possible patterns:

- 3 connectors on one component are encoded differently (i.e. X520, X521 and X522).
- Different component types are encoded differently.
- Identical components on the same machine are encoded differently (e.g. several TM15-type components).

3.5.8 Technical data

Table 3- 25 Technical data

6SL3055-0AA00-3FAx	Unit	Value
Electronics power supply		
Voltage	V _{DC}	24 DC (20.4 – 28.8)
Current (without DRIVE-CLiQ or digital outputs)	A _{DC}	0.15
Power loss	W	<3
Ambient temperature up to an altitude of 2.000 m	°C	0 - 60
Storage temperature	°C	-40 to +85
Relative humidity	5 % to 95 %, no moisture condensation	
I/O		
Digital inputs/outputs	Can either be parameterized as DI or DO	
Number of digital inputs/outputs	24	
Electrical isolation	Yes, in groups of 8	
Max. cable length	m	30
Digital inputs		
Voltage	V _{DC}	-30 to +30
Low-level (an open digital input is interpreted as "low")	V _{DC}	-30 to +5
High level	V _{DC}	15 to 30
Input Impedance	kΩ	2.8
Current consumption (at 24 V DC)	mA	11
Max. voltage in OFF state	V _{DC}	5
Current in OFF state	mA	0.0 to 1.0 (per channel)
Typical input delay of the digital inputs	μs	L → H: 50 H → L: 100
Digital outputs (continued-short-circuit-proof)		
Voltage	V _{DC}	24
Max. load current per digital output	A _{DC}	0.5
Output delay (ohmic load)		
typical	μs	L → H: 50 H → L: 150
maximum	μs	L → H: 100 H → L: 225
Min. output pulse (100% amplitude, 0.5 A with resistive load)	μs	125 (typ.) 350 (max.)
Switching frequency		
For resistive load	Hz	Max. 100
For inductive load	Hz	Max. 0.5
For lamp load	Hz	Max. 10
Maximum lamp load	W	5
Max. switching frequency (100% amplitude, 50%/50% duty cycle; with 0.5 A and a resistive load)	kHz	1 (typ.)

3.5 Terminal Module TM15

6SL3055-0AA00-3FAx	Unit	Value
Voltage drop in ON state	V _{DC}	0.75 (max.) for maximum load in all circuits
Leakage current in OFF state	μA	max. 10 per channel
Voltage drop, output (I/O power supply to the output)	V _{DC}	0.5
Max. total current of outputs (per group)	A _{DC}	2
up to 60 °C	A _{DC}	3
up to 50 °C	A _{DC}	4
up to 40 °C	A _{DC}	
IEC enclosure specification	IP20 degree of protection	
Protective ground conductor	On housing with M4/1.8 Nm screw	
Response time	<p>The response time for the digital inputs/outputs (TM15 DI/DO) consists of the following elements:</p> <ul style="list-style-type: none"> • Response time on the component itself (approx. 1/2 DRIVE-CLiQ cycle). • Response transmit time via the DRIVE-CLiQ connection (approx. 1 DRIVE-CLiQ cycle). • Evaluation on the Control Unit (see function diagram) <p>References: SINAMICS S List Manual – "Function diagrams" chapter</p>	
Weight	kg	0.86
Approbation	<p>UL and cULus http://www.ul.com File: E164110, Vol. 2, Sec. 9</p>	

3.6 Terminal Module TM17

3.6.1 Description

Information about Terminal Module TM17 is provided in the following literature:

References: Supplementary SINAMICS System Components for SIMOTION

3.7 Terminal Module TM31

3.7.1 Description

The Terminal Module TM31 is a terminal expansion for snapping on to an EN 60715 DIN rail. Terminal Module TM31 can be used to increase the number of available digital inputs/digital outputs and also the number of analog inputs/analog outputs within a drive system.

The TM31 contains the following interfaces:

Table 3- 26 Interface overview of the TM31

Type	Quantity
DRIVE-CLiQ interfaces	2
Digital inputs	8
Digital inputs/outputs	4
Analog inputs	2
Analog outputs	2
Relay outputs	2
Temperature sensor input	1

3.7.2 Safety information

⚠ WARNING

The ventilation spaces of 50 mm above and below the component must be observed.

⚠ CAUTION

Connecting cables to temperature sensors must always be installed with shielding. The cable shield must be connected to the ground potential at both ends over a large surface area. Temperature sensor cables that are routed together with the motor cable must be twisted in pairs and shielded separately.

3.7.3 Interface description

3.7.3.1 Overview

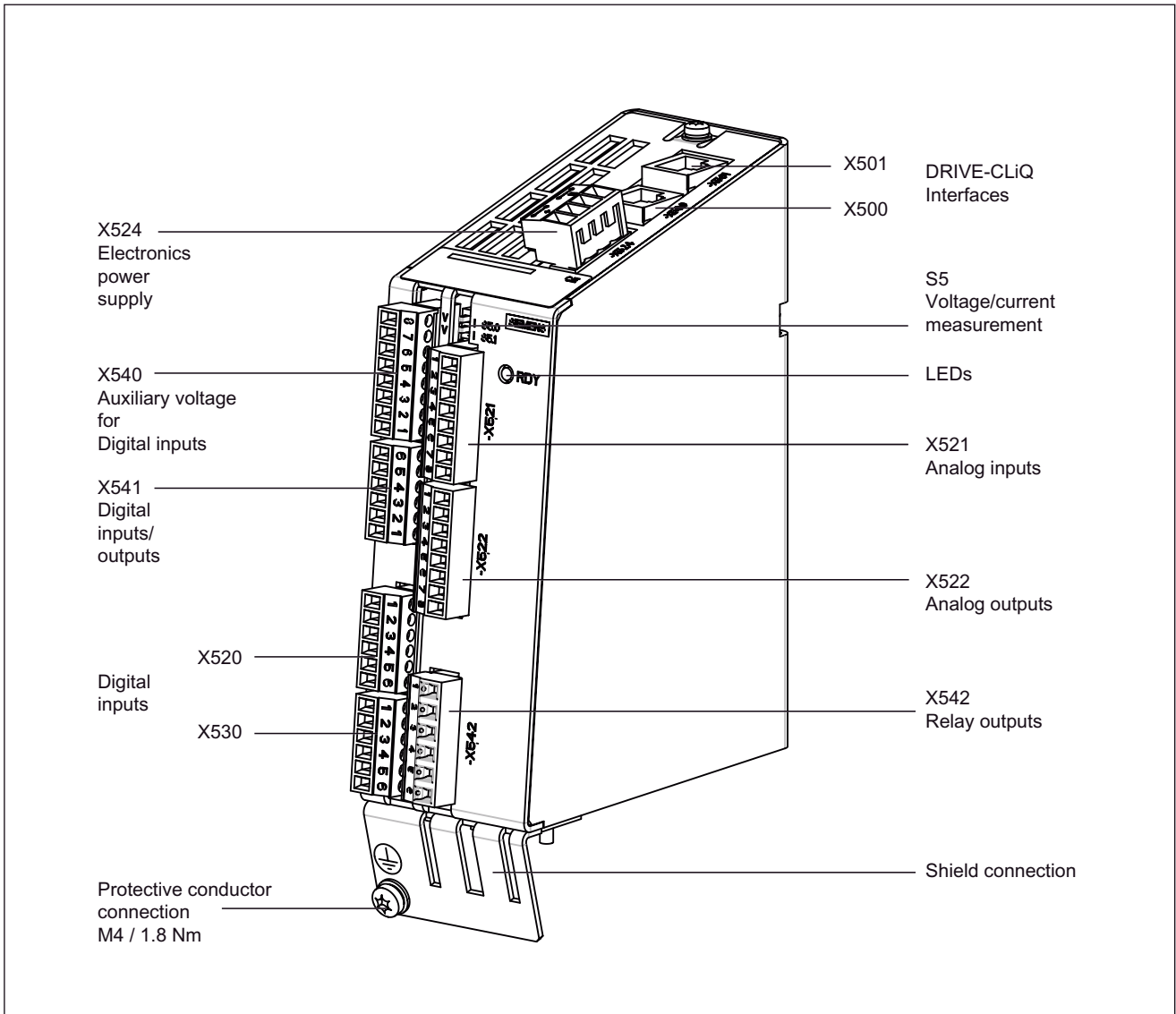

Figure 3-23 Interface description TM31, order number: 6SL3055-0AA00-3AA1

3.7 Terminal Module TM31

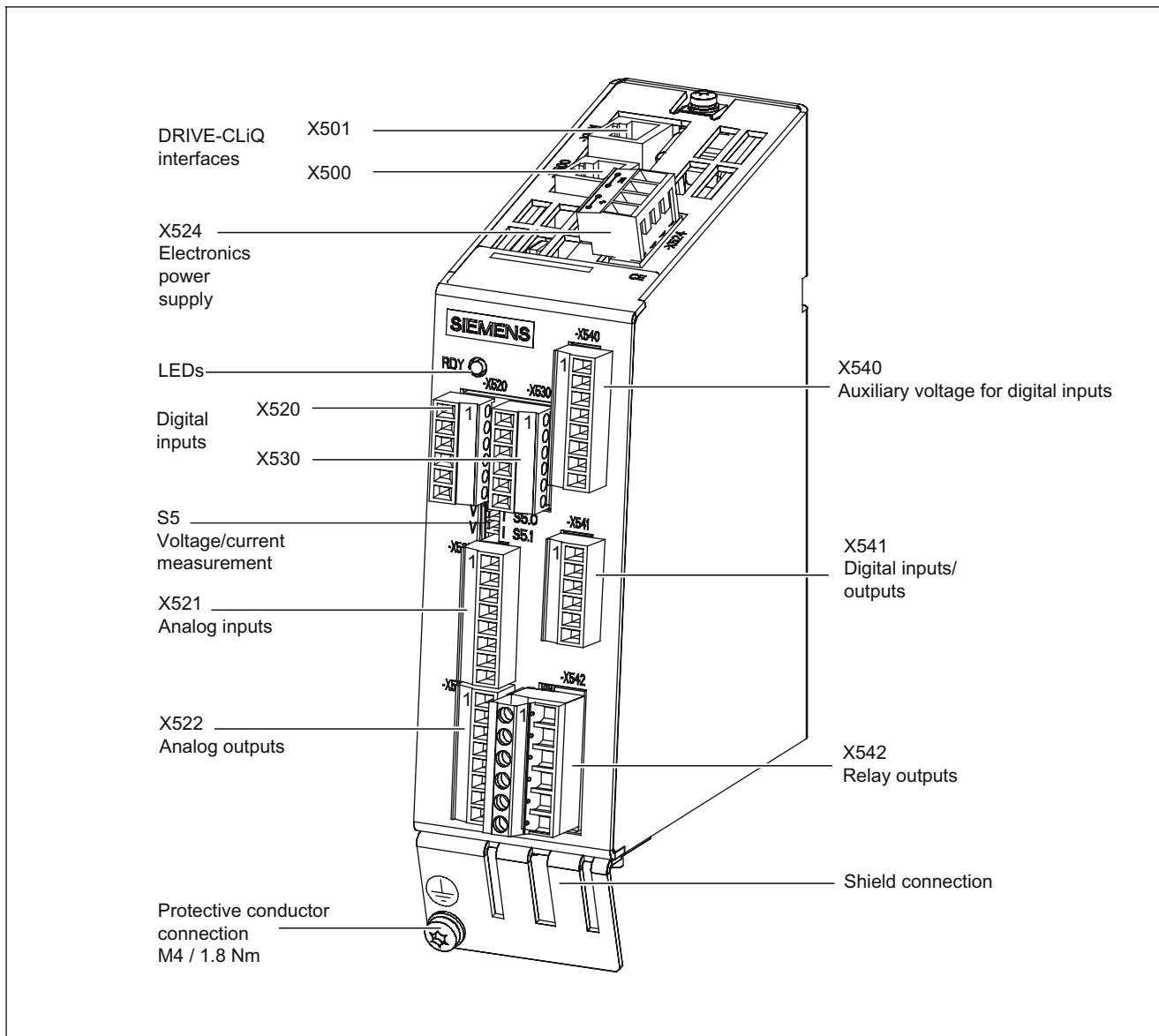

Figure 3-24 Interface description TM31, order number: 6SL3055-0AA00-3AA0

Note

Terminal Module TM31 with order number 6SL3055-0AA00-3AA0 **cannot** be operated with version 4.x drive runtime software.

3.7.3.2 Connection example

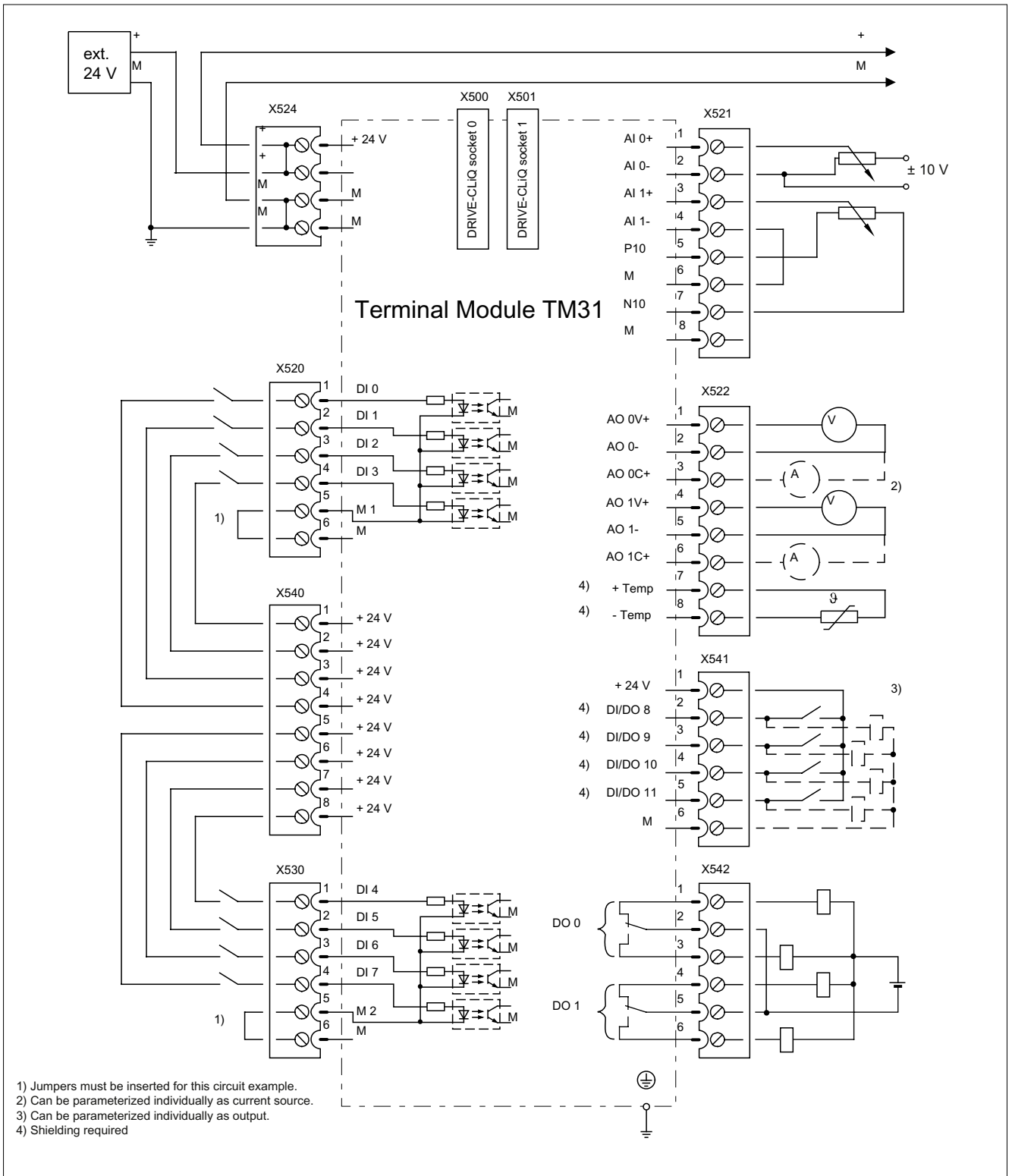
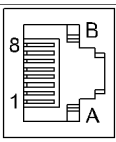

Figure 3-25 Connection example of TM31

3.7.3.3 X500 and X501 DRIVE-CLiQ interface

Table 3- 27 DRIVE-CLiQ interfaces X500 and X501

	Pin	Signal name	Technical specifications
	1	TXP	Transmit data +
	2	TXN	Transmit data -
	3	RXP	Receive data +
	4	Reserved, do not use	
	5	Reserved, do not use	
	6	RXN	Receive data -
	7	Reserved, do not use	
	8	Reserved, do not use	
	A	+ (24 V)	Power supply
	B	M (0 V)	Electronics ground
Blanking plate for DRIVE-CLiQ interfaces included in the scope of delivery; blanking plate (50 pieces) order number: 6SL3066-4CA00-0AA0			

3.7.3.4 X524 Electronics power supply

Table 3- 28 Terminals for the electronics power supply

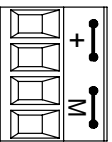
	Terminal	Designation	Technical specifications
	+	Electronics power supply	Voltage: 24 V DC (20.4 V – 28.8 V) Current consumption: max. 0.5 A Max. current via jumper in connector: 20 A
	+	Electronics power supply	
	M	Electronics ground	
	M	Electronics ground	
Max. connectable cross-section: 2.5 mm ² Type: Screw terminal 2 (see Appendix A)			

Note

The two "+" and "M" terminals are jumpered in the connector. This ensures that the supply voltage is looped through.

The current consumption increases by the value for the DRIVE-CLiQ node and digital outputs.

3.7.3.5 Digital inputs X520

Table 3- 29 Screw terminal X520

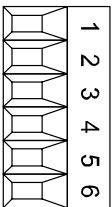
	Terminal	Designation ¹⁾	Technical specifications
	1	DI 0	Voltage: - 3 V to +30 V Typical current consumption: 10 mA at 24 V DC Input delay: - for "0" to "1": Typ. 50 µs max. 100 µs - For "1" to "0": Typ. 130 µs max. 150 µs Electrical isolation: Reference potential is Terminal M1 Level (incl. ripple) High level: 15 V to 30 V Low level: -3 V to +5 V
	2	DI 1	
	3	DI 2	
	4	DI 3	
	5	M1	
	6	M	
Max. connectable cross-section: 1.5 mm ² Type: Screw terminal 1 (see Appendix A)			

1) DI: digital input; M: electronics ground; M1: ground reference

NOTICE

An open input is interpreted as "low".

To enable the digital inputs (DI) to function, terminal M1 must be connected.

This is achieved by:

1. Providing the ground reference of the digital inputs, or
2. A jumper to terminal M (Notice! This removes the electrical isolation for these digital inputs.)

3.7.3.6 Digital inputs X530

Table 3- 30 Screw terminal X530

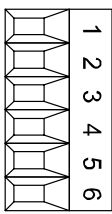
	Terminal	Designation ¹⁾	Technical specifications
	1	DI 4	Voltage: -3 V to +30 V Typical power consumption: 10 mA at 24 V DC Input delay: - for "0" to "1": Typ. 50 µs max. 100 µs - For "1" to "0": Typ. 130 µs max. 150 µs Electrical isolation: Reference potential is Terminal M2 Level (incl. ripple) High level: 15 V to 30 V Low level: -3 V to +5 V
	2	DI 5	
	3	DI 6	
	4	DI 7	
	5	M2	
	6	M	
Max. connectable cross-section: 1.5 mm ² Type: Screw terminal 1 (see Appendix A)			

1) DI: digital input; M: electronics ground; M2: ground reference

NOTICE
An open input is interpreted as "low". To enable the digital inputs (DI) to function, terminal M2 must be connected. This is achieved by: 1. Providing the ground reference of the digital inputs, or 2. A jumper to terminal M (Notice! This removes electrical isolation for these digital inputs).

3.7.3.7 Auxiliary voltage for the digital inputs X540

Table 3- 31 Screw terminal X540, for order number: 6SL3055-0AA00-3AA1

	Terminal	Designation	Technical specifications
	8	+24 V	Voltage: +24 V DC Max. total load current of +24 V auxiliary voltage for terminals X540 and X541 combined: 150 mA
	7	+24 V	
	6	+24 V	
	5	+24 V	
	4	+24 V	
	3	+24 V	
	2	+24 V	
	1	+24 V	
Max. connectable cross-section: 1.5 mm ² Type: Screw terminal 1 (see Appendix A)			

Table 3- 32 Screw terminal X540, for order number: 6SL3055-0AA00-3AA0

	Terminal	Designation	Technical specifications
	1	+24 V	Voltage: +24 V DC Max. total load current of +24 V auxiliary voltage for terminals X540 and X541 combined: 150 mA
	2	+24 V	
	3	+24 V	
	4	+24 V	
	5	+24 V	
	6	+24 V	
	7	+24 V	
	8	+24 V	
Max. connectable cross-section: 1.5 mm ² Type: Screw terminal 1 (see Appendix A)			

Note

This voltage supply is only for powering the digital inputs.

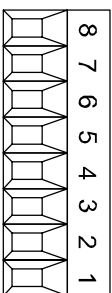
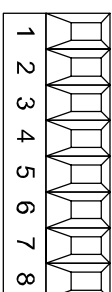
3.7.3.8 X521 analog inputs

Table 3- 33 Terminal block X521

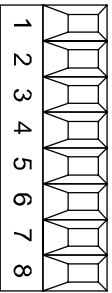
	Terminal	Designation ¹⁾	Technical specifications
	1	AI 0+	The analog inputs can be toggled between current and voltage input using switches S5.0 and S5.1. Voltage: -10 V to +10 V; R _i = 100 kΩ Resolution: 11 bit + sign Current: R _i = 250 Ω Resolution: 10 bits + sign
	2	AI 0-	
	3	AI 1+	
	4	AI 1-	
	5	P10	Auxiliary voltage: P10 = 10 V N10 = -10 V Continued-short-circuit-proof
	6	M	
	7	N10	
	8	M	
Max. connectable cross-section: 1.5 mm ² Type: Screw terminal 1 (see Appendix A)			

1) AI: analog inputs; P10/N10: auxiliary voltage; M or GND: ground reference

CAUTION
If more than ±35 mA flows through the analog current input, then the component could be destroyed. Permissible input voltage ±30 V (destruction limit). Permissible common-mode voltage ±10 V, more errors if exceeded. Permissible back-EMF at the auxiliary voltage outputs ±15 V.

Note

The power supply for the analog inputs can be taken internally or from an external power supply unit

3.7.3.9 S5 current/voltage changeover switch for analog inputs

Table 3- 34 Current/voltage selector S5

	Switch	Function
	S5.0	Selector voltage (V)/current (I) AI0
	S5.1	Selector voltage (V)/current (I) AI1

3.7.3.10 X522 analog outputs/temperature sensor

Table 3- 35 Terminal block X522

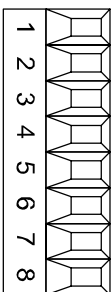
	Terminal	Designation ¹⁾	Technical specifications
	1	AO 0V+	You can set the following output signals using parameters: Voltage: -10 V to 10 V (max. 3 mA)
	2	AO 0-	
	3	AO 0C+	Current 1: 4 mA to 20 mA (max. load resistance ≤ 500 Ω)
	4	AO 1V+	Current 2: -20 mA to 20 mA (max. load resistance ≤ 500 Ω)
	5	AO 1-	Current 3: 0 mA to 20 mA (max. load resistance ≤ 500 Ω)
	6	AO 1C+	Resolution: 11 bits + sign Continued-short-circuit-proof
	7	+ Temp	Temperature sensor KTY84-1C130 / PTC
	8	- Temp	
Max. connectable cross-section: 1.5 mm ² Type: Screw terminal 1 (see Appendix A)			

1) AO xV: analog output voltage; AO xC: analog output current

CAUTION
Permissible back-EMF at the outputs: ±15V

⚠ DANGER
Risk of electric shock!
<p>Only temperature sensors that meet the safety isolation specifications contained in EN 61800-5-1 may be connected to terminals "+Temp" and "-Temp". If safe electrical separation cannot be guaranteed (for linear motors or third-party motors, for example), a Sensor Module External (SME120 or SME125) or Terminal Module TM120 must be used.</p> <p>If these instructions are not complied with, there is a risk of electric shock!</p>

3.7 Terminal Module TM31

3.7.3.11 X541 bidirectional digital inputs/outputs

Table 3- 36 Terminals for bidirectional digital inputs/outputs, for order number 6SL3055-0AA00-3AA1

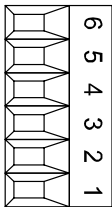
	Terminal	Designation ¹⁾	Technical specifications
	6	M	Auxiliary voltage: Voltage: +24 V DC Max. total load current of +24 V auxiliary voltage of terminals X540 and X541 combined: 150 mA As input: Voltage: -3 V to 30 V Typical current consumption: 10 mA at 24 V DC Input delay: - for "0" to "1": Typ. 50 µs - For "1" to "0": Typ. 100 µs As output: Voltage: 24 V DC Max. load current per output: 500 mA Max. total current of outputs (including currents to the inputs): 100 mA/1 A (can be parameterized) Continued-short-circuit-proof Output delay: - For "0" to "1": Typ. 150 µs at 0.5 A resistive load (500 µs maximum) - For "1" to "0": Typ. 50 µs at 0.5 A resistive load Switching frequency: For resistive load: Max. 100 Hz For inductive load: Max. 0.5 Hz For lamp load: Max. 10 Hz Maximum lamp load: 5 W
	5	DI/DO 11	
	4	DI/DO 10	
	3	DI/DO 9	
	2	DI/DO 8	
	1	+24 V	
Max. connectable cross-section: 1.5 mm ² Type: Screw terminal 1 (see Appendix A)			

1) DI/DO: bidirectional digital input/output; M: Electronics ground

Table 3- 37 Terminals for bidirectional digital inputs/outputs, for order number 6SL3055-0AA00-3AA0

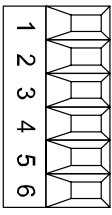
	Terminal	Designation ¹⁾	Technical specifications
	1	+24 V	Auxiliary voltage: Voltage: +24 V DC Max. total load current of +24 V auxiliary voltage of terminals X540 and X541 combined: 150 mA As input: Voltage: -3 V to 30 V Typical current consumption: 10 mA at 24 V DC Input delay: - for "0" to "1": Typ. 50 µs - For "1" to "0": Typ. 100 µs As output: Voltage: 24 V DC Max. load current per output: 500 mA Max. total current of outputs (including currents to the inputs): 100 mA / 1 A (can be parameterized) Sustained short-circuit Output delay: - for "0" to "1": Typically 150 µs at 0.5 A ohmic load (500 µs maximum) - for "1" to "0": Typically 50 µs at 0.5 A ohmic load Switching frequency: For resistive load: Max. 100 Hz For inductive load: Max. 0.5 Hz For lamp load: Max. 10 Hz Maximum lamp load: 5 W
	2	DI/DO 8	
	3	DI/DO 9	
	4	DI/DO 10	
	5	DI/DO 11	
	6	M	
Max. connectable cross-section: 1.5 mm ² Type: Screw terminal 1 (see Appendix A)			

1) DI/DO: bidirectional digital input/output; M: Electronics ground

Note

An open input is interpreted as "low".

Note

If the 24 V supply is briefly interrupted, then the digital outputs are deactivated during this time.

3.7.3.12 Relay outputs X542

Table 3- 38 Terminal block X542, for order number: 6SL3055-0AA00-3AA1

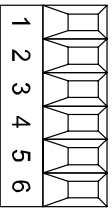
	Terminal	Designation ¹⁾	Technical specifications
	1	DO 0.NC	Contact type: Two-way contact max. load current: 8 A Max. switching voltage: 250 V _{AC} , 30 V _{DC} Max. switching power at 250 V _{AC} : 2.000 VA (cosφ = 1) Max. switching power at 250 V _{AC} : 750 VA (cosφ = 0.4) Max. switching power at 30 V _{DC} : 240 W (resistive load) Required minimum current: 100 mA Overvoltage category: Class III to EN 60664-1
	2	DO 0.COM	
	3	DO 0.NO	
	4	DO 1.NC	
	5	DO 1.COM	
	6	DO 1.NO	
Max. connectable cross-section 2.5 mm ² Type: Screw terminal 3 (see Appendix A)			

1) DO: digital output, NO: normally-open contact, NC: normally-closed contact, COM: mid-position contact

Table 3- 39 Terminal block X542, for order number: 6SL3055-0AA00-3AA0

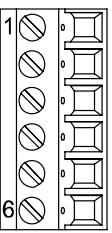
	Terminal	Designation ¹⁾	Technical specifications
	1	DO 0.NC	Contact type: Two-way contact max. load current: 8 A Max. switching voltage: 250 V _{AC} , 30 V _{DC} Max. switching power at 250 V _{AC} : 2.000 VA (cosφ = 1) Max. switching power at 250 V _{AC} : 750 VA (cosφ = 0.4) Max. switching power at 30 V _{DC} : 240 W (resistive load) Required minimum current: 100 mA Overvoltage category: Class III to EN 60664-1
	2	DO 0.COM	
	3	DO 0.NO	
	4	DO 1.NC	
	5	DO 1.COM	
	6	DO 1.NO	
Max. connectable cross-section 2.5 mm ² Type: Screw terminal 3 (see Appendix A)			

1) DO: digital output, NO: normally-open contact, NC: normally-closed contact, COM: mid-position contact

3.7.3.13 Meanings of the LED on the Terminal Module TM31

Table 3- 40 Terminal Module TM31 - description of LEDs

LED	Color	State	Description, cause	Remedy
READY	-	OFF	Electronics power supply is missing or outside permissible tolerance range.	-
	Green	Continuous	The component is ready for operation and cyclic DRIVE-CLiQ communication is taking place.	-
	Orange	Continuous	DRIVE-CLiQ communication is being established.	-
	Red	Continuous	At least one fault is present in this component. Note: The LED is activated regardless of whether the corresponding messages have been reconfigured.	Remedy and acknowledge fault
	Green/red	Flashing 0.5 Hz	Firmware is being downloaded.	-
		Flashing 2 Hz	Firmware download is complete. Wait for POWER ON	Carry out a POWER ON
	Green/orange or Red/orange	Flashing	Component recognition via LED is activated (p0154). Note: Both options depend on the LED status when component recognition is activated via p0154 = 1.	-

Cause and rectification of faults

The following reference contains information about the cause of faults and how they can be rectified:

/IH1/ SINAMICS S120 Commissioning Manual

/LH1/ SINAMICS S List Manual

3.7.4 Dimension drawings

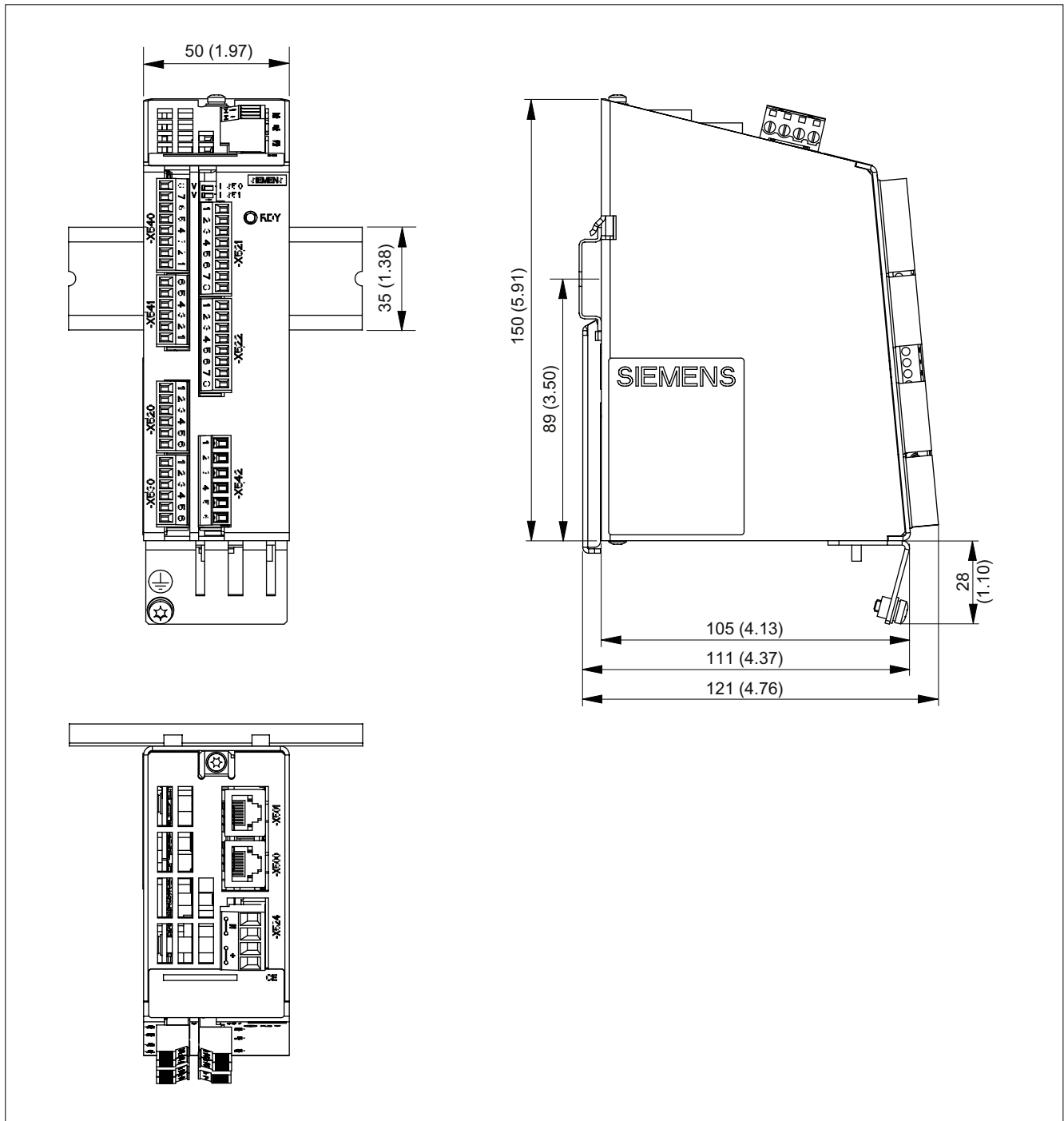

Figure 3-26 Dimension drawing of Terminal Module TM31, all data in mm and (inches), order number: 6SL3055-0AA00-3AA1

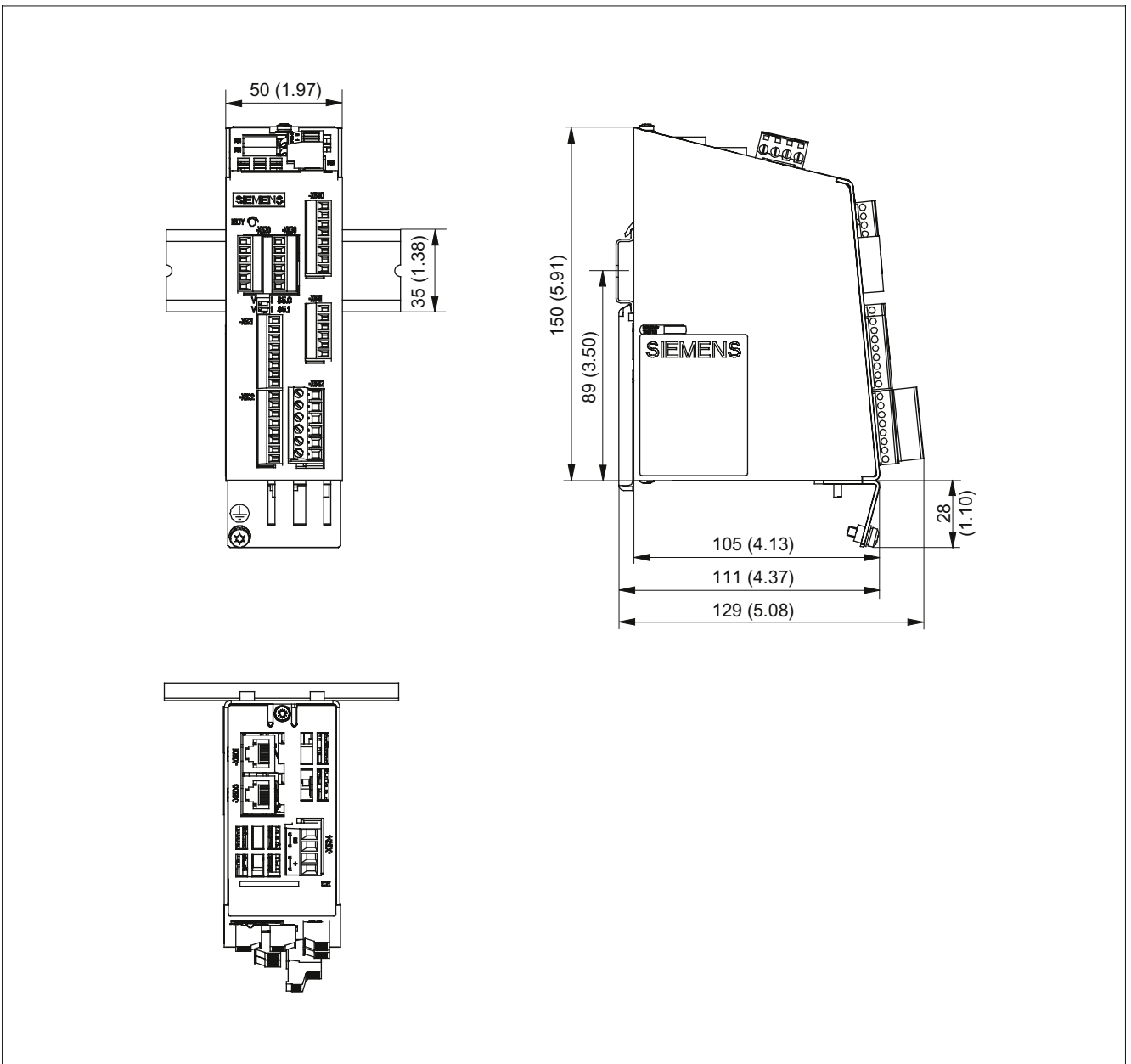

Figure 3-27 Dimension drawing of Terminal Module TM31, all data in mm and (inches), order number: 6SL3055-0AA00-3AA0

3.7.5 Installation

Installation

1. Tilt the component backwards slightly and attach it to the DIN rail using the hook.
2. Push the component towards the DIN rail until you hear the mounting slide at the rear latch into position.
3. You can now move the component to the left or right along the DIN rail, until it reaches its final position.

Removal

1. The lug on the mounting slide first needs to be pushed down to unlock the slide from the DIN rail.
2. The component can now be tilted forwards and pulled up and off the DIN rail.

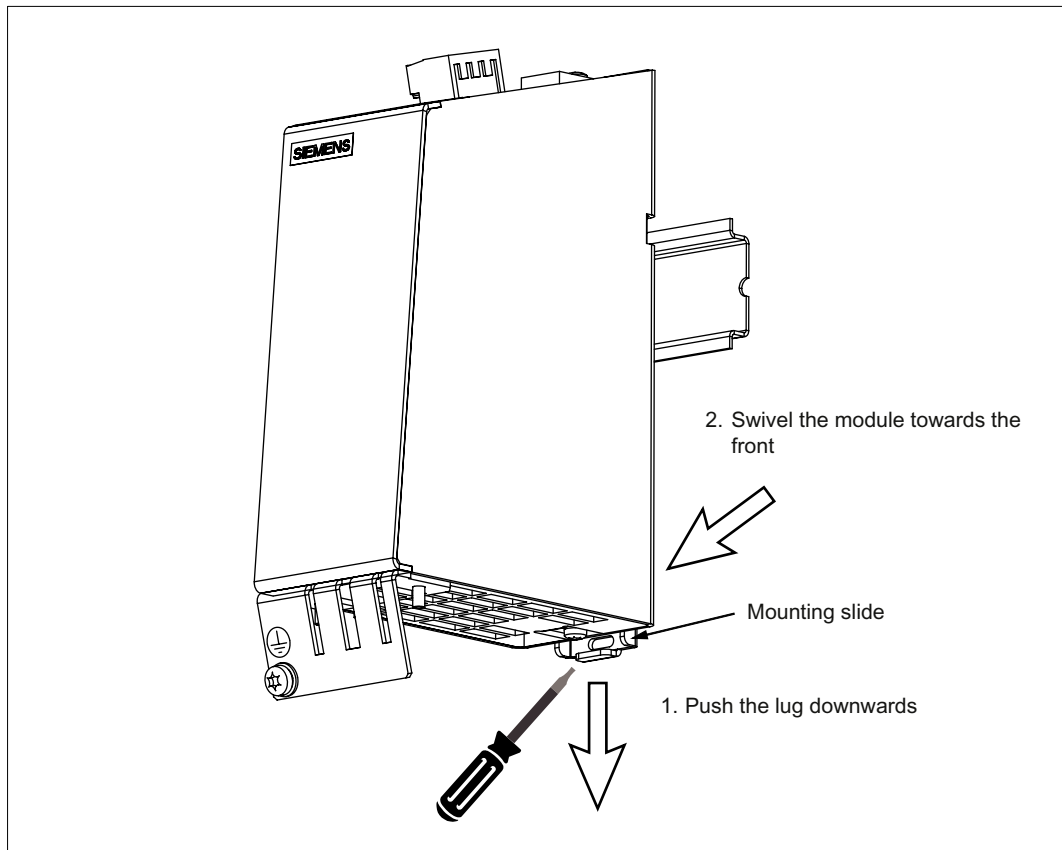

Figure 3-28 Removal of a component from a DIN rail

3.7.6 Protective conductor connection and shield support

It is always advisable to shield the digital I/O wiring.

The following figure shows typical Weidmüller shield connection clamps for the shield supports.

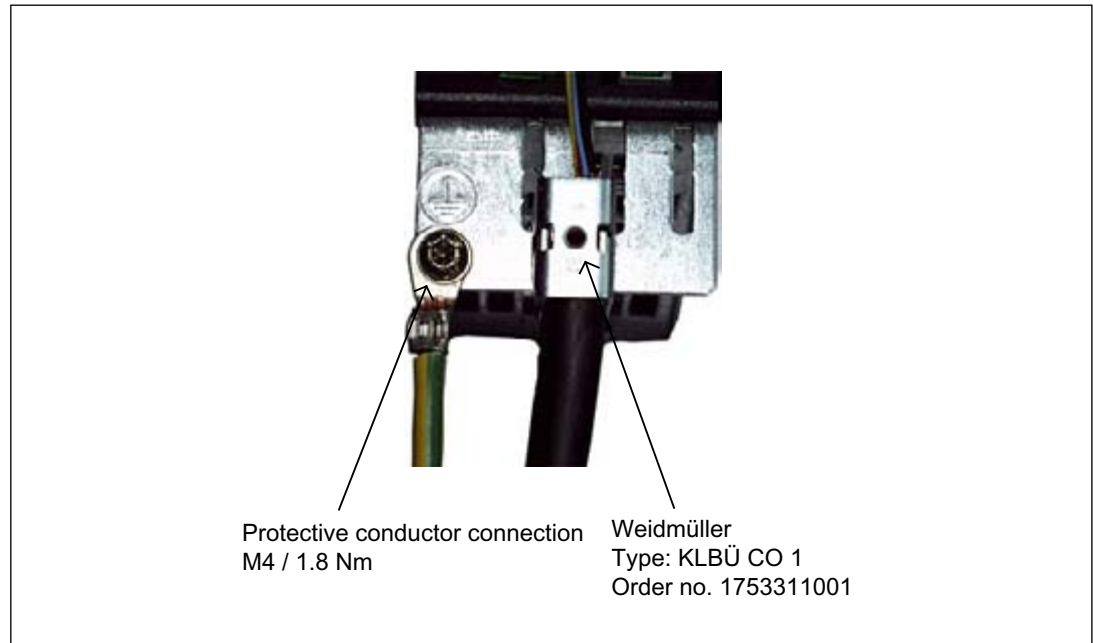

Figure 3-29 Shield supports and protective conductor connection

Weidmüller website address: <http://www.weidmueller.com>

⚠ DANGER
If the shielding procedures described and the specified cable lengths are not observed, the machine may not operate properly.
NOTICE
Only use screws with a permissible mounting depth of 4 - 6 mm.

3.7.7 Connector coding

To ensure that identical connectors are assigned correctly on the TM31, the connectors are encoded as shown in the following diagram.

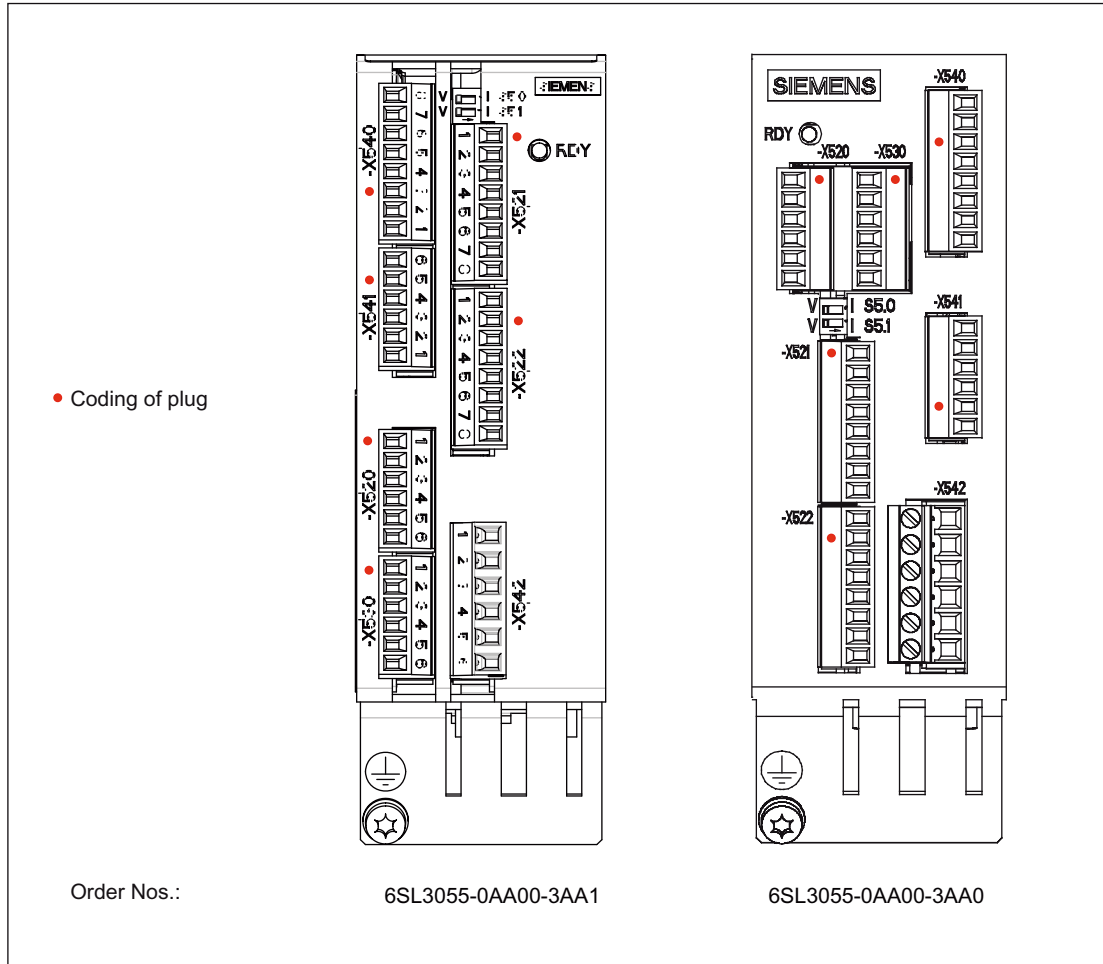

Figure 3-30 Connector codes of the TM31

The bending radii of the cables must be taken into account (see description of MOTION-CONNECT).

3.7.8 Technical data

Table 3- 41 Technical data

6SL3055-0AA00-3AAx	Unit	Value
Electronics power supply		
Voltage	V _{DC}	24 DC (20.4 – 28.8)
Current (without DRIVE-CLiQ or digital outputs)	A _{DC}	0.5
Power loss	W	<10
PE/ground connection	On housing with M4/1.8 Nm screw	
Response time	<p>The response time for the digital inputs/outputs and the analog inputs/outputs consists of the following elements:</p> <ul style="list-style-type: none"> • Response time on the component itself (approx. 1/2 DRIVE-CLiQ cycle). • Response transmit time via the DRIVE-CLiQ connection (approx. 1 DRIVE-CLiQ cycle). • Evaluation on the Control Unit (see function diagram). <p>References:SINAMICS S List Manual – "Function diagrams" chapter</p>	
Weight	kg	1

3.8 Terminal Module TM41

3.8.1 Description

The Terminal Module TM41 is an expansion module for snapping on to a DIN rail (EN 60715) in the control cabinet.

An incremental encoder can be emulated using the encoder interface of the TM41. The TM41 can also be used to connect analog controls to SINAMICS.

The TM41 contains the following interfaces:

Table 3- 42 Interface overview of the TM41

Type	Quantity
Digital inputs, floating	4
Digital inputs/outputs	4
Analog inputs	1
TTL encoder output	1

The TM41 can be used with firmware version 2.4 or higher.

3.8.2 Safety information

 **WARNING**

The ventilation spaces of 50 mm above and below the component must be observed.

3.8.3 Interface description

3.8.3.1 Overview

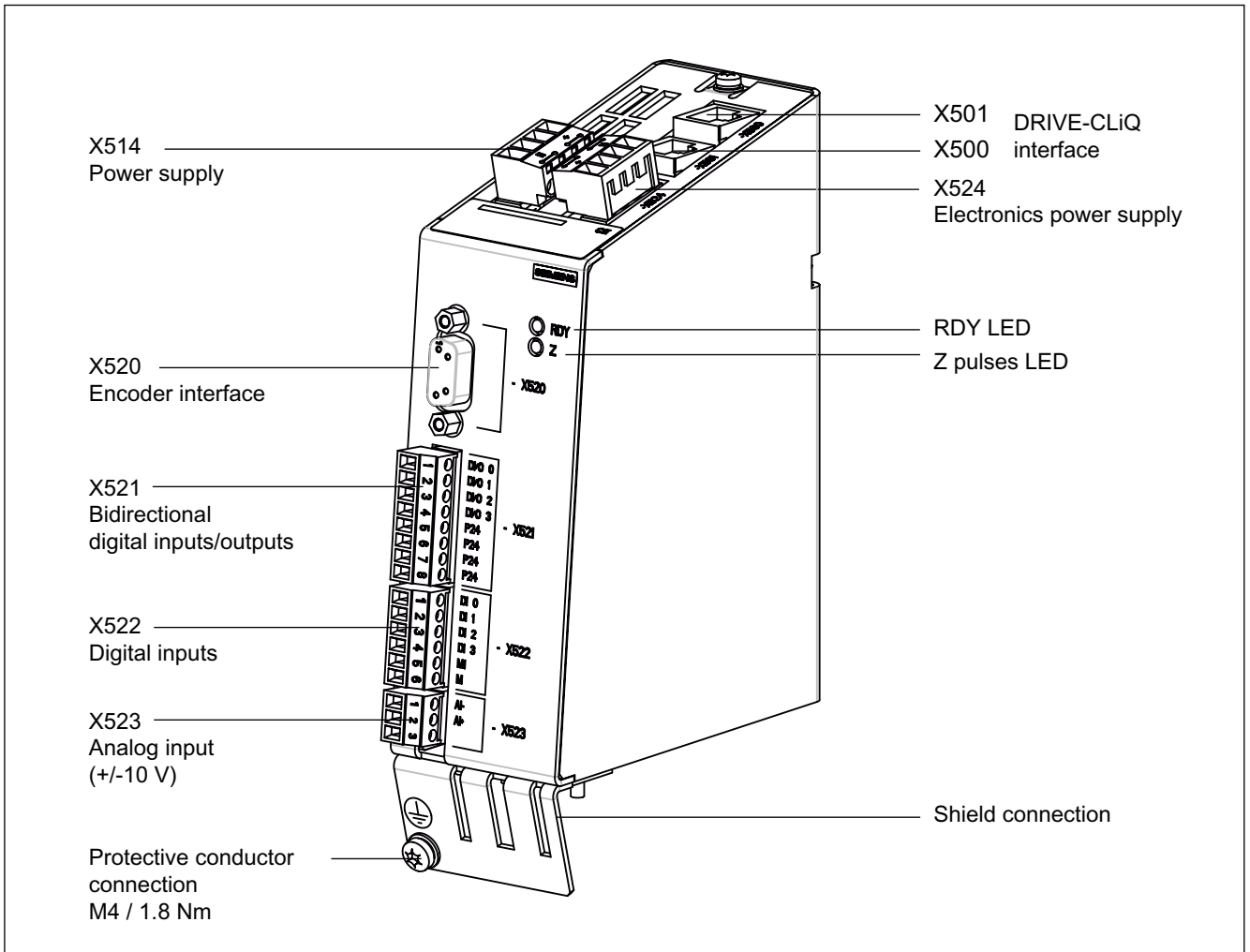

Figure 3-31 TM41 interface description, Order number 6SL3055-0AA00-3PA1

3.8 Terminal Module TM41

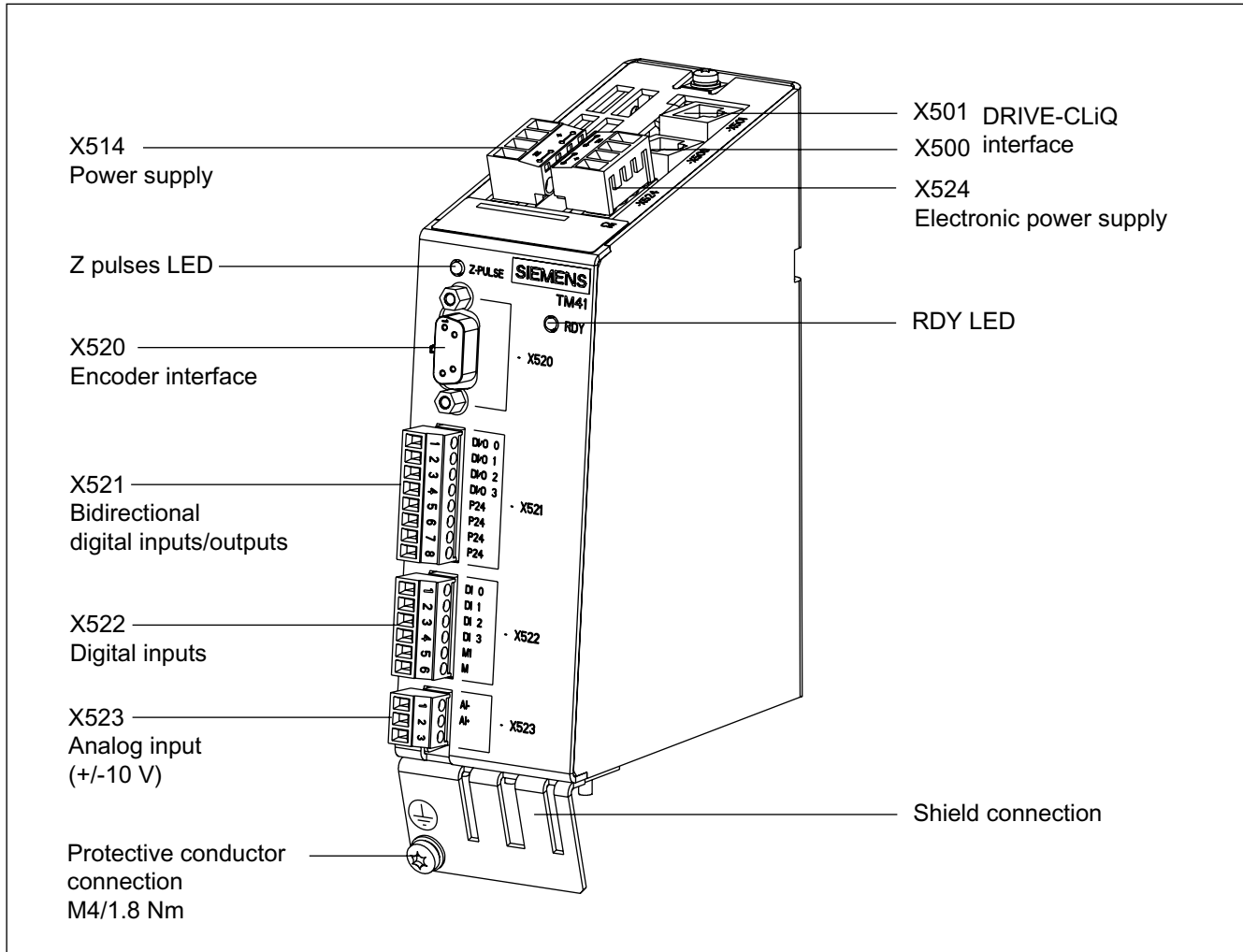

Figure 3-32 TM41 interface description, Order number 6SL3055-0AA00-3PA0

Note

Terminal Module TM41 with order number 6SL3055-0AA00-3PA0 **cannot** be operated with version 4.x drive runtime software.

3.8.3.2 Connection example

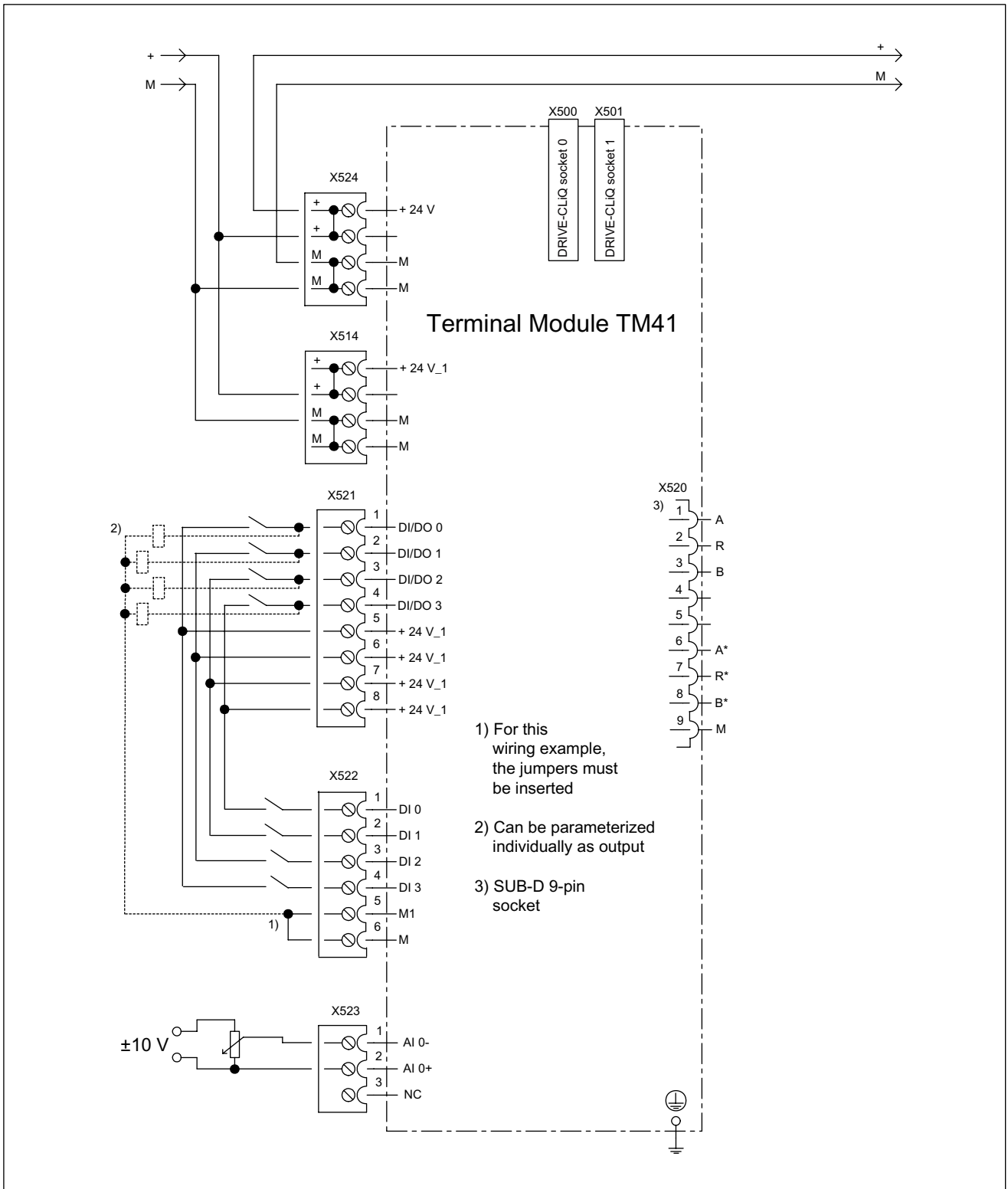
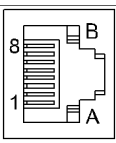

Figure 3-33 Sample connection of TM41

3.8.3.3 X500 and X501 DRIVE-CLiQ interface

Table 3- 43 DRIVE-CLiQ interfaces X500 and X501

	Pin	Signal name	Technical specifications
	1	TXP	Transmit data +
	2	TXN	Transmit data -
	3	RXP	Receive data +
	4	Reserved, do not use	
	5	Reserved, do not use	
	6	RXN	Receive data -
	7	Reserved, do not use	
	8	Reserved, do not use	
	A	+ (24 V)	Power supply
	B	M (0 V)	Electronics ground
Blanking plate for DRIVE-CLiQ interfaces included in the scope of delivery; blanking plate (50 pieces) order number: 6SL3066-4CA00-0AA0			

3.8.3.4 X514 and X524 Power supply

The X514 interface supplies the X521 interface with current.
The X524 interface provides the electronics power supply.

Table 3- 44 Power supply terminals X514 and X524

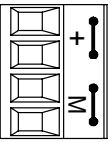
	Terminal	Designation	Technical specifications
	+	Power supply	Voltage: 24 V DC (20.4 V – 28.8 V) Current consumption: max. 0.5 A
	+	Power supply	
	M	Electronics ground	Max. current via jumper in connector: 20 A
	M	Electronics ground	
Max. connectable cross-section: 2.5 mm ² Type: Screw terminal 2 (see Appendix A)			

Note

The two "+" and "M" terminals are jumpered in the connector. This ensures that the supply voltage is looped through.

The current drain of X524 increases by the value for the DRIVE-CLiQ node.

The current drain of X514 increases by the value for the digital outputs.

3.8.3.5 Sensor interface X520

Table 3- 45 X520 interface

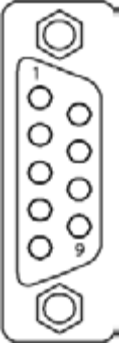
	Pin	Signal name	Technical specifications
	1	A	Incremental signal A
	2	R	Reference signal R
	3	B	Incremental signal B
	4	Reserved, do not use	
	5	Reserved, do not use	
	6	A*	Inverted incremental signal A
	7	R*	Inverted reference signal R
	8	B*	Inverted incremental signal B
	9	M	Ground
TTL encoder 100 m max. cable length Type: 9-pin SUB-D female			

3.8.3.6 X521 Bidirectional digital inputs/outputs

Table 3- 46 Screw terminal X521

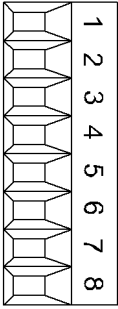
	Terminal	Designation	Technical specifications
	1	DI/DO 0	As input: Voltage: -3 V to 30 V Typical current consumption: 10 mA at 24 V DC Level (including ripple) High level: 15 V to 30 V Low level: -3 V to 5 V Input delay: - for "0" to "1": Typ. 50 µs max. 100 µs - For "1" to "0": typ. 50 µs, max. 100 µs As output: Voltage: 24 V DC Max. load current per output: 0.5 mA Max. total current of outputs: 2 A Continued-short-circuit-proof Output delay: - for "0" to "1": Typ. 150 µs at 0.5 A resistive load (500 µs maximum) - For "1" to "0": Typ. 150 µs at 0.5 A resistive load Switching frequency: For resistive load: Max. 100 Hz For inductive load: Max. 0.5 Hz For lamp load: Max. 10 Hz Maximum lamp load: 5 W
	2	DI/DO 1	
	3	DI/DO 2	
	4	DI/DO 3	
	5	+24 V	Voltage: +24 V DC Max. load current per terminal: 500 mA
	6	+24 V	
	7	+24 V	
	8	+24 V	
Max. connectable cross-section: 1.5 mm ² Type: Screw terminal 1 (see Appendix A)			

Note

This voltage supply is only for powering the digital inputs.

Note

An open input is interpreted as "low".

Note

If a momentary interruption in the voltage occurs in the 24 V supply, the digital outputs will be deactivated until the interruption has been rectified.

3.8.3.7 X522 digital inputs / floating (isolated)

Table 3- 47 Screw terminal X522

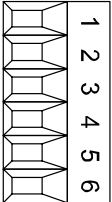
	Terminal	Designation ¹⁾	Technical specifications
	1	DI 0	Voltage: - 3 V to +30 V Typical current consumption: 6.5 mA at 24 V DC Input delay: - for "0" to "1": Typ. 50 µs max. 100 µs - For "1" to "0": typ. 110 µs max. 150 µs electrical isolation: Reference potential is Terminal M1 Level (incl. ripple) High level: 15 V to 30 V Low level: -3 V to +5 V
	2	DI 1	
	3	DI 2	
	4	DI 3	
	5	M1	
	6	M	
Max. connectable cross-section: 1.5 mm ² Type: Screw terminal 1 (see Appendix A)			

1) DI: digital input; M: electronics ground; M1: ground reference

NOTICE

To enable the digital inputs to function, terminal M1 must be connected.

This is achieved by:

1. Providing the ground reference of the digital inputs, or
2. A jumper to terminal M (Notice! This removes electrical isolation for these digital inputs).

3.8.3.8 X523 Analog input

Table 3- 48 Terminal block X523

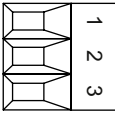
	Terminal	Designation ¹⁾	Technical specifications
	1	AI 0-	Voltage: -10 V to 10 V; R _i = 40 kΩ for component -3PA1 R _i = 100 kΩ Resolution: 14 bits (13 bits + sign) ²⁾ Resolution: 13 bits (12 bits + sign) ³⁾
	2	AI 0+	
	3	Reserved, do not use	
Max. connectable cross-section: 1.5 mm ² Type: Screw terminal 1 (see Appendix A)			

1) AI: analog input

2) Component order numbers that end with -3PA0

3) Component order numbers that end with -3PA1

CAUTION
The Common Mode range may not be violated. Permissible input voltage ±30 V (destruction limit). Permissible Common Mode voltage ±10 V, increased faults if exceeded. If the range is infringed, incorrect results may occur during analog/digital conversion

3.8.3.9 Meaning of the LEDs on the Terminal Module TM41

Table 3- 49 Terminal Module TM41 - description of LEDs

LED	Color	Status	Description, cause	Remedy
READY	-	Off	Electronics power supply is missing or outside permissible tolerance range.	-
	Green	Continuous light	The component is ready for operation and cyclic DRIVE-CLiQ communication is taking place.	-
	Orange	Continuous light	DRIVE-CLiQ communication is being established.	-
	Red	Continuous light	At least one fault is present in this component. Note: The LED is activated regardless of whether the corresponding messages have been reconfigured.	Remedy and acknowledge fault
	Green/red	0.5 Hz flashing light	Firmware is being downloaded.	-
		2 Hz flashing light	Firmware download is complete. Wait for POWER ON.	Carry out a POWER ON
	Green/orange or Red/orange	Flashing light	Component recognition via LED is activated (p0154). Note: Both options depend on the LED status when component recognition is activated via p0154 = 1.	-
Z pulses	-	Off	Zero marker found; wait for zero marker output; OR component switched off.	-
	Red	Continuous light	Zero mark not enabled or zero mark search.	-
	Green	Continuous light	Stopped at zero mark.	-
		Flashing light	Zero mark is output at each virtual revolution.	-

Cause and rectification of faults

The following reference contains information about the cause of faults and how they can be rectified:

/IH1/ SINAMICS S120 Commissioning Manual

/LH1/ SINAMICS S List Manual

3.8.4 Dimension drawings

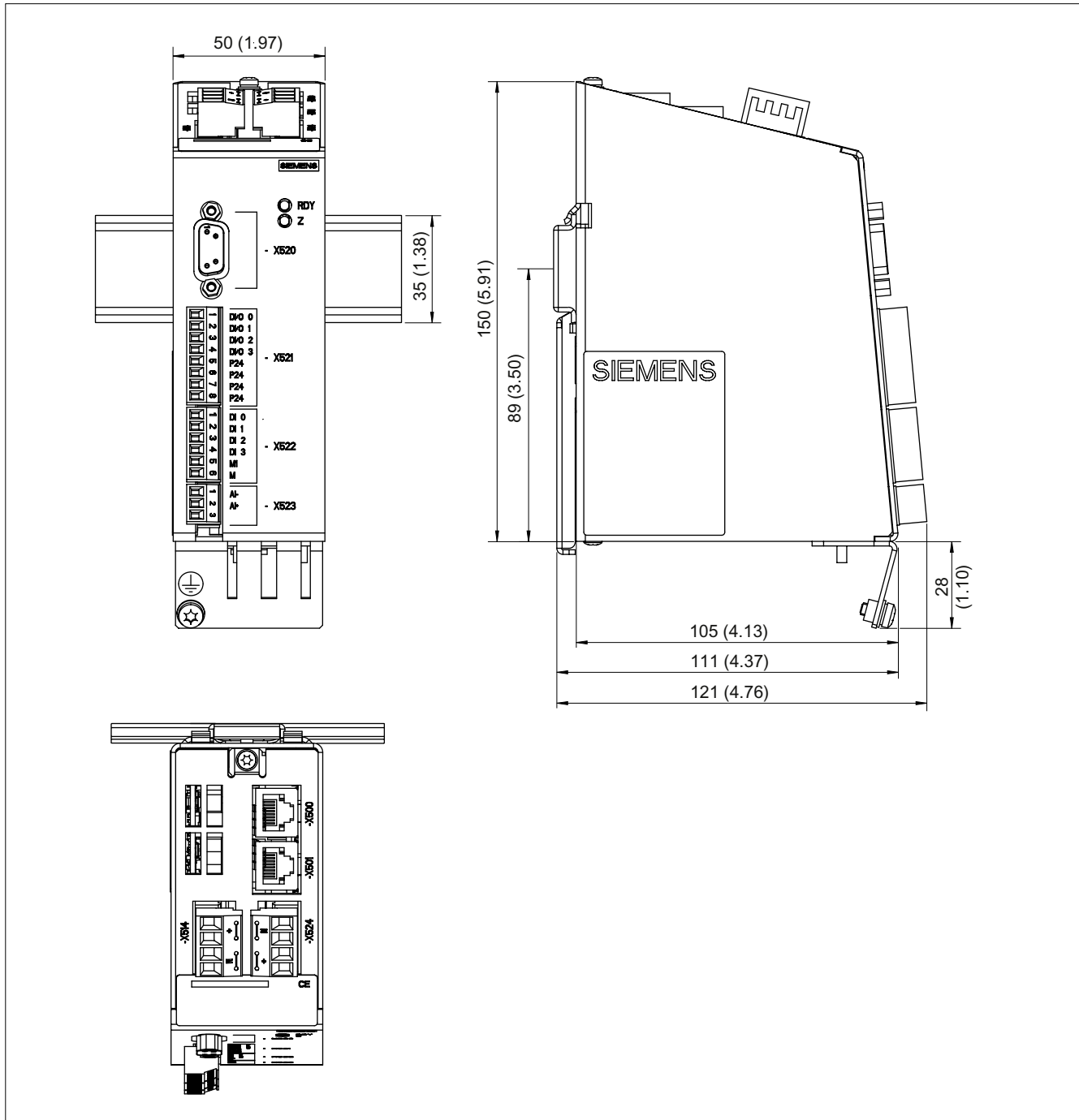

Figure 3-34 Dimension drawing of Terminal Module TM41, all data in mm and (inches), order number 6SL3055-0AA00-3PA1

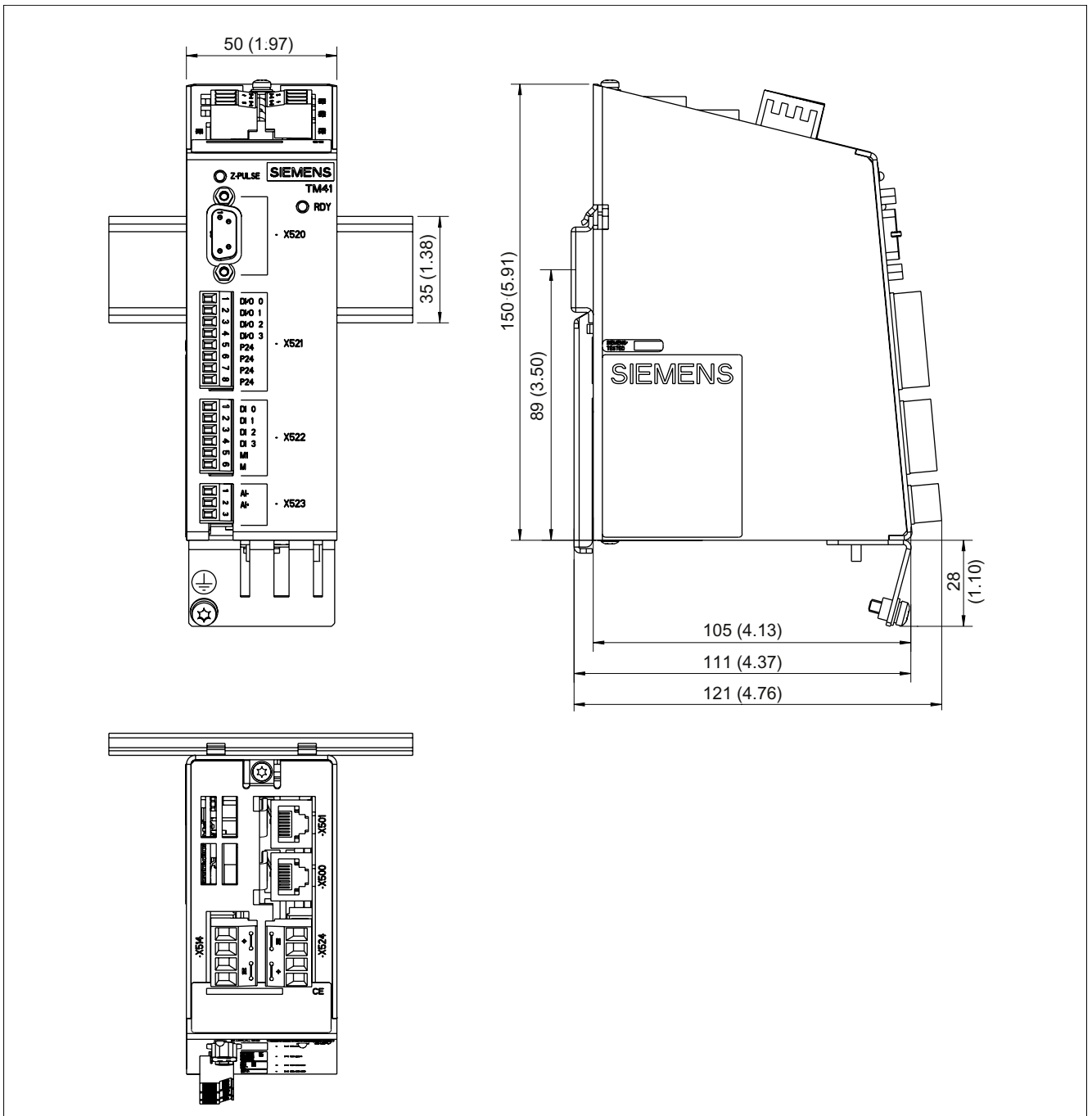

Figure 3-35 Dimension drawing of Terminal Module TM41, all data in mm and (inches), order number 6SL3055-0AA00-3PA0

3.8.5 Installation

Installation

1. Tilt the component backwards slightly and attach it to the DIN rail using the hook.
2. Push the component towards the DIN rail until you hear the mounting slide at the rear latch into position.
3. You can now move the component to the left or right along the DIN rail, until it reaches its final position.

Removal

1. The lug on the mounting slide first needs to be pushed down to unlock the slide from the DIN rail.
2. The component can now be tilted forwards and pulled up and off the DIN rail.

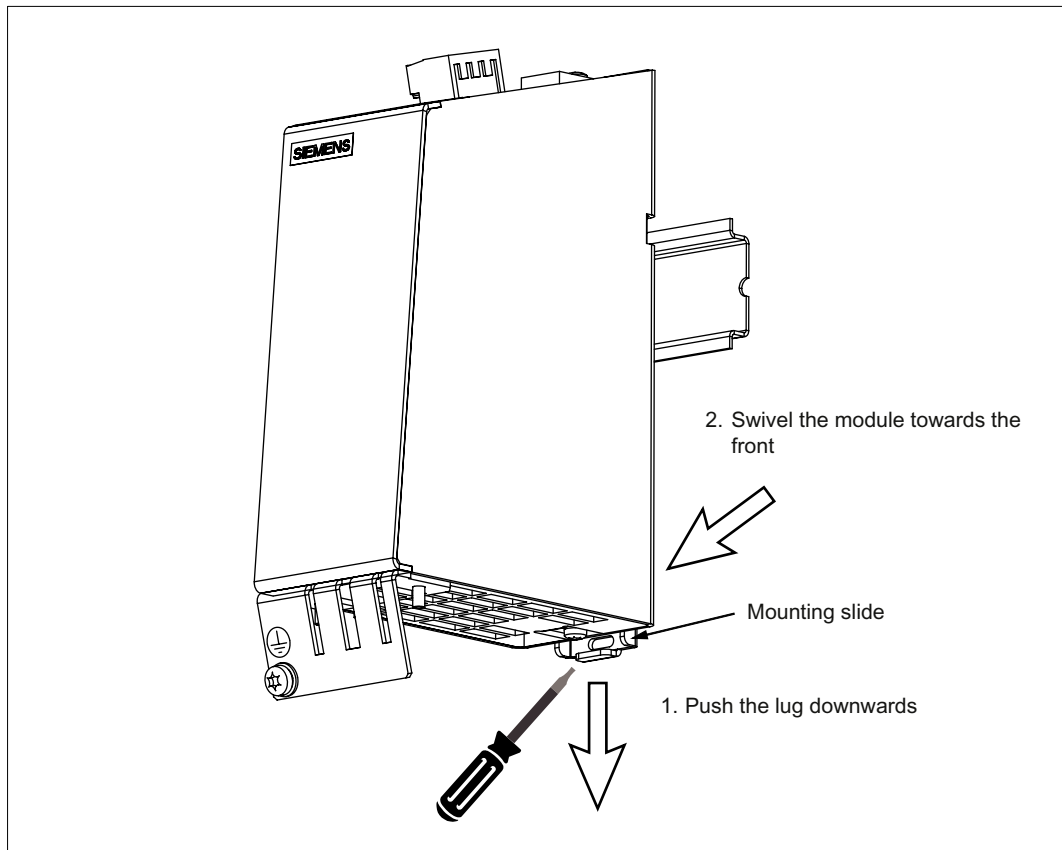

Figure 3-36 Removal of a component from a DIN rail

3.8.6 Protective conductor connection and shield support

It is always advisable to shield the digital I/O wiring.

The following figure shows typical Weidmüller shield connection clamps for the shield supports.

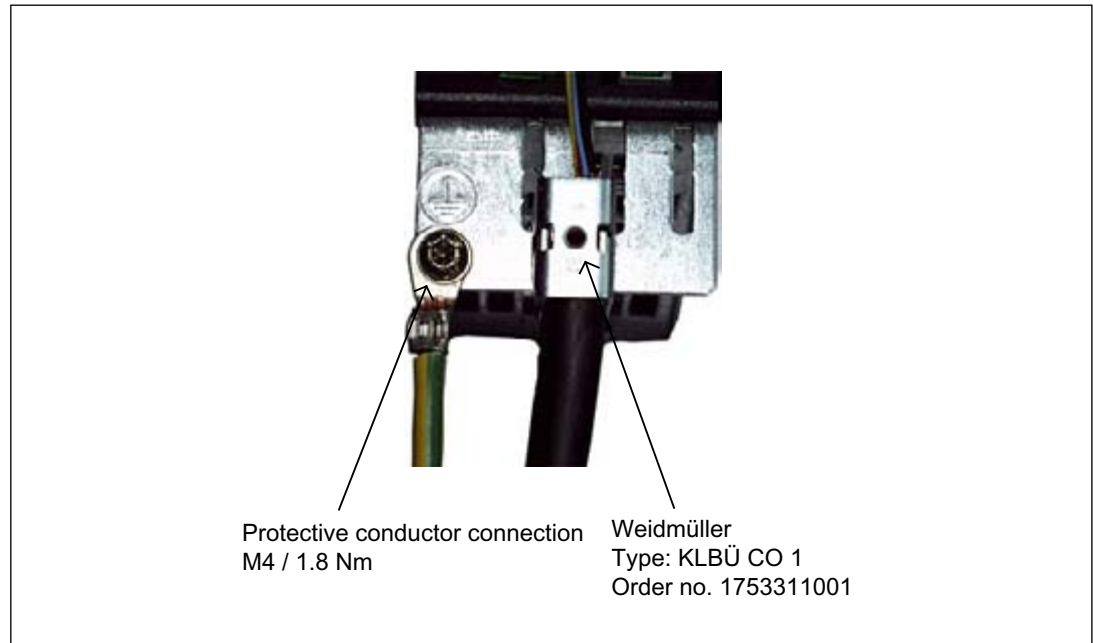

Figure 3-37 Shield supports and protective conductor connection

Weidmüller website address: <http://www.weidmueller.com>

The bending radii of the cables must be taken into account (see description of MOTION-CONNECT).

⚠ DANGER
If the shielding procedures described and the specified cable lengths are not observed, the machine may not operate properly.

NOTICE
Only use screws with a permissible mounting depth of 4 - 6 mm.

3.8.7 Technical data

Table 3- 50 Technical data

6SL3055-0AA00-3PAx	Unit	Value
Electronics power supply		
Voltage	V _{DC}	24 DC (20.4 – 28.8)
Current (without DRIVE-CLiQ or digital outputs)	A _{DC}	0.5
PE/ground connection	On housing with M4/1.8 Nm screw	
Response time	<p>The response time for the digital inputs/outputs and the analog input consists of the following elements:</p> <ul style="list-style-type: none"> • Response time on the component itself (approx. 1/2 DRIVE-CLiQ cycle). • Response transmit time via the DRIVE-CLiQ connection (approx. 1 DRIVE-CLiQ cycle). • Evaluation on the Control Unit (see function diagram). <p>References: SINAMICS S List Manual – "Function diagrams" chapter</p>	
Weight	kg	0.85

3.9 Terminal Module TM54F

3.9.1 Description

The Terminal Module TM54F is a terminal expansion for snapping on to an EN 60715 DIN rail. The TM54F offers safe digital inputs and outputs for controlling SINAMICS Safety Integrated functions. It can be used with firmware version 2.5 + SP1 or higher.

The TM54F must be directly connected to a Control Unit via DRIVE-CLiQ. Motor Modules or Line Modules must not be connected to a TM54F.

Precisely one TM54F can be assigned to each Control Unit.

TM54F features the following interfaces:

Table 3- 51 Interface overview of the TM54F

Type	Quantity
Fail-safe digital outputs (F-DO)	4
Fail-safe digital inputs (F-DI)	10
Sensor ¹⁾ power supplies, dynamization supported ²⁾	2
Sensor ¹⁾ power supply, no dynamization	1
Digital inputs to check F_DO for a test stop	4

1) Sensors: Fail-safe devices to issue commands and sense - for example, emergency stop pushbuttons and safety locks, position switches and light arrays/light curtains.

2) Dynamization: The sensor power supply is cycled on and off by the TM54F when the forced checking procedure is active for the sensors, cable routing, and the evaluation electronics.

The TM54F has 4 fail-safe digital outputs and 10 fail-safe digital inputs. A fail-safe digital output consists of a 24 V DC switching output, a ground switching output, and a digital input for checking the switching state. A fail-safe digital input comprises two digital inputs.

Note

The rated values of the F-DO meet the requirements of EN 61131-2 for digital DC outputs with 0.5 A rated current.

The operating ranges of the F-DI meet the requirements of EN 61131-2 for Type 1 digital inputs.

Note

Please note that the F-DIs must take the form of shielded cables if they are > 30 m in length.

3.9.2 Safety information

 WARNING

The ventilation spaces of 50 mm above and below the component must be observed.

3.9.3 Interface description

3.9.3.1 Overview

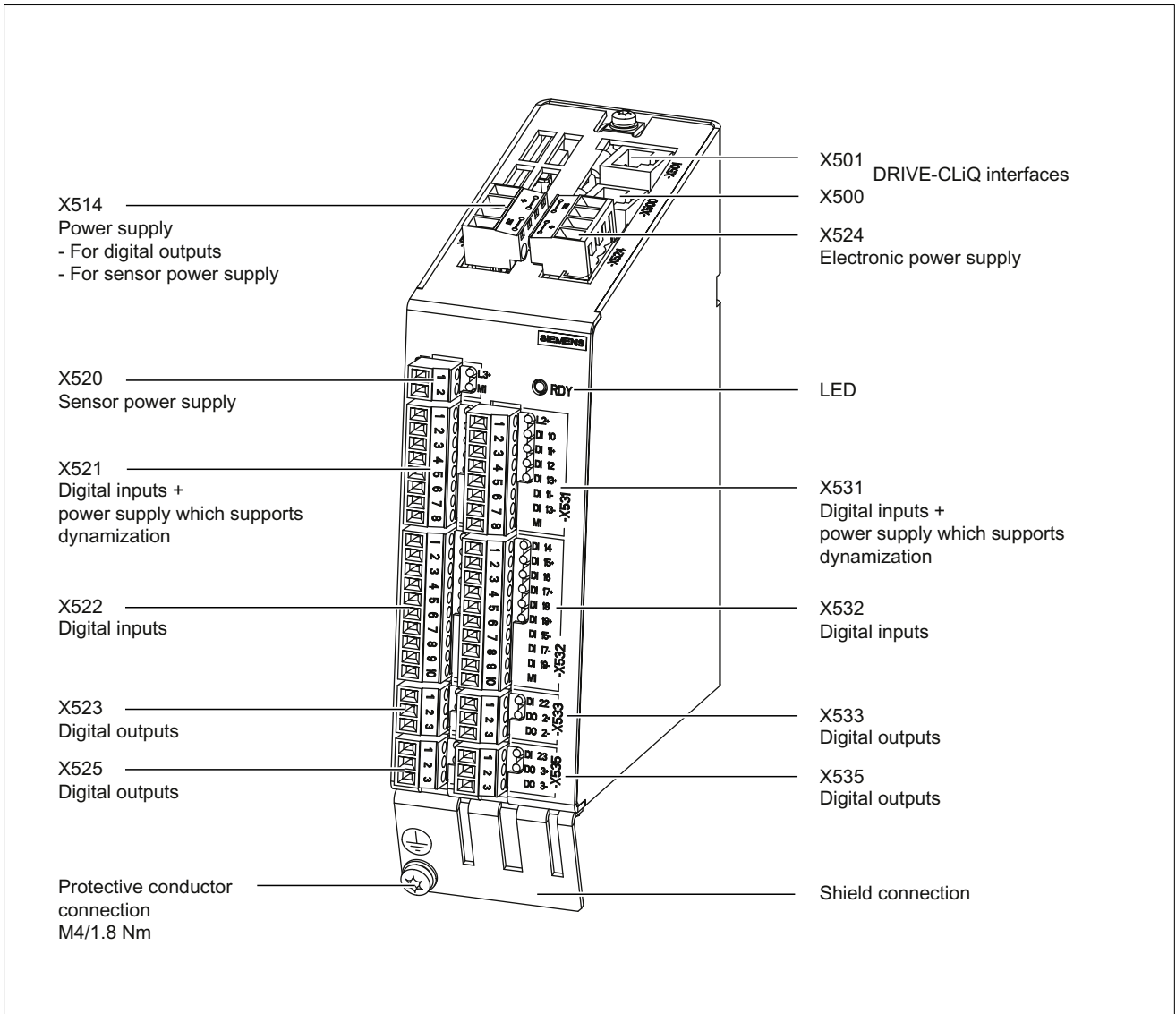

Figure 3-38 Interface description of the TM54F

3.9.3.2 Connection example

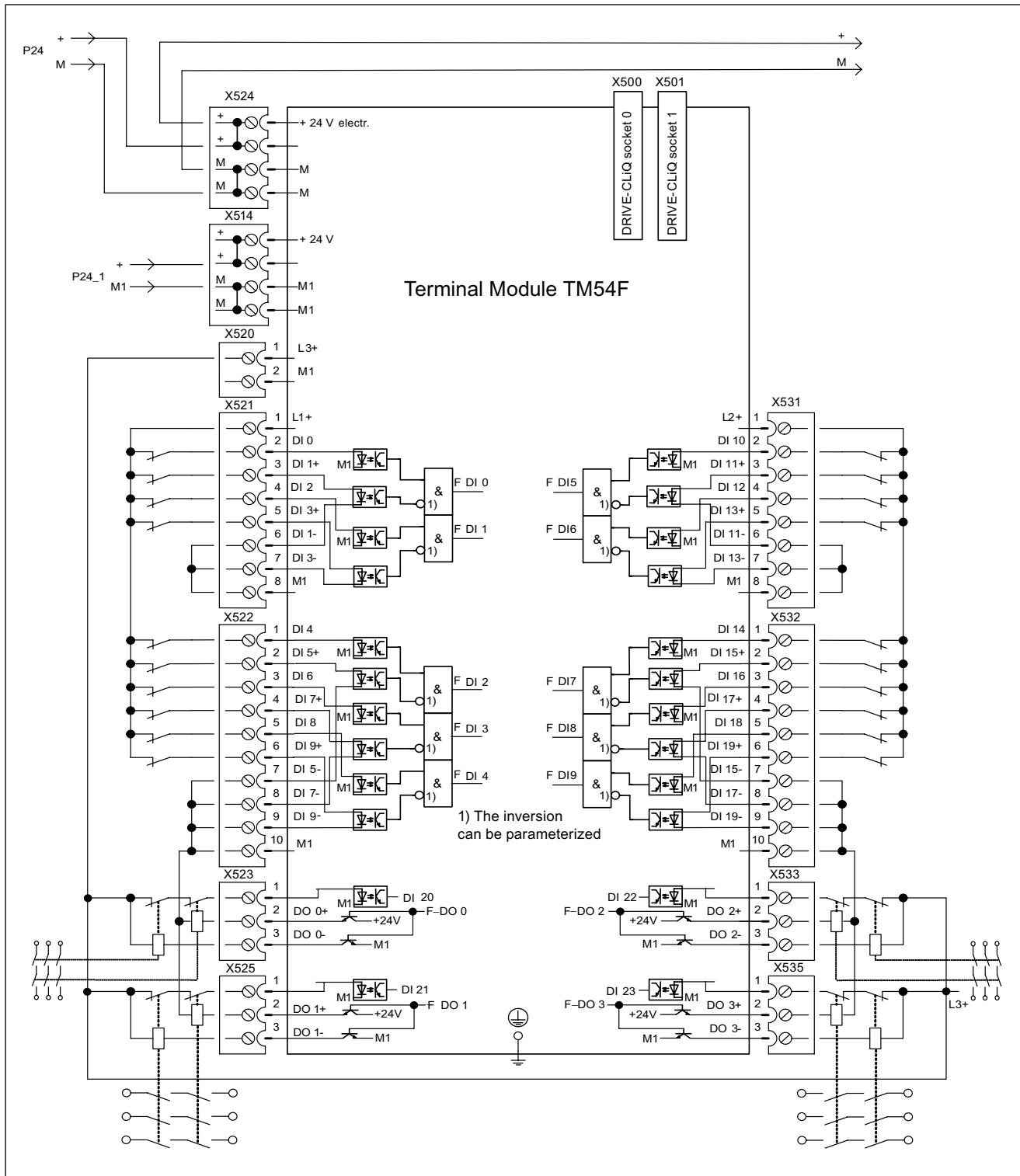

Figure 3-39 Connection example off TM54F

Additional circuit examples are included in:

- SINAMICS S120 Safety Integrated Function Manual
- System Manual: The safety program for world industry, order number: 6ZB5000-0AA01-0BA1, 5 Edition, Supplement: 6ZB5000-0AB01-0BA0

3.9.3.3 X500 and X501 DRIVE-CLiQ interface

Table 3- 52 DRIVE-CLiQ interfaces X500 and X501

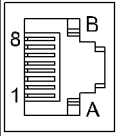
	Pin	Signal name	Technical specifications
	1	TXP	Transmit data +
	2	TXN	Transmit data -
	3	RXP	Receive data +
	4	Reserved, do not use	
	5	Reserved, do not use	
	6	RXN	Receive data -
	7	Reserved, do not use	
	8	Reserved, do not use	
	A	+ (24 V)	Power supply
	B	M (0 V)	Electronics ground
Blanking plate for DRIVE-CLiQ interfaces included in the scope of delivery; blanking plate (50 pieces) order number: 6SL3066-4CA00-0AA0			

3.9.3.4 X514 power supply for digital outputs and sensors

Table 3- 53 Terminals for the power supply X514

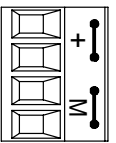
	Terminal	Designation	Technical specifications
	+	Power supply	Voltage: 24 V DC (20.4 V – 28.8 V) Current consumption: max. 4 A ¹⁾ Max. current via jumper in connector: 20 A
	+	Power supply	
	M1	Electronics ground	
	M1	Electronics ground	
Max. connectable cross-section: 2.5 mm ² Type: Screw terminal 2 (see Appendix A)			

Note

The two "+" and "M1" terminals are jumpered in the connector. This ensures that the supply voltage is looped through.

¹⁾ including the current consumption for the digital outputs and to supply the sensor.

3.9.3.5 X520 sensor power supply

Table 3- 54 Terminal X520

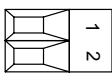
	Terminal	Designation	Technical specifications
	1	L3	500 mA, 24 V
	2	M1	

Without forced dormant error detection

3.9.3.6 X521 digital inputs + power supply with forced dormant error detection

Table 3- 55 Screw terminal X521

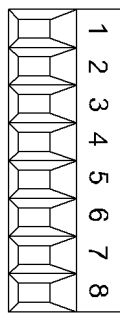
	Terminal	Designation ¹⁾	Technical specifications
	1	L1+	Voltage: +24 V DC Max. total load current: 500 mA
	2	DI 0	Voltage: - 3 V to +30 V Typical current consumption: 3.2 mA at 24 V DC Electrical isolation: Reference potential, refer to terminals 6, 7, 8 All digital inputs are electrically isolated. Input delay: ²⁾ - for "0" to "1": 30 µs (100 Hz) - for "1" to "0": 60 µs (100 Hz) Level (incl. ripple) High level: 15 V to 30 V Low level: -3 V to +5 V
	3	DI 1+	
	4	DI 2	
	5	DI 3+	
	6	DI 1-	Reference potential for DI 1+
	7	DI 3-	Reference potential for DI 3+
	8	M1	Reference potential for DI 0, DI 2, L1+

An F-DI comprises a digital input and a 2nd digital input where, in addition, the cathode of the optocoupler is fed-out.
 F-DI 0 = terminals 2, 3 and 6
 F-DI 1 = terminals 4, 5 and 7

Max. connectable cross-section: 1.5 mm²
 Type: Screw terminal 1 (see Appendix A)

1) DI: digital input; M1: ground reference

2) Pure hardware delay

NOTICE
For the digital inputs DIx+ to function, the reference potential must be connected to input DIx in each case. This is achieved by: 1) Providing the ground reference of the digital inputs, or 2) A jumper between DIx and terminal M1.

3.9.3.7 X522 digital inputs

Table 3- 56 Screw terminal X522

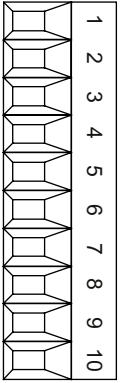
	Terminal	Designation ¹⁾	Technical specifications
	1	DI 4	Voltage: - 3 V to +30 V Typical current consumption: 3.2 mA at 24 V DC Electrical isolation: Reference potential, refer to terminals 7, 8, 9, 10 All digital inputs are electrically isolated. Input delay: ²⁾ - for "0" to "1": 30 µs (100 Hz) - for "1" to "0": 60 µs (100 Hz) Level (incl. ripple) High level: 15 V to 30 V Low level: -3 V to +5 V
	2	DI 5+	
	3	DI 6	
	4	DI 7+	
	5	DI 8	
	6	DI 9+	
	7	DI 5-	Reference potential for DI 5+
	8	DI 7-	Reference potential for DI 7+
	9	DI 9-	Reference potential for DI 9+
	10	M1	Reference potential for DI 4, DI 6 and DI 8
An F-DI comprises a digital input and a 2nd digital input where, in addition, the cathode of the optocoupler is fed-out. F-DI 2 = terminals 1, 2 and 7 F-DI 3 = terminals 3, 4 and 8 F-DI 4 = terminals 5, 6 and 9			
Max. connectable cross-section: 1.5 mm ² Type: Screw terminal 1 (see Appendix A)			

1) DI: digital input; M1: ground reference

2) Pure hardware delay

NOTICE

For the digital inputs DIx+ to function, the reference potential must be connected to input DIx in each case.

This is achieved by:

- 1) Providing the ground reference of the digital inputs, or
- 2) A jumper between DIx and terminal M1.

3.9.3.8 X523 digital outputs

Table 3- 57 Screw terminal X523

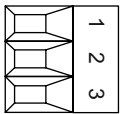
	Terminal	Designation ¹⁾	Technical specifications
	1	DI 20	Voltage: - 3 V to +30 V Typical current consumption: 3.2 mA at 24 V DC Electrical isolation: Reference potential is Terminal M1 The digital input is electrically isolated. Input delay: ²⁾ - for "0" to "1": 30 µs (100 Hz) - for "1" to "0": 60 µs (100 Hz) Level (incl. ripple) High level: 15 V to 30 V Low level: -3 V to 5 V
	2	DO 0+	0.5 A Reference potential is terminal M1
	3	DO 0-	0.5 A Reference potential is L1+, L2+ or L3+ Output delay: ²⁾ - for "0" to "1": 300 µs - for "1" to "0": 350 µs Total current consumption of all DOs: 2 A Max. leakage current: < 0.5 mA Switching frequency: For resistive load: Max. 100 Hz For inductive load: Max. 0.5 Hz For lamp load: Max. 10 Hz Maximum lamp load: 5 W
An F-DO comprises two digital outputs and a digital input to feed back the signal F-DO 0 = terminals 1, 2 and 3 Max. connectable cross-section: 1.5 mm ² Type: Screw terminal 1 (see Appendix A)			

1) DI: digital input; DO: digital output

2) Pure hardware delay

3.9.3.9 X524 Electronics power supply

Table 3- 58 Terminals for the electronics power supply

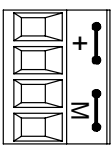
	Terminal	Designation	Technical specifications
	+	Electronics power supply	Voltage: 24 V DC (20.4 V – 28.8 V) Current consumption: Max. 0.7 A
	+	Electronics power supply	
	M	Electronics ground	Max. current via jumper in connector: 20 A
	M	Electronics ground	
Max. connectable cross-section: 2.5 mm ² Type: Screw terminal 2 (see Appendix A)			

Note

The two "+" and "M" terminals are jumpered in the connector. This ensures that the supply voltage is looped through.
The current consumption increases by the value for the DRIVE-CLiQ node.

3.9.3.10 X525 digital outputs

Table 3- 59 Screw terminal X525

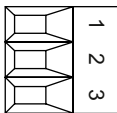
	Terminal	Designation ¹⁾	Technical specifications
	1	DI	Voltage: - 3 V to +30 V Typical current consumption: 3.2 mA at 24 V DC Electrical isolation: Reference potential is terminal M1 The digital input is electrically isolated. Input delay: ²⁾ - for "0" to "1": 30 µs (100 Hz) - for "1" to "0": 60 µs (100 Hz) Level (incl. ripple) High level: 15 V to 30 V Low level: -3 V to 5 V
	2	DO 1+	0.5 A Reference potential is terminal M1
	3	DO 1-	0.5 A Reference potential is terminal L1+, L2+ or L3+ Output delay: ²⁾ - for "0" to "1": 300 µs - for "1" to "0": 350 µs Total current consumption of all DOs: 2 A Max. leakage current: < 0.5 mA Switching frequency: For resistive load: Max. 100 Hz For inductive load: Max. 0.5 Hz For lamp load: Max. 10 Hz Maximum lamp load: 5 W
An F-DO comprises two digital outputs and a digital input F-DO 1 = terminals 1, 2 and 3:			
Max. connectable cross-section: 1.5 mm ² Type: Screw terminal 1 (see Appendix A)			

1) DI: digital input; DO: digital output

2) Pure hardware delay

3.9.3.11 X531 digital inputs + power supply with forced dormant error detection

Table 3- 60 Screw terminal X531

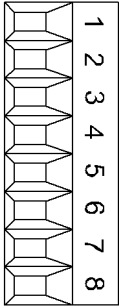
	Terminal	Designation ¹⁾	Technical specifications
	1	L 2+	Voltage: +24 V DC Max. total load current: 500 mA
	2	DI 10	Voltage: - 3 V to +30 V Typical current consumption: 3.2 mA at 24 V DC Electrical isolation: Reference potential, refer to terminals 6, 7, 8 All digital inputs are electrically isolated. Input delay: ²⁾ - for "0" to "1": 30 µs (100 Hz) - for "1" to "0": 60 µs (100 Hz) Level (incl. ripple) High level: 15 V to 30 V Low level: -3 V to 5 V
	3	DI 11+	
	4	DI 12	
	5	DI 13+	
	6	DI 11-	
	7	DI 13-	Reference potential to DI 13+
	8	M1	Reference potential to DI 10, DI 12, L2+
An F-DI comprises a digital input and a 2nd digital input where, in addition, the cathode of the optocoupler is fed-out. F-DI 5 = terminals 2, 3 and 6 F-DI 6 = terminals 4, 5 and 7			
Max. connectable cross-section: 1.5 mm ² Type: Screw terminal 1 (see Appendix A)			

1) DI: digital input; M1: ground reference

2) Pure hardware delay

NOTICE

For the digital inputs DIx+ to function, the reference potential must be connected to input DIx in each case.

This is achieved by:

- 1) Providing the ground reference of the digital inputs, or
- 2) A jumper between DIx and terminal M1.

3.9.3.12 X532 digital inputs

Table 3- 61 Screw terminal X532

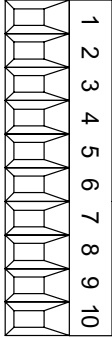
	Terminal	Designation ¹⁾	Technical specifications	
	1	DI 14	Voltage: - 3 V to +30 V Typical current consumption: 3.2 mA at 24 V DC Electrical isolation: Reference potential, refer to terminals 7, 8, 9, 10. All digital inputs are electrically isolated. Input delay: ²⁾ - for "0" to "1": 30 µs (100 Hz) - for "1" to "0": 60 µs (100 Hz) Level (incl. ripple) High level: 15 V to 30 V Low level: -3 V to +5 V	
	2	DI 15+		
	3	DI 16		
	4	DI 17+		
	5	DI 18		
	6	DI 19+		
	7	DI 15-		Reference potential to DI 15+
	8	DI 17-		Reference potential to DI 17+
	9	DI 19-		Reference potential to DI19+
	10	M1		Reference potential to DI14, DI16, DI18
An F-DI comprises a digital input and a 2nd digital input where, in addition, the cathode of the optocoupler is fed out. F-DI 7 = terminals 1, 2 and 7 F-DI 8 = terminals 3, 4 and 8 F-DI 9 = terminals 5, 6 and 9 Max. connectable cross-section: 1.5 mm ² Type: Screw terminal 1 (see Appendix A)				

1) DI: digital input; M1: ground reference

2) Pure hardware delay

NOTICE

For the digital inputs DIx+ to function, the reference potential must be connected to input DIx in each case.

This is achieved by:

- 1) Providing the ground reference of the digital inputs, or
- 2) A jumper between DIx and terminal M1.

3.9.3.13 X533 digital outputs

Table 3- 62 Screw terminal X533

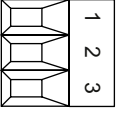
	Terminal	Designation ¹⁾	Technical specifications
	1	DI 22	Voltage: - 3 V to +30 V Typical current consumption: 3.2 mA at 24 V DC Electrical isolation: Reference potential is terminal M1 The digital input is electrically isolated. Input delay: ²⁾ - for "0" to "1": 30 µs (100 Hz) - for "1" to "0": 60 µs (100 Hz) Level (incl. ripple) High level: 15 V to 30 V Low level: -3 V to 5 V
	2	DO+	0.5 A Reference potential is terminal M1
	3	DO-	0.5 A Reference potential is terminal L1+, L2+ or L3+ Output delay: ²⁾ - for "0" to "1": 300 µs - for "1" to "0": 350 µs Total current consumption of all DOs: 2 A Max. leakage current: < 0.5 mA Switching frequency: For resistive load: Max. 100 Hz For inductive load: Max. 0.5 Hz For lamp load: Max. 10 Hz Maximum lamp load: 5 W
An F-DO comprises two digital outputs and a digital input for the feedback signal F-DO 2 = terminals 1, 2 and 3 Max. connectable cross-section: 1.5 mm ² Type: Screw terminal 1 (see Appendix A)			

1) DI: digital input; DO: digital output

2) Pure hardware delay

3.9.3.14 X535 digital outputs

Table 3- 63 X535 digital inputs/outputs

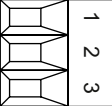
	Terminal	Designation ¹⁾	Technical specifications
	1	DI 23	Voltage: - 3 V to +30 V Typical current consumption: 3.2 mA at 24 V DC Electrical isolation: Reference potential is terminal M1 The digital input is electrically isolated. Input delay: ²⁾ - for "0" to "1": 30 µs (100 Hz) - for "1" to "0": 60 µs (100 Hz) Level (incl. ripple) High level: 15 V to 30 V Low level: -3 V to 5 V
	2	DO 3+	0.5 A Reference potential is terminal M1
	3	DO 3-	0.5 A Reference potential is terminal L1+, L2+ or L3+ Output delay: ²⁾ - for "0" to "1": 300 µs - for "1" to "0": 350 µs Total current consumption of all DOs: 2 A Max. leakage current: < 0.5 mA Switching frequency: For resistive load: Max. 100 Hz For inductive load: Max. 0.5 Hz For lamp load: Max. 10 Hz Maximum lamp load: 5 W
An F-DO comprises two digital outputs and a digital input for the feedback signal F-DO 3 = terminals 1, 2 and 3 Max. connectable cross-section: 1.5 mm ² Type: Screw terminal 1 (see Appendix A)			

1) DI: digital input; DO: digital output

2) Pure hardware delay

3.9.3.15 Meaning of the LEDs on the Terminal Module TM54F

Table 3- 64 Terminal Module TM54F - description of LEDs

LED	Color		Status	Description, cause	Remedy
READY	-		Off	Electronics power supply is missing or outside permissible tolerance range.	-
	Green		Continuous light	The component is ready for operation and cyclic DRIVE-CLiQ communication is taking place.	-
	Orange		Continuous light	DRIVE-CLiQ communication is being established.	-
	Red		Continuous light	At least one fault is present in this component. Note: The LED is activated regardless of whether the corresponding messages have been reconfigured.	Remedy and acknowledge fault
	Green/red		0.5 Hz flashing light	Firmware is being downloaded.	-
			2 Hz flashing light	Firmware download is complete. Wait for POWER ON	Carry out a POWER ON
	Green/orange or Red/orange		Flashing light	Component recognition via LED is activated (p0154). Note: Both options depend on the LED status when component recognition is activated via p0154 = 1.	-
L1+, L2+,	-		ON	The controllable sensor power supply is functioning fault-free.	-
	Red		Continuous light	There is a fault in the controllable sensor power supply.	-
L3+	-		ON	Sensor power supply is functioning fault-free.	
	Red		Continuous light	There is a fault in the sensor power supply.	
Fail-safe inputs / double inputs					
F_DI z (input x, (x+1)+, (x+1)-)	LED x	LED x+1	Continuous light	NC contact / NC contact ¹⁾ : (z = 0..9, x = 0, 2, ..18) Different signal states at input x and x+1 No signal at input x and no signal at input x+1	-
	-	Red			
	-	Red	Continuous light	NC contact / NO contact ¹⁾ : (z = 0..9, x = 0, 2, ..18) Same signal states at input x and x+1 No signal at input x and a signal at input x+1	
	-	-			
LED x	LED x+1	Continuous light	NC contact / NC contact ¹⁾ : (z = 0..9, x = 0, 2, ..18) A signal at input x and a signal at input x+1	-	
Green	Green				
Green	Green	Continuous light	NC contact / NO contact ¹⁾ : (z = 0..9, x = 0, 2, ..18) A signal at input x and no signal at input x+1		
¹⁾ Inputs x+1 (DI 1+, 3+, .. 19+) can be set individually via parameter p10040. p10040 = 0: Input x+1 ist NC contact. p10040 = 1: Input x+1 is NO contact. Factory setting: p10040 = 0 for all inputs x+1.					

LED	Color	Status	Description, cause	Remedy
Single digital inputs, not fail-safe				
DI x	–	Off	No signal at digital input x (x = 20..23)	–
	Green	Continuous light	Signal at digital input x	–
Fail-safe digital outputs with associated readback channel				
F_DO y (0+..3+, 0-..3-)	Green	Continuous light	Output y (y=0 .. 3) carries a signal	–
Readback input DI 2y for output F_DO y (y = 0..3) at test stop. The state of the LEDs also depends on the type of external circuit.				
DI 2y	–	Off	One of the two output lines y+ or y- or both lines of output y carry a signal	–
	Green	Continuous light	Both output lines y+ and y- carry no signal	–

Cause and rectification of faults

The following reference contains information about the cause of faults and how they can be rectified:

/IH1/ SINAMICS S120 Commissioning Manual

/LH1/ SINAMICS S List Manual

3.9.4 Dimension drawing

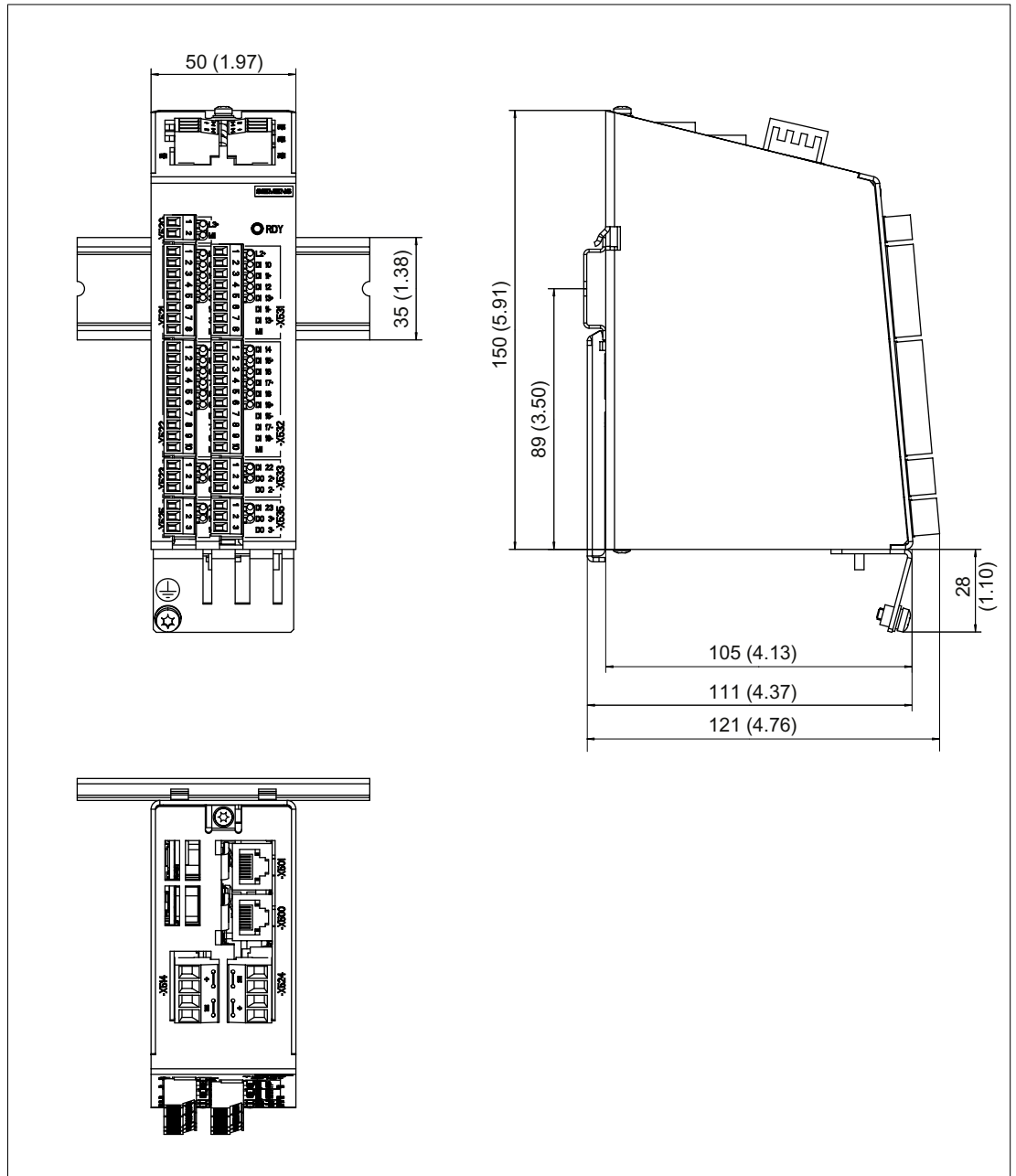

Figure 3-40 Dimension drawing of Terminal Module TM54F, all data in mm and (inches)

3.9.5 Installation

Installation

1. Tilt the component backwards slightly and attach it to the DIN rail using the hook.
2. Push the component towards the DIN rail until you hear the mounting slide at the rear latch into position.
3. You can now move the component to the left or right along the DIN rail, until it reaches its final position.

Removal

1. The lug on the mounting slide first needs to be pushed down to unlock the slide from the DIN rail.
2. The component can now be tilted forwards and pulled up and off the DIN rail.

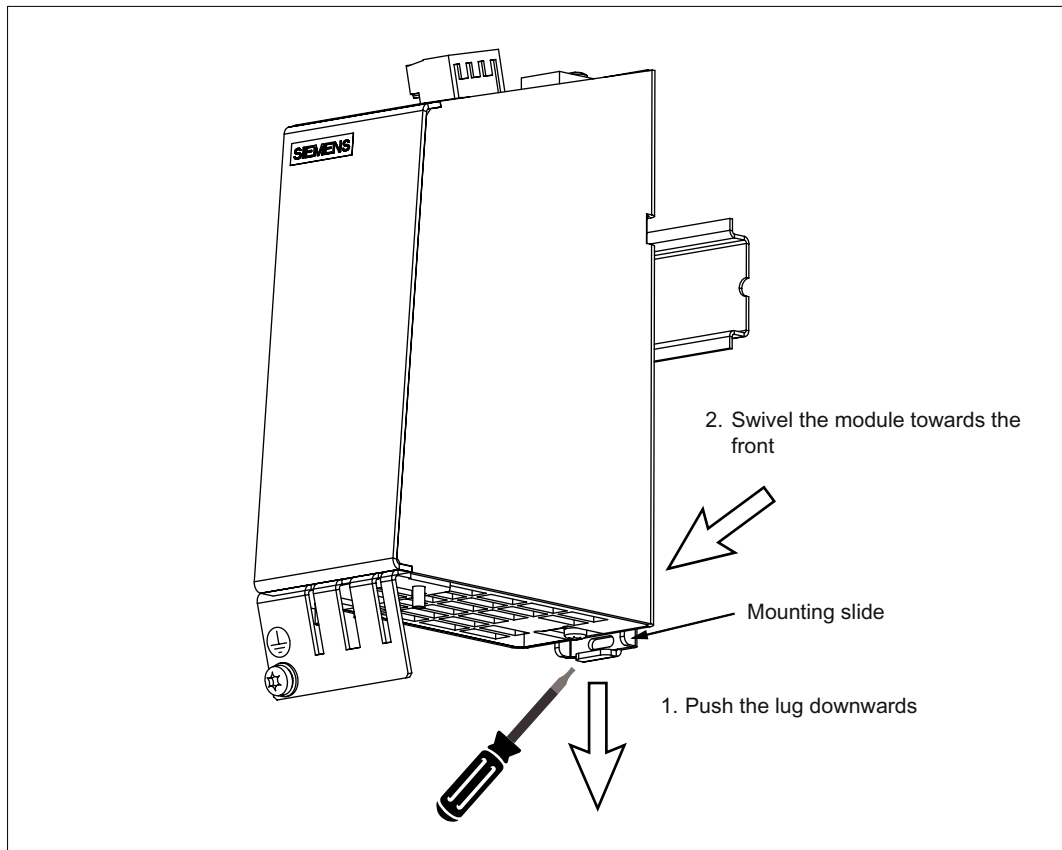

Figure 3-41 Removal of a component from a DIN rail

3.9.6 Protective conductor connection and shield support

It is always advisable to shield the digital I/O wiring.

The following figure shows typical Weidmüller shield connection clamps for the shield supports.

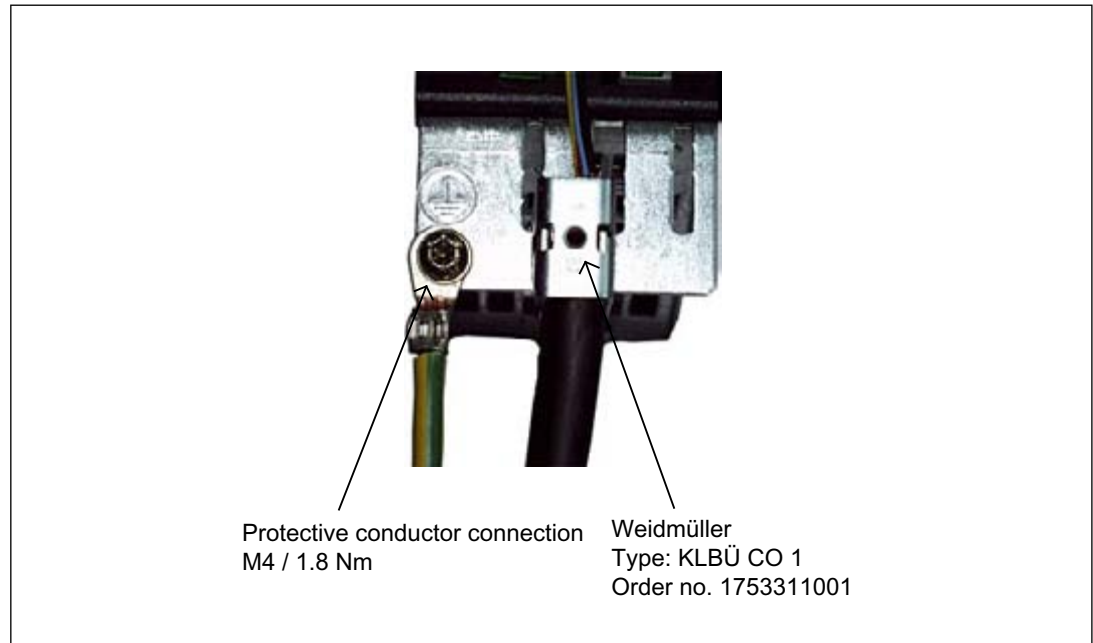

Figure 3-42 Shield supports and protective conductor connection

Weidmüller website address: <http://www.weidmueller.com>

⚠ DANGER

If the shielding procedures described and the specified cable lengths are not observed, the machine may not operate properly.

NOTICE

Only use screws with a permissible mounting depth of 4 - 6 mm.

3.9.7 Technical data

Table 3- 65 Technical data

6SL3055-0AA00-3BAx	Unit	Value
Current requirement (X524 at 24 V DC) without DRIVE-CLiQ supply	mA	160
Current requirement (X514 at 24 V DC) without digital outputs and sensor power supply	mA	38
Sensor power supply with and without forced dormant error detection (L1+, L2+, L3+)		
• Voltage	V	24
• Max. load current per output	A	0.5
- cable length for the 24 V power supply: - For longer cable lengths, the "Weidmüller Type No. PU DS 24 16A" surge protector must be used.	m	< 30
• Fail-safe digital inputs (F-DI) (with electrical isolation)		10
• Fail-safe digital outputs (F-DO) (with electrical isolation)		4
• Standard digital inputs (with electrical isolation)		4
Fail-safe digital inputs (F-DI) and standard digital inputs		
• Voltage	V	0 to 30
• Low-level (an open digital input is interpreted as "low")	V	-3 to +5
• High level		
• Current consumption (at 24 V DC)	V	15 to 30
• Input delay ¹⁾	mA	>2
– for "0" to "1"	µs	approx. 30 (100 Hz)
– for "1" to "0"	µs	approx. 60 (100 Hz)
Fail-safe digital outputs (F-DO), continuous short-circuit proof		
• Voltage	V	24
• Max. load current per digital output	A	0.5
• Output delay ¹⁾		
– for "0" to "1"	µs	300
– for "1" to "0"	µs	350
Power loss	W	4.5 at 24 V
PE/ground connection		On housing with M4 screw
Weight	kg	approx. 0.9

1) Pure hardware delay

3.10 Terminal Module TM120

3.10.1 Description

The Terminal Module TM120 is a DRIVE-CLiQ component for safe electrically isolated temperature evaluation. It can be used for 1FN, 1FW6, and third-party motors in which the temperature sensors cannot be installed with safe electrical separation. The TM120 is installed in the control cabinet and can be snapped on to a DIN rail (EN 60715).

When a TM120 is being used, temperature evaluation and encoder evaluation functions are separated off from one another. The TM120 can detect the motor temperature via four channels with different temperature sensors. Encoder evaluation functions are performed via Sensor Modules (e.g. SMCxx, SMExx). This means that, when connected to a Sensor Module SMCxx, the TM120 represents an alternative control cabinet to the SME120/SME125.

The TM120 can be operated with firmware version 4.3 or higher, in conjunction with a CU320-2 DP.

The TM120 contains the following interfaces:

Table 3- 66 Overview of the TM120 interfaces

Type	Quantity
DRIVE-CLiQ interfaces	2
Temperature sensor inputs	4

3.10.2 Safety information

WARNING

The ventilation spaces of 50 mm above and below the component must be observed.

CAUTION

Connecting cables to temperature sensors must always be installed with shielding. The cable shield must be connected to the ground potential at both ends over a large surface area. Temperature sensor cables that are routed together with the motor cable must be twisted in pairs and shielded separately.

NOTICE

If sensors other than those specified are connected, this may result in incorrect measured values.

3.10.3 Interface description

3.10.3.1 Overview

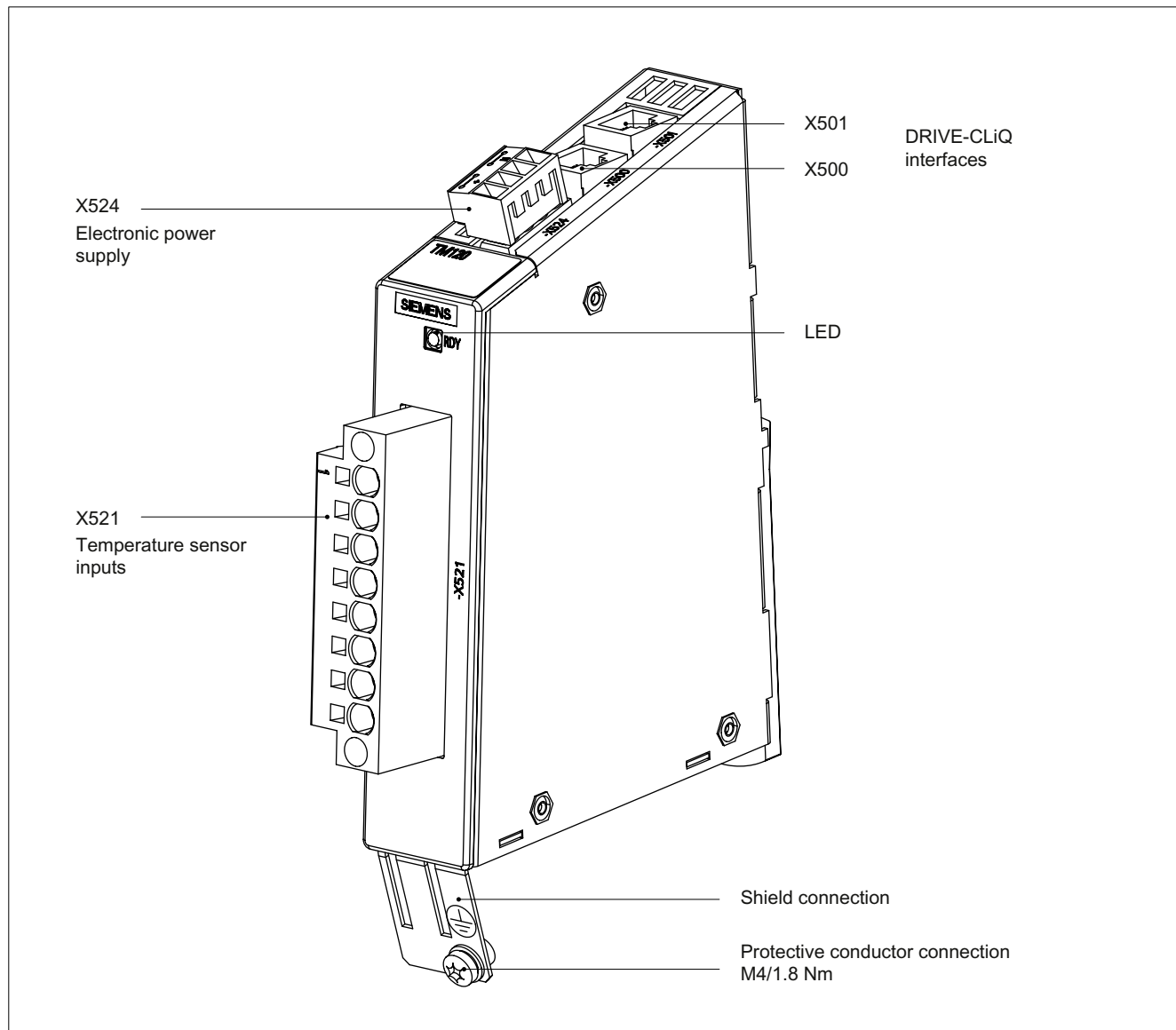

Figure 3-43 Interface description of the TM120

3.10.3.2 Connection examples

Each TM120 is directly connected to an encoder evaluation unit (SMCxx or SMExx) by looping the corresponding DRIVE-CLiQ channel via the TM120. This ensures that encoders are automatically assigned to the temperature signals and, consequently, to the correct axis. The assignment can also be performed manually.

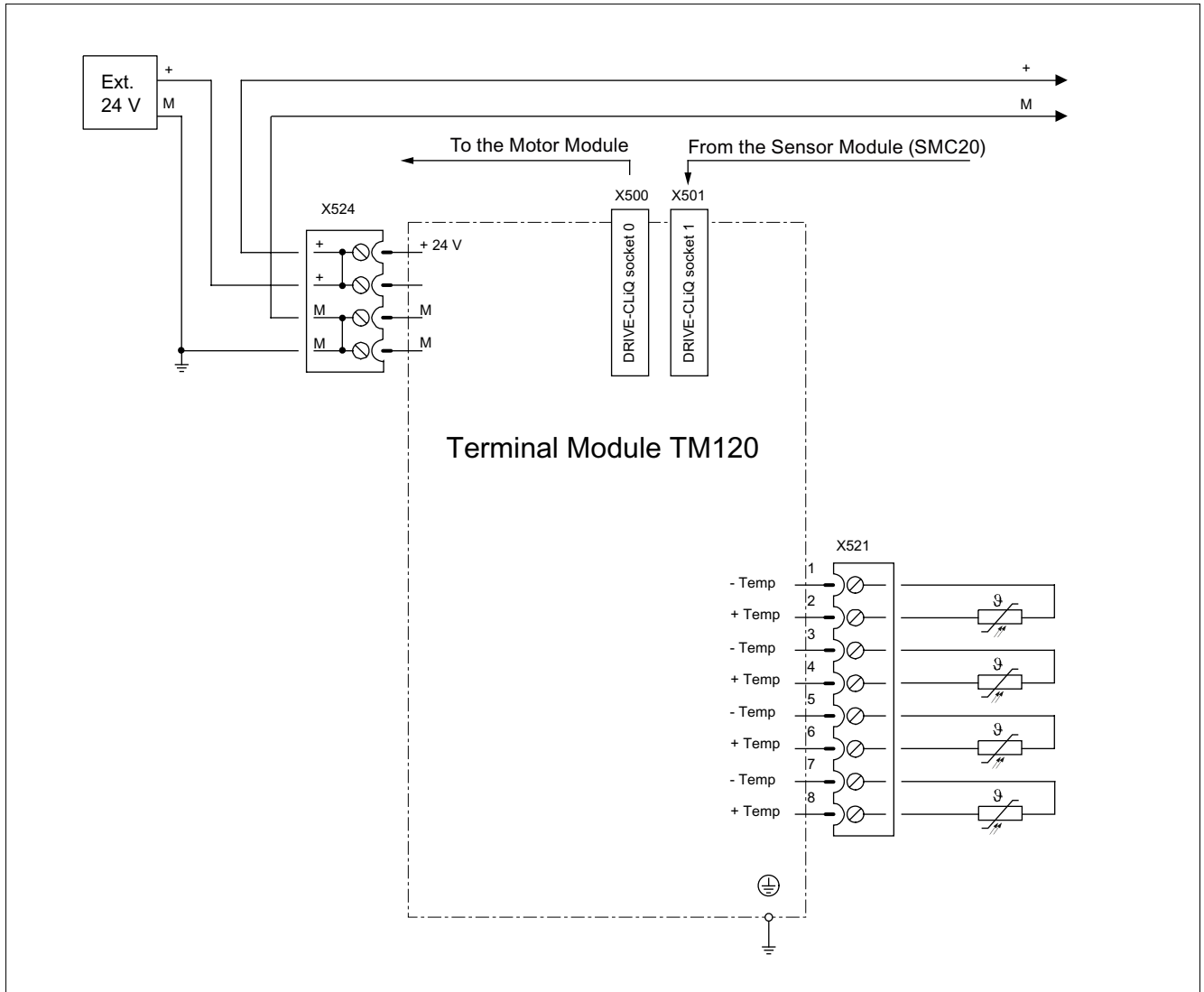

Figure 3-44 Connection example of TM120

3.10 Terminal Module TM120

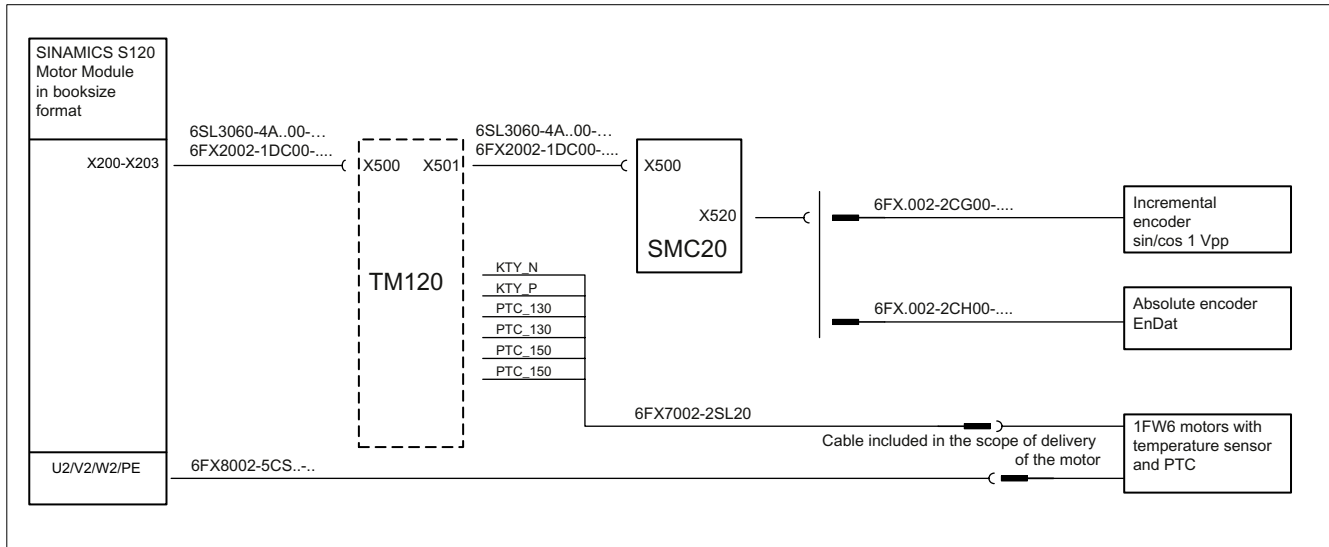

Figure 3-45 Connection example of TM120 with Motor Module and SMC20 (encoder evaluation)

3.10.3.3 X500 and X501 DRIVE-CLiQ interface

Table 3- 67 DRIVE-CLiQ interfaces X500 and X501

	Pin	Signal name	Technical specifications
	1	TXP	Transmit data +
	2	TXN	Transmit data -
	3	RXP	Receive data +
	4	Reserved, do not use	
	5	Reserved, do not use	
	6	RXN	Receive data -
	7	Reserved, do not use	
	8	Reserved, do not use	
	A	+ (24 V)	Power supply
	B	M (0 V)	Electronics ground

Connector type: RJ34plus socket; blanking plate for DRIVE-CLiQ interfaces included in the scope of delivery; blanking plate (50 pieces) order number: 6SL3066-4CA00-0AA0

NOTICE

The maximum DRIVE-CLiQ cable length is 100 m.

3.10.3.4 X524 Electronics power supply

Table 3- 68 Terminals for the electronics power supply

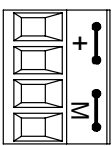
	Terminal	Designation	Technical specifications
	+	Electronics power supply	Voltage: 24 V DC (20.4 V – 28.8 V) Current consumption (max./typ.): 0.5 A/0.1 A
	+	Electronics power supply	
	M	Electronics ground	Max. current via jumper in connector: 20 A
	M	Electronics ground	
Max. connectable cross-section: 2.5 mm ² Type: Screw terminal 2 (see Appendix A)			

NOTICE

The maximum length of the power supply cable is 10 m.

Note

The two "+" and "M" terminals are jumpered in the connector. This ensures that the supply voltage is looped through.

The current consumption increases by the value for the DRIVE-CLiQ node.

3.10.3.5 X521 temperature sensor input

Table 3- 69 X521 temperature sensor input

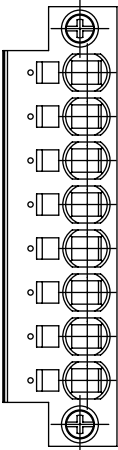
	Terminal	Function	Technical specifications
	1	- Temp	Temperature sensor connection KTY84-1C130/PTC/bimetallic switch with NC contact In linear motor applications, connect the KTY84-1C130 motor temperature sensor here
	2	+ Temp	
	3	- Temp	Temperature sensor connection KTY84-1C130/PTC/bimetallic switch with NC contact In linear motor applications, connect the PTC triple element 1 or bimetallic switch here
	4	+ Temp	
	5	- Temp	Temperature sensor connection KTY84-1C130/PTC/bimetallic switch with NC contact In linear motor applications, connect the PTC triple element 2 here
	6	+ Temp	
	7	- Temp	Temperature sensor connection KTY84-1C130/PTC/bimetallic switch with NC contact In linear motor applications, connect the PTC triple element 3 here
	8	+ Temp	

Max. connectable cross-section: 6 mm²

Type: Spring-loaded terminal 5 (see Appendix A)

Constant current per sensor approx. 2 mA

NOTICE

When connecting several temperature sensors, the individual sensors must be separately connected to "+ Temp" and "- Temp".

It is not permissible that the "+ Temp" and "- Temp" signals are interconnected with one another!

The table below shows the preferable assignment of the connecting terminal for the temperature sensor input:

Table 3- 70 Preferable assignment, X521 temperature sensor input

Terminal	Signal name				Meaning
	1FW6	1FN3 (2x1FN3)	1FN1	Segment motor 4 segments	
1	KTY N	KTY N	KTY N	1 PTC 120 °C	KTY, negative pole
2	KTY P	KTY P	KTY P	1 PTC 120 °C	
3	PTC 130 °C	PTC 120 °C	Bimetallic switch with NC contact	2_PTC 120 °C	PTC triple element 1 or bimetallic switch with NC contact
4	PTC 130 °C	PTC 120 °C	Bimetallic switch with NC contact	2_PTC 120 °C	
5	PTC 150 °C	(2_KTY_N)		3_PTC 120 °C	PTC triple element 2
6	PTC 150 °C	(2_KTY_P)		3_PTC 120 °C	
7		(2 PTC 120 °C)		4 PTC 120 °C	PTC triple element 3
8		(2 PTC 120 °C)		4 PTC 120 °C	

Note

The interconnection given is a suggestion (software default setting). Which sensor is connected to which input can be freely configured.

NOTICE

The maximum length of the sensor cable is 100 m. The cables must feature shielding.

Note

A 6FX7008-1BCx1 power cable is recommended for connecting the KTY temperature sensors.

3.10.3.6 Meaning of the LEDs on the Terminal Module TM120

Table 3- 71 Description of the LEDs on the TM120

LED	Color	Status	Description, cause	Remedy	
READY	-	Off	Electronics power supply is missing or outside permissible tolerance range.	Check power supply	
	Green	Continuous light	The component is ready for operation and cyclic DRIVE-CLiQ communication is taking place.	-	
	Orange	Continuous light	DRIVE-CLiQ communication is being established.	-	
	Red	Continuous light	At least one fault is present in this component. Note: The LED is activated regardless of whether the corresponding messages have been reconfigured.	Remedy and acknowledge fault	
	Green/ Red	0.5 Hz flashing light	Firmware is being downloaded.		-
			Firmware download is complete. Wait for POWER ON		Carry out a POWER ON
	Green/ orange or red/ orange	2 Hz flashing light	Detection of the components via LED is activated (p0154). Note: Both options depend on the LED status when module recognition is activated via p0154 = 1.		-

Cause and rectification of faults

The following reference contains information about the cause of faults and how they can be rectified:

/IH1/ SINAMICS S120 Commissioning Manual

/LH1/ SINAMICS S List Manual

3.10.4 Dimension drawing

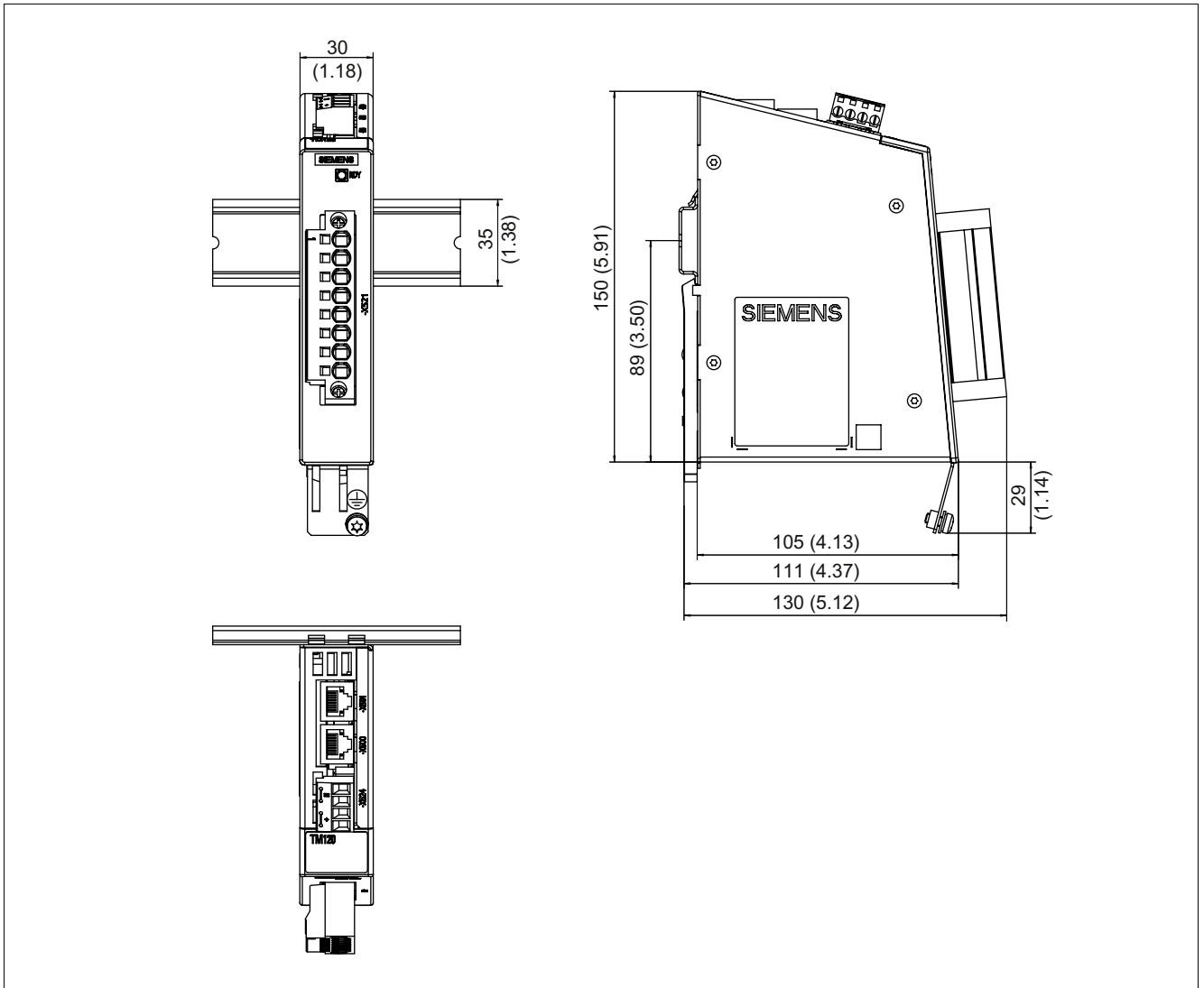

Figure 3-46 Dimension drawing of Terminal Module TM120, all data in mm and (inches)

3.10.5 Installation

Installation

1. Tilt the component backwards slightly and attach it to the DIN rail using the hook.
2. Push the component towards the DIN rail until you hear the mounting slide at the rear latch into position.
3. You can now move the component to the left or right along the DIN rail, until it reaches its final position.

Removal

1. The lug on the mounting slide first needs to be pushed down to unlock the slide from the DIN rail.
2. The component can now be tilted forwards and pulled up and off the DIN rail.

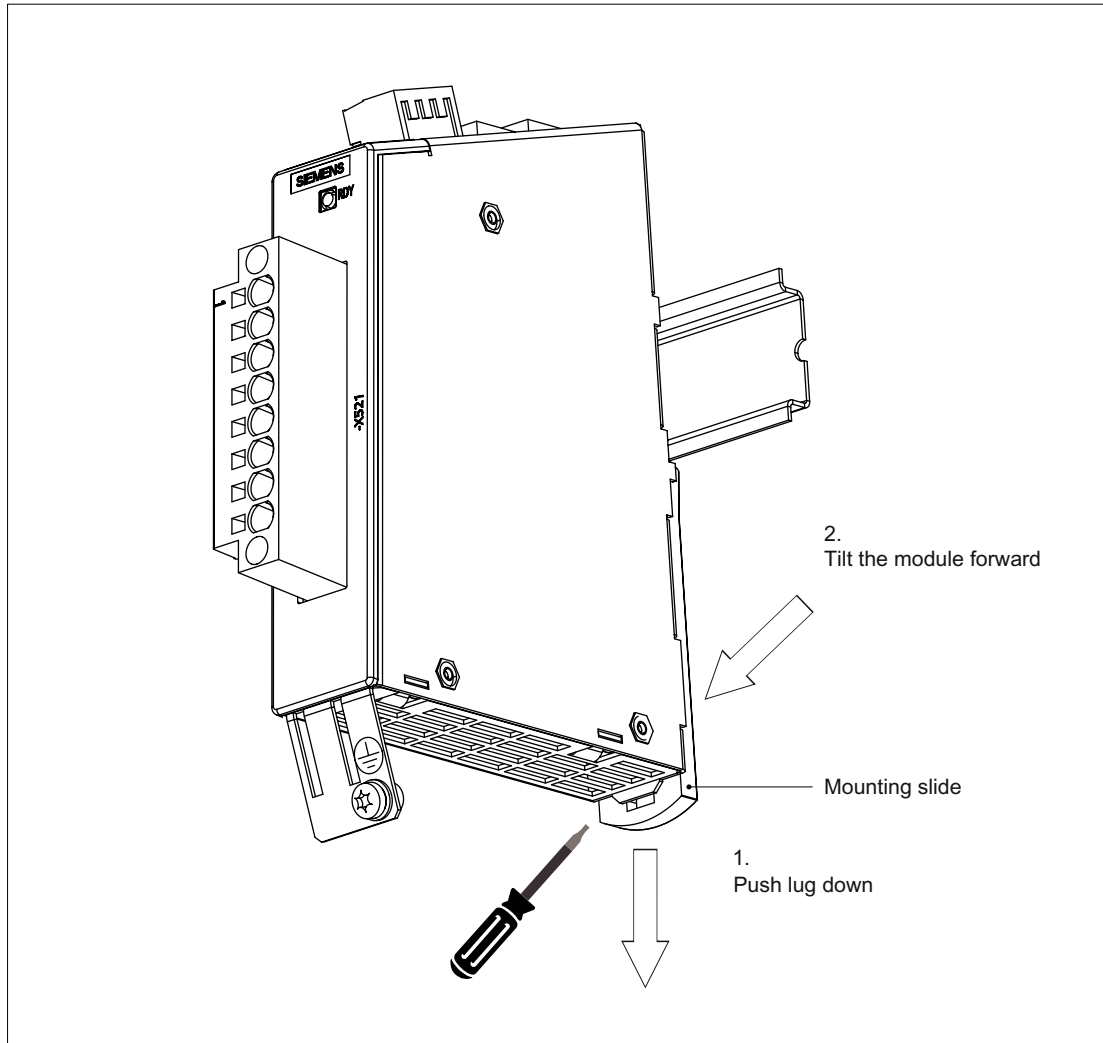

Figure 3-47 Removal of a TM120 from a DIN rail

3.10.6 Protective conductor connection and shield support

The following figure shows a typical Weidmüller shield connection clamp for the shield supports.

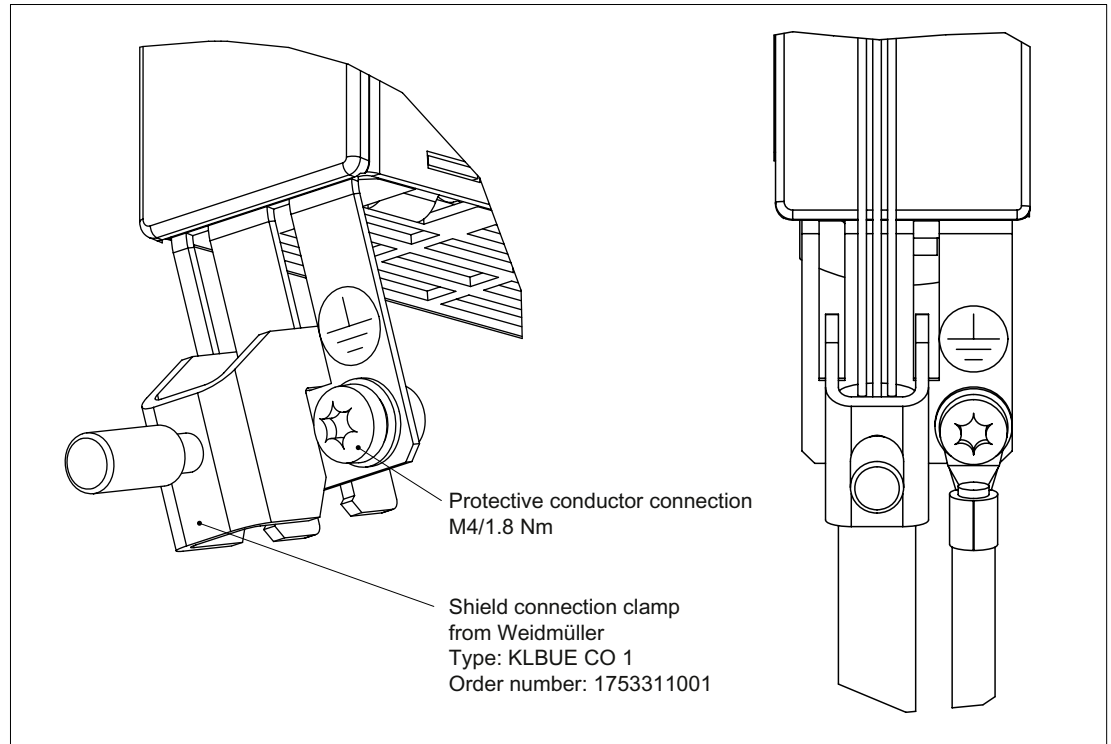

Figure 3-48 Shield support and protective conductor connection of the TM120

Weidmüller website address: <http://www.weidmueller.com>

⚠ DANGER

If the shielding procedures described and the specified cable lengths are not observed, the machine may not operate properly.

NOTICE

Only use screws with a permissible mounting depth of 4 - 6 mm.

3.10.7 Technical data

Table 3- 72 Technical data

6SL3055-0AA00-3KAx	Unit	Value
Electronics power supply		
Voltage	V _{DC}	24 DC (20.4 – 28.8)
Current (without DRIVE-CLiQ)	A _{DC}	0.20/0.1 (typ.)
Power loss	W	2.4 (typ.)
PE/ground connection	On housing with M4/1.8 Nm screw	
Weight	kg	0.41
Degree of protection	IP20	

NOTICE

In order to guarantee the degree of protection, all of the plug connectors must be correctly screwed into place and appropriately locked.

3.11 DRIVE-CLiQ Hub Module DMC20

3.11.1 Description

The DRIVE-CLiQ DMC20 Hub Module is used to implement star-shaped distribution of a DRIVE-CLiQ line. With the DMC20, an axis grouping can be expanded with four DRIVE-CLiQ sockets for additional subgroups.

The component is especially suitable for applications which require DRIVE-CLiQ nodes to be removed in groups, without interrupting the DRIVE-CLiQ line and, therefore, the data exchange process.

3.11.2 Safety information

 WARNING
The ventilation spaces of 50 mm above and below the component must be observed.

3.11.3 Interface description

3.11.3.1 Overview

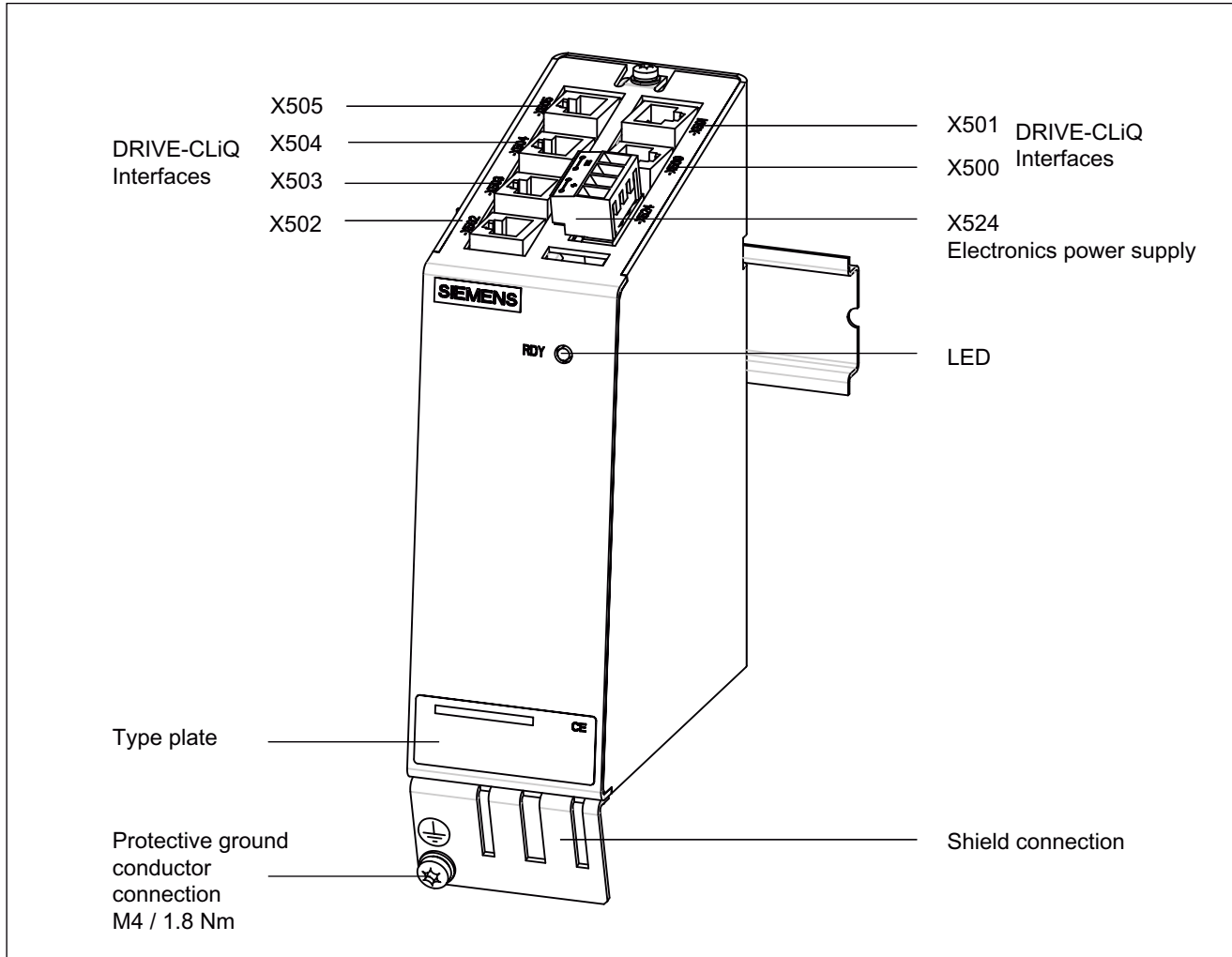
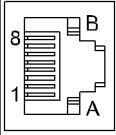

Figure 3-49 Interface description of the DMC20

3.11.3.2 X500 - X505 DRIVE-CLiQ interfaces

Table 3- 73 DRIVE-CLiQ interfaces X500 - X505

	Pin	Signal name	Technical specifications
	1	TXP	Transmit data +
	2	TXN	Transmit data -
	3	RXP	Receive data +
	4	Reserved, do not use	
	5	Reserved, do not use	
	6	RXN	Receive data -
	7	Reserved, do not use	
	8	Reserved, do not use	
	A	+ (24 V)	Power supply
	B	M (0 V)	Electronics ground

Connector type: RJ45 socket; blanking plate for DRIVE-CLiQ interfaces included in the scope of delivery; blanking plate (50 pieces) order number: 6SL3066-4CA00-0AA0

Note

Only MOTION-CONNECT DRIVE-CLiQ cables may be used to establish connections. The maximum length of MOTION-CONNECT 500 cables is 100 m and of MOTION-CONNECT 800 cables 50 m.

3.11.3.3 X524 Electronics power supply

Table 3- 74 Terminals for the electronics power supply

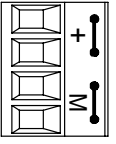
	Terminal	Designation	Technical specifications
	+	Electronics power supply	Voltage: 24 V DC (20.4 V – 28.8 V) Current consumption: Max. 0.5 A Max. current via jumper in connector: 20 A
	+	Electronics power supply	
	M	Electronics ground	
	M	Electronics ground	

Max. connectable cross-section: 2.5 mm²
Type: Screw terminal 2 (see Appendix A)

Note

The two "+" and "M" terminals are jumpered in the connector. This ensures that the supply voltage is looped through.

The current consumption increases by the value for the DRIVE-CLiQ participants.

3.11.3.4 Description of the LEDs on the DRIVE-CLiQ Hub Module DMC20

Table 3- 75 DRIVE-CLiQ Hub Module DMC20 – description of the LEDs

LED	Color	State	Description, cause	Remedy
READY	-	OFF	Electronics power supply is missing or outside permissible tolerance range.	-
	Green	Continuous	The component is ready for operation and cyclic DRIVE-CLiQ communication is taking place.	-
	Orange	Continuous	DRIVE-CLiQ communication is being established.	-
	Red	Continuous	At least one fault is present in this component. Note: The LED is activated regardless of whether the corresponding messages have been reconfigured.	Remedy and acknowledge fault
	Green/red	Flashing 0.5 Hz	Firmware is being downloaded.	-
		Flashing 2 Hz	Firmware download is complete. Wait for POWER ON	Carry out a POWER ON
	Green/orange or Red/orange	Flashing	Component recognition via LED is activated (p0154). Note: Both options depend on the LED status when component recognition is activated via p0154 = 1.	-

Cause and rectification of faults

The following reference contains information about the cause of faults and how they can be rectified:

/IH1/ SINAMICS S120 Commissioning Manual

/LH1/ SINAMICS S List Manual

3.11.4 Dimension drawing

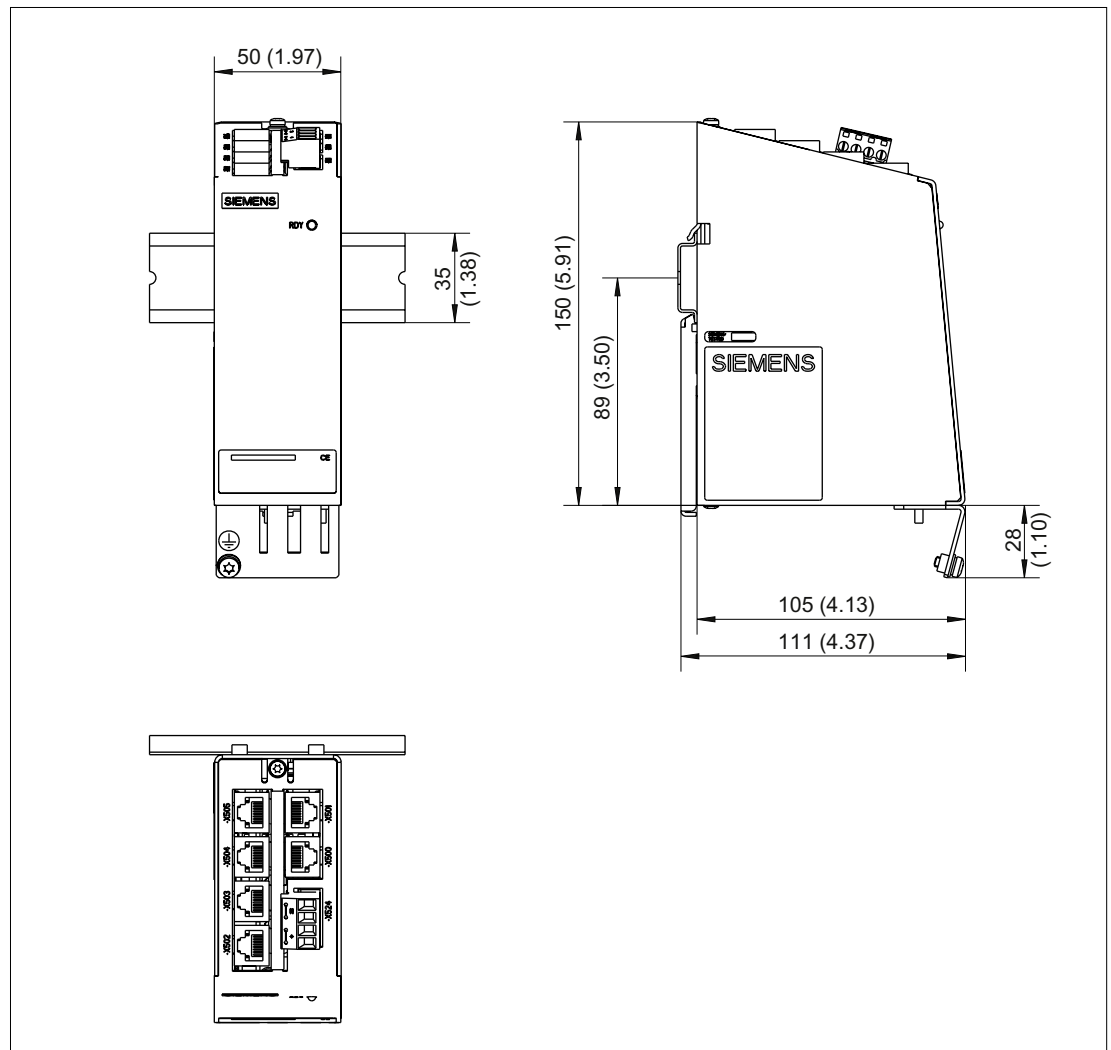

Figure 3-50 Dimension drawing of the DRIVE-CLiQ Hub Module DMC20, all data in mm and (inches)

3.11.5 Installation

Installation

1. Tilt the component backwards slightly and attach it to the DIN rail using the hook.
2. Push the component towards the DIN rail until you hear the mounting slide at the rear latch into position.
3. You can now move the component to the left or right along the DIN rail, until it reaches its final position.

Removal

1. The lug on the mounting slide first needs to be pushed down to unlock the slide from the DIN rail.
2. The component can now be tilted forwards and pulled up and off the DIN rail.

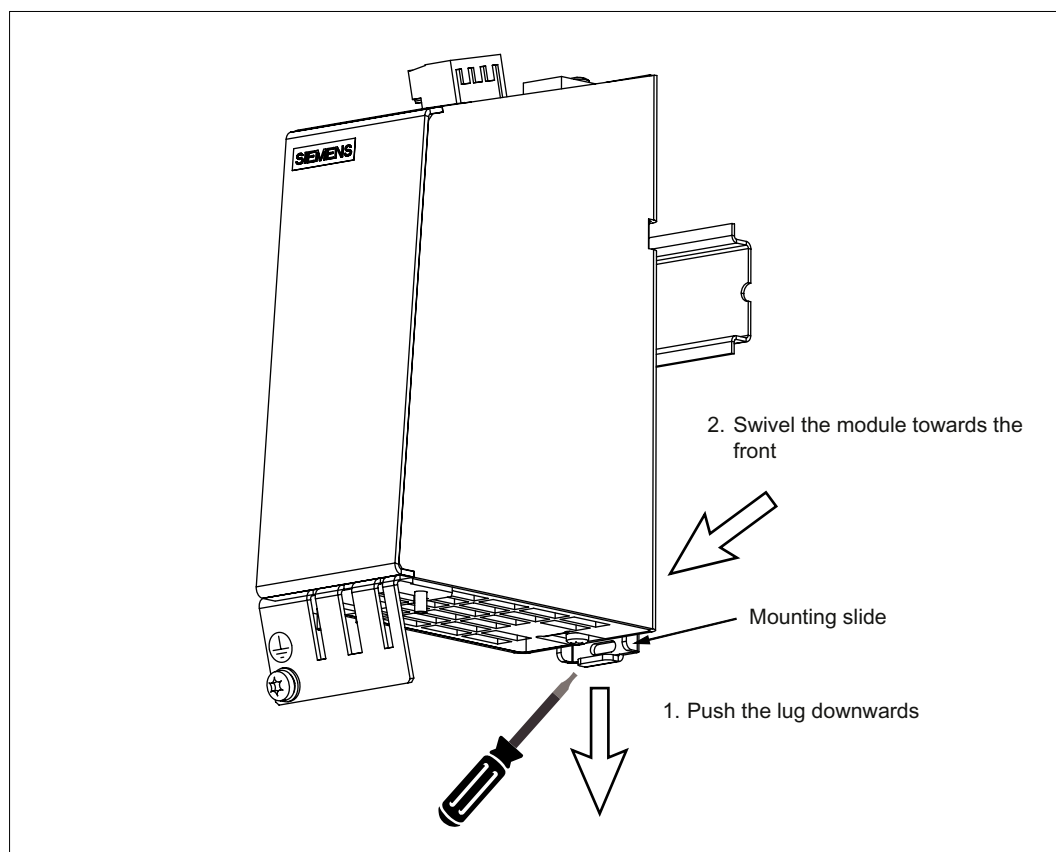

Figure 3-51 Removal of a component from a DIN rail

3.11.6 Technical data

Table 3- 76 Technical data of the DMC20

6SL3055-0AA00-6AAx	Unit	Value
Electronics power supply		
Voltage	V_{DC}	24 DC (20.4 – 28.8)
Current (without DRIVE-CLiQ consumer)	A_{DC}	0.15
PE/ground connection	At the housing with M4/1.8 Nm stud	
Weight	kg	0.8

3.12 DRIVE-CLiQ Hub Module External DME20

3.12.1 Description

The DRIVE-CLiQ Hub Module External DME20 is used to implement star-shaped distribution of a DRIVE-CLiQ line. With the DME20, an axis grouping can be expanded with 5 DRIVE-CLiQ sockets for additional subgroups.

The component has degree of protection IP67 and is especially suitable for applications which require DRIVE-CLiQ nodes to be removed in groups, without interrupting the DRIVE-CLiQ line and therefore the data exchange.

The DME20 can be used with firmware version 2.6 or higher.

3.12.2 Safety information

NOTICE
In order to guarantee degree of protection IP67, all of the plug connectors must be correctly screwed into place and appropriately locked.

NOTICE
The unused DRIVE-CLiQ interfaces must be closed using a protective cap that is included in the scope of delivery.

Note

All components operated on the DRIVE-CLiQ must be integrated into the equipotential bonding concept.

They should preferably be connected by installing them on bright machine parts and devices, which are all bonded to one another in an equipotential manner.

Alternatively, equipotential bonding can be achieved by means of a conductor (min. 6 mm²), which should be routed parallel to the DRIVE-CLiQ where possible. This applies to all distributed DRIVE-CLiQ nodes such as DM20, SME2x, SM12x, etc.

For the DME20 this also applies to the 24 V power supply.

3.12.3 Interface description

3.12.3.1 Overview

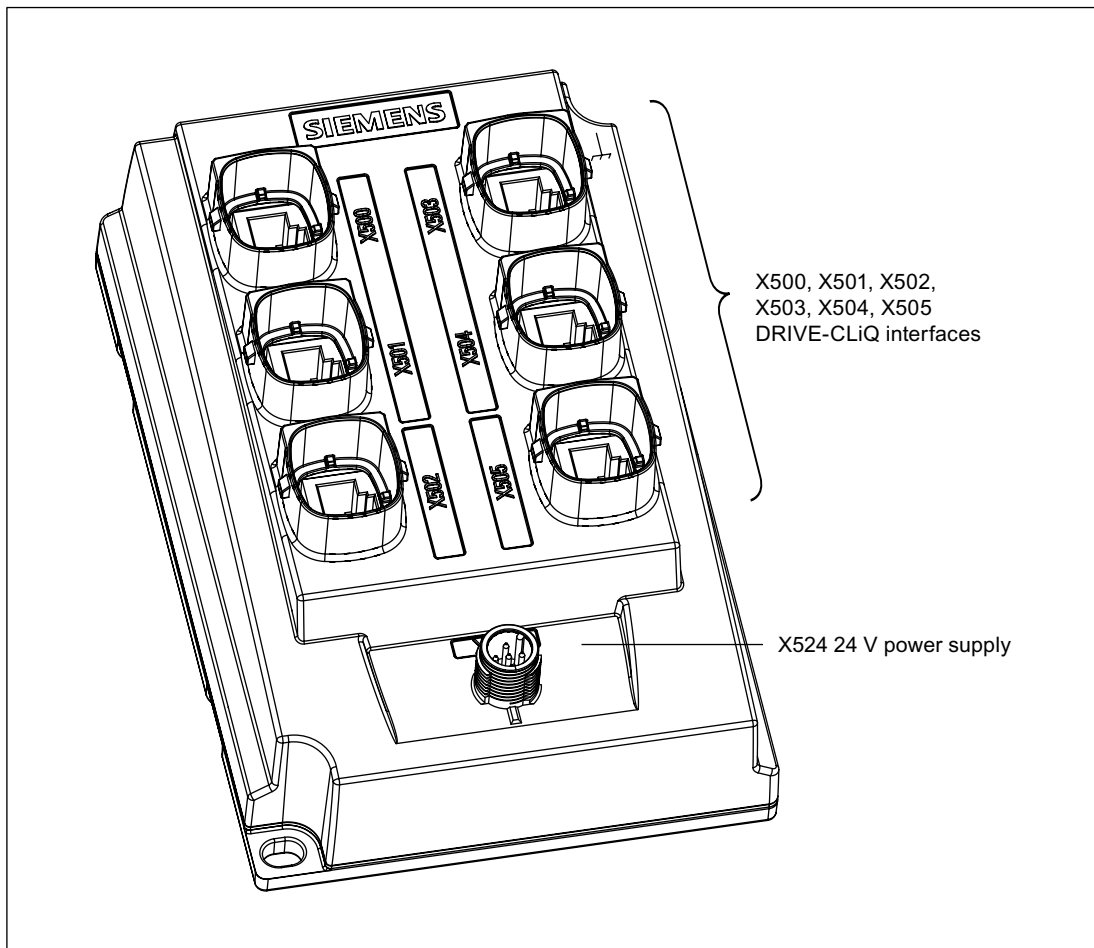
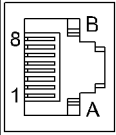

Figure 3-52 Interface description of the DME20

3.12.3.2 X500 - X505 DRIVE-CLiQ interfaces

Table 3- 77 DRIVE-CLiQ interfaces X500 - X505

	Pin	Signal name	Technical specifications	
	1	TXP	Transmit data +	
	2	TXN	Transmit data -	
	3	RXP	Receive data +	
	4	Reserved, do not use		
	5	Reserved, do not use		
	6	RXN	Receive data -	
	7	Reserved, do not use		
	8	Reserved, do not use		
	A	+ (24 V)	Power supply	
	B	M (0 V)	Electronics ground	
	Connector type: RJ45 socket; blanking plate for DRIVE-CLiQ interfaces included in the scope of delivery; blanking plate (50 pieces) order number: 6SL3066-4CA00-0AA0			

Note

Only MOTION-CONNECT DRIVE-CLiQ cables may be used to establish connections. The maximum length of MOTION-CONNECT 500 cables is 100 m and of MOTION-CONNECT 800 cables 50 m.

3.12.3.3 X524 Electronics power supply

Table 3- 78 X524 socket for the electronics power supply

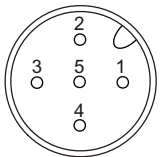
	Pin	Designation	Technical specifications
	1	Electronics power supply	The connection voltage of 20.4 V – 28.8 V refers to the (terminal) voltage at the DME20. This must be taken into account when selecting the cable cross-section and supply cable lengths. Pins 1 and 2: jumpered internally Pins 3 and 4: jumpered internally
	2	Electronics power supply	
	3	Electronics ground	
	4	Electronics ground	
	5	not connected	
Max. connectable cross-section: 4 x 0.75 mm ² e.g. 5-pole shielded connector, user-assembled: Phoenix company, Order No.: 1508365, 4-pole non-shielded connector, user-assembled, Speedcon quick-lock: Phoenix company, Order No. 1521601			

Note

The maximum cable length for the P24 supply of the DME20 is 100 m.

Table 3- 79 Cable length of P24 supply cable:

connected loads ¹⁾	1	2	3	4	5
Cross section					
0.34 mm ²	75 m	45 m	30 m	25 m	20 m
2 x 0.34 mm ²	100 m	90 m	65 m	50 m	40 m
0.75 mm ²	100 m	100 m	75 m	60 m	50 m
2 x 0.75 mm ²	100 m	100 m	100 m	100 m	100 m
¹⁾ Connected motors with DRIVE-CLiQ encoder, DRIVE CLiQ mounted encoder SME Ta = 55 °C 100 m DRIVE-CLiQ					

3.12.4 Dimension drawing

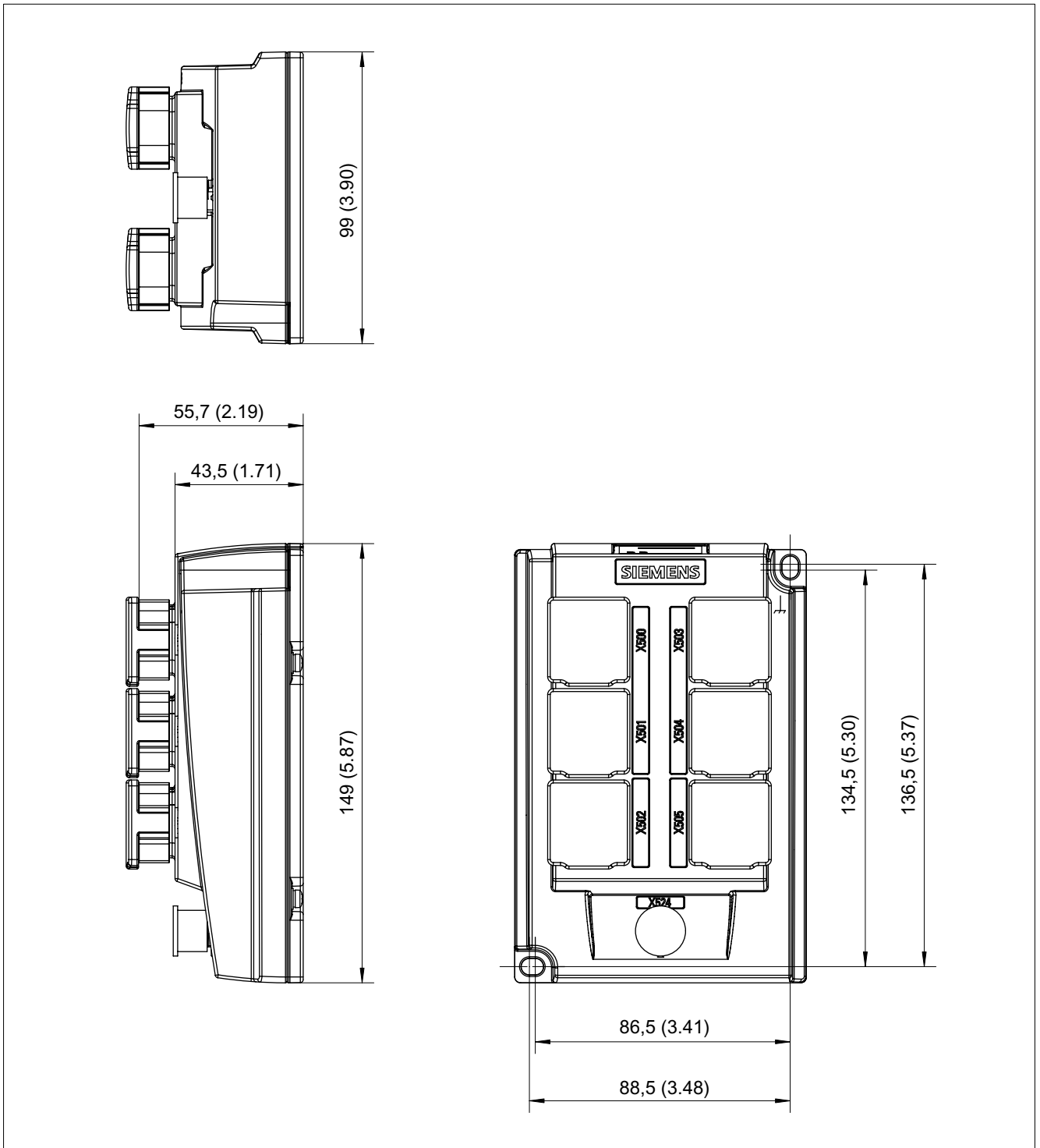

Figure 3-53 Dimension drawing of the DRIVE-CLiQ Hub Module External DME20, all data in mm and (inches)

3.12.5 Installation

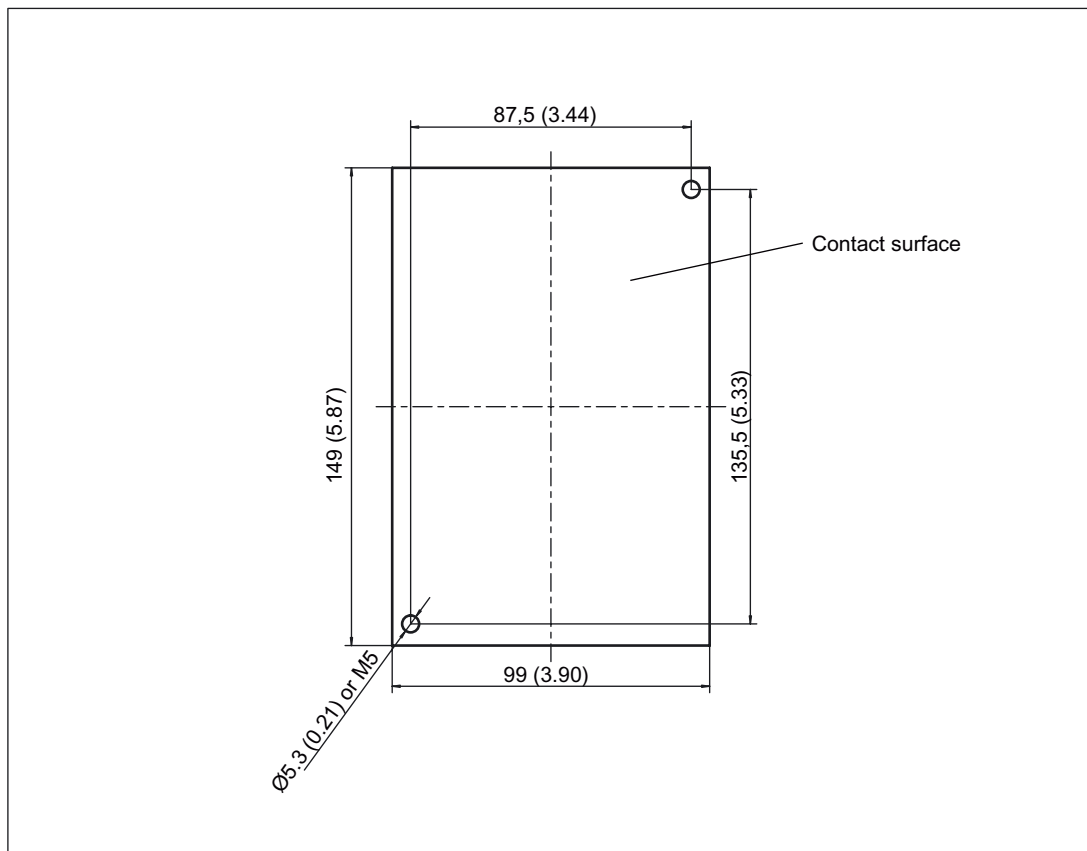

Figure 3-54 DME20 installation

Installation

1. Place the hole drilling template on the contact surface.
2. The contact surfaces must be unpainted metal.
3. Holes Ø5.3 or threads M5
4. Tighten with a tightening torque of 6.0 Nm.

3.12.6 Technical data

Table 3- 80 Technical data of the DME20

6SL3055-0AA00-6ABx	Unit	Value
Electronics power supply		
Voltage	V _{DC}	24 DC (20.4 – 28.8)
Current (without DRIVE-CLiQ node)	A _{DC}	0.15
PE/ground connection	Fastened to housing M5 / 6 Nm	
Degree of protection	IP67	
Weight	kg	0.8

3.12.7 Specifications for use with UL approval

Pre-assembled cables

Sensor/actuator cable, 5-pin, variable cable,
free cable end at straight socket M12-SPEEDCON,
cable length: 2, 5, 10, 15 m
SAC-5P-xxx-186/FS SCO
Up to 100 m on request

Phoenix Contact, www.phoenixcontact.com

Cables to be assembled by the user

Cable	Connector
Cable coil, black PUR/PVC, 5-pin Conductor colors: brown/white/blue/black/gray Cable length: 100 m SAC-5P-100.0-186/0.75 Order number: 1535590	Sensor/actuator connector, socket, straight, 5-pin, M12, A-coded Screw connection, metal knurl, cable gland Pg9 SACC-M12FS-5CON-PG9-M Order number: 1681486
Phoenix Contact, www.phoenixcontact.com	

Power supply

The DME20 must be connected to a 24 V power supply with voltage limitation.

- SITOP 6EP1x.. or 6ES7307..
- SINAMICS Control Supply Module 6SL3100-1DE22-0Axx

Pin assignment of the cable

Table 3- 81 Connection to X524 electronics power supply

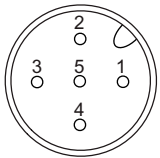
	Pin	Designation	Technical specifications
	1 (brown) ¹⁾	Electronics power supply	The connection voltage of 20.4 V – 28.8 V refers to the (terminal) voltage at the DME20. This must be taken into account when selecting the cable cross-section and supply cable lengths. Pins 1 and 2: jumpered internally Pins 3 and 4: jumpered internally
	2 (white) ¹⁾	Electronics power supply	
	3 (black) ¹⁾	Electronics ground	
	4 (blue) ¹⁾	Electronics ground	
	5 (gray) ¹⁾	Not connected internally	

1) The colors stated refer to the cable specified above

3.13 Voltage Sensing Module VSM10

3.13.1 Description

The Voltage Sensing Module VSM10 is a voltage sensing module that is used to sense the actual value for Active Line Modules and Smart Line Modules from 16 kW and upwards. The Voltage Sensing Module is used to sense the three-phase line supply voltage upstream of the line reactor, which is then provided to the corresponding infeed control ¹⁾.

For booksize units, these components can be optionally used to increase the degree of ruggedness against irregularities in the line supply.

In addition to the voltage sensing, a temperature sensor can be connector to the VSM10 to thermally monitor the line reactor. Further, the functionality of the line filter can checked using two analog inputs.

The VSM10 can be used with firmware version 2.4 or higher.

1) The infeed control is a firmware function that is required for the open-loop and closed-loop control, monitoring, and communication of an infeed.

Table 3- 82 Interface overview of the VSM10

Type	Quantity
Analog inputs	2
Line supply voltage connections (690 V)	3
Line supply voltage connections (100 V)	3
Temperature sensor input	1

3.13.2 Safety information

 WARNING
The ventilation spaces of 50 mm above and below the component must be observed.

NOTICE
The VSM10 has two terminal strips to sense the three-phase line supply voltage (X521 and X522). The voltage strength of terminal X521 is a maximum of 100 V (phase-to-phase) and is used for voltage sensing via a potential transformer. A maximum voltage to be sensed of up to 690 V (phase-to-phase) can be directly connected to terminal X522. Only one of the two terminals X521 and X522 may be used. Nothing may be connected to the unused terminal.

 CAUTION
Connecting cables to temperature sensors must always be installed with shielding. The cable shield must be connected to the ground potential at both ends over a large surface area. Temperature sensor cables that are routed together with the motor cable must be twisted in pairs and shielded separately.

3.13.3 Interface description

3.13.3.1 Overview

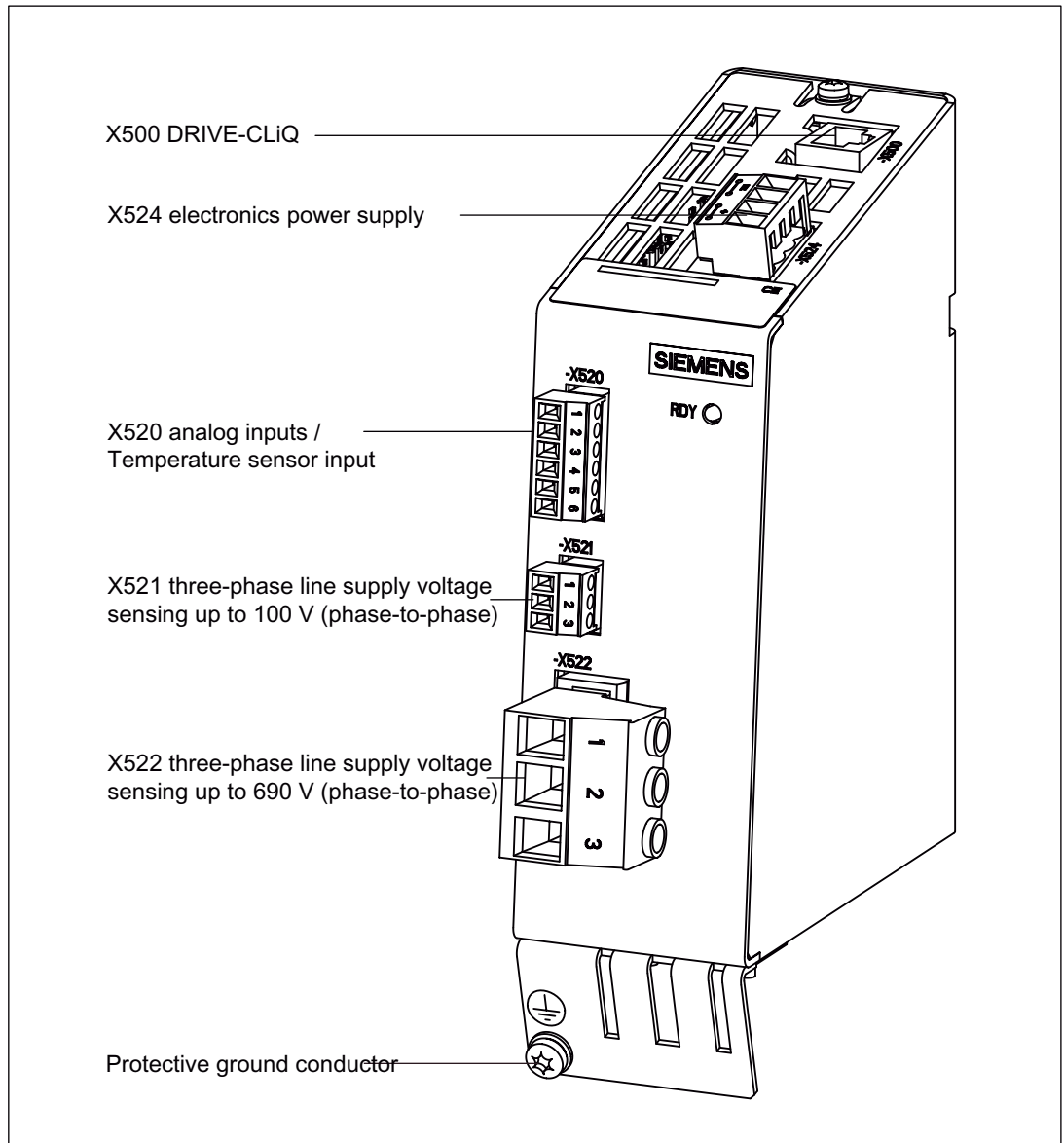

Figure 3-55 Interface description of the VSM10

3.13.3.2 Connection example

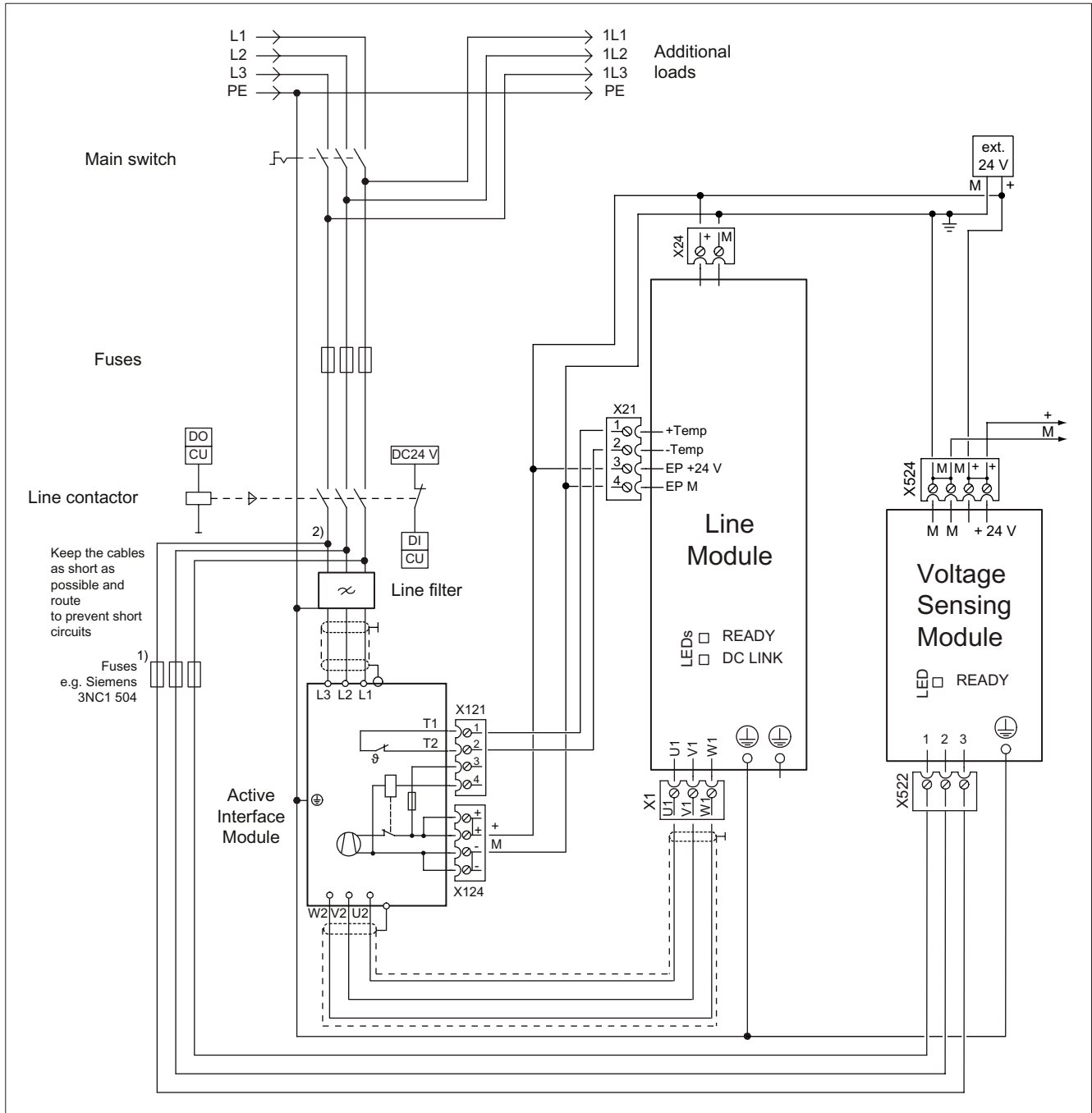

Figure 3-56 Connection example, VSM10

- 1) It is only possible to omit the fuses if the cables to the Voltage Sensing Module are laid according to EN 60439-1 so that no short-circuit or ground fault can be expected under normal operating conditions (short-circuit-proof installation).
- 2) The line supply voltage is tapped as an actual value for the Voltage Sensing Module VSM10 in accordance with the system design; for examples see the table.

Table 3- 83 Suggestions for terminals and cable lugs which can be used to connect a VSM10 to the line

Conductor cross-section	VSM connection	Example components
Up to 6 mm ²	Direct connection possible	Smart Line Modules 5 kW and 10 kW
6 mm ² to 16 mm ²	ST16-TWIN terminal blocks, if required with a reducing comb and ST4-TWIN or ST2.5-TWIN Phoenix Contact	Active Line Modules 16 kW Smart Line Modules 16 kW Active Interface Module 16 kW
16 mm ² to 50 mm ²	AGK10 UKH tap-off terminals with UKH terminals Phoenix Contact	Active Line Modules 36 kW and 55 kW Smart Line Modules 36 kW Active Interface Module 36 kW and 55 kW
> 50 mm ²	Ring cable lug DIN 46234-8-2.5	Components with M8 connection bolt Active Line Modules 55 kW, 80 kW, and 100 kW Active Interface Module 80 kW and 100 kW
	Intermediate high-current connector, type UHV (Phoenix Contact) and ring cable lug DIN 46234-8-2.5	

3.13.3.3 X500 DRIVE-CLiQ interface

Table 3- 84 X500 DRIVE-CLiQ interface

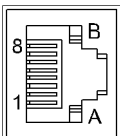
	Pin	Signal name	Technical specifications
	1	TXP	Transmit data +
	2	TXN	Transmit data -
	3	RXP	Receive data +
	4	Reserved, do not use	
	5	Reserved, do not use	
	6	RXN	Receive data -
	7	Reserved, do not use	
	8	Reserved, do not use	
	A	+ (24 V)	Power supply
	B	M (0 V)	Electronics ground
Blanking plate for DRIVE-CLiQ interface included in the scope of delivery; blanking plate (50 pieces) order number: 6SL3066-4CA00-0AA0			

Note

The maximum connectable DRIVE-CLiQ cable length is 50 m.

3.13.3.4 X524 Electronics power supply

Table 3- 85 Terminals for the electronics power supply

	Terminal	Designation	Technical specifications
	+	Electronics power supply	Voltage: 24 V DC (20.4 V – 28.8 V) Current consumption: max. 0.2 A
	+	Electronics power supply	
	M	Electronics ground	Max. current via jumper in connector: 20 A
	M	Electronics ground	
Max. connectable cross-section: 2.5 mm ² Type: Screw terminal 2 (see Appendix A) The maximum cable length that can be connected is 10 m.			

Note

The two "+" and "M" terminals are jumpered in the connector. This ensures that the supply voltage is looped through.

3.13.3.5 X520 analog inputs/temperature sensor

Table 3- 86 Terminal block X520

	Terminal	Designation	Technical specifications
	1	AI 0+	2 analog differential inputs +/- 10V to monitor the line filter resonance Resolution: 12 bits
	2	AI 0-	
	3	AI 1+	
	4	AI 1-	
	5	+ Temp	Temperature sensor KTY84-1C130 / PTC
	6	- Temp	
Max. connectable cross-section: 1.5 mm ² Type: Screw terminal 1 (see Appendix A)			

Note

In order to minimize noise emission, shielded cables should be used.

CAUTION

The common mode range may not be violated. This means that the analog differential voltage signals can have a maximum offset voltage of +/-30 V with respect to the ground potential. If the range is infringed, incorrect results may occur during analog/digital conversion.

3.13.3.6 X521 three-phase line supply voltage sensing up to 100 V (phase-to-phase)

This interface is not relevant for booksize units.

3.13.3.7 X522 three-phase line supply voltage sensing up to 690 V (phase-to-phase)

Table 3- 87 Terminal block X522

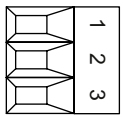
	Terminal	Designation	Technical specifications
	1	Phase voltage U	Directly connected to sense the line supply voltage
	2	Phase voltage V	
	3	Phase voltage W	
Max. connectable cross-section: 6 mm ² Type: Screw terminal 5 (see Appendix A)			

NOTICE
Only one of the two terminals X521 and X522 may be used. Nothing may be connected to the unused terminal.

NOTICE
The line phases must be connected to the VSM10 with the same sequence as that of the Line Module. If this is not observed, when the Line Module is enabled, overcurrents can occur.

NOTICE
If the configuration has a line filter, then the phase voltages for the VSM (X522) must be taken from in front of the line filter. If the configuration does not have a line filter, then X522 must be connected to the line side of the line reactor (voltages are taken from in front of the line reactor).

3.13.3.8 Meanings of the LEDs on the Voltage Sensing Module VSM10

Table 3- 88 Voltage Sensing Module VSM10 – description of LEDs

LED	Color	State	Description, cause	Remedy
READY	-	OFF	Electronics power supply is missing or outside permissible tolerance range.	-
	Green	Continuous	The component is ready for operation and cyclic DRIVE-CLiQ communication is taking place.	-
	Orange	Continuous	DRIVE-CLiQ communication is being established.	-
	Red	Continuous	At least one fault is present in this component. Note: The LED is activated regardless of whether the corresponding messages have been reconfigured.	Remedy and acknowledge fault
	Green/red	Flashing 0.5 Hz	Firmware is being downloaded.	-
		Flashing 2 Hz	Firmware download is complete. Wait for POWER ON	Carry out a POWER ON
Green/ orange or Red/ orange	Flashing	Component recognition via LED is activated (p0144) Note: Both options depend on the LED status when component recognition is activated via p0144 = 1.	-	

Cause and rectification of faults

The following reference contains information about the cause of faults and how they can be rectified:

/IH1/ SINAMICS S120 Commissioning Manual

/LH1/ SINAMICS S List Manual

3.13.4 Dimension drawing

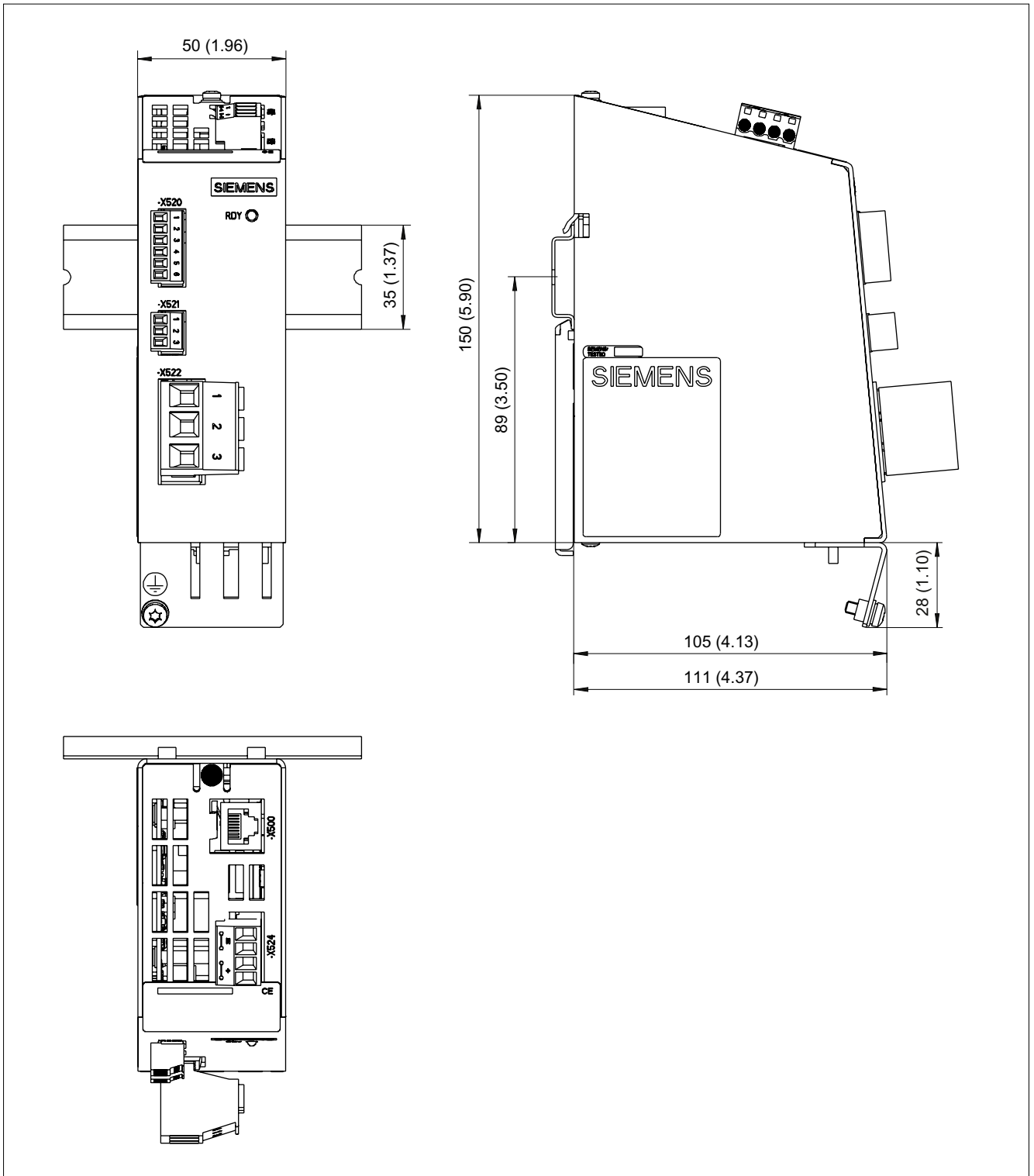

Figure 3-57 Dimension drawing of the Voltage Sensing Module VSM10, all data in mm and (inches)

3.13.5 Protective conductor connection and shield support

The following figure shows typical Weidmüller shield connection clamps for the shield supports.

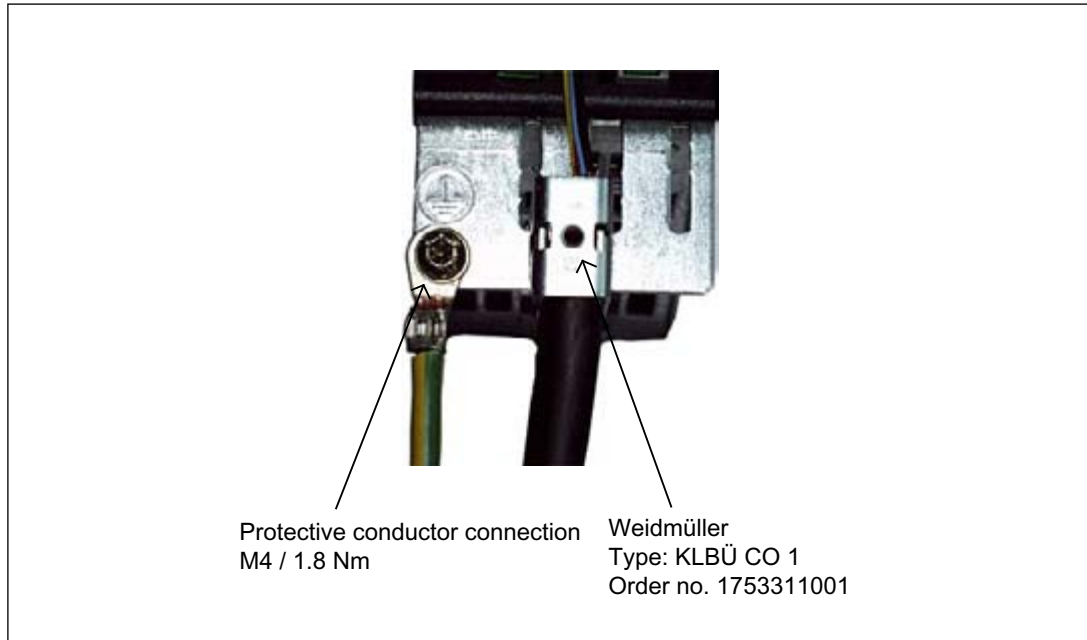

Figure 3-58 Shield contacts

Weidmüller website address: <http://www.weidmueller.com>

⚠ DANGER

If the shielding procedures described and the specified cable lengths are not observed, the machine may not operate properly.

NOTICE

Only use screws with a permissible mounting depth of 4 - 6 mm.

3.13.6 Technical data

Table 3- 89 Technical data

6SL3053-0AA00-3AAx	Unit	Value
Electronics power supply		
Voltage	V _{DC}	24 DC (20.4 – 28.8)
Current (without DRIVE-CLiQ or digital outputs)	A _{DC}	0.3
Power loss	W	<10
PE/ground connection	On the housing with M4, 1.8 Nm screw	
Weight	kg	1

Encoder system connection

4.1 Introduction

The encoder system should be connected to SINAMICS S120 via DRIVE-CLiQ.

Motors with DRIVE-CLiQ interfaces (e.g. synchronous motors 1FK7 and 1FT6, and induction motors 1PH7) are designed for this purpose. These motors simplify commissioning and diagnostics because the motor and encoder type are identified automatically.

Motors and external encoders without DRIVE-CLiQ interface

Motors without DRIVE-CLiQ interfaces, as well as external encoders, must be connected via Sensor Modules to enable the encoder and temperature signals to be evaluated. Sensor Modules Cabinet-Mounted (SMC) are available for installation in control cabinets and Sensor Modules External (SME) for installation outside control cabinets.

If not otherwise specified, only one encoder system can be connected to each Sensor Module.

Motors and external encoders with DRIVE-CLiQ interface

Motors with DRIVE-CLiQ interfaces can be connected to the associated Motor Module directly via the MOTION-CONNECT DRIVE-CLiQ cables available. The connection of the MOTION-CONNECT DRIVE-CLiQ cable at the motor has degree of protection IP67.

The DRIVE-CLiQ interface supplies the motor encoder via the integrated 24 VDC supply and transfers the motor encoder and temperature signals and the electronic rating plate data, e.g. a unique identification number, rated data (voltage, current, torque, etc.) directly to the Control Unit. Different encoder cables are therefore no longer required for the various encoder types, e.g. resolvers or absolute encoders. Wiring can be effected throughout with a MOTION-CONNECT DRIVE-CLiQ cable.

DRIVE-CLiQ encoder

The DRIVE-CLiQ encoder is an absolute encoder with integrated DRIVE-CLiQ interface (see the section titled "DRIVE-CLiQ encoder").

4.2 Overview of Sensor Modules

Sensor Modules Cabinet-Mounted (SMC)

Sensor Modules Cabinet-Mounted can be ordered and configured separately. They are used when a motor with a DRIVE-CLiQ interface is not available or when external encoders in addition to the motor encoder are required. Only one encoder system can be connected to each Sensor Module Cabinet-Mounted. The SMCs evaluate these measuring systems and convert the calculated values to DRIVE-CLiQ. Neither motor nor encoder data are saved.

Note

The SMC supplies the power to the encoder; the SMC, however, must be provided separately with 24 VDC power.

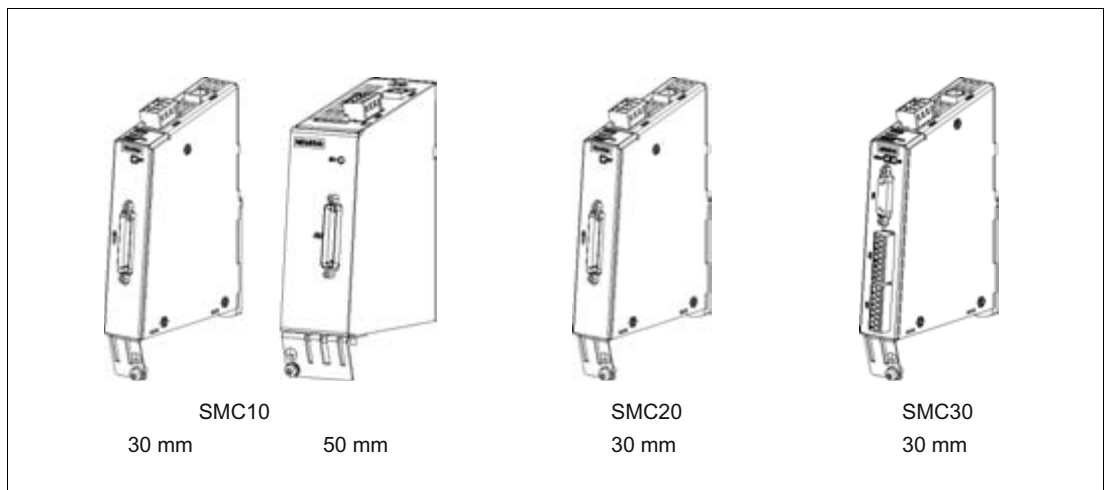

Figure 4-1 Overview of Sensor Modules Cabinet-Mounted (SMC)

Sensor Modules External (SME)

The Sensor Modules SME20, SME25, SME120, and SME125 are only intended for use on machines (in North America, in accordance with the NFPA 79 "Electrical Standard for Industrial Machinery") and may only be connected to the DRIVE-CLiQ interfaces of proprietary components.

Direct encoder systems outside the cabinet can be connected to the Sensor Modules External. The SMEs evaluate these encoder systems and convert the calculated values to DRIVE-CLiQ. No motor or encoder data is stored in the SMEs.

Note

The SME provides the encoder power supply. The power supply for the SME is provided from the connected DRIVE-CLiQ cable. This must be taken into consideration when the DRIVE-CLiQ cable is selected.

The Sensor Modules External have a higher degree of protection (IP67) and are therefore suitable for installation outside the cabinet.

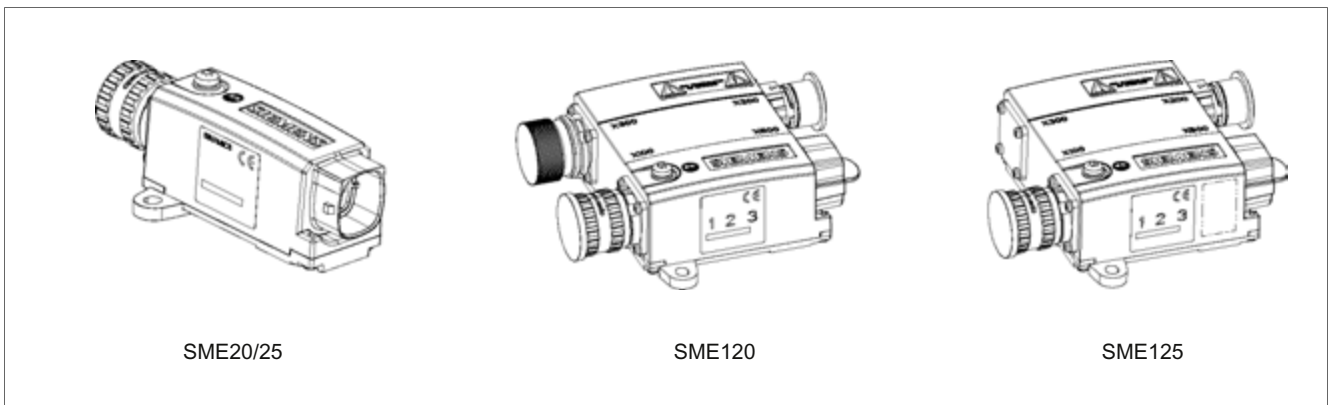

Figure 4-2 Overview of Sensor Modules External (SME)

Connectable encoder systems

Table 4- 1 Connectable encoder systems

Encoder systems	SMC				SME			
	SMC10 30 mm	SMC10 50 mm	SMC20 30 mm	SMC30 30 mm	SME20	SME25	SME120	SME125
Resolver	Yes	Yes	-	-	-	-	-	-
Incremental encoder sin/cos (1 Vpp) with/without reference signal	-	-	Yes	-	Yes	-	Yes	-
Absolute encoder EnDat 2.1	-	-	Yes	-	-	Yes	-	Yes
Incremental encoder TTL / HTL	-	-	-	Yes	-	-	-	-
Absolute encoder SSI	-	-	Yes ¹⁾	Yes ²⁾	-	Yes ¹⁾	-	Yes ¹⁾
Temperature evaluation	Yes	Yes	Yes	Yes	Yes ³⁾	-	Yes (electrically isolated)	Yes (electrically isolated)

1) Only possible for SSI encoders with 5 V supply

2) Possible for SSI encoders with 5 V or 24 V supply

3) With prescribed adapter cable 6FX8002-2CA88

4.3 Sensor Module Cabinet-Mounted SMC10

4.3.1 Description

The Sensor Module Cabinet-Mounted SMC10 evaluates encoder signals and transmits the speed, actual position value, rotor position and, if necessary, the motor temperature via DRIVE-CLiQ to the Control Unit.

The SMC10 is used to evaluate sensor signals from resolvers.

4.3.2 Safety information

 WARNING
The ventilation spaces of 50 mm above and below the component must be observed.

NOTICE
Only one encoder system may be connected per Sensor Module.

Note

There must be no electrical connection between the encoder system housing and the signal cables, or the encoder system electronics. If this is not carefully observed, under certain circumstances the system will not be able to reach the required interference immunity level (there is then a danger of equalization currents flowing through the electronics ground).

 CAUTION
Connecting cables to temperature sensors must always be installed with shielding. The cable shield must be connected to the ground potential at both ends over a large surface area. Temperature sensor cables that are routed together with the motor cable must be twisted in pairs and shielded separately.

4.3.3 Interface description

4.3.3.1 Overview

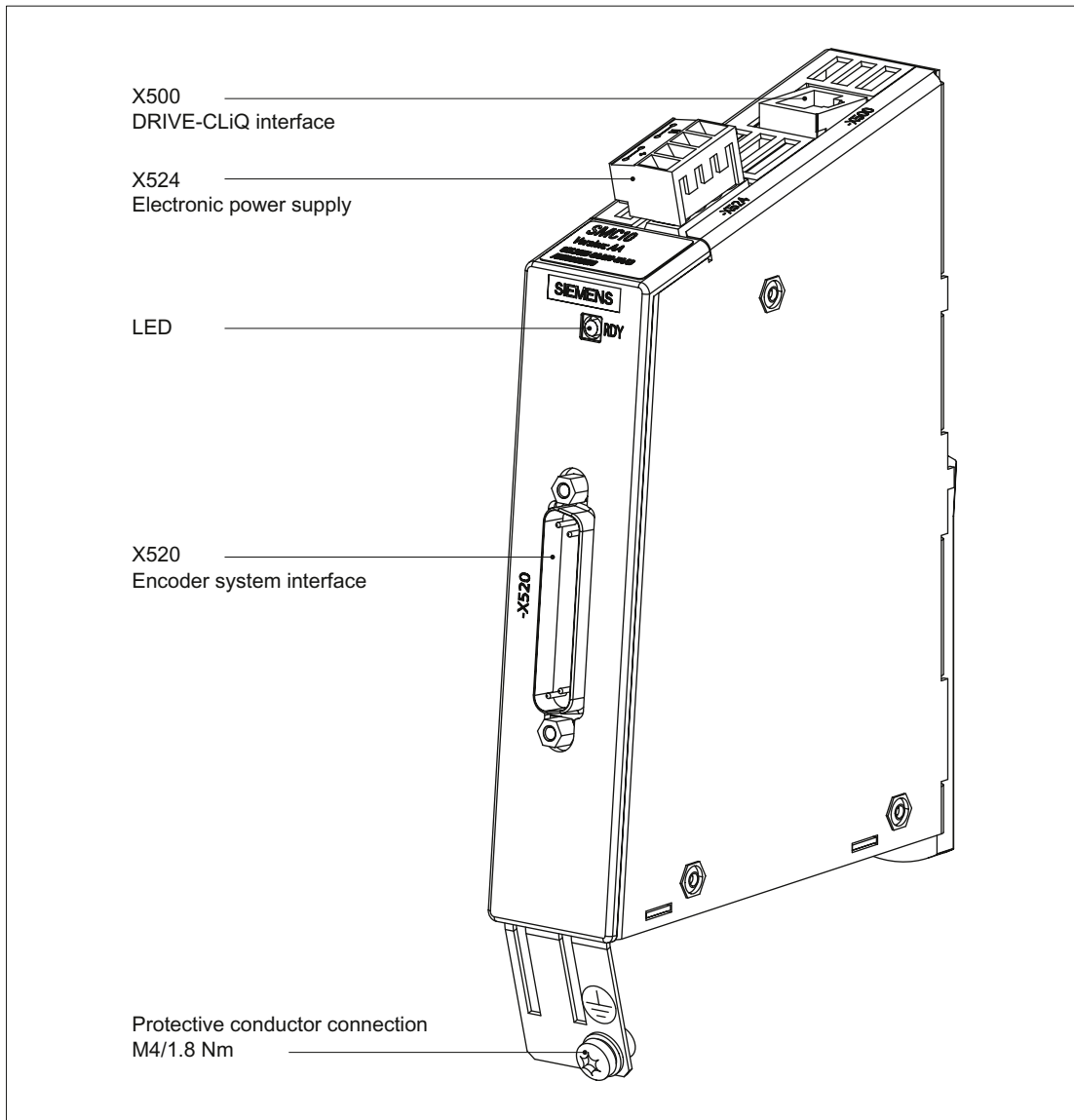

Figure 4-3 Interface description of the SMC10, 30 mm wide, order number: 6SL3055-0AA00-5AA3

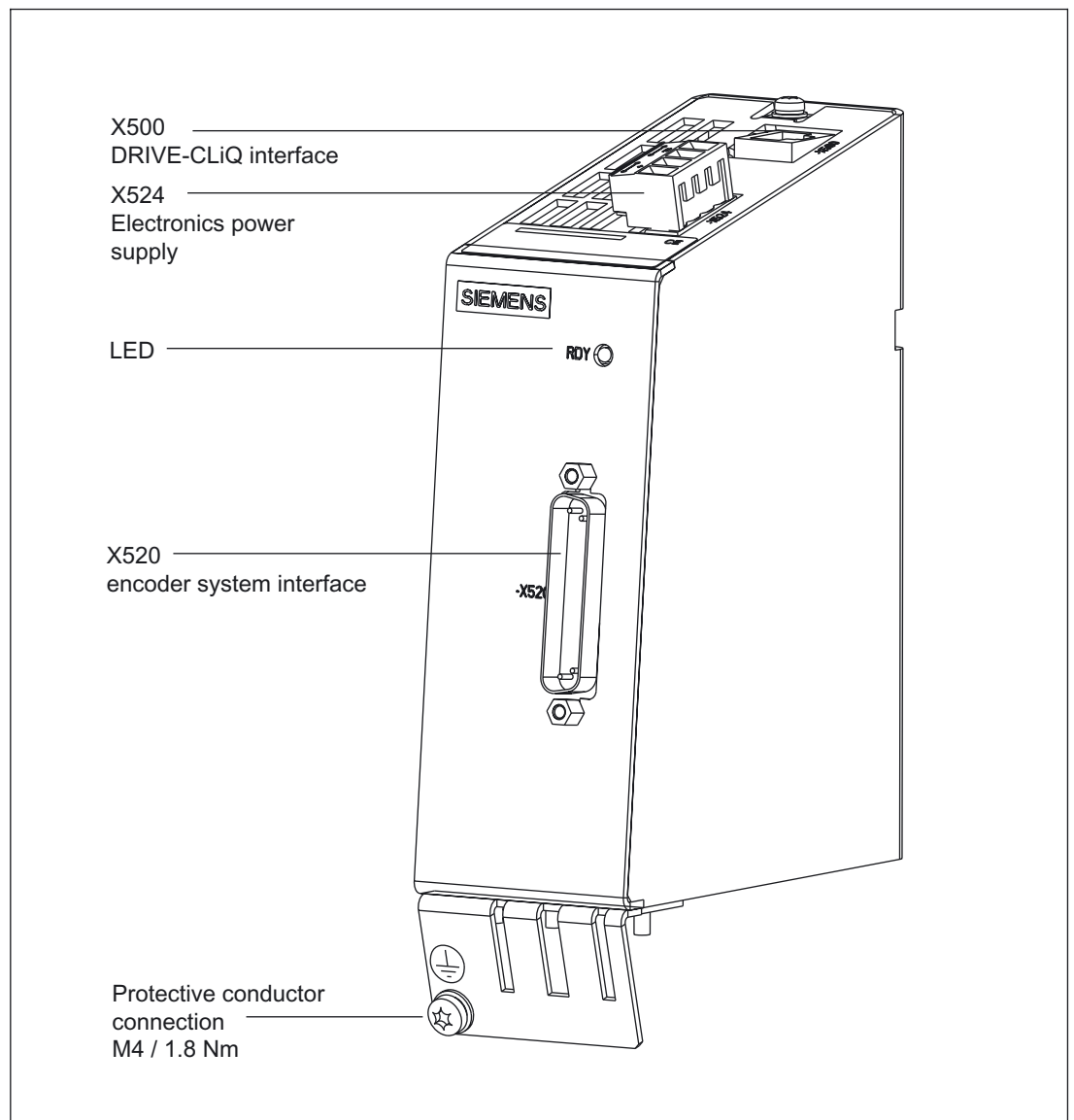

Figure 4-4 Interface description of the SMC10, 50 mm wide,
order number: 6SL3055-0AA00-5AA0

4.3.3.2 Connection example

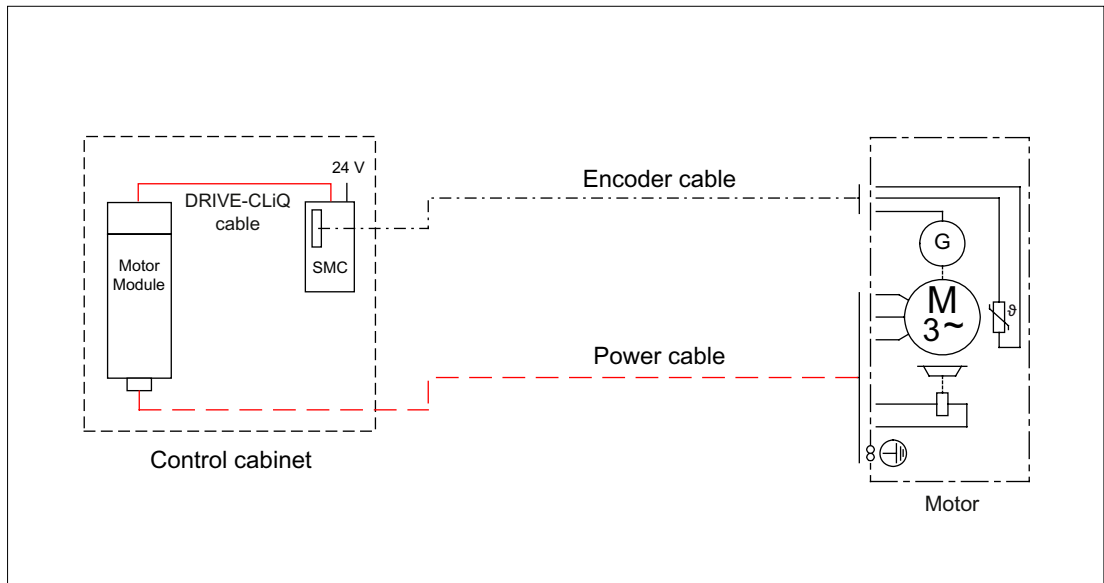

Figure 4-5 Connection of an encoder system via a Sensor Module Cabinet-Mounted (SMC) for a motor without a DRIVE-CLiQ interface

4.3.3.3 DRIVE-CLiQ interface X500

Table 4-2 DRIVE-CLiQ interface X500

	Pin	Signal name	Technical specifications
	1	TXP	Transmit data +
	2	TXN	Transmit data -
	3	RXP	Receive data +
	4	Reserved, do not use	
	5	Reserved, do not use	
	6	RXN	Receive data -
	7	Reserved, do not use	
	8	Reserved, do not use	
	A	Reserved, do not use	
	B	GND (0 V)	Electronics ground

4.3.3.4 X520 encoder system interface

Table 4- 3 X520 encoder system interface

	Pin	Signal name	Technical specifications
	1	Reserved, do not use	
	2	Reserved, do not use	
	3	S2	Resolver signal A (sin+)
	4	S4	Inverse resolver signal A (sin-)
	5	Ground	Ground (for internal shield)
	6	S1	Resolver signal B (cos+)
	7	S3	Inverse resolver signal B (cos-)
	8	Ground	Ground (for internal shield)
	9	R1	Resolver excitation positive
	10	Reserved, do not use	
	11	R2	Resolver excitation negative
	12	Reserved, do not use	
	13	+ Temp	Motor temperature measurement KTY84-1C130 (KTY+) Temperature sensor KTY84-1C130 / PTC
	14	Reserved, do not use	
	15	Reserved, do not use	
	16	Reserved, do not use	
	17	Reserved, do not use	
	18	Reserved, do not use	
	19	Reserved, do not use	
	20	Reserved, do not use	
	21	Reserved, do not use	
	22	Reserved, do not use	
	23	Reserved, do not use	
	24	Ground	Ground (for internal shield)
	25	- Temp	Motor temperature measurement KTY84-1C130 (KTY-) Temperature sensor KTY84-1C130 / PTC

DANGER
<p>Risk of electric shock!</p> <p>Only temperature sensors that meet the safety isolation specifications contained in EN 61800-5-1 may be connected to terminals "+Temp" and "-Temp". If safe electrical separation cannot be guaranteed (for linear motors or third-party motors, for example), a Sensor Module External (SME120 or SME125) or Terminal Module TM120 must be used.</p> <p>If these instructions are not complied with, there is a risk of electric shock!</p>

4.3 Sensor Module Cabinet-Mounted SMC10

4.3.3.5 X524 Electronics power supply

Table 4- 4 X524 terminal block

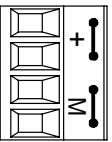
	Terminal	Function	Technical specifications
	+	Electronics power supply	Voltage: 24 V (20.4 V – 28.8 V) Current consumption: Max. 0.35 A Maximum current via jumper in connector: 20 A
	+	Electronics power supply	
	M	Electronics ground	
	M	Electronics ground	
Max. connectable cross-section: 2.5 mm ² Type: Screw terminal 2 (see Appendix)			

Note

The two "+" and "M" terminals are jumpered in the connector. This ensures that the supply voltage is looped through.

4.3.3.6 Meaning of LEDs on the Sensor Module Cabinet-Mounted SMC10

Table 4- 5 Sensor Module Cabinet-Mounted SMC10 – description of the LEDs

LED	Color	Status	Description, cause	Remedy
RDY READY	-	Off	Electronics power supply is missing or outside permissible tolerance range.	-
	Green	Continuous light	The component is ready for operation and cyclic DRIVE-CLiQ communication is taking place.	-
	Orange	Continuous light	DRIVE-CLiQ communication is being established.	-
	Red	Continuous light	At least one fault is present in this component. Note: The LED is activated regardless of whether the corresponding messages have been reconfigured.	Remedy and acknowledge fault
	Green/red	0.5 Hz flashing light	Firmware is being downloaded.	-
		2 Hz flashing light	Firmware download is complete. Wait for POWER ON	Carry out a POWER ON
	Green/ orange or Red/ orange	Flashing light	Component recognition via LED is activated (p0144). Note: Both options depend on the LED status when component recognition is activated via p0144 = 1.	-

Cause and rectification of faults

The following reference contains information about the cause of faults and how they can be rectified:

/IH1/ SINAMICS S120 Commissioning Manual

/LH1/ SINAMICS S List Manual

4.3.4 Dimension drawings

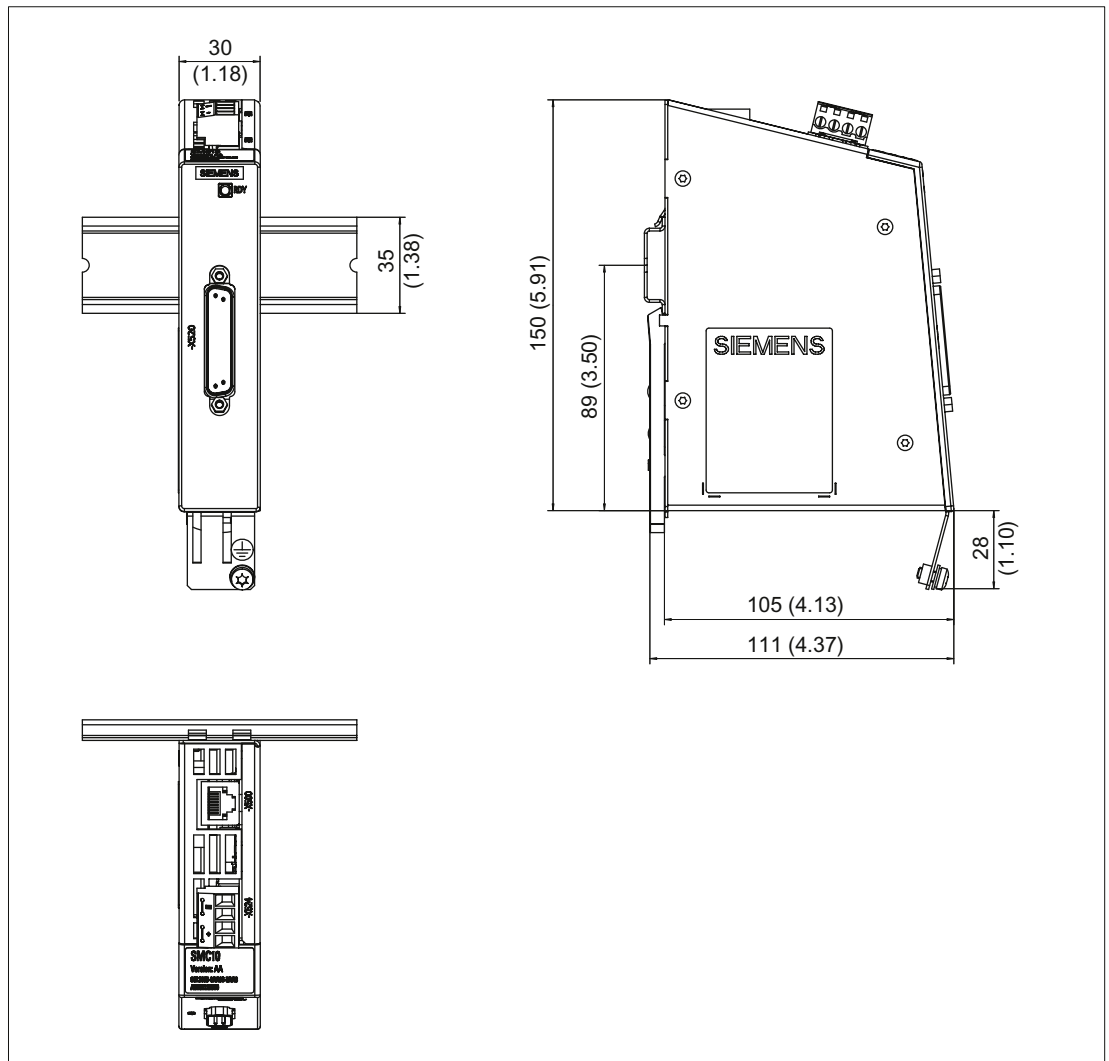

Figure 4-6 Dimension drawing of the Sensor Module Cabinet SMC10, 30 mm wide, all data in mm and (inches); order number: 6SL3055-0AA00-5AA3

4.3 Sensor Module Cabinet-Mounted SMC10

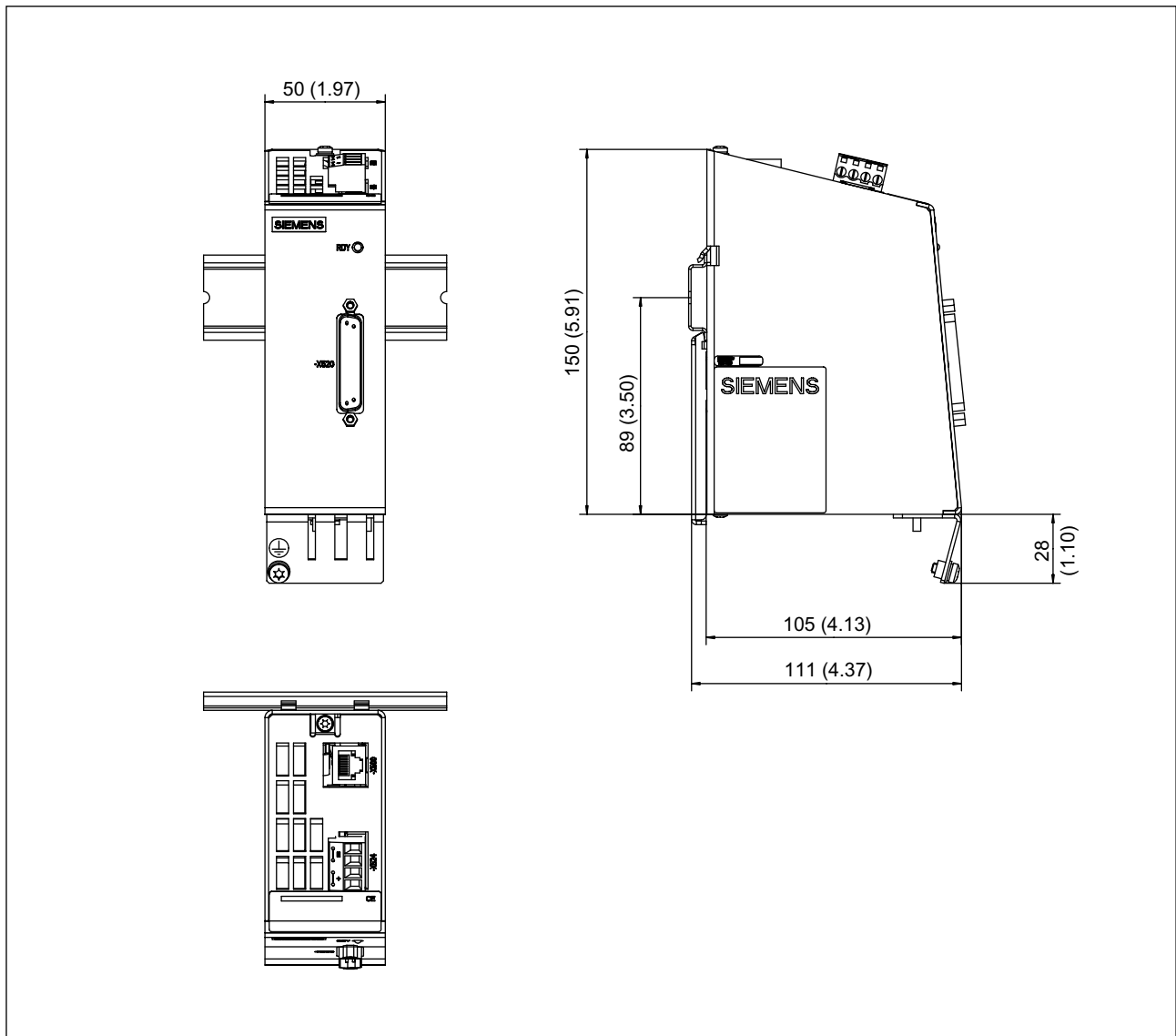

Figure 4-7 Dimension drawing of the Sensor Module Cabinet SMC10, 50 mm wide, all data in mm and (inches); order number: 6SL3055-0AA00-5AA0

4.3.5 Installation

Installation

1. Tilt the component backwards slightly and attach it to the DIN rail using the hook.
2. Push the component towards the DIN rail until you hear the mounting slide at the rear latch into position.
3. You can now move the component to the left or right along the DIN rail, until it reaches its final position.

Removal

1. The lug on the mounting slide first needs to be pushed down to unlock the slide from the DIN rail.
2. The component can now be tilted forwards and pulled up and off the DIN rail.

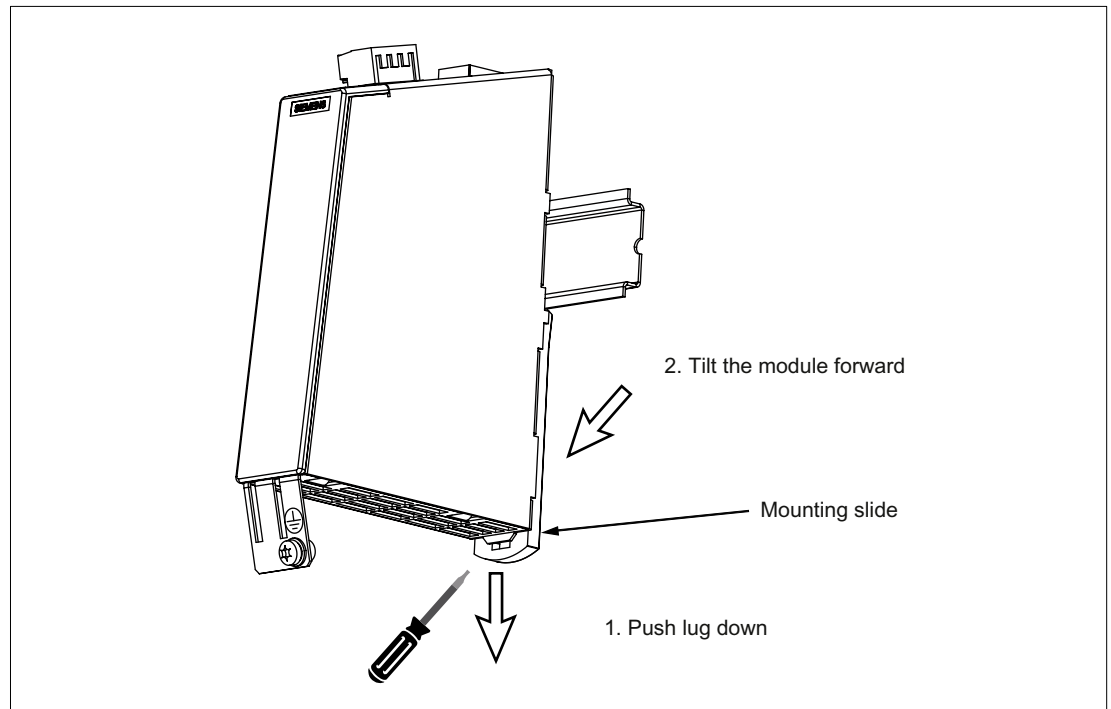

Figure 4-8 Removal of a component from a DIN rail

4.3.6 Technical data

Table 4- 6 Technical data

6SL3055-0AA00-5AAx	Unit	Value
Electronics power supply		
Voltage	V _{DC}	24 DC (20.4 – 28.8)
Current (without encoder system)	A _{DC}	≤ 0.20
Current (with encoder system)	A _{DC}	≤ 0.35
Power loss	W	≤ 10
Specification		
Transformation ratio of the resolver (ü)		0.5
Excitation voltage on the SMC10 when ü=0.5	V _{rms}	4.1
Amplitude monitoring threshold (secondary tracks) of the SMC10	V _{rms}	1
Excitation voltage (cannot be parameterized)	V _{rms}	4.1
Excitation frequency (synchronized to the current controller clock cycle)	kHz	5 to 16 (order number 6SL3055-0AA00-5AA3) 5 to 10 (order number 6SL3055-0AA00-5AA0)
PE/ground connection		On housing with M4/1.8 Nm screw
Max. encoder cable length	m	130
Weight	kg	0.45 (order number 6SL3055-0AA00-5AA3) 0.8 (order number 6SL3055-0AA00-5AA0)
Degree of protection		IP20 or IPXXB

Table 4- 7 Max. frequency that can be evaluated (speed)

Resolver		Max. speed resolver / motor		
Number of poles	Number of pole pairs	8kHz/125 µsec	4kHz/250 µsec	2kHz/500 µsec
2-pole	1	120.000 rpm	60.000 rpm	30.000 rpm
4-pole	2	60.000 rpm	30.000 rpm	15.000 rpm
6-pole	3	40.000 rpm	20.000 rpm	10.000 rpm
8-pole	4	30.000 rpm	15.000 rpm	7.500 rpm

The ratio between the ohmic resistance R and the inductance L (the primary winding of the resolver) determines whether the resolver can be evaluated with the SMC10. See the following diagram:

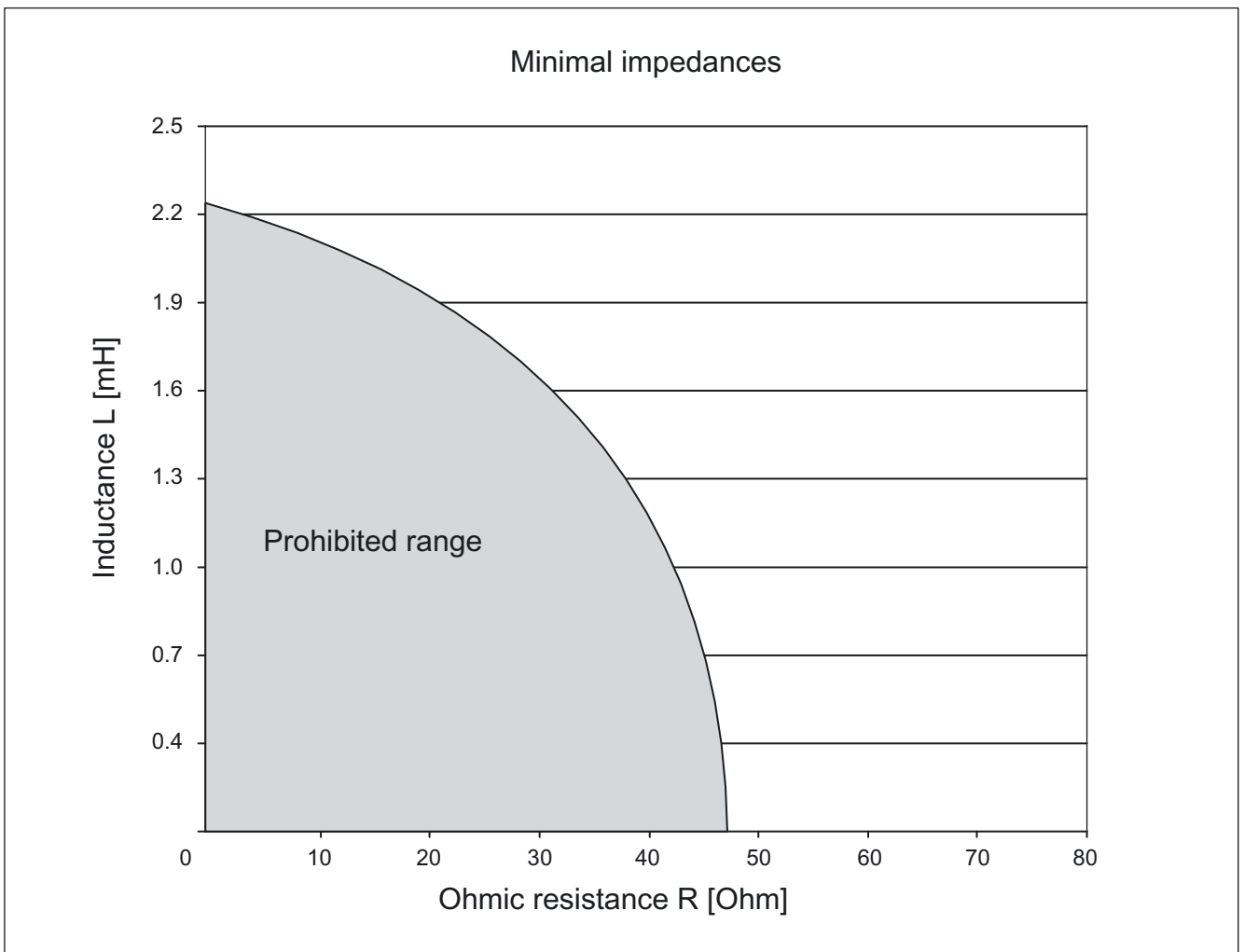

Figure 4-9 Connectable impedances with an excitation frequency $f = 5000$ Hz

4.4 Sensor Module Cabinet-Mounted SMC20

4.4.1 Description

The Sensor Module Cabinet-Mounted SMC20 evaluates encoder signals and transmits the speed, actual position value, rotor position and, if necessary, the motor temperature and reference point via DRIVE-CLiQ to the Control Unit.

The SMC20 is used to evaluate encoder signals from incremental encoders with SIN/COS (1 Vpp) or absolute encoders with EnDat 2.1 or SSI.

4.4.2 Safety information

 WARNING
The ventilation spaces of 50 mm above and below the component must be observed.

NOTICE
Only one encoder system may be connected per Sensor Module.

Note

There must be no electrical connection between the encoder system housing and the signal cables, or the encoder system electronics. If this is not carefully observed, under certain circumstances the system will not be able to reach the required interference immunity level (there is then a danger of equalization currents flowing through the electronics ground).

 CAUTION
Connecting cables to temperature sensors must always be installed with shielding. The cable shield must be connected to the ground potential at both ends over a large surface area. Temperature sensor cables that are routed together with the motor cable must be twisted in pairs and shielded separately.

4.4.3 Interface description

4.4.3.1 Overview

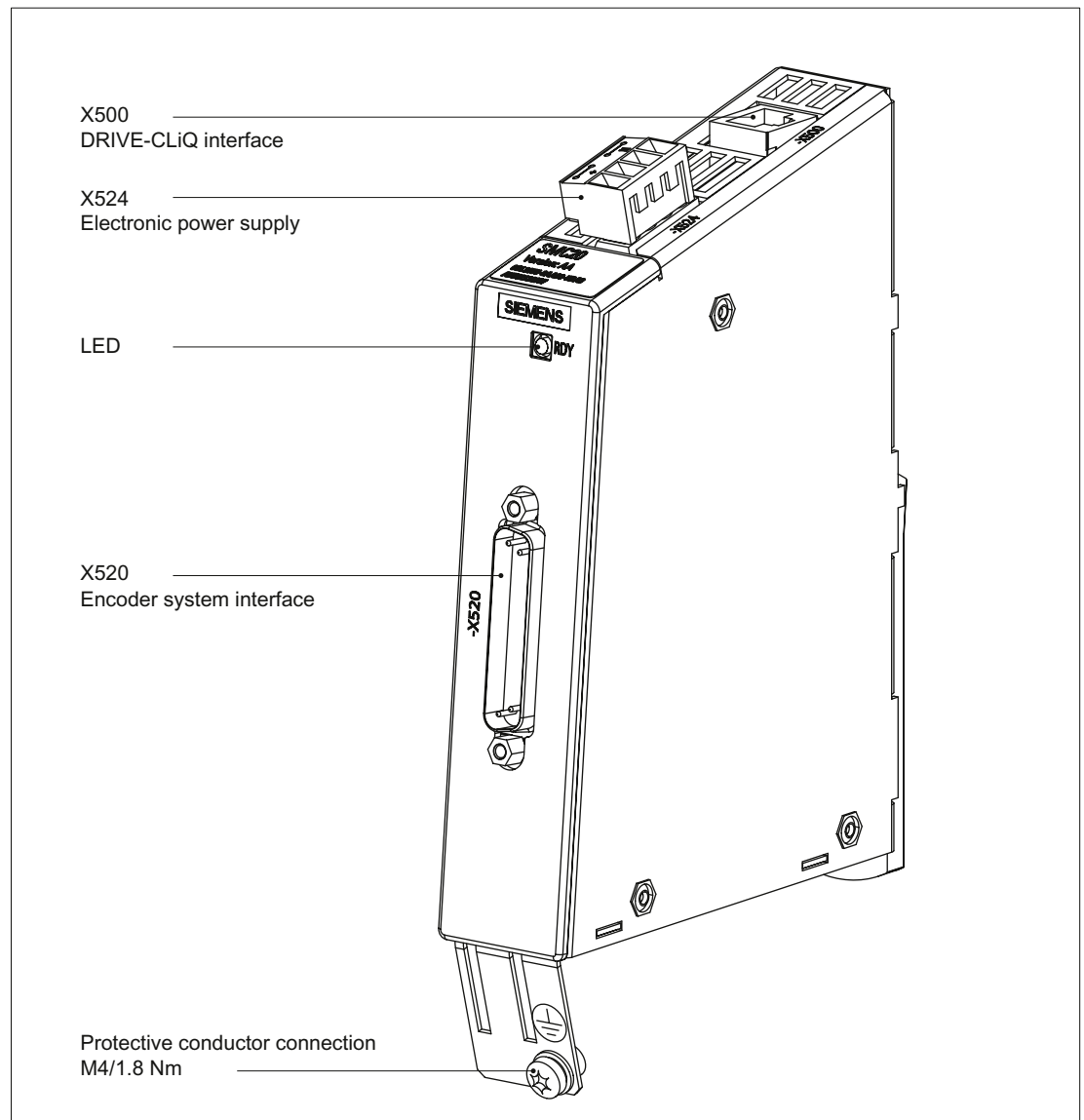

Figure 4-10 Interface description of the SMC20

4.4.3.2 Connection example

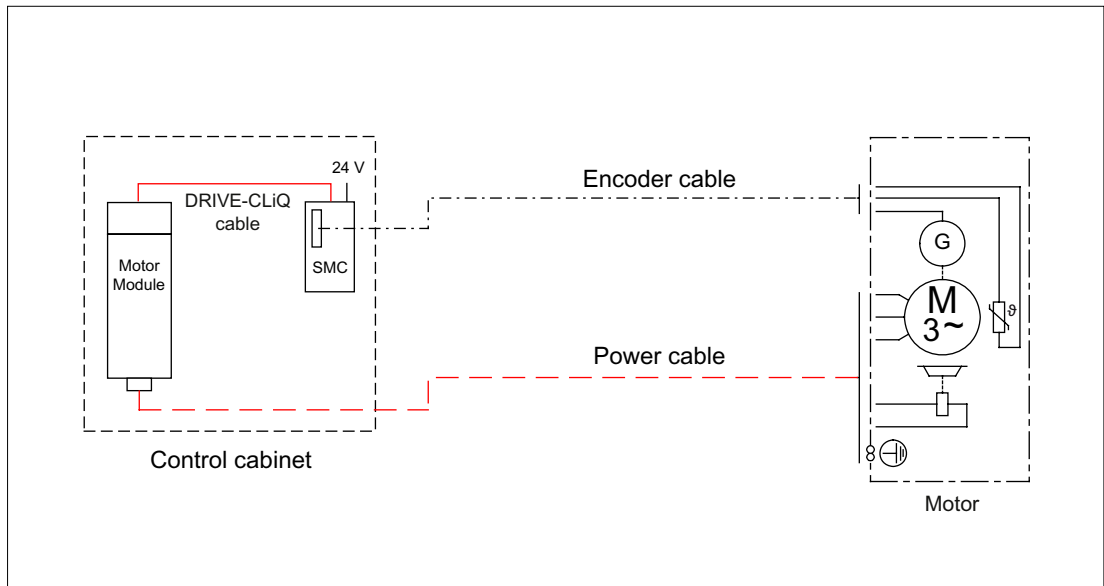

Figure 4-11 Connection of an encoder system via a Sensor Module Cabinet-Mounted (SMC) for a motor without a DRIVE-CLiQ interface

4.4.3.3 DRIVE-CLiQ interface X500

Table 4- 8 DRIVE-CLiQ interface X500

	Pin	Signal name	Technical specifications
	1	TXP	Transmit data +
	2	TXN	Transmit data -
	3	RXP	Receive data +
	4	Reserved, do not use	
	5	Reserved, do not use	
	6	RXN	Receive data -
	7	Reserved, do not use	
	8	Reserved, do not use	
	A	Reserved, do not use	
	B	GND (0 V)	Electronics ground

4.4.3.4 X520 encoder system interface

Table 4- 9 X520 encoder system interface

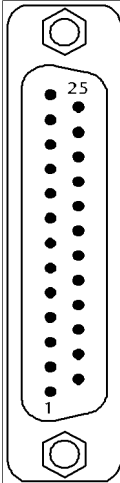
	Pin	Signal name	Technical specifications
	1	P encoder	Encoder power supply
	2	M encoder	Ground for encoder power supply
	3	A	Incremental signal A
	4	A*	Inverse incremental signal A
	5	Ground	Ground (for internal shield)
	6	B	Incremental signal B
	7	B*	Inverse incremental signal B
	8	Ground	Ground (for internal shield)
	9	Reserved, do not use	
	10	Clock	Clock, EnDat interface, SSI clock
	11	Reserved, do not use	
	12	Clock*	Inverted clock, EnDat interface, inverted SSI clock
	13	+ Temp	Motor temperature measurement KTY84-1C130 (KTY+) Temperature sensor KTY84-1C130 / PTC
	14	P sense	Sense input encoder power supply
	15	Data	Data, EnDat interface, SSI data
	16	M sense	Ground sense input encoder power supply
	17	R	Reference signal R
	18	R*	Inverse reference signal R
	19	C	Absolute track signal C
	20	C*	Inverse absolute track signal C
	21	D	Absolute track signal D
	22	D*	Inverse absolute track signal D
	23	Data*	Inverse data, EnDat interface, Inverse SSI data
	24	Ground	Ground (for internal shield)
	25	- Temp	Motor temperature measurement KTY84-1C130 (KTY-) Temperature sensor KTY84-1C130 / PTC

⚠ DANGER

Risk of electric shock!

Only temperature sensors that meet the safety isolation specifications contained in EN 61800-5-1 may be connected to terminals "+Temp" and "-Temp". If safe electrical separation cannot be guaranteed (for linear motors or third-party motors, for example), a Sensor Module External (SME120 or SME125) or Terminal Module TM120 must be used.

If these instructions are not complied with, there is a risk of electric shock!

4.4.3.5 X524 Electronics power supply

Table 4- 10 X524 terminal block

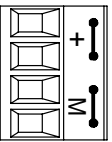
	Terminal	Function	Technical specifications
	+	Electronics power supply	Voltage: 24 V (20.4 V – 28.8 V) Current consumption: Max. 0.35 A Maximum current via jumper in connector: 20 A
	+	Electronics power supply	
	M	Electronics ground	
	M	Electronics ground	
Max. connectable cross-section: 2.5 mm ² Type: Screw terminal 2 (see Appendix A)			

Note

The two "+" and "M" terminals are jumpered in the connector. This ensures that the supply voltage is looped through.

4.4.3.6 Meaning of LEDs on the Sensor Module Cabinet-Mounted SMC20

Table 4- 11 Sensor Module Cabinet-Mounted SMC20 – description of the LEDs

LED	Color	Status	Description, cause	Remedy
RDY READY	-	Off	Electronics power supply is missing or outside permissible tolerance range.	-
	Green	Continuous light	The component is ready for operation and cyclic DRIVE-CLiQ communication is taking place.	-
	Orange	Continuous light	DRIVE-CLiQ communication is being established.	-
	Red	Continuous light	At least one fault is present in this component. Note: The LED is activated regardless of whether the corresponding messages have been reconfigured.	Remedy and acknowledge fault
	Green/red	0.5 Hz flashing light	Firmware is being downloaded.	-
		2 Hz flashing light	Firmware download is complete. Wait for POWER ON	Carry out a POWER ON
	Green/ orange or Red/ orange	Flashing light	Component recognition via LED is activated (p0144). Note: Both options depend on the LED status when component recognition is activated via p0144 = 1.	-

Cause and rectification of faults

The following reference contains information about the cause of faults and how they can be rectified:

/IH1/ SINAMICS S120 Commissioning Manual

/LH1/ SINAMICS S List Manual

4.4.4 Dimension drawing

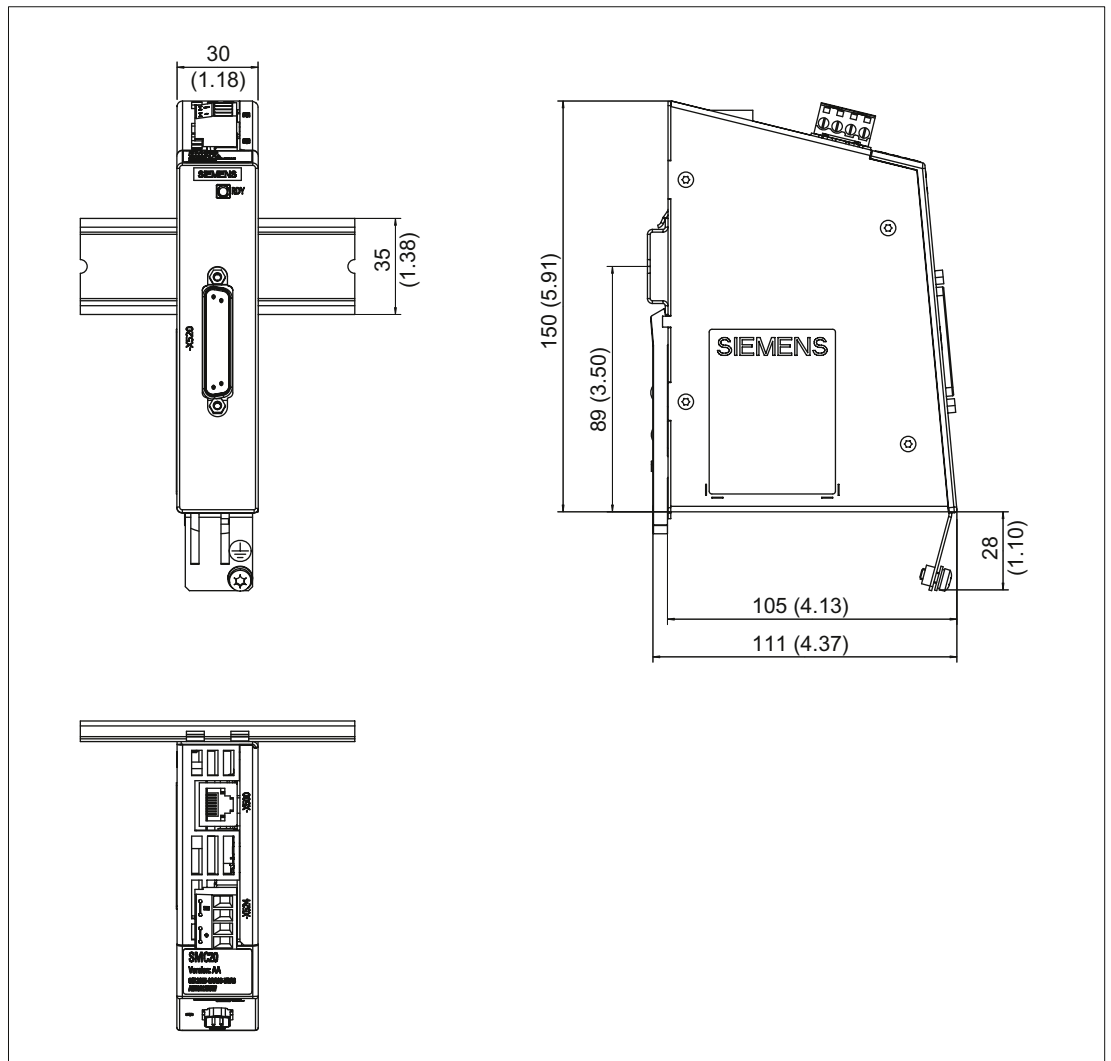

Figure 4-12 Dimension drawing of the Sensor Module Cabinet SMC20, all data in mm and (inches)

4.4.5 Installation

Installation

1. Tilt the component backwards slightly and attach it to the DIN rail using the hook.
2. Push the component towards the DIN rail until you hear the mounting slide at the rear latch into position.
3. You can now move the component to the left or right along the DIN rail, until it reaches its final position.

Removal

1. The lug on the mounting slide first needs to be pushed down to unlock the slide from the DIN rail.
2. The component can now be tilted forwards and pulled up and off the DIN rail.

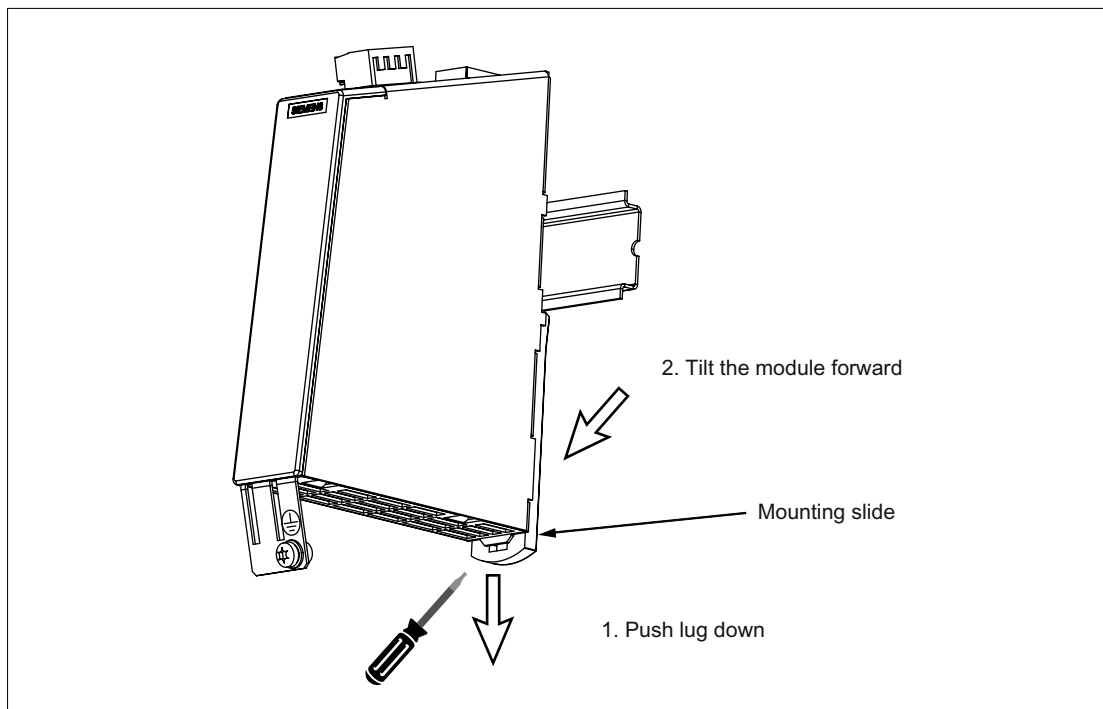

Figure 4-13 Removal of a component from a DIN rail

4.4.6 Technical data

Table 4- 12 Technical data

6SL3055-0AA00-5BAx	Unit	Value
Electronics power supply		
Voltage	V _{DC}	24 DC (20.4 – 28.8)
Current (without encoder system)	A _{DC}	≤ 0.20
Current (with encoder system)	A _{DC}	≤ 0.35
Power loss	W	≤ 10
Encoder system power supply		
Voltage	V _{encoder}	5 V DC (with Remote Sense) ¹⁾
Current	A _{encoder}	0.35
Encoder frequency that can be evaluated (f _{encoder})	kHz	≤ 500
SSI baud rate ²⁾	kHz	100 (6SL3055-0AA00-5BA2) 100 - 250 (6SL3055-0AA00-5BA3)
Max. encoder cable length	m	100
PE/ground connection		On housing with M4/1.8 Nm screw
Weight	kg	0.45
Degree of protection		IP20 or IPXXB

1) A controller compares the encoder system supply voltage - sensed via the Remote Sense cables - with the reference supply voltage of the encoder system, and adjusts the supply voltage for the encoder system at the output of the drive module until the required supply voltage is obtained directly at the encoder system (only for 5 V encoder system power supply).

2) Only possible for SSI encoders with 5 V supply

4.5 Sensor Module Cabinet-Mounted SMC30

4.5.1 Description

The Sensor Module Cabinet-Mounted SMC30 evaluates encoder signals and transmits the speed, actual position value and, if necessary, the motor temperature and reference point via DRIVE-CLiQ to the Control Unit.

The SMC30 is used to evaluate encoder signals from encoders with TTL, HTL, or SSI interfaces.

A combination of TTL/HTL signal and SSI absolute signal is possible at terminals X521/X531, if both signals are derived from the same measured variable.

4.5.2 Safety information

 WARNING
The ventilation spaces of 50 mm above and below the component must be observed.

NOTICE
Only one encoder system may be connected per Sensor Module.

Note

There must be no electrical connection between the encoder system housing and the signal cables, or the encoder system electronics. If this is not carefully observed, under certain circumstances the system will not be able to reach the required interference immunity level (there is then a danger of equalization currents flowing through the electronics ground).

CAUTION
When the encoder system is connected via terminals, make sure that the cable shield is connected to the component.

 CAUTION
Connecting cables to temperature sensors must always be installed with shielding. The cable shield must be connected to the ground potential at both ends over a large surface area. Temperature sensor cables that are routed together with the motor cable must be twisted in pairs and shielded separately.

4.5.3 Interface description

4.5.3.1 Overview

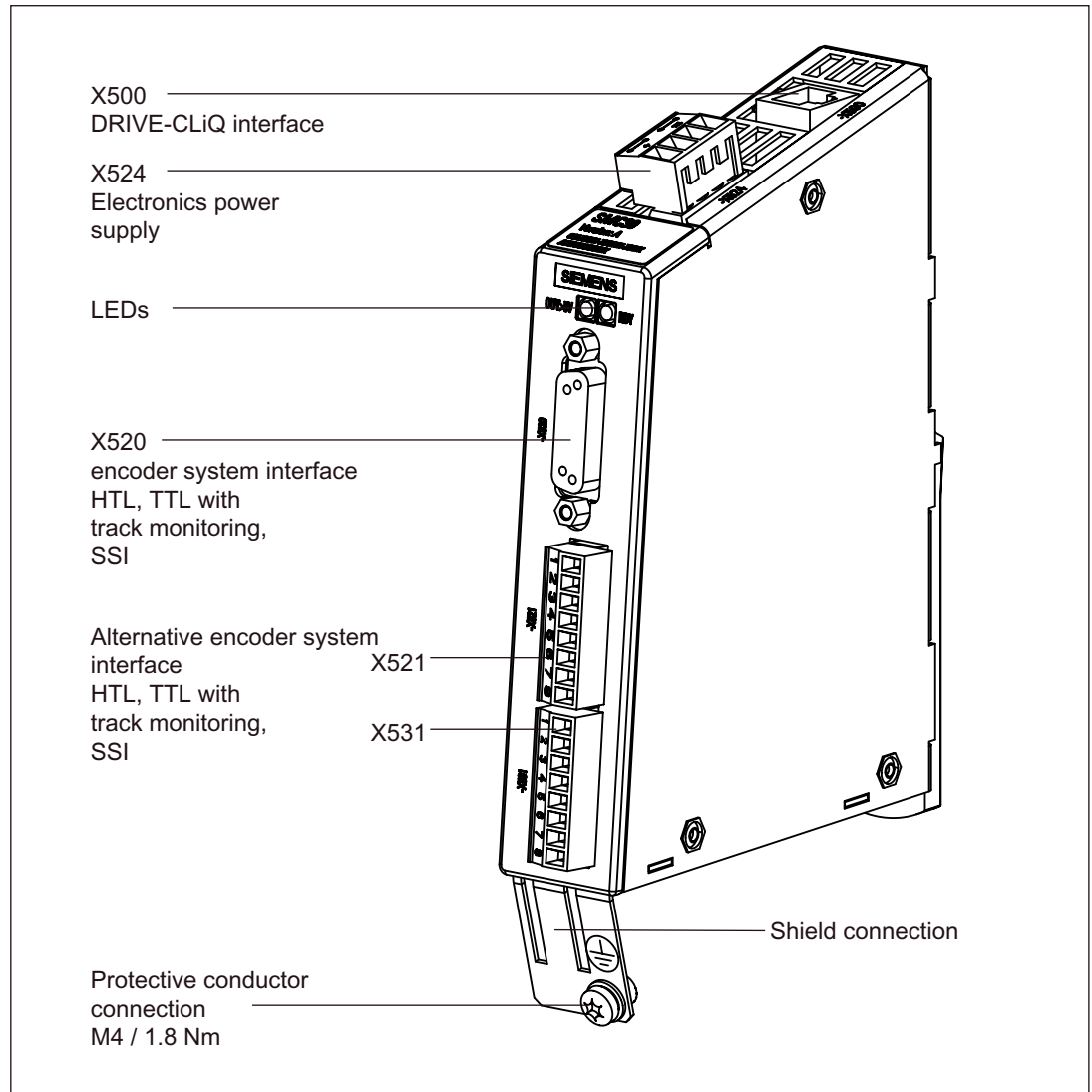

Figure 4-14 Interface description of the SMC30

4.5.3.2 Connection examples

Connection example 1: HTL encoder, bipolar, with reference signal

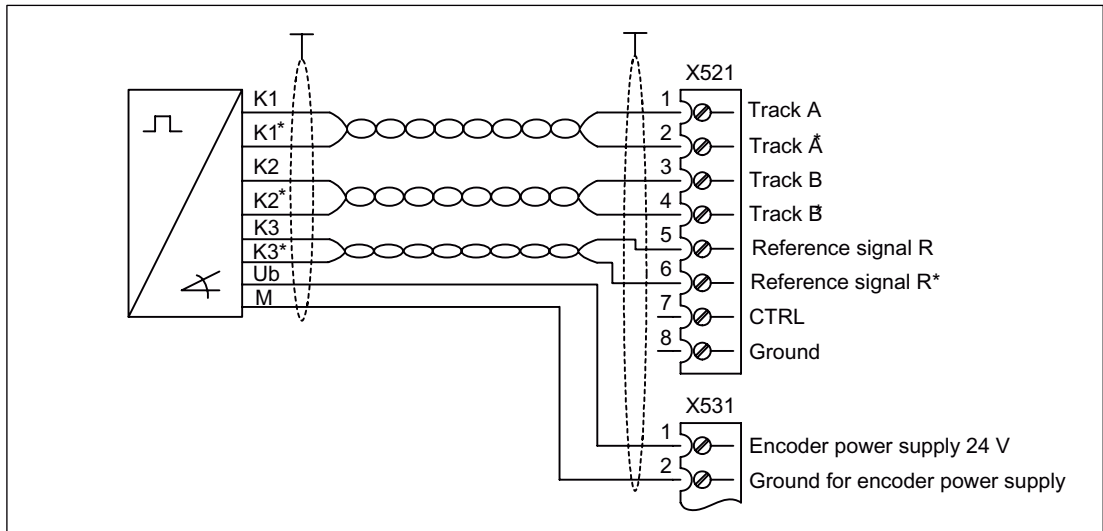

Figure 4-15 Connection example 1: HTL encoder, bipolar, with reference signal

Signal cables must be twisted in pairs in order to improve noise immunity against induced noise.

Connection example 2: HTL encoder, unipolar, with reference signal

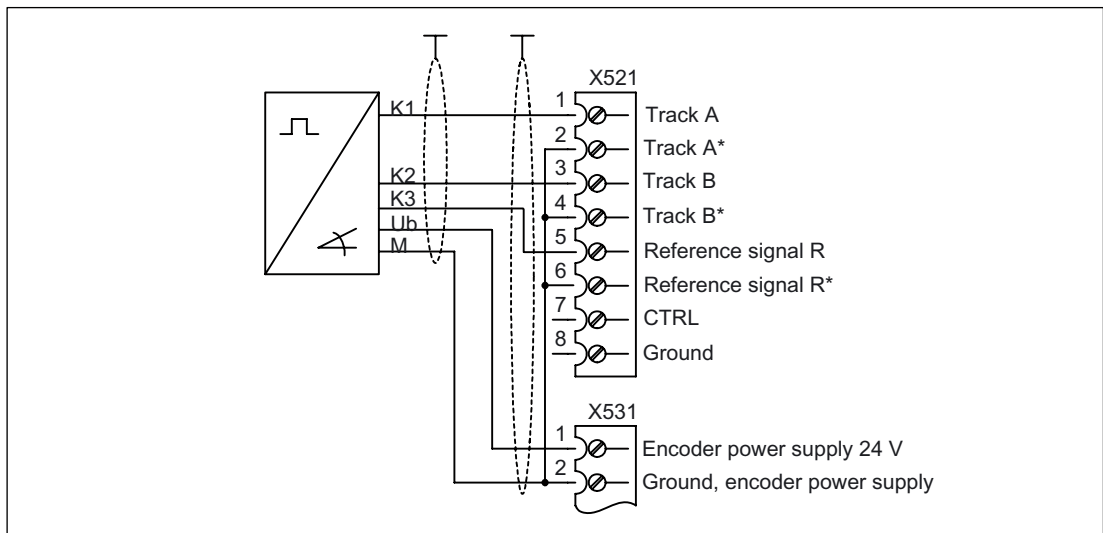

Figure 4-16 Connection example 2: HTL encoder, unipolar, with reference signal¹⁾

¹⁾ Because the physical transmission media is more robust, the bipolar connection should always be used. The unipolar connection should only be used if the encoder type does not output push-pull signals.

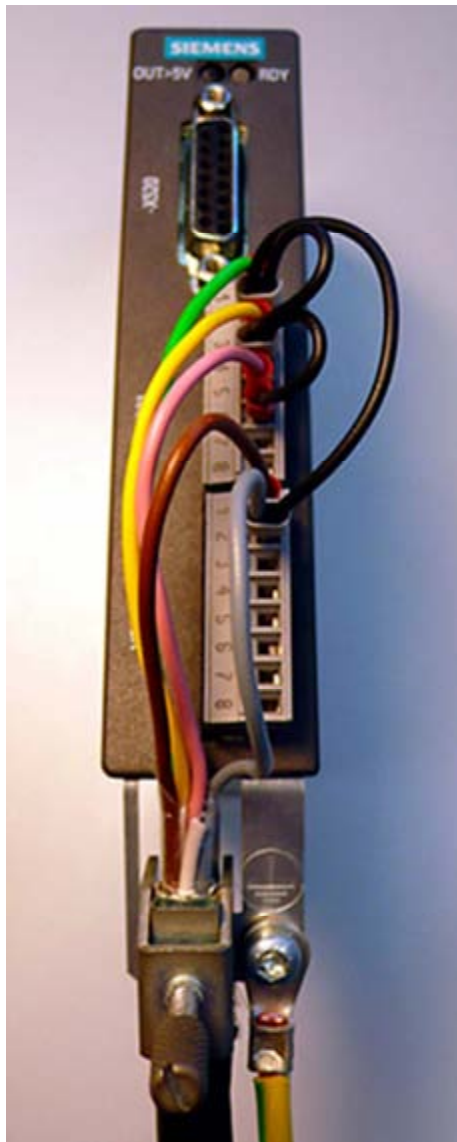
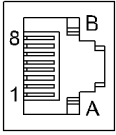

Figure 4-17 Photo of connection example 2: SMC30, 30 mm wide

Note: Diagram of the wire jumpers to connect unipolar HTL encoders with reference signal

4.5.3.3 DRIVE-CLiQ interface X500

Table 4- 13 DRIVE-CLiQ interface X500

	Pin	Signal name	Technical specifications
	1	TXP	Transmit data +
	2	TXN	Transmit data -
	3	RXP	Receive data +
	4	Reserved, do not use	
	5	Reserved, do not use	
	6	RXN	Receive data -
	7	Reserved, do not use	
	8	Reserved, do not use	
	A	Reserved, do not use	
	B	GND (0 V)	Electronics ground

4.5.3.4 X520 encoder system interface

Table 4- 14 X520 encoder system interface

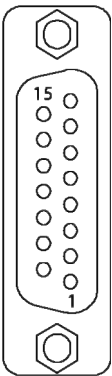
	Pin	Signal name	Technical specifications
	1	Reserved, do not use + Temp	Motor temperature sensing KTY84-1C130 (KTY+) Temperature sensor KTY84-1C130/PTC/bimetallic switch with NC contact
	2	Clock	SSI clock
	3	Clock*	Inverse SSI clock
	4	P encoder 5 V / 24 V	Encoder power supply
	5	P encoder 5 V / 24 V	
	6	P sense	Sense input encoder power supply
	7	M encoder (M)	Ground for encoder power supply
	8	Reserved, do not use - Temp	Motor temperature sensing KTY84-1C130 (KTY-) Temperature sensor KTY84-1C130/PTC/bimetallic switch with NC contact
	9	M sense	Ground sense input
	10	R	Reference signal R
	11	R*	Inverse reference signal R
	12	B*	Inverse incremental signal B
	13	B	Incremental signal B
	14	A* / data*	Inverse incremental signal A/inverse SSI data
	15	A / data	Incremental signal A/SSI data

Type: 15-pin Sub-D connector

CAUTION

The sensor power supply can be parameterized to 5 V or 24 V. The sensor may be destroyed if you enter the wrong parameters.

DANGER

Risk of electric shock!

Only temperature sensors that meet the safety isolation specifications contained in EN 61800-5-1 may be connected to terminals "+Temp" and "-Temp". If safe electrical separation cannot be guaranteed (for linear motors or third-party motors, for example), a Sensor Module External (SME120 or SME125) or Terminal Module TM120 must be used.

If these instructions are not complied with, there is a risk of electric shock!

4.5.3.5 X521 / X531 alternative encoder system interface

Table 4- 15 X521 / X531 alternative encoder system interface

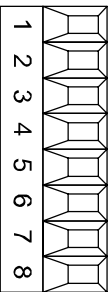
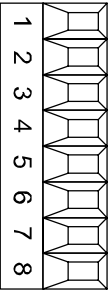
	Pin	Designation	Technical specifications
<p>X521</p> 	1	A	Incremental signal A
	2	A*	Inverse incremental signal A
	3	B	Incremental signal B
	4	B*	Inverse incremental signal B
	5	R	Reference signal R
	6	R*	Inverse reference signal R
	7	CTRL	Control signal
	8	M	Ground
<p>X531</p> 	1	P_Encoder 5 V / 24 V	Encoder power supply
	2	M_Encoder	Ground for encoder power supply
	3	- Temp	Motor temperature sensing KTY84-1C130 (KTY-) Temperature sensor KTY84-1C130/PTC/bimetallic switch with NC contact
	4	+ Temp	Motor temperature sensing KTY84-1C130 (KTY+) Temperature sensor KTY84-1C130/PTC/bimetallic switch with NC contact
	5	Clock	SSI clock
	6	Clock*	Inverse SSI clock
	7	Data	SSI data
	8	Data*	Inverse SSI data
<p>Max. connectable cross-section: 1.5 mm² When using unipolar HTL encoders, at the terminal block A*, B*, R* must be connected to (jumper) M_Encoder (X531)¹⁾.</p>			

1) Because the physical transmission media is more robust, the bipolar connection should always be used. The unipolar connection should only be used if the encoder type does not output push-pull signals.

CAUTION

When the encoder system is connected via terminals, make sure that the cable shield is connected to the component. Refer to the Chapter "Electrical connection".

⚠ DANGER

Risk of electric shock!

Only temperature sensors that meet the safety isolation specifications contained in EN 61800-5-1 may be connected to terminals "+Temp" and "-Temp". If safe electrical separation cannot be guaranteed (for linear motors or third-party motors, for example), a Sensor Module External (SME120 or SME125) or Terminal Module TM120 must be used.

If these instructions are not complied with, there is a risk of electric shock!

4.5.3.6 X524 Electronics power supply

Table 4- 16 X524 terminal block

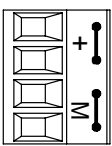
	Terminal	Function	Technical specifications
	+	Electronics power supply	Voltage: 24 V (20.4 V – 28.8 V) Current consumption: max. 0.55 A Max. current via jumper in connector: 20 A
	+	Electronics power supply	
	M	Electronics ground	
	M	Electronics ground	
Max. connectable cross-section: 2.5 mm ² Type: Screw terminal 2 (see Appendix A)			

Note

The two "+" and "M" terminals are jumpered in the connector. This ensures that the supply voltage is looped through.

4.5.3.7 Meaning of LEDs on the Sensor Module Cabinet-Mounted SMC30

Table 4- 17 Sensor Module Cabinet SMC30 – description of the LEDs

LED	Color	Status	Description, cause	Remedy
RDY READY	-	Off	Electronics power supply is missing or outside permissible tolerance range.	-
	Green	Continuous light	The component is ready for operation and cyclic DRIVE-CLiQ communication is taking place.	-
	Orange	Continuous light	DRIVE-CLiQ communication is being established.	-
	Red	Continuous light	At least one fault is present in this component. Note: The LED is activated regardless of whether the corresponding messages have been reconfigured.	Remedy and acknowledge fault
	Green/red	0.5 Hz flashing light	Firmware is being downloaded.	-
	Green/red	2 Hz flashing light	Firmware download is complete. Wait for POWER ON.	Carry out a POWER ON
	Green/ orange or Red/ orange	Flashing light	Component recognition via LED is activated (p0144). Note: Both options depend on the LED status when component recognition is activated via p0144 = 1.	-
OUT > 5 V	-	Off	Electronics power supply is missing or outside permissible tolerance range. Power supply \leq 5 V.	-
	Orange	Continuous light	Electronics power supply for encoder system available. Power supply > 5 V. Important: Make sure that the connected encoder can be operated with a 24 V power supply. If an encoder that is designed for a 5 V supply is operated with a 24 V supply, this can destroy the encoder electronics.	-

Cause and rectification of faults

The following reference contains information about the cause of faults and how they can be rectified:

/IH1/ SINAMICS S120 Commissioning Manual

/LH1/ SINAMICS S List Manual

4.5.4 Dimension drawing

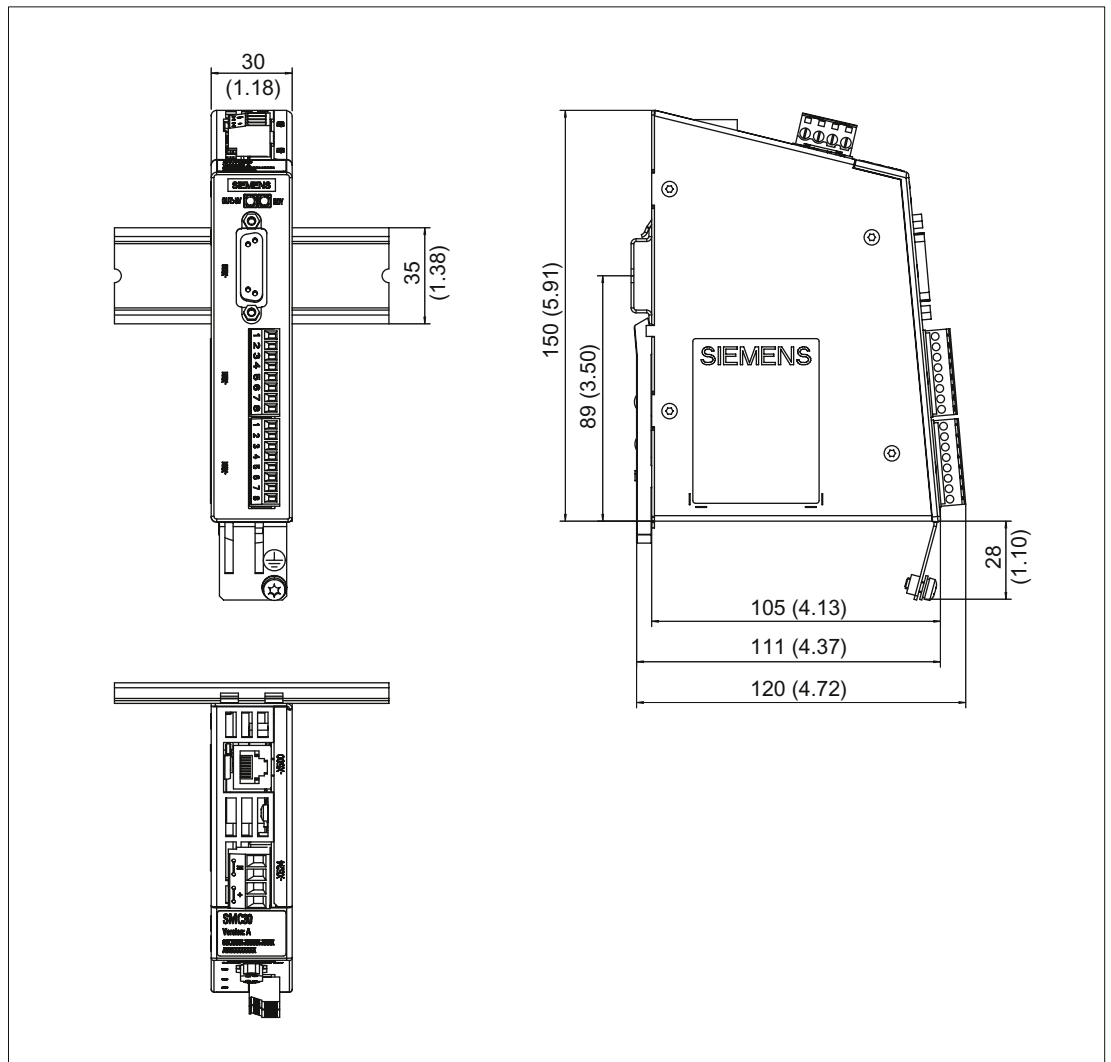

Figure 4-18 Dimension drawing of the Sensor Module Cabinet SMC30, all data in mm and (inches)

4.5.5 Installation

Installation

1. Tilt the component backwards slightly and attach it to the DIN rail using the hook.
2. Push the component towards the DIN rail until you hear the mounting slide at the rear latch into position.
3. You can now move the component to the left or right along the DIN rail, until it reaches its final position.

Removal

1. The lug on the mounting slide first needs to be pushed down to unlock the slide from the DIN rail.
2. The component can now be tilted forwards and pulled up and off the DIN rail.

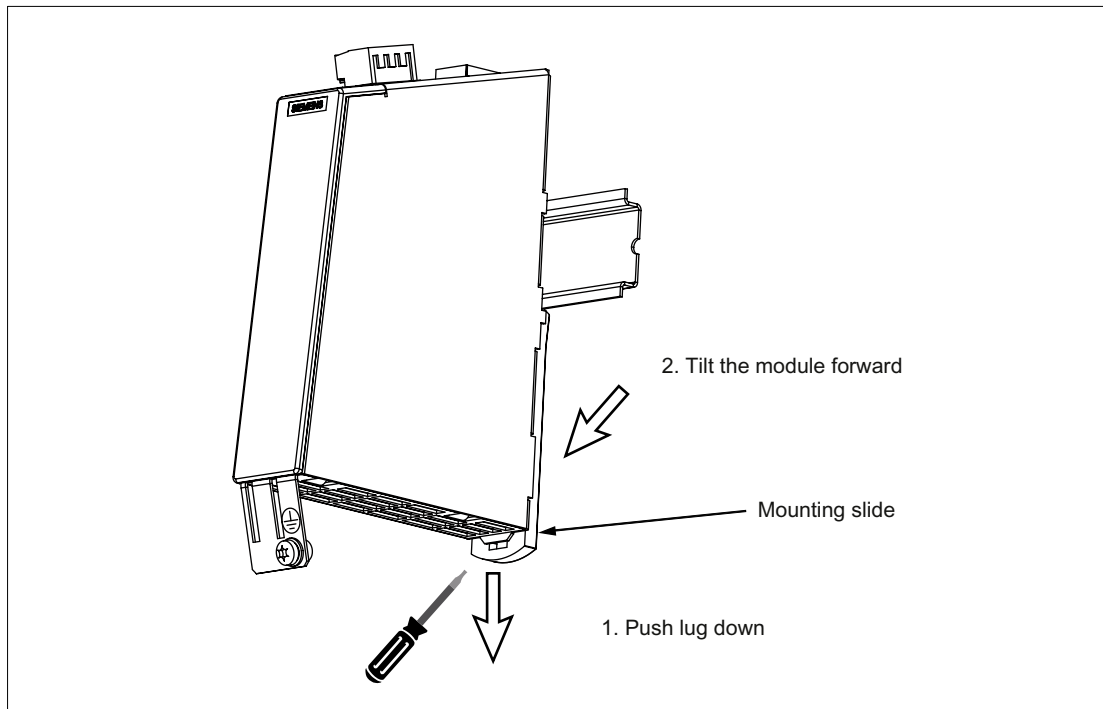

Figure 4-19 Removal of a component from a DIN rail

4.5.6 Protective conductor connection and shield support

Shield contacts are only required if the system is connected to X521/X531.

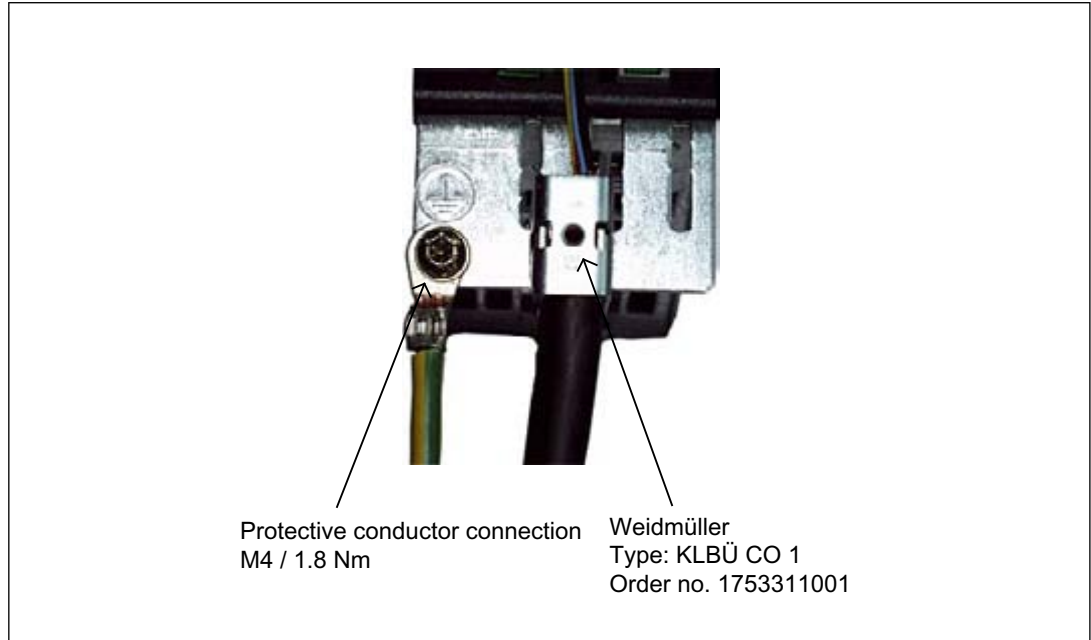

Figure 4-20 Shield contacts for the SMC30

Weidmüller website address: <http://www.weidmueller.com>

The bending radii of the cables must be taken into account (see MOTION-CONNECT description).

NOTICE

Only use screws with a permissible mounting depth of 4 - 6 mm.

4.5.7 Technical data

Table 4- 18 Technical data

6SL3055-0AA00-5CAx	Unit	Value
Electronics power supply		
Voltage	V_{DC}	24 DC (20.4 – 28.8)
Current (without encoder system)	A_{DC}	≤ 0.20
Current (with encoder system)	A_{DC}	≤ 0.55
Power loss	W	≤ 10
Encoder system power supply		
Voltage	$V_{encoder}$	5 VDC (with or without Remote Sense) ¹⁾ or $V_{DC} - 1 V$
Current	$A_{encoder}$	0.35
Encoder frequency that can be evaluated ($f_{encoder}$)	kHz	≤ 300
SSI baud rate	kHz	100 - 250
PE/ground connection		On housing with M4/1.8 Nm screw
Weight		0.45
Degree of protection		IP20 or IPXXB

1) A controller compares the encoder system supply voltage - sensed via the Remote Sense cables - with the reference supply voltage of the encoder system, and adjusts the supply voltage for the encoder system at the output of the drive module until the required supply voltage is obtained directly at the encoder system (only for 5 V encoder system power supply). Remote Sense only to X520.

Table 4- 19 Specification of encoder systems that can be connected

Parameter	Designation	Threshold	Min.	Max.	Unit
High signal level (TTL bipolar at X520 or X521/X531) ¹⁾	U_{Hdiff}		2	5	V
Low signal level (TTL bipolar at X520 or X521/X531) ¹⁾	U_{Ldiff}		-5	-2	V
Signal level high (HTL unipolar)	$U_H^{3)}$	High	17	V_{CC}	V
		Low	10	V_{CC}	V
Signal level low (HTL unipolar)	$U_L^{3)}$	High	0	7	V
		Low	0	2	V
High signal level (HTL bipolar) ²⁾	U_{Hdiff}		3	V_{CC}	V
Low signal level (HTL bipolar) ²⁾	U_{Ldiff}		$-V_{CC}$	-3	V
High signal level (SSI bipolar at X520 or X521/X531) ¹⁾	U_{Hdiff}		2	5	V
Low signal level (SSI bipolar at X520 or X521/X531) ¹⁾	U_{Ldiff}		-5	-2	V
Signal frequency	f_s		-	300	kHz
Edge clearance	t_{min}		100	-	ns
"Zero pulse inactive time" (before and after A=B=high)	t_{Lo}		640	$(t_{ALo-BHi} - t_{Hi})/2$ ⁴⁾	ns
"Zero pulse active time" (while A=B=high and beyond) ⁵⁾	t_{Hi}		640	$t_{ALo-BHi} - 2*t_{Lo}$ ⁴⁾	ns

- 1) Other signal levels according to the RS 422 standard.
- 2) The absolute level of the individual signals varies between 0 V and V_{CC} of the encoder system.
- 3) Only with order number 6SL3055-0AA00-5CA2 and firmware version 2.5 SP1 or higher can this value be configured using software. For older firmware releases and Order Nos. less than 6SL3055-0AA00-5CA2 then the "low" threshold applies.
- 4) $t_{ALo-BHi}$ is not a specified value, but is the time between the falling edge of track A and the next but one rising edge of track B.
- 5) Further information on setting the "Zero pulse active time" can be found in the following: References: /FH1/ SINAMICS S120, Function Manual, tolerant encoder monitoring for SMC30

Table 4- 20 Encoders that can be connected

	X520 (D-Sub)	X521 (terminal)	X531 (terminal)	Track monitoring	Remote Sense ²⁾
HTL bipolar 24 V	No/yes	Yes		No/yes	No
HTL unipolar 24 V ¹⁾	No/yes	Yes (however, a bipolar connection is recommended) ¹⁾		No	No
TTL bipolar 24 V	Yes	Yes		Yes	No
TTL bipolar 5 V	Yes	Yes		Yes	To X520
SSI 24 V/5 V	Yes	Yes		No	No
TTL unipolar	No				

- 1) Because the physical transmission media is more robust, the bipolar connection should always be used. The unipolar connection should only be used if the encoder type does not output push-pull signals.
- 2) A controller compares the encoder system supply voltage - sensed via the Remote Sense cables - with the reference supply voltage of the encoder system, and adjusts the supply voltage for the encoder system at the output of the drive module until the required supply voltage is obtained directly at the encoder system (only for 5 V encoder system power supply).

Table 4- 21 Maximum encoder cable length

Encoder type	Maximum encoder cable length in m
TTL ¹⁾	100
HTL unipolar ²⁾	100
HTL bipolar	300
SSI	100

- 1) For TTL encoders at X520 → Remote Sense → 100 m
- 2) Because the physical transmission media is more robust, the bipolar connection should always be used. The unipolar connection should only be used if the encoder type does not output push-pull signals.

For encoders with a 5 V supply at X521/X531, the cable lengths depend on the encoder current (for 0.5 mm² cable cross-sections):

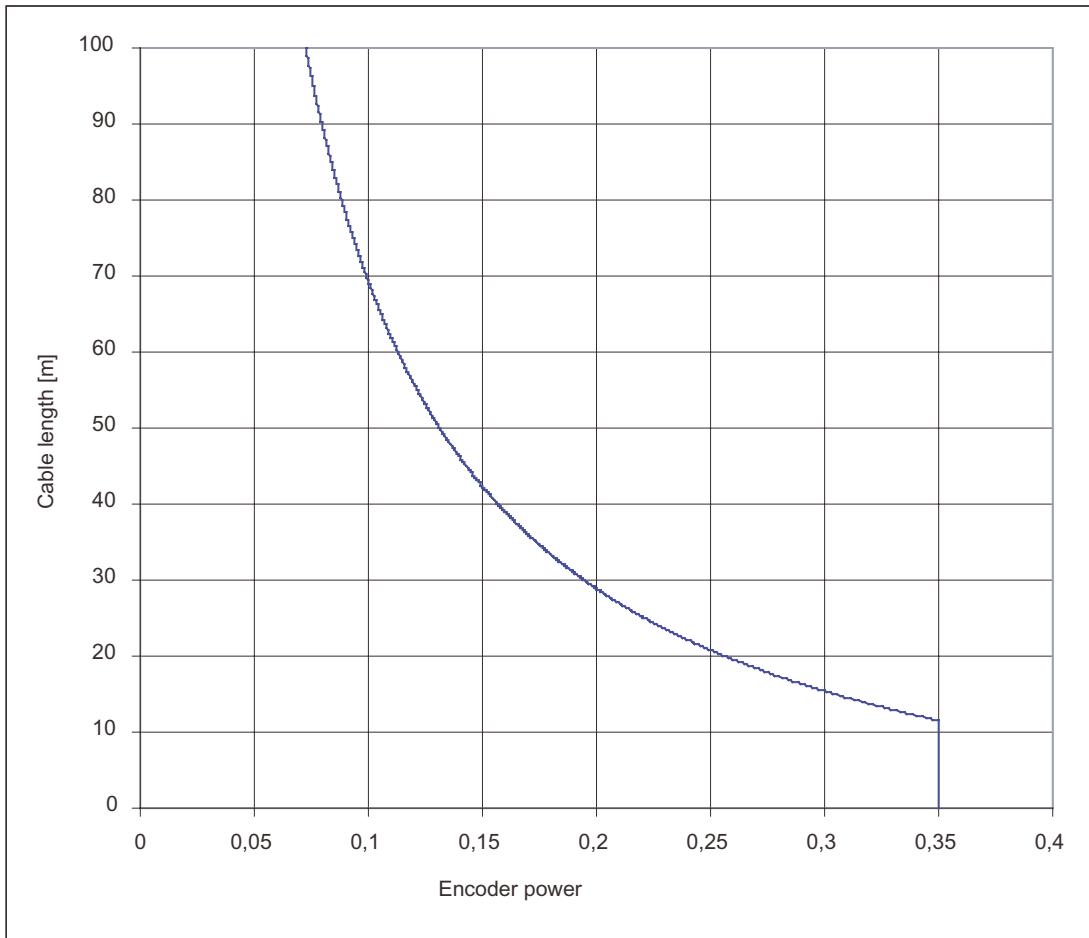

Figure 4-21 Max. cable length as a function of the encoder current drawn

For encoders without Remote Sense the permissible cable length is restricted to 100 m (reason: the voltage drop depends on the cable length and the encoder current).

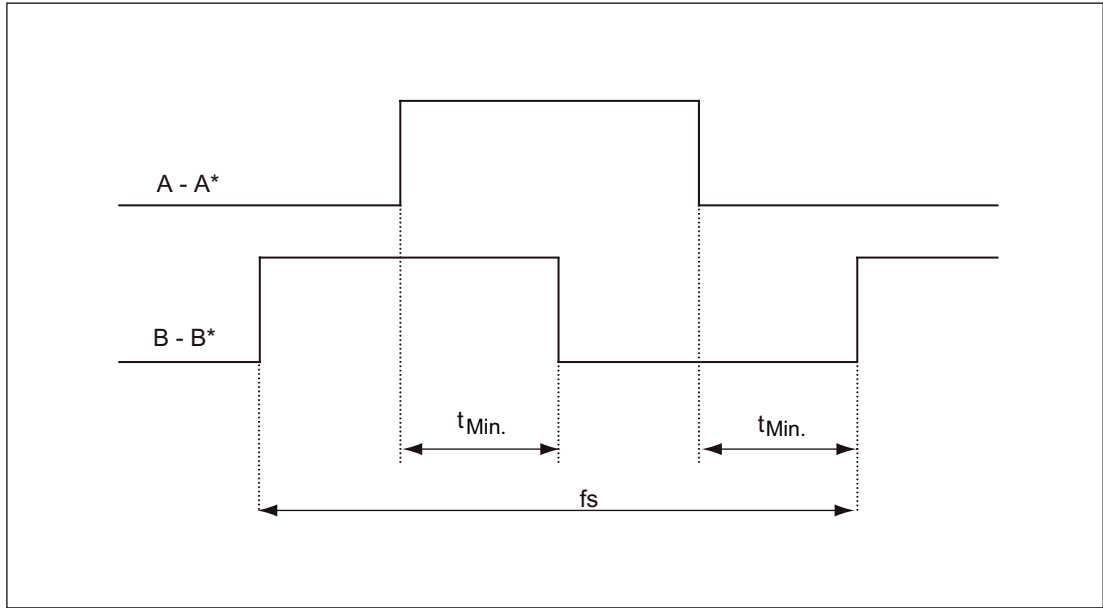

Figure 4-22 Signal characteristic of track A and track B between two edges: Time between two edges with pulse encoders

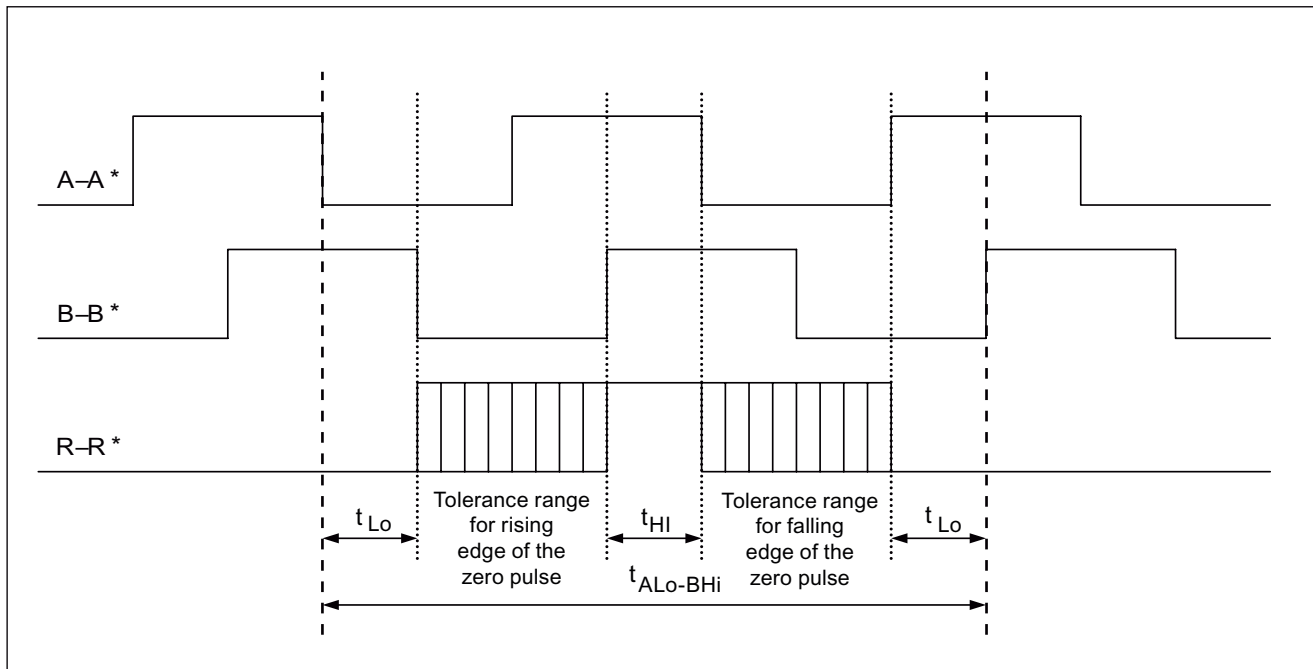

Figure 4-23 Position of the zero pulse to the track signals

4.6 Sensor Module External SME20

4.6.1 Description

Direct encoder systems outside the cabinet can be connected to the Sensor Module External SME20. The SME20 evaluates these encoder systems and converts the calculated values to DRIVE-CLiQ.

Incremental direct encoder systems with SIN/COS (1 Vpp) and reference signal can be connected.

It is possible to connect a motor with a 17-pole circular connector for the encoder to the 12-pole circular connector of the SME20 using adapter cable 6FX 8002-2CA88-xxxx.

- KTY/PTC temperature sensors can be used for evaluation of the motor temperature.
- The Sensor Module is only suitable for motors without absolute track signals (C/D track):
 - Induction motors (e.g. 1PH)
 - Synchronous motors with pole position identification (e.g. 1FN, 1FW, 1FE)

Neither motor nor encoder data are saved in the SME20.

The SME20 can be operated with firmware version 2.3 or higher.

4.6.2 Safety Information

CAUTION
Connecting cables to temperature sensors must always be installed with shielding. The cable shield must be connected to the chassis potential at both ends over a large surface area. Temperature sensor cables that are routed together with the motor cable must be twisted in pairs and shielded separately.

4.6.3 Interface description

4.6.3.1 Overview

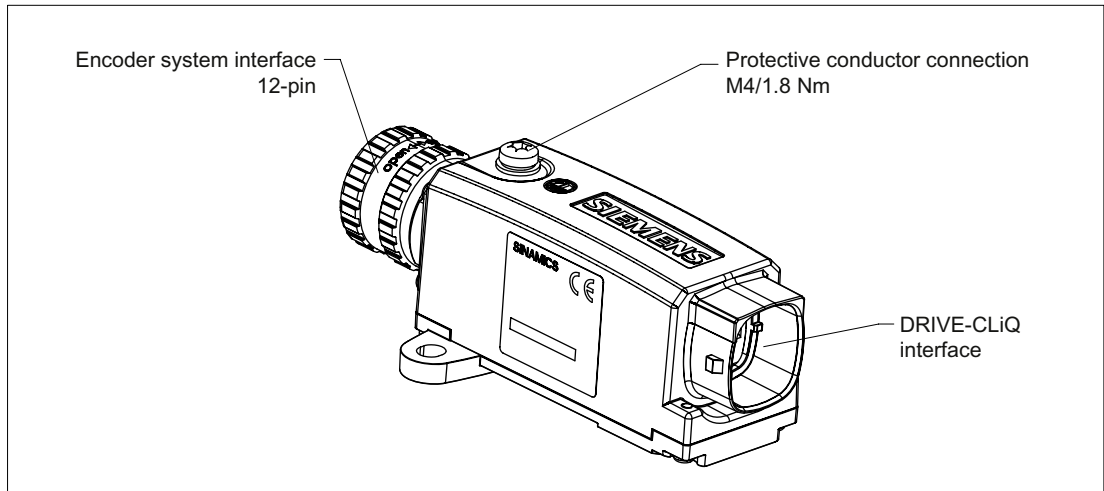

Figure 4-24 Interface description SME20

4.6.3.2 Connection example

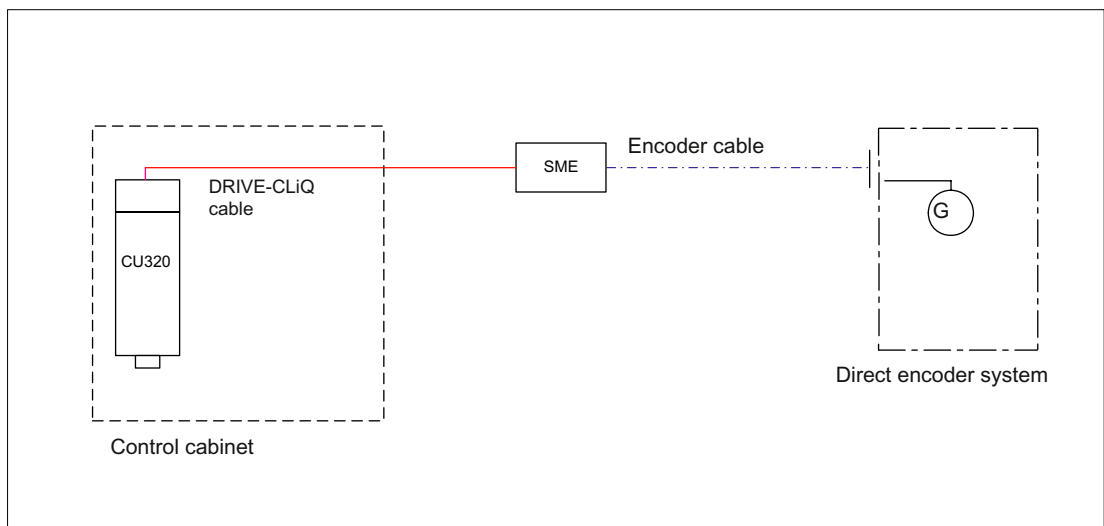
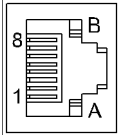

Figure 4-25 Connection of a direct encoder system via a Sensor Module External (SME)

4.6.3.3 DRIVE-CLiQ interface

Table 4- 22 DRIVE-CLiQ interface

	Pin	Signal name	Technical specifications	
	1	TXP	Transmit data +	
	2	TXN	Transmit data -	
	3	RXP	Receive data +	
	4	Reserved, do not use		
	5	Reserved, do not use		
	6	RXN	Receive data -	
	7	Reserved, do not use		
	8	Reserved, do not use		
	A	+ (24 V)	Power supply	
	B	M (0 V)	Electronics ground	
	Cover for the DRIVE-CLiQ interface is included in the scope of supply Current consumption: max. 0.25 A			

Note

Only MOTION-CONNECT DRIVE-CLiQ cables may be used for connections. With MOTION-CONNECT 500, the maximum cable length is 100 m; with MOTION-CONNECT 800, it is 50 m.

4.6.3.4 Encoder system interface

Table 4- 23 Encoder system interface SME20

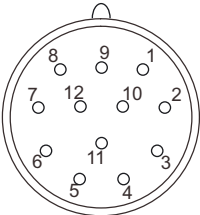
	Pin	Signal name	Technical specifications
	1	B*	Inverse incremental signal B
	2	P5	Encoder power supply
	3	R	Reference signal R
	4	R*	Inverse reference signal R
	5	A	Incremental signal A
	6	A*	Inverse incremental signal A
	7	-Temp	Temperature sensor connection ¹⁾ KTY841-C130 or PTC
	8	B	Incremental signal B
	9	+Temp	Temperature sensor connection ¹⁾ KTY841-C130 or PTC
	10	M	Ground for encoder power supply
	11	M	Ground for encoder power supply
	12	P5	Encoder power supply

Blanking plate for encoder system interface: Pöppelmann GmbH & Co. KG, Lohne,
 Order No.: GPN 300 F211
 connector kits, 12-pole, Order No.: 6FX2003-0SA12

1) Connection cable: Order number 6FX8002-2CA88-xxxx

 DANGER
Risk of electric shock! Only temperature sensors that meet the safety isolation specifications contained in EN 61800-5-1 may be connected to terminals "+Temp" and "-Temp". If safe electrical separation cannot be guaranteed (for linear motors or third-party motors, for example), a Sensor Module External (SME120 or SME125) or Terminal Module TM120 must be used. If these instructions are not complied with, there is a risk of electric shock!

4.6.4 Dimension drawings

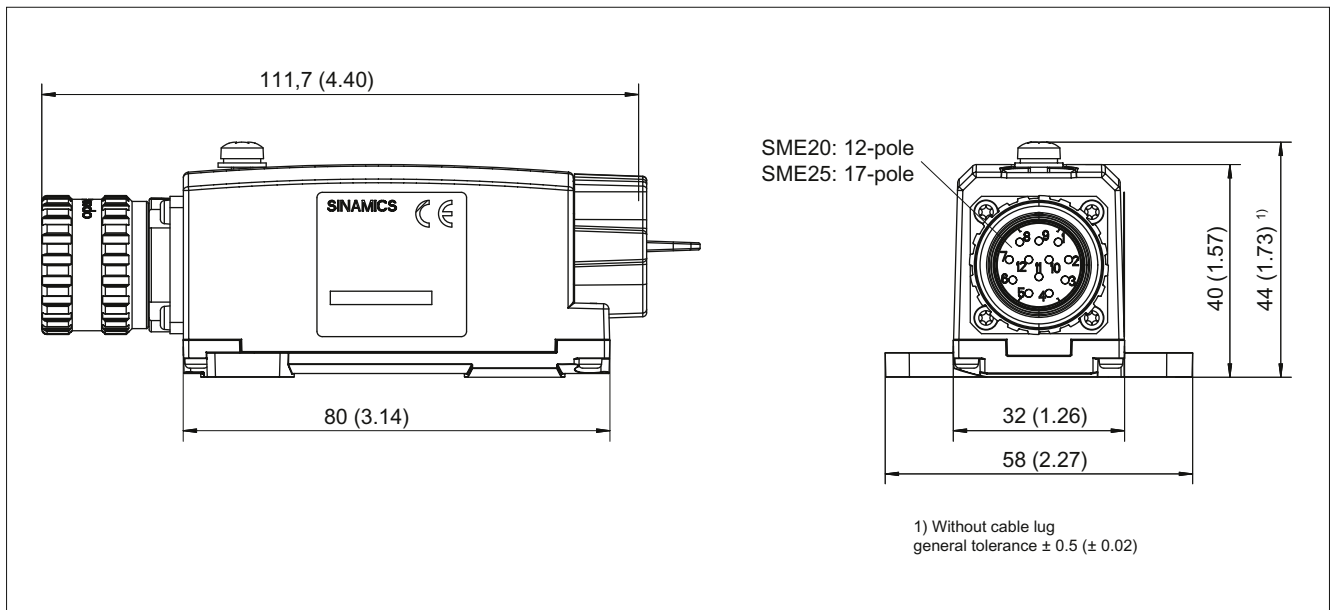

Figure 4-26 Dimension drawing of Sensor Module External SME20, all data in mm and (inches), order number 6SL3055-0AA00-5EA3

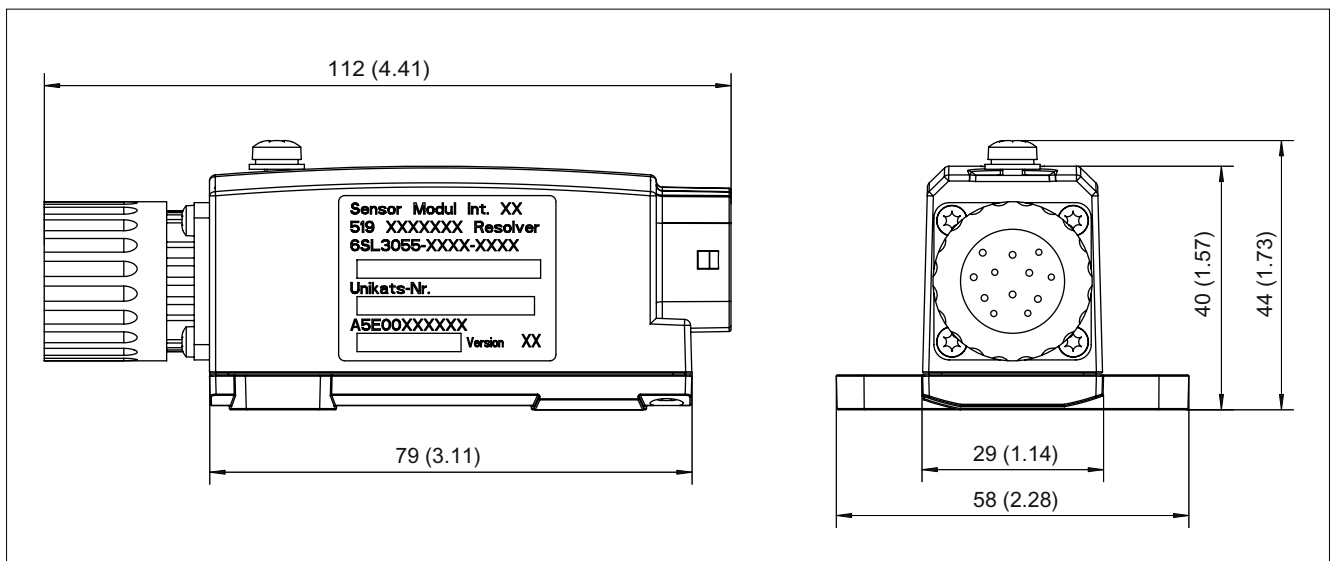

Figure 4-27 Dimension drawing of Sensor Module External SME20, all data in mm and (inches), order number 6SL3055-0AA00-5EA0

Note

Sensor Module External SME20 with order number 6SL3055-0AA00-5EA0 **cannot** be operated with version 4.x drive runtime software.

4.6.5 Installation

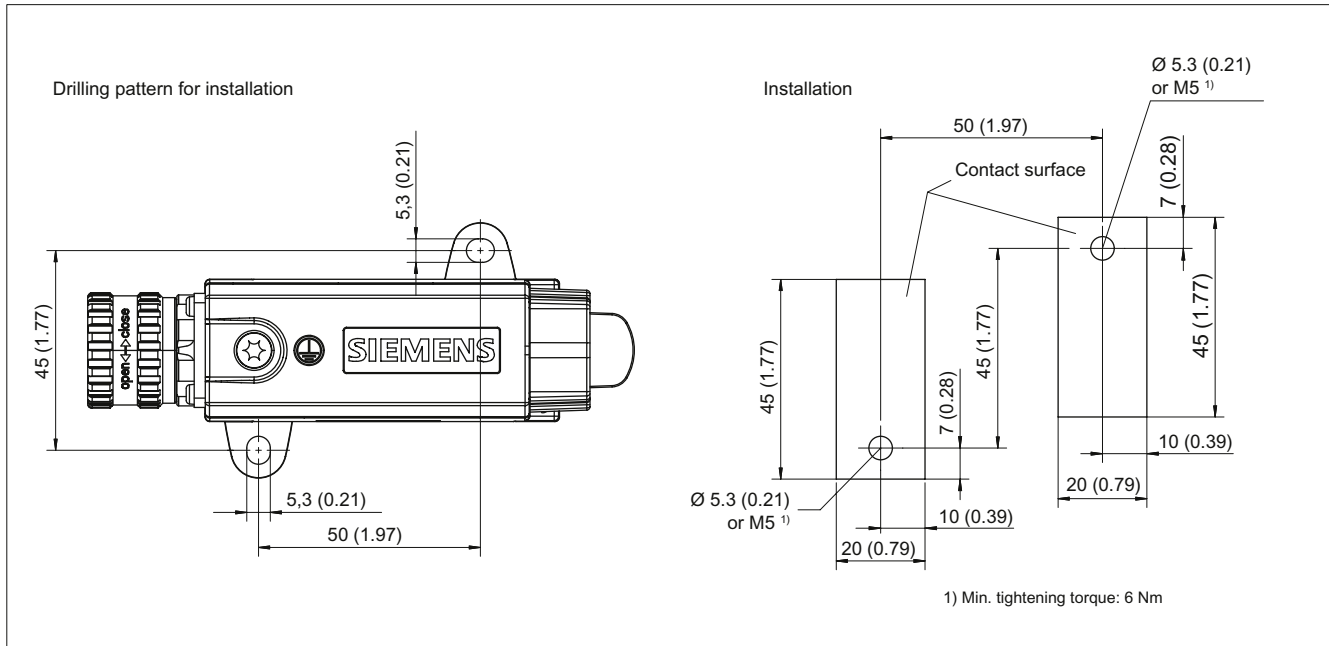

Figure 4-28 SME20/SME25 installation

Procedure

1. Place the drilling pattern on the bright contact surface
2. Holes Ø 5.3 or threads M5
3. Tighten with a min. torque of 6 Nm.

4.6.6 Technical data

Table 4- 24 Technical data

6SL3055-0AA00-5EAx	Unit	Value
Electronics power supply		
Voltage	V _{DC}	24 DC (20.4 – 28.8)
Current (without encoder system)	A _{DC}	≤ 0.15
Current (with encoder system)	A _{DC}	≤ 0.25
Power loss	W	≤ 4
Encoder system power supply		
Voltage	V _{encoder}	5 VDC
Current	A _{encoder}	0.35
Encoder frequency that can be evaluated (f _{encoder})	kHz	≤ 500
PE/ground connection		On housing with M4/1.8 Nm screw
Weight	kg	0.18 (order number 6SL3055-0AA00-5EA0) 0.31 (order number 6SL3055-0AA00-5EA3)
Degree of protection		IP67

The maximum cable length for the encoder system interface depends on the current consumption of the encoder system and the cross-section of the wire in the cable. However, the maximum length is 10 m. The figure below applies to encoder systems that operate in the supply voltage range between 4.75 V and 5.25 V. The sample parameters shown are 0.28 mm² cross-section (0.14 mm² supply plus 0.14 mm² Remote Sense wires) and 0.64 mm² (0.5 mm² supply plus 0.14 mm² Remote Sense wires).

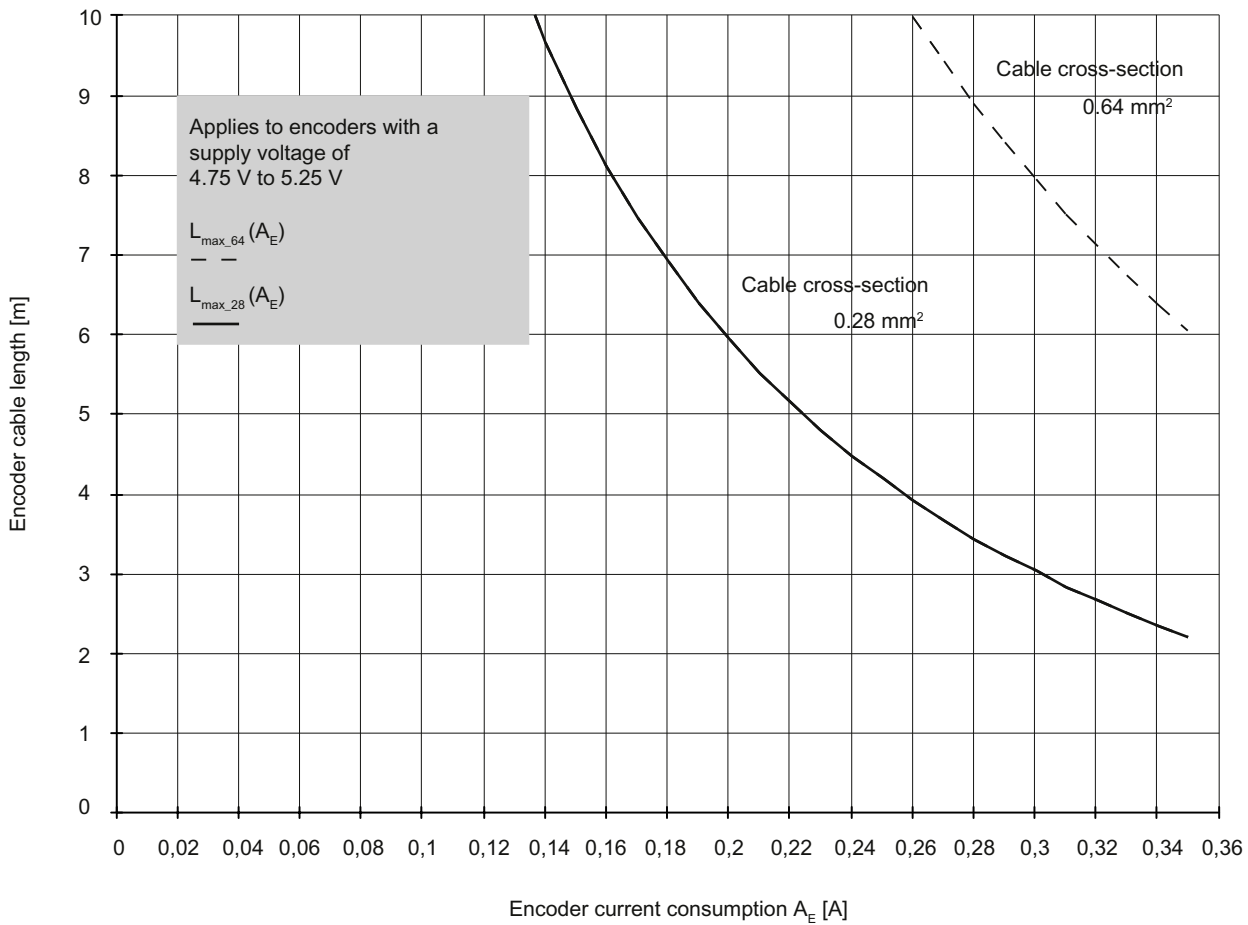

Figure 4-29 Max. cable length as a function of the current drawn by the encoder system

Besides the encoder systems for the supply voltage range of 4.75 V to 5.25 V in the figure above, encoder systems are also available for the extended range down to 3.6 V. These are generally operable using encoder system cables up to 10 m in length, provided that the total cross-section of the supply plus Remote Sense wires does not fall below 0.14 mm².

4.7 Sensor Module External SME25

4.7.1 Description

Direct encoder systems outside the cabinet can be connected to the Sensor Module External SME25. The SME25 evaluates these encoder systems and converts the calculated values to DRIVE-CLiQ.

Direct encoder systems with EnDat 2.1 or SSI (firmware version 2.4 or higher), which have SIN/COS (1 Vpp) incremental signals but not a reference signal, can be connected.

Neither motor nor encoder data are saved in the SME25.

The SME25 can be operated with firmware version 2.3 or higher.

4.7.2 Interface description

4.7.2.1 Overview

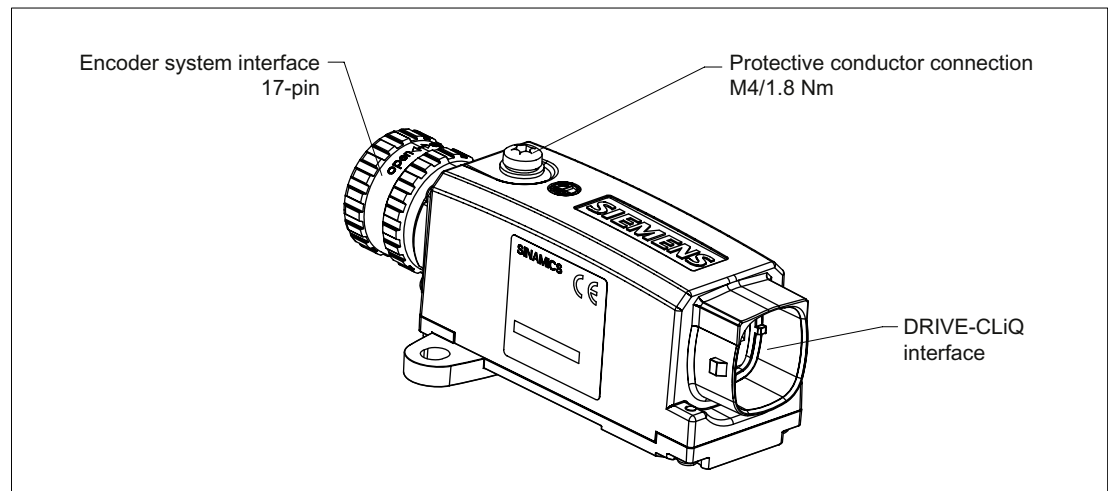

Figure 4-30 Interface description SME25

4.7.2.2 Connection example

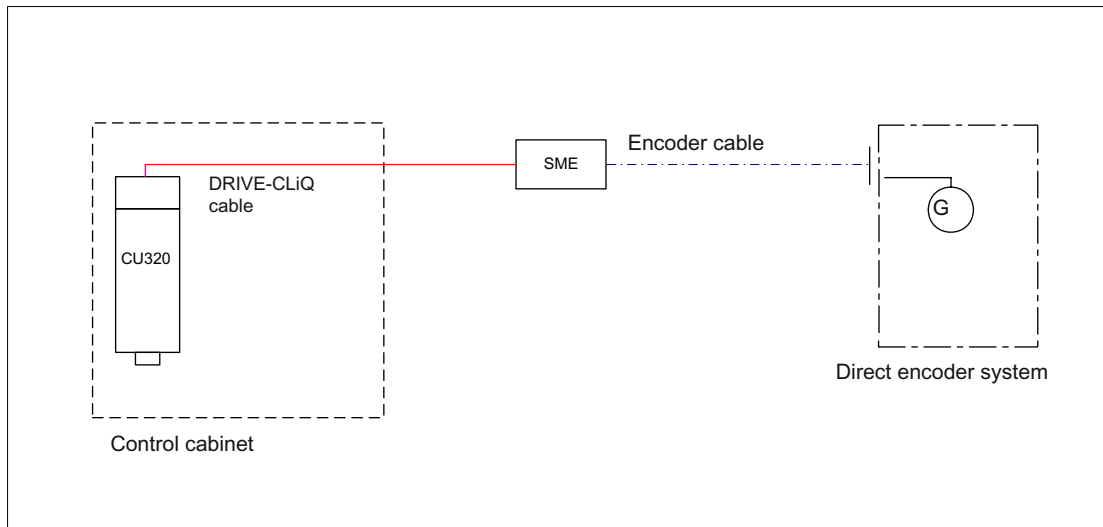

Figure 4-31 Connection of a direct encoder system via a Sensor Module External (SME)

4.7.2.3 DRIVE-CLiQ interface

Table 4- 25 DRIVE-CLiQ interface

	Pin	Signal name	Technical specifications
	1	TXP	Transmit data +
	2	TXN	Transmit data -
	3	RXP	Receive data +
	4	Reserved, do not use	
	5	Reserved, do not use	
	6	RXN	Receive data -
	7	Reserved, do not use	
	8	Reserved, do not use	
	A	+ (24 V)	Power supply
	B	M (0 V)	Electronics ground

Cover for the DRIVE-CLiQ interface is included in the scope of supply
 Current consumption: max. 0.25 A

Note

Only MOTION-CONNECT DRIVE-CLiQ cables may be used for connections. With MOTION-CONNECT 500, the maximum cable length is 100 m; with MOTION-CONNECT 800, it is 50 m.

4.7.2.4 Encoder system interface

Table 4- 26 Encoder system interface SME25

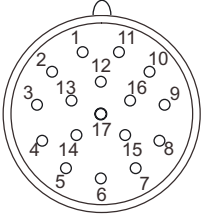
	Pin	Signal name	Technical specifications
	1	P5	Encoder power supply
	2	Reserved, do not use	
	3	Reserved, do not use	
	4	M	Ground for encoder power supply
	5	Reserved, do not use	
	6	Reserved, do not use	
	7	P5	Encoder power supply
	8	Clock	Clock, EnDat interface, SSI clock ¹⁾
	9	Clock*	Inverse clock, EnDat interface, Inverse SSI clock ¹⁾
	10	M	Ground for encoder power supply
	11	Housing potential	
	12	B	Incremental signal B
	13	B*	Inverse incremental signal B
	14	Data	Data, EnDat interface, SSI data ¹⁾
	15	A	Incremental signal A
	16	A*	Inverse incremental signal A
	17	Data*	Inverse data EnDat interface, Inverse SSI data ¹⁾
Blanking plate for encoder system interface: Pöppelmann GmbH & Co. KG, Lohne, Order No.: GPN 300 F211 connector kits, 17-pin, Order No.: 6FX2003-0SA17			

1) Only with firmware version 2.4 or higher

4.7.3 Dimension drawings

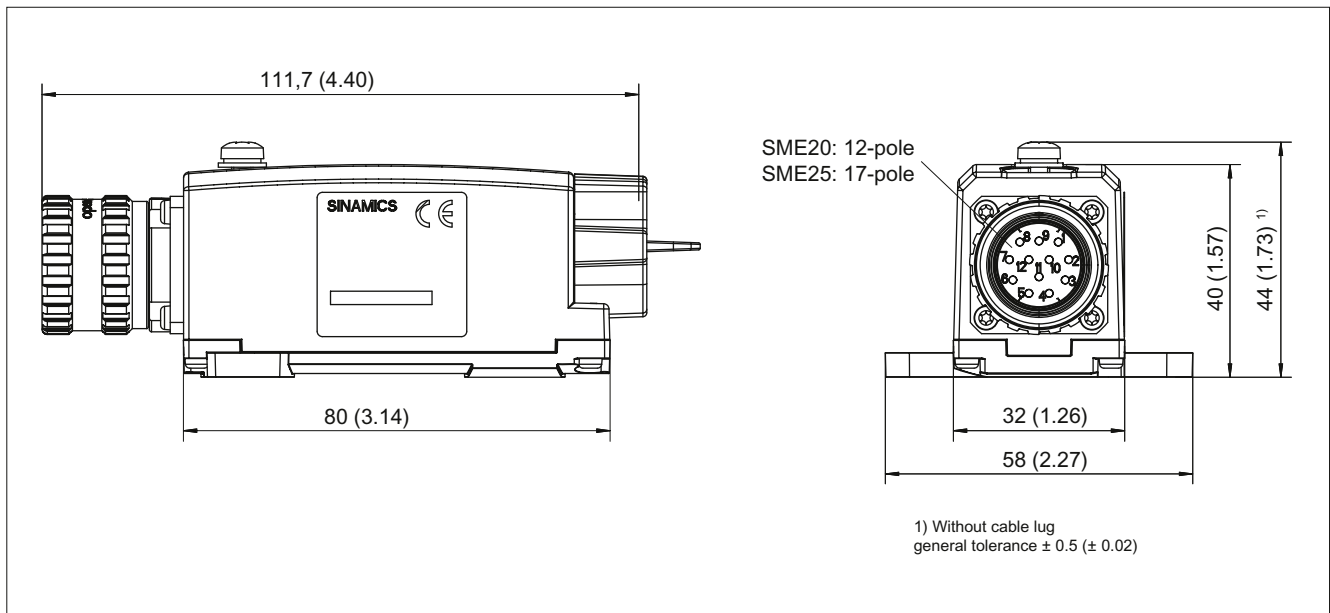

Figure 4-32 Dimension drawing of Sensor Module External SME25, all data in mm and (inches), order number 6SL3055-0AA00-5HA3

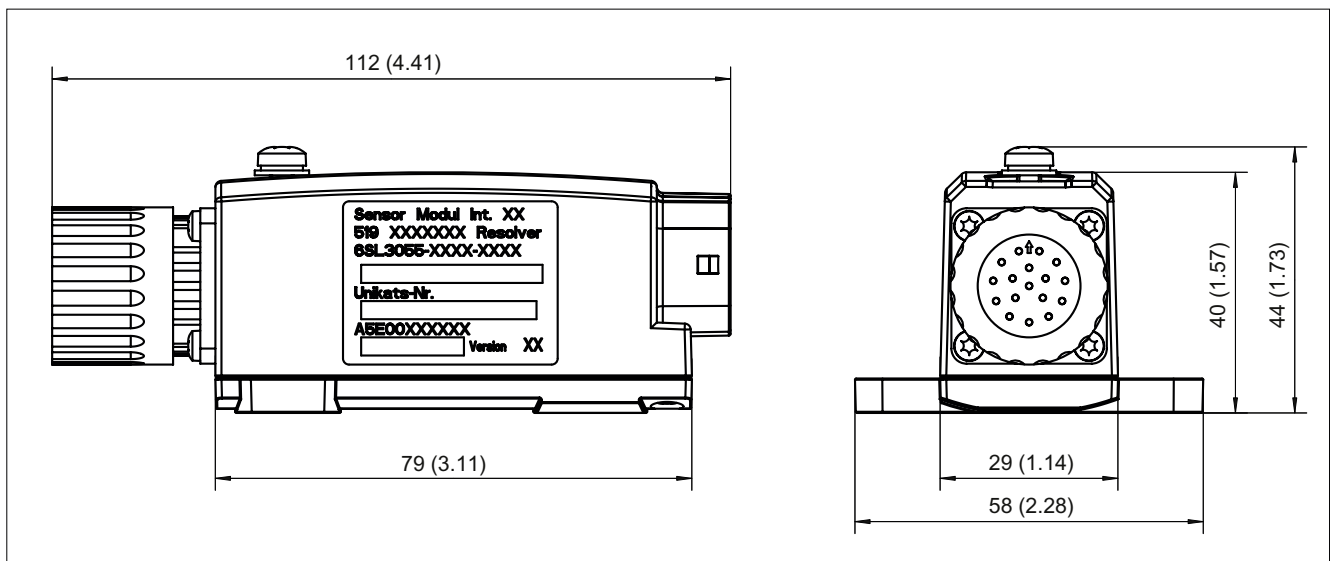

Figure 4-33 Dimension drawing of Sensor Module External SME25, all data in mm and (inches), order number 6SL3055-0AA00-5HA0

Note

Sensor Module External SME25 with order number 6SL3055-0AA00-5HA0 **cannot** be operated with version 4.x drive runtime software.

4.7.4 Installation

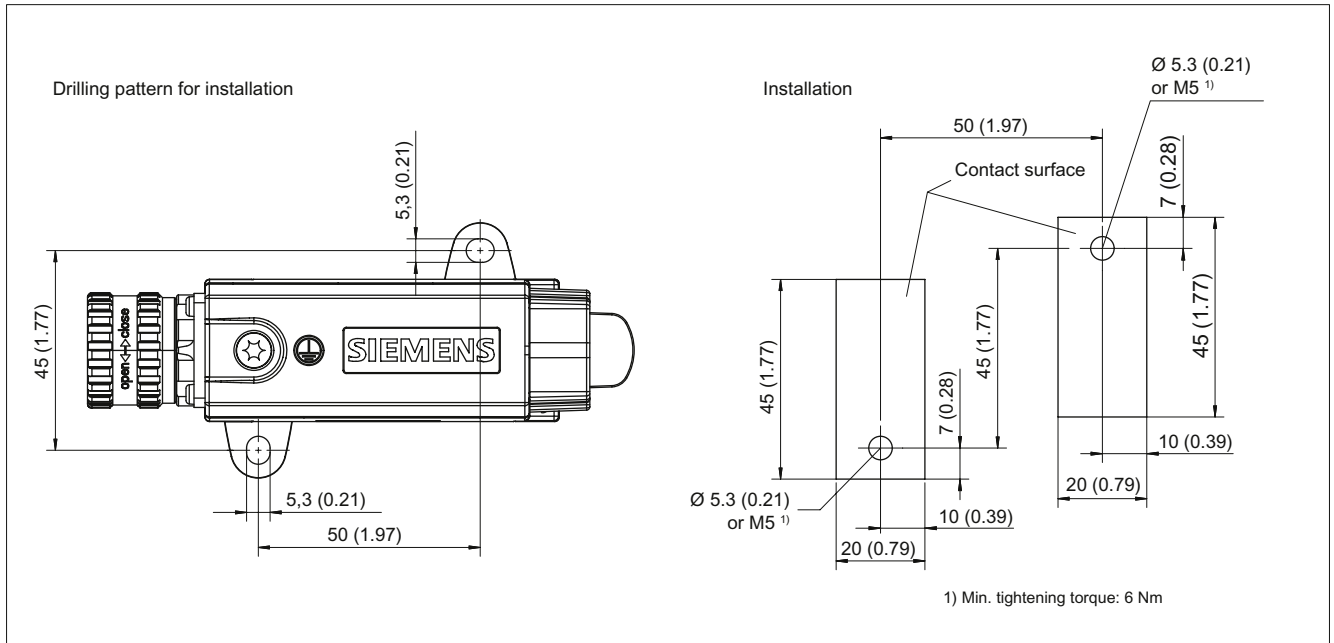

Figure 4-34 SME20/SME25 installation

Procedure

1. Place the drilling pattern on the bright contact surface
2. Holes Ø 5.3 or threads M5
3. Tighten with a min. torque of 6 Nm.

4.7.5 Technical data

Table 4- 27 Technical data

6SL3055-0AA00-5HAx	Unit	Value
Electronics power supply		
Voltage	V_{DC}	24 DC (20.4 – 28.8)
Current (without encoder system)	A_{DC}	≤ 0.15
Current (with encoder system)	A_{DC}	≤ 0.25
Power loss	W	≤ 4
Encoder system power supply		
Voltage	$V_{encoder}$	5 VDC
Current	$A_{encoder}$	0.35
Encoder frequency that can be evaluated ($f_{encoder}$)	kHz	≤ 500
SSI/EnDat 2.1 baud rate	kHz	100
PE/ground connection		On housing with M4/1.8 Nm screw
Weight	kg	0.18 (order number 6SL3055-0AA00-5HA0) 0.31 (order number 6SL3055-0AA00-5HA3)
Degree of protection		IP67

The maximum cable length for the encoder system interface depends on the current consumption of the encoder system and the cross-section of the wire in the cable. However, the maximum length is 10 m. The figure below applies to encoder systems that operate in the supply voltage range between 4.75 V and 5.25 V. The sample parameters shown are 0.28 mm² cross-section (0.14 mm² supply plus 0.14 mm² Remote Sense wires) and 0.64 mm² (0.5 mm² supply plus 0.14 mm² Remote Sense wires).

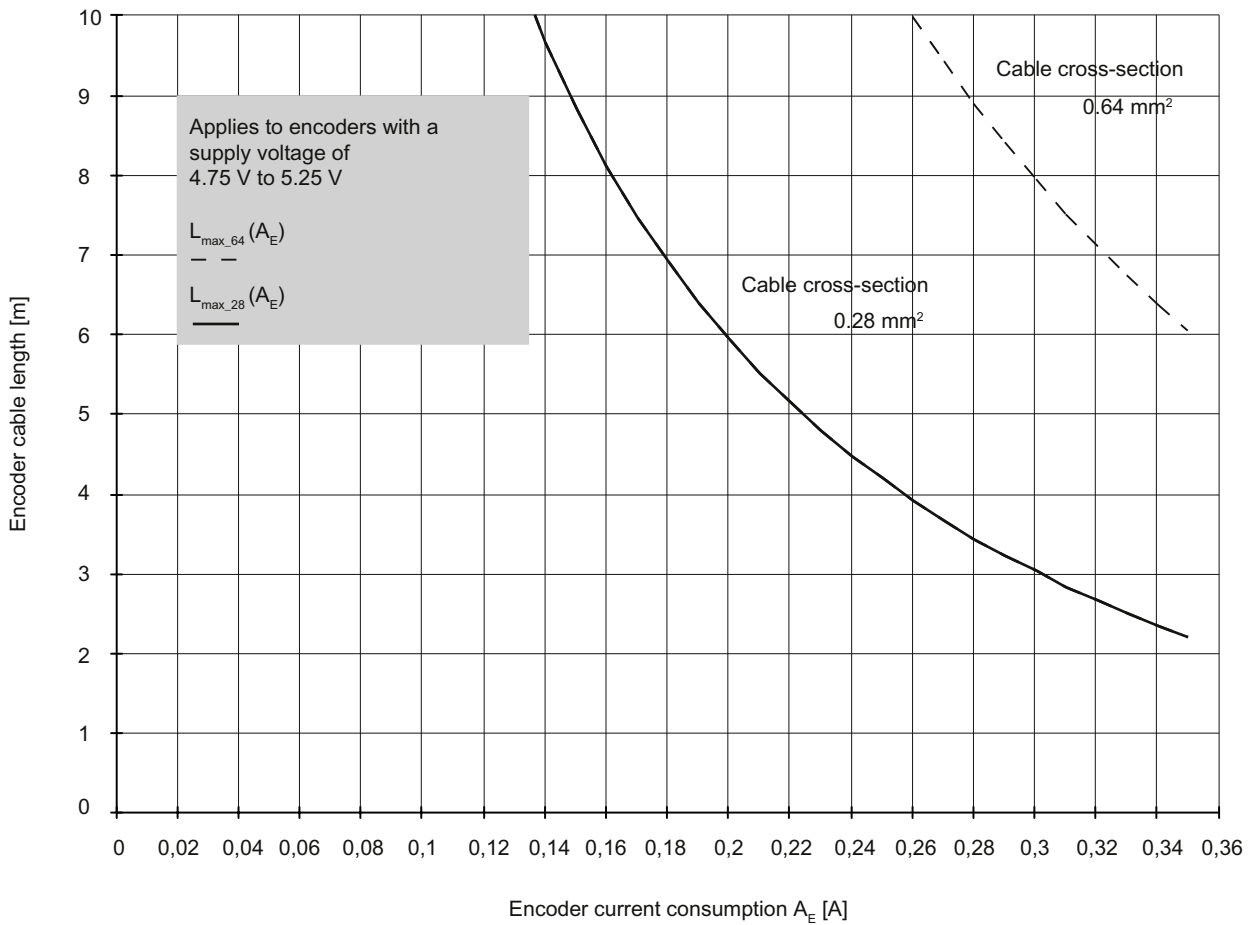

Figure 4-35 Max. cable length as a function of the current drawn by the encoder system

Besides the encoder systems for the supply voltage range of 4.75 V to 5.25 V in the figure above, encoder systems are also available for the extended range down to 3.6 V. These are generally operable using encoder system cables up to 10 m in length, provided that the total cross-section of the supply plus Remote Sense wires does not fall below 0.14 mm².

4.8 Sensor Module External SME120

4.8.1 Description

Direct encoder systems outside the cabinet can be connected to the Sensor Module External SME120. The SME120 evaluates these encoder systems and converts the calculated values to DRIVE-CLiQ.

The components are always used when the temperature signals of the motors do not have protective separation or where this separation is not possible for certain reasons. SME120 is mainly used in linear motor applications.

A Hall sensor box can be connected to determine the commutation position of a linear motor.

Incremental direct encoder systems with SIN/COS (1 Vpp) and reference signal can be connected.

Neither motor nor encoder data are saved in the SME120.

The SME120 can be operated with firmware version 2.4 or higher.

4.8.2 Safety information

Sensor Module External SME120 is a device of safety class I.

NOTICE

Only encoder systems in which the power supply for the encoder system is not grounded may be connected.

DANGER

All of the work must be carried out by qualified, appropriately trained personnel. Prior to commencing any work on the Sensor Module External the 5 safety rules have to be observed:

- Disconnect the system.
- Protect against reconnection.
- Make sure that the equipment is de-energized.
- Ground and short circuit.
- Cover or enclose adjacent components that are still live.

Never disable protective functions and devices even for trial operation.

It is mandatory that a protective conductor with a minimum cross-section of 2.5 mm² is connected in order to guarantee safe electrical separation.

In order to ensure the degree of protection, all connections, even connections that are not used, must be closed with connectors or suitable sealing caps.

The specified torques must be observed.

The plastic covers of connections X100, X200, and X500 do not comply with the degree of protection and must be replaced by the corresponding connectors prior to commissioning.

It is not permitted to open up the devices! This may result in the units no longer being adequately sealed! Repair and maintenance work may only be performed by a SIEMENS service center.

The unit should not be put into operation if it is evident that the packaging has been damaged by water.

4.8.3 Interface description

4.8.3.1 Overview

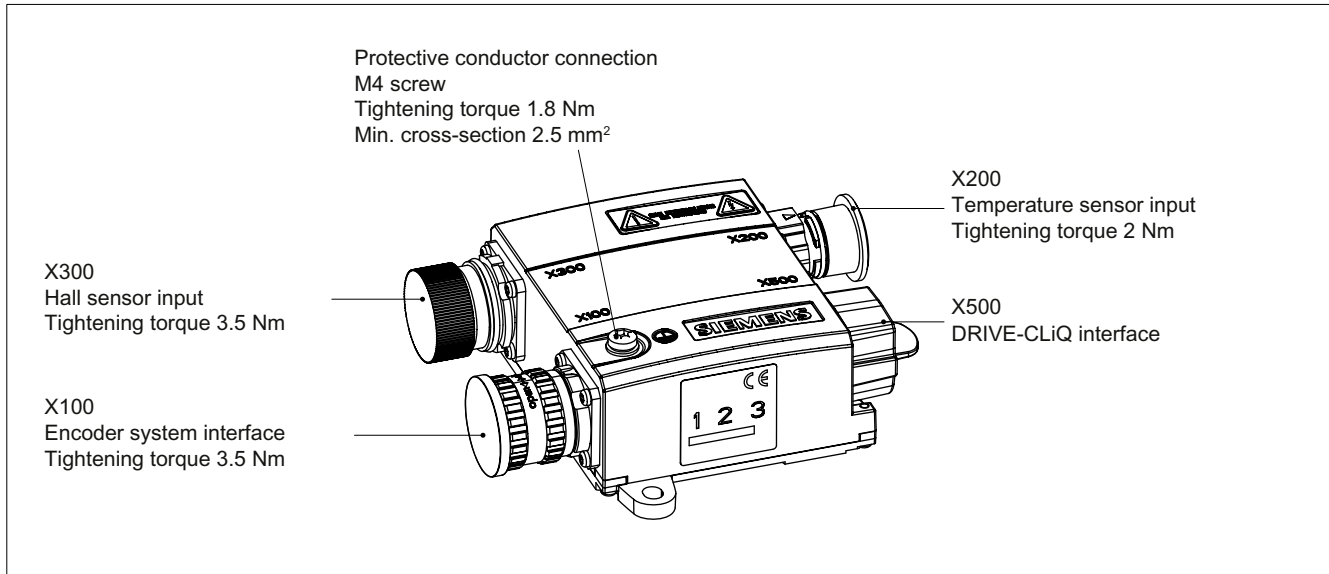

Figure 4-36 Interface description, SME120

4.8.3.2 Connection examples

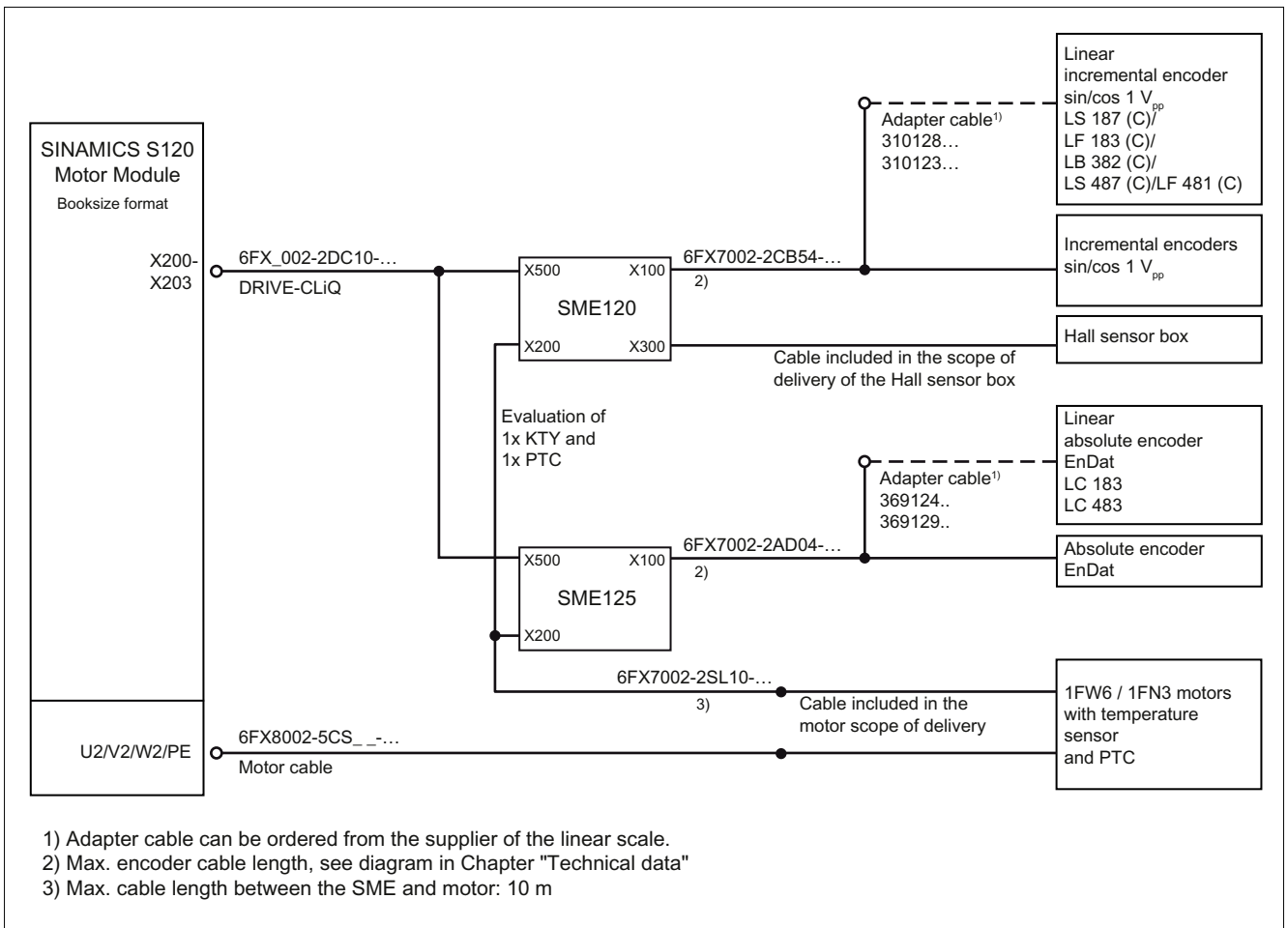

Figure 4-37 Connecting motor encoders via SME for motors without a DRIVE-CLiQ interface and molded connecting cables with terminated cable ends

4.8 Sensor Module External SME120

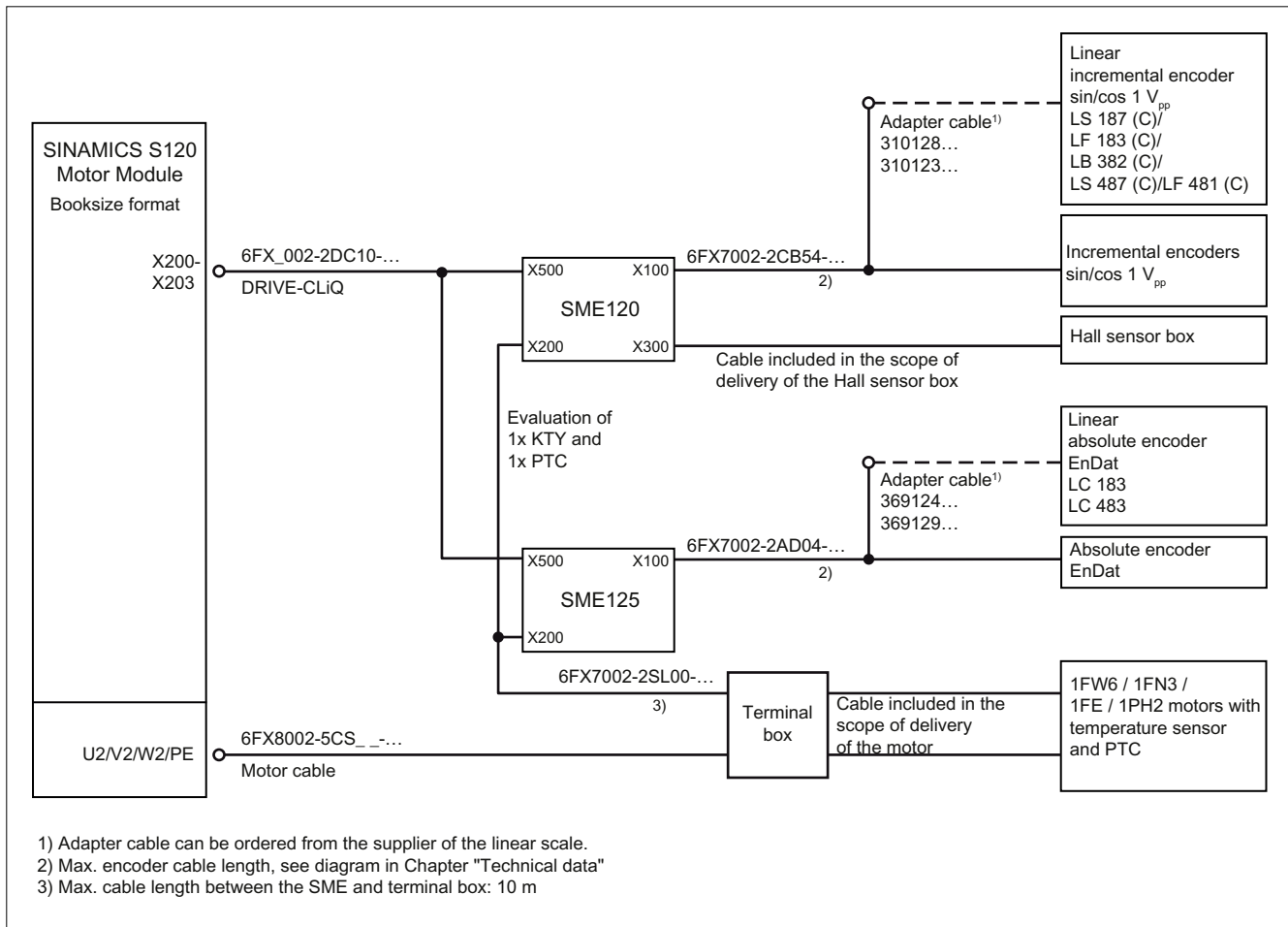

Figure 4-38 Connecting motor encoders via SME for motors without a DRIVE-CLiQ interface and molded connecting cables with open cable ends

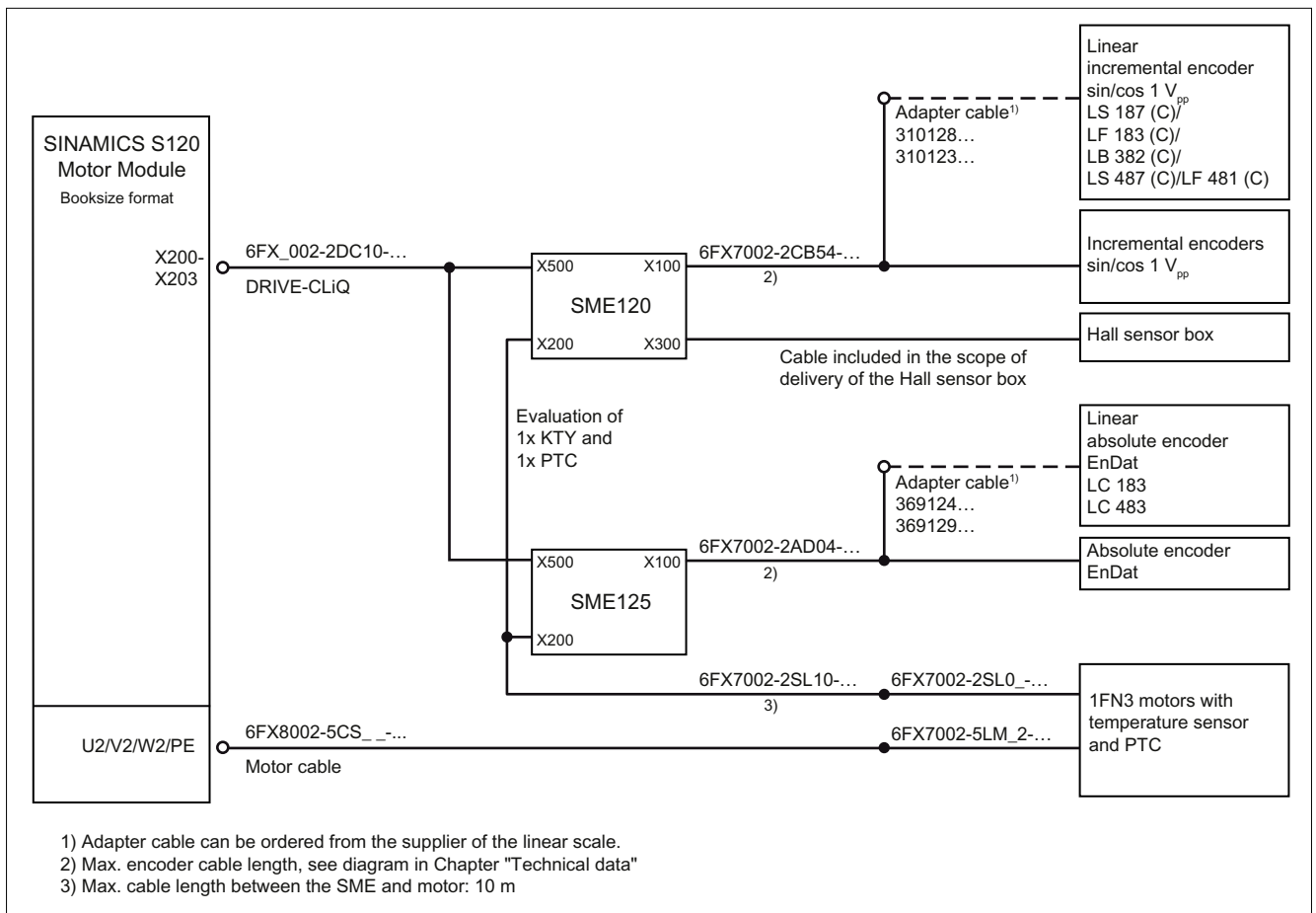

Figure 4-39 Connecting motor encoders via SME for motors without a DRIVE-CLiQ interface, with an integrated 2-hole terminal box

Connection examples for motors connected in parallel

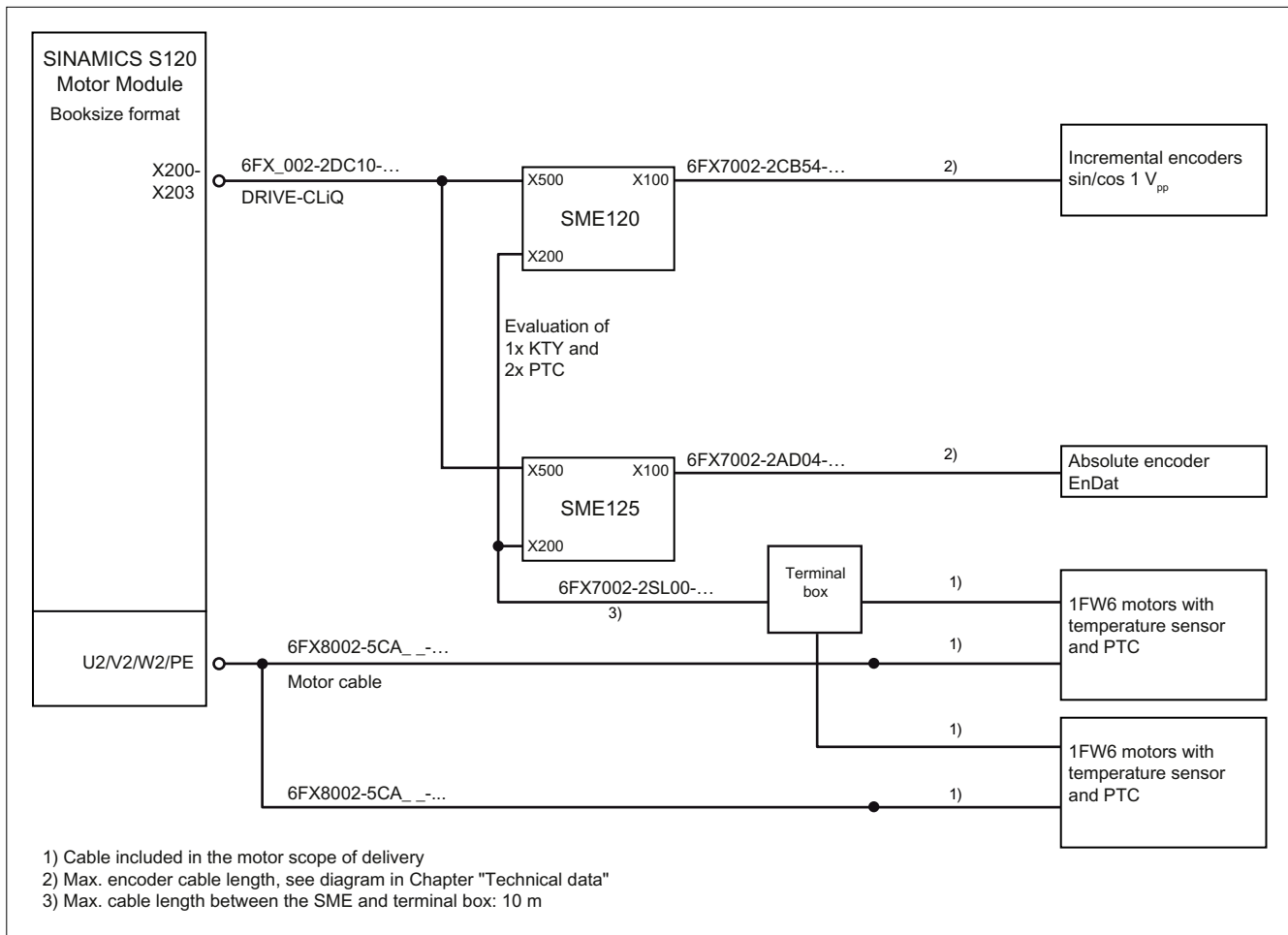

Figure 4-40 Connecting motor encoders via SME for torque motors connected in parallel without a DRIVE-CLiQ interface

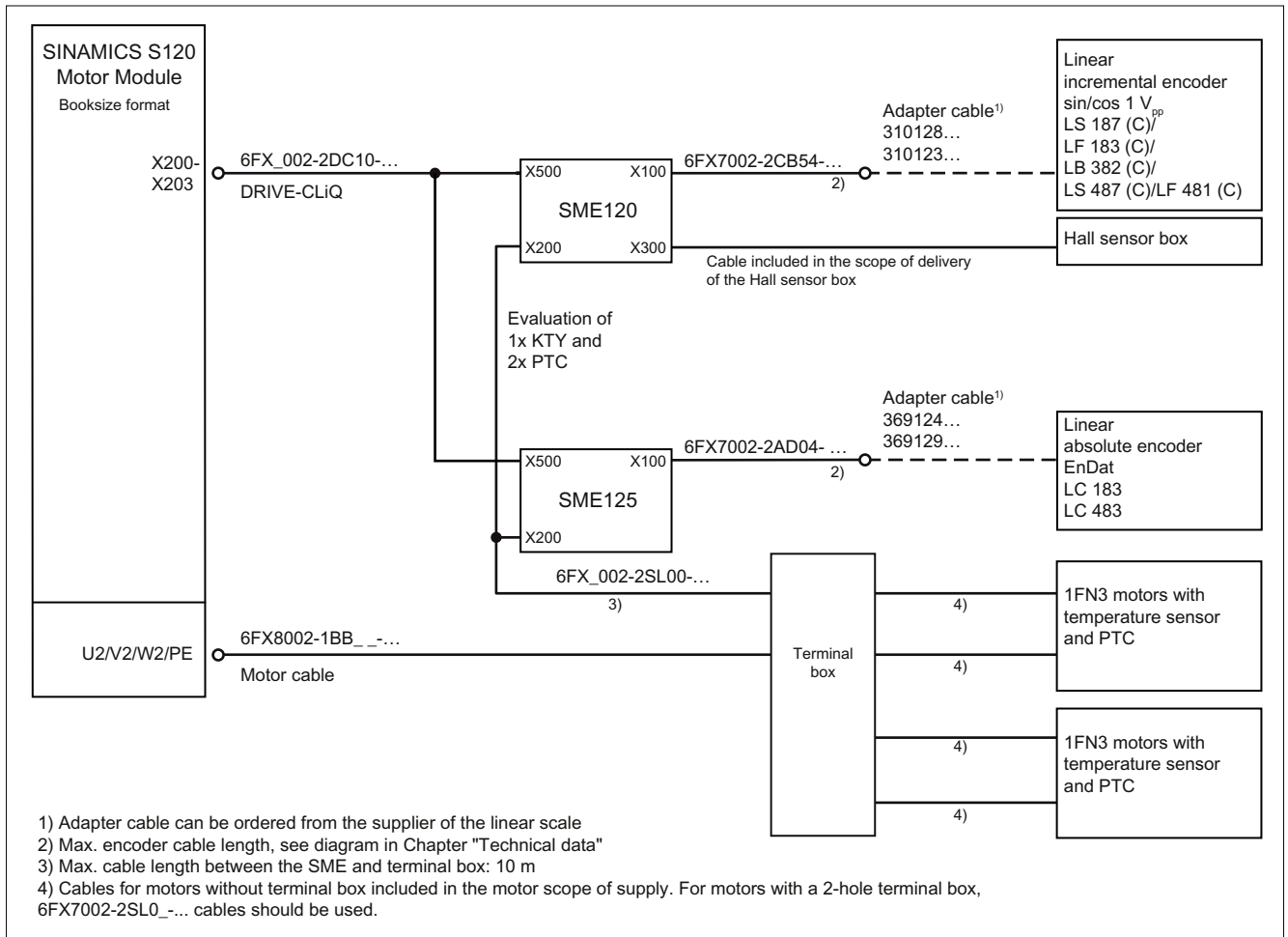
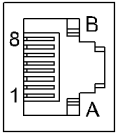

Figure 4-41 Connecting motor encoders via SME for linear motors connected in parallel without a DRIVE-CLiQ interface

4.8.3.3 X500 DRIVE-CLiQ interface

Table 4- 28 DRIVE-CLiQ interface

	Pin	Signal name	Technical specifications
	1	TXP	Transmit data +
	2	TXN	Transmit data -
	3	RXP	Receive data +
	4	Reserved, do not use	
	5	Reserved, do not use	
	6	RXN	Receive data -
	7	Reserved, do not use	
	8	Reserved, do not use	
	A	+ (24 V)	Power supply
	B	M (0 V)	Electronics ground

Cover for the DRIVE-CLiQ interface is included in the scope of supply
 Current consumption: max. 0.30 A

Note

Only MOTION-CONNECT DRIVE-CLiQ cables may be used for connections. With MOTION-CONNECT 500, the maximum cable length is 100 m; with MOTION-CONNECT 800, it is 50 m.

4.8.3.4 X100 encoder system interface

Table 4- 29 Encoder system interface SME120

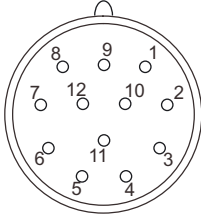
	Pin	Signal name	Technical specifications
	1	B*	Inverse incremental signal B
	2	P5	Encoder power supply
	3	R	Reference signal R
	4	R*	Inverse reference signal R
	5	A	Incremental signal A
	6	A*	Inverse incremental signal A
	7	Reserved, do not use	
	8	B	Incremental signal B
	9	Reserved, do not use	
	10	M	Ground for encoder power supply
	11	M	Ground for encoder power supply
	12	P5	Encoder power supply

Blanking plate for encoder system interface: Pöppelmann GmbH & Co. KG, Lohne,
 Order No.: GPN 300 F211
 connector kits, 12-pole, Order No.: 6FX2003-0SA12

4.8.3.5 X200 thermistor sensor input

Table 4- 30 X200 thermistor sensor input

Pin	Function	Technical specifications
1	-Temp	Temperature sensor connection KTY84-1C130/PTC/bimetallic switch with NC contact In linear and torque motor applications, connect the KTY84-1C130 motor temperature sensor here
2	+Temp	
3	+Temp	Temperature sensor connection KTY84-1C130/PTC/bimetallic switch with NC contact In linear and torque motor applications, connect the PTC triple element 1 or bimetallic switch here
4	-Temp	
5	+Temp	Temperature sensor connection KTY84-1C130/PTC/bimetallic switch with NC contact In torque motor applications, connect the PTC triple element 2 here
6	-Temp	
Connector kits, 6+1-pin, order number: 6FX2003-0SU07		

NOTICE

When connecting several temperature sensors, the individual sensors must be separately connected to "+ Temp" and "- Temp".

It is not permissible that the "+ Temp" and "- Temp" signals are interconnected with one another!

4.8.3.6 X300 Hall sensor input

Table 4- 31 Hall sensor input X300

Pin	Signal name	Technical specifications
1	C	Absolute track signal C
2	C*	Inverse absolute track signal C
3	P5	Encoder power supply
4	M	Ground for encoder power supply
5	D	Absolute track signal D
6	D*	Inverse absolute track signal D
7	Not assigned	
8	Not assigned	
9	Ground	Ground (for internal shield)

4.8.4 Dimension drawings

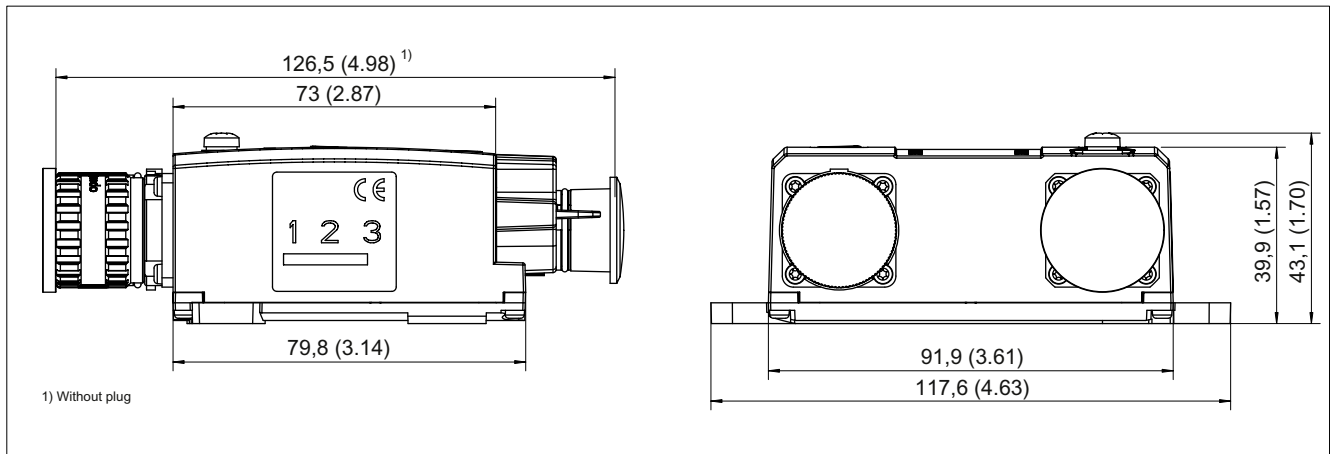

Figure 4-42 Dimension drawing of Sensor Module External SME120, all data in mm and (inches) order number 6SL3055-0AA00-5JA3

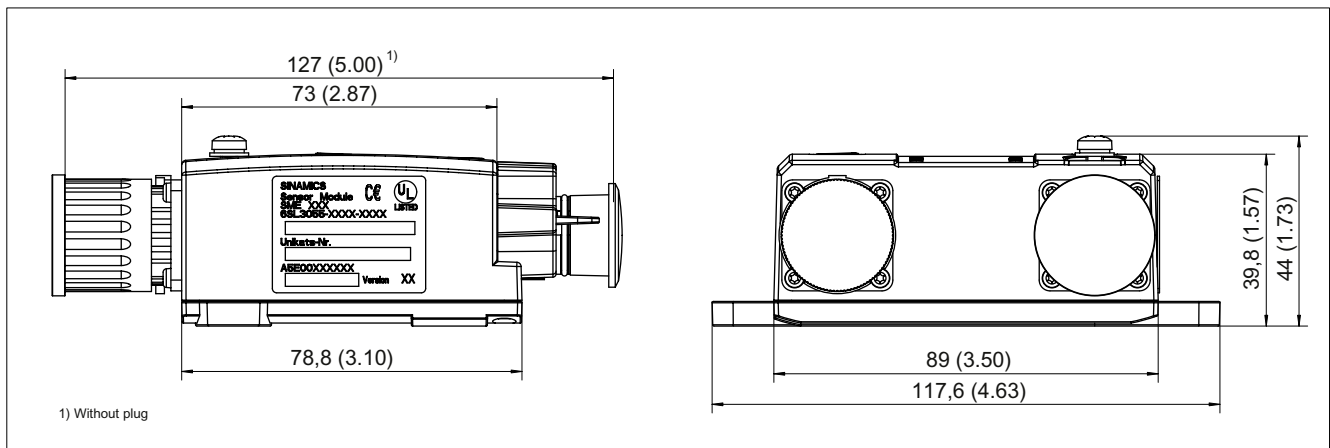

Figure 4-43 Dimension drawing of Sensor Module External SME120, all data in mm and (inches) order number 6SL3055-0AA00-5JA0

4.8.5 Installation

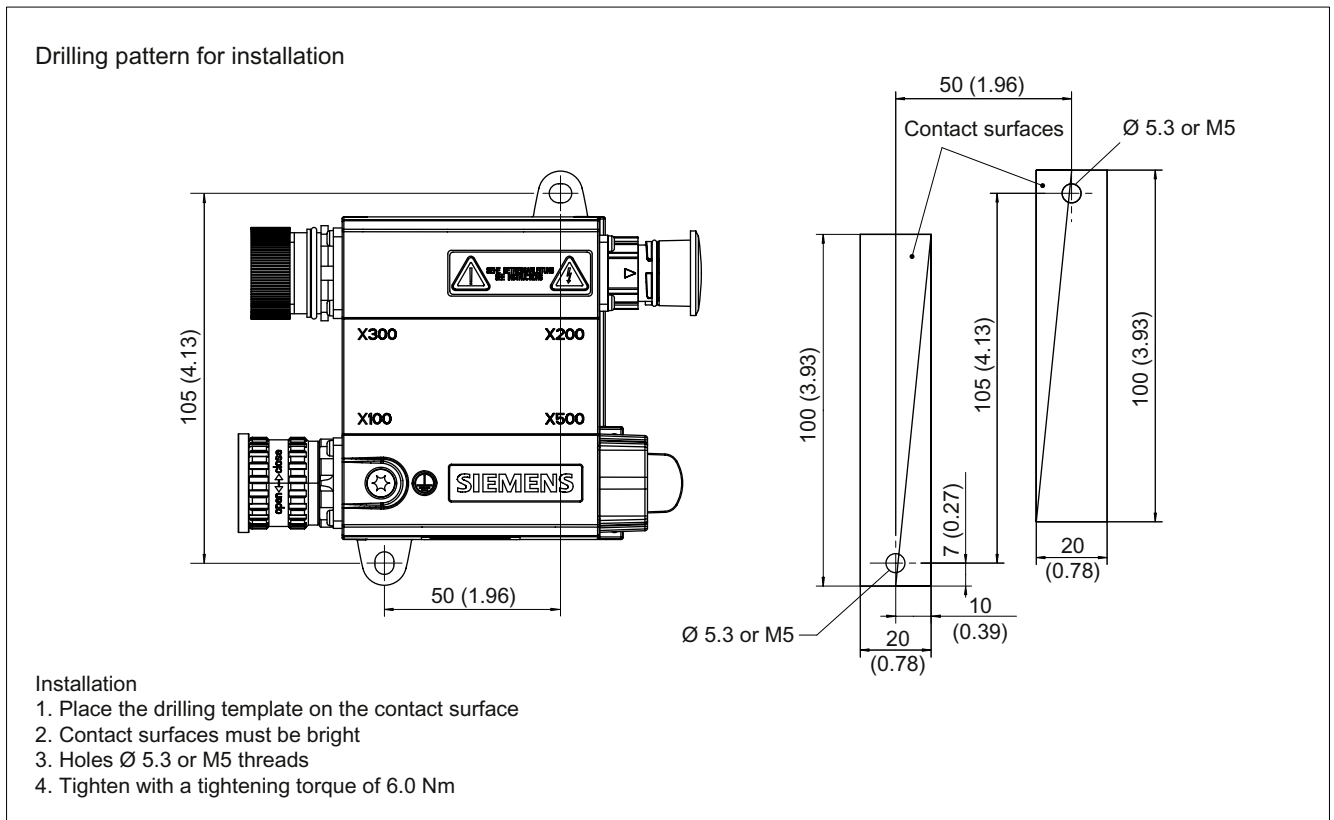

Figure 4-44 SME120 installation

4.8.6 Technical data

Table 4- 32 Technical data

6SL3055-0AA00-5JAx	Unit	Value
Electronics power supply		
Voltage	V_{DC}	24 DC (20.4 – 28.8)
Current (without encoder system)	A_{DC}	≤ 0.20
Current (with encoder system)	A_{DC}	≤ 0.30
Power loss	W	≤ 4.5
Encoder system power supply		
Voltage	$V_{encoder}$	5 VDC
Current	$A_{encoder}$	0.35
Encoder frequency that can be evaluated ($f_{encoder}$)	kHz	≤ 500
PE/ground connection		On housing with M4/1.8 Nm screw
Weight	kg	0.4 (order number 6SL3055-0AA00-5JA0) 0.7 (order number 6SL3055-0AA00-5JA3)
Degree of protection		IP67

NOTICE

In order to guarantee the degree of protection, all of the plug connectors must be correctly screwed into place and appropriately locked.

The maximum cable length for the encoder system interface depends on the current consumption of the encoder system and the cross-section of the wire in the cable. However, the maximum length is 10 m. The figure below applies to encoder systems that operate in the supply voltage range between 4.75 V and 5.25 V. The sample parameters shown are 0.28 mm² cross-section (0.14 mm² supply plus 0.14 mm² Remote Sense wires) and 0.64 mm² (0.5 mm² supply plus 0.14 mm² Remote Sense wires).

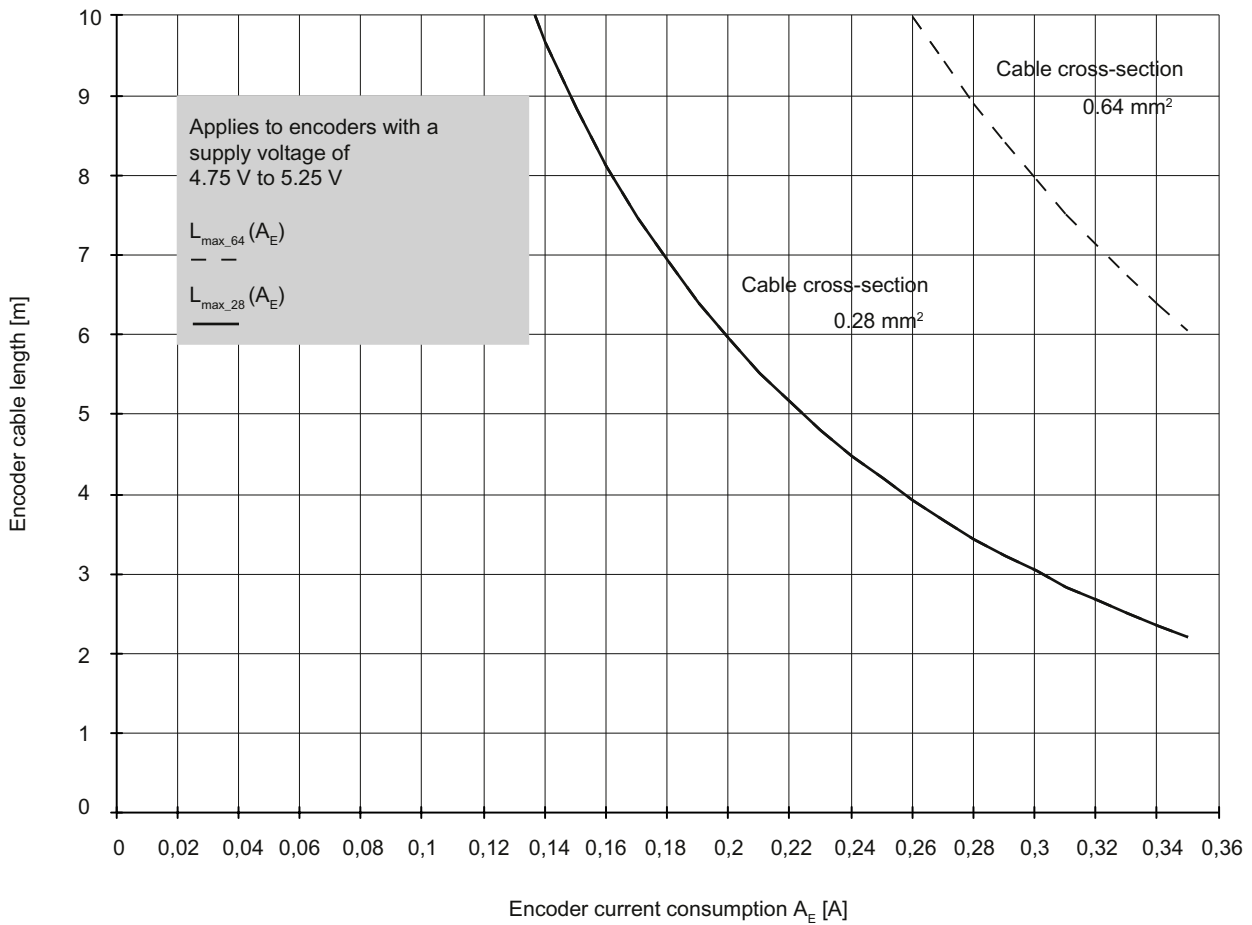

Figure 4-45 Max. cable length as a function of the current drawn by the encoder system

Besides the encoder systems for the supply voltage range of 4.75 V to 5.25 V in the figure above, encoder systems are also available for the extended range down to 3.6 V. These are generally operable using encoder system cables up to 10 m in length, provided that the total cross-section of the supply plus Remote Sense wires does not fall below 0.14 mm².

4.9 Sensor Module External SME125

4.9.1 Description

Direct encoder systems outside the cabinet can be connected to the Sensor Module External SME125. The SME125 evaluates these encoder systems and converts the calculated values to DRIVE-CLiQ.

The components are always used when the temperature signals of the motors do not have protective separation or where this separation is not possible for certain reasons. SME125 is mainly used in linear motor applications.

Direct encoder systems with EnDat 2.1 or SSI with SIN/COS (1 Vpp) incremental signals can be connected, however without reference signal.

Neither motor nor encoder data are saved in the SME125.

The SME125 can be operated with firmware version 2.4 or higher.

4.9.2 Safety information

Sensor Module External SME125 is a device of safety class I.

NOTICE
Only encoder systems in which the power supply for the encoder system is not grounded may be connected.

 DANGER
All of the work must be carried out by qualified, appropriately trained personnel. Prior to commencing any work on the Sensor Module External the 5 safety rules have to be observed: <ul style="list-style-type: none">• Disconnect the system.• Protect against reconnection.• Make sure that the equipment is de-energized.• Ground and short circuit.• Cover or enclose adjacent components that are still live. Never disable protective functions and devices even for trial operation. It is mandatory that a protective conductor with a minimum cross-section of 2.5 mm ² is connected in order to guarantee safe electrical separation. In order to ensure the degree of protection, all connections, even connections that are not used, must be closed with connectors or suitable sealing caps. The specified torques must be observed. The plastic covers of connections X100, X200, and X500 do not comply with the degree of protection and must be replaced by the corresponding connectors prior to commissioning. It is not permitted to open up the devices! This may result in the units no longer being adequately sealed! Repair and maintenance work may only be performed by a SIEMENS service center. The unit should not be put into operation if it is evident that the packaging has been damaged by water.

Note

The safety information on the Sensor Module must be observed.

After the product has served its lifetime, the individual parts should be disposed of in compliance with local regulations.

4.9.3 Interface description

4.9.3.1 Overview

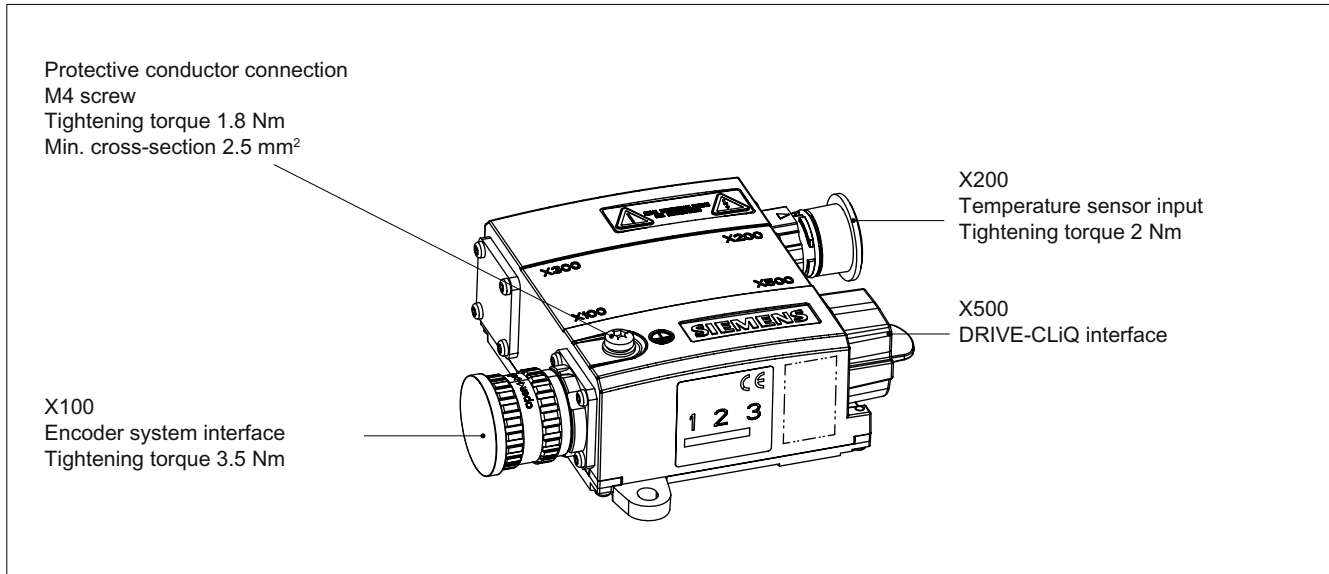

Figure 4-46 Interface description, SME125

4.9.3.2 Connection examples

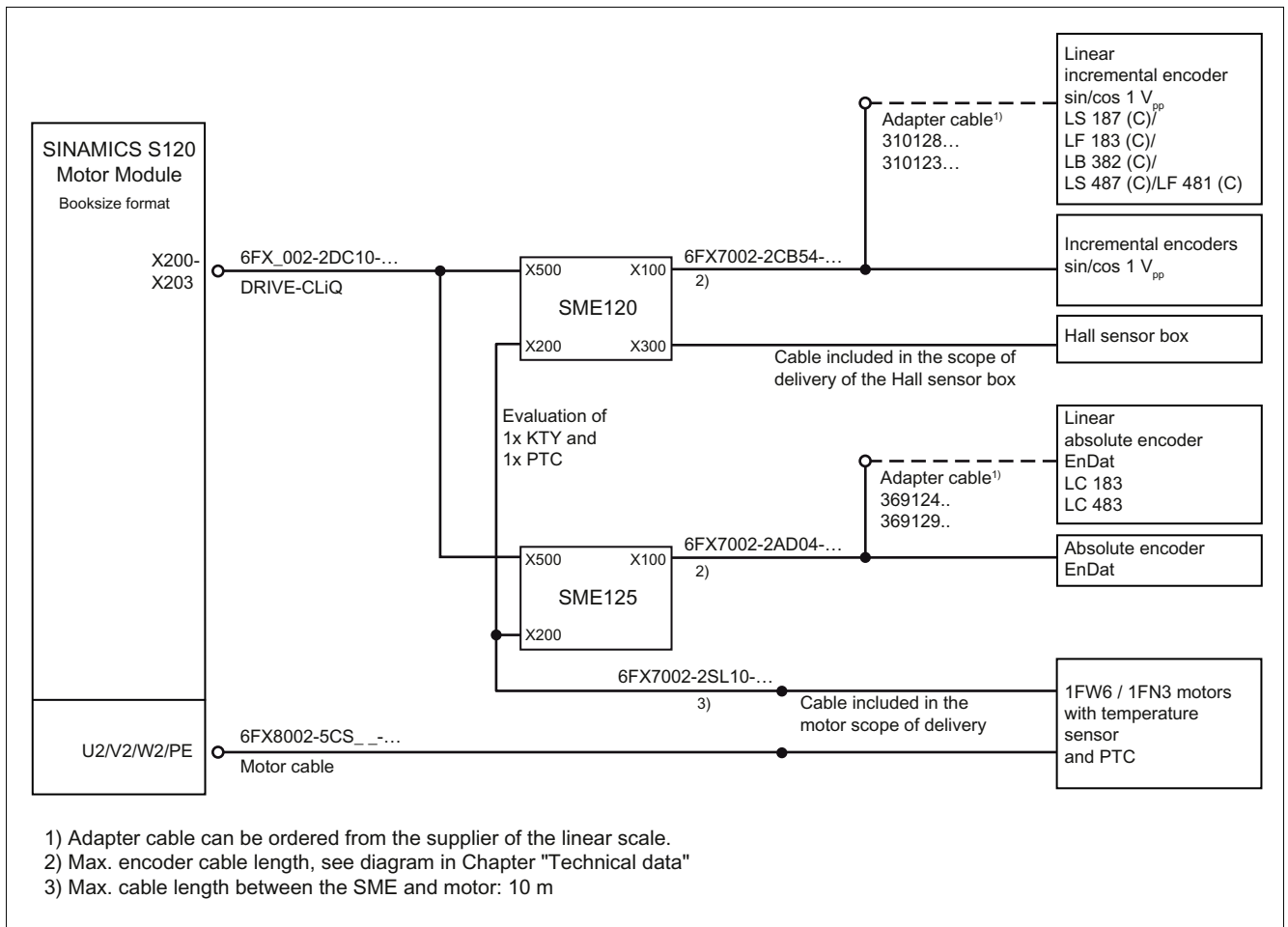

Figure 4-47 Connecting motor encoders via SME for motors without a DRIVE-CLiQ interface and molded connecting cables with terminated cable ends

4.9 Sensor Module External SME125

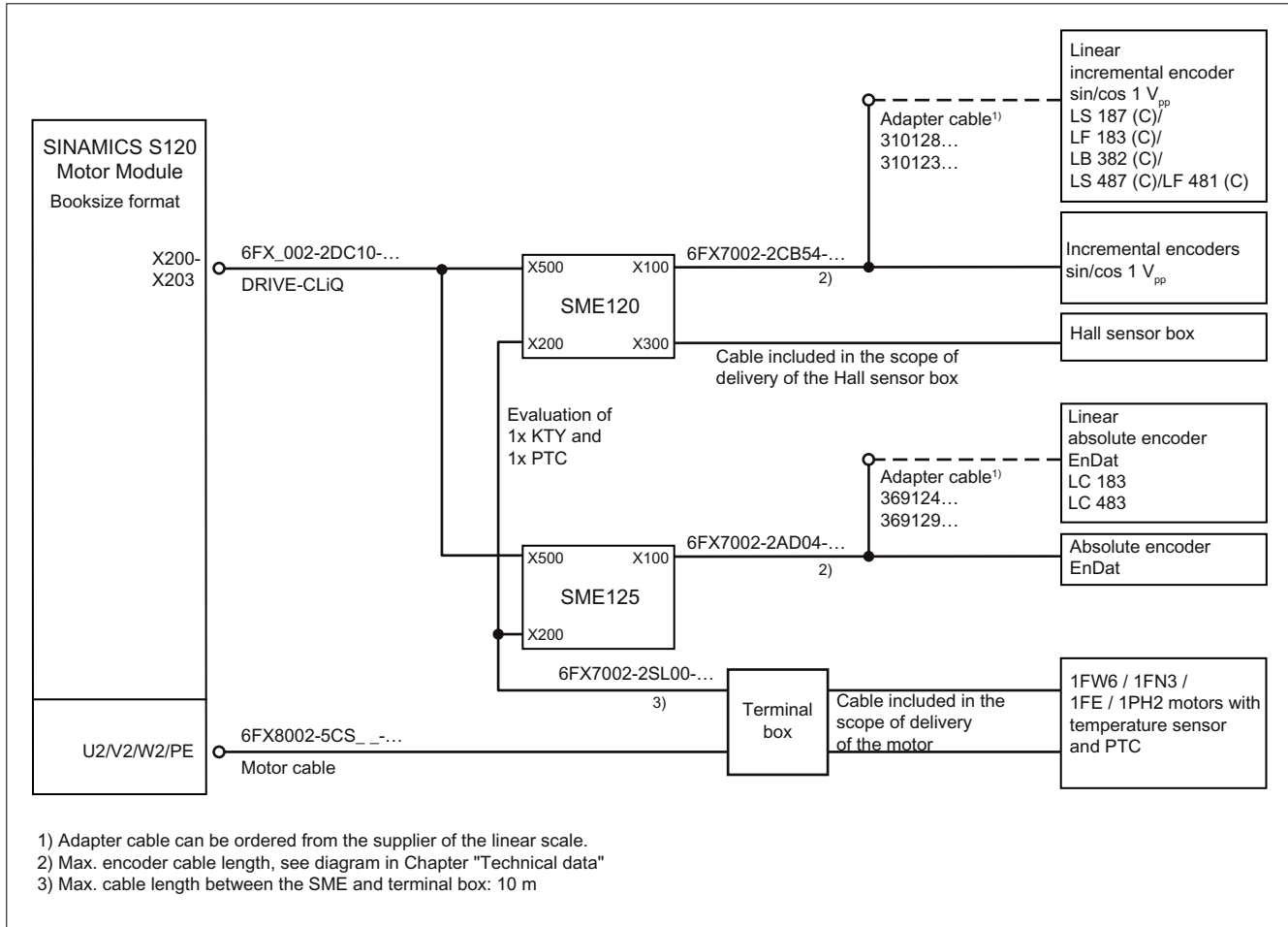

Figure 4-48 Connecting motor encoders via SME for motors without a DRIVE-CLiQ interface and molded connecting cables with open cable ends

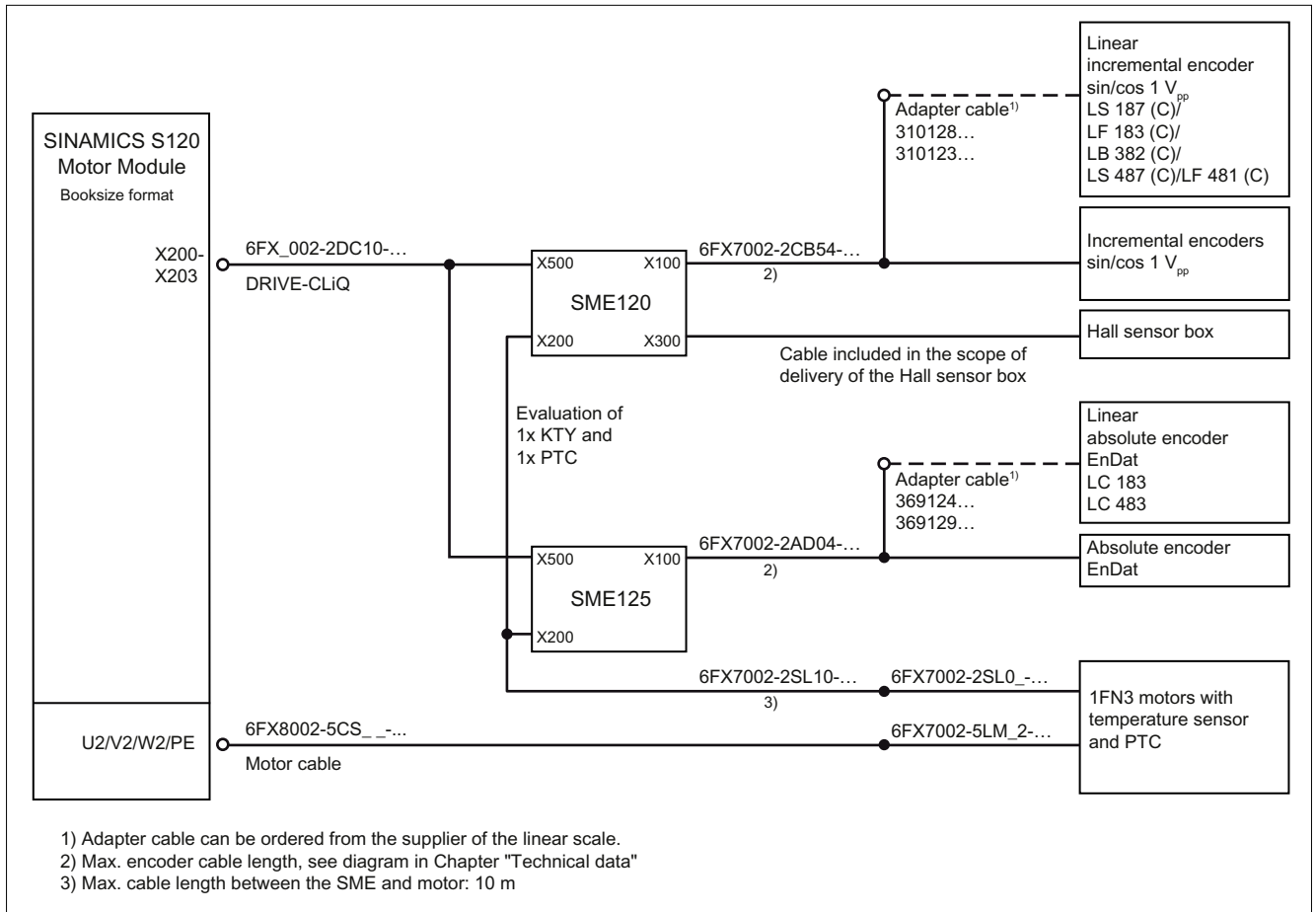

Figure 4-49 Connecting motor encoders via SME for motors without a DRIVE-CLiQ interface, with an integrated 2-hole terminal box

Connection examples for motors connected in parallel

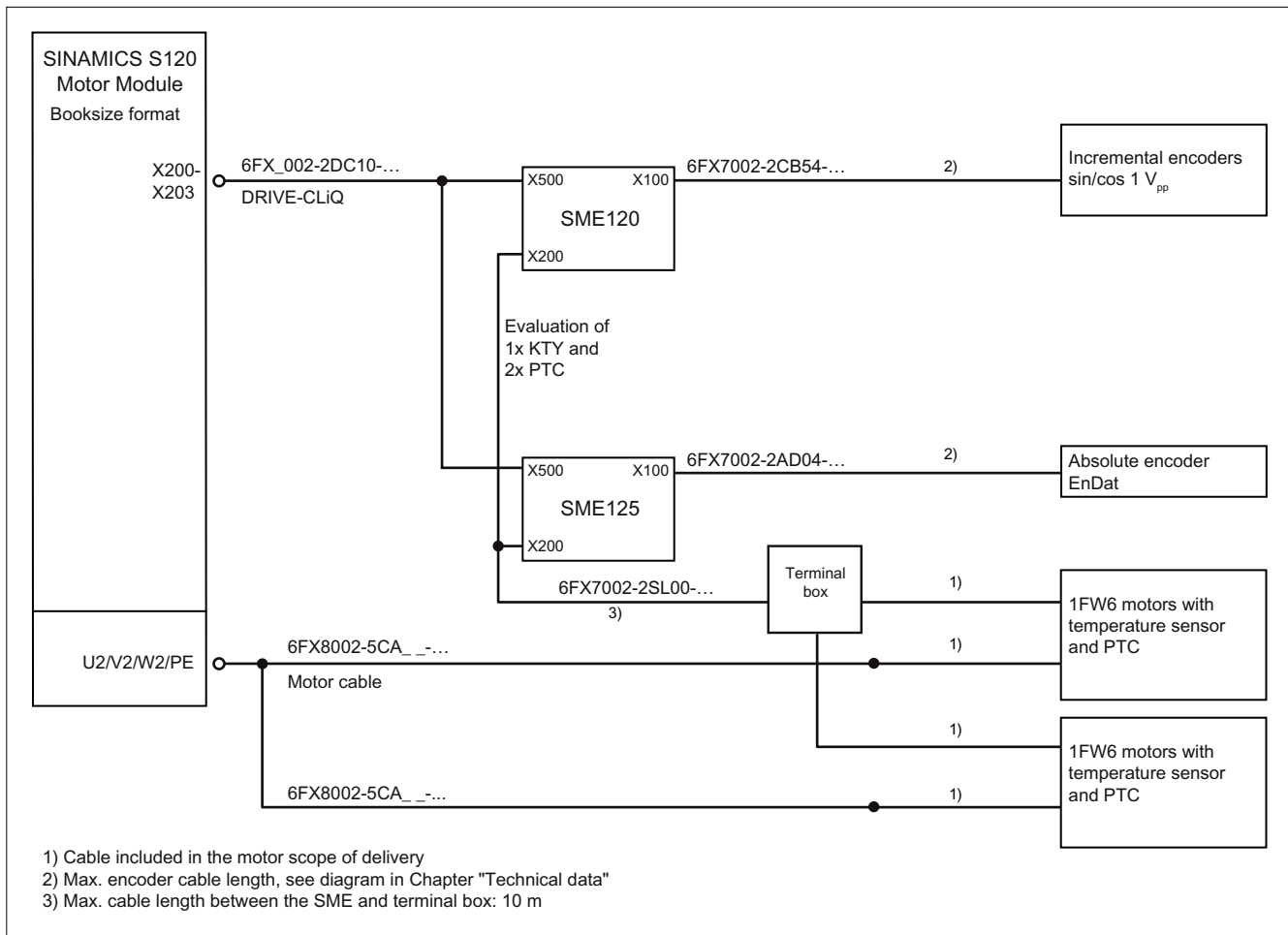

Figure 4-50 Connecting motor encoders via SME for torque motors connected in parallel without a DRIVE-CLiQ interface

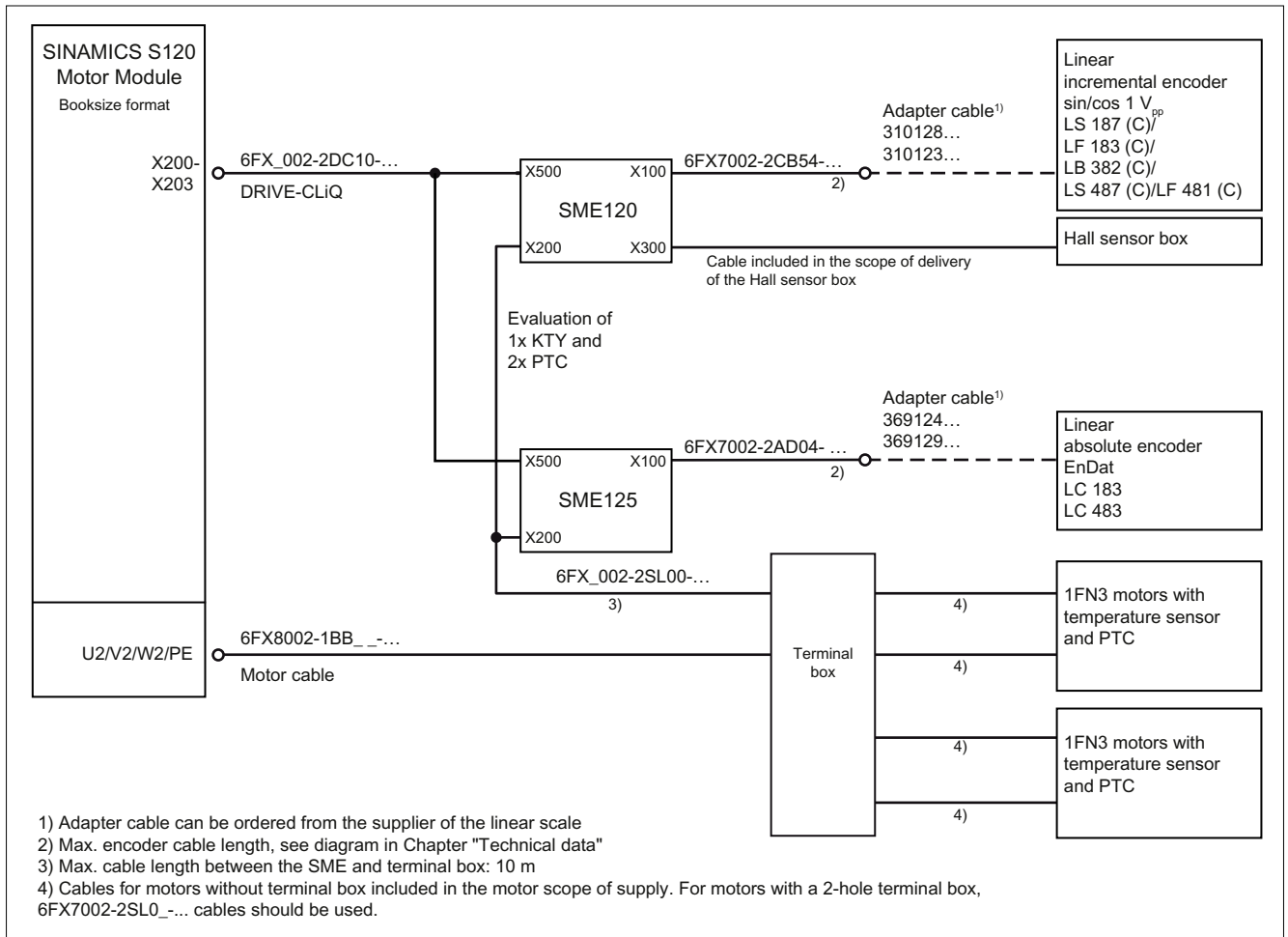
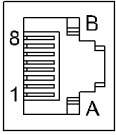

Figure 4-51 Connecting motor encoders via SME for linear motors connected in parallel without a DRIVE-CLiQ interface

4.9.3.3 X500 DRIVE-CLiQ interface

Table 4- 33 DRIVE-CLiQ interface

	Pin	Signal name	Technical specifications
	1	TXP	Transmit data +
	2	TXN	Transmit data -
	3	RXP	Receive data +
	4	Reserved, do not use	
	5	Reserved, do not use	
	6	RXN	Receive data -
	7	Reserved, do not use	
	8	Reserved, do not use	
	A	+ (24 V)	Power supply
	B	M (0 V)	Electronics ground
	Cover for the DRIVE-CLiQ interface is included in the scope of supply Current consumption: max. 0.30 A		

Note

Only MOTION-CONNECT DRIVE-CLiQ cables may be used for connections. With MOTION-CONNECT 500, the maximum cable length is 100 m; with MOTION-CONNECT 800, it is 50 m.

4.9.3.4 X100 encoder system interface

Table 4- 34 Encoder system interface SME125

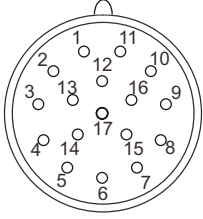
	Pin	Signal name	Technical specifications
	1	P5	Encoder power supply
	2	Reserved, do not use	
	3	Reserved, do not use	
	4	M	Ground for encoder power supply
	5	Reserved, do not use	
	6	Reserved, do not use	
	7	P5	Encoder power supply
	8	Clock	Clock, EnDat interface, SSI clock
	9	Clock*	Inverse clock EnDat interface Inverse SSI clock
	10	M	Ground for encoder power supply
	11	Housing potential	
	12	B	Incremental signal B
	13	B*	Inverse incremental signal B
	14	Data	Data, EnDat interface, SSI data
	15	A	Incremental signal A
	16	A*	Inverse incremental signal A
	17	Data*	Inverse data, EnDat interface, Inverse SSI data
Blanking plate for encoder system interface: Pöppelmann GmbH & Co. KG, Lohne, Order No.: GPN 300 F211 connector kits, 17-pin, Order No.: 6FX2003-0SA17			

* These connections do not have safe separation!

4.9.3.5 X200 thermistor sensor input

Table 4- 35 X200 thermistor sensor input

Pin	Function	Technical specifications
1	-Temp	Temperature sensor connection KTY84-1C130/PTC/bimetallic switch with NC contact In linear and torque motor applications, connect the KTY84-1C130 motor temperature sensor here
2	+Temp	
3	+Temp	Temperature sensor connection KTY84-1C130/PTC/bimetallic switch with NC contact In linear and torque motor applications, connect the PTC triple element 1 or bimetallic switch here
4	-Temp	
5	+Temp	Temperature sensor connection KTY84-1C130/PTC/bimetallic switch with NC contact In torque motor applications, connect the PTC triple element 2 here
6	-Temp	

Connector kits, 6+1-pin, order number: 6FX2003-0SU07

NOTICE

When connecting several temperature sensors, the individual sensors must be separately connected to "+ Temp" and "- Temp".

It is not permissible that the "+ Temp" and "- Temp" signals are interconnected with one another!

4.9.4 Dimension drawings

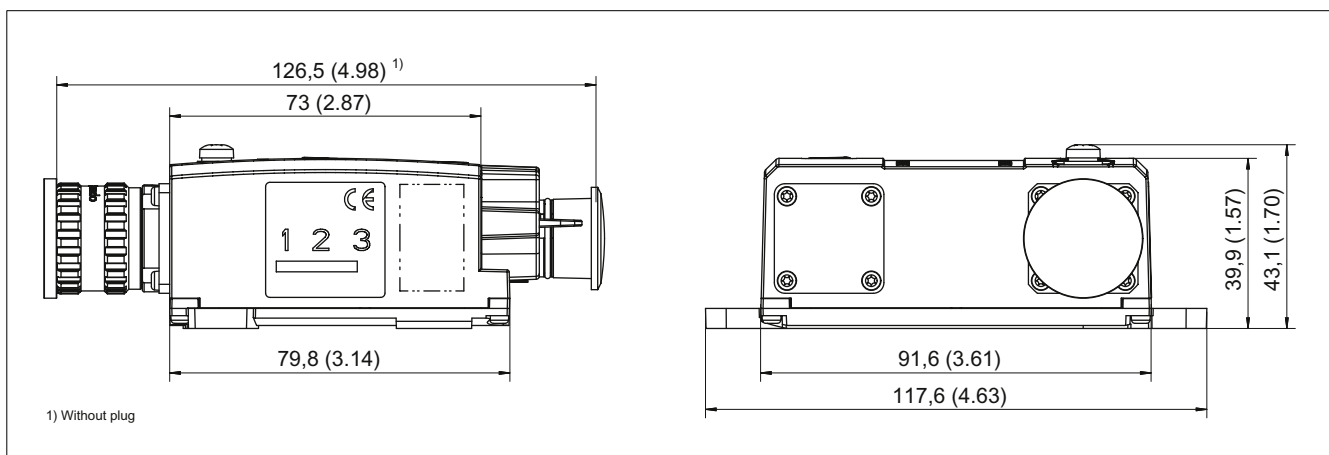

Figure 4-52 Dimension drawing of Sensor Module External SME125, all data in mm and (inches) order number 6SL3055-0AA00-5KA3

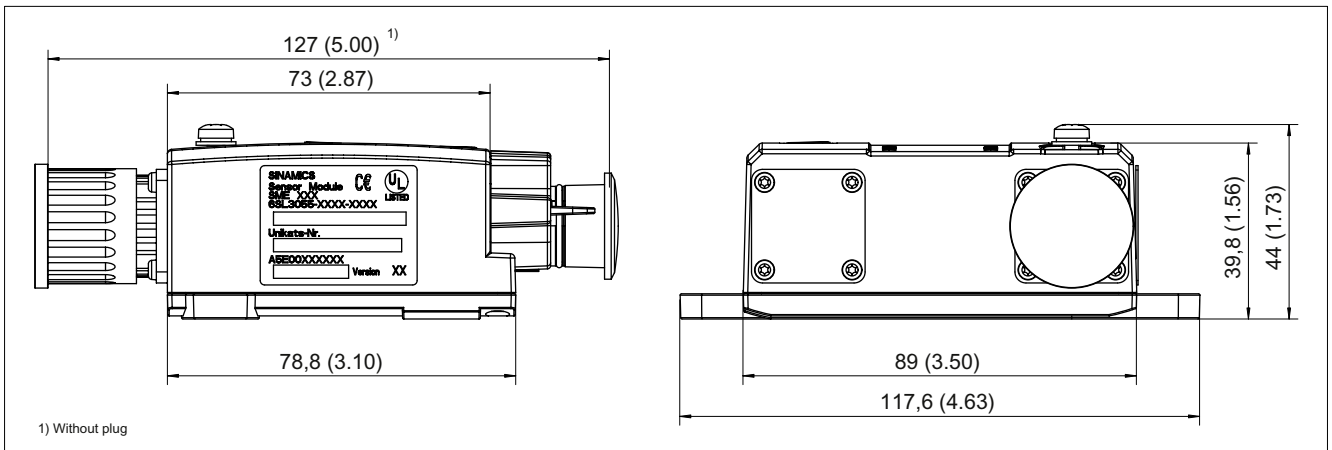

Figure 4-53 Dimension drawing of Sensor Module External SME125, all data in mm and (inches)
order number 6SL3055-0AAA00-5KA0

4.9.5 Installation

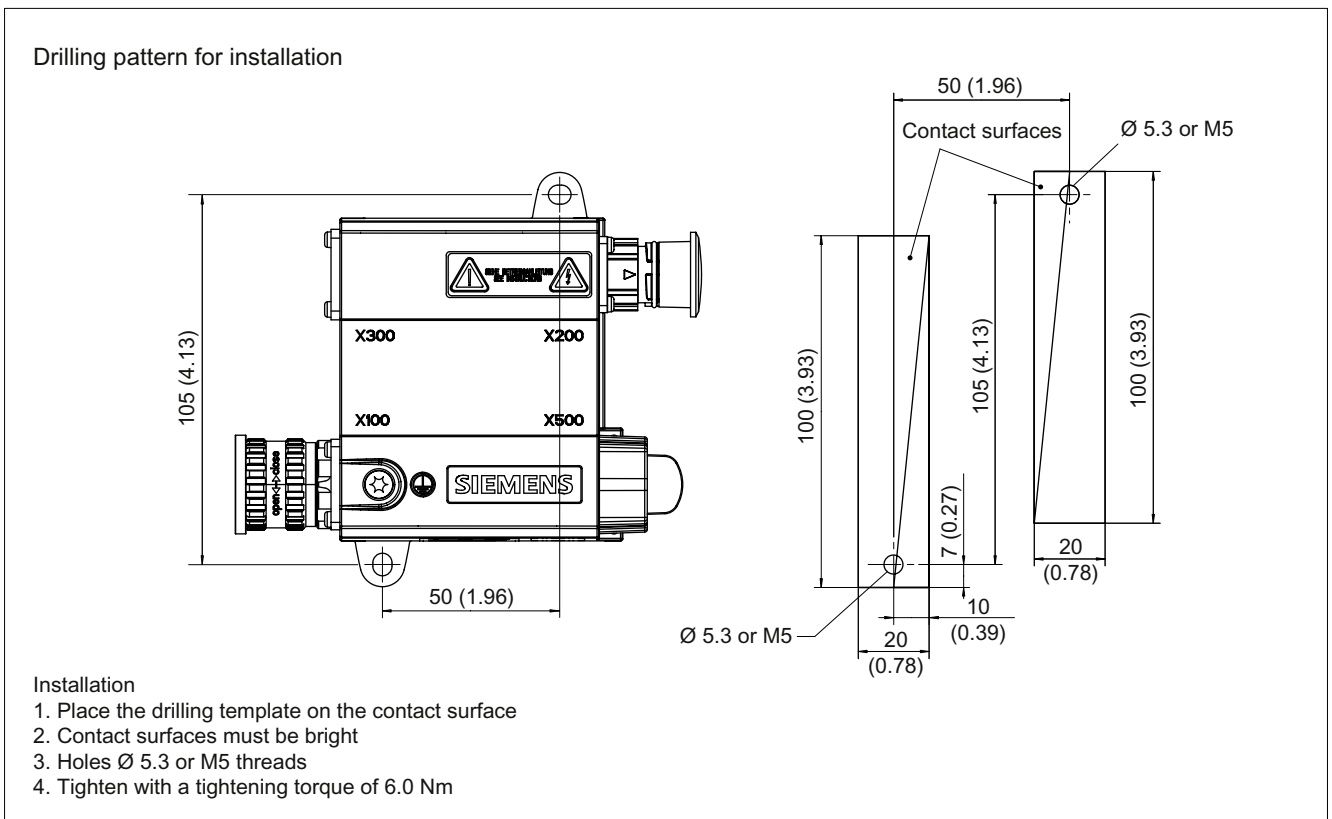

Figure 4-54 SME125 installation

4.9.6 Technical data

Table 4- 36 Technical data

6SL3055-0AA00-5KAx	Unit	Value
Electronics power supply		
Voltage	V_{DC}	24 DC (20.4 – 28.8)
Current (without encoder system)	A_{DC}	≤ 0.20
Current (with encoder system)	A_{DC}	≤ 0.30
Power loss	W	≤ 4.5
Encoder system power supply		
Voltage	$V_{encoder}$	5 VDC
Current	$A_{encoder}$	0.35
Encoder frequency that can be evaluated ($f_{encoder}$)	kHz	≤ 500
SSI/EnDat 2.1 baud rate	kHz	100
PE/ground connection		On housing with M4/1.8 Nm screw
Weight	kg	0.4 (order number 6SL3055-0AA00-5KA0) 0.7 (order number 6SL3055-0AA00-5KA3)
Degree of protection		IP67

NOTICE

In order to guarantee the degree of protection, all of the plug connectors must be correctly screwed into place and appropriately locked.

The maximum cable length for the encoder system interface depends on the current consumption of the encoder system and the cross-section of the wire in the cable. However, the maximum length is 10 m. The figure below applies to encoder systems that operate in the supply voltage range between 4.75 V and 5.25 V. The sample parameters shown are 0.28 mm² cross-section (0.14 mm² supply plus 0.14 mm² Remote Sense wires) and 0.64 mm² (0.5 mm² supply plus 0.14 mm² Remote Sense wires).

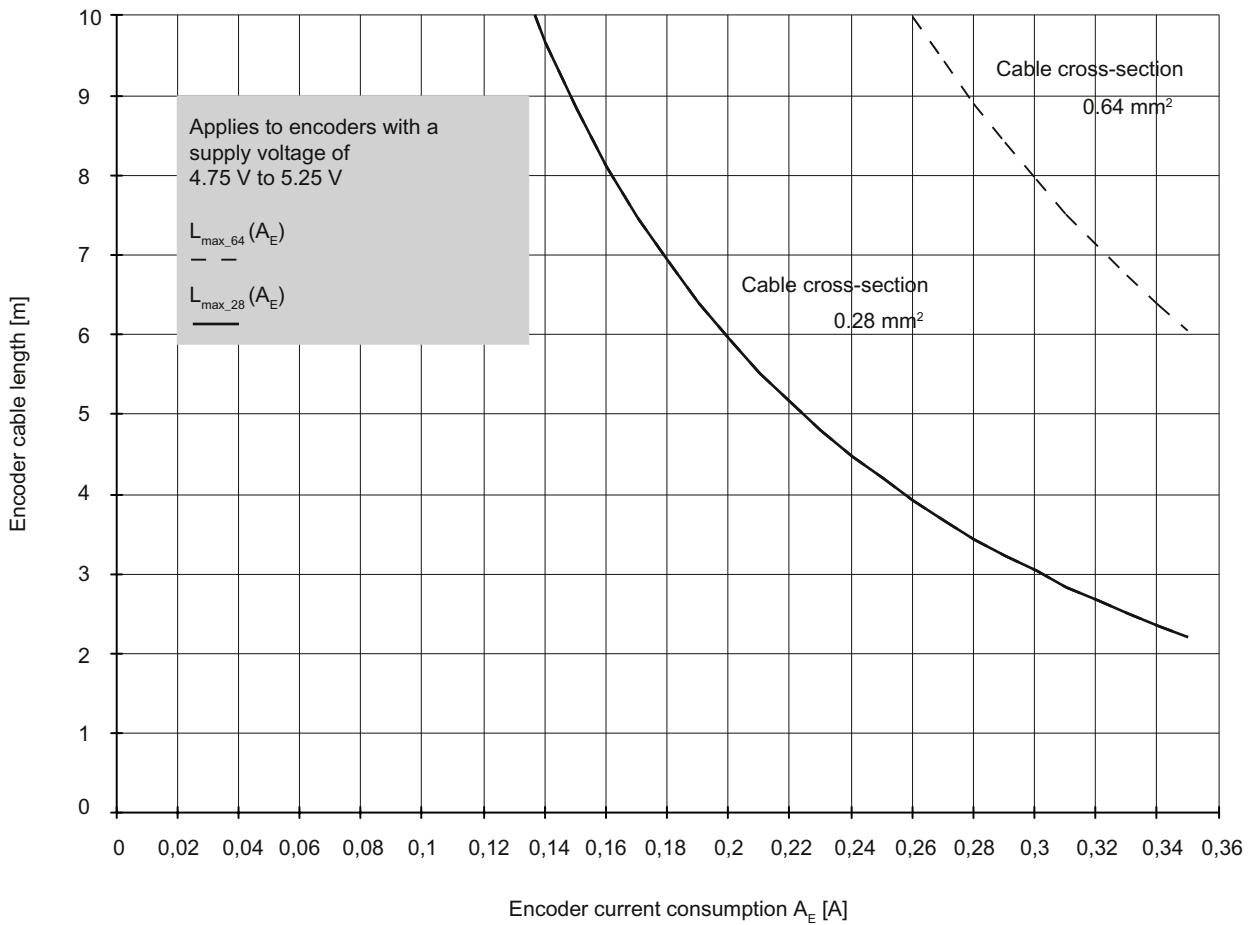

Figure 4-55 Max. cable length as a function of the current drawn by the encoder system

Besides the encoder systems for the supply voltage range of 4.75 V to 5.25 V in the figure above, encoder systems are also available for the extended range down to 3.6 V. These are generally operable using encoder system cables up to 10 m in length, provided that the total cross-section of the supply plus Remote Sense wires does not fall below 0.14 mm².

4.10 DRIVE-CLiQ encoder

4.10.1 Description

The DRIVE-CLiQ encoder is available as an absolute encoder with integrated DRIVE-CLiQ interface. The encoder senses absolute position values extending over 4096 revolutions.

The most important advantages are:

- Automatic commissioning via DRIVE-CLiQ
- High operating temperatures of 100 °C are possible
- Integrated diagnostics concept

Table 4- 37 Encoder for mounting with DRIVE-CLiQ

Designation	Order number	Description
DRIVE-CLiQ synchronous flange VW 6 mm	6FX2001-5FD13-0AAx	Absolute encoder with DRIVE-CLiQ, single-turn
DRIVE-CLiQ clamping flange VW 10 mm	6FX2001-5QD13-0AAx	Absolute encoder with DRIVE-CLiQ, single-turn
DRIVE-CLiQ hollow shaft 10 mm	6FX2001-5VD13-0AAx	Absolute encoder with DRIVE-CLiQ, single-turn
DRIVE-CLiQ hollow shaft 12 mm	6FX2001-5WD13-0AAx	Absolute encoder with DRIVE-CLiQ, single-turn
DRIVE-CLiQ synchronous flange VW 6 mm	6FX2001-5FD25-0AAx	Absolute encoder with DRIVE-CLiQ, multiturn
DRIVE-CLiQ clamping flange VW 10 mm	6FX2001-5QD25-0AAx	Absolute encoder with DRIVE-CLiQ, multiturn
DRIVE-CLiQ hollow shaft 10 mm	6FX2001-5VD25-0AAx	Absolute encoder with DRIVE-CLiQ, multiturn
DRIVE-CLiQ hollow shaft 12 mm	6FX2001-5WD25-0AAx	Absolute encoder with DRIVE-CLiQ, multiturn

4.10.2 Safety information

 CAUTION
<p>The encoder has direct contact to components that can be destroyed by electrostatic discharge (ESDS). Neither hands nor tools that could be electrostatically charged should come into contact with the connections.</p>

4.10.3 Interface description

4.10.3.1 Overview



Figure 4-56 DRIVE-CLiQ encoder

4.10.3.2 DRIVE-CLiQ interface

Table 4- 38 DRIVE-CLiQ interface

	Pin	Signal name	Technical specifications
	1	TXP	Transmit data +
	2	TXN	Transmit data -
	3	RXP	Receive data +
	4	Reserved, do not use	
	5	Reserved, do not use	
	6	RXN	Receive data -
	7	Reserved, do not use	
	8	Reserved, do not use	
	A	Reserved, do not use	
	B	M (0 V)	Electronics ground

Blanking plate for DRIVE-CLiQ interface included in the scope of delivery;
blanking plug (50 pieces) order number: 6SL3066-4CA00-0AA0

4.10.4 Dimension drawings

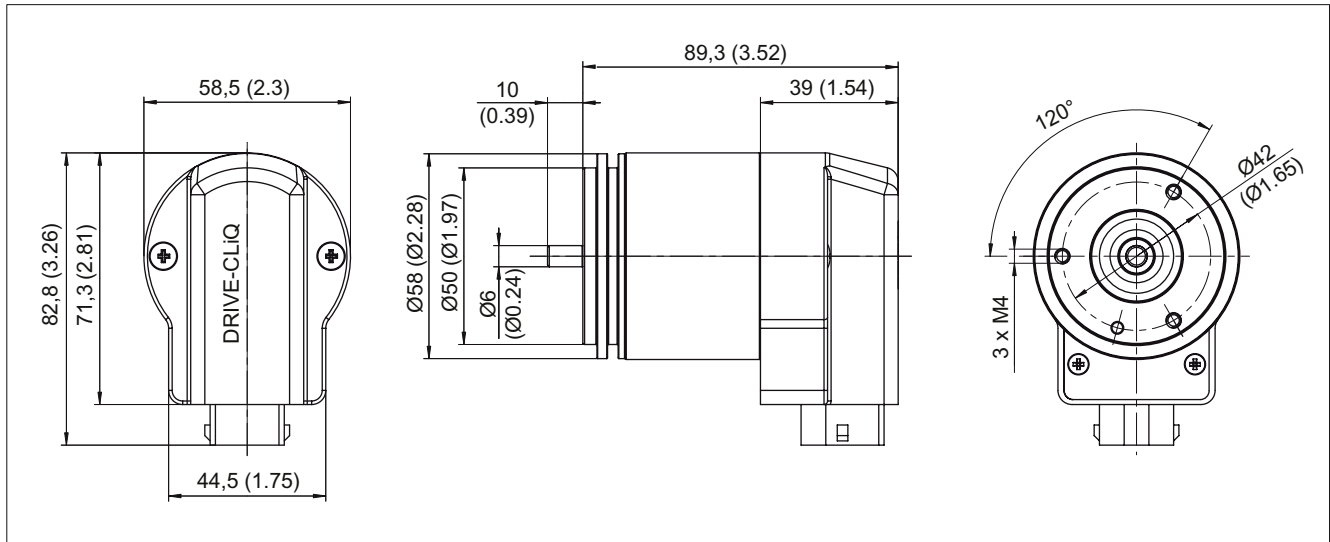

Figure 4-57 Dimension drawing of synchronous flange, all data in mm and (inches)

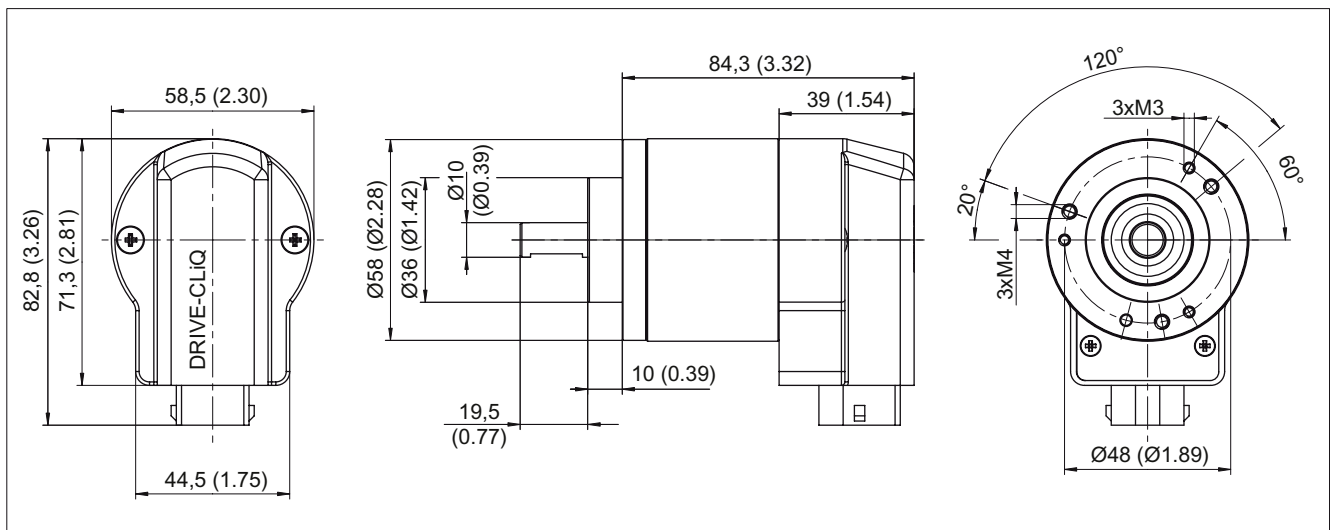

Figure 4-58 Dimension drawing of clamping flange, all data in mm and (inches)

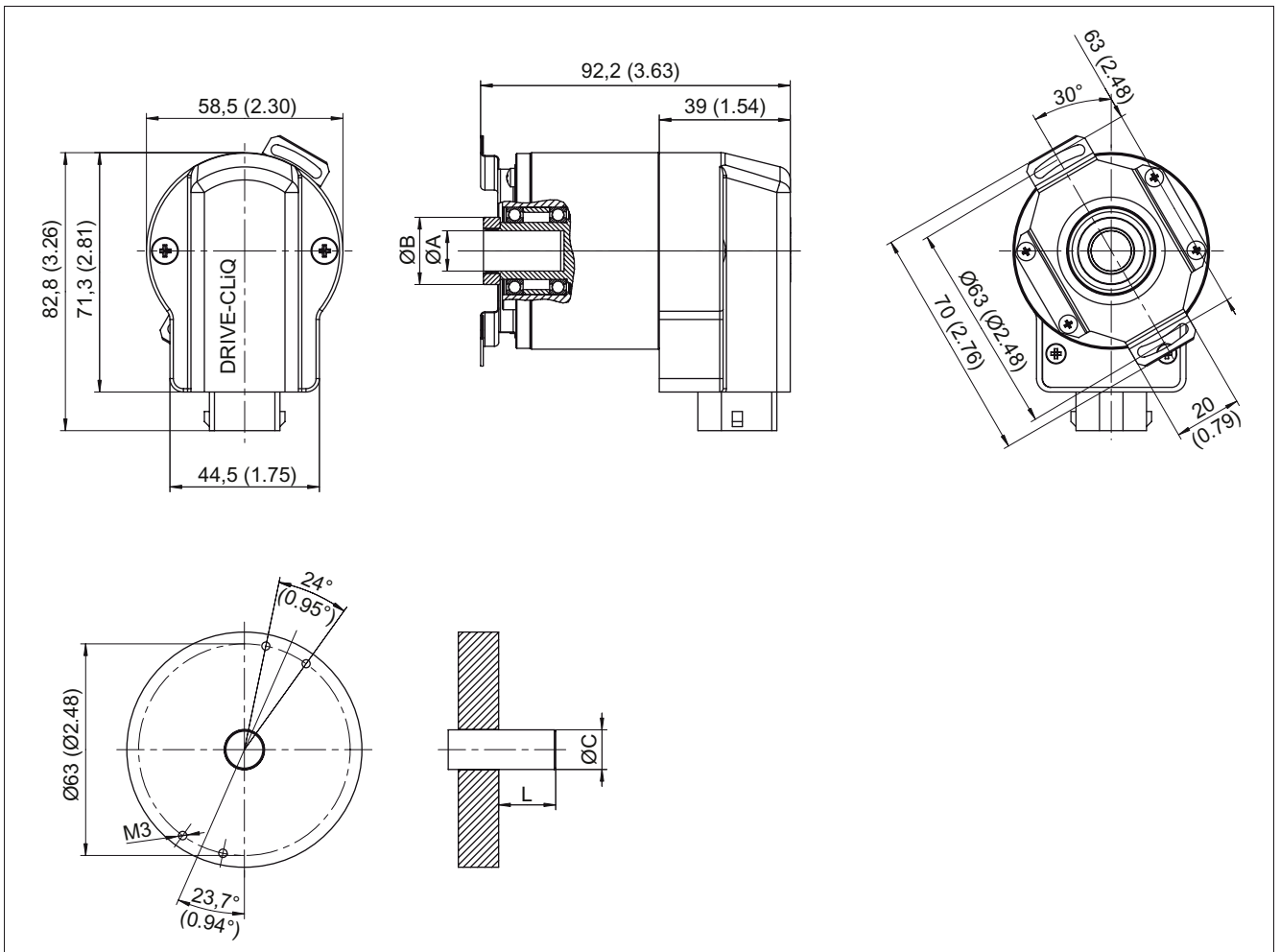

Figure 4-59 Dimension drawing of hollow shaft, all data in mm and (inches)

Table 4-39 Dimensions

	Dimensions		Unit
	mm	inch	
Hollow shaft ØA	10 ^{+0.012} (0.39)	12 ^{+0.012} (0.47)	mm (inch)
Connection shafts ØC	10 (0.39)	12 (0.47)	mm (inch)
Clamping ring ØB	18 (0.70)	20 (0.78)	mm (inch)
L min.	15 (0.59)	18 (0.70)	mm (inch)
L max.	20 (0.78)	20 (0.78)	mm (inch)
Shaft code	2 (0.07)	7 (0.27)	mm (inch)

L = Engaged depth of the connection shaft into the encoder

4.10.5 Installation

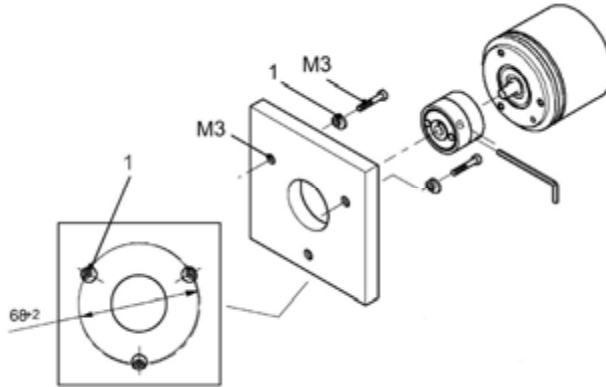

Figure 4-60 Installation: Synchronous flange, 1: Clamp straps

Clamp straps / couplings

Clamp straps and couplings are required as mounting accessories. The clamp straps are used to fix the encoders with a synchronous flange.

Table 4- 40 Selection and ordering data

Designation	Order No.
Clamp strap (No.1 in the drawing) for encoder with synchronous flange (3 units are required)	6FX2001-7KP01
Spring disk coupling Shaft diameter:	
• 6 mm / 6 mm	6FX2001-7KF10
• 6 mm / 5 mm	6FX2001-7KF06
Plug-in coupling Shaft diameter:	
• 6 mm / 6 mm	6FX2001-7KS06
• 10 mm / 10 mm	6FX2001-7KS10

Table 4- 41 Installation instructions

Product name	Spring disk coupling	Plug-in coupling
Transmission torque, max.	0.8 Nm	0.7 Nm
Shaft diameter	6 mm both ends or $d_1 = 6 \text{ mm}$, $d_2 = 5 \text{ mm}$	6 mm both ends or 10 mm both ends
Center offset of shafts, max.	0.4 mm	0.5 mm
Axial offset	$\pm 0.4 \text{ mm}$	$\pm 0.5 \text{ mm}$
Angular displacement of shafts, max.	3°	1°
Torsional rigidity	150 Nm / rad	31 Nm / rad
Lateral spring stiffness	6 N / mm	10 N / mm
Moment of inertia	19 gcm ²	20 gcm ²
Max. speed	12000 rpm	12000 rpm
Operating temperature	-20 ... +150 °C	-20 ... +80 °C
Weight, approx.	16 g	20 g

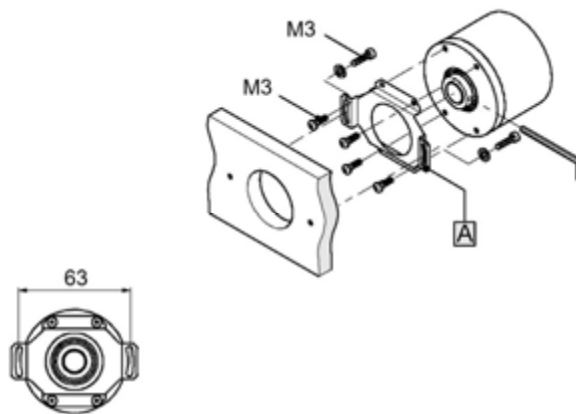

Figure 4-61 Installation: Hollow shaft, A: Spring plate (included in scope of supply)

4.10.6 Technical data

Table 4- 42 Technical data of DRIVE-CLiQ encoders

Design	Unit	Absolute encoder with DRIVE-CLiQ
Operating voltage at encoder	V	24 V -15% / +20%
Current drain Single-turn Multiturn	mA mA	approx. 245 approx. 325
Interface		DRIVE-CLiQ
Electrical speed, permissible	rpm	14.000
Mechanical speed, max.	rpm	10.000
Max. cable length	m	100
Connection		DRIVE-CLiQ connector, radial
Resolution Single-turn Multiturn	Bit Bit	22 34 (22 bit single-turn + 12 bit multiturn)
Accuracy	Angular seconds	+/- 35
Frictional torque	Nm	<= 0.01 (at 20 °C)
Starting torque	Nm	<= 0.01 (at 20 °C)
Shaft load capability d 10 x 19.5 70° n > 6000 rpm n <= 6000 rpm		axial 40 N / radial 40 N at the shaft end axial 40 N / radial 60 N at the shaft end
Angular acceleration, max.	rad/s ²	10 ⁵
Moment of inertia of the rotor, solid shaft Moment of inertia of the rotor, hollow shaft	kgm ²	1.90 * 10 ⁻⁶ kgm ² 2.80 * 10 ⁻⁶ kgm ²
Vibratory load acc. to DIN IEC 68-2-6	m/s ²	<= 100 (10 - 500 Hz)
Shock (6 ms) acc. to DIN IEC 68-2-27	m/s ²	<= 1000 (6 ms)
Operating temperature min. Operating temperature, max.	°C °C	- 20 100
Degree of protection (acc. to DIN EN 60529)		IP67 at the frame IP64 at the shaft input
Weight Single-turn Multiturn	kg kg	0.40 0.44
CE mark		Yes

Information on electromagnetic compatibility (EMC)

5.1 Cabinet design and EMC Booksize

Information on control cabinet installation and electromagnetic compatibility (EMC), as well as on overcurrent and overvoltage protection, can be found in:

/GH2/ SINAMICS S120

Manual for Booksize Power units

Order No.: 6SL3097-4AC00-0AP1, Edition: 11/2009

Appendix A

A.1 Connectable conductor cross-sections for spring-loaded terminals

Table A- 1 Spring-loaded terminals

Spring-loaded terminal type			
1	Connectable conductor cross-sections	Rigid Flexible Flexible with end sleeve without plastic sleeve AWG/kcmil	0.14 mm ² to 0.5 mm ² 0.14 mm ² to 0.5 mm ² 0.25 mm ² to 0.5 mm ² 26 to 20
	Stripped length	8 mm	
	Tool	Screwdriver 0.4 x 2.0 mm	
2	Connectable conductor cross-sections	Flexible	0.08 mm ² to 2.5 mm ²
	Stripped length	8 to 9 mm	
	Tool	Screwdriver 0.4 x 2.0 mm	
3	Connectable conductor cross-sections	Rigid Flexible Flexible with end sleeve without plastic sleeve Flexible with end sleeve with plastic sleeve AWG/kcmil	0.2 mm ² to 1 mm ² 0.2 mm ² to 1.5 mm ² 0.25 mm ² to 1.5 mm ² 0.25 mm ² to 0.75 mm ² 24 to 16
	Stripped length	8 mm	
	Tool	Screwdriver 0.4 x 2.0 mm	
4	Connectable conductor cross-sections	25 mm ² to 95 mm ² AWG 4 to 4/0	
	Stripped length	35 mm	
5	Connectable conductor cross-sections	Rigid Flexible Flexible with end sleeve without plastic sleeve Flexible with end sleeve with plastic sleeve AWG/kcmil	0.2 mm ² to 10 mm ² 0.2 mm ² to 6 mm ² 0.25 mm ² to 6 mm ² 0.25 mm ² to 4 mm ² 24 to 8
	Stripped length	15 mm	

A.2 Connectable conductor cross-sections for screw terminals

Table A-2 Screw terminals

Screw terminal type			
1	Connectable conductor cross-sections	Rigid, flexible With wire end ferrule, without plastic sleeve With wire end ferrule, with plastic sleeve	0.08 mm ² to 1.5 mm ² 0.25 mm ² to 1.5 mm ² 0.25 mm ² to 0.5 mm ²
	Stripped length	7 mm	
	Tool	Screwdriver 0.4 x 2.0 mm	
	Tightening torque	0.22 to 0.25 Nm	
2	Connectable conductor cross-sections	Rigid, flexible With wire end ferrule, without plastic sleeve With wire end ferrule, with plastic sleeve	0.08 mm ² to 2.5 mm ² 0.5 mm ² to 2.5 mm ² 0.5 mm ² to 1.5 mm ²
	Stripped length	7 mm	
	Tool	Screwdriver 0.6 x 3.5 mm	
	Tightening torque	0.5 to 0.6 Nm	
3	Connectable conductor cross-sections	Flexible With wire end ferrule, without plastic sleeve With wire end ferrule, with plastic sleeve	0.2 mm ² to 2.5 mm ² 0.25 mm ² to 1 mm ² 0.25 mm ² to 1 mm ²
	Stripped length	9 mm	
	Tool	Screwdriver 0.6 x 3.5 mm	
	Tightening torque	0.5 to 0.6 Nm	
4	Connectable conductor cross-sections	Flexible With wire end ferrule, without plastic sleeve With wire end ferrule, with plastic sleeve	0.2 mm ² to 4 mm ² 0.25 mm ² to 4 mm ² 0.25 mm ² to 4 mm ²
	Stripped length	7 mm	
	Tool	Screwdriver 0.6 x 3.5 mm	
	Tightening torque	0.5 to 0.6 Nm	
5	Connectable conductor cross-sections	Flexible With wire end ferrule, without plastic sleeve With wire end ferrule, with plastic sleeve	0.5 mm ² to 6 mm ² 0.5 mm ² to 6 mm ² 0.5 mm ² to 6 mm ²
	Stripped length	12 mm	
	Tool	Screwdriver 1.0 x 4.0 mm	
	Tightening torque	1.2 to 1.5 Nm	
6	Connectable conductor cross-sections	Flexible With wire end ferrule, without plastic sleeve With wire end ferrule, with plastic sleeve	0.5 mm ² to 10 mm ² 0.5 mm ² to 10 mm ² 0.5 mm ² to 10 mm ²
	Stripped length	11 mm	
	Tool	Screwdriver 1.0 x 4.0 mm	
	Tightening torque	1.5 to 1.8 Nm	
7	Connectable conductor cross-sections	0.5 mm ² to 16 mm ²	
	Stripped length	14 mm	
	Tool	Screwdriver 1.0 x 4.0 mm	
	Tightening torque	1.5 to 1.7 Nm	

Appendix B

B.1 List of abbreviations

Note:

The following list of abbreviations includes all abbreviations and their meanings used in the entire SINAMICS user documentation.

Abbreviation	Source of abbreviation	Meaning
A		
A...	Alarm	Alarm
AC	Alternating Current	Alternating current
ADC	Analog Digital Converter	Analog digital converter
AI	Analog Input	Analog input
AIM	Active Interface Module	Active Interface Module
ALM	Active Line Module	Active Line Module
AO	Analog Output	Analog output
AOP	Advanced Operator Panel	Advanced Operator Panel
APC	Advanced Positioning Control	Advanced Positioning Control
AR	Automatic Restart	Automatic restart
ASC	Armature Short Circuit	Armature short circuit
ASCII	American Standard Code for Information Interchange	American standard code for information interchange
ASM	Induction motor	Induction motor
B		
OC	Operating Condition	Operating condition
BERO	-	Contactless proximity switch
BI	Binector Input	Binector input
BIA	Germany's Institute for Occupational Safety and Health	Germany's Institute for Occupational Safety and Health
BICO	Binector Connector Technology	Binector connector technology
BLM	Basic Line Module	Basic Line Module
BO	Binector Output	Binector output
BOP	Basic Operator Panel	Basic Operator Panel

Abbreviation	Source of abbreviation	Meaning
C		
C	Capacitance	Capacitance
C...	-	Safety message
CAN	Controller Area Network	Serial bus system
CBC	Communication Board CAN	Communication board CAN
CD	Compact Disc	Compact Disc
CDS	Command Data Set	Command data set
CF Card	CompactFlash Card	CompactFlash Card
CI	Connector Input	Connector input
CLC	Clearance Control	Clearance control
CNC	Computer Numerical Control	Computer numerical control
CO	Connector Output	Connector output
CO/BO	Connector Output/Binector Output	Connector/binector output
COB ID	CAN Object Identification	CAN Object identification
COM	Common contact of a changeover relay	Center contact of a changeover contact
COMM	Commissioning	Commissioning
CP	Communication Processor	Communication processor
CPU	Central Processing Unit	Central processing unit
CRC	Cyclic Redundancy Check	Cyclic redundancy check
CSM	Control Supply Module	Control Supply Module
CU	Control Unit	Control Unit
CUA	Control Unit Adapter	Control Unit Adapter
CUD	Control Unit DC MASTER	Control Unit DC MASTER
D		
DAC	Digital Analog Converter	Digital analog converter
DC	Direct Current	DC current
DCB	Drive Control Block	Drive Control Block
DCC	Drive Control Chart	Drive Control Chart
DCC	Data Cross Check	Crosswise data comparison
DCN	Direct Current Negative	DC current negative
DCP	Direct Current Positive	DC current positive
DDS	Drive Data Set	Drive data set
DI	Digital Input	Digital input
DI/DO	Digital Input/Digital Output	Digital input/output bidirectional
DMC	DRIVE-CLiQ Hub Module Cabinet	DRIVE-CLiQ Hub Module Cabinet
DME	DRIVE-CLiQ Hub Module External	DRIVE-CLiQ Hub Module External
DO	Digital Output	Digital output
DO	Drive Object	Drive object
DP	Decentralized Peripherals	Distributed IOs
DPRAM	Dual Ported Random Access Memory	Memory with dual access ports

Abbreviation	Source of abbreviation	Meaning
DRAM	Dynamic Random Access Memory	Dynamic memory
DRIVE-CLiQ	Drive Component Link with IQ	Drive Component Link with IQ
DSC	Dynamic Servo Control	Dynamic Servo Control
E		
EASC	External Armature Short Circuit	External armature short circuit
EDS	Encoder Data Set	Encoder data set
ESD	Electrostatic Sensitive Devices	Electrostatic sensitive devices
ELCB	Earth Leakage Circuit Breaker	Earth leakage circuit breaker
ELP	Earth Leakage Protection	Earth leakage protection
EMC	Electromagnetic Compatibility	Electromagnetic compatibility
EMF	Electromagnetic Force	Electromagnetic force
EMF	Electromagnetic force	Electromagnetic force
EMC	Electromagnetic compatibility	Electromagnetic compatibility
EN	European standard	European standard
EnDat	Encoder Data Interface	Encoder interface
EP	Enable Pulses	Pulse enable
EPOS	Basic positioner	Basic positioner
ES	Engineering System	Engineering System
ESB	Equivalent circuit diagram	Equivalent circuit diagram
ESD	Electrostatic Sensitive Devices	Electrostatic sensitive devices
ESR	Extended Stop and Retract	Extended stop and retract
F		
F...	Fault	Fault
FAQs	Frequently Asked Questions	Frequently asked questions
FBL	Free Blocks	Free function blocks
FCC	Function Control Chart	Function Control Chart
FCC	Flux Current Control	Flux current control
FD	Function Diagram	Function diagram
F-DI	Failsafe Digital Input	Fail-safe digital input
F-DO	Failsafe Digital Output	Fail-safe digital output
FEM	Separately excited synchronous motor	Separately excited synchronous motor
FEPROM	Flash EPROM	Non volatile read and write memory
FG	Function Generator	Function generator
FI	-	Fault current
FOC	Fiber-Optic Cable	Fiber-optic cable
FP	Function diagram	Function diagram
FPGA	Field Programmable Gate Array	Field Programmable Gate Array
FW	Firmware	Firmware
G		
GB	Gigabyte	Gigabyte

Abbreviation	Source of abbreviation	Meaning
GC	Global Control	Global Control Telegram (Broadcast Telegramm)
GND	Ground	Reference potential for all signal and operating voltages, usually defined as 0 V (also referred to as G)
GSD	Generic Station Description	Generic station description: Describes the characteristics of a PROFIBUS slave
GSV	Gate Supply Voltage	Gate Supply Voltage
GUID	Globally Unique Identifier	Globally unique identifier
H		
HF	High Frequency	High frequency
HFD	High-frequency reactor	High-frequency reactor
RFG	Ramp-Function Generator	Ramp-function generator
HMI	Human Machine Interface	Human machine interface
HTL	High-Threshold Logic	Logic with a high fault threshold
HW	Hardware	Hardware
I		
u.d.	under development	Under development: This feature is not currently available
I/O	Input/Output	Input/output
I2C	Inter-Integrated Circuit	Internal serial data bus
IASC	Internal Armature Short Circuit	Internal armature short circuit
IBN	Commissioning	Commissioning
ID	Identifier	Identification
IE	Industrial Ethernet	Industrial Ethernet
IEC	International Electrotechnical Commission	International Electrotechnical Commission
IF	Interface	Interface
IGBT	Insulated Gate Bipolar Transistor	Insulated gate bipolar transistor
IGCT	Integrated Gate-Controlled Thyristor	Semiconductor power switch with integrated control electrode
IL	Pulse cancelation	Pulse cancelation
IP	Internet Protocol	Internet Protocol
IPO	Interpolator	Interpolator
IT	Isolé Terré	Non-grounded three-phase power supply
IVP	Internal Voltage Protection	Internal voltage protection
J		
JOG	Jogging	Jogging
K		
CDC	Crosswise data comparison	Crosswise data comparison
KIP	Kinetic buffering	Kinetic buffering
Kp	-	Proportional gain
KTY	-	Special temperature sensor

Abbreviation	Source of abbreviation	Meaning
L		
L	-	Formula symbol for inductance
LED	Light Emitting Diode	Light Emitting Diode
LIN	Linear motor	Linear motor
PC	Position Controller	Position Controller
LSB	Least Significant Bit	Least significant bit
LSC	Line-Side Converter	Line-side converter
LSS	Line Side Switch	Line side switch
LU	Length Unit	Length unit
FOC	Fiber-Optic Cable	Fiber-optic cable
M		
M	-	Formula symbol for torque
M	Ground	Reference potential for all signal and operating voltages, usually defined as 0 V (also referred to as GND)
MB	Megabyte	Megabyte
MCC	Motion Control Chart	Motion Control Chart
MDS	Motor Data Set	Motor data set
MLFB	Machine-Readable Product Code	Machine-Readable Product Code
MMC	Man-Machine Communication	Man-machine communication
MMC	Micro Memory Card	Micro memory card
MSB	Most Significant Bit	Most significant bit
MSC	Motor-Side Converter	Motor-side converter
MSCY_C1	Master Slave Cycle Class 1	Cyclic communication between master (Class 1) and slave
MSR	Motor-side converter	Motor-side converter
MT	Probe	Probe
N		
N. C.	Not Connected	Not connected
N...	No Report	No message or internal message
NAMUR	Standardization association for measurement and control in the chemical industry	Standardization association for measurement and control in the chemical industry
NC	Normally Closed (contact)	NC contact
NC	Numerical Control	Numerical control
NEMA	National Electrical Manufacturers Association	Standardization body in the US
NM	Zero mark	Zero mark
NO	Normally Open (contact)	NO contact
NSR	Line-side converter	Line-side converter
NVRAM	Non-Volatile Random Access Memory	Non-volatile read/write memory

Abbreviation	Source of abbreviation	Meaning
O		
OA	Open Architecture	Open Architecture
OC	Operating Condition	Operating condition
OEM	Original Equipment Manufacturer	Original Equipment Manufacturer
OLP	Optical Link Plug	Fiber-optic bus connector
OMI	Option Module Interface	Option module interface
P		
p...	-	Adjustable parameters
PB	PROFIBUS	PROFIBUS
PcCtrl	PC Control	Control for master
PD	PROFIdrive	PROFIdrive
PDS	Power unit Data Set	Power unit data set
PE	Protective Earth	Protective earth
PELV	Protective Extra Low Voltage	Protective extra low voltage
PEM	Permanent-magnet synchronous motor	Permanent-magnet synchronous motor
PG	Programming device	Programming device
PI	Proportional Integral	Proportional integral
PID	Proportional Integral Differential	Proportional integral differential
PLC	Programmable Logic Controller	Programmable logic controller
PLL	Phase-Locked Loop	Phase-locked loop
PN	PROFINET	PROFINET
PNO	PROFIBUS user organization	PROFIBUS user organization
PPI	Point-to-Point Interface	Point-to-point interface
PRBS	Pseudo Random Binary Signal	White noise
PROFIBUS	Process Field Bus	Serial data bus
PS	Power Supply	Power supply
PSA	Power Stack Adapter	Power Stack Adapter
PTC	Positive Temperature Coefficient	Positive temperature coefficient
PTP	Point-To-Point	Point-to-Point
PWM	Pulse Width Modulation	Pulse width modulation
PZD	Process data	Process data
R		
r...	-	Display parameters (read-only)
RAM	Random Access Memory	Read/write memory
RCCB	Residual Current Circuit Breaker	Residual current operated circuit breaker
RCD	Residual Current Device	Residual current operated circuit breaker
RCM	Residual Current Monitor	Residual current monitor
RFG	Ramp-Function Generator	Ramp-function generator
RJ45	Registered Jack 45	Term for an 8-pin socket system for data transmission with shielded or non-shielded multi-wire copper cables

Abbreviation	Source of abbreviation	Meaning
RKA	Cooling unit	Cooling unit
RO	Read Only	Read only
RPDO	Receive Process Data Object	Receive process data object
RS232	Recommended Standard 232	Interface standard for cable-connected serial data transmission between a sender and receiver (also known under EIA232)
RS485	Recommended Standard 485	Interface standard for a cable-connected differential, parallel, and/or serial bus system (data transmission between a number of senders and receivers, also known under EIA485)
RTC	Real Time Clock	Real time clock
RZA	Space vector approximation	Space vector approximation
S		
S1	-	Uninterrupted duty
S3	-	Intermittent duty
SBC	Safe Brake Control	Safe brake control
SBH	Safe operating stop	Safe operating stop
SBR	-	Safe acceleration monitoring
SCA	Safe Cam	Safe cam
SD Card	SecureDigital Card	Secure digital memory card
SE	Safe software limit switch	Safe software limit switch
SG	Safely reduced speed	Safely reduced speed
SGA	Safety-related output	Safety-related output
SGE	Safety-related input	Safety-related input
SH	Safe standstill	Safe standstill
SI	Safety Integrated	Safety Integrated
SIL	Safety Integrity Level	Safety Integrity Level
SLM	Smart Line Module	Smart Line Module
SLP	Safely-Limited Position	Safely-limited position
SLS	Safely Limited Speed	Safely limited speed
SLVC	Sensorless Vector Control	Vector control without encoder
SM	Sensor Module	Sensor Module
SMC	Sensor Module Cabinet	Sensor Module Cabinet
SME	Sensor Module External	Sensor Module External
SN	Safe software cam	Safe software cam
SOS	Safe Operating Stop	Safe operating stop
SP	Service Pack	Service pack
SPC	Setpoint Channel	Setpoint channel
SPI	Serial Peripheral Interface	Serial interface for connecting peripherals
PLC	Programmable Logic Controller	Programmable logic control

Abbreviation	Source of abbreviation	Meaning
SS1	Safe Stop 1	Safe stop 1 (monitored for time and ramping up)
SS2	Safe Stop 2	Safe stop 2
SSI	Synchronous Serial Interface	Synchronous serial interface
SSM	Safe Speed Monitor	Safe feedback for speed monitoring (n < nx)
SSP	SINAMICS Support Package	SINAMICS support package
STO	Safe Torque Off	Safe torque off
STW	Control word	Control word
T		
TB	Terminal Board	Terminal Board
TIA	Totally Integrated Automation	Totally Integrated Automation
TM	Terminal Module	Terminal module
TN	Terre Neutre	Grounded three-phase supply network
Tn	-	Integral time
TPDO	Transmit Process Data Object	Transmit process data object
TT	Terre Terre	Grounded three-phase supply network
TTL	Transistor-Transistor Logic	Transistor-transistor logic
Tv	-	Rate time
U		
UL	Underwriters Laboratories Inc.	Underwriters Laboratories Inc.
UPS	Uninterruptible Power Supply	Uninterruptible power supply
UPS	Uninterruptible Power Supply	Uninterruptible power supply
UTC	Universal Time Coordinated	Universal time coordinated
V		
VC	Vector Control	Vector control
Vdc	-	DC link voltage
VdcN	-	Partial DC link voltage negative
VdcP	-	Partial DC link voltage positive
VDE	Verband Deutscher Elektrotechniker	Association of German electrical engineers
VDI	Verein Deutscher Ingenieure	Association of German Engineers
VPM	Voltage Protection Module	Voltage Protection Module
Vpp	Volt peak-to-peak	Volt peak-to-peak
VSM	Voltage Sensing Module	Voltage Sensing Module
W		
AR	Automatic restart	Automatic restart
MT	Machine Tool	Machine tool
X		
XML	Extensible Markup Language	Standard language for Web publishing and document management

Abbreviation	Source of abbreviation	Meaning
Z		
DC link	DC link	DC link
ZM	Zero Mark	Zero mark
ZSW	Status word	Status word

SINAMICS documentation overview

General documentation/catalogs

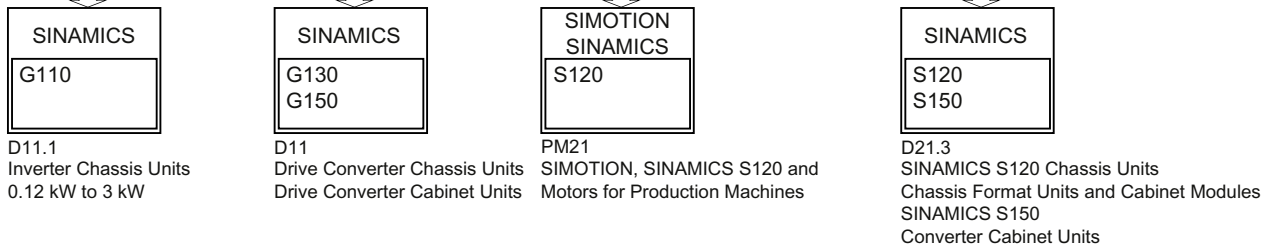

Manufacturer/service documentation

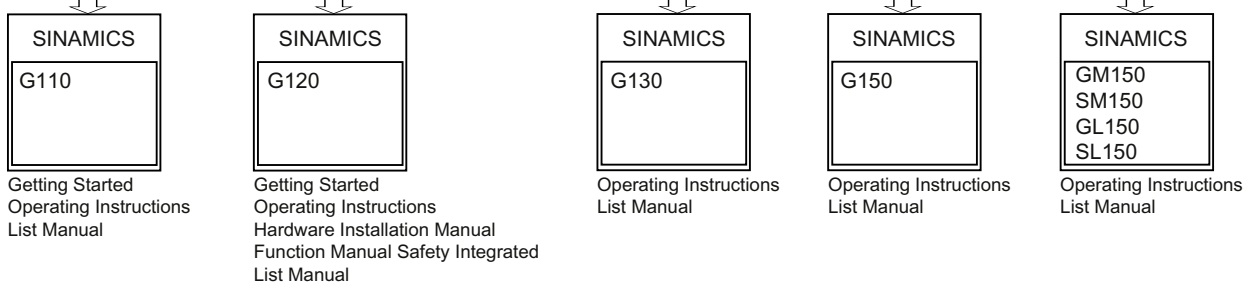

Manufacturer/service documentation

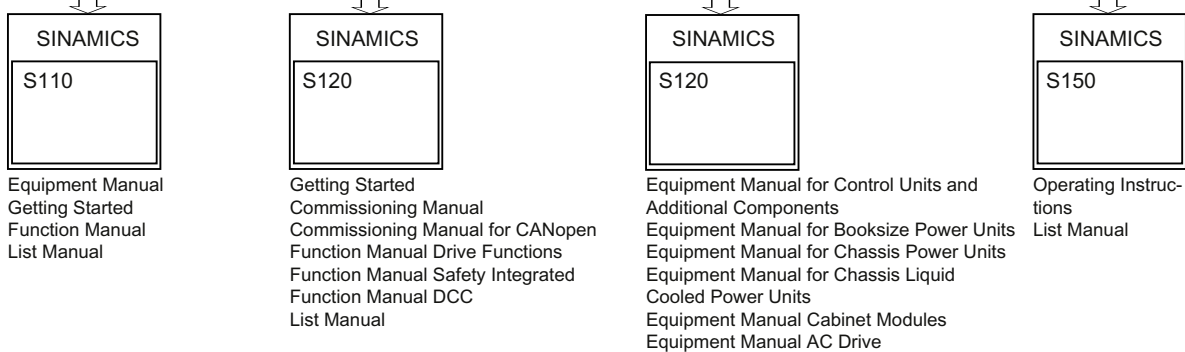

Manufacturer/service documentation

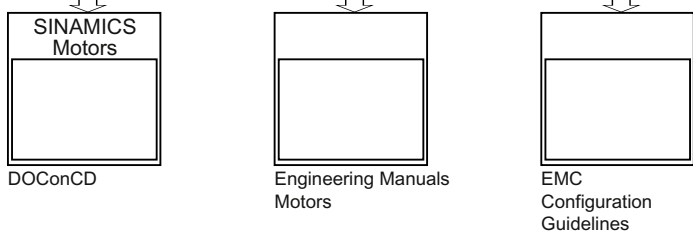



Fax template

Suggested improvements

If you come across any misprints in this document, please let us know using this form. We would also be grateful for any suggestions and recommendations for improvement.

To: SIEMENS AG I DT MC MS1 P.O. Box 3180 D-91050 Erlangen, Federal Republic of Germany Fax: +49 (0) 9131 / 98 - 2176 (documentation) mailto:docu.motioncontrol@siemens.com http://www.siemens.com/automation/service&support	From
	Name:
	Address of your Company/Dept.
	Street:
	Postal code: Location:
	Phone: /
Fax: /	

Suggestions and/or corrections

Index

A

Address

Setting the PROFIBUS address, 71

Ambient temperature, 28

B

Basic Operator Panel BOP20, 87

C

Communication Board CBC10, 93

Communication Board CBE20, 99

Components

Basic Operator Panel BOP20, 87

Communication Board CBC10, 93

Communication Board CBE20, 99

Control Unit CU320, 37

Control Unit CU320-2 DP, 60

DRIVE-CLiQ encoder, 304

DRIVE-CLiQ Hub Module DMC20, 195

DRIVE-CLiQ Hub Module External DME20, 201

Terminal Board TB30, 105

Terminal Module TM120, 183

Terminal Module TM15, 113

Terminal Module TM31, 128

Terminal Module TM41, 148

Terminal Module TM54F, 163

Voltage Sensing Module VSM10, 209

Connector coding

Terminal Module TM15, 124

Terminal Module TM31, 146

Control Unit CU320, 37

LEDs after booting, 51

LEDs during booting, 50

Control Unit CU320-2 DP, 60

LEDs after booting, 76

LEDs during booting, 75

D

Diagnostics

using LEDs on Communication Board CBC10, 97

using LEDs on Communication Board CBE20, 102

using LEDs on Control Unit 320, 51

using LEDs on Control Unit CU320-2 DP, 76

using LEDs on Sensor Module Cabinet SMC10, 230

using LEDs on Sensor Module Cabinet SMC20, 240

using LEDs on Sensor Module Cabinet SMC30, 252

using LEDs on Terminal Module TM120, 190

using LEDs on Terminal Module TM15, 120

using LEDs on Terminal Module TM31, 141

using LEDs on Terminal Module TM41, 157

using LEDs on Terminal Module TM54F, 177

via LEDs for DRIVE-CLiQ Hub Module

DMC20, 198

via LEDs for Voltage Sensing Module VSM10, 216

Dimension drawings

Control Unit CU320, 53

Control Unit CU320-2 DP, 78

DRIVE-CLiQ encoder, 306

DRIVE-CLiQ Hub Module DMC20, 199

DRIVE-CLiQ Hub Module External DME20, 205

Sensor Module Cabinet SMC10, 231

Sensor Module Cabinet SMC20, 241

Sensor Module Cabinet SMC30, 253

Sensor Module External SME120, 286

Sensor Module External SME125, 300

Sensor Module External SME20, 265

Sensor Module External SME25, 272

Terminal Module TM120, 191

Terminal Module TM15, 121

Terminal Module TM31, 142

Terminal Module TM41, 158

Terminal Module TM54F, 179

Voltage Sensing Module VSM10, 217

DRIVE-CLiQ encoder, 304

DRIVE-CLiQ Hub Module DMC20, 195

DRIVE-CLiQ Hub Module External DME20, 201

E

Electronics power supply, 28

F

Field of application, 21

I

Installation

- Basic Operator Panel BOP20, 90, 91
- Communication Board CBC10, 98
- Communication Board Ethernet (CBE20), 104
- Control Unit CU320, 55
- Control Unit CU320-2 DP, 80
- DRIVE-CLiQ encoder, 308
- DRIVE-CLiQ Hub Module DMC20, 199
- Sensor Module External SME120, 287
- Sensor Module External SME125, 301
- Sensor Module External SME20/SME25, 266, 273
- Sensor Modules Cabinet-Mounted, 233, 242, 254
- Terminal Board TB30, 111
- Terminal Module TM120, 191
- Terminal Modules, 122, 144, 160, 180

Interface descriptions

- Basic Operator Panel BOP20, 87
- Communication Board CBC10, 94
- Communication Board CBE20, 100
- Control Unit CU320, 39
- Control Unit CU320-2 DP, 62
- DRIVE-CLiQ Hub Module DMC20, 196
- DRIVE-CLiQ Hub Module External DME20, 202
- Sensor Module Cabinet SMC10, 226
- Sensor Module Cabinet SMC20, 237
- Sensor Module Cabinet SMC30, 245
- Sensor Module External SME120, 278
- Sensor Module External SME125, 292
- Sensor Module External SME20, 262
- Sensor Module External SME25, 269
- Terminal Board TB30, 106
- Terminal Module TM120, 184
- Terminal Module TM31, 129
- Terminal Module TM41, 149
- Terminal Module TM54F, 165
- Voltage Sensing Module VSM10, 211

Interface Descriptions

- Terminal Module TM15, 114

Introduction, 23

L

LEDs

- for Sensor Module Cabinet SMC10, 230
- for Sensor Module Cabinet SMC20, 240
- for Sensor Module Cabinet SMC30, 252
- for Terminal Module TM120, 190
- for Terminal Module TM15, 120
- for Terminal Module TM31, 141
- for Terminal Module TM41, 157
- for Terminal Module TM54F, 177
- for the DRIVE-CLiQ Hub Module DMC20, 198
- for the Voltage Sensing Module VSM10, 216

- with Communication Board CBC10, 97
- with Communication Board CBE20, 102
- with Control Unit CU320, 51
- with Control Unit CU320-2 DP, 76

P

- Platform Concept, 22
- PROFIBUS
 - Setting the address, 71
- PROFINET cable, 101
- Protective conductor connection and shield support
 - Terminal Module TM120, 193
 - Terminal Module TM15, 123
 - Terminal Module TM31, 145
 - Terminal Module TM41, 161
 - Terminal Module TM54F, 181
 - Voltage Sensing Module VSM10, 218

R

- Residual risks, 12

S

Safety information

- Communication Board CBC10, 93
- Communication Board CBE20, 99
- Control Unit CU320, 38
- Control Unit CU320-2 DP, 61
- DRIVE-CLiQ Hub Module DMC20, 195
- DRIVE-CLiQ Hub Module External DME20, 201
- Sensor Module Cabinet SMC20, 225, 236, 249, 250, 277
- Sensor Module Cabinet SMC30, 244
- Sensor Module External SME120, 277
- Sensor Module External SME20, 261
- Terminal Board TB30, 105
- Terminal Module TM120, 183
- Terminal Module TM15, 113
- Terminal Module TM31, 128
- Terminal Module TM41, 148
- Terminal Module TM54F, 164

Sensor Modules, 223

Specification of encoder systems and encoders

- Sensor Module Cabinet SMC30, 257

Standards, 30

Storage, 28

Switches for PROFIBUS address, 71

System data, 28

T

Technical data

- Communication Board CBC10, 99
 - Control Unit CU320, 59
 - Control Unit CU320-2 DP, 85
 - DRIVE-CLiQ encoder, 310
 - DRIVE-CLiQ Hub Module DMC20, 200
 - DRIVE-CLiQ Hub Module External DME20, 207
 - Sensor Module Cabinet SMC10, 234
 - Sensor Module Cabinet SMC20, 243
 - Sensor Module Cabinet SMC30, 256
 - Sensor Module External SME120, 288
 - Sensor Module External SME125, 302
 - Sensor Module External SME20, 267
 - Sensor Module External SME25, 274
 - Terminal Board TB30, 113
 - Terminal Module TM120, 194
 - Terminal Module TM15, 125
 - Terminal Module TM31, 147
 - Terminal Module TM41, 162
 - Terminal Module TM54F, 182
 - Voltage Sensing Module VSM10, 219
- Terminal Board TB30, 105
 - Terminal Module TM120, 183
 - Terminal Module TM15, 113
 - Terminal Module TM31, 128
 - Terminal Module TM41, 148
 - Terminal Module TM54F, 163
 - Totally Integrated Automation, 22
 - Transportation, 28

V

- Voltage Sensing Module VSM10, 209

Siemens AG
Industry Sector
Drive Technologies
Motion Control Systems
P.O. Box 3180
91050 ERLANGEN
GERMANY

Subject to change without prior notice
© Siemens AG 2009

www.siemens.com/motioncontrol