



Certification Test Report

**FCC ID: SK9OW1
IC: 864G-OW1**

**FCC Rule Part: 1.1310
ISED Canada Radio Standards Specification: RSS-102**

Report Number: AT72127781-3P0

**Manufacturer: Itron, Inc.
Model: OW1**

**Test Begin Date: June 12, 2017
Test End Date: June 14, 2017**

Report Issue Date: July 14, 2017



FOR THE SCOPE OF ACCREDITATION UNDER Certificate Number: AT-2021

This report must not be used by the client to claim product certification, approval, or endorsement by ANAB, NIST, or any agency of the Federal Government.

Prepared by:

**Ryan McGann
Senior Engineer
TÜV SÜD America Inc.**

Reviewed by:

**Thierry Jean-Charles
EMC Engineer
TÜV SÜD America Inc.**

This test report shall not be reproduced except in full. This report may be reproduced in part with prior written consent of TÜV SÜD America Inc. The results contained in this report are representative of the sample(s) submitted for evaluation.

This report contains 10 pages

TABLE OF CONTENTS

1	GENERAL	3
1.1	PURPOSE.....	3
1.2	PRODUCT DESCRIPTION.....	3
1.3	TEST METHODOLOGY AND CONSIDERATIONS	4
2	TEST FACILITIES.....	5
2.1	LOCATION	5
2.2	LABORATORY ACCREDITATIONS/RECOGNITIONS/CERTIFICATIONS	5
2.3	RADIATED EMISSIONS TEST SITE DESCRIPTION	6
2.3.1	<i>Semi-Anechoic Chamber Test Site</i>	6
3	APPLICABLE STANDARD REFERENCES.....	7
4	LIST OF TEST EQUIPMENT.....	7
5	SUPPORT EQUIPMENT.....	8
6	EQUIPMENT UNDER TEST SETUP BLOCK DIAGRAM.....	8
7	SUMMARY OF TESTS.....	9
7.1	MAXIMUM PERMISSIBLE EXPOSURE – FCC: SECTION 1.1310; ISED CANADA: RSS-102 4.....	9
7.1.1	<i>Measurement Procedure</i>	9
7.1.2	<i>Measurement Results</i>	9
8	ESTIMATION OF MEASUREMENT UNCERTAINTY	10
9	CONCLUSION	10

1 GENERAL

1.1 Purpose

The purpose of this report is to demonstrate compliance with Part 1 Subpart I of the FCC's Code of Federal Regulations and Innovation, Science, and Economic Development Canada's Radio Standards Specification RSS-102 Certification for Maximum Permissible Exposure.

1.2 Product Description

The Itron OW1 is a communications module which includes a 902.4 MHz to 927.6 MHz transmitter. The module operates on DC voltage which is supplied by a host device.

This test report documents the compliance of the maximum permissible exposure for uncontrolled exposure of a fixed device.

900MHz FHSS Radio Technical Information:

Detail	Description
Frequency Range	902.4 – 927.6 MHz
Number of Channels	FSK 10kbps: 513 FSK 50kbps: 64 FSK 150kbps: 64 OFDM: 64 DSSS: 64
Modulation Format	FSK, OFDM, DSSS
Data Rates (kbps)	FSK: 10 (new), 50, 150 OFDM: 200, 600 DSSS: 6.25, 12.5
Operating Voltage	24Vdc
Antenna Type(s) / Gain(s)	Monopole Antenna (original): 2.8 dBi PCTel BOA9028 Omni Antenna (new): 8.15dBi Antenna Products AMR 360-902-5-T0-N Omni Antenna (new): 5.1dBi

900MHz Hybrid Radio Technical Information

Detail	Description
Frequency Range	902.8 – 926.8 MHz
Number of Channels	31
Modulation Format	OFDM
Data Rates (kbps)	1200
Operating Voltage	24Vdc
Antenna Type(s) / Gain(s)	Monopole Antenna (original): 2.8 dBi PCTel BOA9028 Omni Antenna (new): 8.15dBi Antenna Products AMR 360-902-5-T0-N Omni Antenna (new): 5.1 dBi

Manufacturer Information:

Itron, Inc.
313 N Hwy 11
West Union, SC 29696

EUT Serial Number: 9110000875

Test Sample Condition: The test samples were provided in good working order with no visible defects.

1.3 Test Methodology and Considerations

The data presented in this report represents the worst case where applicable. The worst-case data rate was DSSS at 6.25kbps. The EUT is not capable of operating in frequency hopping mode and the Hybrid mode simultaneously.

The EUT was evaluated for maximum permissible exposure in three orthogonal orientations. The data presented in this report represents the worst-case mode of operation.

2 TEST FACILITIES**2.1 Location**

The radiated and conducted emissions test sites are located at the following address:

TÜV SÜD America, Inc.
5015 B.U. Bowman Drive
Buford, GA 30518
Phone: (770) 831-8048
Fax: (770) 831-8598

2.2 Laboratory Accreditations/Recognitions/Certifications

TÜV SÜD America, Inc. is accredited to ISO/IEC 17025 by the ANSI-ASQ National Accreditation Board/ANAB accreditation program, and has been issued certificate number AT-2021 in recognition of this accreditation. Unless otherwise specified, all tests methods described within this report are covered under the ISO/IEC 17025 scope of accreditation.

The Semi-Anechoic Chamber Test Site, Open Area Test Site (OATS) and Conducted Emissions Site have been fully described, submitted to, and accepted by the FCC, ISED Canada and the Japanese Voluntary Control Council for Interference by information technology equipment.

FCC Registration Number: 391271
ISED Canada Lab Code: IC 4175A
VCCI Member Number: 1831

- VCCI OATS Registration Number R-1526
- VCCI Conducted Emissions Site Registration Number: C-1608

2.3 Radiated Emissions Test Site Description

2.3.1 Semi-Anechoic Chamber Test Site

The Semi-Anechoic Chamber Test Site consists of a 20' x 30' x 18' shielded enclosure. The chamber is lined with Toyo Ferrite Grid Absorber, model number FFG-1000. The ferrite tile grid is 101 x 101 x 19mm thick and weighs approximately 550 grams. These tiles are mounted on steel panels and installed directly on the inner walls of the chamber.

The turntable is 150cm in diameter and is located 160cm from the back wall of the chamber. The chamber is grounded via 1 - 8' copper ground rod, installed at the center of the back wall, it is bound to the ground plane using 3/4" stainless steel braided cable.

The turntable is all steel, flush mounted table installed in an all steel frame. The table is remotely operated from inside the control room located 25' from the range. The turntable is electrically bonded to the surrounding ground plane via steel fingers installed on the edge of the turn table. The steel fingers make constant contact with the ground plane during operation.

Behind the turntable is a 3' x 6' x 4' deep shielded pit used for support equipment if necessary. The pit is equipped with 1 - 4" PVC chases from the turntable to the pit that allow for cabling to the EUT if necessary. The underside of the turntable can be accessed from the pit so cables can be supplied to the EUT from the pit.

A diagram of the Semi-Anechoic Chamber Test Site is shown in Figure 2.3-1 below:

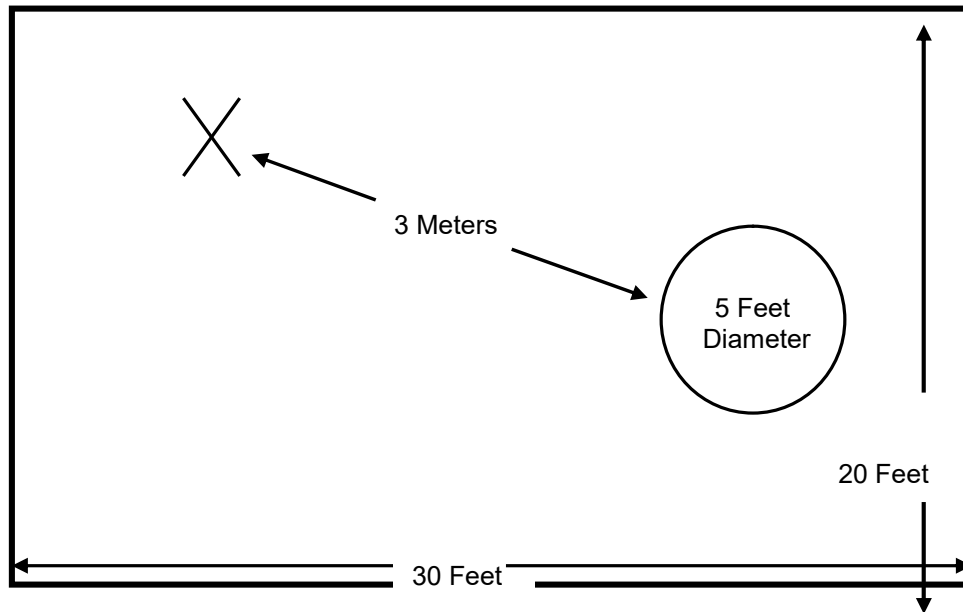

Figure 2.3-1: Semi-Anechoic Chamber Test Site

3 APPLICABLE STANDARD REFERENCES

The following standards were used:

- ❖ ANSI C63.10-2013: American National Standard of Procedures for Compliance Testing of Unlicensed Wireless Devices.
- ❖ IEEE C95.3-2002: IEEE Recommended Practice for Measurements and Computations of Radio Frequency Electromagnetic Fields with Respect to Human Exposure to Such Fields, 100 kHz to 300 GHz.
- ❖ US Code of Federal Regulations (CFR): Title 47, Part 1, Subpart I: Procedures Implementing the National Environmental Policy Act of 1969, 2017
- ❖ FCC KDB 447498 D01 General RF Exposure Guidance v06, Oct. 23, 2015.
- ❖ ISED Canada Radio Standards Specification: RSS-102 – Radio Frequency (RF) Exposure Compliance of Radiocommunications Apparatus (All Frequency Bands), Issue 5, March 2015.

4 LIST OF TEST EQUIPMENT

The calibration interval of test equipment is annually or the manufacturer's recommendations. Where the calibration interval deviates from the annual cycle based on the instrument manufacturer's recommendations, it shall be stated below.

Table 4-1: Test Equipment

AssetID	Manufacturer	Model #	Equipment Type	Serial #	Last Calibration Date	Calibration Due Date
RE137	ETS-Lindgren	HI-6005	Probes	23667	8/31/2016	8/31/2017

NOTE: All test equipment was used only during active calibration cycles.

5 SUPPORT EQUIPMENT

Table 5-1: Support Equipment – Radiated Emissions

Item	Equipment Type	Manufacturer	Model/Part Number	Serial Number
1	Power Supply	TRIAD	WSU120-1000	N/A

Table 5-2: Cable Description – Radiated Emissions

Cable	Cable Type	Length	Shield	Termination
A	DC Power Cable	1.75 m	No	EUT to Power Supply
B	RF Cable	1.85 m	Yes	EUT to Antenna

6 EQUIPMENT UNDER TEST SETUP BLOCK DIAGRAM

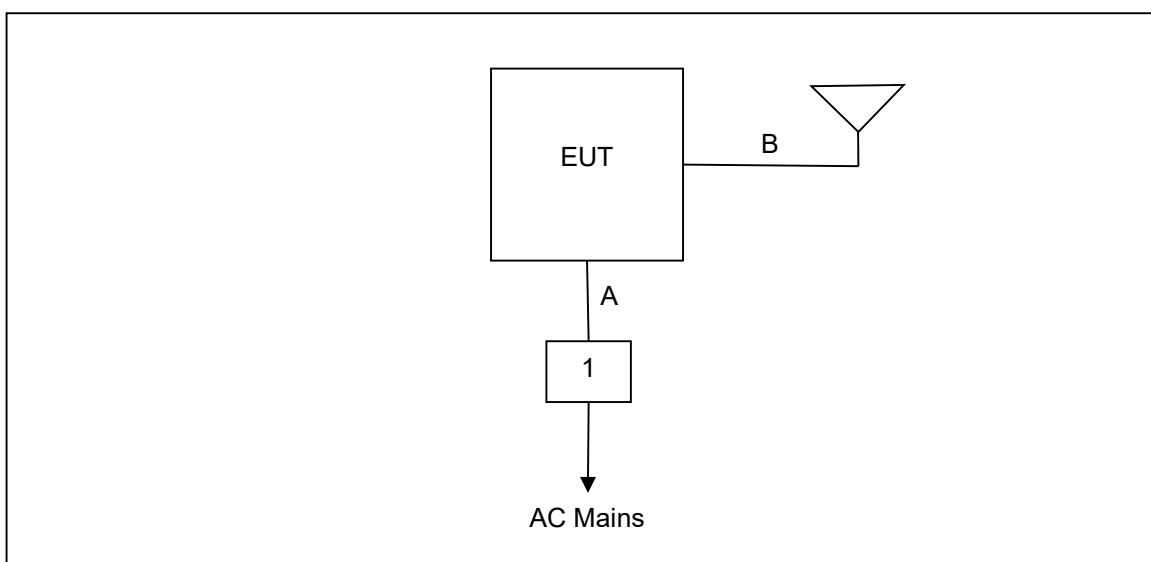

Figure 6-1: Test Setup Block Diagram

7 SUMMARY OF TESTS

Along with the tabular data shown below, plots were taken of all signals deemed important enough to document.

7.1 Maximum Permissible Exposure – FCC: Section 1.1310; ISED Canada: RSS-102 4

7.1.1 Measurement Procedure

The EUT was placed on a non-conductive platform in the center of the turntable at a height of 1.5 meters above the ground plane. The measurement probe was located 20 centimeters away from the EUT on an adjustable antenna mast. The EUT was rotated through 360 degrees so that the maximum radiated emissions level would be detected. The mast was adjusted until the evaluated results are less than 10% of the applicable limit. Once a stable reading was obtained, the maximum was recorded. The azimuth and elevation leading to the direction of maximum exposure was identified. The evaluation points in the horizontal plane were along radials extending from the antenna axis 45 degrees apart starting from the direction of maximum exposure.

7.1.2 Measurement Results

Performed by: Ryan McGann

Table 7.1.2-1: Maximum Permissible Exposure – 900MHz Radio – X-orientation

Frequency (MHz)	Distance cm	Azimuth degrees	Elevation cm	Probe Display V/m	Probe Factor	Field Strength V/m	Power Density mW/cm ²	FCC Limit mW/cm ²	ISED Canada Limit mW/cm ²	Result
915.2	20	0	303	8.027	1.02	8.188	0.018	0.610	0.277	PASS
915.2	20	45	298	6.823	1.02	6.959	0.013	0.610	0.277	PASS
915.2	20	90	292	6.791	1.02	6.927	0.013	0.610	0.277	PASS
915.2	20	135	290	5.486	1.02	5.596	0.008	0.610	0.277	PASS
915.2	20	180	288	6.323	1.02	6.449	0.011	0.610	0.277	PASS
915.2	20	225	287	6.485	1.02	6.615	0.012	0.610	0.277	PASS
915.2	20	270	290	5.993	1.02	6.113	0.010	0.610	0.277	PASS
915.2	20	315	300	6.864	1.02	7.001	0.013	0.610	0.277	PASS

Table 7.1.2-2: Maximum Permissible Exposure – 900MHz Radio – Y-orientation

Frequency (MHz)	Distance cm	Azimuth degrees	Elevation cm	Probe Display V/m	Probe Factor	Field Strength V/m	Power Density mW/cm ²	FCC Limit mW/cm ²	ISED Canada Limit mW/cm ²	Result
915.2	20	0	301	7.999	1.02	8.159	0.018	0.610	0.277	PASS
915.2	20	45	221	6.488	1.02	6.618	0.012	0.610	0.277	PASS
915.2	20	90	292	6.327	1.02	6.454	0.011	0.610	0.277	PASS
915.2	20	135	288	5.297	1.02	5.403	0.008	0.610	0.277	PASS
915.2	20	180	288	6.420	1.02	6.548	0.011	0.610	0.277	PASS
915.2	20	225	290	6.633	1.02	6.766	0.012	0.610	0.277	PASS
915.2	20	270	288	5.939	1.02	6.058	0.010	0.610	0.277	PASS
915.2	20	315	302	6.854	1.02	6.991	0.013	0.610	0.277	PASS

Table 7.1.2-3: Maximum Permissible Exposure – 900MHz Radio – Z-orientation

Frequency (MHz)	Distance cm	Azimuth degrees	Elevation cm	Probe Display V/m	Probe Factor	Field Strength V/m	Power Density mW/cm ²	FCC Limit mW/cm ²	ISED Canada Limit mW/cm ²	Result
915.2	20	0	301	7.966	1.02	8.125	0.018	0.610	0.277	PASS
915.2	20	45	295	6.73	1.02	6.865	0.012	0.610	0.277	PASS
915.2	20	90	292	6.614	1.02	6.746	0.012	0.610	0.277	PASS
915.2	20	135	291	5.336	1.02	5.443	0.008	0.610	0.277	PASS
915.2	20	180	289	6.219	1.02	6.343	0.011	0.610	0.277	PASS
915.2	20	225	287	6.354	1.02	6.481	0.011	0.610	0.277	PASS
915.2	20	270	293	5.708	1.02	5.822	0.009	0.610	0.277	PASS
915.2	20	315	301	6.927	1.02	7.066	0.013	0.610	0.277	PASS

8 ESTIMATION OF MEASUREMENT UNCERTAINTY

The expanded laboratory measurement uncertainty figures (U_{Lab}) provided below correspond to an expansion factor (coverage factor) $k = 1.96$ which provide confidence levels of 95%.

Parameter	U_{lab}
Electric Field	39.12%

9 CONCLUSION

In the opinion of TÜV SÜD America, Inc. the OW1, manufactured by Itron, Inc. meets the requirements of FCC Part 1 subpart I and Innovation, Science, and Economic Development Canada's Radio Standards Specification RSS-102 for the tests documented in this test report.

END REPORT