

# configuration

HP

NetServer Rack

Configuration



Evolving  
a higher  
level of  
protection

April 1999

This configuration guide is intended to allow you to:

- Calculate the power requirements, weight and stability of your rack solution
- Determine the number of racks required to rackmount your equipment
- Identify the key features of racks and accessory products
- Generate a complete custom list of rack and accessories required

HP strongly recommends the use of the HP NetServer Rack Assistant configuration software to configure your rack solution. This free tool is available from the world wide web at <http://www.hp.com/go/netserver>



If, for any reason, you are not able to use the Rack Assistant software, follow the steps below to create your custom rack solution. For details of each step, see the Configuration Details on pages 12 and 13.

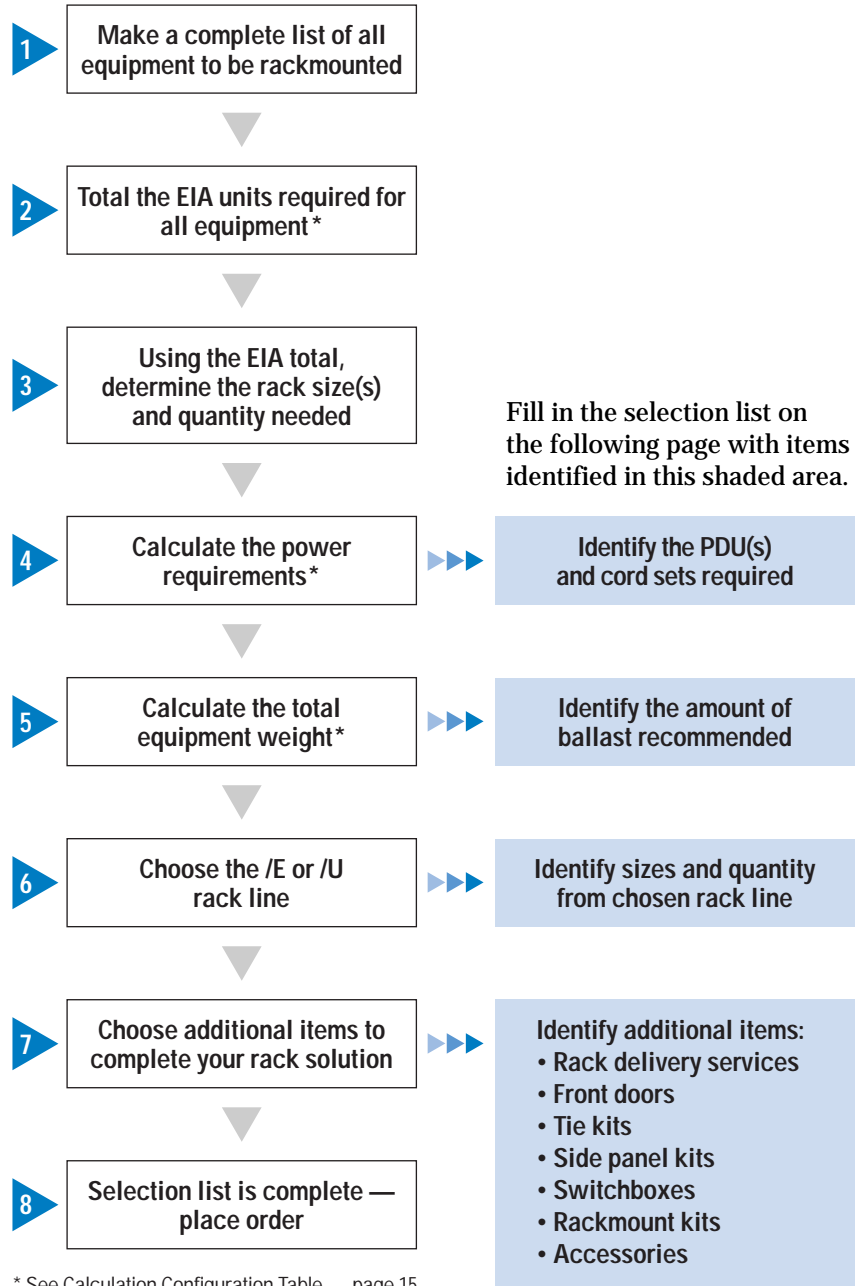

\* See Calculation Configuration Table — page 15

Product information is also available at:

<http://www.hp.com/go/enclosures>

## Rack System Selection List for NetServers

	Description	Product Number	Quantity	For details, see page
<b>HP Rack System Model</b>	HP Rack System/E41	J1500A	_____	4
	HP Rack System/E33	J1501A	_____	4
	HP Rack System/E25	J1502A	_____	4
	HP Rack System/U33	J1466A	_____	5
	HP Rack System/U25	J1464A	_____	5
<b>Delivery Services</b>	Inside delivery service	J1543A	_____	4
	Coordinated shipment service	J1544A	_____	5
<b>Front Doors</b>	Front door for /E41	J1509A	_____	6
	Front door for /E33 or /U33	J1510A	_____	6
	Front door for /E25 or /U25	J1511A	_____	6
<b>Tie Kits</b>	Tie Kit for /E41	J1512A	_____	6
	Tie Kit for /E33 or /U33	J1513A	_____	6
<b>Side Panel Kits</b>	Side panel kit for /E41	J1506A	_____	6
	Side panel kit for /E33	J1507A	_____	6
	Side panel kit for /E25	J1508A	_____	6
<b>Power Distribution</b>				
PDU's	100-240V, 10 amps	E7670A	_____	7
	100-240V, 16 amps	E7671A	_____	7
	Bundle (1 ea. E7670A, E7671A, E7742A)	E7672A	_____	7
	100-240V, 16 amps	E7674A	_____	7
	100-127V, 16 amps	E7675A	_____	7
	100-240V, 16 amps	E7676A	_____	7
Cord Sets	100-127V NEMA (to wall), C19 to 5-20P	E7802A	_____	7
	200-240V IEC (to wall or UPS), C19 to L6-20P	E7803A	_____	7
	100-240V IEC (to server, storage or UPS), C19 to C20	E7804A	_____	7
	200-240V IEC (to UPS), C19 to L6-30P	E7805A	_____	7
	100-240V (to wall or UPS), C19 to unterminated	E7806A	_____	7
	250V IEC for LX Pro/LXe Pro (to server, storage or UPS), C14 to C15	E7807A	_____	7
	240V IEC (to European wall), C19 to IEC309	E7808A	_____	7
	240V IEC (to European wall), C19 to CEE7/7	E7809A	_____	7
	240V IEC (to server, storage or UPS), C13 to C14	E7742A	_____	7
	127V NEMA (to server, storage or UPS), C13 to 5-15P	E7743A	_____	7
	240V IEC (to server, storage or UPS)	E7798A	_____	7
	<b>Switchboxes</b>	4-port switchbox, plus 4 cable sets	J1493B	_____
8-port switchbox, plus 8 cable sets		J1497B	_____	9
<b>Rackmount Kits</b>				
Universal	Keyboard rackmount kit	J1518A	_____	8
	Monitor rackmount kit	J1519A	_____	8
	Plain shelf rackmount kit	J1520A	_____	8
Servers	NetServer LXr Pro Conversion Kit*	J1523A	_____	9
	NetServer LX/LXe	J1455B	_____	9
	NetServer LCII	J1456B	_____	9
	NetServer E	J1496C	_____	9
	<i>Rackmount kit included with product</i> NetServer LH 3r NetServer LXr Pro and LXr Pro8	Included Included		
Storage	NetServer Storage System/6	J1492B	_____	9
	<i>Rackmount kit included with product</i> NetServer Storage System/8	Included or C2788B*	_____	9
	HP SureStore DLT Library 4115r and 4215r	Included		
<b>Accessories</b>	Computer rails	C2788B	_____	9
	Ballast	C2790A	_____	10
	Filler panels (qty 6)	J1514A	_____	10
	Cable guide (qty 2)	E7723B	_____	10
	Mounting hardware	J1522A	_____	11
	Lift hooks (qty 4)	J1521A	_____	11
	Rail spacers (qty 4)	J1516A	_____	11

\*Needed only to mount in Rack System/E or Rack System/U

## HP Rack System/E

Advanced, full-featured rack for the most demanding rackmount requirements. Electronic Industry Association (EIA) standard compliant.

### Key Features

- Extendible top allows for an additional 8U of vertical space to be added to an existing rack
- Optimum ventilation including perforated rear door and fully perforated top
- Ships and moves fully integrated, up to 1800 lbs.
- Retractable anti-tip foot extends from front or rear
- Numbered columns for easy integration
- Available in three sizes: 41U, 33U, 25U

### Use the Rack System/E when you want:

- Maximum configuration flexibility
- To mount equipment up to 2000 lbs.
- Optimum ventilation capacity
- Vertical extension capability to an existing rack
- Optimum stability while servicing slide-mounted equipment

### Features

- 1 Fully perforated top
- 2 Lockable perforated rear door, 63% airflow
- 3 Numbered columns (numbered from bottom to top)
- 4 Bi-directional, retractable anti-tip foot
- 5 Casters
- 6 Leveling feet
- 7 Solid base

### Optional

- 8 Modular side panels
- 9 Lift hooks
- 10 Filler panels
- 11 Perforated front door, 63% airflow
- 12 Ballast

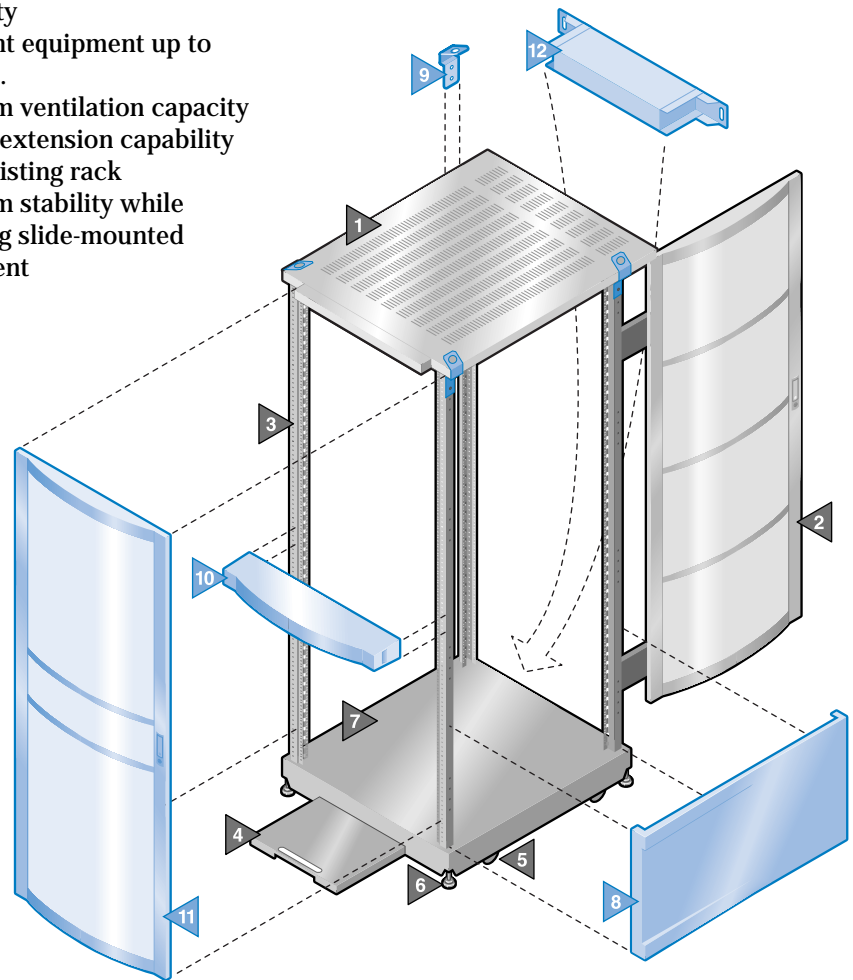

Product Numbers		J1500A	J1501A	J1502A
EIA Units		41U	33U	25U
Caster rating		1000 lbs per caster	1000 lbs per caster	1000 lbs per caster
Color	Top and rear door	Quartz gray	Quartz gray	Quartz gray
	Columns and base	Slate gray	Slate gray	Slate gray
Weight	Empty rack	73.5 kg (162 lbs)	69 kg (153 lbs)	65 kg (144 lbs)
	Packaged	142.4 kg (314 lbs)	132.9 kg (293 lbs)	124.3 kg (274 lbs)
	Rear door	13.2 kg (29 lbs)	12.7 kg (28 lbs)	8.6 kg (19 lbs)
Dimensions	Rack (w x d x h)	23.5 in x 36.5 in x 77.5 in	23.5 in x 36.5 in x 63.5 in	23.5 in x 36.5 in x 49.5 in
	Rack packaged	40 in x 48 in x 86.5 in	40 in x 48 in x 72.5 in	40 in x 48 in x 58.5 in
	(w x d x h)			

## Delivery Services

### J1543A Inside Delivery Service — Available in the US only

Provides for delivery of rack to the installation site at the specified shipping address and removal of packaging materials upon customer's request. Order one part number per rack. 1–2 week delivery time.

## HP Rack System/U

Utility rack for basic rackmounting needs.  
Electronic Industry Association (EIA) standard compliant.

### Key Features

- Ships and moves fully integrated, up to 1000 lbs.
- Numbered columns for easy integration
- Adequate ventilation for NetServer systems
- One-piece removable side panels
- Perforated rear door, solid top
- Bolt-on anti-tip foot
- Available in two sizes: 33U, 25U

### Use the Rack System/U when you want:

- Basic rack features
- To mount equipment with no special ventilation requirements

### Features

- 1 Solid top
- 2 Lockable perforated rear door, 63% airflow
- 3 Numbered columns (numbered from bottom to top)
- 4 Bolt-on anti-tip foot
- 5 Side panels
- 6 Casters
- 7 Leveling feet
- 8 Solid base
- 9 Cable guide

### Optional

- 10 Filler panels
- 11 Ballast
- 12 Perforated front door, 63% airflow

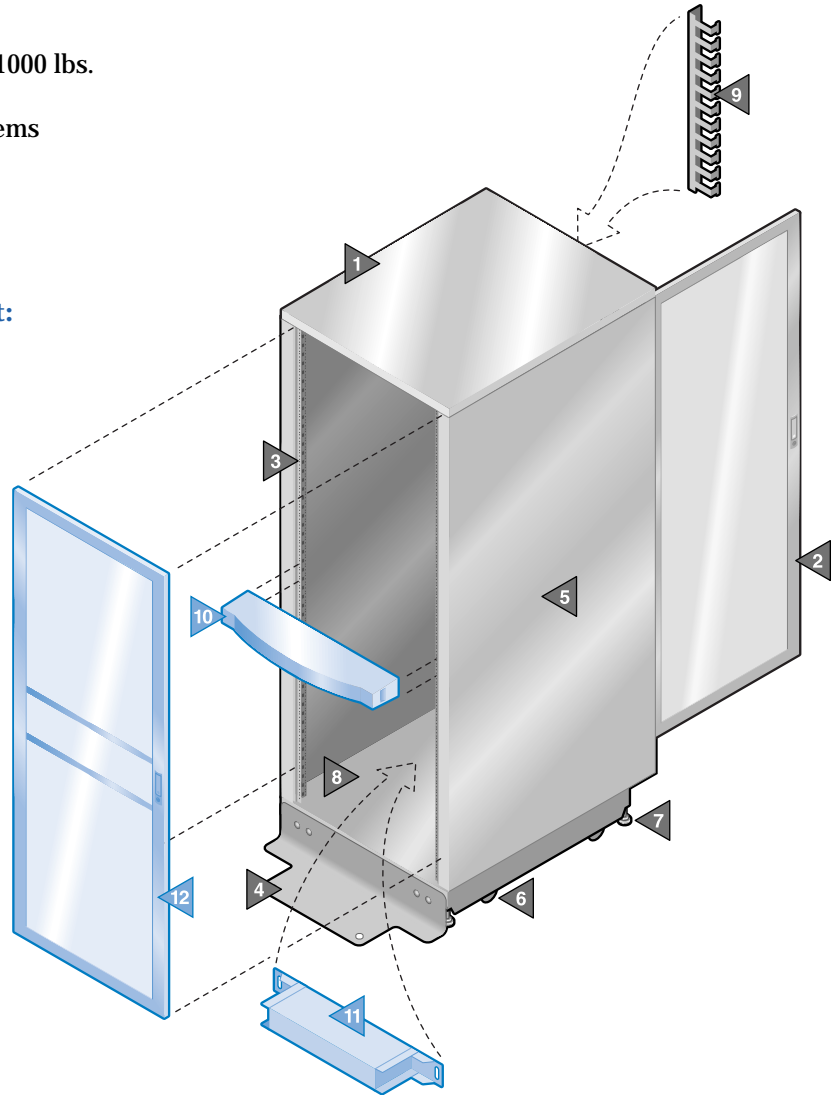

Product Numbers	J1466A	J1464A
EIA Units	33U	25U
Caster rating	225 lbs per caster	225 lbs per caster
Color	Top cap, columns, side panels and rear door Quartz gray	Quartz gray
Weight	Empty rack Packaged Rear door Side panels	84.4 kg (186 lbs) 108 kg (238 lbs) 7.6 kg (16 lbs) 12.7 kg (28 lbs)
Dimensions	Rack (w x d x h) Rack packaged (w x d x h)	23.4 in x 36.5 in x 63.2 in 40 in x 48 in x 72.5 in
		23.4 in x 36.5 in x 49.2 in 40 in x 48 in x 58.5 in

### J1544A Coordinated Shipment Delivery Service — Available in the US only

Provides for rack and accessories to arrive within a 3-day period of each other at the customer location. Accessories will arrive boxed together in one shipment. Order one part number per order. 1–2 week delivery time.

## Front Doors

### Key Features

- Perforated, 63% airflow
- Lockable latch for equipment security
- All equipment is visible through the perforations
- Mounting hardware included

### Use a front door to:

- Secure equipment from unwelcome access
- Provide a clean aesthetic finish to the rack



Front Doors

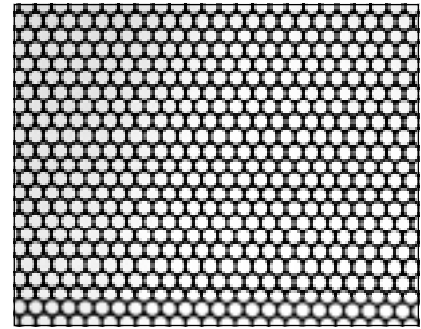

Perforation Material

Product No.	Use with
J1509A	/E41
J1510A	/E33 and /U33
J1511A	/E25 and /U25

## Tie Kits

### Key Features

- Easily installed without removing or turning off rackmounted equipment
- Can connect racks of different sizes together (41U and 33U)
- Can connect /E and /U racks together
- Increases security of equipment by reducing side access
- Mounting hardware included

### Use a tie kit to:

- Connect two or more racks together



Tie Kit Contents

Product No.	Use with
J1512A	/E41
J1513A	/E33 and /U33

◀ This tie kit can also be used to connect the /E41 with either an /E33 or /U33.

## Side Panels

Use only with the Rack System/E

### Key Features

- Snap on/off design, requires no tools for installation or removal
- Kits contain the panels needed to cover both sides of the rack
- Only one side panel kit is required for a tied together rack configuration

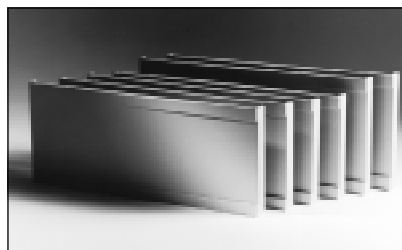

/E25 Side Panel Kit

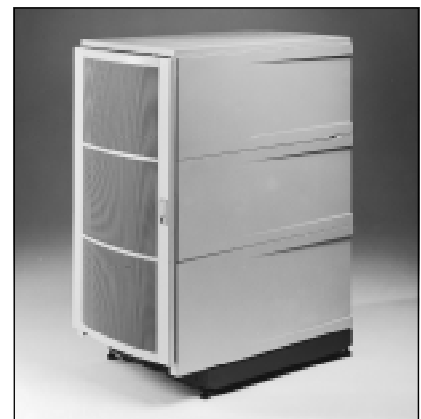

/E25 Side Panels Installed

### Use side panels to:

- Gain easy side access just where you need it. Security is maintained if a front and rear are installed
- Provide a finished clean look to the rack solution

Product No.	Use with*	Kit contains
J1506A	/E41	Qty: 2 9U side panels, Qty: 8 8U side panels
J1507A	/E33	Qty: 2 9U side panels, Qty: 6 8U side panels
J1508A	/E25	Qty: 2 9U side panels, Qty: 4 8U side panels

\* Side panels come standard with the Rack System/U

## Modular Power Distribution Units (PDUs)

### Key Features

- Up to four PDUs per rack
- Mounting hardware included
- Can be mounted vertically or horizontally on columns

### Use a PDU to:

- Conveniently provide power to rackmounted equipment



E7675A Contents



E7672A Contents



### Plugs



### Outlets

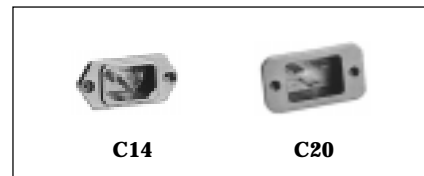

### Inlets

## PDUs

Product Number	Voltage	Max Current	Outlets	Inlets	Certification
E7670A	100-240 (Univ)	10 amps	10 IEC320 C13	1 IEC320 C14	UL, C-UL, TUV-R GS
E7671A	100-240 (Univ)	16 amps	6 IEC320 C13, 2 IEC320 C19	1 IEC320 C20	UL, C-UL, TUV-R GS
E7672A*	100-240 (Univ)	16 amps	16 IEC320 C13, 2 IEC320 C19	1 IEC320 C20	UL, C-UL, TUV-R GS
E7674A	100-240 (Univ)	16 amps	7 IEC320 C13, 1 IEC320 C19	1 IEC320 C20	UL, C-UL, TUV-R GS
E7675A†	100-127	16 amps	9 NEMA 5-15R, 1 IEC320 C13	1 IEC320 C20	UL, C-UL
E7676A	100-240 (Univ)	16 amps	10 IEC320 C13	1 IEC320 C20	UL, C-UL, TUV-R GS

\* E7672A is a bundled set of 1ea. E7670A, E7671A and E7742A jumper cable.

† For 110V environments, HP recommends the use of the E7675A PDU because NetServers ship with a power jumper cable compatible with E7675A receptacles.

## Cords Sets

Product Number	Type	Cord Length	Plug	Compatible APC UPS**
E7802A	100-127V NEMA (to wall)	4.5m (177.2in)	C19 to 5-20P	NS2200RM3U
E7803A	200-240V IEC (to wall or UPS)	4.5m (177.2in)	C19 to L6-20P	NS3000RMT3U
E7804A	100-240V IEC (to server, storage or UPS)	4.0m (157.5in)	C19 to C20	NS2200RMI3U
E7805A	200-240V IEC (to UPS)	4.5m (177.2in)	C19 to L6-30P	—
E7806A	100-240V IEC (to wall or UPS)	4.5m (177.2in)	C19 to unterminated	—
E7807A	250V IEC for LX Pro/Lxe Pro (to server, storage or UPS)	0.76m (29.9in)	C14 to C15	—
E7808A	240V IEC (to European wall)	4.5m (177.2in)	C19 to IEC309	—
E7809A	240V IEC (to European wall)	4.5m (177.2in)	C19 to CEE7/7	—
E7742A	240V IEC (to server, storage or UPS)	2.5m (98.4in)	C13 to C14	—
E7743A	127V NEMA (to server, storage or UPS)	2.5m (98.4in)	C13 to 5-15P	—
E7798A	240V IEC (to server, storage or UPS)	2.5m (98.4in)	C19 to C20	—

\*\* APC UPS products are sold and supported by APC and APC resellers (not orderable from HP).

## Universal Rackmount Kits

### Keyboard Rackmount Kit Key Features

- Retracts into the rack when not in use
- Easy installation
- Fits all standard keyboards
- Mounting hardware included

#### Use the keyboard kit to:

- Mount a keyboard and mouse within a rack

Note: These kits do not include a keyboard or mouse.

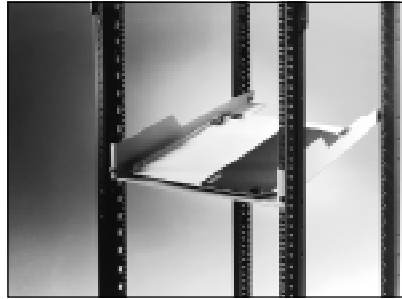

J1518A Installed in Rack

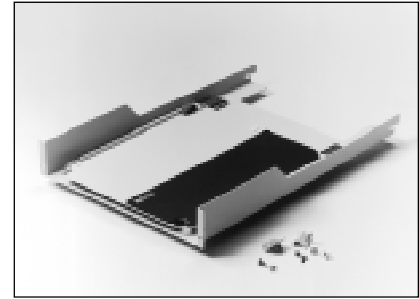

Keyboard Rackmount Kit Contents

Product No.	Use with	Kit contains	EIA Units
J1518A	All HP Racks	Keyboard kit assembly, mounting hardware	2

### Monitor Rackmount Kit Key Features

- Snap-in design
- Easy installation
- Mounting hardware included

#### Use the monitor rackmount kit to:

- Mount a 14" – 19" monitor within a rack

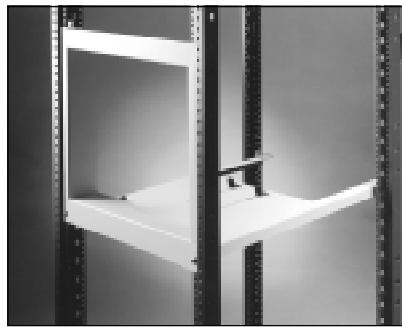

J1519A Installed in Rack

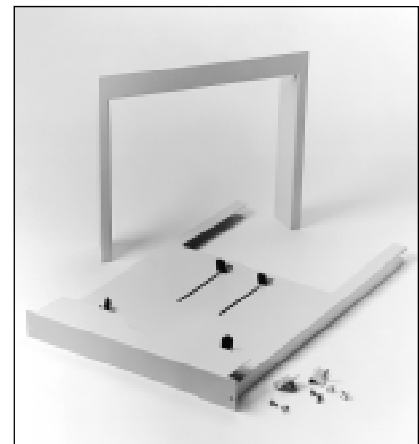

Monitor Rackmount Kit Contents

Product No.	Use with	Kit contains	EIA Units
J1519A	All HP Racks	Monitor base, snap-in front bezel, mounting hardware	11

### Plain Shelf Key Features

- Supports up to 68 kg (150 lbs)
- Easy installation
- Mounting hardware included
- Attractive quartz color

#### Use a shelf to:

- Provide a stationary surface in a rack for products without a custom rackmount kit.

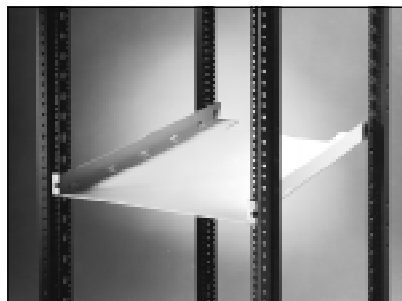

J1520A Installed in Rack

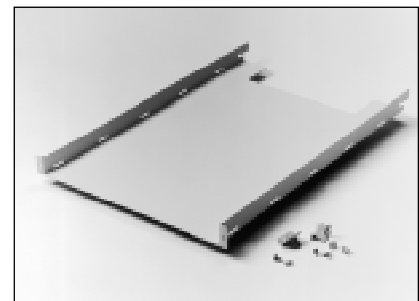

Shelf Contents

Product No.	Use with	Kit contains	EIA Units
J1520A	All HP Racks	Stationary shelf, mounting hardware	1



## Server Rackmount Kits Key Features

- Designed to custom fit the server
- Mounting hardware included
- Easy installation

### Use the server rackmount kit to:

- Mount a server in a rack



**LH 3r Installed in Rack**



**J1455B Rackmount Kit Contents**

Product No.	Use with	Rackmounted server	EIA Units
J1455B	All HP Racks	LX Pro/LXe Pro	14
J1456B	All HP Racks	LC II	14
J1496C	All HP Racks	E Series	11
J1523A	Only for /E and /U line	LXr Pro	7
Rackmount kit is bundled with server, no separate purchase necessary.			
	All HP Racks	LH 3r	8
	All HP Racks	LXr Pro8	10

## Storage Rackmount Kits Key Features

- Designed to custom fit the storage system
- Mounting hardware included
- Easy installation

### Use the storage rackmount kit to:

- Mount a storage system in a rack



**C2788B Contents**

**J1492B Contents**

Product No.	Use with	Rackmounted Storage System	EIA Units
J1492B	All HP Racks	Storage System/6	11
C2788B	Only for /E and /U line	Storage System/8	3
Needed only to mount in Rack System /E or RackSystem /U			

## Switchboxes Key Features

- Available in 4-port and 8-port models
- Appropriate quantity of 3.66m (12 ft) cable sets are included
- Software controlled

### Use a switchbox to:

- Control multiple NetServers from a single monitor, keyboard and mouse



**J1493B Kit Contents**



**J1497B Kit Contents**

Product No.	Description	Use with	Kit contains	EIA Units
J1493B	4-port console switchbox	All HP racks	4-port switchbox, 4 sets of mouse, keyboard, and monitor cables and mounting hardware	1 unit – front mount; 0 unit – rear mount
J1497B	8-port console switchbox	All HP racks	8-port switchbox, 8 sets of mouse, keyboard, and monitor cables and mounting hardware	1 unit – front mount; 0 unit – rear mount

## Ballast

### Key Features

- Mounts easily to the rear columns
- Mounting hardware included

### Use ballast to:

- Provide an added measure of stability for servicing slide-mounted equipment.



**C2790A Installed in Rack**

Product No.	Use with	Kit contains
C2790A	All HP Racks	30 lb. steel ballast, mounting hardware

## Filler Panels

### Key Features

- Easy snap-in design
- Contemporary industrial design
- No mounting hardware required

### Use filler panels to:

- Attractively cover unused rack space.

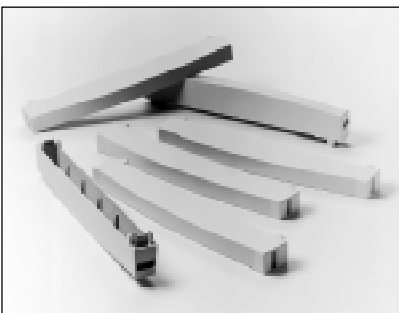

**Filler panels**

Product No.	Use with	Kit contains	EIA Units
J1514A	/E and /U racks only	6 filler panels	1 EIA unit per filler panel

## Cable Guide

### Key Features

- Sturdy 16-gauge metal will support heavy cables
- Mounts vertically or horizontally on rear columns
- Quick and easy installation

### Use a cable guide to:

- Organize routing of data and power cables

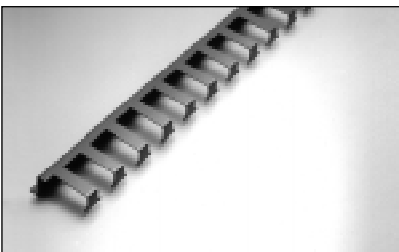

**Cable Guide**

Product No.	Use with	Kit contains
E7723B	All HP Racks	2 19" cable guides, mounting hardware

## Lift Hooks

### Key Features

- Each hook can support 500 lbs.
- Easy installation
- No additional hardware required

### Use lift hooks to:

- Lift a rack weighing up to 2000 lbs. for repositioning

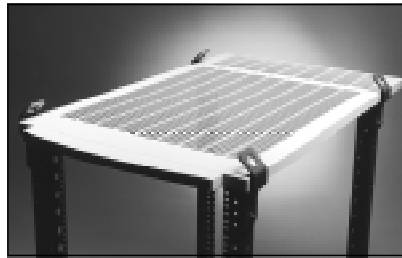

**J1521A Installed on Rack**

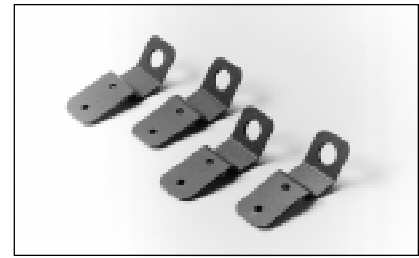

**Lift Hooks**

Product No.	Use with	Kit contains
J1521A	Rack System/E only	4 lift hooks

## Rail Spacers

The Rack System/E and /U design includes a recess of 1/2 inch on the inside mounting surface of each column to support mounting full-width products. Spacers are used with old legacy rackmount kits to fill the 1/2 inch recess gap.

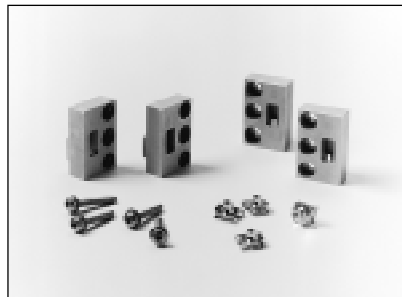

**Spacers**

### Key Features

- Die-cast aluminum construction
- Mounting hardware included

### Use spacers to:

- Accommodate legacy rackmount kits in the HP Rack System/E and /U.

Product No.	Use with	Kit contains	Use with old legacy products
J1516A	Rack System /E and /U only	2 left spacers, 2 right spacers, mounting hardware	J1496A NetServer E rackmount kit J1492A NetServer SS/5 rackmount kit J1456A NetServer LCII rackmount kit

## Hardware

### Use extra hardware to:

- Keep extra mounting hardware at hand

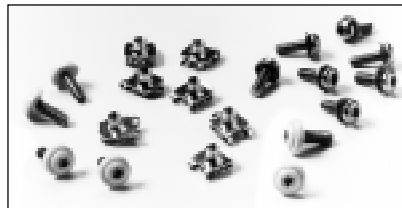

**Hardware**

Product No.	Use with	Kit contains
J1522A	All HP racks and rack accessories	10 Torx T25 decorative screws, 10 Torx T25 non-decorative screws with lock washers, 20 U-type, sheet metal nuts

### 1 Generate a complete list of products to be rackmounted.

Don't leave anything out. If you know you'll be using more than 1 rack, list the items to be included in each rack.

### 2 Determine the EIA units required for all equipment.

Each rack has a specific amount of vertical mounting space which is measured in EIA units (1 EIA unit is equal to 1.75 inches or 45.44 mm). The rack title is indicative of this measurement (i.e., Rack System/E25 has 25 EIA units of vertical mounting space). Using the Calculation Configuration table on page 15, list the EIA units required for each product listed in step 1.

If there is a product to be rackmounted not listed on page 15, rackmount it on a plain shelf. In this case, calculate the height of the product into EIA units (1 = 1.75 in or 44.45 mm) and add 1 additional EIA unit for the height of the shelf. Add together the EIA units required for your rack solution.

### 3 Determine the rack size(s) and quantity needed.

- Up to 25U: choose either the Rack System/E25 or the Rack System/U25
- 26U to 33U: choose either the Rack System/E33 or Rack System/U33
- 33U to 41U: choose the Rack System/E41
- More than 41U: any combination of the /E25, /E33, /E41 or /U25, /U33  
(Note: You can mix and even tie-together, the /E and /U lines. However, these lines do not have the same look and the rack solution aesthetics will be compromised.)

#### Note on multiple racks:

If multiple racks are required, you may want to connect them with a tie-together kit. Make sure to use the appropriate size tie kit. A 33U tie kit can connect a 41U and a 33U together. No tie kit is available for a 25U rack.

### 4 Calculate the power requirements.

The PDU is a rackmounted power strip with multiple power receptacles. Rack components are plugged into PDU receptacles. The number of components placed in a rack impacts the quantity of power distribution units required and is affected by:

- facility power voltage (100-120V or 200-240V)
- number of power receptacles needed
- mounted equipment current (Amperes)

#### 1. Determine the facility power voltage that will be used.

#### 2. Count the quantity of receptacles needed from the PDU(s). (The Rack Storage/8 and Rack Storage/12 requires 2 power receptacles)

#### 3. Total the Amperes required for all components in each rack.

(use the Configuration Calculation table on page 15 for this information) The total amperes of devices plugged into a PDU cannot exceed the 10A or 16A rating of the PDU. When the 10A PDU is plugged into the 16A PDU, the total current of the two PDUs cannot exceed 16A. If the result is greater than the maximum PDU amperage, order an additional PDU. Amperage can be determined using the following formula (For 110V current, use 104 as the adjusted voltage. For 208V current, use 180. For 230V current, use 198.)

$$\text{Amps} = \frac{\text{Total Watts}}{\text{Adjusted Voltage}}$$

See Configuration Calculation table on page 15 for watts.

#### 4. Determine the PDU(s) and cord sets.

- Using the table on page 7, find the appropriate PDU which is determined by the voltage and number receptacles required for the rack solution (per rack).
- A list of cord sets is also available on page 7. Choose the power cord with the appropriate plug attached (to choose the correct plug, you must know the type of wall/UPS receptacle to be used).
- Jumper cables are not needed for rack-optimized products.

#### Note on multiple racks:

No power or calculations can be made between racks. Calculating total power requirements does not allow for cross connecting power between racks. Cross connecting power between racks could pose a serious threat of injury to personnel or damage to components.

### 5 Calculate the total equipment weight.

All racks come with an anti-tip foot for temporary servicing. Ballast offers additional security in case someone forgets to use the anti-tip foot. The calculations below recommend the number of ballasts to buy to prevent tipping if all slide-mounted products are extended at the same time.

## Configuration Details

### Weight and Balance Worksheet:

1. Total the weight of operator serviceable slide-mounted products:

**M1** A = \_\_\_\_\_ lbs; B = \_\_\_\_\_ lbs; C = \_\_\_\_\_ lbs; D = \_\_\_\_\_ lbs; ...

2. Total the weight of all fixed and trained service personnel serviceable products:

**M2** a = \_\_\_\_\_ lbs; b = \_\_\_\_\_ lbs; c = \_\_\_\_\_ lbs; d = \_\_\_\_\_ lbs; ...

3. Calculate the moment for both totals (M1 and M2) from above:

Model	M1	M2
1.25 m	(A + B + C + D ... ) * 1.25 ft	-45.4 ft-lbs + (a + b + c + d + ... ) * 1.00 ft
1.6 m	(A + B + C + D ... ) * 1.25 ft	-92.1 ft-lbs + (a + b + c + d + ... ) * 1.00 ft
1.96m	(A + B + C + D ... ) * 1.25 ft	-136.4 ft-lbs + (a + b + c + d + ... ) * 1.00 ft

M1 = Moment on rack with all operator serviceable slide-mounted products extended.  
M2 = Moment of all fixed and trained personnel serviceable slide-mounted products and rack.  
M2 moment calculations assume a 1.00 ft center of gravity for installed products

If M1 is less than or equal to M2, no additional counter weight is needed.

If M1 is greater than M2, use the formulas below to determine the required counter weight.

Force (in lbs) = (M1 - M2) ft-lbs ÷ 2.46 ft = amount of force required @ 2.46 ft

X = Force (lbs) ÷ 30 lbs = number of C2790A 30 lbs ballast kits to install, where "X" is rounded up to the next highest integer, e.g., 1.2 = 2 ballast kits.

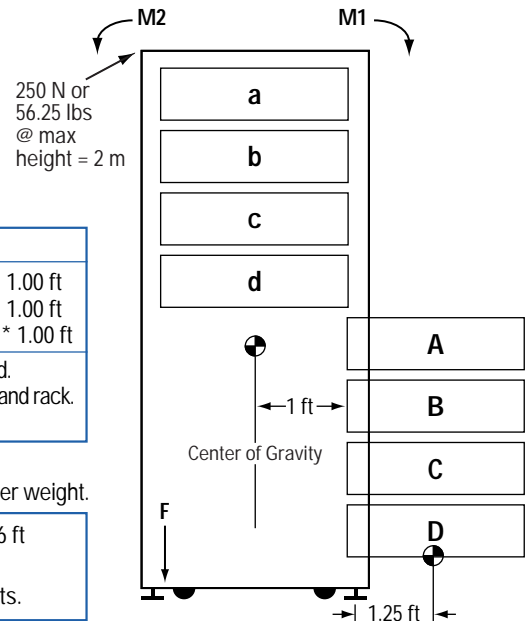

**Note:** You may choose not to install ballast weights if only trained service personnel will perform service, if the anti-tip foot is used during servicing or installation, and not more the one device is extended from the rack at any time.

If using ballast, fill in the selection list on page 3 with the calculated number of ballast required.

**Stability:** Weight is a consideration when stacking the rack. In general, place the heaviest devices near the bottom of the rack for greatest stability and servicing. Put lighter devices and seldom accessed devices (such as monitors and rack-optimized storage modules) near the top of the rack.

6

### Choose between the /E or /U rack line.

Choose the Rack System/E if you answer 'yes' to any of the following questions:

- Will you need to ship rack integrated?
- Do you want the option to increase the rack space by 8U for future growth?
- Is the equipment to be mounted over 1000 lbs.?
- Do you want optimum stability while servicing slide-mounted equipment?
- Do you require between 33U and 41U of vertical mounting space in a single rack?
- Does your equipment require optimum ventilation?

If you did not answer 'yes' to ANY of the above questions, remember the /E line is a full-featured, premium line while the /U line is a basic, utility rack line with limited configuration choices. See pages 4 and 5 for more differentiating details. Fill in the selection list on page 3 with the rack sizes and quantity.

7

### Determine all additional items required.

When applicable, choose the appropriate size. (See the appropriate page for features.)

Fill in the Selection list on page 3 with the quantity of all additional items:

- Delivery services — pages 4 and 5
- Front doors — page 6
- Tie kits — page 6
- Side panel kits (/E line only) — page 6
- PDUs — page 7
- Cord sets — page 7
- Switchboxes — page 7
- Rackmount kits — page 8
- Accessories — pages 9–10

8

### Double check your list.

Go back through your notes and make sure all quantities have been included into the selection list on page 3.

**Congratulations!** You're now ready to place your order.

## Rack System/E

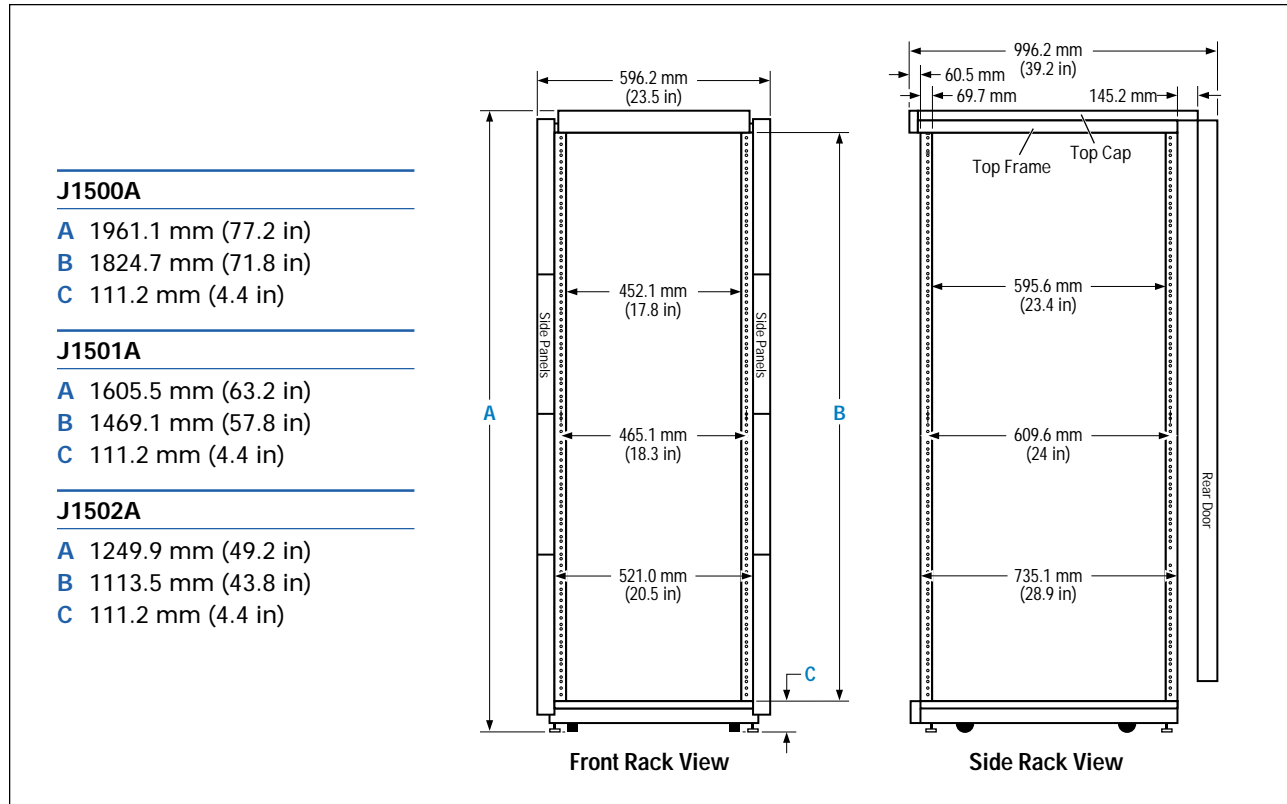

## Rack System/U

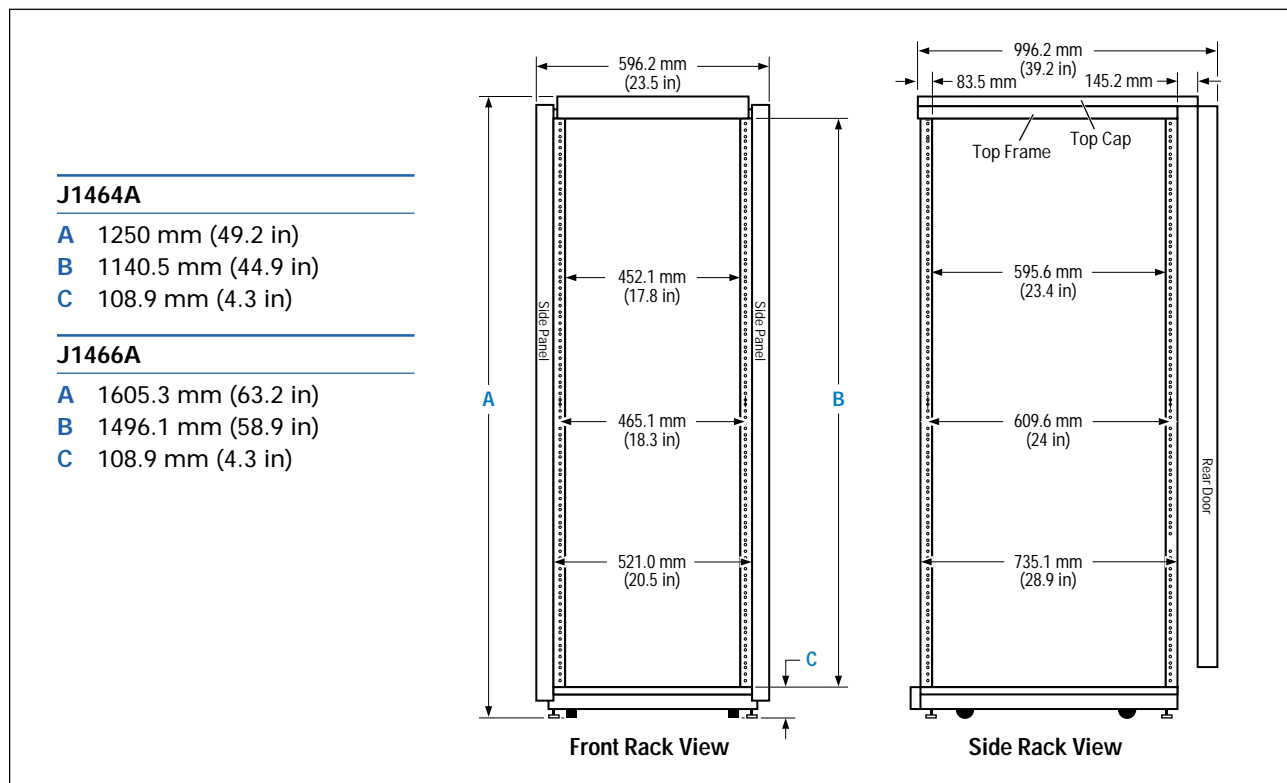

## NetServer Configuration Calculation Table

	Product Number	Description	EIA Units	Wt (lbs)	VA	Watts	Rackmount Kit Required*
Servers		HP NetServer LH 3r	8	150	632	638	Included
		HP NetServer LXR Pro8	10	170	980	989	Included
		HP NetServer LXR Pro	7	90	450	446	J1523A(1)
		HP NetServer LX Pro/LXe Pro	14	187	1455	1225	J1455B
		HP NetServer LHIII/LH Pro/LD Pro	11	70	715	735	J1491B
		HP NetServer LCII	14	55	505	301	J1456B
		HP NetServer E	11	32	245	172	J1496C
Storage	D4902A	Storage System/8	3	80.5	211		Included or C2788B(1)
	D3604B	Storage System/6	11	36	480		J1492B
	C1556A, C1559A	HP SureStore DAT24e, 24GB	3	4.8	6		—
	C6280F	HP SureStore Autoloader 418	5	41	214		—
		HP SureStore DLT Mechanism (40e/70e)	3	14.6	50		C6287J
		HP SureStore DLT Library	8	97	257		Included
UPS	NS2200RM3U	APC Smart-UPS 2200NS, 120V (Available only through APC)	3	102	N/A	1600	Included
	NS2200RMI3U	APC Smart-UPS 2200NS, 230V (Available only through APC)	3	102	N/A	1600	Included
	NS3000RMI3U	APC Smart-UPS 3000NS, 230V (Available only through APC)	3	112	N/A	2250	Included
	NS3000RMT3U	APC Smart-UPS 3000NS, 208V (Available only through APC)	3	112	N/A	2250	Included
Accessories	Up to 19"	Monitor	11	30	125		J1519A
	Any	Keyboard	2	10	—	—	J1518A
	J1493A	Switchbox 4-port	0 or 1	12	100		Included
	J1497A	Switchbox 8-port	0 or 1	12	100		Included
Hubs & Routers	28673A	HP 10:10 LAN Bridge	1	6	96	48	Included
	28682A	HP Fiber-Optic Hub Plus	1	6	96	48	Included
	28688B	HP EtherTwist Hub Plus	1	6	96	48	Included
	J2413A	HP AdvanceStack 100VG Hub-7m	2	10	144	86	Included
	J2415A	HP AdvanceStack 100VG Hub-14	2	10	144	86	Included
	J2601B	HP AdvanceStack 10Base-T Hub-24	2	9	144	86	Included
	J2611B	HP AdvanceStack 10Base-T Hub-16U	1	5	48	24	Included
	J2962A	HP AdvanceStack Power Supply	3	22	1200	720	Included
	J3100B	HP AdvanceStack Switch 2000	7	20	360	216	Included
	J3125A	HP AdvanceStack Switch 200	1	10	96	48	Included
	J3135A	HP AdvanceStack 10Base-T Hub-16U Bundle	1	5	48	24	Included
	J3175A	HP AdvanceStack Switch 208 with 100BaseTX	2	6	192	115	Included
	J3177A	HP AdvanceStack Switch 224 with 100BaseTX	2	9	192	115	Included
	J3200A	HP AdvanceStack 10BT S Hub-12R	2	9	144	86	Included
	J3201A	HP AdvanceStack S Hub-12R w/Mgmt	2	9	144	86	Included
	J3202A	HP AdvanceStack 10BT S Hub-24R	2	9	144	86	Included
	J3203A	HP AdvanceStack S Hub-24R w/Mgmt	2	9	144	86	Included
	J3204A	HP AdvanceStack S Hub-24T	2	9	144	86	Included
	J3205A	HP AdvanceStack S Hub-24T	2	9	144	86	Included
	J3231A	HP Remote 2C and Internet Router Bundle	2	10	180	90	Included
	J3245A	HP AdvanceStack Switch 800T	2	10	190	101	Included

\* Included = Rackmount kit is included with the equipment purchase;  
 — = no custom rackmount kit available, use a plain shelf (J1520A)

(1) Needed only when rackmounting in the Rack System/E or /U

Technical information in this document is subject to change without notice.

© Copyright Hewlett-Packard Company 1998. All Rights Reserved. Reproduction, adaptation, or translation without prior written permission is prohibited, except as allowed under the copyright laws.

**Update Information**

Last Electronic Update — 4/99  
Last Printed Update — 4/99

**5968-0156E**