

ANKER

Live Charged.

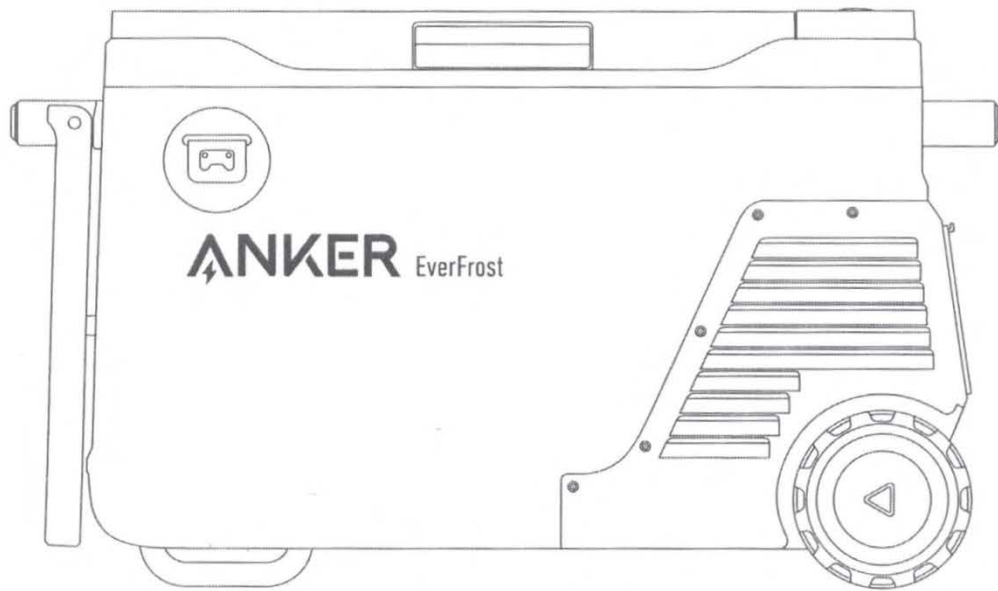

Anker EverFrost Powered Cooler 40

USER MANUAL

Attention



Not permitted on aircraft.

Important Safety Instructions

To reduce the risk of injury, users must read the instruction manual.

WARNING: Read all safety warnings and instructions. Failure to follow the warnings and instructions may result in electric shock, fire and/or serious injury.

This appliance is not intended for use by persons (including children) with reduced physical, sensory or mental capabilities, or lack of experience and knowledge, unless they have been given supervision or instruction concerning the use of the appliance by a person responsible for their safety.

Children should be supervised to ensure that they do not play with the appliance.

If the power cord is damaged, it must be replaced by the manufacturer, service agent, or similarly qualified persons in order to avoid a hazard.

The appliance is only to be used with the power supply unit provided with the appliance.

Disconnect the power supply before cleaning and maintenance.

Instructions for appliances incorporating batteries that are intended to be replaced by the user shall include the following:

- Battery type: Rechargeable lithium-ion battery (A17B0)
- Disposal of a battery into a fire or hot oven, or mechanically crushing or cutting off a battery, can result in an explosion.
- **CAUTION:** Risk of explosion if the battery is replaced by an incorrect type. Do not use non-rechargeable batteries!
- A battery subjected to extremely low air pressure may cause an explosion or leakage of flammable liquid or gas. Under abusive conditions, liquid may be ejected from the battery—avoid contact. If contact accidentally occurs, rinse with water. If liquid gets in your eyes, seek medical help as it may cause irritation or burns.
- The battery must be removed from the appliance before it is scrapped.
- The appliance must be disconnected from the main power supply when removing the battery.
- Do not dispose of the battery in heat or fire. The battery is to be disposed of safely.
- When disposing of secondary cells or batteries, keep cells or batteries of different electrochemical systems separate from each other.

WARNING: For the purposes of recharging the battery, only use the detachable supply unit provided with this appliance.

When connecting to the DC power supply, the appliance must only be supplied at safety extra low voltage corresponding to the marking on the appliance.



Detachable Supply Unit GM95-145600-D

- Suitable for camping.

- The appliance shall not be exposed to rain.

Do not store explosive substances such as aerosol cans with a flammable propellant in this appliance.

WARNING: When positioning the appliance, ensure the power cord is not trapped or damaged.

WARNING: Do not place multiple portable socket outlets or portable power supplies at the rear of the appliance.

A child entrapment warning statement shall be included in either the operating instructions or in a use and care manual provided with each refrigerator and shall include the following or equivalent wording:

WARNING: Risk of child entrapment.

Before you throw away your old refrigerator or freezer:

- Remove the doors.
- Leave the shelves in place so children cannot easily climb inside.

Prevent unintentional starting. Ensure the switch is off before connecting to the battery pack, picking it up, or carrying the appliance. Carrying the appliance with your finger on the switch or powering the appliance with the switch on may lead to accidents.

Disconnect the battery pack from the appliance before making any adjustments, changing accessories, or storing the appliance. Such preventive safety measures reduce the risk of starting the appliance accidentally.

Recharge only with the charger specified by the manufacturer. A charger suitable for one type of battery pack may create a risk of fire when used with another battery pack.

Use appliances only with specifically designated battery packs. Use of any other battery packs may create a risk of injury and fire.

When the battery pack is not in use, keep it away from other metal objects, like paper clips, coins, keys, nails, screws, or other small metal objects, that can connect one terminal to another. Burn hazards or fire may occur if the terminals are shorted together.

Under abusive conditions, liquid may be ejected from the battery—avoid contact. If contact accidentally occurs, rinse with water. If liquid gets in your eyes, seek medical help.

Liquid ejected from the battery may cause irritation or burns.

Do not use a battery pack or appliance that is damaged or modified as they may exhibit unpredictable behavior resulting in fire explosion or risk of injury.

Do not expose a battery pack or appliance to fire or excessive temperature. Exposure to fire or temperature above 266°F (130°C) may cause an explosion.

Follow all charging instructions and do not charge the battery pack or appliance outside of the temperature range specified in the instructions. Charging improperly or at temperatures outside of the specified range may damage the battery and increase the risk of fire.

Have servicing performed by a qualified repair person using only identical replacement parts. This will ensure that the safety of the product is maintained.

Do not modify or attempt to repair the appliance or the battery pack except as indicated in the instructions for use and care.

The battery pack must be used with the Anker adapter (GM95-145600-D) for charging.

Do not expose the charger to rain, moisture, or snow.

To reduce the risk of damage to the cigarette lighter plug and cord, pull by plug rather than the cord when disconnecting the charger.

Make sure the cord is placed well so that it will not be stepped on, tripped over, or otherwise subjected to damage or stress.

Do not operate the charger with a damaged cord or cigarette lighter plug—replace it immediately.

Do not operate the charger if it has received a sharp blow, dropped, or otherwise damaged in any way.

Do not disassemble the charger. Take it to a qualified service person when service or repair is required. Incorrect reassembly may result in a risk of electric shock or fire.

To reduce the risk of electric shock, unplug the charger before attempting any maintenance or cleaning. Turning off controls will not reduce this risk.

Please be warned that the unit must be properly assembled in accordance with the assembly instructions before it is used.

Explain and describe the location, function, and operation of each unit control, including all user-operated devices intended to reduce the risk of fire, electric shock, or injury to persons. Please be warned against tampering with such devices.



This symbol indicates that this product shall not be treated as household waste. Instead, it shall be handed over to the applicable collection point for the recycling of electrical and electronic equipment.

FCC Statement

This device complies with Part 15 of the FCC Rules. Operation is subject to the following two conditions: (1) This device may not cause harmful interference, and (2) this device must accept any interference received, including interference that may cause undesired operation.

Warning: Changes or modifications not expressly approved by the party responsible for compliance could void the user's authority to operate the equipment.

Note: This equipment has been tested and found to comply with the limits for a Class B digital device, pursuant to Part 15 of the FCC Rules. These limits are designed to provide reasonable protection against harmful interference in a residential installation.

This equipment generates, uses, and can radiate radio frequency energy and, if not installed and used in accordance with the instructions, may cause harmful interference to radio communications. However, there is no guarantee that interference will not occur in a particular installation. If this equipment does cause harmful interference to radio or television reception, which can be determined by turning the equipment off and on, the user is encouraged to try to correct the interference by one or more of the following measures:

- (1) Reorient or relocate the receiving antenna.
- (2) Increase the separation between the equipment and receiver.

(3) Connect the equipment into an outlet on a circuit different from that to which the receiver is connected.

(4) Consult the dealer or an experienced radio / TV technician for help.

The following importer is the responsible party.

Company Name: Fantasia Trading LLC

Address: 5350 Ontario Mills Pkwy, Suite 100, Ontario, CA 91764

Telephone: +1-800-988-7973

RF Exposure Compliance Statement

This equipment complies with the FCC/IC radiation exposure limits set forth for an uncontrolled environment. This equipment should be installed and operated with a minimum distance of 0.03ft (20cm) between the radiator and your body.

Cet équipement est conforme aux limites d'exposition aux radiations FCC/IC établies pour un environnement non contrôlé. Cet équipement doit être installé et utilisé avec une distance minimale de 20 cm entre le radiateur et votre corps.

IC Statement

This device complies with Innovation, Science and Economic Development Canada's licence-exempt RSS(s). Operation is subject to the following two conditions: (1) This device may not cause interference, and (2) This device must accept any interference, including interference that may cause undesired operation of the device.

Le présent appareil est conforme aux CNR d'Industrie Canada applicables aux appareils radio exempts de licence. L'exploitation est autorisée aux deux conditions suivantes : (1) l'appareil ne doit pas produire de brouillage, et (2) l'utilisateur de l'appareil doit accepter tout brouillage radioélectrique subi, même si le brouillage est susceptible d'en compromettre le fonctionnement.

The device is in compliance with RF field strength limits, and users can obtain information on RF exposure and compliance.

Le présent appareil est conforme de ce matériel aux conformités ou aux limites d'intensité de champ RF, les utilisateurs peuvent sur l'exposition aux radiofréquences et la conformité d'acquérir les informations correspondante.

This Class B digital apparatus complies with the Canadian ICES-003.

Cet appareil numérique de la classe B est conforme à la norme NMB-003 du Canada.

CAN ICES-003 (B)/NMB-003(B)



Bluetooth:

The Bluetooth® word mark and logos are registered trademarks owned by the Bluetooth SIG, Inc. and any use of such marks by Anker Innovations Limited is under license. Other trademarks and trade names are those of their respective owners.

Manufacturer:

Anker Innovations Limited

Room 1318-19, Hollywood Plaza, 610 Nathan Road, Mongkok, Kowloon, Hong Kong

What's in the Box

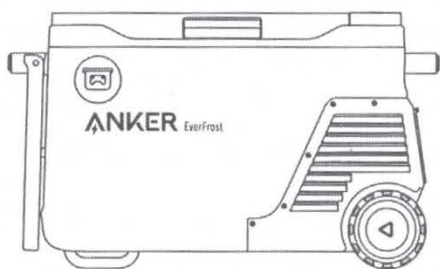

Anker EverFrost Powered Cooler 40

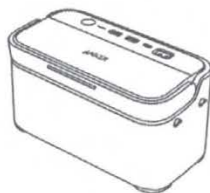

Anker Battery for Powered Cooler

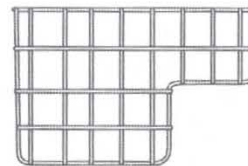

Storage Basket



Car Charging Cable

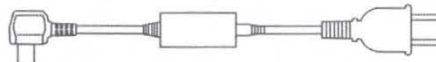

AC Adapter and Charging Cable



XT-60 Cable



User Manual

Overview

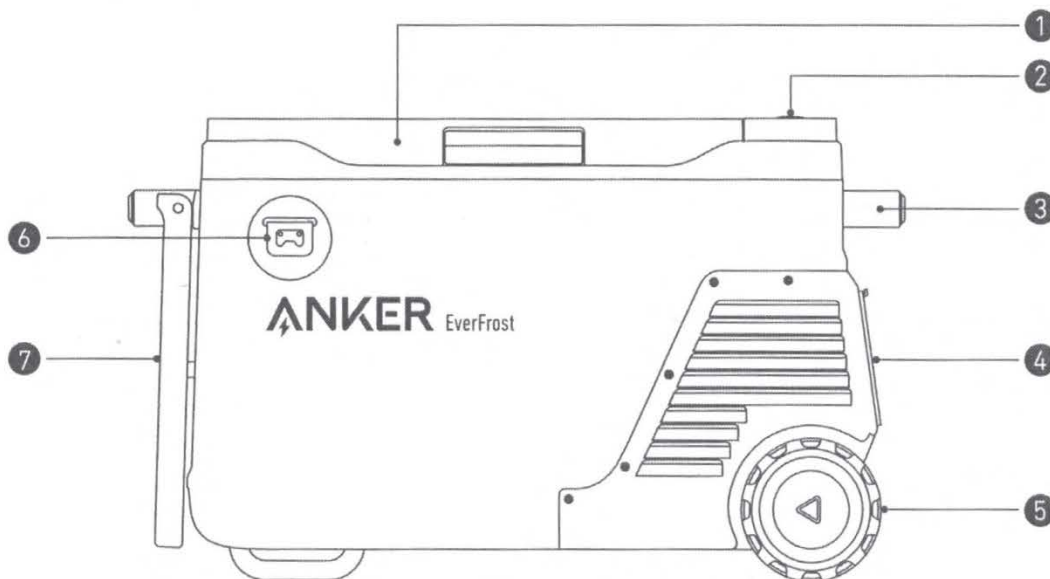

① Cooler Cover	⑤ Wheels
② LCD Screen	⑥ Bottle Opener
③ Handle	⑦ Tray Table
④ Battery Cover	

 Prop up the tray and set up the kickstand underneath the cooler.

LCD Screen

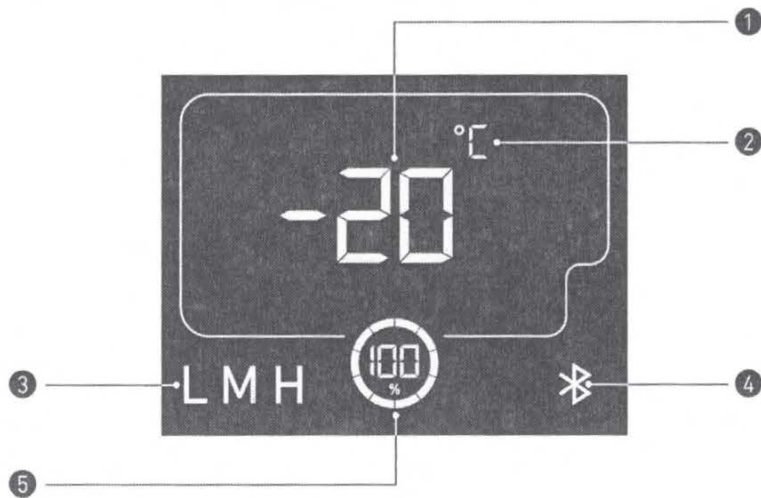

1 Temperature	4 Bluetooth
2 Temperature Unit	5 Remaining Battery in Percentage (if using battery to power)
3 Voltage Protection Level	

Powering Your Cooler

We do not recommend using multiple charging methods at the same time.

Without the Battery

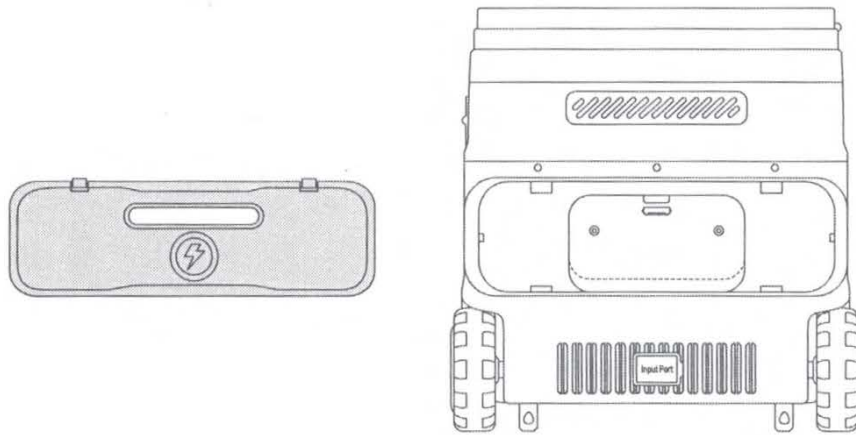

AC Power

Power the cooler by connecting to a wall outlet with the AC charging cable.

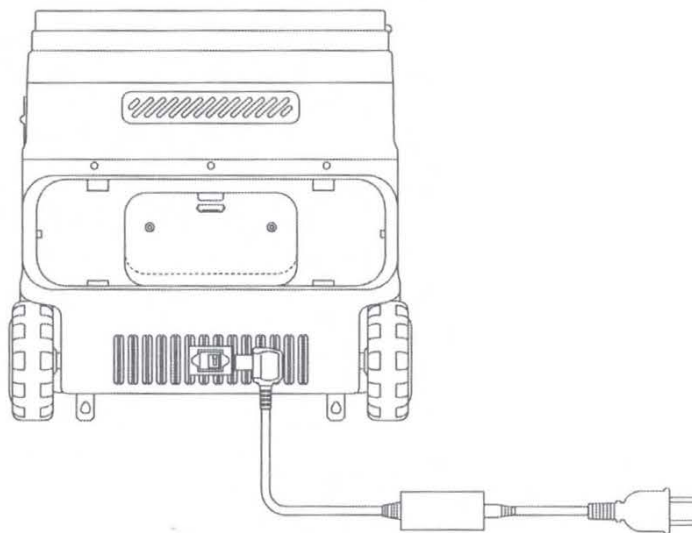

Power via Car

Connect the cooler to a car's output port with the car charging cable.

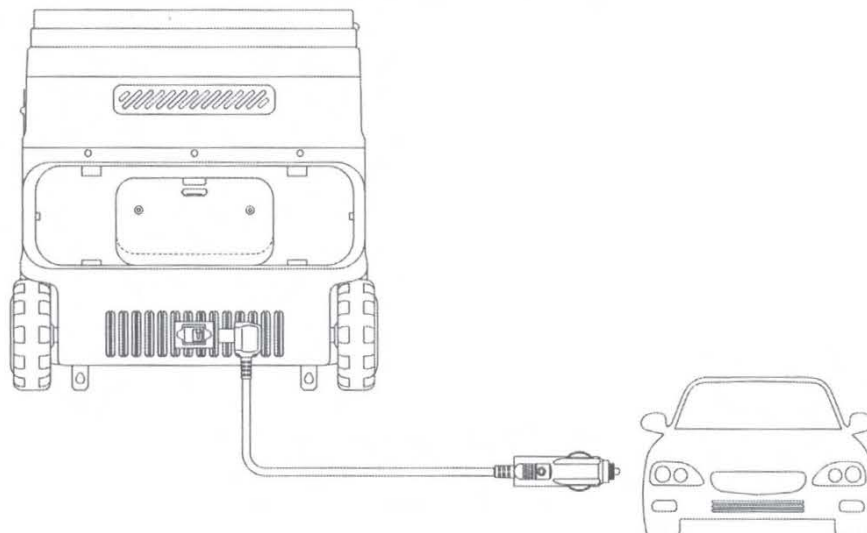

With the Battery

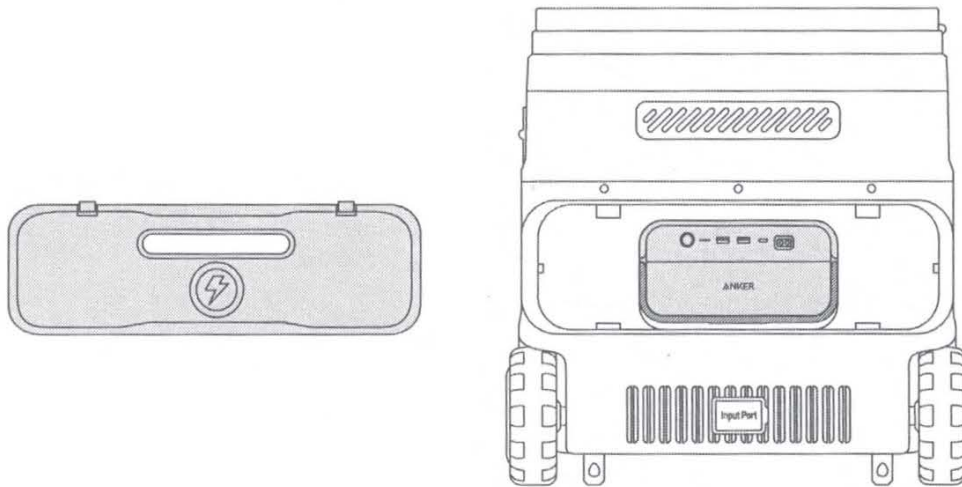

AC Power

Power the cooler by connecting to a wall outlet with the AC charging cable.

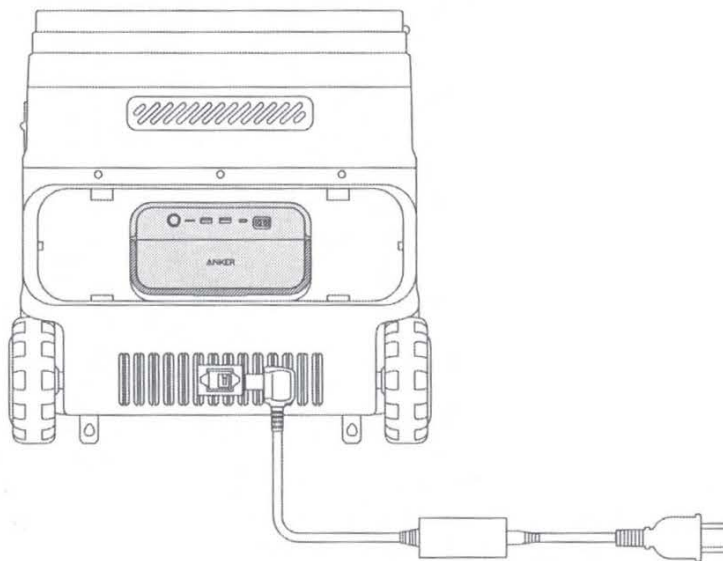

Power via Car

Connect the cooler to a car's output port with the car charging cable.

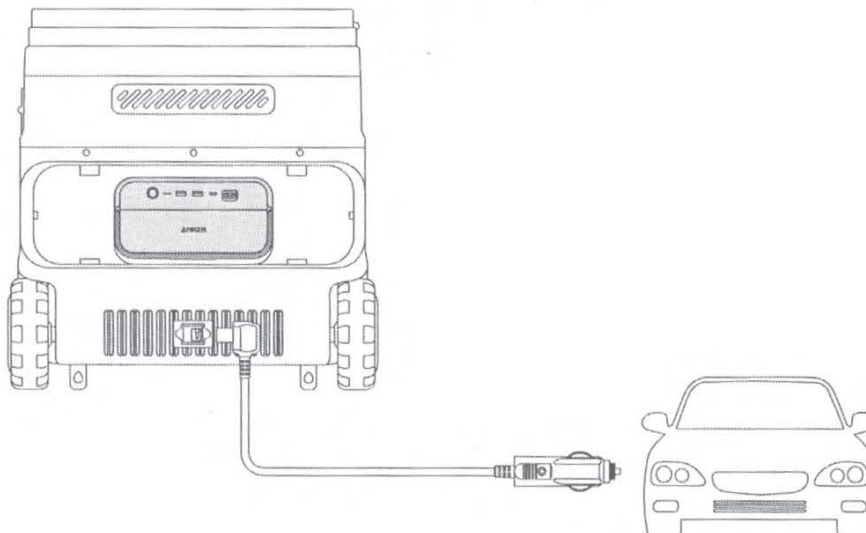

Recharging via Solar Panel

Power the cooler by connecting the battery to a solar panel with an XT-60 to XT-60 cable.

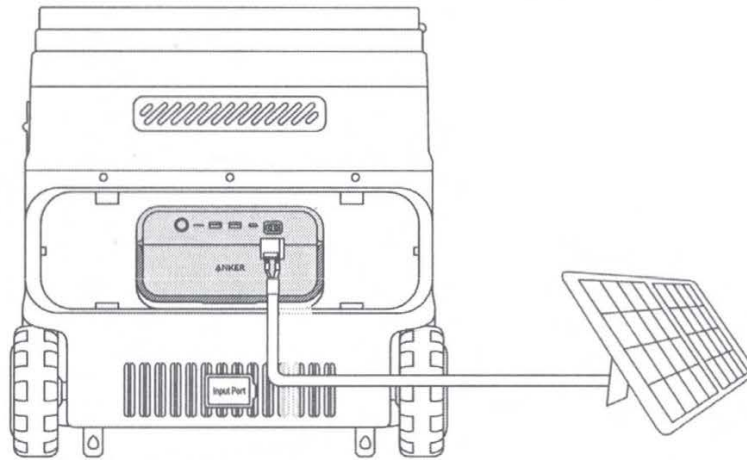

USB-C Recharging

Power the cooler by connecting the battery to a wall outlet with the USB-C cable.

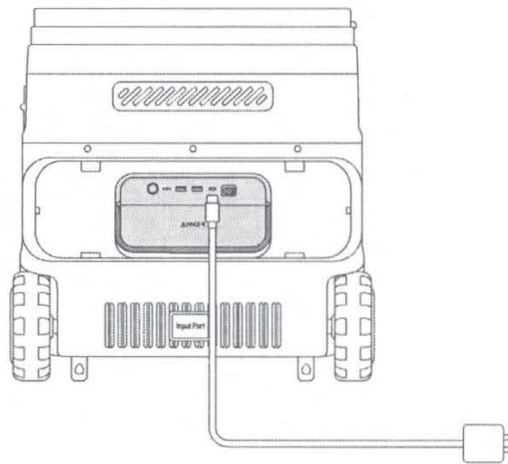

Using Your Cooler

1. Press the power button for two seconds to turn on your cooler. The LCD screen will light up.

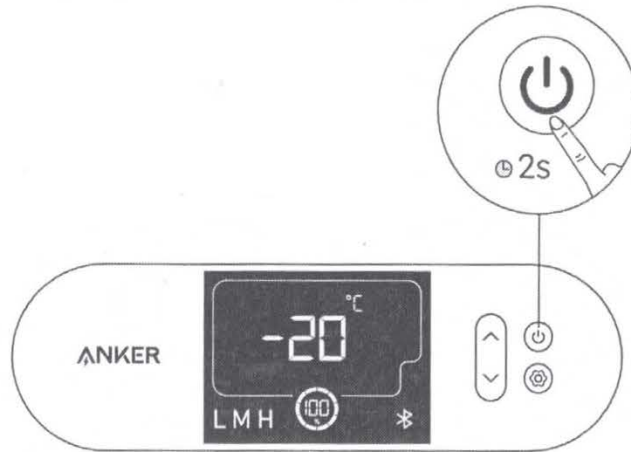

2. Push the cover up to open the cooler.

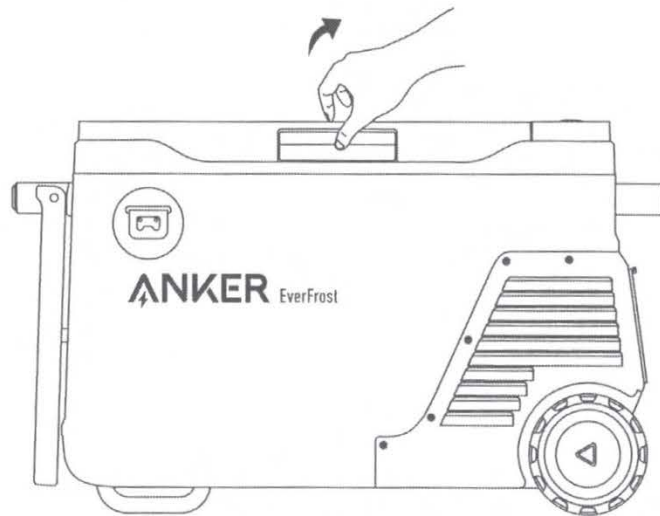

3. Press the power button once to light up the LCD screen.

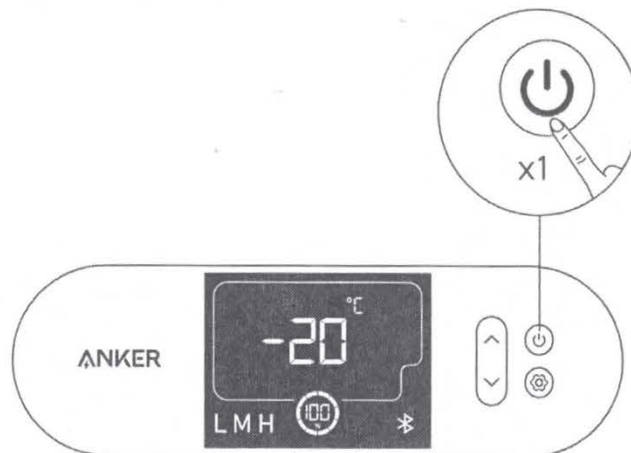

Installing the battery

Press the snap-fits to remove the battery cover. Place the battery inside and you will hear a click when the installation is successful. Then, place the battery cover back.

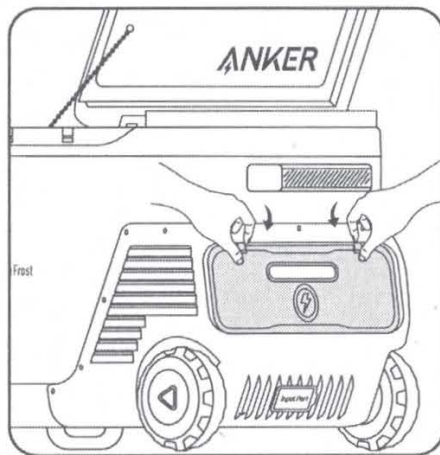

1

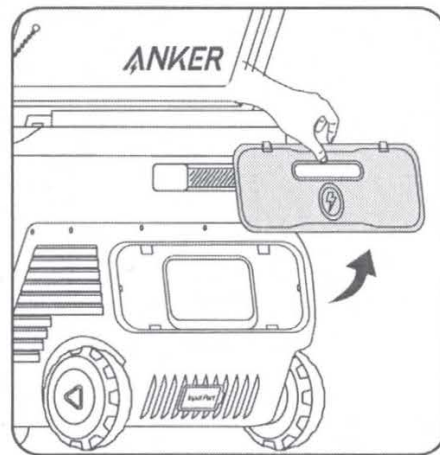

2

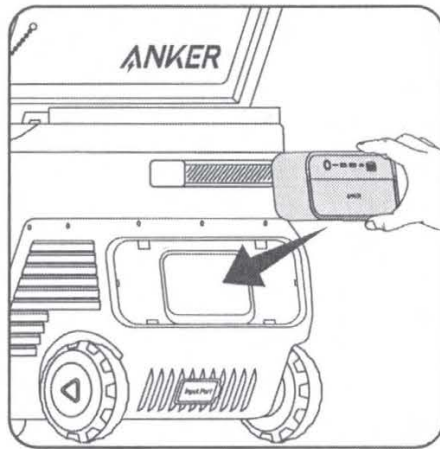

3

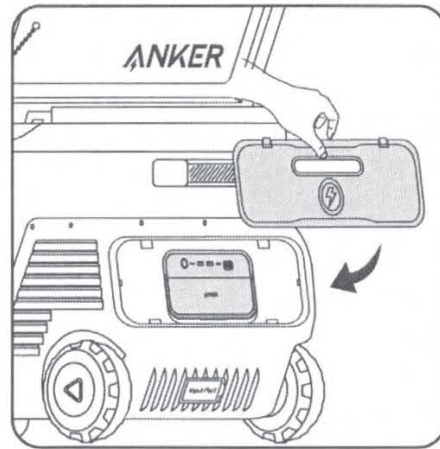

4

 The battery cover will automatically open when lifted up.

Setting the Temperature

To enter the temperature adjustment mode, press the settings button until the temperature number flashes. Press the up or down buttons to adjust the zone temperature, and confirm your temperature by pressing the settings button again.

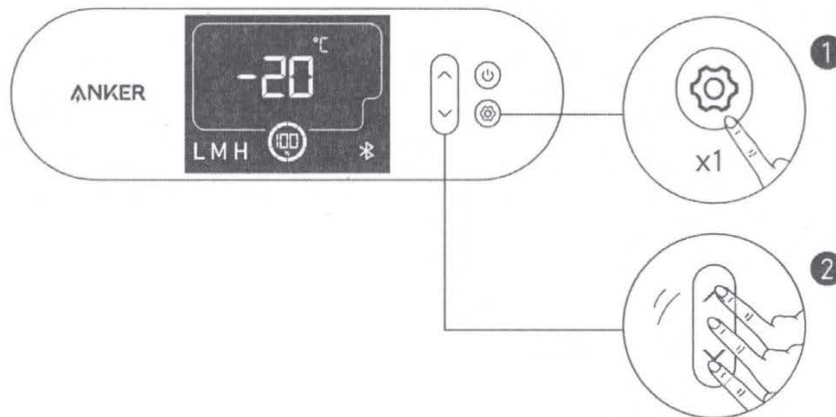

Setting the Temperature Unit

To enter the temperature adjustment mode, press the settings button until the temperature unit icon flashes. Press the up or down buttons to choose between "Celsius/Fahrenheit," and confirm the unit by pressing the settings button again.

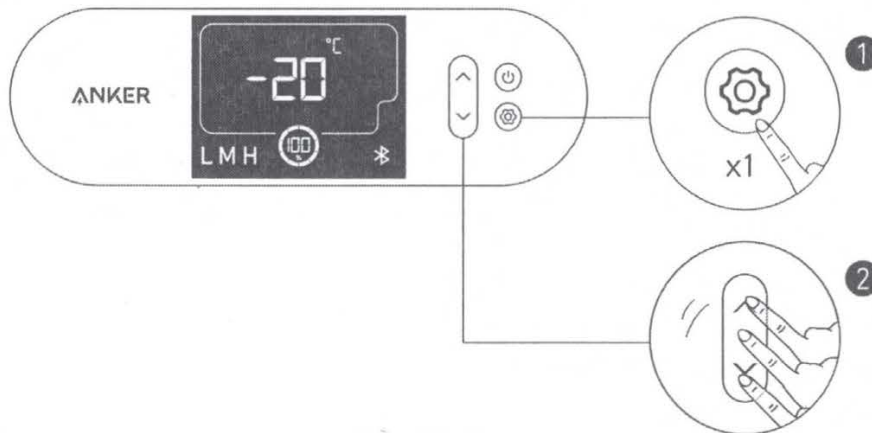

Bluetooth

Press the settings button for 2 seconds to turn on Bluetooth. The Bluetooth icon on the screen will flash. It will automatically connect to your phone with Bluetooth on, and the icon will turn steady white.

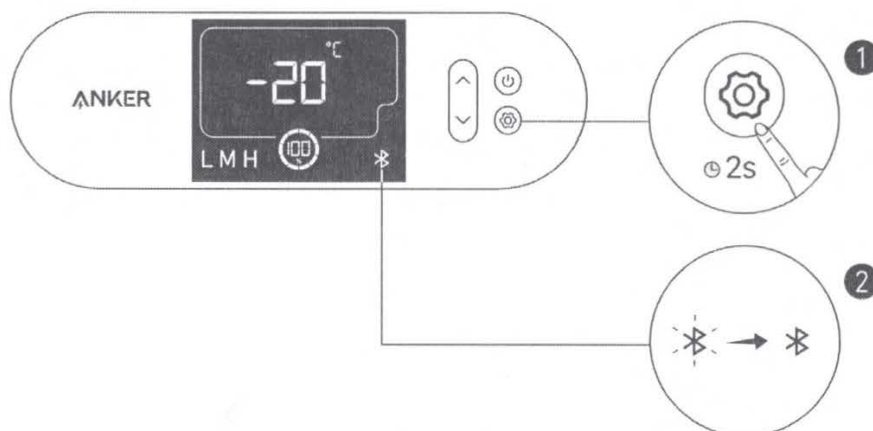

The Bluetooth function will be turned off after 12 hours without any connection.

Car Battery Protection Grades

To enter the voltage level adjustment mode, press the settings button until the voltage level icon flashes. Press the up or down buttons to choose between "L/M/H", and confirm it by pressing the settings button again. Select "M/H" gear when the product is powered via a car. It's recommended to select "L" gear when powered by an independent power supply.

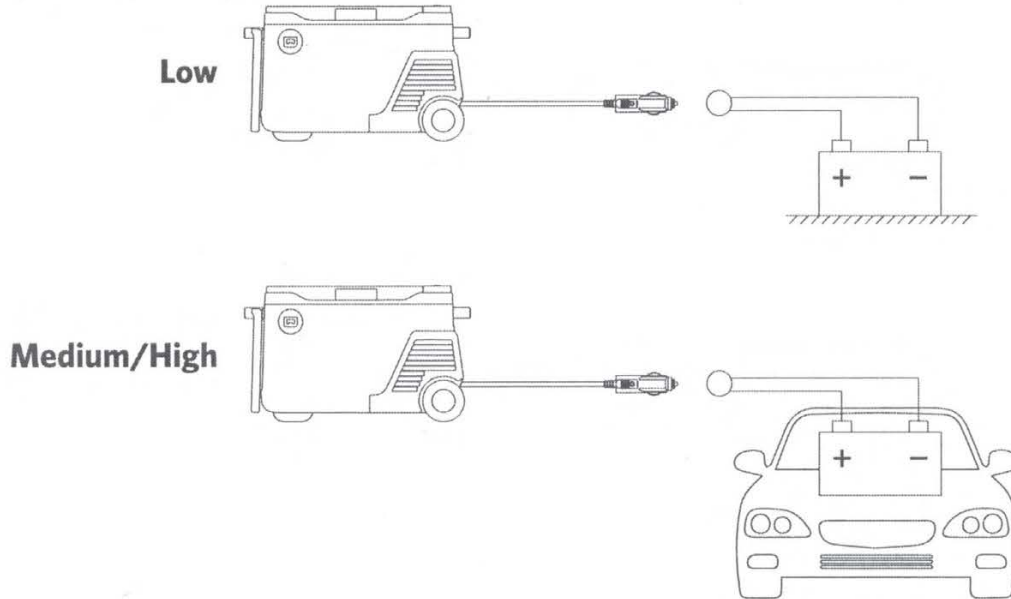

	Operating voltage	Start-up voltage	Operating voltage	Start-up voltage
High	12 V	12.5 V	24.7 V	26.1 V
Medium	11.4 V	12.2 V	24.3 V	25.3 V
Low	10.4 V	11.3 V	21.9 V	22.9 V

When the car's battery voltage is lower than the set value without the battery, your cooler will stop working. When the car's battery voltage is lower than the set value, the cooler switches to its own battery for power supply. Once the car battery is restored, it switches to the car battery's power source.

The Anker App for Smart Control

You can remotely control your powered cooler using the Anker app. Please download the app and its user manual by scanning this QR code.

Connect the device to a network before using the app for the first time. After connecting successfully, you can connect your devices off-grid.



Specifications

Storage Capacity	43L
Battery Capacity	299.52Wh
AC Input Voltage	100V-240V, 50Hz/60Hz
AC Input Power	95W Max
DC Input	5.5A(12V)/ 2.5A(24V)
Refrigerant	R134a(34g)
Size	73.2 x 43.0 x 48.7cm
Net Weight	21.8kg/48lb
Temperature Range In the Fridge	-20 ~ 20° C/-4~68° F
Operating Temperature Range	0 - 40°C / 32 ~ 104° F

Troubleshooting

- **Reminder to Close Doors:** The buzzer will send a reminder if the cooler's cover is not closed for more than 180 seconds.
- The cooler will stop working if the tilt angle exceeds 30 degrees. Place it horizontally, and it will resume normal operation in 5 minutes.

FAQ

Q1: How long does the cooler's battery last when fully charged?

The battery capacity of the cooler is 299.52Wh. When the cooler's temperature is at 25°C (77° F) ambient temperature, it will run for 35.8 hours with 4°C (39.2° F) storage temperature.

Q2: What ambient temperature can the cooler be used normally?

The recommended ambient temperature is 32°F - 104°F (0 - 40°C).

Q3: What should I do when using a solar charger to charge Anker EverFrost Powered Cooler?

The solar input supports an 11-30V solar charger with an XT-60 connector. We recommend using Anker 100W Solar Panel to get the best compatibility.

Anker EverFrost Powered Cooler Warranty Policy

This Anker EverFrost Powered Cooler purchased on AnkerDirect and Anker authorized resellers to come with a limited warranty ("warranty") as set out below. By using an Anker EverFrost Powered Cooler, you agree to be bound by the terms of the Anker limited warranty.

2-year limited warranty for Anker EverFrost Powered Cooler and 3-year limited warranty for the compressor for purchases made on AnkerDirect and Anker authorized resellers. The warranty period starts from the date of purchase.

Anker's limited warranty is restricted to the country of purchase. The limited warranty is void on items taken outside the country they were originally bought in or shipped to directly from an authorized online purchase.

Exclusions and Limitations

Not covered under warranty:

- Products that are damaged or modified.
- Products operated with a damaged cord, plug, or output cable.
- Products that are disassembled.
- Products that are cleaned with harmful chemicals or detergents.
- Non-quality related issues (after 30 days of purchase).
- Products purchased from unauthorized resellers.
- Products without sufficient proof of purchase.
- Products that have been refunded.
- Products with an expired warranty.
- Lost, stolen, or free products.
- Damage from outside sources.
- Repairs through 3rd parties.
- Damage from misuse of products (including, but not limited to falls, use of the product in excess of its output rating, exposure of the product to rain or snow, extremely low air pressure, extreme temperatures).
- Purchases from illegitimate sources.
- Batteries that are damaged when not used for a long time or not properly maintained according to the user manual.

Anker is Not Liable For:

- Loss of data incurred from the use of Anker products.
- Returning personal items sent to Anker.

When returning items with a prepaid shipping label provided by Anker, Anker takes responsibility for any damage or loss incurred in transit. When returning items for non-quality issues, the buyer assumes responsibility for any damage or loss incurred in transit. Anker does not provide refunds for items damaged in transit due to non-quality related warranty claims.

Refund and Warranty Claims

For more details please refer to www.anker.com/anker-portable-power-station-warranty-policy

For warranty claims, you can send an email to:

US/CA/UK/DE/JP market: support@anker.com

MEA market: support.mea@anker.com

CN market: CED-CN@anker.com

Or you can call us at:

US/CA: +1 (800) 988 7973 UK: +44(0)1604 936 200

DE: +49(0)69 9579 7960 JP: +81 03 4455 7823

UAE: +971 8000 320 817 KSA: +966 8008 500 030

Kuwait: +965 2206 9086 Egypt: +20 8000 000 826

AU: +61 3 8331 4800 TR: +90(850)460 1414

RU: +8(800)511 8623 CN: +86 400 0550 036

KR: +82 0216 7070 98 IN: +91 1800 3138 831

Middle East & Africa: +971 4242 8633

Valid Proof of Purchase

Please refer to: <https://us.anker.com/policies/refund-policy>

Shipping Costs Must Be Covered by the Buyer in the Following Situations

Please refer to: <https://us.anker.com/policies/refund-policy>

This page is attached to the Anker warranty page, and Anker reserves the right of final interpretation of the content.

Register Your Anker PowerHouse Today

Why Register?

1. Hassle-Free Warranty: Confirm the 2-year limited warranty for your Anker EverFrost Powered Cooler and 3-year limited warranty for the compressor.
2. Fast Customer Service: Enjoy exclusive customer service and get what you need quickly.
3. Receive the Latest News: Get exclusive first looks at new products and instant updates on official events.



- Scan the QR code below to enter the smart self-service page for more information about your Anker EverFrost.



Customer service



2-Year Limited Warranty*

* Please note that your rights under applicable law governing the sale of consumer goods remain unaffected by the warranties given in this Limited Warranty.



Lifetime technical support



support@anker.com

support.mea@anker.com (For Middle East and Africa Only)



(US/CA) +1 (800)988 7973

(DE) +49 (0) 69 9579 7960

(UAE) +971 8000320817

(Kuwait) +965 22069086

(AU) +61 3 8331 4800

(RU) +8 (800) 511-86-23

(日本) 03 4455 7823

(India) +91 18003138831

(UK) +44 (0) 1604 936200

(Middle East & Africa) +971 42428633

(KSA) +966 8008500030

(Egypt) +20 8000000826

(TR) +90 0850 460 14 14

(中国) +86 400 0550 036

(한국) +82 02-1670-7098

For tutorial videos, FAQs, manuals, and more information, please visit:

<https://support.anker.com>

Or scan the QR code below:

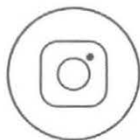

@anker_official
@anker_jp



@AnkerDeutschland
@AnkerJapan
@Anker

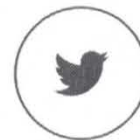

@AnkerOfficial
@Anker_JP

ANKER

Live Charged.



**Anker Detachable Battery For Powered Cooler
(299Wh)**

USER MANUAL

Overview

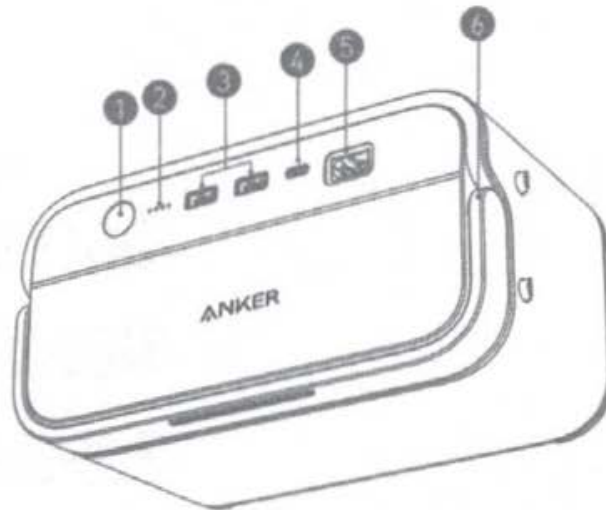

- | | |
|---|-----------------------|
| 1. Power Button | 4. USB-C Output/Input |
| 2. LED Lights (Indicates Remaining Battery) | 5. XT-60 Input |
| 3. USB-A Output | 6. Handle |

Using the Battery

Press the power button to turn on the LED lights.

The LED lights indicate the remaining battery level.

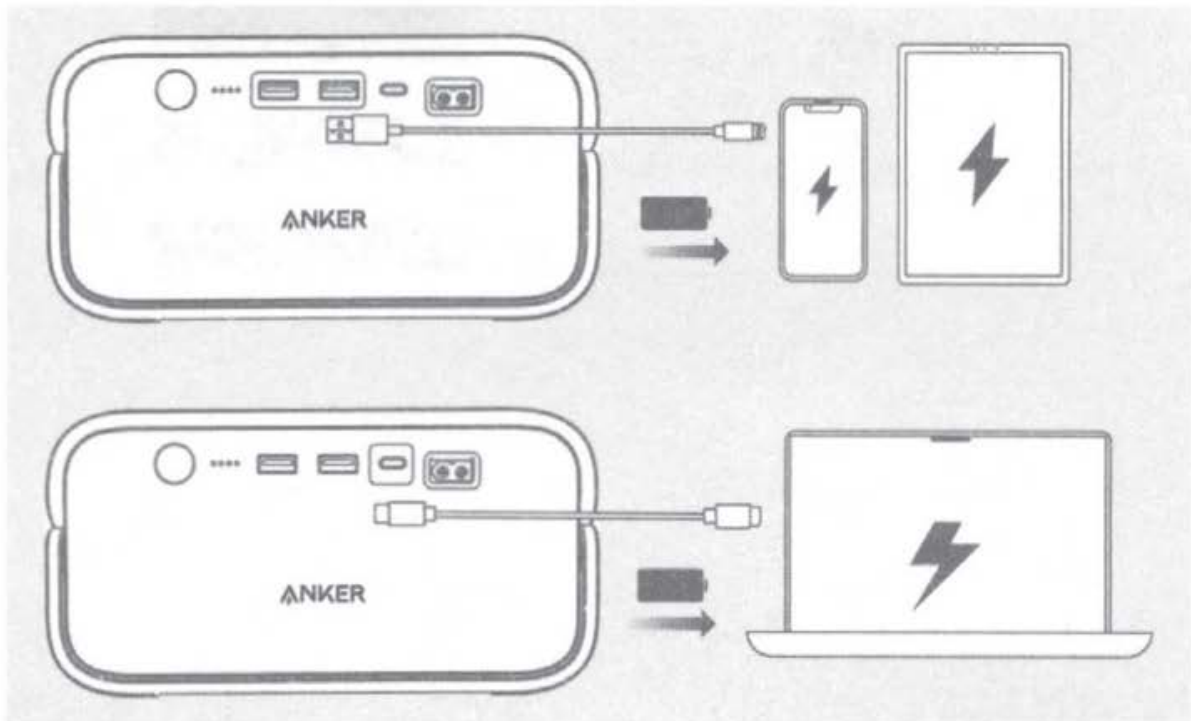

Charging the Battery

AC Power

Charge the battery by connecting it to the AC adapter and XT-60 charging cable.

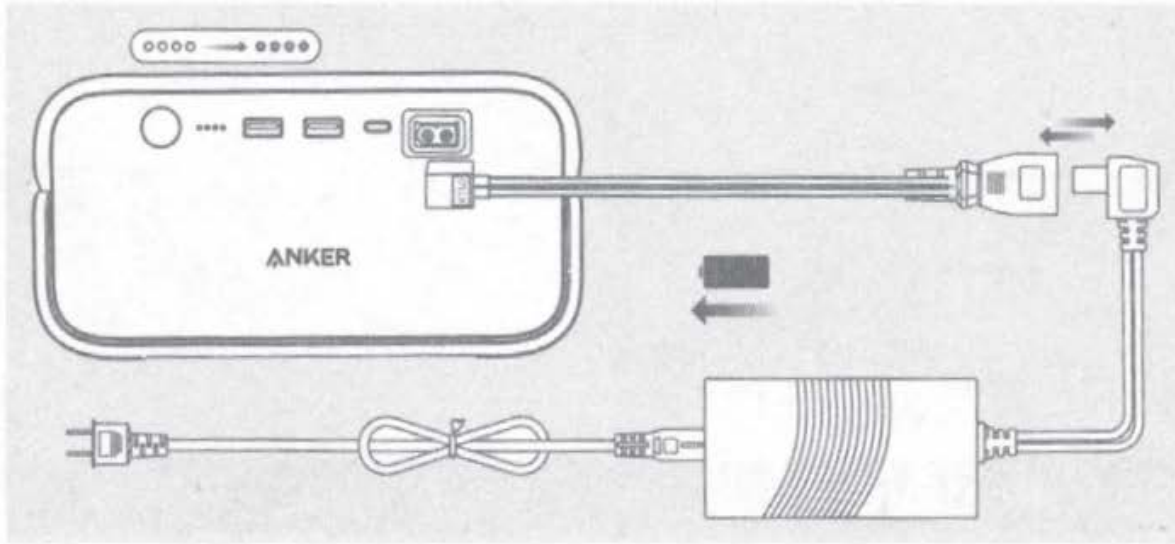

PD Power

Charge the battery by connecting it to a wall outlet with the USB-C cable.

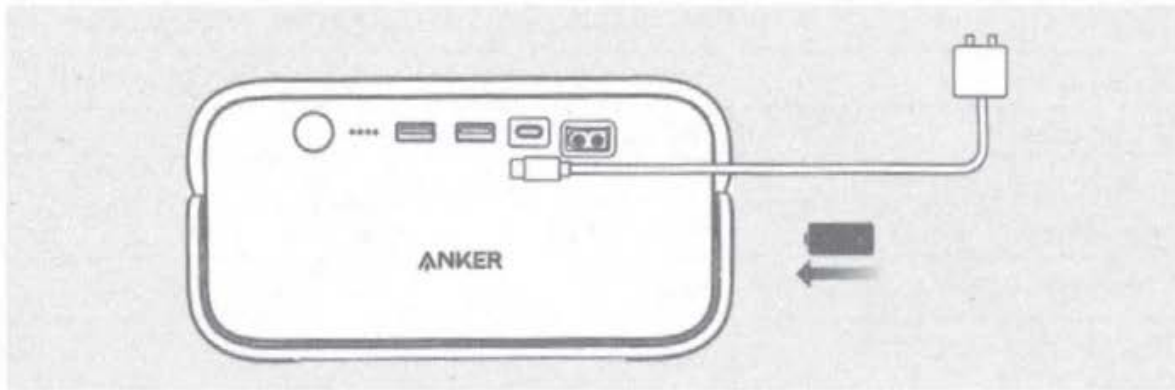

Power via Solar

Charge the battery by connecting it to a solar panel with an XT-60 to XT-60 cable.

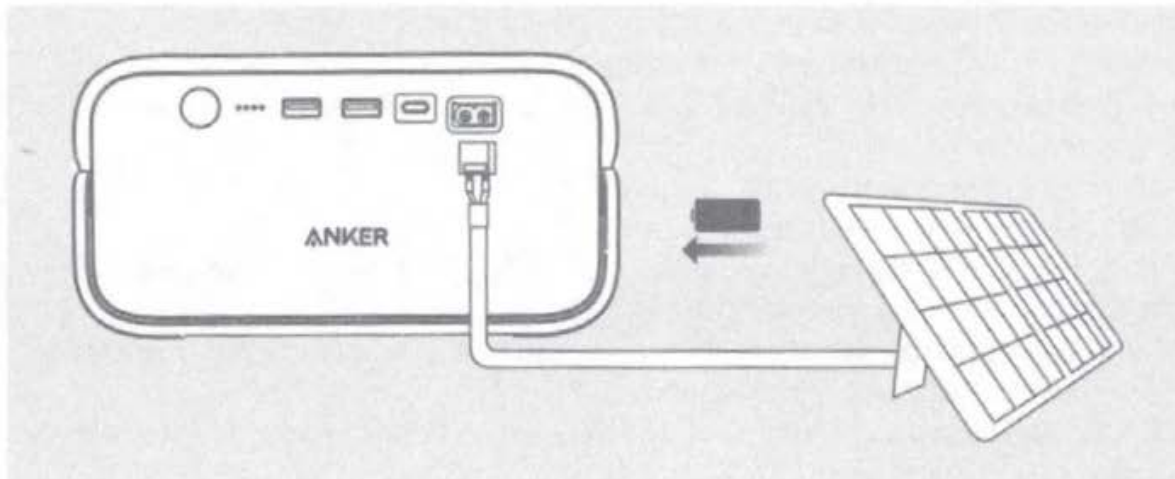

Power via Car

Charge the battery by connecting it to the car charging cable with an XT-60 cable.

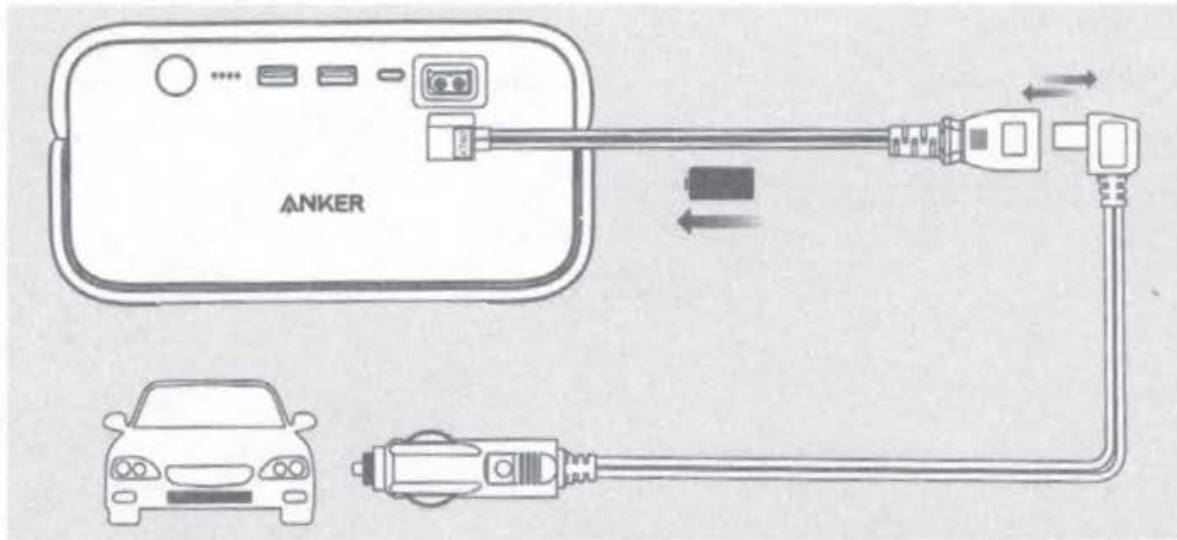

Specifications

Cell Capacity	299Wh
USB-A Output	5V = 2.4A (2.4A Max Per Port)
Type-C Output	5V = 3A/ 9V = 3A/ 15V = 3A/20V = 3A (60W Max)
USB-C Input	5V = 3A/ 9V = 3A/ 15V = 3A/20V = 3A (60W Max)
DC Input	11-28V = 10A (100W Max)
Size	19.9*10.2*10.8 cm
Net Weight	4.85lb / 2.2kg
Charging Temperature Range	0-40°C
Discharging Temperature Range	-20-40°C

Important Safety Instructions

When using this product, basic precautions should always be followed:

- Read all the instructions before using the product.
- To reduce the risk of injury, close supervision is necessary when the product is used near children.
- Do not put fingers or hands into the product.
- Do not expose the product to rain or snow.
- Use of an attachment not recommended or sold by the product manufacturer may result in a risk of fire, electric shock, or injury.
- To reduce the risk of damage to the electric plug and cord, pull the plug instead of the cord when disconnecting the product.
- Do not use the product in excess of its output rating. Overload outputs above the rating may result in a risk of fire or injury.

- Do not use a product that is damaged or modified. It may exhibit unpredictable behavior resulting in fire, explosion, or risk of injury.
- Do not operate the product with a damaged cord, plug, or output cable.
- Do not disassemble the product. Take it to a qualified service person when service or repair is required. Incorrect reassembly may result in a risk of fire or electric shock.
- Do not expose the product to fire or high temperatures. Exposure to fire or temperatures above 266°F (130°C) may cause explosions.
- To reduce the risk of electric shock, unplug the power pack from the outlet before attempting any instructed servicing.
- Have servicing performed by a qualified repair person using only identical replacement parts. This will ensure that the safety of the product is maintained.
- When charging a device, the product may feel warm. This is a normal operating condition and should not be a cause for concern.
- When charging the internal battery, work in a well-ventilated area and do not restrict ventilation.
- Do not clean the product with harmful chemicals or detergents.
- Misuse, dropping, or excessive force may cause product damage.
- When disposing of secondary cells or batteries, keep cells or batteries of different electrochemical systems separate.
- Do not use or store the battery in direct sunlight for a long period, such as in a car, cargo bed, or any other place where it will be exposed to high temperatures. Doing so may cause the product to malfunction, deteriorate, or generate heat.

CAUTION: Risk of explosion if the battery is replaced by an incorrect type.

- Disposal of the battery into a fire or hot oven, or mechanically crushing or cutting off a battery, can result in an explosion.
- Leaving the battery in an extremely high-temperature environment can result in an explosion or leakage of flammable liquid or gas.
- A battery subjected to extremely low air pressure may cause an explosion or leakage of flammable liquid or gas.

Declaration of Conformity

Hereby, Anker Innovations Limited declares that this product is in compliance with Directives 2014/35/EU, 2014/30/EU & 2011/65/EU. The full text of the EU declaration of conformity is available at the following internet address:
<https://www.anker.com>

GB Declaration of Conformity

Hereby, Anker Innovations Limited declares that the product, A17B0, is in compliance with the Electrical Electromagnetic Compatibility Regulations 2016 & The Restriction of the Use of Certain Hazardous Substances in Electrical and Electronic Equipment Regulations 2012. The full text of the GB declaration of conformity is available at the following internet address:
<https://www.anker.com>

Anker Innovations Limited | Room 1318-19, Hollywood Plaza, 610 Nathan Road, Mongkok, Kowloon, HongKong

The following importer is the responsible party (contract for EU and UK matters)

Anker Innovations Deutschland GmbH | Georg-Muche-Strasse 3, 80807 Munich, Germany
Anker Technology (UK) Limited | GNR8, 49 Clarendon Road, Watford, Hertfordshire,
WD17 1HP, United Kingdom

FCC Statement

This device complies with Part 15 of the FCC Rules. Operation is subject to the following two conditions: (1) This device may not cause harmful interference, and (2) this device must accept any interference received, including interference that may cause undesired operation.

Warning: Changes or modifications not expressly approved by the party responsible for compliance could void the user's authority to operate the equipment.

Note: This equipment has been tested and found to comply with the limits for a Class B digital device, pursuant to Part 15 of the FCC Rules. These limits are designed to provide reasonable protection against harmful interference in a residential installation.

This equipment generates, uses, and can radiate radio frequency energy and, if not installed and used in accordance with the instructions, may cause harmful interference to radio communications. However, there is no guarantee that interference will not occur in a particular installation. If this equipment does cause harmful interference to radio or television reception, which can be determined by turning the equipment off and on, the user is encouraged to try to correct the interference by one or more of the following measures:

- (1) Reorient or relocate the receiving antenna.
- (2) Increase the separation between the equipment and receiver.
- (3) Connect the equipment to an outlet on a circuit different from that to which the receiver is connected.
- (4) Consult the dealer or an experienced radio/TV technician for help.

The following importer is the responsible party.

Company Name: Fantasia Trading LLC

Address: 5350 Ontario Mills Pkwy, Suite 100, Ontario, CA 91764

Telephone: +1-800-988-7973

IC Statement

This device complies with Industry Canada license-ICES-003. Operation is subject to the following two conditions: (1) This device may not cause interference, and (2) This device must accept any interference, including interference that may cause undesired operation of the device.

Le présent appareil est conforme aux CNR d'Industrie Canada applicables aux appareils radio exempts de licence. L'exploitation est autorisée aux deux conditions suivantes : (1) l'appareil ne doit pas produire de brouillage, et (2) l'utilisateur de l'appareil doit accepter tout brouillage radioélectrique subi, même si le brouillage est susceptible d'en compromettre le fonctionnement.

IC Statement:

This digital apparatus complies with CAN ICES-003(B) / NMB-003(B).

Anker Detachable Battery For Powered Cooler (299Wh) Warranty Policy

This Anker Detachable Battery For Powered Cooler (299Wh) purchased on AnkerDirect and Anker authorized resellers comes with a limited warranty ("warranty") as set out below. By using an Anker Detachable Battery For Powered Cooler (299Wh), you agree to be bound by the terms of the Anker limited warranty.

2-year limited warranty of the Anker Detachable Battery For Powered Cooler (299Wh) for purchases made on AnkerDirect and Anker authorized resellers. The warranty period starts from the date of purchase.

Anker's limited warranty is restricted to the country of purchase. The limited warranty is void on items taken outside the country they were originally bought in or shipped to directly from an authorized online purchase.

Exclusions and Limitations

Not covered under warranty:

- Products that are damaged or modified.
- Products operated with a damaged cord, plug, or output cable.
- Products that are disassembled.
- Products that are cleaned with harmful chemicals or detergents.
- Non-quality related issues (after 30 days of purchase).
- Products purchased from unauthorized resellers.
- Products without sufficient proof of purchase.
- Products that have been refunded.
- Products with an expired warranty.
- Lost, stolen, or free products.
- Damage from outside sources.
- Repairs through 3rd parties.
- Damage from misuse of products (including, but not limited to falls, use of the product in excess of its output rating, exposure of the product to rain or snow, extremely low air pressure, and extreme temperatures).
- Purchases from illegitimate sources.
- Batteries that are damaged when not used for a long time or not properly maintained according to the user manual.

Anker Detachable Battery For Powered Cooler (299Wh) Warranty Policy

- Loss of data incurred from the use of Anker products.
- Returning personal items sent to Anker.

When returning items with a prepaid shipping label provided by Anker, Anker takes responsibility for any damage or loss incurred in transit. When returning items for non-quality issues, the buyer assumes responsibility for any damage or loss incurred in transit. Anker does not provide refunds for items damaged in transit due to non-quality related warranty claims.

Refund and Warranty Claims

For more details, please refer to www.anker.com/anker-portable-power-station-warranty-policy

For warranty claims, you can send an email to:

US/CA/UK/DE/JP market: support@anker.com

MEA market: support.mea@anker.com
CN market: CED-CN@anker.com

Or you can call us at:

US/CA: +1 (800)988 7973	UK: +44(0)1604 936 200	DE: +49(0)69 9579 7960
JP: +81 03 4455 7823	UAE: +971 8000 320 817	KSA: +966 8008 500 030
Kuwait: +965 2206 9086	Egypt: +20 8000 000 826	AU: +61 3 8331 4800
TR: +90(850)460 1414	RU: +8(800)511 8623	CN: +86 400 0550 036
KR: +82 0216 7070 98	IN: +91 1800 3138 831	
Middle East & Africa: +971 4242 8633		

Valid Proof of Purchase

Please refer to: <https://us.anker.com/policies/refund-policy>.

Shipping Costs Must Be Covered by the Buyer in the Following Situations

Please refer to: <https://us.anker.com/policies/refund-policy>.

This page is attached to the Anker warranty page, and Anker reserves the right of final interpretation of the content.

Register Your Anker Detachable Battery For Powered Cooler (299Wh) Today

Why Register?

- 1. Hassle-Free Warranty:** Confirm the 2-year warranty for your Anker Detachable Battery For Powered Cooler (299Wh).
- 2. Fast Customer Service:** Enjoy exclusive customer service and get what you need quickly.
- 3. Receive the Latest News:** Get exclusive first looks at new products and instant updates on official events.



Scan the QR code below to enter the smart self-service page for more information about your Anker Detachable Battery For Powered Cooler (299Wh).



Customer Service

DE: Kundenservice ES: Atención al Cliente FR: Service Client
IT: Servizio Clienti NL: Klantenservice PT: Serviço de Apoio ao Client
JP: カスタマーサポート

HE: ירות לקוחות AR: خدمة العملاء



EN: 2-Year Limited Warranty*
DE: 2 Jahre eingeschränkte Garantie*
ES: Garantía limitada de 2 años*
FR: Garantie limitée de 2 ans*
IT: Garanzia limitata di 2 anni*
NL: Twee jaar beperkte garantie
PT: 2 anos de garantia limitada
JP: 最大2年保証(通常18ヶ月、Anker Japan 公式サイト会員登録で2年に延長)

AR: ضمان محدود لمدة 2 تاونس
HE: אחריות מוגבלת לשנתיים



EN: Lifetime technical support
DE: Technischer Support für die Produktlebensdauer
ES: Asistencia técnica de por vida
FR: Support technique à vie
IT: Assistenza post-vendita a vita
NL: Levenslange technische ondersteuning
PT: Suporte técnico ao longo da vida útil do produto
JP: テクニカルサポート

AR: الدعم الفني مدى الحياة
HE: תמיכה טכנית לכל החיים



support@anker.com

support.mea@anker.com (For Middle East and Africa Only)



(US/CA) +1 (800)988 7973 (UK) +44 (0) 1604 936200 (DE) +49 (0) 69 9579 7960
(UAE) +971 8000320817 (KSA) +966 8008500030 (Kuwait) +965 22069086
(Egypt) +20 8000000826 (AU) +61 3 8331 4800 (TR) +90 0850 460 14 14
(RU) +8 (800) 511-86-23 (中国) +86 400 0550 036 (日本) 03 4455 7823
(한국) +82 02-1670-7098 (India) +91 1800313883 1
(Middle East & Africa) +971 41828633

- * **EN:** Please note that your rights under applicable law governing the sale of consumer goods remain unaffected by the warranties given in this Limited Warranty.
DE: Die gesetzlichen Gewährleistungspflichten bleiben von der beschränkten Herstellergarantie unberührt.
ES: Tenga en cuenta que los derechos que le conceden las leyes aplicables que rigen la venta de bienes de consumo no se ven afectados por las garantías que proporciona esta garantía limitada.
FR: Notez que vos droits dans le cadre de la législation régissant la vente de biens de consommation ne sont pas affectés par les garanties accordées dans cette garantie limitée.
IT: Si prega di notare che i diritti del cliente ai sensi della legge applicabile in materia di vendita di beni di consumo non sono influenzati dalle garanzie concesse dalla presente Garanzia limitata.

For FAQs and more information, please visit:

anker.com/support



@anker_official
@anker_jp



@AnkerDeutschland
@Anker Japan
@Anker



@AnkerOfficial
@Anker_JP

For tutorial videos, FAQs, manuals, and more information,
please visit: <https://support.anker.com>
Or scan the QR code below:



PAP 22
Raccolta Carta

Product Number: A1780 51005003840 V01