

RF MEASUREMENT REPORT

FCC ID: 2AXJ4XE75V2
Applicant: TP-Link Corporation Limited
Product: AXE5400 Whole Home Mesh Wi-Fi 6E System
Model No.: Deco XE75, Deco XE5300, Deco XE75 Pro
Brand Name: tp-link
FCC Classification: Unlicensed National Information Infrastructure (NII)
FCC Rule Part(s): Part 15 Subpart E (Section 15.407)
Result: Complies
Received Date: 2022-11-30
Test Date: 2022-12-02 ~ 2022-12-20

Reviewed By:

Kevin Guo

Approved By:

Robin Wu



The test results relate only to the samples tested.

This equipment has been shown to be capable of compliance with the applicable technical standards as indicated in the measurement report and was tested in accordance with the measurement procedures specified in KDB789033. Test results reported herein relate only to the item(s) tested.

The test report shall not be reproduced except in full without the written approval of MRT Technology (Shenzhen) Co., Ltd.

Revision History

Report No.	Version	Description	Issue Date	Note
2211RSU084-U2	V01	Initial Report	2023-02-06	Valid

Note: This report is prepared for FCC Class II permissive change supplement based on the FCC ID: 2AXJ4XE75V2, original grant date: December 28, 2022, the changes and verified item refer to the section 2.1 of this report.

CONTENTS

Description	Page
1. General Information	5
1.1. Applicant	5
1.2. Manufacturer.....	5
1.3. Testing Facility	5
1.4. Product Information	6
1.5. Radio Specification under Test.....	6
1.6. Working Frequencies.....	7
1.7. Antenna Details	7
2. Test Configuration	8
2.1. Test Details for Class II Perssive Change	8
2.2. Test Mode	8
2.3. Test System Connection Diagram	9
2.4. Test System Details	9
2.5. Test Software	9
2.6. Applied Standards	9
2.7. Test Environment Condition.....	10
3. Antenna Requirements	11
4. Measuring Instrument	12
5. Decision Rules and Measurement Uncertainty	13
5.1. Decision Rules.....	13
5.2. Measurement Uncertainty	13
6. Test Result.....	14
6.1. Summary	14
6.2. Output Power Measurement.....	15
6.2.1. Test Limit.....	15
6.2.2. Test Procedure	15
6.2.3. Test Setting	15
6.2.4. Test Setup.....	15
6.2.5. Test Result	15
6.3. Radiated Spurious Emission Measurement	16
6.3.1. Test Limit.....	16
6.3.2. Test Procedure	16
6.3.3. Test Setting	16
6.3.4. Test Setup.....	18
6.3.5. Test Result	19

6.4.	Radiated Restricted Band Edge Measurement	20
6.4.1.	Test Limit.....	20
6.4.2.	Test Procedure	22
6.4.3.	Test Setting	22
6.4.4.	Test Setup.....	23
6.4.5.	Test Result	23
Appendix A – Test Result		24
A.1	Output Power Test Result	24
A.2	Radiated Spurious Emission Test Result.....	25
A.3	Radiated Restricted Band Edge Test Result.....	26
Appendix B – Test Setup Photograph		30
Appendix C – EUT Photograph		31

1.4. Product Information

Product Name	AXE5400 Whole Home Mesh Wi-Fi 6E System
Model No.	Deco XE75, Deco XE5300, Deco XE75 Pro
EUT Identification No.	Sample#1-1 (Conducted) Sample#1-2 (Radiated)
Wi-Fi Specification	802.11a/b/g/n/ac/ax
Antenna Information	Refer to section 1.7
Accessory	
Adapter	MODEL: T120200-2B4 INPUT: 100 - 240V ~ 50/60Hz 0.8A. OUTPUT: 12.0V=2.0A Cable Out: Non-shielding, 1.2m
Note: The information of EUT was provided by the manufacturer, and the accuracy of the information shall be the responsibility of the manufacturer.	

1.5. Radio Specification under Test

Frequency Range	For 802.11a/n-HT20/ac-VHT20/ax-HE20: 5180~5240MHz, 5745~5825MHz For 802.11n-HT40/ac-VHT40/ax-HE40: 5190~5230MHz, 5755~5795MHz For 802.11ac-VHT80/ax-HE80: 5210MHz, 5775MHz For 802.11ac-VHT160/ax-HE160: 5250MHz
Type of Modulation	802.11a/n/ac: OFDM 802.11ax: OFDMA
Data Rate	802.11a: 6/9/12/18/24/36/48/54Mbps 802.11n: up to 300Mbps 802.11ac: up to 1733.3Mbps 802.11ax: up to 2402Mbps

1.6. Working Frequencies

802.11a/n-HT20/ac-VHT20/ax-HE20

Channel	Frequency	Channel	Frequency	Channel	Frequency
36	5180 MHz	40	5200 MHz	44	5220 MHz
48	5240 MHz	149	5745 MHz	153	5765 MHz
157	5785 MHz	161	5805 MHz	165	5825 MHz

802.11n-HT40/ac-VHT40/ax-HE40

Channel	Frequency	Channel	Frequency	Channel	Frequency
38	5190 MHz	46	5230 MHz	151	5755 MHz
159	5795 MHz	--	--	--	--

802.11ac-VHT80/ax-HE80

Channel	Frequency	Channel	Frequency	Channel	Frequency
42	5210 MHz	155	5775 MHz	--	--

802.11ac-VHT160/ax-HE160

Channel	Frequency	Channel	Frequency	Channel	Frequency
50	5250 MHz	--	--	--	--

1.7. Antenna Details

Antenna Type	Frequency Band (MHz)	Tx Paths	Max Antenna Gain (dBi)	CDD Directional Gain (dBi)	
				For Power	For PSD
Dipole Antenna	2412 ~ 2462	2	2.00	2.00	5.01
	5150 ~ 5350	2	1.00	1.00	4.01
	5725 ~ 5850	2	1.00	1.00	4.01

Note:

The EUT supports Cyclic Delay Diversity (CDD) mode, and CDD signals are correlated.

If all antennas have the same gain, G_{ANT} , Directional gain = G_{ANT} + Array Gain, where Array Gain is as follows.

- For power spectral density (PSD) measurements on all devices,
Array Gain = $10 \log (N_{ANT} / N_{SS})$ dB;
- For power measurements on IEEE 802.11 devices,
- Array Gain = 0 dB for $N_{ANT} \leq 4$;

2. Test Configuration

2.1. Test Details for Class II Perssive Change

C2PC Change List	Verified Test Item	Remark
Add “Deco XE75 Pro” in model names, the difference with previous models “Deco XE75, Deco XE5300” as follows: <ol style="list-style-type: none"> Ethernet chip is changed. The color and size of RJ45 connector is different. Wi-Fi 5G RF trace is moved. Shielding case of Wi-Fi 2G is different. 	Output Power	<ol style="list-style-type: none"> The output power: one channel of each mode and operating band was verified. Radiated Emission: worst case channel was verified.
	General Field Strength (Restricted Bands and Radiated Emission)	

Note: This product is an extension based on the FCC ID: 2AXJ4XE75V2, original grant date: December 28, 2022, the changes and verified item refer to the table as above.

2.2. Test Mode

CDD Mode
Mode 1: Transmit by 802.11a_Nss=1 (6Mbps)
Mode 2: Transmit by 802.11ac-VHT20_Nss=1 (MCS0)
Mode 3: Transmit by 802.11ac-VHT40_Nss=1 (MCS0)
Mode 4: Transmit by 802.11ac-VHT80_Nss=1 (MCS0)
Mode 5: Transmit by 802.11ac-VHT160_Nss=1 (MCS0)
Mode 6: Transmit by 802.11ax-HE20_Nss=1 (MCS0)
Mode 7: Transmit by 802.11ax-HE40_Nss=1 (MCS0)
Mode 8: Transmit by 802.11ax-HE80_Nss=1 (MCS0)
Mode 9: Transmit by 802.11ax-HE160_Nss=1 (MCS0)
Remark: <ol style="list-style-type: none"> For Radiated emission, the modulation and the data rate picked for testing are determined by the Max. RF conducted power. For CDD mode, this device supports 2 N_{ss} and power level is the same of spatial multiplexing. The worst case is N_{ss}=1. Due to the same modulation between 802.11n and 802.11ac, so 802.11n-HT20 and HT40 are covered by 802.11ac-VHT20 and VHT40 in this report, meanwhile, power level for 802.11n-HT20 and HT40 will not be greater than 802.11ac-VHT20 and VHT40. EUT supports one configuration only in 802.11ax full RU mode.

2.3. Test System Connection Diagram

The device was tested per the guidance ANSI C63.10: 2013 was used to reference the appropriate EUT setup for radiated emissions testing.

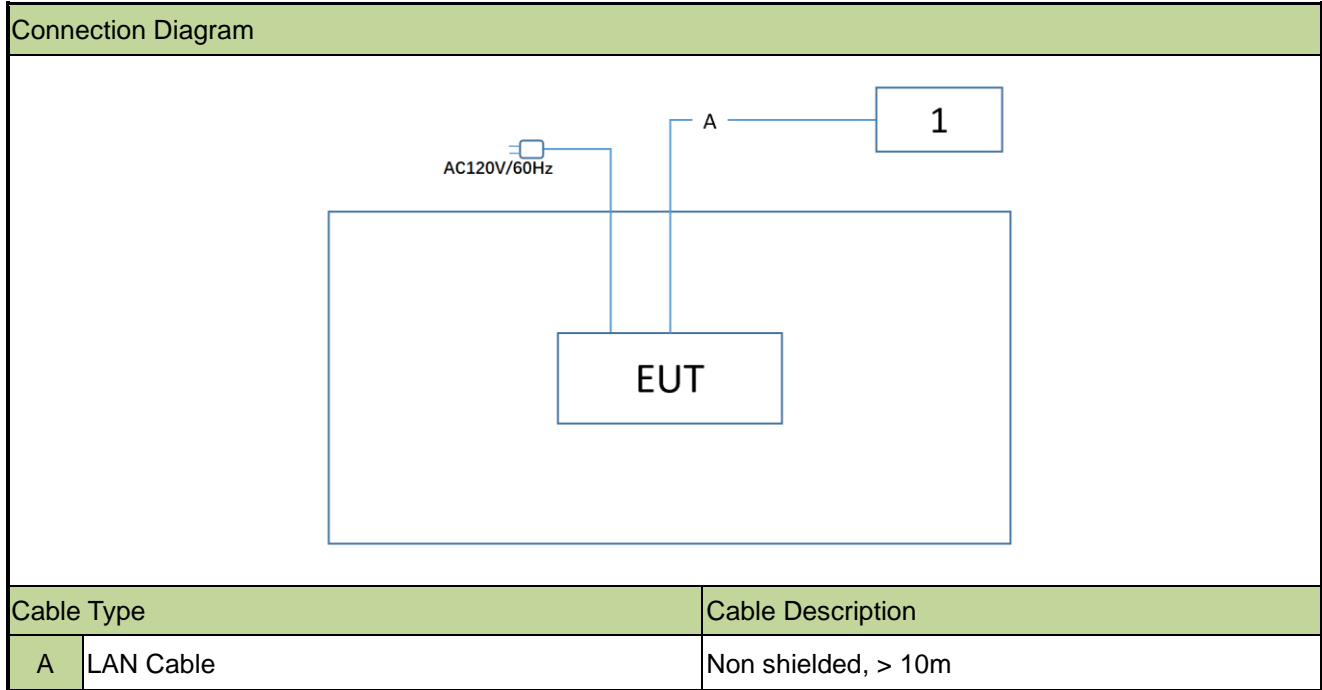

2.4. Test System Details

Product	Manufacturer	Model No.
1 Notebook	Lenovo	E431

2.5. Test Software

The test utility software used during testing was “QSPR”, the version is ver5.0-00188.

2.6. Applied Standards

According to the specifications of the manufacturer, the EUT must comply with the requirements of the following standards:

- FCC Part 15.407
- KDB 789033 D02v02r01
- KDB 662911 D01v02r01
- ANSI C63.10-2013

2.7. Test Environment Condition

Ambient Temperature	15 ~ 35°C
Relative Humidity	20 ~ 75%RH

3. Antenna Requirements

Excerpt from §15.203 of the FCC Rules/Regulations:

“An intentional radiator antenna shall be designed to ensure that no antenna other than that furnished by the responsible party can be used with the device. The use of a permanently attached antenna or of an antenna that uses a unique coupling to the intentional radiator shall be considered sufficient to comply with the provisions of this section.”

- The antenna of the device is **permanently attached**.
- There are no provisions for connection to an external antenna.

Conclusion:

The unit complies with the requirement of §15.203.

4. Measuring Instrument

Instrument	Manufacturer	Model No.	Asset No.	Cali. Interval	Cali. Due Date	Test Site
Horn Antenna	Schwarzbeck	BBHA 9170	MRTSUE06292	1 year	2023-10-18	NS-AC1
Anechoic Chamber	BOOMWAVE	NS-AC1	MRTSUE06496	1 year	2023-07-23	NS-AC1
Horn Antenna	Schwarzbeck	BBHA 9120D	MRTSUE06572	1 year	2023-04-01	NS-AC1
TRILOG Antenna	Schwarzbeck	VULB 9162	MRTSUE06573	1 year	2023-06-21	NS-AC1
Preamplifier	Schwarzbeck	BBV 9718	MRTSUE06574	1 year	2023-07-11	NS-AC1
EMI Test Receiver	R&S	ESR3	MRTSUE06575	1 year	2023-06-19	NS-AC1
Preamplifier	EMCI	EMC184045SE	MRTSUE06641	1 year	2023-01-13	NS-AC1
Thermohygrometer	testo	608-H1	MRTSUE11020	1 year	2023-05-15	NS-AC1
Thermohygrometer	testo	608-H1	MRTSUE11104	1 year	2023-05-03	NS-AC1
Signal Analyzer	Agilent	N9010A	MRTSUE06195	1 year	2023-04-13	NS-AC1/NS-TR2
Signal Analyzer	Keysight	N9020A	MRTSUE10065	1 year	2023-01-11	NS-AC1/NS-TR2
USB Power Sensor	Keysight	U2021XA	MRTSUE06581	1 year	2023-07-13	NS-TR2
Thermohygrometer	DELI	NO.8813	MRTSUE06783	1 year	2023-04-14	NS-TR2
Temperature Chamber	OUKE	OK-TH-100C	MRTSUE06899	1 year	2023-07-13	NS-TR2

Software	Version	Function
EMI Software	V3.0.0	EMI Test Software
Agilent Power Panel	V 3.9	Power

5. Decision Rules and Measurement Uncertainty

5.1. Decision Rules

The Decision Rule is based on Simple Acceptance in accordance with ISO Guide 98-4: 2012 Clause 8.2. (Measurement uncertainty is not taken into account when stating conformity with a specified requirement.)

5.2. Measurement Uncertainty

Where relevant, the following test uncertainty levels have been estimated for tests performed on the EUT as specified in CISPR 16-4-2. This uncertainty represents an expanded uncertainty expressed at approximately the 95% confidence level using a coverage factor of $k = 2$.

AC Conducted Emission Measurement
Measurement Uncertainty for a Level of Confidence of 95% ($U=2Uc(y)$): 9kHz~150kHz: 3.74dB 150kHz~30MHz: 3.44dB
Radiated Disturbance
Measurement Uncertainty for a Level of Confidence of 95% ($U=2Uc(y)$): Horizontal: 30MHz~300MHz: 5.04dB 300MHz~1GHz: 4.95dB 1GHz~40GHz: 6.40dB Vertical: 30MHz~300MHz: 5.24dB 300MHz~1GHz: 6.03dB 1GHz~40GHz: 6.40dB
Spurious Emissions, Conducted
Measuring Uncertainty for a Level of Confidence of 95% ($U=2Uc(y)$): 0.78dB
Output Power
Measuring Uncertainty for a Level of Confidence of 95% ($U=2Uc(y)$): 1.13dB
Power Spectrum Density
Measuring Uncertainty for a Level of Confidence of 95% ($U=2Uc(y)$): 1.15dB
Occupied Bandwidth
Measuring Uncertainty for a Level of Confidence of 95% ($U=2Uc(y)$): 0.28%

6. Test Result

6.1. Summary

FCC Section(s)	Test Description	Test Condition	Verdict
15.407(a)(1)(ii), (2), (3)(i)	Maximum Conducted Output Power	Conducted	Pass
15.205, 15.209 15.407(b)(8), (9), (10)	General Field Strength Limits (Restricted Bands and Radiated Emission Limits)	Radiated	Pass

Note:

1. The analyzer plots shown in this section were all taken with a correction table loaded into the analyzer. The correction table was used to account for the losses of the cables and attenuators used as part of the system to connect the EUT to the analyzer at all frequencies of interest.

6.2. Output Power Measurement

6.2.1. Test Limit

For the band 5.15-5.25 GHz, the maximum conducted output power over the frequency band of operation shall not exceed 1 W provided the maximum antenna gain does not exceed 6 dBi.

For the 5.25-5.35 GHz and 5.47-5.725 GHz bands, the maximum conducted output power over the frequency bands of operation shall not exceed the lesser of 250 mW or $11 \text{ dBm} + 10 \log B$, where B is the 26 dB emission bandwidth in megahertz.

For the band 5.725-5.85 GHz, the maximum conducted output power over the frequency band of operation shall not exceed 1 W (30dBm).

If transmitting antennas of directional gain greater than 6dBi are used, the maximum conducted output power shall be reduced by the amount in dB that the directional gain of the antenna exceeds 6dBi.

6.2.2. Test Procedure

KDB 789033D02v02r01- Section II)E)3)b) Method PM-G

6.2.3. Test Setting

Average Power Measurement

Average power measurements were performed only when the EUT was transmitting at its maximum power control level using a broadband power meter with a pulse sensor. The power meter implemented triggering and gating capabilities which were set up such that power measurements were recorded only during the ON time of the transmitter.

6.2.4. Test Setup

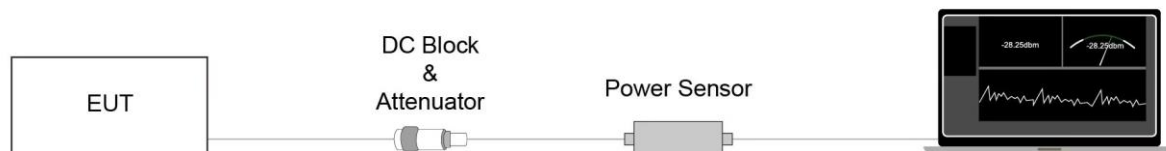

6.2.5. Test Result

Refer to Appendix A.1.

6.3. Radiated Spurious Emission Measurement

6.3.1. Test Limit

All out of band emissions appearing in a restricted band as specified in Section 15.205 of the Title 47 CFR must not exceed the limits shown in Table per Section 15.209.

FCC Part 15 Subpart C Paragraph 15.209		
Frequency [MHz]	Field Strength [uV/m]	Measured Distance [Meters]
0.009 - 0.490	2400/F (kHz)	300
0.490 - 1.705	24000/F (kHz)	30
1.705 - 30	30	30
30 - 88	100	3
88 - 216	150	3
216 - 960	200	3
Above 960	500	3

6.3.2. Test Procedure

KDB 789033 D02v02r01- Section II)G)

6.3.3. Test Setting

Table 1 - RBW as a function of frequency

Frequency	RBW
9 ~ 150 kHz	200 ~ 300 Hz
0.15 ~ 30 MHz	9 ~ 10 kHz
30 ~ 1000 MHz	100 ~ 120 kHz
> 1000MHz	1MHz

Quasi-Peak Measurements below 1GHz

1. Analyzer center frequency was set to the frequency of the radiated spurious emission of interest
2. Span was set greater than 1MHz
3. RBW = as specified in Table 1
4. Detector = CISPR quasi-peak
5. Sweep time = auto couple
6. Trace was allowed to stabilize

Peak Measurements above 1GHz

1. Analyzer center frequency was set to the frequency of the radiated spurious emission of interest
2. RBW = 1MHz
3. VBW = 3MHz
4. Detector = peak
5. Sweep time = auto couple
6. Trace mode = max hold
7. Trace was allowed to stabilize

Average Measurements above 1GHz (Method VB)

1. Analyzer center frequency was set to the frequency of the radiated spurious emission of interest
2. RBW = 1MHz
3. VBW; If the EUT is configured to transmit with duty cycle $\geq 98\%$, set VBW = 10 Hz.
If the EUT duty cycle is $< 98\%$, set VBW $\geq 1/T$. T is the minimum transmission duration.
4. Detector = Peak
5. Sweep time = auto
6. Trace mode = max hold
7. Trace was allowed to stabilize

6.3.4. Test Setup

Below 30MHz Test Setup:

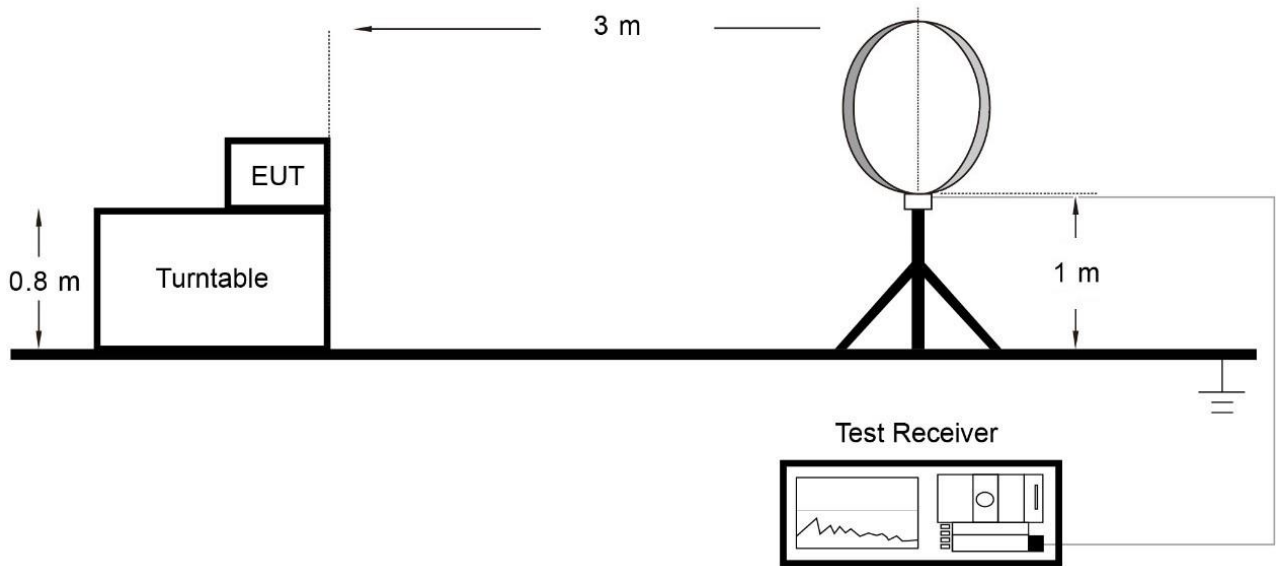

Below 1GHz Test Setup:

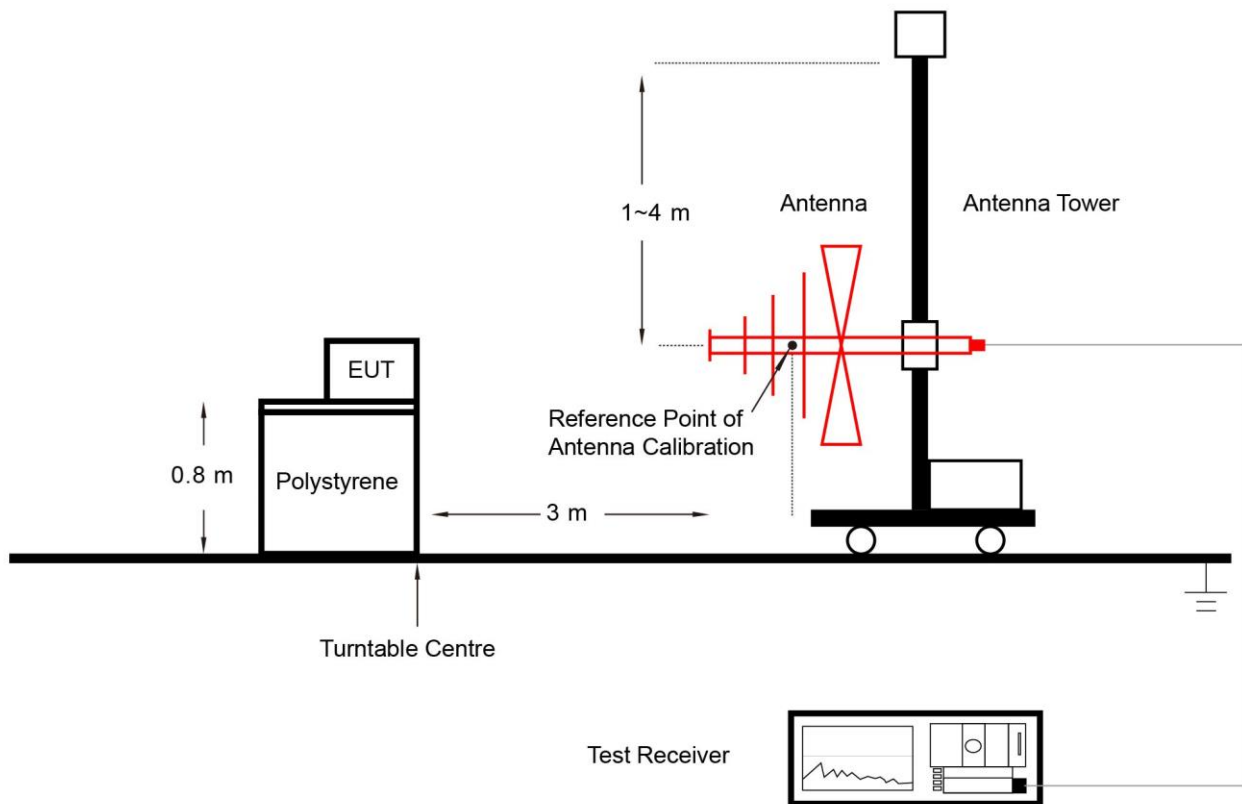

Above 1GHz Test Setup:

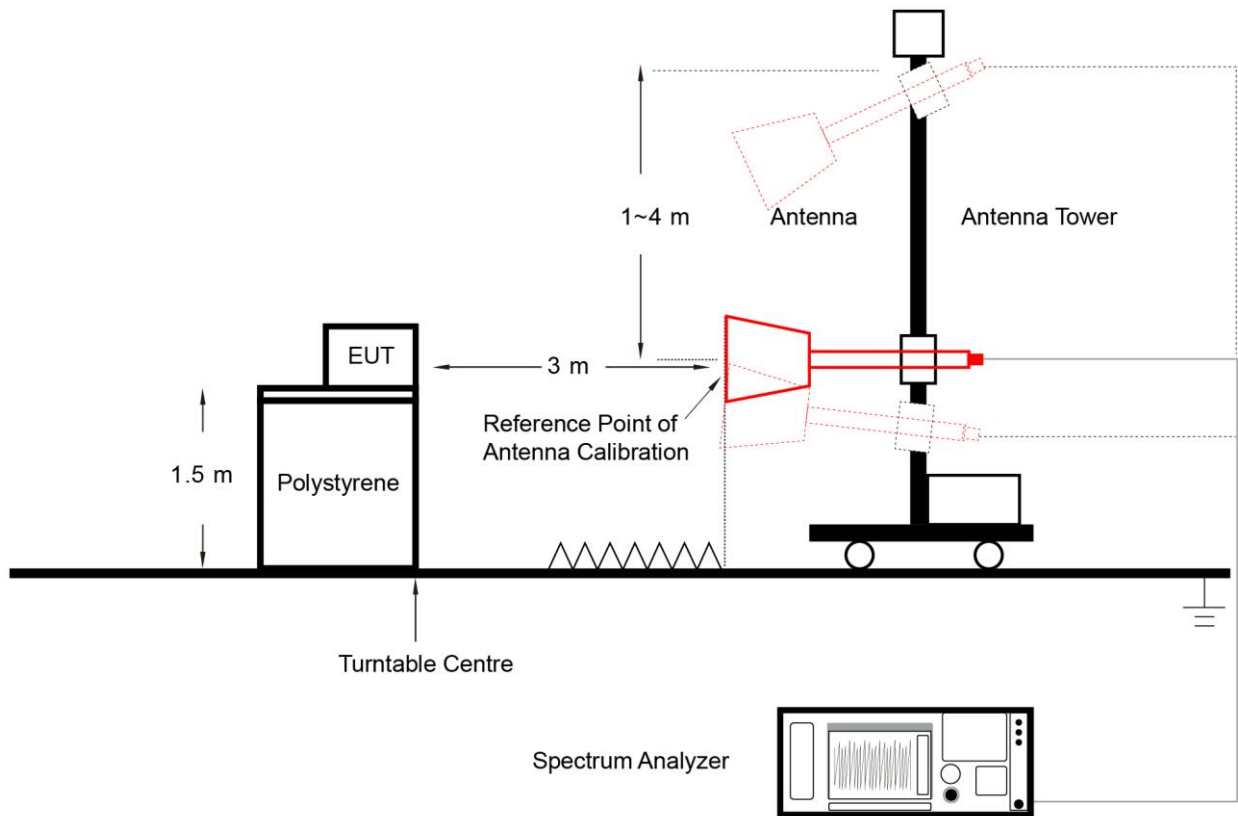

6.3.5. Test Result

Refer to Appendix A.2.

6.4. Radiated Restricted Band Edge Measurement

6.4.1. Test Limit

For 15.205 requirement:

Radiated emissions which fall in the restricted bands, as defined in Section 15.205(a) of FCC part 15, must also comply with the radiated emission limits specified in Section 15.209(a).

Frequency (MHz)	Frequency (MHz)	Frequency (MHz)	Frequency (GHz)
0.090 - 0.110	16.42 - 16.423	399.9 - 410	4.5 - 5.15
¹ 0.495 - 0.505	16.69475 - 16.69525	608 - 614	5.35 - 5.46
2.1735 - 2.1905	16.80425 - 16.80475	960 - 1240	7.25 - 7.75
4.125 - 4.128	25.5 - 25.67	1300 - 1427	8.025 - 8.5
4.17725 - 4.17775	37.5 - 38.25	1435 - 1626.5	9.0 - 9.2
4.20725 - 4.20775	73 - 74.6	1645.5 - 1646.5	9.3 - 9.5
6.215 - 6.218	74.8 - 75.2	1660 - 1710	10.6 - 12.7
6.26775 - 6.26825	108 - 121.94	1718.8 - 1722.2	13.25 - 13.4
6.31175 - 6.31225	123 - 138	2200 - 2300	14.47 - 14.5
8.291 - 8.294	149.9 - 150.05	2310 - 2390	15.35 - 16.2
8.362 - 8.366	156.52475 - 156.52525	2483.5 - 2500	17.7 - 21.4
8.37625 - 8.38675	156.7 - 156.9	2690 - 2900	22.01 - 23.12
8.41425 - 8.41475	162.0125 - 167.17	3260 - 3267	23.6 - 24.0
12.29 - 12.293	167.72 - 173.2	3332 - 3339	31.2 - 31.8
12.51975 - 12.52025	240 - 285	3345.8 - 3358	36.43 - 36.5
12.57675 - 12.57725	322 - 335.4	3600 - 4400	(²)
13.36 - 13.41	--	--	--

For 15.407(b) requirement:

For transmitters operating in the 5.15-5.25 GHz band: All emissions outside of the 5.15-5.35 GHz band shall not exceed an e.i.r.p. of -27 dBm/MHz.

For transmitters operating in the 5.25-5.35 GHz band: All emissions outside of the 5.15-5.35 GHz band shall not exceed an e.i.r.p. of -27 dBm/MHz.

For transmitters operating in the 5.47-5.725 GHz band: All emissions outside of the 5.47-5.725 GHz band shall not exceed an e.i.r.p. of -27 dBm/MHz.

For transmitters operating in the 5.725-5.85 GHz band: All emissions shall be limited to a level of -27 dBm/MHz at 75 MHz or more above or below the band edge increasing linearly to 10 dBm/MHz at 25 MHz above or below the band edge, and from 25 MHz above or below the band edge increasing linearly to a level of 15.6 dBm/MHz at 5 MHz above or below the band edge, and from 5 MHz above or below the band edge increasing linearly to a level of 27 dBm/MHz at the band edge.

Refer to KDB 789033 D02v02r01 G)2)c), as specified in § 15.407(b), emissions above 1000 MHz that are outside of the restricted bands are subject to a maximum emission limit of -27 dBm/MHz (or -17 dBm/MHz as specified in § 15.407(b)(4)). However, an out-of-band emission that complies with both the peak and average limits of § 15.209 is not required to satisfy the -27 dBm/MHz or -17 dBm/MHz maximum emission limit.

All out of band emissions appearing in a restricted band as specified in Section 15.205 of the Title 47CFR must not exceed the limits shown in Table per Section 15.209.

FCC Part 15 Subpart C Paragraph 15.209		
Frequency [MHz]	Field Strength [uV/m]	Measured Distance [Meters]
0.009 - 0.490	2400/F (kHz)	300
0.490 - 1.705	24000/F (kHz)	30
1.705 - 30	30	30
30 - 88	100	3
88 - 216	150	3
216 - 960	200	3
Above 960	500	3

6.4.2. Test Procedure

KDB 789033 D02v02r01- Section II)G)

6.4.3. Test Setting

Peak Measurements above 1GHz

1. Analyzer center frequency was set to the frequency of the radiated spurious emission of interest
2. RBW = 1MHz
3. VBW = 3MHz
4. Detector = Peak
5. Sweep time = Auto couple
6. Trace mode = Max hold
7. Trace was allowed to stabilize

Average Measurements above 1GHz (Method VB)

1. Analyzer center frequency was set to the frequency of the radiated spurious emission of interest
2. RBW = 1MHz
3. VBW; if the EUT is configured to transmit with duty cycle $\geq 98\%$, set VBW = 10Hz
4. If the EUT duty cycle is $< 98\%$, set VBW $\geq 1/T$. T is the minimum transmission duration
5. Detector = Peak
6. Sweep time = Auto
7. Trace mode = Max hold
8. Trace was allowed to stabilize

6.4.4. Test Setup

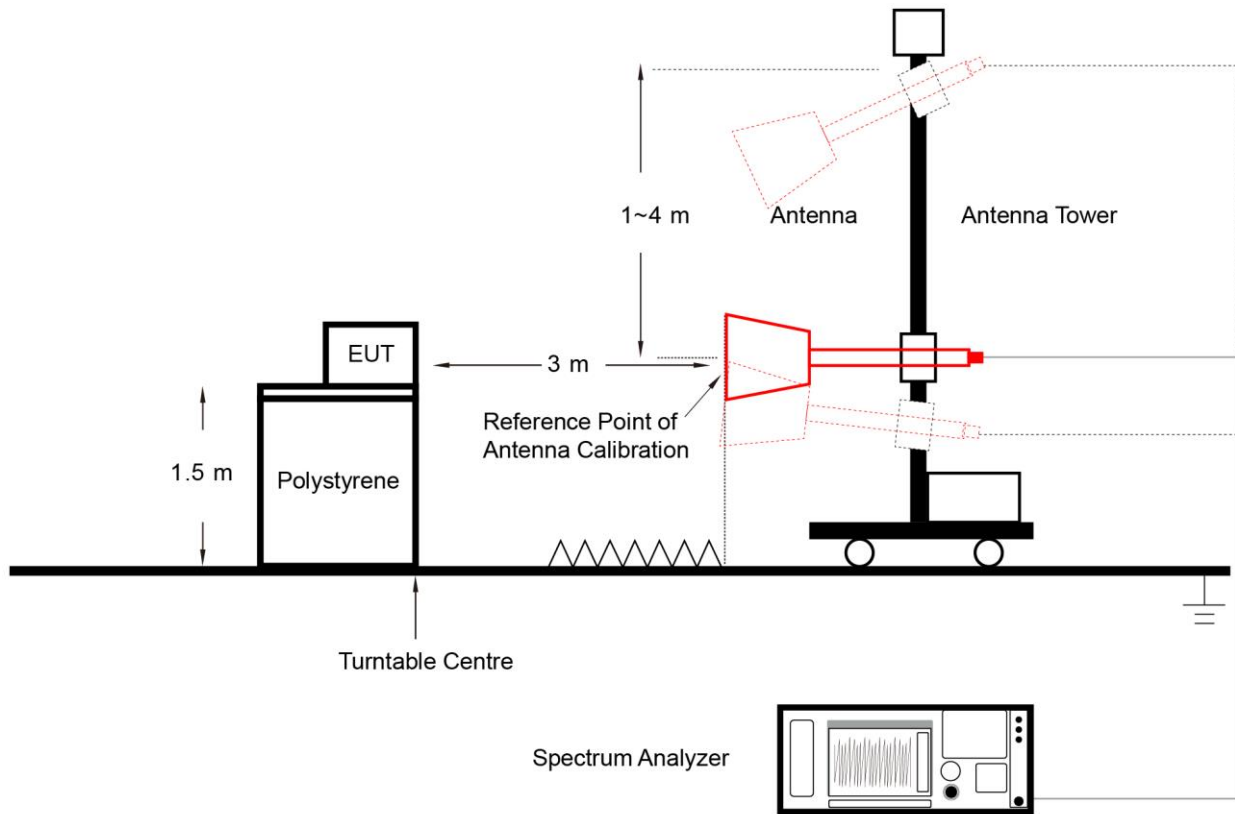

6.4.5. Test Result

Refer to Appendix A.3.

Appendix A – Test Result

A.1 Output Power Test Result

Test Site	NS-TR2	Test Engineer	Flag Yang
Test Date	2022-12-02		

Test Mode	Data Rate MCS	Channel No.	Freq. (MHz)	Average Power (dBm)		Total Average Power (dBm)	Average Power Limit (dBm)
				Ant 0	Ant 1		
11a	6Mbps	48	5240	23.68	24.05	26.88	≤ 30.00
11a	6Mbps	165	5825	25.66	26.01	28.85	≤ 30.00
11ac-VHT20	MCS0	44	5220	24.11	24.50	27.32	≤ 30.00
11ac-VHT20	MCS0	157	5785	25.32	26.09	28.73	≤ 30.00
11ac-VHT40	MCS0	46	5230	26.34	26.03	29.20	≤ 30.00
11ac-VHT40	MCS0	159	5795	26.48	25.90	29.21	≤ 30.00
11ac-VHT80	MCS0	42	5210	20.99	21.37	24.19	≤ 30.00
11ac-VHT80	MCS0	155	5775	22.10	21.87	25.00	≤ 30.00
11ac-VHT160	MCS0	50	5250	19.34	19.44	22.40	≤ 23.98
11ax-HE20	MCS0	48	5240	24.50	24.89	27.71	≤ 30.00
11ax-HE20	MCS0	157	5785	25.59	26.08	28.85	≤ 30.00
11ax-HE40	MCS0	46	5230	26.22	26.15	29.20	≤ 30.00
11ax-HE40	MCS0	159	5795	26.54	25.83	29.21	≤ 30.00
11ax-HE80	MCS0	42	5210	21.06	21.52	24.31	≤ 30.00
11ax-HE80	MCS0	155	5775	21.74	21.54	24.65	≤ 30.00
11ax-HE160	MCS0	50	5250	19.69	19.79	22.75	≤ 23.98

Note: Total Average Power (dBm) = $10 \cdot \log \{10^{(\text{Ant 0 Average Power} / 10)} + 10^{(\text{Ant 1 Average Power} / 10)}\}$.

A.2 Radiated Spurious Emission Test Result

Test Site	NS-AC1	Test Engineer	Flag Yang
Test Date	2022-12-08	Test Mode	802.11a – Channel 48
Remark	1. Average measurement was not performed if peak level lower than average limit. 2. Other frequency was 20dB below limit line within 1-18GHz, there is not show in the report.		

Mark	Frequency (MHz)	Reading Level (dBμV)	Factor (dB/m)	Measure Level (dBμV/m)	Limit (dBμV/m)	Margin (dB)	Detector	Polarization
	8386.500	41.1	10.0	51.1	74	-22.817	Peak	Horizontal
*	10188.500	34.5	12.9	47.4	68.2	-20.774	Peak	Horizontal
*	12891.500	33.7	15.3	49.0	68.2	-19.151	Peak	Horizontal
	15713.500	45.3	16.0	61.3	74	-12.729	Peak	Horizontal
	15718.975	33.2	15.9	49.1	54	-4.929	Average	Horizontal
	8386.500	37.9	10.0	47.9	74	-26.109	Peak	Vertical
*	10265.000	34.7	13.1	47.8	68.2	-20.43	Peak	Vertical
*	13843.500	33.7	16.9	50.6	68.2	-17.655	Peak	Vertical
	15719.125	29.1	15.9	45.0	54	-9.017	Average	Vertical
	15722.000	41.6	15.9	57.5	74	-16.55	Peak	Vertical

Note 1: "*" is not in restricted band, its limit is -27dBm/MHz. At a distance of 3 meters, the field strength limit in dBμV/m can be determined by adding a "conversion" factor of 95.2dB to the EIRP limit of -27dBm/MHz to obtain the limit for out of band spurious emissions.

Note 2: Measure Level (dBμV/m) = Reading Level (dBμV) + Factor (dB/m)

Factor (dB/m) = Cable Loss (dB) + Antenna Factor (dB/m) - Pre_Amplifier Gain (dB)

A.3 Radiated Restricted Band Edge Test Result

Site: NS-AC1	Time: 2022/12/20 - 15:38
Limit: FCC_5G_RE(3m)	Engineer: Flag Yang
Probe: NS-AC1_BBHA9120D_2111_1-18GHz	Polarity: Horizontal
EUT: AXE5400 Whole Home Mesh Wi-Fi 6E System	Power: AC 120V/60Hz
Test Mode: Transmit by 802.11ac-VHT80 at 5210MHz	

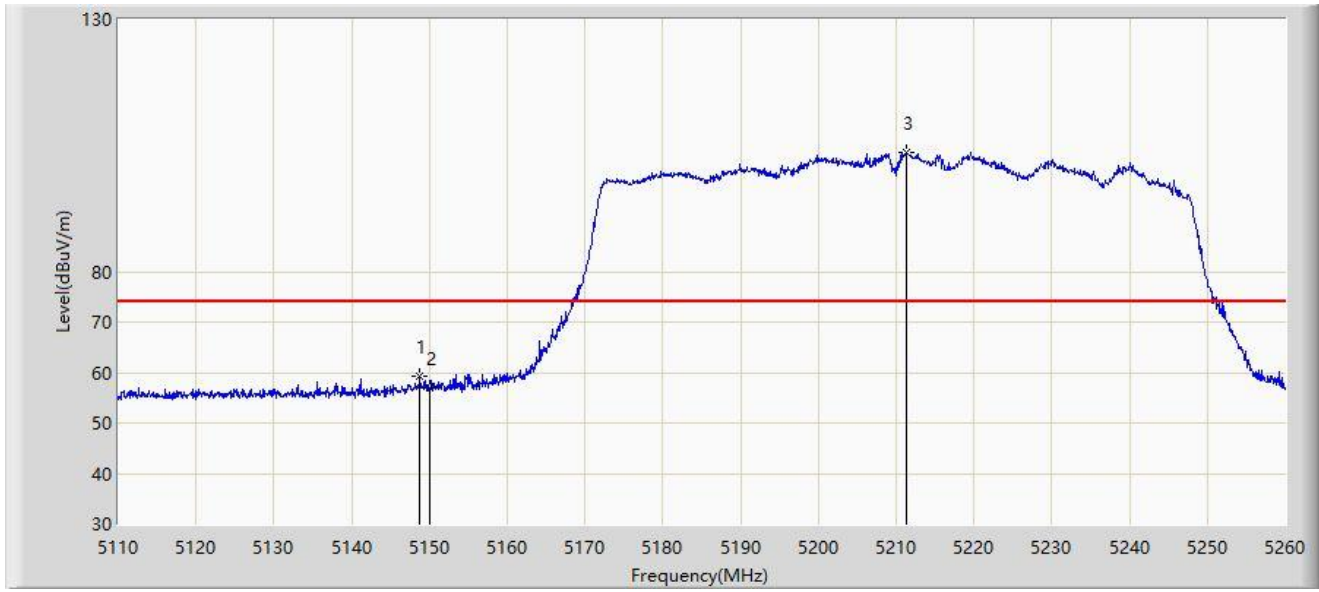

No	Mark	Frequency (MHz)	Measure Level (dBμV/m)	Reading Level (dBμV)	Margin (dB)	Limit (dBμV/m)	Factor (dB/m)	Type
1	*	5148.775	59.259	56.585	-14.741	74.000	2.674	PK
2		5150.000	56.863	54.197	-17.137	74.000	2.665	PK
3		5211.250	103.723	101.556	N/A	N/A	2.166	PK

Note 1: " * ", means this data is the worst emission level.

Note 2: Measure Level (dBμV/m) = Reading Level (dBμV) + Factor (dB/m).

Note 3: Factor (dB/m) = Cable Loss (dB) + Antenna Factor (dB/m) - Pre_Amplifier Gain (dB).

Site: NS-AC1	Time: 2022/12/20 - 15:43
Limit: FCC_5G_RE(3m)	Engineer: Flag Yang
Probe: NS-AC1_BBHA9120D_2111_1-18GHz	Polarity: Horizontal
EUT: AXE5400 Whole Home Mesh Wi-Fi 6E System	Power: AC 120V/60Hz
Test Mode: Transmit by 802.11ac-VHT80 at 5210MHz	

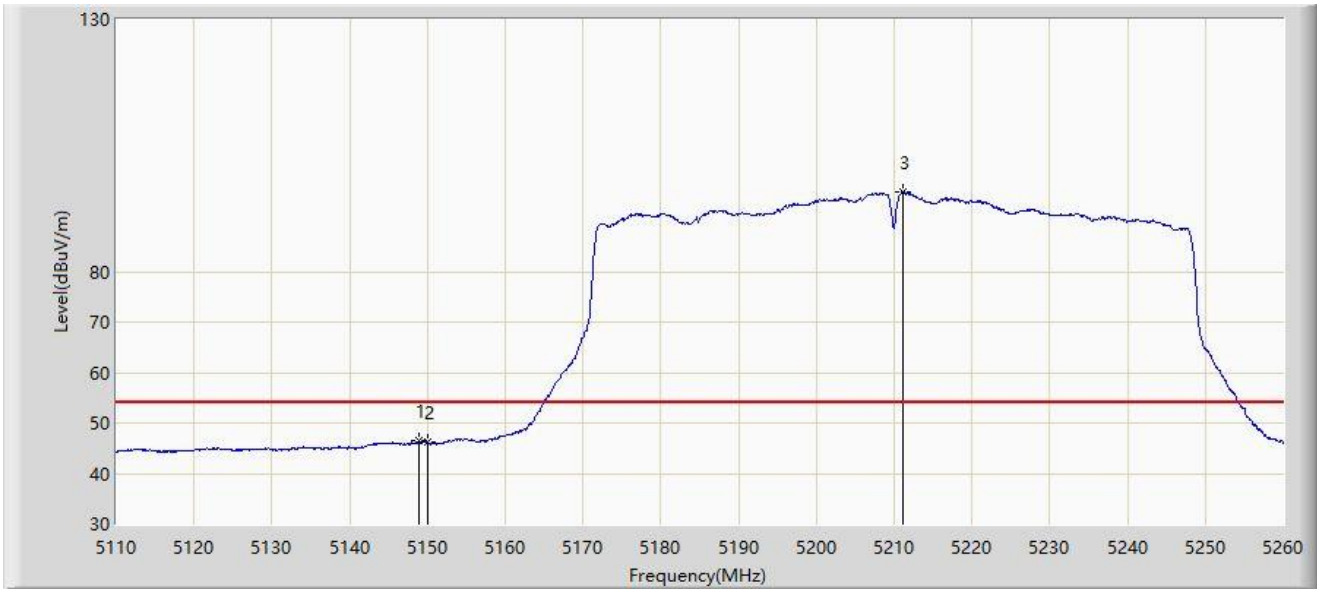

No	Mark	Frequency (MHz)	Measure Level (dB μ V/m)	Reading Level (dB μ V)	Margin (dB)	Limit (dB μ V/m)	Factor (dB/m)	Type
1	*	5149.000	46.438	43.765	-7.562	54.000	2.673	AV
2		5150.000	46.161	43.495	-7.839	54.000	2.665	AV
3		5211.100	95.729	93.566	N/A	N/A	2.163	AV

Note 1: " * ", means this data is the worst emission level.

Note 2: Measure Level (dB μ V/m) = Reading Level (dB μ V) + Factor (dB/m).

Note 3: Factor (dB/m) = Cable Loss (dB) + Antenna Factor (dB/m) - Pre_Amplifier Gain (dB).

Site: NS-AC1	Time: 2022/12/20 - 15:48
Limit: FCC_5G_RE(3m)	Engineer: Flag Yang
Probe: NS-AC1_BBHA9120D_2111_1-18GHz	Polarity: Vertical
EUT: AXE5400 Whole Home Mesh Wi-Fi 6E System	Power: AC 120V/60Hz
Test Mode: Transmit by 802.11ac-VHT80 at 5210MHz	

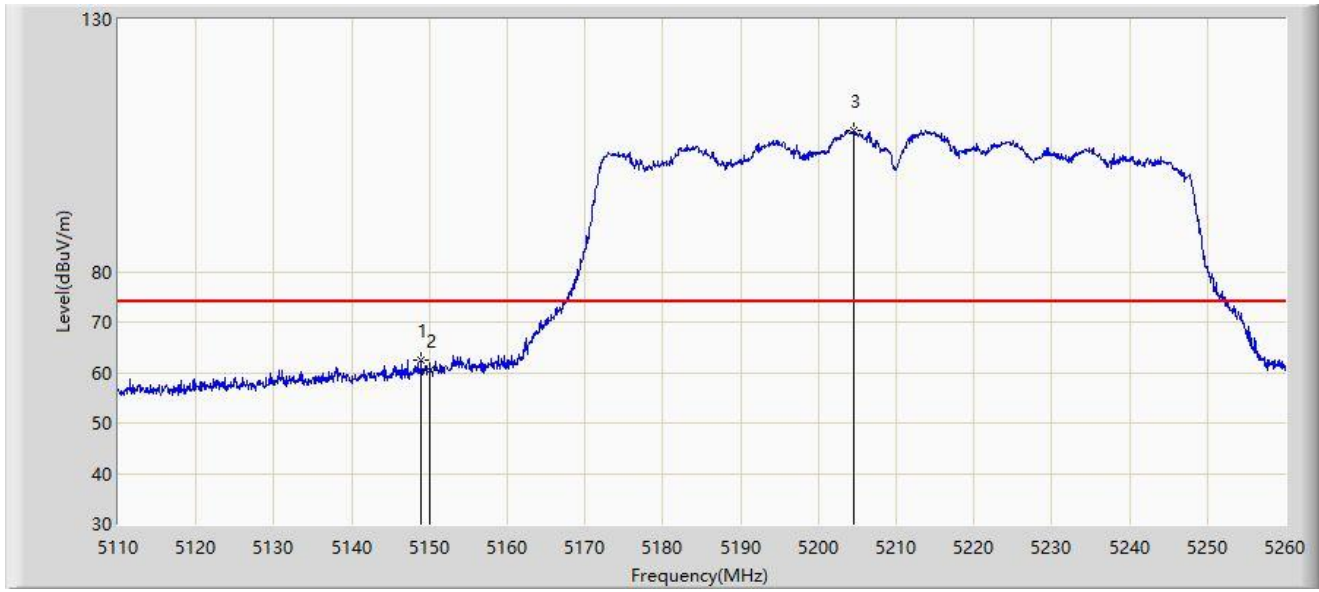

No	Mark	Frequency (MHz)	Measure Level (dB μ V/m)	Reading Level (dB μ V)	Margin (dB)	Limit (dB μ V/m)	Factor (dB/m)	Type
1	*	5149.000	62.586	59.913	-11.414	74.000	2.673	PK
2		5150.000	60.576	57.910	-13.424	74.000	2.665	PK
3		5204.575	108.108	106.113	N/A	N/A	1.995	PK

Note 1: " * ", means this data is the worst emission level.

Note 2: Measure Level (dB μ V/m) = Reading Level (dB μ V) + Factor (dB/m).

Note 3: Factor (dB/m) = Cable Loss (dB) + Antenna Factor (dB/m) - Pre_Amplifier Gain (dB).

Site: NS-AC1	Time: 2022/12/20 - 15:50
Limit: FCC_5G_RE(3m)	Engineer: Flag Yang
Probe: NS-AC1_BBHA9120D_2111_1-18GHz	Polarity: Vertical
EUT: AXE5400 Whole Home Mesh Wi-Fi 6E System	Power: AC 120V/60Hz
Test Mode: Transmit by 802.11ac-VHT80 at 5210MHz	

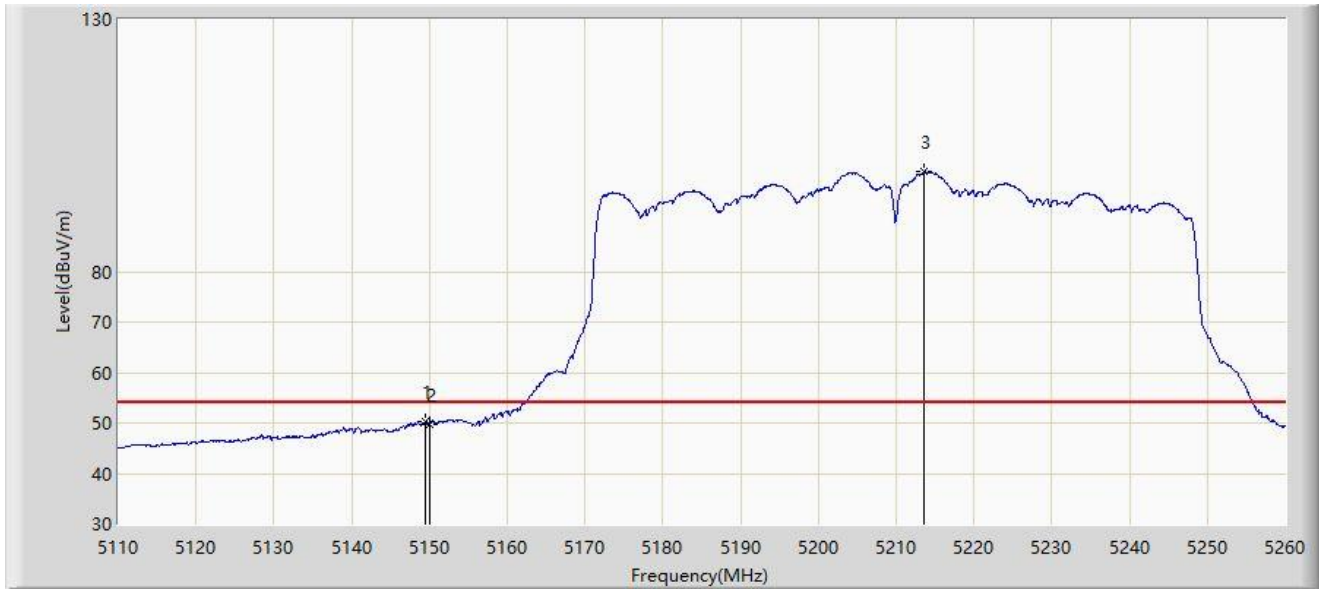

No	Mark	Frequency (MHz)	Measure Level (dBμV/m)	Reading Level (dBμV)	Margin (dB)	Limit (dBμV/m)	Factor (dB/m)	Type
1	*	5149.525	50.333	47.664	-3.667	54.000	2.670	AV
2		5150.000	49.758	47.092	-4.242	54.000	2.665	AV
3		5213.650	99.735	97.507	N/A	N/A	2.227	AV

Note 1: " * ", means this data is the worst emission level.

Note 2: Measure Level (dBμV/m) = Reading Level (dBμV) + Factor (dB/m).

Note 3: Factor (dB/m) = Cable Loss (dB) + Antenna Factor (dB/m) - Pre_Amplifier Gain (dB).

Appendix B – Test Setup Photograph

Refer to “2211RSU084-UT” file.

Appendix C – EUT Photograph

Refer to “2211RSU084-UE” file.

_____ The End _____