



black box

Power Amplifier Instruction Manual

To ensure maximum performance and safety, please follow this manual. Please retain the manual for future reference after installation

**STEREO 2
STEREO 4
BASS 1**

OWNERS MANUAL

Model: BLACKBOX STEREO 2 / STEREO 4 / BASS 1

Congratulations on purchasing your VIBE BlackBox amplifier. Please read this manual in order to fully understand how to get the best results from your amplifier.

Please ensure that all advice on how to look after your amplifier is followed.

Thank you for buying VIBE, we hope you enjoy listening to your product as much as we enjoyed creating it.

VIBE R&D Division

Mounting Guidelines

Your VIBE amplifier is designed with a swift installation routine in mind. Please mount the amplifier in a dry location on a solid surface. NEVER mount the amplifier upside down, this will cause the amplifier to over heat and will eventually damage the amplifier. Before fixing the amplifier in place please ensure that there is sufficient air flow around the exterior of the casing, at least two inches is sufficient.

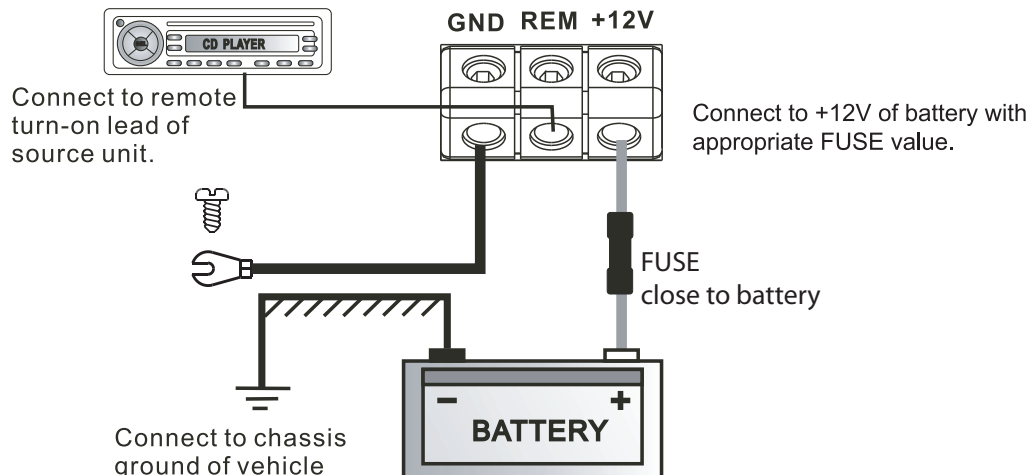

Connections

Ground Cable

- The ground cable needs to carry the same current as the power cable. At least an 8 gauge cable should be used.
- The amplifier ground should be connected directly to the chassis of the vehicle, to bare metal.
- The cable length should be kept to an absolute minimum.
- It is not recommended that you connect the ground cable to the vehicles seatbelts anchor point.

Remote Turn On

- A minimum of 18 gauge cable should be used for this connection.
- The cable should be run with exactly the same care and attention as the power cable and taken back to the source (headunit) and joined to the remote cable provided.
- If the source (headunit) does not have a remote turn on cable then a 12v supply should be used. This will require a switch to be fitted inline to enable the amplifier to be turned on and off. Remember that if this switch is left on you will flatten the car battery.

RCA Cables

- Depending on the model number of your amplifier and the number of speakers you wish to power you will have to run either one or two RCA cables from the source to the amplifier.
- Please take extra care when running these cables from the source to the amplifier. Ensure that they are placed away from all items that can generate any interference, wiring harnesses etc.
- It is recommended that the RCA cables should be run on opposite sides of the car to the previously installed power cables if possible, to avoid the cable picking up interference.

Power Cable

- At least an 8 gauge cable should be used for both the power and the ground connections to the amplifier.
- The power cable should be taken directly from the battery. Rubber grommets should be used when passing through any bulkheads to prevent the cable from becoming chaffed or cut.
- It is vital that a fuse / circuit breaker (of at least equal value to the one fitted on the amplifier) is placed inline with the power cable and is no further than eighteen inches away from the battery.
- Please ensure that the fuse is not fitted until the entire installation procedure is complete.
- The two tables below are to help you decide on what cable is correct for you. The first enables you to select the size of cable depending on the length required. The second will help you convert the cable size from American Wire Gauge to Metric if you need to.

Current demand	Length of Run							
	0 - 4 Ft	4 - 7 Ft	7 - 10 Ft	10 - 13 Ft	13 - 16 Ft	16 - 19 Ft	19 - 22 Ft	22 - 28 Ft
0-20 amps	14	12	12	10	10	8	8	8
20-35 amps	12	10	8	8	6	6	6	4
35-50 amps	10	8	8	6	4	4	4	4
50-65 amps	8	8	6	4	4	4	4	2
65-85 amps	6	6	4	4	2	2	2	0
85-105 amps	6	6	4	2	2	2	2	0
105-125 amps	4	4	4	2	0	0	0	0
125-150 amps	2	2	2	0	0	0	0	0

AWG to Metric Conversion Chart cross sectional area			
AWG Number	Inch	mm	mm ²
0	0.325	8.25	53.5
1	0.289	7.35	42.4
2	0.258	6.54	33.6
3	0.229	5.83	26.7
4	0.204	5.19	21.1
5	0.182	4.62	16.8
6	0.162	4.11	13.3
7	0.144	3.66	10.5
8	0.128	3.26	8.36
9	0.114	2.91	6.63
10	0.102	2.59	5.2

Connections and Controls - BlackBox Stereo 2

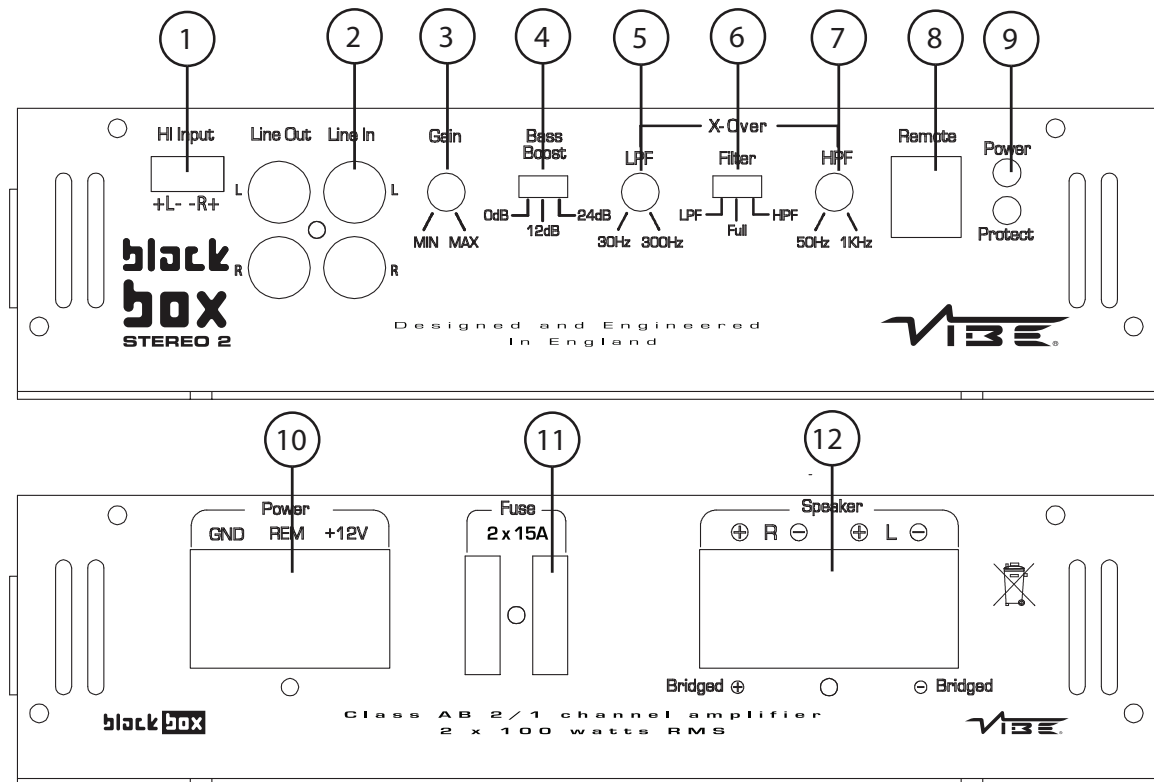

1. High Level Input

To be used when no RCA's are available. Use the provided loom to connect to closest speakers. The loom connector will only fit one way around. Once plugged in you should connect the wires as below:

2. Low Level Input / Output

Low level input connection to any source (head unit) with a low level output. This is your RCA output from the source (headunit)

Low level output is a daisy chain RCA connection to allow easy addition of another amplifier.

3. Gain Control

Used to match the input signal of the source to the amplifier. See the setup section for more details.

4. Bass Boost Switch

To provide up to an extra +24 dB of bass boost at 45 Hz. Use this boost to increase bass output from the amplifier.

5. Low Pass Crossover Control

The control is used to select the low pass filter frequency. The frequency ranges are from 30 Hz to 300 Hz.

6. Crossover Control Switch

This switch is used to select high pass, low pass or full (no crossover) operation for the amplifier speaker outputs.

7. High Pass Crossover Control

The control is used to select the high pass filter frequency. The frequency ranges are from 50 Hz to 1KHz.

8. Gain Remote Input Jack

Use to plug in the remote bass controller. (BBR09 optional) see website for details www.vibeaudio.co.uk

9. Indicator LEDs

When the amplifier is operating correctly the green LED will illuminate. When the amplifier is in protection mode the red LED will illuminate

10. Power Connections

Power connections. See Connections section for details on correct connections.

11. Fuses

Please ensure the following fuse rating is used when replacing fuses: 15 amp x 2

12. Speaker Terminal Output

For connection to the speakers. See Application section for wiring examples.

Applications - BlackBox Stereo 2

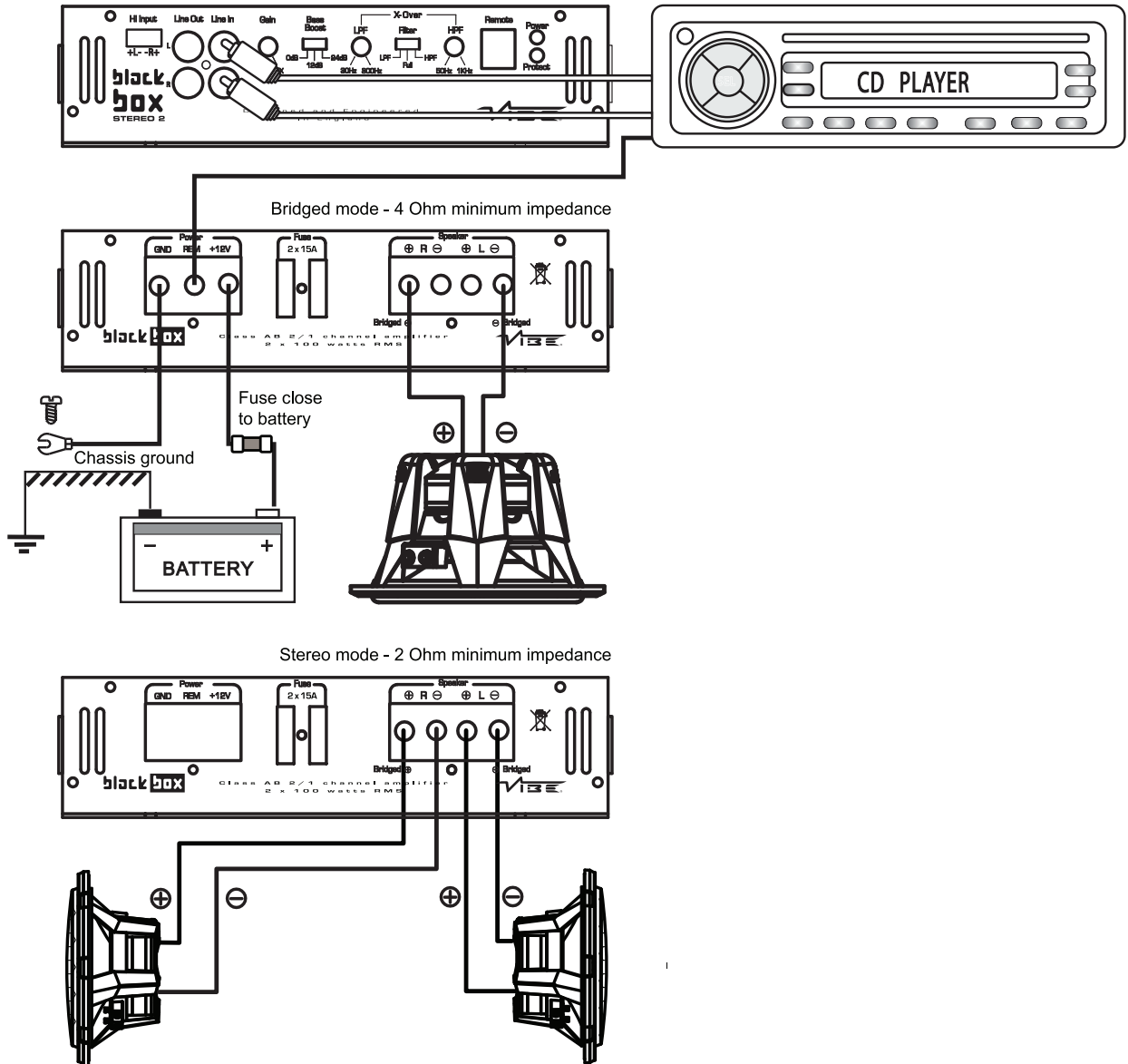

Connections and Controls - BlackBox Stereo 4

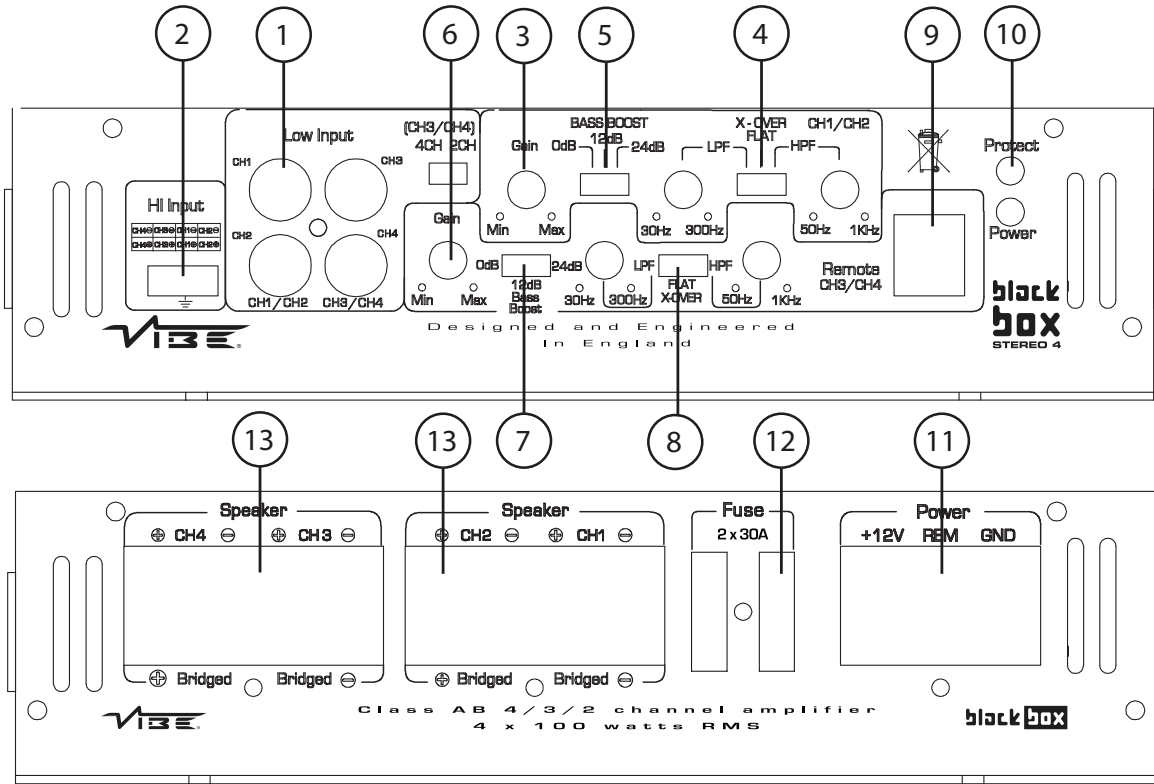

1. Low Level Input

For connection to any source (head unit) with a low level output. This is your RCA output from the source (headunit). In order to obtain a four channel output from a two channel input please set the switch to 4 channel and plug the RCA's into channel 3 and channel 4.

2. High Level Input

To be used when no RCA's are available. Use the provided loom to connect to closest speakers. The loom connector will only fit one way around. Once plugged in you should connect the wires as below:

Front Speakers

Left Positive - Brown
Left Negative - Blue

Right Positive - Black
Right Negative - Green

Rear Speakers

Left Positive - Orange
Left Negative - Grey

Right Positive - Yellow
Left Negative - White

3. Front Gain Control

Used to match the input signal of the source to the amplifier. See the setup section for more details.

4. Front Crossover Control

The switch is used to select between low pass / high pass filter or no filter at all on the front channels. The frequency ranges on the low pass filter are from 30 Hz to 300 Hz. The frequency ranges on the high pass filter are from 50 Hz to 1KHz.

5. Front Bass Boost Switch

To provide up to an extra +24 dB of bass boost at 45 Hz. Use this boost to increase bass output from the amplifier.

6. Rear Gain Control

Used to match the input signal of the source to the amplifier. See the setup section for more details.

7. Rear Bass Boost Switch

To provide up to an extra +24 dB of bass boost at 45 Hz. Use this boost to increase bass output from the amplifier.

8. Rear Crossover Control

The switch is used to select between low pass / high pass filter or no filter at all on the rear channels. The frequency ranges on the low pass filter are from 30 Hz to 300 Hz. The frequency ranges on the high pass filter are from 50 Hz to 1KHz.

9. Rear Gain Remote Input Jack

Use to plug in the remote bass controller. [BBR09 optional] see website for details www.vibeaudio.co.uk

10. Indicator LEDs

When the amplifier is operating correctly the green LED will illuminate. When the amplifier is in protection mode the red LED will illuminate

11. Power Connections

Power connections. See Connections section for details on correct connections.

12. Fuses

Please ensure the following fuse rating is used when replacing fuses: 30 amp x 2

13. Speaker Terminal Output

For connection to the speakers. See Application section for wiring examples.

Applications - BlackBox Stereo 4

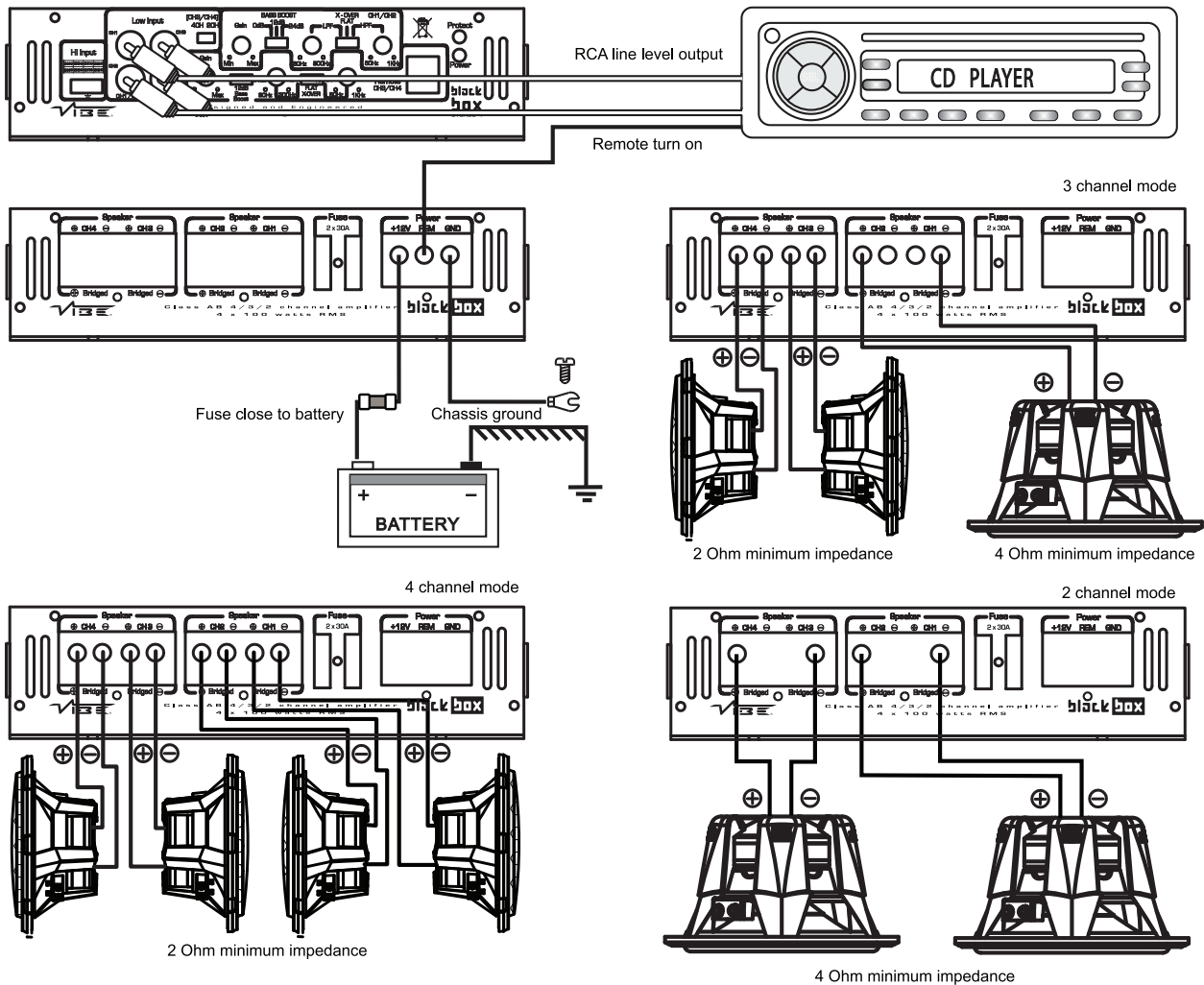

Connections and Controls - BlackBox BASS 1

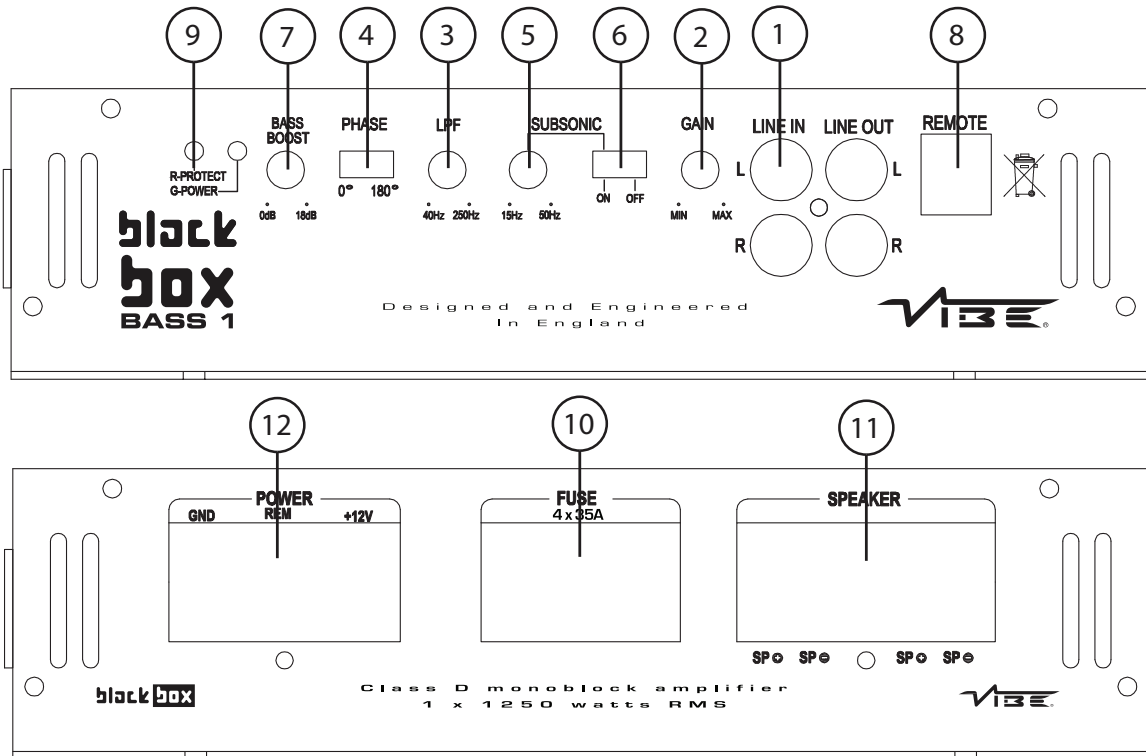

1. Low Level Input / Output

Low level input connection to any source (head unit) with a low level output. This is your RCA output from the source (headunit)

Low level output is a daisy chain RCA connection to allow easy addition of another amplifier.

2. Gain Control

Used to match the input signal of the source to the amplifier. See the setup section for more details.

3. Low Pass Filter Control

Low pass frequency control. The frequency ranges from 40 Hz to 250 Hz.

4. Phase Control

Can be used to alter the phase of the subwoofer from 0 - 180 degrees.

IE: The speaker output can be In phase or out of phase with the other speakers in the vehicle. For best results flick between the two settings to determine the best results.

5. Subsonic Filter Control

This is used to filter out unwanted amplifier output to the subwoofer. Effectively this will filter out all the frequencies up to the crossover point set with the control. The range is from 15 Hz to 50 Hz. Frequencies of 80 Hz and below cause the subwoofer to work hard, some subwoofers can easily be damaged when playing very low frequencies. Using the subsonic filter allows less distortion, delivers frequencies better suited to the subwoofer prolonging its life.

6. Subsonic Filter Switch

Used to turn the filter on or off.

7. Bass Boost Switch

To provide up to an extra +18 dB of bass boost at 45 Hz. Use this boost to increase bass output from the amplifier.

8. Bass Remote Input Jack

Use to plug in the remote bass controller.

9. Indicator LEDs

When the amplifier is operating correctly the LED will show as blue. When the amplifier is in protection mode the LED will show as red.

10. Fuses

Please ensure the following fuse rating is used when replacing fuses:
35 amp x 4

11. Speaker Terminal Output

For connection to the speakers. See Application section for wiring examples.

12. Power Connections

Power connections. See Connections section for details on correct connections.

Applications - BlackBox Stereo 4

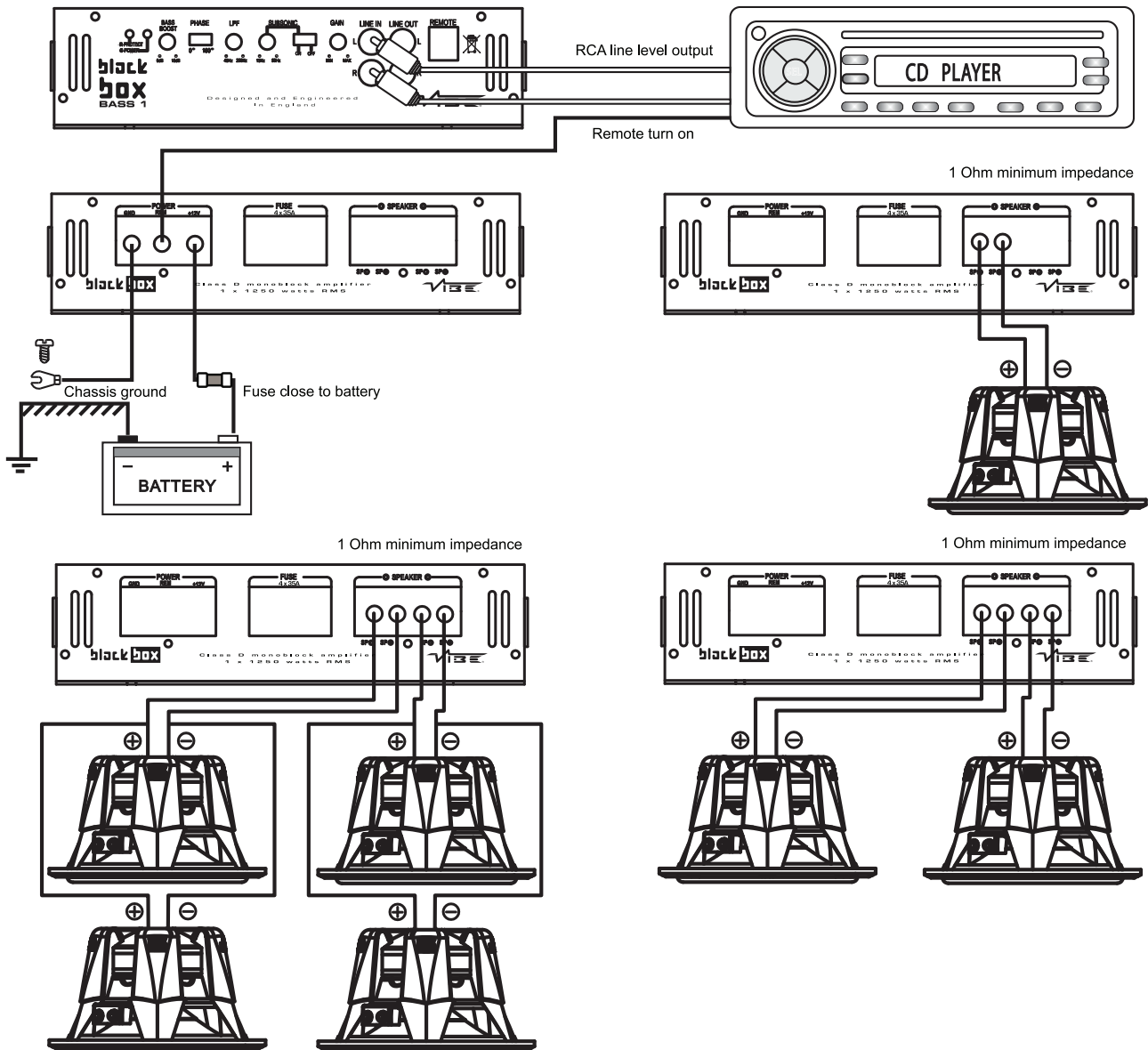

Set Up Section

To correctly set the gain control of the amplifier to match that of the source (headunit) use the following setup routine:

Turn the gain control to minimum on the amplifier.

Ensure the bass boost is set to 0 dB.

On the headunit set all crossovers (if applicable) to flat and both bass and treble to zero.

Turn up the source (headunit) to approx 3/4 volume.

Very slowly turn up the gain on the amplifier until distortion can be heard in any of the speakers or until the volume reaches an uncomfortable listening level when this is reached turn down the gain control slightly.

The gain control is now set.

The setting of the crossover will depend on what kind of speaker you are installing.

For a subwoofer it is recommended that the crossover is set to Low Pass and the frequency is set to match that of the speakers specifications, or your preferred frequency - this is usually about 60 - 120

For a pair of full range speakers it is recommended that the crossover is set to Flat. The two frequency controls will then have no effect on the amplifiers output and the speaker will receive a full range signal. However, using the high pass crossovers will allow more control of your speakers. By removing the bass (low frequencies) the speakers can perform at higher volumes with less distortion.

Note: The smaller the speaker, the less bass it can handle. Adjust the crossover to get the most and best sound from your speakers. The easiest way to do this is by limiting the amount of bass you feed them.

For a pair of speakers with a passive crossover it is recommended that the crossover is set to High Pass and the frequency is set to match that of the speakers specifications. - This is usually about 40 - 120Hz

Note:

By using the crossovers correctly you will not only lengthen the life of your speakers but you will also get better performance from them. To optimise your setup seek the advice of a professional installation engineer or visit your local VIBE audio dealer.

Troubleshooting

- Before removing the amplifier, refer to the list below and follow the suggested procedures.
- Always test the speakers and confirm that they are wired correctly first.
- If in any doubt get help from a qualified auto electrician.

Amplifier Will Not Power Up

- ✓ Check for good ground connections. Ensure Ground cable is connected directly to bare metal and not a painted surface.
- ✓ Using a multimeter check that remote terminal has at least 7V DC.
- ✓ Using a multimeter check that there is battery voltage of at least 10.5v DC on the positive terminal.
- ✓ Check all fuses.
- ✓ Check that the protection light is not illuminated. If it is lit, shut off the amplifier by disconnecting for thirty seconds and then turning it back on.

Protection LED Illuminates When Amplifier Is Powered Up

- ✓ Check for shorts on all speakers wires. (IE no speaker wires should be joined together and no speaker wires should be touching the cars chassis)
- The amplifier is designed to shut down automatically when the units temperature goes above 80 degrees. If the amplifier feels very hot then this may be the reason for the amplifier not starting.
- Remove the speaker wires and reset the amplifier. If the Protection LED still comes on then the amplifier is faulty. This damage may have been caused by either failure to follow these setup guidelines or abuse.

Amplifier Gets Very Hot

- ✓ Check the minimum speaker impedance for the amplifier is correct.
- ✓ Check for shorts on all speakers wires. (ie no speaker wires should be joined together and no speaker wires should be touching the cars chassis)
- ✓ Check that there is good airflow around the amplifier. In some applications an external fan may be required.

Blown Fuse(s)

- ✓ Check both positive supply and ground for shorts.
- ✓ Check that the positive wire is connected to the positive terminal on the amplifier.
- ✓ Check that the negative wire is connected to the ground terminal on the amplifier.
- ✓ Ensure that the correct rated fuse is fitted:

VIBE BlackBox Stereo 2 - 15 amp x 2,

VIBE BlackBox Stereo 4 - 30 amp x 2,

VIBE BlackBox Bass 1 - 35 amp x 4,

Distorted Sound

- ✓ Check the gain control is not set at too high If the speakers sound distorted turn down the gain until the sound is clear.
- ✓ Check that all crossover frequencies are correct. See Setup section for more details.
- ✓ Check for shorts on all speaker wires.
- ✓ Check all speakers are wired correctly. With the correct polarity being observed on each connection.

BlackBox stereo amplifiers

Specification	BlackBox stereo 2	BlackBox stereo 4
RMS Power @ 13.8v DC		
Power @ 4 Ohms stereo	2 x 100 WRMS	4 x 100 WRMS
Power @ 2 Ohms stereo	2 x 125 WRMS	4 x 125 WRMS
Power @ 4 Ohms bridged	1 x 250 WRMS	2 x 250 WRMS
Minimum speaker impedance	2 Ohm stereo / 4 Ohm bridged	2 Ohm stereo / 4 Ohm bridged
THD Distortion	0.1%	0.1%
IMD Distortion	0.1%	0.1%
Frequency Response	7Hz - 38 KHz	5Hz - 43 KHz
Input Sensitivity	250 mV - 5V	250 mV - 5V
Input Impedance	15K	15K
Signal to Noise Ratio	96 dB	88 dB
Channel Separation	-61 dB	-57 dB
Crossover Network		
Low pass filter	30 Hz – 300 Hz	30 Hz – 300 Hz
Bass Boost	0 dB - +24 Db	0 dB - +24 Db
High pass filter	50 Hz – 1KHz	50 Hz – 1KHz
Fuse rating	15A x 2	30A x 2
Size length x width x height	348mm x 224mm x 57 mm	448mm x 224mm x 57 mm

BlackBox bass amplifier

Specification	BlackBox bass 1
RMS power @ 13.8 vDC	
Power @ 4 ohms	1 x 650 WRMS
Power @ 2 Ohms	1 x 1000 WRMS
Power @ 1 Ohm	1 x 1250 WRMS
Minimum speaker impedance	1 ohm
THD Distortion	0.8 %
IMD Distortion	0.8 %
Input Sensitivity	250 mv - 5V
Input Impedance	15 K
Signal to Noise Ratio	95 dB
Crossover Network	
Low Pass Filter	40 Hz - 250 Hz
Bass Boost	0 dB -+18 dB
Subsonic Filter	15 Hz - 50 Hz
Fuse Rating	35 amp x 4
Size length x width x height	478 mm x 224mm x 57mm

Anti VIBE®

Sound Deadening Material

LESS RATTLE, MORE BASS

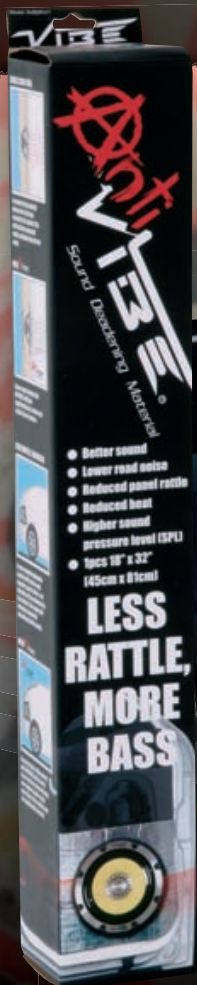

- Better sound
- Lower road noise
- Reduced panel rattle
- Reduced heat
- Higher sound pressure level (SPL)



Available at all VIBE DEALERS
OR VISIT
www.vibeaudio.co.uk





In order to protect your purchase and aid your warrantee please fill in the following form and keep it safe for your future reference:

Model Number:

Serial Number:

Purchased From:

Date of Purchase:

KEEP IT SAFE
Staple your receipt here:

Limited Warranty

All VIBE products carry a full twelve months warranty, valid from the date of the original receipt / proof of purchase. In order to validate this warranty, the warranty card should be returned to VIBE within seven days of the original purchase date. The original receipt and packaging should also be retained for this twelve month period.

If at any stage during the warranty period you have a problem with the product then it should be returned to the point of purchase, with proof of purchase in its original packaging, complete with no items missing.

If the store is unable to fix the product it may have to be returned to VIBE this process takes around 7 working days.

A full description of VIBE's warranty information can be found on our website:

www.vibeaudio.co.uk/warranty

A written version can also be obtained from
VIBE warranty Dept, PO BOX 11000, B75 7WG

Technical enquires
call 09067031420

call cost 50p per minute Call costs correct at date of publication (02/02/08) Hours of business 9.00am - 5.30pm all calls are recorded for training purposes MIDBASS Distribution PO Box 11000,B75 7WG

Copyright

All content included in this manual such as text, graphics, logos, icons, images and data, are the property of VIBE Technologies Limited (herein referred to as "VIBE", "us" or "we") and its affiliate or their content and technology providers, and are protected by United Kingdom and International copyright laws. All rights reserved.2008

All stylised representations of product names, or the abbreviations of product names, as logos are all trademarks of VIBE. Graphics and logos are trademarks or trade dress of VIBE Technologies Ltd or its subsidiaries.

VIBE's trademarks and trade dress may not be used in connection with any product or service that is not VIBE's, in any manner that is likely to cause confusion among customers or in any manner that disparages or discredits VIBE. All other trademarks not owned by VIBE or its subsidiaries that appear in this manual are the property of their respective owners, who may or may not be affiliated with, connected to, or sponsored by VIBE or its subsidiaries.

TO THE FULLEST EXTENT PERMITTED AT LAW, VIBE IS PROVIDING THIS MANUAL AND ITS CONTENT ON AN "AS IS" BASIS AND MAKES NO (AND EXPRESSLY DISCLAIMS ALL) REPRESENTATIONS OR WARRANTIES OF ANY KIND, EXPRESS OR IMPLIED, WITH RESPECT TO THIS MANUAL OR THE INFORMATION, CONTENT, MATERIALS OR PRODUCTS INCLUDED IN THIS MANUAL INCLUDING, WITHOUT LIMITATION, WARRANTIES OF MERCHANTABILITY AND FITNESS FOR A PARTICULAR PURPOSE. IN ADDITION, VIBE DOES NOT REPRESENT OR WARRANT THAT THE INFORMATION CONTAINED IN THIS MANUAL IS COMPLETE OR CURRENT, AND THAT ALL SPECIFICATIONS AND INFORMATION CONTAINED WITHIN THIS MANUAL ARE SUBJECT TO CHANGE WITHOUT NOTICE.

VIBE RECOMMEND CAUTION WHEN LISTENING TO MUSIC REPRODUCED THROUGH VIBE EQUIPMENT. VIBE EQUIPMENT IS CAPABLE OF PRODUCING SOUND AND SOUND PRESSURE LEVELS THAT CAN PERMANENTLY DAMAGE HEARING OF YOU AND THAT OF OTHERS. FOR SAFE AND ENJOYABLE LISTENING, THE SOUND SHOULD BE CLEAR WITHOUT DISTORTION AT A COMFORTABLE VOLUME.

BY USING ANY VIBE EQUIPMENT, YOU AGREE TO TAKE FULL RESPONSIBILITY FOR YOUR OWN SAFETY AND THE SAFETY OF OTHERS WHEN LISTENING TO MUSIC AT HIGH VOLUMES THROUGH EQUIPMENT YOU HAVE PURCHASED. USE OF ANY VIBE EQUIPMENT CONSTITUTES AGREEMENT TO THIS DISCLAIMER. Except as specifically stated in this manual, to the fullest extent permitted at law, neither VIBE nor any of its affiliates, directors, employees or other representatives will be liable for damages arising out of or in connection with the use of this manual or the information, content, materials or products included.

This is a comprehensive limitation of liability that applies to all damages of any kind, including (without limitation) compensatory, direct, indirect or consequential damages, loss of data, income or profit, loss of or damage to property and claims of third parties. For the avoidance of doubt, VIBE does not limit its liability for death or personal injury to the extent only that it arises as a result of negligence of VIBE, its affiliates, directors, employees or other representatives.



FLATBASS™ 13 SPK Bass speaker cable

There are many powerful bass amplifiers on today's market – the ever increasing power is putting huge strains on speaker wire – VIBE present a new breed of speaker cable specially developed for BASS applications – the VIBE FLATBASS speaker cable offers SolidCores™ that can handle and sustain considerably more power than conventional speaker cable.

Model: FlatBass 13 SPK – 13 gauge SolidCore™ flat BASS speaker cable



VIBE 140 amp circuit breaker

Big systems require big protection – The VIBE circuit breaker is rated at a massive 140 amps and offers critical protection to your system – if the system over powers or short circuits the breaker will cut in and save your equipment. No need to replace expensive fuses, system is reset via a simple switch – also offers safe and instant system shutdown.

Model: CB140 – 140 amp circuit breaker

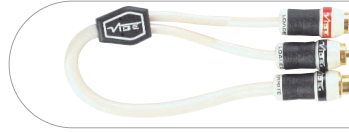

FLAT Y 2M / FLAT Y 2F RCA Y leads

Our professional quality full range DFC Y-interconnect guarantees a pure and strong signal. With a flat design and ferrite loaded gold plated plugs interference is greatly reduced. The FLAT-Y Interconnect is available in 1 male – 2 female FLAT Y 2F and 2 male – 1 female FLAT Y 2M configurations.

Model: FLAT Y 2f – 1 pair RCA Y lead 1 male to 2 female
Model: FLAT Y 2m – 1 pair RCA Y lead 2 male to 1 female



VIBE BC10 level controller

The VIBE BC10 gain level controller is a perfect addition to any subwoofer system, the BC10 allows the level of the amplifier to be controlled from the driver's seat giving the user easy adjustment of gain level. Particularly useful for adjusting the gain level for amplifiers controlling subwoofers. The BC10 controller is RCA input and output making it compatible with any system allowing gain level adjustment of any amplifier it is connected to. It can also be used with full range amplifiers.

Model: BC10 – RCA Gain level control



Slick level remote

A new addition to the Slick range of amplifiers is the Slick level control which allows level adjustment of the amplifier from the front of the car - Simply plug the supplied cable into the Slick remote level port on the end panel of the amplifier and remote gain control is yours, it is that easy.

Model: SLR1 – optional remote for use with all Slick amplifiers



VIBE PortPlug™

The VIBE PortPlug allows easy tuning of the VIBE CBR bass enclosures. The PortPlug™ is used to tightly seal the VIBE TurboPort™ in the enclosure to either create a sealed enclosure for better transient response or in the case of a multi ported enclosure re-tune the enclosure using only 1 PortPlug™

Model: PP25 – PortPlug™ for 2.5" TurboPort™
Model: PP30 – PortPlug™ for 3" TurboPort™



VIBE official Merchandise

MPS – VIBE polo shirt with embroidered VIBE logo on front and rear
MTS – VIBE T-shirt with small VIBE printed logo on front.
MCD – VIBE CD, containing exclusive VIBE bass tracks as featured on the Bass Tunnel and VIBE Dredd.
MCC – VIBE CD case, metallic silver CD case with VIBE logo.
VFL – VIBE fleece with embroidered logo on the front and large on back.
VTD – VIBE tax disc holder, stylish silver tax disc holder featuring VIBE logo.



VIBE SD4/5 subwoofer defender grill

The new VIBE subwoofer defender not only provides protection for your sub but also adds style with its metallic badge and black rubberised steel construction allow it to integrate perfectly with the VIBE EVO enclosures

Model: SD4 – sub grill fits both 10" and 12" subwoofers
Model: SD5 – sub grill fits 15" subwoofers



VIBE GB41 banana plug

The VIBE GB41 banana plugs are the easy and convenient way to quickly remove your bass enclosure without having to constantly re-thread your speaker cable into the box terminal, simply attach the speaker cable to the VIBE GB41 banana plug and you have a reliable quick release solution. Designed for optimum use with the TP-2 and GP-4 terminal, our professional gold plated 4mm banana plugs are polarity marked and feature rubber shrouds.

Model: GB41 – Gold Banana plug



VIBE DB6 non fused distribution block

The VIBE DB6 non fused distribution block is a professional non fused distribution block which gives easy connection for up to 5 amplifiers. The VIBE DB6 has 2 x 4AWG input and 4 x 8AWG outputs which can be used for power distribution or ground distribution giving a common grounding point for all system components eliminating the risk of ground loop interference.

Model: DB6 non fused distribution block



VIBE FD4 fused distribution block

The VIBE FD4 fused distribution block is a professional AGU fused distribution block which gives easy connection for up to 4 amplifiers. The VIBE FD4 has 1 x 4AWG input and 4 x 8AWG outputs each individually fused up to a maximum of 80 amps (AGU fuses available separately)

Model: FD4 – 4 way AGU fused distribution block, 1 x 4 gauge input 4 x 8 gauge outputs



VIBE CTO / CT4 compression fit ring terminal

The VIBE CT range of gold plated ring terminals are professional compression fit designed for maximum conductivity when connecting power cable to the vehicle battery. The VIBE RT compression fit terminals are the best way to connect heavy gauge power cable to the vehicles battery.

Model: CTO – 0 gauge compression fit ring terminal
Model: CT4 – 4 gauge compression fit ring terminal



VIBE RT4 / RT8 crimp on ring terminal

The professional range of VIBE RT gold plated ring terminals for connecting power cable to the vehicle battery. Packed in pairs and include red and black rubber over boots with are easy crimp design.

Model: RT8 – 1 pair of 8 gauge crimp on ring terminals with PVC overboots
Model: RT4 – 1 pair of 4 gauge crimp on ring terminals with PVC overboots



VIBE AGU30, AGU60, AGU80 fuses

The VIBE AGU fuse series are the perfect companion to the VIBE FD4 fused distribution block and the Active and stereo system wiring kits.

Model: AGU30 – 1 pair 30 amp AGU fuses to fit all AGU fuse holders
Model: AGU60 – 1 pair 60 amp AGU fuses to fit all AGU fuse holders
Model: AGU80 – 1 pair 80 AGU fuses to fit all AGU fuse holders

All Accessories are available direct, for next day delivery call 0870 765 8423 or visit www.vibeaudio.co.uk/shop (UK ONLY)

For more product info see www.vibeaudio.co.uk



The CriticalLink™ range of FLAT series cabling from VIBE

The VIBE CriticalLink range of cabling has been developed to achieve the critical link between source (headunit), amplifier and speakers - VIBE audio equipment is high quality, using anything less than the VIBE CriticalLink™ range of cables will severely compromise your equipment and will not allow it to perform to its maximum potential.

NOTE: Your audio equipment will only ever be as good as the cables you use to connect it. The link between your audio equipment is critical for a bigger cleaner sound.

VIBE cabling and interconnects can enhance your system power and sound quality by more than 20% over other brand cable.

All Accessories are available direct, for next day delivery call 0870 765 8423 or visit www.vibeaudio.co.uk/shop (UK ONLY)

For more product info see www.vibeaudio.co.uk



BASS SYSTEM KIT

The VIBE 3000watt BASS KIT is specifically designed to gain maximum output from high power Bass systems. Featuring the best BASS specific cables from the VIBE CriticalLink™ Range.

Contents of this Kit:

- FLATLINES™ 4AWG PWR Power and Ground cable
- FLATBASS™ RCA SolidCore™ Interconnect
- FLATBASS™ 13 SPK Bass speaker cable
- FLATLINES™ remote 18
- VIBE 140 amp circuit breaker

All cable is terminated with crimped terminal rings in place and accessory fitting kit

COMPATIBILITY

This kit is compatible with the majority of amplifiers on the market - VIBE recommends this kit for all VIBE BASS monoblock amplifiers new, current and old models.

Model: Bass Kit - Bass specific amplifier wiring kit



STEREO SYSTEM KIT

The VIBE 1500 watt STEREO KIT is specifically designed to gain maximum output from high power full range systems. Combining the best full range cables from the VIBE CriticalLink™ range.

Contents of this Kit:

- FLATLINES™ 8AWG PWR Power and Ground cable
- VIBE FLATSTEREO™ RCA - OFC high definition full range interconnect
- FLATLINES™ remote 18
- FLATSTEREO™ speaker cable
- AGU Fuse Holder

All cable is terminated with crimped terminal rings in place and accessory fitting kit

COMPATIBILITY

This kit is compatible with the majority of amplifiers on the market - VIBE recommends this kit for all VIBE full range STEREO amplifiers new, current and old models.

Model: Stereo Kit - full range stereo amplifier wiring kit



ACTIVE SYSTEM KIT

The VIBE 1500watt ACTIVE BASS KIT is specifically designed to gain maximum output from high power Active Bass systems (Bass Boxes). Featuring BASS specific components from the VIBE CriticalLink™ range.

Contents of this Kit:

- FLATLINES™ 8AWG PWR Power and Ground cable
- FLATBASS™ RCA SolidCore™ Interconnect
- FLATLINES™ remote 18
- AGU Fuse Holder
- FastPlug™

All cable is terminated with crimped terminal rings in place and accessory fitting kit

COMPATIBILITY

This kit is compatible with the majority of amplifiers on the market - VIBE recommends this kit for all VIBE active bass enclosures new, current and old models.

Model: Active Kit - Bass specific active enclosure wiring kit



PC15
1.5 farad
power capacitor

The VIBE 1.5 farad power capacitor is a must for any high performance audio system. VIBE's 1.5 farad power capacitor bridges the gap between the vehicles battery and the amplifiers ensuring rapid smooth current flow resulting in louder tighter bass and clean crisp midrange and treble. The built in digital voltage display constantly and accurately displays the systems DC voltage. An all new VIBE power distribution block is built into the top of the capacitor to allow easy wiring into the system and also will allow 3 amplifiers to be wired directly to the capacitor for maximum current flow to the amplifiers.

Model: PC15



delta box

The Deltabox line driver is the ideal solution for those looking to install multiple amplifiers from a single RCA preout. Most people use RCA "Y" splitters for this task unaware of the signal degradation caused. The Deltabox not only divides the signal but also isolates and boosts the signal up to a maximum of 9 volts independently for each of the 3 output channels giving much cleaner sound and excellent signal to noise ratio. For SPL competition the Deltabox is an essential tool as each of the outputs can be split 4 times giving control of 12 amplifiers from a single gain enabling precise adjustment of the system without having to reset every amplifier individually. Additionally if your headunit has a weak preout or you wish to run multiple amps but only have one output the Deltabox™ is your ideal solution. **Model: DELTABOX**



FAST PLUG

The VIBE FastPlug™ (pat. pending), is a product long overdue. Designed and developed by VIBE Engineers the plug offers safe, fast removal of your active bass enclosure (bass box) or amplifier. You may wish to remove your system for security reasons, or for the full use of your boot space, whatever the reason the VIBE FastPlug makes it easy and safe.

The plug is a heavy duty connector that connects positive, negative and remote wires. It is made up of 2 parts - one end to connect to your equipment and the other to your power source - made from high quality ABS plastic the device is tough and hard wearing. **Model: FASTPLUG**



FLATLINES™ Power and Ground Cable

VIBE FlatLines™ power cable has been developed to maximise voltage transfer from battery to amplifier - The cable has 2 main lines running side by side which are made up of fine copper strands - This design makes the cable flat allowing us to make very slim heavy duty power cable which is highly flexible easing installation.

Available in: system kits, by the roll or by the metre

- Model: FLATLINES 8 PWR** - 8gauge red power cable
- Model: FLATLINES 8 GND** - 8gauge black power cable
- Model: FLATLINES 4 PWR** - 4gauge red power cable
- Model: FLATLINES 4 PWR** - 4gauge red power cable
- Model: FLATLINES 0 PWR** - 0gauge red power cable
- Model: FLATLINES 0 GND** - 0gauge black power cable



FLATSTEREO™ High Definition full range Interconnect

The VIBE FLATSTEREO RCA is an OFC high definition full range interconnect - delivering the fullest signal possible from source to amplifier - the cable make up has been developed to run flat with left and right cables running parallel both with individual screening but sharing an outer FLAT jacket easing installations.

Available in:

- Model: FlatStereo RCA 1m** - 1 metre full range interconnect
- Model: FlatStereo RCA 5m** - 5 metre full range interconnect



FLATBASS™ - SolidCore™ Bass interconnect

The VIBE FLATBASS™ interconnect has been specifically developed for use in BASS SYSTEMS - the cable make up has a unique super FLAT™ design easing installation - Its trick ingredient is oversized SolidCore™ OFC signal wires - allowing a heavier voltage to be passed down the cable. This is the central wire that carries the main signal from source to amplifier.

Available in:

- Model: FlatBass RCA 1m** - 1 metre BASS interconnect
- Model: FlatBass RCA 5m** - 5 metre BASS interconnect



FLATFLEX™ High Definition speaker cable

The delivery of power and signal to the speaker is the final CriticalLink™ in any audio system - VIBES FlatFlex OFC high definition speaker cable is produced from super fine OFC copper strands collectively picking up all the detail in your music - the multi strands are aligned in a row making the cable super FLAT™ which can be run invisibly under carpets.

Available in:

- Model: FlatFlex 16 SPK** - 16 gauge High definition flat, flexible speaker cable
- Model: FlatFlex 12 SPK** - 12 gauge High definition flat, flexible speaker cable