



Installation, User and Service Manual

High-efficiency wall-hung gas boiler

Quinta Ace
135
160
HMI T-control

Dear Customer,

Thank you very much for buying this appliance.

Please read through the manual carefully before using the product, and keep it in a safe place for later reference. In order to ensure continued safe and efficient operation we recommend that the product is serviced regularly. Our service and customer service organisation can assist with this.

We hope you enjoy years of problem-free operation with the product.

Contents

1	Safety	6
1.1	General safety instructions	6
1.2	Recommendations	8
1.3	Specific safety instructions	10
1.3.1	Additional guidelines	10
1.4	Liabilities	10
1.4.1	Manufacturer's liability	10
1.4.2	Installer's liability	10
1.4.3	User's liability	11
2	About this manual	12
2.1	General	12
2.2	Additional documentation	12
2.3	Symbols used	12
2.3.1	Symbols used in the manual	12
3	Technical specifications	13
3.1	Homologations	13
3.1.1	Certifications	13
3.1.2	Unit categories	13
3.1.3	Directives	13
3.1.4	Factory test	13
3.2	Technical data	13
3.3	Dimensions and connections	16
3.4	Electrical diagram	17
4	Description of the product	18
4.1	General description	18
4.2	Operating principle	18
4.2.1	Gas/air regulation	18
4.2.2	Combustion	18
4.2.3	Control system	18
4.2.4	Control	19
4.2.5	Regulating the water temperature	19
4.2.6	Protection against shortage of water	19
4.2.7	Water flow	19
4.2.8	Hydraulic pressure sensor	19
4.2.9	Air pressure differential switch	19
4.2.10	Circulating pump	20
4.2.11	Calorifier connection	20
4.2.12	Cascade system	20
4.3	Main components	20
4.4	Control panel description	21
4.4.1	Control panel components	21
4.4.2	Description of the main menu	21
4.5	Standard delivery	22
4.6	Accessories and options	23
5	Before installation	24
5.1	Installation regulations	24
5.2	Lifting instruction	24
5.3	Choice of the location	24
5.3.1	Type plate	24
5.3.2	Location of the boiler	25
5.4	Transport	25
5.5	Unpacking & initial preparation	26
6	Installation	27
6.1	General	27
6.2	Preparation	27
6.2.1	Positioning the boiler	27
6.3	Hydraulic connections	27
6.3.1	Flushing the system	27
6.3.2	Connecting the heating circuit	28

6.3.3	Connecting the expansion vessel	28
6.3.4	Connecting the condensate drain pipe	29
6.4	Gas connection	29
6.5	Air supply/flue gas connections	29
6.5.1	Classification	30
6.5.2	Material	31
6.5.3	Dimensions of flue gas outlet pipe	32
6.5.4	Length of the air and flue gas pipes	32
6.5.5	Additional guidelines	33
6.5.6	Specific air and flue gas applications	34
6.5.7	Connecting the flue gas outlet and air supply	34
6.6	Electrical connections	35
6.6.1	Recommendations	35
6.6.2	Control unit	35
6.6.3	Assembly of the control panel	36
6.6.4	Connecting the connection box	37
6.6.5	The CB-01 connection PCB	38
6.7	Connecting a PC/laptop	41
6.8	Filling the installation	41
6.8.1	Water quality and water treatment	41
6.8.2	Filling the siphon	41
6.8.3	Filling the system	42
7	Commissioning	43
7.1	General	43
7.2	Gas circuit	43
7.3	Hydraulic circuit	43
7.4	Electrical connections	43
7.5	Commissioning procedure	43
7.6	Gas settings	44
7.6.1	Adjusting to a different gas type	44
7.6.2	Checking/setting combustion	45
7.7	Final instructions	47
8	Operation	48
8.1	Use of the control panel	48
8.1.1	Description of the home screen	48
8.1.2	Description of the main menu	48
8.2	Shut-down	49
8.3	Frost protection	50
9	Settings	51
9.1	Changing the parameters	51
9.1.1	Accessing the installer level	51
9.2	List of parameters	51
9.2.1	CU-GH06c Control Unit settings	52
9.3	Reading out measured values	56
9.4	List of measured values	57
9.4.1	CU-GH06c Control Unit counters	57
9.4.2	CU-GH06c Control Unit signals	58
9.4.3	Status and sub-status	62
10	Maintenance	64
10.1	General	64
10.2	Maintenance message	64
10.2.1	Resetting the service messages	64
10.2.2	Starting a new service interval	65
10.3	Standard inspection and maintenance operations	65
10.3.1	Checking the water pressure	65
10.3.2	Checking the water quality	65
10.3.3	Checking the ionisation current	66
10.3.4	Checking the flue gas discharge/air supply connections	66
10.3.5	Checking the combustion	66
10.3.6	Checking the air pressure differential switch	67
10.3.7	Checking the automatic air vent	68
10.3.8	Checking the burner and cleaning the heat exchanger	69

10.3.9	Cleaning the condensate collector	69
10.3.10	Cleaning the siphon	70
10.4	Specific maintenance work	70
10.4.1	Replacing the ionisation/ignition electrode	71
10.4.2	Checking the non-return valve	71
10.4.3	Reassembling the boiler	72
11	Disposal	73
11.1	Disposal and recycling	73
12	Troubleshooting	74
12.1	Error codes	74
12.1.1	Display of error codes	74
12.1.2	Warning	74
12.1.3	Blocking	75
12.1.4	Locking	78
12.2	Error history	82
12.2.1	Reading out and clearing the error memory	82
13	Appendix	83
13.1	ErP information	83
13.1.1	Product fiche	83
13.2	EC declaration of conformity	83
13.3	Checklist for commissioning	83
13.4	Checklist for annual maintenance	84

1 Safety

1.1 General safety instructions

For the installer:



Danger

If you smell gas:

1. Do not use naked flames, do not smoke and do not operate electrical contacts or switches (doorbell, lighting, motor, lift etc).
2. Shut off the gas supply.
3. Open the windows.
4. Trace possible leaks and seal them off immediately.
5. If the leak is upstream of the gas meter, notify the gas company.



Danger

If you smell flue gases:

1. Switch the boiler off.
2. Open the windows.
3. Trace possible leaks and seal them off immediately.



Caution

After maintenance or repair work, check the entire heating installation to ensure that there are no leaks.

For the end user:

**Danger**

If you smell gas:

1. Do not use naked flames, do not smoke and do not operate electrical contacts or switches (doorbell, lighting, motor, lift etc).
2. Shut off the gas supply.
3. Open the windows.
4. Report any leaks immediately.
5. Evacuate the property.
6. Contact a qualified installer.

**Danger**

If you smell flue gases:

1. Switch the boiler off.
2. Open the windows.
3. Report any leaks immediately.
4. Evacuate the property.
5. Contact a qualified installer.

**Warning**

Do not touch the flue gas pipes. Depending on the boiler settings, the temperature of the flue gas pipes can rise to over 60°C.

**Warning**

Do not touch radiators for long periods. Depending on the boiler settings, the temperature of the radiators can rise to over 60°C.

**Warning**

Be careful when using the domestic hot water. Depending on the boiler settings, the temperature of domestic hot water can rise to over 65°C.

**Warning**

The use of the boiler and the installation by you as the end-user must be limited to the operations described in this manual. All other actions may only be undertaken by a qualified installer.

**Warning**

The condensation drain must not be changed or sealed. If a condensate neutralisation system is used, the system must be cleaned regularly in accordance with the instructions provided by the manufacturer.



Caution

Ensure that the boiler is regularly serviced. Contact a qualified installer or arrange a maintenance contract for the servicing of the boiler.



Caution

Only genuine spare parts may be used.



Important

Regularly check for the presence of water and pressure in the heating installation.

1.2 Recommendations



Danger

This appliance can be used by children aged eight and above and people with a physical, sensory or mental disability, or with a lack of experience and knowledge, provided they are supervised and instructed in how to use the appliance in a safe manner and understand the associated dangers. Children must not be allowed to play with the appliance. Cleaning and user maintenance should not be carried out by children without adult supervision.



Warning

Installation and maintenance of the boiler must be carried out by a qualified installer in accordance with local and national regulations.



Warning

The installation and maintenance of the boiler must be undertaken by a qualified installer in accordance with the information in the supplied manual, doing otherwise may result in dangerous situations and/or bodily injury.



Warning

Removal and disposal of the boiler must be carried out by a qualified installer in accordance with local and national regulations.



Warning

If the mains lead is damaged, it must be replaced by the original manufacturer, the manufacturer's dealer or another suitably skilled person to prevent hazardous situations from arising.

**Warning**

Always disconnect the mains supply and close the main gas tap when working on the boiler.

**Warning**

Check the entire system for leaks after maintenance and servicing work.

**Danger**

For safety reasons, we recommend fitting smoke alarms at suitable places and a CO detector near the appliance.

**Caution**

- Make sure the boiler can be reached at all times.
- The boiler must be installed in a frost-free area.
- If the power cord is permanently connected, you must always install a main bipolar switch with an opening gap of at least 3 mm (BS EN 60335-1).
- Drain the boiler and central heating system if you are not going to use your home for a long time and there is a chance of frost.
- The frost protection does not work if the boiler is out of operation.
- The boiler protection only protects the boiler, not the system.
- Check the water pressure in the system regularly. If the water pressure is lower than 0.8 bar, the system must be topped up (recommended water pressure between 1.5 and 2.0 bar).

**Important**

Keep this document near to the boiler.

**Important**

Only remove the casing for maintenance and repair operations. Refit all panels when maintenance work and servicing are complete.

**Important**

Instruction and warning labels must never be removed or covered and must be clearly legible throughout the entire service life of the boiler. Damaged or illegible instructions and warning stickers must be replaced immediately.

**Important**

Modifications to the boiler require the written approval of **Remeha**.

1.3 Specific safety instructions

1.3.1 Additional guidelines

In addition to the legal requirements and guidelines, the supplementary guidelines in this manual must also be followed. Supplements or subsequent regulations and guidelines that are valid at the time of installation shall apply to all regulations and guidelines specified in this manual.

1.4 Liabilities

1.4.1 Manufacturer's liability

Our products are manufactured in compliance with the requirements of the various Directives applicable. They are therefore delivered with the CE marking and any documents necessary. In the interests of the quality of our products, we strive constantly to improve them. We therefore reserve the right to modify the specifications given in this document.

Our liability as manufacturer may not be invoked in the following cases:

- Failure to abide by the instructions on installing and maintaining the appliance.
- Failure to abide by the instructions on using the appliance.
- Faulty or insufficient maintenance of the appliance.

1.4.2 Installer's liability

The installer is responsible for the installation and initial commissioning of the appliance. The installer must observe the following instructions:

- Read and follow the instructions given in the manuals provided with the appliance.
- Install the appliance in compliance with prevailing legislation and standards.
- Carry out initial commissioning and any checks necessary.
- Explain the installation to the user.

- If maintenance is necessary, warn the user of the obligation to check the appliance and keep it in good working order.
- Give all the instruction manuals to the user.

1.4.3 User's liability

To guarantee optimum operation of the system, you must abide by the following instructions:

- Read and follow the instructions given in the manuals provided with the appliance.
- Call on a qualified professional to carry out installation and initial commissioning.
- Get your installer to explain your installation to you.
- Have the required inspections and maintenance carried out by a qualified installer.
- Keep the instruction manuals in good condition close to the appliance.

2 About this manual

2.1 General

This manual describes the installation, use and maintenance of the Quinta Ace boiler. This manual is part of all the documentation supplied with the boiler.

2.2 Additional documentation

The following documentation is available in addition to this manual:

- Installation and user manual for control panel
- Water quality instructions

2.3 Symbols used

2.3.1 Symbols used in the manual

This manual uses various danger levels to draw attention to special instructions. We do this to improve user safety, to prevent problems and to guarantee correct operation of the appliance.

**Danger**

Risk of dangerous situations that may result in serious personal injury.

**Danger of electric shock**

Risk of electric shock.

**Warning**

Risk of dangerous situations that may result in minor personal injury.

**Caution**

Risk of material damage.

**Important**

Please note: important information.

**See**

Reference to other manuals or pages in this manual.

3 Technical specifications

3.1 Homologations

3.1.1 Certifications

Tab.1 Certifications

CE identification number	PIN 0063CQ3781
Class NO _x ⁽¹⁾	6
Type of flue gas connection	B _{23P} ⁽²⁾ C ₁₃ , C ₃₃ , C ₅₃
(1) EN 15502-1 (2) When installing a boiler with connection type B _{23P} , the IP rating of the boiler is lowered to IP20.	

3.1.2 Unit categories

Tab.2 Unit categories

Country	Category	Gas type	Connection pressure (mbar)
Great Britain	II _{2H3B/P}	G20 (H gas) G30/G31 (butane/propane)	20 30-50

3.1.3 Directives

In addition to the legal requirements and guidelines, the supplementary guidelines in this manual must also be followed.

Supplements or subsequent regulations and guidelines that are valid at the time of installation shall apply to all regulations and guidelines specified in this manual.





3.1.4 Factory test

Before leaving the factory, each boiler is optimally set and tested for:

- Electrical safety.
- Adjustment of O₂/CO₂.
- Water tightness.
- Gas tightness.
- Parameter setting.

3.2 Technical data

Tab.3 General

Quinta Ace			135	160
Nominal output (P _n) for central heating operation (80°C/60°C)	min. - max.  ⁽¹⁾	kW	31.5 - 128.1 128.1	31.5 - 152.1 152.1
Nominal output (P _n) for central heating operation (50°C/30°C)	min. - max.  ⁽¹⁾	kW	34.7 - 136.1 136.1	34.7 - 161.6 161.6
Nominal input (Q _{nh}) central heating operation (Hi) G20 (H gas)	min. - max.  ⁽¹⁾	kW	32.0 - 131.0 131.0	32.0 - 156.0 156.0
Nominal input (Q _{nh}) central heating operation (Hi) G31 (Propane)	min. - max.	kW	40.0 - 131.0	40.0 - 156.0
Nominal input (Q _{nh}) central heating operation (Hs) G20 (H gas)	min. - max.  ⁽¹⁾	kW	35.6 - 145.5 145.5	35.6 - 173.3 173.3

Quinta Ace			135	160
Nominal input (Q _{nh}) central heating operation (Hs) G31 (Propane)	min. - max.	kW	43.4 - 142.0	43.4 - 169.6
Full load central heating efficiency (Hi) (80/60 °C) (92/42/EEC)		%	97.8	97.5
Full load central heating efficiency (Hi) (50°C/30°C) (EN15502)		%	103.9	103.6
Part load central heating efficiency (Hi) (return temperature 60°C)		%	98.4	98.4
Part load central heating efficiency (92/42/EEC) (return temperature 30°C)		%	108.8	108.5
(1) Factory setting.				

Tab.4 Gas and flue gas data

Quinta Ace			135	160
Gas inlet pressure G20 (H gas)	min. - max.	mbar	17 - 25	17 - 25
Gas inlet pressure G31 (propane)	min. - max.	mbar	37 - 50	37 - 50
Gas consumption G20 (H gas) ⁽¹⁾	min. - max.	m ³ /h	3.4 - 13.9	3.4 - 16.5
Gas consumption G31 (propane) ⁽¹⁾	min. - max.	m ³ /h	-	1.4 - 6.3
BREEAM NO _x		mg/kWh	24	36
Flue gas mass flow rate	min. - max.	kg/h g/s	57 - 233 16 - 65	57 - 277 16 - 77
Flue gas temperature	min. - max.	°C	32 - 63	32 - 66
Maximum counter pressure		Pa	200	200
(1) Gas consumption based on lower heating value under standard conditions: T=288.15 K, p=1013.25 mbar. G20=34.02; G25.3=29.92; G25=29.25; G31=88.00MJ/m ³				

Tab.5 Central heating circuit data

Quinta Ace			135	160
Water content		l	17	17
Water operating pressure	min	bar	0.8	0.8
Water operating pressure (PMS)	max	bar	4.0	4.0
Water temperature	max	°C	110	110
Operating temperature	max	°C	90	90
Pressure drop secondary circuit (ΔT=20 K)		mbar	128	170

Tab.6 Electrical data

Quinta Ace			135	160
Supply voltage		V~	230	230
Power consumption – full load	max	W	199	275
Power consumption – low load	min	W	47	47
Power consumption – standby	min	W	5.3	5.3
Electrical protection index		IP	IPX1B	IPX1B
Fuses	Main	A A	6.3 1.6	6.3 1.6

Tab.7 Other data

Quinta Ace			135	160
Total weight (empty)		kg	147	147
Minimum mounting weight (without front panel)		kg	123	123
Average acoustic level at a distance of one metre from the boiler		dB(A)	59.5	59.5

Tab.8 Technical parameters

Quinta Ace			135	160
Condensing boiler			Yes	Yes
Low-temperature boiler ⁽¹⁾			No	No
B1 boiler			No	No
Cogeneration space heater			No	No
Combination heater			No	No
Rated heat output	P_{rated}	kW	128	152
Useful heat output at nominal heat output and high temperature operation ⁽²⁾	P_4	kW	128.0	152.1
Useful heat output at 30% of rated heat output and low temperature regime ⁽¹⁾	P_1	kW	42.7	50.8
Seasonal space heating energy efficiency	η_s	%	-	-
Useful efficiency at rated heat output and high temperature regime ⁽²⁾	η_4	%	88.1	87.8
Useful efficiency at 30% of rated heat output and low temperature regime ⁽¹⁾	η_1	%	98.0	97.8
Auxiliary electricity consumption				
Full load	el_{max}	kW	0.199	0.275
Part load	el_{min}	kW	0.047	0.047
Standby mode	P_{SB}	kW	0.005	0.005
Other items				
Standby heat loss	P_{stby}	kW	0.191	0.191
Ignition burner power consumption	P_{ign}	kW	-	-
Annual energy consumption	Q_{HE}	kWh GJ	-	-
Sound power level, indoors	L_{WA}	dB	68	68
Emissions of nitrogen oxides	NO_x	mg/kWh	29	35
(1) Low temperature means 30°C for condensing boilers, 37°C for low temperature boilers and 50°C (at heater inlet) for other heating appliances.				
(2) High temperature operation means 60°C return temperature at heater inlet and 80°C feed temperature at heater outlet.				

**See**



Refer to the back cover for contact details.

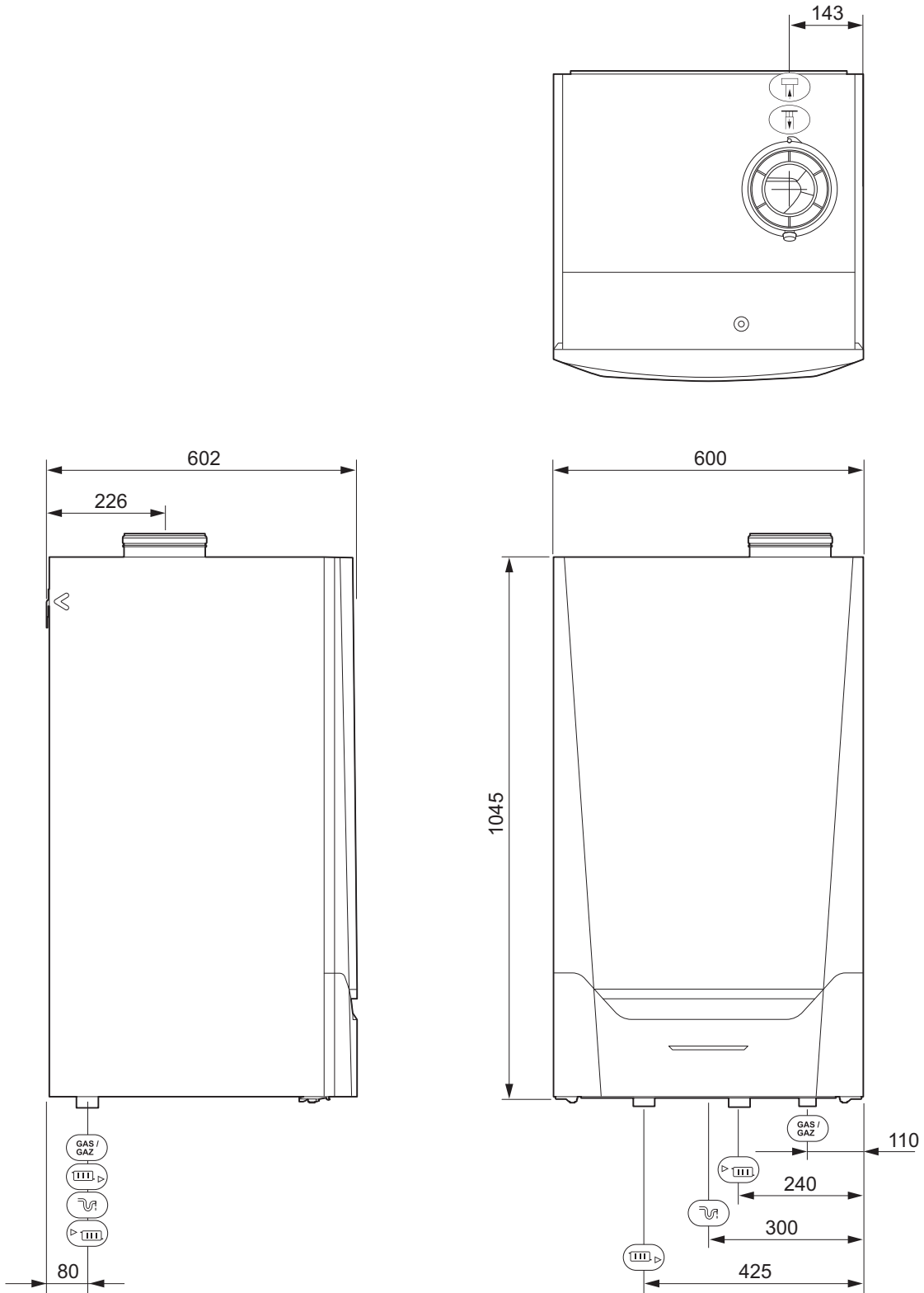

3.3 Dimensions and connections

Fig.1 Dimensions



AD-0000217-01

-  Flue gas outlet connection; Ø 100 mm
-  Air supply connection; Ø 150 mm
-  Siphon connection

-  CH flow connection; 1¼ inch male thread
-  CH return connection; 1¼ inch male thread
-  Gas connection; 1 inch male thread

3.4 Electrical diagram

Fig.2 Electrical diagram

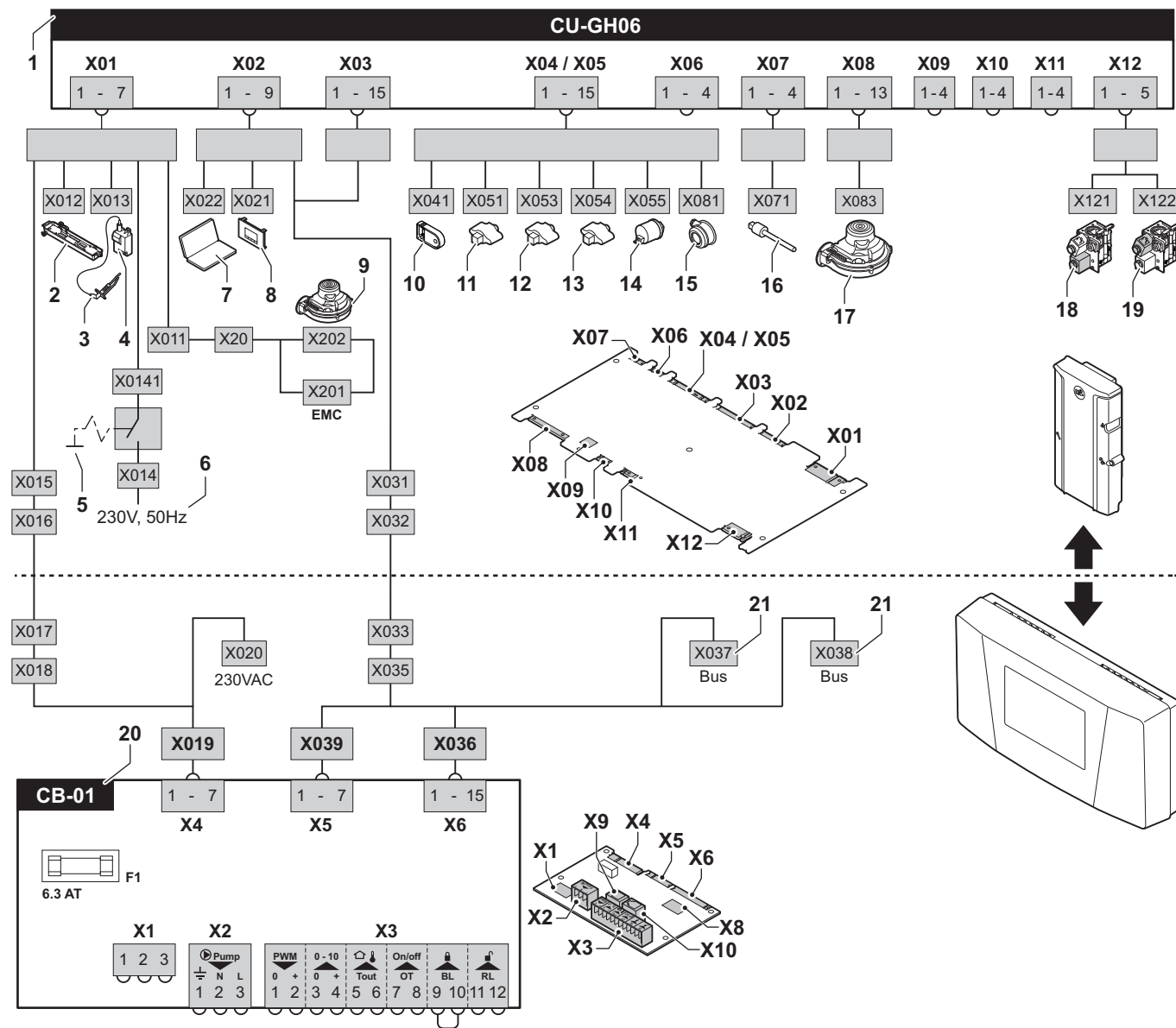

AD-0000669-06

- | | |
|---|--|
| 1 Control unit | 12 Heat exchanger sensor |
| 2 Lighting | 13 Return sensor |
| 3 Ignition pin | 14 Hydraulic pressure sensor |
| 4 Ignition transformer | 15 Air pressure differential switch |
| 5 On/off switch | 16 Flue gas sensor |
| 6 Power supply | 17 Fan control |
| 7 Service connector / computer connection | 18 Gas valve 1 |
| 8 Control panel | 19 Gas valve 2 |
| 9 Fan supply | 20 Standard PCB |
| 10 Storage parameter | 21 L-bus connections for additional PCBs |
| 11 Flow sensor | |

4 Description of the product

The Quinta Ace boiler is delivered with a combination of the control panel, control unit and extension PCB. The contents of this manual are based on the following software and navigation information:

Tab.9 Software and navigation information

	Name visible in display	Software version
Boiler Quinta Ace	FSB-WHB-HE-150-300	2.0
Control panel HMI T-control	MK3	1.29
PCB SCB-01	SCB-01	1.2

4.1 General description

The Quinta Ace boiler is a high-efficiency wall-hung gas boiler with the following properties:

- High-efficiency heating.
- Limited emissions of polluting substances.
- Ideal choice for cascade configurations.

4.2 Operating principle

4.2.1 Gas/air regulation

The boiler is equipped with a casing that also serves as an air box. The fan draws in the combustion air. The gas is injected into the venturi and mixed with the combustion air. The fan speed is controlled on the basis of the settings, the heat demand and the prevailing temperatures measured by the temperature sensors. The gas/air ratio control ensures an accurate mixture of the required amounts of gas and air. This provides optimum combustion over the entire heat input range. The gas/air mixture goes to the burner, where it is ignited by the ignition electrode.



Important

The combustion air supply is checked before each burner start, and at least once every 24 hours. During continuous operation (e.g. supplying process water), please note that the boiler control will reset every 24 hours.

4.2.2 Combustion

The burner heats the central heating water flowing through the heat exchanger. If the temperature of the flue gases is lower than the dew point (approx. 55°C), the water vapour condenses in the heat exchanger. The heat released during this condensation process (referred to as the latent or condensation heat) is also transferred to the central heating water. The cooled flue gases are discharged through the flue gas discharge pipe. The condensed water is discharged through a siphon.

4.2.3 Control system

The **e-Smart** electronic control system ensures that your heating system is smart and reliable. This means that the boiler responds practically to negative environmental influences (such as limited water flow and air flow problems). In the event of such influences, the boiler will not go into lockout mode, but in the first instance will modulate back. Depending on the nature of the circumstances, a warning, blocking or lock-out may occur. The boiler continues to supply heat provided the situation is not dangerous. With this control system, your boiler is also equipped for remote control and monitoring.

4.2.4 Control

- **On/off control**

The heat input varies between the minimum and the maximum values on the basis of the flow temperature set on the boiler. It is possible to connect a 2-wire on/off thermostat or a power stealing thermostat to the boiler.

- **Modulating control**

The heat input varies between the minimum and the maximum values on the basis of the flow temperature determined by the modulating controller. The boiler output can be modulated with an appropriate modulating controller.

- **Analogue control (0 - 10 V)**

The heat input varies between the minimum and the maximum values on the basis of the voltage present at the analogue input.

4.2.5 Regulating the water temperature

The boiler is fitted with an electronic temperature control with a flow and return temperature sensor. The flow temperature can be adjusted between 20°C and 90°C. The boiler modulates back when the set flow temperature is reached. The switch-off temperature is the set flow temperature + 5°C.

4.2.6 Protection against shortage of water

The boiler is fitted with low water level protection based on temperature measurements. By modulating back when the water flow threatens to become insufficient, the boiler remains operational as long as possible. The boiler issues a warning in the event of no or too little water. With an insufficient flow $\Delta T \geq 25$ K or too great an increase in the heat exchanger temperature sensor, the boiler goes into blocking mode.

4.2.7 Water flow

The modulating control of the boiler limits the maximum difference between the flow temperature and return temperature. In addition, a heat exchanger temperature sensor is mounted to monitor the minimum water flow. This limits the maximum increase in the heat exchanger temperature and monitors the maximum temperature difference between the flow, return and heat exchanger temperatures. As a result, the boiler is not affected by low water flow.

4.2.8 Hydraulic pressure sensor

The hydraulic pressure sensor records the water pressure in the boiler. Change the threshold value for the hydraulic pressure sensor using parameter **AP006**.



For more information, see

CU-GH06c Control Unit settings, page 52

Changing the parameters, page 51

4.2.9 Air pressure differential switch

The air pressure differential switch is a protection against a blocked trap or blocked air supply/flue gas outlet.

Before start-up and when the boiler is in operation, the air pressure differential switch **APS** measures the difference in pressure between the measuring points on the condensate collector p^+ and the air box p^- . If the pressure difference is greater than 6 mbar, then the boiler will lock out. After eliminating the cause of the breakdown, the boiler can be unlocked.

Fig.3 Water resistance

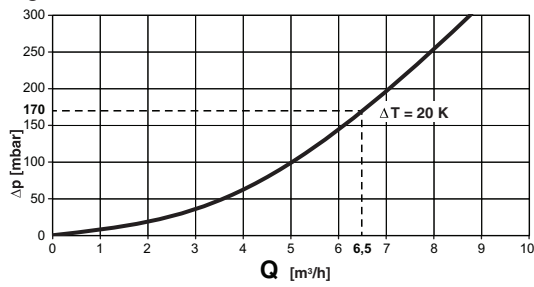

AD-0000857-02

4.2.10 Circulating pump

- ΔP Boiler resistance (mbar)
- Q Flow rate (m³/h)

The boiler is supplied without a pump. Take the boiler resistance and system resistance into account when selecting a pump.



See
Technical data, page 13.



Caution
Maximum power consumption may be 300 VA. Use an auxiliary relay for a pump with greater power.

4.2.11 Calorifier connection

A calorifier can be connected to the boiler. Our range includes various calorifiers.



Important
Contact us for more information.

4.2.12 Cascade system

The boiler is ideally suited for a cascade system. There are a number of standard solutions available.



Important
Contact us for more information.

4.3 Main components

Fig.4 Main components

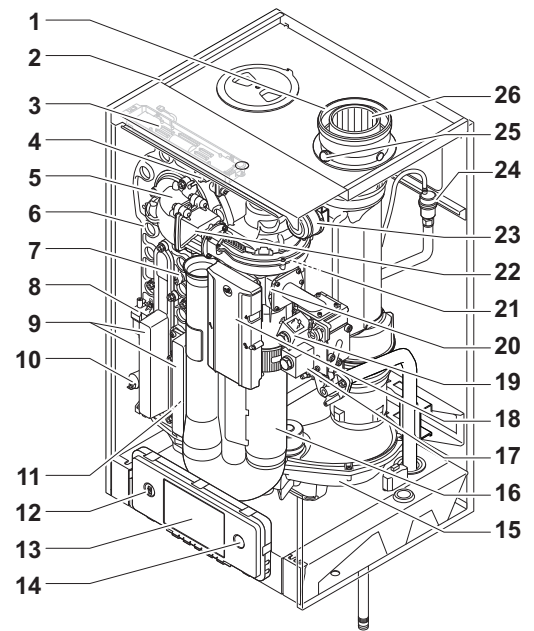

AD-0000218-02

- 1 Air supply/flue gas discharge
- 2 Casing/air box
- 3 Interior light
- 4 Flow sensor
- 5 Adapter
- 6 Heat exchanger
- 7 Temperature sensor for heat exchanger
- 8 Ignition transformer
- 9 Inspection hatch for heat exchanger (x2)
- 10 Water pressure sensor
- 11 Return sensor
- 12 PC/laptop connection point
- 13 Control panel
- 14 On/off switch
- 15 Condensate collector
- 16 Air inlet silencer
- 17 Gas pressure measuring point
- 18 Control unit (CU-GH)
- 19 Gas valve unit
- 20 Venturi
- 21 Fan
- 22 Non-return valve
- 23 Air pressure differential switch
- 24 Automatic air vent
- 25 Flue gas measuring point
- 26 Flue gas outlet

4.4 Control panel description

Fig.5 Control panel components

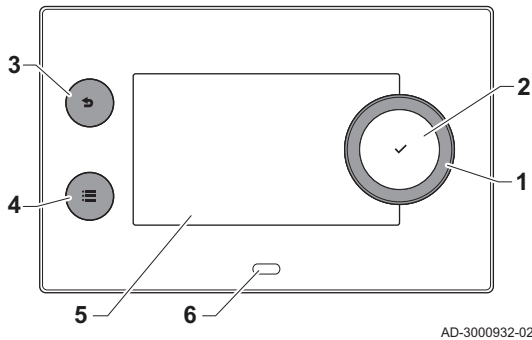

AD-3000932-02

4.4.1 Control panel components

- 1 Rotary knob to select a tile, menu or setting
- 2 Confirm button ✓ to confirm the selection
- 3 Back button ←:
 - **Short button press:** Return to the previous level or previous menu
 - **Long button press:** Return to home screen
- 4 Menu button ≡ to go to the main menu
- 5 Display
- 6 Status LED

4.4.2 Description of the main menu

You can navigate from any menu directly to the main menu by pressing the menu button ≡. The number of accessible menus depends on the access level (user or installer).

- A Date and time | Name of the screen (actual position in the menu)
- B Available menus
- C Brief explanation of the selected menu

Fig.6 Items in the main menu

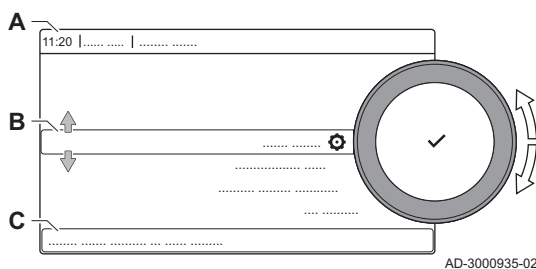

AD-3000935-02

Tab.10 Available menus for the user 👤

Description	Icon
System Settings	⚙️
Version Information	i

Tab.11 Available menus for the installer 👷



















Description	Icon
Installation Setup	👷
Commissioning Menu	👷
Advanced Service Menu	👷
Error History	👷
System Settings	⚙️
Version Information	i

■ Meaning of the icons in the display







Tab.12 Icons

Icon	Description
👤	User menu: user-level parameters can be configured.
👷	Installer menu: installer-level parameter can be configured.
i	Information menu: read out various current values.
⚙️	System settings: system parameters can be configured.
⊗	Error indicator.
🔥	Gas boiler indicator.
🚰	Domestic hot water tank is connected.
🏠	The outdoor temperature sensor is connected.
🔧	Boiler number in cascade system.
☀️	The solar calorifier is on and its heat level is displayed.

4 Description of the product

Icon	Description
	CH operation is enabled.
	CH operation is disabled.
	DHW operation is enabled.
	DHW operation is disabled.
	The burner is on.
	The burner is off.
	Burner output level (1 to 5 bars, with each bar representing 20% output).
	The pump is running.
	Three-way valve indicator.
	Display of the system water pressure.
	Chimney sweep mode is enabled (forced full load or low load for O ₂ /CO ₂ measurement).
	Energy-saving mode is enabled.
	DHW boost is enabled.
	Timer program is enabled: The room temperature is controlled by a timer program.
	Manual mode is enabled: The room temperature is set to a fixed setting.
	Temporary overwrite of the timer program is enabled: The room temperature is changed temporarily.
	The holiday program (including frost protection) is active: The room temperature is reduced during your holiday to save energy.
	Frost protection is enabled: Protect the boiler and installation from freezing in winter.
	Installer contact details are displayed or can be filled in.

Tab.13 Icons - Zones

Icon	Description
	All zones (groups) icon.
	Living room icon.
	Kitchen icon.
	Bedroom icon.
	Study icon.
	Cellar icon.

4.5 Standard delivery

Tab.14 The delivery includes 2 packages

One package with:	One package with:
<ul style="list-style-type: none"> The boiler, with mains lead 	<ul style="list-style-type: none"> Suspension bracket and fasteners for wall mounting Mounting template Siphon with condensate drain hose Connection box with connector for external connections, including: <ul style="list-style-type: none"> Standard control PCB CB-01 Expansion board SCB-10 Connection cables (230 V and 24 V) for connection between the connection box and boiler Sticker: This central heating unit is set for... Documentation



Important

This manual only deals with the standard scope of supply. For the installation or mounting of any accessories delivered with the boiler, refer to the corresponding mounting instructions.

4.6 Accessories and options

Various accessories can be obtained for the boiler.



Important

Contact us for more information.

5 Before installation

5.1 Installation regulations



Warning

The installer must be registered with Gas Safe and have the correct ACS qualifications.



Important

Practical guidelines - see the latest version.

5.2 Lifting instruction

The weight of the boiler exceeds the maximum lift weight for one person. We recommend the use of a lifting aid.

Fig.7 Lifting aids

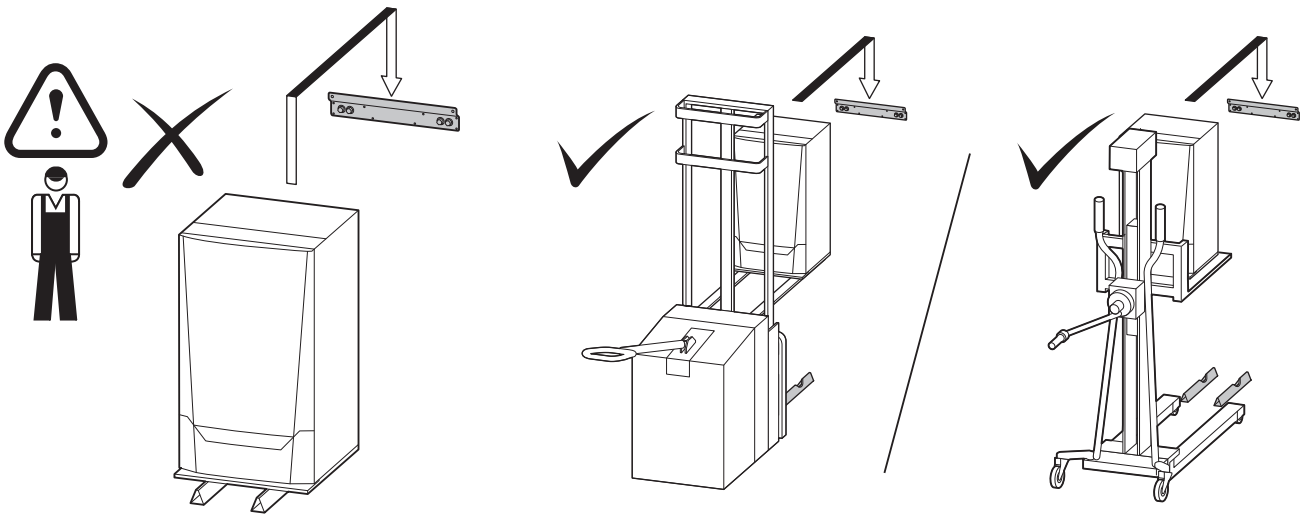

AD-0000138-03

5.3 Choice of the location

5.3.1 Type plate

Fig.8 Position of type plate

The type plate on top of the boiler features the boiler serial number and important boiler specifications, for example the model and unit category. The factory setting codes CN 1 and CN 2 are also stated on the type plate.

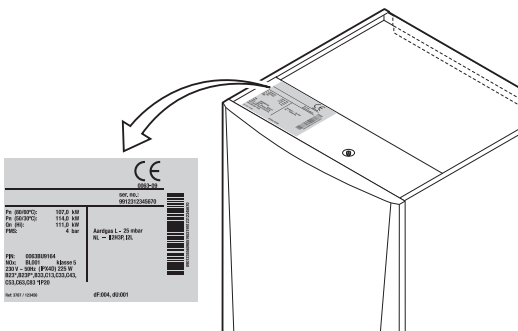

AD-0000103-01

Fig.9 Installation area

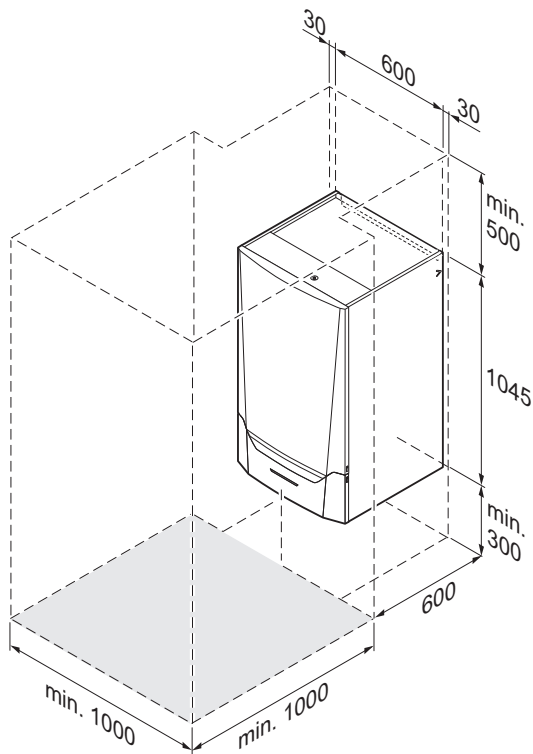

AD-0000104-03

5.3.2 Location of the boiler

- Use the guidelines and the required installation space as a basis for determining the correct place to install the boiler. When determining the correct installation space, take account of the permitted position of the flue gas discharge and/or air supply outlet.
- Ensure that there is sufficient space around the boiler for good access and ease of maintenance.



Danger

It is forbidden to store, even temporarily, combustible products and substances in the boiler or near the boiler.



Caution

- Mount the boiler on a strong and solid wall (at least half-brick brickwork with calcium silicate bricks). Build a reinforcing structure if necessary.
- The boiler must be installed in a frost-free area.
- The boiler must have an earthed electrical connection.
- A connection to the drain must be present for the condensate drain close to the boiler.
- The specified minimum space is required for standard maintenance work. For installation and extensive servicing work, there must be at least 1 m x 1 m of clear space in front of the boiler.



Caution

If the power cord is permanently connected, you must always install a main bipolar switch with an opening gap of at least 3 mm (BS EN 60335-1).

5.4 Transport

Fig.10 Boiler package

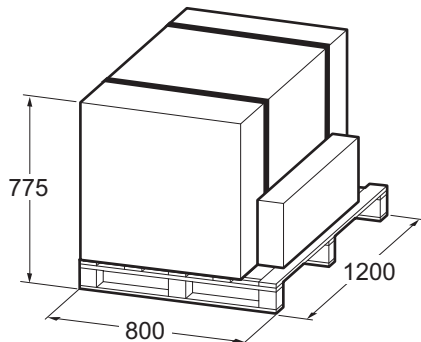

AD-0000136-03

The boiler is delivered on a pallet. The delivery includes 2 packages. One package with the boiler and one package with individual parts and technical documentation. Without the packaging, the boiler will fit through all standard doorways.



Important

Always transport the boiler as close to the installation site as possible before the packaging is removed.

5.5 Unpacking & initial preparation

Fig.11 Unpacking the boiler

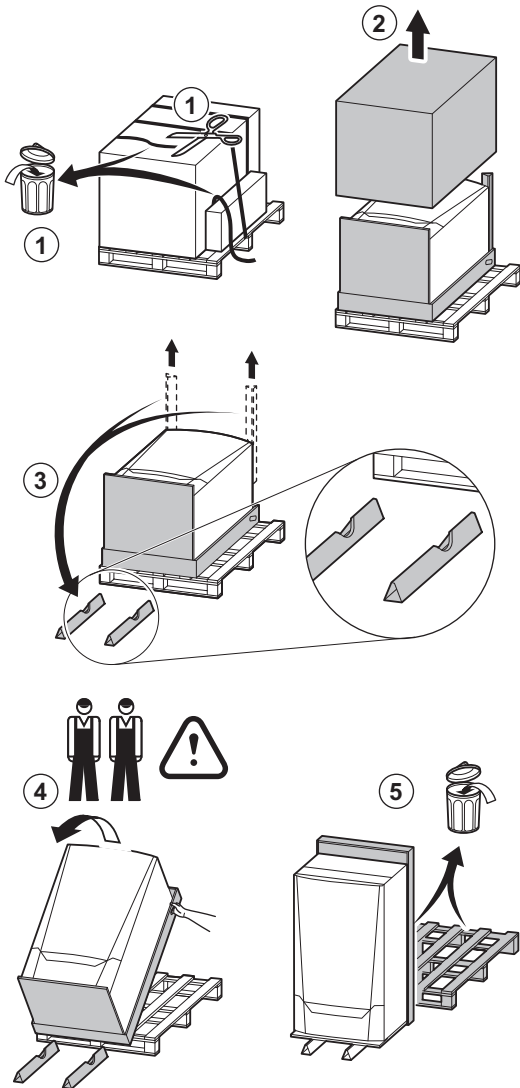

1. Cut the packaging straps and remove.
2. Remove the cardboard box.
3. Take the 2 floor stands out of the packaging and place them on the floor in front of the bottom of the boiler.
4. With 2 people, place the boiler upright on the floor stands.
5. Remove the pallet and the rest of the packaging.

i Important
The boiler can now be moved with a lifting aid.

AD-0000137-02

6 Installation

6.1 General



Warning

The boiler must be installed by a qualified installer in accordance with local and national regulations.

6.2 Preparation

Fig.12 Mounting the boiler

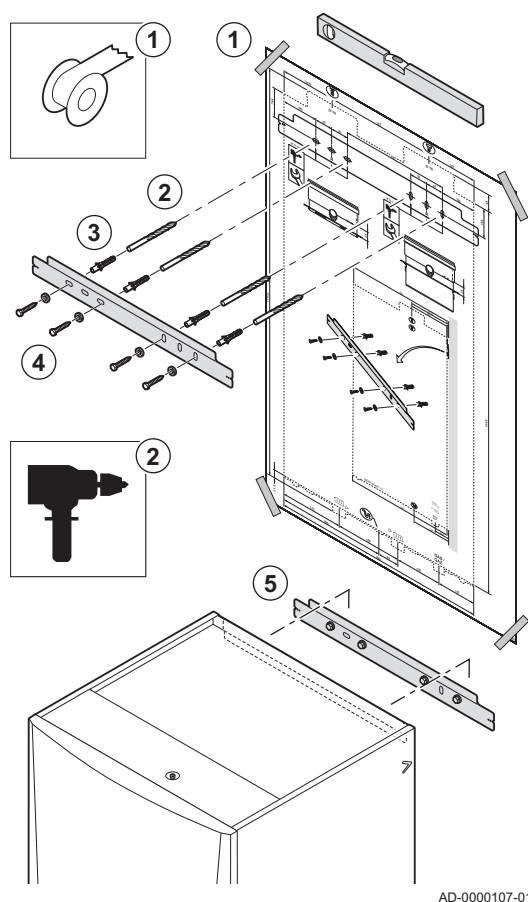

AD-0000107-01

6.3 Hydraulic connections

6.2.1 Positioning the boiler

The fitting bracket on the back of the casing can be used to mount the boiler directly on the suspension bracket.

The boiler is supplied with a mounting template.

1. Attach the mounting template of the boiler to the wall using adhesive tape.



Warning

- Use a level to check whether the mounting template is hanging perfectly horizontally.
- Protect the boiler against building dust and cover the flue gas outlet and air supply connection points. Only remove this cover to assemble the relevant connections.

2. Drill 4 holes of $\text{\O} 10 \text{ mm}$.
3. Fit the $\text{\O} 10 \text{ mm}$ plugs.
4. Attach the suspension bracket to the wall with the $\text{\O} 10 \text{ mm}$ bolts supplied.
5. Mount the boiler on the suspension bracket at the level of the arrows on the side of the boiler.



Warning

- The weight of the boiler exceeds the maximum lift weight for one person. Observe the applicable regulations. We recommend the use of a lifting aid. Please ensure all necessary care is taken when lifting the boiler on to the wall mounting bracket.
- The plugs supplied are only suitable for concrete. Select the correct plugs for installation on other materials.

6.3.1 Flushing the system

The installation must be cleaned and flushed in accordance with BS 7593 (2019) and BSRIA BG 33/2014.

Before a new boiler can be connected to a system, the entire system must be thoroughly cleaned by flushing it. The flushing will remove residue from the installation process (weld slag, fixing products etc.) and accumulations of dirt (silt, mud etc.)



Important

- Flush the heating system with a volume of water equivalent to at least three times the volume of the system.
- Flush the domestic hot water pipes with at least 20 times the volume of the pipes.



Important

Due to the presence of an aluminium heat exchanger, suitable chemicals and the correct use of these chemicals should be discussed with specialist water treatment companies.

6.3.2 Connecting the heating circuit

Fig.13 Connecting the CH flow

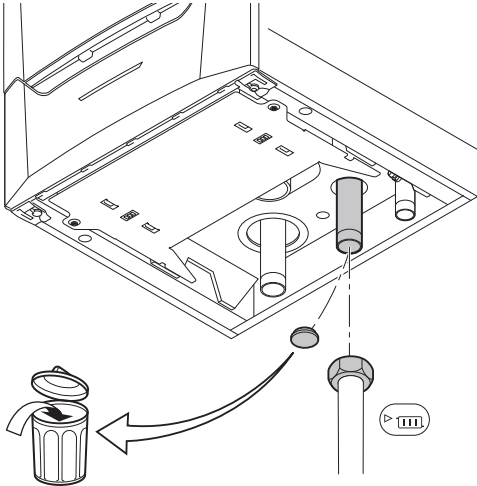

AD-0000108-01

1. Remove the dust cap from the CH flow connection at the bottom of the boiler.

Fig.14 Connecting the CH return

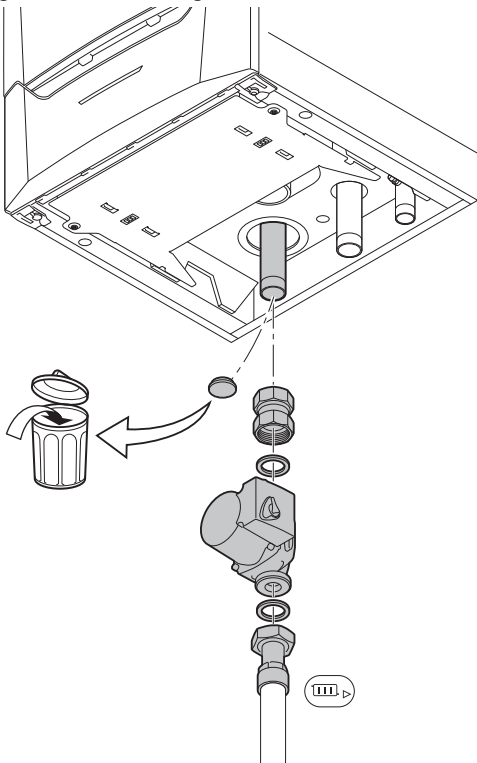

AD-0000109-01

2. Fit the outlet pipe for CH water to the CH flow connection.
3. Remove the dust cap from the CH return connection at the bottom of the boiler.
4. Fit the inlet pipe for CH water to the CH return connection.
5. For filling and tapping the boiler, install a filling and drain cock in the CH return pipe.
6. Install the system pump in the CH return pipe.



See

For the electrical connection of the system pump: Connecting the system pump, page 38



Important

Fit a service shut-off valve in the CH flow pipe and the CH return pipe to facilitate servicing work.



Caution

- When fitting service shut-off valves, position the filling and drain valve, the expansion vessel and the safety valve between the shut-off valve and the boiler.
- If using plastic pipes, follow the manufacturer's (connection) instructions.

6.3.3 Connecting the expansion vessel

1. Ensure that there is an expansion vessel with the correct volume and pre-charge.
2. Fit the expansion vessel on the central heating return pipe .

6.3.4 Connecting the condensate drain pipe

The siphon is supplied separately with the boiler as standard (including a flexible plastic drain hose and a transparent extension hose for the automatic air vent). Fit these parts under the boiler.

Fig.15 Connecting the condensate drain

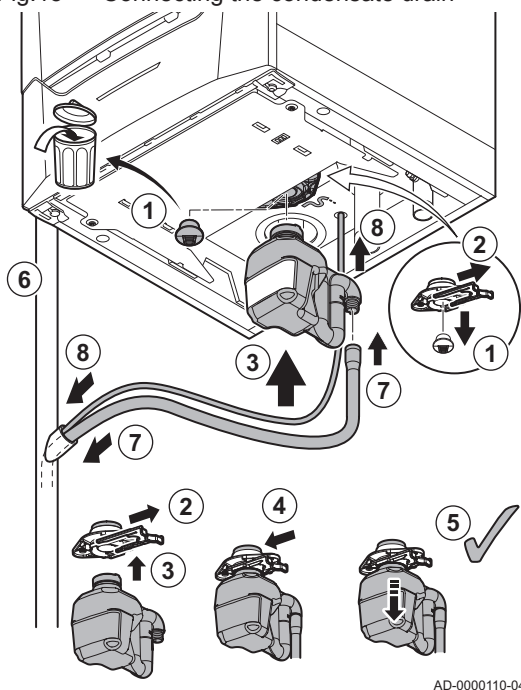

1. Remove the dust cap from the siphon connection  at the bottom of the boiler.
2. Pull the retainer clip of the siphon sideways.
3. Push the siphon firmly into the designated opening.
4. Push the retainer clip of the siphon forwards.
5. Check whether the siphon is firmly fitted in the boiler.
6. Fit a plastic drain pipe of \varnothing 32 mm or larger, terminating in the drain.
7. Attach the siphon hose supplied to the output of the siphon and insert the other end into the plastic drain pipe.
8. Push the transparent hose supplied into the connecting grommet of the automatic air vent and insert the other end into the plastic drain pipe.
9. Fit a stench-trap or siphon in the drain pipe.



Important

The air opening on the siphon prevents siphoning when the drain pipe is securely connected to the drain.



Danger

The siphon must always be filled with water. This prevents flue gases from entering the room.



Caution

- Never seal the condensate drain.
- The drain pipe must slope down at least 30 mm per metre, the maximum horizontal length is 5 metres.
- Condensed water must not be discharged into a gutter.

6.4 Gas connection



Warning

- Before starting work on the gas pipes, turn off the main gas tap. Before installing, check that the gas meter has sufficient capacity. Take into account the consumption of all appliances.
- Notify the local energy company if the gas meter has insufficient capacity.

Fig.16 Connecting the gas pipe

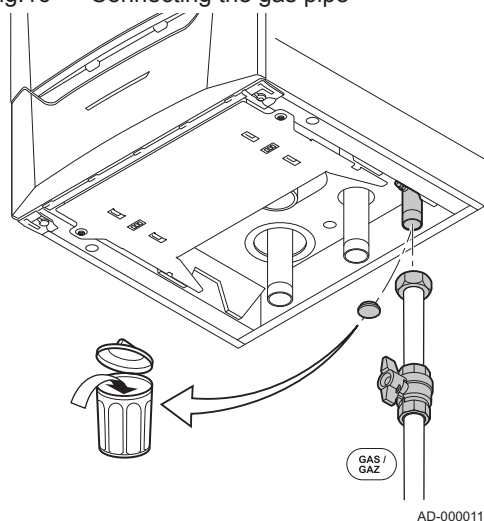

1. Remove the dust cap from the gas supply pipe $\frac{\text{GAS}}{\text{GAZ}}$ at the bottom of the boiler.
2. Fit the gas supply pipe.
3. Fit a gas tap in this pipe, directly underneath the boiler.
4. Fit the gas pipe to the gas tap.



Caution

- Remove dirt and dust from the gas pipe.
- Always perform welding work at a sufficient distance from the boiler.



Important

We recommend installing a gas filter to prevent clogging of the gas valve unit.

6.5 Air supply/flue gas connections

The boiler is suitable for the following types of flue gas connections:

6.5.1 Classification

i Important

- The installer is responsible ensuring that the right type of flue gas outlet system is used and that the diameter and length are correct.
- Always use connection materials, roof terminal and/or outside wall terminal supplied by the same manufacturer. Consult the manufacturer for compatibility details.

Tab.15 Type of flue gas connection: B_{23P}

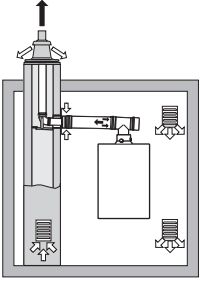
Principle	Description	Recommended manufacturers ⁽¹⁾
 <p>AD-3000924-01</p>	<p>Room-ventilated version</p> <ul style="list-style-type: none"> • Without down-draught diverter. • Flue gas discharge via the roof. • Air from the installation area. • The air supply opening of the boiler must stay open. • The installation area must be vented to ensure sufficient air supply. The vents must not be obstructed or shut off. • The IP rating of the boiler is lowered to IP20. 	<p>Connection material and roof terminal:</p> <ul style="list-style-type: none"> • Muelink & Grol
<p>(1) The material must also satisfy the material property requirements from the relevant chapter.</p>		

Tab.16 Type of flue gas connection: C₁₃

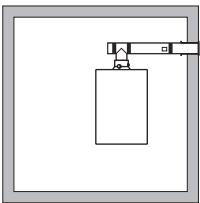
Principle	Description	Recommended manufacturers ⁽¹⁾
 <p>AD-3000926-01</p>	<p>Room-sealed version</p> <ul style="list-style-type: none"> • Discharge in the outside wall. • Air supply opening is in the same pressure zone as the discharge (e.g. a combined outside wall terminal). • Parallel wall terminal not permitted. 	<p>Outside wall terminal and connection material:</p> <ul style="list-style-type: none"> • Remeha, combined with connection material from Muelink & Grol • Muelink & Grol
<p>(1) The material must also satisfy the material property requirements from the relevant chapter.</p>		

Tab.17 Type of flue gas connection: C₃₃

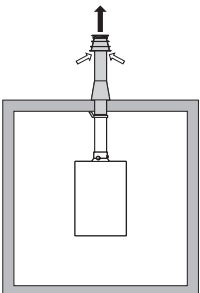
Principle	Description	Recommended manufacturers ⁽¹⁾
 <p>AD-3000927-01</p>	<p>Room-sealed version</p> <ul style="list-style-type: none"> • Flue gas discharge via the roof. • Air supply opening is in the same pressure zone as the discharge (e.g. a concentric roof terminal). 	<p>Roof terminal and connection material</p> <ul style="list-style-type: none"> • Muelink & Grol
<p>(1) The material must also satisfy the material property requirements from the relevant chapter.</p>		

Tab.18 Type of flue gas connection: C₅₃

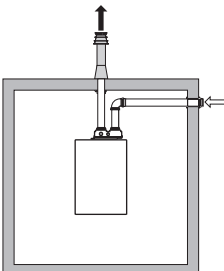
Principle	Description	Recommended manufacturers ⁽¹⁾
 <p style="text-align: center;">AD-3000929-02</p>	Connection in different pressure zones <ul style="list-style-type: none"> • Closed unit. • Separate air supply duct. • Separate flue gas discharge duct. • Discharging into various pressure areas. • The air supply and the flue gas outlet must not be placed on opposite walls. 	Connection material and roof terminal: <ul style="list-style-type: none"> • Muelink & Grol
(1) The material must also satisfy the material property requirements from the relevant chapter.		

6.5.2 Material

Use the string on the flue gas outlet material to check whether it is suitable for use on this appliance.

Fig.17 Sample string

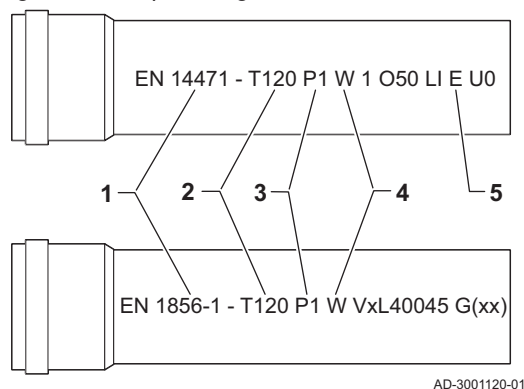

- 1 EN 14471 of EN 1856-1:** The material is CE approved according to this standard. For plastic this is EN 14471, For aluminium and stainless steel this is EN 1856-1.
- 2 T120:** The material has temperature class T120. A higher number is also allowed, but not lower.
- 3 P1:** The material falls into pressure class P1. H1 is also allowed.
- 4 W:** The material is suitable for draining condensation water (W='wet'). D is not allowed (D='dry').
- 5 E:** The material falls into fire resistance class E. Class A to D are also allowed, F is not allowed. Only applicable to plastic.



Warning

- The coupling and connection methods may vary depending on the manufacturer. It is not permitted to combine pipes, coupling and connection methods from different manufacturers. This also applies to roof feed-throughs and common channels.
- The materials used must comply with the prevailing regulations and standards.
- Please contact us to discuss using flexible flue gas outlet material.

Tab.19 Overview of material properties

Version	Flue gas outlet		Air supply	
	Material	Material properties	Material	Material properties
Single-wall, rigid	<ul style="list-style-type: none"> • Plastic⁽¹⁾ • Stainless steel⁽²⁾ • Thick-walled, aluminium⁽²⁾ 	<ul style="list-style-type: none"> • With CE marking • Temperature class T120 or higher • Condensate class W (wet) • Pressure class P1 or H1 • Fire resistance class E or better⁽³⁾ 	<ul style="list-style-type: none"> • Plastic • Stainless steel • Aluminium 	<ul style="list-style-type: none"> • With CE marking • Pressure class P1 or H1 • Fire resistance class E or better⁽³⁾
(1) according to EN 14471 (2) according to EN 1856 (3) according to EN 13501-1				

6.5.3 Dimensions of flue gas outlet pipe



Warning

The pipes connected to the flue gas adapter must satisfy the following dimension requirements.

- d_1 External dimensions of flue gas outlet pipe
- D_1 External dimensions of air supply pipe
- L_1 Length difference between flue gas outlet pipe and air supply pipe

Tab.20 Dimensions of pipe

	d_1 (min-max)	D_1 (min-max)	$L_1^{(1)}$ (min-max)
100/150 mm	99.3 - 100.3 mm	149 - 151 mm	0 - 15 mm

(1) Shorten the inner pipe if the length difference is too great.

Fig.18 Dimensions of concentric connection

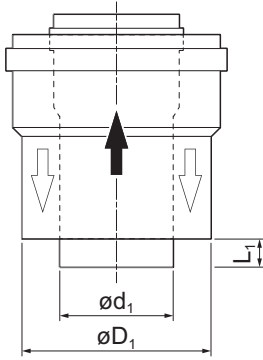

AD-3000962-01

6.5.4 Length of the air and flue gas pipes



Important

- When using bends, the maximum chimney length (L) must be shortened according to the reduction table.
- The boiler is also suitable for longer chimney lengths and diameters other than those specified in the tables. Contact us for more information.

■ **Room-ventilated model (B_{23P})**

- L** Length of the flue gas outlet channel to roof feed-through
- Connecting the flue gas outlet
- Connecting the air supply

Fig.19 Room-ventilated version

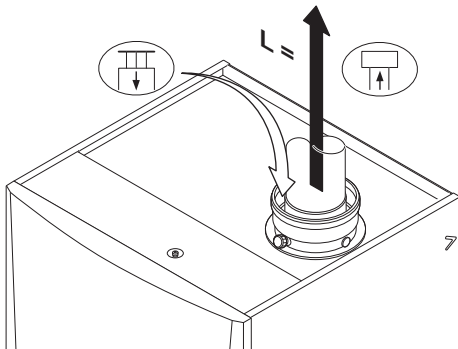

AD-0000220-01

With a room-ventilated version, the air supply opening stays open; only the flue gas outlet opening is connected. This will ensure that the boiler obtains the necessary combustion air directly from the installation area. Use adapters when using air supply and flue gas outlet pipes with diameters other than 150 mm.



Caution

- The air supply opening must stay open.
- The installation area must be equipped with the necessary air supply openings. These openings must not be obstructed or shut off.
- If the boiler is operated in a dusty environment (e.g. during the construction phase), use of an air inlet filter is necessary.

Tab.21 Maximum chimney length (L)

Diameter ⁽¹⁾	90 mm	100 mm	110 mm	130 mm	150 mm
Quinta Ace 135	8 m	12 m	23 m	40 m ⁽¹⁾	40 m ⁽¹⁾
Quinta Ace 160	5 m	8 m	15 m	37 m	40 m ⁽¹⁾

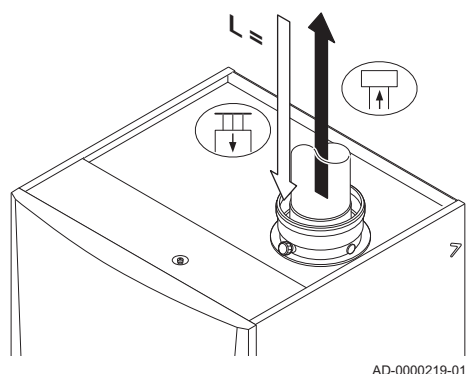

(1) With retention of the maximum flue length it is possible to apply an extra 5 times 90° or 10 times 45° elbows.

Fig.20 Room-sealed version



AD-0000219-01

■ Room-sealed model (C₁₃, C₃₃)

- L Length of the concentric flue gas outlet channel to roof feed-through
-  Connecting the flue gas outlet
-  Connecting the air supply

With a room-sealed version, both the flue gas outlet and the air supply openings are connected (concentrically). Use adapters when using air supply and flue gas outlet pipes with diameters other than 100/150 mm.

Tab.22 Maximum chimney length (L)

Diameter ⁽¹⁾	100/150 mm	130/200 mm	150/220 mm
Quinta Ace 135	5 m	20 m ⁽¹⁾	20 m ⁽¹⁾
Quinta Ace 160	1 m	12 m	20 m ⁽¹⁾



(1) Retaining the maximum chimney length, it is possible to use an extra 5 x 90° or 10 x 45° elbows.

■ Connection in different pressure areas (C₅₃)

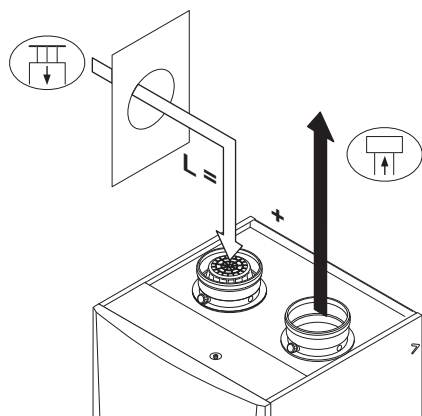
Fig.21 Different pressure zones



AD-0000114-01

- L Total length of the flue gas outlet and air supply duct
-  Connecting the flue gas outlet
-  Connecting the air supply

Combustion air supply and flue gas discharge are possible in different pressure areas and semi-CLV systems, with the exception of the coastal area. The maximum permitted height difference between the combustion air supply and the flue gas outlet is 36 m.

Tab.23 Maximum chimney length (L)

Diameter ⁽¹⁾	90 mm	100 mm	110 mm	130 mm	150 mm
Quinta Ace 135	-	6 m	15 m	40 m ⁽¹⁾	40 m ⁽¹⁾
Quinta Ace 160	-	-	9 m	27 m	40 m ⁽¹⁾

(1) With retention of the maximum flue length it is possible to apply an extra 5 times 90° or 10 times 45° elbows.

■ Reduction table

Tab.24 Pipe reduction for each element used (parallel)

Diameter	80 mm	90 mm	100 mm	110 mm	130 mm	150 mm	250 mm	300 mm
45° bend	1.2 m	1.3 m	1.4 m	1.5 m	1.0 m	1.2 m	2.0	2.4
90° bend	4.0 m	4.5 m	4.9 m	5.4 m	1.8 m	2.1 m	3.5	4.2

Tab.25 Pipe reduction for each element used (concentric)

Diameter	80/125 mm	100/150 mm	130/200 mm	150/220 mm
45° bend	1.0 m	1.0 m	1.5 m	1.5 m
90° bend	2.0 m	2.0 m	3.0 m	3.0 m

6.5.5 Additional guidelines

■ Installation

- For installing the flue gas outlet and air supply materials, refer to the instructions of the manufacturer of the relevant material. After installation, check at least all flue gas outlet and air supply parts for tightness.



Warning

If the flue gas outlet and air supply materials are not installed in accordance with the instructions (e.g. not leak-proof, not correctly bracketed), this can result in dangerous situations and/or physical injury.

- Make sure that the flue gas outlet pipe towards the boiler has a sufficient gradient (at least 50 mm per metre) and that there is a sufficient condensate collector and discharge (at least 1 m before the outlet of the boiler). The bends used must be larger than 90° to guarantee the gradient and a good seal on the lip rings.

■ **Condensation**

- Direct connection of the flue gas outlet to structural ducts is not permitted because of condensation.
- If condensate from a plastic or stainless steel pipe section can flow back to an aluminium part in the flue gas outlet, this condensate must be discharged via a collector before it reaches the aluminium.
- Newly installed aluminium flue gas pipes with longer lengths can produce relatively larger quantities of corrosion products. Check and clean the siphon more often in this case.



Important

Contact us for more information.

6.5.6 Specific air and flue gas applications



Important

If the boiler is used in a flue gas overpressure cascade, this must be stated on the sticker supplied: This central heating unit is set for... This sticker must be affixed on top of the boiler next to the type plate.

Contact us for more information.

6.5.7 Connecting the flue gas outlet and air supply

Fig.22 Connecting the flue gas outlet and air supply

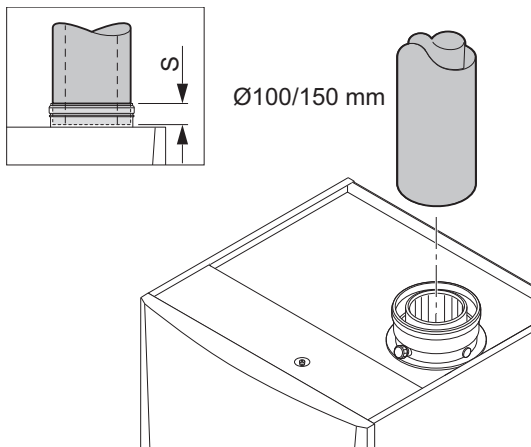

S insertion depth 50 mm

1. Fit the flue gas outlet pipe to the boiler.
2. Fit the subsequent flue gas outlet pipes and air supply pipes in accordance with the manufacturer's instructions.



Caution

- The pipes must be flue gas-tight and corrosion-resistant.
- The flue gas outlet pipe must be smooth and deburred.
- Connect the pipes so that they are stress-free.
- The pipes must not rest on the boiler.
- Fit the horizontal parts sloping down towards the boiler, with a slope of 50 mm per metre.

6.6 Electrical connections

6.6.1 Recommendations



Warning

- Electrical connections must always be made with the power supply disconnected and only by qualified installers.
- The boiler is completely pre-wired. Never change the internal connections of the control panel.
- Always connect the boiler to a well-earthed installation.

Establish the electrical connections in accordance with:

- The instructions of the current standards.
- The instructions of the wiring diagrams supplied with the boiler.
- The recommendations in this manual.
- Separate the sensor cables from the 230 V cables

6.6.2 Control unit

The table gives important connection values for the control unit.

Supply voltage	230 VAC/50 Hz
Main fuse value F1 (230 VAC)	6.3 AT
Fan	230 VAC



Danger of electric shock

The following components of the boiler are connected to a 230 V power supply:

- (Electrical connection for) circulating pump
- (Electrical connection for) gas combination block 230 RAC
- (Electrical connection of) fan
- The majority of components in the control unit
- Ignition transformer
- Power supply cable connection
- Various connections in the connection box

The boiler has a three-wire mains lead (lead length 1.5 m) and is suitable for a 230 VAC/50 Hz power supply with a phase/neutral/earth system. The boiler is not phase sensitive. The boiler is completely pre-wired.



Caution

- Always order a replacement mains lead from Remeha. The power supply cable should only be replaced by Remeha, or by an installer certified by Remeha.
- The switch must be easily accessible
- Use an isolating transformer for connection values other than those stated above.

The control panel and the connection box still need to be fitted. The PCBs are also placed in the connection box.

Fig.23 Connectors from the control unit CU-GH06 (front view)

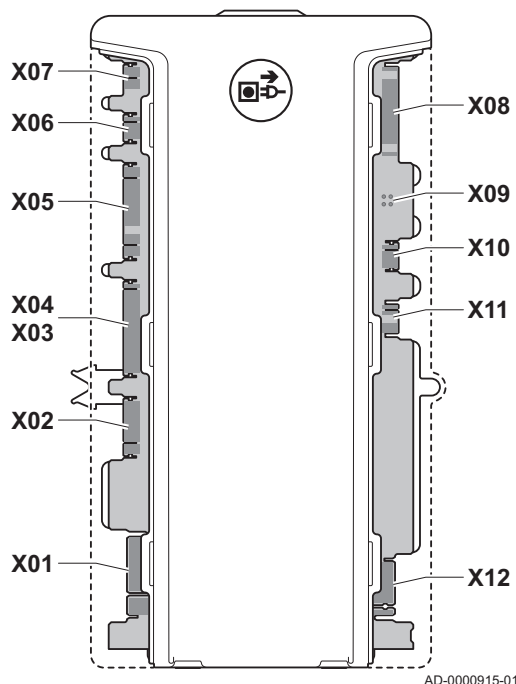
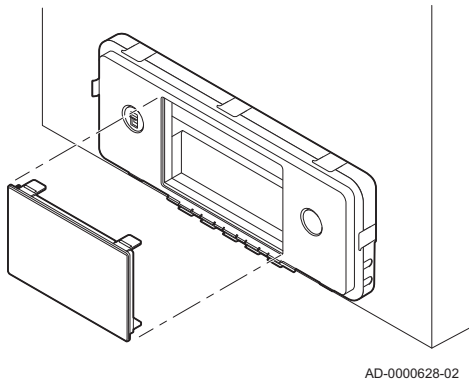

Fig.24 Control panel



6.6.3 Assembly of the control panel

The Quinta Ace boiler is supplied with a separate control panel. The control panel is mounted in the boiler. The cable in the box with connector **X021** must be slid onto the connector pin (5 pins, 24 V) of the PCB.

Fig.25 PCB

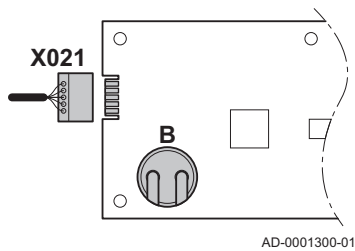

B Battery

There is also a back-up battery on the PCB for the internal clock. Check the battery voltage if the date and time are not displayed clearly.

Fig.26 Opening the connection box

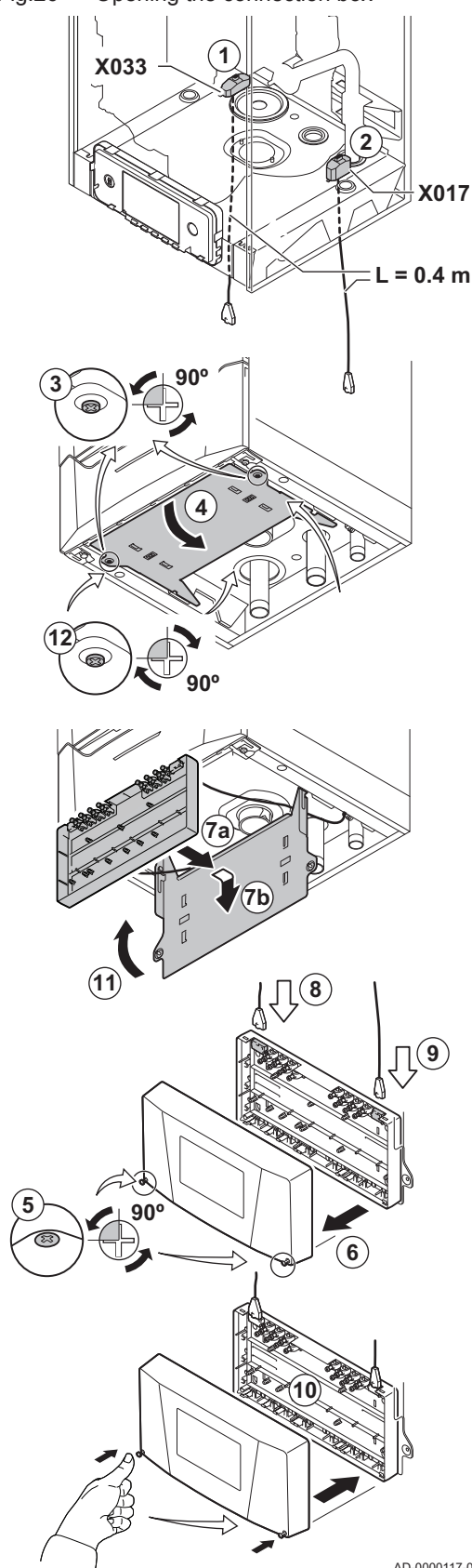

6.6.4 Connecting the connection box

The connection box is included with the delivery of the boiler as standard. Use the connection cables supplied to connect the connection box to the control unit. Proceed as follows:

1. Connect the supplied connection cable X033 to the connector underneath the boiler.
2. Connect the supplied connection cable X017 to the connector underneath the boiler.
3. Loosen the 2 screws of the connection box holder underneath the boiler by a quarter of a turn.
4. Push the holder slightly back and fold it down.
5. Loosen the 2 screws in the connection box by a quarter of a turn.
6. Open the cover of the connection box.
7. Slide and click the connection box into position on the connection box holder.
8. Connect the connection cable X033 with the connector in the connection box.
9. Connect the connection cable X017 with the connector in the connection box.
10. Now connect the desired external controllers to the other connectors. Proceed as follows:
 - 10.1. Lay the cable under the strain relief clip.
 - 10.2. Press the strain relief clip firmly in place.
 - 10.3. Close the connection box.
 - 10.4. Press the 2 screws in the connection box.
11. Lift the holder up and slide it forward into position.
12. Tighten the 2 screws of the connection box holder underneath the boiler by a quarter of a turn.



Important

The connection box can also be mounted on the wall. Use the screw holes on the back of the connection box. The supplied connection cables must not be extended. Special extension cables are available as an accessory.

AD-0000117-04

6.6.5 The CB-01 connection PCB

Fig.27 Connection PCB CB-01

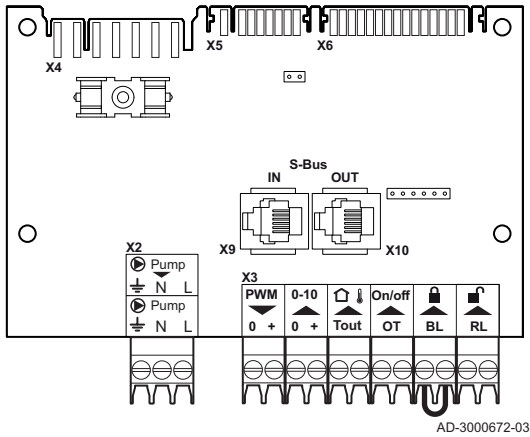

AD-3000672-03

The **CB-01** is placed in the control box. It provides easy access to all the standard connectors.

Fig.28 System pump

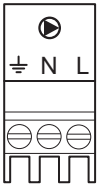

AD-3001306-01

■ Connecting the system pump

1. Connect a system pump to the **Pump** terminals of the connector.



Important

The maximum power consumption is 300 VA.

The function of the system pump can be changed using parameters **PP015**, **PP016** and **PP018**.



For more information, see

CU-GH06c Control Unit settings, page 52
Changing the parameters, page 51

■ Connecting a PWM system pump

A PWM system pump can be connected to the boiler and can be controlled in a modulating way from the boiler

1. Connect the PWM pump to the **PWM** terminals of the connector.



Important

Contact us for more information.

Fig.29 PWM system pump

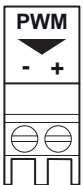

AD-3001307-01

■ Connecting an outdoor temperature sensor

An outdoor temperature sensor can be connected to the **Tout** connector.

1. Connect the two-wire cable to the **Tout** connector.

Use below mentioned sensors, or sensors with identical characteristics. Set parameter **AP056** to the installed outdoor temperature sensor type.

- AF60 = NTC 470 Ω/25°C

When an on/off thermostat is also connected, the boiler will control the temperature with the set point from the internal heating curve. **OpenTherm** controllers can also use the outdoor temperature sensor. In that case, the desired heating curve must be set on the controller.



For more information, see

CU-GH06c Control Unit settings, page 52
Changing the parameters, page 51

Fig.30 Tout connector

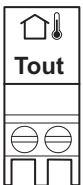

AD-4000006-02

Fig.31 Outdoor sensor

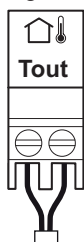

AD-3000973-02

Fig.32 Modulating thermostat



AD-3001310-01

Fig.33 Analogue input

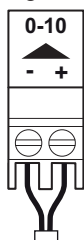

AD-3001304-01

Fig.34 Temperature regulation

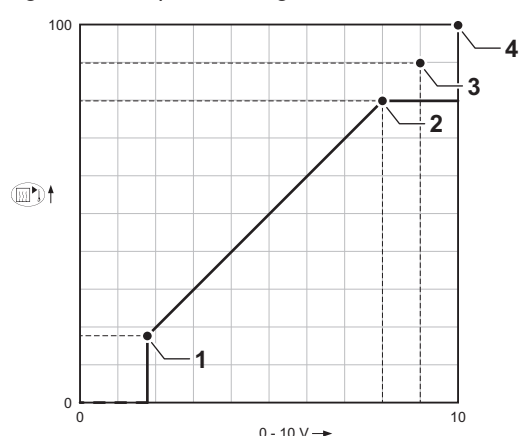

AD-0001156-03

■ Frost protection combined with outdoor sensor

The central heating system can also be protected against frost in combination with an outdoor sensor. The radiator valve in the frost-sensitive room must be open.

1. Connect the outdoor sensor to the terminals **Tout** of the connector.

The frost protection works as follows with an outdoor sensor:

- At outside temperatures below $-10\text{ }^{\circ}\text{C}$: the circulation pump switches on.
- At outside temperatures above $-10\text{ }^{\circ}\text{C}$: the circulation pump continues to run and then switches off.

■ Connecting the modulating regulator

OT OpenTherm thermostat

The boiler is fitted with an **OpenTherm** connection as standard. As a result, modulating **OpenTherm** thermostats (room-temperature, weather-compensated and cascade thermostats) can be connected without further modifications. The boiler is also suitable for OpenTherm Smart Power.

1. In the case of a room thermostat: install the thermostat in a reference room.
2. Connect the two-wire cable to the **On/Off OT** terminals of the connector. It does not matter which wire is connected to which cable clamp.

■ Analogue input

This input has two modes: control based on temperature or based on heat output. If this input is used, the OT communication from the boiler is ignored.

1. Connect the input signal to terminals **0-10** of the connector.

Change the mode of the analogue input using the parameter **EP014**.



For more information, see

CU-GH06c Control Unit settings, page 52

Changing the parameters, page 51

- Analogue temperature regulation ($^{\circ}\text{C}$)

- 1 Boiler on
- 2 Parameter **CP010**
- 3 Maximum flow temperature
- 4 Calculated value

The 0–10 V signal controls the boiler supply temperature. This control modulates on the basis of flow temperature. The output varies between the minimum and maximum value on the basis of the flow temperature set point calculated by the controller.

Tab.26 Temperature regulation

Input signal (V)	Temperature $^{\circ}\text{C}$	Description
0–1.5	0–15	Boiler off
1.5–1.8	15–18	Hysteresis
1.8–10	18–100	Desired temperature

- Analogue output-based control

The 0 - 10 V signal controls the boiler output. This control modulates on the basis of the heat output. The minimum output is linked to the boiler's modulation depth. The output varies between the minimum and maximum value on the basis of the value defined by the controller.

Tab.27 Control based on heat output

Input signal (V)	Heat output (%)	Description
0-2.0	0	Boiler off
2.0-2.2	0	Heat demand
2.0-10	0-100	Desired heat output

■ **Blocking input**

 **Caution**
Only suitable for potential-free contacts (dry contact).

 **Important**
First remove the bridge if this input is used.

The boiler has a blocking input. A potential-free contact can be connected to the **BL** terminals of the connector. If the contact is opened, the boiler will be blocked.

Change the function of the input using parameter **AP001**. This parameter has the following 3 configuration options:

- Complete blocking: no frost protection with the outdoor sensor and no boiler frost protection (pump does not start and burner does not start)
- Partial blocking: boiler frost protection (pump starts when the temperature of the heat exchanger is < 6°C and the burner starts when the temperature of the heat exchanger is < 3°C)
- Lock out: no frost protection with outdoor sensor and partial boiler frost protection (pump starts when the temperature of the heat exchanger is < 6°C, the burner does not start when the temperature of the heat exchanger is < 3°C).

 **For more information, see**
CU-GH06c Control Unit settings, page 52
Changing the parameters, page 51

■ **Release input**

 **Caution**
Only suitable for potential-free contacts (dry contact).

The boiler has a release input. A potential-free contact can be connected to the **RL** terminals of the connector.

- If the contact is closed during a heat demand, the boiler will be blocked immediately.
- If the contact is closed when there is no heat demand, the boiler will be blocked after a waiting time.

Change the waiting time of the input using parameter **AP008**.

 **For more information, see**
CU-GH06c Control Unit settings, page 52
Changing the parameters, page 51

Fig.35 Blocking input



AD-3000972-02

Fig.36 Release input

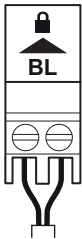
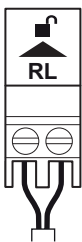

AD-3001303-01

6.7 Connecting a PC/laptop

Fig.37 Connecting an interface connector

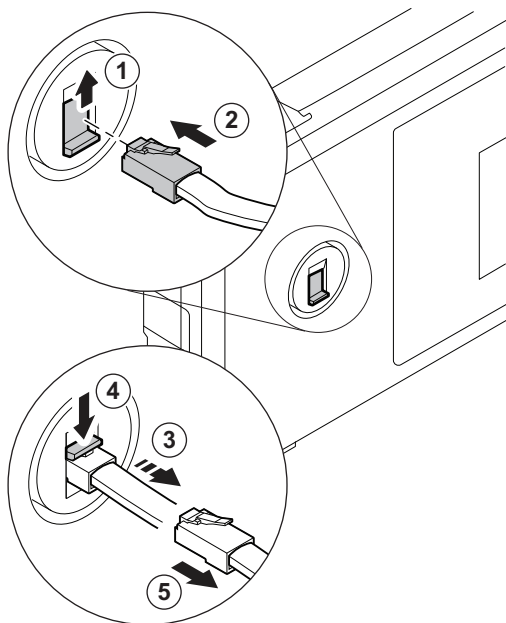

AD-0000311-01

There is a **Service** connector next to the control panel. A Recom interface can be used here to connect a:

- PC
- Laptop
- Smart Service Tool

Using the Recom service software, you can enter, change and read out various boiler settings.

Connecting and disconnecting an interface connector:

1. Move the Service connector slide upwards.
2. Push the interface connector into place. It should snap shut with a click.
⇒ The interface connector is connected.
3. Maintain slight tension on the interface connector
4. Push the slide downwards. The interface connector will now be released.
5. Pull the interface connector from the connector.
⇒ The interface connector is disconnected.

6.8 Filling the installation

6.8.1 Water quality and water treatment

The quality of the heating water must comply with the limit values in our **Water quality instructions**. The guidelines in these instructions must be followed at all times. In many cases, the boiler and central heating system can be filled with normal tap water and water treatment will not be necessary.

6.8.2 Filling the siphon

The siphon is supplied separately with the boiler as standard (including a flexible plastic drain hose and a transparent extension hose for the automatic air vent). Fit the siphon under the boiler.

Fig.38 Filling the siphon

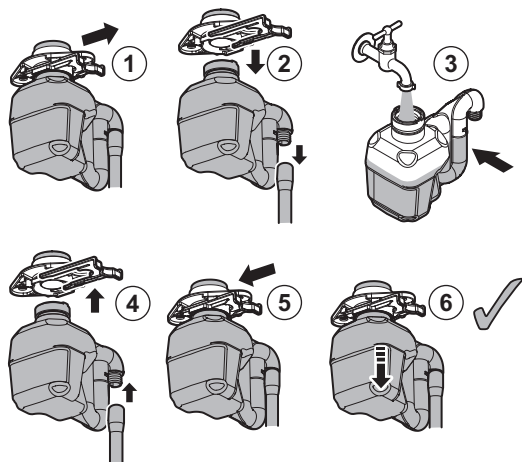

AD-0000231-03

1. Pull the retainer clip of the siphon backwards.
2. Carefully pull the siphon downwards.
3. Fill the siphon with water up to the mark.
4. Push the siphon firmly into the appropriate opening  underneath the boiler.
5. Push the retainer clip of the siphon forwards.
6. Check whether the siphon is firmly fitted in the boiler.



Danger

The siphon must always be sufficiently filled with water. This prevents flue gases from entering the room.

6.8.3 Filling the system



Important

In order to be able to read off the water pressure from the control panel, the boiler must be switched on. If the water pressure is too low, the boiler or the boiler pump will not start.

1. Fill the central heating system with clean tap water.



Important

The recommended water pressure is between 1.5 and 2 bar.

2. Check the water-side connections for tightness.

7 Commissioning

7.1 General

Follow the steps set out in the paragraphs below to put the boiler into operation.



Warning

Do not put the boiler into operation if the supplied gas is not in accordance with the approved gas types.

7.2 Gas circuit

Fig.39 Gas measuring point

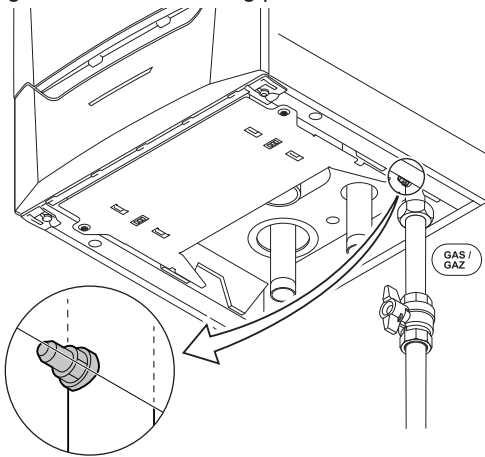

Warning

Ensure that the boiler is disconnected from the power supply.

1. Open the main gas tap.
2. Open the gas tap under the boiler.
3. Check the gas inlet pressure at the measuring point on the gas pipe.



Warning

For authorized gas pressures, see: Unit categories, page 13

4. Vent the gas supply pipe by unscrewing the measuring point.
5. Tighten the measuring point again when the pipe has been fully vented.
6. Check all connections for gas tightness. The test pressure may be a maximum of 60 mbar.

7.3 Hydraulic circuit

1. Check the siphon; it should be fully filled with clean water.
2. Check the water-side connections for tightness.

7.4 Electrical connections

1. Check the electrical connections.

7.5 Commissioning procedure



Warning

- Initial commissioning must be done by a qualified installer.
- If adapting to another type of gas, e.g. propane, the boiler must be adjusted before it is switched it on.



See

Adjusting to a different gas type, page 44

1. Open the main gas tap.
2. Open the boiler gas tap.
3. Switch the power on with the boiler's on/off switch.
 - ⇒ The start-up program will start and cannot be interrupted. During the program, all segments of the display are shown briefly.
4. Set the components (thermostats, control) so that heat is demanded.



Important

In the event of an error during the start-up, a message with the corresponding code is displayed. The meaning of the error codes can be found in the error table.

 **For more information, see**
Error codes, page 74

7.6 Gas settings

7.6.1 Adjusting to a different gas type

 **Warning**
Only a qualified engineer may carry out the following operations.

The factory setting of the boiler is for operation with the natural gas group G20 (H gas).

Tab.28 Factory settings G20 (H-gas)

Code	Display text	Description	Range	135	160
DP003	Abs. max fan DHW	Maximum fan speed on Domestic Hot Water	1000 - 8500 Rpm	5700	6700
GP007	Fan RPM Max CH	Maximum fan speed during Central Heating mode	1000 - 8500 Rpm	5700	6700
GP008	Fan RPM Min	Minimum fan speed during Central Heating + Domestic Hot Water mode	900 - 8500 Rpm	1900	1900
GP009	Fan RPM Start	Fan speed at appliance start	900 - 5000 Rpm	2200	2200

Fig.40 Installing gas diaphragm

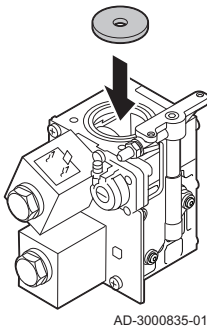

Before operating with a different type of gas, carry out the following steps:

1. Fit the gas diaphragm in the gas block. If the boiler is modified, for G30/G31 (butane/propane) :

Tab.29 Gas diaphragm for G30/G31 (butane/propane)

Gas diaphragm for G30/G31 (butane/propane)	Ø (mm)
Quinta Ace 135	-
Quinta Ace 160	9.0

2. Adjust the fan speed (if necessary) for the gas type used according to the table below. The setting can be changed with a parameter setting. If a boiler is not suitable for a certain gas type, it is indicated with "-" in the table.

Tab.30 Adjustment for gas type G30/G31 (butane/propane)

Code	Display text	Description	Range	135	160
DP003	Abs. max fan DHW	Maximum fan speed on Domestic Hot Water	1000 - 8500 Rpm	-	6400
GP007	Fan RPM Max CH	Maximum fan speed during Central Heating mode	1000 - 8500 Rpm	-	6400
GP008	Fan RPM Min	Minimum fan speed during Central Heating + Domestic Hot Water mode	900 - 8500 Rpm	-	2150
GP009	Fan RPM Start	Fan speed at appliance start	900 - 5000 Rpm	-	3000

3. Check the setting of the gas/air ratio.

 **See**
Checking/setting combustion, page 45

Fig.41 Flue gas measuring point



7.6.2 Checking/setting combustion

1. Unscrew the cap from the flue gas measuring point.
2. Insert the probe for the flue gas analyser into the measurement opening.

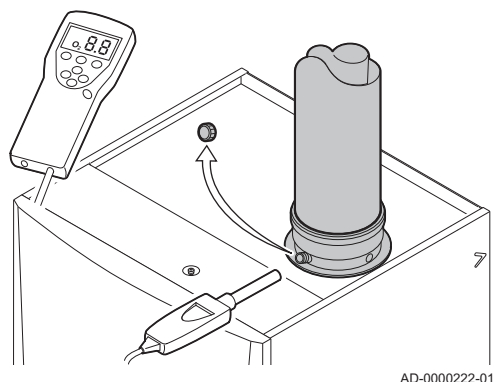

Warning

During measurement, seal the opening around the sensor fully.



Important

The flue gas analyser must have a minimum accuracy of $\pm 0.25\%$ O_2/CO_2 .



Important

The flue gas analyser must meet the requirements of BS 7927 or BS-EN 503793 and be calibrated according to the manufacturer's requirements.

3. Measure the percentage of O_2/CO_2 in the flue gases. Take measurements at full load and at part load.



Important

Measurements must be taken with the front casing off.

■ Performing the full load test

1. Select the tile [🔥].
⇒ The **Change load test mode** menu appears.
2. Select the test **Medium power**.

A Change load test mode

B Medium power

- ⇒ The full load test starts. The selected load test mode is shown in the menu and the icon 🔥 appears in the top right of the screen.
3. Check the load test settings and adjust if necessary.
⇒ Only the parameters shown in bold can be changed.

Fig.42 Full load test

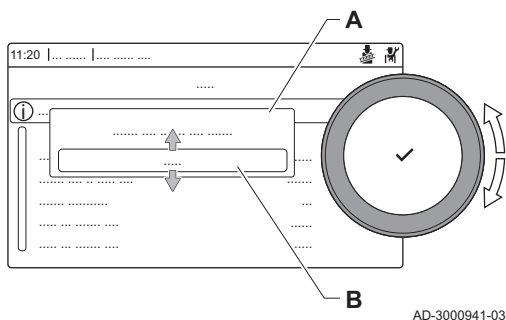

■ Checking/setting values for O_2/CO_2 at full load

1. Measure the percentage of O_2/CO_2 in the flue gases at full load.
2. Compare the measured value with the checking values in the table.

Tab.31 Checking/setting values for O_2/CO_2 at full load for G20 (H gas)

Values at full load for G20 (H gas)	O_2 (%) ⁽¹⁾	CO_2 (%) ⁽¹⁾
Quinta Ace 135	4.8 - 5.2 ⁽¹⁾	8.8 ⁽¹⁾ - 9.0
Quinta Ace 160	4.8 - 5.2 ⁽¹⁾	8.8 ⁽¹⁾ - 9.0
(1) Nominal value		

Tab.32 Checking/setting values for O_2/CO_2 at full load for G30/G31 (butane/propane)

Values at full load for G30/G31 (butane/propane)	O_2 (%) ⁽¹⁾	CO_2 (%) ⁽¹⁾
Quinta Ace 135	- - - ⁽¹⁾	- ⁽¹⁾ - -
Quinta Ace 160	5.1 - 5.4 ⁽¹⁾	10.2 ⁽¹⁾ - 10.4
(1) Nominal value		

Caution

- The O₂ values at full load must be lower than the O₂ values at low load.
- The CO₂ values at full load must be higher than the CO₂ values at low load.

Fig.43 Position of adjusting screw A

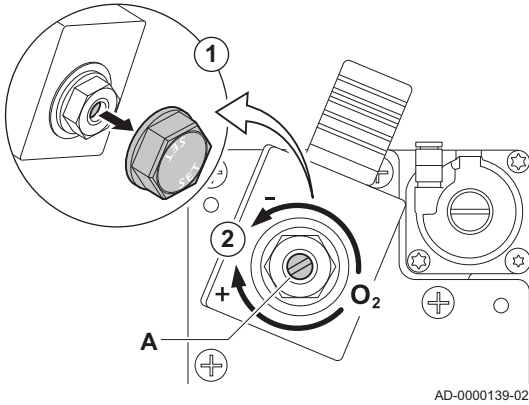

3. If the measured value is outside of the values given in the table, correct the gas/air ratio.
4. Using the adjusting screw **A**, set the percentage of O₂/CO₂ for the gas type being used to the nominal value. This should always be inside the highest and lowest setting limit.

Fig.44 Low load test

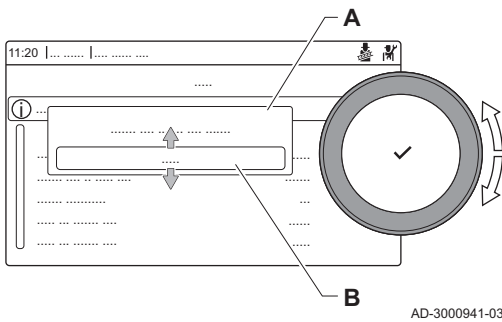

■ **Performing the low load test**

1. If the full load test is still running, press the ✓ button to change the load test mode.
2. If the full load test was finished, select the tile [👤] to restart the chimney sweep menu.

- A Change load test mode**
- B Low power**

3. Select the **Low power** test in the menu **Change load test mode**.
⇒ The low load test starts. The selected load test mode is shown in the menu and the icon 👤 appears in the top right of the screen.
4. Check the load test settings and adjust if necessary.
⇒ Only the parameters shown in bold can be changed.
5. End the low load test by pressing the ⏪ button.
⇒ The message **Running load test(s) stopped!** is displayed.

■ **Checking/setting values for O₂/CO₂ at part load**

1. Measure the percentage of O₂/CO₂ in the flue gases at part load.
2. Compare the measured value with the checking values in the table.

Tab.33 Checking/setting values for O₂/CO₂ at part load for G20 (H gas)

Values at part load for G20 (H gas)	O ₂ (%) ⁽¹⁾	CO ₂ (%) ⁽¹⁾
Quinta Ace 135	5.2 ⁽¹⁾ - 5.6	8.6 - 8.8 ⁽¹⁾
Quinta Ace 160	5.2 ⁽¹⁾ - 5.6	8.6 - 8.8 ⁽¹⁾
⁽¹⁾ Nominal value		

Tab.34 Checking/setting values for O₂/CO₂ at part load for G30/G31 (butane/propane)

Values at part load for G30/G31 (butane/propane)	O ₂ (%) ⁽¹⁾	CO ₂ (%) ⁽¹⁾
Quinta Ace 135	- ⁽¹⁾ - -	- - - ⁽¹⁾
Quinta Ace 160	5.4 ⁽¹⁾ - 5.7	10.0 - 10.2 ⁽¹⁾
⁽¹⁾ Nominal value		

Caution

- The O₂ values at part load must be higher than the O₂ values at full load.
- The CO₂ values at part load must be lower than the CO₂ values at full load.

Fig.45 Position of adjusting screw B

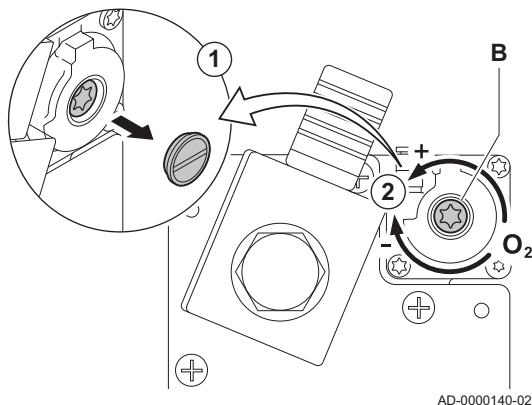

7.7 Final instructions

3. If the measured value is outside of the values given in the table, correct the gas/air ratio.
4. Using the adjusting screw **B**, set the percentage of O₂/CO₂ for the gas type being used to the nominal value. This should always be within the maximum and the minimum setting limits.

1. Remove the measuring equipment.
2. Screw the cap on to the flue gas measuring point.
3. Seal the gas valve unit.
4. Put the front casing back.
5. Heat up the central heating system to approximately 70°C.
6. Switch the boiler off.
7. Vent the central heating system after approx. 10 minutes.
8. Turn on the boiler.
9. Check the water pressure. If necessary, top up the central heating system.
10. Fill in the following data on the sticker included, and attach it next to the data plate on the appliance.
 - The gas type, if adapted to another gas;
 - The gas supply pressure;
 - The flue type, if set to overpressure application;
 - The parameters modified for the changes mentioned above;
 - Any fan speed parameters modified for other purposes.
11. Optimise the settings as required for the system and user preferences.
12. Save the commissioning settings on the control panel, so they can be restored after a reset.
13. Instruct the user in the operation of the system, boiler and controller.
14. Inform the user of the maintenance to be performed.
15. Hand over all manuals to the user.

Fig.46 Example filled-in sticker

<p>Adjusted for / Réglée pour / Ingesteld op / Eingestellt auf / Regolato per / Ajustado para / Ρυθμισμένο για / Nastawiony na / настроен для / Reglat pentru / настроен за / ayarlanmıştır / Nastavljen za / beállítva/ Nastaveno pro / Asetettu kaasulle / Justert for/ indstillet til/ ل تطبخ :</p> <p><input checked="" type="checkbox"/> Gas <u>G20</u></p> <p><u>20</u> mbar</p> <p><input checked="" type="checkbox"/> C_{(10)3(X)}</p> <p><input type="checkbox"/> C_{(12)3(X)}</p> <p><input type="checkbox"/></p>	<p>Parameters / Paramètres / Parameter / Parametri / Parámetros / Παράμετροι / Parametry / Параметри / Parametrii / Параметри / Parametreler / Paraméterek / Parametrit / Parametere / Parametre / تامل عمل :</p> <p><u>DP003 - 3300</u></p> <p><u>GP007 - 3300</u></p> <p><u>GP008 - 2150</u></p> <p><u>GP009 -</u></p>
--	---

AD-3001124-01

8 Operation

8.1 Use of the control panel

8.1.1 Description of the home screen

This screen is shown automatically after start-up of the appliance. The control panel goes automatically in standby mode (black screen) if the screen is not touched for 5 minutes. Press one of the buttons on the control panel to activate the screen again.

You can navigate from any menu to the home screen by pressing the back button  for several seconds.





The tiles on the home screen provide quick access to the corresponding menus. Use the rotary knob to navigate to the menu of your choice and press the button  to confirm the selection.

Fig.47 Icons on home screen

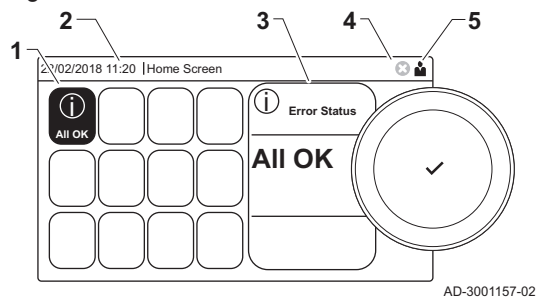

- 1 Tiles: the selected tile is highlighted
- 2 Date and time | Name of the screen (actual position in the menu)
- 3 Information about the selected tile
- 4 Error indicator (only visible if an error has been found)
- 5 Icon showing the navigation level:

- : Chimney sweeper level
- : User level
- : Installer level

The installer level is protected by an access code. When this level is active, the status of the tile [] changes from **Off** into **On**.

8.1.2 Description of the main menu



You can navigate from any menu directly to the main menu by pressing the menu button . The number of accessible menus depends on the access level (user or installer).

Fig.48 Items in the main menu





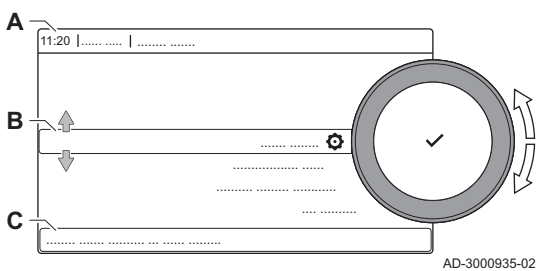

- A Date and time | Name of the screen (actual position in the menu)
- B Available menus
- C Brief explanation of the selected menu

Tab.35 Available menus for the user 





























Description	Icon
System Settings	
Version Information	i

Tab.36 Available menus for the installer 







Description	Icon
Installation Setup	
Commissioning Menu	
Advanced Service Menu	
Error History	
System Settings	
Version Information	i

■ Meaning of the icons in the display

Tab.37 Icons

Icon	Description
	User menu: user-level parameters can be configured.
	Installer menu: installer-level parameter can be configured.
i	Information menu: read out various current values.
	System settings: system parameters can be configured.
	Error indicator.
	Gas boiler indicator.
	Domestic hot water tank is connected.
	The outdoor temperature sensor is connected.
	Boiler number in cascade system.
	The solar calorifier is on and its heat level is displayed.
	CH operation is enabled.
	CH operation is disabled.
	DHW operation is enabled.
	DHW operation is disabled.
	The burner is on.
	The burner is off.
	Burner output level (1 to 5 bars, with each bar representing 20% output).
	The pump is running.
	Three-way valve indicator.
	Display of the system water pressure.
	Chimney sweep mode is enabled (forced full load or low load for O ₂ /CO ₂ measurement).
	Energy-saving mode is enabled.
	DHW boost is enabled.
	Timer program is enabled: The room temperature is controlled by a timer program.
	Manual mode is enabled: The room temperature is set to a fixed setting.
	Temporary overwrite of the timer program is enabled: The room temperature is changed temporarily.
	The holiday program (including frost protection) is active: The room temperature is reduced during your holiday to save energy.
	Frost protection is enabled: Protect the boiler and installation from freezing in winter.
	Installer contact details are displayed or can be filled in.

Tab.38 Icons - Zones

Icon	Description
	All zones (groups) icon.
	Living room icon.
	Kitchen icon.
	Bedroom icon.
	Study icon.
	Cellar icon.

8.2 Shut-down

Shut-down the boiler as follows:

1. Turn off the boiler using the on/off switch.

2. Shut off the gas supply.
3. Keep the installation frost-free.
Do not shut-down the boiler if the installation can't be kept frost-free.

8.3 Frost protection



Caution

- Drain the boiler and central heating system if you are not going to use your home or the building for a long time and there is a chance of frost.
- The frost protection does not work if the boiler is out of operation.
- The built-in boiler protection is only activated for the boiler and not for the system and radiators.
- Open the valves of all the radiators connected to the system.

Set the temperature control low, for example to 10°C.

If there is no heat demand, the boiler will only switch on to protect itself against frost.

If the temperature of the central heating water in the boiler drops too low, the built-in boiler protection system is activated. This system works as follows:

- At a water temperature lower than 7°C, the heating pump starts.
- If the water temperature is lower than 4°C, the boiler switches on.
- If the water temperature is higher than 10°C the boiler switches off and the circulation pump continues to run for a short time.

To prevent the system and radiators freezing in frost-sensitive areas (e.g. a garage), a frost thermostat or outside sensor can be connected to the boiler.

9 Settings

9.1 Changing the parameters

The boiler's control unit is set for the most common central heating systems. These settings will ensure that virtually every central heating system operates effectively. The user or the installer can optimise the parameters as required.



Caution

Changing the factory settings may adversely affect the operation of the boiler.

9.1.1 Accessing the installer level

Some parameters that may affect the operation of the boiler are protected by an access code. Only the installer is allowed to modify these parameters.

1. Select the tile [🔧].
2. Press the ✓ button to confirm the selection.
3. Use the rotary knob to select code: **0012**.
4. Press the ✓ button to confirm the selection.
 - ⇒ When the installer level is enabled, the status of the tile [🔧] changes from **Off** into **On**.
5. To leave the installer level, select the tile [🔧].
6. Use the rotary knob to select **Confirm** or **Cancel**.
7. Press the ✓ button to confirm the selection.
 - ⇒ When the installer level is disabled, the status of the tile [🔧] changes from **On** into **Off**.

Fig.49 Installer level

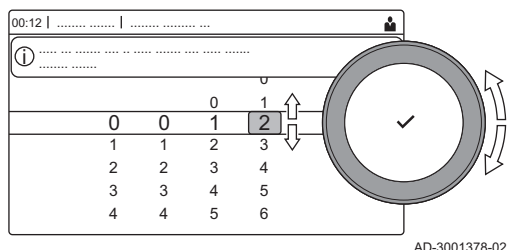

When the control panel is not used for 30 minutes, the installer level is left automatically.

■ Configuring the installation at installer level

Configure the installation by pressing the ≡ button and selecting **Installation Setup** [🔧]. Select the control unit or circuit board you want to configure:

Tab.39 FSB-WHB-HE-150-300

Icon	Zone or function	Description
	CIRCA / CH	Central heating circuit
🔧	Commercial boiler	Gas boiler
🔧	Gas fired appliance	Gas boiler

Tab.40 Configuring a zone or function of FSB-WHB-HE-150-300

Parameters, counters, signals	Description
Parameters	Set the parameters at installer level
Counters	Read the counters at installer level
Signals	Read the signals at installer level
Adv. Parameters	Set the parameters at advanced installer level
Adv. Counters	Read the counters at advanced installer level
Adv. Signals	Read the signals at advanced installer level

9.2 List of parameters

The code of the parameters always contain two letters and three numbers. The letters stand for:

AP	Appliance related parameters
CP	Zone related parameters
DP	Domestic hot water related parameters
EP	Smart Solutions related parameters
GP	Gas-fired heat engine related parameters
PP	Central heating related parameters

**Important**

All possible options are indicated in the adjustment range. The display of the boiler only shows the relevant settings for the appliance.

**For more information, see**

Changing the parameters, page 51

9.2.1 CU-GH06c Control Unit settings

All tables show the factory setting for the parameters.

**Important**

The tables also list parameters that are only applicable if the boiler is combined with other equipment.

Tab.41 Navigation for basic installer level

Level	Menu path
Basic installer	☰ > Installation Setup > CU-GH-06 > Submenu ⁽¹⁾ > Parameters, counters, signals > Parameters
(1) See the column "Submenu" in the following table for the correct navigation. The parameters are grouped in specific functionalities.	

Tab.42 Factory settings at basic installer level

Code	Display text	Description	Adjustment range	Submenu	135	160
AP016	CH function on	Enable central heating heat demand processing	0 = Off 1 = On	Commercial boiler	1	1
AP017	DHW function on	Enable domestic hot water heat demand processing	0 = Off 1 = On	Commercial boiler	1	1
CP080	User T.Room Activity	Room setpoint temperature of the user zone activity	5 - 30 °C	Direct zone	16	16
CP081	User T.Room Activity	Room setpoint temperature of the user zone activity	5 - 30 °C	Direct zone	20	20
CP082	User T.Room Activity	Room setpoint temperature of the user zone activity	5 - 30 °C	Direct zone	6	6
CP083	User T.Room Activity	Room setpoint temperature of the user zone activity	5 - 30 °C	Direct zone	21	21
CP084	User T.Room Activity	Room setpoint temperature of the user zone activity	5 - 30 °C	Direct zone	22	22
CP085	User T.Room Activity	Room setpoint temperature of the user zone activity	5 - 30 °C	Direct zone	20	20
CP200	Manu ZoneRoomTempSet	Manually setting the room temperature setpoint of the zone	5 - 30 °C	Direct zone	20	20
CP320	OperatingZone-Mode	Operating mode of the zone	0 = Scheduling 1 = Manual 2 = Antifrost 3 = Temporary	Direct zone	1	1
CP550	Zone, fire place	Fire Place mode is active	0 = Off 1 = On	Direct zone	0	0

Code	Display text	Description	Adjustment range	Submenu	135	160
CP570	ZoneTimeProg Select	Time Program of the zone selected by the user	0 = Schedule 1 1 = Schedule 2 2 = Schedule 3 3 = Cooling	Direct zone	0	0
CP660	Icon display zone	Choice icon to display this zone	0 = None 1 = All 2 = Bedroom 3 = Livingroom 4 = Study 5 = Outdoor 6 = Kitchen 7 = Basement 8 = Swimming Pool 9 = DHW Tank 10 = DHW Electrical Tank 11 = DHW Layered Tank 12 = Internal Boiler Tank 13 = Time Program	Direct zone	1	1

Tab.43 Navigation for installer level

Level	Menu path
Installer	☰ > Installation Setup > CU-GH-06 > Submenu ⁽¹⁾ > Parameters, counters, signals > Parameters
(1) See the column "Submenu" in the following table for the correct navigation. The parameters are grouped in specific functionalities.	

Tab.44 Factory settings at installer level

Code	Display text	Description	Adjustment range	Submenu	135	160
AP001	BL function	BL input function selection	1 = Full blocking 2 = Partial blocking 3 = User reset locking 4 = Backup relieved 5 = Generator relieved 6 = Gen.&Backup relieved 7 = High, Low Tariff 8 = Photovoltaic HP Only 9 = PV HP And backup 10 = Smart Grid ready 11 = Heating Cooling =	Commercial boiler	1	1
AP006	Min. water pressure	Appliance will report low water pressure below this value	0 - 7 bar	Commercial boiler	0.7	0.7
AP008	Release wait time	Waiting time after closing the release contact to start the heat generator.	0 - 255 Sec	Commercial boiler	0	0
AP009	Service hours	Number of heat generator operating hours for raising a service notification	24 - 51000 Hours	Commercial boiler	17400	17400
AP010	Service notification	Select the type of service notification	0 = None 1 = Custom notification 2 = ABC notification	Commercial boiler	2	2
AP011	Service hours mains	Hours powered to raise a service notification	24 - 51000 Hours	Commercial boiler	17400	17400
AP073	Summer Winter	Outdoor temperature: upper limit for heating	1.5 - 60 °C	Outdoor temperature	22	22
AP074	Force summer mode	The heating is stopped. Hot water is maintained. Force Summer Mode	0 = Off 1 = On	Outdoor temperature	0	0

Code	Display text	Description	Adjustment range	Submenu	135	160
AP079	Building Inertia	Inertia of the building used for heat up speed	0 - 255	Outdoor temperature	0	0
AP080	Frost min out temp	Outside temperature below which the antifreeze protection is activated	-32 - 32 °C	Outdoor temperature	0	0
AP102	Boiler Pump function	Configuration of the boiler pump as zone pump or system pump (feed lowloss header)	0 = No 1 = Yes	Commercial boiler	0	0
AP110	2nd return sensor	Parameter to activate the 2nd return sensor	0 = Inactive 1 = Active	Commercial boiler	0	0
CP000	MaxZoneT-FlowSetpoint	Maximum Flow Temperature setpoint zone	0 - 90 °C	Direct zone	90	90
CP010	Tflow setpoint zone	Zone flow temperature setpoint, used when the zone is set to a fixed flow setpoint.	0 - 90 °C	Direct zone	90	90
CP020	Zone Function	Functionality of the zone	0 = Disable 1 = Direct 2 = Mixing Circuit 3 = Swimming pool 4 = High Temperature 5 = Fan Convactor 6 = DHW tank 7 = Electrical DHW 8 = Time Program 9 = ProcessHeat 10 = DHW Layered 11 = DHW Internal tank 12 = DHW Commercial Tank 13 = DHW FWS 31 = DHW FWS EXT 200 = BSB 254 = Occupied	Zone disabled Direct zone	1	1
CP060	RoomT. Holiday	Wished room zone temperature on holiday period	5 - 20 °C	Direct zone	6	6
CP070	MaxReducedRoomT.Lim	Max Room Temperature limit of the circuit in reduced mode, that allows switching to comfort mode	5 - 30 °C	Direct zone	15	15
CP210	Zone HCZP Comfort	Comfort footpoint of the temperature of heat curve of the circuit	15 - 90 °C	Direct zone	15	15
CP220	Zone HCZP Reduced	Reduced footpoint of the temperature of heat curve of the circuit	15 - 90 °C	Direct zone	15	15
CP230	Zone Heating Curve	Heating curve temperature gradient of the zone	0 - 4	Direct zone	2.5	2.5
CP340	TypeReduced-NightMode	Type of reduced night mode, stop or maintain heating of circuit	0 = Stop heat demand 1 = Continue heat demand	Direct zone	0	0
CP470	Zone screed drying	Setting of the screed drying program of the zone	0 - 30 Days	Direct zone	0	0
CP480	ScreedStart-Temp	Setting of the start temperature of the screed drying program of the zone	20 - 50 °C	Direct zone	20	20
CP490	ScreedStop-Temp	Setting of the stop temperature of the screed drying program of the zone	20 - 50 °C	Direct zone	20	20
CP750	MaxZone Pre-heat time	Maximum zone preheat time	0 - 65000 Min	Direct zone	0	0

Code	Display text	Description	Adjustment range	Submenu	135	160
CP780	Control strategy	Selection of the control strategy for the zone	0 = Automatic 1 = Room Temp. based 2 = Outdoor Temp. based 3 = Outdoor & room based	Direct zone	1	1
DP003	Abs. max fan DHW	Maximum fan speed on Domestic Hot Water	1000 - 8500 Rpm	Commercial boiler	5700	6700
DP010	Hysteresis DHW	Temperature hysteresis for the heat generator to start on domestic hot water production	0 - 60 °C	Commercial boiler	7	7
DP011	Stop offset DHW	Temperature offset to stop heat generator on domestic hot water production	0 - 60 °C	Commercial boiler	5	5
EP014	SCB func. 10V PWMIn	Smart Control Board function 10 Volt PWM input	0 = Off 1 = Temperature control 2 = Power control	0-10 volt input	0	0
GP007	Fan RPM Max CH	Maximum fan speed during Central Heating mode	1000 - 8500 Rpm	Commercial boiler	5700	6700
GP008	Fan RPM Min	Minimum fan speed during Central Heating + Domestic Hot Water mode	900 - 8500 Rpm	Commercial boiler GVC Pneumatic	1900	1900
GP009	Fan RPM Start	Fan speed at appliance start	900 - 5000 Rpm	Commercial boiler GVC Pneumatic	2200	2200
GP010	GPS Check	Gas Pressure Switch check on/off	0 = No 1 = Yes	Commercial boiler	0	0
GP021	Temp diff Modulating	Modulate back when delta temperature is large then this threshold	5 - 25 or 40 °C	Commercial boiler	40	25
GP022	Tfa Filter Tau	Tau factor for average flow temperature calculation	0 - 255	Commercial boiler	1	1
GP024	VPS Check	Valve Proofing System check on / off	0 = No 1 = Yes	Commercial boiler GVC Pneumatic	0	0
PP007	Min anti-cycle time	Minimum heat generator holding time that can be reached after a stop	0 - 20 Min	Commercial boiler	3	3
PP012	Stabilization time	Stabilization time after heat generator start for central heating	5 - 180 Sec	Commercial boiler	30	30
PP015	CH Pump post-run time	Central heating pump post run time	1 - 99 Min	Commercial boiler	1	1
PP016	Max. CH pump speed	Maximum central heating pump speed (%)	20 - 100 %	Commercial boiler	100	100
PP018	Min CH pump speed	Minimum central heating pump speed (%)	20 - 100 %	Commercial boiler	20	20
PP023	CH Hysteresis	Temperature hysteresis for the generator to start on central heating	1 - 25 °C	Commercial boiler	10	10

Tab.45 Navigation for advanced installer level

Level	Menu path
Advanced installer	☰ > Installation Setup > CU-GH-06 > Submenu ⁽¹⁾ > Parameters, counters, signals > Adv. Parameters
(1) See the column "Submenu" in the following table for the correct navigation. The parameters are grouped in specific functionalities.	

Tab.46 Factory settings at advanced installer level

Code	Display text	Description	Adjustment range	Submenu	135	160
AP002	Manual Heat Demand	Enable manual heat demand function	0 = Off 1 = With setpoint 2 = TOutdoor Control	Commercial boiler	0	0
AP026	Setpoint manual HD	Flow temperature setpoint for manual heat demand	7 - 90 °C	Commercial boiler	40	40
AP056	Outdoor sensor	Enable outdoor sensor	0 = No outside sensor 1 = AF60 2 = QAC34	Outdoor temperature	1	1
AP089	Installer name	Name of the installer		Mandatory bus master		
AP090	Installer phone	Telephone number of the installer		Mandatory bus master	6	6
CP040	Postrun zone pump	Pump post runtime of the zone	0 - 20 Min	Direct zone	0	0
CP240	ZoneRoomUnitInfl	Adjustment of the influence of the zone room unit	0 - 10	Direct zone	3	3
CP250	CalSondeAmb-Zone	Calibration of Zone Room Unit	-5 - 5 °C	Direct zone	0	0
CP290	ConfigZone-PumpOut	Configuration of Zone Pump Output	0 = Zone output 1 = CH mode 2 = DHW mode 3 = Cooling mode 4 = Error report 5 = Burning 6 = Service flag 7 = System error 8 = DHW looping 9 = Primary pump 10 = Buffer pump	Zone disabled Direct zone	0	0
CP510	Temporary Room Setp	Temporary room setpoint per zone	5 - 50 °C	Direct zone	20	20
GP030	Flue Gas Temp Max	Maximum flue gas temperature	20 - 200 °C	Commercial boiler	120	120
GP048	Fan PWM Min	Minimum Pulse Width Modulation for the fan controller	0 - 100 %	GVC Pneumatic	10	10
GP050	Power Min	Minimum power in kilo Watt for RT2012 calculation	0 - 300 kW	Commercial boiler	5.3	5.3
GP056	Grad. 1 power reduct	Factor of power reduction when temperature gradient > parHeDTh-MaxLevel1 is detected	0 - 1000	Commercial boiler	1	1
PP017	ChPumpSpeed-MaxFactor	Maximum central heating at minimum load as percentage of max pump speed	0 - 100 %	Commercial boiler	30	30

9.3 Reading out measured values

The control unit continually registers various values from the boiler and the connected sensors. These values can be read on the control panel of the boiler.



1. Select the tile .
2. Press the  button to confirm the selection.

Fig.50 Installer level



AD-3001378-02

3. Use the rotary knob to select code: **0012**.
4. Press the ✓ button to confirm the selection.
 - ⇒ When the installer level is enabled, the status of the tile [] changes from **Off** into **On**.
5. Press the ≡ button.
6. Use the rotary knob to select **Installation Setup**.
7. Press the ✓ button to confirm the selection.
8. Use the rotary knob to select the zone or device you want to read out.
9. Press the ✓ button to confirm the selection.
10. Use the rotary knob to select **Parameters, counters, signals**.
11. Press the ✓ button to confirm the selection.
12. Use the rotary knob to select **Counters** or **Signals** to read out a counter or signal.
13. Press the ✓ button to confirm the selection.
14. If available, select **Adv. Counters** or **Adv. Signals** to read out counters or signals at the advanced installer level.

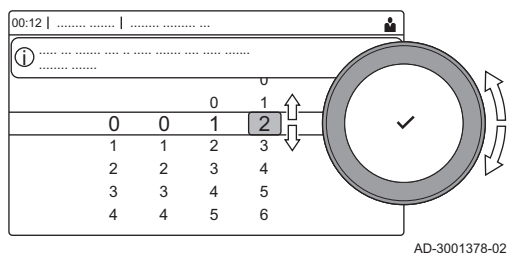
Fig.51 Parameters, counters, signals

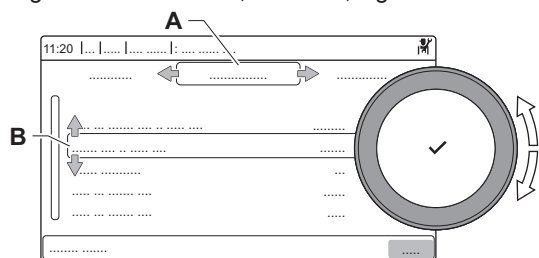

AD-3000936-02

- A - Parameters
 - Counters
 - Signals
 - Adv. Parameters
 - Adv. Counters
 - Adv. Signals
- B List of settings or values

9.4 List of measured values



For more information, see
Reading out measured values, page 0

9.4.1 CU-GH06c Control Unit counters

Tab.47 Navigation for basic installer level

Level	Menu path
Basic installer	≡ > Installation Setup > FSB-WHB-HE-150-300 > Submenu ⁽¹⁾ > Parameters, counters, signals > Counters

(1) See the column "Submenu" in the following table for the correct navigation. The counters are grouped in specific functionalities.

Tab.48 Counters at basic installer level

Code	Display text	Description	Range	Submenu
AC002	Service run hours	Number of hours that the appliance has been producing energy since last service	0 - 131070 Hours	Commercial boiler
AC003	Hours since service	Number of hours since the previous servicing of the appliance	0 - 131070 Hours	Commercial boiler
AC004	Starts since service	Number of heat generator starts since the previous servicing.	0 - 4294967295	Commercial boiler
AC005	CH Energy Consumed	Energy consumed for central heating	0 - 4294967295 kWh	Commercial boiler
AC006	DHW energy consumed	Energy consumed for domestic hot water	0 - 4294967295 kWh	Commercial boiler
AC007	Cool Energy consumed	Energy consumed for cooling	0 - 4294967295 kWh	Commercial boiler
AC026	Pump running hours	Counter that shows the number of pump running hours	0 - 4294967295 Hours	Commercial boiler
AC027	Pump starts	Counter that shows the number of pump starts	0 - 4294967295	Commercial boiler

Code	Display text	Description	Range	Submenu
DC002	DHW valve cycles	Numbers of Domestic Hot Water diverting valve cycles	0 - 4294967295	Commercial boiler
DC003	Hrs DHW 3wv	Number of hours during which the diverting valve is in DHW position	0 - 4294967295 Hours	Commercial boiler
DC004	DHW starts	Number of starts for domestic hot water	0 - 4294967295	Commercial boiler
DC005	DHW run hours	Total number of hours that the appliance has been producing energy for domestic hot water	0 - 4294967295 Hours	Commercial boiler
PC003	Heat gen run hrs	Total Number of hours that the appliance has been producing energy for central heating and DHW	0 - 65534 Hours	Commercial boiler

Tab.49 Navigation for installer level

Level	Menu path
Installer	☰ > Installation Setup > FSB-WHB-HE-150-300 > Submenu ⁽¹⁾ > Parameters, counters, signals > Counters
(1) See the column "Submenu" in the following table for the correct navigation. The counters are grouped in specific functionalities.	

Tab.50 Counters at installer level

Code	Display text	Description	Range	Submenu
DC001	DhwTotalPower Cons	Total power consumption used by Domestic Hot Water	0 - 4294967295 kW	Commercial boiler
PC002	Total starts	Total number of heat generator starts. For heating and domestic hot water	0 - 65534	Commercial boiler
PC004	Burner flame loss	Number of burner flame loss	0 - 65534	Commercial boiler

Tab.51 Navigation for advanced installer level

Level	Menu path
Advanced installer	☰ > Installation Setup > FSB-WHB-HE-150-300 > Submenu ⁽¹⁾ > Parameters, counters, signals > Adv. Counters
(1) See the column "Submenu" in the following table for the correct navigation. The counters are grouped in specific functionalities.	

Tab.52 Counters at advanced installer level



Code	Display text	Description	Range	Submenu
PC001	ChCtrTotalPower-Cons.	Total power consumption used by Central Heating	0 - 4294967295 kW	Commercial boiler

9.4.2 CU-GH06c Control Unit signals

Tab.53 Navigation for basic installer level

Level	Menu path
Basic installer	☰ > Installation Setup > FSB-WHB-HE-150-300 > Submenu ⁽¹⁾ > Parameters, counters, signals > Signals
(1) See the column "Submenu" in the following table for the correct navigation. The signals are grouped in specific functionalities.	

Tab.54 Signals at basic installer level

Code	Display text	Description	Range	Submenu
AM001	DHW active	Is the appliance currently in domestic hot water production mode?	0 = Off 1 = On	Commercial boiler
AM010	Pump speed	The current pump speed	0 - 100 %	Commercial boiler
AM012	Status Appliance	Current main status of the appliance.	 See Status and sub-status, page 62	Status information
AM014	Sub status Appliance	Current sub status of the appliance.	 See Status and sub-status, page 62	Status information
AM015	Pump running?	Is the pump running?	0 = Inactive 1 = Active	Commercial boiler
AM016	System Flow Temp	Flow temperature of appliance.	-25 - 150 °C	Zone manager Commercial boiler Prod. manager bridge
AM017	T heat exchanger	The temperature of heat exchanger	-25 - 150 °C	Commercial boiler
AM018	T return	Return temperature of appliance. The temperature of the water entering the appliance.	-25 - 150 °C	Zone manager Commercial boiler
AM019	Water pressure	Water pressure of the primary circuit.	0 - 25.5 bar	Commercial boiler
AM022	On / Off heat demand	On / Off heat demand	0 = Off 1 = On	Commercial boiler
AM024	Actual rel. Power	Actual relative power of the appliance	0 - 655.35 %	Commercial boiler
AM027	Outside temperature	Instantaneous outside temperature	-60 - 60 °C	Outdoor temperature Commercial boiler
AM028	0to10Vinput	Value of the 0 to 10 Volt input. Meaning is dependant on the current input function setting.	0 - 25 V	0-10 volt input
AM037	3 way valve	Status of the three way valve	0 = CH 1 = DHW	Commercial boiler
AM040	Control temperature	Temperature used for hot water control algorithms.	-25 - 150 °C	Commercial boiler
AM101	Internal setpoint	Internal system flow temperature setpoint	0 - 120 °C	Commercial boiler
AP078	Out sensor detected	Outside sensor detected in the application	0 = No 1 = Yes	Outdoor temperature
GM001	Actual fan RPM	Actual fan RPM	0 - 8500 Rpm	Commercial boiler
GM002	Fan RPM setpoint	Actual fan RPM setpoint	0 - 8500 Rpm	Commercial boiler
GM006	GPS status	Gas Pressure Switch status	0 = Open 1 = Closed 2 = Off	Commercial boiler
GM008	Actual flame current	Actual flame current measured	0 - 25 µA	Commercial boiler

Code	Display text	Description	Range	Submenu
GM012	Release Input	Release signal for the CU	0 = No 1 = Yes	Commercial boiler
GM015	Vps Switch	Valve Proving System switch open / closed	0 = Open 1 = Closed 2 = Off	Commercial boiler

Tab.55 Navigation for installer level

Level	Menu path
Installer	☰ > Installation Setup > FSB-WHB-HE-150-300 > Submenu ⁽¹⁾ > Parameters, counters, signals > Signals
(1) See the column "Submenu" in the following table for the correct navigation. The signals are grouped in specific functionalities.	

Tab.56 Signals at installer level

Code	Display text	Description	Range	Submenu
AM011	Service required?	Is service currently required?	0 = No 1 = Yes	Commercial boiler
AM033	Next Service Ind.	Next service indication	0 = None 1 = A 2 = B 3 = C 4 = Custom	Commercial boiler
AM036	Flue gas temperature	Temperature of the exhaust gas leaving the appliance	0 - 250 °C	Commercial boiler
AM044	Nr sensors supported	Number of sensors supported by the device	0 - 255	Commercial boiler
AM045	Water P available	Water pressure sensor present?	0 = No 1 = Yes	Commercial boiler
AM091	SeasonMode	Seasonal mode active (summer / winter)	0 = Winter 1 = Frost protection 2 = Summer neutral band 3 = Summer	Outdoor temperature
CM030	Zone RoomTemperature	Measure of the room temperature of the zone	-60 - 60 °C	Direct zone
CM120	ZoneCurrentMode	Zone Current Mode	0 = Scheduling 1 = Manual 2 = Antifrost 3 = Temporary	Direct zone
CM130	ZoneCurrent activity	Current activity of the zone	0 = Anti frost 1 = Reduced 2 = Comfort 3 = Anti legionella	Direct zone
CM140	ZoneOTContr present	OpenTherm controller is connected to the zone	0 = No 1 = Yes	Direct zone
CM150	ZoneState Heatdemand	State of On Off heat demand per zone	0 = No 1 = Yes	Direct zone
CM160	Zone Mod HeatDemand	Presense of modulating heat demand per zone	0 = No 1 = Yes	Direct zone
CM170	Zone OTSmartPower	Zone OpenTherm smart power function is available	0 = No 1 = Yes	Direct zone
CM180	Zone RU present	Presense of Room Unit in this zone	0 = No 1 = Yes	Direct zone
CM190	Zone Troom setpoint	Wished room temperature setpoint of the zone	-60 - 60 °C	Direct zone
CM200	ZoneCurrentHeatMode	Displaying current operating mode of the zone	0 = Standby 1 = Heating 2 = Cooling	Direct zone

Code	Display text	Description	Range	Submenu
CM210	ZoneTout temp	Current outdoor temperature of the zone	-60 - 60 °C	Direct zone
CM230	ZoneTout aver long	Outdoor temperature average long time per zone	-60 - 60 °C	Direct zone
CM260	Zone T Room Sensor	Measurement of the room sensor temperature of the zone	-60 - 60 °C	Direct zone
GM004	Gas valve 1	Gas valve 1	0 = Open 1 = Closed 2 = Off	Commercial boiler
GM005	Gas valve 2	Gas valve 2	0 = Open 1 = Closed 2 = Off	Commercial boiler
GM010	Power available	Available power in % of maximum	0 - 100 %	Commercial boiler
GM044	ControlledStopReason	Possible reason for Controlled Stop	0 = None 1 = CH Blocking 2 = DHW Blocking 3 = Wait for burner 4 = TFlow > absolute max 5 = TFlow > start temp. 6 = Theat exch. > Tstart 7 = Avg Tflow > Tstart 8 = TFlow > max setpoint 9 = T difference too big 10 = TFlow > stop temp. 11 = Anti cycle on off HD 12 = Poor combustion 13 = Solar T above stop T	Commercial boiler
NM001	CascSystemTF	Cascade system flow temperature	-60 - 125 °C	Producer<>Consumer
PM002	CH Setpoint	Central heating setpoint of the appliance	0 - 125 °C	Commercial boiler

Tab.57 Navigation for advanced installer level

Level	Menu path
Advanced installer	☰ > Installation Setup > FSB-WHB-HE-150-300 > Submenu ⁽¹⁾ > Parameters, counters, signals > Adv. Signals
(1) See the column "Submenu" in the following table for the correct navigation. The signals are grouped in specific functionalities.	

Tab.58 Signals at advanced installer level

Code	Display text	Description	Range	Submenu
AM043	Pwr dwn reset needed	A power down reset is needed	0 = No 1 = Yes	Commercial boiler
CM070	Zone Tflow Setpoint	Current Flow temperature setpoint of zone	0 - 100 °C	Direct zone
GM003	Flame detection	Flame detection	0 = Off 1 = On	Commercial boiler
GM007	Ignite	Appliance is igniting	0 = Off 1 = On	Commercial boiler
GM011	Power setpoint	Power setpoint in % of maximum	0 - 100 %	Commercial boiler
GM013	Blocking Input	Blocking input status	0 = Open 1 = Closed 2 = Off	Commercial boiler

Code	Display text	Description	Range	Submenu
GM025	STB status	High limit status (0 = open, 1 = closed)	0 = Open 1 = Closed 2 = Off	Commercial boiler
PM003	ChTflowAverage	Actual average flow temperature	-25 - 125 °C	Commercial boiler

9.4.3 Status and sub-status

Tab.59 AM012 - Status

Code	Display text	Explanation
0	Standby	The appliance is in standby mode.
1	Heat Demand	A heat demand is active.
2	Generator start	The appliance starts.
3	Generator CH	The appliance is active for central heating.
4	Generator DHW	The appliance is active for domestic hot water.
5	Generator stop	The appliance has stopped.
6	Pump Post Run	The pump is active after the appliance stopped.
7	Cooling Active	The appliance is active for cooling.
8	Controlled Stop	The appliance does not start because the starting conditions are not met.
9	Blocking Mode	A blocking mode is active.
10	Locking Mode	A locking mode is active.
11	Load test min	Low load test mode for central heating is active.
12	Load test CH max	Full load test mode for central heating is active.
13	Load test DHW max	Full load test mode for domestic hot water is active.
15	Manual Heat Demand	Manual heat demand for central heating is active.
16	Frost Protection	Frost protection mode is active.
17	DeAiration	The deaeration program operates.
18	Control unit Cooling	The fan runs to cool the inside of the appliance.
19	Reset In Progress	The appliance resets.
20	Auto Filling	The appliance fills the installation.
21	Halted	The appliance has stopped. It must be reset manually.
200	Device Mode	The service tool interface controls the functions of the appliance.

Tab.60 AM014 - Sub status

Code	Display text	Explanation
0	Standby	The appliance waits for a process or an action.
1	AntiCycling	The appliance waits to restart, because there were too many consecutive heat demands (anti-short cycle).
2	CloseHydraulicValve	An external hydraulic valve is opened, when this option is connected to the appliance. An external option board must be connected to drive the valve.
3	ClosePump	The appliance starts the pump.
4	WaitingForStartCond.	The appliance waits for the temperature to meet the start conditions.
10	CloseExtGasValve	An external gas valve is opened, when this option is connected to the appliance. An external option board must be connected to drive the valve.
11	StartToGlueGasValve	The fan runs faster, before the flue gas valve is opened.
12	CloseFlueGasValve	The flue gas valve opens.
13	FanToPrePurge	The fan runs faster to pre-purge.
14	WaitForReleaseSignal	The appliance waits for the release input to close.
15	BurnerOnCommandToSu	A burner start command is sent to the safety core.
16	VpsTest	Valve proving test is active.
17	Prelgnition	Ignition starts before the gas valve opens.
18	Ignition	Ignition is active.

Code	Display text	Explanation
19	FlameCheck	The flame detection is active after the ignition.
20	Interpurge	The fan runs to purge the heat exchanger after a failed ignition.
30	Normal Int.Setpoint	The appliance operates to reach the desired value.
31	Limited Int.Setpoint	The appliance operates to reach the reduced internal desired value.
32	NormalPowerControl	The appliance operates on the desired power level.
33	GradLevel1PowerCtrl	The modulation is stopped due to a faster heat exchanger temperature change than gradient level 1.
34	GradLevel2PowerCtrl	The modulation is set to low load due to a faster heat exchanger temperature change than gradient level 2.
35	GradLevel3PowerCtrl	The appliance is in blocking mode due to a faster heat exchanger temperature change than gradient level 3.
36	ProtectFlamePwrCtrl	The burner power is increased due to a low ionisation signal.
37	StabilizationTime	The appliance is in stabilisation time. Temperatures should stabilise and temperature protections are switched off.
38	ColdStart	The appliance runs at start load to prevent cold start noise.
39	ChResume	The appliance resumes central heating after a domestic hot water interruption.
40	SuRemoveBurner	Burner demand is removed from safety core.
41	FanToPostPurge	The fan runs to purge the heat exchanger after the appliance stopped.
42	OpenExtFlueGasValve	External gas valve closes.
43	StopFanToFlueGVRpm	The fan runs slower, before the flue gas valve is closed.
44	StopFan	The fan has stopped.
45	LimitedPwrOnTflueGas	The power of the appliance is decreased to lower the flue gas temperature.
60	PumpPostRunning	The pump is active after the appliance stopped in order to bring the remaining heat into the system.
61	OpenPump	The pump has stopped.
62	OpenHydraulicValve	The external hydraulic valve closes.
63	SetAntiCycleTimer	
200	Initialising Done	Initialisation is finished.
201	Initialising Csu	The CSU is initialising.
202	Init. Identifiers	The identifiers are initialising.
203	Init.BL.Parameter	The blocking parameters are initialising.
204	Init. Safety Unit	The safety unit is initialising.
205	Init. Blocking	The blocking is initialising.

10 Maintenance

10.1 General

The boiler does not require a lot of maintenance. Nevertheless, the boiler must be inspected and maintained periodically. To determine the best time for servicing, the boiler is equipped with an automatic service message. The control unit determines when this service message appears.



Caution

- Maintenance operations must be completed by a qualified installer.
- During inspection or maintenance work, always replace all gaskets of the disassembled parts.
- We recommend taking out a maintenance contract.
- Replace defective or worn parts with original spare parts.
- An annual inspection is mandatory.

10.2 Maintenance message

The boiler display will clearly indicate that a service is required at the appropriate time.



See

Manual for the control panel

Use the automatic service message for preventive maintenance, to keep faults to a minimum. The service messages show which service kit must be used. These service kits contain all parts and gaskets that are required for the relevant service. These service kits (A, B or C), put together by Remeha, are available from your spare parts supplier.



Important

- A service message must be followed up within 2 months. Therefore, call your installer as soon as possible.
- If the iSense modulating controller is connected to the boiler, this maintenance message can also be forwarded to the iSense. Consult the manual for the regulator.



Caution

Reset the maintenance message following every service.

10.2.1 Resetting the service messages

A service message on the boiler display must be reset by a qualified installer within two months after the indicated maintenance service has been carried out using the relevant service set and after this has been entered in the checklist. Proceed as follows:

1. Perform the service with the specified service kit (A, B or C).
2. Note the service in the corresponding checklist.



See

Appendix, page 83

3. Reset the service message.



See

Manual for the control panel

10.2.2 Starting a new service interval

For an interim service it is advisable to read out in the boiler service menu what maintenance service should be carried out. Use the indicated Remeha service kits (A, B or C). This service message must be prevented by carrying out a reset. Start the next service interval. Proceed as follows:

1. In the Service menu of the boiler, read which service should be performed.



See

Manual for the control panel

2. Perform the service with the specified service kit (A, B or C).
3. Note the service in the corresponding checklist.



See

Appendix, page 83

4. Reset the service message.
 - ⇒ This prevents this service message from appearing automatically after all.
5. Start the next service interval.

10.3 Standard inspection and maintenance operations



Warning

Always wear safety goggles and a dust mask during cleaning work (involving compressed air).

For a service, always perform the following standard inspection and maintenance operations.



Caution

- Check whether all gaskets have been positioned properly (absolutely flat in the appropriate groove means they are gas tight).
- During the inspection and maintenance operations, water (drops, splashes) must never come into contact with the electrical parts.

10.3.1 Checking the water pressure

1. Check the water pressure.



Important

The water pressure is shown on the display of the control panel.

⇒ The water pressure must be at least 0.8 bar

2. If the water pressure is lower than 0.8 bar, top up the central heating system.

10.3.2 Checking the water quality

1. Fill a clean bottle with some water from the system/boiler from the filling and drain cock.
2. Check the quality of this water sample or have it checked.



See

More information is available in our **Water quality instructions**. This manual forms part of the set of documents supplied with the boiler. Always adhere to the instructions in the aforementioned document.

10.3.3 Checking the ionisation current

1. Check the ionisation current at full load and at low load.
⇒ The value is stable after 1 minute.
2. Clean or replace the ionisation/ignition electrode if the value is lower than 4 µA.



For more information, see

Replacing the ionisation/ignition electrode, page 71

10.3.4 Checking the flue gas discharge/air supply connections

1. Check the flue gas discharge and air supply connections for condition and tightness.

Fig.52 Checking flue gas discharge/air supply connections

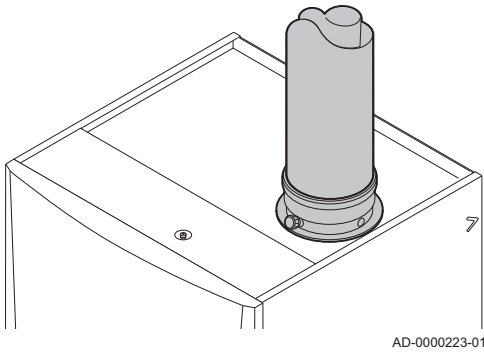

10.3.5 Checking the combustion

Combustion is checked by measuring the O₂/CO₂percentage in the flue gas outlet duct.



For more information, see

Checking/setting combustion, page 45

10.3.6 Checking the air pressure differential switch

■ Checking the air pressure differential switch + side

Fig.53 Check the air pressure differential switch + side

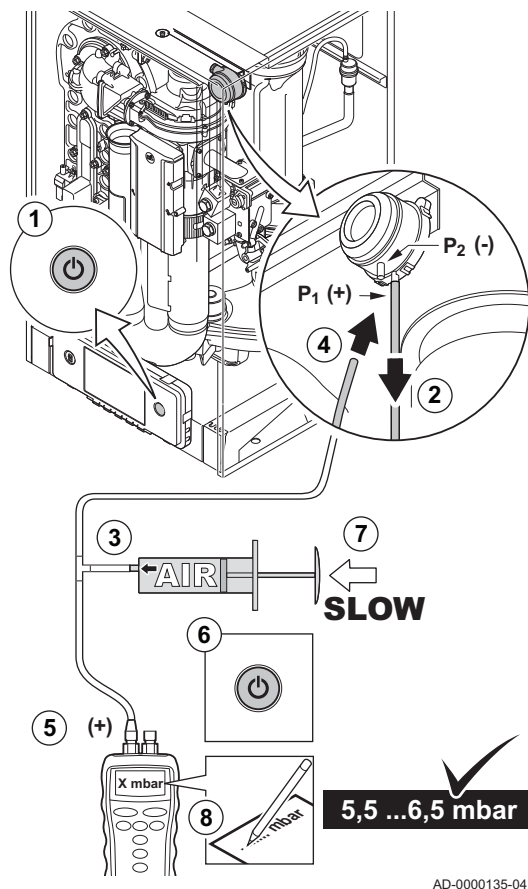

1. Switch off the boiler.
2. Disconnect the silicon hose on the + side (P1) of the air pressure differential switch.
3. Take a large plastic syringe or bellows and connect a T piece with a hose connected.
4. Connect the + side of the air pressure differential switch to one end of the T piece with a hose.
5. On the other end of the T piece, connect the + side of a pressure gauge.
6. Turn on the boiler
7. Push the syringe or bellows in very slowly until the boiler goes into failure mode.
8. Make a note of the pressure indicated by the pressure gauge at that point. A switch pressure of between 5.5 and 6.5 mbar is fine. A lower or higher switch pressure indicates a problem with the air pressure differential switch.
9. After taking a measurement, detach the silicon hose from the T piece on the + side and reconnect the hose that was previously removed.



Caution

Please note: The + side (P1) is the rear connector nipple of the air pressure differential switch.

10. Remove any soiling from all connection points for hoses and the air pressure differential switch.
11. Check the condition and tightness of the hoses of the air pressure differential switch. Replace the hoses if necessary.

■ Checking the air pressure differential switch – side

Fig.54 – side of the air pressure differential switch

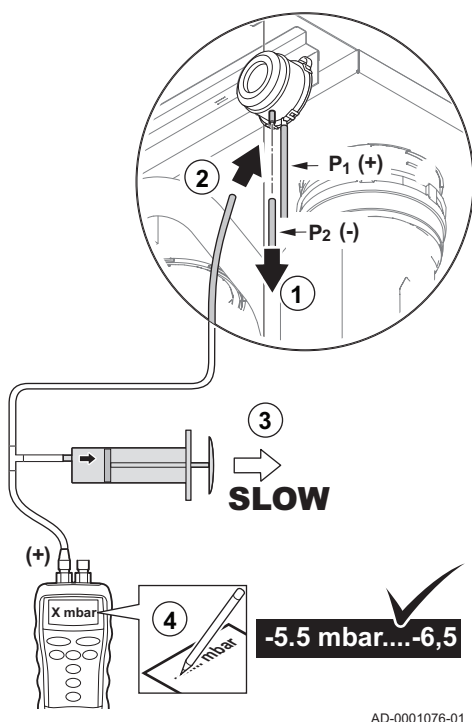

1. Disconnect the short, coloured silicon hose on the – side (P2) of the air pressure differential switch.
2. Connect the – side of the air pressure differential switch to one end of the T piece with a hose.
3. Pull out the syringe until the boiler goes into failure mode.
4. Make a note of the pressure indicated by the pressure gauge at that point.
⇒ A switch pressure of between - 5.5 and - 6.5 mbar is fine. A lower or higher switch pressure indicates a problem with the air pressure differential switch.
5. After taking a measurement, detach the silicon hose from the T-piece on the – side and reconnect the coloured hose that was previously removed.
6. Remove any soiling from all connection points for hoses and the air pressure differential switch.
7. Check the condition and tightness of the hoses of the air pressure differential switch.
⇒ Replace the hoses if necessary.

10.3.7 Checking the automatic air vent

Fig.55 Checking the automatic air vent

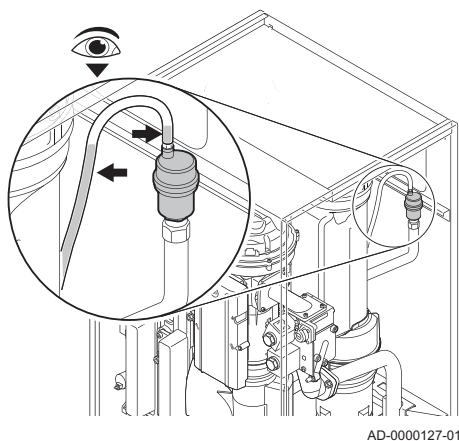

AD-0000127-01

1. Check the hose on top of the air vent.
2. The automatic air vent is leaking if water can be seen in the connected hose.
3. In the event of a leak, replace the air vent.

Fig.56 Checking the burner

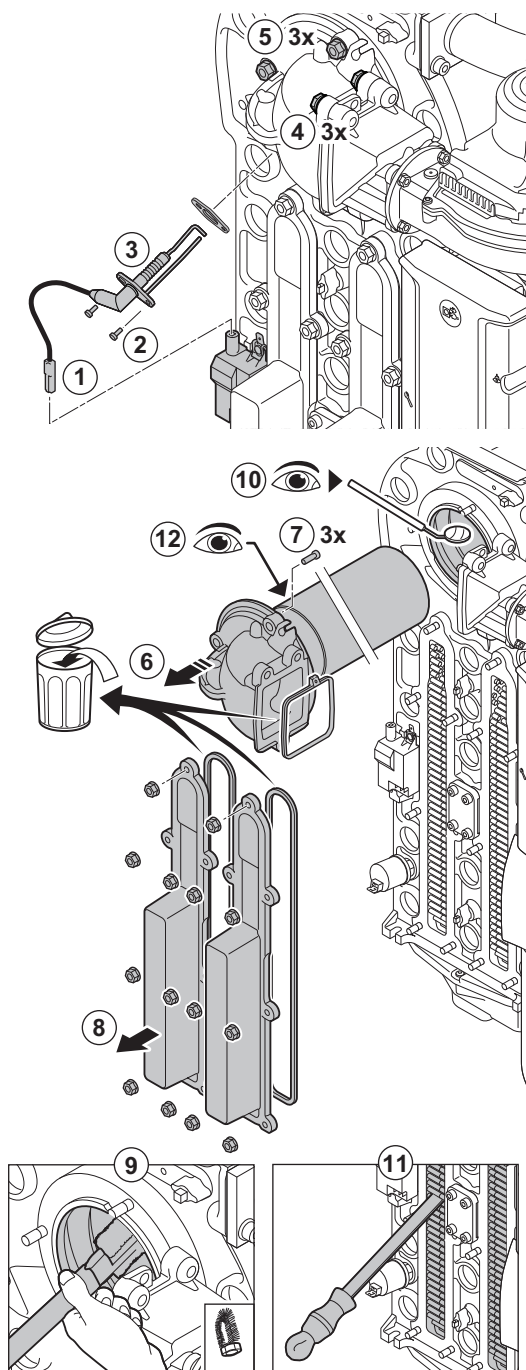

AD-0000128-02

10.3.8 Checking the burner and cleaning the heat exchanger

1. Disconnect the plug of the ionisation/ignition electrode from the ignition transformer.



Caution

The ignition cable is fixed to the ionisation/ignition electrode and therefore may not be removed.

2. Loosen the 2 screws of the ionisation/ignition electrode.
3. Remove the ionisation/ignition electrode from the heat exchanger.
4. Undo the 3 bolts from the adapter on the non-return valve holder (15 Nm torque).
5. Undo the 3 nuts from the adapter on the heat exchanger (15 Nm torque).
6. Carefully remove the adapter with burner from the heat exchanger.
7. Remove the 3 bolts from the burner on the adapter and dismantle the burner.
8. Undo the nuts on the inspection ports (7.5 Nm torque).
⇒ Remove the inspection ports to reach the heat exchanger.
9. Use a vacuum cleaner to clean the top part of the heat exchanger (furnace).
10. Check (e.g. using a mirror) whether any visible contamination has been left behind. If it has, remove it with the vacuum cleaner.
11. Clean the lower section of the heat exchanger with the special cleaning blade (accessory).
12. Burner maintenance is almost never required; it is self-cleaning:
 - 12.1. If necessary, carefully clean the cylinder-shaped burner with compressed air.
 - 12.2. Check that the burner cover of the dismantled burner is free from cracks and/or damage. If not, replace the burner.
13. Reassemble the unit in the reverse order.
14. Open the gas supply and insert the plug in the socket again.



Caution

- Use the specified torques when fitting nuts and bolts.
- Make sure the gaskets are in place when fitting nuts and bolts.

10.3.9 Cleaning the condensate collector

Fig.57 Clean the connection nipple

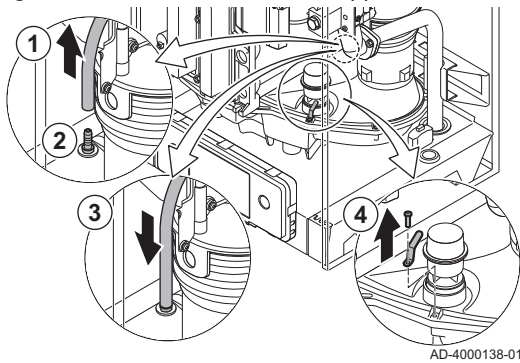

1. Disconnect the silicon hose of the air pressure differential switch from the connection nipple on the condensate collector.
2. Clean the opening of the connection nipple thoroughly (by blowing air or pushing an object through it).
3. Reconnect the silicon hose.
4. Remove the clip that locks the sealing cap.

Fig.58 Clean the condensate collector

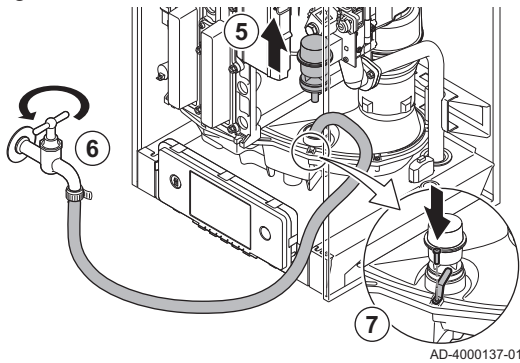

5. Remove the sealing cap from the condensate collector.
6. Rinse the condensate collector thoroughly with a water flow that is as large as possible.

Warning
 During rinsing, avoid penetration of water into the boiler or the control panel.

7. Reassemble in reverse order.

10.3.10 Cleaning the siphon

Fig.59 Cleaning the siphon

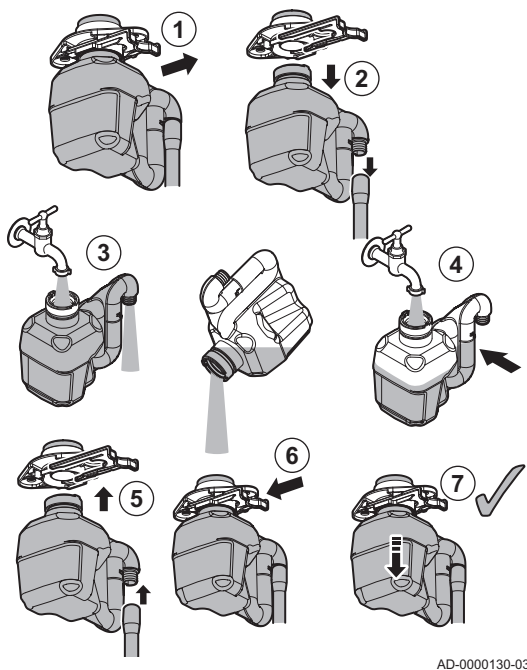

1. Pull the retainer clip of the siphon backwards.
2. Carefully pull the siphon and siphon hose downwards.
3. Clean the siphon with water.
4. Fill the siphon with water up to the mark.
5. Push the siphon firmly into the appropriate opening underneath the boiler and install the siphon hose.
6. Push the retainer clip of the siphon forwards.
7. Check whether the siphon is firmly fitted in the boiler.

Danger
 The siphon must always be filled with water. This prevents flue gases from entering the room.

10.4 Specific maintenance work

Perform the specific maintenance work if this proves to be necessary following the standard inspection and maintenance work. To conduct the specific maintenance work:

Fig.60 Replacing the ionisation/ignition electrode

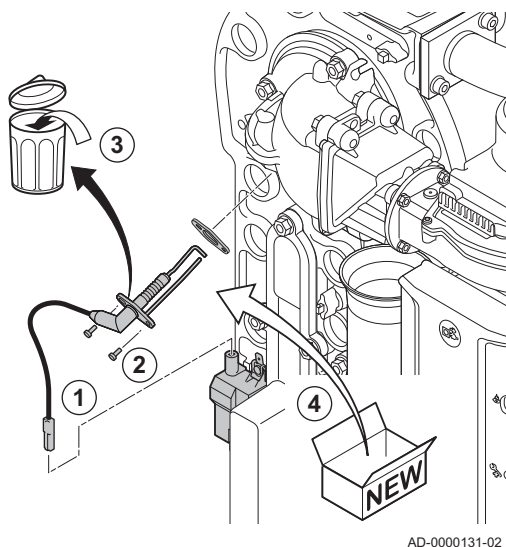

AD-0000131-02

10.4.1 Replacing the ionisation/ignition electrode

The ionisation/ignition electrode must be replaced if:

- The ionisation current is $< 4 \mu\text{A}$.
- The electrode is damaged or worn.
- The electrode is included in the service kit.

1. Remove the plug of the electrode from the ignition transformer.



Important

The ignition cable is fixed to the electrode and therefore may not be removed.

2. Unscrew the two screws on the electrode.
3. Remove the entire component.
4. Fit the new ionisation/ignition electrode.
5. Reassemble the unit in reverse order.

10.4.2 Checking the non-return valve

Check the condition of the non-return valve. Replace the non-return valve if it is defective, there is one in the service kit, or if there are traces of condensation on the inside of the fan. Do this as follows:

1. Undo the 3 bolts from the adapter on the non-return valve holder (15 Nm torque).
2. Undo the 3 nuts from the adapter on the heat exchanger (15 Nm torque).
3. Carefully remove the adapter with burner from the heat exchanger.
4. Remove the 4 bolts from the fan and remove the non-return valve holder (5.5 Nm torque).
5. Check whether traces of condensation are visible on the inside of the fan. Replace the non-return valve if there are visible traces of condensation.
6. Inspect the non-return valve and replace it in the event of a defect or damage.
7. When replacing the non-return valve, loosen the fixing screw of the non-return valve and remove it.
8. Reassemble in the reverse order.



Caution

- Use the specified torques when fitting nuts and bolts.
- Make sure the gaskets are in place when fitting nuts and bolts.

Fig.61 Checking the non-return valve

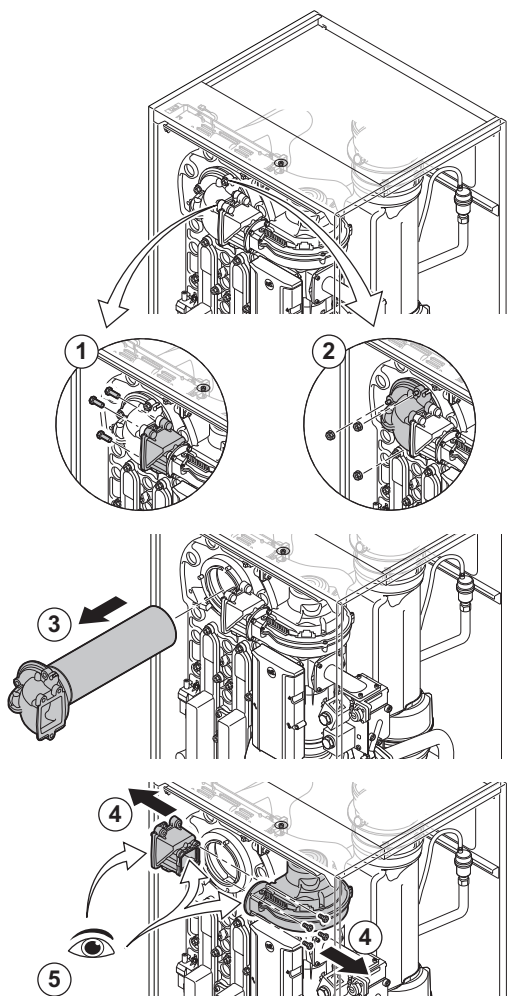

AD-0000134-02

Fig.62 Putting the boiler into operation

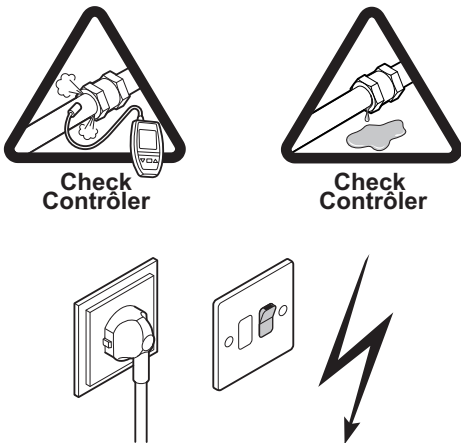

AD-0000132-01

10.4.3 Reassembling the boiler

1. Fit all removed parts in the reverse order.
2. During inspection or maintenance work, always replace all gaskets of the disassembled parts.
3. Check the tightness of the gas and water connections.
4. Put the boiler back into operation.

11 Disposal

11.1 Disposal and recycling

Fig.63

**Important**

Removal and disposal of the boiler must be carried out by a qualified person in accordance with local and national regulations.

To remove the boiler, proceed as follows:

1. Cut the power supply to the boiler.
2. Shut off the gas supply.
3. Shut off the water supply.
4. Drain the system.
5. Remove the siphon.
6. Remove the air supply/flue gas outlet pipes.
7. Disconnect all pipes on the boiler.
8. Remove the boiler.

12 Troubleshooting

12.1 Error codes

The boiler is fitted with an electronic regulation and control unit. The heart of the control is a **e-Smart** microprocessor, which controls and also protects the boiler. In the event of an error, a corresponding code is displayed.

Tab.61 Error codes are displayed at three different levels

Code	Type	Description
A00.00 ⁽¹⁾	Warning	The boiler continues to operate but the cause of the warning must be investigated. A warning can change into a blocking or lock-out.
H00.00 ⁽¹⁾	Blocking	The boiler starts up again automatically when the cause of the blocking has been rectified. A blocking can become a lock-out.
E00.00 ⁽¹⁾	Lock out	The boiler starts up again only when the cause of the lock-out has been rectified and reset manually.

(1) The first letter indicates the type of error.

The meaning of the code can be found in the various error code tables.



Important

The error code is needed to find the cause of the error quickly and correctly and for any support from Remeha.

12.1.1 Display of error codes

Fig.64 HMI T-control

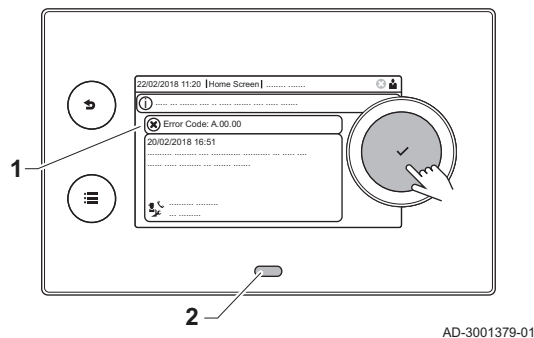

When an error occurs in the installation, the control panel shows:

- 1 The display will show a corresponding code and message.
- 2 The status LED of the control panel will show:
 - Continuous green = Normal operation
 - Flashing green = Warning
 - Continuous red = Blocking
 - Flashing red = Lock out

1. Press and hold the ✓ button to reset the boiler.
 - ⇒ The boiler starts up again only when the cause of the error has been rectified.
2. If the error code reappears, correct the problem by following the instructions in the error code tables.
 - ⇒ The error code remains visible until the problem is solved.
3. Note the error code when the problem cannot be solved.

12.1.2 Warning

Tab.62 Warning codes

Code	Display text	Description	Solution
A.01.21	Dhw Temp GradLevel3	Maximum Dhw Temperature Gradient Level3 Exceeded	Temperature warning: <ul style="list-style-type: none"> • Check the flow.
A.02.06	Water Press Warning	Water Pressure Warning active	Water pressure warning: <ul style="list-style-type: none"> • Water pressure too low; check the water pressure
A.02.18	OBd Error	Object Dictionary Error	Configuration error: <ul style="list-style-type: none"> • Reset CN1 and CN2 <div style="display: flex; align-items: center;"> <p>See The data plate for the CN1 and CN2 values.</p> </div>

Code	Display text	Description	Solution
A.02.37	Uncritic device lost	Uncritical device has been disconnected	SCB not found: <ul style="list-style-type: none"> • Bad connection: check the wiring and connectors • Faulty SCB: Replace SCB
A.02.45	Full Can Conn Matrix	Full Can Connection Matrix	SCB not found: <ul style="list-style-type: none"> • Carry out an auto-detect
A.02.46	Full Can Device Adm	Full Can Device Administration	SCB not found: <ul style="list-style-type: none"> • Carry out an auto-detect
A.02.49	Failed Init Node	Failed Initialising Node	SCB not found: <ul style="list-style-type: none"> • Carry out an auto-detect
A.02.55	Inval or miss SerNR	Invalid or missing device serial number	Contact your supplier.
A.03.17	Safety check	Periodically safety check ongoing	Safety check procedure active: <ul style="list-style-type: none"> • No action

12.1.3 Blocking

Tab.63 Blocking codes

Code	Display text	Description	Solution
H.00.36	T 2nd Return Open	Second return temperature sensor is either removed or measures a temperature below range	Second return temperature sensor open: <ul style="list-style-type: none"> • Bad connection: check the wiring and connectors. • Incorrectly fitted sensor: check that the sensor has been correctly fitted. • Faulty sensor: replace the sensor.
H.00.37	T 2nd Return Closed	Second return temperature sensor is either shorted or measures a temperature above range	Second return temperature sensor short-circuited: <ul style="list-style-type: none"> • Bad connection: check the wiring and connectors. • Incorrectly fitted sensor: check that the sensor has been correctly fitted. • Faulty sensor: replace the sensor.
H.01.00	Comm Error	Communication Error occurred	Communication error with the security kernel: <ul style="list-style-type: none"> • Restart the boiler • Replace the CU-GH
H.01.06	Max Delta TH-TF	Maximum difference between heat exchanger temperature and flow temperature	Maximum difference between heat exchanger and flow temperature exceeded: <ul style="list-style-type: none"> • No flow or insufficient flow: <ul style="list-style-type: none"> - Check the circulation (direction, pump, valves). - Check the water pressure. - Check the cleanliness of the heat exchanger. - Check that the installation has been de-aired. - Check water quality according to supplier's specifications. • Sensor error: <ul style="list-style-type: none"> - Check that the sensors are operating correctly. - Check that the sensor has been fitted properly.

Code	Display text	Description	Solution
H.01.07	Max Delta TH-TR	Maximum difference between heat exchanger temperature and return temperature	<p>Maximum difference between heat exchanger and return temperature exceeded:</p> <ul style="list-style-type: none"> • No flow or insufficient flow: <ul style="list-style-type: none"> - Check the circulation (direction, pump, valves). - Check the water pressure. - Check the cleanliness of the heat exchanger. - Check that the installation has been correctly vented to remove air. • Sensor error: <ul style="list-style-type: none"> - Check that the sensors are operating correctly. - Check that the sensor has been fitted properly.
H.01.08	CH Temp Grad. Level3	Maximum CH temperature gradient level3 exceeded	<p>Maximum heat exchanger temperature increase has been exceeded:</p> <ul style="list-style-type: none"> • No flow or insufficient flow: <ul style="list-style-type: none"> - Check the circulation (direction, pump, valves) - Check the water pressure - Check the cleanliness of the heat exchanger - Check that the central heating system has been correctly vented to remove air • Sensor error: <ul style="list-style-type: none"> - Check that the sensors are operating correctly - Check that the sensor has been fitted properly
H.01.09	Gas Pressure Switch	Gas Pressure Switch	<p>Gas pressure too low:</p> <ul style="list-style-type: none"> • No flow or insufficient flow: <ul style="list-style-type: none"> - Make sure that the gas valve is fully opened - Check the gas supply pressure - If a gas filter is present: Make sure that the filter is clean • Wrong setting on the gas pressure switch: <ul style="list-style-type: none"> - Make sure that the switch has been fitted properly - Replace the switch if necessary
H.01.13	Max THeat Ex	Heat Exchanger temperature has exceeded the maximum operating value	<p>Maximum heat exchanger temperature exceeded:</p> <ul style="list-style-type: none"> • Check the circulation (direction, pump, valves). • Check the water pressure. • Check that the sensors are operating correctly. • Check that the sensor has been fitted properly. • Check the cleanliness of the heat exchanger. • Check that the central heating system has been correctly vented to remove air.
H.01.14	Max Tflow	Flow temperature has exceeded the maximum operating value	<p>Flow temperature sensor above normal range:</p> <ul style="list-style-type: none"> • Bad connection: check the wiring and connectors • No flow or insufficient flow: <ul style="list-style-type: none"> - Check the circulation (direction, pump, valves) - Check the water pressure - Check the cleanliness of the heat exchanger
H.01.15	Max Tflue Gas	Flue gas temperature has exceeded the maximum operating value	<p>Maximum flue gas temperature exceeded:</p> <ul style="list-style-type: none"> • Check the flue gas outlet system • Check the heat exchanger to ensure that the flue gas side is not clogged • Faulty sensor: replace the sensor

Code	Display text	Description	Solution
H.02.00	Reset In Progress	Reset In Progress	Reset procedure active: <ul style="list-style-type: none"> • No action
H.02.02	Wait Config Number	Waiting For Configuration Number	Configuration error or unknown configuration number: <ul style="list-style-type: none"> • Reset CN1 and CN2
H.02.03	Conf Error	Configuration Error	Configuration error or unknown configuration number: <ul style="list-style-type: none"> • Reset CN1 and CN2
H.02.05	CSU CU mismatch	CSU does not match CU type	Configuration error: <ul style="list-style-type: none"> • Reset CN1 and CN2
H.02.09	Partial block	Partial blocking of the device recognized	Blocking input active or frost protection active: <ul style="list-style-type: none"> • External cause: remove external cause • Wrong parameter set: check the parameters • Bad connection: check the connection
H.02.10	Full Block	Full blocking of the device recognized	Blocking input is active (without frost protection): <ul style="list-style-type: none"> • External cause: remove external cause • Wrong parameter set: check the parameters • Bad connection: check the connection
H.02.12	Release Signal	Release Signal input of the Control Unit from device external environment	Waiting time release signal has elapsed: <ul style="list-style-type: none"> • External cause: remove external cause • Wrong parameter set: check the parameters • Bad connection: check the connection
H.02.18	OBD Error	Object Dictionary Error	<ul style="list-style-type: none"> • Reset CN1 and CN2  See The data plate for the CN1 and CN2 values.
H.02.36	Funct device lost	Functional device has been disconnected	Communication error with the SCB PCB: <ul style="list-style-type: none"> • Bad connection with BUS: check the wiring. • No PCB: reconnect PCB or retrieve from memory using auto-detect.
H.02.48	Funct Gr Conf Fault	Function Group Configuration Fault	SCB not found: <ul style="list-style-type: none"> • Carry out an auto-detect
H.02.50	Funct Gr Comm Err	Function Group Communication Error	SCB not found: <ul style="list-style-type: none"> • Carry out an auto-detect.
H.03.00	Parameter Error	Safety parameters level 2, 3, 4 are not correct or missing	Parameter error: security kernel <ul style="list-style-type: none"> • Restart the boiler • Replace the CU-GH
H.03.01	CU to GVC data error	No valid data from CU to GVC received	Communication error with the CU-GH: <ul style="list-style-type: none"> • Restart the boiler
H.03.02	Flame loss detected	Measured ionisation current is below limit	No flame during operation: <ul style="list-style-type: none"> • No ionisation current: <ul style="list-style-type: none"> - Vent the gas supply to remove air - Check that the gas valve is fully opened - Check the gas supply pressure - Check the operation and setting of the gas valve unit - Check that the air supply inlet and flue gas outlet are not blocked - Check that there is no recirculation of flue gases
H.03.05	Internal blocking	Gas Valve Control internal blocking occurred	Security kernel error: <ul style="list-style-type: none"> • Restart the boiler • Replace the CU-GH

12.1.4 Locking

Tab.64 Locking codes

Code	Display text	Description	Solution
E.00.00	TFlow Open	Flow temperature sensor is either removed or measures a temperature below range	Zone flow temperature sensor open: <ul style="list-style-type: none"> • Sensor is not present. • Bad connection: check the wiring and connectors. • Incorrectly fitted sensor: check that the sensor has been correctly fitted. • Faulty sensor: replace the sensor.
E.00.01	TFlow Closed	Flow temperature sensor is either shorted or measures a temperature above range	Zone flow temperature sensor short-circuited: <ul style="list-style-type: none"> • Sensor is not present. • Bad connection: check the wiring and connectors. • Incorrectly fitted sensor: check that the sensor has been correctly fitted. • Faulty sensor: replace the sensor.
E.00.04	TReturn Open	Return temperature sensor is either removed or measures a temperature below range	Return temperature sensor open: <ul style="list-style-type: none"> • Bad connection: check the wiring and connectors • Incorrectly fitted sensor: check that the sensor has been correctly fitted • Faulty sensor: replace the sensor
E.00.05	TReturn Closed	Return temperature sensor is either shorted or measures a temperature above range	Return temperature sensor short-circuited: <ul style="list-style-type: none"> • Bad connection: check the wiring and connectors • Incorrectly fitted sensor: check that the sensor has been correctly fitted • Faulty sensor: replace the sensor
E.00.08	THeat Ex Open	Heat exchanger temperature sensor is either removed or measures a temperature below range	Heat exchanger temperature sensor open: <ul style="list-style-type: none"> • Bad connection: check the wiring and connectors. • Incorrectly fitted sensor: check that the sensor has been correctly fitted. • Faulty sensor: replace the sensor.
E.00.09	THeat Ex Closed	Heat exchanger temperature sensor is either shorted or measures a temperature above range	Heat exchanger temperature sensor short-circuited: <ul style="list-style-type: none"> • Bad connection: check the wiring and connectors. • Incorrectly fitted sensor: check that the sensor has been correctly fitted. • Faulty sensor: replace the sensor.
E.00.20	TFlue Gas Open	Flue gas temperature sensor is either removed or measures a temperature below range	Open circuit in flue gas sensor: <ul style="list-style-type: none"> • Bad connection: check the wiring and connectors. • Incorrectly fitted sensor: check that the sensor has been correctly fitted. • Faulty sensor: replace the sensor.
E.00.21	TFlue Gas Closed	Flue gas temperature sensor is either shorted or measures a temperature above range	Flue gas sensor short-circuited: <ul style="list-style-type: none"> • Bad connection: check the wiring and connectors. • Incorrectly fitted sensor: check that the sensor has been correctly fitted. • Faulty sensor: replace the sensor.

Code	Display text	Description	Solution
E.00.40	WaterPressureOpen	Water pressure sensor is either removed or measures a temperature below range	Hydraulic pressure sensor open: <ul style="list-style-type: none"> • Bad connection: check the wiring and connectors. • Incorrectly fitted sensor: check that the sensor has been correctly fitted. • Faulty sensor: replace the sensor.
E.00.41	WaterPressureClosed	Water pressure sensor is either shorted or measures a temperature above range	Hydraulic pressure sensor short-circuited: <ul style="list-style-type: none"> • Bad connection: check the wiring and connectors. • Incorrectly fitted sensor: check that the sensor has been correctly fitted. • Faulty sensor: replace the sensor.
E.01.04	5x Flame Loss Error	5x Error of unintended Flame Loss occurrence	Flame loss occurs 5 times: <ul style="list-style-type: none"> • Vent the gas supply to remove air • Check that the gas valve is fully opened • Check the gas supply pressure • Check the operation and setting of the gas valve unit • Check that the air supply inlet and flue gas outlet are not blocked • Check that there is no recirculation of flue gases
E.01.12	Return Higher Flow	Return temperature has a higher temperature value than the flow temperature	Flow and return reversed: <ul style="list-style-type: none"> • Bad connection: check the wiring and connectors • Water circulation in wrong direction: check the circulation (direction, pump, valves) • Incorrectly fitted sensor: check that the sensor has been correctly fitted • Malfunctioning sensor: check the Ohmic value of the sensor • Faulty sensor: replace the sensor
E.02.04	Parameter Error	Parameter Error	Configuration error: <ul style="list-style-type: none"> • Reset CN1 and CN2  See The data plate for the CN1 and CN2 values.
E.02.13	Blocking Input	Blocking Input of the Control Unit from device external environment	Blocking input is active: <ul style="list-style-type: none"> • External cause: remove external cause • Wrong parameter set: check the parameters
E.02.15	Ext CSU Timeout	External CSU Timeout	CSU time out: <ul style="list-style-type: none"> • Bad connection: check the wiring and connectors • Faulty CSU: Replace CSU
E.02.17	GVC CommTimeout	Gas Valve Control unit communication has exceeded feedback time	Communication error with the security kernel: <ul style="list-style-type: none"> • Restart the boiler • Replace the CU-GH
E.02.35	Safety device lost	Safety critical device has been disconnected	Communication fault <ul style="list-style-type: none"> • Carry out an auto-detect
E.02.47	Failed Conn Funct Gr	Failed Connecting Function Groups	Function group not found: <ul style="list-style-type: none"> • Carry out an auto-detect • Restart the boiler • Replace the CU-GH
E.02.48	Funct Gr Conf Fault	Function Group Configuration Fault	SCB not found: <ul style="list-style-type: none"> • Carry out an auto-detect.
E.02.51	Gvc Parameter Error	Parameter error from the Gvc	-

Code	Display text	Description	Solution
E.02.52	Gvc Burner Prof Err	Gvc Burner Profile Error	-
E.04.00	Parameter error	Safety parameters Level 5 are not correct or missing	Replace the CU-GH.
E.04.01	TFlow Closed	Flow temperature sensor is either shorted or measuring a temperature above range	Flow temperature sensor short circuited: <ul style="list-style-type: none"> • Bad connection: check the wiring and connectors • Incorrectly fitted sensor: check that the sensor has been correctly fitted • Faulty sensor: replace the sensor
E.04.02	TFlow Open	Flow temperature sensor is either removed or measuring a temperature below range	Flow temperature sensor open: <ul style="list-style-type: none"> • Bad connection: check the wiring and connectors • Faulty sensor: replace the sensor
E.04.03	Max Flow temp	Measured flow temperature above safety limit	No flow or insufficient flow: <ul style="list-style-type: none"> • Check the circulation (direction, pump, valves) • Check the water pressure • Check the cleanliness of the heat exchanger
E.04.04	TFlue Closed	Flue temperature sensor is either shorted or measuring a temperature above range	Flue gas temperature sensor short-circuited: <ul style="list-style-type: none"> • Bad connection: check the wiring and connectors • Incorrectly fitted sensor: check that the sensor has been correctly fitted • Faulty sensor: replace the sensor
E.04.05	TFlue Open	Flue temperature sensor is either removed or measuring a temperature below range	Flue gas temperature sensor open: <ul style="list-style-type: none"> • Bad connection: check the wiring and connectors • Incorrectly fitted sensor: check that the sensor has been correctly fitted • Faulty sensor: replace the sensor
E.04.06	Max Flue temp	Measured flue temperature above limit	-
E.04.07	TFlow Sensor	Deviation in flow sensor 1 and flow sensor 2 detected	Flow temperature sensor deviation: <ul style="list-style-type: none"> • Bad connection: check the connection • Faulty sensor: replace the sensor
E.04.08	Safety input	Safety input is open	Air pressure differential switch activated: <ul style="list-style-type: none"> • Bad connection: check the wiring and connectors • Pressure in flue gas duct is or was too high: <ul style="list-style-type: none"> - Non-return valve does not open - Siphon blocked or empty - Check that the air supply inlet and flue gas outlet are not blocked - Check the cleanliness of the heat exchanger
E.04.09	TFlue Sensor	Deviation in flue sensor 1 and flue sensor 2 detected	Flue gas temperature sensor deviation: <ul style="list-style-type: none"> • Bad connection: check the connection • Faulty sensor: replace the sensor

Code	Display text	Description	Solution
E.04.10	Unsuccessful start	5 Unsuccessful burners starts detected	<p>Five failed burner starts:</p> <ul style="list-style-type: none"> • No ignition spark: <ul style="list-style-type: none"> - Check the wiring between the CU-GH and the ignition transformer - Check the ionisation/ignition electrode - Check breakdown to earth - Check the condition of the burner cover - Check the earthing - Replace the CU-GH • Ignition spark but no flame: <ul style="list-style-type: none"> - Vent the gas pipes to remove air - Check that the air supply inlet and flue gas outlet are not blocked - Check that the gas valve is fully opened - Check the gas supply pressure - Check the operation and setting of the gas valve unit - Check the wiring on the gas valve unit - Replace the CU-GH • Flame present, but ionisation has failed or is inadequate: <ul style="list-style-type: none"> - Check that the gas valve is fully opened - Check the gas supply pressure - Check the ionisation/ignition electrode - Check the earthing - Check the wiring on the ionisation/ignition electrode.
E.04.11	VPS	VPS Gas Valve proving failed	<p>Gas leakage control fault:</p> <ul style="list-style-type: none"> • Bad connection: check the wiring and connectors • Gas leakage control VPS faulty: Replace the valve proving system (VPS) • Gas valve unit faulty: Replace the gas valve unit
E.04.12	False flame	False flame detected before burner start	<p>False flame signal:</p> <ul style="list-style-type: none"> • The burner remains very hot: Set the O₂ • Ionisation current measured but no flame should be present: check the ionisation/ignition electrode • Faulty gas valve: replace the gas valve • Faulty ignition transformer: replace the ignition transformer
E.04.13	Fan	Fan speed has exceeded normal operating range	<p>Fan fault:</p> <ul style="list-style-type: none"> • Bad connection: check the wiring and connectors. • Fan operates when it should not be operating: check for excessive chimney draught • Faulty fan: replace the fan
E.04.14	Combustion Error	The burner temperature and setpoint differ more than 60s regarding GVC configuration	-
E.04.15	FlueGas Pipe Blocked	The flue gas pipe is blocked	<p>Flue gas outlet is blocked:</p> <ul style="list-style-type: none"> • Check that the flue gas outlet is not blocked • Restart the boiler
E.04.17	GasValve Driver Err.	The driver for the gas valve is broken	<p>Gas valve unit fault:</p> <ul style="list-style-type: none"> • Bad connection: check the wiring and connectors • Faulty gas valve unit: Replace the gas valve unit

Code	Display text	Description	Solution
E.04.18	Min Temp Flow Error	The flow temperature is less than the minimum defined by the GVC parameter	-
E.04.19	Mass flow sensor	Mass Flow Sensor Communciation	-
E.04.20	Mass flow sensor	MassFlowSensor Deviation	-
E.04.21	Burner temperature	Deviation in burner sensor 1 and burner sensor 2 detected	-
E.04.23	Internal Error	Gas Valve Control internal locking	<ul style="list-style-type: none"> Restart the boiler Replace the CU-GH
E.04.24	No Gas Family	No Gas Family determined during gas family detection mode	-
E.04.250	Internal error	Gas valve relay error detected	Internal error: <ul style="list-style-type: none"> Replace the PCB.
E.04.254	Unknown	Unknown	Unknown error: <ul style="list-style-type: none"> Replace the PCB.

12.2 Error history

The control panel includes an error memory in which is stored a history of the last 32 errors. Details of the boiler when the error occurred can be read out. For example;

- status
- sub-status
- flow temperature
- return temperature

These details and others can contribute to the error solution.

12.2.1 Reading out and clearing the error memory

The error memory stores the details of the most recent errors.

1. Select the tile [🔔].
2. Press the ✓ button to confirm the selection.
3. Use the rotary knob to select code: **0012**
4. Press the ✓ button to confirm the selection.
 - ⇒ When the installer level is enabled, the status of the tile [🔔] changes from **Off** into **On**.
5. Press the ☰ button.
6. Use the rotary knob to select **Error History**.
7. Press the ✓ button to confirm the selection.
 - ⇒ A list up to 32 most recent errors is displayed with the error code, a short description and the date.
8. Use the rotary knob to select the error code you want to investigate.
9. Press the ✓ button to confirm the selection.
 - ⇒ The display shows an explanation of the error code and several details of the boiler when the error occurred.
10. To clear the error memory, press and hold the ✓ button.

Fig.65 Installer level

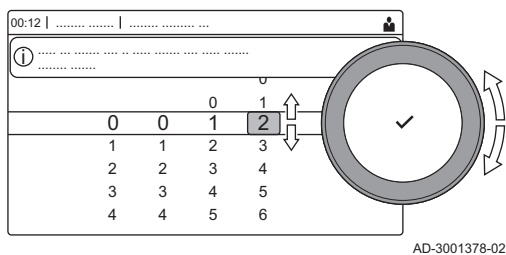
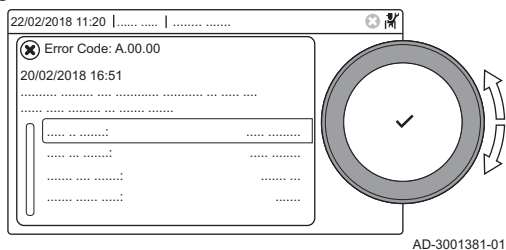

Fig.66 Error details



13 Appendix

13.1 ErP information

13.1.1 Product fiche

Tab.65 Product fiche

Remeha - Quinta Ace		135	160
Seasonal space heating energy efficiency class		-	-
Rated heat output (<i>Prated or Psup</i>)	kW	128	152
Seasonal space heating energy efficiency	%	-	-
Annual energy consumption	GJ	-	-
Sound power level L_{WA} indoors	dB	68	68



See

For specific precautions in relation to assembly, installation and maintenance: Safety, page 6

13.2 EC declaration of conformity

The unit complies with the standard type described in the EC declaration of conformity. It has been manufactured and commissioned in accordance with European directives.

The original declaration of conformity is available from the manufacturer.

13.3 Checklist for commissioning

Tab.66 Checklist

No.	Commissioning tasks	Confirmation
1	Fill the system with water and check the water pressure	
2	Fill the siphon with water	
3	Vent the central heating system	
4	Check water-side connections for tightness	
5	Check the gas supply pressure	
6	Check the capacity of the gas meter	
7	Check the gas tightness of the connections and gas pipes	
8	Vent the gas supply pipe	
9	Check the electrical connections	
10	Check the flue gas outlet/air supply connections	
11	Checking the function and operational status of the boiler	
12	Check the air-gas ratio	
13	Remove the measuring equipment and close the measuring points	
14	Correctly fit the front housing of the boiler	
15	Set the room thermostat or the control	
16	Instruct the user and hand over the necessary documents	
17	Complete the guarantee card online	
18	Confirm the commissioning	
	Date	dd-mm-yy
	.	
	.	
	Company name, signature of engineer	
	.	
	.	

13.4 Checklist for annual maintenance

Tab.67 Checklist for annual maintenance

No.	Inspection and/or servicing work	Confirmation		
1	Check the water pressure			
2	Check the water quality			
3	Check the ionisation current			
4	Check the air supply/flue gas discharge connections			
5	Check the combustion (O ₂ /CO ₂) at full load and low load			
6	Checking the automatic air vent			
7	Checking the burner and cleaning the heat exchanger			
9	Cleaning the siphon			
10	Assembly of the boiler (replace removed gaskets)			
11	Boiler inspected visually			
12	Maintenance kit A, B or C used			
13	Maintenance message reset			
14	Extra maintenance work that was undertaken			
	·			
	·			
	·			
	·			
	·			
15	Confirmation of inspection			
	Date	dd-mm-yy	dd-mm-yy	dd-mm-yy
	·			
15	Company name, signature of engineer			
	·			
	·			

Original instructions - © Copyright

All technical and technological information contained in these technical instructions, as well as any drawings and technical descriptions supplied, remain our property and shall not be multiplied without our prior consent in writing. Subject to alterations.

T +44 (0)118 978 3434
F +44 (0)118 978 6977
E boilers@remeha.co.uk

Remeha Commercial UK
Innovations House
3 Oaklands Business Centre
Oaklands Park
RG41 2FD Wokingham

