



OPERATING AND SERVICE MANUAL

MODEL 203A  
VARIABLE PHASE  
FUNCTION GENERATOR

SERIALS PREFIXED: 1201 J

Copyright Hewlett-Packard Company 1964  
P. O. Box 301, Loveland, Colorado, 80537 U. S. A.

PART NO. 00203-99002

## CERTIFICATION

*The Hewlett-Packard Company certifies that this instrument was thoroughly tested and inspected and found to meet its published specifications when it was shipped from the factory. The Hewlett-Packard Company further certifies that its calibration measurements are traceable to the U.S. National Bureau of Standards to the extent allowed by the Bureau's calibration facility.*

## WARRANTY AND ASSISTANCE

All Hewlett-Packard products are warranted against defects in materials and workmanship. This warranty applies for one year from the date of delivery, or, in the case of certain major components listed in the operating manual, for the specified period. We will repair or replace products which prove to be defective during the warranty period provided they are returned to Hewlett-Packard. No other warranty is expressed or implied. We are not liable for consequential damages.

Service contracts or customer assistance agreements are available for Hewlett-Packard products that require maintenance and repair on-site.

For any assistance, contact your nearest Hewlett-Packard Sales and Service Office. Addresses are provided at the back of this manual.

**SECTION I GENERAL INFORMATION**

**SECTION II INSTALLATION**

**SECTION III OPERATING INFORMATION**

**SECTION IV PRINCIPLES OF OPERATION**

**SECTION V MAINTENANCE**

**SECTION VI REPLACEABLE PARTS**

Section	Page
I GENERAL INFORMATION . . . . .	1-1
1-1. Description . . . . .	1-1
1-5. Options Available . . . . .	1-1
1-7. Applications . . . . .	1-1
1-9. Instrument Identification . . . . .	1-1

Section	Page
II INSTALLATION . . . . .	2-1
2-1. Inspection . . . . .	2-1
2-3. Power Requirements . . . . .	2-1
2-5. Three-Conductor Power Cable . . . . .	2-1
2-8. Installation . . . . .	2-1
2-10. Rack/Bench Installation . . . . .	2-1
2-12. Repackaging for Shipment . . . . .	2-1

Section	Page
III OPERATION . . . . .	3-1
3-1. Introduction . . . . .	3-1
3-3. Controls and Indicators . . . . .	3-1
3-5. Operating Instructions . . . . .	3-1
3-7. Calibration for 60 Cycle Line Frequency . . . . .	3-1
3-9. Calibration for Line Frequencies Other Than 60 Cycles . . . . .	3-1

Section	Page
IV PRINCIPLES OF OPERATION . . . . .	4-1
4-1. Overall Description . . . . .	4-1
4-5. Crystal Oscillator and Divider Assembly (A1) . . . . .	4-1
4-7. Crystal Oscillator . . . . .	4-1
4-9. 9:1 Frequency Divider . . . . .	4-1
4-16. Variable Phase Shifter Assembly . . . . .	4-1
4-18. RF Amplifiers (A2) . . . . .	4-1
4-20. Variable Phase Channel RF Amplifier . . . . .	4-2
4-23. Reference Phase Channel RF Amplifier . . . . .	4-2
4-25. Variable Frequency Oscillator (A10) . . . . .	4-2
4-27. Decade Modules (A11-A16) . . . . .	4-2
4-29. Decade Module (A11) . . . . .	4-2
4-31. Decade Modules, A12 through A16. . . . .	4-3
4-33. Modulator Assembly, A3 . . . . .	4-3
4-35. Modulator Driver Amplifier . . . . .	4-3
4-37. Reference Phase Channel. Modulator . . . . .	4-3
4-40. Variable Phase Channel Modulator . . . . .	4-3
4-42. DC Amplifier Assemblies A6 and A7. . . . .	4-3
4-44. Reference Phase Channel DC Amplifier Assembly . . . . .	4-3

Table	Page
1-1. Specifications . . . . .	1-0
2-1. Checks for Incoming Inspection (Specifications) . . . . .	2-2
5-1. Required Test Equipment . . . . .	5-1
5-2. Frequency Dial Calibration . . . . .	5-3
5-3. Phase Lag Check . . . . .	5-6

Section	Page
IV PRINCIPLES OF OPERATION (Cont'd)	
4-46. Variable Phase Channel DC Amplifier Assembly . . . . .	4-3
4-48. Square Wave Amplifier Assemblies A8 and A9. . . . .	4-3
4-50. Reference Phase Channel Square Wave Generator . . . . .	4-3
4-52. Variable Phase Channel Square Wave Generator . . . . .	4-4
4-54. DC Power Supply, A21, A22 . . . . .	4-4
4-56. Calibrate Feature . . . . .	4-4

Section	Page
V MAINTENANCE . . . . .	5-1
5-1. Required Test Equipment . . . . .	5-1
5-3. Performance Checks . . . . .	5-1
5-5. Frequency Dial Calibration . . . . .	5-1
5-6. Frequency Response . . . . .	5-2
5-7. Sine Wave Check . . . . .	5-3
5-8. Square Wave Check . . . . .	5-5
5-9. Phase Lag Check . . . . .	5-5
5-10. Instrument Cover Removal . . . . .	5-6
5-12. Adjustments . . . . .	5-6
5-14. Power Supply A22 Adjustments . . . . .	5-6
5-15. 4.995 Mc Oscillator and 9:1 Divider (A1) Adjustment . . . . .	5-6
5-16. Adjustable Phase Shifter (A25) Adjustment . . . . .	5-7
5-17. RF Amplifier Adjustment (A2) . . . . .	5-7
5-18. Decade Module (A11) Adjustment . . . . .	5-7
5-19. Decade Module (A12-A16) Adjustments . . . . .	5-8
5-20. Frequency Dial Adjustment . . . . .	5-8
5-21. Modulator (A3) Adjustment . . . . .	5-8
5-22. Distortion . . . . .	5-8
5-23. Frequency Response . . . . .	5-8
5-24. Phase Lag Dial . . . . .	5-9
5-25. Square Wave (A8 and A9) Adjustment . . . . .	5-9
5-26. Troubleshooting . . . . .	5-9
5-28. Printed Circuit Board Repair . . . . .	5-9

Section	Page
VI REPLACEABLE PARTS . . . . .	6-1
6-1. Introduction . . . . .	6-1
6-4. Ordering Information . . . . .	6-1
6-6. Non-Listed Parts . . . . .	6-1

APPENDIX

A CODE LIST OF MANUFACTURERS
B SALES AND SERVICE OFFICES
C MANUAL BACKDATING CHANGES

Table	Page
5-4. Module A11-A14 Adjustment . . . . .	5-8
5-5. Purpose of Factory Selected Values . . . . .	5-10
5-6. Troubleshooting Summary . . . . .	5-11
6-1. Index by Reference Designator . . . . .	6-2
6-2. Replaceable Parts . . . . .	6-12

Figure	Page	Figure	Page
1-1. Model 203A Variable Phase Function Generator . . . . .	1-0	5-13b. Decade Module Assy A11 thru A16 - Component Location . . . . .	5-21/5-22
3-1. Front Panel Description . . . . .	3-2	5-14. VFO Assy A10 and Decade Module Assy A11 thru A16 - Schematic . . . . .	5-21/5-22
3-2. Operating Instructions . . . . .	3-3	5-15. Modulator Assy A3 - Component Location . . . . .	5-23/5-24
4-1. Circuit Details . . . . .	4-2	5-16. Modulator Assy A3 - Schematic . . . . .	5-23/5-24
4-2. Block Diagram . . . . .	4-5	5-17. DC Amplifier Assy A6 and A7 - Component Location . . . . .	5-25
5-1. Frequency Dial Calibration . . . . .	5-2	5-18. Low Pass Filter Assy A4, DC Ampl Assy A6 and Square Wave Gen Assy A8 - Schematic . . . . .	5-25
5-2. Frequency Response . . . . .	5-2	5-19a. Low Pass Filter Assy A4 and A5 - Component Location . . . . .	5-26
5-3. Sine Wave Check . . . . .	5-4	5-19b. Square Wave Gen Assy A8 and A9 - Component Location . . . . .	5-27/5-28
5-4. Square Wave Check . . . . .	5-4	5-20. Low Pass Filter Assy A5, DC Ampl Assy A7, and Square Wave Gen Assy - Schematic . . . . .	5-27/5-28
5-5. Phase Lag Check . . . . .	5-5	5-21. Power Supply Assy A22-Component Location . . . . .	5-29
5-6. Phase Lag Dial Adjustment . . . . .	5-10	5-22. Power Supply Assy A22 and Rectifier Assy A21 - Schematic . . . . .	5-29
5-7. Typical Waveforms . . . . .	5-12/5-13/5-14	5-23. Frequency Tuning Assy, Mechanical Parts . . . . .	5-30
5-8. Chassis - Top View . . . . .	5-15/5-16		
5-9. 5 Mc Oscillator and 9:1 Divider Assembly A1-Component Location . . . . .	5-17/5-18		
5-10. 5 Mc Oscillator and 9:1 Divider Assembly A1 - Schematic . . . . .	5-17/5-18		
5-11. RF Amplifier Assembly A2 - Component Location . . . . .	5-19		
5-12. RF Amplifier Assembly A2 and Adjustable Phase Shifter Assembly A25 - Schematic . . . . .	5-19		
5-13a. VFO Assy A10 - Component Location . . . . .	5-20		

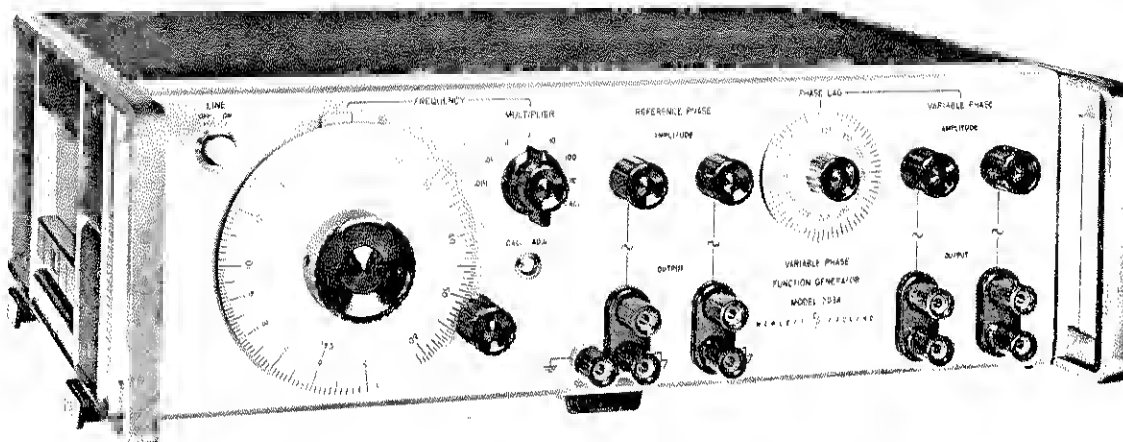

Figure 1-1. Model 203A Variable Phase Function Generator

Table 1-1. Specifications

<p><b>FREQUENCY RANGE</b></p> <p>0.005 Hz to 60 kHz in seven decade ranges. *</p> <p><b>DIAL ACCURACY</b></p> <p>±1% of reading.</p> <p><b>FREQUENCY STABILITY</b></p> <p>Within ±1% including warmup drift and line voltage variations of ±10%.</p> <p><b>OUTPUT WAVEFORMS</b></p> <p>Sine and square waves are available simultaneously. All outputs have common chassis terminal.</p> <p><b>MAXIMUM OUTPUT VOLTAGE</b></p> <p>30 volts peak-to-peak open circuit for sinusoidal and square waveforms.</p> <p><b>OUTPUT POWER</b></p> <p>5 volts into 600 ohms (40 mw); at least 40 db continuously adjustable attenuation on all outputs.</p> <p>*Two lower ranges of 0.0005 Hz (option: 01) and 0.00005 Hz (option: 02) are available on special order.</p>	<p><b>OUTPUT IMPEDANCE</b></p> <p>600 ohms</p> <p><b>OUTPUT SYSTEM</b></p> <p>Direct coupled output is isolated from ground and may be operated floating up to 500 VDC.</p> <p><b>DISTORTION</b></p> <p>Total harmonic distortion hum and noise &gt; 64 db below fundamental (&lt; .06%) at maximum output.</p> <p><b>FREQUENCY RESPONSE</b></p> <p>±1% referenced to 1 kHz.</p> <p><b>SQUARE WAVE RESPONSE</b></p> <p>Rise and Fall Time: &lt; 200 nsec. Overshoot: &lt; 5%, at full output.</p> <p><b>PHASE RANGE</b></p> <p>0 to 360 degrees. Accuracy: ±5° sine wave. ±10° square wave.</p> <p><b>POWER</b></p> <p>115 or 230 v ±10%, 50 to 400 Hz.</p> <p><b>DIMENSIONS</b></p> <p>Cabinet mount, 5 1/4" high x 16 3/4" wide and 11 1/2" deep (133 x 425 x 286 mm).</p>
---	--

## SECTION I

### GENERAL INFORMATION

#### 1-1. DESCRIPTION.

1-2. The Hewlett-Packard Model 203A Variable Phase Function Generator is a low frequency function generator which provides two sine wave and two square wave test signals at frequencies from 0.005 cps to 60 kc. (Refer to paragraph 1-5, Options Available.)

1-3. The four test signals are provided at the front panel OUTPUT connectors at an open circuit signal level of 30 volts peak-to-peak. The sine wave and square wave test signals provided at the REFERENCE PHASE OUTPUT connectors are fixed in phase and provide a reference phase for the test signals at the VARIABLE PHASE OUTPUT connectors. The variable phase test signals are continuously variable from 0° to 360° lag with respect to the phase of the reference test signals. The amplitude of the four output signals can be varied with individual continuously variable 40 db attenuators (AMPLITUDE controls.)

1-4. The output terminals are floating with respect to ground and can be used to supply an output voltage with the common terminal grounded or can be floated up to 500 volts dc above chassis ground. The output impedance for all four test signal outputs is 600 ohms.

#### 1-5. OPTIONS AVAILABLE.

1-6. Options 01 and 02 are available to provide two additional frequency ranges to the Model 203A. Option 01 includes one additional Decade Module Board Assembly which extends the lower limit of the frequency range from 0.005 cps to 0.0005 cps. Option 02 includes two additional Decade Module Board Assemblies which extend the lower limit of the frequency range from 0.005 cps to 0.00005 cps. These two

options can also be installed as a field modification (see Section VI for stock number of Decade Module Board Assemblies).

#### 1-7. APPLICATIONS.

1-8. The Model 203A can be used for phase shift measurements, vibration studies, servo applications, medical research, distortion measurements, geophysical problems, subsonic and audio testing.

#### 1-9. INSTRUMENT IDENTIFICATION.

1-10. Hewlett-Packard uses a two-section nine character (0000A00000) or eight character (000-00000 or 000A00000) serial number. The first three or four digits (serial prefix) identify a series of instrument; the last five digits identify a particular instrument in that series. A letter placed between the two sections identifies the country where the instrument was manufactured. The serial number appears on a plate located on the rear panel. All correspondence with Hewlett-Packard Sales/Service Offices with regard to an instrument should refer to the complete serial number.

1-11. If the serial prefix does not agree with the serial prefix on the title page of this manual, a "Manual Changes" sheet supplied will describe changes which will adapt this manual to an instrument with a different serial prefix. Technical corrections (if any) to this manual, due to known errors in print, are called Errata and are shown on the change sheet. For information on manual coverage of any hp instrument, contact the nearest hp Sales/Service Office (addresses are listed at the rear of this manual).

## SECTION II INSTALLATION

### 2-1. INSPECTION.

2-2. This instrument was carefully inspected both mechanically and electrically before shipment. It should be physically free of marks or scratches and in perfect electrical order upon receipt. To confirm this, the instrument should be inspected for physical damage in transit. Also check for supplied accessories, and test the electrical performance of the instrument using Table 2-1 or the procedure outlined in paragraph 5-3. If there is any apparent damage, file a claim with the carrier and refer to the warranty on the inside front cover of this manual.

### 2-3. POWER REQUIREMENTS.

2-4. The Model 203A will operate from either 115 or 230 vac, 50-400 Hz. The instrument can be easily converted from 115 to 230 volt operation by changing the position of the slide switch, located on rear panel, so that the designation appearing on the switch matches the nominal voltage of the power source.

### 2-5. THREE-CONDUCTOR POWER CABLE.

2-6. To protect operating personnel, the National Electrical Manufacturers' Association (NEMA) recommends that the instrument panel and cabinet be grounded. All Hewlett-Packard instruments are equipped with a three-conductor power cable which, when plugged into an appropriate receptacle, grounds the instrument. The offset pin on the power cable three-prong connector is the ground wire.

2-7. To preserve the protection feature when operating the instrument from a two-contact outlet, use a three-prong to two-prong adapter and connect the green pigtail on the adapter to ground.

### 2-8. INSTALLATION.

2-9. The Model 203A is fully transistorized; therefore no special cooling is required. However, the instrument should not be operated where the ambient temperature exceeds 55°C (131°F).

### 2-10. RACK/BENCH INSTALLATION.

2-11. The Model 203A is initially shipped as a bench type instrument (unless ordered specifically as a rack type) with plastic feet and a tilt stand in place. Conversion to a rack-mounted instrument can be accomplished by using the rack mounting kit and instructions furnished with your instrument.

### 2-12. REPACKAGING FOR SHIPMENT.

2-13. The following is a general guide for repackaging an instrument for shipment. If you have any questions, contact your local Sales and Service Office (see lists in Appendix for location).

a. Place instrument in original container if it is available. If original container is not available, one can be purchased from your nearest Sales and Service Office.

#### Note

If instrument is to be shipped to Hewlett-Packard for service or repair, attach to the instrument a tag identifying the owner and indicate the service or repair to be accomplished; include the model number and full serial number of instrument. In any correspondence, identify the instrument by model number and serial number prefix.

If original container is not used,

b. Wrap instrument in heavy paper or plastic before placing in an inner container.

c. Use plenty of packing material around all sides of instrument and protect panel face with cardboard strips.

d. Place instrument and inner container in a heavy carton or wooden box and seal with strong tape or metal bands.

e. Mark shipping container with "Delicate Instrument," "Fragile" etc.



Table 2-1. Checks for Incoming Inspection (Specifications)

Check	Test Equipment	203A Control Settings	Output Connector	Specifications
Maximum Output Voltage	Oscilloscope	Amplitudes fully clockwise FREQUENCY 1 kc	REFERENCE PHASE ~ REFERENCE PHASE ⊥ VARIABLE PHASE ~ VARIABLE PHASE ⊥	Open Circuit: 30 v PTP 600 Ω load: ~ > 5 v RMS ⊥ 15 v PTP
Frequency Range	Oscilloscope DC Coupled	All ranges at low end and high end of dial	Any one output	005 cps to 60 kc (output at all points)
Square Wave Response Rise Time Fall Time Ampl. of Overshoot Rise Time Fall Time Ampl. of Overshoot	Oscilloscope DC Coupled	FREQUENCY 60 kc	REFERENCE PHASE ⊥  VARIABLE PHASE ⊥	< 200 nsec < 200 nsec < .75 volts (5%)  < 200 nsec < 200 nsec < .75 volts (5%)
Dial Accuracy	Electronic Counter (Use period for low frequencies)	FREQUENCY-All ranges at least two points on the dial	Any one output	±1% of reading
Frequency Response	Oscilloscope DC Coupled	REFERENCE: 1 kc Check all ranges at least three points on the dial	REFERENCE PHASE ~ VARIABLE PHASE ~	±1% referenced to 1 kc
Distortion	Distortion Analyzer	All ranges at least one point on dial	REFERENCE PHASE ~ VARIABLE PHASE ~ (Rotate phase dial to achieve worst case)	> - 64 db > - 64 db

## SECTION III OPERATION

### 3-1. INTRODUCTION.

3-2. The Model 203A generates two sine wave and two square wave signals which are available simultaneously at the front panel OUTPUT connectors. The output signal frequency is determined by the position of the FREQUENCY dial and FREQUENCY MULTIPLIER switch. By the use of the PHASE LAG control, the phase of the VARIABLE PHASE OUTPUT signals (one sine wave and one square wave) can be continuously adjusted from 0° to 360° with respect to the REFERENCE PHASE OUTPUT signals. The OUTPUT terminals provide an open-circuit signal level of 30 volts peak-to-peak. The individual AMPLITUDE controls provide 40 db of attenuation for each output signal. The CAL ADJ control provides a means of calibrating the FREQUENCY dial with the line frequency.

### 3-3. CONTROLS AND INDICATORS.

3-4. Figure 3-1 describes the function of all front panel controls, connectors, and indicators. The description of each component is keyed to a drawing which is included within the figure.

### 3-5. OPERATING INSTRUCTIONS.

3-6. Figure 3-2 contains operating procedures keyed to a drawing included in the figure. Refer to figure 3-1 for the function of each control and paragraph 2-3 for setting the line voltage switch.

### 3-7. CALIBRATION FOR 60 CYCLE LINE FREQUENCY.

3-8. A quick procedure for checking the calibration of the frequency dial is as follows:

- a. Set the FREQUENCY dial to 6 (CAL).
- b. Set the FREQUENCY MULTIPLIER to CAL. (The pilot light will flicker.)
- c. Adjust the CAL ADJ for minimum rate of flicker.

#### Note

If the flicker rate is not close to minimum, use the Frequency Calibration check paragraph 5-5.

When the FREQUENCY MULTIPLIER switch is in the CAL position, there is no output at the REFERENCE PHASE OUTPUT connector.

### 3-9. CALIBRATION FOR LINE FREQUENCIES OTHER THAN 60 CYCLES.

3-10. For line frequencies other than 60 cps the FREQUENCY dial is set to 1/10 of the line frequency (40 to 400 cps line frequency). Again the calibration is made with the front panel CAL ADJ control, which is adjusted for a minimum flicker rate of the pilot lamp. For line frequencies above 600 cps the FREQUENCY dial is set to 1/30 of the line frequency (33.3 for a 1000 cps line frequency). At the higher line frequencies the flicker intensity decreases and the CAL ADJ control sensitivity increases.

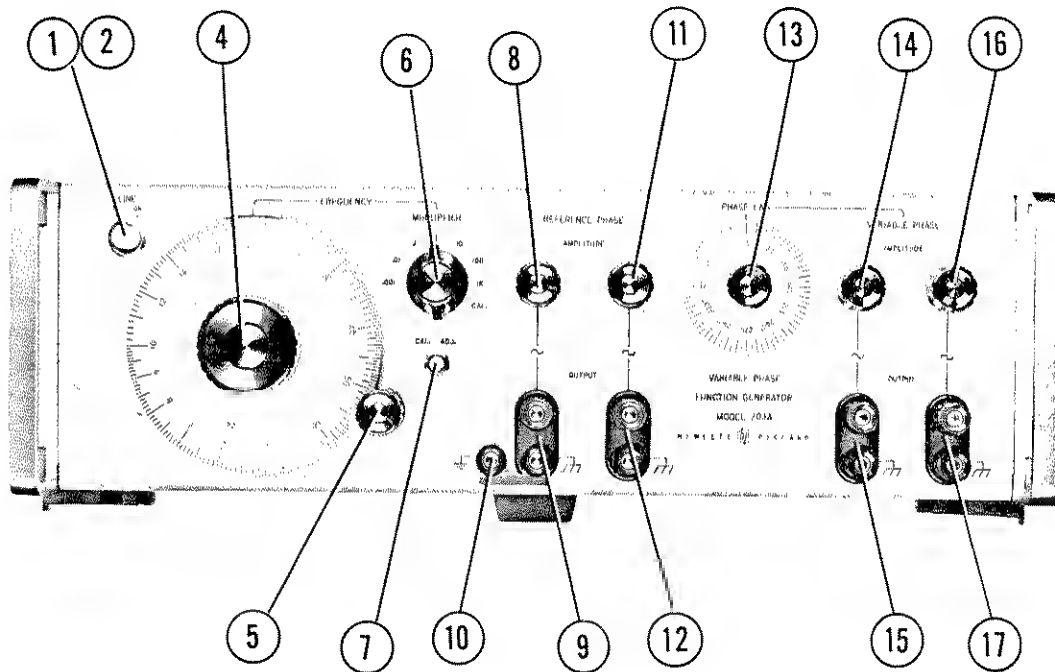

- |  |   |
|--|---|
| <p>1. Push ON/OFF power switch.</p> <p>2. Pilot light and calibration indicator.</p> <p>3. Not Assigned.</p> <p>4. FREQUENCY selector dial, indicates cps times the FREQUENCY MULTIPLIER switch setting.</p> <p>5. Vernier, provides fine frequency adjustment.</p> <p>6. FREQUENCY MULTIPLIER, selects frequency range and in the CAL position sets up the 203A for frequency dial calibration (see paragraph 3-7).</p> <p>7. CAL ADJ, adjust frequency dial calibration (see paragraph 3-7).</p> <p>8. REFERENCE PHASE channel sine wave AMPLITUDE control, provides continuous adjustable attenuation of up to 40 db.</p> <p>9. REFERENCE PHASE channel sine wave output terminals, provide a nominal 30 volts peak-to-peak from a 600 ohm source impedance.</p> <p>10. Earth Ground.</p> | <p>11. REFERENCE PHASE channel square wave AMPLITUDE control, provides continuously adjustable attenuation of up to 40 db.</p> <p>12. REFERENCE PHASE channel square wave output terminals, provide a nominal 30 volts peak-to-peak from a 600 ohm source impedance.</p> <p>13. PHASE LAG control, provides continuously adjustable phase lag from <math>0^{\circ}</math> through <math>360^{\circ}</math> of the variable phase channel with respect to the reference phase channel.</p> <p>14. VARIABLE PHASE channel sine wave AMPLITUDE control, provides continuously adjustable attenuation of up to 40 db.</p> <p>15. VARIABLE PHASE channel sine wave output terminals, provide a nominal 30 volts peak-to-peak from a 600 ohm source impedance.</p> <p>16. VARIABLE PHASE channel square wave AMPLITUDE control, provides continuously adjustable attenuation of up to 40 db.</p> <p>17. VARIABLE PHASE channel square wave output terminals, provide a nominal 30 volts peak-to-peak from a 600 ohm source impedance.</p> |
|--|---|

Figure 3-1. Front Panel Description

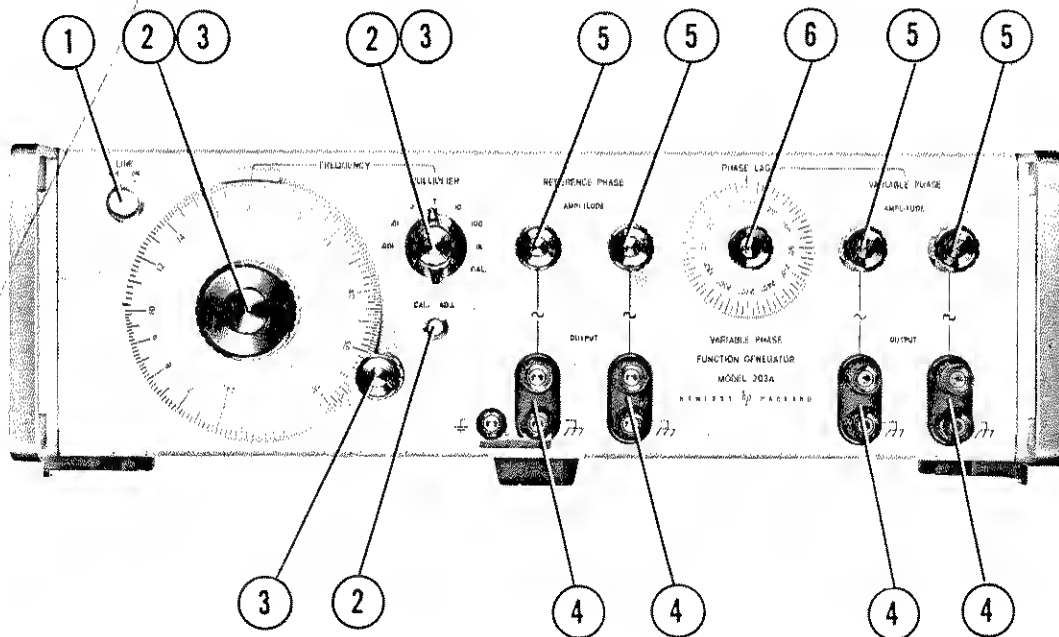

1. Push LINE switch ON, pilot lamp glows.

2. The Frequency Calibration may be compared to line frequency as described in paragraph 3-7.

3. Set FREQUENCY dial and MULTIPLIER switch to desired output frequency. Use vernier control on FREQUENCY dial for fine-frequency adjustments.

4. Select the desired test signal(s) and connect load to OUTPUT connector(s).

5. Set AMPLITUDE control(s) for desired signal level.

6. Set PHASE LAG control for desired degree of phase lag of the VARIABLE PHASE test signal(s) with respect to the REFERENCE PHASE test signal(s).

Figure 3-2. Operating Instructions

## SECTION IV

### PRINCIPLES OF OPERATION

#### 4-1. OVERALL DESCRIPTION.

4-2. This section describes how the Model 203A Variable Phase Function Generator operates. The block diagram, figure 4-2, shows the main sections and the signal flow within the Model 203A.

4-3. The Model 203A is a beat-frequency oscillator which, by mixing two high-frequency signals, generates signals in the frequency range of 0.005 cps to 60 kc (refer to paragraph 1-5 for options). One of the high-frequency signals is a fixed frequency; the other is variable. The Model 203A has two signal channels, REFERENCE PHASE and VARIABLE PHASE, each of which produces a sine-wave signal and a square-wave signal. The two channels are electrically similar except that the VARIABLE PHASE channel contains a continuously adjustable phase-shifting circuit which changes the phase relationship of the VARIABLE PHASE OUTPUT with respect to the REFERENCE PHASE OUTPUT. The four signals (two reference phase and two variable phase) are available simultaneously at the OUTPUT connectors.

4-4. The fixed frequency signal, which is generated by a crystal oscillator, is applied to both channels and routed to a modulator through an RF Amplifier within each channel. The variable frequency signal is applied directly to the modulator of each channel. The frequency of the variable frequency signal is controlled by the position of the FREQUENCY dial and the setting of the FREQUENCY MULTIPLIER switch. These two signals are mixed in the modulator and the difference in frequency between the two signals is the output frequency of the Model 203A.

#### 4-5. CRYSTAL OSCILLATOR AND DIVIDER ASSEMBLY (A1).

4-6. Assembly A1 consists of a crystal controlled oscillator and a 9:1 frequency divider. Refer to the schematic diagram, figure 5-10, for circuit details.

#### 4-7. CRYSTAL OSCILLATOR.

4-8. The oscillator (A1Y1 and A1Q1) is a crystal controlled grounded base Colpitts oscillator. The 5 Mc output is applied through buffer amplifier A1Q2, for isolation, to the base of the 9:1 frequency divider.

#### 4-9. 9:1 FREQUENCY DIVIDER.

4-10. The 9:1 divider consists of a divider A1Q3 and a tank circuit which consists of A1C8, A1C9, A1C11, and A1L2. The divider is basically a class C grounded base Colpitts oscillator.

4-11. Two things occur during each cycle of the divider operation. One is amplitude modulation of the signal applied to the base of A1Q3, and the second is a mixing action within A1Q3. Each function occurs at

a different time during each cycle of oscillation and together tend to synchronize A1Q3 with a sub-multiple frequency of the frequency applied to the base of the divider.

4-12. Divider A1Q3 operates in the region of voltage saturation for a portion of each cycle. During the saturation period, the impedance between the base and collector of A1Q3 becomes very low; for the rest of cycle the impedance between the base and collector is relatively high. The variation in impedance between base and collector of A1Q3 results in amplitude modulation (about 10%) of the signal on the base of the divider. This amplitude modulation creates sidebands at the 8th and 10th harmonic of the divider oscillating frequency.

4-13. The signal applied to the base of A1Q3 is about 4.995 Mc which is generated by the crystal oscillator circuit. The tank circuit of the 9:1 divider is tuned so that A1Q3 is oscillating at the 9th sub-multiple frequency of 4.995 Mc (555 kc).

4-14. The mixing process within A1Q3 occurs at the time during each cycle when the divider just starts to conduct. During this short time, the 8th and 10th harmonic of the 555 kc signal are mixed with the 9th harmonic resulting in a frequency component at 555 kc which influences the oscillations of A1Q3. The result is that A1Q3 stays synchronized to the 9th sub-harmonic of 4.995 Mc.

4-15. The pi type tank circuit filters out harmonic frequencies which may be present at the collector of A1Q3. A buffer amplifier A1Q4 provides further filtering, isolation, and power gain. The output of the 9:1 divider is a 555 kc signal and is coupled by A1T2 to A2Q1 and A2Q2 (see figures 5-10 and 5-12).

#### 4-16. VARIABLE PHASE SHIFTER ASSEMBLY.

4-17. The variable phase shifter assembly A25 (figure 5-12) is a goniometer consisting of two stator windings, a rotor winding, and associated circuits. The goniometer requires two 555 kc input signals; one from A2Q2 to one of the stator windings, and the other from A2Q1 and the 90° phase shift network to the other stator winding. The output phase corresponds to the angle of the rotor winding (PHASE LAG control). The phase can be continuously adjusted from 0° through 360° with respect to the reference signal while maintaining a constant amplitude. The adjustable phase shifter output is applied to the RF amplifier assembly A2 (figure 5-12).

#### 4-18. RF AMPLIFIERS (A2).

4-19. The RF amplifier assembly A2 consists of two RF amplifiers; A2Q3, A2Q4, and A2Q5 for the reference phase channel and A2Q6 through A2Q9 for

the variable phase channel. Refer to the schematic diagram (figure 5-12) for circuit details.

4-20. VARIABLE PHASE CHANNEL RF AMPLIFIER.

4-21. The signal from the variable phase shifter is amplified by A2Q6, then applied to the base of A2Q7. A2Q7 and A2Q8 act as an over-driven amplifier which amplifies and clips the signal applied to the base of A2Q7; this operation produces a square wave of current at the collector of A2Q8. The zero crossing of the square wave of current coincides with the zero crossing of the sine wave signal applied to the base of A2Q7 so that the phase of the applied signal is preserved. A tuned network, formed by A2C24, A2C25, A2C29, A2C30, A2L7, and A2T2 filters the 555 kc square-current waveform to a nearly pure sine wave.

4-22. The output of the RF amplifier circuit, which is taken across A2C30, is maintained at a constant amplitude by the level controlling circuit. If the output should increase, the voltage at A2C27 increases, resulting in a voltage increase at the base of A2Q9. This increase is applied to the bases of A2Q7 and A2Q8 which then conduct less average current. When A2Q8 conducts less, the signal at its collector decreases and the output voltage decreases, opposing the original change. The result is that the amplitude of the output remains nearly constant despite variations in the amplitude of the input signal. The output signal is then applied to A3T4 in the modulator assembly A3 (figure 5-16).

4-23. REFERENCE PHASE CHANNEL RF AMPLIFIER.

4-24. The signal present at the emitter of A2Q2 is applied to the reference phase channel RF amplifier section, A2Q3 through A2Q5. This stage operates

the same as the variable phase channel RF amplifier described in paragraph 4-20. The output signal is then applied to A3T3 in the modulator assembly A3 (figure 5-16).

4-25. VARIABLE FREQUENCY OSCILLATOR (A10).

4-26. The variable frequency oscillator assembly A10 generates a signal that is variable from 495 kc to 550 kc by rotation of the front panel FREQUENCY dial. The FREQUENCY dial is calibrated so that with the dial set at 5 the VFO is oscillating at 550 kc and with the dial set at 60 the VFO is oscillating at 495 kc. The output signal from the variable frequency oscillator is applied to the 1 K position of the MULTIPLIER (frequency range) switch and also to the 1st decade module. Refer to the schematic diagram, figure 5-14, for circuit details.

4-27. DECADE MODULES (A11-A16).

4-28. The six decade module assemblies A11 thru A16 each consist of a mixer, a bandpass filter, and a 10:1 divider. These decades produce a band of high frequency signals that are mixed in the modulators (A3) with the 555 kc fixed frequency signal from the RF amplifiers to produce a signal in the 0.005 cps to 60 kc range (refer to paragraph 1-5 for options). Refer to the schematic diagram, figure 5-14 and figure 4-1 for circuit details.

4-29. DECADE MODULE (A11).

4-30. The 4.995 Mc signal from the crystal oscillator is applied to the emitter of A11Q1 isolation stage, and subsequently appears across the primary of A11T1. The signal from A11T1 is applied to a suppressed carrier, balanced modulator. The 495 kc VFO signal (assume

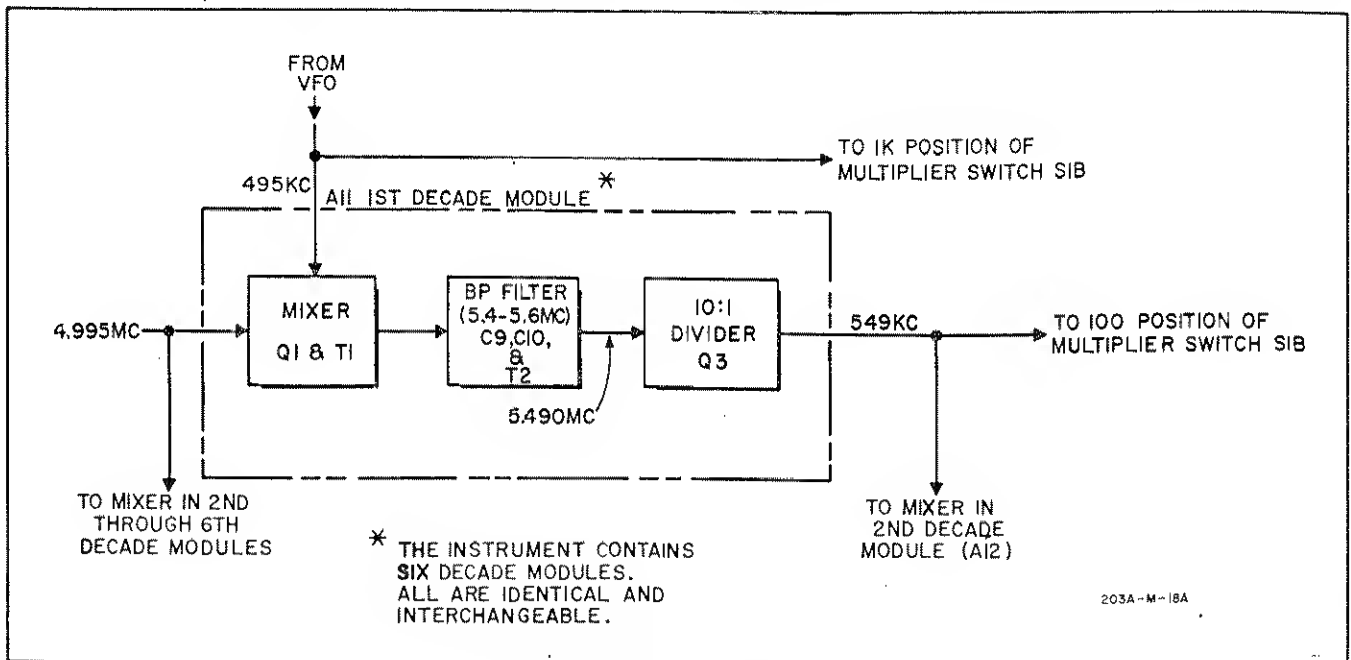

Figure 4-1. Circuit Details

that the FREQUENCY dial is at 60 and the VFO signal is 495 kc) is applied to the other input of the balanced modulator. Both signals are mixed, and the sum and difference of these two frequencies will appear at the output. The signal from the balanced modulator is passed through an LC filter network which is tuned for a band-pass of from 5.4 Mc to 5.6 Mc, which only allows the sum frequency to pass on to the 10:1 divider A11Q3. The 10:1 divider is similar to the 9:1 divider described in paragraph 4-9; the main difference being that the tuned tank circuit in the 10:1 divider is adjusted so that the stage provides an exact 10:1 division of the input frequency. The resultant frequency is fed to the 100 position of the FREQUENCY MULTIPLIER switch and to the mixer in the second decade module A12.

#### 4-31. DECADE MODULES, A12 THROUGH A16.

4-32. The action within the succeeding decade module is the same as that described for the first decade module A11. The output of each module is applied to a position of the FREQUENCY MULTIPLIER switch and to the mixer in the following decade module. Thus a set of variable frequency signals are produced and when mixed with the constant high-frequency signal in the modulator (A3) a beat frequency is produced. The beat frequency is decreased by a factor of 10 for each lower range of the FREQUENCY MULTIPLIER switch.

#### 4-33. MODULATOR ASSEMBLY, A3.

4-34. The Modulator assembly A3 consists of a modulator drive amplifier and two balanced switching type modulators; one for the REFERENCE PHASE channel, and the other for the VARIABLE PHASE channel. Refer to the schematic diagram, figure 5-16, for details.

#### 4-35. MODULATOR DRIVER AMPLIFIER.

4-36. The frequency selected by the FREQUENCY dial and the FREQUENCY MULTIPLIER is applied to the input of the modulator driver amplifier A3Q1 where it is amplified and applied to A3Q2 and A3Q3. A3Q2 and A3Q3 act as an over driven amplifier which amplifies and clips the signal applied to the base of A3Q2. This operation produces a square wave output at the collector of A3Q3 which is applied to the modulator section as a switching signal.

#### 4-37. REFERENCE PHASE CHANNEL MODULATOR.

4-38. The modulator driving signal (VFO and decade output) is applied to the bases of the switching transistors (A3Q5 thru A3Q8). The fixed frequency, a 555 kc sine wave, is applied through series resistors to the emitters of the switching transistors. The output at the collectors is sine wave of the sum and difference frequencies. This signal is applied to the low pass filter assembly A4 (figure 5-18). The filter passes only the difference frequency, the output is a sine wave having a frequency that is between 0.005 cps and 60 kc depending on the position of the FREQUENCY MULTIPLIER switch and the FREQUENCY dial setting

(refer to paragraph 1-5 for Options). The output signal is applied to the dc amplifier A6.

4-39. A dc reference voltage is derived by summing the signals at the collectors of A3Q5 and A3Q6. This dc reference voltage is used as a reference voltage for the differential amplifier in the dc amplifier assembly A6.

#### 4-40. VARIABLE PHASE CHANNEL MODULATOR.

4-41. The variable phase channel modulator operates the same as the reference phase channel described in paragraph 4-37, except that the output is applied to the Low Pass Filter A5 and then to the dc amplifier A7.

#### 4-42. DC AMPLIFIER ASSEMBLIES A6 AND A7.

4-43. After passing through the low pass filter the signal is fed to the direct coupled amplifiers; A6 for the reference phase channel, and A7 for the variable phase channel. Refer to the schematic diagrams figures 5-18 and 5-20 for circuit details.

#### 4-44. REFERENCE PHASE CHANNEL DC AMPLIFIER ASSEMBLY.

4-45. The dc amplifier uses a differential amplifier for the input stage. The dc reference voltage from the modulator section is used as the reference input for the differential amplifier. This configuration minimizes any tendency of dc drift due to power supply temperature variations. The dc amplifier circuit uses negative feedback to provide for low distortion amplification. The output is applied to a bridged-T type attenuator and the square wave generator A8.

#### 4-46. VARIABLE PHASE CHANNEL DC AMPLIFIER ASSEMBLY.

4-47. The variable phase channel dc amplifier operates the same as the reference phase channel described in paragraph 4-44, except that the output is applied to bridged-T type attenuator and the square wave generator, A9.

#### 4-48. SQUARE WAVE AMPLIFIER ASSEMBLIES A8 AND A9.

4-49. The output sine wave from the dc amplifier is applied to a square wave generator section, A8, for the REFERENCE PHASE channel, and A9 for the VARIABLE PHASE channel. Refer to the schematic diagrams, figures 5-18 and 5-20, for circuit details.

#### 4-50. REFERENCE PHASE CHANNEL SQUARE WAVE GENERATOR.

4-51. The sine wave from the dc amplifier is amplified by A8Q1 then applied to the base of A8Q2. A8Q2 and A8Q3 act as an over driven amplifier which ampli-

fies and clips the signal applied to the base of A8Q2, and produces a square wave at the collector of A8Q3. This square wave is applied to A8Q4 and A8Q5 which form a Schmitt trigger circuit. The Schmitt trigger is a regenerative circuit which changes states abruptly when the input signal crosses a specific dc triggering level. The output from this stage is a square wave having a rise time of less than 0.2 microsecond with the same frequency and phase as the sine wave signal applied to the circuit. The output is applied to a bridged-T attenuator.

**4-52. VARIABLE PHASE CHANNEL SQUARE WAVE GENERATOR.**

4-53. The variable phase channel square wave generator operates the same as the reference phase channel described in paragraph 4-50.

**4-54. DC POWER SUPPLY A21, A22.**

4-55. The dc power supply provides regulated -15, -15, and -24.5 volts and unregulated +35 volts.

**4-56. CALIBRATION FEATURE.**

4-57. A quick check for calibration of the frequency dial is a comparison between instrument and line frequency. The FREQUENCY dial is set to 6 (CAL) and the FREQUENCY MULTIPLIER is set to the CAL position. Through S1BR a 60 cycle output from A11 is applied to the pilot light which will mix with the 60 cycle line frequency. The pilot light will flicker at the difference or beat rate. This rate may be adjusted to minimum by the CAL ADJ control which slightly affects the VFO frequency. At a minimum rate of flicker the instrument's 60 cycle frequency will be most nearly like the 60 cycle line frequency. For checking the exact frequencies throughout the ranges see paragraph 5-5 Frequency Dial Calibration.



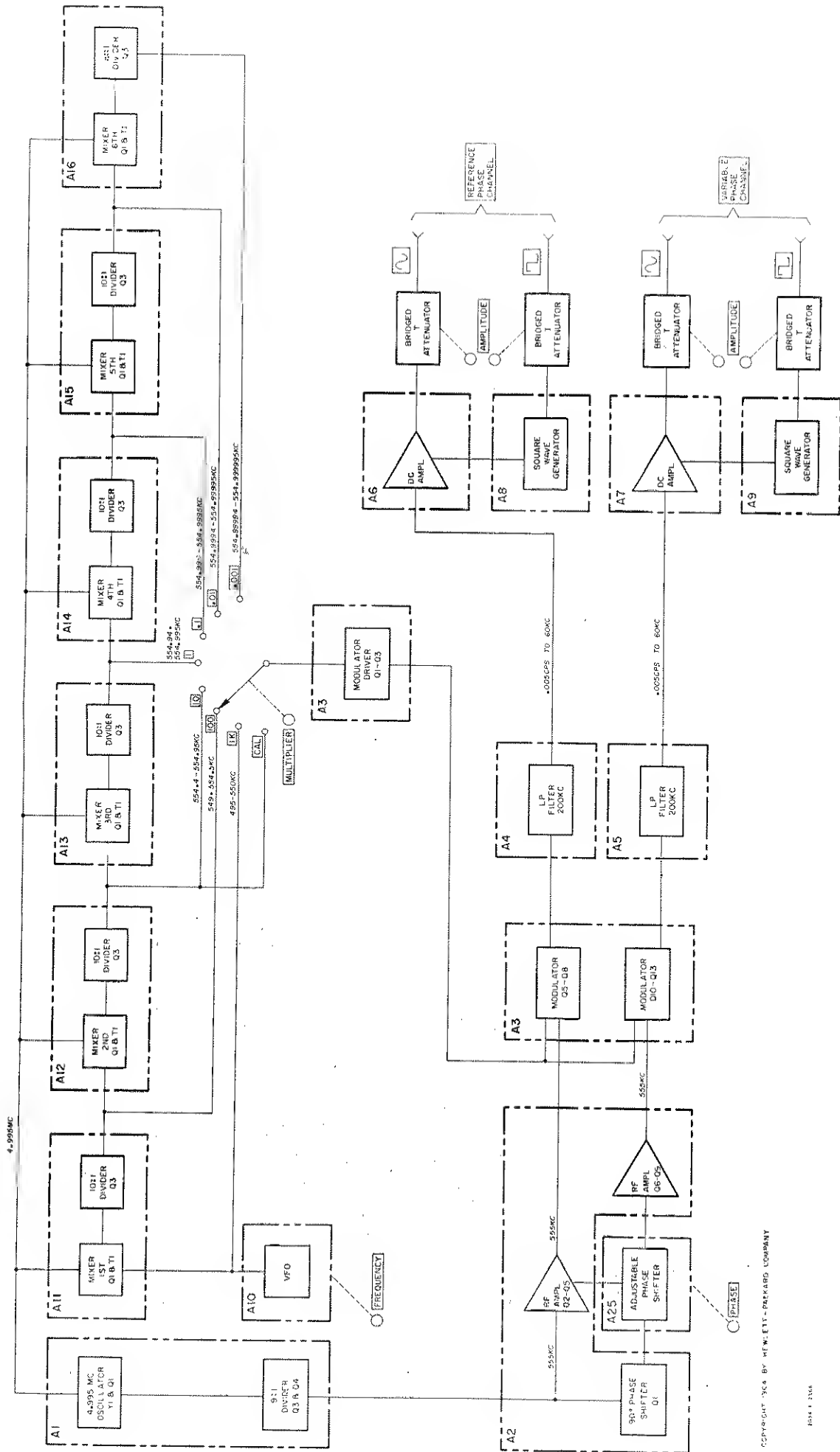

COPYRIGHT 1964 BY HEWLETT-PACKARD COMPANY

1044 • 2156

## SECTION V MAINTENANCE

### 5-1. REQUIRED TEST EQUIPMENT.

5-2. Recommended test equipment for troubleshooting and performance checking is listed in table 5-1. Test instruments other than those listed may be used if their specifications equal or exceed the required characteristics.

### 5-3. PERFORMANCE CHECKS.

5-4. Use the following front panel procedures to verify proper operation of the Model 203A. The Model 203A and test equipment should be operated at 115/230 vac unless otherwise specified. If the Model 203A is not within specifications at any point in this procedure, refer to paragraph 5-12, ADJUSTMENTS.

### 5-5. FREQUENCY DIAL CALIBRATION.

a. Push Model 203A LINE switch ON. Pilot light should glow.

b. Set FREQUENCY dial to 6 (CAL); MULTIPLIER switch to CAL.

c. Adjust front panel CAL ADJ until visual zero beat is obtained on front panel pilot light. This occurs when flashing rate of the pilot light approaches zero.

d. Connect Model 203A as shown in figure 5-1.

e. Rotate FREQUENCY dial and observe Electronic Counter readings at points shown in table 5-2; counter readings should be within limits shown. At frequencies below 100 cps use period measurements.

Table 5-1. Required Test Equipment

Instrument Type	Required Characteristics	Use	Recommended Model
DC Voltmeter	Voltage Range: 0 - 50 volts Input Impedance > 10 M ohms Accuracy: $\pm 1\%$	Performance Checks	Model 412A
AC Voltmeter	Voltage Range: 1 mv - 100 v Freq. Response: to 600 kc Accuracy: $\pm 2\%$	Performance Checks	Model 403B or Model 400D/H/L
Oscilloscope	Bandwidth: DC - 5 mc	Waveform Checking	Model 175A with Model 1780A Horizontal Plug-In Model 1750A Vertical Plug-In Model 10003A 10:1 Probe
Frequency Counter	Range: 0.005 cps - 60 kc	Performance Checks	Model 523C
Distortion Analyzer	Range: 5 cps to 60 kc	Performance Checks	Model 331A
Variable Transformer	Output Voltage: 103 - 127 vac	Performance Checks	Powerstat
6 pin printed board extender		Troubleshooting Adjustment	#5060-0651
15 pin printed board extender		Troubleshooting Adjustment	#5060-0047
Thermal 50 $\Omega$ Converter	.45 VAC input, 7.0 mv DC output $\pm 0.2\%$ 5 cps - 60 kc	Frequency Response	Model 11051A
Nylon Tuning Wand		Adjustment	#8730-0016
Soldering Iron and Tips	50 watts Tip Temperature: 800 $^{\circ}$ F Tip Size: 1/16" - 3/32" Round Tip Dia: 3/4"	Troubleshooting Repair	Ungar No. 776 handle with Ungar No. PL333 triplet and Ungar No. 885 3/4" cups tip

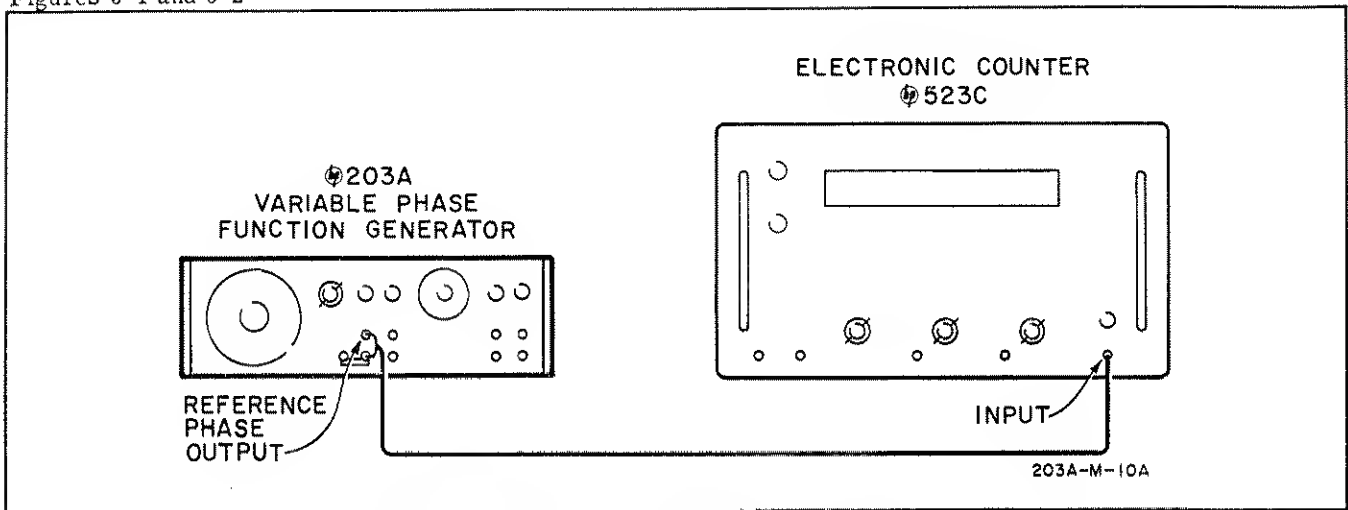

Figure 5-1. Frequency Dial Calibration

This table can be used at all MULTIPLIER switch settings by changing the decimal point of the given counter reading.

**CAUTION**

INSURE THAT ALL FOUR AMPLITUDE CONTROLS ARE FULLY COUNTERCLOCKWISE TO AVOID DAMAGE TO THE THERMAL CONVERTER.

5-6. FREQUENCY RESPONSE.

a. Set Model 203A controls as follows:

FREQUENCY . . . . .	10
MULTIPLIER . . . . .	100

b. Connect Model 203A as shown in figure 5-2, using very short leads between the Model 203A and Thermal Converter.

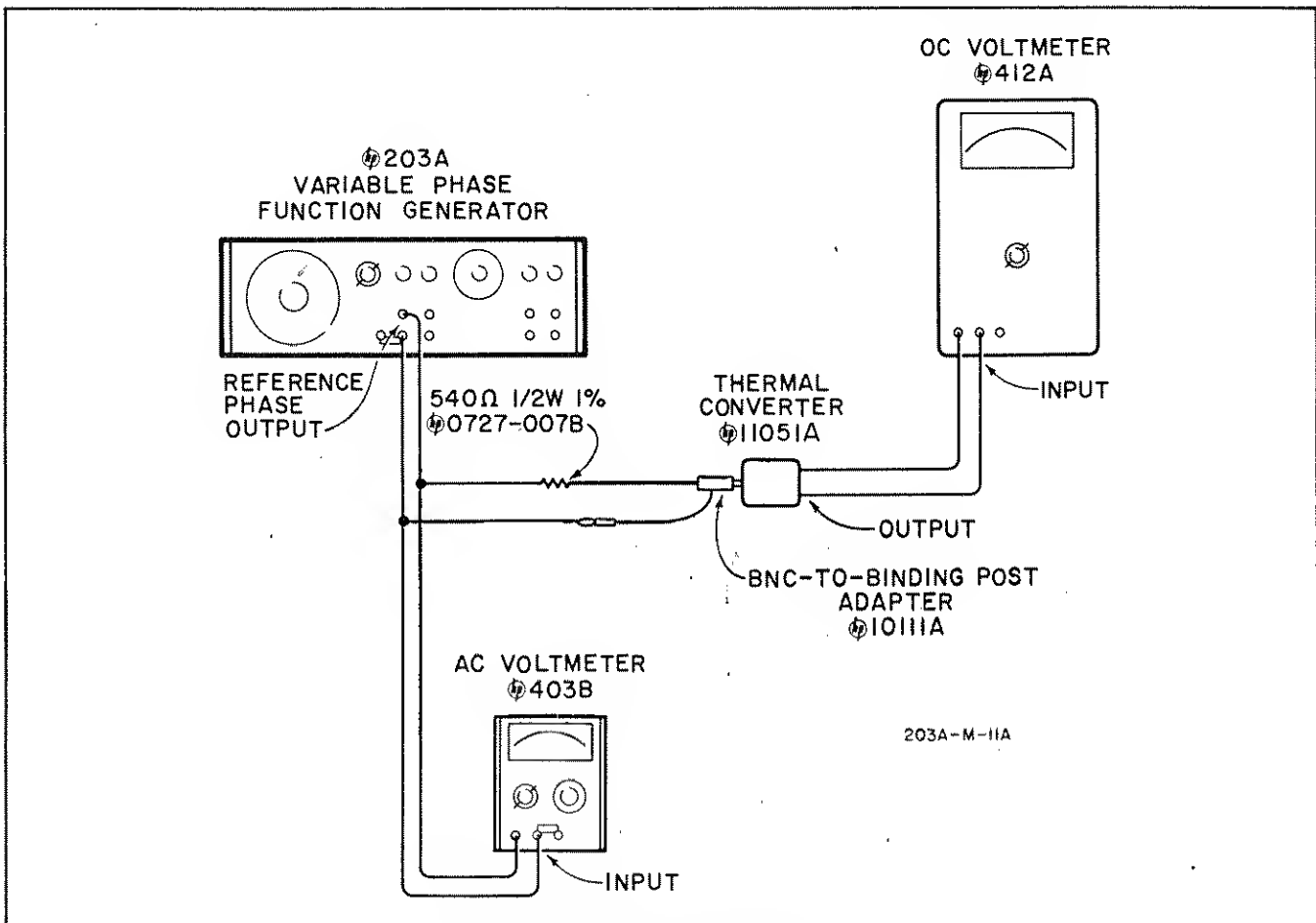

Figure 5-2. Frequency Response

Table 5-2. Frequency Dial Calibration

FREQUENCY Dial	Counter Period Measurement (below 100 cps)		Counter Frequency Measurement (above 100 cps)	
	Minimum	Maximum	Minimum	Maximum
5	1980	2020	495	505
6	1650	1684	594	606
7	1415	1443	693	707
8	1238	1263	793	808
9	1100	1122	891	909
10	990	1010	990	1010
12	825	841	1188	1212
14	707	721	1386	1414
17	582	594	1683	1717
20	495	505	1980	2020
25	396	404	2475	2525
30	330	336	2970	3030
40	247	253	3960	4040
50	198	202	4950	5050
60	165	169	5940	6060

**CAUTION**

DO NOT EXCEED 7.5 MILLIVOLT OUTPUT AS THE THERMAL CONVERTER IS VERY EASILY DAMAGED BY EXCESSIVE INPUT VOLTAGE.

- c. Set REFERENCE PHASE ~ OUTPUT for a reading of 4.9 vac on the ac voltmeter.
- d. Disconnect AC Voltmeter.
- e. Slowly adjust REFERENCE PHASE ~ OUTPUT for dc voltmeter reading of 7.0 millivolts.

f. Vary Model 203A FREQUENCY from 5 cps to 60 kc.

g. DC voltmeter reading should stay between 6.86 and 7.14 millivolts.

h. Repeat steps b thru g for VARIABLE PHASE OUTPUT.

j. Disconnect resistor, thermal converter and dc voltmeter.

5-7. SINE WAVE CHECK.

- a. Connect Model 203A as shown in figure 5-3.

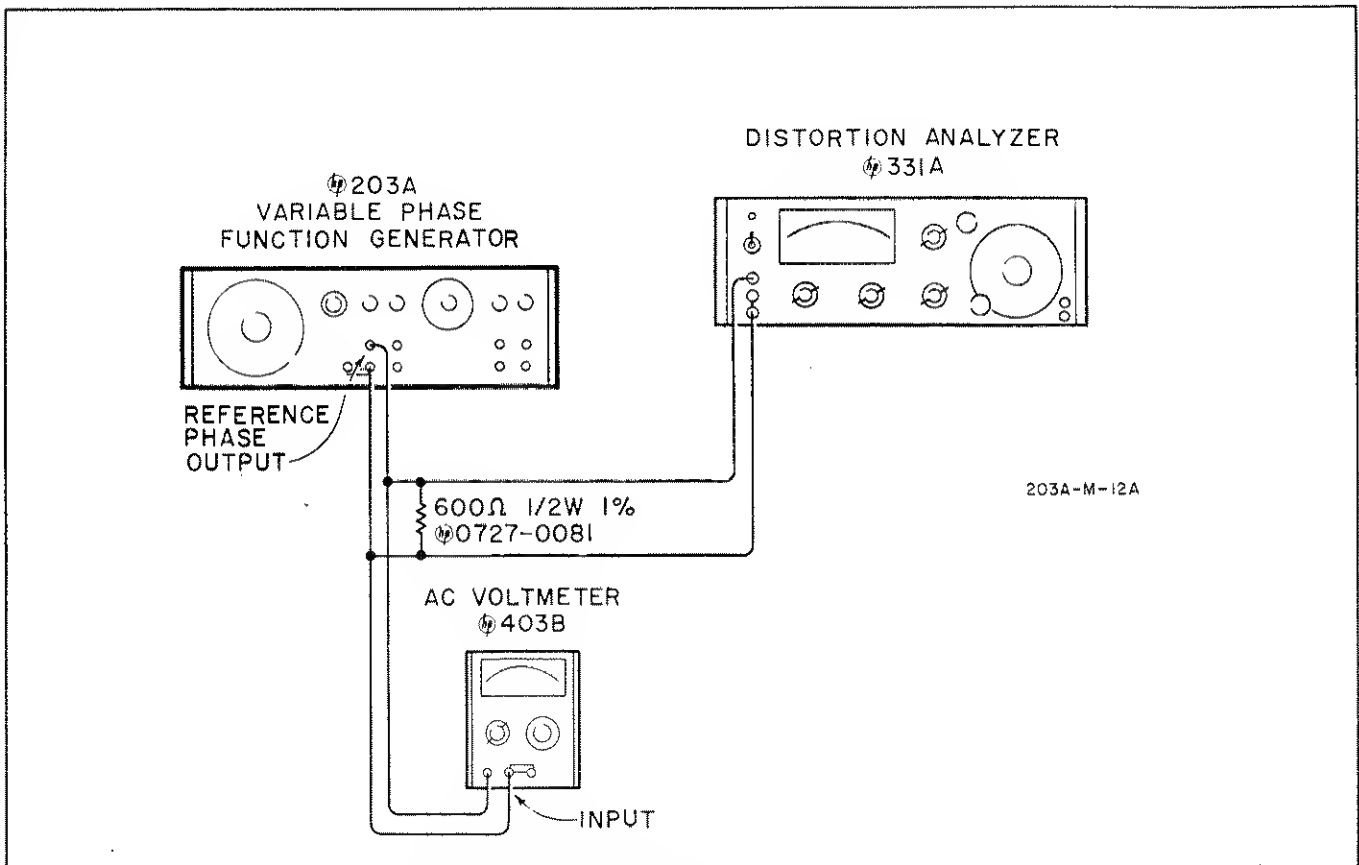

Figure 5-3. Sine Wave Check

b. Set Model 203A controls as follows:

- FREQUENCY . . . . . 10
- MULTIPLIER . . . . . 100
- ~ AMPLITUDE (2) . . . . . both CW

c. AC Voltmeter should read at least 5.3 volts rms.

d. Using Distortion Analyzer, check total harmonic distortion present on signal. Distortion level should be more than 64 db (0.06%) below fundamental frequency reference level.

e. Repeat step d at a number of frequencies between 5 cps and 60 kc.

f. Repeat steps a through e for VARIABLE PHASE ~ OUTPUT.

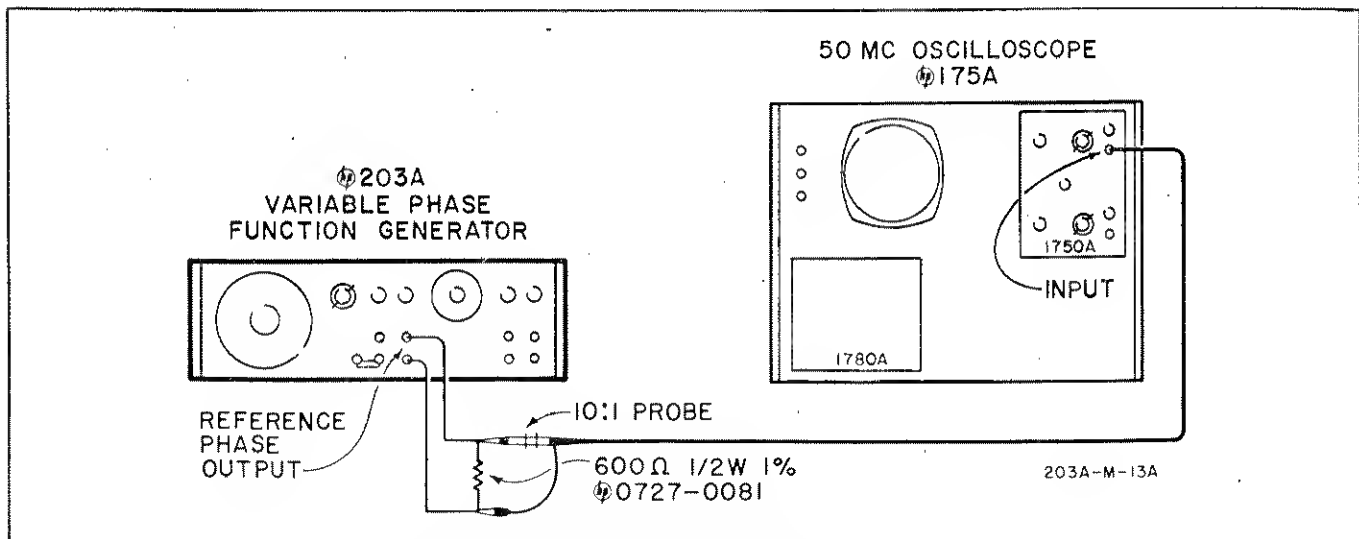

Figure 5-4. Square Wave Check

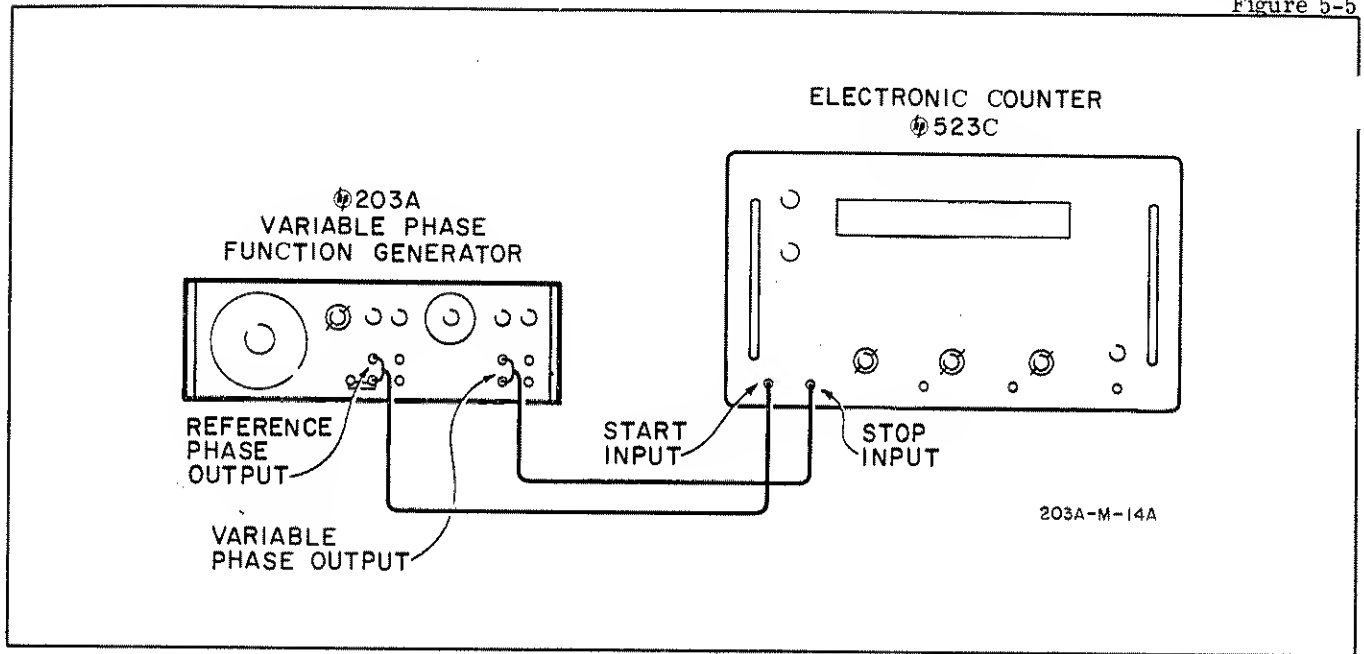

Figure 5-5. Phase Lag Check

5-8. SQUARE WAVE CHECK.

- a. Connect Model 203A as shown in figure 5-4 .
- b. Set instrument controls as follows:

Model 203A

FREQUENCY . . . . . 10  
 MULTIPLIER . . . . . 100  
 AMPLITUDE (2). . . . . both CW

Oscilloscope

INPUT . . . . . DC  
 SENSITIVITY . . . . . .5 V/CM  
 SWEEP TIME . . . . . .1 MSEC/CM  
 TRIGGER SOURCE . . . . . INT  
 TRIGGER SLOPE . . . . . (+)

c. Adjust Model 203A FREQUENCY dial so that one cycle of square wave fills exactly 10 cm of horizontal deflection.

d. Zero crossing of square wave should occur between 4.8 and 5.2 cm from start of sweep. Peak-to-peak voltage should be at least 15 volts.

e. Set Oscilloscope SENSITIVITY to .5 v/cm. Adjust VERTICAL POSITION to bring first, the top of the square wave into view, then the bottom of the square wave.

f. Overshoot should not be more than 5% of the amplitude (1.5 cm).

g. Set Oscilloscope SWEEP TIME to .1 μSEC/CM; SENSITIVITY to .5 V/CM.

h. Square wave rise time should be less than 0.2 μsec from 10% to 90% points.

j. Set Oscilloscope TRIGGER SLOPE to (-).

k. Square wave fall time should be less than 0.2 μsec from 10% to 90% points.

m. Repeat steps b thru k at various frequencies on all ranges.

n. Repeat steps a thru m for VARIABLE PHASE  OUTPUT.

5-9. PHASE LAG CHECK.

- a. Connect Model 203A as shown in figure 5-1.
- b. Set instrument controls as follows:

Model 203A

MULTIPLIER . . . . . 10  
 FREQUENCY . . . . . approximately 27  
 ~ AMPLITUDE . . . . . both CW

Electronic Counter

FUNCTION SELECTOR . . . . . PERIOD  
 STD. FREQ. COUNTED . . . . . 1 MC

c. Adjust Model 203A FREQUENCY dial for Electronic Counter reading of 3600.

d. Connect Model 203A as shown in figure 5-5.

e. Set Electronic Counter controls as follows:

FUNCTION . . . . . TIME INTERVAL  
 TRIGGER INPUT . . . . . SEP  
 TRIGGER SLOPE . . . . . both (+)

- f. Set Model 203A PHASE LAG dial to 180°
- g. Adjust Electronic Counter TRIGGER LEVEL controls for stable reading near 1800.
- h. Check Electronic Counter readings at 30° increments on PHASE LAG dial. Readings should be within the values shown in table 5-3.

Table 5-3. Phase Lag Check

PHASE LAG	ELECTRONIC COUNTER	
	Minimum	Maximum
0	3550	50
30	250	350
60	550	650
90	850	950
120	1150	1250
150	1450	1550
180	1750	1850
210	2050	2150
240	2350	2350
270	2650	2750
300	2950	3050
330	3250	3350

**5-10. INSTRUMENT COVER REMOVAL.**

5-11. To remove either the top or bottom covers, unscrew and remove the two counter-sunk Phillips-head screws which secure the cover to the instrument. Then slide the cover toward the rear of the instrument. To replace the cover, reverse the procedure.

**5-12. ADJUSTMENTS.**

5-13. The following test and adjustment procedures should be performed only if it has been definitely determined by the Performance Checks given in paragraphs 5-5 thru 5-9 that the Model 203A is out of adjustment.

**5-14. POWER SUPPLY A22 ADJUSTMENTS.**

Note

Make the following adjustments with FREQUENCY MULTIPLIER switch in X100 position.

- a. Supply Model 203A primary power from Variable Transformer.
- b. Set line voltage to nominal value (115 volts).
- c. Connect DC Voltmeter and AC Voltmeter to A22 (5). (See figure 5-21.)
- d. Adjust A22R12 (-15 volt adjust) for DC Voltmeter reading of -15.1 vdc. AC Voltmeter should read less than 1.0 mv ripple.
- e. Vary line voltage from 103 to 127 vac. DC Voltmeter reading should not change more than ±0.2 vdc.
- f. Connect DC Voltmeter and AC Voltmeter to A22 (13).
- g. Adjust A22R20 (+15 volt adjust) for DC Voltmeter reading of +15.1 dc. The AC Voltmeter should read less than 1.0 mv ripple.

- h. Vary line voltage from 103 to 127 vac. DC Voltmeter reading should not change more than ±0.2 vdc.
- j. Connect DC Voltmeter and AC Voltmeter to A22 (2).
- k. AC Voltmeter should read less than 2.0 mv ripple. DC Voltmeter should read -24.5 ±0.5 vdc.

Note

It may be possible to bring the -24.5 volt supply into specifications by a slight adjustment of the -15 volt adjust (A22R12). The -15 volt supply must stay between -14.9 and -15.3 vdc.

- m. Vary line voltage from 103 to 127 vac. DC Voltmeter reading should not change more than ±0.4 vdc.
- n. Connect DC Voltmeter to A22 (14).
- p. DC Voltmeter should read +35 ±5 vdc.
- q. Disconnect front panel shorting bar.
- r. Connect AC Voltmeter between chassis ground and circuit common A22 (9).
- s. Use an insulated tuning wand to adjust A21C1 (located on bottom of chassis) for a minimum reading (refer to figure 5-8).

**5-15. 4.995 MC OSCILLATOR AND 9:1 DIVIDER  
 (A1) ADJUSTMENT.**

- a. Connect 10:1 probe of Oscilloscope to base of A1Q3 and ground lead to ground plane of oscillator board. (See figure 5-9.)
- b. Set Oscilloscope controls as follows:  
 INPUT . . . . . AC  
 SENSITIVITY . . . . . .05 V/CM  
 SWEEP TIME . . . . . 2 μSEC/CM
- c. Adjust A1T1 for maximum amplitude of 5 mc signal.
- d. Move 10:1 probe to emitter of A1Q3.
- e. Adjust A1L2 for eleven waveforms in 10 cm of horizontal deflection. Adjust A1L2 so that the first pip of signal is slightly larger than the rest (see figure 5-7, Waveforms 3 - 5).
- f. Repeat steps a thru e until optimum adjustment is obtained.
- g. Move probe to A1 (5).
- h. Adjust A1T2 for maximum amplitude of 555 kc signal.

5-16. ADJUSTABLE PHASE SHIFTER (A25)  
ADJUSTMENT.

## Note

The following procedure must be performed with printed board A2 in its normal operating position in the Model 203A. Do not use an extender board.

a. Connect AC Voltmeter across output of Phase Shifter Assembly (A25) using short unshielded leads (see figure 5-8).

b. While rotating PHASE LAG dial through 360° alternately adjust A2C1 (see figure 5-11) and A25C1 until voltage level indicated on AC Voltmeter remains with ±3% of nominal signal level obtained.

5-17. RF AMPLIFIER ADJUSTMENT (A2).

a. Connect DC Voltmeter to the collector of A2Q3; connect 10:1 Oscilloscope probe to collector of A2Q4. (See figure 5-11.)

b. Adjust A2L3 for maximum DC Voltmeter reading.

c. Adjust A2T1 for minimum AC voltage indication on Oscilloscope.

d. Repeat steps b and c as many times as necessary for optimum adjustment.

e. Connect DC Voltmeter to collector of A2Q7; connect 10:1 Oscilloscope probe to collector of A2Q8.

f. Adjust A2L7 for maximum DC Voltmeter reading.

g. Adjust A2T2 for minimum AC Voltage indication on Oscilloscope.

h. Repeat steps f and g as many times as necessary for optimum adjustment.

5-18. DECADE MODULE A11 ADJUSTMENT.

## Note

Each of the six Decade Modules, A11 through A16 are electrically identical. Each module should be adjusted in the 1K position of the range switch for best results. All components are referred to by their location on the module. For example, L1 is A11L1, A12L1, A13L1, etc. depending upon the particular module under test. Module A11 procedure is given separately because of its wide frequency range.

a. Connect a 10:1 Oscilloscope probe to the junction of CR1 and CR2 (see figure 5-13b) and see the controls as follows:

SENSITIVITY	.02v/cm
SWEEP TIME	2 usec/cm
TRIGGER SOURCE	INT

b. Set the frequency dial to 5 and the range switch to 1K.

c. Adjust T1 and L1 for maximum amplitude of the 5 mc signal.

## Note

L1 may have two peaks. The correct position of the slug is the second peak in the clockwise direction. The wrong position of the slug will be noted by a sawtooth waveform.

d. Move the 10:1 Oscilloscope probe to the base of Q3 and change the vertical sensitivity to .05v/cm.

e. Adjust T2 for maximum amplitude of the 5 mc signal.

f. Move the 10:1 Oscilloscope probe to the emitter of Q3.

g. Adjust L2 for eleven complete cycles in 10 cm of horizontal deflection. (See figure 5-7, waveform 12.)

h. Move the 10:1 Oscilloscope probe to the base of Q3.

i. Rotate the frequency dial slowly to the high end. The amplitude of the 5 mc signal should not fall below 1 cm (.5v p-p.)

j. If the signal at the high end of the dial is too low in amplitude, turn L1 slug counterclockwise until 1 cm of amplitude is obtained. Rotate the frequency dial from the high end to the low end and stagger tune L1 and T1 as necessary in order to maintain at least 1 cm of amplitude over the entire range.

k. Move the 10:1 Oscilloscope probe to the emitter of Q3 and set the frequency dial to 5.

l. Turn L2 slug clockwise until the waveform goes out of sync. Next turn L2 slug counterclockwise until the waveform just comes back into sync.

m. Rotate the frequency dial slowly toward the high end until the waveform goes out of sync.

n. Turn L2 slug counterclockwise until the waveform just comes back into sync.

o. Repeat steps m and n until the waveform is synchronized while rotating the dial between the extreme high and low ends.

p. Rotate the frequency dial until the first pip on the waveform is at maximum amplitude.

q. Turn L2 slug counterclockwise to reduce the amplitude of the first pip to one-half the amplitude noted in step p. The bottom of the first pip will be slightly lower in amplitude than any other part of the waveform.



5-19. MODULE A12 THROUGH A16  
ADJUSTMENTS.

a. Connect the 10:1 oscilloscope probe to the junction of CR1 and CR2 (see figure 5-13b) and set the controls as follows:

SENSITIVITY	.02v/cm
SWEEP TIME	2 usec/cm
TRIGGER SOURCE	INT

b. Set the frequency dial to any position and the range switch to the 1K position. (The reason for this setting is that the frequency range of these decades is small.

c. Adjust T1 and L1 for maximum 5 mc signal (see figure 5-7, waveform 8.)

d. Move the 10:1 oscilloscope probe to the base of Q3 and change the vertical sensitivity to .05v/cm.

e. Adjust T2 for maximum amplitude of the 5 mc signal.

f. Move the 10:1 oscilloscope probe to the emitter of Q3.

g. Adjust L2 for eleven complete cycles in 10 cm of horizontal deflection.

h. Rotate L2 slug clockwise until the waveform goes out of sync and then turn L2 counterclockwise until the waveform just comes back into sync. Note the amplitude of the first pip at the bottom of the waveform. Turn L2 slug counterclockwise until the amplitude of the first pip is reduced by one half.

5-20. FREQUENCY DIAL ADJUSTMENT.

a. Connect Model 203A as shown in figure 5-1. Adjust the dial to a precise setting of 6.

b. Set MULTIPLIER switch to 1K.

c. Set 6 on the dial exactly on the period count of  $1667 \pm 2$  counts. Thus the quick Calibration Feature (paragraph 4-56) should bring the entire range into specifications.

d. Check each FREQUENCY dial setting listed in table 5-2. If at any point the frequency lies outside the specified tolerance, adjust C11 by carefully bending its outer plates until the frequency is within the given tolerance. Check 6 on the dial again to be sure that it is exactly on frequency.

5-21. MODULATOR (A3) ADJUSTMENT.

a. Connect DC Voltmeter to A3 (12). (See figure 5-15.)

b. Adjust A3R13 for minimum DC Voltmeter reading (typically between +50 and -50 millivolts.)

c. Measure voltage at A3 (4); reading should not exceed 250 mv.

5-22. DISTORTION.

a. Connect Distortion Analyzer and 600 ohm 1% resistor, -hp- #0727-0081) to REFERENCE PHASE ~ OUTPUT terminals.

b. Set FREQUENCY dial to 5; MULTIPLIER to 1K.

c. Set PHASE LAG dial to obtain maximum distortion reading on Distortion Analyzer.

d. Adjust A3R17 for minimum distortion. (See figure 5-15.)

e. Connect Distortion Analyzer and 600 ohm resistor to VARIABLE PHASE ~ OUTPUT terminals.

f. Set PHASE LAG dial to obtain maximum distortion reading.

g. Adjust A3R31 for minimum distortion.

Note

Perform steps h thru r only if distortion is greater than -64 db (0.06%) below reference level. These steps will reduce only excessive eighth and tenth harmonics.

h. Check and adjust as necessary, modules A11 through A14 according to Table 5-4. In each case a 10:1 oscilloscope probe is connected to the base of Q3 and a minimum signal amplitude of .5v p-p should be maintained for proper circuit operation.

Table 5-4

MODULE	RANGE	DIAL	MAXIMUM DISTORTION	IF<-64DB ADJUST
A11	X100	5	> -64 db	T1
A11	X100	50	> -64 db	L1
A12	X10	5	> -64 db	T1
A13	X1	5	> -64 db	T1
A14	X.1	50	> -64 db	T1

5-23. FREQUENCY RESPONSE.

a. Connect DC Voltmeter to REFERENCE PHASE ~ OUTPUT terminals.

b. Set FREQUENCY dial to 50, MULTIPLIER to 100 and both ~ AMPLITUDE controls fully clockwise.

c. Adjust A6R8 (A7R8 for VARIABLE PHASE) (DC Zero Adj) for minimum DC Voltmeter reading (typically between +20 and -20 millivolts). See figure 5-17.)

d. Disconnect DC Voltmeter.

Note

Do not place DC Amplifiers (A6 and A7) on extender board.

g. Set REFERENCE PHASE ~ AMPLITUDE for AC voltmeter reading of 4.9 vac.



DO NOT EXCEED 7.5 MV OUTPUT AS THERMAL CONVERTER IS VERY EASILY DAMAGED BY EXCESSIVE INPUT VOLTAGE.

h. Disconnect AC Voltmeter.

i. Carefully adjust REFERENCE PHASE ~ AMPLITUDE for a DC Voltmeter reading of 7.0 millivolts.

k. Set Model 203A MULTIPLIER switch to 1.

m. Adjust A3R20 (A3R34 for VARIABLE PHASE) (50 cps adj) until the DC Voltmeter reads 7.0 millivolts.

n. Set MULTIPLIER switch to 10. Note DC Voltmeter reading.

p. Set MULTIPLIER switch to 1K.

q. Adjust A4R2 (A5R2 for VARIABLE PHASE) (50 kc adj) until DC Voltmeter reads the same as in step j.

r. Repeat steps j thru q until readings at 50 cps, 500 cps and 50 kc are between 6.93 and 7.07 millivolts.

s. Repeat steps a thru r for the VARIABLE PHASE ~ OUTPUT.

t. Disconnect Thermal Converter and connect AC VTVM to REFERENCE PHASE ~ OUTPUT terminals. Set REFERENCE PHASE ~ AMPLITUDE fully clockwise.

u. Adjust A6R20 (A7R20 for VARIABLE PHASE) AMP. Adj for 10.6 volts.

v. Repeat steps t and u for the VARIABLE PHASE ~ OUTPUT.

5-24. PHASE LAG DIAL.

a. Connect Model 203A as shown in figure 5-6.

b. Set FREQUENCY dial to 10; MULTIPLIER switch to 100. Set both ~ AMPLITUDE controls fully clockwise.

c. Adjust PHASE LAG dial and one (not both) of the ~ AMPLITUDE controls for minimum reading on AC Voltmeter. Typical reading is less than 50 mv.

d. Loosen set screws and slip PHASE LAG dial until it reads exactly 180° at the null obtained in step c and then tighten the set screws.

Note

If a phase error is noted at different points on the dial, it may be necessary to slip the dial in order to minimize any errors.

5-25. SQUARE WAVE (A8 and A9) ADJUSTMENT.

a. Connect DC Voltmeter to Model 203A REFERENCE PHASE ~ OUTPUT.

b. Set Model 203A controls as follows:

FREQUENCY . . . . . 10  
MULTIPLIER . . . . . 100  
~ AMPLITUDE . . . . . both CW

c. Adjust A8R9 for a minimum reading on dc voltmeter (typically between +50 and -50 millivolts). (See figure 5-17.)

d. Connect dc voltmeter to VARIABLE PHASE OUTPUT.

e. Adjust A9R9 for a minimum reading on dc voltmeter (typically between +50 and -50 millivolts).

5-26. TROUBLESHOOTING.

5-27. To locate trouble in the Model 203A, start with a thorough visual inspection of the instrument. Look for burned out or loose components and connections, and other similar conditions which suggest a source of trouble. For further aid in troubleshooting use Model 203A Block Diagram (figure 4-1), Purpose for Factory Selected Values (table 5-5), Troubleshooting Summary (table 5-6), and Typical Waveforms (figure 5-7).

5-28. PRINTED CIRCUIT BOARD REPAIR.

5-29. The Model 203A uses plated through double-sided etched circuit boards.

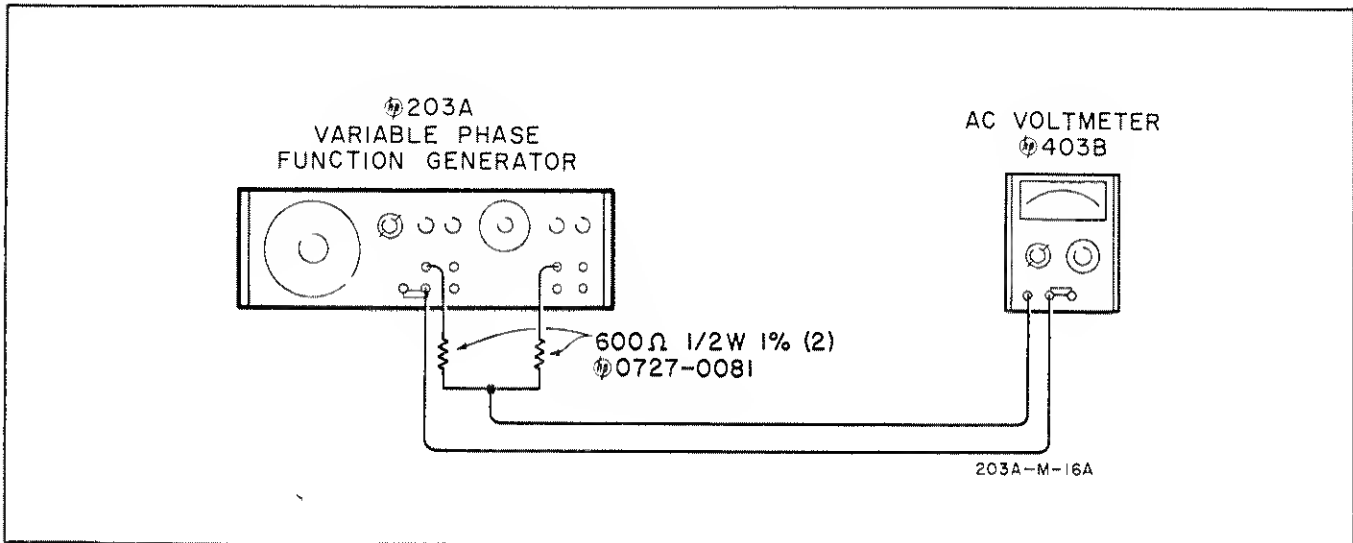

Figure 5-6. Phase Lag Dial Adjustment

5-30. Observe the following rules when repairing double-sided etched circuit boards.

- a. Solder from the conductor side of the etched circuit board.
- b. Avoid applying excessive heat when soldering on the circuit board.

c. To remove a damaged component, clip component leads near the component; then apply heat and remove each lead with a straight upward motion.

d. Use a special tool to remove components having multiple connections, such as potentiometers, etc. Refer to table 5-1 for type of soldering tip required.

e. Use a toothpick to free hole of solder before installing a new component.

Table 5-5. Purpose of Factory Selected Values

A2C2*	To provide proper range for A2C1. (Adjust only if A25, A2Q1 or A2Q2 are changed.)
A2C7*	To provide proper amplitude for 90° A25 drive. (Adjust only if A25, A2Q1 or A2Q2 are changed.)
A2C11*	To provide proper amplitude for 0° A25 drive. (Adjust only if A25, A2Q1 or A2Q2 are changed.)
A3R5*	Value very seldom changed. Adjust drive amplitude for A3Q2.
A21C2*	To provide common ground isolation.
A22C2*	To eliminate H. F. oscillations on the -24.5 volt dc supply.
A22C12*	To eliminate H. F. oscillations on the -15 volt dc supply.
C12*	Do not change unless absolutely necessary! Coarse adjustment for 5 kc.

Table 5-6. Troubleshooting Summary

Symptoms	Possible Cause
<p>1. No output on any channel</p>	<p>① Check: VFO output at XA10 pins 4 and 6 (X1K range).                      ② If no output, check 555 kc output XA1 pins 5 and 6.                      ③ If no output at ②, check 4.995 Mc output XA1 pin 1.                      ④ Check power supply voltages and continuity between circuit ground and chassis. If output is at ② but not at ①, check:                      a. A10L1, L2 for open.                      b. A10C11, C15 for short.                      c. A10C5, C8 for open.                      ⑤ If output is at ③ but not at ②, check:                      a. Open windings in A1T1, T2 or L2.                      b. Low beta of A1Q3 or Q4.                      ⑥ If no output at ③, check: ④ and crystal Y1, transistor A1Q1</p>
<p>2. Output on one channel only (sine and square)</p>	<p>① Check: output at pins 2 and 4 of XA6 or XA7.                      ② If no output, check pins 12 or 4 of XA3.                      ③ If output is at ② but not ①, check:                      a. A4 or A5 at pin 6 then pin 1.                      b. L1, L2 or L3 might have case grounded.                      ④ If output is at ③ but not at pin 4 of XA3, check:                      a. A3Q9, T2, T4 for open.                      b. Misadjustment of A3R31 or R34.                      ⑤ If output is at ③ but not at pin 12 of XA3, check:                      a. A3Q4, T1 or T3 for open.                      b. Misadjustment of A3R17 or R20.</p>
<p>3. No square wave output</p>	<p>① Check: Input pin 1 of XA8 or XA9.                      ② If no signal, check output pin 2 of XA6 or XA7.                      ③ If signal is at ①, check output pin 6 of XA8 or XA9.                      ④ If signal is at ① but not ③, check:                      a. A8Q5, Q4 or CR1 for open.                      b. A9Q5, Q4 or CR1 for open.</p>
<p>4. No output on variable channel (sine and square)</p>	<p>① Check: output of RF Amplifier pin 7 of XA2.                      ② If no signal at ①, check input pin 4 of XA2.                      ③ If no signal at ②, check pins 3 and 14 of XA2.                      ④ If output is at ③ but not at ②, check components in A25.                      ⑤ If no output at ①, no output at ②, check components listed under second symptom.</p>
<p>5. High Distortion on one frequency range</p>	<p>① Adjust Decade Divider for that range. Use procedure in paragraph 5-18/5-19</p>
<p>6. Distortion on REF Sine OUTPUT varies as PHASE LAG dial is rotated</p>	<p>① Defective A2Q1 or A2Q2.</p>

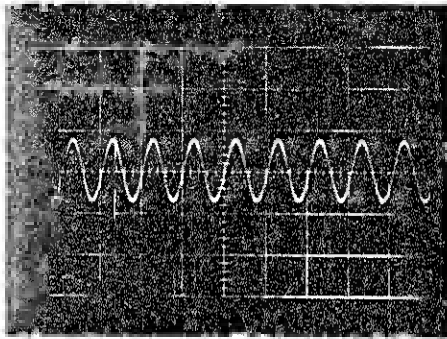

1- A1 (1) 5 mc output  
.5 V/CM; .2  $\mu$ SEC/CM

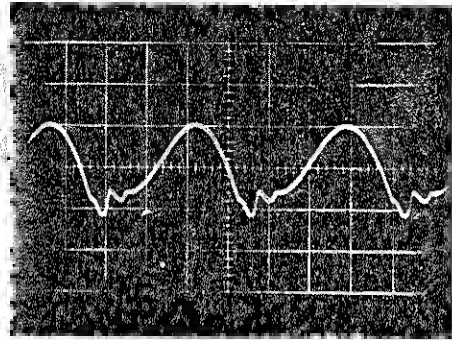

4- A1Q3 Emitter  
A1L2 minimum for synchronization  
.5 V/CM; .5  $\mu$ SEC/CM

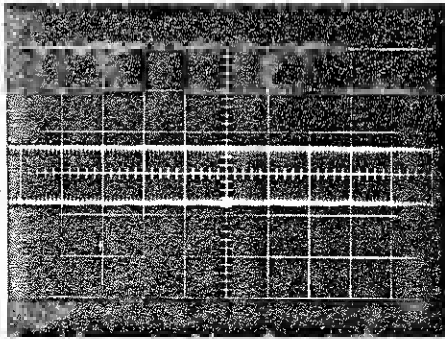

2 - A1Q3 Base  
.5 V/CM; 2  $\mu$ SEC/CM

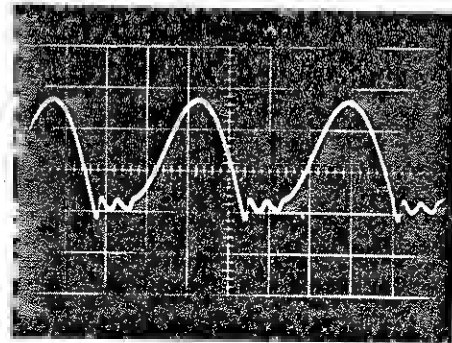

5- A1Q3 Emitter  
A1L2 nominal  
.5 V/CM; .5  $\mu$ SEC/CM

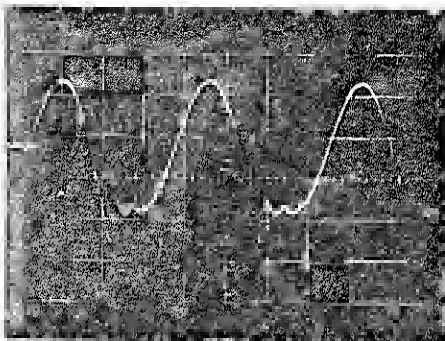

3- A1Q3 Emitter  
A1L2 maximum for synchronization  
.5 V/CM; .5  $\mu$ SEC/CM

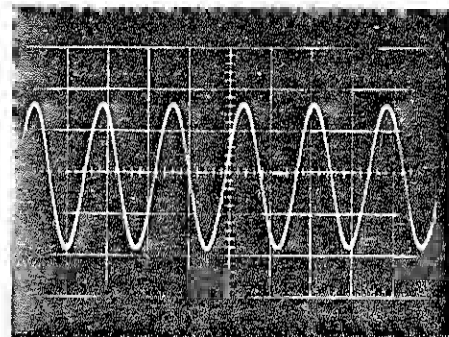

6- A2 (11) RF Amp Output  
1 V/CM; 1  $\mu$ SEC/CM

Figure 5-7. Typical Waveforms (Page 1 of 3)

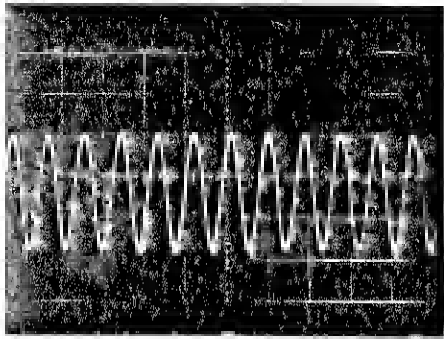

7- A10 (6) VFO Output  
.5 V/CM; 2  $\mu$ SEC/CM

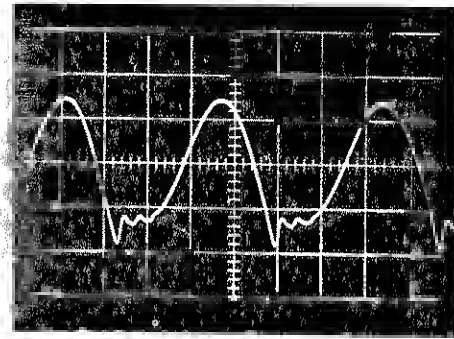

10- A11Q3 Emitter  
L2 maximum for synchronization  
.5 V/CM; .5  $\mu$ SEC/CM

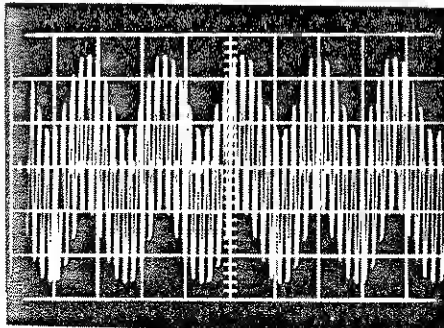

8- A11-Junction CR1 and CR2  
.5 V/CM; 1  $\mu$ SEC/CM

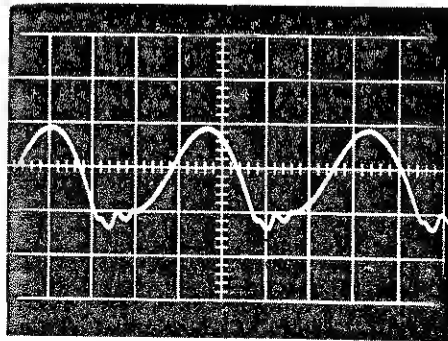

11- A11Q3 Emitter  
L2 minimum for synchronization  
.5 V/CM; .5  $\mu$ SEC/CM

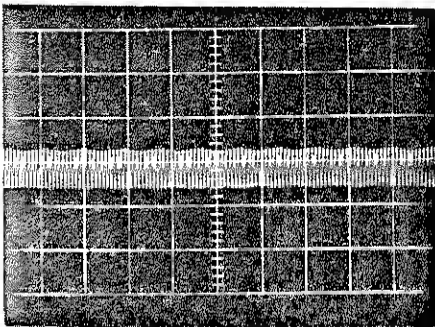

9- A11Q3 Base  
.5 V/CM; 2  $\mu$ SEC/CM

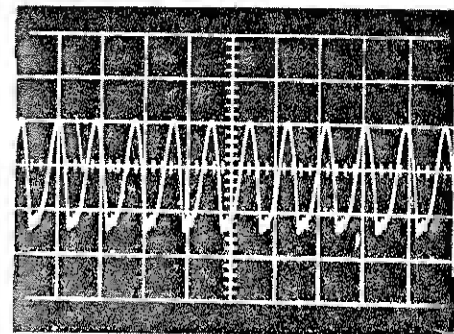

12- A11Q3 Emitter  
L2 nominal  
.5 V/CM; 2  $\mu$ SEC/CM

Figure 5-7. Typical Waveforms (Page 2 of 3)

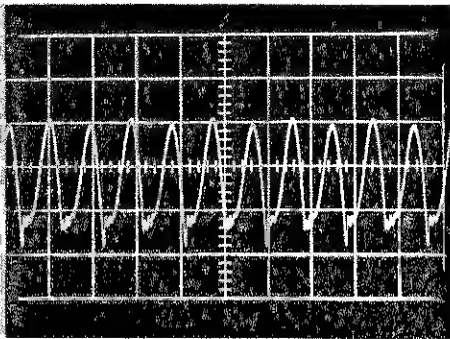

13- A11Q3 Emitter  
Incorrect Frequency Division  
.5 V/CM; 2  $\mu$ SEC/CM

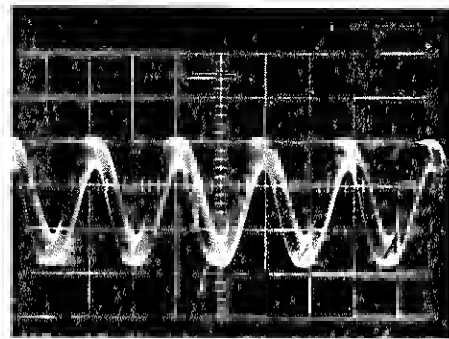

16- A3 (12) Modulator Output  
FREQUENCY - 5 kc  
.5 V/CM; .1 MSEC/CM



14- A3Q3 Collector  
.5 V/CM; .5  $\mu$ SEC/CM

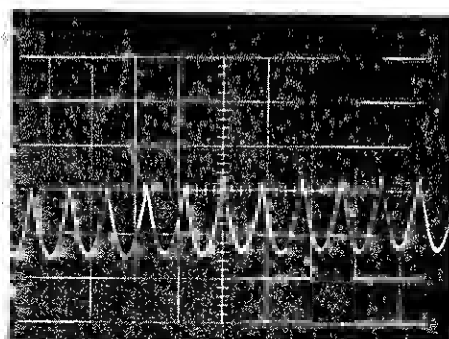

17- A3 (12) Modulator Output  
FREQUENCY - 5 kc  
.5 V/CM; 1  $\mu$ SEC/CM

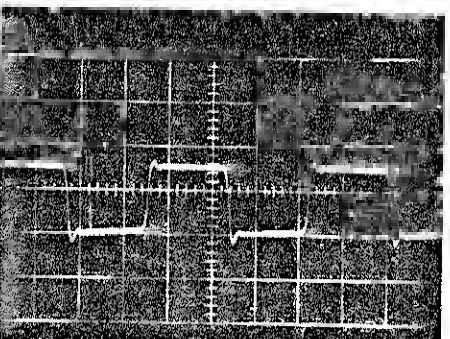

15- A3Q5 Base  
.5 V/CM; .5  $\mu$ SEC/CM



18- A8Q4 Collector  
FREQUENCY - 1 kc  
5 V/CM; .2  $\mu$ SEC/CM

Figure 5-7. Typical Waveforms (Page 3 of 3)

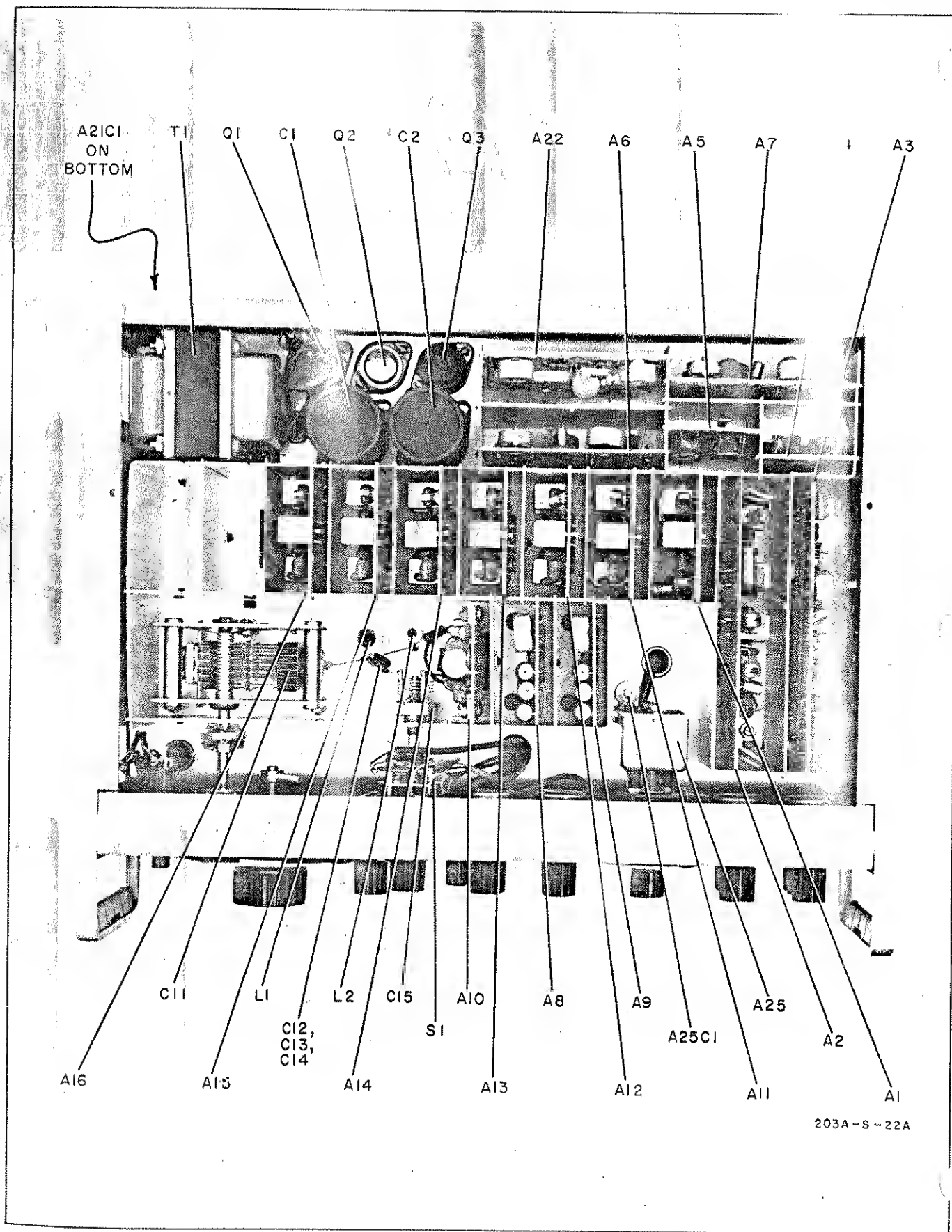

203A-S-22A

Figure 5-8. Chassis - Top View



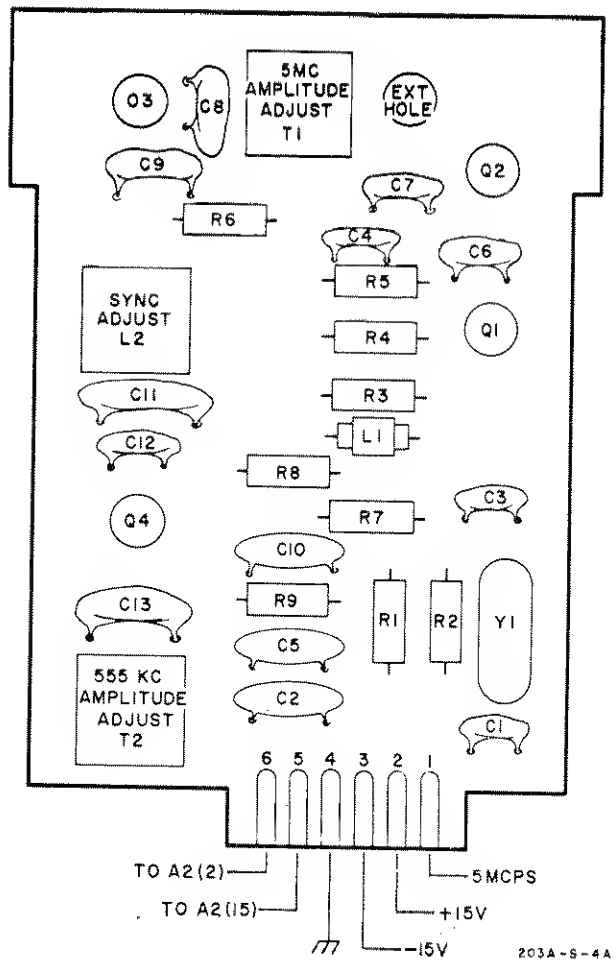
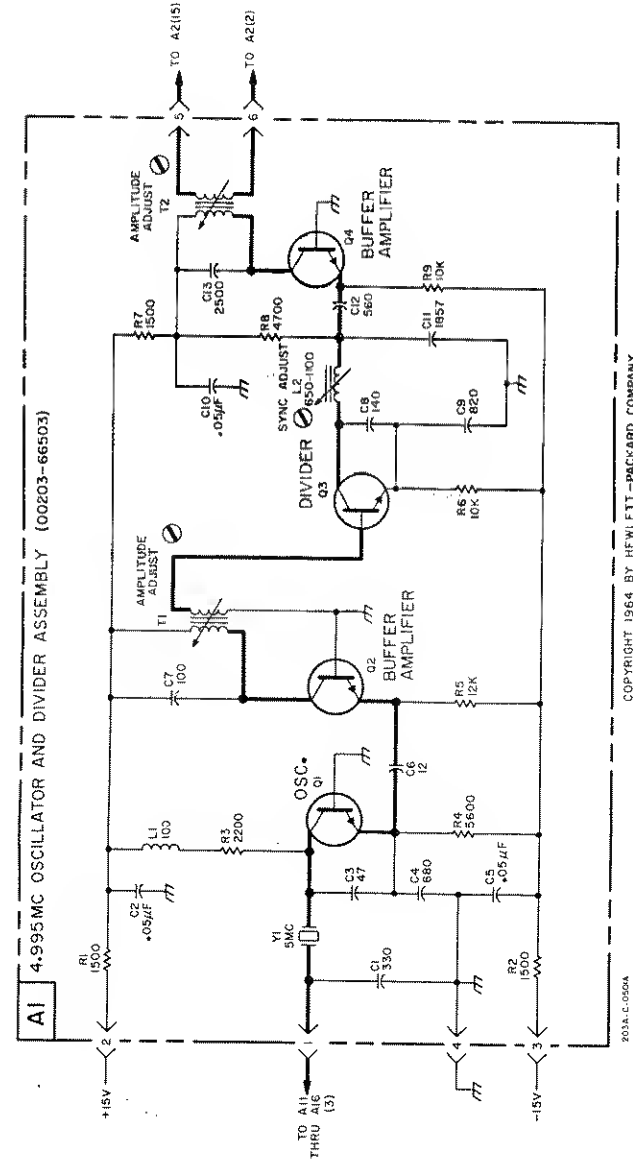

Figure 5-9. 5 Mc Oscillator and 9:1 Divider Assy A1--Component Location



- NOTES**
1. PARTIAL REFERENCE DESIGNATIONS ARE SHOWN. PREFIX WITH ASSEMBLY OR SUB-ASSEMBLY DESIGNATION(S) OR BOTH FOR COMPLETE DESIGNATION.
  2. COMPONENT VALUES ARE SHOWN AS FOLLOWS UNLESS OTHERWISE NOTED:  
RESISTANCE IN OHMS  
CAPACITANCE IN PICOFARADS  
INDUCTANCE IN MICROHENRYS
  3. --- DENOTES ASSEMBLY.
  4. --- DENOTES MAIN SIGNAL PATH.
  5. Ⓢ DENOTES SCREWDRIVER ADJUST.
  6. Ⓜ DENOTES CIRCUIT (FLOATING) GROUND.

COPYRIGHT 1964 BY HEWLETT-PACKARD COMPANY

203A.C.0504

Figure 5-10. 5 Mc Oscillator and 9:1 Divider Assembly A1 -- Schematic

### NOTES

1. PARTIAL REFERENCE DESIGNATIONS ARE SHOWN; PREFIX WITH ASSEMBLY OR SUBASSEMBLY DESIGNATION(S) OR BOTH FOR COMPLETE DESIGNATION.
2. COMPONENT VALUES ARE SHOWN AS FOLLOWS UNLESS OTHERWISE NOTED:  
 RESISTANCE IN OHMS  
 CAPACITANCE IN PICOFARADS
3.  DENOTES ASSEMBLY.
4.  DENOTES MAIN SIGNAL PATH.
5.  DENOTES FEEDBACK PATH.
6.  DENOTES SCREWDRIVER ADJUST.
7. \* AVERAGE VALUE SHOWN, OPTIMUM VALUE SELECTED AT FACTORY.
8.  DENOTES CIRCUIT (FLOATING) GROUND.

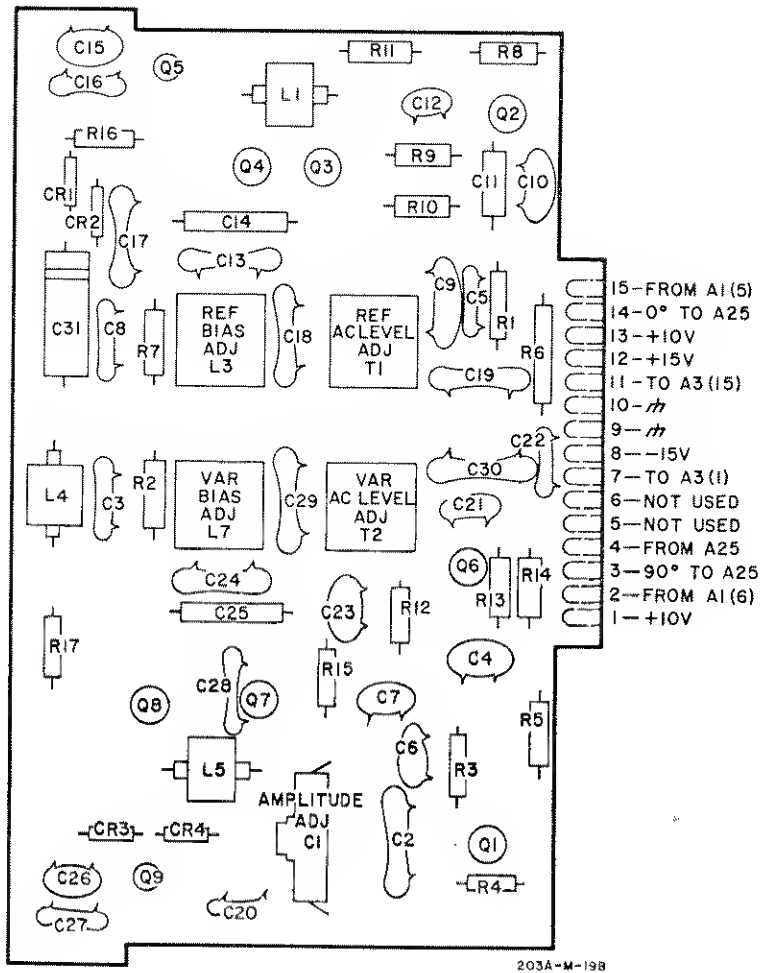
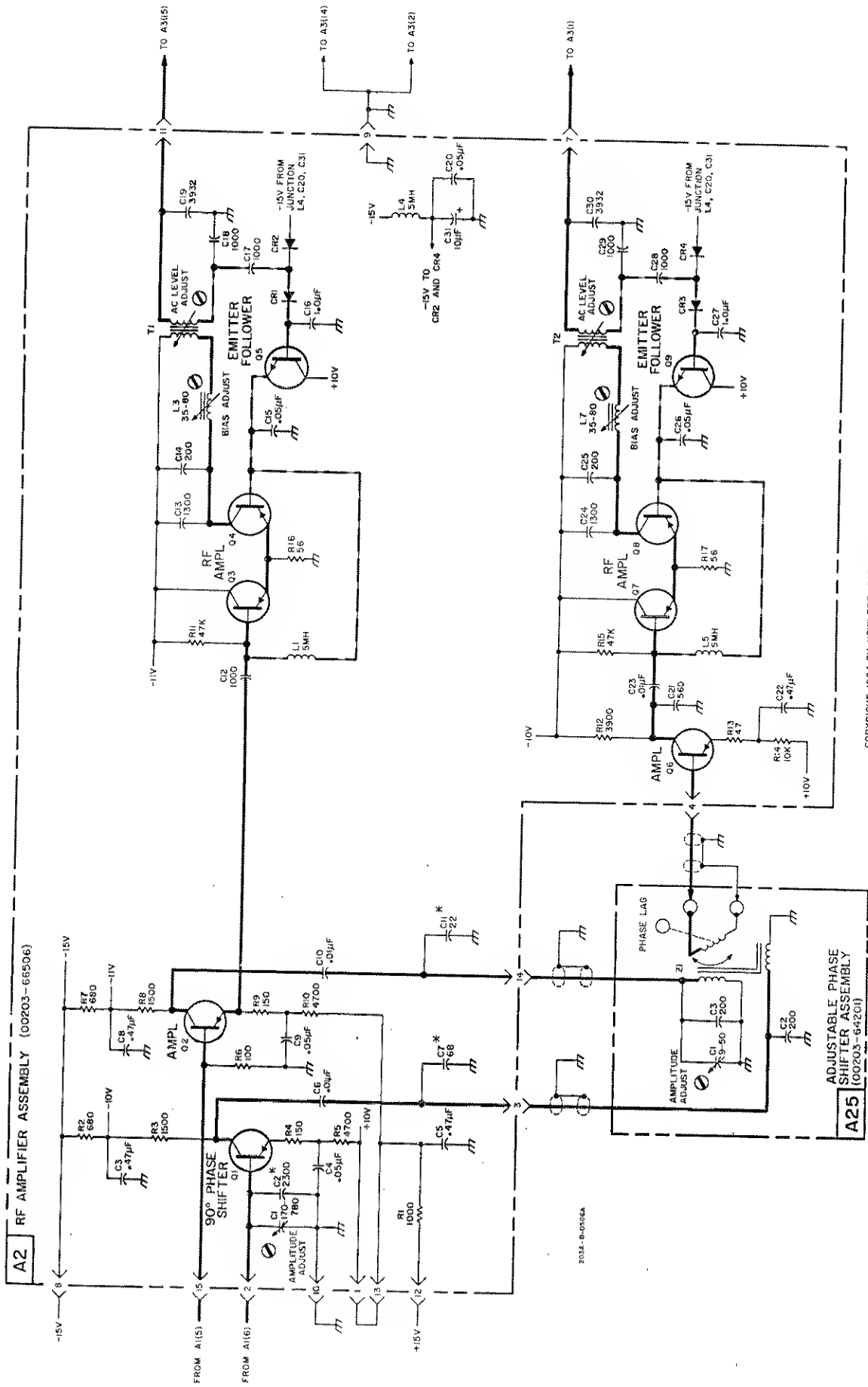
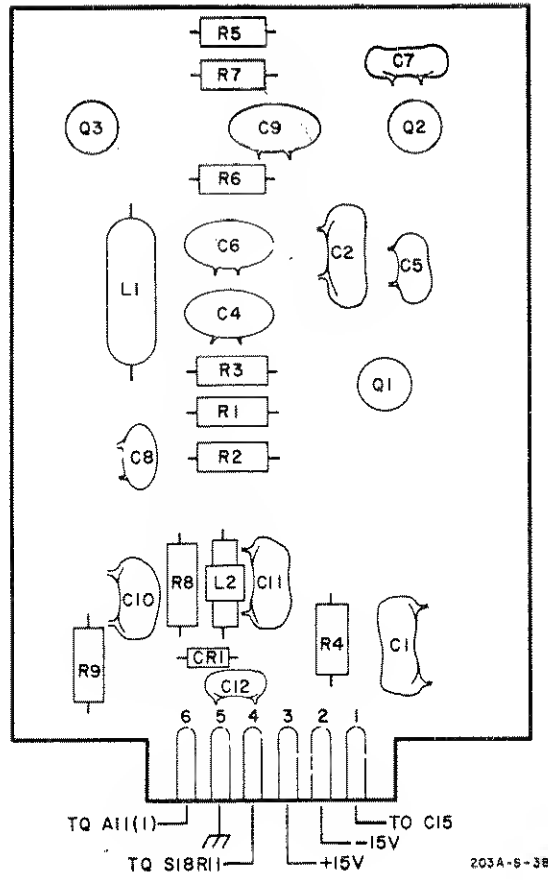

Figure 5-11. RF Amplifier Assy A2--Component Location



COPYRIGHT 1964 BY HEWLETT-PACKARD COMPANY

Figure 5-12. RF Amplifier Assy A2 and Adjustable Phase Shifter Assy A25 -- Schematic



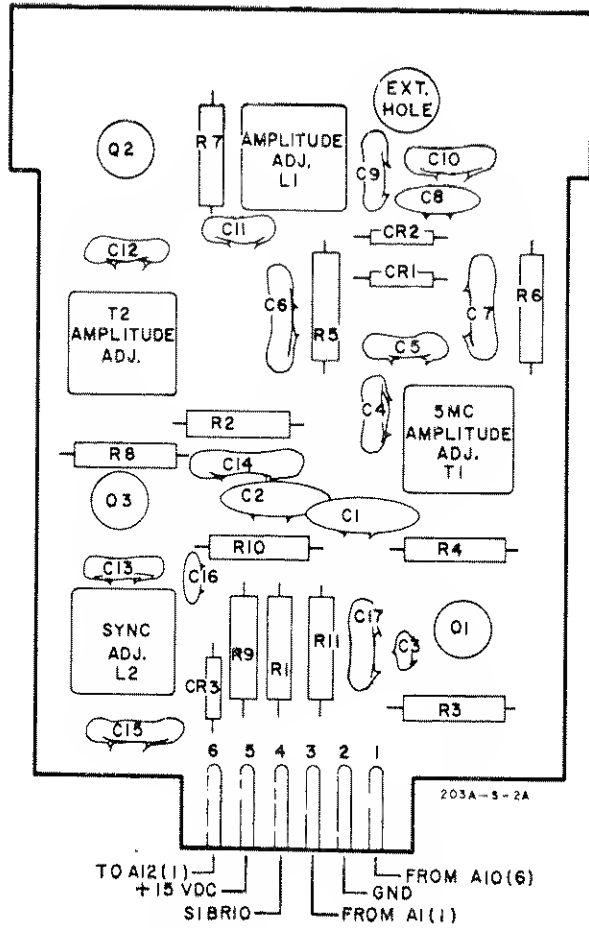
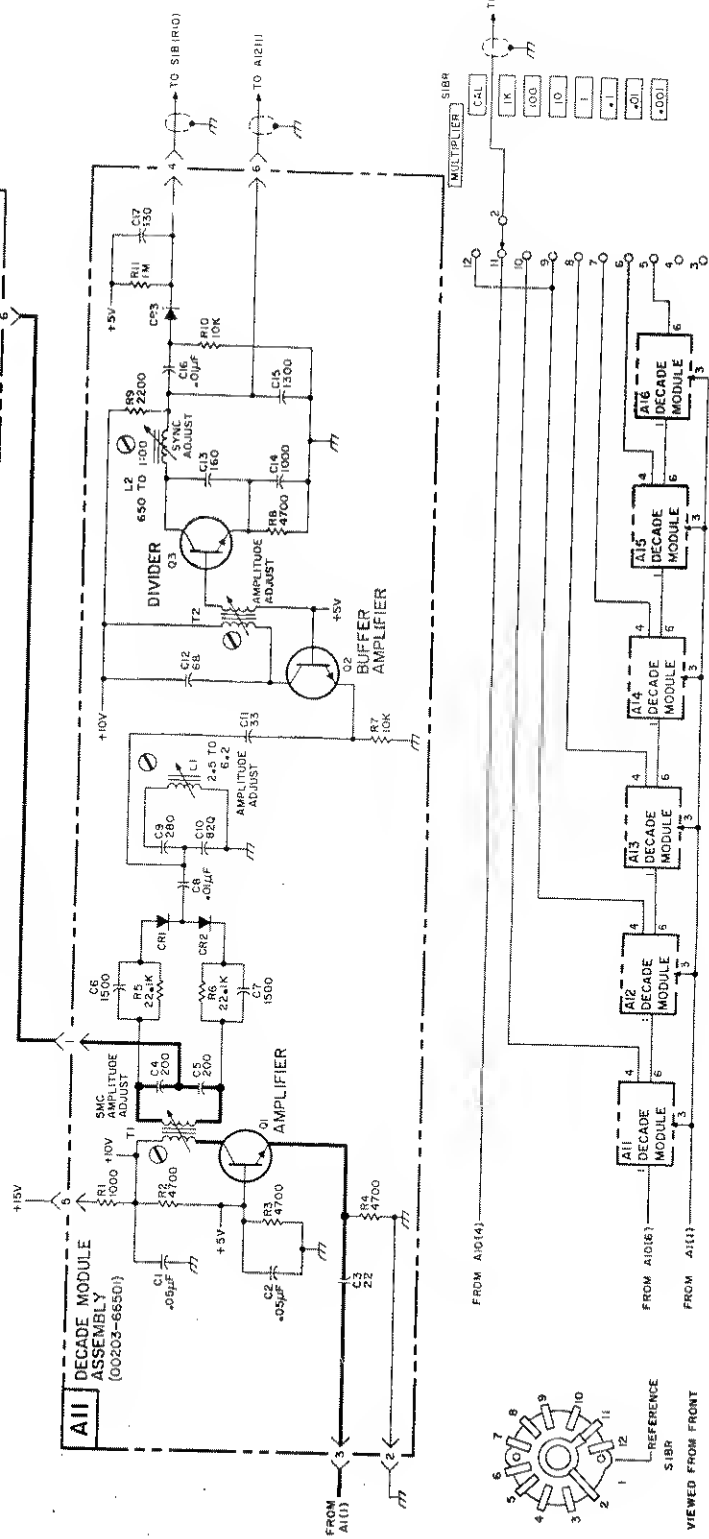
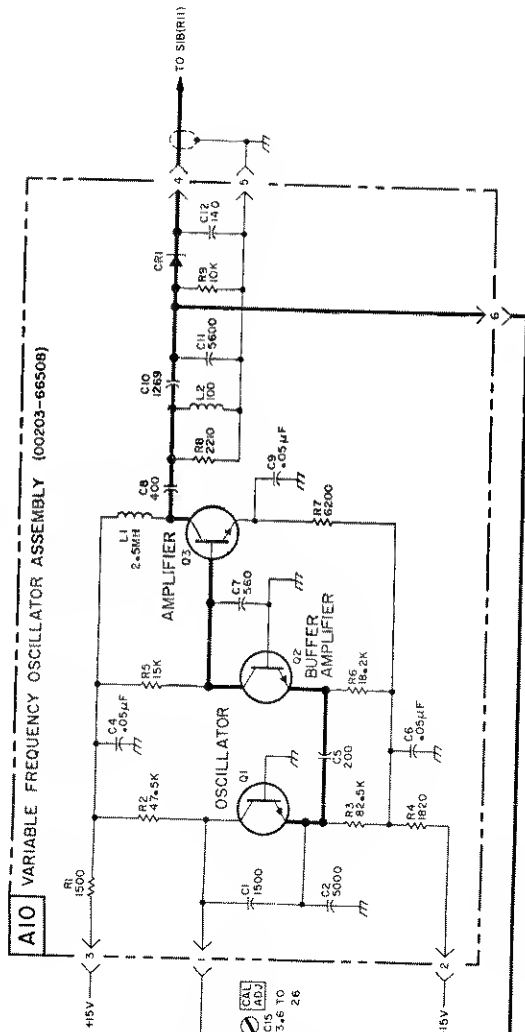
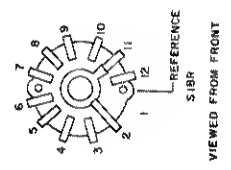
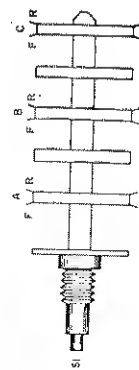

Figure 5-13b. Decade Module Assy A11--Component Location



NOTES

1. PARTIAL REFERENCE DESIGNATIONS ARE SHOWN. PREFIX WITH ASSEMBLY OR SUBASSEMBLY DESIGNATION(S) OR BOTH FOR COMPLETE DESIGNATION.
2. COMPONENT VALUES ARE SHOWN AS FOLLOWS UNLESS OTHER-WISE NOTED:  
RESISTANCE IN OHMS  
CAPACITANCE IN PICOFARADS  
INDUCTANCE IN MICROHENRYS
3. \_\_\_\_\_ DENOTES ASSEMBLY.
4. \_\_\_\_\_ DENOTES MAIN SIGNAL PATH.
5. \_\_\_\_\_ DENOTES FRONT PANEL MARKING.
6. \_\_\_\_\_ DENOTES SCREWDRIIVER ADJUST.
7. \* AVERAGE VALUE SHOWN. OPTIMUM VALUE SELECTED AT FACTORY.
8. \_\_\_\_\_ DENOTES CIRCUIT GROUND (FLOATING).



COPYRIGHT 1964 BY HEWLETT-PACKARD COMPANY

203A-0-05024

Figure 5-14. VFO Assy A10 and Decade Module Assy A11 to A16--Schematic

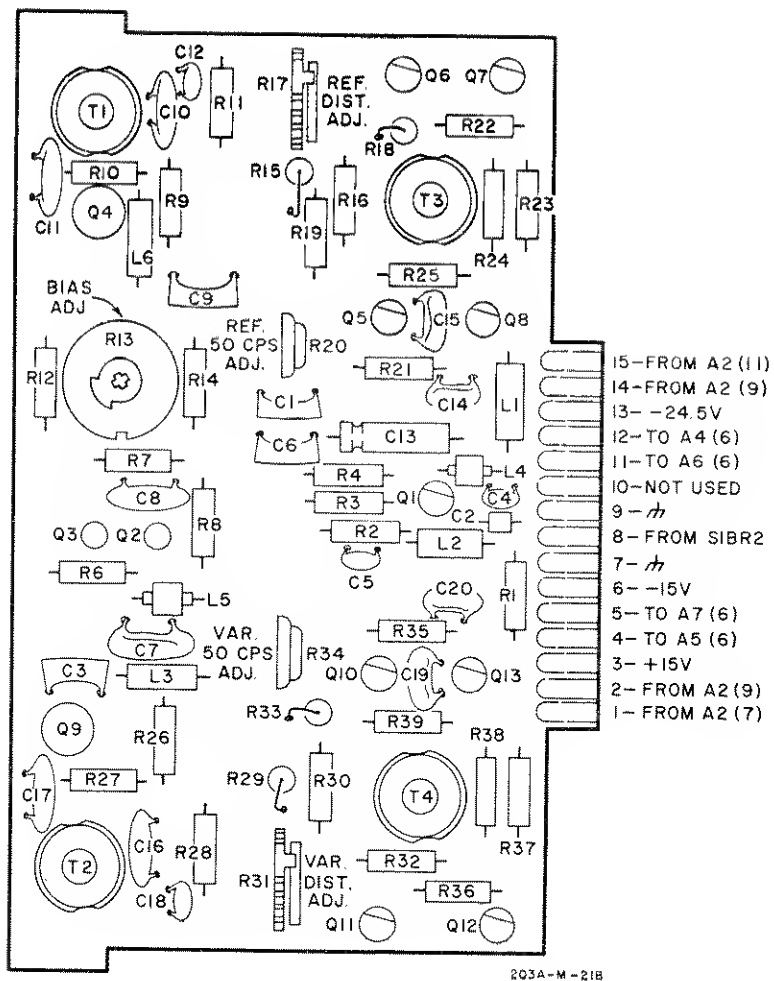
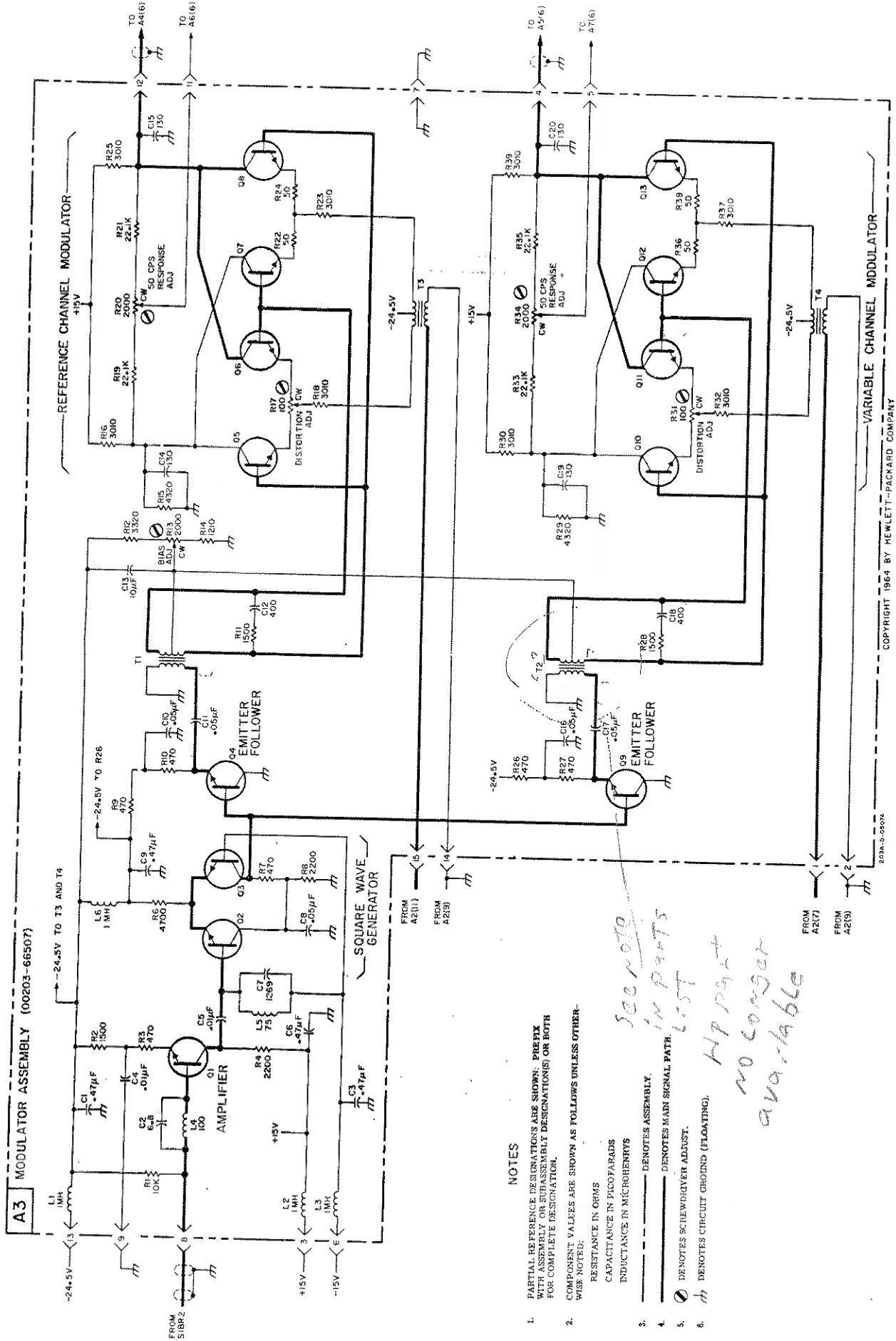

Figure 5-15. Modulator Assy A3--Component Location





**NOTES**

- PARTIAL REFERENCE DESIGNATIONS ARE SHOWN. PREFIX WITH ASSEMBLY OR SUBASSEMBLY DESIGNATION(S) OR BOTH FOR COMPLETE DESIGNATION.
- COMPONENT VALUES ARE SHOWN AS FOLLOWS UNLESS OTHERWISE NOTED:  
RESISTANCE IN OHMS  
CAPACITANCE IN PICO FARADS  
INDUCTANCE IN MICROHENRYS
- DENOTES ASSEMBLY.
- DENOTES MAIN SIGNAL PATH.
- ⊗ DENOTES SCREWDRIVER ADJUST.
- ⏏ DENOTES CIRCUIT GROUND (FLOATING).

*See note in parts list*  
*HP part no longer available*

### NOTES

1. PARTIAL REFERENCE DESIGNATIONS ARE SHOWN: PREFIX WITH ASSEMBLY OR SUBASSEMBLY DESIGNATION(S) OR BOTH FOR COMPLETE DESIGNATION.
2. COMPONENT VALUES ARE SHOWN AS FOLLOWS UNLESS OTHERWISE NOTED:  
 RESISTANCE IN OHMS  
 CAPACITANCE IN PICOFARADS  
 INDUCTANCE IN MICROHENRYS
3. DENOTES SUBASSEMBLY.
4. DENOTES MAIN SIGNAL PATH.
5. DENOTES FEEDBACK PATH.
6. DENOTES FRONT PANEL MARKING.
7. DENOTES SCREWDRIVER ADJUST.
8. \* AVERAGE VALUE SHOWN, OPTIMUM VALUE SELECTED AT FACTORY.
9. DENOTES CIRCUIT GROUND (FLOATING).

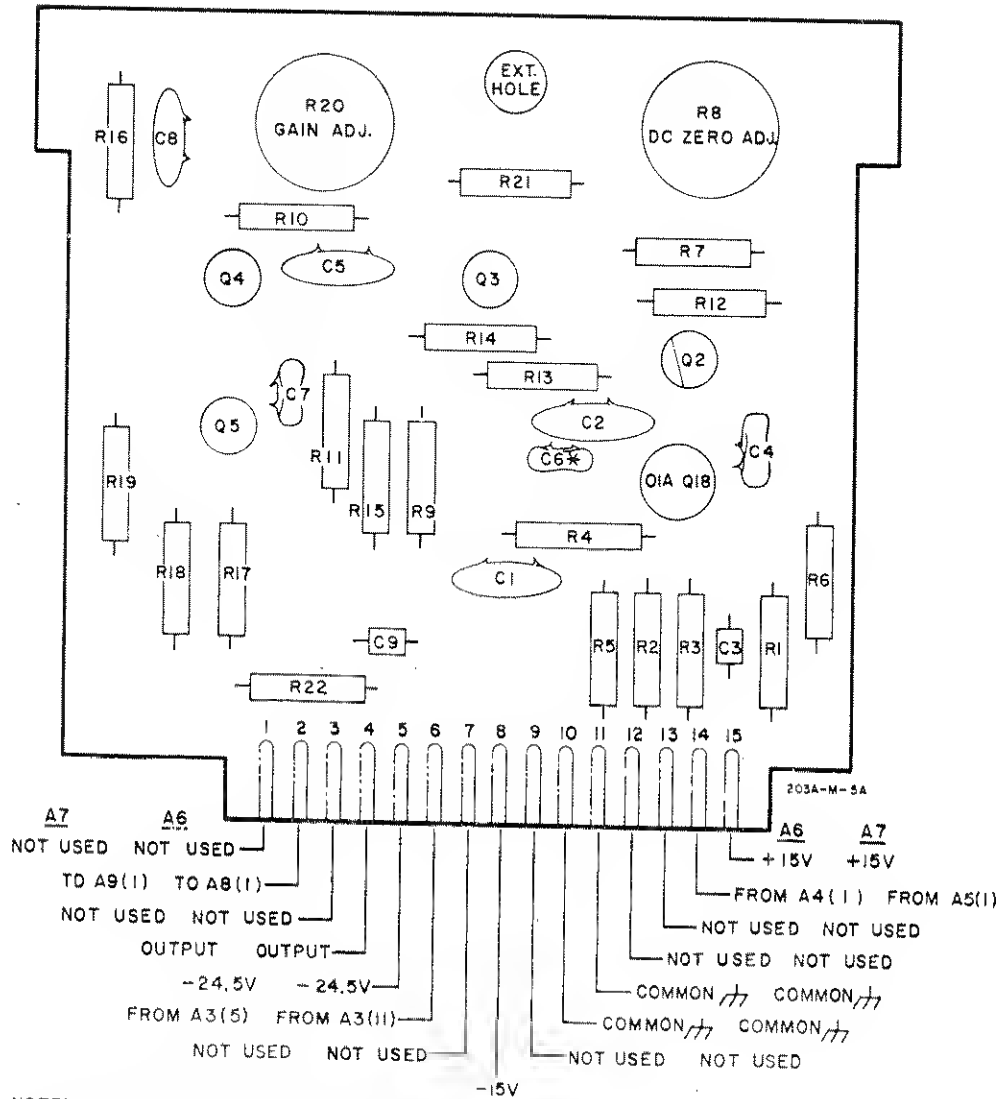

NOTE: A6 AND A7 BOARDS ARE IDENTICAL.  
 CHANGE PIN CONNECTIONS AS LISTED.

Figure 5-17. DC Amplifier Assy A6 and A7--Component Location

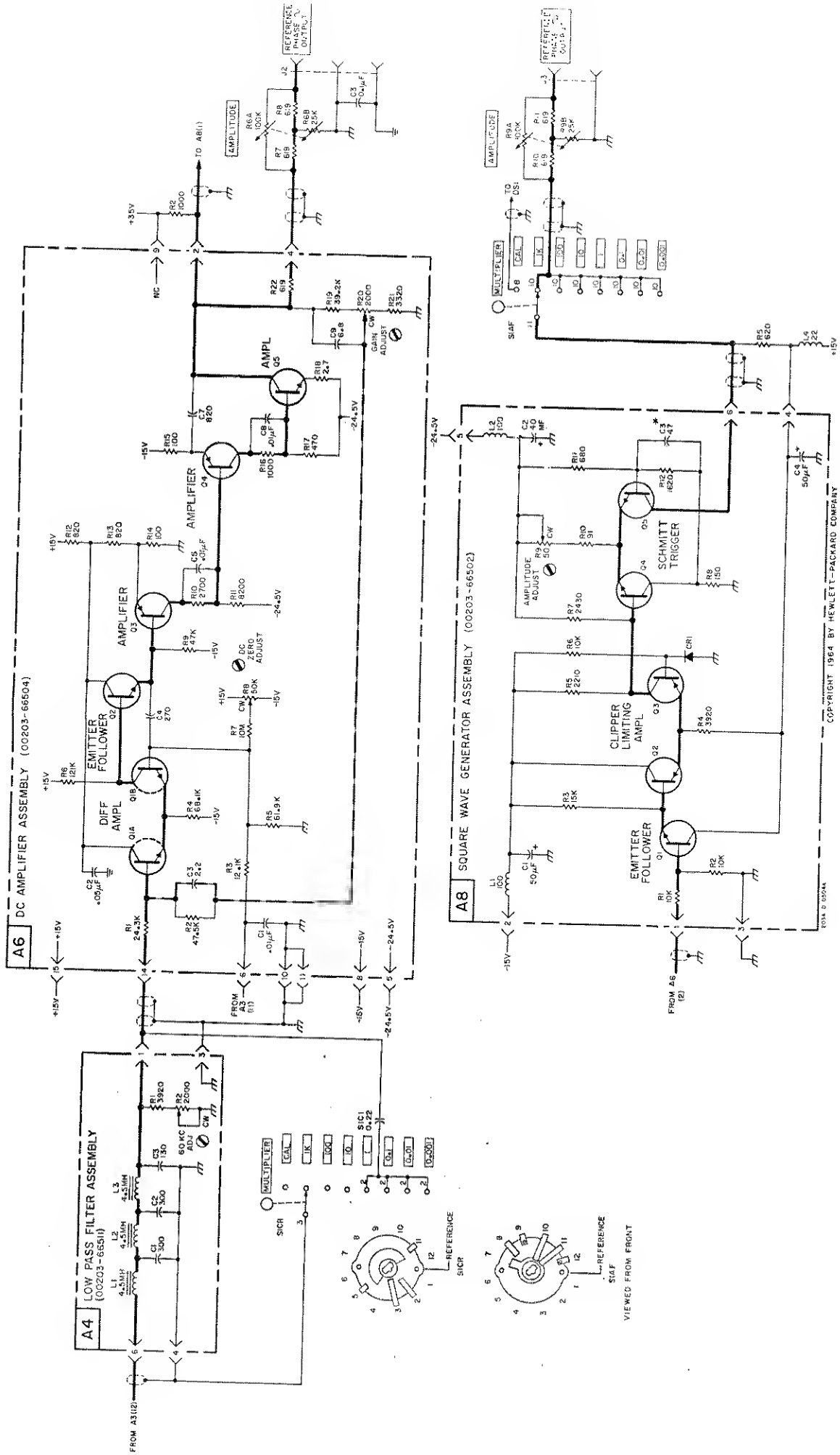

Figure 5-18. Low Pass Filter Assy A4, DC Amp Assy A6, and Square Wave Gen Assy A8--Schematic

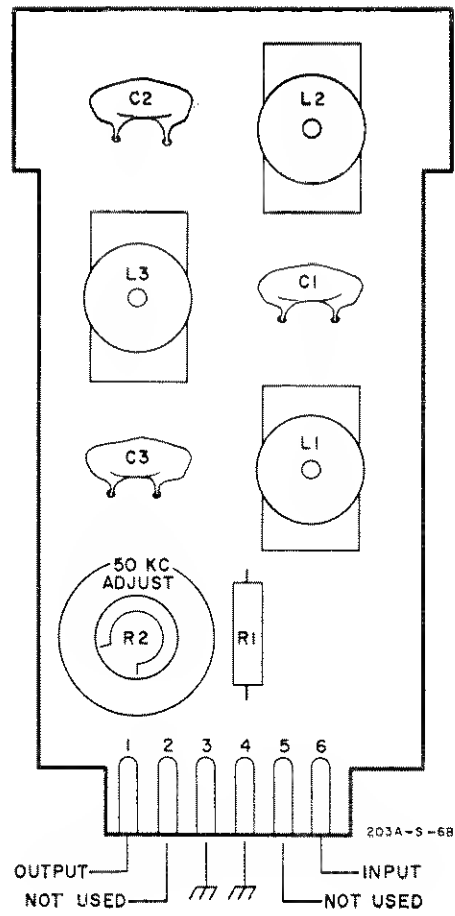

Figure 5-19a. Low Pass Filter Assy A4 and A5  
Component Location

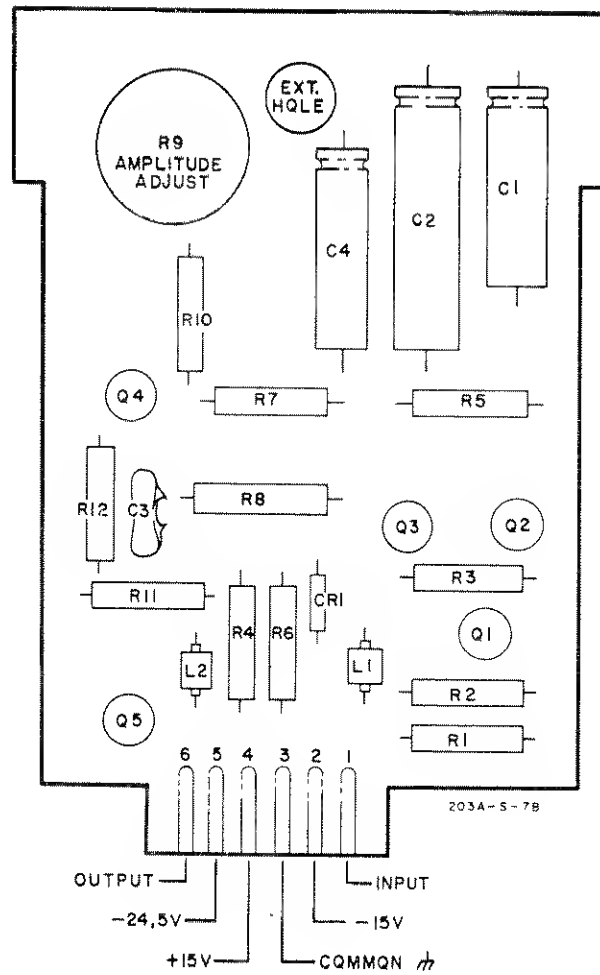
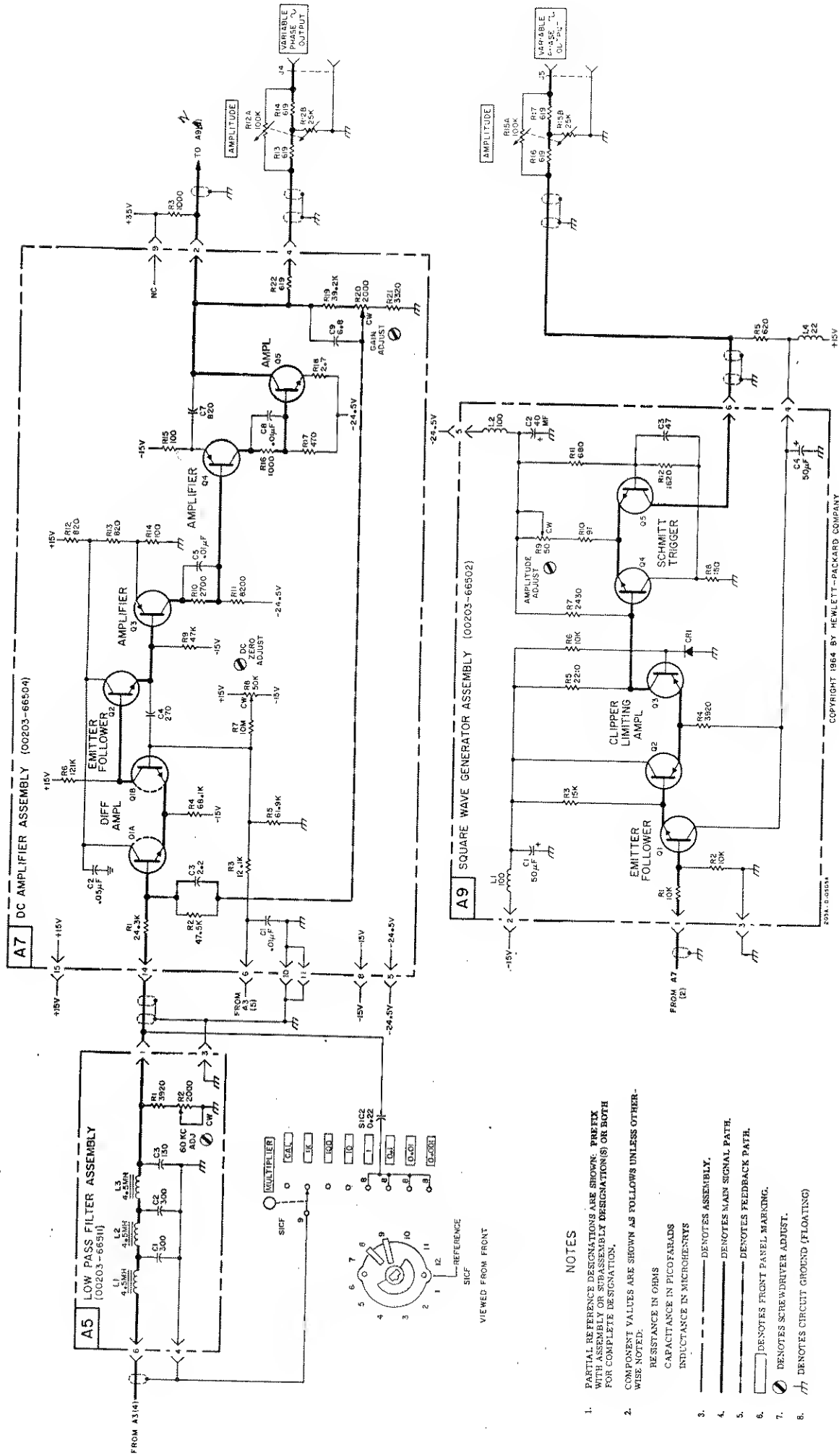

Figure 5-19b. Square Wave Gen Assy A8 and A9  
Component Location



- NOTES**
- PARTIAL REFERENCE DESIGNATIONS ARE SHOWN: PREFIX WITH ASSEMBLY DESIGNATION AND ASSEMBLY DESIGNATION(S) OR BOTH FOR COMPLETE DESIGNATION.
  - COMPONENT VALUES ARE SHOWN AS FOLLOWS UNLESS OTHERWISE NOTED:  
 RESISTANCE IN OHMS  
 CAPACITANCE IN PICOFARADS  
 INDUCTANCE IN MICROHENRYS
  - DENOTES ASSEMBLY.
  - DENOTES MAIN SIGNAL PATH.
  - DENOTES FEEDBACK PATH.
  - DENOTES FRONT PANEL MARKING.
  - ⊖ DENOTES SCREWDRIVER ADJUST.
  - ⊕ DENOTES CIRCUIT GROUND (FLOATING).

Figure 5-20. Low Pass Filter Assy A5, DC Amp Assy A7, and Square Wave Ge...

### NOTES

1. PARTIAL REFERENCE DESIGNATIONS ARE SHOWN: PREFIX WITH ASSEMBLY OR SUBASSEMBLY DESIGNATION(S) OR BOTH FOR COMPLETE DESIGNATION.
2. COMPONENT VALUES ARE SHOWN AS FOLLOWS UNLESS OTHERWISE NOTED:  
 RESISTANCE IN OHMS  
 CAPACITANCE IN PICOFARADS  
 INDUCTANCE IN MICROHENRYS
3.  DENOTES ASSEMBLY.
4.  DENOTES MAIN SIGNAL PATH.
5. DENOTES SCREWDRIVER ADJUST.
6. DENOTES CIRCUIT GROUND (FLOATING).

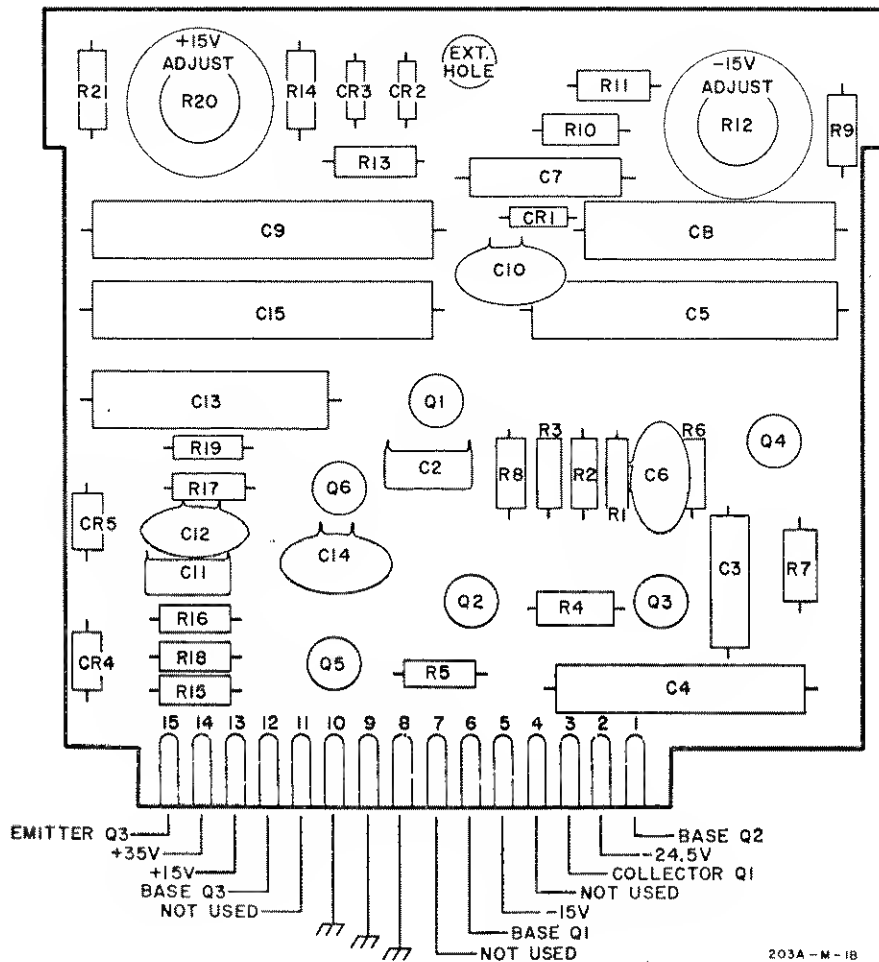

203A-M-18

Figure 5-21. Power Supply Assy A22--Component Location

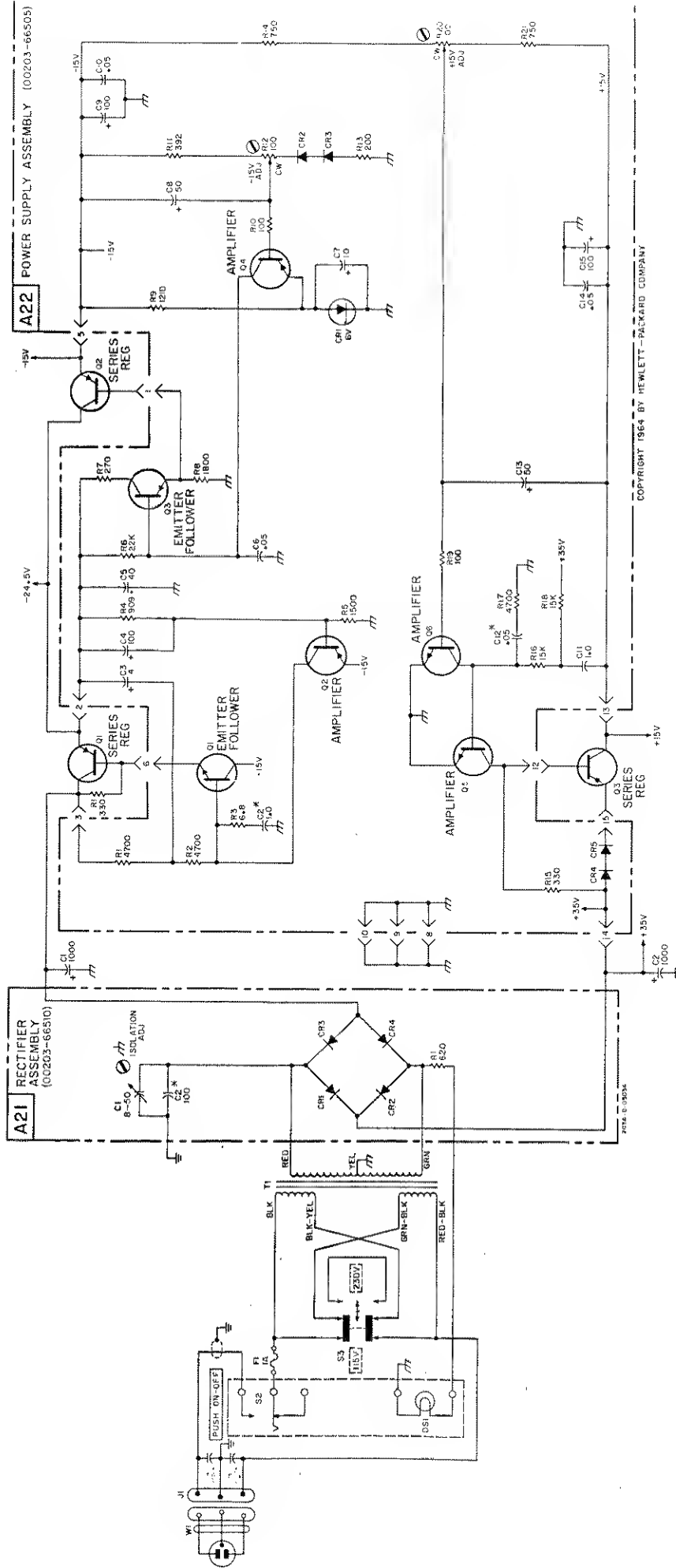

Figure 5-22. Power Supply Assy A22 and Rectifier Assy A21--Schematic



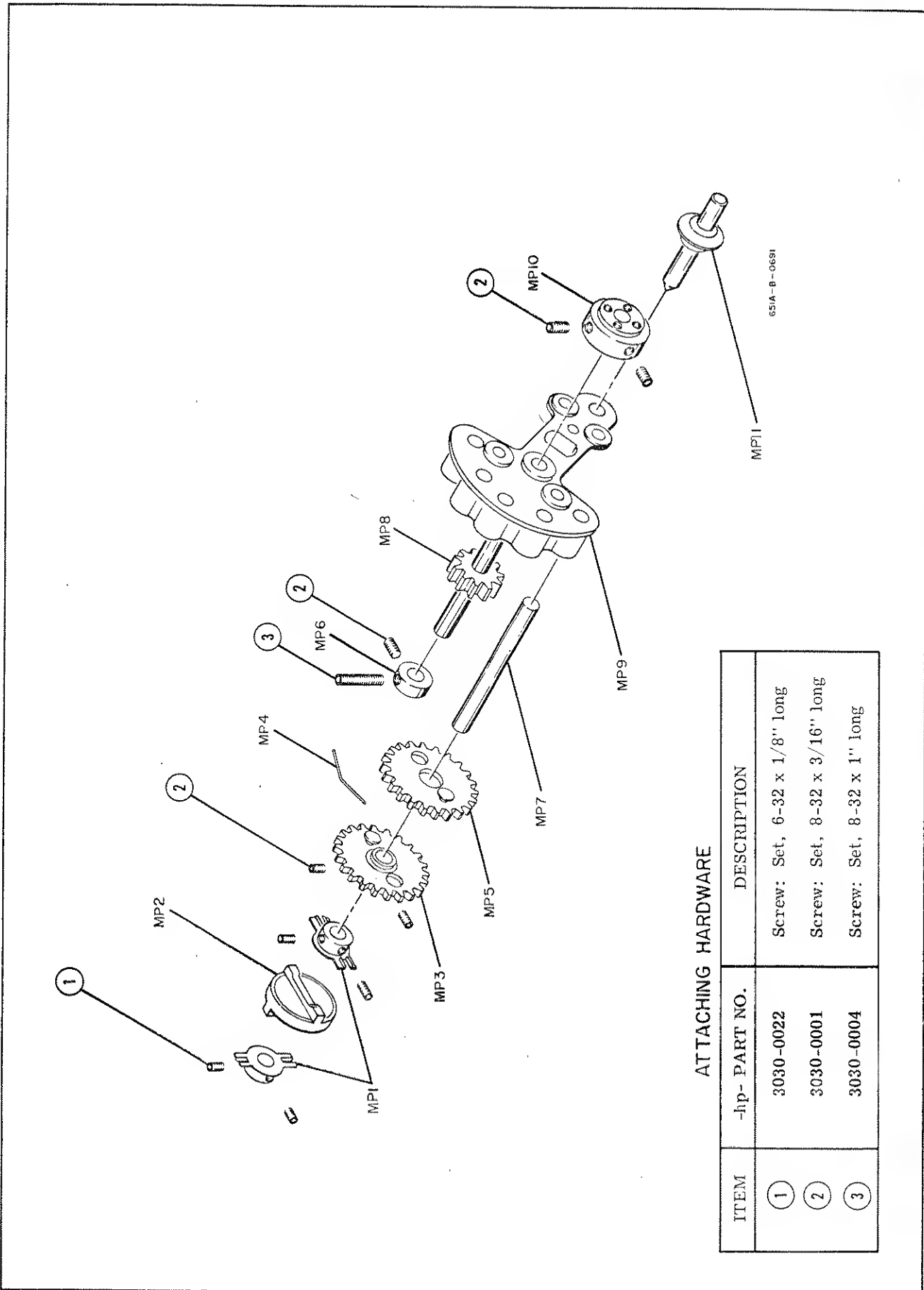

Figure 5-23. Frequency Tuning Assembly (Mechanical Parts)

## SECTION VI REPLACEABLE PARTS

### 6-1 INTRODUCTION.

6-2. This section contains information for ordering replacement parts. Table 6-1 lists parts in alphanumeric order of their reference designators and indicates the description, -hp- part number of each part, together with any applicable notes, and provides the follows:

- a. Total quantity used in the instrument (TQ column).
- b. Description of the part. (See list of abbreviations below.)
- c. Typical manufacturer of the part in a five-digit code. (See Appendix A for list of manufacturers.)
- d. Manufacturer's part number.

6-3. Miscellaneous parts are listed at the end of Table 6-1.

### 6-4. ORDERING INFORMATION.

6-5. To obtain replacement parts, address order or inquiry to your local Hewlett-Packard Field Office. (See Appendix B for list of office locations.) Identify parts by their Hewlett-Packard part numbers.

### 6-6. NON-LISTED PARTS.

6-7. To obtain a part that is not listed, include:

- a. Instrument model number.
- b. Instrument serial number.
- c. Description of the part.
- d. Function and location of the part.

DESIGNATORS			
A = assembly B = motor BT = battery C = capacitor CR = diode DL = delay line DS = lamp E = misc electronic part	F = fuse FL = filter HR = heater J = jack K = relay L = inductor M = meter MP = mechanical part	P = plug Q = transistor QCR = transistor-diode R = resistor RT = thermistor S = switch T = transformer TC = thermocouple	V = vacuum tube, neon bulb, photocell etc. W = cable X = socket XDS = lampholder XF = fuseholder Z = network
ABBREVIATIONS			
Ag = silver Al = aluminum amp = ampere (s) Au = gold C = capacitor cer = ceramic coef = coefficient com = common comp = composition conn = connection cps = cycles per second dep = deposited DPDT = double-pole double-throw DPST = double-pole single-throw elect = electrolytic encap = encapsulated f = farad (s) FET = field effect transistor fxd = fixed GaAs = gallium arsenide Gc = gigacycle (s) = 10 <sup>+9</sup> gd = guard (ed) Ge = germanium grd = ground (ed) h = henry (ies) Hg = mercury	ID = inside diameter impg = impregnated incd = incandescent ins = insulation (ed) K = kilohm (s) = 10 <sup>+3</sup> Kc = kilocycle (s) = 10 <sup>+3</sup> L = inductor lin = linear taper log = logarithmic taper m = mill = 10 <sup>-3</sup> ma = milliampere (s) = 10 <sup>-3</sup> Mc = megacycle (s) = 10 <sup>+6</sup> meg = megohm (s) = 10 <sup>+6</sup> met film = metal film mfr = manufacturer mtg = mounting μ = micro = 10 <sup>-6</sup> my = Mylar ® na = nanoampere (s) = 10 <sup>-9</sup> NC = normally closed Ne = neon NO = normally open NPO = negative positive zero (zero temperature coefficient)	ns = nanosecond (s) = 10 <sup>-9</sup> nsr = not separately replaceable obd = order by description OD = outside diameter p = peak pc = printed circuit pf = picofarad (s) = 10 <sup>-12</sup> piv = peak inverse voltage p/o = part of pos = position (s) poly = polystyrene pot = potentiometer p-p = peak-to-peak prec = precision (temperature coefficient, long term stability, and/or tolerance) R = resistor Rh = rhodium rms = root-mean-square rot = rotary Se = selenium sect = section (s) Si = silicon sl = slide	SPDT = single-pole double-throw SPST = single-pole single-throw Ta = tantalum TiO <sub>2</sub> = titanium dioxide tog = toggle tol = tolerance trim = trimmer TSTR = transistor v = volt (s) vacw = alternating current working volt (s) var = variable vdcw = direct current working volt (s) w = watt (s) w/ = with w/v = reverse working voltage w/o = without ww = wirewound * = optimum value selected at factory, average value shown (part may be omitted) ** = no standard type number assigned (selected or special type)
® Dupont de Nemours			

List of Reference Designators and Abbreviations

Table 6-1. Reference Designation Index

REFERENCE DESIGNATION	☉ STOCK NO.	DESCRIPTION	NOTE
A1	00203-66503	Board ass'y, 5 mcps, includes: C1 thru C13                      R1 thru R9 L1, L2                              T1, T2 Q1 thru Q4                        Y1	
A1C1	0140-0207	C: fxd, dipped mica, 330 pf ±5%	
A1C2	0150-0096	C: fxd, cer, 0.05 μfd +80% -20%, 100 vdcw	
A1C3	0140-J204	C: fxd, dipped mica, 47 pf ±5%	
A1C4	0140-0208	C: fxd, dipped mica, 680 pf ±5%	
A1C5	0150-0096	C: fxd, cer, 0.05 μfd +80% -20%, 100 vdcw	
A1C6	0140-0201	C: fxd, dipped mica, 12 pf ±5%	
A1C7	0140-0176	C: fxd, dipped mica, 100 pf ±2%	
A1C8	0140-0217	C: fxd, dipped mica, 140 pf ±2%	
A1C9	0140-0151	C: fxd, dipped mica, 820 pf ±2%	
A1C10	0150-0096	C: fxd, cer, 0.05 μfd +80% -20%, 100 vdcw	
A1C11	0140-0157	C: fxd, dipped mica, 1857 pf ±1%	
A1C12	0140-0178	C: fxd, dipped mica, 560 pf ±2%	
A1C13	0160-0147	C: fxd, dipped mica, 2500 pf ±2%	
A1L1	9140-0029	Coil, R. F., choke, universal wound, unshielded, 100 μh, 2.6 ohms	
A1L2	00203-86009	Coil, var	
A1Q1 thru A1Q4	1854-0005	Transistor, EIA type 2N708, NPN silicon planar	
A1R1, A1R2	0687-1521	R: fxd, comp, 1500 ohms ±10%, 1/2 W	
A1R3	0687-2221	R: fxd, comp, 2200 ohms ±10%, 1/2 W	
A1R4	0687-5621	R: fxd, comp, 5600 ohms ±10%, 1/2 W	
A1R5	0687-1231	R: fxd, comp, 12 K ohms ±10%, 1/2 W	
A1R6	0687-1031	R: fxd, comp, 10 K ohms ±10%, 1/2 W	
A1R7	0687-1521	R: fxd, comp, 1500 ohms ±10%, 1/2 W	
A1R8	0687-4721	R: fxd, comp, 4700 ohms ±10%, 1/2 W	
A1R9	0687-1031	R: fxd, comp, 10 K ohms ±10%, 1/2 W	
A1T1	00203-84204	Transformer, tuned	
A1T2	00203-84203	Transformer, tuned	
A1Y1	0410-0009	Crystal unit, quartz, 5 mc, 2 pins on bottom	
A2	00203-66506	Board ass'y, R. F. Amplifier, includes: C1 thru C31                      Q1 thru Q9 CR1 thru CR4                    R1 thru R15 L1 thru L7                        T1, T2	
A2C1	0131-0003	C: var, mica, single sect, 170 - 780 pf, 175 vdcw	
A2C2*	0160-0217	C: fxd, dipped mica, 2300 pf ±1%	
A2C3	0160-0174	C: fxd, cer, 0.47 μf +80% -20%, 25 vdcw	
A2C4	0150-0096	C: fxd, cer, 0.05 μfd +80% -20%, 100 vdcw	
A2C5	0160-0174	C: fxd, cer, 0.47 μf +80% -20%, 25 vdcw	
A2C6	0150-0012	C: fxd, cer, 0.01 μf ±20%, 1000 vdcw	
A2C7*	0160-0376	C: fxd, dipped mica, 68 pf ±5%	
A2C8	0160-0174	C: fxd, cer, 0.47 μf +80% -20%, 25 vdcw	
A2C9	0150-0096	C: fxd, cer, 0.05 μfd +80% -20%, 100 vdcw	
A2C10	0150-0012	C: fxd, cer, 0.01 μf ±20%, 1000 vdcw	
A2C11*	0150-0145	C: fxd, cer, 22 pf ±10%, 500 vdcw	
A2C12	0150-0069	C: fxd, cer, 0.001 μf +100% -20%, 500 vdcw	
A2C13	0140-0154	C: fxd, dipped mica, 1300 pf ±5%	
A2C14	0160-3132	C: fxd, cer, 200 pf ±10%, 500 vdcw	
A2C15	0150-0096	C: fxd, cer, 0.05 μfd +80% -20%, 100 vdcw	

\* Average value shown, optimum value selected at factory  
# See introduction to this section

Table 6-1. Reference Designation Index (Cont'd)

REFERENCE DESIGNATION	Ⓢ STOCK NO.	DESCRIPTION	NOTE
A2C16	0160-0127	C: fxd, cer, 1.0 $\mu$ f $\pm$ 20%, 25 vdcw	
A2C17, A2C18	0140-0152	C: fxd, mica, 1000 pf $\pm$ 5%, 300 vdcw	
A2C19	0140-0161	C: fxd, dipped mica, 3932 pf $\pm$ 1%	
A2C20	0150-0096	C: fxd, cer, 0.05 $\mu$ fd +80% -20%, 100 vdcw	
A2C21	0140-0178	C: fxd, dipped mica, 560 pf $\pm$ 2%	
A2C22	0160-0174	C: fxd, cer, 0.47 $\mu$ f +80% -20%, 25 vdcw	
A2C23	0150-0012	C: fxd, cer, 0.01 $\mu$ f $\pm$ 20%, 1000 vdcw	
A2C24	0140-0154	C: fxd, dipped mica, 1300 pf $\pm$ 5%	
A2C25	0160-3132	C: fxd, cer, 200 pf $\pm$ 10%, 500 vdcw	
A2C26	0150-0093	C: fxd, cer, 0.05 $\mu$ fd +80% -20%, 100 vdcw	
A2C27	0160-0127	C: fxd, cer, 1.0 $\mu$ f $\pm$ 20%, 25 vdcw	
A2C28, A2C29	0140-0152	C: fxd, mica, 1000 pf $\pm$ 5%, 300 vdcw	
A2C30	0140-0161	C: fxd, dipped mica, 3932 pf $\pm$ 1%	
A2C31	0180-0059	C: fxd, elect, 10 $\mu$ f -10% +100%, 25 vdcw	
A2CR1 thru A2CR4	1901-0040	Diode, silicon, 30 MA at +1 v, 30 PIV, 2 pf, 2 ns	
A2L1	9140-0037	Coil, radio freq. 5 mh induct, universal wound	
A2L2		Not assigned	
A2L3	00203-86003	Coil, var	
A2L4, A2L5	9140-0037	Coil, radio freq. 5 mh induct, universal wound	
A2L6		Not assigned	
A2L7	00203-86010	Coil, var	
A2Q1 thru A2Q4	1853-0016	Transistor, 2N3638 PNP silicon	
A2Q5	1854-0033	Transistor, EIA type 2N3391, NPN silicon	
A2Q6 thru A2Q8	1853-0016	Transistor, 2N3638 PNP silicon	
A2Q9	1854-0033	Transistor, EIA type 2N3391, NPN silicon	
A2R1	0687-1021	R: fxd, comp, 1000 ohms $\pm$ 10%, 1/2 W	
A2R2	0687-6811	R: fxd, comp, 680 ohms $\pm$ 10%, 1/2 W	
A2R3	0757-0736	R: fxd, met flm, 1.5 K ohms $\pm$ 1%, 1/4 W	
A2R4	0757-0715	R: fxd, met flm, 150 ohms $\pm$ 1%, 1/4 W	
A2R5	0687-4721	R: fxd, comp, 4700 ohms $\pm$ 10%, 1/2 W	
A2R6	0757-1032	R: fxd, met flm, 100 ohms $\pm$ 0.5%, 1/4 W	
A2R7	0687-6811	R: fxd, comp, 680 ohms $\pm$ 10%, 1/2 W	
A2R8	0757-0736	R: fxd, met flm, 1.5 K ohms $\pm$ 1%, 1/4 W	
A2R9	0757-0715	R: fxd, met flm, 150 ohms $\pm$ 1%, 1/4 W	
A2R10	0687-4721	R: fxd, comp, 4700 ohms $\pm$ 10%, 1/2 W	
A2R11	0687-4731	R: fxd, comp, 47 K ohms $\pm$ 10%, 1/2 W	
A2R12	0687-3921	R: fxd, comp, 3900 ohms $\pm$ 10%, 1/2 W	
A2R13	0687-4701	R: fxd, comp, 47 ohms $\pm$ 10%, 1/2 W	
A2R14	0687-1031	R: fxd, comp, 10 K ohms $\pm$ 10%, 1/2 W	
A2R15	0687-4731	R: fxd, comp, 47 K ohms $\pm$ 10%, 1/2 W	
A2R16, A2R17	0687-5601	R: fxd, comp, 56 ohms	
A2T1	00203-84205	Transformer, tuned	
A2T2	00203-84206	Transformer, tuned	

# See introduction to this section

Table 6-1. Reference Designation Index (Cont'd)

REFERENCE DESIGNATION	Ⓢ STOCK NO.	DESCRIPTION	NOTE
A3	00203-66507	Board, ass'y, modulator, includes: C1 thru C20                    R1 thru R39 L1 thru L6                    T1 thru T4 Q1 thru Q13	
A3C1	0160-0174	C: fxd, cer, 0.47 $\mu$ f +80% -20%, 25 vdcw	
A3C2	0150-0047	C: fxd, TiO <sub>2</sub> , 6.8 pf $\pm$ 10%, 500 vdcw	
A3C3	0160-0174	C: fxd, cer, 0.47 $\mu$ f +80% -20%, 25 vdcw	
A3C4, A3C5	0150-0093	C: fxd, cer, 0.01 $\mu$ f +80% -20%, 100 vdcw	
A3C6	0160-0174	C: fxd, cer, 0.47 $\mu$ f +80% -20%, 25 vdcw	
A3C7	0140-0153	C: fxd, mica, 1269 pf $\pm$ 1%, 300 vdcw	
A3C8	0150-0096	C: fxd, cer, 0.05 $\mu$ fd +80% -20%, 100 vdcw	
A3C9	0160-0174	C: fxd, cer, 0.47 $\mu$ f +80% -20%, 25 vdcw	
A3C10, A3C11	0150-0096	C: fxd, cer, 0.05 $\mu$ fd +80% -20%, 100 vdcw	
A3C12	0150-0071	C: fxd, cer, 400 pf $\pm$ 5%, 500 vdcw	
A3C13	0180-0059	C: fxd, elect, 10 $\mu$ f -10% +100%, 25 vdcw	
A3C14, A3C15	0140-0195	C: fxd, dipped mica, 150 pf $\pm$ 5%	
A3C16, A3C17	0150-0096	C: fxd, cer, 0.05 $\mu$ fd +80% -20%, 100 vdcw	
A3C18	0150-0071	C: fxd, cer, 400 pf $\pm$ 5%, 500 vdcw	
A3C19, A3C20	0140-0195	C: fxd, dipped mica, 130 pf $\pm$ 5%	
A3L1 thru A3L3	9140-0137	Coil, fixed R. F., 1000 $\mu$ h $\pm$ 5%, dc current rating 135 ma	
A3L4	9140-0029	Coil, R. F. choke, universal wound, unshielded, 100 $\mu$ h, 2.6 ohms	
A3L5	9140-0031	Coil, R. F., 75 $\mu$ h	
A3L6	9140-0137	Coil, fxd, R. F. 1000 $\mu$ h $\pm$ 5%, dc current rating 135 ma	
A3Q1	1854-0033	Transistor, EIA type 2N3391, NPN silicon	
A3Q2, A3Q3	1854-0005	Transistor, EIA type 2N708, NPN silicon planar	
A3Q4	1854-0039	Transistor, EIA type 2N3053, NPN silicon	
A3Q5 thru A3Q8	1854-0033	Transistor, EIA type 2N3391, NPN silicon	
A3Q9	1854-0039	Transistor, EIA type 2N3053, NPN silicon	
A3Q10 thru A3Q13	1854-0033	Transistor, EIA type 2N3391, NPN silicon	
A3R1	0687-1031	R: fxd, comp, 10K ohms $\pm$ 10%, 1/2 W	
A3R2	0687-1521	R: fxd, comp, 1500 ohms $\pm$ 10%, 1/2 W	
A3R3	0687-4711	R: fxd, comp, 470 ohms $\pm$ 10%, 1/2 W	
A3R4	0687-2221	R: fxd, comp, 2200 ohms $\pm$ 10%, 1/2 W	
A3R5*	0683-4715	R: fxd, comp, 470 ohms, $\pm$ 5%, 1/4 W	
A3R6	0687-4721	R: fxd, comp, 4700 ohms $\pm$ 10%, 1/2 W	
A3R7	0687-4711	R: fxd, comp, 470 ohms $\pm$ 10%, 1/2 W	
A3R8	0687-2221	R: fxd, comp, 2200 ohms $\pm$ 10%, 1/2 W	
A3R9, A3R10	0687-4711	R: fxd, comp, 470 ohms $\pm$ 10%, 1/2 W	
A3R11	0687-1521	R: fxd, comp, 1500 ohms $\pm$ 10%, 1/2 W	
A3R12	0757-0743	R: fxd, met flm, 3.32K ohms $\pm$ 1%, 1/4 W	
A3R13	2100-0282	R: var, lin, ww, 2000 ohms $\pm$ 20%, 1-1/2 W	
A3R14	0757-0743	R: fxd, met flm, 1.21K ohms $\pm$ 1%, 1/4 W	
A3R15	0757-0745	R: fxd, met flm, 4.32K ohms $\pm$ 1%, 1/4 W	
A3R16	0757-0339	R: fxd, met flm, 3.01K ohms $\pm$ 1%, 1/4 W	

\*Average value shown, optimum value selected at factory

# See introduction to this section

Table 6-1. Reference Designation Index (Cont'd)

REFERENCE DESIGNATION	Ⓢ STOCK NO.	DESCRIPTION	NOTE
A3R17	2100-0909	R: var, comp, lin, 100 ohms $\pm 30\%$ , 1/4 W	
A3R18	0757-0339	R: fxd, met flm, 3.01K ohms $\pm 1\%$ , 1/4 W	
A3R19	0757-0761	R: fxd, met flm, 22.1K ohms $\pm 1\%$ , 1/4 W	
A3R20	2100-0908	R: var, comp, lin, 2K $\pm 30\%$ , 1/4 W	
A3R21	0757-0761	R: fxd, met flm, 22.1K ohms $\pm 1\%$ , 1/4 W	
A3R22	0757-1040	R: fxd, met flm, 50 ohms $\pm 1\%$ , 1/4 W	
A3R23	0757-0339	R: fxd, met flm, 3.01K ohms $\pm 1\%$ , 1/4 W	
A3R24	0757-1040	R: fxd, met flm, 50 ohms $\pm 1\%$ , 1/4 W	
A3R25	0757-0339	R: fxd, met flm, 3.01K ohms $\pm 1\%$ , 1/4 W	
A3R26, A3R27	0687-4711	R: fxd, comp, 470 ohms $\pm 10\%$ , 1/2 W	
A3R28	0687-1521	R: fxd, comp, 1500 ohms $\pm 10\%$ , 1/2 W	
A3R29	0757-0745	R: fxd, met flm, 4.32K ohms $\pm 1\%$ , 1/4 W	
A3R30	0757-0339	R: fxd, met flm, 3.01K ohms $\pm 1\%$ , 1/4 W	
A3R31	2100-0909	R: var, comp, lin, 100 ohms $\pm 30\%$ , 1/4 W	
A3R32	0757-0339	R: fxd, met flm, 3.01K ohms $\pm 1\%$ , 1/4 W	
A3R33	0757-0761	R: fxd, met flm, 22.1K ohms $\pm 1\%$ , 1/4 W	
A3R34	2100-0908	R: var, comp, lin, 2K $\pm 30\%$ , 1/4 W	
A3R35	0757-0761	R: fxd, met flm, 22.1K ohms $\pm 1\%$ , 1/4 W	
A3R36	0757-1040	R: fxd, met flm, 50 ohms $\pm 1\%$ , 1/4 W	
A3R37	0757-0339	R: fxd, met flm, 3.01K ohms $\pm 1\%$ , 1/4 W	
A3R38	0757-1040	R: fxd, met flm, 50 ohms $\pm 1\%$ , 1/4 W	
A3R39	0757-0339	R: fxd, met flm, 3.01K ohms $\pm 1\%$ , 1/4 W	
A3T1, A3T2	00203-86005	Transformer, driver	
A3T3, A3T4	00203-86004	Transformer, driver	
A4	00203-66511	Board ass'y, filter, includes: C1 thru C3                      R1, R2 L1 thru L3	
A4C1, A4C2	0140-0225	C: fxd, dipped mica, 300 pf $\pm 1\%$ , 300 vdcw	
A4C3	0140-0195	C: fxd, dipped mica, 130 pf $\pm 5\%$ , 300 vdcw	
A4L1 thru A4L3	00203-86006	Coil, fxd, 4.5 mh	
A4R1	0757-0744	R: fxd, met flm, 3.92K ohms $\pm 1\%$ , 1/4 W	
A4R2	2100-0282	R: var, lin, ww, 2000 ohms $\pm 20\%$ , 1-1/2 W	
A5	00203-66511	All components same as A4	
A6	00203-66504	Board ass'y, dc amplifier, includes: C1 thru C9                      R1 thru R22 Q1 thru Q5	
A6C1	0150-0012	C: fxd, cer, 0.01 $\mu$ f $\pm 20\%$ , 1000 vdcw	
A6C2	0150-0096	C: fxd, cer, 0.05 $\mu$ fd $\pm 80\%$ -20%, 100 vdcw	
A6C3	0150-0015	C: fxd, TiO <sub>2</sub> , 2.2 pf $\pm 10\%$ , 500 vdcw	
A6C4	0140-0206	C: fxd, dipped mica, 270 pf $\pm 5\%$	
A6C5	0150-0012	C: fxd, cer, 0.01 $\mu$ f $\pm 20\%$ , 1000 vdcw	
A6C6		Not assigned	
A6C7	0140-0151	C: fxd, dipped mica, 820 pf $\pm 2\%$ , 300 vdcw	
A6C8	0150-0012	C: fxd, cer, 0.01 $\mu$ f $\pm 20\%$ , 1000 vdcw	
A6C9	0150-0047	C: fxd, TiO <sub>2</sub> , 6.8 pf $\pm 10\%$ , 500 vdcw	

*Cap On Subst'd By  
Circuit 72-17*

# See introduction to this section

Table 6-1. Reference Designation Index (Cont'd)

REFERENCE DESIGNATION	Ⓢ STOCK NO.	DESCRIPTION	NOTE
A6Q1A, B	1854-0014	Transistor, silicon, dual NPN silicon, special	
A6Q2	1854-0033	Transistor, EIA type 2N3391, NPN silicon	
A6Q3, A6Q4	1853-0008	Transistor, EIA type 2N3250, PNP silicon	
A6Q5	1854-0039	Transistor, EIA type, 2N3053, NPN silicon	
	1205-0033	Heat sink, semiconductor (A6Q5)	
A6R1	0757-0762	R: fxd, met flm, 24.3K ohms ±1%, 1/4 W	
A6R2	0757-0768	R: fxd, met flm, 47.5K ohms ±1%, 1/4 W	
A6R3	0757-0755	R: fxd, met flm, 12.1K ohms ±1%, 1/4 W	
A6R4	0757-0772	R: fxd, met flm, 88.1K ohms ±1%, 1/4 W	
A6R5	0757-0771	R: fxd, met flm, 81.9K ohms ±1%, 1/4 W	
A6R6	0757-0777	R: fxd, met flm, 121K ohms ±1%, 1/4 W	
A6R7	0687-1061	R: fxd, comp, 10M ohms ±10%, 1/2 W	
A6R8	2100-0094	R: var, lin, comp, 50K ohms, 30%, 1/5 W	
A6R9	0687-4731	R: fxd, comp, 46K ohms ±10%, 1/2 W	
A6R10	0687-2721	R: fxd, comp, 2700 ohms ±10%, 1/2 W	
A6R11	0687-8221	R: fxd, comp, 8200 ohms ±10%, 1/2 W	
A6R12, A6R13	0687-8211	R: fxd, comp, 820 ohms ±10%, 1/2 W	
A6R14, A6R15	0687-1011	R: fxd, comp, 100 ohms ±10%, 1/2 W	
A6R16	0687-1021	R: fxd, comp, 1000 ohms ±10%, 1/2 W	
A6R17	0687-4711	R: fxd, comp, 470 ohms ±10%, 1/2 W	
A6R18	0699-0001	R: fxd, comp, 2.7 ohms ±10%, 1/2 W	
A6R19	0757-0766	R: fxd, met flm, 39.2K ohms ±1%, 1/4 W	
A6R20	2100-0282	R: var, lin, ww, 2000 ohms ±20%, 1-1/2 W	
A6R21	0757-0743	R: fxd, met flm, 3.32K ohms ±1%, 1/4 W	
A6R22	0757-0728	R: fxd, met flm, 619 ohms ±1%, 1/4 W	
A7	00203-66504	All components same as A6	
A8	00203-66502	Board ass'y, square wave, includes: C1 thru C4            Q1 thru Q5 CR1                    R1 thru R12 L1, L2	
A8C1	0180-0105	C: fxd, Al elect, 50 μf -10% +100%, 25 vdcw	
A8C2	0180-0050	C: fxd, Al elect, 40 μf -15% +100%, 50 vdcw	
A8C3*	0140-0039	C: fxd, dipped mica, 47 pf ±5%, 500 vacw	
A8C4	0180-0105	C: fxd, Al elect, 50 μf -10% +100%, 25 vdcw	
A8CR1	1901-0025	Diode, silicon, 50 MA at +1 v, 100 PIV, 12 pf	
A8L1, A8L2	9140-0029	Coil, R. F. choke, universal wound, unshielded, 100 μh, 2.6 ohms	
A8Q1	1854-0033	Transistor, EIA type 2N3391, NPN silicon	
A8Q2, A8Q3	1850-0040	Transistor, PNP germanium	
A8Q4, A8Q5	1854-0039	Transistor, EIA type 2N3053, NPN silicon	
A8R1, A8R2	0687-1031	R: fxd, comp, 10K ohms ±10%, 1/2 W	
A8R3	0687-1531	R: fxd, comp, 15K ohms ±10%, 1/2 W	
A8R4	0757-0744	R: fxd, met flm, 3.92K ohms ±1%, 1/4 W	
A8R5	0757-0740	R: fxd, met flm, 2.21K ohms ±1%, 1/4 W	
A8R6	0687-1031	R: fxd, comp, 10K ohms ±10%, 1/2 W	
A8R7	0757-0741	R: fxd, met flm, 2.43K ohms ±1%, 1/4 W	
A8R8	0757-1050	R: fxd, met flm, 150 ohms ±1%, 1/2 W	

\*Average value shown, optimum value selected at factory

# See introduction to this section

Table 6-1. Reference Designation Index (Cont'd)

REFERENCE DESIGNATION	Ⓢ STOCK NO.	DESCRIPTION	NOTE
A8R9	2100-0206	R: var, lin, ww, 50 ohms ±10%, 1 W	
A8R10	0758-0041	R: fxd, met flm, 91 ohms ±5%, 1/2 W	
A8R11	0757-1027	R: fxd, met flm, 680 ohms ±1%, 1/4 W	
A8R12	0757-0737	R: fxd, met flm, 1.62K ohms ±1%, 1/4 W	
A9	00203-66502	All components same as A8	
A10	00203-68508	Board ass'y, V. F. O., includes: C1 thru C12            Q1 thru Q3 CR1                      R1 thru R10 L1, L2	
A10C1	0140-0156	C: fxd, dipped mica, 1500 pf ±2%, 300 vdcw	
A10C2	0140-0182	C: fxd, dipped mica, 5000 pf ±2%, 300 vdcw	
A10C3*		Not assigned	
A10C4	0150-0096	C: fxd, cer, 0.05 μfd +80% -20%, 100 vdcw	
A10C5	0140-0220	C: fxd, dipped mica, 200 pf ±1%, 300 vdcw	
A10C6	0150-0096	C: fxd, cer, 0.05 μfd +80% -20%, 100 vdcw	
A10C7	0140-0178	C: fxd, dipped mica, 560 pf ±2%, 300 vdcw	
A10C8	0150-0071	C: fxd, cer, 400 pf ±5%, 500 vdcw	
A10C9	0150-0096	C: fxd, cer, 0.05 μfd +80% -20%, 100 vdcw	
A10C10	0140-0153	C: fxd, mica, 1269 pf ±1%, 300 vdcw	
A10C11	0140-0170	C: fxd, dipped mica, 5600 pf ±5%, 300 vdcw	
A10C12	0140-0217	C: fxd, dipped mica, 140 pf ±2%, 300 vdcw	
A10CR1	1901-0040	Diode, silicon, 30 MA at +1 v, 30 PIV, 2 pf, 2 ns	
A10L1	9140-0041	Coil, R. F., 2.5 mh ±10%	
A10L2	9140-0029	Coil, R. F. choke, universal wound, unshielded, 100 μh, 2.6 ohms	
A10Q1	1854-0033	Transistor, EIA type 2N3391, NPN silicon	
A10Q2, A10Q3	1854-0005	Transistor, EIA type 2N708, NPN silicon planar	
A10R1	0758-0017	R: fxd, met flm, 1500 ohms ±5%, 1/2 W	
A10R2	0757-0768	R: fxd, met flm, 47.5K ohms ±1%, 1/4 W	
A10R3	0757-0774	R: fxd, met flm, 82.5K ohms ±1%, 1/4 W	
A10R4	0757-0738	R: fxd, met flm, 1.82K ohms ±1%, 1/4 W	
A10R5	0757-0757	R: fxd, met flm, 15K ohms ±1%, 1/4 W	
A10R6	0757-0759	R: fxd, met flm, 18.2K ohms ±1%, 1/4 W	
A10R7	0686-6225	R: fxd, comp, 6200 ohms ±5%, 1/2 W	
A10R8	0757-0740	R: fxd, met flm, 2.21K ohms ±1%, 1/4 W	
A10R9	0687-1031	R: fxd, comp, 10K ohms ±10%, 1/2 W	
A10R10	0687-1041	Not assigned.	
A11	00203-66501	Board ass'y, decade module, includes: C1 thru C17            Q1 thru Q3 CR1 thru CR3        R1 thru R11 L1, L2                      T1, T2	
A11C1, A11C2	0150-0096	C: fxd, cer, 0.05 μfd +80% -20%, 100 vdcw	
A11C3	0140-0145	C: fxd, dipped mica, 22 pf ±5%	
A11C4, A11C5	0140-0198	C: fxd, dipped mica, 200 pf ±5%, 300 vdcw	
A11C6, A11C7	0140-0156	C: fxd, dipped mica, 1500 pf ±2%, 300 vdcw	
A11C8	0150-0093	C: fxd, 0.01 μf +80% -20%, 100 vdcw	

\*Average value shown, optimum value selected at factory

# See introduction to this section



Table 6-1. Reference Designation Index (Cont'd)

REFERENCE DESIGNATION	STOCK NO.	DESCRIPTION	NOTE
A11C9	0140-0224	C: fxd, dipped mica, 280 pf $\pm 1\%$ , 300 vdcw	
A11C10	0140-0151	C: fxd, dipped mica, 820 pf $\pm 2\%$ , 300 vdcw	
A11C11	0160-0179	C: fxd, dipped mica, 33 pf $\pm 5\%$ , 300 vdcw	
A11C12	0140-0192	C: fxd, dipped mica, 68 pf $\pm 5\%$ , 300 vdcw	
A11C13	0140-0218	C: fxd, dipped mica, 160 pf $\pm 2\%$ , 300 vdcw	
A11C14	0140-0152	C: fxd, mica, 1000 pf $\pm 5\%$ , 300 vdcw	
A11C15	0140-0154	C: fxd, dipped mica, 1300 pf $\pm 5\%$ , 500 vdcw	
A11C16	0150-0093	C: fxd, 0.01 $\mu$ f $+80\%$ $-20\%$ , 100 vdcw	
A11C17	0140-0195	C: fxd, dipped mica, 130 pf $\pm 5\%$ , 300 vdcw	
A11CR1, A11CR2	1910-0016	Diode, germanium, 100 MA at +0.85 v, 60 v working	
A11CR3	1901-0040	Diode, silicon, 30 MA at +1 v, 30 PIV, 2 pf, 2 ns	
A11L1	00203-86001	Coil, var	
A11L2	00203-86002	Coil, var	
A11Q1 thru A11Q3	1854-0005	Transistor, EIA type 2N708, NPN silicon planar	
A11R1	0687-1021	R: fxd, comp, 1000 ohms $\pm 10\%$ , 1/2 W	
A11R2 thru A11R4	0687-4721	R: fxd, comp, 4700 ohms $\pm 10\%$ , 1/2 W	
A11R5, A11R6	0757-0761	R: fxd, met flm, 22.1K ohms $\pm 1\%$ , 1/4 W	
A11R7	0687-1031	R: fxd, comp, 10K ohms $\pm 10\%$ , 1/2 W	
A11R8	0687-4721	R: fxd, comp, 4700 ohms $\pm 10\%$ , 1/2 W	
A11R9	0687-2221	R: fxd, comp, 2200 ohms $\pm 10\%$ , 1/2 W	
A11R10	0687-1031	R: fxd, comp, 10K ohms $\pm 10\%$ , 1/2 W	
A11R11	0687-1051	R: fxd, comp, 1M ohms $\pm 10\%$ , 1/2 W	
A11T1	00203-84202	Transformer, tuned	
A11T2	00203-84201	Transformer, tuned	
A12 thru A16	00203-66501	All components same as A11	
A17, A18		Optional	
A19, A20		Not assigned	
A21	00203-66510	Board ass'y, rectifier, includes: C1, C2 R1 CR1 thru CR4	
A21C1	0130-0017	C: var, cer, 8 - 50 pf	
A21C2*	0140-0054	C: fxd, cer, 100 pf $\pm 5\%$ , 500 vdcw	
A21CR1 thru A21CR4	1901-0028	Diode, silicon, rectifier, 400 PIV, 0.75 amp	
A21R1	0761-0022	R: fxd, met oxide flm, 620 ohms $\pm 5\%$ , 1 W	
A22	00203-66505	Board ass'y, power supply, includes: C1 thru C15 Q1 thru Q6 CR1 thru CR5 R1 thru R21	
A22C1		Not assigned	
A22C2*	0160-0127	C: fxd, cer, 1.0 $\mu$ f $\pm 20\%$ , 25 vdcw	

\*Average value shown, optimum value selected at factory

# See introduction to this section

Table 6-1. Reference Designation Index (Cont'd)

REFERENCE DESIGNATION	STOCK NO.	DESCRIPTION	NOTE
A22C3	0180-0114	C: fxd, Al elect, 4 $\mu$ f +100% -10%, 25 vdcw	
A22C4	0180-0039	C: fxd, elect, 100 $\mu$ f, 12 vdcw	
A22C5	0180-0050	C: fxd, Al elect, 40 $\mu$ f -15% +100%, 50 vdcw	
A22C6	0150-0096	C: fxd, cer, 0.05 $\mu$ fd, +80% -20%, 100 vdcw	
A22C7	0180-0224	C: fxd, Al elect, 10 $\mu$ f -10% +75%, 15 vdcw	
A22C8	0180-0105	C: fxd, Al elect, 50 $\mu$ f -10% +100%, 25 vdcw	
A22C9	0180-0094	C: fxd, Al elect, 100 $\mu$ f -10% +100%, 25 vdcw	
A22C10	0150-0096	C: fxd, cer, 0.05 $\mu$ fd +80% -20%, 100 vdcw	
A22C11	0160-0127	C: fxd, cer, 1.0 $\mu$ f $\pm$ 20%, 25 vdcw	
A22C12*	0150-0096	C: fxd, cer, 0.05 $\mu$ fd +80% -20%, 100 vdcw	
A22C13	0180-0105	C: fxd, Al elect, 50 $\mu$ f -10% +100%, 25 vdcw	
A22C14	0150-0096	C: fxd, cer, 0.05 $\mu$ fd +80% -20%, 100 vdcw	
A22C15	0180-0094	C: fxd, Al elect, 100 $\mu$ f -10% +100%, 25 vdcw	
A22CR	1902-0761	Diode, breakdown, EIA type 1N821, 5.9 to 6.5 v	
A22CR2,	1901-0025	Diode, silicon, 50 MA at +1 v, 100 PIV, 12 pf	
A22CR3			
A22CR4,	1901-0028	Diode, silicon, rectifier, 400 PIV, 0.75 amp	
A22CR5			
A22Q1	1854-0039	Transistor, EIA type 2N3053, NPN silicon	
A22Q2 thru	1850-0040	Transistor, PNP germanium	
A22Q4			
A22Q5	1854-0039	Transistor, EIA type 2N3053, NPN silicon	
A22Q6	1851-0017	Transistor, EIA type 2N1304, NPN germanium	
A22R1, A22R2	0687-4721	R: fxd, comp, 4700 ohms $\pm$ 10%, 1/2 W	
A22R3	0699-0002	R: fxd, comp, 6.8 ohms $\pm$ 10%, 1/2 W	
A22R4	0757-0732	R: fxd, met flm, 909 ohms $\pm$ 1%, 1/4 W	
A22R5	0757-0736	R: fxd, met flm, 1.5K ohms $\pm$ 1%, 1/4 W	
A22R6	0687-2231	R: fxd, comp, 22K ohms $\pm$ 10%, 1/2 W	
A22R7	0687-2711	R: fxd, comp, 270 ohms $\pm$ 10%, 1/2 W	
A22R8	0687-1821	R: fxd, comp, 1800 ohms $\pm$ 10%, 1/2 W	
A22R9	0757-0734	R: fxd, met flm, 1.21K ohms $\pm$ 1%, 1/4 W	
A22R10	0687-1011	R: fxd, comp, 100 ohms $\pm$ 10%, 1/2 W	
A22R11	0757-0724	R: fxd, met flm, 392 ohms $\pm$ 1%, 1/4 W	
A22R12	2100-0281	R: var, lin, ww, 100 ohms $\pm$ 20%, 1-1/2 W	
A22R13	0757-1033	R: fxd, met flm, 200 ohms $\pm$ 0.5%, 1/4 W	
A22R14	0757-0730	R: fxd, met flm, 750 ohms $\pm$ 1%, 1/4 W	
A22R15	0687-3311	R: fxd, comp, 330 ohms $\pm$ 10%, 1/2 W	
A22R16	0687-1531	R: fxd, comp, 15K ohms $\pm$ 10%, 1/2 W	
A22R17	0687-4721	R: fxd, comp, 4700 ohms $\pm$ 10%, 1/2 W	
A22R18	0687-1531	R: fxd, comp, 15K ohms $\pm$ 10%, 1/2 W	
A22R19	0687-1011	R: fxd, comp, 100 ohms $\pm$ 10%, 1/2 W	
A22R20	2100-0281	R: var, lin, ww, 100 ohms $\pm$ 20%, 1-1/2 W	
A22R21	0757-0730	R: fxd, met flm, 750 ohms $\pm$ 1%, 1/4 W	
A23, A24		Not assigned	
A25	00203-64201	Phase shifter, includes: C1 thru C3	
A25C1	0130-0015	C: var, cer, 9-50 pf	
A25C2, A25C3	0160-3132	C: fxd, cer, 200 pf $\pm$ 10%, 500 vdcw	
C1, C2	0180-0056	C: fxd, elect, 1000 $\mu$ f, 50 vdcw	
C3	0170-0022	C: fxd, mylar, 0.1 $\mu$ f $\pm$ 20%, 600 vdcw	

\*Average value shown, optimum value selected at factory

# See introduction to this section

Table 6-1. Reference Designation Index (Cont'd)

REFERENCE DESIGNATION	(hp) STOCK NO.	DESCRIPTION	NOTE
C4	0160-0151	C: fxd, cer, 4700pf -20% +80% 4000vdcw	
C5	0160-0151	C: fxd, cer, 4700pf -20% +80% 4000vdcw	
C6 thru C10		Not assigned	
C11	0121-0117	C: var, air, 12.5 to 86.9 pf	
C12*	0160-0378	C: fxd, dipped mica, 27 pf ±5%, 500 vdcw	
C13	0160-0905	C: fxd, cer, 33 pf ±2%, 600 vdcw	
C14	0140-0225	C: fxd, dipped mica, 300 pf ±1%, 300 vdcw	
C15	0121-0007	C: var, air, 3.6 pf to 26 pf, single sect	
DS1	2140-0058	Lamp, incandescent, 10 v at 0.040 amps	
F1	2110-0202	Fuse, 500mA for 230V operation	
	2110-0312	Fuse, 1A for 115V operation	
J1	1251-0148	Connector, power, receptacle, 3 pin male recessed chassis mounting	
J2 thru J5	0340-0086	Insulator, BP double, without locating key	
	0340-0090	Insulator, BP, with locating key	
	1510-0006	Binding post, black, without solder turret	
	1510-0007	Binding post, red, without solder turret	
L1	9140-0231	Coil, adjustable, inductance, 10.8 to 18.7 μh	
L2	9140-0230	Coil, fxd, inductance, 290 μh ±1%	
L3, L4	9140-0115	Coil, fxd R. F., 22 μh ±10%	
MP1	1500-0002	Yoke, coupler, for 1/4" shaft, p/o flexible coupler, keyed and staked	
MP2	5040-0212	Insulator, flex coupling	
MP3	5060-0021	Gear, ass'y	
MP4	5000-0637	Spring, thrust, vernier drive	
MP5	5060-0020	Gear, ass'y, with coupling hub	
MP6	5020-0233	Collar and stop, dial hub	
MP7	5020-0345	Shaft, pin dowel	
MP8	5020-0641	Shaft, spur gear	
MP9	5020-0639	Bearing, cap drive machine casting	
MP10	5020-0630	Hub, dial	
MP11	5040-0607	Disc ass'y, vernier drive	
Q1, Q2	1850-0038	Transistor, 2N301, PNP, germanium	
Q3	1850-0095	Transistor type 2N297A power, PNP germanium	
R1	0761-0054	R: fxd, met flm, 330 ohms ±5%, 1 W	
R2, R3	0768-0001	R: fxd, met, 1000 ohms ±10%, 3 W	
R4, R5	0764-0063	R: fxd, met flm, 620 ohms ±5%, 2 W	
R6	2100-0113	R: var, comp, dual tandem, 2 W	
R7, R8	0757-0728	R: fxd, met flm, 619 ohms ±1%, 1/4 W	
R9	2100-0113	R: var, comp, dual tandem, 2 W	
R10, R11	0757-0728	R: fxd, met flm, 619 ohms ±1%, 1/4 W	
R12	2100-0113	R: var, comp, dual tandem, 2 W	
R13, R14	0757-0728	R: fxd, met flm, 619 ohms ±1%, 1/4 W	
R15	2100-0113	R: var, comp, dual tandem, 2 W	
R16, R17	0757-0728	R: fxd; met flm, 619 ohms ±1%, 1/4 W	
S1A, B, C	3100-0841	Switch, multiplier	
S1C1, S1C2	0160-0170	C: fxd, cer, 0.22 μf +80% -20%, 25 vdcw	
S2	3101-1248	Switch, pushbutton	
S3	3101-1234	Switch, slide	
T1	9100-0293	Transformer, power	
W1	8120-1348	Cable ass'y, power	

# See introduction to this section

Table 6-1. Reference Designation Index (Cont'd)

REFERENCE DESIGNATION	STOCK NO.	DESCRIPTION	NOTE
<u>MISCELLANEOUS</u>			
	61B-40D-4	Plate, freq, dial	
	120A-47A	Spacer, binding post	
	0340-0090	Insulator, BP, with locating key	
	0370-0025	Knob, amplitude and frequency vernier	
	0370-0112	Knob, skirted bar, black, for 1/4" diam shaft (multiplier)	
	0370-0160	Knob (frequency dial)	
	1200-0043	Insulator, transistor, mtg, anodized Al plate (Q1, Q2, Q3)	
	1200-0081	Insulator, bushing nylon (Q1, Q2, Q3)	
	1251-0135	Connector, printed circuit, 15 tuning fork type contacts, terminal type B	
	1251-2357	Connector, power, receptacle, 3 pin male	
	1251-1031	Connector, printed circuit, 6 tuning fork type contacts, terminal 1, style d; 2 thru 6, style b	
	1251-0475	Connector, printed circuit, 6 tuning fork type contacts, terminal type B	
	1400-0084	Body, fuseholder	
	1410-0052	Bushing, cal adjust potentiometer, 0.435" OD x 0.438" lg	
	1460-0114	Spring, gear assembly	
	1490-0030	Stand, tilt, stainless steel rod 0.188" diam	
	1500-0004	Coupler, cal adjust insulator, 1/2" diam x 7/32" lg, nylon	
	1500-0005	Coupler, cal adjust hub, fits 1/4" diam shaft, nickel plated	
	1510-0006	Binding Post, black, without solder turret	
	1510-0007	Binding Post, red, without solder turret	
	1520-0001	Plate, mounting, bakelite, oval shape (C1, C2)	
	5000-0051	Plate, fluted Al	
	5000-0732	Rear side cover, 5 x 11 FM	
	5000-0733	Front side cover, 5 x 11 FM	
	5020-0241	Support, long res bd	
	5040-0619	Indicator, freq dial	
	5060-0222	Handle ass'y, side	
	5060-0625	Ass'y, connector	
	5060-0731	Frame ass'y, 5 x 11 FM	
	5060-0739	Top cover ass'y, 11L FM	
	5060-0751	Bottom cover ass'y, 11L FM	
	5060-0766	Retainer, 5H handle	
	5060-0767	Foot ass'y, FM	
	9211-0248	Carton, corrugated, 20-1/8" lg x 16-3/4" wd x 10-1/2" deep x 350 lb test	
	9223-0040	Foam, poly, 10-3/4" lg x 4" wd	
	00203-00101	Chassis, main	
	00203-00211	Panel, front	
	00203-00212	Panel, rear	
<u>ADDITIONAL PARTS FOR 203A OPTION:01</u>			
A17	00203-00213	Panel, front	
	00203-66501	Board, decade module	
<u>ADDITIONAL PARTS FOR 203A OPTION:02</u>			
A17, A18	00203-00214	Panel, front	
	00203-66501	Board, decade module	

# See introduction to this section

Table 6-2. Replaceable Parts

Stock No.	Description	Mfr.	Mfr. Part No.	TQ		
61B-40D-4	Plate, freq dial	28480	61B-40D-4	1		
120A-47A	Spacer, binding post	28480	120A-47A	1		
0121-0007	C: var, air, 3.6 pf to 26 pf, single sect	80486	CT2-0-25L	1		
0121-0117	C: var, air, 12.5 to 86.9 pf	77630	882758	1		
0130-0015	C: var, cer, 9-50 pf	72982	3192-000-U2PO-47R	1		
0130-0017	C: var, cer, 8-50 pf	72982	557-019-U2PO-34R	1		
0131-0003	C: var, mica, single sect, 170 - 180 pf, 175 vdcw	72136	T52910	1		
0140-0054	C: fxd, molded mica, 10 pf $\pm 10\%$	04062	RCM15E101K	1		
0140-0145	C: fxd, dipped mica, 22 pf $\pm 5\%$	04062	RDM15C220J5C	9		
0140-0151	C: fxd, dipped mica, 820 pf $\pm 2\%$ , 300 vdcw	14655	obd#	9		
0140-0152	C: fxd, mica, 1000 pf $\pm 5\%$ , 300 vdcw	04062	DM16F102J	10		
0140-0153	C: fxd, mica, 1269 pf $\pm 1\%$ , 300 vdcw	14655	CD20F1269F	2		
0140-0154	C: fxd, dipped mica, 1300 pf $\pm 5\%$ , 500 vdcw	14655	obd#	8		
0140-0156	C: fxd, dipped mica, 1500 pf $\pm 2\%$ , 300 vdcw	00853	obd#	13		
0140-0157	C: fxd, dipped mica, 1857 pf $\pm 1\%$ , 500 vdcw	14655	obd#	1		
0140-0161	C: fxd, dipped mica, 3932 pf $\pm 1\%$ , 300 vdcw	14655	obd#	2		
0140-0170	C: fxd, dipped mica, 5600 pf $\pm 5\%$ , 300 vdcw	00853	obd#	1		
0140-0176	C: fxd, dipped mica, 100 pf $\pm 2\%$ , 300 vdcw	00853	obd#	1		
0140-0178	C: fxd, dipped mica, 560 pf $\pm 2\%$ , 300 vdcw	00853	obd#	3		
0140-0182	C: fxd, dipped mica, 5000 pf $\pm 2\%$ , 300 vdcw	00853	obd#	1		
0140-0192	C: fxd, dipped mica, 68 pf $\pm 5\%$ , 300 vdcw	00853	obd#	6		
0140-0195	C: fxd, dipped mica, 130 pf $\pm 5\%$ , 300 vdcw	00853	obd#	12		
0140-0198	C: fxd, dipped mica, 200 pf $\pm 5\%$ , 300 vdcw	00853	obd#	12		
0140-0201	C: fxd, dipped mica, 12 pf $\pm 5\%$ , 500 vdcw	00853	obd#	1		
0140-0204	C: fxd, dipped mica, 47 pf $\pm 5\%$ , 500 vdcw	00853	obd#	1		
0140-0206	C: fxd, dipped mica, 270 pf $\pm 5\%$ , 500 vdcw	00853	obd#	2		
0140-0207	C: fxd, dipped mica, 330 pf $\pm 5\%$ , 500 vdcw	00853	obd#	1		
0140-0208	C: fxd, dipped mica, 680 pf $\pm 5\%$ , 300 vdcw	00853	obd#	1		
0140-0217	C: fxd, dipped mica, 140 pf $\pm 2\%$ , 300 vdcw	14655	obd#	2		
0140-0218	C: fxd, dipped mica, 160 pf $\pm 2\%$ , 300 vdcw	00853	obd#	6		
0140-0220	C: fxd, dipped mica, 200 pf $\pm 1\%$ , 300 vdcw	00853	obd#	1		
0140-0224	C: fxd, dipped mica, 280 pf $\pm 1\%$ , 300 vdcw	00853	obd#	6		
0140-0225	C: fxd, dipped mica, 300 pf $\pm 1\%$ , 300 vdcw	14655	obd#	5		
0150-0012	C: fxd, cer, 0.01 $\mu$ f $\pm 20\%$ , 1000 vdcw	71590	13 C Disc	9		
0150-0015	C: fxd, TiO <sub>2</sub> , 2.2 pf $\pm 10\%$ , 500 vdcw	82142	type JM	2		
0150-0047	C: fxd, TiO <sub>2</sub> , 6.8 pf $\pm 10\%$ , 500 vdcw	82142	type JM obd#	2		
0150-0069	C: fxd, cer, 0.001 $\mu$ f $\pm 100\%$ -20%, 500 vdcw	72982	#801-010x5G0102Z	1		
0150-0071	C: fxd, cer, 400 pf $\pm 5\%$ , 500 vdcw	56289	19C formulation 28	3		
0150-0093	C: fxd, 0.01 $\mu$ f $\pm 80\%$ -20%, 100 vdcw	91418	TA obd#	14		
0150-0096*	C: fxd, cer, 0.05 $\mu$ f $\pm 80\%$ -20%, 100 vdcw	94145	type TA	34		
0150-0115	C: fxd, cer, 27 pf $\pm 10\%$ , 500 vdcw	72982	301-000-U2JO-270K	1		
0160-0127*	C: fxd, cer, 1.0 $\mu$ f $\pm 20\%$ , 25 vdcw	56289	5C13	4		
0160-0147	C: fxd, dipped mica, 2500 pf $\pm 2\%$ , 300vdcw	00853	obd#	1		
0160-0151	C: fxd, cer, 4700pf -20% $\pm 80\%$ , 4000vdcw			2		
0160-0170	C: fxd, cer, 0.22 $\mu$ f $\pm 80\%$ -20%, 25vdcw	56289	5C9A	2		
0160-0174	C: fxd, cer, 0.47 $\mu$ f $\pm 80\%$ -20%, 25vdcw	56289	5C11A	8		
0160-0179	C: fxd, dipped mica, 33pf $\pm 5\%$ , 300vdcw	00853	obd#	6		

\* Average value shown, optimum value selected at factory  
# See introduction to this section

Table 6-2. Replaceable Parts (Cont'd)

Stock No.	Description	Mfr.	Mfr. Part No.	TQ		
0160-0182	C: fxd, dipped mica, 47 pf $\pm 5\%$ , 300 vdcw	00853	obd#	1		
0160-0217	C: fxd, dipped mica, 2300 pf $\pm 1\%$	04062	RDM20F232F3C	1		
0160-3132	C: fxd, cer, 200 pf $\pm 10\%$ , 500 vdcw	71590	Type CC32, TCN- 200	4		
0160-0905	C: fxd, cer, 33 pf $\pm 2\%$ , 600 vdcw	71590	CC20 33pf $\pm 2\%$ N750	1		
0170-0022	C: fxd, mylar, 0.1 $\mu f$ $\pm 20\%$ , 600 vdcw	56289	148P175A	1		
0180-0039	C: fxd, elect, 100 $\mu f$ , 12 vdcw	56289	D32697	1		
0180-0050	C: fxd, Al elect, 40 $\mu f$ -15% +100%, 50 vdcw	56289	D32538	3		
0180-0056	C: fxd, elect, 1000 $\mu f$ , 50 vdcw	56289	D32429	2		
0180-0059	C: fxd, elect, 10 $\mu f$ -10% +100%, 25 vdcw	56289	30D106G025BB4	2		
0180-0094	C: fxd, Al elect, 100 $\mu f$ -10% +100%, 25 vdcw	56289	30D107G025DH4	2		
0180-0105	C: fxd, Al elect, 50 $\mu f$ -10% +100%, 25 vdcw	56289	D34114	6		
0180-0114	C: fxd, Al elect, 4 $\mu f$ +100% -10%, 25 vdcw	56289	30D4057025BA4	1		
0180-0224	C: fxd, Al elect, 10 $\mu f$ -10% +75%, 15 vdcw	56289	30D106G015BA4	1		
0340-0086	Insulator, BP Double, without locating key	28480	0340-0086	4		
0340-0090	Insulator, BP, with locating key	28480	0340-0090	5		
0370-0025	Knob, amplitude and frequency vernier	28480	0370-0025	1		
0370-0112	Knob, skirted bar, black, for 1/4" diam shaft (multiplier)	28480	0370-0112	1		
0370-0160	Knob (frequency multiplier)	28480	0370-0160	1		
0410-0009	Crystal unit, quartz, 5 mc, 2 pins on bottom	0000Y	obd#	1		
0683-4715	R: fxd, comp, 470 ohms, $\pm 5\%$ , 1/4 W	01121	CB4715	1		
0686-6225	R: fxd, comp, 6200 ohms $\pm 5\%$ , 1/2 W	01121	EB-6225	1		
0687-1011	R: fxd, comp, 100 ohms $\pm 10\%$ , 1/2 W	01121	#EB1011	6		
0687-1021	R: fxd, comp, 1000 ohms $\pm 10\%$ , 1/2 W	01121	#EB1021	9		
0687-1031	R: fxd, comp, 10 K ohms $\pm 10\%$ , 1/2 W	01121	#EB1031	23		
0687-1051	R: fxd, comp, 1 M ohms $\pm 10\%$ , 1/2 W	01121	#EB1051	6		
0687-1061	R: fxd, comp, 10 M ohms $\pm 10\%$ , 1/2 W	01121	#EB1061	2		
0687-1231	R: fxd, comp, 12 K ohms $\pm 10\%$ , 1/2 W	01121	#EB1231	1		
0687-1521	R: fxd, comp, 1500 ohms $\pm 10\%$ , 1/2 W	01121	#EB1521	6		
0687-1531	R: fxd, comp, 15 K ohms $\pm 10\%$ , 1/2 W	01121	#EB1531	4		
0687-1821	R: fxd, comp, 1800 ohms $\pm 10\%$ , 1/2 W	01121	#EB1821	1		
0687-2221	R: fxd, comp, 2200 ohms $\pm 10\%$ , 1/2 W	01121	#EB2221	9		
0687-2231	R: fxd, comp, 22 K ohms $\pm 10\%$ , 1/2 W	01121	#EB2231	1		
0687-2711	R: fxd, comp, 270 ohms $\pm 10\%$ , 1/2 W	01121	#EB2711	1		
0687-2721	R: fxd, comp, 2700 ohms $\pm 10\%$ , 1/2 W	01121	#EB2721	2		
0687-3311	R: fxd, comp, 330 ohms $\pm 10\%$ , 1/2 W	01121	#EB3311	1		
0687-3921	R: fxd, comp, 3900 ohms $\pm 10\%$ , 1/2 W	01121	#EB3921	1		
0687-4701	R: fxd, comp, 47 ohms $\pm 10\%$ , 1/2 W	01121	#EB4701	1		
0687-4711	R: fxd, comp, 470 ohms $\pm 10\%$ , 1/2 W	01121	#EB4711	8		
0687-4721	R: fxd, comp, 4700 ohms $\pm 10\%$ , 1/2 W	01121	#EB4721	31		
0687-4731	R: fxd, comp, 47 K ohms $\pm 10\%$ , 1/2 W	01121	#EB4731	4		
0687-5621	R: fxd, comp, 5600 ohms $\pm 10\%$ , 1/2 W	01121	#EB5621	1		
0687-6811	R: fxd, comp, 680 ohms $\pm 10\%$ , 1/2 W	01121	EB6811	2		
0687-8211	R: fxd, comp, 820 ohms $\pm 10\%$ , 1/2 W	01121	#EB8211	4		
0687-8221	R: fxd, comp, 8200 ohms $\pm 10\%$ , 1/2 W	01121	#EB8221	2		
0699-0001	R: fxd, comp, 2.7 ohms $\pm 10\%$ , 1/2 W	01121	EB-27G1	2		
0699-0002	R: fxd, comp, 6.8 ohms $\pm 10\%$ , 1/2 W	01121	EB 68G1	1		
0757-0339	R: fxd, met flm, 3.01 K ohms $\pm 1\%$ , 1/4 W	19701	MF 6C T-O obd#	8		
0757-0715	R: fxd, met flm, 150 ohms $\pm 1\%$ , 1/4 W	75042	CEB T-O obd#	2		

# See introduction to this section

Table 6-2. Replaceable Parts (Cont'd)

Stock No.	Description	Mfr.	Mfr. Part No.	TQ
0757-0724	R: fxd, met flm, 392 ohms $\pm 1\%$ , 1/4 W	75042	CEB T-O obd#	1
0757-0728	R: fxd, met flm, 619 ohms $\pm 1\%$ , 1/4 W	75042	CEB T-O obd#	10
0757-0730	R: fxd, met flm, 750 ohms $\pm 1\%$ , 1/4 W	75042	CEB T-O obd#	2
0757-0732	R: fxd, met flm, 909 ohms $\pm 1\%$ , 1/4 W	75042	CEB T-O obd#	1
0757-0734	R: fxd, met flm, 1.21 K ohms $\pm 1\%$ , 1/4 W	75042	CEB T-O obd#	1
0757-0736	R: fxd, met flm, 1.5 K ohms $\pm 1\%$ , 1/4 W	75042	CEB T-O obd#	3
0757-0737	R: fxd, met flm, 1.62 K ohms $\pm 1\%$ , 1/4 W	75042	CEB T-O obd#	2
0757-0738	R: fxd, met flm, 1.82 K ohms $\pm 1\%$ , 1/4 W	75042	CEB T-O obd#	1
0757-0740	R: fxd, met flm, 2.21 K ohms $\pm 1\%$ , 1/4 W	75042	CEB T-O obd#	3
0757-0741	R: fxd, met flm, 2.43 K ohms $\pm 1\%$ , 1/4 W	75042	CEB T-O obd#	2
0757-0743	R: fxd, met flm, 3.32 K ohms $\pm 1\%$ , 1/4 W	75042	CEB T-O obd#	4
0757-0744	R: fxd, met flm, 3.92 K ohms $\pm 1\%$ , 1/4 W	75042	CEB T-O obd#	4
0757-0745	R: fxd, met flm, 4.32 K ohms $\pm 1\%$ , 1/4 W	75042	CEB T-O obd#	2
0757-0755	R: fxd, met flm, 12.1 K ohms $\pm 1\%$ , 1/4 W	75042	CEB T-O obd#	2
0757-0757	R: fxd, met flm, 15 K ohms $\pm 1\%$ , 1/4 W	75042	CEB T-O obd#	1
0757-0759	R: fxd, met flm, 18.2 K ohms $\pm 1\%$ , 1/4 W	75042	CEB T-O obd#	1
0757-0761	R: fxd, met flm, 22.1 K ohms $\pm 1\%$ , 1/4 W	75042	CEB T-O obd#	16
0757-0762	R: fxd, met flm, 24.3 K ohms $\pm 1\%$ , 1/4 W	75042	CEB T-O obd#	2
0757-0766	R: fxd, met flm, 39.2 K ohms $\pm 1\%$ , 1/4 W	75042	CEB T-O obd#	2
0757-0768	R: fxd, met flm, 47.5 K ohms $\pm 1\%$ , 1/4 W	75042	CEB T-O obd#	3
0757-0771	R: fxd, met flm, 61.9 K ohms $\pm 1\%$ , 1/4 W	75042	CEB T-O obd#	2
0757-0772	R: fxd, met flm, 68.1 K ohms $\pm 1\%$ , 1/4 W	75042	CEB T-O obd#	2
0757-0774	R: fxd, met flm, 82.5 K ohms $\pm 1\%$ , 1/4 W	75042	CEB T-O obd#	1
0757-0777	R: fxd, met flm, 121 K ohms $\pm 1\%$ , 1/4 W	75042	CEB T-O obd#	2
0757-1027	R: fxd, met flm, 680 ohms $\pm 1\%$ , 1/4 W	75042	CEB obd#	2
0757-1032	R: fxd, met flm, 100 ohms $\pm 0.5\%$ , 1/4 W	75042	CEB T-O obd#	1
0757-1033	R: fxd, met flm, 200 ohms $\pm 0.5\%$ , 1/4 W	75042	CEB T-O obd#	1
0757-1040	R: fxd, met flm, 50 ohms $\pm 1\%$ , 1/4 W	75042	CEB T-O obd#	4
0757-1050	R: fxd, met flm, 150 ohms $\pm 1\%$ , 1/2 W	19701	MF7C T-2	2
0758-0017	R: fxd, met flm, 1500 ohms $\pm 5\%$ , 1/2 W	07115	C20	1
0758-0041	R: fxd, met flm, 91 ohms $\pm 5\%$ , 1/2 W	07115	C20	2
0761-0022	R: fxd, met flm, 620 ohms $\pm 5\%$ , 1 W	07115	C32	1
0761-0054	R: fxd, met flm, 330 ohms $\pm 5\%$ , 1 W	07115	C32	1
0764-0063	R: fxd, met flm, 620 ohms $\pm 5\%$ , 2 W	28480	0764-0063	2
0768-0001	R: fxd, met, 1000 ohms $\pm 10\%$ , 3 W	76055	3MOL	2
1200-0043	Insulator, transistor, mtg, anodized Al plate (Q1, Q2, Q3)	28480	1200-0043	3
1200-0081	Insulator, bushing, nylon (Q1, Q2, Q3)	26365	974 Special	6
1205-0033	Heat dissipater, semiconductor (A6Q5)	28480	1205-0033	1
1251-0135	Connector, printed circuit, 15 tuning fork type contacts, terminal type B	000XX	SD 615 UR	5
1251-2357	Connector, power			1
1251-0475	Connector, printed circuit, 6 tuning fork type contacts, terminal type B	02660	143-006-08(109)	13
1251-1031	Connector, printed circuit, 6 tuning fork type contacts, terminal 1, style d; 2 thru 6, style b	000XX	SD-606UR-TS1	1
1400-0084	Body, fuseholder			1
1410-0052	Bushing, potentiometer, 0.435" OD x 0.438" lg	28480	1410-0052	1

# See introduction to this section

Table 6-2. Replaceable Parts (Cont'd)

Stock No.	Description	Mfr.	Mfr. Part No.	TQ		
1490-0030	Stand, tilt, stainless steel rod 0.188" diam	91260	obd#	1		
1500-0002	Yoke, coupler, for 1/4" shaft, p/o flexible coupler, keyed and staked	76487	obd#	2		
1500-0004	Coupler, insulator, 1/2" diam x 7/32" lg, nylon	99934	obd#	1		
1500-0005	Coupler, hub, fits 1/4" diam shaft, nickel plated	99934	obd#	2		
1510-0006	Binding Post, black, without solder turret	28480	1510-0006	5		
1510-0007	Binding Post, red, without solder turret	28480	1510-0007	5		
1520-0001	Plate, mounting, bakelite, oval shape (C1, C2)	56137	Grade XP	2		
1850-0038	Transistor, 2N301, PNP germanium	28480	1850-0039	5		
1850-0040	Transistor, PNP germanium	28480	1850-0040	7		
1850-0095	Transistor, type 2N297A power, PNP germanium	16758	2N297A	1		
1851-0017	Transistor, EIA type 2N1304, NPN germanium	01295	2N1304	1		
1853-0008	Transistor, EIA type 2N3250, PNP silicon	04713	2N3250	4		
1853-0009	Transistor, PNP silicon	04713	SM3197	2		
1853-0016	Transistor, 2N3638, PNP silicon	28480	1853-0016	5		
1854-0005	Transistor, EIA type 2N708, NPN silicon planar	86684	2N708	26		
1854-0014	Transistor, silicon, dual NPN silicon, special	00872	SA2015	4		
1854-0033	Transistor, EIA type 2N3391, NPN silicon	24446	obd#	16		
1854-0039	Transistor, EIA type 2N3053, NPN silicon	86684	2N2270	10		
1901-0025	Diode, silicon, 50 MA at +1 v, 100 PIV, 12 pf	03877	SG-817	4		
1901-0026	Diode, silicon, rectifier, 200 PIV, 0.5 amp	14099	SA783	4		
1901-0040	Diode, silicon, 30 MA at +1 v, 30 PIV, 2 pf, 2 ns	03877	SG5050	11		
1901-0049	Diode, silicon, rectifier, 50 PIV, 0.5 amp	86684	34934	2		
1902-0761	Diode, breakdown, EIA type 1N821, 5.9 to 6.5 v, 0.01%/°C	03877	1N821	1		
1910-0016	Diode, germanium, 100 MA at +0.85 v, 60 v working	11711	GD 150	12		
2100-0094	R: var, lin, comp, 50 K ohms, 30%, 1/5 W	28480	2100-0094	2		
2100-0113	R: var, comp, 2 W, dual tandem	01121	JJ59160	4		
2100-0206	R: var, lin, ww, 50 ohms ±10%, 1 W	11236	Series 110	2		
2100-0281	R: var, lin, ww, 100 ohms ±20%, 1-1/2 W	11236	Series 110	2		
2100-0282	R: var, lin, ww, 2000 ohms ±20%, 1-1/2 W	11236	Series 110	5		
2100-0908	R: var, comp, lin, 2 K ±30%, 1/4 W	76055	MTC-1 obd#	2		
2100-0909	R: var, comp, lin, 100 ohms ±30%, 1/4 W	76055	MTC-1 obd#	2		
2110-0202	Fuse, 500mA			1		
2110-0312	Fuse, 1A			1		
2140-0058	Lamp, incandescent, 10v at 0.040 amps	94154	367	1		
3100-0841	Switch, Multiplier	76854	obd#	3		
3101-1234	Switch, slide			1		
3101-1248	Switch, pushbutton			1		
5000-0051	Plate, fluted Al	28480	5000-0051	1		
5000-0637	Spring, thrust	28480	5000-0637	1		
5000-8597	Rear side cover, 5 x 11 FM	28480	5000-8597	1		
5000-8599	Front side cover, 5 x 11 FM	28480	5000-8599	1		
5020-0233	Collar	28480	5020-0233	1		
5020-0241	Support, long res bd	28480	5020-0241	1		
5020-0345	Pin, dowell	28480	5020-0345	1		
5020-0630	Hub, dial	28480	5020-0630	1		

# See introduction to this section



Table 6-2. Replaceable Parts (Cont'd)

Stock No.	Description	Mfr.	Mfr. Part No.	TQ		
5020-0639	Bearing, cap drive	28480	5020-0639	1		
5020-0641	Shaft, spur gear	28480	5020-0641	1		
5040-0212	Insulator, flex coupling	28480	5040-0212	1		
5040-0607	Disc ass'y, vernier drive	28480	5040-0607	1		
5040-0619	Indicator, freq dial	28480	5040-0619	1		
5060-0020	Gear, ass'y with coupling hub	28480	5060-0020	1		
5060-0021	Gear, ass'y	28480	5080-0021	1		
5080-0222	Handle ass'y, side	28480	5060-0222	2		
5060-0625	Ass'y, connector	28480	5080-0625	1		
5060-0731	Frame ass'y, 5 x 11 FM	28480	5060-0731	2		
5080-0739	Top cover ass'y, 11L FM	28480	5060-0739	1		
5060-0751	Bottom cover ass'y, 11L FM	28480	5060-0751	1		
5060-0766	Retainer, 5H handle	28480	5060-0766	2		
5060-0767	Foot ass'y, FM	28480	5060-0767	5		
8120-1348	Cable ass'y, power			1		
9100-0293	Transformer, power	28480	5080-3423	1		
9140-0029	Coil, R. F., choke, universal wound, unshielded, 100 $\mu$ h, 2.6 ohms	28480	9140-0029	7		
9140-0031	Coil, R. F., 75 $\mu$ h	28480	9140-0031	1		
9140-0037	Coil, radio freq 5 mh induct, universal wound	99848	35000-15-502	5		
9140-0041	Coil, R. F., 2.5 mh $\pm$ 10%	95265	SA-2500-I	1		
9140-0115	Coil, fxd R. F., 22 $\mu$ h $\pm$ 10%	76493	9330-32	2		
9140-0137	Coil, fxd R. F., 1000 $\mu$ h $\pm$ 5%, dc current rating 135 ma	76493	9220-28	4		
9140-0230	Coil, fxd, inductance, 290 $\mu$ h $\pm$ 1%	28480	9140-0230	1		
9140-0231	Coil, adjustable, inductance, 10.8 to 18.7 $\mu$ h	28480	9140-0231	1		
9211-0248	Carton, corrugated, 20-1/8" lg x 16-3/4" wd x 10-1/2" deep x 350 lb test	84324	obd#	1		
9223-0040	Foam, poly, 10-3/4" lg x 4" wd	28480	9223-0040	4		
00203-00101	Chassis, main	28480	00203-00101	1		
00203-00211	Panel, front	28480	00203-00211	1		
00203-00212	Panel, rear for 115/230v operation only	28480	00203-00212	1		
00203-00216	Panel, rear for 100 v operation only	28480	00203-00216	1		
00203-64201	Phase shifter	28480	00203-64201	1		
00203-66501	Board ass'y, decade module	28480	00203-66501	6		
00203-66502	Board ass'y, square wave	28480	00203-66502	2		
00203-66503	Board ass'y, 5 mcps	28480	00203-66503	1		
00203-86504	Board ass'y, dc amplifier	28480	00203-66504	2		
00203-66505	Board ass'y, power supply	28480	00203-66505	1		
00203-66506	Board ass'y, R. F. Amplifier	28480	00203-66506	1		
00203-66507	Board, ass'y, modulator	28480	00203-66507	1		
00203-68508	Board ass'y, V. F. O.	28480	00203-66508	1		
00203-66510	Board ass'y, rectifier	28480	00203-66510	1		
00203-68511	Board ass'y, filter	28480	00203-66511	2		
00203-84201	Transformer, tuned	28480	00203-84201	8		
00203-84202	Transformer, tuned	28480	00203-84202	6		
00203-84203	Transformer, tuned	28480	00203-84203	1		
00203-84204	Transformer, tuned	28480	00203-84204	1		
00203-84205	Transformer, tuned	28480	00203-84205	1		
00203-84206	Transformer, tuned	28480	00203-84206	1		
00203-86001	Coil, var, 2.5 - 6.2 $\mu$ h	28480	00203-86001	6		
00203-86002	Coil, var, 650 - 1100 $\mu$ h	28480	00203-86002	6		

# See introduction to this section

Table 6-2. Replaceable Parts (Cont'd)

Stock No.	Description	Mfr.	Mfr. Part No.	TQ		
00203-86003	Coil, var, 35 - 80 $\mu$ h	28480	00203-86003	1		
00203-86004	Transformer, driver	28480	00203-86004	2		
00203-86005	Transformer, driver	28480	00203-86005	2		
00203-86006	Coil, fxd, 4.5 mh	28480	00203-86006	6		
00203-86009	Coil, var, 650 - 1100 $\mu$ h	28480	00203-86009	1		
00203-86010	Coil, var, 35 - 80 $\mu$ h	28480	00203-86010	1		
<u>Additional Parts for 203A Option: 01</u>						
00203-00213	Panel, front	28480	00203-00213	1		
00203-66501	Board, decade module	28480	00203-66501	1		
<u>Additional Parts for 203A Option: 02</u>						
00203-00214	Panel, front	28480	00203-00214	1		
00203-66501	Board, decade module	28480	00203-66501	2		

# See introduction to this section



# MANUAL BACKDATING CHANGES

MODEL 203A

VARIABLE PHASE FUNCTION GENERATOR

Manual Serial Prefixed: 1201J-  
-hp- Part No. 00203-99002

This manual backdating sheet makes this manual applicable to earlier instruments. Instrument-component values that differ from those in the manual, yet are not listed in the backdating sheet, should be replaced using the part number given in the manual.

Instrument Serial Prefix	Make Manual Changes	Instrument Serial Prefix	Make Manual Changes
425-00770 and below	1, 2, 3, 4	1201J-02534 and below	4
425-00771 to-008865	2, 3, 4		
621, 714, 821	2, 3, 4,		
1019J and below	3, 4		

**CHANGE #1**

Current Part No. for Transistor A2Q3, A2Q4, A2Q7 and A2Q8 is 1853-0016, 2N3638 and is a recommended replacement for Part No. 1853-0009, 2N274. If either one of these transistors is replaced with the current 2N3638, the other three should also be replaced and inductors L1 and L2 replaced with a 56 ohm resistor, -hp- Part No. 0687-5601.

This recommended change is to improve phase stability at high temperatures.

**CHANGE #2**

Change: S2 and S3 to HP Part No. 3101-0100 and 3101-0033, respectively (Page 6-10, Table 6-1 and Page 6-15, Table 6-2).

Change: W1 to HP Part No. 8120-0078 (Page 6-10, Table 6-1 and Page 6-16, Table 6-2).

**Miscellaneous Parts Change**

Change: HP Part No. 1251-2357 (connector, power) to 1251-0148 (Page 6-11, Table 6-1 and Page 6-14, Table 6-2).

Change: HP Part No. 1400-0084 (Body, fuseholder) to 1400-0110 (Page 6-11, Table 6-1 and Page 6-14, Table 6-2).

Add: Nut, retaining for 1400-0110, HP Part No. 1400-0111 (Page 6-11, Table 6-1 and Page 6-14, Table 6-2).

Add: Knob, fuseholder black for 1400-0110, HP Part No. 1400-0210 (Page 6-11, Table 6-1 and Page 6-14, Table 6-2).

Change: HP Part No. 00203-00211 (Panel, front) to 00203-00201 (Page 6-11, Table 6-1 and Page 6-16, Table 6-2).

Change: HP Part No. 00203-00212 (Panel, rear) to 00203-00202 (Page 6-11, Table 6-1 and Page 6-16, Table 6-2).

Change: HP Part No. 00203-00213 (Panel, front) to 00203-00203 (Page 6-11, Table 6-1 and Page 6-17, Table 6-2).

Change: HP Part No. 00203-00214 (Panel, front) to 00203-00204 (Page 6-11, Table 6-1 and Page 6-17, Table 6-2).

Delete C4 C5 and thru C10

Add C4 A, B 0150-0119 C: fxd, cer, 2 x 0.1  $\mu$ f  $\pm$ 20%, 250vdcw

Add C5 thru C10 Not assigned

## CHANGE #3

Change: HP Part No. 5000-8597 (Side Cover) to 5000-0732 (Page 6-15, Table 6-2).  
Change: HP Part No. 5000-8599 (Side Cover) to 5000-0733 (Page 6-15, Table 6-2).  
Change: HP Part No. 5060-8587 (Top Cover Ass'y) to 5060-0739 (Page 6-16, Table 6-2).  
Change: HP Part No. 5060-8711 (Bottom Cover Ass'y) to 5060-0751 (Page 6-16, Table 6-2).  
Change: HP Part No. 5060-8737 (Retainer) to 5060-0766 (Page 6-16, Table 6-2).  
Change: HP Part No. 8120-1378 (Power Cord) to 8120-1348 (Page 6-16, Table 6-2).  
Change: HP Part No. 00203-00311 (Front Panel) to 00203-00211 (Page 6-16, Table 6-2).  
Change: HP Part No. 00203-00313 (Front Panel for OPT 001) to 00203-00213 (Page 6-16, Table 6-2).  
Change: HP Part No. 00203-00314 (Front Panel for OPT 002) to 00203-00214 (Page 6-16, Table 6-2).

## CHANGE #4

Change: HP Part No. 0160-0378 (C12) to 0140-0145 (Page 6-10, Table 6-1 and Page 5-21, Figure 5-14).