



**FCC 47 CFR PART 15 SUBPART C  
INDUSTRY CANADA RSS-247 ISSUE 1**

**BLUETOOTH LOW ENERGY  
CERTIFICATION TEST REPORT**

**FOR**

**TABLET DEVICE**

**MODEL NUMBER: A1550**

**FCC ID: BCGA1550  
IC: 579C-A1550**

**REPORT NUMBER: 14U19187-E2, REVISION B**

**ISSUE DATE: JUNE 17, 2015**

*Prepared for*  
**APPLE, INC.  
1 INFINITE LOOP  
CUPERTINO, CA 95014, U.S.A.**

*Prepared by*  
**UL VERIFICATION SERVICES INC.  
47173 BENICIA STREET  
FREMONT, CA 94538, U.S.A.  
TEL: (510) 771-1000  
FAX: (510) 661-0888**



**NVLAP LAB CODE 200065-0**

Revision History

<u>Rev.</u>	<u>Issue Date</u>	<u>Revisions</u>	<u>Revised By</u>
--	04/21/2015	Initial Issue	T. Chan
A	06/01/2015	Revised report to RSS-247 standard and Section 2 and Section 7.1	T. Chu
B	06/17/2015	Updated Section 7.1 KDB version	T. Chu

## TABLE OF CONTENTS

<b>1. ATTESTATION OF TEST RESULTS .....</b>	<b>5</b>
<b>2. TEST METHODOLOGY .....</b>	<b>6</b>
<b>3. FACILITIES AND ACCREDITATION .....</b>	<b>6</b>
<b>4. CALIBRATION AND UNCERTAINTY .....</b>	<b>7</b>
4.1. MEASURING INSTRUMENT CALIBRATION .....	7
4.2. SAMPLE CALCULATION .....	7
4.3. MEASUREMENT UNCERTAINTY.....	7
<b>5. EQUIPMENT UNDER TEST .....</b>	<b>8</b>
5.1. DESCRIPTION OF EUT .....	8
5.2. MAXIMUM OUTPUT POWER.....	8
5.3. DESCRIPTION OF AVAILABLE ANTENNAS .....	8
5.4. SOFTWARE AND FIRMWARE.....	8
5.5. WORST-CASE CONFIGURATION AND MODE.....	9
5.1. DESCRIPTION OF TEST SETUP.....	10
<b>6. TEST AND MEASUREMENT EQUIPMENT .....</b>	<b>14</b>
<b>7. ON TIME, DUTY CYCLE AND MEASUREMENT METHODS .....</b>	<b>15</b>
7.1. MEASUREMENT METHODS .....	15
7.2. ON TIME AND DUTY CYCLE RESULTS.....	16
7.3. DUTY CYCLE PLOTS .....	16
<b>8. ANTENNA PORT TEST RESULTS .....</b>	<b>17</b>
8.1. ANTENNA B.....	17
8.1.1. 6 dB BANDWIDTH.....	17
8.1.2. 99% BANDWIDTH.....	20
8.1.3. OUTPUT POWER .....	23
8.1.4. AVERAGE POWER .....	24
8.1.5. POWER SPECTRAL DENSITY .....	25
8.1.6. CONDUCTED SPURIOUS EMISSIONS.....	28
8.1. ANTENNA D.....	32
8.1.1. 6 dB BANDWIDTH.....	32
8.1.2. 99% BANDWIDTH.....	35
8.1.3. OUTPUT POWER .....	38
8.1.4. AVERAGE POWER .....	39
8.1.5. POWER SPECTRAL DENSITY .....	40
8.1.6. CONDUCTED SPURIOUS EMISSIONS.....	43
<b>9. RADIATED TEST RESULTS.....</b>	<b>47</b>
9.1. LIMITS AND PROCEDURE.....	47

---

9.2.	TRANSMITTER ABOVE 1 GHz BLUETOOTH LOW ENERGY.....	48
9.2.1.	MODE IN THE 2.4 GHz BAND ANTENNA B .....	48
9.2.2.	MODE IN THE 2.4 GHz BAND ANTENNA D .....	58
9.3.	WORST-CASE BELOW 1 GHz.....	68
9.4.	WORST-CASE ABOVE 18 GHz .....	72
9.5.	AC POWER LINE CONDUCTED EMISSIONS .....	74
<b>10.</b>	<b>SETUP PHOTOS .....</b>	<b>78</b>

# 1. ATTESTATION OF TEST RESULTS

**COMPANY NAME:** APPLE  
1 INFINITE LOOP  
CUPERTINO, CA 95014, U.S.A.

**EUT DESCRIPTION:** TABLET DEVICE

**MODEL:** A1550 **Error! Reference source not found.**

**SERIAL NUMBER:** F4KPC009GJK2(CONDUCTED); F4KP604KGJK5 (RADIATED);

**DATE TESTED:** FEBRUARY 17, 2015 – MARCH 12, 2015

APPLICABLE STANDARDS	
STANDARD	TEST RESULTS
CFR 47 Part 15 Subpart C	Pass
INDUSTRY CANADA RSS-247 Issue 1	Pass
INDUSTRY CANADA RSS-GEN Issue 4	Pass

UL Verification Services Inc. tested the above equipment in accordance with the requirements set forth in the above standards. All indications of Pass/Fail in this report are opinions expressed by UL Verification Services Inc. based on interpretations and/or observations of test results. Measurement Uncertainties were not taken into account and are published for informational purposes only. The test results show that the equipment tested is capable of demonstrating compliance with the requirements as documented in this report.

**Note:** The results documented in this report apply only to the tested sample, under the conditions and modes of operation as described herein. This document may not be altered or revised in any way unless done so by UL Verification Services Inc. and all revisions are duly noted in the revisions section. Any alteration of this document not carried out by UL Verification Services Inc. will constitute fraud and shall nullify the document. This report must not be used by the client to claim product certification, approval, or endorsement by NVLAP, NIST, any agency of the Federal Government, or any agency of any government.

Approved & Released For  
UL Verification Services Inc. By:

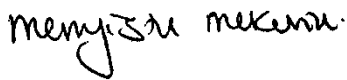

MENGISTU MEKURIA  
EMC SUPERVISOR  
UL Verification Services Inc.

Tested By:



TRI PHAM  
EMC ENGINEER  
UL Verification Services Inc.

## 2. TEST METHODOLOGY

The tests documented in this report were performed in accordance with FCC CFR 47 Part 2, FCC CFR 47 Part 15, RSS-GEN Issue 4, and RSS-247 Issue 1, and ANSI C63.10-2009 for FCC test and ANSI C63.10-2013 with deviation of measurement height of 0.8m rather than 1.5m for IC test.

## 3. FACILITIES AND ACCREDITATION

The test sites and measurement facilities used to collect data are located at 47173 and 47266 Benicia Street, Fremont, California, USA. Line conducted emissions are measured only at the 47173 address. The following table identifies which facilities were utilized for radiated emission measurements documented in this report. Specific facilities are also identified in the test results sections.

47173 Benicia Street	47266 Benicia Street
<input type="checkbox"/> Chamber A	<input type="checkbox"/> Chamber D
<input type="checkbox"/> Chamber B	<input checked="" type="checkbox"/> Chamber E
<input type="checkbox"/> Chamber C	<input type="checkbox"/> Chamber F
	<input type="checkbox"/> Chamber G
	<input type="checkbox"/> Chamber H

The above test sites and facilities are covered under FCC Test Firm Registration # 208313. Chambers A through H are covered under Industry Canada company address code 2324B with site numbers 2324B -1 through 2324B-8, respectively.

UL Verification Services Inc. is accredited by NVLAP, Laboratory Code 200065-0. The full scope of accreditation can be viewed at <http://ts.nist.gov/standards/scopes/2000650.htm>.

## 4. CALIBRATION AND UNCERTAINTY

### 4.1. MEASURING INSTRUMENT CALIBRATION

The measuring equipment utilized to perform the tests documented in this report has been calibrated in accordance with the manufacturer's recommendations, and is traceable to recognized national standards.

### 4.2. SAMPLE CALCULATION

Where relevant, the following sample calculation is provided:

$$\begin{aligned} \text{Field Strength (dBuV/m)} &= \text{Measured Voltage (dBuV)} + \text{Antenna Factor (dB/m)} + \\ &\text{Cable Loss (dB)} - \text{Preamp Gain (dB)} \\ 36.5 \text{ dBuV} + 18.7 \text{ dB/m} + 0.6 \text{ dB} - 26.9 \text{ dB} &= 28.9 \text{ dBuV/m} \end{aligned}$$

### 4.3. MEASUREMENT UNCERTAINTY

Where relevant, the following measurement uncertainty levels have been estimated for tests performed on the apparatus:

PARAMETER	UNCERTAINTY
Conducted Disturbance, 0.15 to 30 MHz	± 3.52 dB
Radiated Disturbance, 30 to 1000 MHz	± 4.94 dB
Radiated Disturbance, 1 to 6 GHz	± 3.86 dB
Radiated Disturbance, 6 to 18 GHz	± 4.23 dB
Radiated Disturbance, 18 to 26 GHz	± 5.30 dB
Radiated Disturbance, 26 to 40 GHz	± 5.23 dB

Uncertainty figures are valid to a confidence level of 95%.

## 5. EQUIPMENT UNDER TEST

### 5.1. DESCRIPTION OF EUT

The EUT is a tablet with multimedia functions (music, application support, and video), Cellular GSM/GPRS/EGPRS/CDMA2000 1xRTT/1x Advanced/EVDO Rev.A/EVDO Rev.B /WCDMA /HSPA+/DC-HSDPA/LTE FDD & Carrier Aggregation/TDD/TD-SCDMA radio, IEEE 802.11a/b/g/n/ac radio, and Bluetooth radio. The rechargeable battery is not user accessible.

### 5.2. MAXIMUM OUTPUT POWER

The transmitter has a maximum peak conducted output power as follows:

Frequency Range (MHz)	Mode	Antenna B Output Power (dBm)	Antenna B Output Power (mW)	Antenna D Output Power (dBm)	Antenna D Output Power (mW)
2402 - 2480	BLE	9.15	8.22	6.64	4.61

### 5.3. DESCRIPTION OF AVAILABLE ANTENNAS

Frequency Band (GHz)	Antenna Gain	
	Antenna B	Antenna D
2.4	-1.00	2.50

### 5.4. SOFTWARE AND FIRMWARE

The firmware installed in the EUT during testing was 12H33.



## 5.5. WORST-CASE CONFIGURATION AND MODE

Radiated emission and power line conducted emission were performed with the EUT set to transmit at the channel with highest output power as worst-case scenario.

The following configurations were investigated and EUT powered by AC/DC adapter was the worst-case scenario. AC power line and below 1G radiated tests were conducted on configuration 1.

Configuration	Descriptions
1	EUT powered by AC/DC adapter via USB cable
2	EUT powered by host PC via USB cable

The fundamental of the EUT was investigated in three orthogonal orientations X/Y/Z, it was determined that X-flatbed orientation was worst-case orientation; therefore, all final radiated testing was performed with the EUT in X-flatbed orientation.

EUT supports BT/BLE operation on antenna B or antenna D, testing was performed on both antenna B and antenna D.

Worst-case data rates as provided by the client were:

BLE: 1 Mbps.

## 5.1. DESCRIPTION OF TEST SETUP

### SUPPORT EQUIPMENT

Support Equipment List				
Description	Manufacturer	Model	Serial Number	FCC ID
Laptop AC/DC adapter	Lenovo	92P1160	11S92P1160Z1ZBGH798B12	NA
Laptop	Lenovo	7659	L3-AL664 08/03	NA
Earphone	Apple	NA	NA	NA
EUT AC/DC adapter	Apple	MD836LL/A	NA	NA

### I/O CABLES (CONDUCTED TEST)

I/O Cable List						
Cable No	Port	# of identical ports	Connector Type	Cable Type	Cable Length (m)	Remarks
1	Antenna	1	SMA	Un-Shielded	0.2	To spectrum Analyzer
2	USB	1	USB	Shielded	1	N/A

### I/O CABLES (RADIATED ABOVE 1 GHZ)

I/O Cable List						
Cable No	Port	# of identical ports	Connector Type	Cable Type	Cable Length (m)	Remarks
None used						

### I/O CABLES (AC POWER CONDUCTED TEST and below 1 GHZ)

I/O Cable List						
Cable No	Port	# of identical ports	Connector Type	Cable Type	Cable Length (m)	Remarks
1	AC	1	US115	Un-Shielded	0.8	NA
2	DC	1	lightning	Un-Shielded	1	NA
3	Audio	1	Jack	Un-Shielded	0.5	NA

**TEST SETUP- CONDUCTED PORT**

The EUT was tested connected to a host Laptop via USB cable adapter and spectrum analyzer to antenna port. Test software exercised the EUT.

**SETUP DIAGRAM**

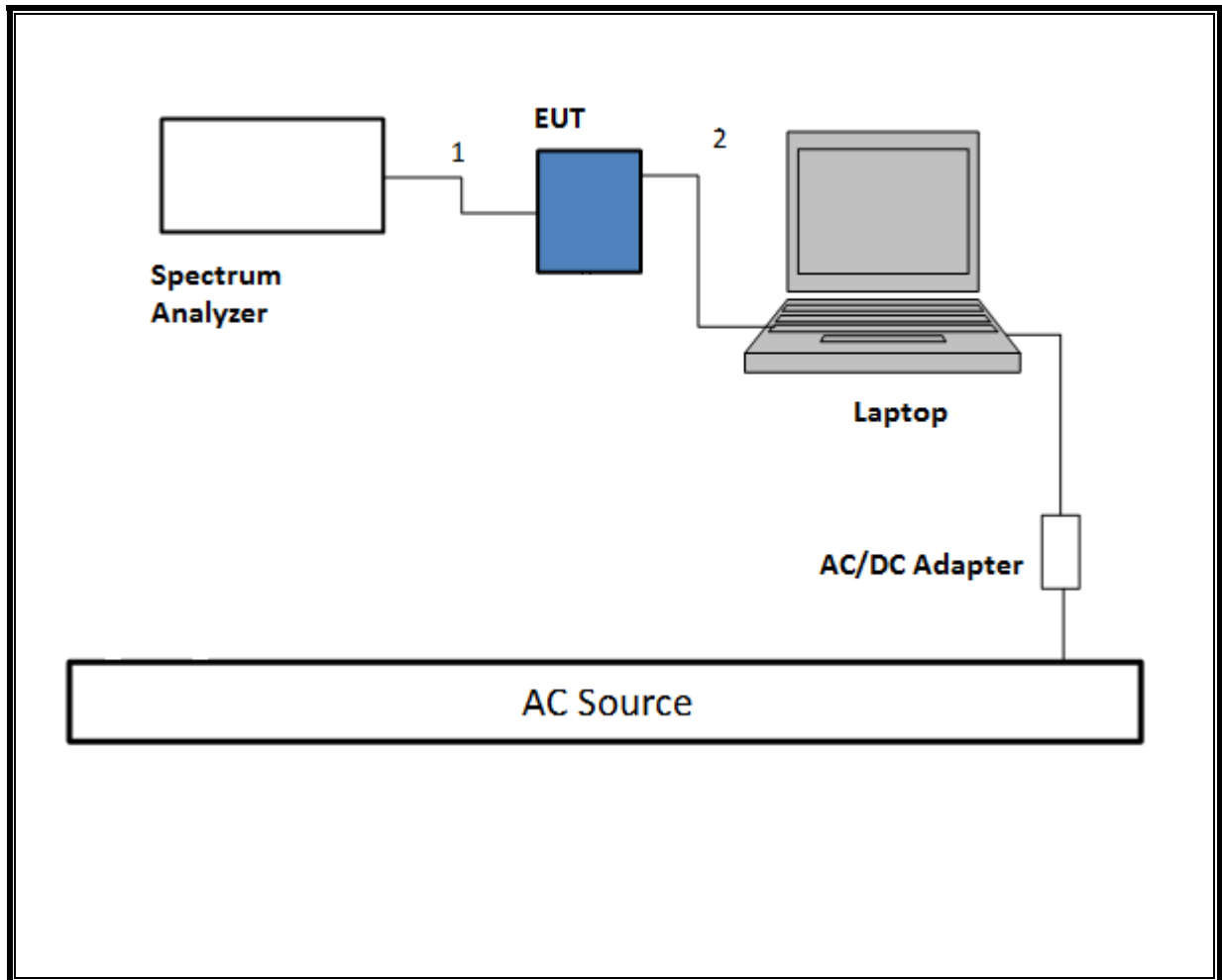

**TEST SETUP- RADIATED-ABOVE 1 GHZ**

The EUT was tested battery powered. Test software exercised the EUT.

**SETUP DIAGRAM**

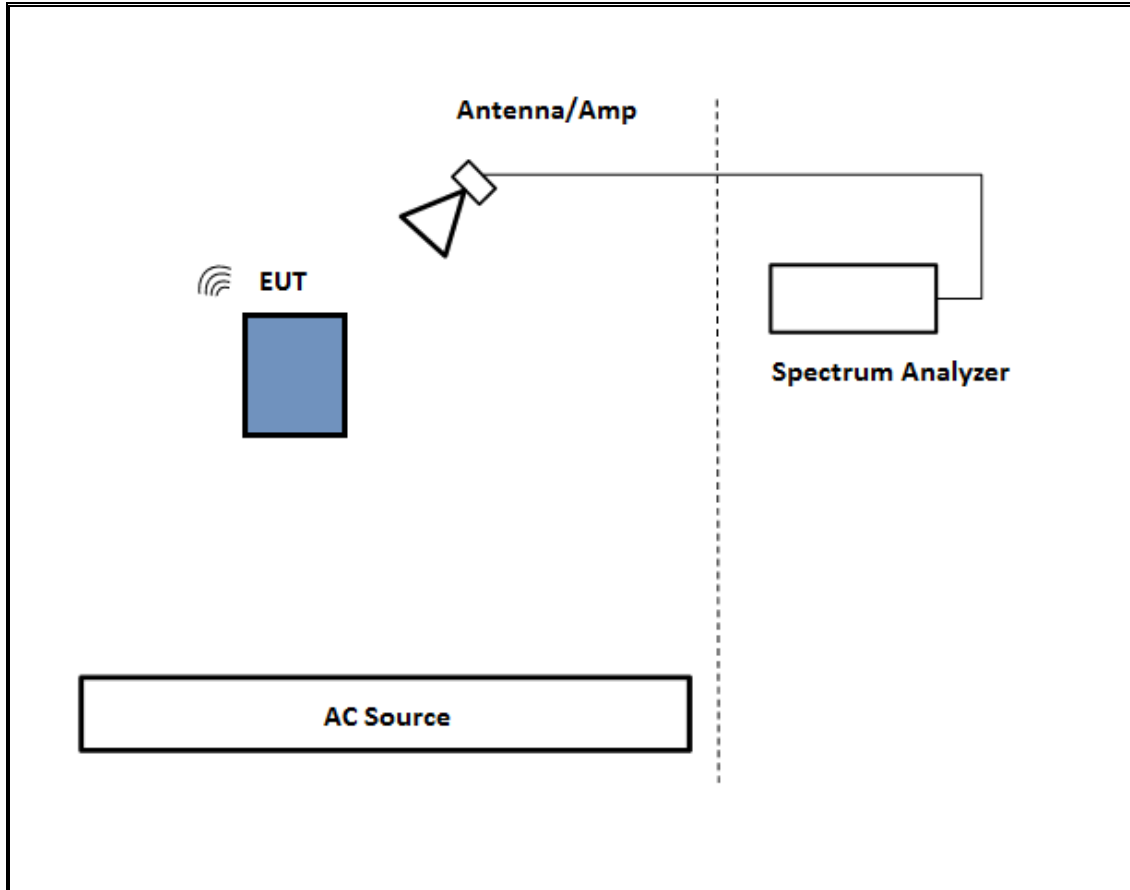

**TEST SETUP- BELOW 1GHZ & AC LINE CONDUCTED TESTS**

The EUT was tested with earphone connected and powered by AC adapter. Test software exercised the EUT.

**SETUP DIAGRAM**

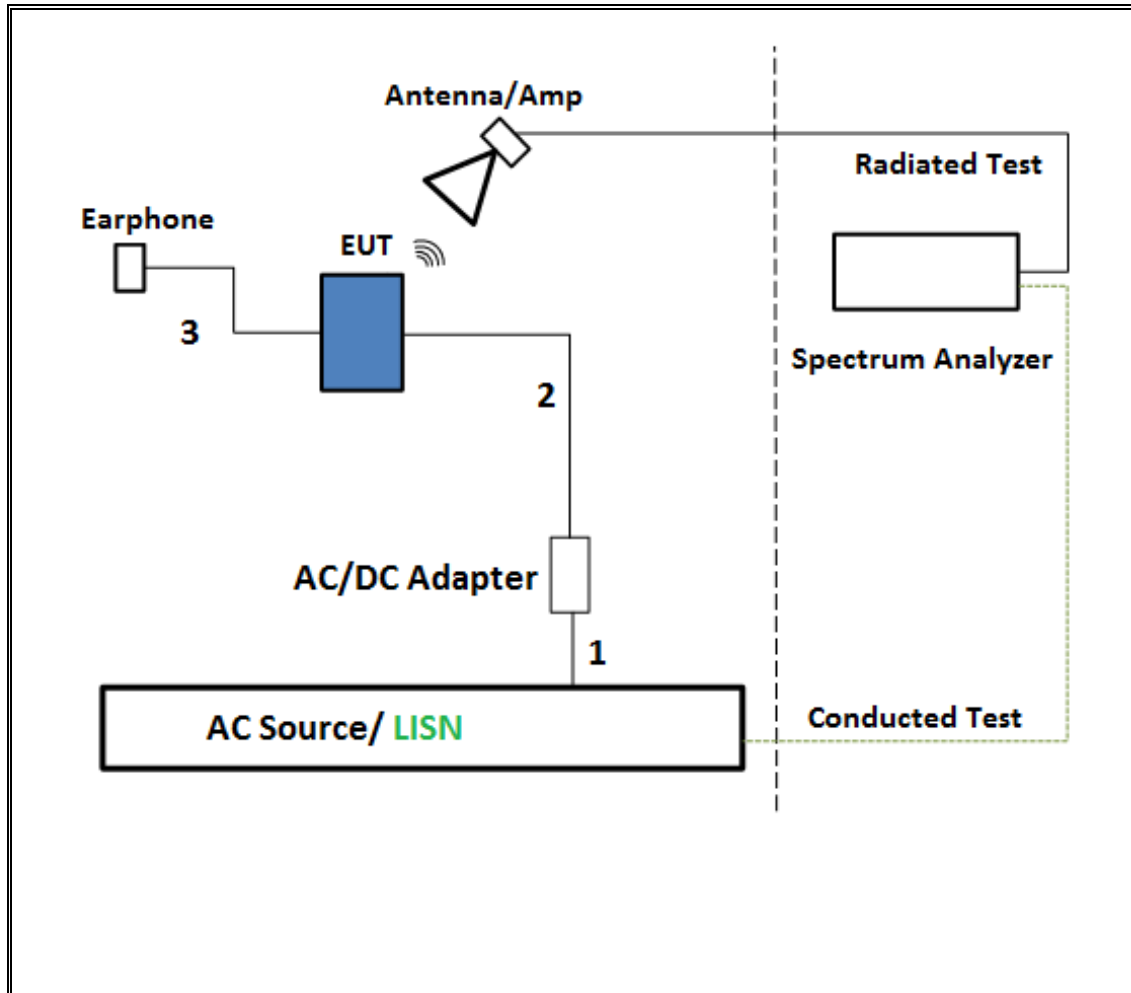

## 6. TEST AND MEASUREMENT EQUIPMENT

The following test and measurement equipment was utilized for the tests documented in this report:

Test Equipment List				
Description	Manufacturer	Model	Asset	Cal Due
Antenna, Horn 1-18GHz	ETS Lindgren	3117	00143449	2/10/2016
Antenna, Broadband Hybrid, 30MHz to 2000MHz	Sunol Sciences	JB3	A022813-1	1/14/2016
Amplifier, 1 - 18GHz	Miteq	AFS42-00101800-25-S-42	1782158	1/26/2016
Amplifier, 10KHz to 1GHz, 32dB	Sonoma	310N	323561	5/28/2015
Spectrum Analyzer, PXA, 3Hz to 44GHz	Agilent	N9030A	US51350187	5/2/2015
Antenna, Broadband Hybrid, 30MHz to 2000MHz	Sunol Sciences	JB1	A121003	2/13/2016
Amplifier, 10KHz to 1GHz, 32dB	Sonoma	310N	185623	6/7/2015
Spectrum Analyzer, PXA, 3Hz to 44GHz	Agilent	N9030A	MY51380911	2/20/2016
Power Meter, P-series single channel	Agilent	N1911A	GB45100212	10/9/2015
Power Sensor, P - series, 50MHz to 18GHz, Wideband	Agilent	N1921A	MY53260010	7/12/2015
Antenna, Horn 18 to 26.5GHz	ARA	MWH-1826	1049	12/17/2015
Spectrum Analyzer, 40 GHz	Agilent	8564E	3943A01643	8/6/2015
Amplifier, 1 to 26.5GHz, 23.5dB Gain minimum	Agilent	8449B	3008A01114	10/4/2015
AC Line Conducted				
EMI Test Receiver 9KHz-7GHz	Rohde & Schwarz	ESCI7	100935	9/16/2015
LISN for Conducted Emissions CISPR-16	FCC	50/250-25-2	114	1/16/2016
Power Cable, Line Conducted Emissions ANSI 63.4	UL	PG1	N/A	7/28/2015
UL SOFTWARE				
Radiated Software	UL	UL EMC	Ver 9.5, July 22, 2014	
Conducted Software	UL	UL EMC	Ver 2.2, March 31, 2015	
AC Line Conducted Software	UL	UL EMC	Ver 9.5, April 3, 2015	

## 7. ON TIME, DUTY CYCLE AND MEASUREMENT METHODS

### 7.1. MEASUREMENT METHODS

6 dB BW: KDB 558074 D01 v03r03, Section 8.1.

Output Power: KDB 558074 D01 v03r03, Section 9.1.2.

Power Spectral Density: KDB 558074 D01 v03r03, Section 10.2.

Out-of-band emissions in non-restricted bands: KDB 558074 D01 v03r03, Section 11.0.

Out-of-band emissions in restricted bands: KDB 558074 D01 v03r03, Section 12.1.

Band-edge: KDB 558074 D01 v03r03, Section 12.1





## 8. ANTENNA PORT TEST RESULTS

### 8.1. ANTENNA B

#### 8.1.1. 6 dB BANDWIDTH

##### LIMITS

FCC §15.247 (a) (2)

IC RSS-247 (5.2) (1)

The minimum 6 dB bandwidth shall be at least 500 kHz.

##### RESULTS

Channel	Frequency (MHz)	6 dB Bandwidth (MHz)	Minimum Limit (MHz)
Low	2402	723.8000	0.5
Middle	2440	715.4000	0.5
High	2480	722.4000	0.5

**6 dB BANDWIDTH**

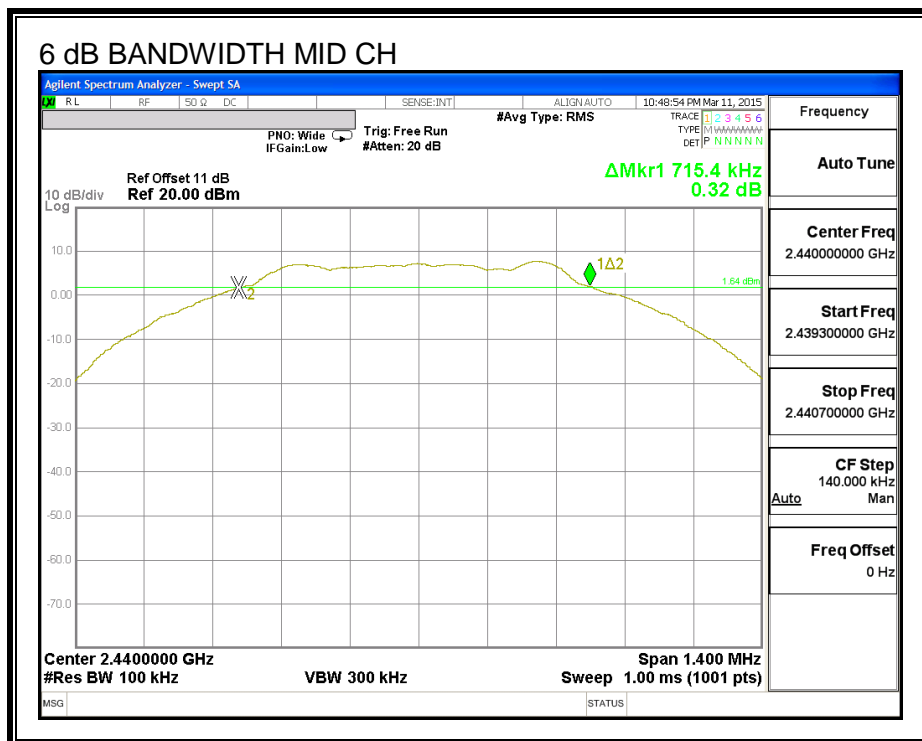
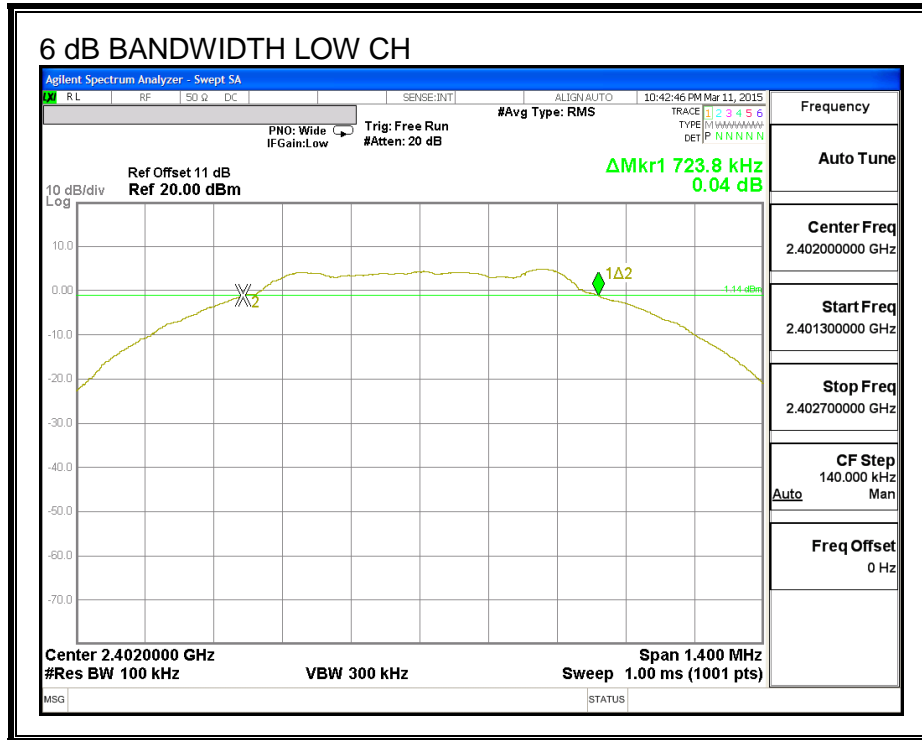

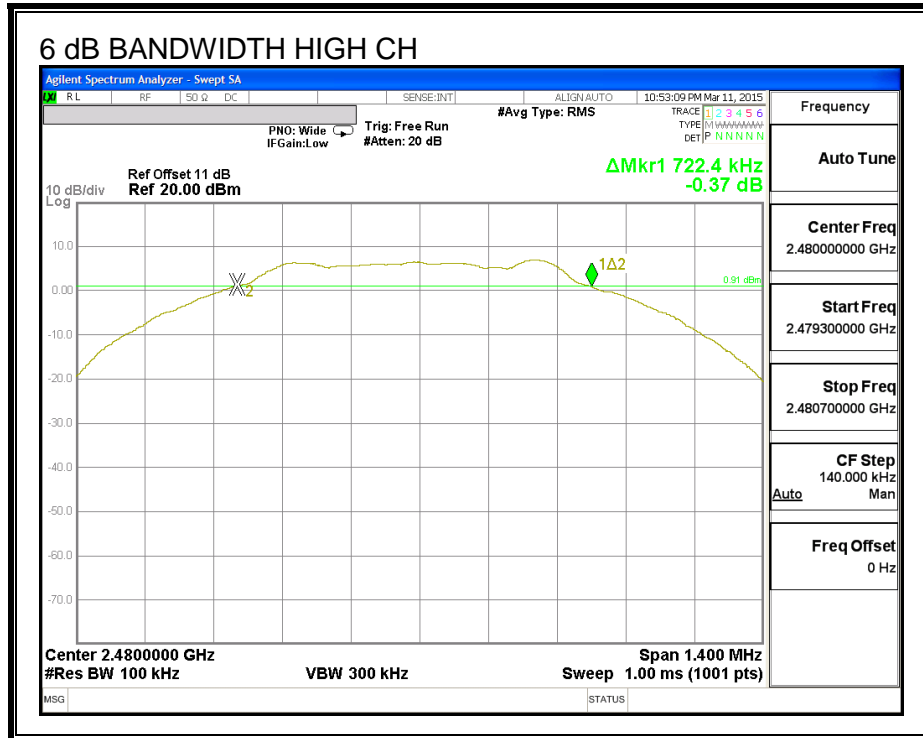

### 8.1.2. 99% BANDWIDTH

#### LIMITS

None; for reporting purposes only.

#### TEST PROCEDURE

The transmitter output is connected to the spectrum analyzer. The RBW is set to 1% to 3% of the 99 % bandwidth and to 1% of the span. The VBW is set to 3 times the RBW. The sweep time is coupled. The spectrum analyzer internal 99% bandwidth function is utilized.

#### RESULTS

Channel	Frequency (MHz)	99% Bandwidth (MHz)
Low	2402	1.0712
Middle	2440	1.0682
High	2480	1.0742

**99% BANDWIDTH**

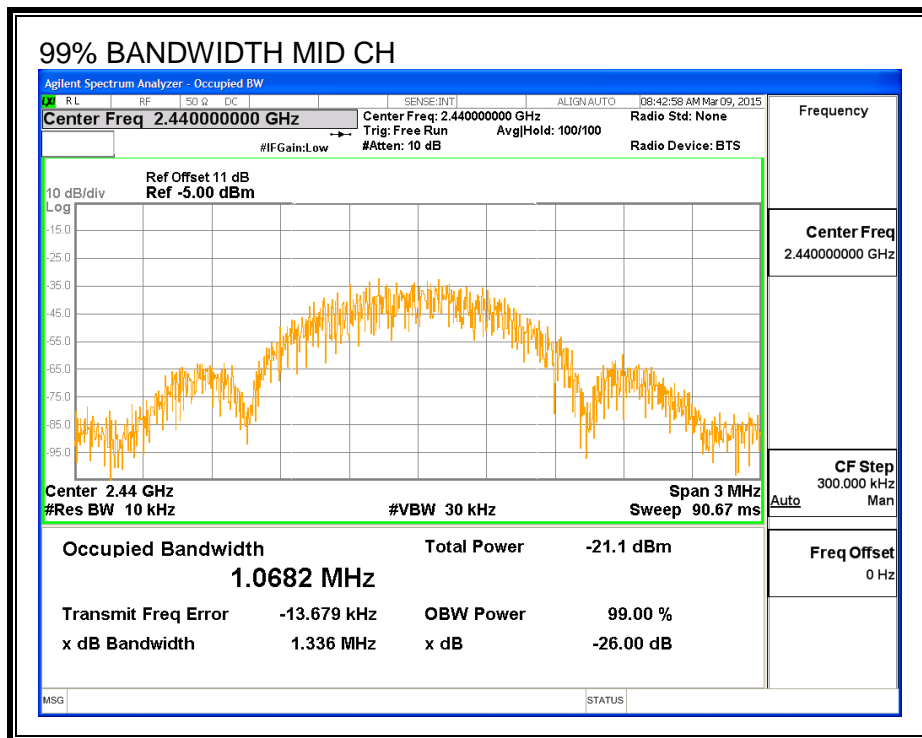
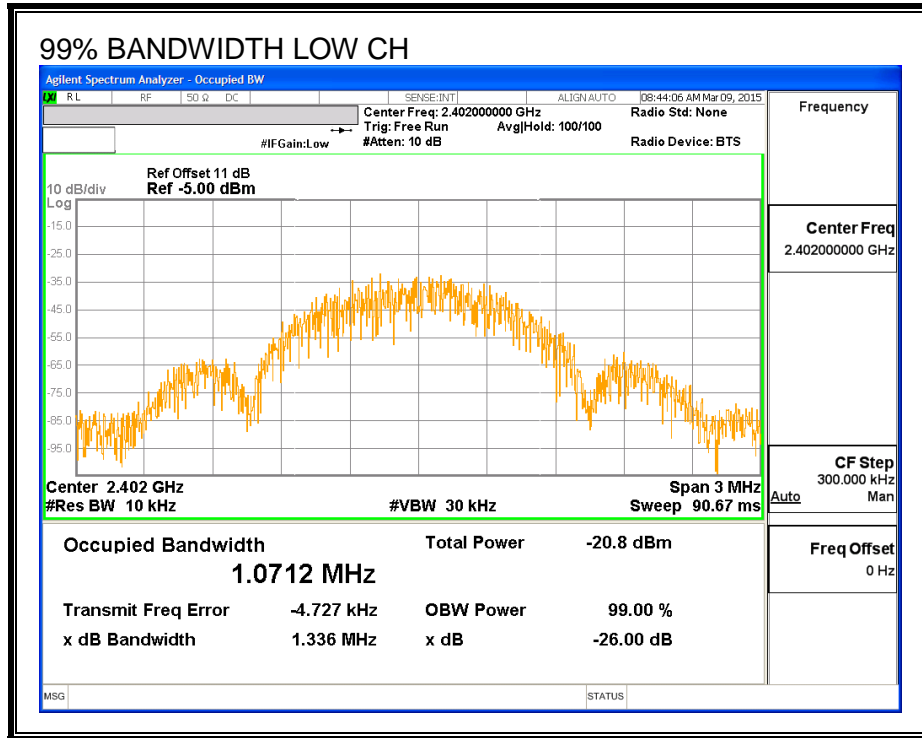

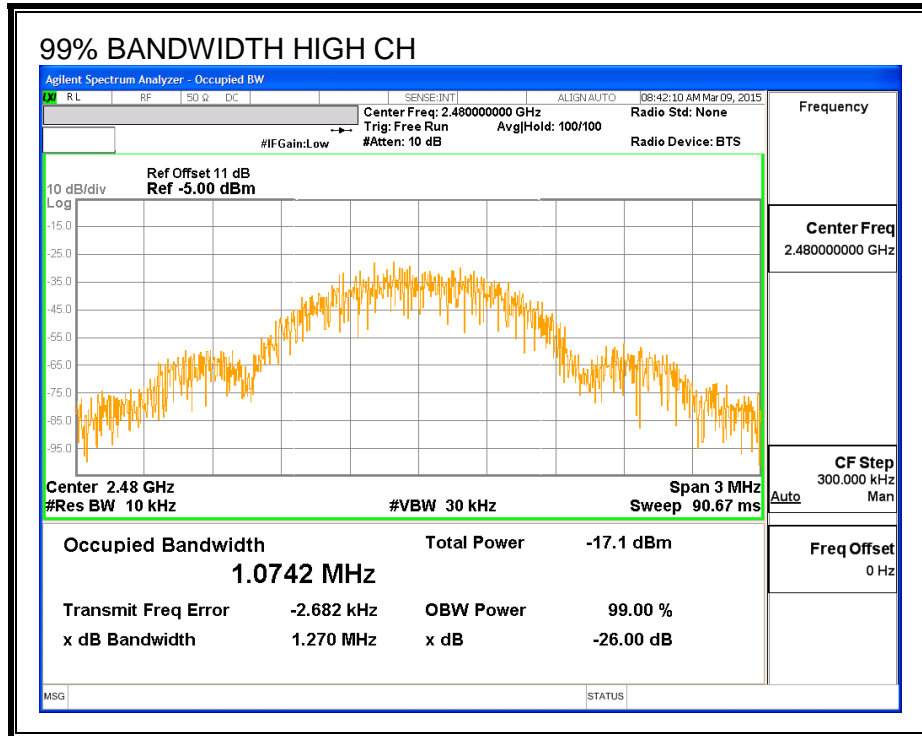

### 8.1.3. OUTPUT POWER

#### LIMITS

FCC §15.247 (b)

IC RSS-247 (5.4) (4)

The maximum antenna gain is less than or equal to 6 dBi, therefore the limit is 30 dBm.

#### TEST PROCEDURE

The transmitter output is connected to a wideband peak and average power meter.

#### RESULTS

Channel	Frequency (MHz)	Peak Power Reading (dBm)	Limit (dBm)	Margin (dB)
Low	2402	9.030	30	-20.970
Middle	2440	9.140	30	-20.860
High	2480	9.150	30	-20.850

### 8.1.4. AVERAGE POWER

#### LIMITS

None; for reporting purposes only.

#### RESULTS

The cable assembly insertion loss of 10.5 dB (including 10 dB pad and 0.5 dB cable) was entered as an offset in the power meter to allow for direct reading of power.

Channel	Frequency (MHz)	Average Power (dBm)
Low	2402	8.88
Middle	2440	8.98
High	2480	8.99



### 8.1.5. POWER SPECTRAL DENSITY

#### LIMITS

FCC §15.247 (e)

IC RSS-247 (5.2) (2)

The power spectral density conducted from the transmitter to the antenna shall not be greater than 8 dBm in any 3 kHz band during any time interval of continuous transmission.

#### RESULTS

Channel	Frequency (MHz)	PSD (dBm)	Limit (dBm)	Margin (dB)
Low	2402	-7.49	8	-15.49
Middle	2440	-7.50	8	-15.50
High	2480	-7.44	8	-15.44

**POWER SPECTRAL DENSITY**

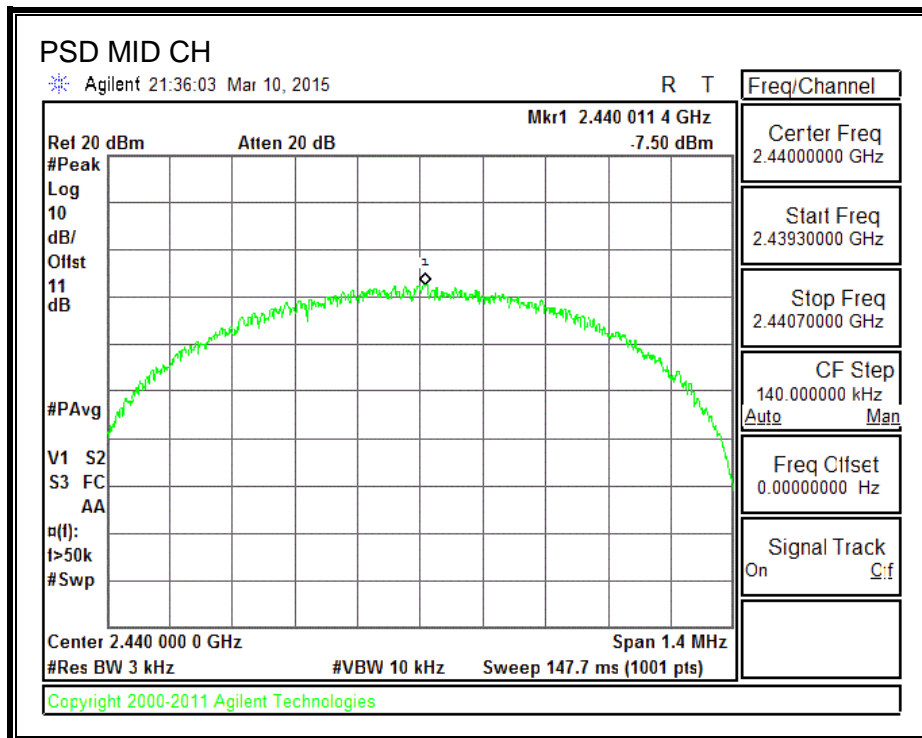
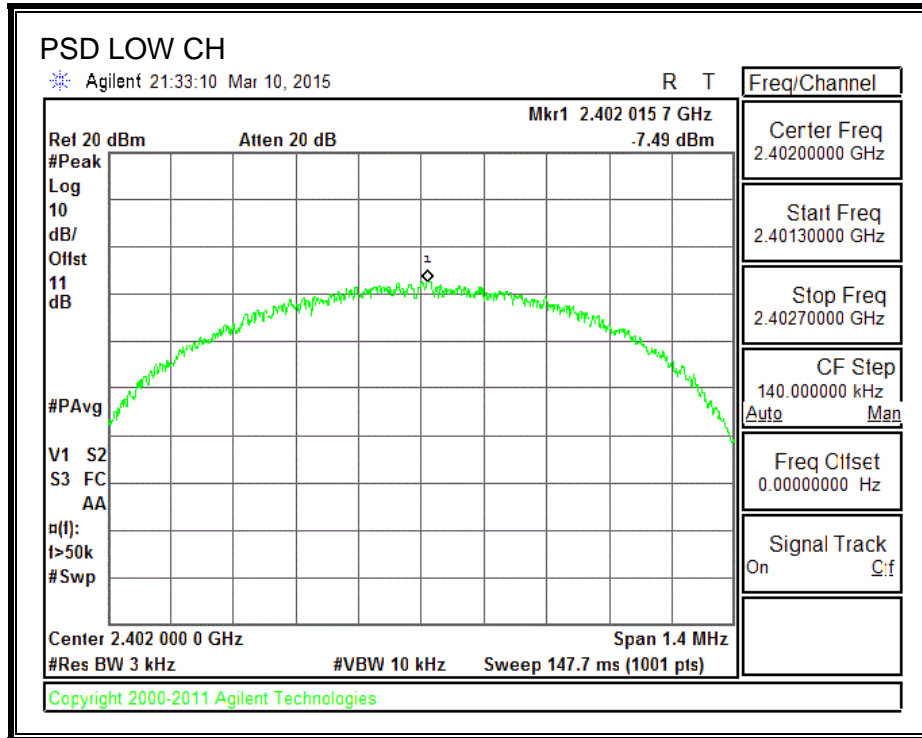

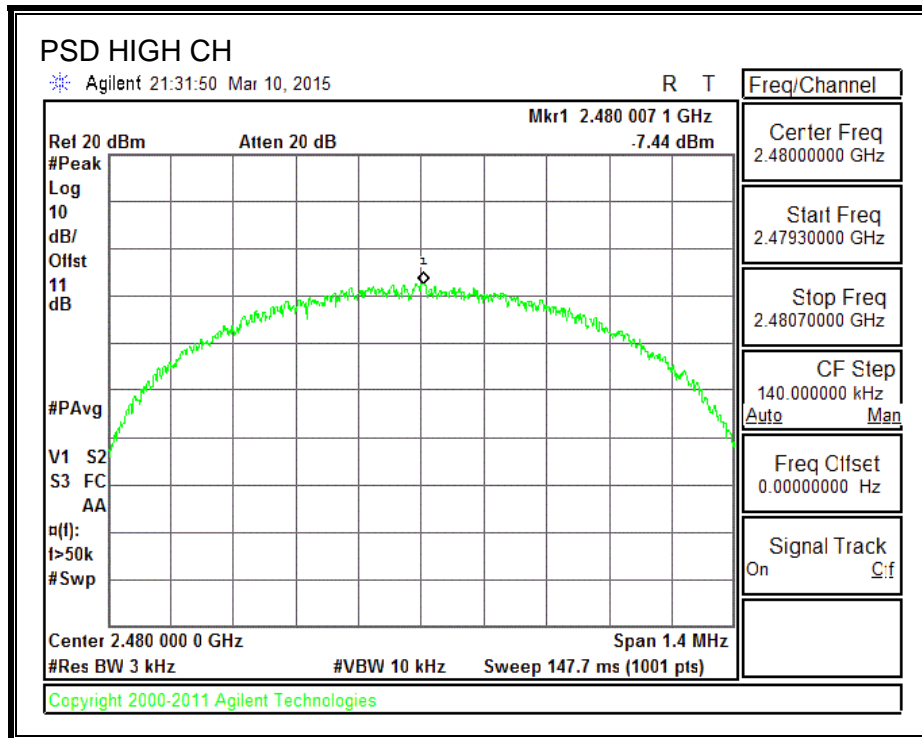

## **8.1.6. CONDUCTED SPURIOUS EMISSIONS**

### **LIMITS**

FCC §15.247 (d)

IC RSS-247 (5.5)

Output power was measured based on the use of a peak measurement, therefore the required attenuation is 20 dB.

### **TEST PROCEDURE**

The transmitter output is connected to a spectrum analyzer. The resolution bandwidth is set to 100 kHz. The video bandwidth is set to 300 kHz.

The spectrum from 30 MHz to 26 GHz is investigated with the transmitter set to the lowest, middle, and highest channels.

### **RESULTS**

**SPURIOUS EMISSIONS, LOW CHANNEL**

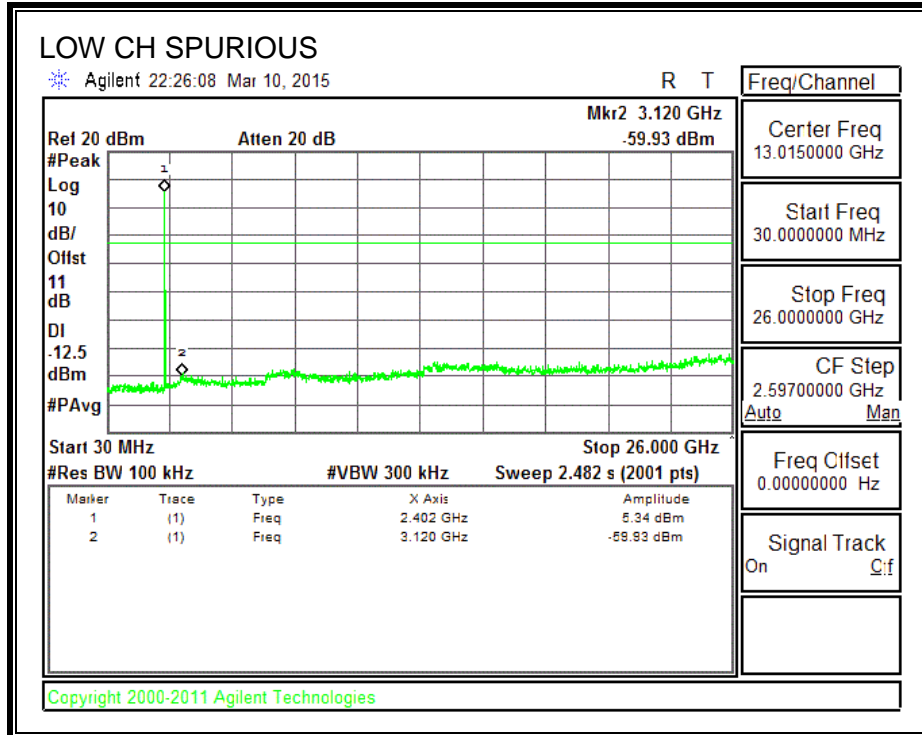
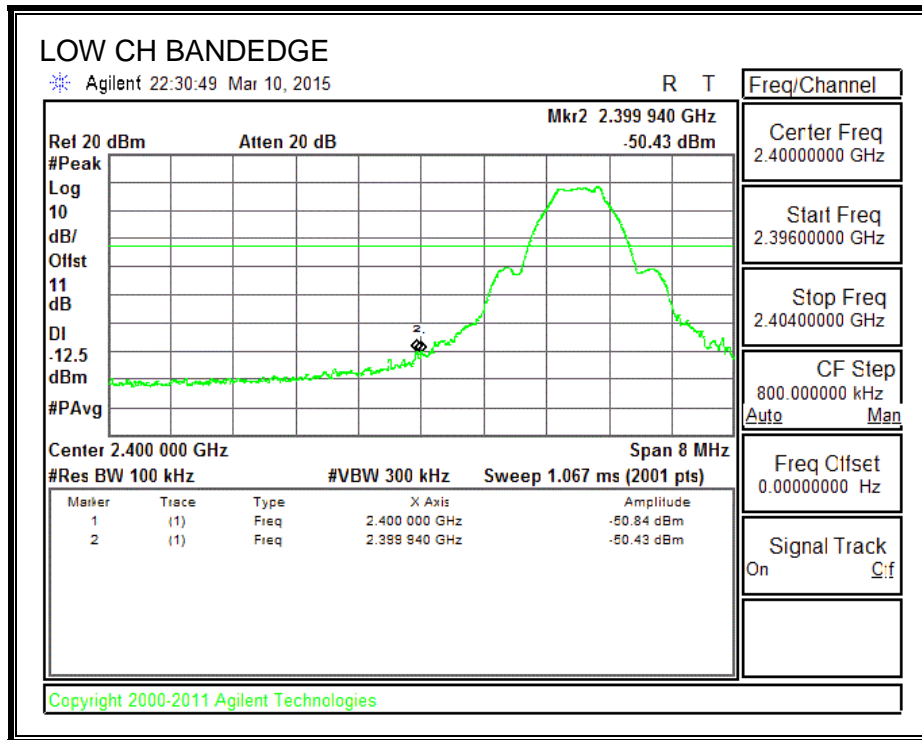

**SPURIOUS EMISSIONS, HIGH CHANNEL**

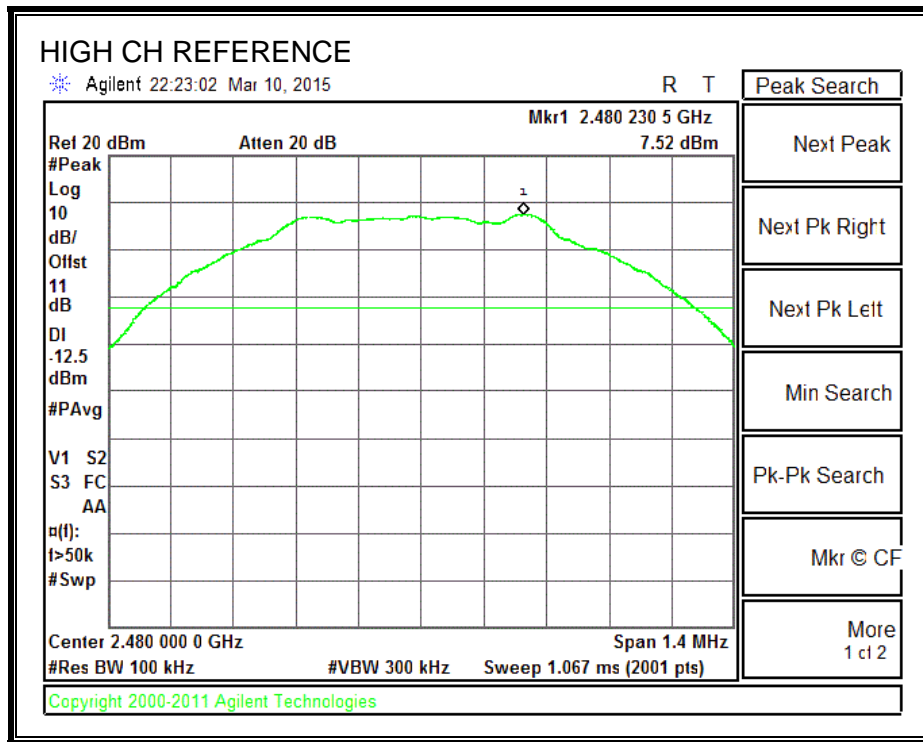

**SPURIOUS EMISSIONS, MID CHANNEL**

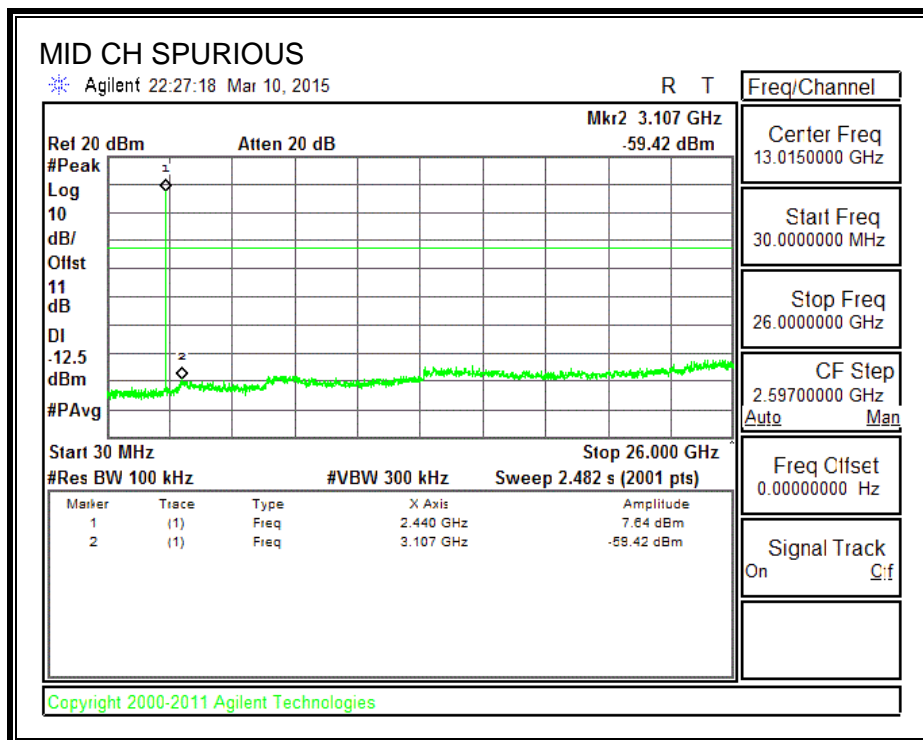

**SPURIOUS EMISSIONS, HIGH CHANNEL**

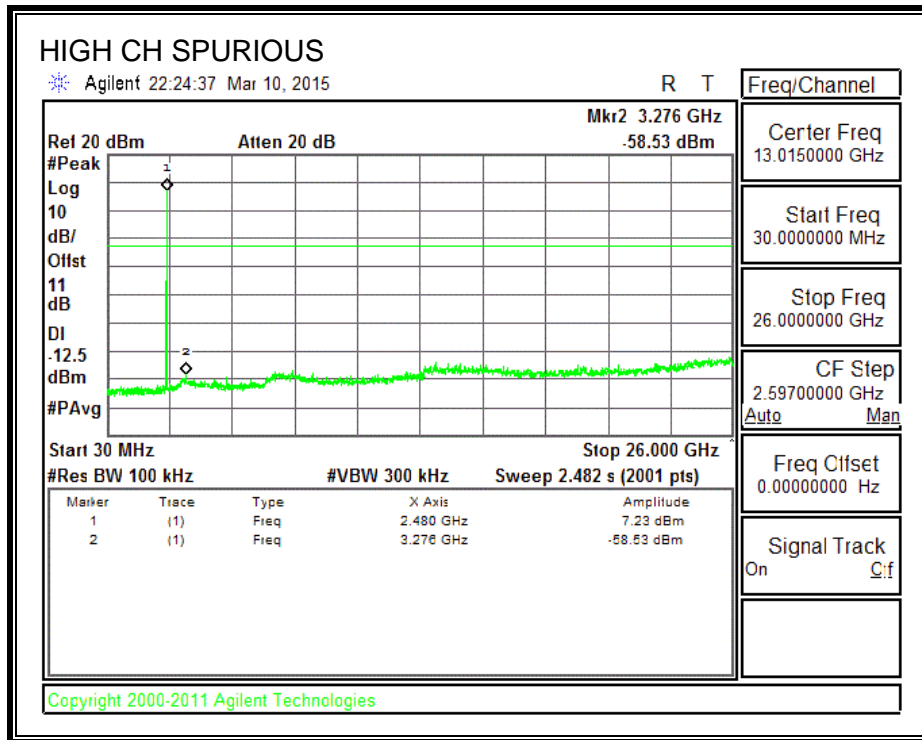
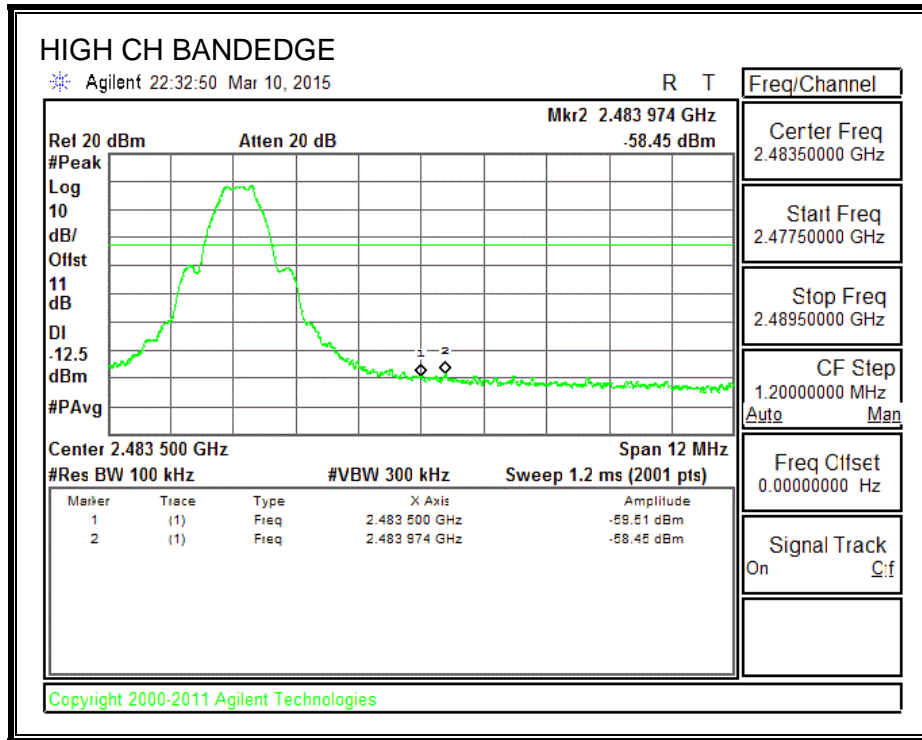

## 8.1. ANTENNA D

### 8.1.1. 6 dB BANDWIDTH

#### LIMITS

FCC §15.247 (a) (2)

IC RSS-247 (5.2) (1)

The minimum 6 dB bandwidth shall be at least 500 kHz.

#### RESULTS

Channel	Frequency (MHz)	6 dB Bandwidth (MHz)	Minimum Limit (MHz)
Low	2402	0.7238	0.5
Middle	2440	0.7122	0.5
High	2480	0.7278	0.5



**6 dB BANDWIDTH**

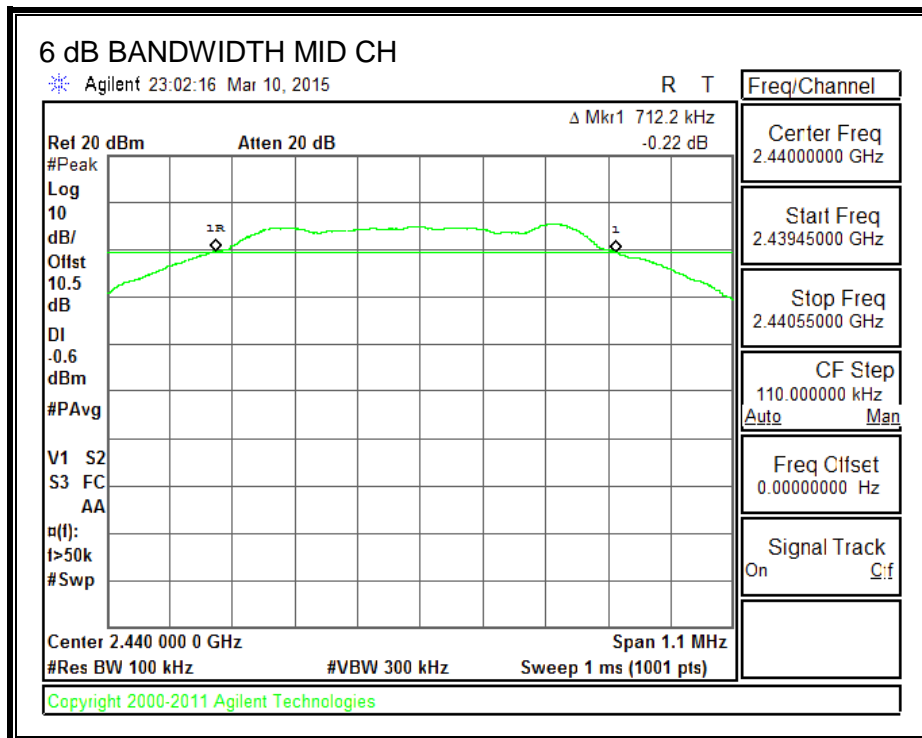
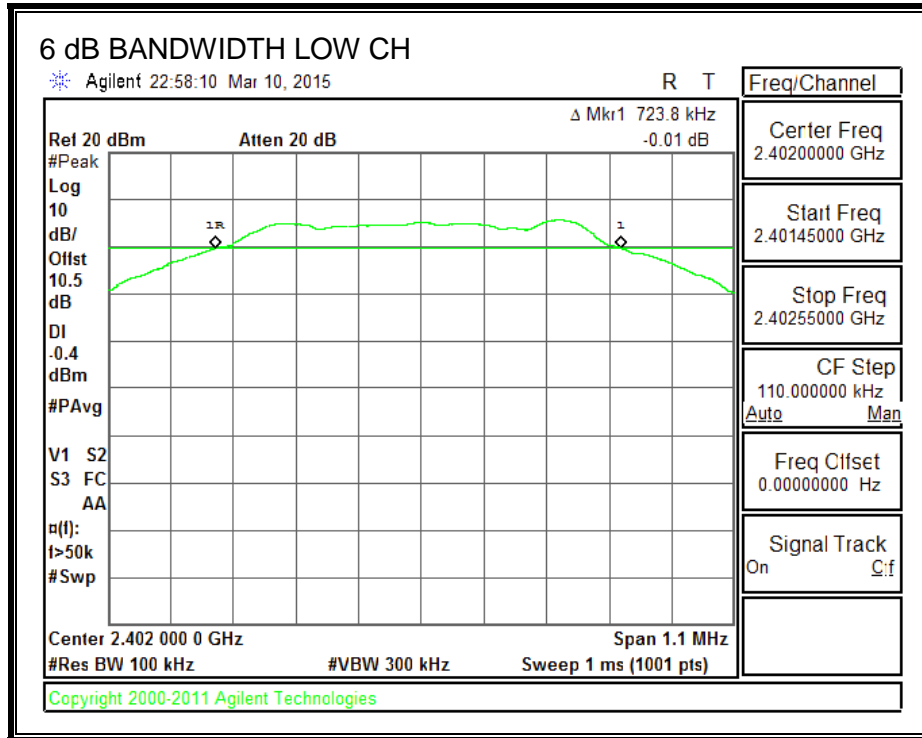

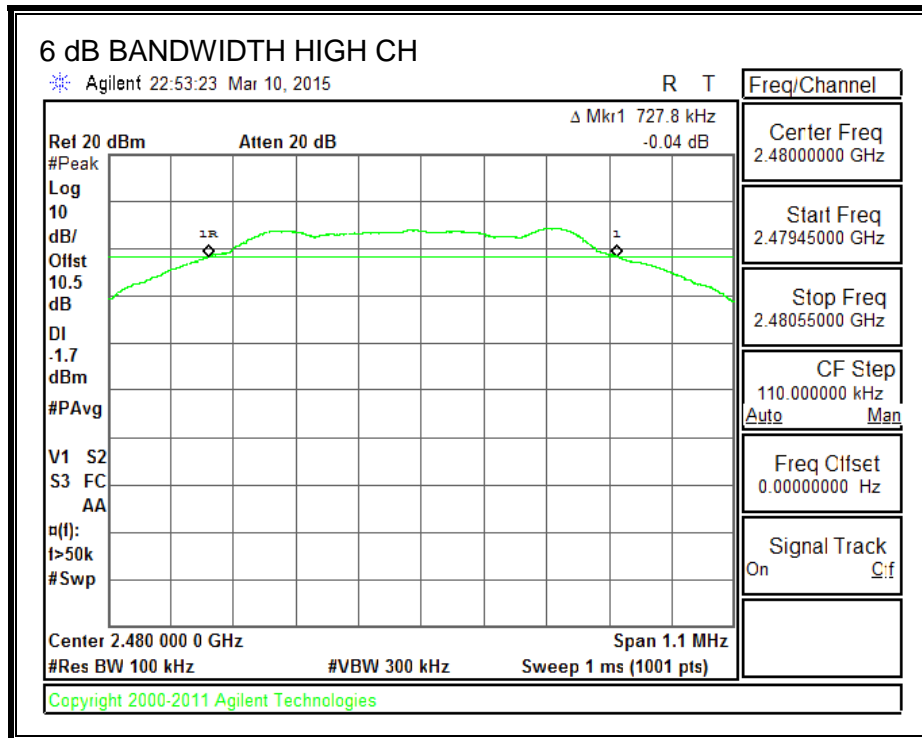

### 8.1.2. 99% BANDWIDTH

#### LIMITS

None; for reporting purposes only.

#### TEST PROCEDURE

The transmitter output is connected to the spectrum analyzer. The RBW is set to 1% to 3% of the 99 % bandwidth and to 1% of the span. The VBW is set to 3 times the RBW. The sweep time is coupled. The spectrum analyzer internal 99% bandwidth function is utilized.

#### RESULTS

Channel	Frequency (MHz)	99% Bandwidth (MHz)
Low	2402	1.0759
Middle	2440	1.0823
High	2480	1.0604

**99% BANDWIDTH**

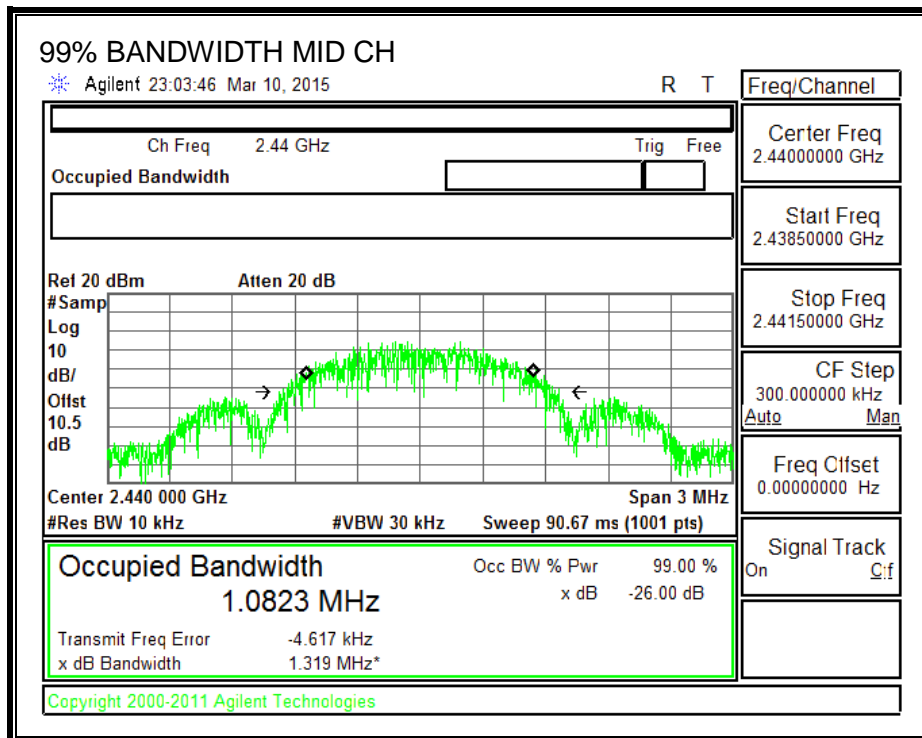
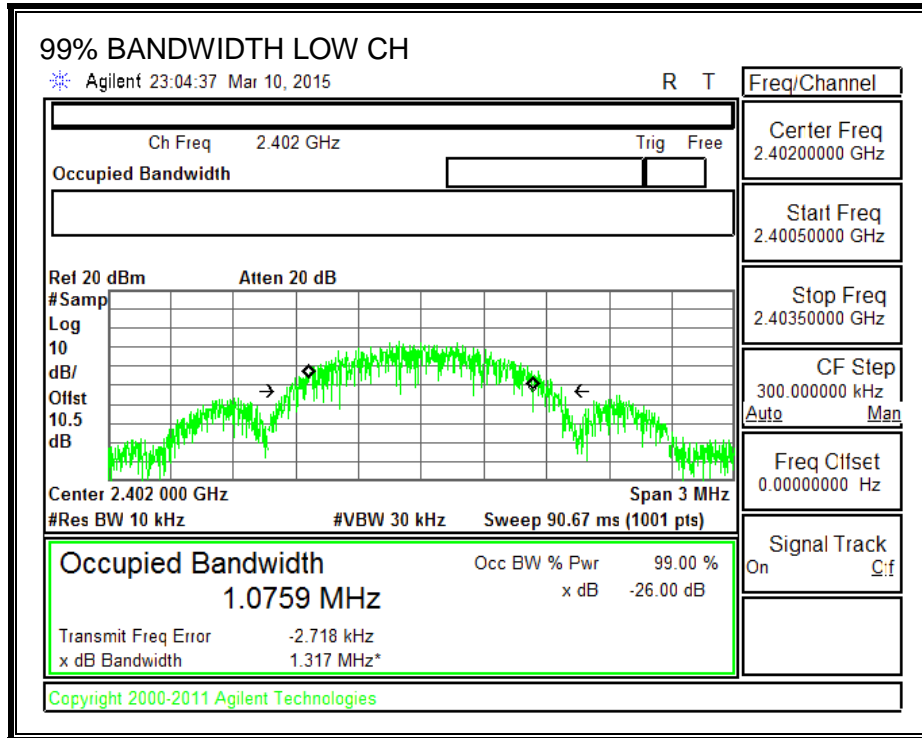

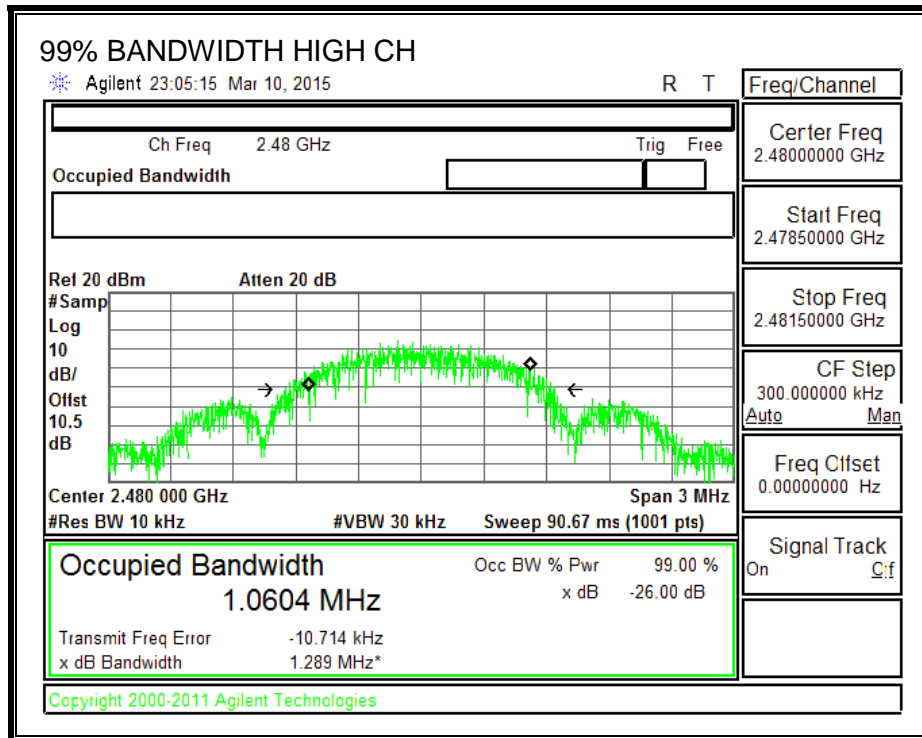

### 8.1.3. OUTPUT POWER

#### LIMITS

FCC §15.247 (b)

IC RSS-247 (5.4) (4)

The maximum antenna gain is less than or equal to 6 dBi, therefore the limit is 30 dBm.

#### TEST PROCEDURE

The transmitter output is connected to a wideband peak and average power meter.

#### RESULTS

Channel	Frequency (MHz)	Peak Power Reading (dBm)	Limit (dBm)	Margin (dB)
Low	2402	6.480	30	-23.520
Middle	2440	6.310	30	-23.690
High	2480	6.640	30	-23.360

### 8.1.4. AVERAGE POWER

#### LIMITS

None; for reporting purposes only.

#### RESULTS

The cable assembly insertion loss of 10.5 dB (including 10 dB pad and 0.50 dB cable) was entered as an offset in the power meter to allow for direct reading of power.

Channel	Frequency (MHz)	Average Power (dBm)
Low	2402	6.31
Middle	2440	6.13
High	2480	6.48

### 8.1.5. POWER SPECTRAL DENSITY

#### LIMITS

FCC §15.247 (e)

IC RSS-247 (5.2) (2)

The power spectral density conducted from the transmitter to the antenna shall not be greater than 8 dBm in any 3 kHz band during any time interval of continuous transmission.

#### RESULTS

Channel	Frequency (MHz)	PSD (dBm)	Limit (dBm)	Margin (dB)
Low	2402	-10.19	8	-18.19
Middle	2440	-10.37	8	-18.37
High	2480	-9.99	8	-17.99



**POWER SPECTRAL DENSITY**

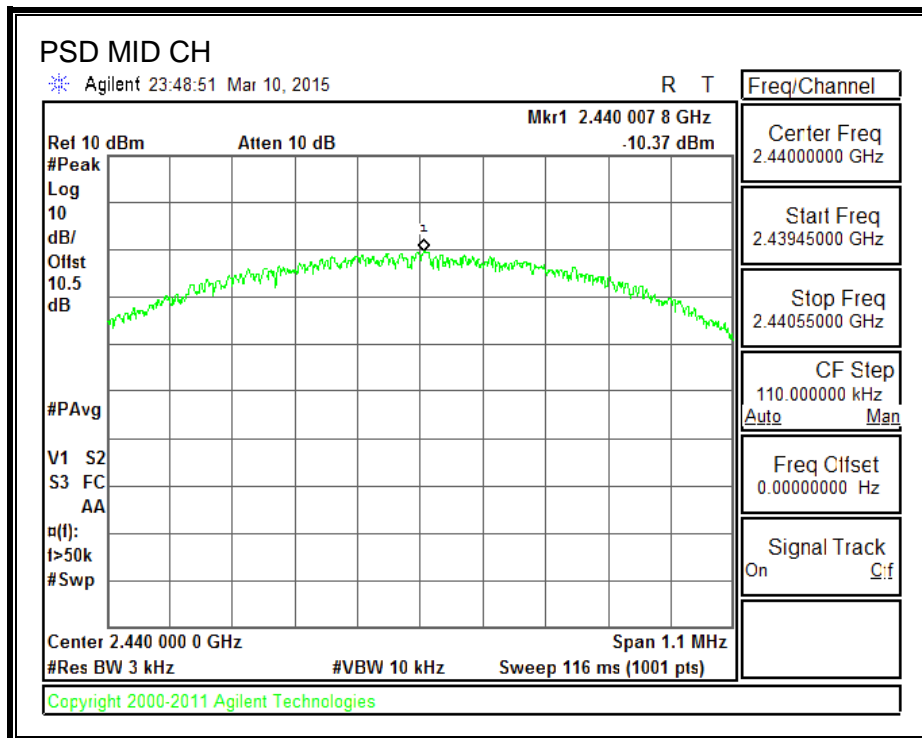
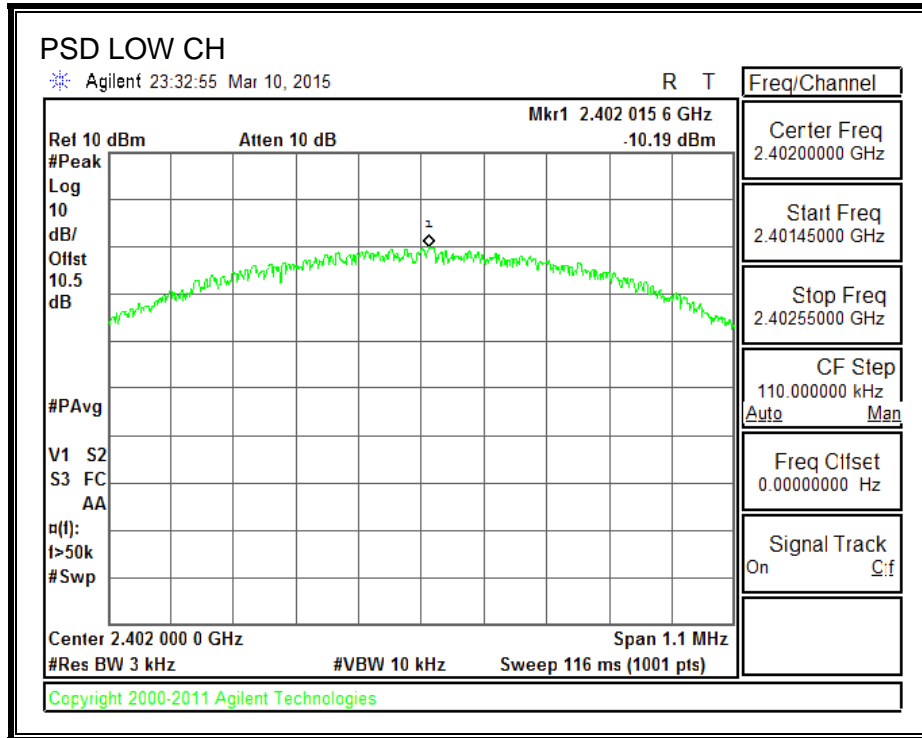

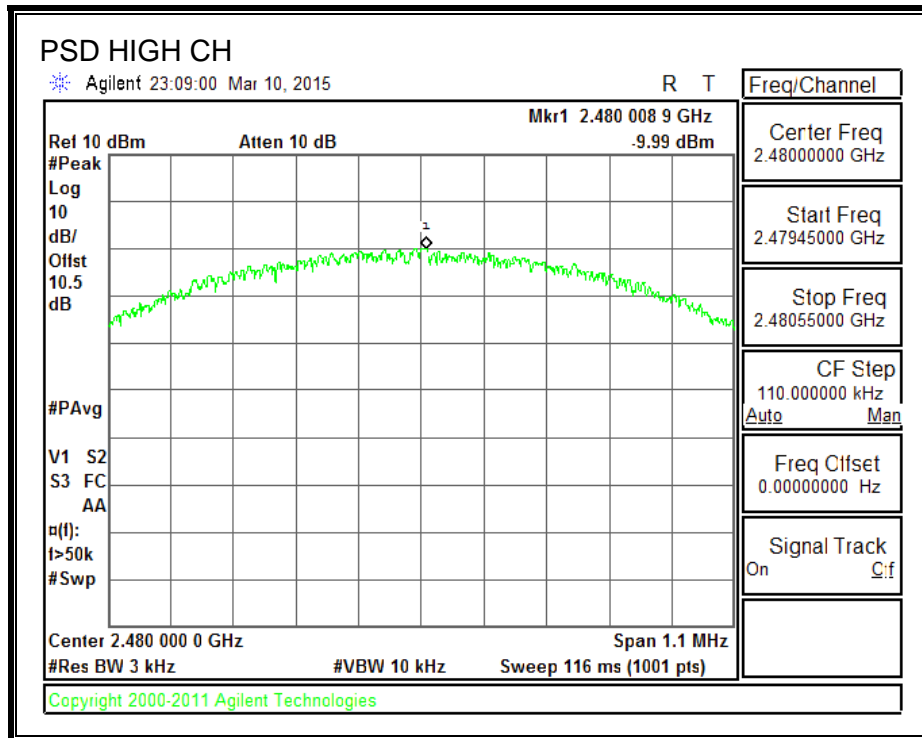

## **8.1.6. CONDUCTED SPURIOUS EMISSIONS**

### **LIMITS**

FCC §15.247 (d)

IC RSS-247 (5.5)

Output power was measured based on the use of a peak measurement, therefore the required attenuation is 20 dB.

### **TEST PROCEDURE**

The transmitter output is connected to a spectrum analyzer. The resolution bandwidth is set to 100 kHz. The video bandwidth is set to 300 kHz.

The spectrum from 30 MHz to 26 GHz is investigated with the transmitter set to the lowest, middle, and highest channels.

### **RESULTS**

**SPURIOUS EMISSIONS, LOW CHANNEL**

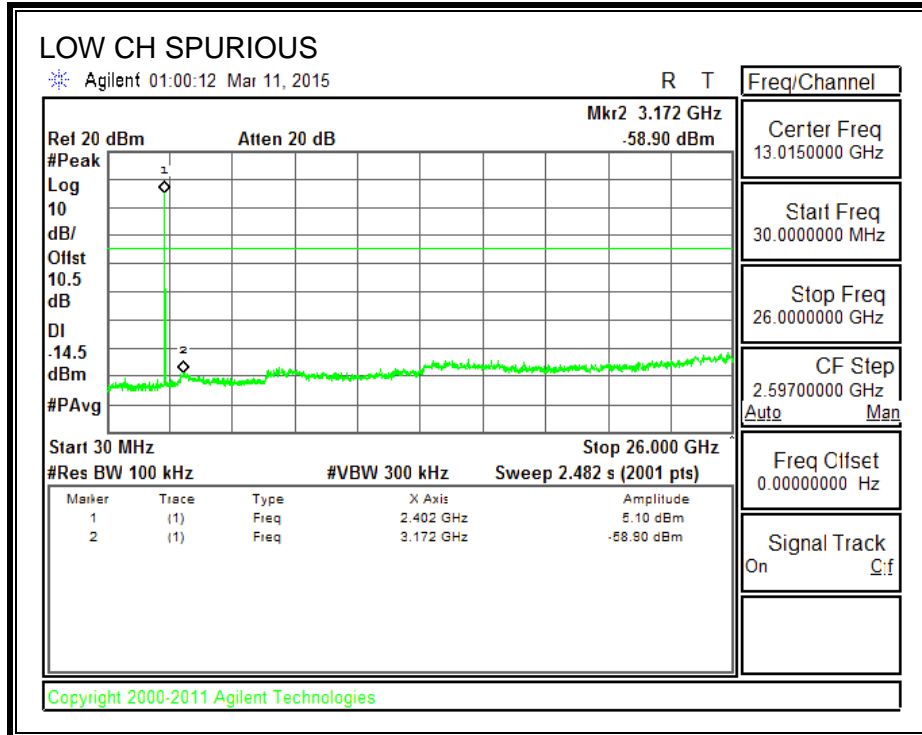
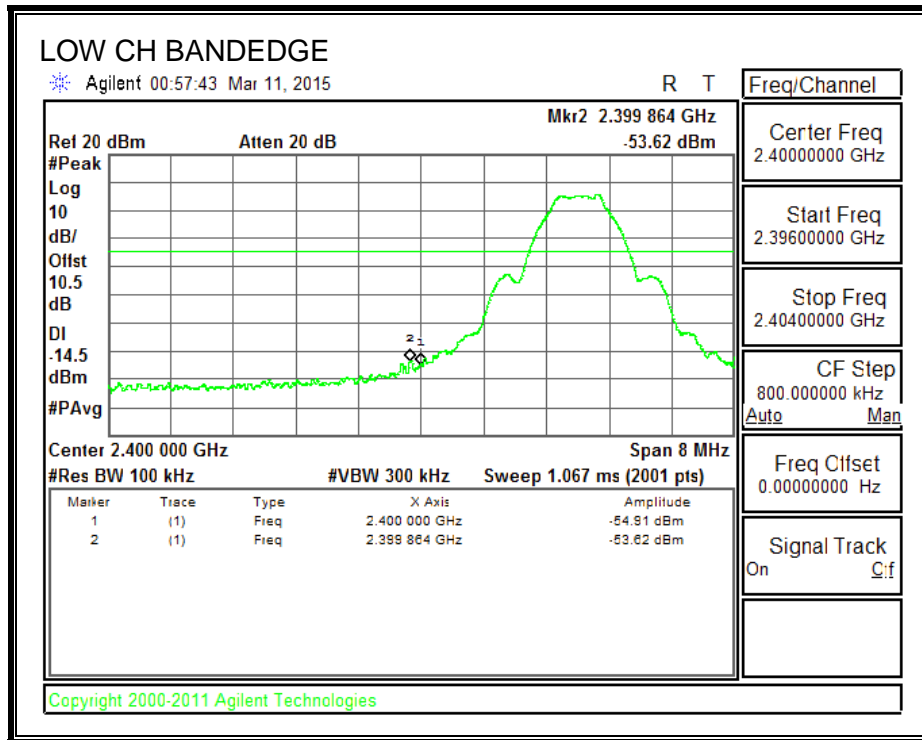

**SPURIOUS EMISSIONS, HIGH CHANNEL REFERENCE**

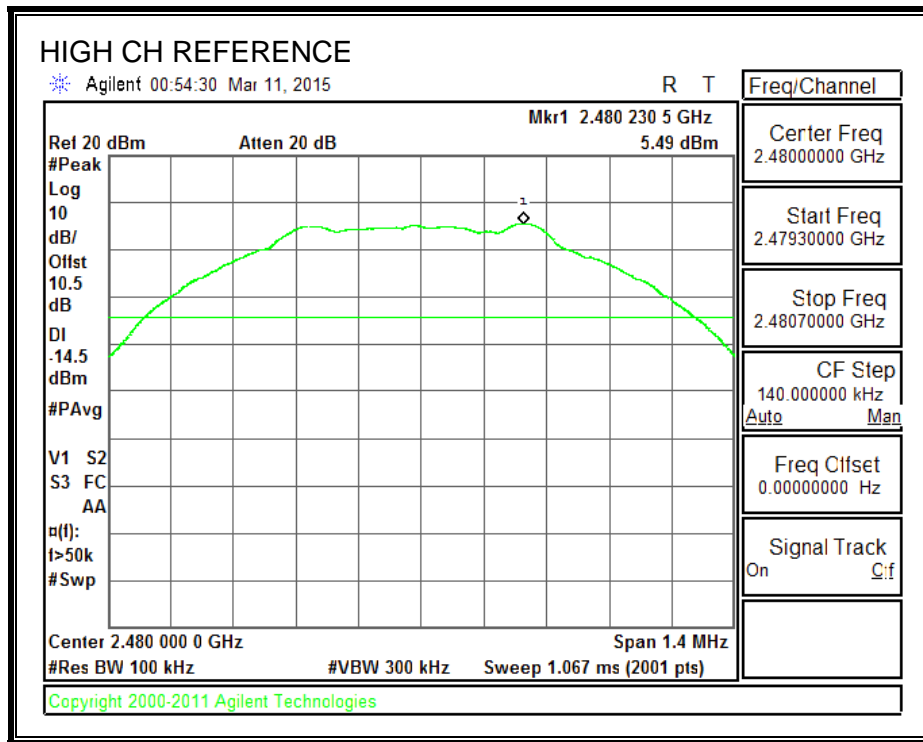

**SPURIOUS EMISSIONS, MID CHANNEL**

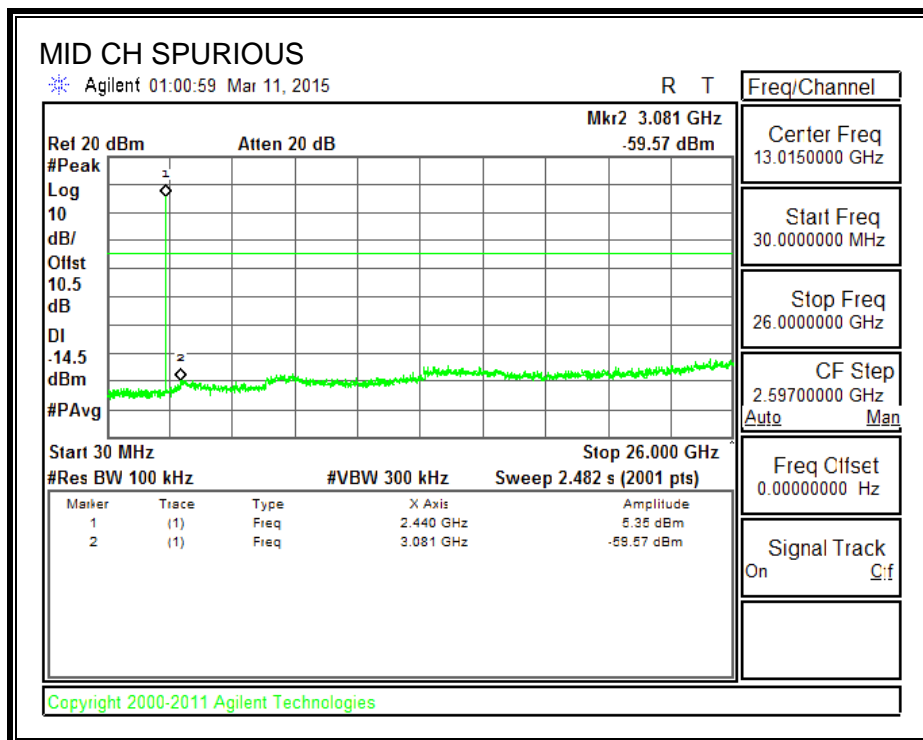

**SPURIOUS EMISSIONS, HIGH CHANNEL**

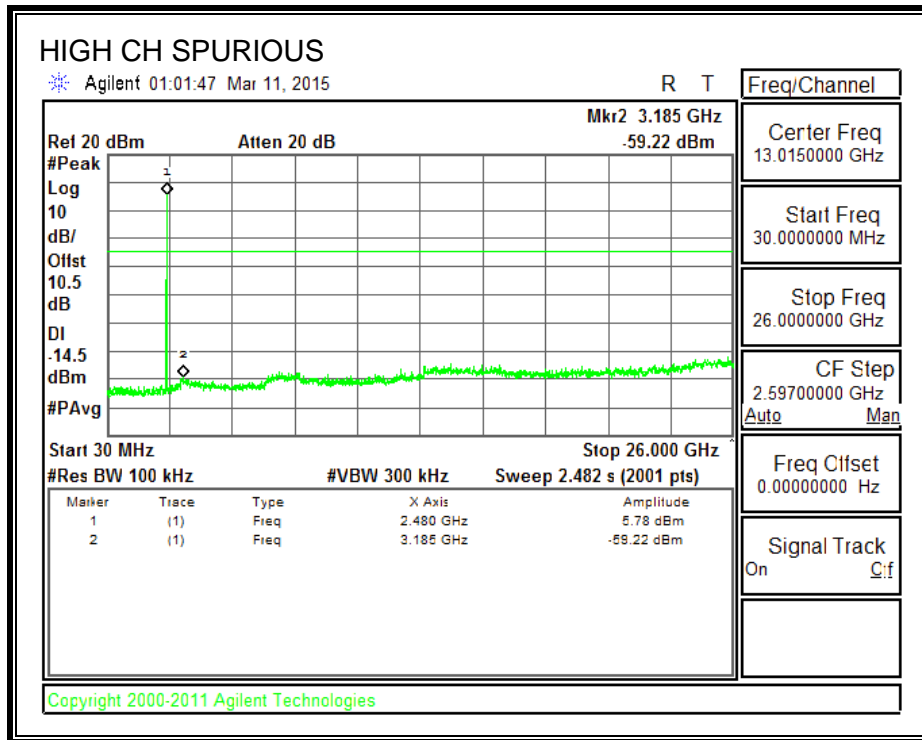
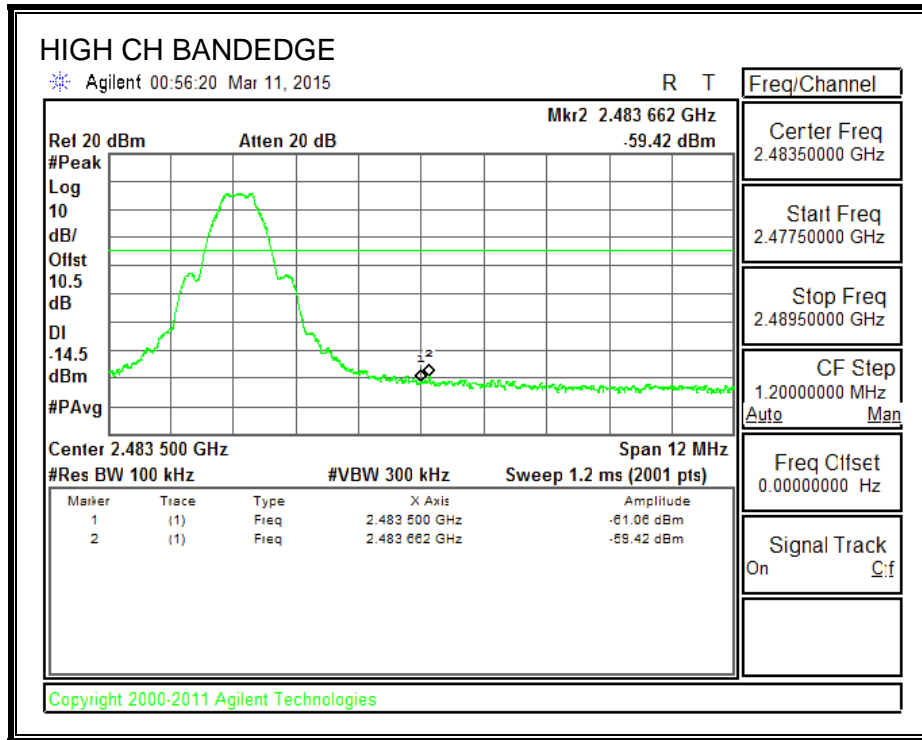

## 9. RADIATED TEST RESULTS

### 9.1. LIMITS AND PROCEDURE

#### LIMITS

FCC §15.205 and §15.209

IC RSS-GEN, Section 8.9 and 8.10.

Frequency Range (MHz)	Field Strength Limit (uV/m) at 3 m	Field Strength Limit (dBuV/m) at 3 m
30 - 88	100	40
88 - 216	150	43.5
216 - 960	200	46
Above 960	500	54

#### TEST PROCEDURE

The EUT is placed on a non-conducting table 80 cm above the ground plane. The antenna to EUT distance is 3 meters. The EUT is configured in accordance with ANSI C63.4. The EUT is set to transmit in a continuous mode.

For measurements below 1 GHz the resolution bandwidth is set to 100 kHz for peak detection measurements or 120 kHz for quasi-peak detection measurements. Peak detection is used unless otherwise noted as quasi-peak.

For measurements above 1 GHz the resolution bandwidth is set to 1 MHz, then the video bandwidth is set to 3 MHz for peak measurements and as applicable for average measurements.

For 2.4 GHz band, the spectrum from 30 MHz to 26 GHz is investigated with the transmitter set to the lowest, middle, and highest channels in the 2.4 GHz band.

The frequency range of interest is monitored at a fixed antenna height and EUT azimuth. The EUT is rotated through 360 degrees to maximize emissions received. The antenna is scanned from 1 to 4 meters above the ground plane to further maximize the emission. Measurements are made with the antenna polarized in both the vertical and the horizontal positions.

## 9.2. TRANSMITTER ABOVE 1 GHz BLUETOOTH LOW ENERGY

### 9.2.1. MODE IN THE 2.4 GHz BAND ANTENNA B

#### RESTRICTED BANDEDGE (LOW CHANNEL, HORIZONTAL)

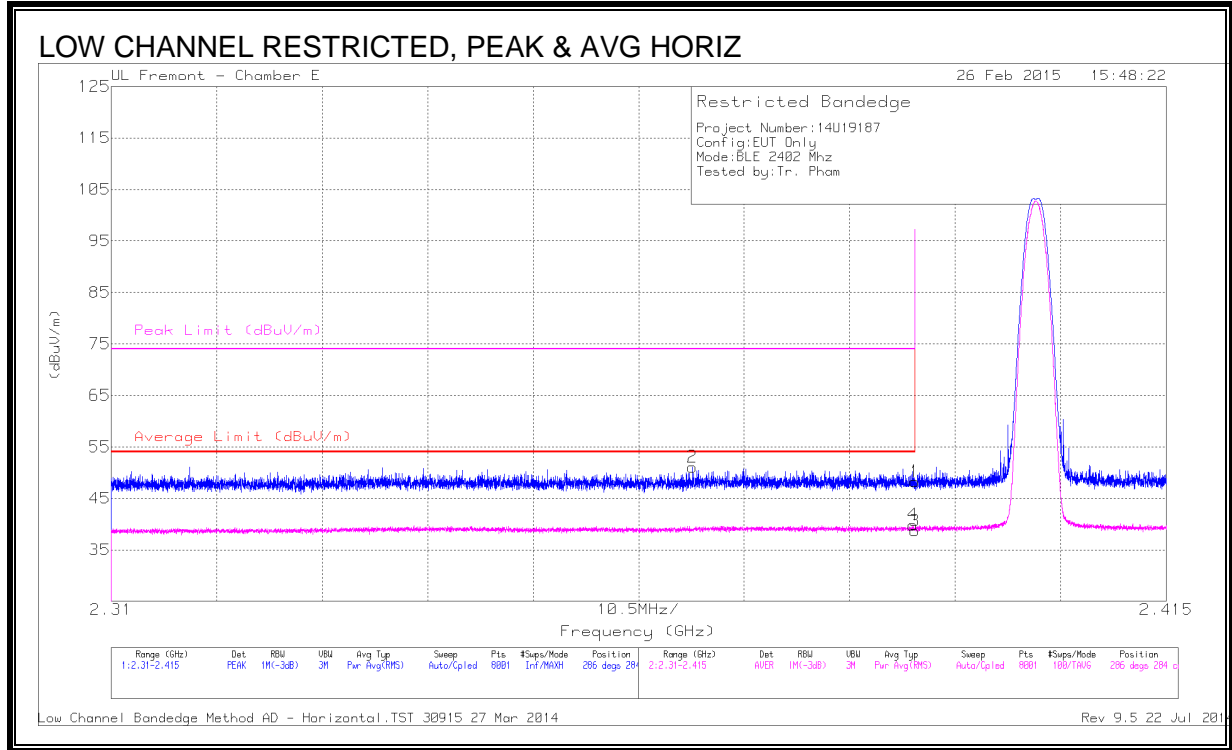

#### DATA

Marker	Frequency (GHz)	Meter Reading (dBuV)	Det	AF T346 (dB/m)	Amp/Cbl/Ftr/Pad (dB)	Corrected Reading (dBuV/m)	Average Limit (dBuV/m)	Margin (dB)	Peak Limit (dBuV/m)	PK Margin (dB)	Azimuth (Degs)	Height (cm)	Polarity
2	* 2.368	43.81	PK	32	-24.7	51.11	-	-	74	-22.89	286	284	H
1	* 2.39	40.87	PK	32.1	-24.7	48.27	-	-	74	-25.73	286	284	H
3	* 2.39	31.32	RMS	32.1	-24.7	38.72	54	-15.28	-	-	286	284	H
4	* 2.39	32.46	RMS	32.1	-24.7	39.86	54	-14.14	-	-	286	284	H

\* - indicates frequency in CFR 47, Part 15 and Industry Canada RSS-Restricted Band.

PK - Peak detector

RMS - RMS detection



**RESTRICTED BANDEDGE (LOW CHANNEL, VERTICAL)**

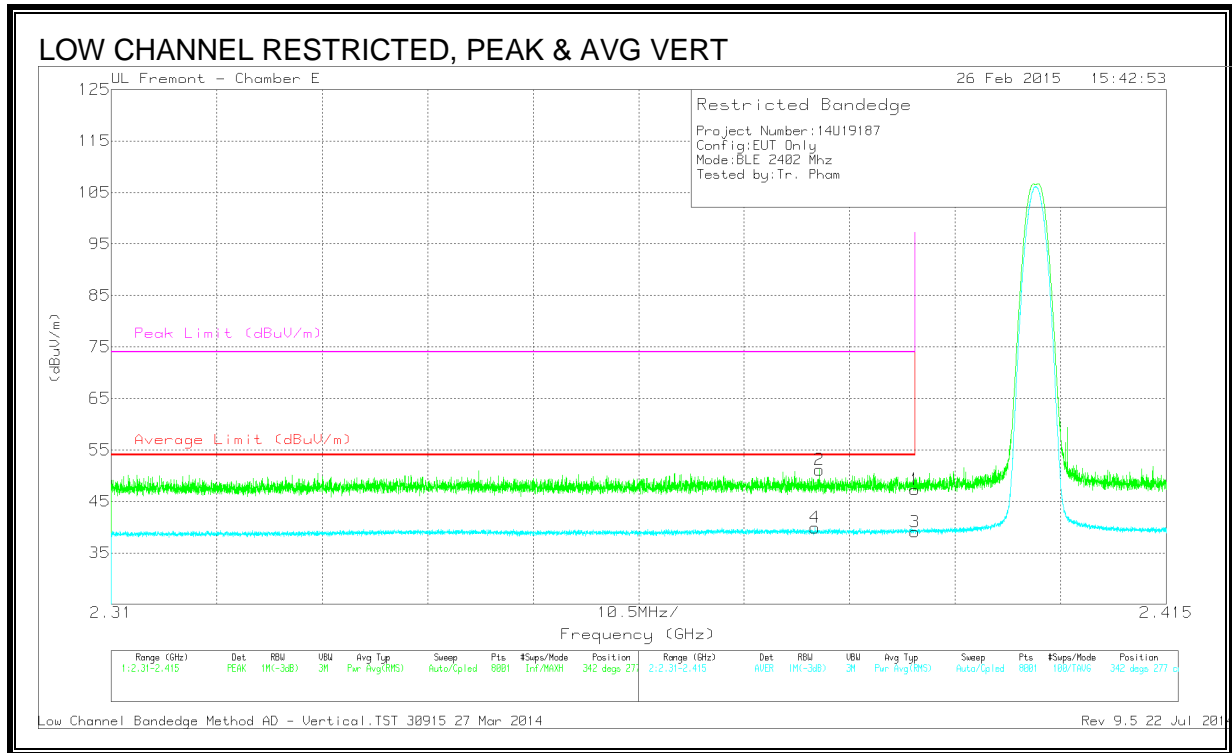

**DATA**

Marker	Frequency (GHz)	Meter Reading (dBuV)	Det	AF T346 (dB/m)	Amp/Cbl/ Ftr/Pad (dB)	Corrected Reading (dBuV/m)	Average Limit (dBuV/m)	Margin (dB)	Peak Limit (dBuV/m)	PK Margin (dB)	Azimuth (Degs)	Height (cm)	Polarity
1	* 2.39	39.89	PK	32.1	-24.7	47.29	-	-	74	-26.71	342	277	V
2	* 2.38	43.73	PK	32	-24.6	51.13	-	-	74	-22.87	342	277	V
3	* 2.39	31.69	RMS	32.1	-24.7	39.09	54	-14.91	-	-	342	277	V
4	* 2.38	32.49	RMS	32	-24.6	39.89	54	-14.11	-	-	342	277	V

\* - indicates frequency in CFR 47, Part 15 and Industry Canada RSS-Restricted Band.

PK - Peak detector

RMS - RMS detection

**RESTRICTED BANDEDGE (HIGH CHANNEL, HORIZONTAL)**

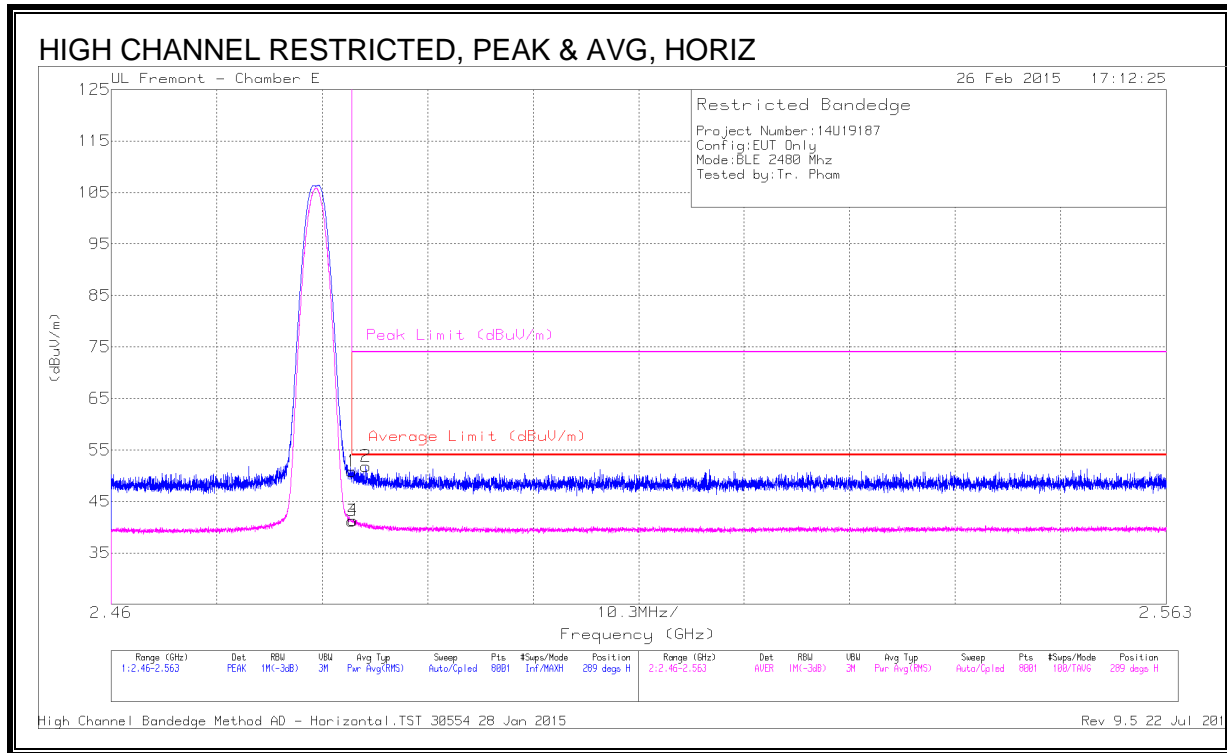

**DATA**

Marker	Frequency (GHz)	Meter Reading (dBuV)	Det	AF T346 (dB/m)	Amp/Cbl/Ftr/Pad (dB)	Corrected Reading (dBuV/m)	Average Limit (dBuV/m)	Margin (dB)	Peak Limit (dBuV/m)	PK Margin (dB)	Azimuth (Degs)	Height (cm)	Polarity
1	* 2.484	42.94	PK	32.2	-24.3	50.84	-	-	74	-23.16	289	265	H
3	* 2.484	33.33	RMS	32.2	-24.3	41.23	54	-12.77	-	-	289	265	H
4	* 2.484	33.4	RMS	32.2	-24.3	41.3	54	-12.7	-	-	289	265	H
2	* 2.485	43.94	PK	32.2	-24.3	51.84	-	-	74	-22.16	289	265	H

\* - indicates frequency in CFR 47, Part 15 and Industry Canada RSS-Restricted Band.

PK - Peak detector

RMS - RMS detection

**RESTRICTED BANDEDGE (HIGH CHANNEL, VERTICAL)**

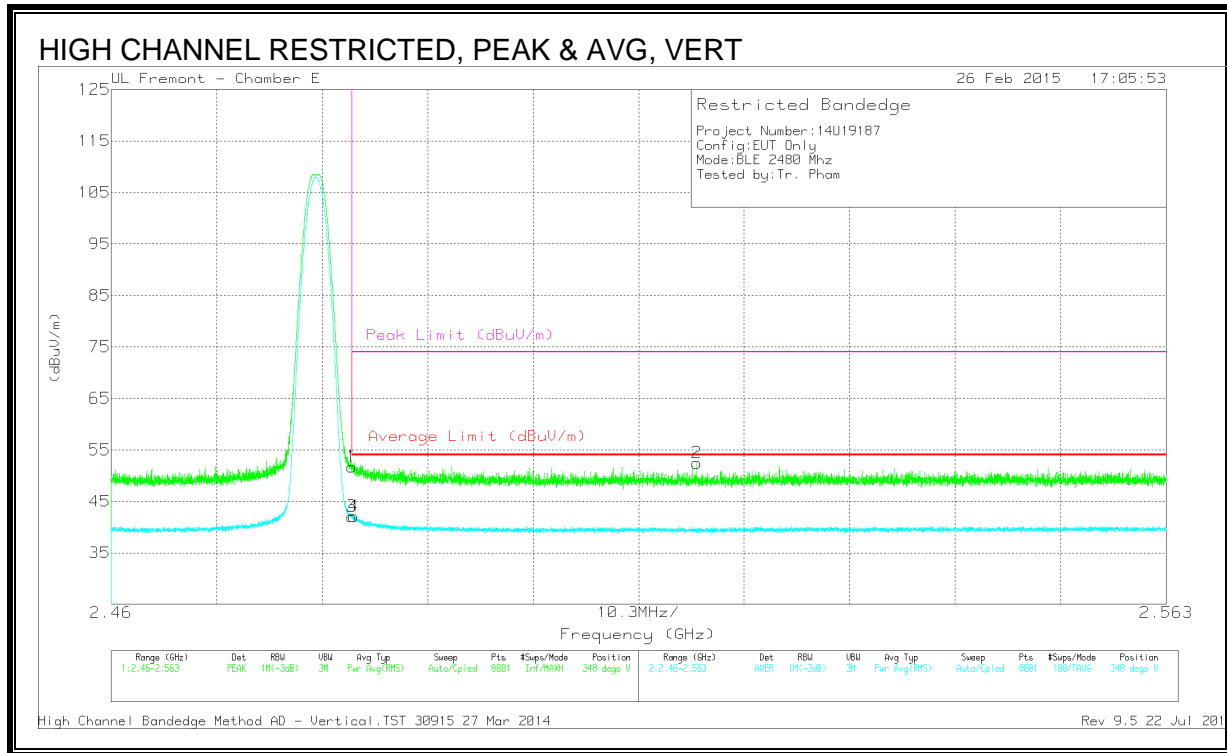

**DATA**

Marker	Frequency (GHz)	Meter Reading (dBuV)	Det	AF T346 (dB/m)	Amp/Cbl/Ftr/Pad (dB)	Corrected Reading (dBuV/m)	Average Limit (dBuV/m)	Margin (dB)	Peak Limit (dBuV/m)	PK Margin (dB)	Azimuth (Degs)	Height (cm)	Polarity
1	* 2.484	43.81	PK	32.2	-24.3	51.71	-	-	74	-22.29	348	260	V
3	* 2.484	34.17	RMS	32.2	-24.3	42.07	54	-11.93	-	-	348	260	V
4	* 2.484	34.2	RMS	32.2	-24.3	42.1	54	-11.9	-	-	348	260	V
2	2.517	44.48	PK	32.2	-24.2	52.48	-	-	74	-21.52	348	260	V

\* - indicates frequency in CFR 47, Part 15 and Industry Canada RSS-Restricted Band.

PK - Peak detector

RMS - RMS detection

**LOW CHANNEL HARMONICS AND SPURIOUS EMISSIONS**

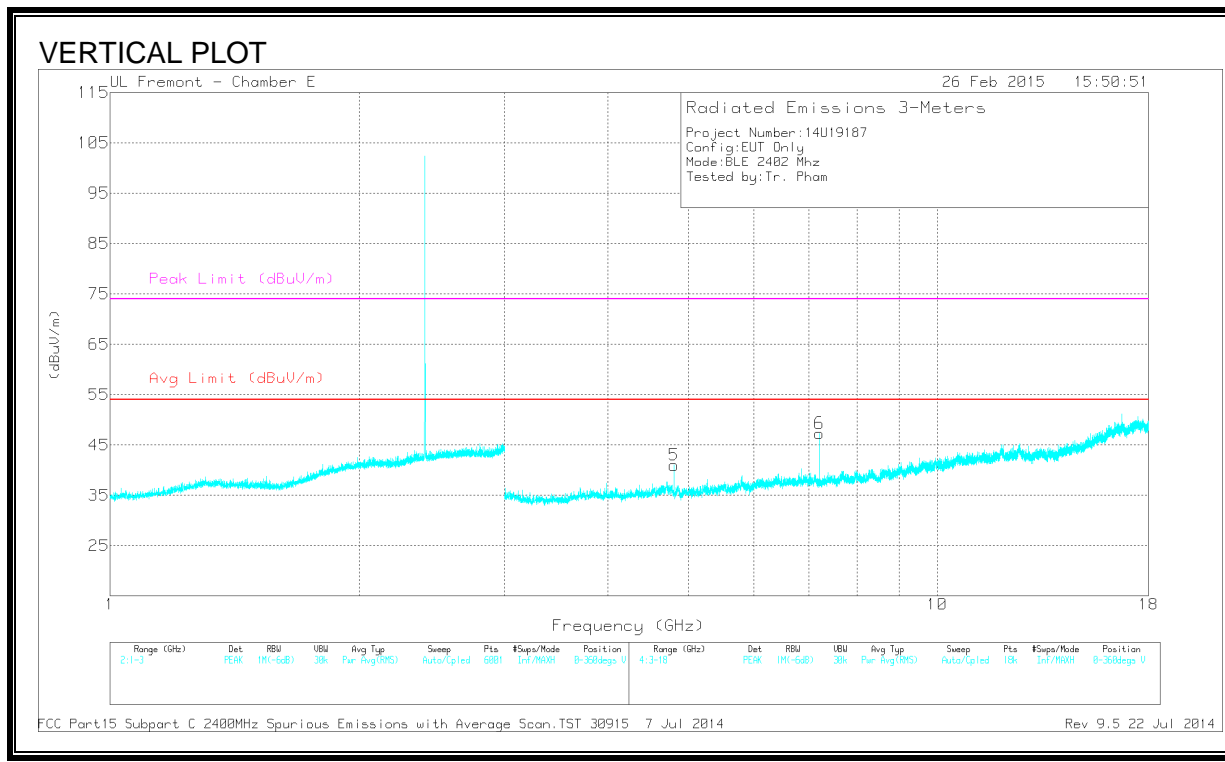
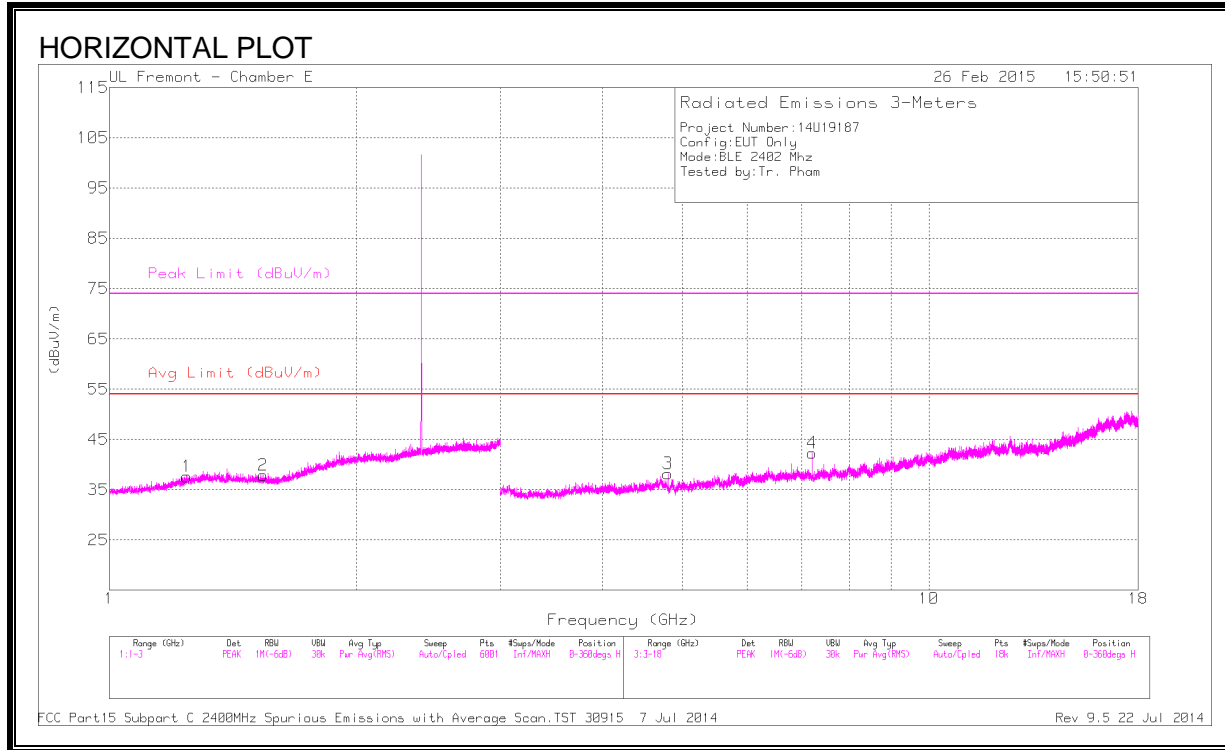

**DATA**

Markers	Frequency (GHz)	Meter Reading (dBuV)	Det	AF T346 (dB/m)	Amp/Cbl/Filtr/Pad (dB)	Corrected Reading (dBuV/m)	Avg Limit (dBuV/m)	Margin (dB)	Peak Limit (dBuV/m)	PK Margin (dB)	Azimuth (Degs)	Height (cm)	Polarity
1	* 1.243	44.59	PK2	28.5	-27.3	45.79	-	-	74	-28.21	360	101	H
	* 1.243	32.94	MAv1	28.5	-27.3	34.14	54	-19.86	-	-	360	101	H
2	* 1.541	43.68	PK2	28.1	-26.3	45.48	-	-	74	-28.52	360	101	H
	* 1.539	32.45	MAv1	28.1	-26.3	34.25	54	-19.75	-	-	360	101	H
3	* 4.804	44.9	PK2	34.1	-30.9	48.1	-	-	74	-25.9	274	302	H
	* 4.804	35.45	MAv1	34.1	-30.9	38.65	54	-15.35	-	-	274	302	H
5	* 4.804	45.77	PK2	34.1	-30.9	48.97	-	-	74	-25.03	321	186	V
	* 4.804	37.88	MAv1	34.1	-30.9	41.08	54	-12.92	-	-	321	186	V
6	7.205	28.79	MAv1	35.5	-28.4	35.89	-	-	-	-	321	186	V
	7.206	39.61	PK2	35.5	-28.4	46.71	-	-	-	-	274	302	H
4	7.206	39.52	PK2	35.5	-28.4	46.62	-	-	-	-	321	186	V
	7.207	28.52	MAv1	35.5	-28.4	35.62	-	-	-	-	274	302	H

\* - indicates frequency in CFR 47, Part 15 and Industry Canada RSS-Restricted Band.

PK2 - KDB558074 Method: Maximum Peak

MAv1 - KDB558074 Option 1 Maximum RMS Average

**MID CHANNEL HARMONICS AND SPURIOUS EMISSIONS**

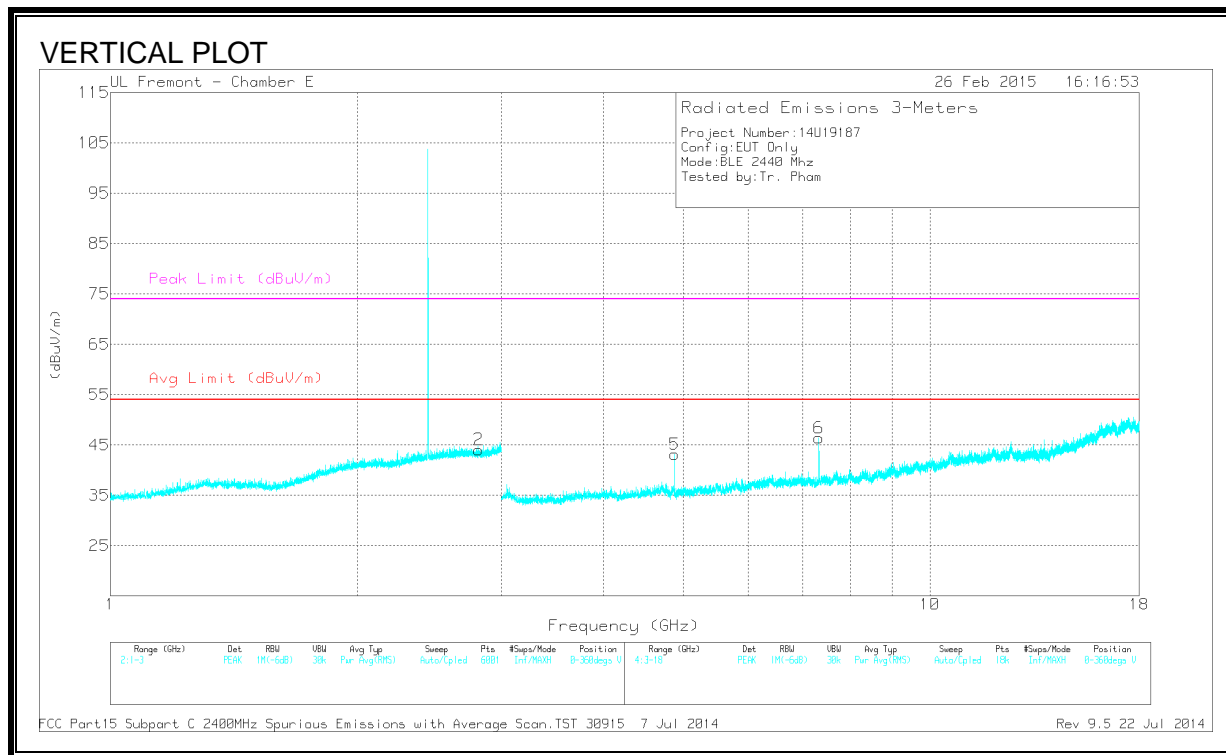
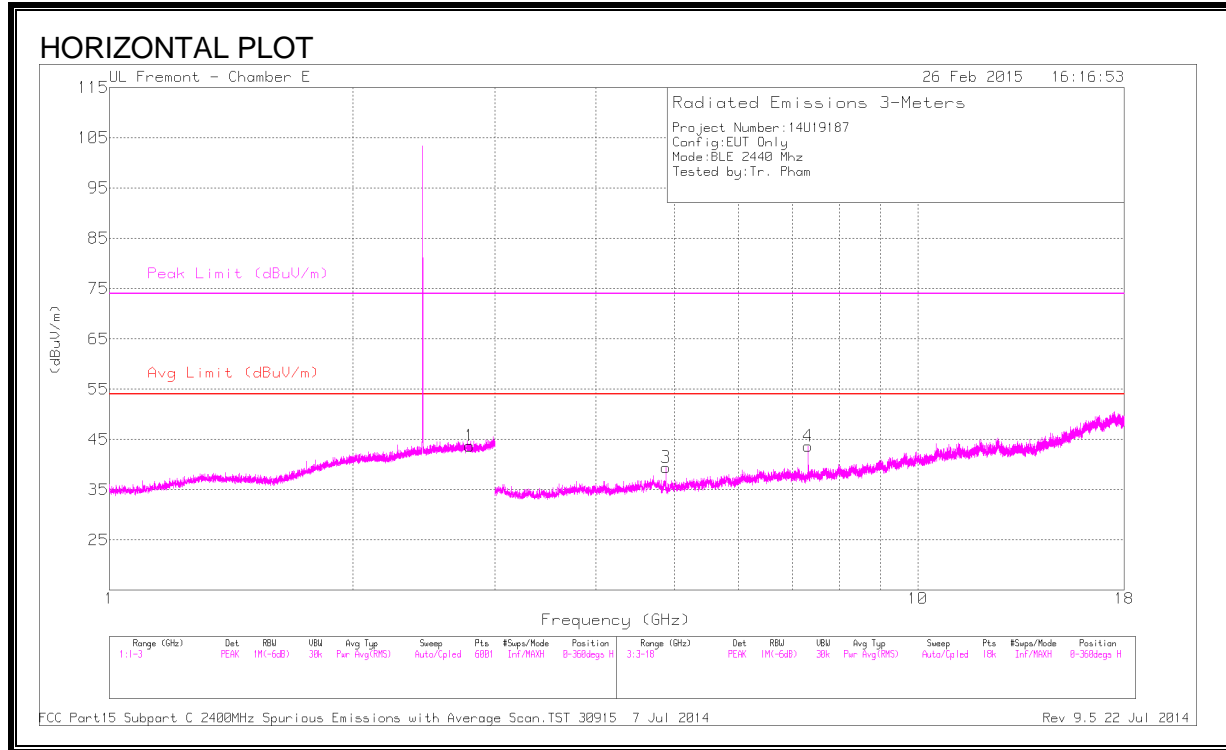

**DATA**

Markers	Frequency (GHz)	Meter Reading (dBuV)	Det	AF T346 (dB/m)	Amp/Cbl/ Fitr/Pad (dB)	Corrected Reading (dBuV/m)	Avg Limit (dBuV/m)	Margin (dB)	Peak Limit (dBuV/m)	PK Margin (dB)	Azimuth (Degs)	Height (cm)	Polarity
1	* 2.791	44.69	PK2	32.4	-24.1	52.99	-	-	74	-21.01	360	101	H
	* 2.791	32.06	MAv1	32.4	-24.1	40.36	54	-13.64	-	-	360	101	H
2	* 2.814	43.65	PK2	32.4	-24.1	51.95	-	-	74	-22.05	360	101	V
	* 2.816	32.08	MAv1	32.4	-24.1	40.38	54	-13.62	-	-	360	101	V
3	* 4.879	45.14	PK2	34.1	-31	48.24	-	-	74	-25.76	99	264	H
	* 4.88	36.69	MAv1	34.1	-31	39.79	54	-14.21	-	-	99	264	H
4	* 7.32	42.97	PK2	35.5	-27.7	50.77	-	-	74	-23.23	335	210	H
	* 7.321	34.65	MAv1	35.5	-27.7	42.45	54	-11.55	-	-	335	210	H
5	* 4.879	46.92	PK2	34.1	-31	50.02	-	-	74	-23.98	138	196	V
	* 4.88	39.87	MAv1	34.1	-31	42.97	54	-11.03	-	-	138	196	V
6	* 7.32	44.86	PK2	35.5	-27.7	52.66	-	-	74	-21.34	79	207	V
	* 7.321	37.21	MAv1	35.5	-27.7	45.01	54	-8.99	-	-	79	207	V

\* - indicates frequency in CFR 47, Part 15 and Industry Canada RSS-Restricted Band.

PK2 - KDB558074 Method: Maximum Peak

MAv1 - KDB558074 Option 1 Maximum RMS Average

**HIGH CHANNEL HARMONICS AND SPURIOUS EMISSIONS**

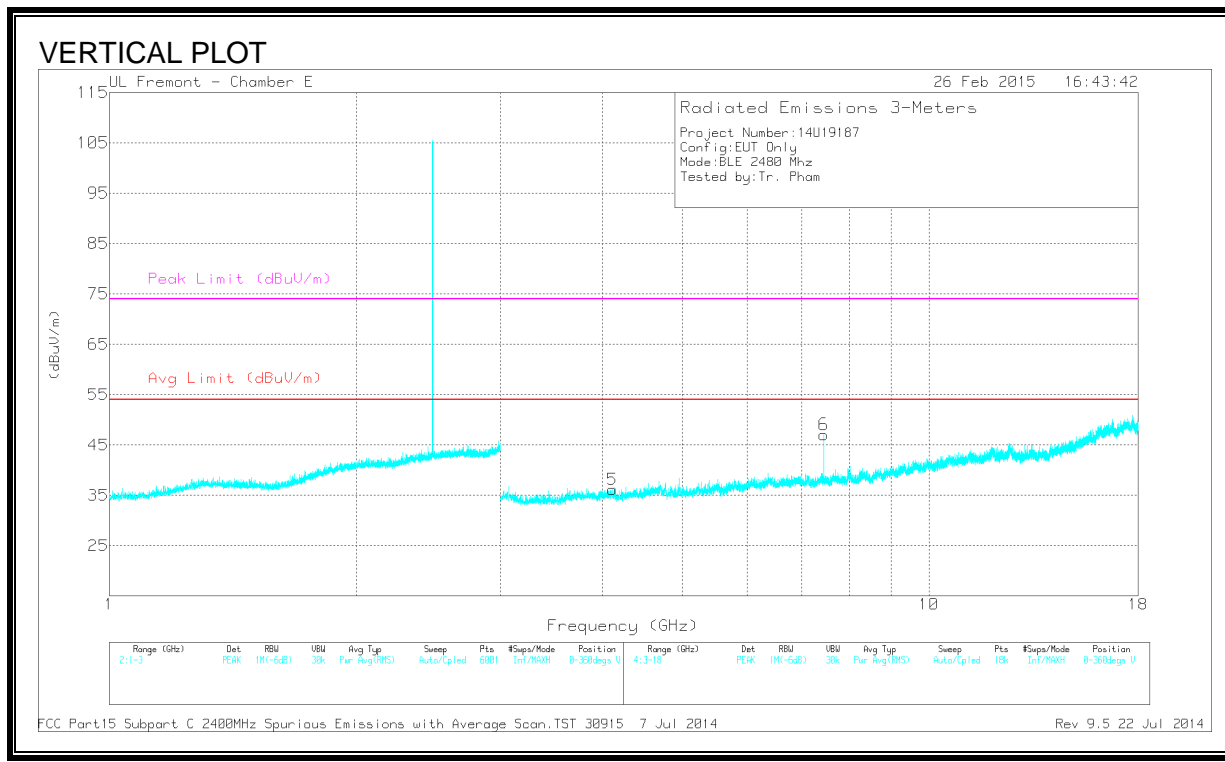
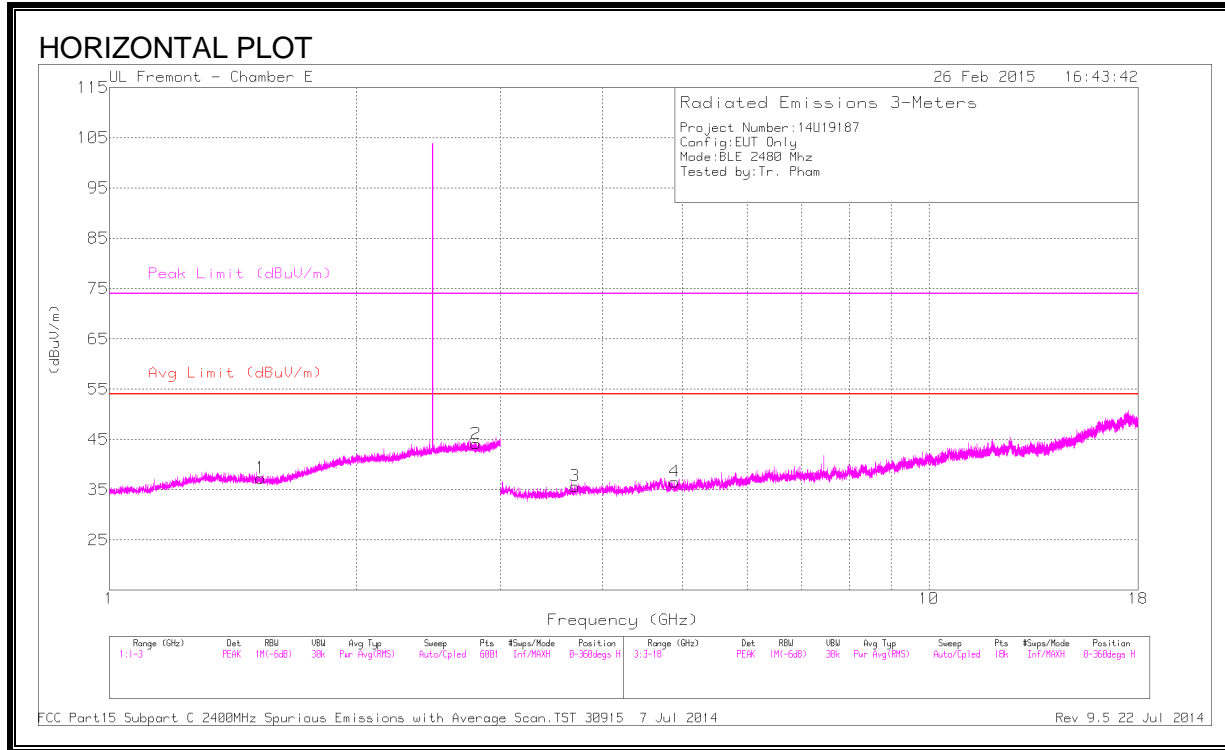



**DATA**

Markers	Frequency (GHz)	Meter Reading (dBuV)	Det	AF T346 (dB/m)	Amp/Cbl/ Fitr/Pad (dB)	Corrected Reading (dBuV/m)	Avg Limit (dBuV/m)	Margin (dB)	Peak Limit (dBuV/m)	PK Margin (dB)	Azimuth (Degs)	Height (cm)	Polarity
1	* 1.53	43.61	PK2	28.1	-26.4	45.31	-	-	74	-28.69	0	101	H
	* 1.53	32.37	MAv1	28.1	-26.4	34.07	54	-19.93	-	-	0	101	H
2	* 2.801	43.76	PK2	32.4	-24.1	52.06	-	-	74	-21.94	0	101	H
	* 2.802	32.08	MAv1	32.4	-24.1	40.38	54	-13.62	-	-	0	101	H
3	* 3.7	41.61	PK2	33.2	-30.6	44.21	-	-	74	-29.79	0	101	H
	* 3.7	29.98	MAv1	33.2	-30.6	32.58	54	-21.42	-	-	0	101	H
4	* 4.894	40.94	PK2	34.1	-30.7	44.34	-	-	74	-29.66	0	101	H
	* 4.894	29.86	MAv1	34.1	-30.7	33.26	54	-20.74	-	-	0	101	H
5	* 4.112	41.33	PK2	33.4	-30.6	44.13	-	-	74	-29.87	0	101	V
	* 4.112	30.09	MAv1	33.4	-30.6	32.89	54	-21.11	-	-	0	101	V
6	* 7.441	45.86	PK2	35.6	-28.2	53.26	-	-	74	-20.74	241	192	V
	* 7.441	38.52	MAv1	35.6	-28.2	45.92	54	-8.08	-	-	241	192	V

\* - indicates frequency in CFR 47, Part 15 and Industry Canada RSS-Restricted Band.

PK2 - KDB558074 Method: Maximum Peak

MAv1 - KDB558074 Option 1 Maximum RMS Average

### 9.2.2. MODE IN THE 2.4 GHz BAND ANTENNA D

#### RESTRICTED BANDEDGE (LOW CHANNEL, HORIZONTAL)

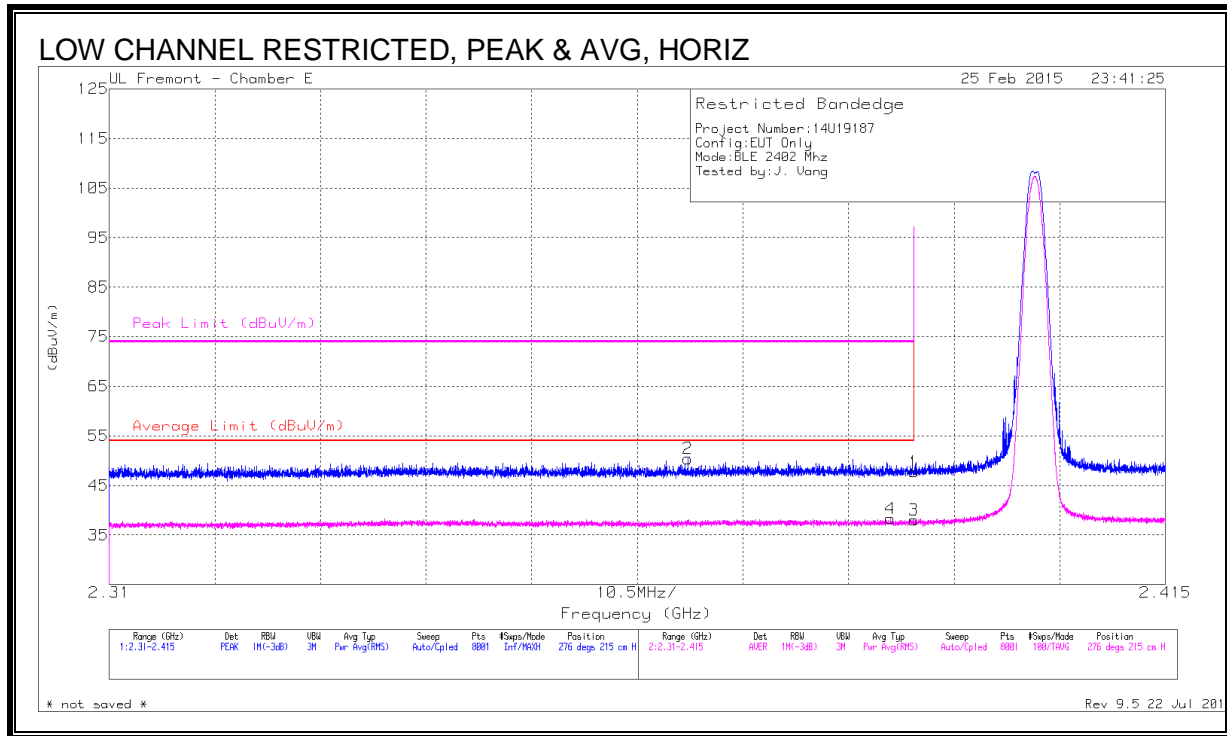

#### DATA

Marker	Frequency (GHz)	Meter Reading (dBuV)	Det	AF T346 (dB/m)	Amp/Cbl/Ftr/Pad (dB)	Corrected Reading (dBuV/m)	Average Limit (dBuV/m)	Margin (dB)	Peak Limit (dBuV/m)	PK Margin (dB)	Azimuth (Degs)	Height (cm)	Polarity
1	* 2.39	40.3	PK	32.1	-24.7	47.7	-	-	74	-26.3	276	215	H
2	* 2.368	43.11	PK	32	-24.7	50.41	-	-	74	-23.59	276	215	H
3	* 2.39	30.64	RMS	32.1	-24.7	38.04	54	-15.96	-	-	276	215	H
4	* 2.388	30.95	RMS	32.1	-24.7	38.35	54	-15.65	-	-	276	215	H

\* - indicates frequency in CFR 47, Part 15 and Industry Canada RSS-Restricted Band.

PK - Peak detector

RMS - RMS detection

**RESTRICTED BANDEDGE (LOW CHANNEL, VERTICAL)**

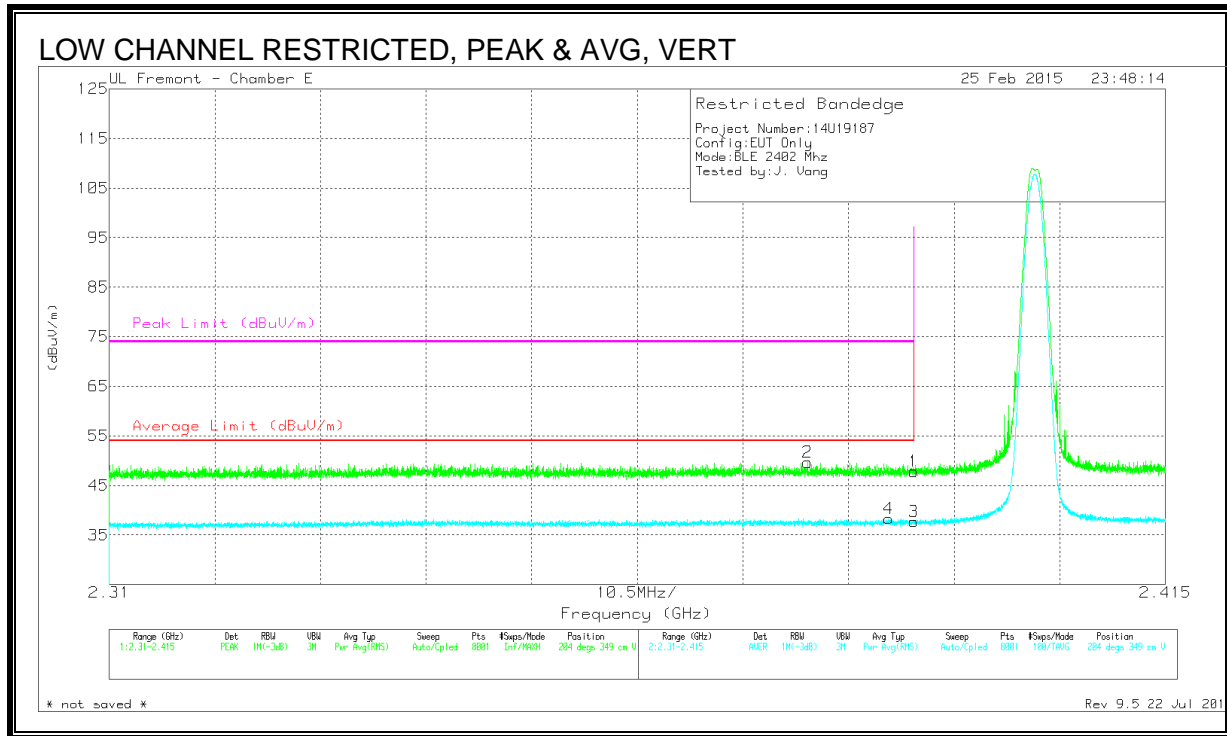

**DATA**

Marker	Frequency (GHz)	Meter Reading (dBuV)	Det	AF T346 (dB/m)	Amp/Cbl/ Ftr/Pad (dB)	Corrected Reading (dBuV/m)	Average Limit (dBuV/m)	Margin (dB)	Peak Limit (dBuV/m)	PK Margin (dB)	Azimuth (Degs)	Height (cm)	Polarity
2	* 2.379	42.24	PK	32	-24.6	49.64	-	-	74	-24.36	204	349	V
4	* 2.387	30.91	RMS	32.1	-24.7	38.31	54	-15.69	-	-	204	349	V
1	* 2.39	40.43	PK	32.1	-24.7	47.83	-	-	74	-26.17	204	349	V
3	* 2.39	30.31	RMS	32.1	-24.7	37.71	54	-16.29	-	-	204	349	V

\* - indicates frequency in CFR 47, Part 15 and Industry Canada RSS-Restricted Band.

PK - Peak detector

RMS - RMS detection

**RESTRICTED BANDEDGE (HIGH CHANNEL, HORIZONTAL)**

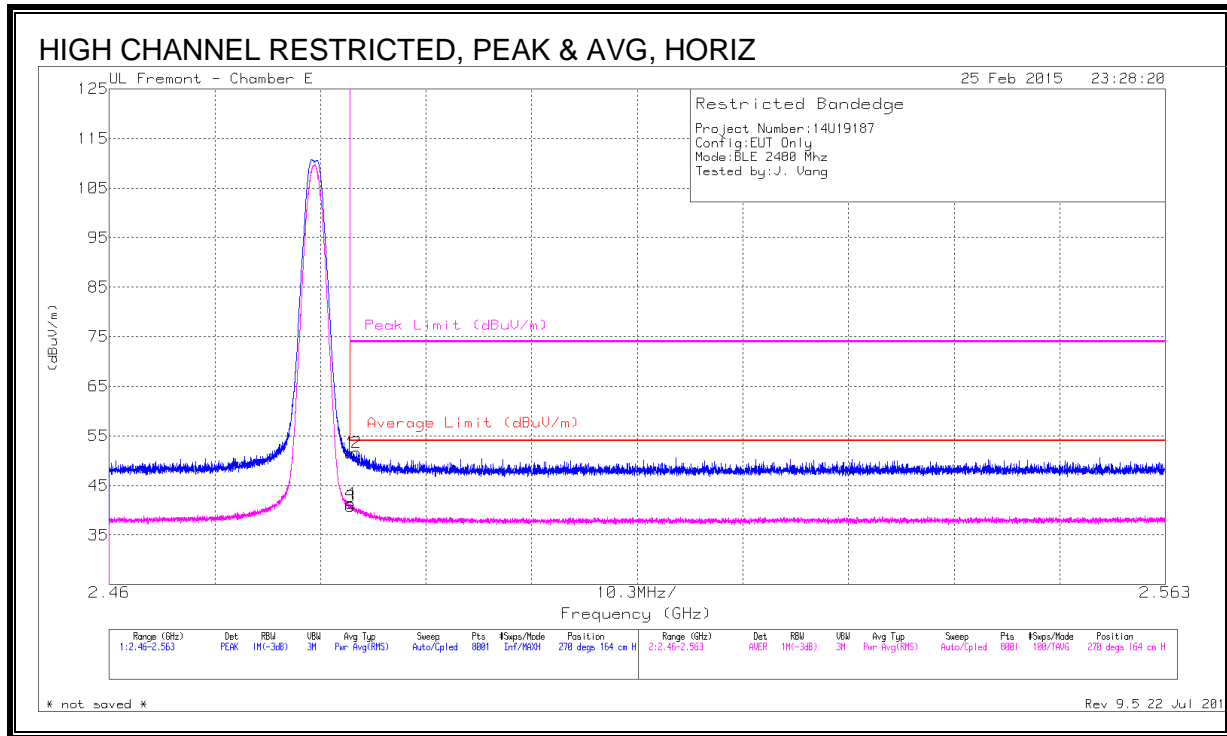

**DATA**

Marker	Frequency (GHz)	Meter Reading (dBuV)	Det	AF T346 (dB/m)	Amp/Cbl/Fltr/Pad (dB)	Corrected Reading (dBuV/m)	Average Limit (dBuV/m)	Margin (dB)	Peak Limit (dBuV/m)	PK Margin (dB)	Azimuth (Degs)	Height (cm)	Polarity
1	* 2.484	43.6	PK	32.2	-24.3	51.5	-	-	74	-22.5	270	164	H
2	* 2.484	43.7	PK	32.2	-24.3	51.6	-	-	74	-22.4	270	164	H
3	* 2.484	32.9	RMS	32.2	-24.3	40.8	54	-13.2	-	-	270	164	H
4	* 2.484	33.46	RMS	32.2	-24.3	41.36	54	-12.64	-	-	270	164	H

\* - indicates frequency in CFR 47, Part 15 and Industry Canada RSS-Restricted Band.

PK - Peak detector

RMS - RMS detection

**RESTRICTED BANDEDGE (HIGH CHANNEL, VERTICAL)**

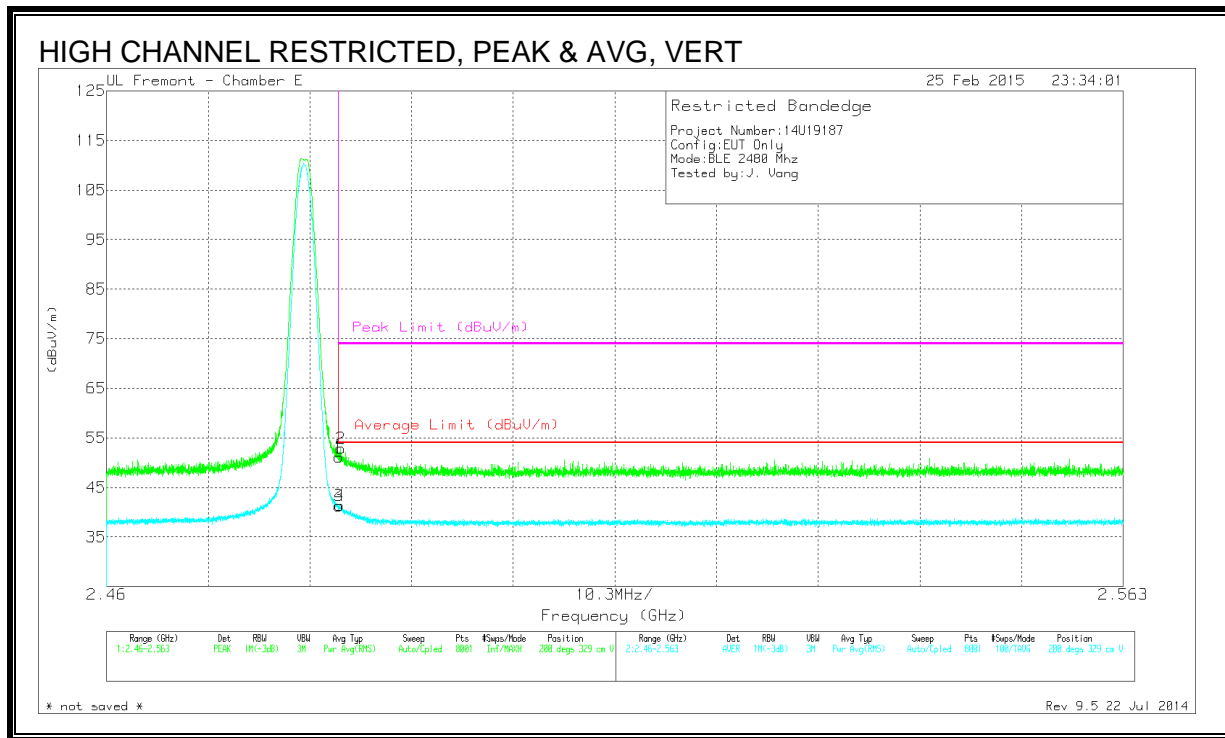

**DATA**

Marker	Frequency (GHz)	Meter Reading (dBuV)	Det	AF T346 (dB/m)	Amp/Cbl/ Ftr/Pad (dB)	Corrected Reading (dBuV/m)	Average Limit (dBuV/m)	Margin (dB)	Peak Limit (dBuV/m)	PK Margin (dB)	Azimuth (Degs)	Height (cm)	Polarity
1	* 2.484	43.2	PK	32.2	-24.3	51.1	-	-	74	-22.9	200	329	V
2	* 2.484	44.96	PK	32.2	-24.3	52.86	-	-	74	-21.14	200	329	V
3	* 2.484	33.39	RMS	32.2	-24.3	41.29	54	-12.71	-	-	200	329	V
4	* 2.484	33.5	RMS	32.2	-24.3	41.4	54	-12.6	-	-	200	329	V

\* - indicates frequency in CFR 47, Part 15 and Industry Canada RSS-Restricted Band.

PK - Peak detector

RMS - RMS detection

**LOW CHANNEL HARMONICS AND SPURIOUS EMISSIONS**

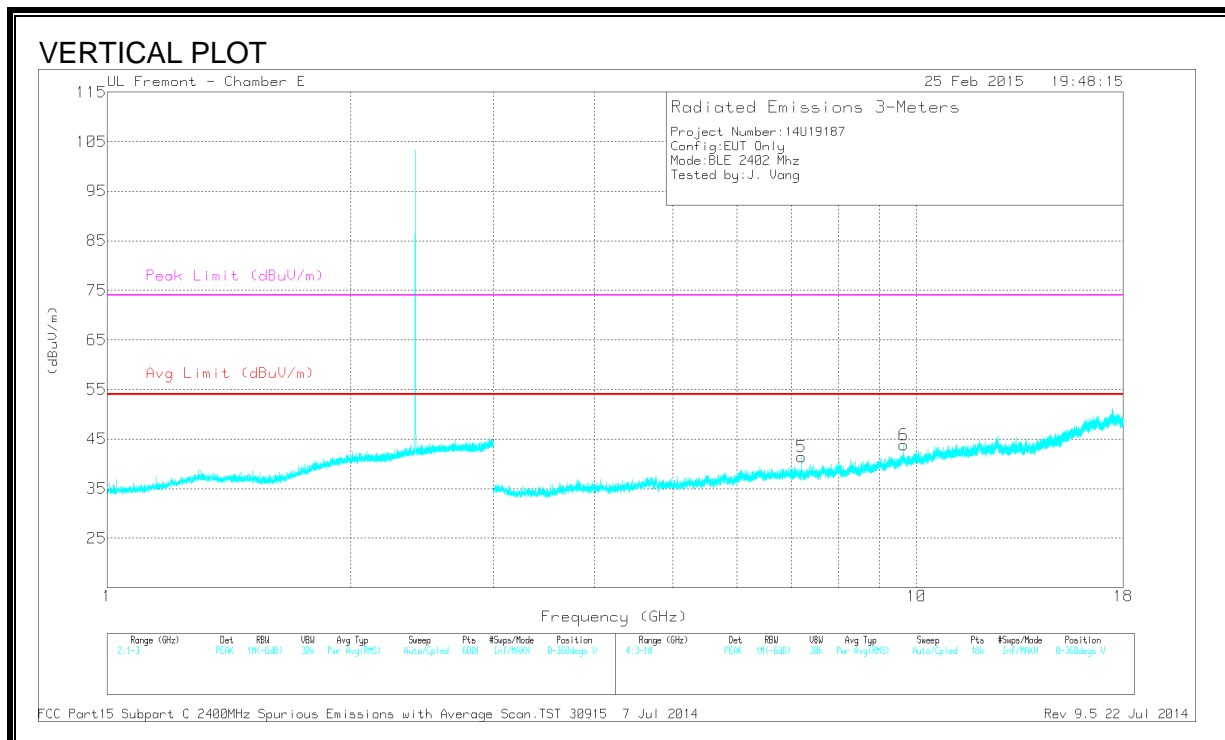
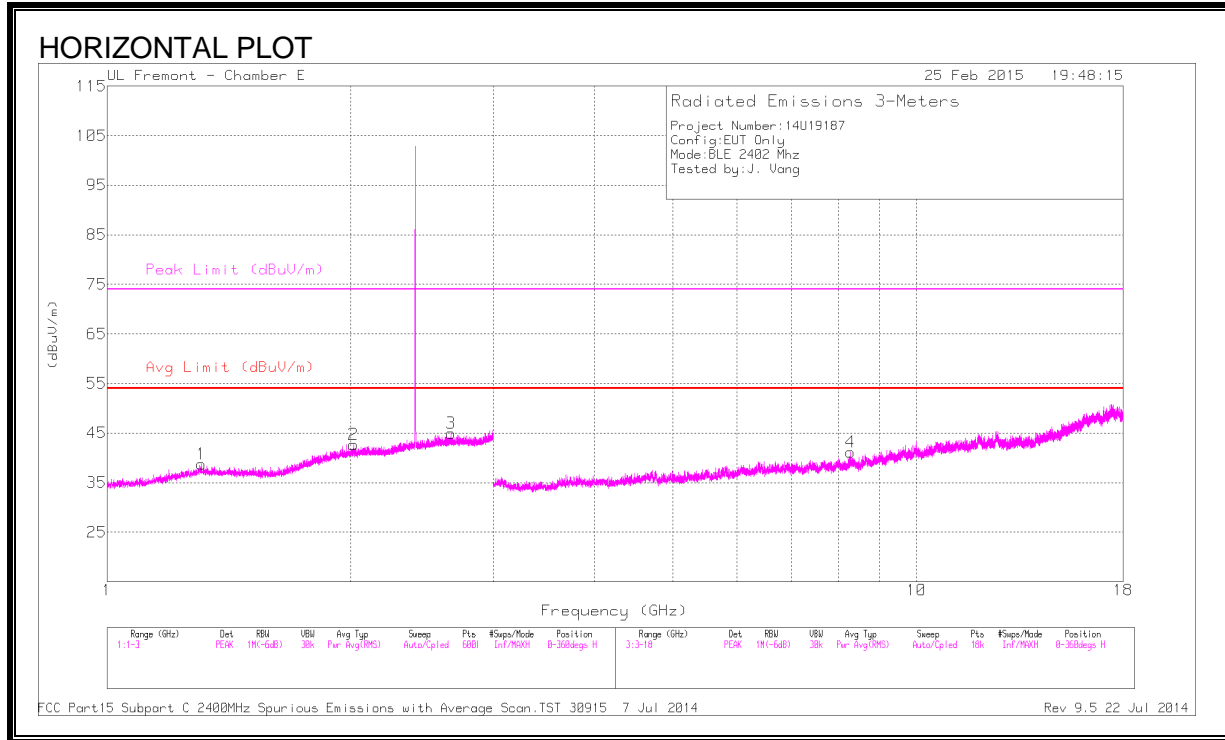

**DATA**

Marker	Frequency (GHz)	Meter Reading (dBuV)	Det	AF T346 (dB/m)	Amp/Cb/ Fitr/Pad (dB)	Corrected Reading (dBuV/m)	Avg Limit (dBuV/m)	Margin (dB)	Peak Limit (dBuV/m)	PK Margin (dB)	Azimuth (Degs)	Height (cm)	Polarity
1	* 1.308	44.44	PK2	29	-26.9	46.54	-	-	74	-27.46	328	185	H
	* 1.303	32.29	MAv1	29	-27	34.29	54	-19.71	-	-	328	185	H
3	* 2.662	43.96	PK2	32.4	-23.9	52.46	-	-	74	-21.54	345	216	H
	* 2.663	31.65	MAv1	32.4	-23.9	40.15	54	-13.85	-	-	345	216	H
4	* 8.281	38.5	PK2	35.7	-26.1	48.1	-	-	74	-25.9	308	321	H
	* 8.281	26.66	MAv1	35.7	-26.1	36.26	54	-17.74	-	-	308	321	H
2	2.013	43.54	PK2	31.3	-25	49.84	-	-	-	-	10	133	H
5	7.206	40.99	PK2	35.5	-28.4	48.09	-	-	-	-	330	208	V
6	9.635	37.02	PK2	36.9	-23.8	50.12	-	-	-	-	51	101	V

\* - indicates frequency in CFR 47, Part 15 and Industry Canada RSS-Restricted Band.

PK2 - KDB558074 Method: Maximum Peak

MAv1 - KDB558074 Option 1 Maximum RMS Average

**MID CHANNEL HARMONICS AND SPURIOUS EMISSIONS**

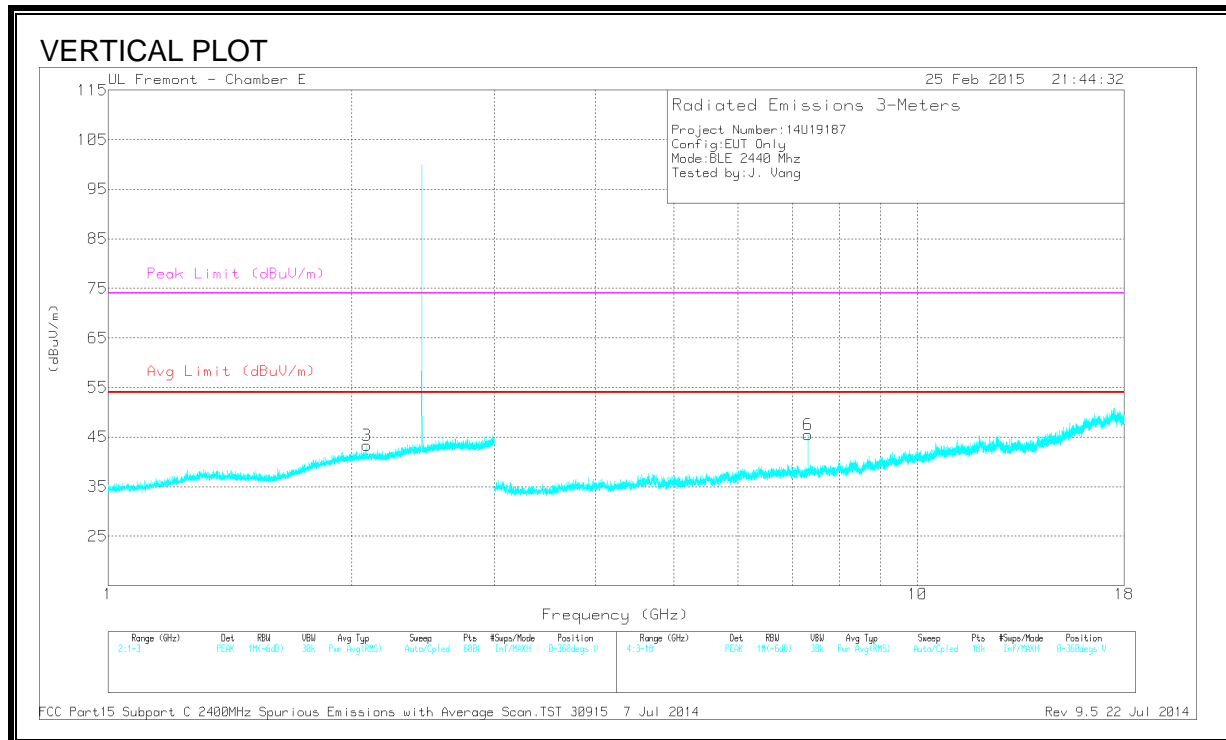
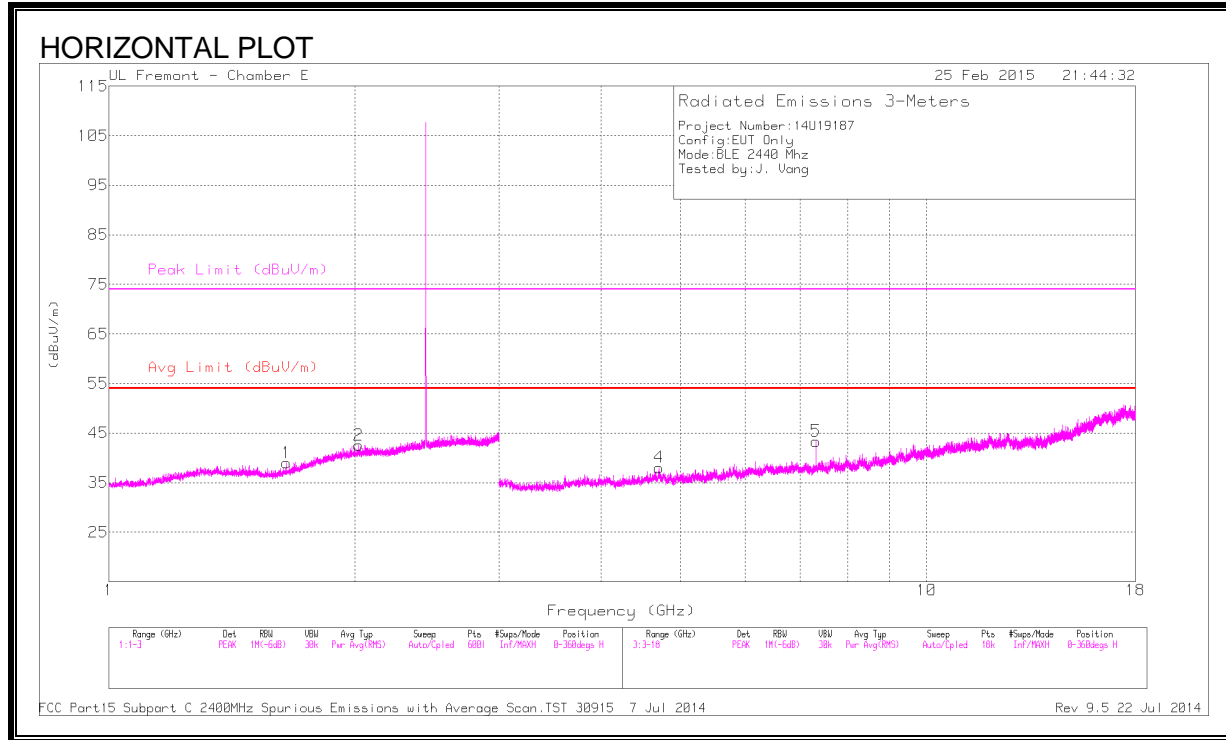



**DATA**

Marker	Frequency (GHz)	Meter Reading (dBuV)	Det	AF T346 (dB/m)	Amp/Cbl/Filtr/Pad (dB)	Corrected Reading (dBuV/m)	Avg Limit (dBuV/m)	Margin (dB)	Peak Limit (dBuV/m)	PK Margin (dB)	Azimuth (Degs)	Height (cm)	Polarity
4	* 4.708	42.71	PK2	34.2	-30.5	46.41	-	-	74	-27.59	71	290	H
	* 4.71	30.57	MAv1	34.2	-30.5	34.27	54	-19.73	-	-	71	290	H
5	* 7.321	42.44	PK2	35.5	-27.7	50.24	-	-	74	-23.76	152	221	H
	* 7.321	33.9	MAv1	35.5	-27.7	41.7	54	-12.3	-	-	152	221	H
6	* 7.32	44.6	PK2	35.5	-27.7	52.4	-	-	74	-21.6	251	178	V
	* 7.319	37.49	MAv1	35.5	-27.7	45.29	54	-8.71	-	-	251	178	V
1	1.652	44.16	PK2	28.4	-26.5	46.06	-	-	-	-	235	145	H
2	2.019	43.55	PK2	31.3	-24.9	49.95	-	-	-	-	315	211	H
3	2.088	43.27	PK2	31.3	-24.9	49.67	-	-	-	-	25	200	V

\* - indicates frequency in CFR 47, Part 15 and Industry Canada RSS-Restricted Band.

PK2 - KDB558074 Method: Maximum Peak

MAv1 - KDB558074 Option 1 Maximum RMS Average

**HIGH CHANNEL HARMONICS AND SPURIOUS EMISSIONS**

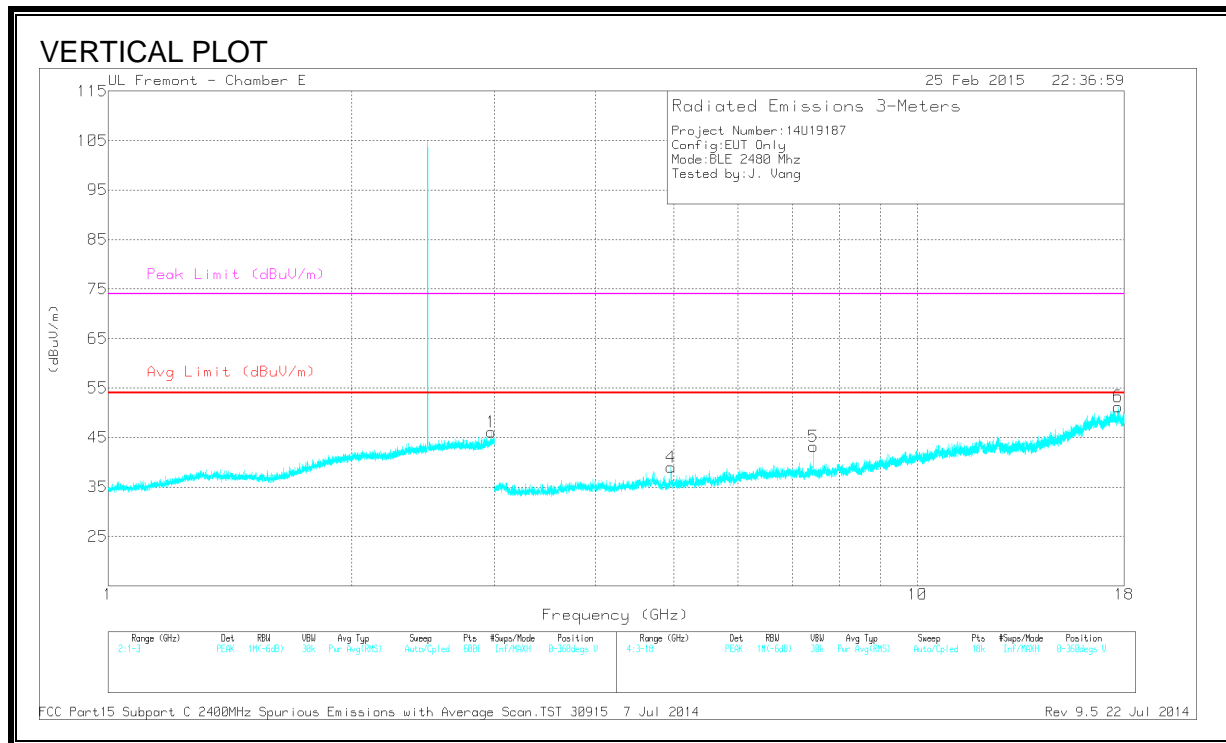
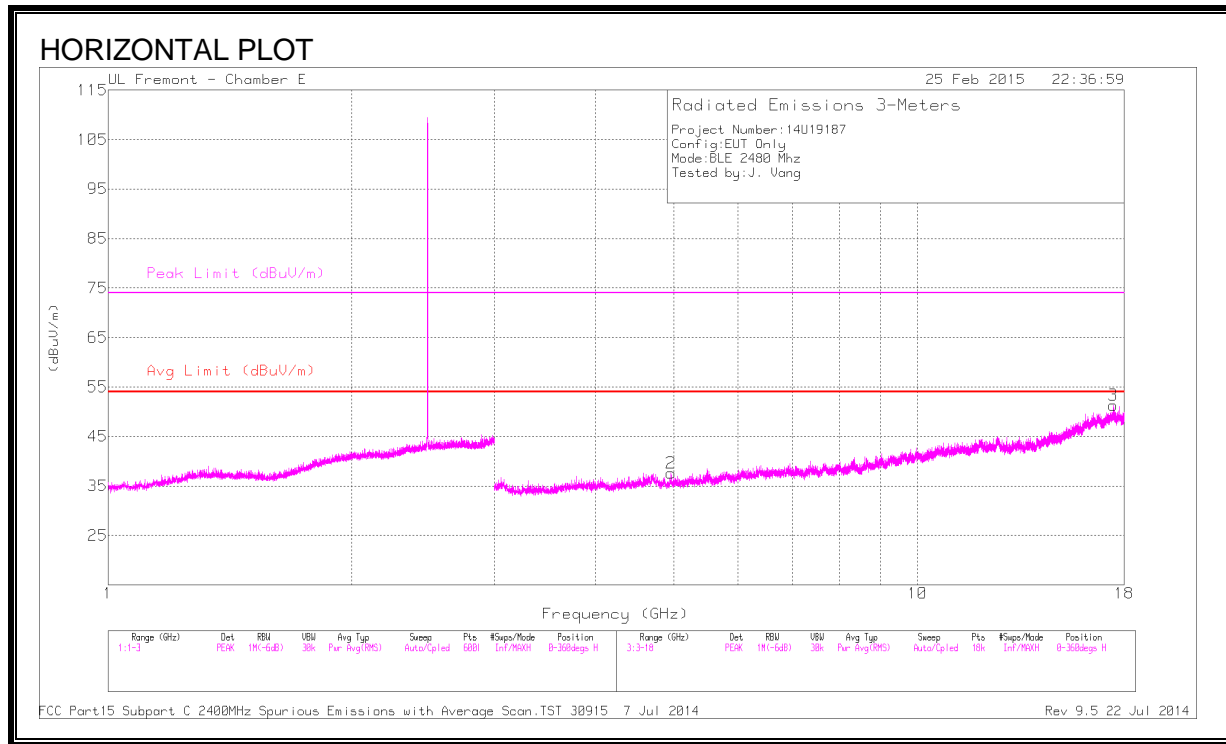

**DATA**

Marker	Frequency (GHz)	Meter Reading (dBuV)	Det	AFT346 (dB/m)	Amp/Cbl/ Fitr/Pad (dB)	Corrected Reading (dBuV/m)	Avg Limit (dBuV/m)	Margin (dB)	Peak Limit (dBuV/m)	PK Margin (dB)	Azimuth (Degs)	Height (cm)	Polarity
2	* 4.96	42.27	PK2	34.1	-30.2	46.17	-	-	74	-27.83	307	311	H
	* 4.96	32.62	MAv1	34.1	-30.2	36.52	54	-17.48	-	-	307	311	H
4	* 4.96	41.47	PK2	34.1	-30.2	45.37	-	-	74	-28.63	210	163	V
	* 4.96	32.38	MAv1	34.1	-30.2	36.28	54	-17.72	-	-	210	163	V
5	* 7.439	42.69	PK2	35.6	-28.2	50.09	-	-	74	-23.91	255	190	V
	* 7.441	33.88	MAv1	35.6	-28.2	41.28	54	-12.72	-	-	255	190	V
6	* 17.702	36.51	PK2	41.2	-19.3	58.41	-	-	74	-15.59	353	178	V
	* 17.702	24.34	MAv1	41.2	-19.3	46.24	54	-7.76	-	-	353	178	V
1	2.973	43.32	PK2	32.8	-23.7	52.42	-	-	-	-	61	212	V
3	17.448	34.96	PK2	41.2	-18.9	57.26	-	-	-	-	140	200	H

\* - indicates frequency in CFR 47, Part 15 and Industry Canada RSS-Restricted Band.

PK2 - KDB558074 Method: Maximum Peak

MAv1 - KDB558074 Option 1 Maximum RMS Average

### 9.3. WORST-CASE BELOW 1 GHz

#### SPURIOUS EMISSIONS 30 TO 1000 MHz (WORST-CASE CONFIGURATION)

#### ANTENNA B

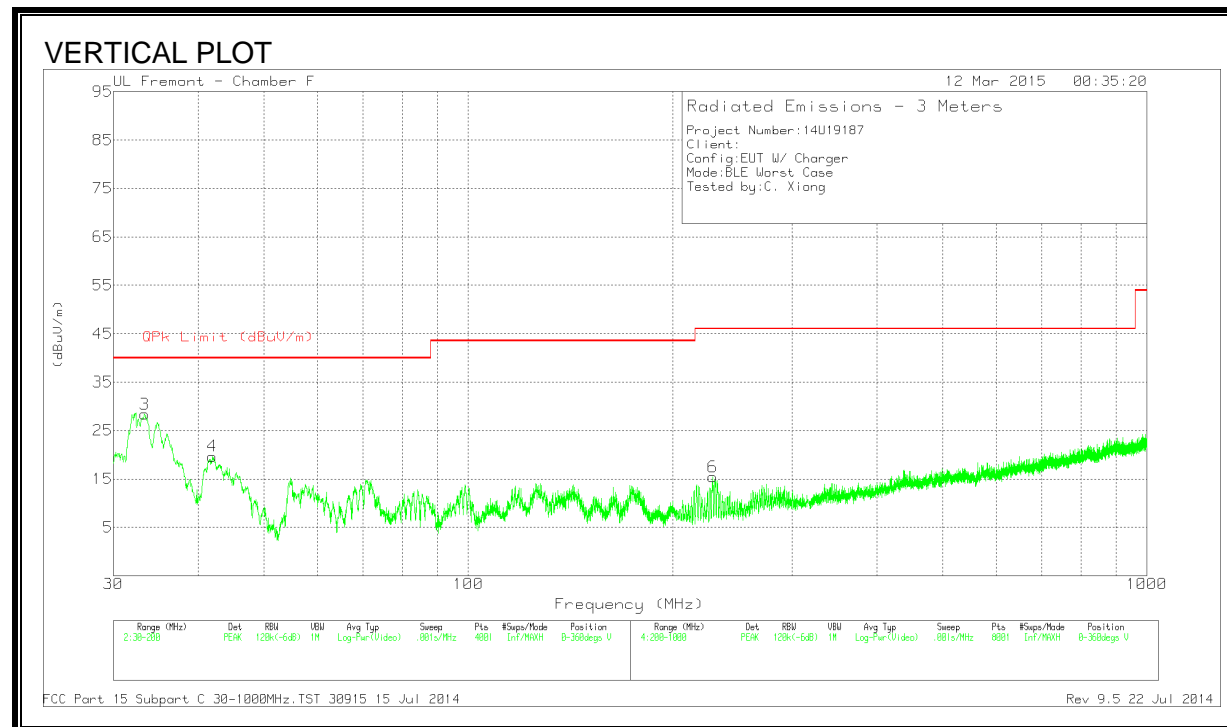
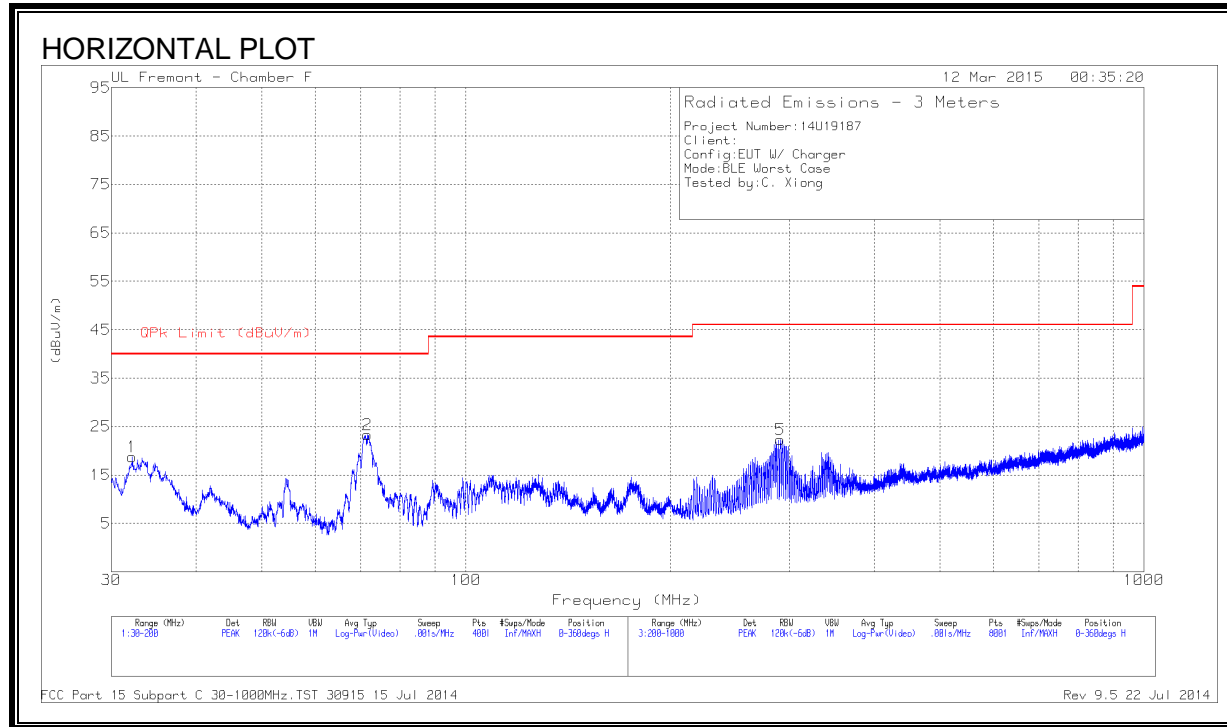

**DATA**

Marker	Frequency (MHz)	Meter Reading (dBuV)	Det	AF T122 (dB/m)	Amp/Cbl (dB)	Corrected Reading (dBuV/m)	QPk Limit (dBuV/m)	Margin (dB)	Azimuth (Degs)	Height (cm)	Polarity
1	32.21	31.19	PK	19.4	-31.9	18.69	40	-21.31	0-360	301	H
2	71.5225	46.36	PK	8.4	-31.5	23.26	40	-16.74	0-360	201	H
3	33.3575	41.49	PK	18.8	-31.9	28.39	40	-11.61	0-360	100	V
4	41.9425	38.8	PK	12.7	-31.8	19.7	40	-20.3	0-360	100	V
5	290.8	38.96	PK	13.4	-30.1	22.26	46.02	-23.76	0-360	100	H
6	229.1	34.81	PK	11	-30.4	15.41	46.02	-30.61	0-360	201	V

PK - Peak detector

**ANTENNA D**

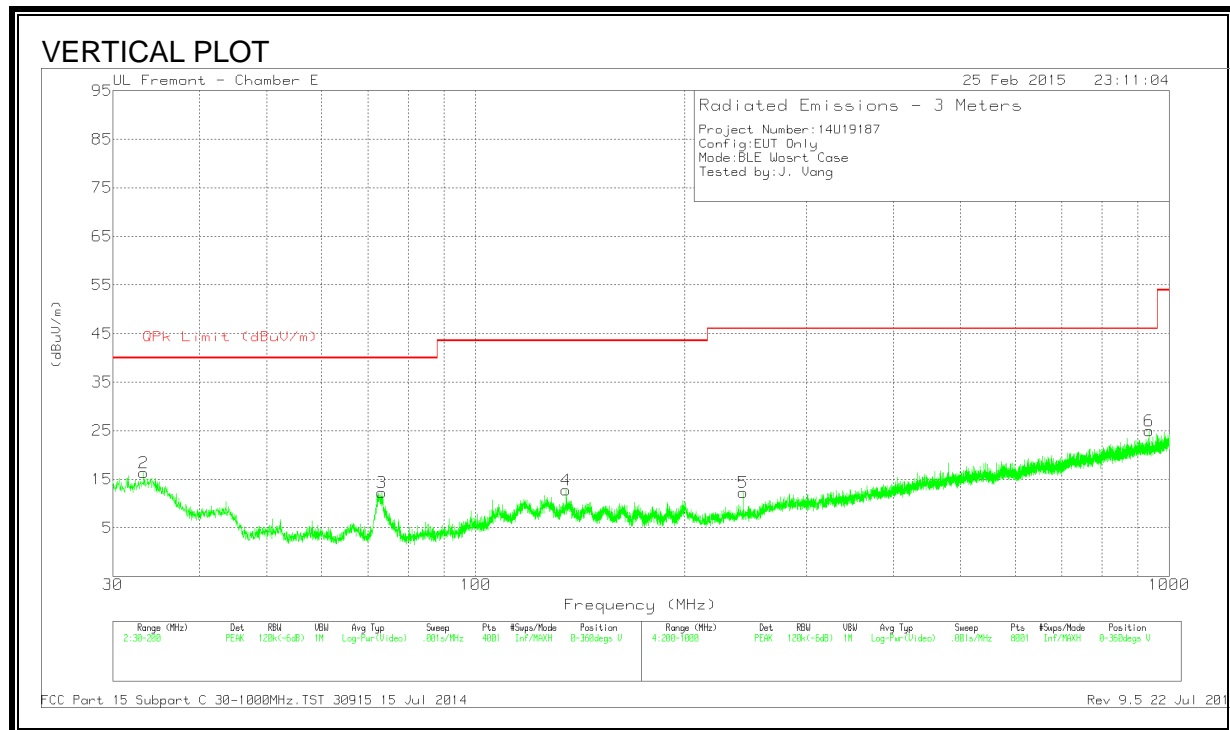
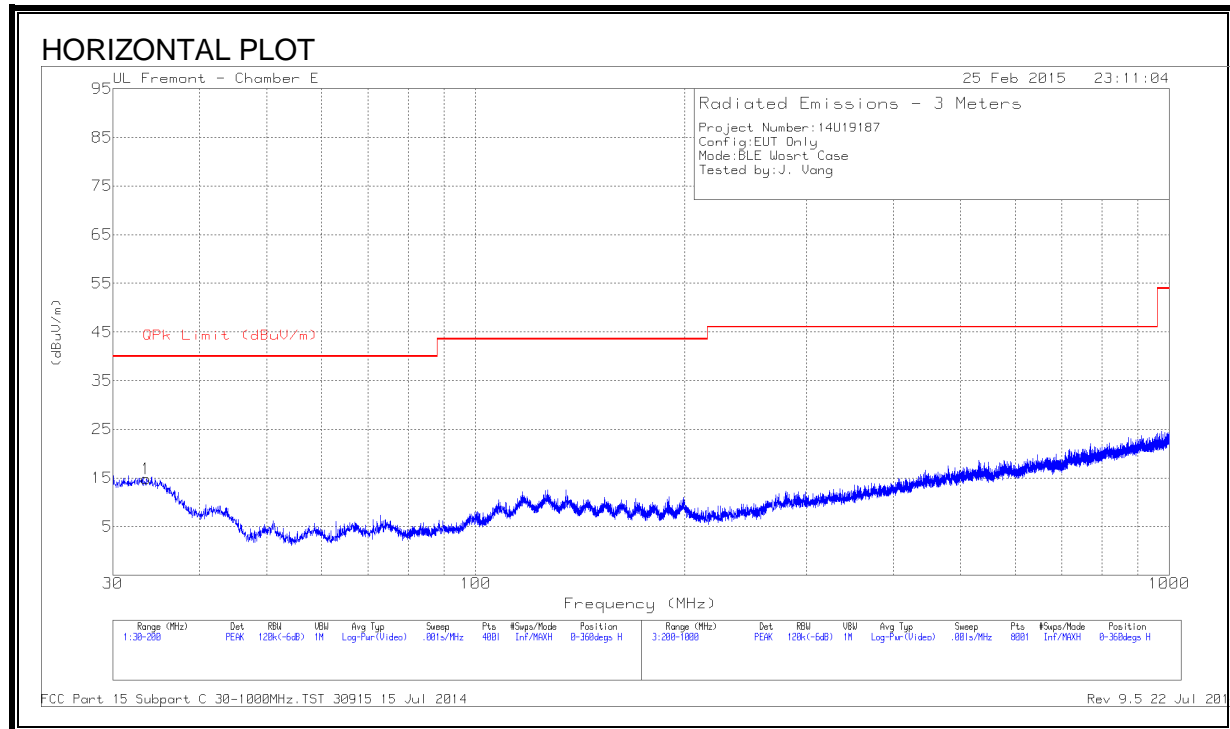

**DATA**

Marker	Frequency (MHz)	Meter Reading (dBuV)	Det	AFT408 (dB/m)	Amp/Cbl (dB)	Corrected Reading (dBuV/m)	QPk Limit (dBuV/m)	Margin (dB)	Azimuth (Degs)	Height (cm)	Polarity
3	* 73.18	35.28	PK	8.5	-31.5	12.28	40	-27.72	0-360	100	V
4	* 134.97	30.63	PK	13.3	-31.1	12.83	43.52	-30.69	0-360	100	V
5	* 243	31.26	PK	11.5	-30.5	12.26	46.02	-33.76	0-360	301	V
2	33.23	28.93	PK	19.2	-31.8	16.33	40	-23.67	0-360	100	V
1	33.52	27.66	PK	19	-31.8	14.86	40	-25.14	0-360	98	H
6	935.2	30.65	PK	22.1	-27.8	24.95	46.02	-21.07	0-360	99	V

\* - indicates frequency in CFR 47, Part 15 and Industry Canada RSS-Restricted Band.

PK - Peak detector

### 9.4. WORST-CASE ABOVE 18 GHz

#### ANTENNA B

#### SPURIOUS EMISSIONS 18000 TO 26000 MHz (WORST-CASE CONFIGURATION)

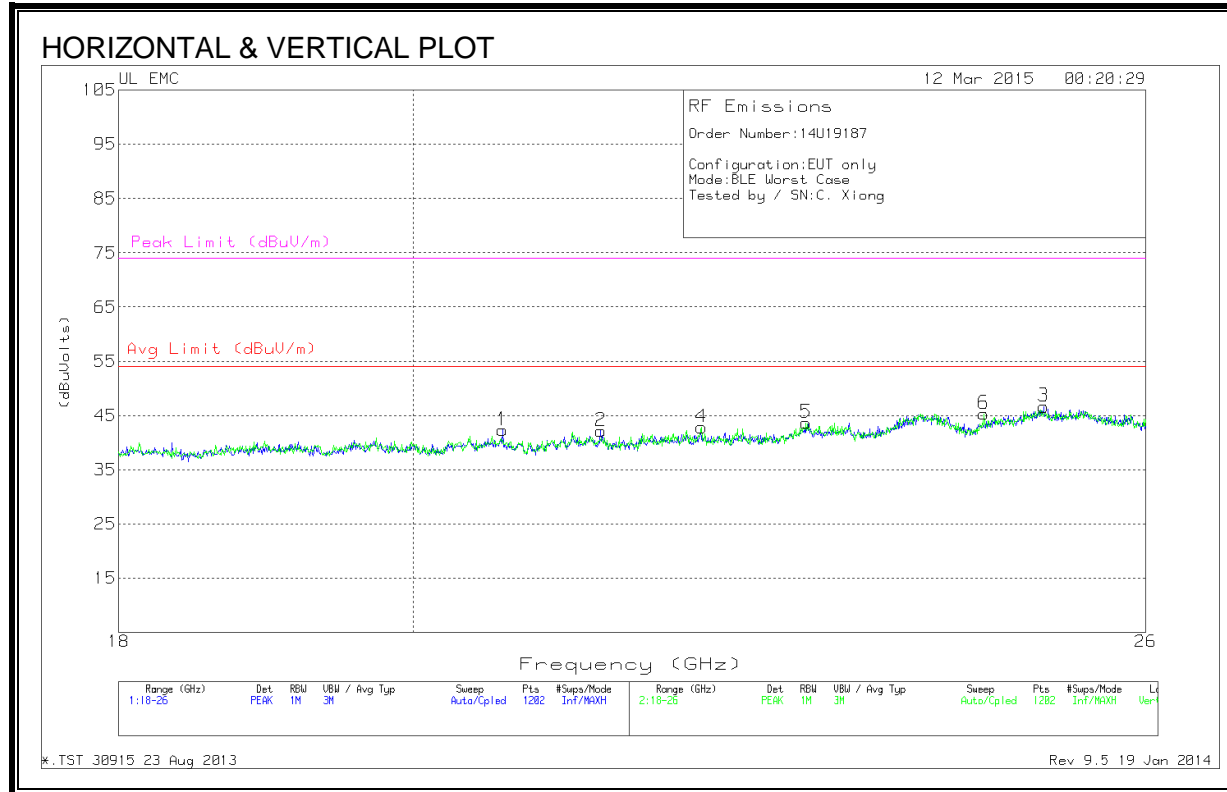

#### DATA

Marker	Frequency (GHz)	Meter Reading (dBuV)	Det	T89 AF (dB/m)	Amp/Cbl (dB)	Dist Corr (dB)	Corrected Reading (dBuVolts)	Avg Limit (dBuV/m)	Margin (dB)	Peak Limit (dBuV/m)	PK Margin (dB)
1	20.651	42.13	PK	33.1	-23.4	-9.5	42.333	54	-11.66	74	-31.666
2	21.391	42.07	PK	33.3	-23.7	-9.5	42.166	54	-11.83	74	-31.833
3	25.067	44.47	PK	34.5	-22.8	-9.5	46.666	54	-7.333	74	-27.333
4	22.177	41.73	PK	33.7	-23.1	-9.5	42.833	54	-11.16	74	-31.166
5	23.022	42.57	PK	34	-23.4	-9.5	43.666	54	-10.33	74	-30.333
6	24.535	43.43	PK	34.2	-22.8	-9.5	45.333	54	-8.66	74	-28.666

PK - Peak detector



**ANTENNA D**

**SPURIOUS EMISSIONS 1800 TO 26000 MHz (WORST-CASE CONFIGURATION)**

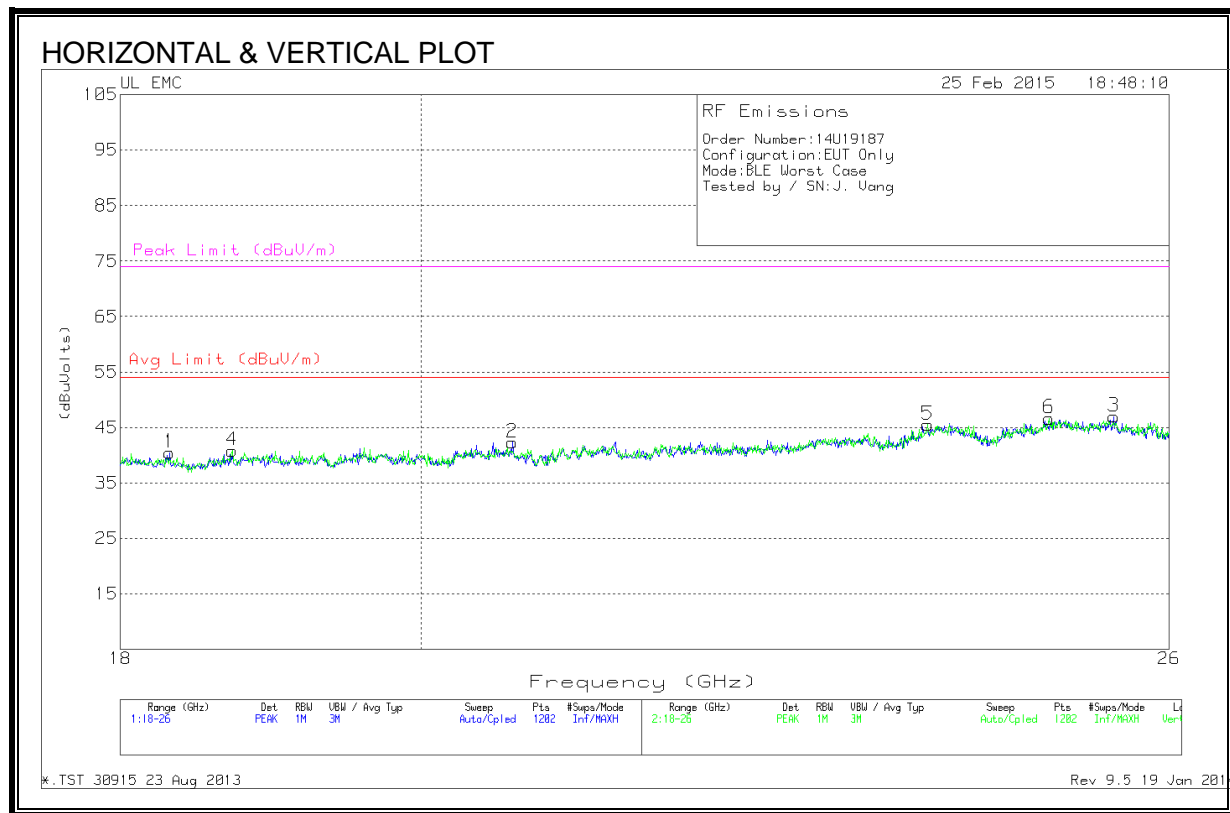

**DATA**

Marker	Frequency (GHz)	Meter Reading (dBuV)	Det	T89 AF (dB/m)	Amp/Cbl (dB)	Dist Corr (dB)	Corrected Reading (dBuVolts)	Avg Limit (dBuV/m)	Margin (dB)	Peak Limit (dBuV/m)	PK Margin (dB)
1	18.313	42.1	PK	32.5	-24.6	-9.5	40.5	54	-13.5	74	-33.5
2	20.651	42.13	PK	33.1	-23.4	-9.5	42.3	54	-11.6	74	-31.6
3	25.5	45	PK	34.7	-23.2	-9.5	47	54	-7	74	-27
4	18.719	41.73	PK	32.7	-24.1	-9.5	40.8	54	-13.1	74	-33.1
5	23.888	43.5	PK	34.2	-22.7	-9.5	45.5	54	-8.5	74	-28.5
6	24.928	44.37	PK	34.5	-22.7	-9.5	46.6	54	-7.3	74	-27.3

PK - Peak detector

## 9.5. AC POWER LINE CONDUCTED EMISSIONS

### LIMITS

FCC §15.207 (a)

RSS-Gen 8.8

Frequency of emission (MHz)	Conducted limit (dB $\mu$ V)	
	Quasi-peak	Average
0.15-0.5	66 to 56*	56 to 46*
0.5-5	56	46
5-30	60	50

\*Decreases with the logarithm of the frequency.

### TEST PROCEDURE

ANSI C63.4

### RESULTS

**6 WORST EMISSIONS**

**Line-L1 .15 - 30MHz**

**Trace Markers**

Marker	Frequency (MHz)	Meter Reading (dBuV)	Det	T24 IL L1 (dB)	LC Cables 1&3 (dB)	Corrected Reading dBuV	CISPR 22 Class B QP	Margin to Limit (dB)	CISPR 22 Class B Avg	Margin to Limit (dB)
1	.204	37.78	PK	.9	0	38.68	63.4	-24.72	-	-
2	.204	30.73	Av	.9	0	31.63	-	-	53.4	-21.77
3	.591	42.16	PK	.3	0	42.46	56	-13.54	-	-
4	.591	30.46	Av	.3	0	30.76	-	-	46	-15.24
5	1.5855	32.87	PK	.2	.1	33.17	56	-22.83	-	-
6	1.5855	19.07	Av	.2	.1	19.37	-	-	46	-26.63
7	8.9295	28.81	PK	.2	.1	29.11	60	-30.89	-	-
8	8.9295	18.56	Av	.2	.1	18.86	-	-	50	-31.14

**Line-L2 .15 - 30MHz**

**Trace Markers**

Marker	Frequency (MHz)	Meter Reading (dBuV)	Det	T24 IL L2 (dB)	LC Cables 2&3 (dB)	Corrected Reading dBuV	CISPR 22 Class B QP	Margin to Limit (dB)	CISPR 22 Class B Avg	Margin to Limit (dB)
9	.204	37.25	PK	1	0	38.25	63.4	-25.15	-	-
10	.204	28.71	Av	1	0	29.71	-	-	53.4	-23.69
11	.6	38.58	PK	.3	0	38.88	56	-17.12	-	-
12	.6	23.44	Av	.3	0	23.74	-	-	46	-22.26
13	1.608	28.51	PK	.2	.1	28.81	56	-27.19	-	-
14	1.608	11.09	Av	.2	.1	11.39	-	-	46	-34.61
15	8.961	31.16	PK	.2	.1	31.46	60	-28.54	-	-
16	8.961	20.5	Av	.2	.1	20.8	-	-	50	-29.2

PK - Peak detector

Av - average detection

**LINE 1 RESULTS**

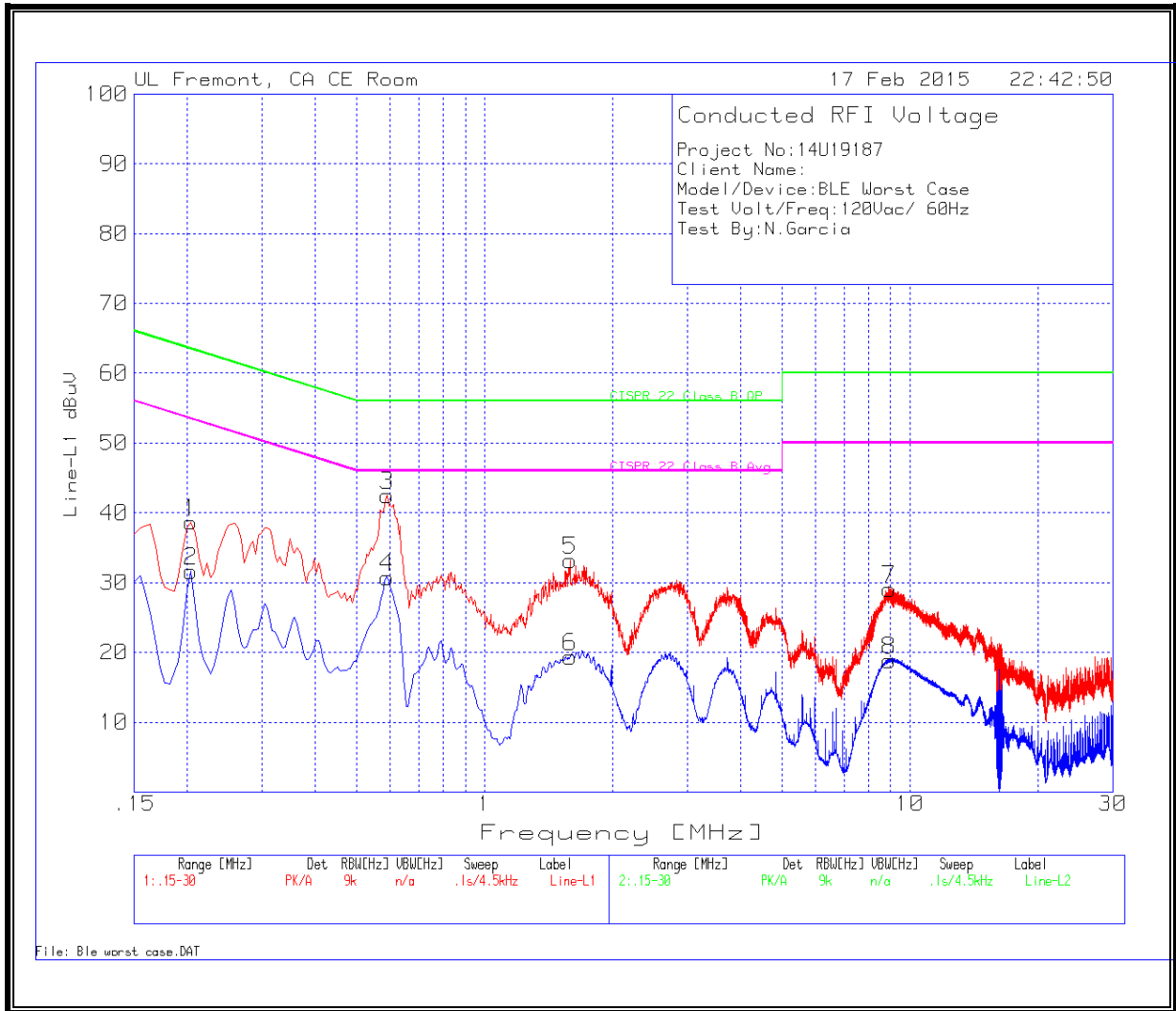

**LINE 2 RESULTS**

