

7 Series

700A11

Geothermal Heat Pump

- R-410A Refrigerant
- 3, 4, 5 Ton Variable Speed

Installation Information

Water Piping Connections

Hot Water Generator Connections

Electrical

Startup Procedures

Troubleshooting

Preventive Maintenance



Table of Contents

Model Nomenclature.....	4
General Installation Information.....	5
Flow Centers.....	9
Closed Loop Ground Source Systems.....	10
Open Loop Ground Water Systems.....	12
Hot Water Generator Connections.....	13
Electrical Connections.....	15
Electronic Thermostat Installation.....	21
Auxiliary Heat Ratings.....	22
Auxiliary Heat Electrical Data.....	22
Electrical Data.....	22
Blower Performance Data.....	23
Dimensional Data.....	24
Physical Data.....	28
The Aurora™ Advanced VS Control System.....	29
Operation Logic.....	39
Wiring Schematics.....	40
Unit Startup.....	47
Pressure Drop.....	50
Thermistor Resistance.....	50
Antifreeze Corrections.....	50
Correction Factor Tables.....	51
Compressor Resistance.....	52
Refrigerant Circuit Guideline.....	52
Heat of Extraction/Rejection.....	52
Operating Parameters.....	53
Reference Calculations and Legend.....	54
Troubleshooting.....	54
Preventive Maintenance and Replacement Procedures.....	58
Service Parts List.....	59

Model Nomenclature

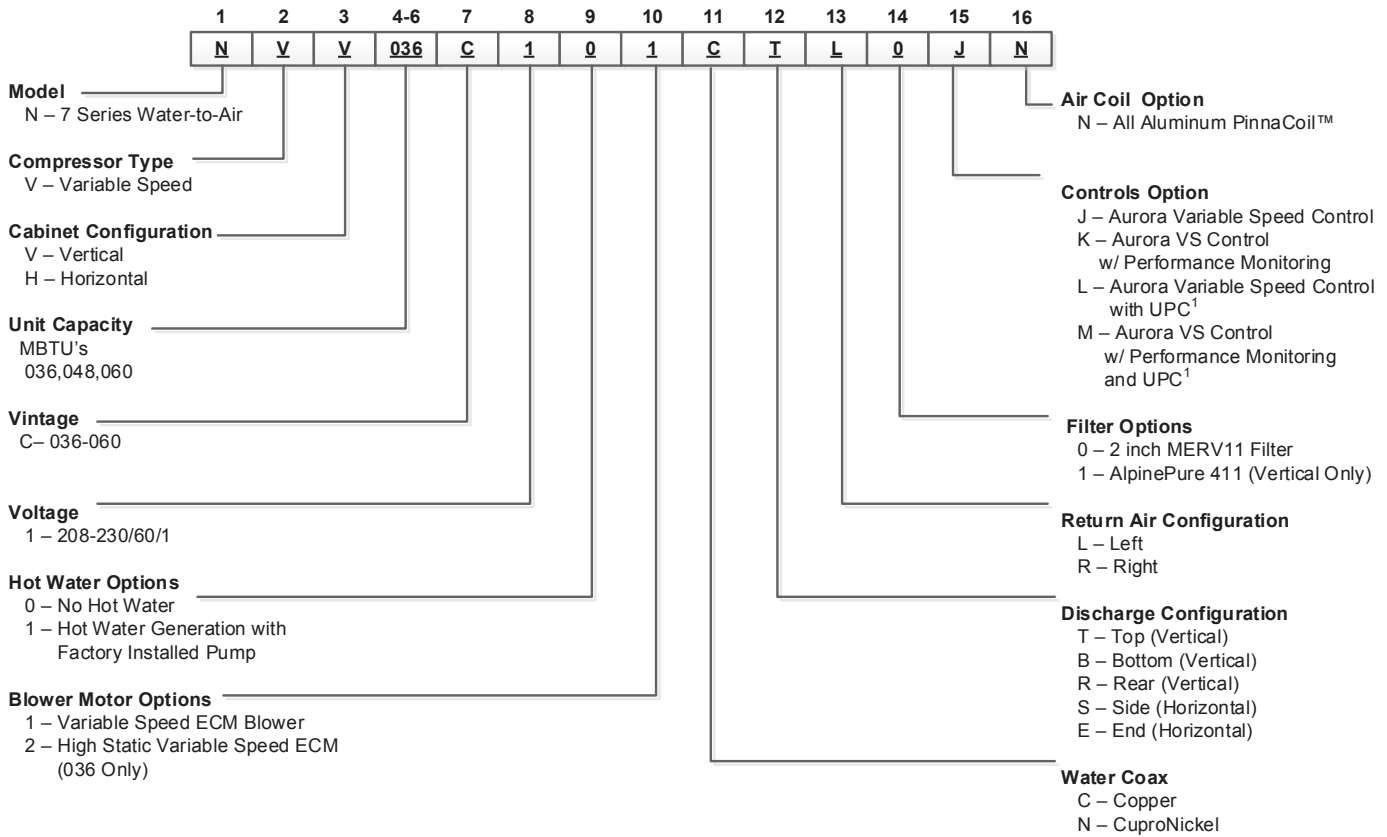

Rev.: 1/22/2021

Notes:

¹ UPC is not compatible with Symphony or IntelliZone2

General Installation Information

Safety Considerations



WARNING: Before performing service or maintenance operations on a system, turn off main power switches to the indoor unit. If applicable, turn off the accessory heater power switch. Electrical shock could cause personal injury.

Installing and servicing heating and air conditioning equipment can be hazardous due to system pressure and electrical components. Only trained and qualified service personnel should install, repair or service heating and air conditioning equipment. Untrained personnel can perform the basic maintenance functions of cleaning coils and cleaning and replacing filters. All other operations should be performed by trained service personnel. When working on heating and air conditioning equipment, observe precautions in the literature, tags and labels attached to the unit and other safety precautions that may apply.

Follow all safety codes. Wear safety glasses and work gloves. Use a quenching cloth for brazing operations and have a fire extinguisher available.

Moving and Storage

Move units in the normal “up” orientation. Horizontal units may be moved and stored per the information on the packaging. Do not stack more than three units in total height. Vertical units may be stored one upon another to a maximum height of two units. Do not attempt to move units while stacked. When the equipment is received, all items should be carefully checked against the bill of lading to be sure all crates and cartons have been received. Examine units for shipping damage, removing the units from the packaging if necessary. Units in question should also be internally inspected. If any damage is noted, the carrier should make the proper notation on the delivery receipt, acknowledging the damage.

Unit Location

Locate the unit in an indoor area, minimum ambient of 45°F and maximum ambient of 100°F, that allows for easy removal of the filter and access panels. Attic installations are not approved and could result in loss of warranty. Installation is not recommended in areas with excessive dirt and debris as this may be drawn into the VS drive causing overheating of the VS drive. Location should have enough space for service personnel to perform maintenance or repair. Provide sufficient room to make water, electrical and duct connection(s). If the unit is located in a confined space, such as a closet, provisions must be made for return air to freely enter the space by means of a louvered door, etc. Any access panel screws that would be difficult to remove after the unit is installed should be removed prior to setting the unit. On horizontal units, allow adequate room below the unit for a condensate drain trap and do not

locate the unit above supply piping. **Care should be taken when units are located in unconditioned spaces to prevent damage from frozen water lines and excessive heat that could damage electrical components.**

Filter Rack Conversion

A 2 in. MERV 11 filter is shipped with the heat pump. To field convert the filter rack to use 1 in. filters, simply insert the provided plastic push pins into the holes located in the filter rack. There are holes on the top and bottom of the rack, underneath the instruction labels, for field conversion to 1 in. filters.

Installing Vertical Units

Prior to setting the unit in place, remove and discard the compressor hold down shipping bolt located at the front of the compressor mounting bracket.

Vertical units are available in left or right air return configurations. Top and rear air discharge vertical units should be mounted level on a vibration absorbing pad slightly larger than the base to provide isolation between the unit and the floor. It is not necessary to anchor the unit to the floor (see below).

Bottomflow units should be mounted level and sealed well to floor to prevent air leakage. Bottomflow units require the supply air opening to be cut at least 1/2 in. larger than the unit’s air outlet. Protect the edges of combustible flooring with sheet metal over-wrap or other non-combustible material.

Figure 1: Vertical Unit Mounting



General Installation Information cont.

Installing Horizontal Units

Remove and discard the compressor hold down shipping bolt located at the front of the compressor mounting bracket prior to setting the unit in place. Horizontal units are available with side or end discharge. Horizontal units are normally suspended from a ceiling by four or six 3/8 in. diameter threaded rods. The rods are usually attached to the unit by hanger bracket kits furnished with each unit.

Lay out the threaded rods per the dimensions in Figure 3. Assemble the hangers to the unit as shown. Securely tighten the brackets to the unit using the weld nuts located on the underside of the bottom panel. When attaching the hanger rods to the bracket, a double nut is required since

vibration could loosen a single nut. To allow filter access, one bracket on the filter side should be installed 180° from the position shown in Figure 3. The unit should be pitched approximately 1/4-inch towards the drain in both directions to facilitate the removal of condensate. Use only the bolts provided in the kit to attach hanger brackets. The use of longer bolts could damage internal parts.

Some residential applications require the installation of horizontal units on an attic floor. In this case, the unit should be set in a full size secondary drain pan on top of a vibration absorbing pad. The secondary drain pan prevents possible condensate overflow or water leakage damage to the ceiling. The secondary drain pan is usually placed on a plywood base isolated from the ceiling joists by additional layers of vibration absorbing material.

Figure 2: Horizontal Unit Mounting

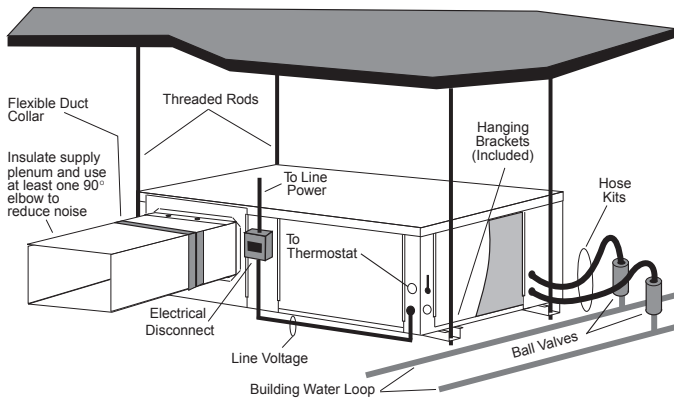

SPECIAL NOTE: The VS drive is limited to a maximum of 125°F ambient temperature. For this reason the 7 Series is not approved for attic installations. The compressor compartment temperature is also monitored by the Aurora. This ‘compressor ambient’ temperature is available on the AID Tool for reading. The control will de-rate the compressor when ambient air is above 125°F. Installing this product in an attic could result in loss of warranty.



CAUTION: Do not use rods smaller than 3/8-inch diameter since they may not be strong enough to support the unit. The rods must be securely anchored to the ceiling.

Figure 3: Hanger Location and Assembly

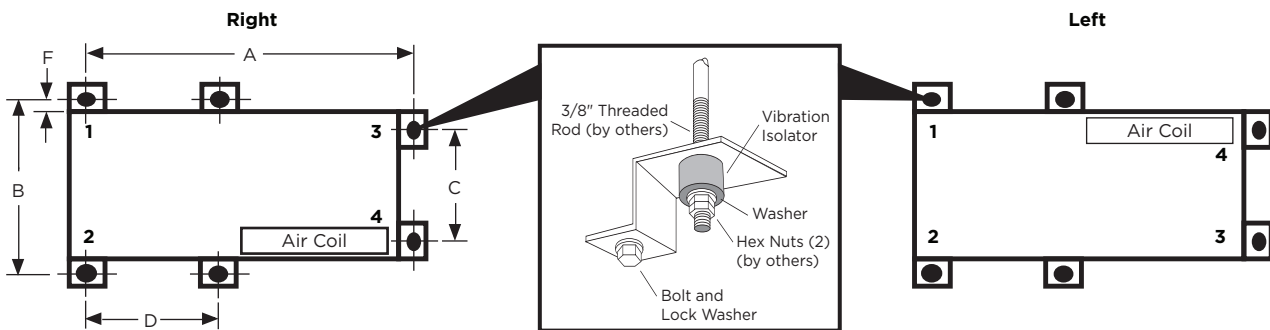

Hanger Dimensions

Model	Hanger Kit Part Number	Unit Hanger Dimensions			
		A	B	C	D
036	in.	77.4	27.8	24.1	29.3
	cm.	196.6	70.6	61.2	74.4
048	in.	77.4	27.8	24.1	29.3
	cm.	196.6	70.6	61.2	74.4
060	in.	82.4	27.8	24.1	29.3
	cm.	209.3	70.6	61.2	74.4

6/1/12

Weight Distribution

Model	Vertical Shipping Weight	Horizontal Shipping Weight	Horizontal Weight Distribution			
			Front		Back	
			1	2	3	4
036	331	365	120	80	83	82
048	354	388	143	84	81	80
060	372	402	143	198	81	80

Weights are listed in lbs. [kg]

12/03/20

General Installation Information cont.

Duct System

An air outlet collar is provided on vertical top and rear air discharge units and all horizontal units to facilitate a duct connection (vertical bottomflow units have no collar). A flexible connector is recommended for discharge and return air duct connections on metal duct systems. Uninsulated duct should be insulated with a minimum of 1-inch duct insulation. Application of the unit to uninsulated ductwork in an unconditioned space is not recommended as the unit's performance will be adversely affected.

If the unit is connected to existing ductwork, check the duct system to ensure that it has the capacity to accommodate the air required for the unit application. If the duct is too small, as in the replacement of heating only systems, larger ductwork should be installed. All existing ductwork should be checked for leaks and repaired if necessary.

The duct system should be sized according to the table below to handle the design airflow quietly and efficiently. To maximize sound attenuation of the unit blower, the supply and return plenums should include an internal duct liner of fiberglass or constructed of ductboard for the first few feet. On systems employing a sheet metal duct system, canvas connectors should be used between the unit and the ductwork. If air noise or excessive airflow is a problem, the blower speed can be changed.

Model	Design Airflow
NV036	1500
NV048	1800
NV060	2100

Water Piping

The proper water flow must be provided to each unit whenever the unit operates. To assure proper flow, use pressure/temperature ports to determine the flow rate. These ports should be located at the supply and return water connections on the unit. The proper flow rate cannot be accurately set without measuring the water pressure drop through the refrigerant-to-water heat exchanger.

All source water connections on residential units are swivel piping fittings (see Figure 4) that accept a 1-inch male pipe thread (MPT). The swivel connector has a rubber gasket seal similar to a rubber hose gasket, which when mated to the flush end of any 1-inch threaded pipe provides a leak-free seal without the need for thread sealing tape

or compound. Check to ensure that the rubber seal is in the swivel connector prior to attempting any connection. The rubber seals are shipped attached to the waterline. To make the connection to a ground loop system, mate the brass connector (supplied in CK4LI connector kit) against the rubber gasket in the swivel connector and thread the female locking ring onto the pipe threads, while maintaining the brass connector in the desired direction. Tighten the connectors by hand, then gently snug the fitting with pliers to provide a leak-proof joint. When connecting to an open loop (ground water) system, thread any 1-inch MPT fitting (SCH80 PVC or copper) into the swivel connector and tighten in the same manner as noted above. The open and closed loop piping system should include pressure/temperature taps for serviceability.

Never use flexible hoses smaller than 1-inch inside diameter on the unit. Limit hose length to 10 feet per connection. Check carefully for water leaks.

Figure 4: Swivel Connections

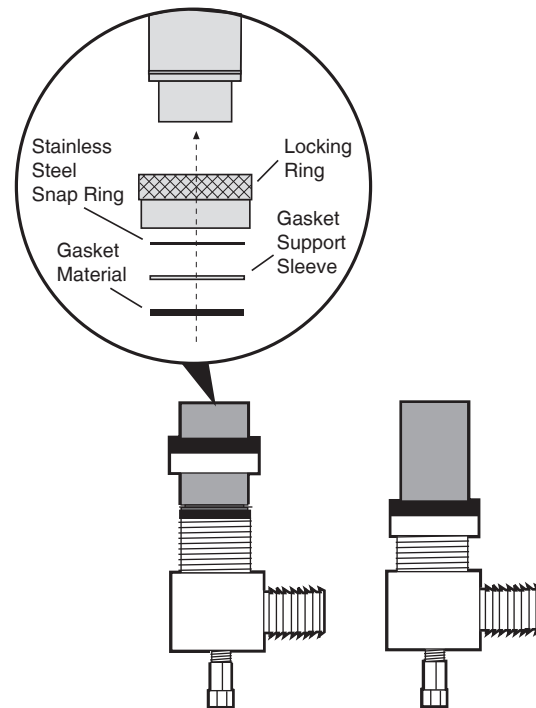

General Installation Information cont.

Material		Copper	90/10 Cupronickel	316 Stainless Steel
pH	Acidity/Alkalinity	7 - 9	7 - 9	7 - 9
Scaling	Calcium and Magnesium Carbonate	(Total Hardness) less than 350 ppm	(Total Hardness) less than 350 ppm	(Total Hardness) less than 350 ppm
Corrosion	Hydrogen Sulfide	Less than 0.5 ppm (rotten egg smell appears at 0.5 ppm)	10 - 50 ppm	Less than 1 ppm
	Sulfates	Less than 125 ppm	Less than 125 ppm	Less than 200 ppm
	Chlorine	Less than 0.5 ppm	Less than 0.5 ppm	Less than 0.5 ppm
	Chlorides	Less than 20 ppm	Less than 125 ppm	Less than 300 ppm
	Carbon Dioxide	Less than 50 ppm	10 - 50 ppm	10 - 50 ppm
	Ammonia	Less than 2 ppm	Less than 2 ppm	Less than 20 ppm
	Ammonia Chloride	Less than 0.5 ppm	Less than 0.5 ppm	Less than 0.5 ppm
	Ammonia Nitrate	Less than 0.5 ppm	Less than 0.5 ppm	Less than 0.5 ppm
	Ammonia Hydroxide	Less than 0.5 ppm	Less than 0.5 ppm	Less than 0.5 ppm
	Ammonia Sulfate	Less than 0.5 ppm	Less than 0.5 ppm	Less than 0.5 ppm
	Total Dissolved Solids (TDS)	Less than 1000 ppm	1000 - 1500 ppm	1000 - 1500 ppm
LSI Index	+0.5 to -0.5	+0.5 to -0.5	+0.5 to -0.5	
Iron Fouling (Biological Growth)	Iron, FE ²⁺ (Ferrous) Bacterial Iron Potential	< 0.2 ppm	< 0.2 ppm	< 0.2 ppm
	Iron Oxide	Less than 1 ppm, above this level deposition will occur	Less than 1 ppm, above this level deposition will occur	Less than 1 ppm, above this level deposition will occur
Erosion	Suspended Solids	Less than 10 ppm and filtered for max. of 600 micron size	Less than 10 ppm and filtered for max. of 600 micron size	Less than 10 ppm and filtered for max. of 600 micron size
	Threshold Velocity (Fresh Water)	< 6 ft/sec	< 6 ft/sec	< 6 ft/sec

NOTES: Grains = ppm divided by 17
mg/L is equivalent to ppm

2/22/12

Water Quality

It is the responsibility of the system designer and installing contractor to ensure that acceptable water quality is present and that all applicable codes have been met in these installations. Failure to adhere to the guidelines in the water quality table could result in loss of warranty. In ground water situations where scaling could be heavy or where biological growth such as iron bacteria will be present, a closed loop system is recommended. The heat exchanger coils in ground water systems may, over a period of time, lose heat exchange capabilities due to a buildup of mineral deposits inside. These can be cleaned, but only by a qualified service mechanic, as special solutions and pumping equipment are required. Hot water generator coils can likewise become scaled and possibly plugged. In areas with extremely hard water, the owner should be informed that the heat exchanger may require occasional flushing.

Heat pumps with cupronickel heat exchangers are recommended for open loop applications due to the increased resistance to build-up and corrosion, along with reduced wear caused by acid cleaning.

Water Treatment

Do not use untreated or improperly treated water. Equipment damage may occur. The use of improperly treated or untreated water in this equipment may result in scaling, erosion, corrosion, algae or slime. Purchase of a pre-mix antifreeze could significantly improve system reliability if the water quality is controlled and there are additives in the mixture to inhibit corrosion. There are many examples of such fluids on the market today such as Environol™ 1000 (pre-mix ethanol), and others. The services of a qualified water treatment specialist should be engaged to determine

what treatment, if any, is required. The product warranty specifically excludes liability for corrosion, erosion or deterioration of equipment.

The heat exchangers and water lines in the units are copper or cupronickel tube. There may be other materials in the buildings piping system that the designer may need to take into consideration when deciding the parameters of the water quality. If antifreeze or water treatment solution is to be used, the designer should confirm it does not have a detrimental effect on the materials in the system.

Contaminated Water

In applications where the water quality cannot be held to prescribed limits, the use of a secondary or intermediate heat exchanger is recommended to separate the unit from the contaminated water. The table above outlines the water quality guidelines for unit heat exchangers. If these conditions are exceeded, a secondary heat exchanger is required. Failure to supply a secondary heat exchanger where needed will result in a warranty exclusion for primary heat exchanger corrosion or failure.

Low Water Coil Limit

Set the freeze sensing switch SW2-1 on the Aurora Base Control (ABC) printed circuit board for applications using a closed loop antifreeze solution to "LOOP" (15°F). On applications using an open loop/ground water system (or closed loop no antifreeze), set this dip switch to "WELL" (30°F), the factory default setting. (Refer to the DIP Switch Settings table in the Aurora Control section.)

General Installation Information cont.

Condensate Drain

On vertical units, the internal condensate drain assembly consists of a drain tube which is connected to the drain pan, a 3/4-inch PVC female adapter and a flexible connecting hose. The female adapter may exit either the front or the side of the cabinet. The adapter should be glued to the field-installed PVC condensate piping. On vertical units, a condensate hose is inside all cabinets as a trapping loop; therefore, an external trap is not necessary.

On horizontal units, a PVC stub is provided for condensate drain piping connection. An external trap is required (see below). If a vent is necessary, an open stand pipe may be applied to a tee in the field-installed condensate piping.

Figure 5: Horizontal Drain Connection

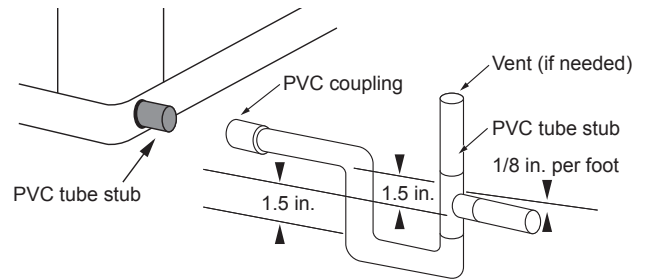

NOTE: Check dimensional data for actual PVC sizes.

Figure 6: Unit Pitch for Drain

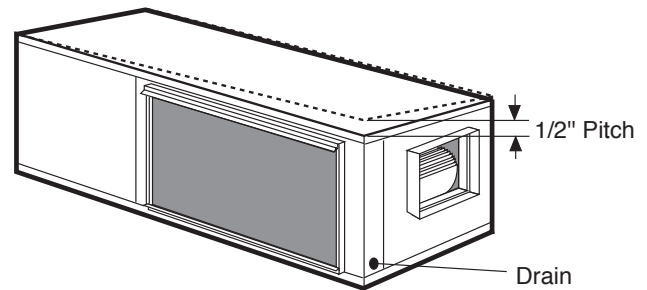

Flow Centers

Pressurized Flow Centers:

- Part numbers: FC1-GL, FC2-GL, FC1-FPT, FC2-FPT, FCV1B-GL, FCV2B-GL
- Used with one or two one or multiple heat pumps on a single loop (need to follow installation manual and install check valves)
- Fixed speed and variable speed pumping available.
- Small footprint for mounting location flexibility.
- Can be mounted in several orientations (see flow center manual for acceptable orientations)
- Injection molded and insulated cabinet
- Brass 3-way valves
- Standard hose kits available

Non-Pressurized Flow Center:

- Part numbers: FC1-GLNP, FC2-GLNP, FCV1B-GLNPP, FCV2B-GLNPP
- Used with a single heat pump on a single loop (or two units if using pump sharing feature). Multiple units cannot be installed in parallel with multiple heat pumps on the same loop.
- Fixed speed and variable speed pumping available.
- Floor mounted (larger footprint than pressurized flow centers)
- Design allows for air and debris separation, and easy fluid checking or addition
- Insulated plastic cabinet
- Composite 3-way valves
- GLNPP flow centers use standard hose kit

Non-Pressurized Dual Circuit Flow Centers:

- Part numbers: FC3-GLNPD, FC4-GLNPD, FCV2AB-GLNPD, FCV2BB-GLNPD, FCV3CB-GLNPD, FCV4AB-GLNPD
- Designed for applications with two geothermal heat pumps by eliminating the need for T's, additional piping, check valves, and pump sharing wiring.
- Multiple pump configurations (fixed and variable speed) to match your flow requirements.
- Insulated sheet metal cabinet
- Brass and composite 3-way valves
- Design allows for air and debris separation, and easy fluid checking or addition
- Floor mounted (larger footprint than pressurized flow centers)
- Standard hose kits available

Closed Loop Ground Source Systems

NOTE: For closed loop systems with antifreeze protection, set SW2-1 to the "LOOP" (15°F) position. (Refer to the DIP Switch Settings table in the Aurora Control section.)

Once piping is completed between the unit, pumps and the ground loop, final purging and charging of the loop is required. A flush cart (or a 1.5 HP pump minimum) is needed to achieve adequate flow velocity in the loop to purge air and dirt particles from the loop itself. A filter **MUST** be used when flushing a loop. The standard 100 micron filter bag (LFC-F100M) is acceptable for capturing relatively large debris such as pipe shavings, gravel, and medium sand particles. In certain installation locations other smaller materials such as fine sand, silt, and clay can be less than 75 microns. For these smaller particles the use of the 1 micron filter bag is required (LFC-F1M). It is also recommended to run the flush cart with the 1 micron filter bag for at least 30 minutes. Antifreeze solution is used in most areas to prevent freezing. Flush the system adequately to remove as much air as possible then pressurize the loop to a static pressure of 40-50 psi (summer) or 50-75 psi (winter). This is normally adequate for good system operation. Loop static pressure will fluctuate with the seasons. Pressures will be higher in the winter months than during the cooling season. This fluctuation is normal and should be considered when initially charging the system.

After pressurization, be sure to turn the venting (burping) screw in the center of the pump two (2) turns open (water will drip out), wait until all air is purged from the pump, then tighten the plug. Ensure that the loop pumps provide adequate flow through the unit(s) by checking the pressure drop across the heat exchanger and comparing it to the unit capacity data in this catalog. 2.5 to 3 gpm of flow per ton of cooling capacity is recommended in earth loop applications.

Figure 7: Closed Loop Ground Source Application

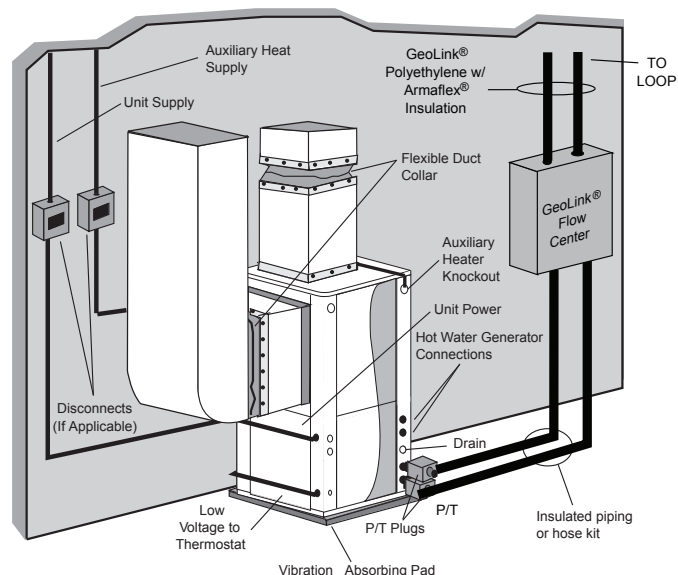

NOTE: Additional information can be found in Flow Center installation manual and Flush Cart manual.

Closed Loop Ground Source Systems cont.

Multiple Units on One Flow Center

When two units are connected to one loop pumping system, pump control is automatically achieved by connecting the SL terminals on connector P2 in both units with 2-wire thermostat wire. These terminals are polarity dependant (see Figure 8). The loop pump(s) may be powered from either unit, whichever is more convenient. If either unit calls, the loop pump(s) will automatically start. The use of two units on one flow center is generally limited to a total of 20 gpm capacity. It is recommended that water solenoid valves be installed on heat pumps that share a flow center. This is to allow water flow through only the heat pump that has a demand. Circulating fluid through a heat exchanger of a system that is not operating could be detrimental to the long term reliability of the compressor.

Variable Speed Pump Setup

When using a variable speed pump flow center (FCV type) the use of an AID Tool will be necessary to adjust minimum and maximum flow rates. The factory default is: minimum=50% and maximum=100% speed levels. See the 7 Series Variable Speed Pump Setup and Modulating Water Valve Setup instructions within the Unit Startup section which is located in the back of this manual. Always ensure that there is adequate flow for the heat pump. See Recommended Minimum/Maximum Flow Rates table.

NOTE: When sharing a flow center, the variable speed heat pump should be the primary unit. When two variable speed heat pumps share a flow center, the larger capacity heat pump should be the primary unit.

Recommended Minimum/Maximum Flow Rates

Model and Size	Closed Loop		Open Loop	
	Min. Flow Rate	Max. Flow Rate	Min. Flow Rate	Max. Flow Rate
	GPM	GPM	GPM	GPM
NV*036	5.0	12.0	5.0	8.0
NV*048	5.0	15.0	5.0	10.0
NV*060	5.0	18.0	5.0	12.0

6/7/12

Figure 8: Primary/Secondary Hook-up

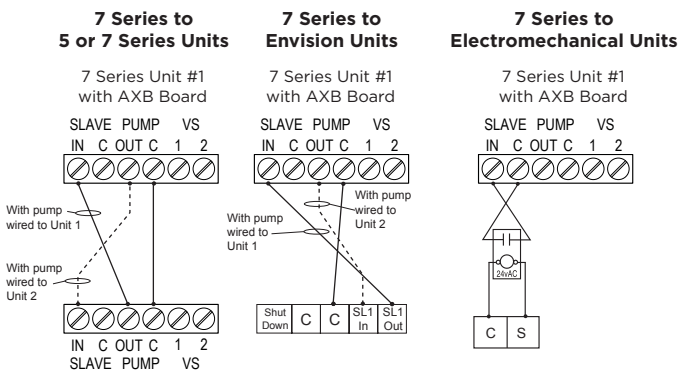

Open Loop Ground Water Systems

Typical open loop piping is shown below. Always maintain water pressure in the heat exchanger by placing water control valves at the outlet of the unit to prevent mineral precipitation. Use a closed, bladder-type expansion tank to minimize mineral formation due to air exposure. Ensure proper water flow through the unit by checking pressure drop across the heat exchanger and comparing it to the figures in unit capacity data tables in the specification catalog. 1.5-2 gpm of flow per ton of cooling capacity is recommended in open loop applications.

Discharge water from the unit is not contaminated in any manner and can be disposed of in various ways, depending on local codes, i.e. recharge well, storm sewer, drain field, adjacent stream or pond, etc. Most local codes forbid the use of sanitary sewer for disposal. Consult your local building and zoning departments to assure compliance in your area. On VS systems, a modulating valve, as shown in figure 9a is the best choice to limit water consumption. The WWKVS well water kit with modulating valve is the recommended setup for open loop applications with variable speed products.

NOTE: For open loop/groundwater systems or systems that do not contain an antifreeze solution, set SW2-Switch #1 to the "WELL" (30°F) position. (Refer to the DIP Switch Settings in the Aurora Control section.) Slow opening/closing solenoid valves (type V) or modulating valves are recommended to eliminate water hammer.

Modulating Water Valve Setup

When using a modulating water valve (23P529-01) the use of an AID Tool will be necessary to adjust minimum and maximum flow rates. The factory default is: minimum=50% and maximum=100% flow levels. It is recommended to start with a minimum setting of 65% and adjust from there if necessary. See the 7 Series Variable Speed Pump Setup and Modulating Water Valve Setup instructions within the Unit Startup section which is located in the back of this manual. See Recommended Minimum and Maximum Flow Rates table. Always ensure that there is adequate flow for the heat pump. A modulating water valve is preferred on variable speed system to conserve water.

Figure 10: Open System - Groundwater Application

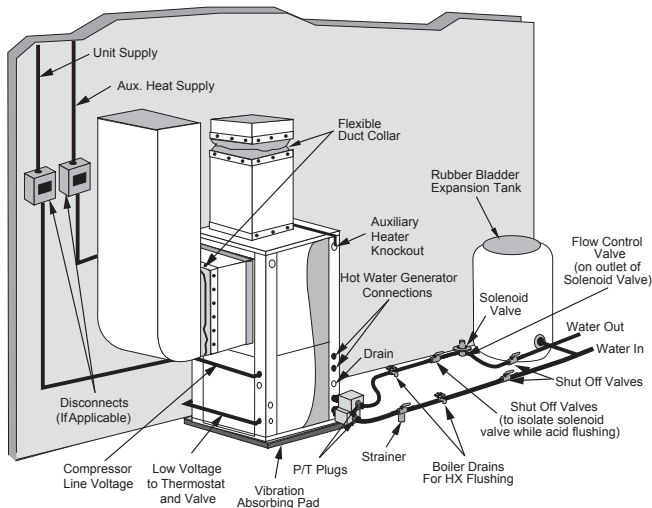

Figure 9a: Modulating Water Valve Connection Option
Typical 0-10VDC modulating water valve.

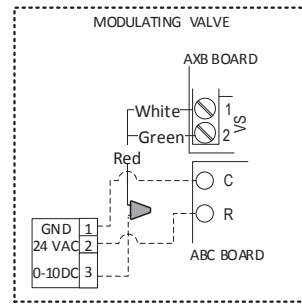

Figure 9b: Open Loop Solenoid Valve Connection Option
Typical slow operating external 24V water solenoid valve (type V) wiring.

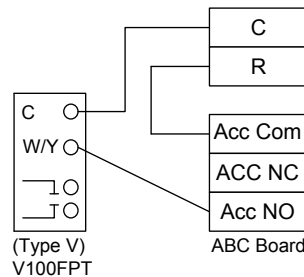
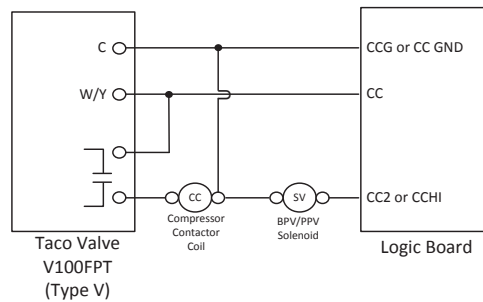
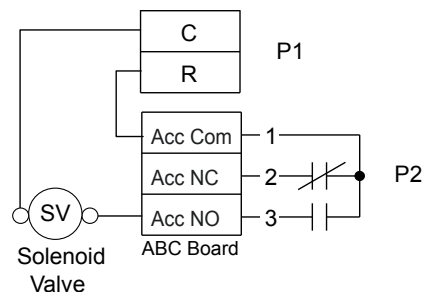

Figure 9c: Wiring diagram for dual water valve installations, one type V slow operating solenoid and one BPV100/PPV100 quick operating solenoid.



Note: SW2-4 should be 'ON' and SW2-5 should be 'OFF'.

Figure 9d: Open Loop Solenoid Valve Connection Option
Typical quick operating external 24V water solenoid valve (type PPV100 or BPV100) wiring.



NOTE: SW2-4 and SW2-5 should be "OFF" to cycle with the compressor.

Hot Water Generator Connections

To maximize the benefits of the hot water generator a minimum 50-gallon water heater is recommended for higher demand applications, use an 80-gallon water heater or two 50-gallon water heaters connected in a series as shown below. Two tanks plumbed in a series is recommended to maximize the hot water generator capability. Electric water heaters are recommended. Make sure all local electrical and plumbing codes are met for installing a hot water generator. Residential units with hot water generators contain an internal circulator and fittings. A water softener is recommended with hard water (greater than 10 grains or 170 total hardness).

NOTES: 1) Using a preheat tank, as shown in Figure 12, will maximize hot water generator capabilities. 2) The hot water generator coil is constructed of vented double wall copper suitable for potable water.

Water Tank Preparation

To install a unit with a hot water generator, follow these installation guidelines.

1. Turn off the power to the water heater.
2. Attach a water hose to the water tank drain connection and run the other end of the hose to an open drain or outdoors.
3. Close the cold water inlet valve to the water heater tank.
4. Drain the tank by opening the valve on the bottom of the tank, then open the pressure relief valve or hot water faucet.
5. Flush the tank by opening the cold water inlet valve to the water heater to free the tank of sediments. Close when draining water is clear.
6. Disconnect the garden hose and remove the drain valve from the water heater.
7. Refer to Plumbing Installation and Hot Water Generator Startup.



CAUTION: Elements will burn out if energized dry.

Figure 11: Typical Hot Water Generator Installation

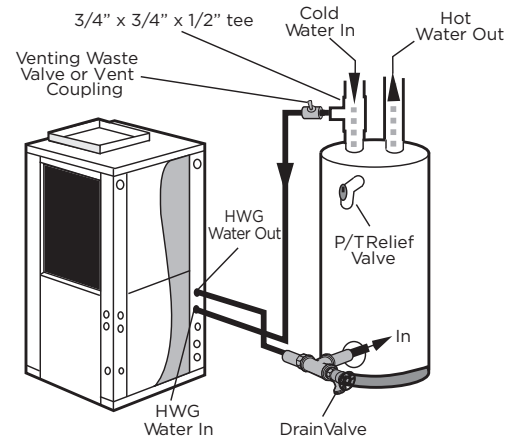
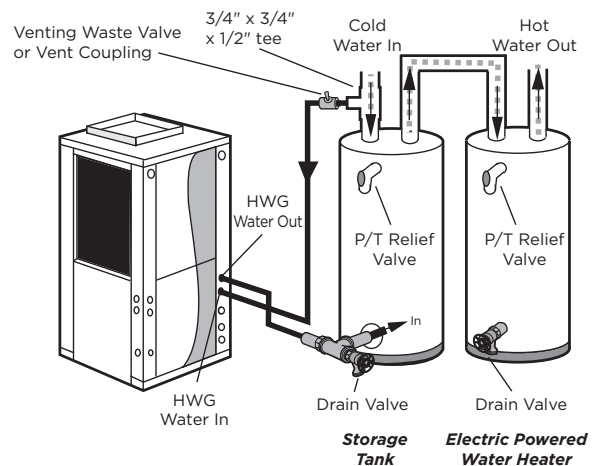

Figure 12: Hot Water Generator Installation In Preheat Tank



NOTE: This configuration maximizes hot water generator capability.

Hot Water Generator Connections cont.

Plumbing Installation

1. Inspect the dip tube in the water heater cold inlet for a check valve. If a check valve is present it must be removed or damage to the hot water generator circulator will occur.
2. Remove drain valve and fitting.
3. Thread the 3/4-inch NPT x 3-1/2-inch brass nipple into the water heater drain port.
4. Attach the center port of the 3/4-inch FPT tee to the opposite end of the brass nipple.
5. Attach the 1/2-inch copper to 3/4-inch NPT adaptor to the side of the tee closest to the unit.
6. Install the drain valve on the tee opposite the adaptor.
7. Run interconnecting tubing from the tee to hot water generator water out.
8. Cut the cold water "IN" line going to the water heater.
9. Insert the reducing solder tee in line with cold water "IN" line as shown.
10. Run interconnecting copper tubing between the unit hot water generator water "IN" and the tee (1/2-inch nominal). The recommended maximum distance is 50 feet.
11. To prevent air entrapment in the system, install a vent coupling at the highest point of the interconnecting lines.
12. Insulate all exposed surfaces of both connecting water lines with 3/8-inch wall closed cell insulation.

NOTE: All plumbing and piping connections must comply with local plumbing codes.

Hot Water Generator Switch

The hot water generator switch is taped in the disabled position at the factory.

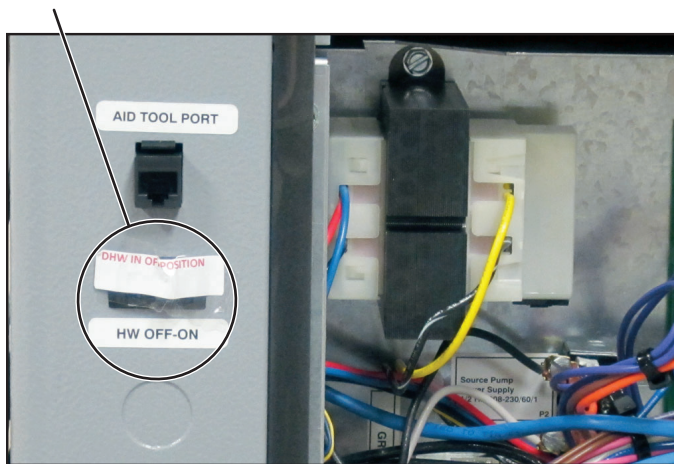

CAUTION: Never operate the HWG circulating pump while dry. If the unit is placed in operation before the hot water generator piping is connected, be sure that the pump switch is set to the OFF position.

Hot Water Generator Startup

1. Turn the hot water generator switch to the "ON" position. The hot water generator switch will allow the hot water generator pump to be enabled or disabled by the service technician or homeowner.
2. Close the drain valve to the water heater.
3. Open the cold water supply to the tank.
4. Open a hot water faucet in the building to bleed air from the system. Close when full.
5. Open the pressure relief valve to bleed any remaining air from the tank, then close.
6. If so equipped, turn the venting (burping) screw in the center of the pump two (2) turns open (water will drip out), wait until all air is purged from the pump, then tighten the plug. Use vent couplings to bleed air from the lines.
7. Carefully inspect all plumbing for water leaks and correct as required.
8. Before restoring electrical supply to the water heater, adjust the temperature setting on the tank.
 - On tanks with both upper and lower elements, the lower element should be turned down to the lowest setting, approximately 100°F. The upper element should be adjusted to 120°F to 130°F. Depending upon the specific needs of the customer, you may want to adjust the upper element differently.
 - On tanks with a single element, lower the thermostat setting to 120°F.
9. After the thermostat(s) is adjusted, replace the access cover and restore electrical supply to the water heater.
10. Make sure that any valves in the hot water generator water circulating circuit are open.
11. Use an AID Tool to enable HWG and select the desired water heating set point. Selectable set points are 100°F - 140°F in 5°F increments (default 130°F). From the Main Menu of the AID Tool select Setup, then AXB Setup.
12. Turn on the unit to first stage heating..
13. The hot water generator pump should be running. When the pump is first started, turn the venting (burping) screw (if equipped) in the center of the pump two (2) turns open until water dribbles out, then replace. Allow the pump to run for at least five minutes to ensure that water has filled the circulator properly. Be sure the switch for the hot water generator pump is "ON".
14. Allow the unit to heat water for 15 to 20 minutes to be sure operation is normal.

Electrical Connections

General

Be sure the available power is the same voltage and phase as that shown on the unit serial plate. Line and low voltage wiring must be done in accordance with local codes or the National Electric Code, whichever is applicable. The compressor has no internal overload. The circuit breaker in the control box is the overload protection for the drive and the compressor. Bypassing the circuit breaker could result in damage to the compressor and voiding the warranty.

Unit Power Connection

Connect the incoming line voltage wires to L1 and L2 of the contactor as shown in Figure 13c for single-phase unit. Consult the Unit Electrical Data in this manual for correct fuse sizes.

Open lower front access panel. Remove ground fastener from bottom of control box (Figure 13b). Swing open control box (Figure 13a). Insert power wires through knockouts on lower left side of cabinet. Route wires through left side of control box and connect to contactor and ground (Figure 13c). Close control box and replace grounding fastener before unit startup.



CAUTION: Frequent cycling of power to the drive can damage the drive! Wait at least 5 minutes between cycles (connecting and disconnecting power to the drive).

Accessory Relay

A set of “dry” contacts has been provided to control accessory devices, such as water solenoid valves on open loop installations, electronic air cleaners, humidifiers, etc. This relay contact should be used only with 24 volt signals and not line voltage power. The relay has both normally open and normally closed contacts and can operate with either the blower or the compressor. Use DIP switch SW2-4 and 5 to cycle the relay with blower, compressor, or control a slow opening water valve. The relay contacts are available on terminals #1 and #3 for normally closed, and on terminals #2 and #3 for normally open on P2.

A second configurable accessory relay is provided on the AXB board. When powering high VA draw components such as electronic air cleaners or VM type open loop water valves, R should be taken ‘pre-fuse’ from the ‘R’ quick connect on the ABC board and not the ‘post-fuse’ ‘R’ terminal on the thermostat connection. If not, blown ABC fuses might result.

208 Volt Operation

All 208/230 units are factory wired for 230 volt operation. For 208 volt operation, the red and blue transformer wires must be switched on terminal strip PS.

Figure 13a:
Wire access (control box open)

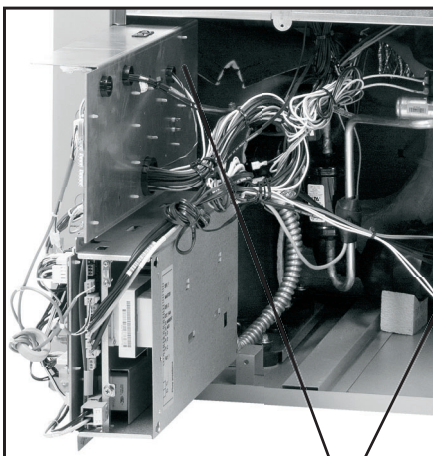

Wire Insert Location

Figure 13b:
Wire access (control box closed)

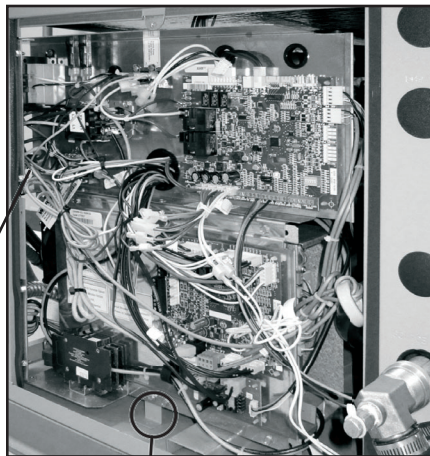

Ground Fastener must be installed for proper unit ground

Figure 13c:
Line Voltage 208-230/60/1 control box

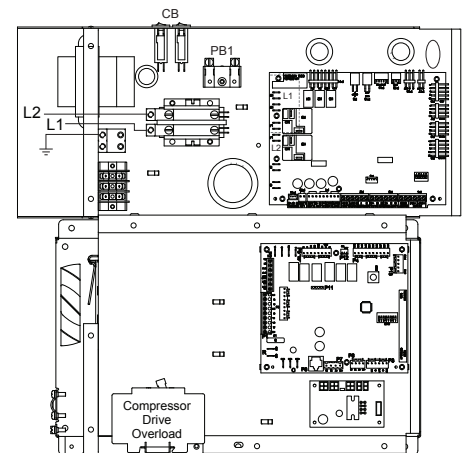

Electrical Connections cont.

Pump Power Wiring

See Figure 14 for electrical connections from control box to pumps.

FC1/FC2 style flow centers with fixed speed pumps connect to PB1 in the control box. If using a variable speed pump it should be connected to L1 and L2 on the AXB.

The UPMXL 25-124 and Magna Geo variable speeds pumps are designed to have power applied to the controls all the time. Applying power to the pump control through a relay to operate as “OFF” and “ON” will be detrimental to the long term reliability of the VS pump.

Figure 14: Pump Wiring 208-230/60/1

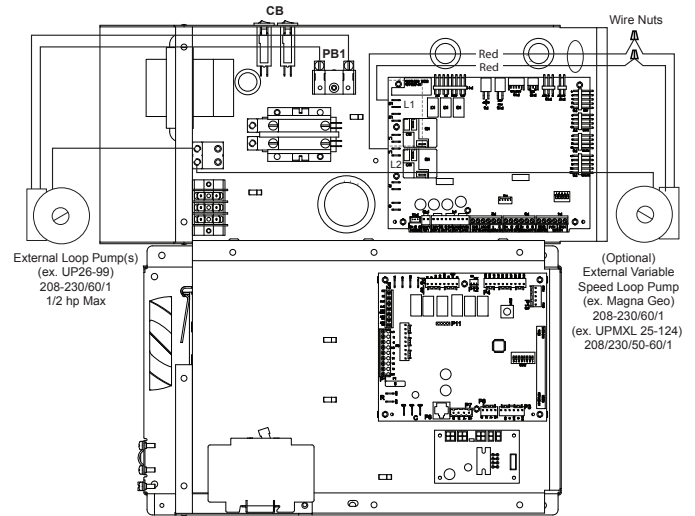

Electrical Information

Fixed Speed Flow Center

The pump(s) will be connected to the terminals on PB1 in the unit electrical box as shown in Figure 3a. The pumps will automatically be cycled as required by the unit or by a signal from another unit sharing the flow center (See Figures 5 and 6). Pumps are protected by circuit breakers (CB) shown in Figure 3a.

Figure 3a: Single/Dual Cap Unit Wiring for Loop Pumps

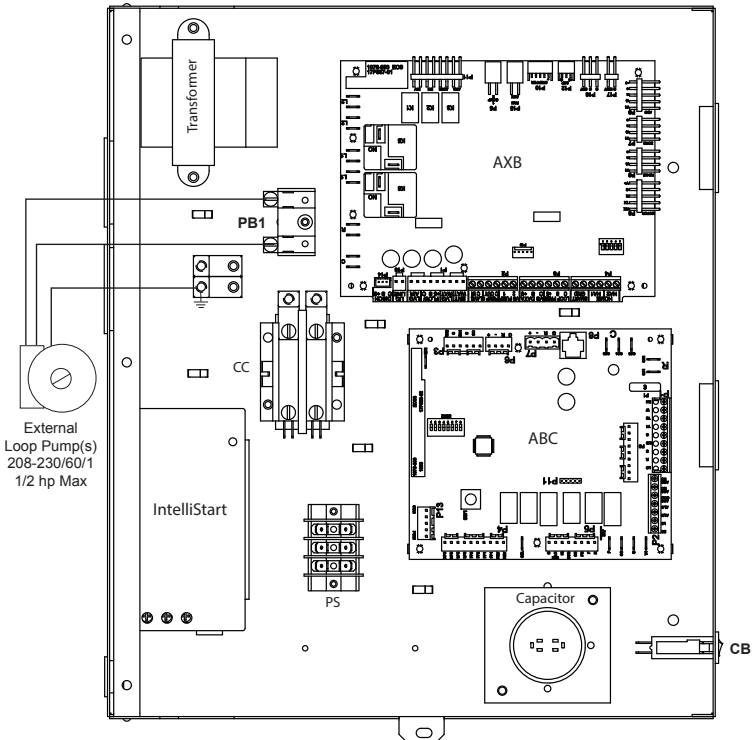

NOTES: For closed loop systems with antifreeze protection, set SW2 DIP Switch #1 to the "Loop" position on units with the Aurora control and SW2-2 should be set to "Loop" on the Premier control.

Figure 3c: FCM and FCL Flow Center Wiring (Not Referenced)

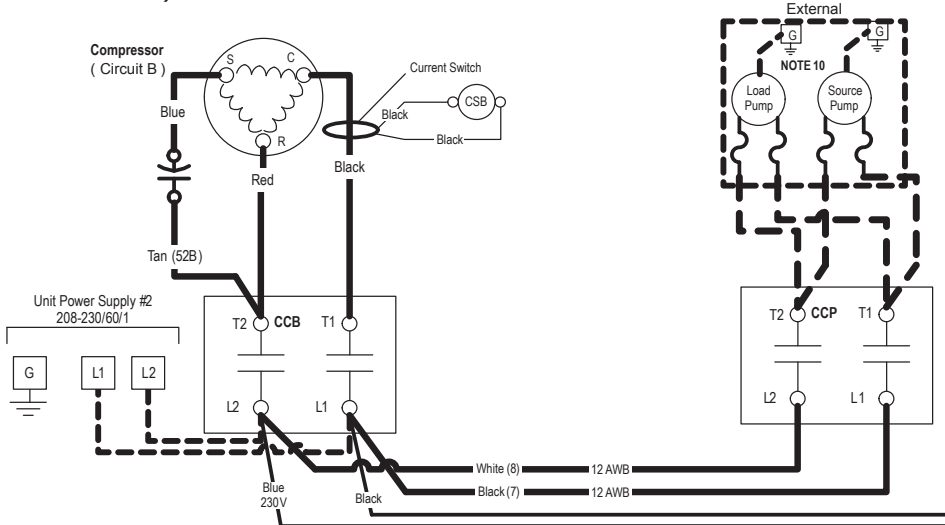

NOTES: FCM and FCL Flow Centers must be wired to a separate contactor (20 amp minimum). The HydroZone Accessory Control Box works best for this application.

Electrical Information cont.

Variable Speed Flow Center

Single Pump Variable Speed Flow Center

If a variable speed single pump flow center is used, the flow center will come with two red and one green wires for the high voltage wiring. The variable speed pump **MUST** be powered at all times and therefore **MUST** be wired to the “L” side of electrical system or damage to the pump will occur (pump cannot be powered from “T” side of compressor contactor). Connect the red HIGH VOLTAGE wires to L1 and L2 on the AXB, connect the green GROUND wire to the ground lug, as shown in figure 4a. Follow all electrical and local codes for wiring.

The variable speed UPMXL 25-124 pump also requires a low voltage signal to operate properly, if the low voltage signal isn't present the pump will run at 100%. Route the low voltage harness connected to the pump to the AXB screw terminals on P2 and P3 connectors per diagram 4b.

Both the low and high voltage harnesses are labeled. The pump will be automatically cycled as required either by the unit or by a signal from another unit sharing the same flow center. Pumps are protected by circuit breakers as shown on the unit schematic.

Figure 4a: Single VS Pump High Voltage Wiring

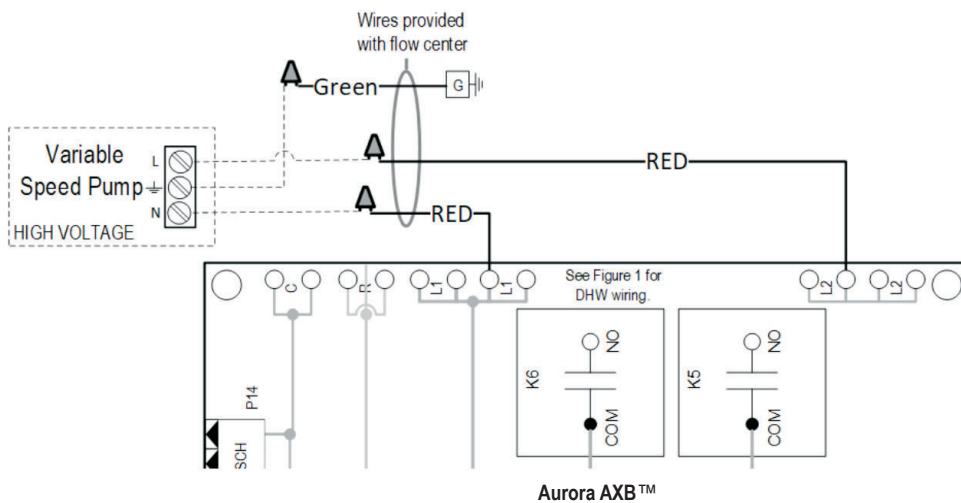
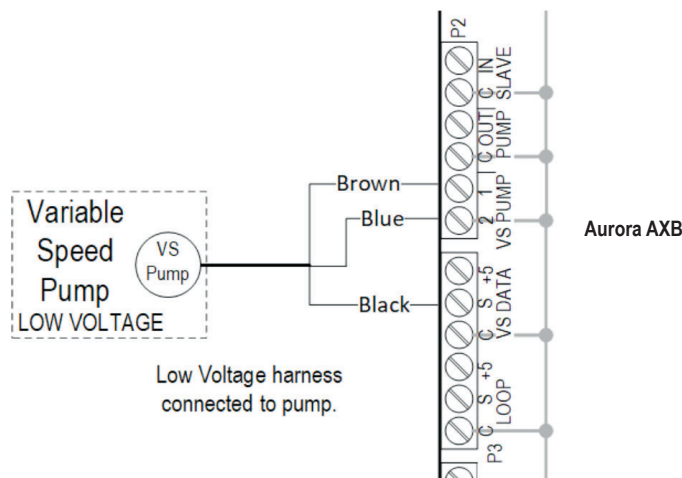

Figure 4b: Single VS Pump Low Voltage Wiring



Note: Aurora AXB must be used to control the UPMXL 25-124 pump.

Electrical Information cont.

Variable Speed Flow Center cont.

Two Pump Variable Speed Flow Center

If a variable speed two pump flow center is used, the flow center will come with four red and two green wires for the high voltage wiring. The second set of (2) red and (1) green wires is provided for installation flexibility. The variable speed pump **MUST** be powered at all times and therefore **MUST** be wired to the “L” side of electrical system or damage to the pump will occur (pump cannot be powered from “T” side of compressor contactor). The UPMXL 25-124 pump has screw terminals for the high voltage connection. Connect the red HIGH VOLTAGE wires to L1 and L2 on the AXB, connect the green GROUND wire to the ground lug, as shown in figure 4d. Follow all electrical and local codes for wiring.

The variable speed UPMXL 25-124 pump also requires a low voltage signal to operate properly, if the low voltage signal isn't present the pump will run at 100%. Route the low voltage harness connected to the right hand pump to the AXB screw terminals on P2 and P3 connectors. Route the low voltage harness connected to the left hand pump to the AXB screw terminals on P2 and P3 connector per figure 4c. The black wire on the left hand pump will have a label on it that reads **“DO NO CONNECT THIS WIRE. ONLY ONE VS PUMP FEEDBACK SIGNAL CAN BE CONNECTED TO AXB BOARD”**.

Both the low and high voltage harnesses are labeled. The pump will be automatically cycled as required either by the unit or by a signal from another unit sharing the same flow center. Pumps are protected by circuit breakers as shown on the unit schematic.

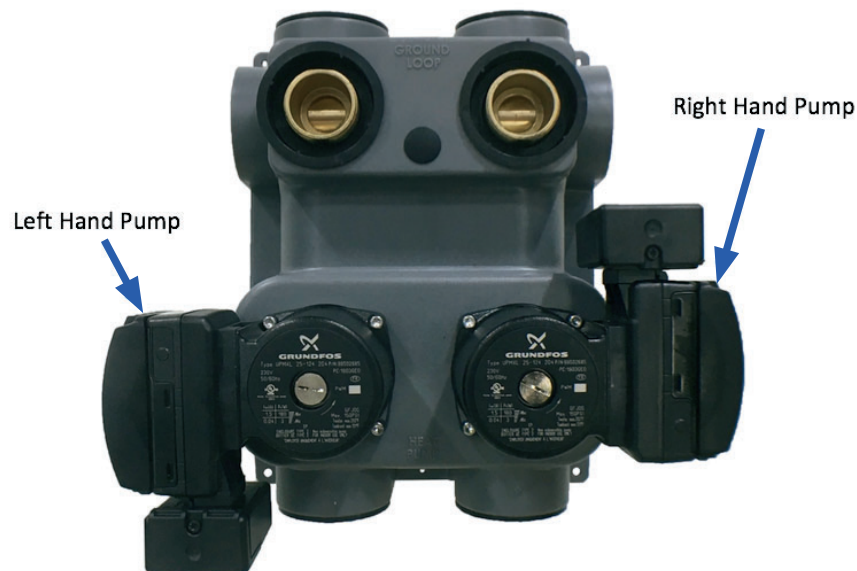

NOTE: Both pumps will speed up and slow down together.

Electrical Information cont.

Variable Speed Units cont.

Two Pump Variable Speed Flow Center cont.

The use of the black wire on the left hand pump is ONLY to be connected for troubleshooting of the pumps. The left hand pump will have a closed end splice connector crimped to the black wire. Cut the closed end splice connector off and strip the wire. During troubleshooting remove the black wire from the right hand pump from the AXB P3 VS DATA S screw terminal and connect the black wire from the left hand pump to the same location. After the troubleshooting is complete remove the black wire from the left hand pump and connect the black wire from the right hand pump.

Place electrical tape or wire nut on the left hand pump black wire. The two pump variable speed flow center cannot have each UPMXL 25-124 pump wired to two separate heat pumps otherwise damage to the pumps will occur (unless it's an NPD Series flow center).

Figure 4c: Two VS Pump Low Voltage Wiring

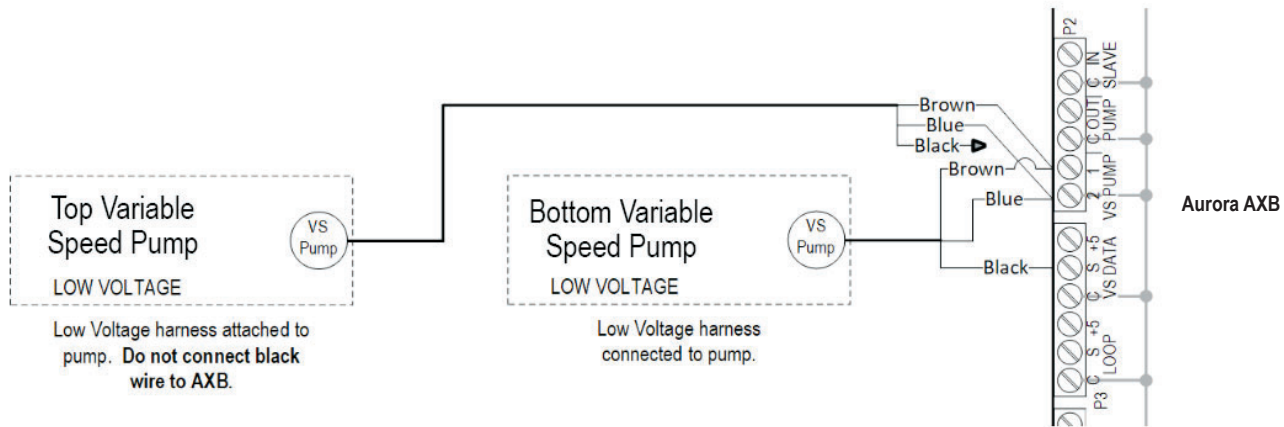

Note: Aurora AXB must be used to control the UPMXL 25-124 pump.

Figure 4d: Two VS Pump High Voltage Wiring

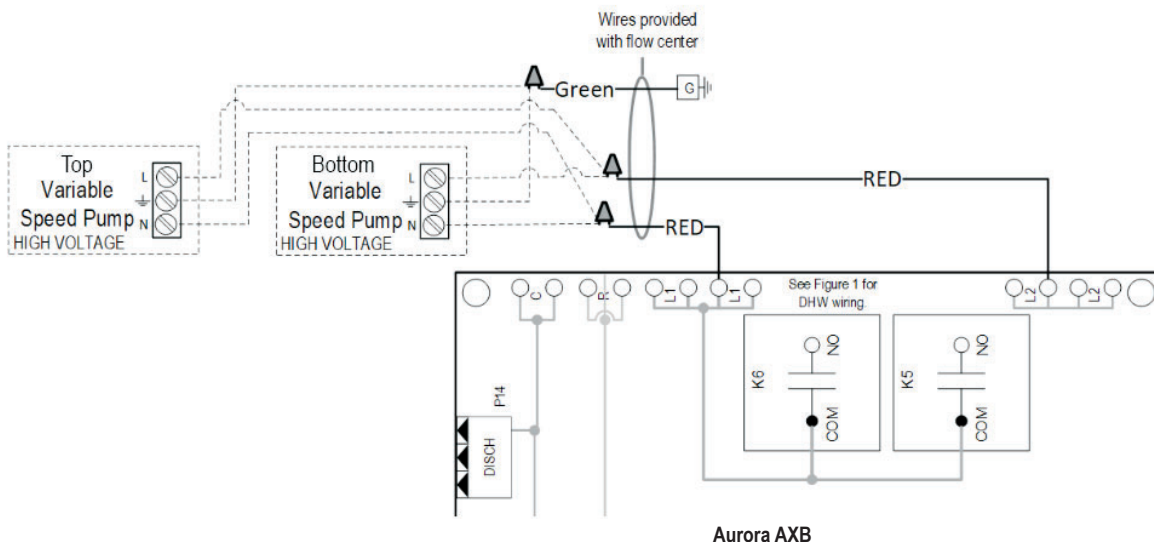

Electronic Thermostat Installation

Position the thermostat subbase against the wall so that it is level and the thermostat wires protrude through the middle of the subbase. Mark the position of the subbase mounting holes and drill holes with a 3/16-inch bit. Install supplied anchors and secure base to the wall. Thermostat wire must be 4-conductor, 20-AWG (minimum) wire. Strip the wires back 1/4-inch (longer strip lengths may cause shorts) and insert the thermostat wires into the connector as shown. Tighten the screws to ensure secure connections. The thermostat has the same type connectors, requiring the same wiring. See instructions enclosed in the thermostat for detailed installation and operation information. The W1 terminal on TPCM32U04A communicating thermostats may be hard wired to provide aux/emergency heat in the event communication is lost between the thermostat and the ABC microprocessor.

Figure 15: Thermostat Wiring (Communicating Style Signals)

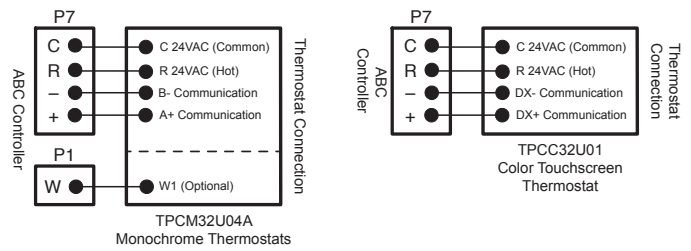

NOTE: If using the IntelliZone2 zoning system, then disregard the diagrams above. The IntelliZone2 system will connect directly to the AXB control board instead. See the IntelliZone2 installation manual for more details.

Auxiliary Heat Ratings

Model	kW		Stages	Btu/h		Min CFM	Model Compatibility		
	208V	230V		208V	230V		036	048	060
EAL(H)10*	7.2	9.6	2	24,600	32,700	1100	•	•	•
EAL(H)15*	10.8	14.4	3	36,900	49,100	1250	•	•	•
EAL(H)20*	14.4	19.2	4	49,200	65,500	1500		•	•

Air flow level for auxiliary heat (Aux) must be above the minimum cfm in this table
Order the "H" part number when installed on horizontal and vertical rear discharge units

11/30/17

Auxiliary Heat Electrical Data

Model	Supply Circuit	Heater Amps		Min Circuit Amp		Max Fuse (USA)		Max Fuse (CAN)		Max CKT BRK	
		208 V	240 V	208 V	240 V	208 V	240 V	208 V	240 V	208 V	240 V
EAL(H)10*	Single	34.7	40	53.3	60	60	60	60	60	60	60
EAL(H)15*	Single	52.0	60	75	85	80	90	80	90	70	100
	L1/L2	34.7	40	53.3	60	60	60	60	60	60	60
	L3/L4	17.3	20	21.7	25	25	25	25	25	20	30
EAL(H)20*	Single	69.3	80	96.7	110	100	110	100	110	100	100
	L1/L2	34.7	40	53.3	60	60	60	60	60	60	60
	L3/L4	34.7	40	43.3	50	45	50	45	50	40	50

All heaters rated single phase 60 cycle and include unit fan load
All fuses type "D" time delay (or HACR circuit breaker in USA)

11/30/17

Electrical Data

Model	Rated Voltage	Voltage Min/Max	Compressor		Drive		HWG Pump FLA	Ext Loop FLA	Blower Motor FLA	Total Unit FLA	Minimum Circuit Amp	Max Fuse HACR Breaker
			LRA	CMCC	RLA	Internal Breaker						
036	208-230/60/1	187/253	10.2	18.0	22.0	30.0	0.4	5.4	4.0	31.8	37.3	40
*036	208-230/60/1	187/253	10.2	18.0	22.0	30.0	0.4	5.4	7.0	34.8	40.3	45
048	208-230/60/1	187/253	12.0	23.5	28.0	35.0	0.4	5.4	7.0	40.8	47.8	50
060	208-230/60/1	187/253	12.0	30.0	33.0	40.0	0.4	5.4	7.0	45.8	54.1	60

*With optional 1 hp Variable Speed ECM Motor
Rated Voltage of 208/230/60/1
HACR circuit breaker in USA only
All fuses Class RK-5

3/26/12

Blower Performance Data

Variable Speed ECM Blower Motor

Model	Air Flow												
	Max ESP	Speed 1	Speed 2	Speed 3	Speed 4	Speed 5	Speed 6	Speed 7	Speed 8	Speed 9	Speed 10	Speed 11	Speed 12
036	0.50	285	380 G	525 L	675	815	980	1100	1220	1330	1440 H	1540 Aux	1575
036 w/1hp*	0.75	480	565 G	665 L	761	870	1000	1100	1200	1300	1410 H	1520 Aux	1630
048	0.75	475	620 G	730 L	850	1020	1140	1270	1400	1520	1650 H	1790 Aux	1925
060	0.75	400	600 G	830 L	1050	1230	1400	1560	1700	1870	2010 H	2140 Aux	2265
**VS Compressor Speed				1-2	3-4		5-6	7-8		9-10	11-12		

** VS Compressor speed is given for the factory default cfm settings. When the cfm default settings are changed it will change the relationship to the compressor speed that is shown in the table. In cooling mode compressor speeds 10-12 are only available when SuperBoost mode is selected at the thermostat. 6/7/12

* Optional 1 hp Variable Speed ECM

Factory settings are at recommended L , H and Aux positions

"G" may be located anywhere within the airflow table

"L" setting should be located within the boldface cfm range

"H" setting MUST be located within the shaded cfm range

"Aux" setting MUST be equal to or greater than "H" setting

"Aux" setting MUST be equal to or greater than the minimum allowable cfm for the auxiliary heater kit (see auxiliary heat ratings table)

Cfm is controlled within 5% up to the maximum ESP

Max ESP includes allowance for wet coil and standard filter

Setting Blower Speed - Variable Speed ECM

The ABC board's Yellow Config LED will flash the current ECM blower speed selections for G, low, and high continuously with a short pause in between. The speeds can also be confirmed with the AID Tool under the Setup/ECM Setup screen. The Aux will not be flashed but can be viewed in the AID Tool. The ECM blower motor speeds can be field adjusted with or without using an AID Tool.

Variable speed ECM Setup without an AID Tool

The blower speeds for G only, Low (Y1), and High (Y2/ Aux) can be adjusted directly at the Aurora ABC board which utilizes the push button (SW1) on the ABC board. This procedure is outlined in the ECM Configuration Mode portion of the Aurora 'Base' Control System section. The Aux cannot be set manually without an AID Tool.

Variable speed ECM Setup with an AID Tool

A much easier method utilizes the AID Tool to change the airflow using the procedure below. First navigate to the Setup screen and then select ECM Setup. This screen displays the current ECM settings. It allows the technician to enter the setup screens to change the ECM settings. Change

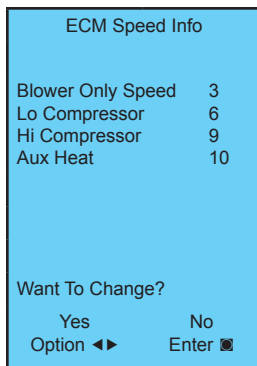

the highlighted item using the ◀ and ▶ buttons and then press the ■ button to select the item.

Selecting YES will enter ECM speed setup, while selecting NO will return to the previous screen.

ECM Speed Setup - These screens allow the technician to select the G, low, high, and auxiliary heat blower speed for the ECM blower motor. Change the highlighted item using the ▲ and ▼ buttons. Press the ■ button to select the speed.

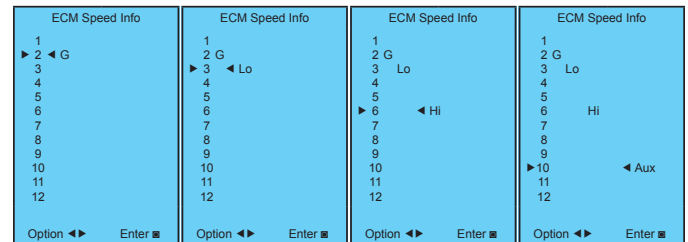

After the auxiliary heat speed setting is selected the AID Tool will automatically transfer back to the ECM Setup screen.

Cooling Airflow Setup - These screens allow the technician to select -15%, -10%, -5%, None or +5% change from the heating airflow. Change the adjustment percentage using the ▲ and ▼ buttons. Press the ■ button to save the change.

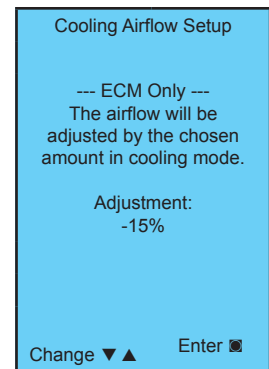
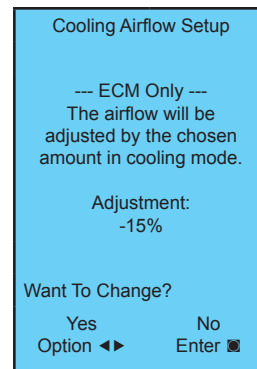

Vertical Dimensional Data

Top Air Discharge

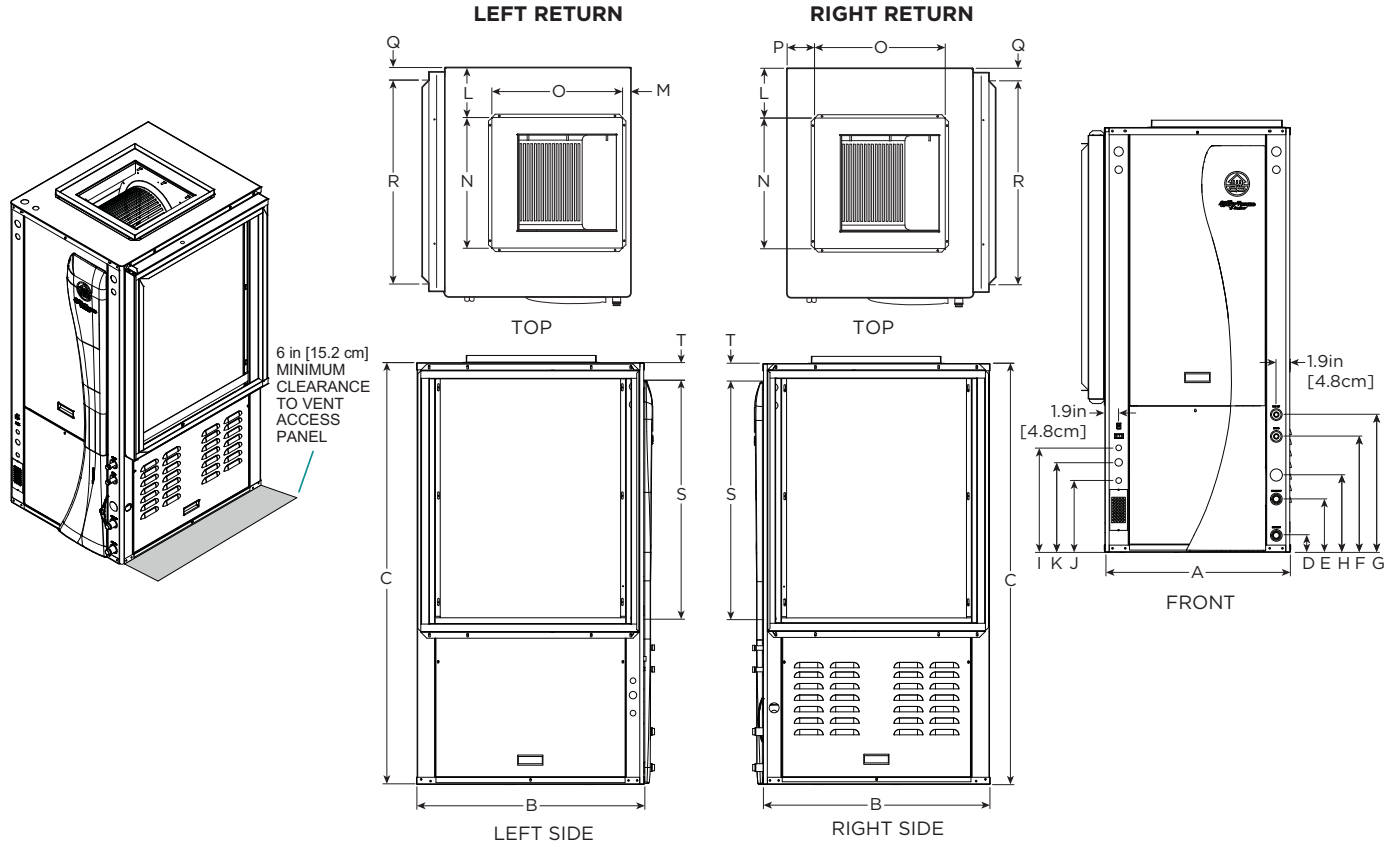

Vertical Top Flow Model	Overall Cabinet			Water Connections						Electrical Connections			Discharge Connection duct flange installed (30.10 in)					Return Connection using std deluxe filter rack (30.10 in)					
	A Width	B Depth	C Height	D Loop In	E Loop Out	F HWG In	G HWG Out	H Condensate	Loop Water FPT	HWG Sweat (I.D.)	I 1/2 in. cond Low Voltage	J 1/2 in. cond Ext Pump	K 3/4 in. cond Power Supply	L	M	N Supply Width	O Supply Depth	P	Q	R Return Depth	S Return Height	T	
036	in.	25.6	31.6	54.4	2.3	7.3	15.9	18.9	10.6	1 in. Swivel	1/2 in. Female	14.3	9.8	12.3	6.9	1.1	18.0	18.0	3.8	1.7	28.1	30.0	1.7
	cm.	65.0	80.3	138.2	5.8	18.5	40.4	48.0	26.9			36.3	24.9	31.2	17.5	2.8	45.7	45.7	9.7	4.3	71.4	76.2	4.3
048	in.	25.6	31.6	54.4	2.3	7.3	15.9	18.9	10.6	1 in. Swivel	1/2 in. Female	14.3	9.8	12.3	6.9	1.1	18.0	18.0	3.8	1.7	28.1	30.0	1.7
	cm.	65.0	80.3	138.2	5.8	18.5	40.4	48.0	26.9			36.3	24.9	31.2	17.5	2.8	45.7	45.7	9.7	4.3	71.4	76.2	4.3
060	in.	25.6	31.6	58.4	2.3	7.3	15.9	18.9	10.6	1 in. Swivel	1/2 in. Female	14.3	9.8	12.3	6.9	1.1	18.0	18.0	3.8	1.7	28.1	34.0	1.7
	cm.	65.0	80.3	148.3	5.8	18.5	40.4	48.0	26.9			36.3	24.9	31.2	17.5	2.8	45.7	45.7	9.7	4.3	71.4	86.4	4.3

Condensate is 3/4 in. PVC female glue socket and is switchable from side to front
 Unit shipped with deluxe 2 in. (field adjustable to 1 in.) duct collar/filter rack extending from unit 3.25 in. and is suitable for duct connection.
 Discharge flange is field installed and extends 1 in. [25.4mm] from cabinet
 Decorative molding and/or water connections extend 1.2 in. [30.5mm] beyond front of cabinet.
 Louvered vents in the compressor section right side access panel extend 1/2 in. [12.7 mm] from side of cabinet. Allow 6" clearance for venting.

6/29/12

Vertical Dimensional Data cont.

Bottom Air Discharge

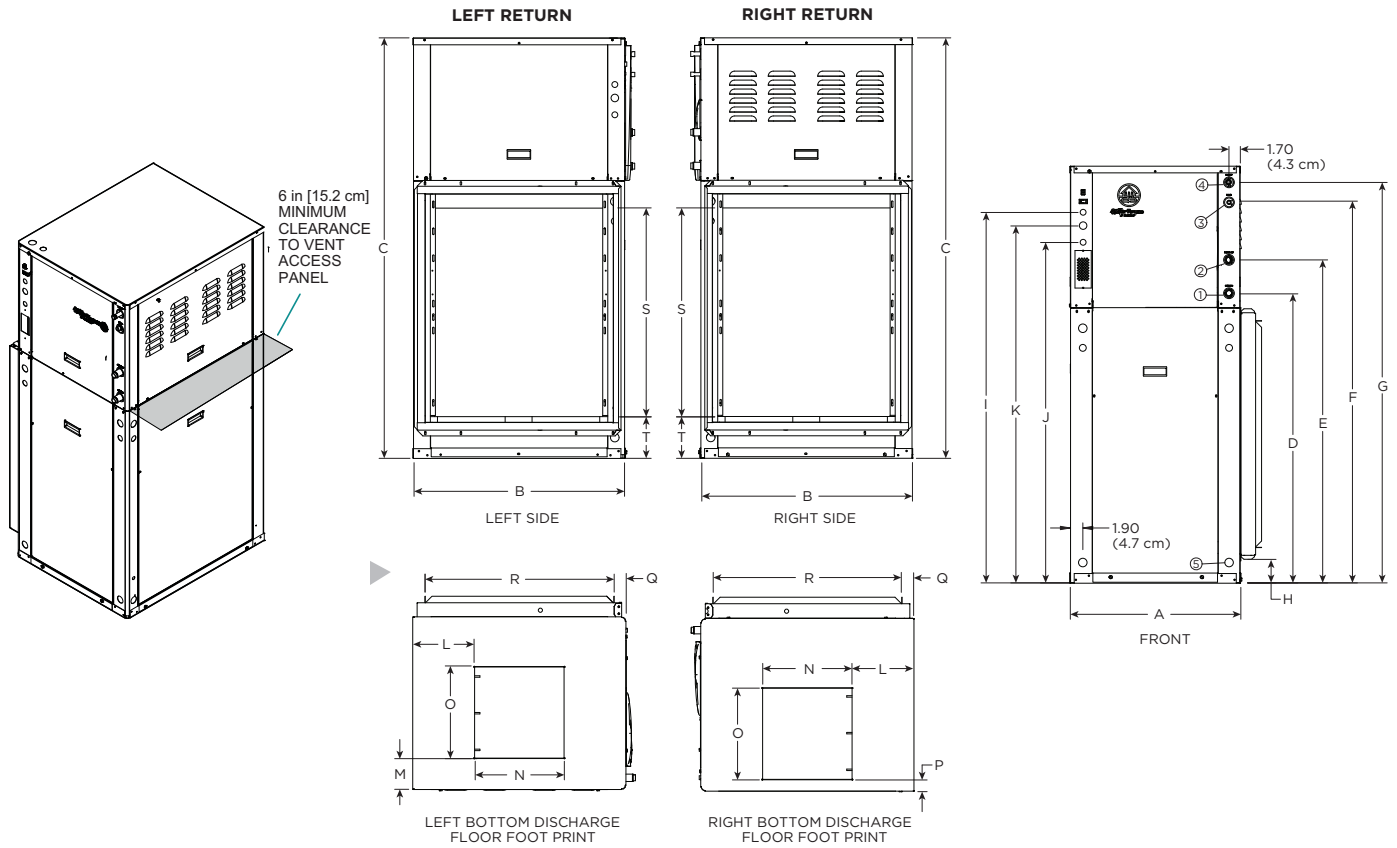

Bottomflow Models	Overall Cabinet			Water Connections							Electrical Knockouts			Discharge Connection duct flange installed (±0.10 in)					Return Connection using std deluxe filter rack (±0.10 in)				
				1	2	3	4	5	Loop Water FPT	HWG Sweat (I.D.)	I 1/2 in. cond	J 1/2 in. cond	K 3/4 in. cond	L	M	N Supply Width	O Supply Depth	P	Q	R Return Depth	S Return Height	T	
	D In	E Out	F HWG In	G HWG Out	H Condensate	Low Voltage	Ext Pump	Power Supply															
036-	in.	25.5	31.5	62.5	43.4	48.4	57.0	60.0	3.1	1 in.	1/2 in.	51.1	55.6	53.6	9.1	4.8	13.4	13.6	1.7	1.8	28.1	34.0	5.6
060	cm.	64.8	80.0	158.8	110.2	122.9	144.8	152.4	7.9	Swivel	Female	129.8	141.2	136.1	23.1	12.2	34.0	34.5	4.3	4.6	71.4	86.4	14.2

Condensate is 3/4 in. PVC female glue socket and is switchable from side to front
 Unit shipped with deluxe 2 in. (field adjustable to 1 in.) duct collar/filter rack extending from unit 3.25 in. and is suitable for duct connection.
 Water connections extend 1.2 in. [30.5mm] beyond front of cabinet.
 Louvered vents in the compressor section right side access panel extend 1/2 in. [12.7 mm] from side of cabinet. Allow 6" clearance for venting.

4/30/12

Vertical Dimensional Data cont.

Rear Air Discharge

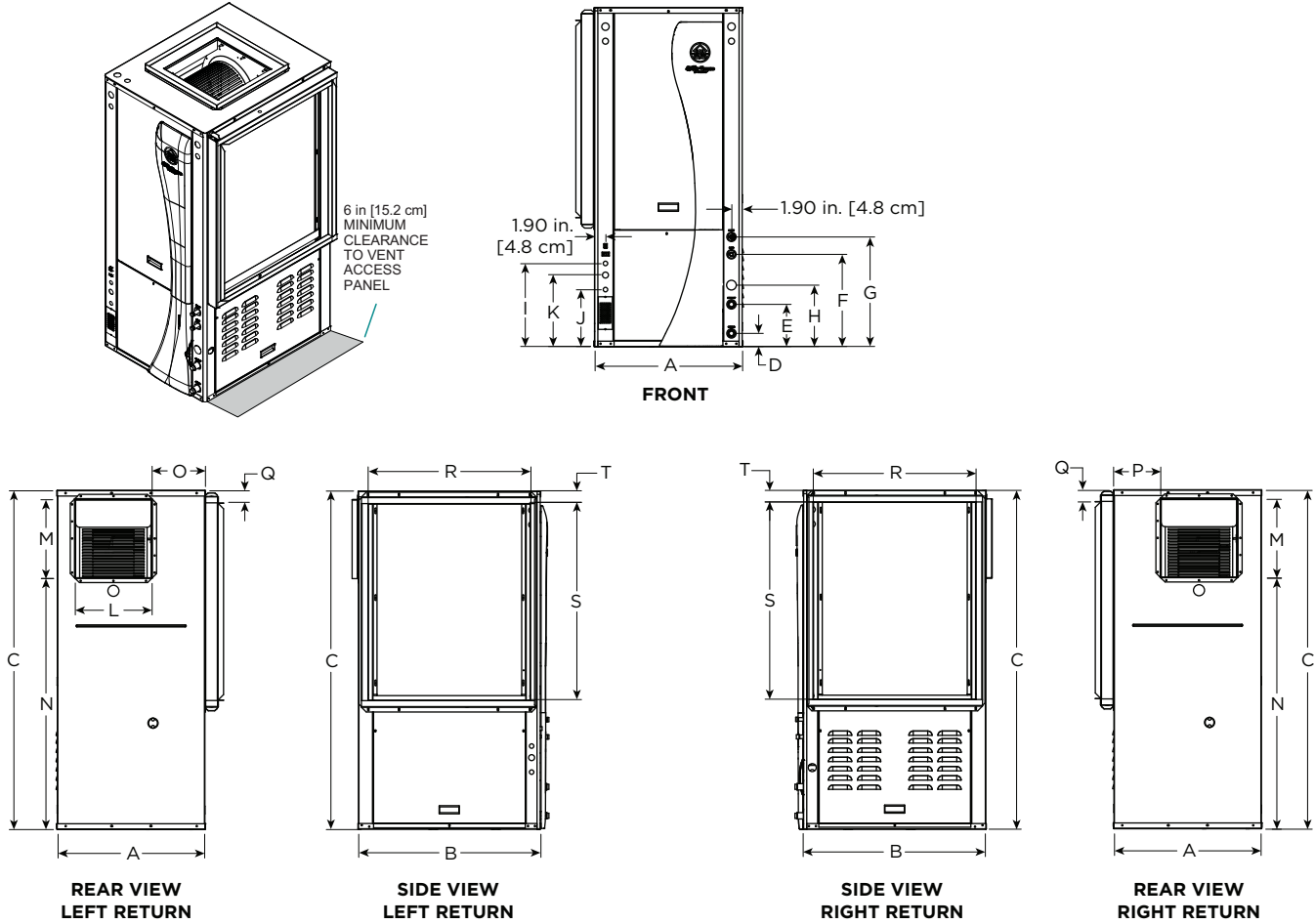

Vertical Rear Discharge Model	Overall Cabinet			Water Connections							Electrical Connections			Discharge Connection duct flange installed (±0.10 in)					Return Connection using std deluxe filter rack (±0.10 in)				
	A Width	B Depth	C Height	D Loop In	E Loop Out	F HWG In	G HWG Out	H Condensate	Loop Water FPT	HWG Sweat (I.D.)	I 1/2 in. cond Low Voltage	J 1/2 in. cond Ext Pump	K 3/4 in. cond Power Supply	L Supply Width	M Supply Depth	N	O	P	Q	R Return Depth	S Return Height	T	
036	in.	25.6	31.6	54.4	2.3	7.3	15.9	18.9	10.6	1 in.	1/2 in.	14.3	9.8	12.3	13.3	13.6	39.4	9.1	8.1	1.7	28.1	30.0	1.7
	cm.	65.0	80.3	138.2	5.8	18.5	40.4	48.0	26.9	Swivel	Female	36.3	24.9	31.2	33.8	34.5	100.1	23.1	20.6	4.3	71.4	76.2	4.3
048	in.	25.6	31.6	54.4	2.3	7.3	15.9	18.9	10.6	1 in.	1/2 in.	14.3	9.8	12.3	13.3	13.6	39.4	9.1	8.1	1.7	28.1	30.0	1.7
	cm.	65.0	80.3	138.2	5.8	18.5	40.4	48.0	26.9	Swivel	Female	36.3	24.9	31.2	33.8	34.5	100.1	23.1	20.6	4.3	71.4	76.2	4.3
060	in.	25.6	31.6	58.4	2.3	7.3	15.9	18.9	10.6	1 in.	1/2 in.	14.3	9.8	12.3	13.3	13.6	43.4	9.1	8.1	1.7	28.1	34.0	1.7
	cm.	65.0	80.3	148.3	5.8	18.5	40.4	48.0	26.9	Swivel	Female	36.3	24.9	31.2	33.8	34.5	110.2	23.1	20.6	4.3	71.4	86.4	4.3

Condensate is 3/4 in. PVC female glue socket and is switchable from side to front
 Unit shipped with deluxe 2 in. (field adjustable to 1 in.) duct collar/filter rack extending from unit 3.25 in. and is suitable for duct connection.
 Discharge flange is field installed and extends 1 in. [25.4mm] from cabinet
 Decorative molding and/or water connections extend 1.2 in. [30.5mm] beyond front of cabinet.
 Louvered vents in the compressor section right side access panel extend 1/2 in. [12.7 mm] from side of cabinet. Allow 6" clearance for venting.

6/29/12

Horizontal Dimensional Data

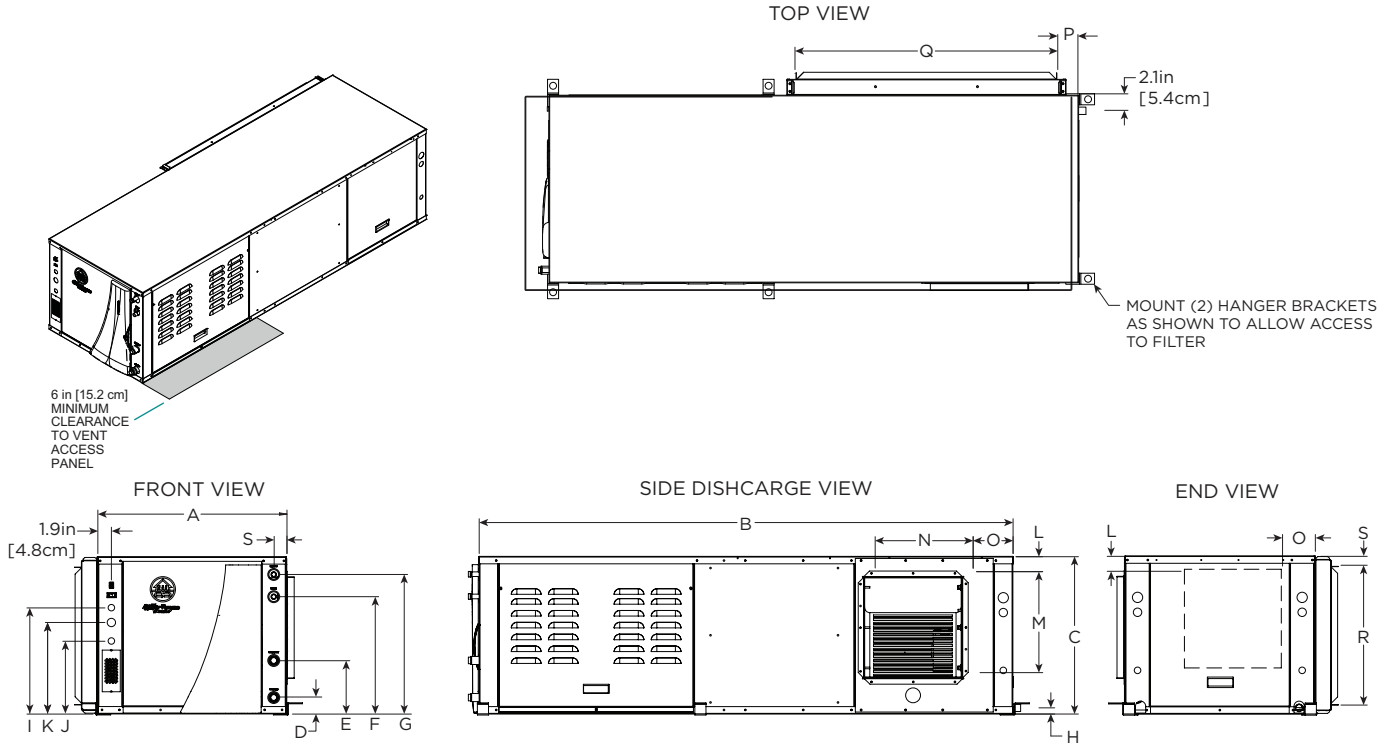

AS SHOWN LR UNIT (RR UNIT ON OPPOSITE SIDE—SAME DIMENSIONS)

Horizontal Models	Overall Cabinet			Water Connections								Electrical Connections			Discharge Connection duct flange installed (±0.10 in)				Return Connection using std deluxe filter rack (±0.10 in)			
	A	B	C	D	E	F	G	H	Loop Water FPT	HWG Sweat (I.D.)	I 1/2 in. cond	J 1/2 in. cond	K 3/4 in. cond	L	M Supply Height	N Supply Depth	O	P	Q Return Depth	R Return Height	S	
	Width	Depth	Height	In	Out	HWG In	HWG Out	Condensate			Low Voltage	Ext Pump	Power Supply									
036	in.	25.6	77.0	21.3	2.3	7.3	15.9	18.9	0.8	1 in. Swivel	1/2 in. Female	14.3	9.8	12.3	SEE CHART	13.6	13.2	SEE CHART	2.8	40.4	18.9	1.3
	cm.	65.0	195.6	54.1	5.8	18.5	40.4	48.0	2.0			36.3	24.9	31.2		34.5	33.5		7.1	102.6	48.0	3.3
048	in.	25.6	77.0	21.3	2.3	7.3	15.9	18.9	0.8	1 in. Swivel	1/2 in. Female	14.3	9.8	12.3	SEE CHART	13.6	13.2	SEE CHART	2.8	40.4	18.9	1.3
	cm.	65.0	195.6	54.1	5.8	18.5	40.4	48.0	2.0			36.3	24.9	31.2		34.5	33.5		7.1	102.6	48.0	3.3
060	in.	25.6	82.0	21.3	2.3	7.3	15.9	18.9	0.8	1 in. Swivel	1/2 in. Female	14.3	9.8	12.3	SEE CHART	13.6	13.2	SEE CHART	2.8	45.4	18.9	1.3
	cm.	65.0	208.3	54.1	5.8	18.5	40.4	48.0	2.0			36.3	24.9	31.2		34.5	33.5		7.1	115.3	48.0	3.3

Condensate is 3/4 in. PVC female glue socket and is switchable from side to front
 Unit shipped with deluxe 2 in. (field adjustable to 1 in.) duct collar/filter rack extending from unit 3.25 in. and is suitable for duct connection.
 Discharge flange is field installed and extends 1 in. [25.4mm] from cabinet
 Decorative molding and/or water connections extend 1.2 in. [30.5mm] beyond front of cabinet.
 Louvered vents in the compressor section right side access panel extend 1/2 in. [12.7 mm] from side of cabinet. Allow 6" clearance for venting.

6/29/12

Units Not Shown Above		L	O
Right Return End Discharge	in	2.8	4.6
	cm	7.1	11.8
Right Return Side Discharge	in	4.9	6.9
	cm	12.4	17.5
Left Return End Discharge	in	4.9	7.6
	cm	12.4	19.4
Left Return Side Discharge	in	2.8	6.9
	cm	7.1	17.5

Physical Data

Model		036	048	060
		Variable Speed Scroll		
Compressor (1 each)				
Factory Charge R410a, oz [kg] (Aluminum tube and fin air coil)	Vertical	90 [2.55]	120 [3.40]	140 [3.96]
Factory Charge R410a, oz [kg] (Aluminum tube and fin air coil)	Horizontal	86 [2.44]	108 [3.06]	148 [4.19]
ECM Blower Motor & Blower				
Blower Motor Type/Speeds	ECM	Variable Speed		
Blower Motor- hp [W]	ECM	1/2 [373]	1 [746]	1 [746]
High Static Blower Motor - hp [W]	ECM	1 [746]	n/a	n/a
Blower Wheel Size (Dia x W), in. [mm]	ECM	11 x 10 [279 x 254]	11 x 10 [279 x 254]	11 x 10 [279 x 254]
High Static Blower Wheel Size - [Dia. x W], in. [mm]	ECM	11 x 10 [279 x 254]	n/a	n/a
Coax and Water Piping				
Water Connections Size - Swivel - in [mm]		1" [25.4]	1" [25.4]	1" [25.4]
HWG Connection Size - Female Sweat I.D. - in [mm]		1/2" [12.7]	1/2" [12.7]	1/2" [12.7]
Coax & Piping Water Volume - gal [l]		1.3 [4.9]	2.3 [8.7]	2.3 [8.7]
Vertical				
Air Coil Dimensions (H x W), in. [mm]		32 x 25 [813 x 635]	32 x 25 [813 x 635]	36 x 25 [914 x 635]
Air Coil Total Face Area, ft2 [m2]		5.6 [0.570]	5.6 [0.570]	6.3 [0.641]
Air Coil Tube Size, in [mm]		3/8 [9.5]	3/8 [9.5]	3/8 [9.5]
Air Coil Number of rows		3	3	4
Filter Standard - 2" [51mm] Pleated MERV11 Throwaway, in [mm]		32 x 30 [813 x 762]	32 x 30 [813 x 762]	36 x 30 [914 x 762]
Weight - Operating, lb [kg]		331 [150]	354 [161]	372 [169]
Weight - Packaged, lb [kg]		351 [159]	374 [170]	392 [178]
Horizontal				
Air Coil Dimensions (H x W), in. [mm]		20 x 40 [508 x 1016]	20 x 40 [508 x 1016]	20 x 4 [508 x 1143]
Air Coil Total Face Area, ft2 [m2]		5.6 [0.570]	5.6 [0.570]	6.3 [0.641]
Air Coil Tube Size, in [mm]		3/8 [9.5]	3/8 [9.5]	3/8 [9.5]
Air Coil Number of rows		3	3	4
Filter Standard - 2" [51mm] Pleated MERV11 Throwaway, in [mm]		1 - 20 x 20 [508 x 508] 1 - 20 x 22 [508 x 559]	1 - 20 x 20 [508 x 508] 1 - 20 x 22 [508 x 559]	1 - 20 x 25 [508 x 635] 1 - 20 x 22 [508 x 559]
Weight - Operating, lb [kg]		365 [166]	388 [176]	402 [182]
Weight - Packaged, lb [kg]		395 [179]	418 [190]	432 [196]

*Bottom flow 036-060 models use the 2in. [51mm] MERV 11 throwaway in. [mm] 36 x 30 [914 x 762] filter.

12/3/2020

The Aurora™ Advanced VS Control System

Aurora Advanced VS Control

Aurora Advanced VS Control System is a complete residential and commercial comfort system that brings all aspects of the HVAC system into one cohesive module network. The Aurora Advanced VS Control features the Aurora Base Control (ABC) and the Aurora Expansion Board (AXB). The variable speed drive communicates to the Aurora Control and provides variable capacity and envelope control. The ABC features microprocessor control and HP, LP, loss of charge, condensate and freeze detection, over/under voltage faults, along with communicating thermostat capability for complete fault detection text at the thermostat. Aurora uses the Modbus communication

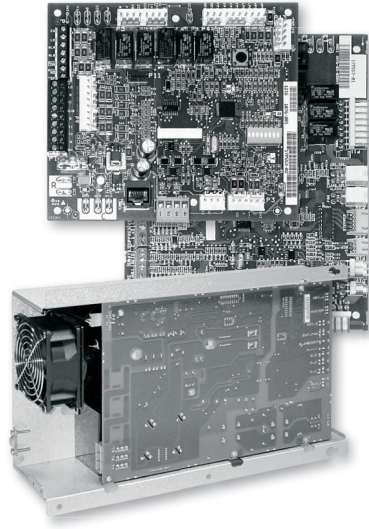

protocol to communicate between modules. Each module contains the logic to control all features that are connected to the module. The ABC has two Modbus channels. The first channel is configured for connecting to devices such as a communicating thermostat, expansion board, or other devices. The second channel is configured for connecting the Aurora Interface Diagnostics Tool (AID Tool).



The Aurora AXB expands on the capability of the ABC control board. The additional features include active dehumidification, SuperBoost cooling mode, loop pump linking, intelligent hot water generator control, variable speed pump capability, standard energy, refrigeration, and optional performance monitoring. The AXB also features an optional second field configurable accessory relay, and two home automation inputs that are AID configurable for different types of alarms from sump pumps to home security. The Smart Grid input is AID configurable with many options to react to Utility controlled relay operation for On Peak optimization. The AXB also expands the communication capability for IntelliZone2 ready operation as well as other expansion with the ClimateTalk protocol.

Aurora Control Features	Description	Aurora Advanced VS
Advanced Microprocessor Features	Smart Grid, Home Automation Alarm Inputs, and Accessory2 Relay (HRV/ERV)	•
Advanced Hot Water Generator Control	Microprocessor and separate power relay for Hot Water Generator Pump with digital temperature monitoring and multiple HWG setpoint selection.	•
Advanced Speed Pump Control	Microprocessor and separate power relay for loop pump and inline circuit breakers and loop pump linking.	•
Variable Speed Pump	Capable of setup, monitoring and controlling a variable speed flow center.	•
Active Dehumidification	Coil temperature is monitored and air flow is reduced for maximum latent moisture removal.	7 Series Variable Speed Only
SuperBoost	Allow the variable speed compressor to ramp up an extra 30% of cooling capacity if needed. This extra 'SuperBoost' will only be available for a 24 hr period and then the unit will revert to normal operation.	•
Smart Grid/Utility Input	Allows simple input to externally enable of occupied/unoccupied mode for basic utility time of use programs.	Dry Contact x1
Home Automation Alarm Input	Allows simple input to signal sump, security, or smoke/CO sensor alarms from other home automation or security systems. The two inputs can be field configured to a number of options and logic.	Dry Contact x2
HAN/Smart Grid Com (AWL and Portal) Kit	Allows direct communication of the Aurora to Smart Meters, Home Automation Network and Internet.	Optional AWL
IntelliZone2® Compatibility	IntelliZone2 communicates to the heat pump via the AXB board.	Optional IntelliZone2

Service Device	Description	Aurora Advanced VS
 <p>Aurora Interface and Diagnostics (AID) Tool</p>	<p>Allows setup, monitoring and troubleshooting of any Aurora Control.</p> <p>NOTE: Although the ABC has basic compatibility with all Aurora, new product features may not be available on older AID Tools. To simplify the basic compatibility ensure the version of AID is at least the same or greater than the ABC software version.</p>	<p>For Service (Ver. 2.xx or greater)</p>

The Aurora Advanced VS Control System cont.

Add On Control Feature Kits (field or factory installed)	Description	Aurora Advanced VS
Geo Energy Monitoring Kit	Monitors real time power consumption of compressor, blower, aux heat and pump. Requires thermostat TPCM32U04A or TPCC32U01.	Standard
Refrigeration Monitoring Kit	Monitors real time pressures, temperatures, superheat, and subcooling.	Standard
Performance Monitoring Kit	Monitors air and water temperatures, and water flow rate and calculates heat of extraction/rejection.	Optional Sensor Kit
Data Logging (AWL) Kit	Allows data logging of up to 12 months. Can also be temporarily installed.	Optional
HAN/Smart Grid Com (AWL and Portal) Kit	Allows direct communication of the Aurora to Smart Meters, HAN, and internet.	Optional

Add On Thermostats and Zoning	Description	Aurora Advanced VS
 <p>TPCM32U04A - MonoChrome Communicating Thermostat</p>	Elite Stat with full English fault codes and alerts, communicating thermostat; Required for viewing Energy Monitoring. Monochrome thermostat allows instantaneous energy measurement only. Compatible with AWL.	Optional
 <p>TPCC32U01 - Color Touchscreen Communicating Thermostat</p>	4.3 in. color touchscreen communicating thermostat with full English fault codes and alerts; Required for viewing Energy Monitoring. Color thermostat allows instantaneous and 13 month history. Compatible with AWL.	Optional
 <p>IntelliZone2® Zoning</p>	Includes color main thermostat and up to 6 zones (with variable speed), 4 zones (with dual capacity), and 2 zones (with single speed). There are 4 thermostat options (MasterStat, SensorStat, SensorStat Remote Kit, ZoneStat). Compatible with AWL. IntelliZone2 is not compatible with UPC controls.	Optional

NOTES: The IntelliZone2 or one of the communicating thermostats shown above must be used to control the variable speed heat pump.

Aurora Advanced VS Control Features

NOTE: Refer to the Aurora Advanced VS Control Application and Troubleshooting Guide and the Instruction Guide: Aurora Interface and Diagnostics (AID) Tool for additional information.

Control Features

Software ABC VS Version 3.02W29 Variable Capacity Compressors

- Random start at power up
- Anti-short cycle protection
- High and low pressure cutouts
- Loss of charge
- Water coil freeze detection
- Air coil freeze detection
- Over/under voltage protection
- Condensate overflow sensor
- Load shed
- Dehumidification (where applicable)
- Emergency shutdown
- Diagnostic LED
- Test mode push button switch
- Two auxiliary electric heat outputs
- Alarm output
- AWL compatible

- Accessory output with N.O. and N.C.
- Modbus communication

Variable Speed ECM Blower Motor

A variable speed ECM blower motor is driven directly using the onboard PWM output. Multiple blower speeds are available based upon requirements of the compressor and electric heat. The blower speeds can be changed either by the variable speed ECM manual configurations mode method or by using the Aurora AID Tool directly.

Advanced Hot Water Generator Control (Domestic Hot Water Option)

An AID Tool selectable temperature limit and microprocessor control of the process is featured. This will maximize hot water generation and prevent undesirable energy use. An alert will occur when the hot water input temperature is at or above the set point (130°F default) for 30 continuous seconds. This alert will appear as an E15 on the AID Tool and the hot water pump de-energizes. Hot water pump operations resume on the next compressor cycle or after 15 minutes of continuous compressor operation during the current thermostat demand cycle. Since compressor hot gas temperature is dependent on

The Aurora Advanced VS Control System cont.

loop temperature in cooling mode, loop temperatures may be too low to allow proper heating of water. The control will monitor water and refrigerant temperatures to determine if conditions are satisfactory for heating water.

VS Drive and Envelope Control

The VS drive operates the compressor between 20 and 100% capacity. The VS drive communicates any out of refrigerant envelope conditions to the Aurora and will attempt to adjust the compressor speed to keep within the envelope. These conditions are measured using the discharge and suction pressure transducers, discharge temperature, and current sensors of the drive.

IntelliZone2 Zoning Compatibility (Optional IntelliZone2 Communicating Zoning)

A dedicated input to connect and communicate with the IntelliZone2 (IZ2) zoning system is provided on P7 on the AXB control board. There is a dedicated communication port using a proprietary ModBus protocol. The AXB is standard on variable speed systems. Consult the IntelliZone2 literature for more information. Not compatible with UPC control option.

Electronic Expansion Valve (EEV)

The electronic expansion valve is operated by the EEV board and is set to maintain optimal superheat setting for maximum efficiency. All operation parameters are communicated to the VS drive and the Aurora system.

AWL - Aurora WebLink (Optional Accessory)

AWL is an add-on WiFi router that connects to the ABC and offers many features:

- Remote access to thermostat settings, schedules, etc. with your smartphone, tablet or laptop.
- Receive Lockout/Fault info via text or email.
- View heat pump energy usage from the internet for the day, week, month, year or real-time.
- Internet AID Tool capability allows remote troubleshooting for the technician.
- Remote AID Tool capability at the heat pump with smartphone, tablet or laptop for the technician.
- Allows data acquisition of the heat pump through the internet, see graphs of performance and chart historical data for the technician.
- Stores historical data on SD card.
- Not compatible with UPC control option

Variable Speed Pump

This input and output are provided to drive and monitor a variable speed pump. The VS pump output is a PWM signal to drive the variable speed pump. The minimum and maximum level are set using the AID Tool. 50% and 100% are the default settings respectively. The VS data input allows a separate PWM signal to return from the pump giving fault and performance information. Fault received from the variable speed pump will be displayed as E16.

Modulating Water Valve

This output is provided to drive a modulating water valve. Through advanced design the 0-10VDC valve can be driven directly from the VS Pump output. The minimum and maximum level are set in the same way as the VS pump using the AID Tool. 50% and 100% are the default settings respectively.

Loop Pump Linking

This input and output are provided so that two units can be linked together with a common flow center. When either unit has a call for loop outputs, both unit's loop pump relays and variable speed pumps are energized. The flow center then can simply be wired to either unit. The output from one unit should be routed to the input of the other. If daisy chained, up to 16 heat pumps can be wired and linked together in this fashion.

Advanced Communication Ports

AXB Communication ports P6 and P8 will provide future expansion via dedicated protocols. These are for future use.

Smart Grid/On Peak (SG) Input

The 'Smart Grid/On Peak' input was designed to allow utilities to utilize simple radio controlled switches to control the On Electric Peak behavior of the 5 and 7 Series Geothermal Heat Pumps and provide demand reduction. With a closed contact signal, this input will limit the operation and thus the power consumption of the unit by disabling the compressor and electric heat as long as the signal is present. Code 7 will flash on the Green LED signifying the 'On Peak' mode. On Peak will also display on communicating thermostats.

Home Automation 1 and 2 Inputs

The Home Automation inputs are simple closed contact inputs that will trigger an AID Tool and thermostat alert for the homeowner. These would require optional sensors and or equipment for connection to the AXB board. With two inputs, two different sensors can be selected. The selected text will then be displayed on the AID Tool and communicating thermostats. These events will NOT alter functionality or operation of the heat pump/accessories and is for homeowner/service notification only.

Home Automation 1 - E23 HA1

With a closed dry contact signal, this input will cause an alarm and Alert Code 23 to indicate on the stat or flash on ABC. The AID Tool will allow configuration of this input between the following selections:

- *No Action*
- *Home Automation Fault* [no lockout info only] - Output from home automation system
- *Security Alarm* [no lockout info only] - Output from home security

The Aurora Advanced VS Control System cont.

- *Sump Alarm Fault* [no lockout info only] - Switch output from sump sensor
- *Smoke/CO Alarm Fault* [no lockout info only] - Switch output from Smoke/CO sensor
- *Dirty Filter Alarm* [no lockout info only] - Output from dirty filter sensor

Home Automation 2 - E24 HA2

With a closed dry contact signal, this input will cause an alarm and Alert Code 24 to indicate on the stat or flash on ABC. The AID Tool will allow configuration of this input between the following selections:

- *No Action*
- *Home Automation Fault* [no lockout info only] - Output from home automation system
- *Security Alarm* [no lockout info only] - Output from home security
- *Sump Alarm Fault* [no lockout info only] - Switch output from sump sensor
- *Smoke/CO Alarm Fault* [no lockout info only] - Switch output from Smoke/CO sensor
- *Dirty Filter Alarm* [no lockout info only] - Output from dirty filter sensor

Monitoring Sensor Kits

Energy Monitoring

(Standard on all 7 Series units)

The Energy Monitoring Kit includes two current transducers (blower and electric heat). The variable speed drive measures compressor drive power so that the complete power usage of the heat pump can be measured. The AID Tool provides configuration detail for the type of blower motor and a line voltage calibration procedure to improve the accuracy. This information can be displayed on the AID Tool or selected communicating thermostats. The TPCM32U04A will display instantaneous energy use while the color touchscreen TPCC32U01 will, in addition, display a 13 month history in graph form.

Refrigerant Monitoring

(Standard)

The optional Refrigerant Monitoring Kit includes two pressure transducers, and three temperature sensors, heating liquid line, suction temperature and existing cooling liquid line (FP1). These sensors allow the measurement of discharge and suction pressures, suction and liquid line temperatures as well as superheat and subcooling. This information will only be displayed on the AID Tool.

Performance Monitoring (Optional)

The Performance Monitoring Kit includes three temperature sensors, entering and leaving water, leaving air temperature and a water flow rate sensor. With this kit heat of extraction and rejection will be calculated. This requires configuration using the AID Tool for selection of water or antifreeze.

Special Modes and Applications

Communicating Digital Thermostats

The Aurora VS controls system also requires either the monochromatic or color touch screen graphic display thermostats for user interface. These displays not only feature easy to use graphical interface but display alerts and faults in plain English.

'SuperBoost' Cooling Mode

Occasionally there can be a requirement for a short term 'boost' of cooling capacity during a large party etc. The 7 Series allows the user to select 'SuperBoost' mode on the thermostat which will allow the 7 Series VS to ramp up an extra 30% of cooling capacity if needed. This extra 'SuperBoost' will only be available for a 24 hr period and then the unit will revert to normal operation. The short term boost does not affect ground loop sizing since it is limited in operation. Continuous use of SuperBoost will result in overheating of the ground loop.

Dehumidification - Active

Active dehumidification will only activate during cooling operation and is based upon the humidity setpoint of the thermostat being at least 5% below the actual relative humidity and being within the temperature parameters described here. The green status LED will flash code 2 when active. The unit can operate a maximum of 1.5°F below the cooling setpoint. The compressor will ramp up and airflow will begin at a low level. Airflow is then reduced periodically until air coil temperature setpoint is reached. If coil temperature continues to drop, the airflow is increased until air coil setpoint is maintained. After 20 minutes of operation in the Active Dehumidification mode, normal cooling operation will resume for 5 minutes. This cycle continues until the dehumidification setpoint is reached, room temperature is more than 1.5°F below cooling setpoint, or more than 1°F above cooling setpoint (normal cooling takes over). In IntelliZone2 systems, active dehumidification is only enabled when system is operating on compressor speeds 4 or lower. Once active dehumidification is activated the main zone and any other active cooling zone will remain open.

Field Hardware Selectable Options

ABC Field Selectable Options via Button (SW1)

Test/Configuration Button (See SW1 Operation Table)

Test Mode

The control is placed in the test mode by holding the push button switch on the ABC SW1 for 2 - 5 seconds. In test mode most of the control timings will be shortened by a factor of sixteen (16). LED3 (green) will flash at 1 second on and 1 second off. Additionally, when entering test mode LED1 (red) will flash the last lockout one time. Test mode will automatically time out after 30 minutes. Test mode can be exited by pressing and holding the SW1 button for 2 to 5 seconds or by cycling the power. **NOTE:** Test mode will automatically be exited after 30 minutes.

The Aurora Advanced VS Control System cont.

Variable Speed ECM Configuration Mode

The control is placed in the variable speed ECM configuration mode by holding the push-button switch SW1 for 5 to 10 seconds, the high, low, and G variable speed ECM speeds can be selected by following the LED display lights. LED2 (yellow) will fast flash when entering the variable speed ECM configuration. When setting G speed LED3 (green) will be continuously lit, for low speed LED1 (red) will be continuously lit, and for high speed both LED3 (green) and LED1 (red) will be continuously lit. During the variable speed ECM configuration mode LED2 (yellow) will flash each of the 12 possible blower speeds 3 times. When the desired speed is flashed press SW1, LED2 will fast flash until SW1 is released. G speed has now been selected. Next select low speed, and high speed blower selections following the same process above. After third selection has been made, the control will exit the variable speed ECM configuration mode. Aux blower speed will remain at default or current setting and requires the AID Tool for adjustment.

Reset Configuration Mode

The control is placed in reset configuration mode by holding the push button switch SW1 on the ABC for 50 to 60 seconds. This will reset all configuration settings and the EEPROM back to the factory default settings. LED3 (green) will turn off when entering reset configuration mode. Once LED3 (green) turns off, release SW1 and the control will reset.

ABC DIP Switch (SW2)

- SW2-1** FP1 Selection – Low water coil temperature limit setting for freeze detection. On = 30°F; Off = 15°F.
- SW2-2** FP2 Selection – Low air coil temperature limit setting for freeze detection. On = 30°F; Off = Not Used
- SW2-3** RV – O/B - thermostat type. Heat pump thermostats with “O” output in cooling or “B” output in Heating can be selected. On = O; Off = B.
- SW2-4** Access Relay Operation (P2)
and 2-5

Access Relay Operation	SW2-4	SW2-5
Cycle with Blower	ON	ON
Cycle with Compressor	OFF	OFF
Water Valve Slow Opening	ON	OFF
Cycle with Comm. T-stat Hum Cmd	OFF	ON

- SW2-6** CC Operation – selection of single or dual capacity compressor. On = Single Stage; Off = Dual Capacity
NOTE: SW2-6 is not applicable to the 7 Series
- SW2-7** Lockout and Alarm Outputs (P2) – selection of a continuous or pulsed output for both the LO and ALM Outputs. On = Continuous; Off = Pulsed
NOTE: SW2-7 is not applicable to the 7 Series
- SW2-8** Future Use

Alarm Jumper Clip Selection

From the factory, ALM is connected to 24 VAC via JW2. By cutting JW2, ALM becomes a dry contact connected to ALG.

Variable Speed ECM Blower Speeds

The blower speeds can be changed either by using the variable speed ECM manual configurations mode method or by using the Aurora AID Tool directly (see Instruction Guide: Aurora Interface and Diagnostics (AID) Tool topic).

AXB DIP Switch (SW1)

DIP 1 - ID: This is the AXB ModBus ID and should always read On.

DIP 2 & 3 - Future Use

DIP 4 & 5 - Accessory Relay2: A second, DIP configurable, accessory relay is provided that can be cycled with the compressor 1 or 2, blower, or the Dehumidifier (DH) input. This is to complement the Accessory 1 Relay on the ABC board.

Position	DIP 4	DIP 5	Description
1	ON	ON	Cycles with blower or ECM (or G)
2	OFF	ON	Cycles with CC1 first stage of compressor or compressor spd 1-12
3	ON	OFF	Cycles with CC2 second stage of compressor or compressor spd 7-12
4	OFF	OFF	Cycles with DH input from ABC board

Field Selectable Options via Software (Selectable via the Aurora AID Tool)

Many options are field selectable and configurable in Aurora software via the AID Tool. Consult the installation manual or Aurora documentation for further details.

Basic Aurora Safety Features

The following safety features are provided to protect the compressor, heat exchangers, wiring and other components from damage caused by operation outside of design conditions.

Fuse – a 3 amp automotive type plug-in fuse provides protection against short circuit or overload conditions. Anti-Short Cycle Protection – 4 minute anti-short cycle protection for the compressor.

Random Start – 5 to 80 second random start upon power up.

Fault Retry – in the fault condition, the control will stage off the outputs and then “try again” to satisfy the thermostat VS call. Once the thermostat input calls are satisfied, the control will continue on as if no fault occurred. If 3 consecutive faults occur without satisfying the thermostat VS call, then the control will go to Lockout mode.

The Aurora Advanced VS Control System cont.

Lockout - when locked out, the blower will operate continuously in "G" blower speed setting. The Alarm output (ALM) and Lockout output (L) will be turned on. The fault type identification display LED1 (Red) shall flash the fault code. To reset lockout conditions with SW2-8 On, the demand call must be removed for at least 30 seconds. To reset lockout conditions with SW2-8 Off, the demand call must be removed for at least 30 seconds. Lockout may also be reset by turning power off for at least 30 seconds or by enabling the emergency shutdown input for at least 30 seconds.



CAUTION: Frequent cycling of power to the drive can damage the drive! Wait at least 5 minutes between cycles (connecting and disconnecting power to the drive).

Lockout With Emergency Heat - if the control is locked out in the heating mode, and a call for emergency heat is received, the control will operate in the emergency heat mode while the compressor is locked out. The first emergency heat output will be energized 10 seconds after the W input is received, and the blower will shift to high speed. If the control remains locked out, and the W input is present, additional stage of emergency heat will stage on after 2 minutes. When the W input is removed, all of the emergency heat outputs will turn off, and the variable speed ECM blower will shift to low speed.

High Pressure - fault is recognized when the Normally Closed High Pressure Switch, P4-9/10 opens, no matter how momentarily. The High Pressure Switch is electrically in series with the Compressor Contactor and serves as a hardwired limit switch if an overpressure condition should occur.

Low Pressure - fault is recognized when the Normally Closed Low Pressure Switch, P4-7/8 is continuously open for 30 seconds. Closure of the LPS any time during the 30 second recognition time restarts the 30 second continuous open requirement. A continuously open LPS shall not be recognized during the 2 minute startup bypass time.

Loss of Charge - fault is recognized when the Normally Closed Low Pressure Switch, P4-7/8 is open prior to the compressor starting.

Condensate Overflow - fault is recognized when the impedance between this line and 24 VAC common or chassis ground drops below 100K ohms for 30 seconds continuously.

Freeze Detection-Coax - set points shall be either 30°F or 15°F. When the thermistor temperature drops below the selected set point, the control shall begin counting down the 30 seconds delay. If the thermistor value rises above the selected set point, then the count should reset. The resistance value must remain below the selected set

point for the entire length of the appropriate delay to be recognized as a fault. This fault will be ignored for the initial 2 minutes of the compressor run time.

Freeze Detection-Air Coil - Air Coil Freeze Detection will use the FP2 input to protect against ice formation on the air coil. The FP2 input will operate exactly like FP1 except that the set point is 30 degrees and is not field adjustable.

Over/Under Voltage Shutdown - An over/under voltage condition exists when the control voltage is outside the range of 18 VAC to 30 VAC. If the over/under voltage shutdown lasts for 15 minutes, the lockout and alarm relay will be energized. Over/under voltage shutdown is self-resetting in that if the voltage comes back within range of 18 VAC to 30 VAC for at least 0.5 seconds, then normal operation is restored.

Other Lockouts and Alarms

Several other lockouts and alarms are shown in the Status LED1 (LED1, Red) table with the associated codes visible on the thermostat, ABC Fault LED, and in text in the AID Tool.

Operation Description

Power Up - The unit will not operate until all the inputs and safety controls are checked for normal conditions. The unit has a 5 to 80 second random start delay at power up. Then the compressor has a 4 minute anti-short cycle delay after the random start delay.

Standby - In standby mode the compressor, pump, and blower motor are not active. The RV may be active. The blower and compressor will be off.

Heating Operation - The unit will operate based upon demand as calculated by the room setpoint algorithm. The resulting compressor speed (1-12) will also select an appropriate blower speed for the selected compressor speed. Aux Heat will not be available (on IntelliZone2 Aux Heat is available on compressor speeds 10-12) until after the 12th compressor speed has been operational and still is not satisfying the thermostat, then auxiliary electric heat will be activated.

Emergency Heat (W) - The blower will be started on G speed, 10 seconds later the first stage of electric heat will be turned on. 5 seconds after the first stage of electric heat is energized the blower will shift to Aux speed. If the emergency heat demand is not satisfied after 2 minutes the second electric heat stage will be energized.

Cooling Operation - The unit will operate based upon demand as calculated by the room setpoint algorithm. The resulting compressor speed, speeds 1-9, (speeds 10-12 are reserved for SuperBoost mode only) will also select

The Aurora Advanced VS Control System cont.

an appropriate blower speed. The blower mode will also have the cooling airflow adjustment applied. In all cooling operations, the reversing valve directly tracks the O input. Thus, anytime the O input is present, the reversing valve will be energized.

Blower (G) - The blower will start immediately upon receiving a thermostat G command. If there are no other commands from the thermostat the variable speed ECM will run on low speed until the G command is removed. Regardless of blower input (G) from the thermostat, the blower will remain on low speed for 30 seconds at the end of each heating, cooling, and emergency heat cycle.

Emergency Shutdown - Four (4) seconds after a valid ES input, P2-7 is present, all control outputs will be turned off and remain off until the emergency shutdown input is no longer present. The first time that the compressor is started after the control exits the emergency shutdown mode, there will be an anti-short cycle delay followed by a random start delay. Input must be tied to common to activate.

Continuous Blower Operation - The blower output will be energized any time the control has a G input present, unless the control has an emergency shutdown input present. The blower output will be turned off when G input is removed.

Load Shed - The LS input disables all outputs with the exception of the blower output. When the LS input has been cleared, the anti-short cycle timer and random start timer will be initiated. Input must be tied to common to activate.

Aurora Advanced VS Control LED Displays

These three LEDs display the status, configuration, and fault codes for the control. These can also be read in plain English via the Aurora AID Tool. See the LED tables for further explanation.

Aurora Interface and Diagnostics (AID) Tool

The Aurora Interface and Diagnostics (AID) Tool is a device that is a member of the Aurora network. The AID Tool is used to troubleshoot equipment which uses the Aurora control via Modbus RTU communication. The AID Tool provides diagnostics,



fault management, variable speed ECM setup, and system configuration capabilities to the Aurora family of controls. An AID Tool is recommended, although not required, for variable speed ECM airflow settings. The AID Tool simply plugs into the exterior of the cabinet in the AID Tool port.

Aurora Contractor Connect and Symphony Contractor Connect (Coming Soon!)

The Symphony Contractor Connect (SCC) brings WaterFurnace ground source heat pump data and troubleshooting to your fingertips. Symphony Contractor Connect with the use of the Aurora Contractor Connect (ACC) replaces the current AID Tool. This app provides an enhanced and more efficient experience for the service technician in assessing system performance and component troubleshooting. REQUIRES WaterFurnace dealer login credentials SCC is for WaterFurnace dealer technicians ONLY and includes:

- AID Tool
- Technical Literature lookup
- Troubleshooting videos
- Step by Step AWL Setup and Configuration to Home Router
- Methodical approach to assist in diagnostics
- Perform routine installation chart reading and calculations
- Electronic capture of Start-Up Documentation
- Active Charge Assist and Charge Calculator for split systems



Status LED (LED3, Green)





Description of Operation	Fault LED, Green
Normal Mode	ON
Control is Non-functional	OFF
Test Mode	Slow Flash
Lockout Active	Fast Flash
Dehumidification Mode	Flash Code 2
Load Shed	Flash Code 5
Emergency Shutdown	Flash Code 6
On Peak Mode	Flash Code 7
Warning! VS Derated	Flash Code 8
Warning! VS SafeMode	Flash Code 9

Configuration LED (LED2, Yellow)

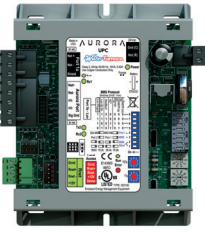
Description of Operation	Configuration LED, Yellow
No Software Overwritten	ECM Setting
DIP Switch Overwritten	Slow Flash
ECM Configuration Mode	Fast Flash
Reset Configuration Mode	OFF

The Aurora Advanced VS Control System cont.

<p>Aurora Control w/UPC BACnet</p> 	<p>The Aurora Unitary Protocol Converter (UPC) is an integrated solution and communicates directly with the Aurora Heat Pump Controls and allows access/control of a variety of internal Aurora Heat pump operations such as sensors, relay operation, faults and other information. In turn, the UPC then converts internal Aurora Modbus protocol to BACnet MS/TP protocol and communicates to the HAS system. This provides the great benefit of complete control integration and a myriad of information available to the HAS from the heat pump control. Plus it also allows individual unit configuration such as ECM fan speeds or freeze protection setting directly over the HAS without the need for access to the actual heat pump.</p>	<p>The Aurora UPC is implemented with the Aurora Base Controller (ABC) heat pump control into our latest water source heat pumps. All internal Aurora points are accessible to the UPC via firmware providing an integrated solution. All zone temperatures and zone sensors are connected to the UPC on an RNet bus, simplifying hook up at the unit. RNet sensors can include a combination of zone temperature and humidity, CO2, and VOC sensors. The UPC includes built-in support for a custom configurable keypad/display unit.</p>	<p>Optional Equipment Touch Display</p>	<p>BACnet MS/TP</p>
---	--	--	---	---------------------

UPC Sensors & Thermostats	Description	Aurora 'Base'	Aurora 'Base'	Aurora 'Advanced'
<p>ZS Standard</p> 	<p>Local access port /No user control</p>	<p>Optional</p>	<p>Optional</p>	<p>Optional</p>
<p>ZS Plus</p> 	<p>Local access port/Slide potentiometer to make the zone warmer or cooler /Control button to override the schedule and put the zone in an occupied state, or force the zone to an unoccupied state/Green LED to Indicate occupied state.</p>	<p>Optional</p>	<p>Optional</p>	<p>Optional</p>
<p>ZS Pro</p> 	<p>Local access port/LED display/Control button to override the schedule and put the zone in an occupied state, or force the zone to an unoccupied state/Arrow UP and DOWN buttons to change any editable property, such as the setpoint temperature/button to cycle through information defined in the control program/Green LED to Indicate occupied state.</p>	<p>Optional</p>	<p>Optional</p>	<p>Optional</p>
<p>ZS Pro-F</p> 	<p>Local access port/LED display/Control button to override the schedule and put the zone in an occupied state, or force the zone to an unoccupied state/Arrow UP and DOWN buttons to change any editable property, such as the setpoint temperature/button to cycle through information defined in the control program/Green LED to Indicate occupied state/Mode button to turn on heating, cooling, or fan only, or to set auto control/ Fan button to adjust fan speed/ F/C button to set temperature to Fahrenheit of Celsius</p>	<p>Optional</p>	<p>Optional</p>	<p>Optional</p>

NOTE: A ZS type sensor/thermostat is necessary for compatibility with UPC.

Aurora UPC

An optional Aurora UPC for DDC applications communicates directly with the entire Aurora system and provides DDC protocol of BACnet MS/TP for connection to the HAS providing a wide variety of points covering configurations, sensors, airflow and freeze protection. For more information on the Aurora UPC, please consult the Aurora UPC Application Guide for Variable Speed Applications.

NOTE: The UPC is not compatible with IntelliZone2 or Symphony.

Aurora Touch Interface

Utilizing the service technicians personal Android tablet (Android 4.0 or higher) along with Equipment Touch App (purchased from the Play Store) and our Aurora Touch Cable (part number ATCK01), a technician will have the ability to access the UPC to configure and diagnose equipment at the unit or from any room sensor. The technician will have full access to equipment status, parameter values, temperature, and humidity sensing as well as access to alarm history. The Equipment Touch App is easy to use and provides important insight into the system so it can operate as efficiently as possible.

The Aurora Advanced VS Control System cont.

Status LED (LED1, Red)		LED Flash Code *	Lockout	Reset/Remove	Fault Condition Summary	ABC Green Status LED	ABC Red Fault LED	AID Tool Display and History	IntelliZone2 and Thermostat Display
ABC & AXB Basic Faults	Normal - No Faults	Off	-	-	-	-	-	-	-
	Fault-High Pressure	1	No	Auto	Tstat input error. Autoreset upon condition removal.	Normal	Code 1		
	Fault-Low Pressure	2	Yes	Hard or Soft	HP switch has tripped (>600 psi)	Lockout	Code 2	Lockout - E2 High Press	Lockout - E2 High Press
	Fault-Freeze Detection FP2	3	Yes	Hard or Soft	Low Pressure Switch has tripped (<40 psi for 30 continuous sec.)	Lockout	Code 3	Lockout - E3 Low Press	Lockout - E3 Low Press
	Fault-Freeze Detection FP1	4	Yes	Hard or Soft	Freeze protection sensor has tripped (<15 or 30 degF for 30 continuous sec.)	Lockout	Code 4	Lockout - E4 Freeze Detection FP2	Lockout - E4 Freeze Detection FP2
	Fault-Condensate Overflow	5	Yes	Hard or Soft	Freeze protection sensor has tripped (<15 or 30 degF for 30 continuous sec.)	Lockout	Code 5	Lockout - E5 Freeze Detection FP1	Lockout - E5 Freeze Detection FP1
	Fault-Over/Under Voltage	7	Yes	Hard or Soft	Condensate switch has shown continuity for 30 continuous sec.	Lockout	Code 7	Lockout - E7 Condensate	Lockout - E7 Condensate
	Fault-FPI	8	No	Auto	Instantaneous Voltage is out of range. **Controls shut down until resolved.	Lockout	Code 8	Lockout - E8 Over/Under voltage	Lockout - E8 Over/Under voltage
	Non-CritCAXBsnsErr	11	Yes	Hard or Soft	FPI Sensor Error	Lockout	Code 11	Lockout - E11 FPI/FP2 Sensor Error	Lockout - E11 FPI/FP2 Sensor Error
	CritCAXBsnsErr	13	No	Auto	Any Other Sensor Error	Normal	Code 13	Alert - E13 Non-Critical AXB Sensor Error	Alert - E13 Non-Critical AXB Sensor Error
Miscellaneous	Alarm-HotWtr	14	Yes	Hard or Soft	Sensor Err for EEV or HW	Lockout	Code 14	Lockout - E14 Critical AXB Sensor Error	Lockout - E14 Critical AXB Sensor Error
	Fault-VarSpdPump	15	No	Auto	HW over limit or logic lockout. HW pump deactivated.	Normal	Code 15	Alert - E15 Hot Water Temp Limit	No Display
	Non-CritComErr	16	No	Auto	Alert is read from PWM feedback.	Normal	Code 16	Alert - E16 Var Spd Pump Err	Alert - E16 Var Spd Pump Err
	Fault-CritComErr	18	No	Auto	Any non-critical com error	Normal	Code 18	Alert - E18 Non-Critical Communication Error	Alert - E18 Non-Critical Communication Error
	Alarm - Low Loop Pressure	19	No	Auto	Any critical com error. Auto reset upon condition removal	Normal	Code 19	Alert - E19 Critical Communication Error	Alert - E19 Critical Communication Error
	Alarm - Home Automation 1	21	No	Auto	Loop pressure is below 3 psi for more than 3 minutes	Normal	Code 21	Alert - E21 Selected choice	Alert - E23 Selected choice
	Alarm - Home Automation 2	23	No	Auto	Closed contact input is present on Dig 2 input - Text is configurable	Normal	Code 23	Alert - E23 Selected choice	Alert - E24 Selected choice
	Derate-DriveTemp	24	No	Auto	Closed contact input is present on Dig 3 input - Text is configurable	Normal	Code 24	Alert - E24 Selected Choice	Alert - E24 Selected Choice
	Derate-HiDisTemp	41	No	Auto	Drive Temp has reached critical High Temp (>239 F/115 C)	Derated	Code 41	Warning! Derated - E41 DriveTemp	Warning! Derated - E41 DriveTemp
	Derate-LoSuctPres	42	No	Auto	Discharge temperature has reached critical high temp (> 280 F/138 C)	Derated	Code 42	Warning! Derated - E42 HiDisTemp	Warning! Derated - E42 HiDisTemp
Danfoss VS Drive	Derate-LoConPres	43	No	Auto	Suction Pressure is critically low (< 28 psig)	Derated	Code 43	Warning! Derated - E43 LoSuctPres	Warning! Derated - E43 LoSuctPres
	Derate-HiConPres	44	No	Auto	Condensing pressure is critically low (< 119 psig)	Derated	Code 44	Warning! Derated - E44 LoConPress	Warning! Derated - E44 LoConPress
	Derate-OutPwrLmt	45	No	Auto	Condensing pressure is critically high (> 654 psig)	Derated	Code 45	Warning! Derated - E45 HiConPress	Warning! Derated - E45 HiConPress
	SafeMd-EEV/VndCom	46	No	Auto	Supply Voltage is <208V or Max Pwr is reached due to high pressure	Derated	Code 46	Warning! Derated - E46 OutPwrLmt	Warning! Derated - E46 OutPwrLmt
	SafeMd-EEV/OutCom	47	No	Auto	Com with EEV is interrupted EEV has gone independent mode	SafeMode	Code 47	Warning! SafeMode - E47 EEV/VndCom	Warning! SafeMode - E47 EEV/VndCom
	SafeMd-AmbTempSnr	48	No	Auto	Com with EEV is interrupted EEV has gone independent mode	SafeMode	Code 48	Warning! SafeMode - E48 EEV/OutCom	Warning! SafeMode - E48 EEV/OutCom
	Fault-DistTempSnr	49	No	Auto	Ambient Temperature (Tamb) is <76 or > 212 F and out of range or invalid	SafeMode	Code 49	Warning! SafeMode - E49	Warning! SafeMode - E49
	Fault-ConPrsSnr	51	Yes	Hard or Soft	Discharge Sensor (Sd) is > 280 F or invalid (-76 to 392 F)	Lockout	Code 51	Lockout! - E51 DisTempSnr	Lockout! - E51 DisTempSnr
	Fault-LowSupVolt	52	Yes	Hard or Soft	Suction Pressure (PO) is invalid (0 to 232 psi)	Lockout	Code 52	Lockout! - E52 SuctPrsSnr	Lockout! - E52 SuctPrsSnr
	Fault-OutEnvelop	53	10x then Yes	Hard or Soft	Low condensing pressure (PD) is invalid (0 to 870 psi) Retry 10x.	Norm then Lockout	Code 53	Lockout! - E53 ConPrsSnr	Lockout! - E53 ConPrsSnr
Ind/Pkg Danfoss EEV2	Fault-OverCurrnt	54	Yes	Hard or Soft	Supply Voltage is <180 V (180V to reset) or powered off/on too quickly (<30 sec.).	Lockout	Code 54	Lockout! - E54 LowSupVolt	Lockout! - E54 LowSupVolt
	Fault-Over/UnderVolt	55	Yes	Hard or Soft	Comp Operating out of envelope (PO) more than 90 sec. Retry 10x.	Norm then Lockout	Code 55	Lockout! - E55 OutEnvelop	No Display
	Fault-HiDrivTemp	56	Yes	Hard or Soft	Over current tripped by phase loss, earth fault, short circuit, low water flow, low air flow, or major drive fault.	Lockout	Code 56	Lockout! - E56 OverCurrnt	Lockout! - E56 OverCurrnt
	Fault-DrivntErr MOC/AOC	57	Yes	Hard or Soft	DC Link Voltage to compressor is >450vdc or at minimum voltage (<165vdc).	Lockout	Code 57	Lockout! - E57 Over/Under Volt	Lockout! - E57 Over/Under Volt
	Fault-LossOfCharge	58	Yes	Hard or Soft	Drive Temp has reached critical High Temp >239 F	Lockout	Code 58	Lockout! - E58 HiDrivTemp	Lockout! - E58 HiDrivTemp
	SafeMd-SucTempSnr	59	Yes	Hard or Soft	The MOC has encountered an internal fault or an internal error. Probably fatal.	Lockout	Code 59	Lockout! - E59 DrvntErr	Lockout! - E59 DrvntErr
	SafeMd-LATSnsor	61	Yes	Hard or Soft	More than one SafeMode condition is present requiring lockout.	Lockout	Code 61	Lockout! - E61 MultiSafeMd	Lockout! - E61 MultiSafeMd
	SafeMd-MaxOpPres	71	Yes	Hard or Soft	High superheat and high EEV opening % for a long time will trigger a loss of charge fault	Lockout	Code 71	Lockout! - E71 LossCharge	Lockout! - E71 LossCharge
		72	No	Auto	Suction Temperature Sensor is invalid (-76 to 392 F)	SafeMode	Code 72	Warning! SafeMode - E72 SuctTempSnr	Warning! SafeMode - E72 SuctTempSnr
		73	No	Auto	Leaving Air Temperature Sensor is invalid (-76 to 392 F)	Normal	Code 73	Alert - E73 LAT Sensor	No Display
	74	No	Auto	Suction pressure has exceeded that maximum operating level for 90 sec.	SafeMode	Code 74	Warning! SafeMode - E74 MaxOpPres	Warning! SafeMode - E74 MaxOpPres	

NOTES: *All codes >11 use long flash for tens digit and short flash for the ones digit. 20, 30, 40, 50 etc. are skipped!
Alert! is a noncritical sensor or function that has failed. Normal operation of the heat pump is maintained but service is desired at some point.

The Aurora Advanced VS Control System cont.

ABC Control Board Layout

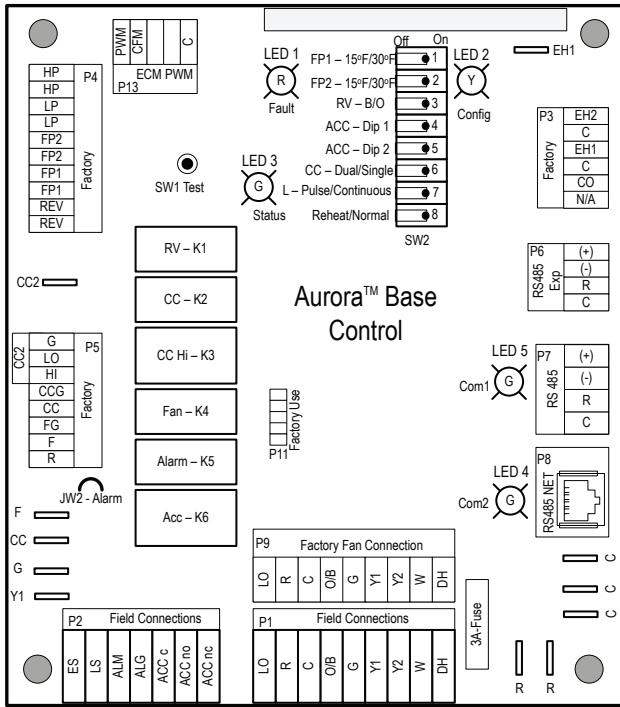

AXB Control Board Layout

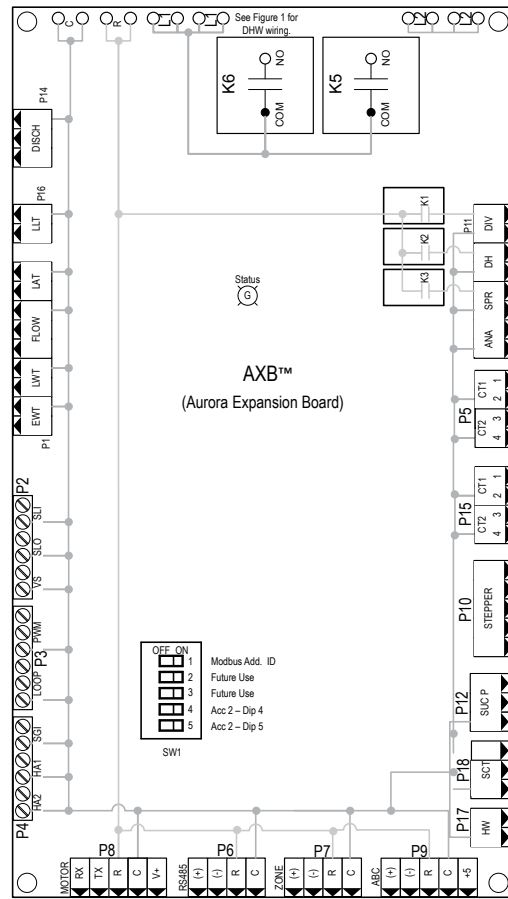

EEV Board Layout

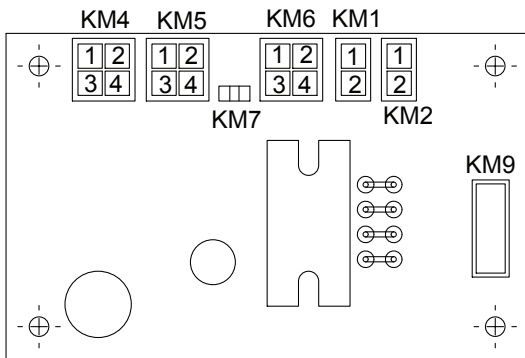

Variable Speed Drive

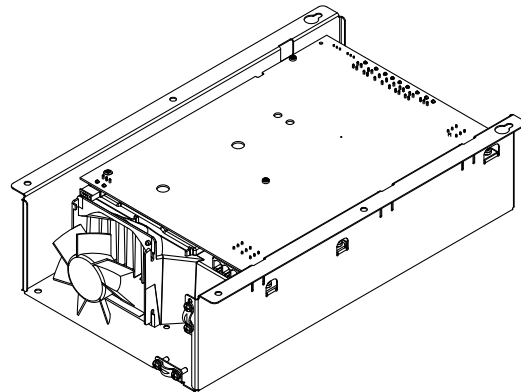

Operation Logic

Heating Mode

When the variable speed controls determine that heating is needed in the space the blower will be turned on, the compressor will be ramped to speed 6 and the loop pump will be started. The compressor will continue to run at speed 6 for 60 seconds for oil circulation. During the 60 second oil circulation the controls will calculate what speed the compressor will need to operate at to maintain the set point in the space. If the compressor is operating at speed 12 and the unit is unable to maintain set point the controls will stage on the electric heat. Electric heat will not operate unless the compressor is already running at speed 12. Every 30 minutes if the compressor has been operating lower than speed 6, the controls will increase the compressor to speed 6 for one minute for oil circulation.

Cooling Mode

When the variable speed controls determine that cooling is needed in the space the blower will be turned on, the reversing valve will be enabled, the compressor will be ramped to speed 6, and the loop pump will be started. The compressor will continue to run at speed 6 for 60 seconds for oil circulation. During the 60 second oil circulation the controls will calculate what speed the compressor will need to operate at to maintain the set point in the space. The compressor will be limited to a maximum of speed 9 for cooling. If additional capacity is needed SuperBoost mode can be enabled from the thermostat allowing the compressor to run at speeds higher than 9 for a period of 24 hours. Every 30 minutes if the compressor has been operating lower than speed 6, the controls will increase the compressor to speed 6 for one minute for oil circulation.

ECM Blower Motor

The variable speed controls will vary the ECM blower output to maintain optimum air flow at each of the 12 compressor speeds. If dehumidification mode is selected during the cooling operation the airflow will be varied to allow for maximum moisture removal.

Variable Speed Loop Pump

The variable speed controls will operate the variable speed loop pump similar to the way the ECM blower motor operates. The speed of the pump will be increased as the compressor speed is increased to maintain adequate water flow.

Safe Mode

The system has encountered an unsafe operating condition that prevents automatic speed control, e.g. lost a sensor signal. To avoid damage to the system, the drive is running the compressor at a fixed speed of 2400 rpm awaiting the problem to be solved and eventually returning to normal operation. If the problem cannot be solved the drive stops and issues an alarm. (See fault/alarm table.)

Derating

The VS compressor utilizes 'envelope control' to maintain performance within operational limits and improve reliability. To accomplish this, pressure sensors for discharge and suction pressure as well as hot gas temperature sensing are used to monitor the conditions in which the compressor operates. The envelope does vary based upon operating speed (rpm). When operating out of these limits the control will attempt to improve the situation by moderating the compressor speed for a larger envelope. When this occurs it can be observed on the Aurora control as an 'E' code. The control will automatically try to resolve the situation. If the situation progresses, a fault and lockout will be generated by the control.

Wiring Schematics

Aurora Variable Speed

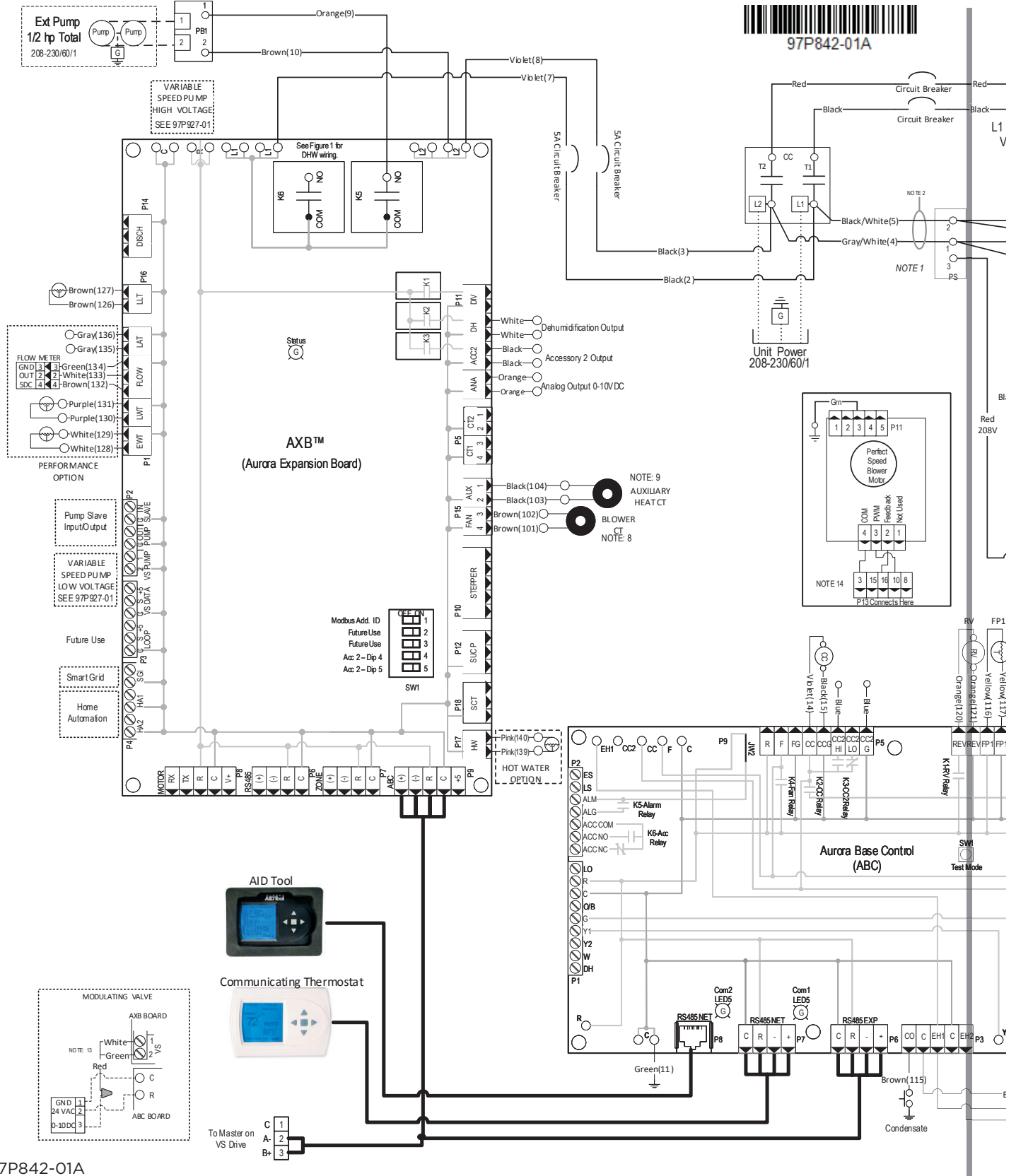

97P842-01A

Wiring Schematics cont.

Aurora Variable Speed cont.

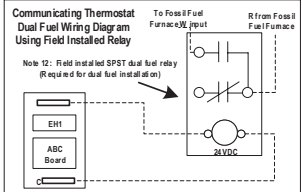
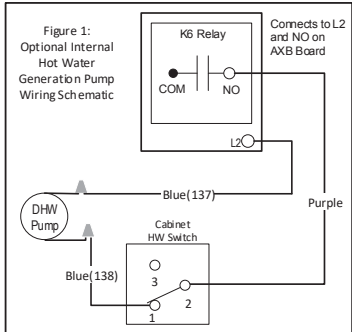
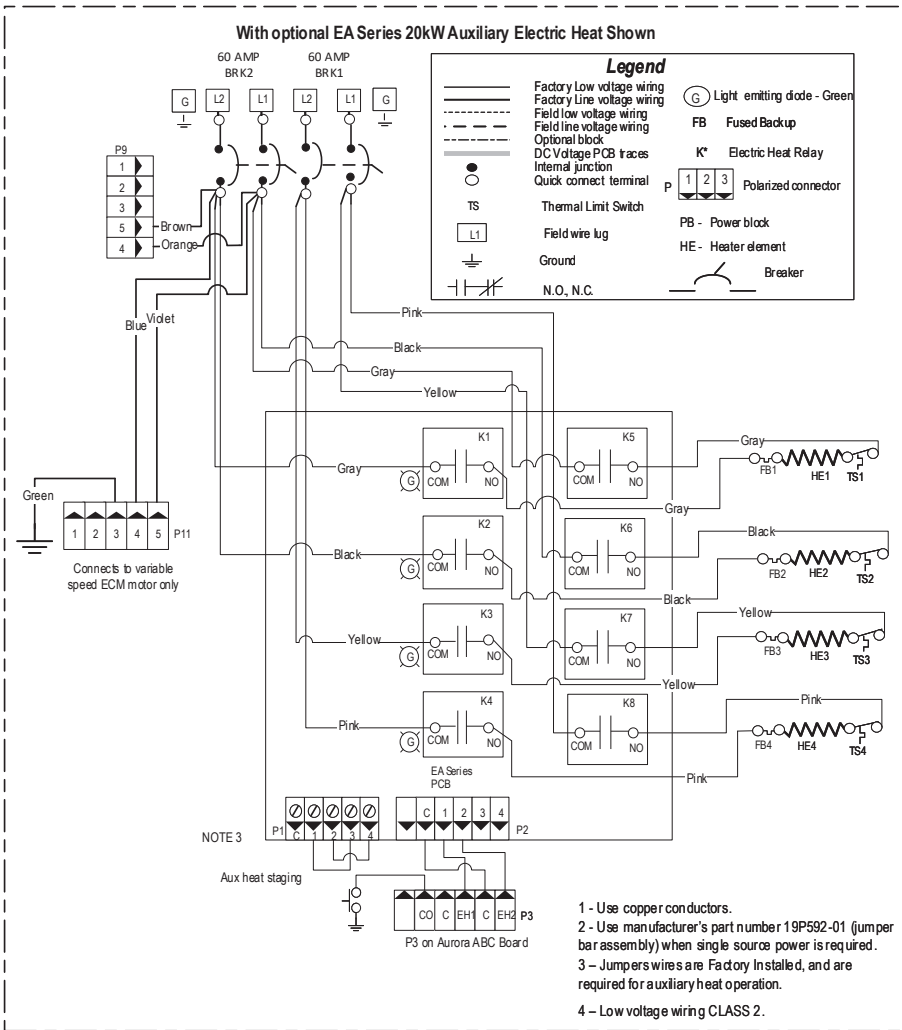
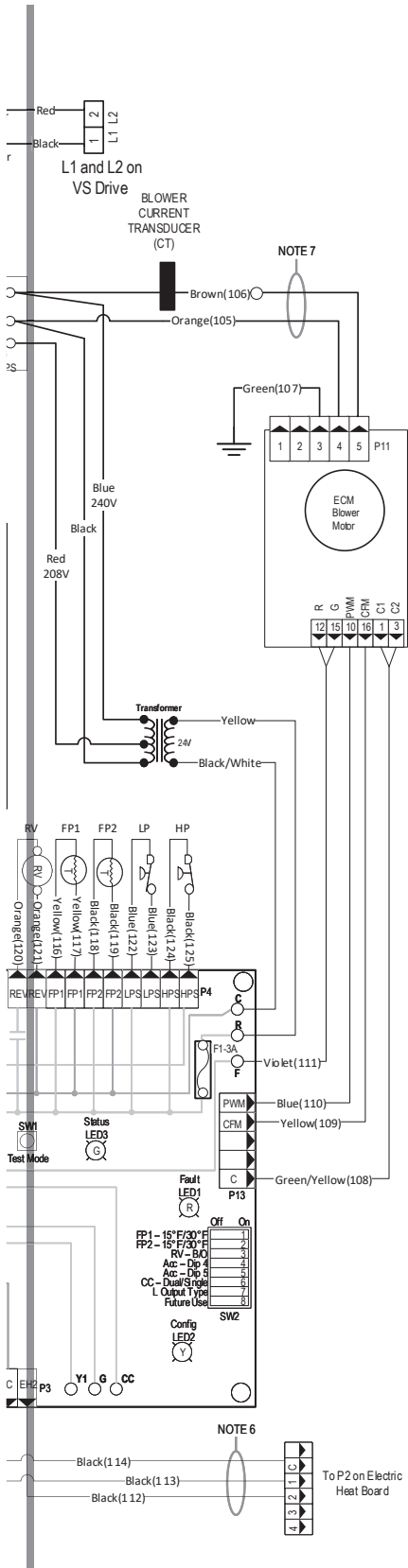

- ### Notes
- 1 - Switch blue and red wires for 208V operation.
 - 2 - The blk/wh and gray/wh wires are removed when Aux Heat is installed
 - 3 - Use manufacturer's part number 19P592-01 (jumper bar assembly) when single source power is required.
 - 4 - Variable speed pump low voltage harness provided with Variable Speed Flow Center.
 - 5 - Low voltage wiring CLASS 2.
 - 6 - Wires provided for Auxiliary Heat low voltage control. Wires are secured at blower.
 - 7 - When Auxiliary Heat is field installed the harness will then be connected to the auxiliary heat unit. The auxiliary heat unit will then power the blower. Refer to EAS/EAMEAL Auxiliary Heat kit installation instructions.
 - 8 - Brown blower power wire routed through Current Transducer two times.
 - 9 - Field Connected: Refer to Installation Manual and Auxiliary Heat Instructions for Current Transducer installation.
 - 10 - Communication cable routed through Ferrite Toroid four times.
 - 11 - Compressor power cable routed through Ferrite Toroid three times.
 - 12 - Field installed SPST relay required for dual fuel installation.
 - 13 - Wiring harness supplied with valve.
 - 14 - On units with the NIDEC ECM motor the P13 harness connects to the jumper harness on the motor.

Wiring Schematics cont.

Aurora Variable Speed Drive/EEV Wiring

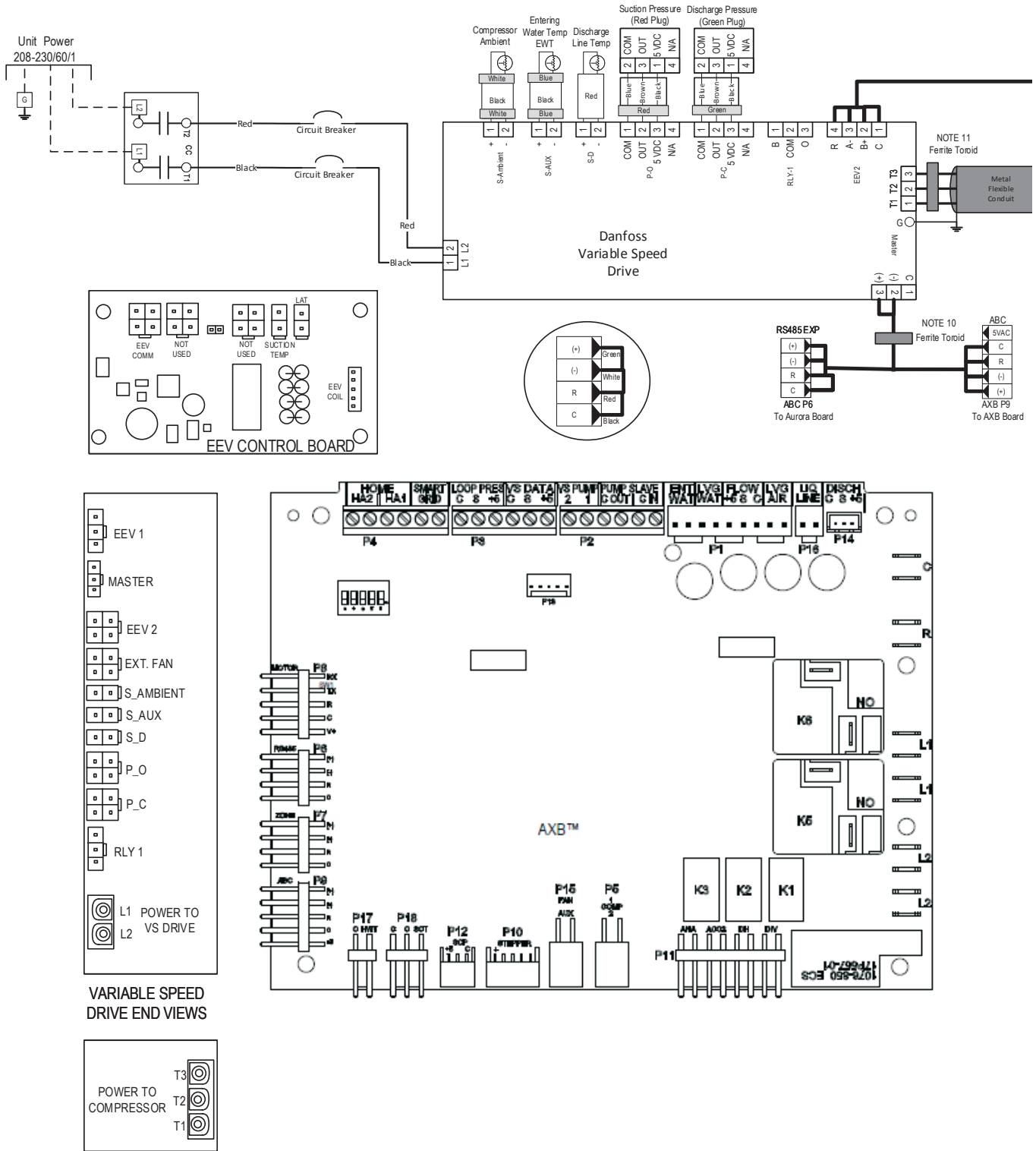

Wiring Schematics cont.

Aurora Variable Speed Drive/EEV Wiring cont.

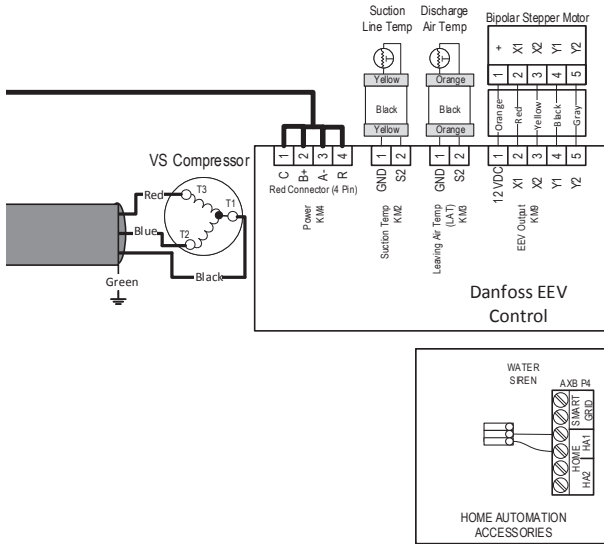

Legend

- Factory Low voltage wiring
- Factory Line voltage wiring
- Field low voltage wiring
- Field line voltage wiring
- Optional block
- DC Voltage PCB traces
- Junction
- Quick connect terminal
- Wire nut
- Field wire lug
- Ground
- Relay Contacts- N.O., N.C.
- Fuse
- Color identification tape on wire.
- Thermistor
- Light emitting diode - Green
- Relay coil
- Capacitor w/ bleed resistor
- Switch - Condensate overflow
- Switch - High pressure
- Switch - Low pressure
- Polarized connector
- Current Transducer (CT)

CC - Compressor Contactor
CO - Condensate overflow sensor
KB - DHW pump relay
KS - Loop pump relay
CR3 - PSC Fan Speed Relay
CR4 - PSC Fan Power Relay
CS - Compressor Solenoid
F1 and F2 - Fuses
HE - Heater element
HP - High pressure switch
ER1 to ER4 - Aux heat stage relays
LP - Low pressure switch
PB1, PB2 - Power blocks
PS - Power strip
RV - Reversing Valve coil
SW1 - DIP package 5 position AXB TEST MODE ABC Board
SW2 - DIP package 8 position ABC Board
TS - Thermal limit switch
HWL - Hot water limit sensor
SC - Start Contactor
SR - Start Relay
WCL - Water Coil Limit Sensor

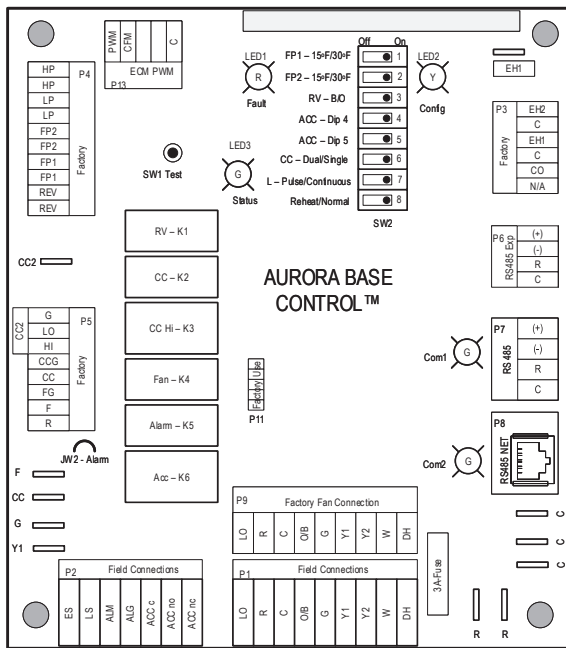

ABC SW2 Accessory Relay		
DESCRIPTION	SW2-4	SW2-5
Cycle with Blower	ON	ON
Cycle with Compressor	OFF	OFF
Water Valve Slow Opening	ON	OFF
Cycle with Comm. T-stat Hum Cmd	OFF	ON

AXB Accessory 2 DIP Settings		
SW1-4	SW1-5	DESCRIPTION
ON	ON	Cycles with Blower
OFF	ON	Cycles with CC first stage compressor or compressor spd 1-12
ON	OFF	Cycles with CC2 second stage of compressor or comp spd 7-12
OFF	OFF	Cycles with DH from ABC board

Aurora LED Flash Codes			
Slow Flash	1 second on and 1 second off		
Fast Flash	100 milliseconds on and 100 milliseconds off		
Flash Code	100 milliseconds on and 400 milliseconds off with a 2 second pause before repeating		
	Fault LED (LED 1, Red)	Random Start Delay (Alternating Colors)	
Normal Mode	OFF	Status LED (LED1, Green)	Fast Flash
Input Fault Lockout	Flash Code 1	Configuration LED (LED 2, Yellow)	Fast Flash
High Pressure Lockout	Flash Code 2	Fault LED (LED 3, Red)	Fast Flash
Low Pressure Lockout	Flash Code 3	Configuration LED (LED 2, Yellow)	
Freeze Detection- FP2	Flash Code 4	No Software Override	OFF
Freeze Detection - FP1	Flash Code 5	DIP Switch Override	Slow Flash
Reserved	Flash Code 6	Status LED (LED 3, Green)	
Condensate Overflow Lockout	Flash Code 7	Normal Mode	ON
Over/Under Voltage Shutdown	Flash Code 8	Control is Non - Functional	OFF
Future Use	Flash Code 9	Test Mode	Slow Flash
Fault- FP1 and FP2 Sensor Error	Flash Code 11	Dehumidification Mode	Flash Code 2
Future Use	Flash Code 12	Future Use	Flash Code 3
Non-Critical AXB Sensor Error	Flash Code 13	Future Use	Flash Code 4
Critical AXB Sensor Error	Flash Code 14	Load Shed	Flash Code 5
Alarm - Hot Water	Flash Code 15	ESD	Flash Code 6
Fault Variable Speed Pump	Flash Code 16	Future Use	Flash Code 7
Future Use	Flash Code 17	Fault LED (LED 1, Red) Cont.	
Non-Critical Communication Error	Flash Code 18	Safe Mode - Ambient Temperature Sensor	Flash Code 49
Fault - Critical Communication Error	Flash Code 19	Fault - Discharge Temperature Sensor	Flash Code 51
Alarm - Low Loop Pressure	Flash Code 21	Fault - Suction Pressure Sensor	Flash Code 52
Fault - Communication ECM Fan Motor Error	Flash Code 22	Fault - Condensing Pressure Sensor	Flash Code 53
Alarm - Home Automation 1	Flash Code 23	Fault - Low Supply Voltage	Flash Code 54
Alarm - Home Automation 2	Flash Code 24	Fault - Compressor Out of Envelope	Flash Code 55
Fault - EEV Error	Flash Code 25	Fault - Over Current	Flash Code 56
Derate - Drive Temperature	Flash Code 41	Fault - Over/Under Voltage	Flash Code 57
Derate - High Discharge Temperature	Flash Code 42	Fault - High Drive Temperature	Flash Code 58
Derate - Low Suction Temperature	Flash Code 43	Fault - Drive Internal Error MOC/AOC	Flash Code 59
Derate - Low Condensing Pressure	Flash Code 44	Fault - Multiple Safe Modes	Flash Code 61
Derate - High Condensing Pressure	Flash Code 45	Fault - Loss of Charge	Flash Code 71
Derate - Outer Power Limit	Flash Code 46	Safe Mode - Suction Temperature Sensor	Flash Code 72

Wiring Schematics cont.

Aurora Variable Speed with UPC

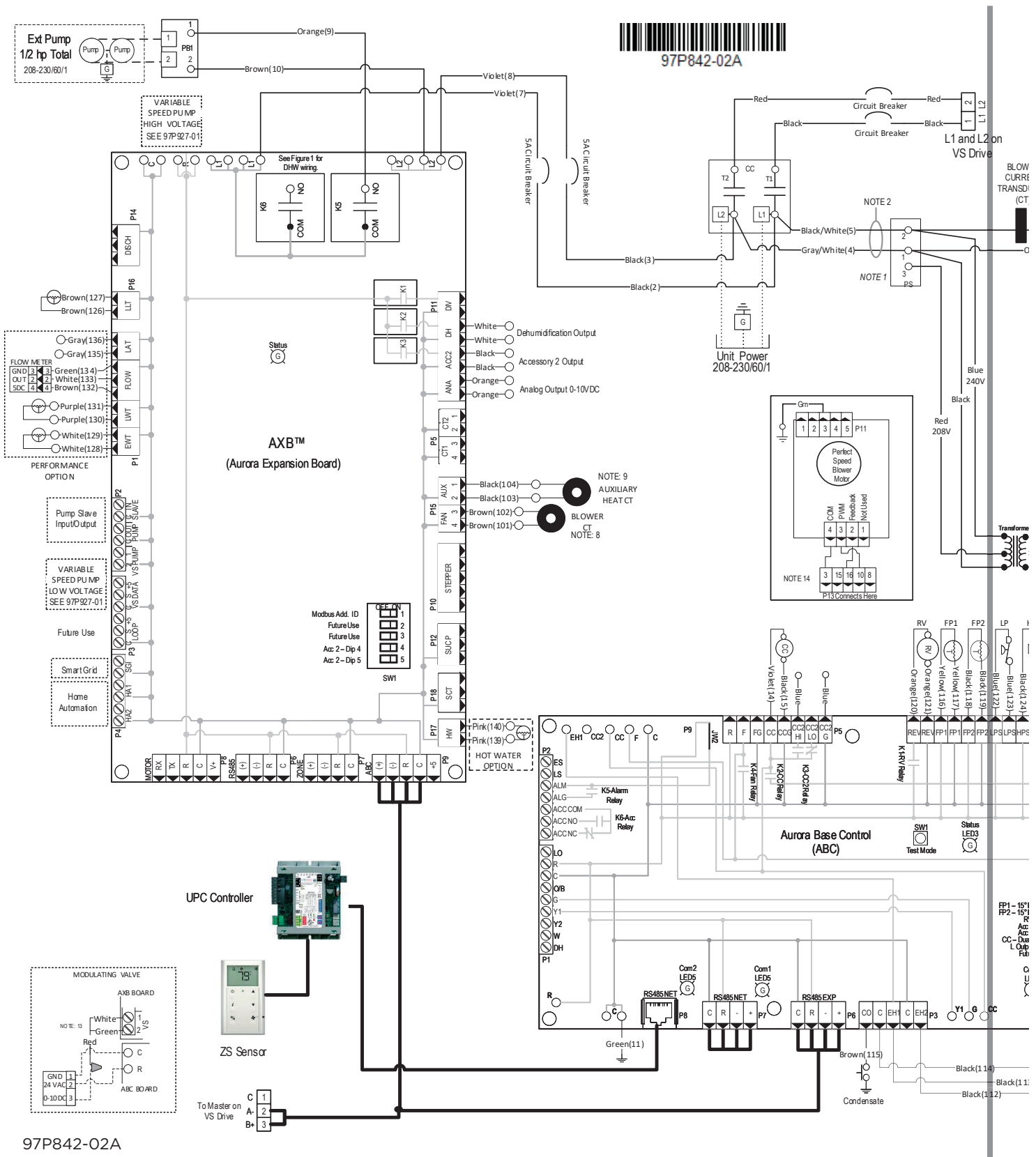

Wiring Schematics cont.

Aurora Variable Speed with UPC cont.

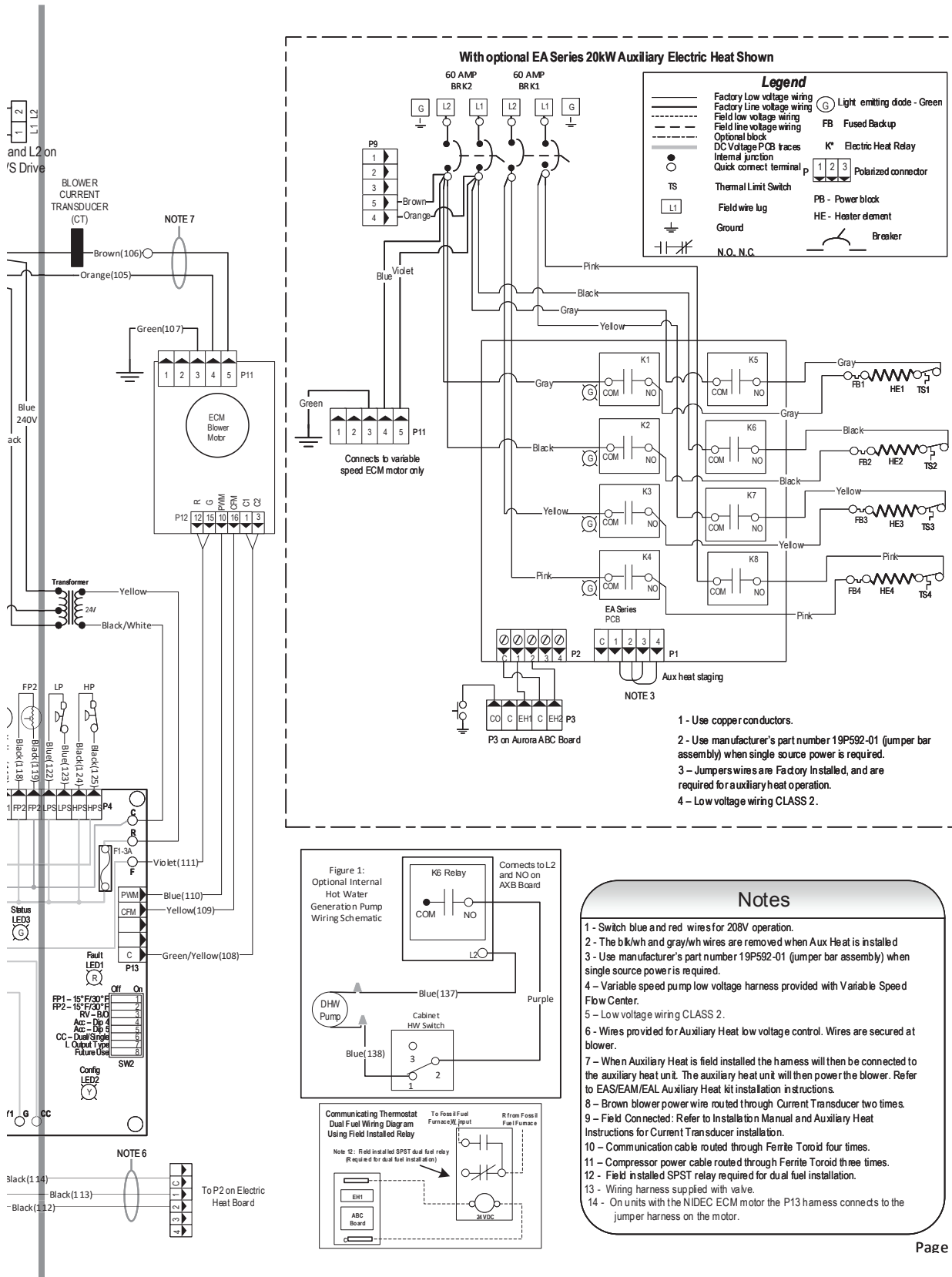

Wiring Schematics cont.

Aurora UPC

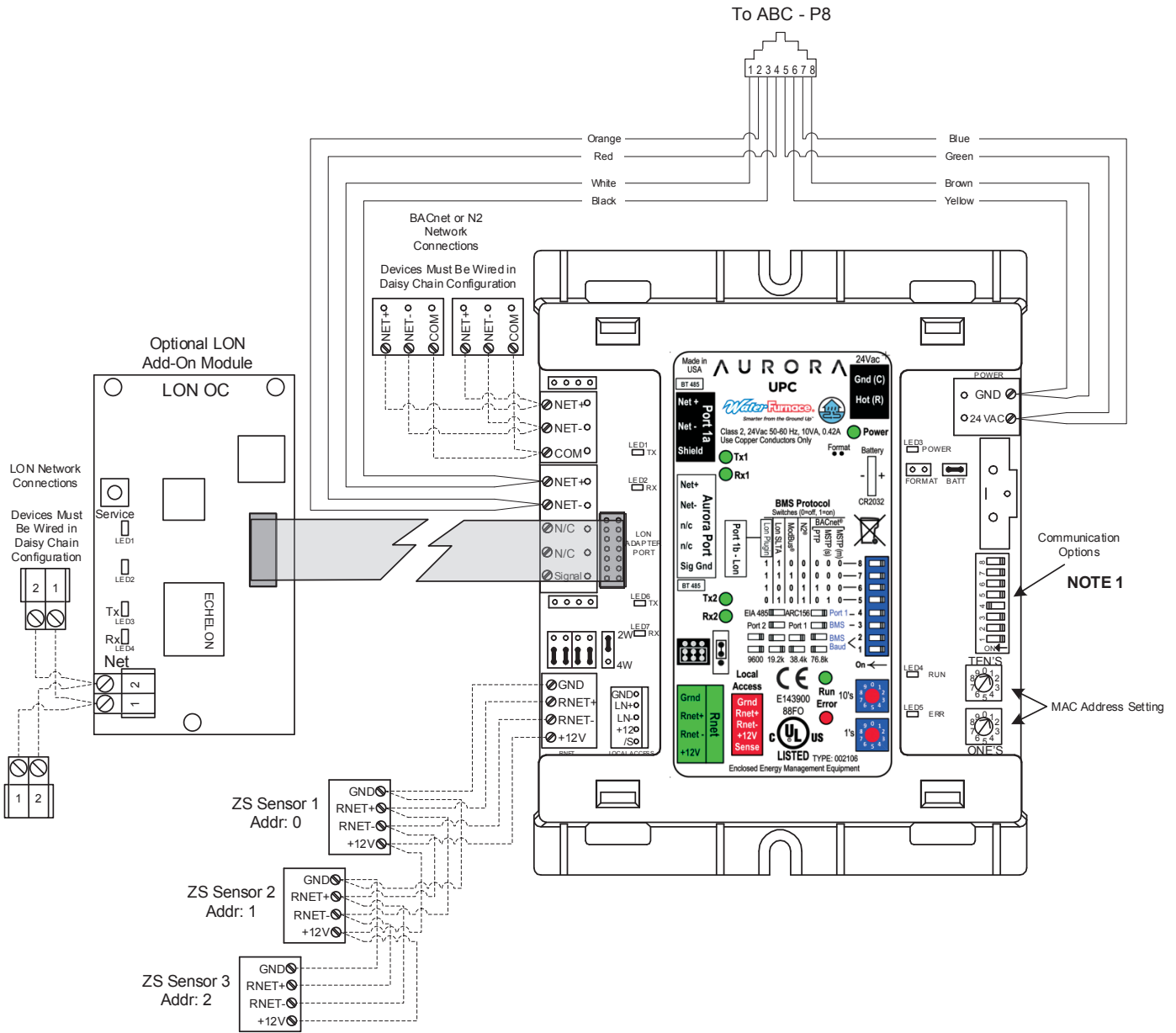

ZS Sensor Information

Zone Sensors can be wired in daisy chain as show or in a star or hybrid configuration. Maximum of 5 sensors per UPC. Maximum allowable load 210mA. See the UPC install manual for possible sensor combinations.

DIP Switch Value
1
2
4
8

Each ZS sensor must have a unique address, but the addresses do not need to be sequential. Use the DIP switches on the back of the ZS sensor to set an address from 0 to 4. (0 is the factory default.) Each DIP switch has the value shown in the figure to the left. Turn on as many DIP switches as you need so that their total value equals the address.

Notes

1. Use DIP Switches 5 – 8 to change communication protocol and DIP switches 1 – 2 to change BACnet baud rate

Legend

- Factory Low Voltage Wiring
- - - Field Low Voltage Wiring
- RJ45 Connector

Unit Startup

Before Powering Unit, Check the Following:

NOTE: Remove and discard the compressor hold down shipping bolt located at the front of the compressor mounting bracket.

- **Black/white and gray/white wires in unit control box have been removed if auxiliary heat has been installed.**
- **Dip switches are set correctly.**
- **Transformer switched to 208V if applicable.**
- **High voltage is correct and matches nameplate.**
- Fuses, breakers and wire size correct.
- Low voltage wiring complete.
- Piping completed and water system cleaned and flushed.
- Air is purged from closed loop system.
- Isolation valves are open, water control valves or loop pumps wired.
- Condensate line open and correctly pitched.
-
- Hot water generator pump switch is “OFF” unless piping is completed and air has been purged.
- Blower rotates freely.
- Blower speed is correct.
- Air filter/cleaner is clean and in position.
- Variable speed drive filter is clean and in place.
- Service/access panels are in place.
- Return air temperature is between 50-80°F heating and 60-95°F cooling.
- Check air coil cleanliness to ensure optimum performance. Clean as needed according to maintenance guidelines. To obtain maximum performance the air coil should be cleaned before startup. A 10-percent solution of dishwasher detergent and water is recommended for both sides of coil, a thorough water rinse should follow.

Powering The Controls

Initial Configuration of the Unit

Before operating the unit, apply power and complete the following Aurora Startup procedure for the controls configuration. An AID Tool is required for setup, configuration, and troubleshooting on the 7 Series Variable Speed system. AID Tool version 2.04 or greater is preferred.

1. Configure Aurora Screen

- a. Confirm AXB is added and communicating.
- b. Confirm AOC is added and communicating.
- c. Confirm MOC is added and communicating.
- d. Confirm EEV2 is added and communicating.
- e. Confirm IntelliZone2 is added and communicating if installed. Set zoning system to OFF.
- f. Confirm communicating thermostat is added and communicating if IntelliZone2 is not installed. Set thermostat mode to OFF.

NOTE: The AOC and MOC are the two boards that comprise the VS drive.

2. Aurora Setup Screen

- a. ECM Setup for Heating Airflow – select G, low, high and aux blower speeds as appropriate for the unit and electric heat.
- b. Cooling Airflow % – sets the cooling airflow % from heating airflow. Factory setting is -15%
- c. AXB Setup
 - i. DHW Enable – Ensure air is purged from HW system before enabling (remember the HW switch on the front cabinet)
 - ii. DHW Setpoint – 130 °F is the default but can be changed from 100 to 140 °F
 - iii. 7 Series Variable Speed Pump Setup and Modulating Water Valve Setup – Can be setup to a range between 5% and 100%. Defaults are 50% and 100%.
 - From the Main Menu of the AID Tool go to AXB Setup and select “Yes” at the bottom of the screen to Make Changes
 - Set VS Pump Control to MIN
 - The pump(s) or water valve should begin to operate and flow rate is visible on this screen, it may take several seconds for flow to stabilize. Adjust the minimum % until the minimum flow rate is achieved.
 - Go back to Set VS Pump Control and select MAX.
 - The pump(s) or water valve should begin to operate and flow rate is visible on this screen, it may take several seconds for flow to stabilize. Adjust the maximum % until the maximum flow rate is achieved.
 - Press Enter.
- d. Sensor Kit Setup
 - i. Brine Selection – for HE/HR capacity calculation
 - ii. Flow Meter – activates the flow meter
 - iii. Pump - Select the correct flow center option using the table below. If using an open system select “Open Loop.” This selection is used to calculate the system pumping watts.

Sensor Kit Setup Screen in AID TOOL			
FC1	FC2	VS Pump	VS X2 Pump
FC1-GL	FC2-GL	FCV1B-GL	FCV2B-GL
FC1-FPT	FC2-FPT		
FC1-GLNP	FC2-GLNP	FCV1B-GLNPP	FCV2B-GLNPP
FC2-GLNPD	FC4-GLNPD		
FC3-GLNPD (right side)	FC3-GLNPD (left side)		
FCV2AB-GLNPD (right side)		FCV2AB-GLNPD (left side)	
		FCV2BB-GLNPD (right & left side)	
		FCV3CB-GLNPD (right side)	FCV3CB-GLNPD (left side)
			FCV4AB-GLNPD (right & left side)

Unit Startup cont.

- iii. Activate energy option
- iv. Select blower energy – PSC or ECM/5-Speed ECM
- v. Line Voltage calibration – Voltmeter required to calibrate line voltage during heating or cooling. Refer to Line Voltage Calibration in this manual for more details.
- e. Smart Grid Setup – Select action option for utility received On Peak signal
- f. Home Automation 1 and 2 Setup – Select type of sensor for two home automation inputs.
- e. Energy monitoring can be read on any of the following components:
 - i. AID Tool – instantaneous information only
 - ii. TPCM32U04A Communicating Thermostat (B/W) - instantaneous information only
 - iii. TPCC32U01 Color Touchscreen Thermostat – Both Instantaneously and historical (13 months)
 - iv. WaterFurnace Web Portal via AWL device connected to Aurora

Configuring the Sensor Kits

Configuring the Sensor kits

The Aurora Advanced Control allows Refrigeration, Energy, and Performance Monitoring sensor kits. These kits can be factory or field installed. The following description is for field activation of a factory installation of the sensor kits.

Energy Monitoring

(Standard Sensor Kit Variable Speed Models)

The Energy Monitoring Kit includes two current transducers (fan and electric heat) added to the existing compressor drive sensor so that the complete power usage of the heat pump can be measured. The AID Tool provides configuration detail for the type of blower motor and a line voltage calibration procedure to improve the accuracy. This information can be displayed on the AID Tool or selected communicating thermostats. The TPCM32U04A will display instantaneous energy use while the color touchscreen TPCC32U01 will in addition display a 13 month history in graph form. Ensure the Energy Kit has been enabled by accessing the 'Sensor Kit Setup' in the AID Tool and complete the following:

- a. Select 'Blower Energy' – PSC or ECM/5-Speed ECM
- b. Activate 'Energy Option' to activate the sensors on for compressor (2), blower and aux heat current sensor.
- c. Select 'Pump' option of FC1, FC2, VS Pump, VS X2 Pump, VS + 26-99, or open loop. This selects the pump watts used in the calculation. Pump watts are measured on VS pumps and estimated on fixed speed pumps.
- d. Line Voltage Calibration – Voltmeter required to calibrate line voltage during heating or cooling.
 - i. Turn on Unit in Heating or Cooling .
 - ii. Use multimeter at L1 and L2 to measure line voltage
 - iii. In the Sensor Kit Setup screen adjust the 'Base Voltage' to the nearest value to that is measured
 - iv. Then use the 'Fine Adjust' to select the exact voltage being measured at L1 and L2.
 - v. Exit 'Sensor Setup' Screen

Refrigerant Monitoring

(Standard on Variable Speed Models)

The Refrigerant Monitoring Kit includes two pressure transducers, and three temperature sensors, heating liquid line, suction temperature, and existing cooling liquid line (FP1). These sensors allow the measurement of discharge and suction pressures, suction and liquid line temperatures as well as superheat and subcooling. This information will only be displayed on the AID Tool. Ensure the Refrigerant Monitoring has been setup by accessing the 'Sensor Kit Setup' in the AID Tool and complete the following:

Once sensors are installed for discharge pressure, suction pressure, suction, liquid line cooling, liquid line heating, and leaving air temperature no further setup is required.

- a. Turn on unit in Heating or Cooling.
- b. Use the AID Tool to view the refrigerant performance in the 'Refrigerant Monitor' screen.
- c. Refrigerant monitoring can be read on any of the following components:
 - i. AID Tool – instantaneous information only
 - ii. WF Web Portal via AWL device connected to Aurora

Performance Monitoring

(Optional Sensor Kit)

The optional Performance Monitoring Kit includes three temperature sensors, entering and leaving water, leaving air temperature and a water flow rate sensor. With this kit heat of extraction and rejection will be calculated. This requires configuration using the AID Tool for selection of water or antifreeze. Ensure the Performance Kit has been enabled by accessing the 'Sensor Kit Setup' in the AID Tool and complete the following:

- a. Select 'Brine' – and then choose Water or Antifreeze for the proper factor
- b. Activate 'Flowmeter' to activate the flow sensor select the appropriate 3/4 in., 1 in., or none (1 in. is standard on variable speed units).
- c. Exit 'Sensor Kit Setup' screen.
 - i. Enter the AXB Setup Screen and turn the VS Pump Control ON
 - ii. Then set the VS Pump Min % to achieve at least 2.5 gpm per ton for part load operation.

Unit Startup cont.

- iii. Then set the VS Pump Max % to achieve at least 3.0 gpm per ton for full load operation.
- d. Turn on unit in Heating or Cooling.
- e. Use the AID Tool to view the performance in the 'Performance Monitor' screen.
- f. Performance monitoring can be read on any of the following components:
 - i. AID Tool - instantaneous information only
 - ii. WaterFurnace Web Portal via AWL device connected to Aurora
- 15. Adjust the heating setpoint below room temperature and verify that the compressor and water valve or loop pumps deactivate.
- 16. During all testing, check for excessive vibration, noise or water leaks. Correct or repair as required.
- 17. Set system to desired normal operating mode and set temperature to maintain desired comfort level.
- 18. Instruct the owner/operator in the proper operation of the thermostat and system maintenance.

NOTE: Be certain to fill out and forward all warranty registration papers.

Startup Steps

NOTE: Complete the Equipment Startup/Commissioning Check Sheet during this procedure. Refer to thermostat operating instructions and complete the startup procedure. Verify that the compressor shipping bolt has been removed.

1. Initiate a control signal to energize the blower motor. Check blower operation through the AID Tool.
2. Initiate a control signal to place the unit in the cooling mode. Cooling setpoint must be set below room temperature.
3. First stage cooling will energize after a time delay.
4. Be sure that the compressor and water control valve or loop pump(s) are activated.
5. Verify that the water flow rate is correct by measuring the pressure drop through the heat exchanger using the P/T plugs and comparing to unit performance data in catalog or view on the AID Tool if Performance Kit is installed.
6. Check the temperature of both the supply and discharge water (see the Unit Operating Parameters tables).
7. Check for an air temperature drop of 15°F to 25°F across the air coil (cooling compressor speed 9), depending on the blower speed and entering water temperature.
8. Decrease the cooling set point several degrees and verify high-speed blower operation.
9. Adjust the cooling setpoint above the room temperature and verify that the compressor and water valve or loop pumps deactivate.
10. Initiate a control signal to place the unit in the heating mode. Heating set point must be set above room temperature.
11. First stage heating will energize after a time delay.
12. Check the temperature of both the supply and discharge water (see the Unit Operating Parameters tables).
13. Check for an air temperature rise of 12°F to 35°F across the air coil (heating compressor speed 12), depending on the fan speed and entering water temperature.
14. If auxiliary electric heaters are installed, increase the heating setpoint until the electric heat banks are sequenced on (must get to compressor speed 12 before auxiliary heat enables). All stages of the auxiliary heater should be sequenced on when the thermostat is in the Emergency Heat mode. Check amperage of each element.

Pressure Drop

Model	GPM	Pressure Drop (psi)				
		30°F	50°F	70°F	90°F	110°F
36	11.5	3.60	3.30	3.10	2.90	2.70
	9.0	2.30	2.10	2.00	1.90	1.70
	7.0	1.50	1.40	1.30	1.20	1.10
	6.0	1.20	1.15	1.10	1.05	1.00
	4.5	0.70	0.66	0.64	0.60	0.55
48	13.5	4.60	4.40	4.10	3.80	3.50
	10.5	2.90	2.70	2.50	2.30	2.20
	7.5	1.70	1.60	1.50	1.40	1.30
	6.0	1.20	1.10	1.00	0.96	0.91
	4.0	0.62	0.61	0.60	0.58	0.56
60	17.0	6.40	6.00	5.60	5.20	4.80
	13.5	4.60	4.40	4.10	3.80	3.50
	9.5	2.20	2.10	2.00	1.80	1.70
	7.5	1.70	1.60	1.50	1.40	1.30
	5.0	0.68	0.62	0.58	0.55	0.53

12/02/20

Thermistor Resistance

Thermistor Resistance (10k Ohm) for FP1, FP2, HWL, LWT and LLT (EWT with Performance Option)		Thermistor Resistance (1k Ohm) for compressor discharge line, suction line, LAT, compressor ambient and EWT	
Thermistor Temperature (°F)	Thermistor Resistance (Ohms)	Thermistor Temperature (°F)	Thermistor Resistance (Ohms)
5	75757-70117	20	974.4-973.4
14	57392-53234	25	985.4-984.4
23	43865-40771	30	996.1-995.1
32	33809-31487	35	1007.0-1006.0
41	26269-24513	40	1017.8-1016.8
50	20570-19230	45	1028.6-1027.6
59	16226-15196	50	1039.5-1038.5
68	12889-12093	55	1050.2-1049.2
77	10310-9688	60	1061.2-1060.2
86	8300-7812	65	1072.9-1071.9
95	6723-6337	70	1082.7-1081.7
104	5480-5172	75	1093.4-1092.4
113	4490-4246	80	1103.0-1102.0
122	3700-3504	85	1115.5-1114.5
131	3067-2907	90	1126.2-1125.2
140	2554-2424	95	1136.6-1135.6
149	2149-2019	100	1147.2-1146.2
		105	1158.1-1157.1
		110	1168.8-1167.8
		115	1179.4-1178.4
		120	1190.1-1189.1
		125	1200.3-1199.3
		130	1212.2-1211.2

4/24/12

4/24/12

Antifreeze Corrections

Catalog performance can be corrected for antifreeze use. Please use the following table and note the example given.

Antifreeze Type	Antifreeze % by wt	Heating	Cooling	Pressure Drop
EWT - °F [°C]		30 [-1.1]	90 [32.2]	30 [-1.1]
Water	0	1.000	1.000	1.000
	10	0.973	0.991	1.075
Ethylene Glycol	20	0.943	0.979	1.163
	30	0.917	0.965	1.225
	40	0.890	0.955	1.324
	50	0.865	0.943	1.419
	10	0.958	0.981	1.130
Propylene Glycol	20	0.913	0.969	1.270
	30	0.854	0.950	1.433
	40	0.813	0.937	1.614
	50	0.770	0.922	1.816
	10	0.927	0.991	1.242
Ethanol	20	0.887	0.972	1.343
	30	0.856	0.947	1.383
	40	0.815	0.930	1.523
	50	0.779	0.911	1.639
	10	0.957	0.986	1.127
Methanol	20	0.924	0.970	1.197
	30	0.895	0.951	1.235
	40	0.863	0.936	1.323
	50	0.833	0.920	1.399



WARNING: Gray area represents antifreeze concentrations greater than 35% by weight and should be avoided due to the extreme performance penalty they represent.

Antifreeze Correction Example

Antifreeze solution is Propylene Glycol 20% by weight. Determine the corrected heating and cooling performance at 30°F and 90°F respectively as well as pressure drop at 30°F for a 036 operating at 100% capacity.

The corrected cooling capacity at 90°F would be: 35,200 Btu/h x 0.969 = 34,109 Btu/h

The corrected heating capacity at 30°F would be: 37,400 Btu/h x 0.913 = 34,146 Btu/h

The corrected pressure drop at 30°F and 11.5 gpm would be: 7.9 feet of head x 1.270 = 10.03 feet of head

Correction Factor Tables

Air Flow Corrections (Compressor Speeds 1-3)

Airflow		Cooling				Heating		
CFM Per Ton of Clg	% of Nominal	Total Cap	Sens Cap	Power	Heat of Rej	Htg Cap	Power	Heat of Ext
240	60	0.940	0.740	0.967	0.951	0.943	1.106	0.902
275	69	0.950	0.783	0.973	0.959	0.953	1.088	0.918
300	75	0.960	0.827	0.978	0.967	0.962	1.070	0.935
325	81	0.970	0.870	0.984	0.975	0.972	1.053	0.951
350	88	0.980	0.913	0.989	0.984	0.981	1.035	0.967
375	94	0.990	0.957	0.995	0.992	0.991	1.018	0.984
400	100	1.000	1.000	1.000	1.000	1.000	1.000	1.000
425	106	1.030	1.022	1.024	1.026	1.009	0.982	1.016
450	113	1.060	1.045	1.048	1.051	1.019	0.965	1.033
475	119	1.091	1.067	1.071	1.077	1.028	0.947	1.049
500	125	1.121	1.089	1.095	1.103	1.038	0.930	1.065
520	130	1.151	1.111	1.110	1.129	1.047	0.912	1.082

6/29/12

Air Flow Corrections (Compressor Speeds 4-12)

Airflow		Cooling				Heating		
CFM Per Ton of Clg	% of Nominal	Total Cap	Sens Cap	Power	Heat of Rej	Htg Cap	Power	Heat of Ext
240	60	0.928	0.747	0.936	0.929	0.961	1.097	0.938
275	69	0.940	0.789	0.946	0.941	0.967	1.081	0.948
300	75	0.952	0.831	0.957	0.953	0.974	1.064	0.959
325	81	0.964	0.873	0.968	0.965	0.980	1.048	0.969
350	88	0.976	0.916	0.979	0.976	0.987	1.032	0.979
375	94	0.988	0.958	0.989	0.988	0.993	1.016	0.990
400	100	1.000	1.000	1.000	1.000	1.000	1.000	1.000
425	106	1.020	1.023	1.004	1.018	1.010	0.966	1.018
450	113	1.056	1.042	1.008	1.035	1.020	0.932	1.036
475	119	1.072	1.079	1.011	1.053	1.029	0.898	1.054
500	125	1.087	1.095	1.015	1.070	1.039	0.865	1.071
520	130	1.099	1.113	1.019	1.088	1.049	0.831	1.089

6/14/12

Cooling Capacity Corrections

Entering Air WB °F	Total Clg Cap	Sensible Cooling Capacity Multipliers - Entering DB °F										Power Input	Heat of Rejection
		60	65	70	75	80	80.6	85	90	95	100		
55	0.898	0.723	0.866	1.048	1.185	*	*	*	*	*	*	0.985	0.913
60	0.912		0.632	0.880	1.078	1.244	1.260	*	*	*	*	0.994	0.927
63	0.945			0.768	0.960	1.150	1.175	*	*	*	*	0.996	0.954
65	0.976			0.694	0.881	1.079	1.085	1.270	*	*	*	0.997	0.972
66.2	0.983			0.655	0.842	1.040	1.060	1.232	*	*	*	0.999	0.986
67	1.000			0.616	0.806	1.000	1.023	1.193	1.330	1.480	*	1.000	1.000
70	1.053				0.693	0.879	0.900	1.075	1.205	1.404	*	1.003	1.044
75	1.168					0.687	0.715	0.875	1.040	1.261	1.476	1.007	1.141

NOTE: *Sensible capacity equals total capacity at conditions shown.

4/22/12

Heating Capacity Corrections

Ent Air DB °F	Heating Corrections		
	Htg Cap	Power	Heat of Ext
45	1.062	0.739	1.158
50	1.050	0.790	1.130
55	1.037	0.842	1.096
60	1.025	0.893	1.064
65	1.012	0.945	1.030
68	1.005	0.976	1.012
70	1.000	1.000	1.000
75	0.987	1.048	0.970
80	0.975	1.099	0.930

11/10/09

Compressor Resistance

Model	Compressor Model No.	Winding Resistance
		208-230/60/1
036	VRJ028UKNP6	0.255
048	VRJ035UKNP6	0.210
060	VRJ044UKNP6	0.210

4/23/12

VRJ scroll compressors are equipped with an IPM (permanent magnet motor). Winding resistance is the resistance between indicated terminal pins at 77°F (Resistance value ± 7%). Winding resistance is generally low and it requires adapted tools for precise measurement. Use a digital ohm-meter capable of connecting a 4 wire probe. Use the 4 Wire Kelvin method and measure resistances under stabilized ambient temperature. Winding resistance varies strongly with winding temperature; If the compressor is stabilized at a different value than 77°F, the measured resistance must be corrected with the following formula:

$$R_{t_{amb}} = R_{77°F} \frac{a + t_{amb}}{a + t_{77°F}}$$

$t_{77°F}$: reference temperature = 77°F

t_{amb} : temperature during measurement (°F)

$R_{77°F}$: winding resistance at 77°F

$R_{t_{amb}}$: winding resistance at t_{amb}

a : Coefficient a = 390

Refrigerant Circuit Guideline

Symptom	Head Pressure	Suction Pressure	Compressor Amp Draw	Superheat	Subcooling	Air Temp. Differential	Water Temp. Differential
Under Charged System (Possible Leak)	Low	Low	Low	High	Low	Low	Low
Over Charged System	High	High	High	Normal	High	Normal/Low	Normal
Low Air Flow Heating	High	High	High	High/Normal	Low	High	Low
Low Air Flow Cooling	Low	Low	Low	Low/Normal	High	High	Low
Low Water Flow Heating	Low/Normal	Low/Normal	Low	Low	High	Low	High
Low Water Flow Cooling	High	High	High	High	Low	Low	High
High Air Flow Heating	Low	Low	Low	Low	High	Low	Low
High Air Flow Cooling	Low	High	Normal	High	Low	Low	Normal
High Water Flow Heating	Normal	Low	Normal	High	Normal	Normal	Low
High Water Flow Cooling	Low	Low	Low	Low	High	Normal	Low
Low Indoor Air Temperature Heating	Low	Low	Low	Normal	High	Normal	Normal/High
Low Indoor Air Temperature Cooling	Low	Low	Low	Normal/Low	High	Low	Low
High Indoor Air Temperature Heating	High	High	High	Normal/High	Normal/Low	Low	Normal
High Indoor Air Temperature Cooling	High	High	High	High	Low	Low	High
Restricted EEV (Check Service Advisory)	High	Low	Normal/Low	High	High	Low	Low
Insufficient Compressor (Possible Bad Valves)	Low	High	Low	High	Normal/High	Low	Low
Scaled Coaxial Heat Exchanger Heating	Low	Low	Low	Normal/Low	High	Low	Low
Scaled Coaxial Heat Exchanger Cooling	High	High	High	Normal/Low	Low	Low	Low
Restricted Filter Drier	Check temperature difference (delta T) across filter drier.						

6/1/12

Heat of Extraction/Rejection

Model	GPM	Heat of Extraction (MBtuh)					GPM	Heat of Rejection (MBtuh)				
		30°F	50°F	70°F	90°F	30°F		50°F	70°F	90°F	110°F	
036	Full Load	5.5	22.5	32.5	41.7	49.1	4.5	39.1	44.1	42.8	40.3	37.9
		8.0	23.2	33.9	43.3	51.2	7.0	39.4	44.7	43.0	41.1	38.5
		11.5	23.8	34.8	44.7	53.1	9.0	39.8	45.1	43.2	41.4	39.0
048	Full Load	6.5	27.9	38.5	52.5	60.1	5.5	47.9	53.7	51.4	48.5	54.1
		10.0	30.6	42.6	55.9	66.9	8.0	48.2	53.9	51.7	48.9	45.9
		13.5	31.7	44.3	58.9	71.4	10.5	48.7	54.2	51.9	49.2	46.2
060	Full Load	8.5	33.5	48.4	63.9	83.0	6.5	66.9	70.8	69.0	64.1	58.7
		13.0	36.9	51.9	68.4	84.3	10.0	67.3	71.2	69.2	64.3	59.2
		17.0	37.3	53.1	70.5	87.9	13.5	68.0	71.7	69.5	64.7	59.4

Note: operation not recommended in shaded areas.

1/12/2021

Operating Parameters

Model 060 - Comp Speed 9 (1800 cfm)

Entering Water Temp °F	Water Flow	Cooling -- No Hot Water Generation					
		Suction Pressure psig	Discharge Pressure psig	Superheat	Subcooling	Water Temp Rise °F	Air Temp Drop °F DB
30	13.5	122-127	162-172	20-24	5-10	8-12	19-25
50	13.5	138-143	215-225	6-10	6-11	8-12	19-25
70	13.5	143-148	280-290	6-10	8-12	8-12	19-25
90	13.5	147-152	357-367	6-10	11-15	8-12	17-22
110	13.5	149-154	450-460	6-10	15-19	8-12	17-22

Model 060 - Comp Speed 12 (2200 cfm)

Entering Water Temp °F	Water Flow	Heating - No Hot Water Generation					
		Suction Pressure psig	Discharge Pressure psig	Superheat	Subcooling	Water Temp Drop °F	Air Temp Rise °F DB
30	17.0	80-85	345-355	6-10	15-20	4-8	20-26
50	17.0	111-116	350-360	6-10	10-15	4-8	24-30
70	17.0	153-158	395-405	6-10	13-18	6-10	32-38
90	17.0	188-193	440-450	8-12	18-23	8-12	39-45

Model 048 - Comp Speed 9 (1400 cfm)

Entering Water Temp °F	Water Flow	Cooling -- No Hot Water Generation					
		Suction Pressure psig	Discharge Pressure psig	Superheat	Subcooling	Water Temp Rise °F	Air Temp Drop °F DB
30	10.5	123-128	150-160	17-22	9-14	8-13	19-25
50	10.5	140-145	190-200	10-14	4-9	8-13	19-25
70	10.5	142-147	260-270	10-14	6-11	8-13	18-24
90	10.5	143-148	343-348	10-14	8-13	7-12	17-23
110	10.5	145-150	440-450	10-14	10-15	7-12	17-23

Model 048 - Comp Speed 12 (1800 cfm)

Entering Water Temp °F	Water Flow	Heating - No Hot Water Generation					
		Suction Pressure psig	Discharge Pressure psig	Superheat	Subcooling	Water Temp Drop °F	Air Temp Rise °F DB
30	13.5	75-80	321-331	6-10	15-20	4-8	20-25
50	13.5	108-113	345-355	6-10	15-20	5-9	28-33
70	13.5	145-150	400-410	7-12	10-15	8-12	34-39
90	13.5	183-188	450-460	11-16	12-18	9-13	31-36

Model 036 - Comp Speed 9 (1300 cfm)

Entering Water Temp °F	Water Flow	Cooling -- No Hot Water Generation					
		Suction Pressure psig	Discharge Pressure psig	Superheat	Subcooling	Water Temp Rise °F	Air Temp Drop °F DB
30	9	114-119	142-152	17-25	8-13	6-10	15-20
50	9	135-140	198-208	5-10	5-10	6-10	20-25
70	9	142-148	268-275	5-10	5-10	6-10	20-25
90	9	147-152	345-355	5-10	9-14	6-10	18-23
110	9	153-158	445-455	5-10	9-14	5-9	16-21

Model 036 - Comp Speed 12 (1500 cfm)

Entering Water Temp °F	Water Flow	Heating - No Hot Water Generation					
		Suction Pressure psig	Discharge Pressure psig	Superheat	Subcooling	Water Temp Drop °F	Air Temp Rise °F DB
30	11.5	80-85	288-298	6-10	6-11	3-7	17-22
50	11.5	115-120	315-325	6-10	6-11	4-9	23-28
70	11.5	158-163	345-355	5-9	4-9	4-9	30-35
90	11.5	189-194	425-435	13-18	5-10	7-11	35-40

11/21/2017

Reference Calculations

Heating Calculations:	Cooling Calculations:
$LWT = EWT - \frac{HE}{gpm \times 500}$	$LWT = EWT + \frac{HR}{gpm \times 500}$
$LAT = EAT + \frac{HC}{cfm \times 1.08}$	$LAT (DB) = EAT (DB) - \frac{SC}{cfm \times 1.08}$
$TH = HC + HW$	$LC = TC - SC$
	$S/T = \frac{SC}{TC}$

Legend

Abbreviations and Definitions

cfm	= airflow, cubic feet/minute
EWT	= entering water temperature, Fahrenheit
gpm	= water flow in gallons/minute
WPD	= water pressure drop, psi and feet of water
EAT	= entering air temperature, Fahrenheit (dry bulb/wet bulb)
HC	= air heating capacity, MBtu/h
TC	= total cooling capacity, MBtu/h
SC	= sensible cooling capacity, MBtu/h
kW	= total power unit input, kilowatts
HR	= total heat of rejection, MBtu/h
HE	= total heat of extraction, MBtu/h
HWC	= hot water generator capacity, MBtu/h
EER	= Energy Efficient Ratio
	= Btu output/Watt input
COP	= Coefficient of Performance
	= Btu output/Btu input
LWT	= leaving water temperature, °F
LAT	= leaving air temperature, °F
TH	= total heating capacity, MBtu/h
LC	= latent cooling capacity, MBtu/h
S/T	= sensible to total cooling ratio

Troubleshooting

Aurora Control System

NOTE: Refer to the Aurora Base Control Application and Troubleshooting Guide and the Instruction Guide: Aurora Interface and Diagnostics (AID) Tool for additional information.

To check the unit control board for proper operation:

- General Check
 - If any new device was installed, or any wiring was changed, check the connections to ensure the wiring is correct, and all the wires are in good condition.
 - Verify all the plugs are securely connected and in good condition.
 - Check the DIP switch (SW2) positions are correct.
 - Measure 24 VAC between R and C. (The actual reading may be from 18 to 30 VAC). Check the incoming power and the power transformer if the R and C voltage reading is not correct.
- No LEDs are On
 - Check 24 VAC on board.
 - Check the 3 amp fuse. Replace the fuse if needed.
 - Verify transformer circuit breaker has not tripped if no low voltage is present.
 - Disconnect the thermostat connection P1.
 - Replace the Aurora base control board.

Refrigerant Systems

Refrigerant pressures are monitored by the control system; to maintain sealed circuit integrity, do not install service gauges unless pressure sensor is suspected to be inoperative. Compare the change in temperature on the air side as well as the water side to the Unit Operating Parameters tables. If the unit's performance is not within the ranges listed, make sure the airflow and water flow are correct. Check superheat and subcooling with an AID Tool. If superheat and subcooling are outside recommended ranges, an adjustment to the refrigerant charge may be necessary.

NOTE: Refrigerant tests must be made with hot water generator turned "OFF". Verify that air and water flow rates are at proper levels before servicing the refrigerant circuit.

Troubleshooting cont.

Sensor Locations

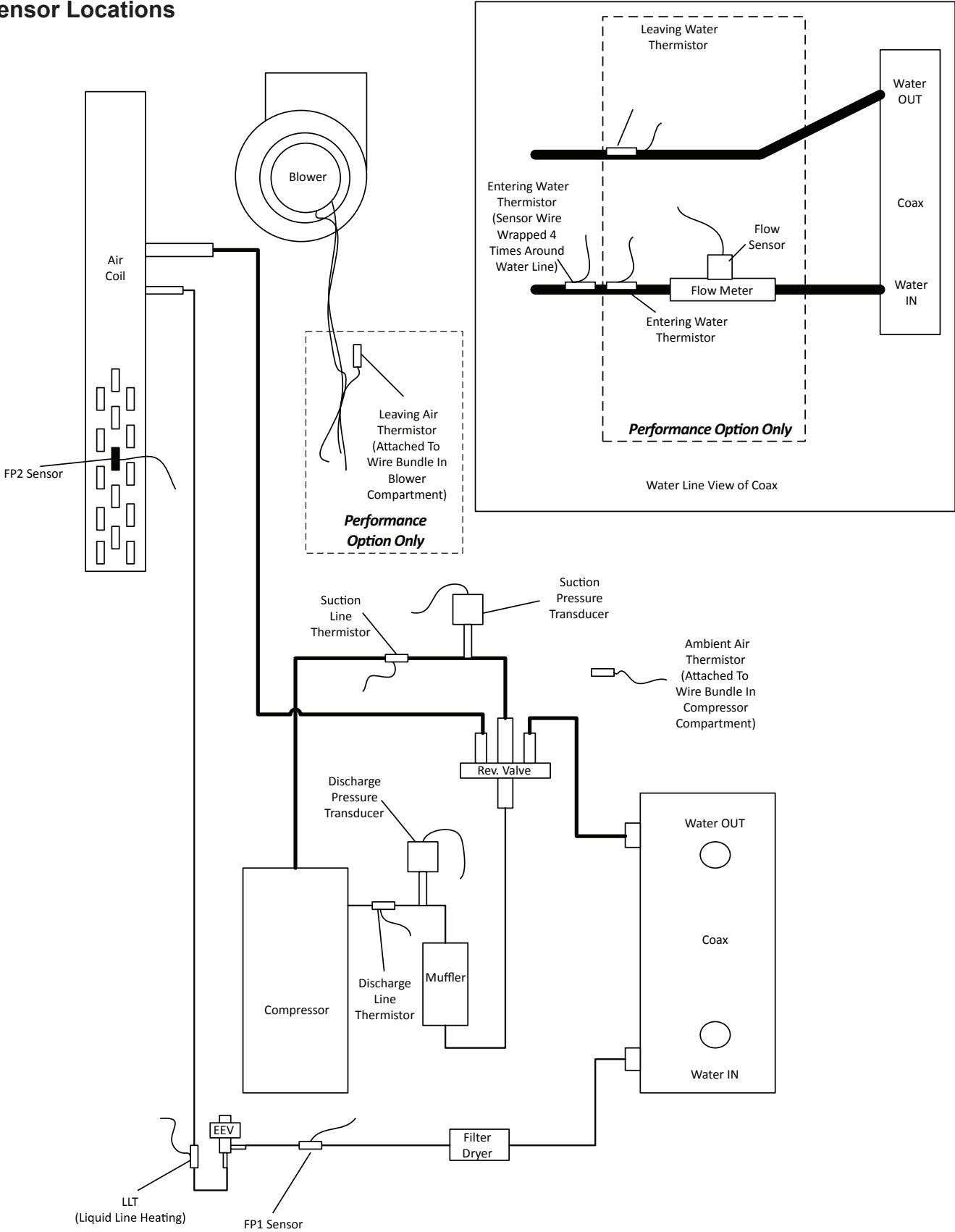

Startup/Troubleshooting Form

Dealer: _____
 Phone #: _____ Date: _____
 Problem: _____
 Model #: _____
 Serial #: _____

Controls Info:
 ABC Version: _____
 AXB Version: _____
 IZ2 Version: _____
 T-Stat Version: _____
 Installed Sensors: _____

COOLING CYCLE ANALYSIS

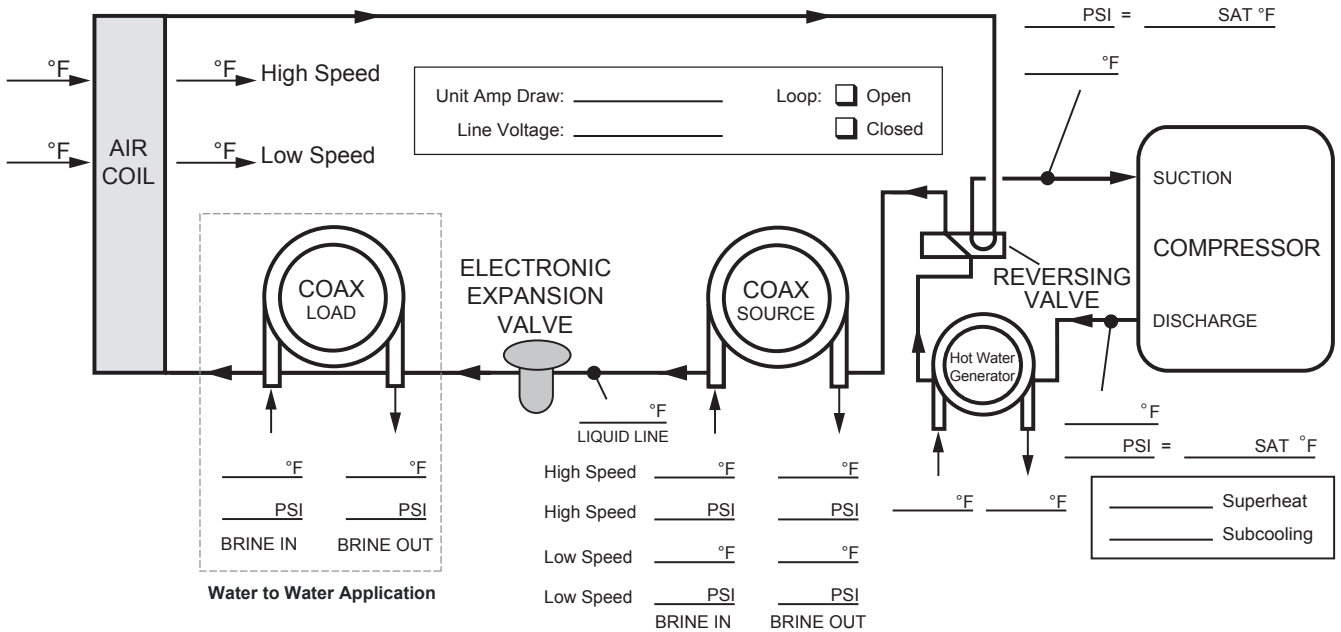

Heat of Extraction/Rejection = gpm x 500 (485 for water/antifreeze) x ΔT

Note: DO NOT hook up pressure gauges unless pressure sensors are suspect.

HEATING CYCLE ANALYSIS

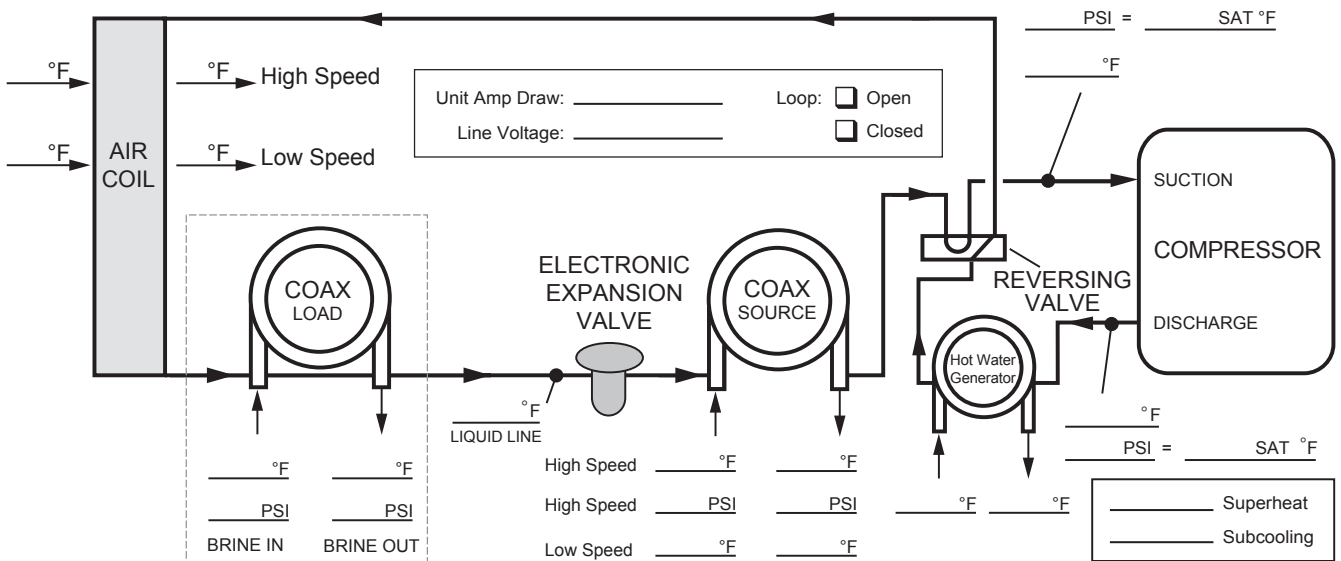

Troubleshooting cont.

Variable Speed Startup/Troubleshooting Form

1. Job Information

Model # _____ Job Name: _____ Loop: Open / Closed
 Serial # _____ Install Date: _____ Hot Water Generator: Y / N

2. Flow Rate in gpm

SOURCE COAX

	HEATING SPEED 12	HEATING SPEED 4	COOLING SPEED 9	COOLING SPEED 3
WATER IN Pressure:	a. _____ psi	a. _____ psi	a. _____ psi	a. _____ psi
WATER OUT Pressure:	b. _____ psi	b. _____ psi	b. _____ psi	b. _____ psi
Pressure Drop: a - b	c. _____ psi	c. _____ psi	c. _____ psi	c. _____ psi
Look up flow rate in table:	d. _____ gpm	d. _____ gpm	d. _____ gpm	d. _____ gpm

3. Temperature Rise/Drop Across Coaxial Heat Exchanger¹

	HEATING SPEED 12	HEATING SPEED 4	COOLING SPEED 9	COOLING SPEED 3
WATER IN Temperature:	e. _____ °F	e. _____ °F	e. _____ °F	e. _____ °F
WATER OUT Temperature:	f. _____ °F	f. _____ °F	f. _____ °F	f. _____ °F
Temperature Difference:	g. _____ °F	g. _____ °F	g. _____ °F	g. _____ °F

4. Temperature Rise/Drop Across Air Coil

	HEATING SPEED 12	HEATING SPEED 4	COOLING SPEED 9	COOLING SPEED 3
SUPPLY AIR Temperature:	h. _____ °F	h. _____ °F	h. _____ °F	h. _____ °F
RETURN AIR Temperature:	i. _____ °F	i. _____ °F	i. _____ °F	i. _____ °F
Temperature Difference:	j. _____ °F	j. _____ °F	j. _____ °F	j. _____ °F

5. Heat of Rejection (HR)/Heat of Extraction (HE)

Brine Factor²: k. _____

	HEATING SPEED 12	HEATING SPEED 4	COOLING SPEED 9	COOLING SPEED 3
HR/HE = d x g x k	l. _____ Btu/h	l. _____ Btu/h	l. _____ Btu/h	l. _____ Btu/h

STEPS 6-9 NEED ONLY BE COMPLETED IF A PROBLEM IS SUSPECTED. USE HEATING SPEED 12 AND COOLING SPEED 9 FOR STEPS 6-9.

6. Watts

ENERGY MONITOR

	HEATING SPEED 12	COOLING SPEED 9
Volts:	m. _____ Volts	m. _____ Volts
Total Amps (Comp. + Blower) ³ :	n. _____ Amps	n. _____ Amps
Watts = m x n x 0.85:	o. _____ Watts	o. _____ Watts

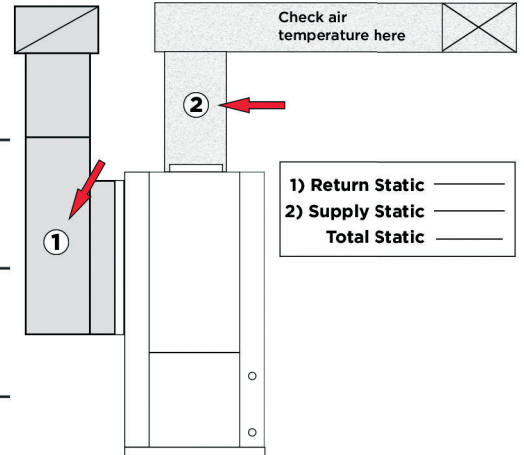

7. Capacity

	HEATING SPEED 12	COOLING SPEED 9
Cooling Capacity = l - (o x 3.413):	p. _____ Btu/h	p. _____ Btu/h
Heating Capacity = l + (o x 3.413):	p. _____ Btu/h	p. _____ Btu/h

8. Efficiency

	HEATING SPEED 12	COOLING SPEED 9
Cooling EER = p / o:	q. _____ Btu/h	q. _____ Btu/h
Heating COP = p / (o x 3.413):	q. _____ Btu/h	q. _____ Btu/h

9. Superheat (S.H.)/Subcooling (S.C.)

	HEATING SPEED 12	COOLING SPEED 9
Suction Pressure:	r. _____ psi	r. _____ psi
Suction Saturation Temperature:	s. _____ °F	s. _____ °F
Suction Line Temperature:	t. _____ °F	t. _____ °F
S.H. = t - s	u. _____ °F	u. _____ °F
Head Pressure:	v. _____ psi	v. _____ psi
High Pressure Saturation Temp:	w. _____ °F	w. _____ °F
Liquid Line Temperature ⁴ :	x. _____ °F	x. _____ °F
S.C. = w - x	y. _____ °F	y. _____ °F

Software Version	
ABC:	_____
AXB:	_____
IZ2:	_____
TSTAT:	_____

NOTES: ¹ Steps 3-9 should be conducted with the hot water generator disconnected.

² Use 500 for pure water, 485 for methanol or Environol™. (This constant is derived by multiplying the weight of one gallon of water (8.34) times the minutes in one hour (60) times the specific heat of the fluid. Water has a specific heat of 1.0.

³ If there is only one source of power for the compressor and blower, amp draw can be measured at the source wiring connection.

⁴ Liquid line is between the coax and the expansion device in the cooling mode; between the air coil and the expansion device in the heating mode.

Preventive Maintenance

Water Coil Maintenance

1. Keep all air out of the water. An open loop system should be checked to ensure that the well head is not allowing air to infiltrate the water line. Lines should always be airtight.
2. Keep the system under pressure at all times. It is recommended in open loop systems that the water control valve be placed in the discharge line to prevent loss of pressure during off cycles. Closed loop systems must have positive static pressure.

NOTE: On open loop systems, if the installation is in an area with a known high mineral content (125 PPM or greater) in the water, it is best to establish with the owner a periodic maintenance schedule so the coil can be checked regularly. Should periodic coil cleaning be necessary, use standard coil cleaning procedures which are compatible with either the cupronickel or copper water lines. Generally, the more water flowing through the unit the less chance for scaling.

Other Maintenance

Filters

Air filters and variable speed drive filter must be clean to obtain maximum performance. They should be inspected monthly under normal operating conditions and be replaced when necessary. Units should never be operated without a filter. The VS drive filter is located on the lower left corner of the cabinet. Removing the two screws in the honey comb grill allows access to the filter. Run the filter under warm water and gently rub. Let the filter dry. The, re-install the filter and cover.

Condensate Drain

In areas where airborne bacteria produce a slime in the drain pan, it may be necessary to treat chemically to minimize the problem. The condensate drain can pick up lint and dirt, especially with dirty filters. Inspect twice a year to avoid the possibility of overflow.

Blower Motors

ECM blower motors are equipped with sealed ball bearings and require no periodic oiling.

Hot Water Generator Coil

See Water Coil Maintenance section above.

Air Coil

The air coil must be cleaned to obtain maximum performance. Check once a year under normal operating conditions and, if dirty, brush or vacuum (with a brush attachment) clean. Care must be taken not to damage the aluminum fins while cleaning.



CAUTION: Fin edges are sharp.

Replacement Procedures

Obtaining Parts

When ordering service or replacement parts, refer to the model number and serial number of the unit as stamped on the serial plate attached to the unit. If replacement parts are required, mention the date of installation of the unit and the date of failure, along with an explanation of the malfunctions and a description of the replacement parts required.

In-Warranty Material Return

Material may not be returned except by permission of authorized warranty personnel. Contact your local distributor for warranty return authorization and assistance.

Service Parts List

Parts List - Vertical		036	048	060	
Compressor	Compressor 208-230/60/1	34P647-01	34P648-01	34P649-01	
	Sound Jacket	92P504A05	92P504A05	92P504A05	
	Power Harness	11P853-01	11P853-01	11P853-01	
ECM Motor & Blower	ECM Motor 208-230/60/1	14S575-01	14S576-01	14S577-01	
	ECM Blower Housing	53P501B01	53P501B01	53P501B01	
	ECM Harness - Low Voltage	11P827-02	11P827-02	11P827-02	
	ECM Power Harness	11P585B03	11P585B03	11P585B03	
Air Filters	2" Air Filter MERV 11 (top flow & rear discharge)	59P509-07	59P509-07	59P509-06	
	2" Air Filter MERV 11 (bottom flow)	59P509-06	59P509-06	59P509-06	
	AP411 4" Media Refill	RM-AP411-46	RM-AP411-46	RM-AP411-46	
	AP411 1" Carbon Media Refill	RM-AP411-46C	RM-AP411-46C	RM-AP411-46C	
Refrigeration Components	Air Coil	61P773-41S	61P773-41S	61P772-41S	
	Coax	62I628-01	62I555-01	62I555-01	
	EEV	33P617-01	33P617-01	33P617-01	
	Reversing Valve	33P526-05	33P526-05	33P526-05	
	Discharge Muffler	36P503B02	36P503B02	36P503B02	
	Filter Dryer	36P500B01	36P500B02	36P500B02	
	Hot Water Generator				
Hot Water Generator	Hot Water Generator	62P516-03	62P516-03	62P516-03	
Hot Water Generator	Hot Water Generator Pump	24P501A01	24P501A01	24P501A01	
Electrical	Contactors	13P004A03	13P004A03	13P004A03	
	Transformer 208-230/60/1	15P501B01	15P501B01	15P501B01	
	3 Pole Power Block	12P503-06	12P503-06	12P503-06	
	2 Pole Screw Term. Block	12P500A01	12P500A01	12P500A01	
	EEV Solenoid Coil	33P617-02	33P617-02	33P617-02	
	EEV/VS Drive Communication Cable	11P843-01	11P843-01	11P843-01	
	ABC/AXB/VS Drive Communication Cable	11P836-01	11P836-01	11P836-01	
	Keystone Category 5 Coupler (AID Port)	12P553-01	12P553-01	12P553-01	
	Category 5 cable (AID Port to ABC)	11P846-01	11P846-01	11P846-01	
	Current Transformer	12P557-01	12P557-01	12P557-01	
	Rocker Switch - HWG ON/OFF	13P607A01	13P607A01	13P607A01	
	Pump Circuit Breaker - 5 amp, 250v	19P583-01	19P583-01	19P583-01	
	Pressure Transmitter DIN Cable	11P855-01	11P855-01	11P855-01	
	VS Drive Control	17P560-04	17P560-05	17P560-06	
	Drive Circuit Breaker	19P595-01	19P595-02	19P595-03	
	EEV Board	17P561-01	17P561-01	17P561-01	
	ABC Board	17X553-02	17X553-02	17X553-02	
	AXB Board	17P557-01	17P557-01	17P557-01	
	Sensors & Safeties	Freeze Detection Thermistor-FP1-Yellow	12P505-09	12P505-09	12P505-09
		HWL Thermistor-Pink (AXB P17)	12P555-04	12P555-04	12P555-04
Thermistor FP2		12P550-01	12P550-01	12P550-01	
Thermistor - LAT/EWT/Suct Line/ Compr Ambient		12P556-01	12P556-01	12P556-01	
Thermistor - Compressor Discharge Line		12P556-02	12P556-02	12P556-02	
Thermistor - Heating Liquid Line		12P555-03	12P555-03	12P555-03	
Thermistor - Leaving Water Temperature		12P555-02	12P555-02	12P555-02	
Transmitter, Flow Meter (sensor, clip, harness)		29P535-01	29P535-01	29P535-01	
Pressure Transmitter Replacement, High Pressure		SK7SHPT	SK7SHPT	SK7SHPT	
Pressure Transmitter Replacement, Low Pressure		SK7SLPT	SK7SLPT	SK7SLPT	
Switch, High Pressure		SKHPE600	SKHPE600	SKHPE600	
Switch, Low Pressure		SKLPE40	SKLPE40	SKLPE40	
Misc.		VS Drive Fan Filter	59P512-01	59P512-01	59P512-01

Part numbers subject to change

10/28/20

Parts List - Horizontal		036	048	060	
Compressor	Compressor 208-230/60/1	34P647-01	34P648-01	34P649-01	
	Sound Jacket	92P504A05	92P504A05	92P504A05	
	Power Harness	11P853-01	11P853-01	11P853-01	
ECM EON Motor & Blower	ECM Motor 208-230/60/1	14S575-01	14S576-01	14S577-01	
	ECM Blower Housing	53P501B01	53P501B01	53P501B01	
	ECM Harness - Low Voltage	11P827-01	11P827-01	11P827-01	
	ECM Power Harness	11P585B04	11P585B04	11P585B04	
Air Filters	2" Air Filter MERV 11	59P509-02	59P509-02	59P509-03	
	2" Air Filter MERV 11 (second filter if needed)	59P509-11	59P509-11	59P509-11	
	Air Coil	61P775-41S	61P775-41S	61P776-41S	
Refrigeration Components	Coax	62I628-01	62I555-01	62I555-01	
	EEV	33P617-01	33P617-01	33P617-01	
	Reversing Valve	33P526-05	33P526-05	33P526-05	
	Discharge Muffler	36P503B02	36P503B02	36P503B02	
	Filter Dryer	36P500B01	36P500B02	36P500B02	
	Hot Water Generator	Hot Water Generator	62P516-03	62P516-03	62P516-03
	Hot Water Generator	Hot Water Generator Pump	24P501A01	24P501A01	24P501A01
Electrical	Contactors	13P004A03	13P004A03	13P004A03	
	Transformer 208-230/60/1	15P501B01	15P501B01	15P501B01	
	3 Pole Power Block	12P503-06	12P503-06	12P503-06	
	2 Pole Screw Term. Block	12P500A01	12P500A01	12P500A01	
	EEV Solenoid Coil	33P617-02	33P617-02	33P617-02	
	EEV/VS Drive Communication Cable	11P843-01	11P843-01	11P843-01	
	ABC/AXB/VS Drive Communication Cable	11P836-01	11P836-01	11P836-01	
	Keystone Category 5 Coupler (AID Port)	12P553-01	12P553-01	12P553-01	
	Category 5 cable (AID Port to ABC)	11P846-01	11P846-01	11P846-01	
	Current Transformer	12P557-01	12P557-01	12P557-01	
	Rocker Switch - HWG ON/OFF	13P607A01	13P607A01	13P607A01	
	Pump Circuit Breaker - 5 amp, 250v	19P583-01	19P583-01	19P583-01	
	Pressure Transmitter DIN Cable	11P855-01	11P855-01	11P855-01	
	VS Drive Control	17P560-04	17P560-05	17P560-06	
	Drive Circuit Breaker	19P595-01	19P595-02	19P595-03	
	EEV Board	17P561-01	17P561-01	17P561-01	
	ABC Board	17P553-02	17P553-02	17P553-02	
	AXB Board	17P557-01	17P557-01	17P557-01	
	Sensors & Safeties	Freeze Detection Thermistor-FP1-Yellow	12P505-09	12P505-09	12P505-09
		HWL Thermistor-Pink (AXB P17)	12P555-04	12P555-04	12P555-04
Thermistor FP2		12P550-01	12P550-01	12P550-01	
Thermistor - LAT/EWT/Suct Line/ Compr Ambient		12P556-01	12P556-01	12P556-01	
Thermistor - Compressor Discharge Line		12P556-02	12P556-02	12P556-02	
Thermistor - Heating Liquid Line		12P555-03	12P555-03	12P555-03	
Thermistor - Leaving Water Temperature		12P555-02	12P555-02	12P555-02	
Transmitter, Flow Meter (sensor, clip, harness)		29P535-01	29P535-01	29P535-01	
Pressure Transmitter Replacement, High Pressure		SK7SHPT	SK7SHPT	SK7SHPT	
Pressure Transmitter Replacement, Low Pressure		SK7SLPT	SK7SLPT	SK7SLPT	
Switch, High Pressure		SKHPE600	SKHPE600	SKHPE600	
Switch, Low Pressure		SKLPE40	SKLPE40	SKLPE40	
Misc		VS Drive Fan Filter	59P512-01	59P512-01	59P512-01

Part numbers subject to change

10/28/20

Revision Guide

Pages:	Description:	Date:	By:
Misc.	Updated Aluminum Air Coil	04 Dec 2020	MA
Misc.	Updated Schematics, General Installation Information, Unit Startup (UPMXL)	12 Sept 2019	MA
Misc	Updated Schematics, Service Parts, Control Sections (Added UPC Control Option)	21 Nov 2017	MA
All	Misc Updates	9 Dec 2016	MA
All	Electric heating updates, multiple areas effected.	20 April 2015	MA
9	Updated Primary/Secondary Pump Wiring Diagram	26 Jun 2013	DS
10	Updated Open Loop Water Valve Information	26 Jun 2013	DS
22 - 29	Updated Aurora Controls Information	26 Jun 2013	DS
32 - 35	Updated Wiring Diagram	26 Jun 2013	DS
40	Updated Operating Parameters Table (Model 036)	26 Jun 2013	DS
46	Updated Service Parts List	26 Jun 2013	DS
47	Added Revision Guide	26 Jun 2013	DS



Manufactured by
WaterFurnace International, Inc.
9000 Conservation Way
Fort Wayne, IN 46809
www.waterfurnace.com

Product: **7 Series 700A11**
Type: Geothermal Heat Pump
Size: 3-5 Ton Variable Speed
Document: Installation Manual

