

COLD WALL MILK COOLERS

Model: MC4NSCW

Natural Refrigerant R-290 Model

49" Cold Wall Milk Cooler Single Access



ENERGY STAR® Qualified Commercial Refrigerator

White painted steel exterior, stainless steel top and door, heavy-duty stainless steel lid(s), door hinges and latches, galvanized steel interior with reinforced stainless steel floor. **Designed to keep milk cold during serving.**



Options and Accessories

(upcharge and lead times may apply)

| | |
|--------------------------|-----------------------|
| Stainless steel exterior | Foot pedal floor lock |
| Stainless steel interior | Color laminate |
| Wrap around bumpers | Powder coating |
| Corner bumpers | Dual access |

Consult factory for other model configurations, options and accessories.

Continental
Refrigerator

Toll-Free: 800-523-7138
Phone: 215-244-1400
Fax: 215-244-9579

539 Dunksferry Road
Bensalem, PA 19020
www.continentalrefrigerator.com

Project Name:

Model Specified:

Location:

Item No:

Quantity:

AIA #:

SIS #:

Standard Model Features

REFRIGERATION SYSTEM

Cold wall, performance rated refrigeration system

Natural, environmentally safe,
high efficiency R-290 refrigerant¹

Easily serviceable, bottom-mounted condensing unit

CABINET ARCHITECTURE

2" high density, non-CFC polyurethane
foamed-in-place insulation

Snap in lid and door gasket

Non-corrosive, heavy duty, epoxy coated
steel wire floor racks

Cylinder keyed security lock

5" diameter swivel plate casters with front locking brakes

MODEL FEATURES

Electronic controller with digital display & hi-low alarm

Floor drain

¹ R-290 refrigerant meets all federal and state regulatory requirements.

APPROVAL:

Model Specifications

DIMENSIONAL DATA

| | |
|--|------------------|
| Net Capacity (cubic feet) | 20.0 (566 cu l) |
| Crate Capacity (13" x 13" x 11") | 12 |
| Crate Capacity (19" x 13" x 11") | 8 |
| Width, Overall (inches) | 49 (1245 mm) |
| Depth, Overall (inches) | 33 (838 mm) |
| Height, Overall (inches) (including 5" casters) | 41 1/2 (1054 mm) |

REFRIGERANT DATA

| | |
|-----------------------------|------|
| Condensing Unit Size (H.P.) | 1/3+ |
| Capacity (BTU per hour)* | 1725 |

ELECTRICAL DATA

| | |
|--|---------------------|
| Voltage (International) | 115/60/1 (220/50/1) |
| Total Amps (International) | 5.0 (2.9) |
| 10 ft. Cord/Plug [attached] (International) | Yes (No) |

SHIPPING DATA

| | |
|--------------------------|------------------|
| Weight (pounds) | 470 (213 kg) |
| Height - Crated (inches) | 56 1/4 (1429 mm) |
| Width - Crated (inches) | 58 1/4 (1480 mm) |
| Depth - Crated (inches) | 36 1/2 (927 mm) |

* Rating @ +10°F evaporator, 90°F ambient
Figures in parentheses reflect metric equivalents rounded to the nearest whole unit.



Equipped with one NEMA-5-15P Plug
(varies by country)

Model Plan Views

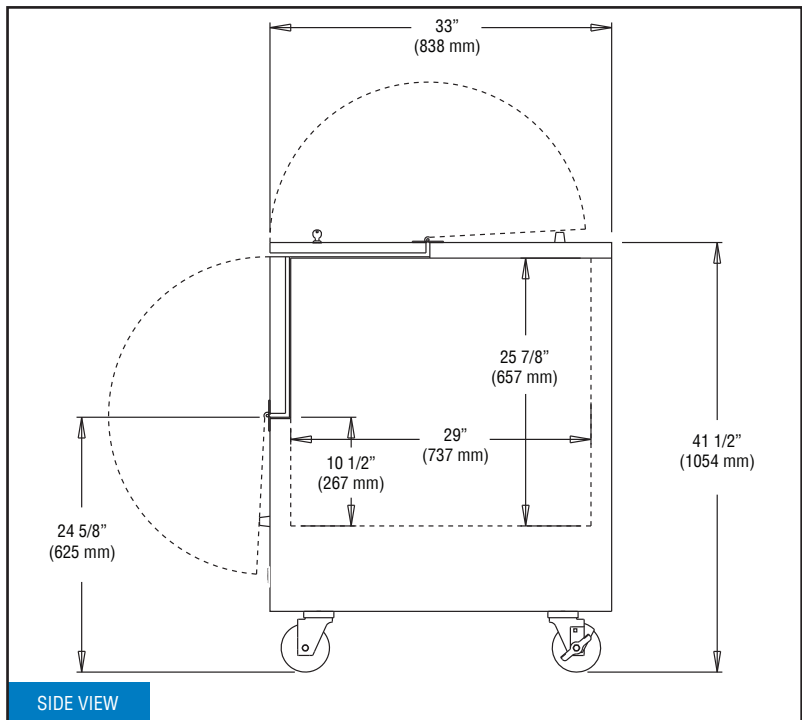
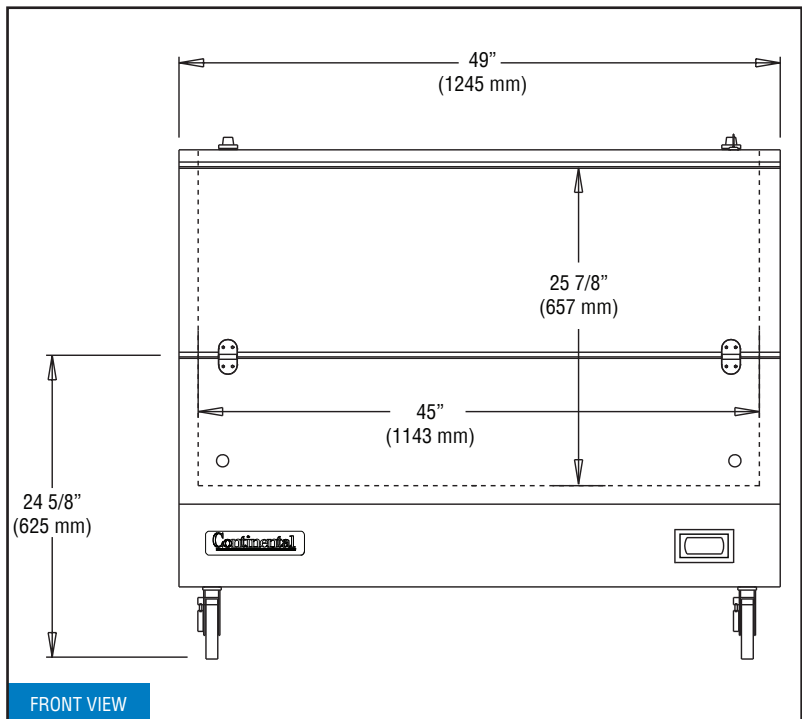

Continental
Refrigerator

Toll-Free: 800-523-7138
Phone: 215-244-1400
Fax: 215-244-9579

539 Dunksferry Road
Bensalem, PA 19020
www.continentalrefrigerator.com

Due to our continued efforts in developing innovative products, specifications subject to change without notice.



© Copyright 2021. Continental Refrigerator.
A Division of National Refrigeration & Air Conditioning Products, Inc.

REVISED: 7/20/2022