



Product Guide

EFFECTIVE JULY 1, 2018

BCPPGAUS

Belt Conveyor Products



10 Solent Circuit

Baulkham Hills NSW 2153

Phone: +61 2-8818-2000 Fax: +61 2-8824-6333

Toll Free: 1300 098 435

E-mail: salesau@flexco.com

www.flexco.com

INFORMATION

HEAD OFFICE ADDRESS: Flexco® (Aust.) Pty Ltd
10 Solent Circuit
Baulkham Hills, NSW 2153

OFFICE TELEPHONE: +61 2 8818-2000

WESTERN AUSTRALIA OFFICE ADDRESS: Unit 1/13 Ernest Clark Rd.
Canning Vale, WA 6155
Phone: 08 9456 2521
Fax: 08 9456 2571

BUNDABERG OFFICE ADDRESS: 49 Hanbury Street, Bundaberg, QLD
4670 Australia
Ph: 07 4151-0359
F: 07 4151-0568

POSTAL ADDRESS: P.O. Box 6365
Baulkham Hills B.C. NSW 2153

EMAIL: salesau@flexco.com
marketingau@flexco.com

OFFICE FACSIMILE: +612 8824-6333

TERMS AND CONDITIONS: Prices are in AUD exclusive of GST.

1. Stock items (non-shaded) please refer to asterisk (*) for specific lead time, if not specified, standard 2-3 days lead-time applies.
2. Some assembled items and larger quantities may take longer, please contact Flexco for specifics.
3. Non-stock items (shaded) please contact Flexco for dispatch options and lead times.
4. Minimum order size for free shipping is \$4,000.00 net.
5. Strictly Net 30 days unless otherwise negotiated.
6. 3rd party deliveries may be refused—please contact customer service.
7. Flexco endeavours to hold adequate stock levels at all times, however fluctuations do occur; stock is subject to availability.

LIMITED LIABILITY: Every effort is made to ensure the information contained in this price book is accurate and in accordance with all current specifications, however the company cannot be held responsible for any errors and reserves the right, without prior notice, to change specifications, quantities, and prices.

Visit our Web site at: www.flexco.com

Table of Contents

Belt Cleaners

Belt Cleaner Information and Selection Guide 5

Primary Cleaners

EZP-LS Limited Space Primary Cleaner	10
EZP1 Primary Cleaner & ConShear™ Replacement Blades	15
EZP1T Twist Tensioner Primary Cleaner	20
Spring Covers and Tensioner Lock	22
MMP Medium-Duty Primary Cleaner & TuffShear™ Replacement Blades	23
Line Connections for Portable Air Tensioner	29
MHCP Heavy-Duty Cartridge Primary Cleaner & SuperShear™ Replacement Blades	30
H-Type® Primary Cleaners.....	36
H-Type® ESAC Heavy-Duty Primary Cleaner.....	43
H-Type® ESAC with Extra Life -V-Tips Heavy-Duty Primary Cleaner.....	49

Secondary Cleaners

Y-Type® Secondary Cleaners.....	56
P-Type® Secondary Cleaners	63
R-Type® Reversing Secondary Cleaners	65
FMS Medium-Duty Secondary Cleaners	67
MHS Heavy-Duty Secondary Cleaners.....	80
Spring Covers and Tensioner Lock	79
Cartridge Cleaners:	
P-Type Secondary Cleaners with Service Advantage Cartridge™.....	80
R-Type Secondary Cleaners with Service Advantage Cartridge.....	87
MHS Heavy-Duty Secondary Cleaners with Service Advantage Cartridge	94
Spring Covers and Tensioner Lock	107
U-Type® Secondary Cleaners	108
Motorised Brush Cleaner	114
Chevron Belt Cleaner	117
Wash Box.....	118

Belt Cleaner Accessories

Inspection Doors.....	119
Spray Pole Systems.....	121
Mandrel Safety Removal System.....	123
Live Shaft Hold Down Rollers	124
Standard Pulley Lifter.....	125
Belt Cleaner Accessories.....	126
Optional Mounting Kits	127

Impact Beds

Flexco® Slider and Impact Beds

EZSB-C and EZSB-I Slider Beds; EZIB-L and EZIB-M Impact Beds	129
--	-----

DRX® Impact Beds

DRX200 - DRX1500 Impact Beds.....	138
DRX3000 Dynamic Bed.....	141
Optional Parts and Tools.....	142

Belt Conveyor Products

Ploughs

V-Plough	143
Twin Pole V-Plough.....	145
HD® Floating V-Plough	147
Diagonal Plough	149
HD Spring-Tensioned Diagonal Plough.....	150

Table of Contents

Belt Positioners and Trainers

Belt Positioner™	151
PTEZ	153
PT Smart™ Belt Trainer	157
PT Pro.....	160
PT Max™ Belt Trainer	163

Skirting Systems

Skirt Clamps-RMC1, Flex-Lok™, and FlexSeal™	166
Standard Urethane Skirting	168

Belt Maintenance Tools

Flex-Lifter™	169
Electric and Pneumatic Belt Cutters	169

Index	170
--------------------	------------

Belt Cleaner Information and Selection Guide

Why Are Belt Cleaners Needed?

- **Reduces Maintenance Costs**
 - Minimises manual cleanup.
 - Protects against belt mistracking.
 - Reduces conveyor component replacement costs.
 - Reducing carryback means a reduction in maintenance costs.
- **Improves Safety**
 - Reduces housekeeping problems.
 - A majority of conveyor-related accidents happen while maintenance tasks are being done.
- **Keeps Conveyors Running Efficiently and Consistently**
 - Reduces unscheduled downtime.
 - Increases production uptime.
- **Saves Money**
 - Increases belt wear life.
 - Extends life of rollers, pulleys and splices.
 - High cost of accidents.



Types of Belt Cleaners

- **Primary Cleaners**
 - Mounted on the head pulley.
 - Mounted below the material flow.
 - Removes the big stuff. Typically cleans off up to 80% of the initial carryback.
- **Secondary Cleaners**
 - Located just past where the belt leaves the head pulley and anywhere down the beltline.
 - Special secondaries may allow for mounting under the head pulley.
 - Removes sticky fines – the final cleaning job.
 - May require a hold-down roller for maximum performance.
- **Specialty Cleaners**
 - Primary Cleaners or Secondaries designed especially for specific or extreme applications.

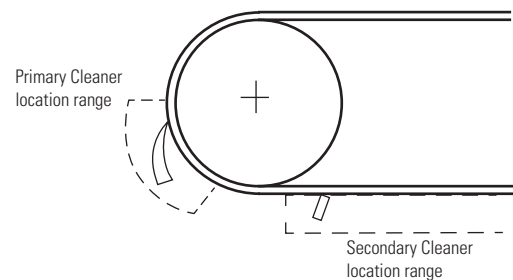

Definition of Terms

- **Carryback**—Material that sticks to the belt after it leaves the transfer point and continues falling off along the conveyor's return side.
- **Material Path**—The section of the belt where most of the material is conveyed. Typically the center 2/3 of the belt.
- **Hold-Down Roller**—A stabilising roller or pressure roller located on top of the return side of the belt to prevent belt flap or to provide a consistent flat surface for the blades on a lighter-tensioned belt.

Types of Cleaner Blades

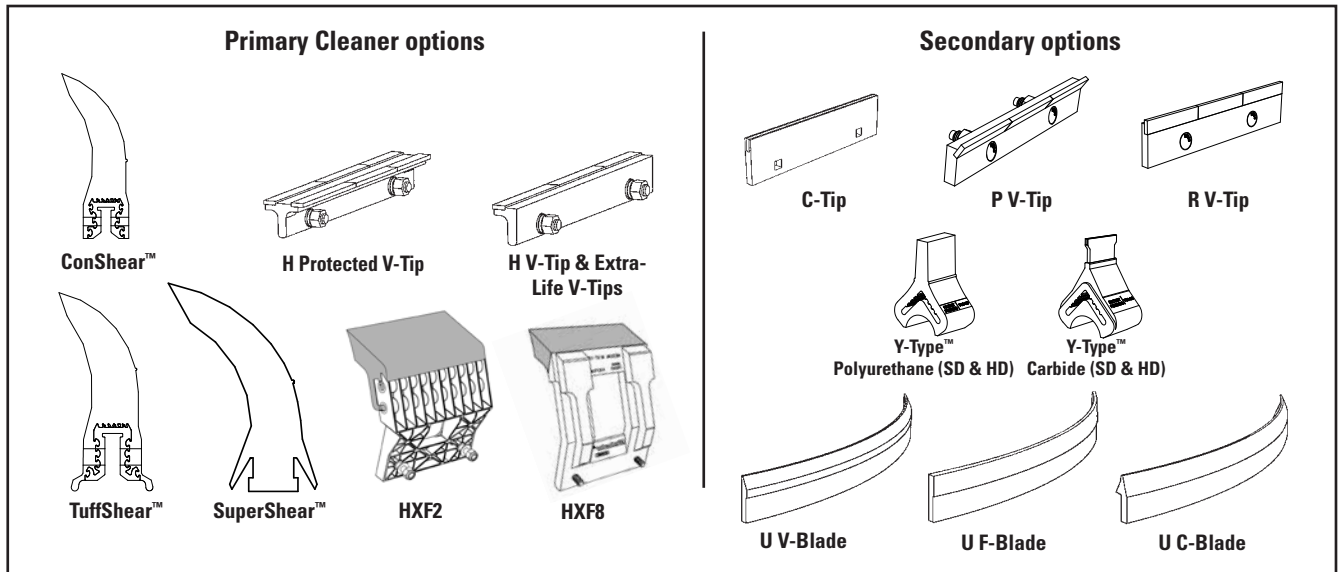

F-Tip/Blade - for mechanically fastened belts **V-Tip/Blade** - for vulcanised belts only **C-Tip/Blade** - for both

Polyurethane Blades

Not all polyurethanes are the same. Flexco's polyurethane blades are specially formulated for abrasion resistance and long wear. Independent testing has shown that Flexco's polyurethane blades last as much as 30% longer than other OEM blades.

- Easy on the belt.
- Work well with mechanical splices.
- Economical.
- Specialty formulations for high heat, chemical resistance, or water removal.
- FRAS for underground applications.



Less advanced polyurethane formulations result in blades that experience quicker wear and provide less-efficient cleaning.

Tungsten Carbide

Excellent for superior cleaning efficiency and long wear. The quality and application of carbides can vary. Flexco® has invested years of research and testing to develop tungsten carbide tips for both vulcanised and mechanically fastened belts. And a quality process ensures consistent results.

- Superior cleaning.
- Long wear.
- C-Tips/blades for mechanical splices and V-Tips/blades for vulcanised belts.

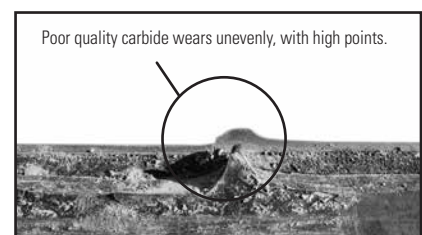

Blade Angle (Secondary cleaners)

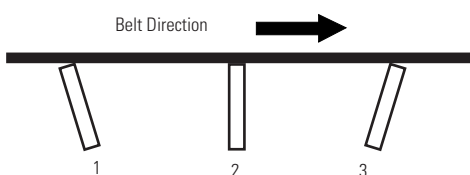

1. Aggressive - excellent cleanability, high risk for belt damage.
2. 90° to belt - good cleaning efficiency; must have good blade relief for splices (Flexco recommended).
3. Wiping - a little less cleaning power; safer on belts in poor condition or with poor mechanical splices.

Belt Cleaning Systems

Keys to Good Belt Cleaning

- Proper cleaner selection for the application
- Correct installation
- Regular service maintenance

Spec'ing and Ordering Belt Cleaners

Information needed:

- A.** Belt Width
- B.** Conveyor frame (structure) width
- C.** Head pulley diameter
- D.** For Primary Cleaners - what is the belt's material path
- E.** Material conveyed (dry, wet, sticky, etc.)
- F.** Type of belt splice:
 - Mechanical - skived or unskived
 - Vulcanised
- G.** Temperature or other extreme environmental factors
- H.** Does the belt reverse

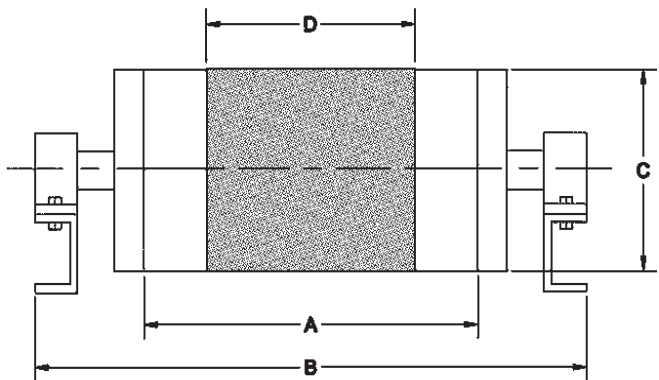

Primary Cleaner Selection Guide









Primary Cleaner Specification Chart

APPLICATION DESCRIPTION	EZP-LS	EZP1, HIGH TEMP EZP1	MMP	MHP	MHCP	H-TYPE® (HFX2, XF, XF8)	H-TYPE® (V)
Belt Width*	300 - 1500 mm	300 - 1800 mm	600 - 2100 mm	600 - 2400 mm	600 - 2100 mm	450 - 3200 mm	450 - 3200 mm
Head Pulley Diameter	150 - 550 mm	250 - 900 mm	400 - 1200 mm	500 - 1200 mm	500 - 1200 mm	250 - 1325 mm	250 - 1575 mm
Reversing Belts	Yes	Yes	Yes	Yes	Yes	Yes	Yes
Mechanical Fasteners	Yes	Yes	Yes	Yes	Yes	Yes	No



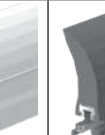

*Special sizes available upon request.

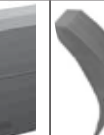
Contact Flexco® for pulleys over 1700 mm diameter.

Primary Cleaner Blade Specifications

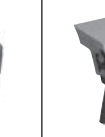
									
Blade Type	ConShear™ LS	ConShear™ LS High Temp	ConShear™ LS White (Chemical Resistant/Food Grade) ‡	ConShear™	ConShear™ High Temp	ConShear™ White (Chemical Resistant/Food Grade) ‡	TuffShear™	MegaShear™	SuperShear™
Temperature Range	-30 to 180°F (-35 to 82°C)	up to 275°F (135°C) with spikes to 325°F (163°C)	-30 to 180°F (-35 to 82°C)	-30 to 180°F (-35 to 82°C)	up to 275°F (135°C) with spikes to 325°F (163°C)	-30 to 180°F (-35 to 82°C)	-30 to 180°F (-35 to 82°C)	-30 to 180°F (-35 to 82°C)	-30 to 180°F (-35 to 82°C)
Polyurethane	Yes	Yes	Yes	Yes	Yes	Yes	Yes	Yes	Yes
Durometer	83	93	83	83	93	83	83	90	90
Tungsten Carbide	No	No	No	No	No	No	No	No	No
Work with Mechanical Fasteners	Yes	Yes	Yes	Yes	Yes	Yes	Yes	Yes	Yes
FRAS	Contact Flexco								

Primary Cleaner Blade Specifications (cont.)

					
BLADE TYPE	HXF	HXF2	H V-TIP	H PROTECTED V-TIP	Extra Life V-Tips
Temperature Range	-35 to 82°C	-35 to 82°C	-35 to 205°C	-35 to 205°C	-35 to 205°C
Polyurethane	Yes	Yes	No	No	No
Durometer	84	83	N/A	N/A	N/A
Tungsten Carbide	No	No	Yes	Yes	Yes
Work with Mechanical Fasteners	Yes	Yes	No	No	No
FRAS	Yes	No	N/A	N/A	N/A

For Belt Speed information please consult your Flexco® representative

Secondary Cleaner Selection Guide

Secondary Cleaner Specification Chart

APPLICATION DESCRIPTION	MHS (C-TIP)	MHS (V-TIP)	P-TYPE® (C-TIP)	P-TYPE (V-TIP)	P-TYPE-LS (C-TIP)	Y-Type SD Polyurethane	Y-Type SD Carbide	Y-Type HD Polyurethane	Y-Type HD Carbide
Belt Width*	600-3000mm	600-3000mm	450-3000mm	450-3000mm	450-3000mm	450-1200mm	450-1200mm	900-1800mm	900-1800mm
Secondary Cleaner Blade Options	Yes	Yes	No	No	No	Yes	Yes	Yes	Yes
Work with Mechanical Fasteners	Yes	No	Yes	No	Yes	Yes	Yes	Yes	Yes

*Special sizes available upon request.
Contact Flexco® for belt widths over 3000 mm diameter.

Secondary Cleaner Specification Chart (cont.)

APPLICATION DESCRIPTION	U-TYPE® (F-BLADE)	U-TYPE (C-BLADE)	U-TYPE (V-BLADE)	R-TYPE® (C-TIP)	R-TYPE (V-TIP)	CHEVRON	Brush Cleaner
Belt Width*	450-3000mm	450-3000mm	450-3000mm	450-3000 mm	450-3000 mm	450-1500mm	450-2100 mm
Secondary Cleaner Blade Options	No	No	No	Yes	Yes	Yes	Yes
Work with Mechanical Fasteners	Yes	Yes	No	Yes	No	Yes	Yes

*Special sizes available upon request.
Contact Flexco for belt widths over 3000 mm diameter.

Secondary Cleaner Blade Specifications

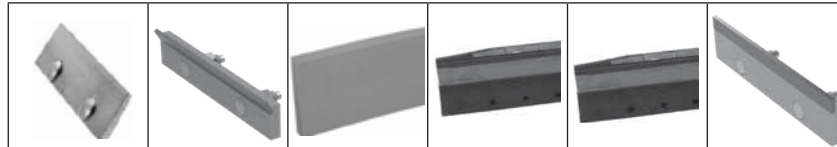

BLADE TYPE	C-TIP	P V-TIP	U F-BLADE	U C-BLADE	U V-BLADE	R V-TIP
Temperature Range	-35 to 205°C	-35 to 205°C	-35 to 82°C	-35 to 82°C	-35 to 82°C	-35 to 205°C
Polyurethane	No	No	Yes	Rubber	Rubber	No
Durometer	N/A	N/A	90	84	83	N/A
Tungsten Carbide	Yes	Yes	No	Yes	Yes	Yes
Work with Mechanical Fasteners	Yes	No	Yes	Yes	No	No

Secondary Cleaner Blade Specifications cont.

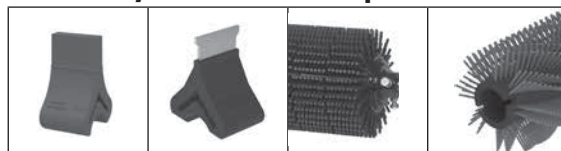

BLADE TYPE	Y-Type Polyurethane	Y-Type Carbide	Chevron	Brush Cleaner
Temperature Range	-35 to 82°C	-35 to 82°C	-35 to 82°C	-30 to 82°C
Polyurethane	Yes	No	Rubber	Polypropylene
Durometer	86A	N/A	N/A	N/A
Tungsten Carbide	YNo	Yes	No	No
Work with Mechanical Fasteners	Yes	Yes	Yes	Yes

For Belt Speed information please consult your Flexco® representative

Product Ordering Information

EZP-LS Limited Space Primary Cleaner and Stainless Steel Limited Space Primary Cleaner



EZP-LS Primary Cleaner Belt Width Minus 50mm

BELT WIDTH mm	BLADE COVERAGE mm	ORDERING NUMBER	ITEM CODE	WT. KG.
300	250	EZP-LS212	77127	11.3
450	400	EZP-LS218	77128	12.8
600	550	EZP-LS224	77129	14.4
750	700	EZP-LS230	77130	16.0
900	850	EZP-LS236	77131	17.6
1050	1000	EZP-LS242	77132	19.1
1200	1150	EZP-LS248	77133	20.7
1350	1300	EZP-LS254	77134	22.2
1500	1450	EZP-LS260	77135	23.9

EZP-LS High-Temp Primary Cleaner Belt Width Minus 2" (50mm)

BELT WIDTH		BLADE WIDTH		ORDERING NUMBER	ITEM CODE	WT. KG.
in.	mm	in.	mm			
12	300	10	250	EZP-LS212HT	77746	24.8
18	450	16	400	EZP-LS218HT	77747	28.2
24	600	22	550	EZP-LS224HT	77748	31.7
30	750	28	700	EZP-LS230HT	77749	35.1
36	900	34	850	EZP-LS236HT	77750	38.6
42	1050	40	1000	EZP-LS242HT	77751	42.0
48	1200	46	1150	EZP-LS248HT	77752	45.5
54	1350	52	1300	EZP-LS254HT	77753	48.9
60	1500	58	1450	EZP-LS260HT	77754	52.5

Stock items (non-shaded) refer to (*) for specific lead time, if not specified, standard lead time applies.

Non-stock items (shaded) please contact Flexco for dispatch options and lead times.

U.S. Patent No. D482,508S (blade)
Patent Pending (tensioner)

EZP-LS Stainless Steel Primary Cleaner Belt Width Minus 50mm (2")

BELT WIDTH mm	BLADE COVERAGE mm	ORDERING NUMBER	ITEM CODE	WT. KG.
300	250	EZP-LS212-S/S	62836	11.3
450	400	EZP-LS218-S/S	62837	12.8
600	550	EZP-LS224-S/S	62838	14.4
750	700	EZP-LS230-S/S	62839	16.0
900	850	EZP-LS236-S/S	62840	17.6
1050	1000	EZP-LS242-S/S	62841	19.1
1200	1150	EZP-LS248-S/S	62842	20.7
1350	1300	EZP-LS254-S/S	62843	22.2
1500	1450	EZP-LS260-S/S	62844	23.9

Lead time: 3 weeks

EZP-LS Stainless Steel High-Temp Primary Cleaner Belt Width Minus 50mm (2")

BELT WIDTH mm	BLADE COVERAGE mm	ORDERING NUMBER	ITEM CODE	WT. KG.
300	250	EZP-LS212HT-S/S	62845	11.3
450	400	EZP-LS218HT-S/S	62846	12.8
600	550	EZP-LS224HT-S/S	62847	14.4
750	700	EZP-LS230HT-S/S	62848	16.0
900	850	EZP-LS236HT-S/S	62849	17.6
1050	1000	EZP-LS242HT-S/S	62850	19.1
1200	1150	EZP-LS248HT-S/S	62851	20.7
1350	1300	EZP-LS254HT-S/S	62852	22.2
1500	1450	EZP-LS260HT-S/S	62853	23.9

Lead time: 3 weeks

EZP-LS Stainless Steel Primary Cleaner with White ConShear LS Blade Belt Width Minus 50mm (2")

BELT WIDTH mm	BLADE COVERAGE mm	ORDERING NUMBER	ITEM CODE	WT. KG.
300	250	CLSFG-212	77144	11.3
450	400	CLSFG-218	77145	12.8
600	550	CLSFG-224	77146	14.4
750	700	CLSFG-230	77147	16
900	850	CLSFG-236	77148	17.5
1050	1000	CLSFG-242	77149	19.1
1200	1150	CLSFG-248	77150	20.7
1350	1300	CLSFG-254	77151	22.2
1500	1450	CLSFG-260	77152	23.9

Specifications & Guidelines

EZP-LS Limited Space Primary Cleaner

Pole Length Specifications*

CLEANER SIZE mm	POLE LENGTH mm	MAXIMUM CONVEYOR SPAN mm
300	1050	925
450	1200	1075
600	1350	1225
750	1500	1375
900	1650	1525
1050	1800	1675
1200	1950	1825
1350	2200	2075
1500	2350	2225
1800	2650	2525

Pole Diameter - 48 mm

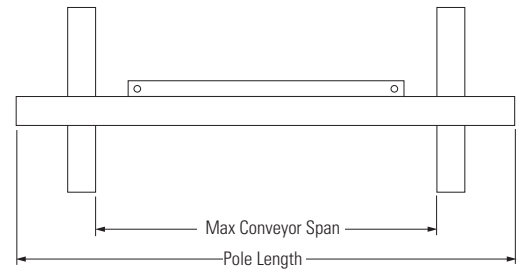

Clearance Guidelines for Installation

HORIZONTAL CLEARANCE REQUIRED mm	VERTICAL CLEARANCE REQUIRED mm
75	165

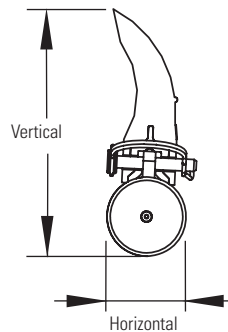

Pole Location Specs

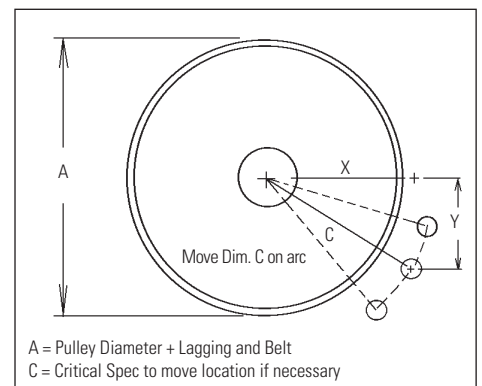

Spring Length Chart with LST Spring Tensioner

BLADE WIDTH mm	PURPLE SPRING mm	SILVER SPRING mm	BLACK SPRING mm
254	51	N/A	N/A
406	41	54	N/A
559	N/A	51	N/A
711	N/A	48	N/A
864	N/A	44	N/A
1016	N/A	38	N/A
1168	N/A	35	51
1321	N/A	N/A	51
1473	N/A	N/A	48

Shading indicates preferred spring option

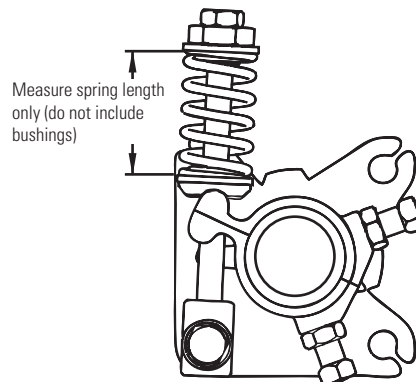

Pole Location Chart

A	X	Y	C
152	67	140	156
178	83	140	162
203	99	140	171
229	111	140	178
254	127	140	187
279	140	140	197
305	156	140	210
330	168	140	219
356	181	140	229
381	194	140	238
406	210	140	251
432	222	140	264
457	235	140	273
483	248	140	286
508	260	140	295
533	273	140	308
559	286	140	318

Specifications:

- Maximum Belt SpeedContact Flexco®
- Temperature Rating-35°C to 82°C
- Minimum Pulley Diameter.....150 mm
- Blade Height.....115 mm
- Usable Blade Wear Length.....60 mm
- BladePolyurethane (proprietary blend for abrasion resistance and long wear)
- Available for Belt Widths300 to 1800 mm

Replacement Parts List

EZP-LS Limited Space Primary Cleaner

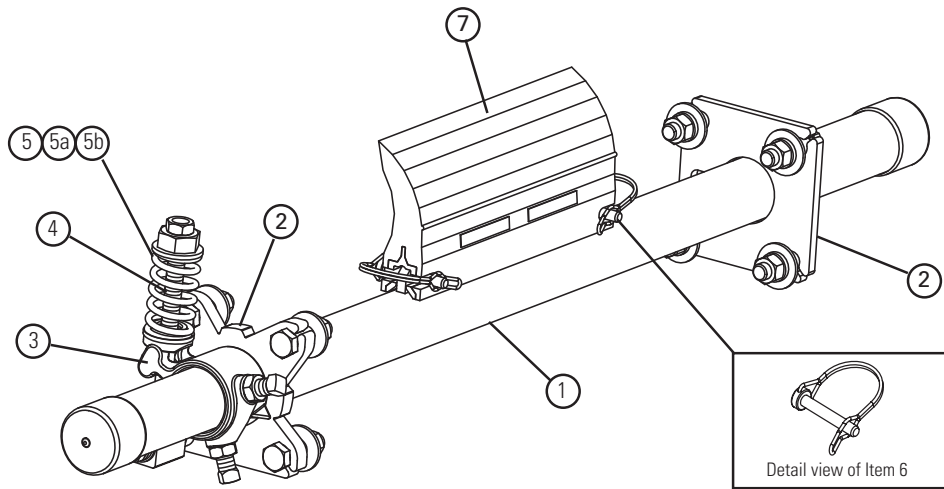

Replacement Parts

REF	DESCRIPTION	ORDERING NUMBER	ITEM CODE	WT. KG.
1	300 mm Pole	LSP12	77070	6.0
	450 mm Pole	LSP18	77071	7.0
	600 mm Pole	LSP24	77072	8.0
	750 mm Pole	LSP30	77073	9.0
	900 mm Pole	LSP36	77074	10.0
	1050 mm Pole	LSP42	77075	11.0
	1200 mm Pole	LSP48	77076	12.0
	1350 mm Pole	LSP54	77077	13.0
	1500 mm Pole	LSP60	77078	14.1
2	Mounting Plate Kit* (incl. 1 tensioner mounting plate and 1 pole mounting plate)	LSTMPK	77366	1.6
3	Torque Arm Kit* (1 ea.)	LST-TAK	77120	0.6
4	Pivot Block/Rod Kit* (1 ea.)	LSTPB-RK	77367	0.4
5	Tension Spring - Purple (1 ea.) for blades 250-400 mm	LS-SP	77365	0.1
5a	Tension Spring - White (1 ea.) for blades 550 - 1150 mm	LS-SW	77117	0.1
5b	Tension Spring - Silver (1 ea.) for blades 1300 - 1450 mm	LS-SS	77118	0.1
6	LS Blade Pin (1 ea.)	LS-BP	77114	0.0
-	LST Spring Tensioner* - Purple incl. 1 tensioner mounting plate and 1 ea. items 3, 4 & 5 for blades 250-400 mm	LST-P	77121	3.4
-	LST Spring Tensioner* - White incl. 1 tensioner mounting plate and 1 ea. items 3, 4 & 5a for blades 550 - 1150 mm	LST-W	77122	3.5
-	LST Spring Tensioner* - Silver incl. 1 tensioner mounting plate and 1 ea. items 3, 4 & 5b for blades 1300 - 1450 mm	LST-S	77123	3.5

Hardware Included

Spring Tensioner Selection Chart

CLEANER BLADE WIDTH	77121 PURPLE	77122 WHITE	77123 SILVER
ConShear-LS 250 - 400 mm	X		
ConShear-LS 550 - 1150 mm		X	
ConShear-LS 1300 - 1450 mm			X

U.S. Patent No. D482,508S (blade)
Patent Pending (tensioner)

For best results use Flexco® Genuine Replacement Blades and Parts.

Replacement Parts List

EZP-LS Stainless Steel Limited Space Primary Cleaner

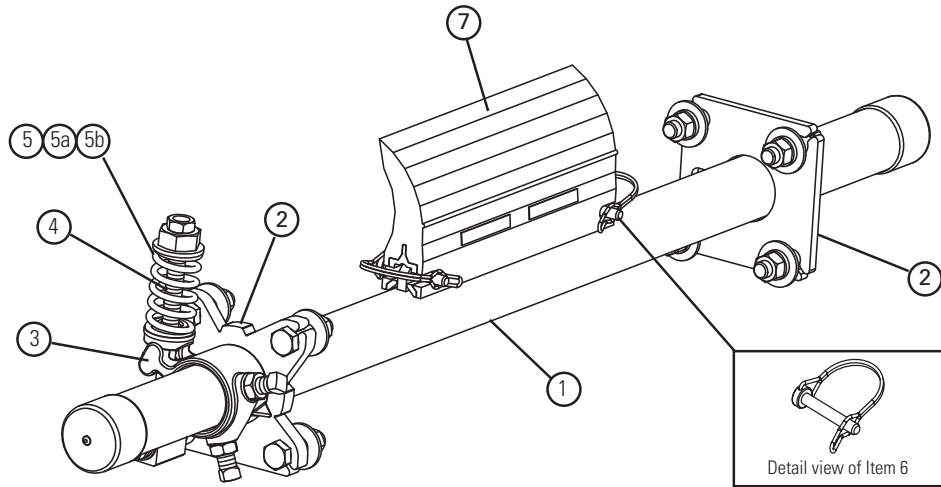

Replacement Parts

REF	DESCRIPTION	ORDERING NUMBER	ITEM CODE	WT. KG.
1	300 mm SS Pole	LSP12-S/S	77079	6
	450 mm SS Pole	LSP18-S/S	77080	7
	600 mm SS Pole	LSP24-S/S	77081	8
	750 mm SS Pole	LSP30-S/S	77082	9
	900 mm SS Pole	LSP36-S/S	77083	10
	1050 mm SS Pole	LSP42-S/S	77084	11
	1200 mm SS Pole	LSP48-S/S	77085	12
	1350 mm SS Pole	LSP54-S/S	77086	13
	1500 mm SS Pole	LSP60-S/S	77087	14.1
2	SS Mounting Plate Kit (10"-46"/250-1150mm)* (incl. 1 tensioner mounting plate and 1 pole mounting plate)	LSTMPK-S/S	78933	1.6
2a	SS Mounting Plate Kit (52"+/1300mm+)* (incl. 2 tensioner mounting plates)	LSTMPK2-S/S	78462	3.3
3	Torque Arm Kit* (1 ea.)	LST-TAK	77120	0.6
4	Pivot Block/Rod Kit* (1 ea.)	LSTPB-RK	77367	0.4
5	Tension Spring - Black (1 ea.) for blades 10'-28" (250-700mm)	CTS-B-S/S	78387	0.1
5a	Tension Spring - White (1 ea.) for blades 34" - 70" (850 - 1750mm)	LS-SW-S/S	78850	0.1
5b	Tension Spring - Silver (1 ea.) for blades 1300 - 1450 mm)	LS-SS	77118	0.1
6	SS LS Blade Pin (1 ea.)	LS-BP-S/S	77115	0
-	SS LST Spring Tensioner* - Black incl. 1 ea. items 2 & 3 for blades 10'-28" (250 - 700mm)	LST-B-S/S	77124	3.4
-	SS LST Spring Tensioner* - White incl. 1 ea. items 2 & 3a for blades 34"- 46" (850 - 1150mm)	LST-W-S/S	77125	3.5
-	SS LST Spring Tensioner* - White (dual) incl. 1 ea. item 2a and 2 ea. item 3a for blades 52"- 70" (1300 - 1750mm)	LST-W-S/S-2	77126	6.9

Hardware Included

 **Stock items** (non-shaded) refer to (*) for specific lead time, if not specified, standard lead time applies.

 **Non-stock items** (shaded) please contact Flexco for dispatch options and lead times.

U.S. Patent No. D482,508S (blade)
Patent Pending (tensioner)

For best results use Flexco® Genuine Replacement Blades and Parts.

Spring Tensioner Selection Chart

CLEANER BLADE WIDTH	77124 BLACK	77125 WHITE	77126 WHITE (Dual)
ConShear-LS 250 - 700 mm	X		
ConShear-LS 850 - 1150 mm		X	
ConShear-LS 1300 - 1750 mm			X

Replacement Parts List

EZP-LS *Limited Space Primary Cleaner and Stainless Steel Limited Space Primary Cleaner*

Ordering Information ConShear™-LS Replacement Blades

BELT WIDTH mm	BLADE WIDTH mm	ORDERING NUMBER	ITEM CODE	WT. KG.
300	250	CRB-LS10	77088	1.0
450	400	CRB-LS16	77089	1.5
600	550	CRB-LS22	77090	2.1
750	700	CRB-LS28	77091	2.6
900	850	CRB-LS34	77092	3.2
1050	1000	CRB-LS40	77093	3.8
1200	1150	CRB-LS46	77094	4.4
1350	1300	CRB-LS52	77095	4.9
1500	1450	CRB-LS58	77096	5.5

Other blade sizes available upon request.

Ordering Information ConShear™-LS High-Temp Replacement Blades

BLADE WIDTH mm	ORDERING NUMBER	ITEM CODE	WT. LBS.
400	CRB-LS16HT	77552	1.5
550	CRB-LS22HT	77553	2.1
700	CRB-LS28HT	77554	2.6
850	CRB-LS34HT	77555	3.2
1000	CRB-LS40HT	77556	3.8
1150	CRB-LS46HT	77557	4.4
1300	CRB-LS52HT	77558	4.9
1450	CRB-LS58HT	77559	5.5

Other blade sizes available upon request.

Ordering Information White ConShear™-LS Replacement Blades (Chemical Resistant/Food Grade) ‡

BLADE WIDTH mm	ORDERING NUMBER	ITEM CODE	WT. KG.
250	CRB-LS10W	77097	1.0
400	CRB-LS16W	77098	1.5
550	CRB-LS22W	77099	2.1
700	CRB-LS28W	77100	2.6
850	CRB-LS34W	77101	3.2
1000	CRB-LS40W	77102	3.8
1150	CRB-LS46W	77103	4.4
1300	CRB-LS52W	77104	4.9
1450	CRB-LS58W	77105	5.5

‡ All ingredients used in the urethane formulation of this blade comply with the relevant requirements of 21 CFR (FDA Code of Federal Regulations) for use in repeated bulk dry food applications

Stock items (non-shaded) refer to (*) for specific lead time, if not specified, standard lead time applies.

Non-stock items (shaded) please contact Flexco for dispatch options and lead times.

Product Ordering Information

EZP1 Standard Duty Primary Cleaner and EZP1 Stainless Steel Primary Cleaner



Ordering Information EZP1 Primary Cleaner Belt Width Minus 50mm

BELT WIDTH mm	BLADE COVERAGE mm	ORDERING NUMBER	ITEM CODE	WT. KG.
450	400	EZP1-218	75611	25.1
600	550	EZP1-224	75612	27.8
750	700	EZP1-230	75613	30.5
900	850	EZP1-236	75614	33.2
1050	1000	EZP1-242	75615	35.9
1200	1150	EZP1-248	75616	38.6
1350	1300	EZP1-254	75617	41.2
1500	1450	EZP1-260	75618	43.9
1800	1750	EZP1-272	75771	46.6

Ordering Information EZP1 High Temp Primary Cleaner Belt Width Minus 50mm

BELT WIDTH mm	BLADE COVERAGE mm	ORDERING NUMBER	ITEM CODE	WT. KG.
300	250	HTF212	76658	22
450	400	HTF218	76659	25.1
600	550	HTF224	76660	27.8
750	700	HTF230	76661	30.5
900	850	HTF236	76662	33.2
1050	1000	HTF242	76663	35.9
1200	1150	HTF248	76664	38.6
1350	1300	HTF254	76665	41.2
1500	1450	HTF260	76666	43.9
1800	1750	HTF272	76667	46.6

Ordering Information EZP1 Primary Cleaner Stainless Steel

BELT WIDTH mm	BLADE COVERAGE mm	ORDERING NUMBER	ITEM CODE	WT. KG.
450	400	EZP1-218-S/S	61081	25.7
600	550	EZP1-224-S/S	61082	28.4
750	700	EZP1-230-S/S	61017	31.1
900	850	EZP1-236-S/S	61083	33.9
1050	1000	EZP1-242-S/S	61016	36.6
1200	1150	EZP1-248-S/S	61084	39.3
1350	1300	EZP1-254-S/S	61085	42
1500	1450	EZP1-260-S/S	61086	44.8
1800	1750	EZP1-272-S/S	61087	47.5

Other blade sizes available upon request.

Ordering Information EZP1 Primary Cleaner Stainless Steel High Temp Belt Width Minus 50mm

BELT WIDTH mm	BLADE COVERAGE mm	ORDERING NUMBER	ITEM CODE	WT. KG.
300	250	HTF212-S/S	62826	22.0
450	400	HTF218-S/S	62827	25.1
600	550	HTF224-S/S	62828	27.8
750	700	HTF230-S/S	62829	30.5
900	850	HTF236-S/S	62830	33.2
1050	1000	HTF242-S/S	62831	35.9
1200	1150	HTF248-S/S	62832	38.6
1350	1300	HTF254-S/S	62833	41.2
1500	1450	HTF260-S/S	62834	43.9
1800	1750	HTF272-S/S	62835	46.6

Ordering Information EZP1 Stainless Steel Primary Cleaner with White ConShear Blade Belt Width Minus 50mm

BELT WIDTH mm	BLADE COVERAGE mm	ORDERING NUMBER	ITEM CODE	WT. KG.
300	250	CFG-212	78838	22.5
450	400	CFG-218	78839	25.1
600	550	CFG-224	78840	27.8
750	700	CFG-230	78841	30.5
900	850	CFG-236	78842	33.2
1050	1000	CFG-242	78843	35.9
1200	1150	CFG-248	78844	38.5
1350	1300	CFG-254	78845	41.2
1500	1450	CFG-260	78846	43.9
1800	1750	CFG-272	78847	46.6

Stock items (non-shaded) refer to (*) for specific lead time, if not specified, standard lead time applies.

Non-stock items (shaded) please contact Flexco for dispatch options and lead times.

U.S. Patent No. D482,508S

Specifications & Guidelines

EZP1 Standard Duty Primary Cleaner

Pole Length Specifications*

CLEANER SIZE mm	POLE LENGTH mm	MAXIMUM CONVEYOR SPAN mm
300	1050	925
450	1200	1075
600	1350	1225
750	1500	1375
900	1650	1525
1050	1800	1675
1200	1950	1825
1350	2200	2075
1500	2350	2225
1800	2650	2525

Pole Diameter - 60mm

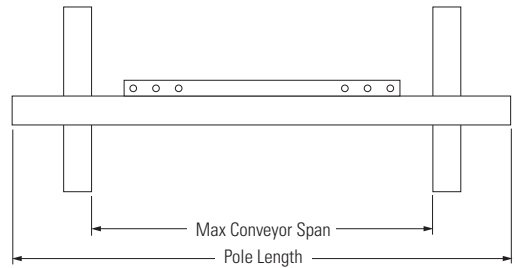

Clearance Guidelines for Installation

HORIZONTAL CLEARANCE REQUIRED mm	VERTICAL CLEARANCE REQUIRED mm
100	238

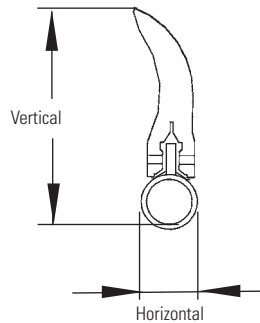

Spring Length Chart with EST Spring Tensioner

BLADE WIDTH mm	PURPLE SPRING mm	SILVER SPRING mm	BLACK SPRING mm
254	146	159	N/A
406	133	152	N/A
559	121	149	N/A
711	108	143	N/A
864	N/A	137	143
1016	N/A	130	140
1168	N/A	127	133
1321	N/A	121	130
1473	N/A	N/A	127
1626	N/A	N/A	121
1778	N/A	N/A	118

Shading indicates preferred spring option

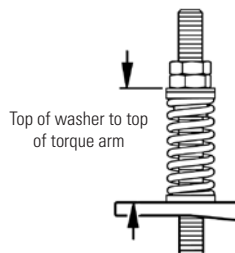

Specifications:

- Maximum Belt SpeedContact Flexco®
- Temperature Rating-35°C to 82°C
- Minimum Pulley Diameter.....250mm
- Usable Blade Wear Length.....100mm
- BladePolyurethane (proprietary blend for abrasion resistance and long wear)
- Available for Belt Widths300 to 1800 mm

U.S. Patent No. D482,508S

Pole Location Specs

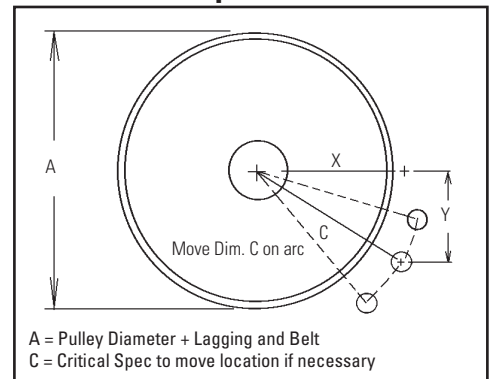

A = Pulley Diameter + Lagging and Belt
C = Critical Spec to move location if necessary

Pole Location Chart

A	X	Y	C
254	76	229	241
279	95	229	248
305	111	229	254
330	137	229	267
356	149	229	273
381	171	229	286
406	181	229	292
432	200	229	305
457	210	229	311
483	229	229	324
508	238	229	330
533	254	229	343
559	273	229	356
584	289	229	368
610	305	229	381
635	321	229	394
660	337	229	406
686	353	229	419
711	365	229	432
737	381	229	445
762	397	229	457
787	410	229	470
813	425	229	483
838	438	229	495
864	454	229	508
889	467	229	521
914	483	229	533

Replacement Parts List

EZP1 Standard Duty Primary Cleaner

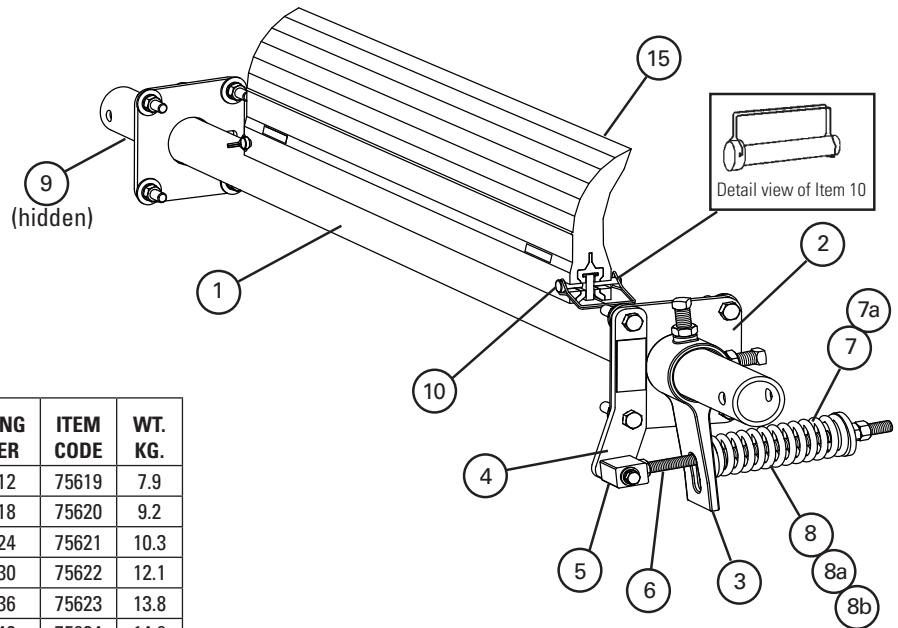

Replacement Parts

REF	DESCRIPTION	ORDERING NUMBER	ITEM CODE	WT. KG.
1	300 mm Pole	EZP1P12	75619	7.9
	450 mm Pole	EZP1P18	75620	9.2
	600 mm Pole	EZP1P24	75621	10.3
	750 mm Pole	EZP1P30	75622	12.1
	900 mm Pole	EZP1P36	75623	13.8
	1050 mm Pole	EZP1P42	75624	14.9
	1200 mm Pole	EZP1P48	75625	16.1
	1350 mm Pole	EZP1P54	75626	17.8
	1500 mm Pole	EZP1P60	75627	19.7
	1800 mm Pole	EZP1P72	75772	21.9
2	Mounting Plate Kit* (2 ea.)	EZP1MPK	75637	3.5
3	Torque Arm Kit* (1 ea.)	ESTAK	76406	1.6
4	Pivot Shaft Bracket Kit* (1 ea.)	ESPSBK	76407	0.8
5	Pivot Block Kit*	ESPBK	76408	0.3
6	Pivot Rod Kit*	ESPRK	76409	0.6
7	Bushing Kit - Purple and Silver (includes 2 bushings)	ESBK-PS	76410	0.1
7a	Bushing Kit - Black (includes 2 bushings)	ESBK-B	76411	0.1
8	Tension Spring - Purple	QMTS-P	75845	0.5
8a	Tension Spring - Silver	ESS-S	76412	0.6
8b	Tension Spring - Black	ESS-B	76413	0.6
9	Pole Lock* (1 ea.)	EZP1PL	75641	0.5
-	EST Tensioner - Purple* for blade widths 300 - 700 mm (includes 1 each items 3, 4, 5, 6, 7 & 8)	EST-P	76403	3.5
-	EST Tensioner - Silver* for blade widths 850 - 1300 mm (includes 1 each items 3, 4, 5, 6, 7 & 8a)	EST-S	76404	3.6
-	EST Tensioner - Black* for blade widths 1450 - 1750 mm (includes 1 each items 3, 4, 5, 6, 7a & 8b)	EST-B	76405	3.7
10	Blade Pin (1 ea.)	EZP1BP	75642	0.1

*Hardware Included

Spring Tensioner Selection Chart

CLEANER BLADE WIDTH	76403 EST-P	76404 EST-S	76405 EST-B
ConShear™ 300 - 700 mm	X		
ConShear 850 - 1300 mm		X	
ConShear 1450 - 1750 mm			X

Stock items (non-shaded) refer to (*) for specific lead time, if not specified, standard lead time applies.

Non-stock items (shaded) please contact Flexco for dispatch options and lead times.

U.S. Patent No. D482,508S

Replacement Parts List

EZP1 Stainless Steel Primary Cleaner

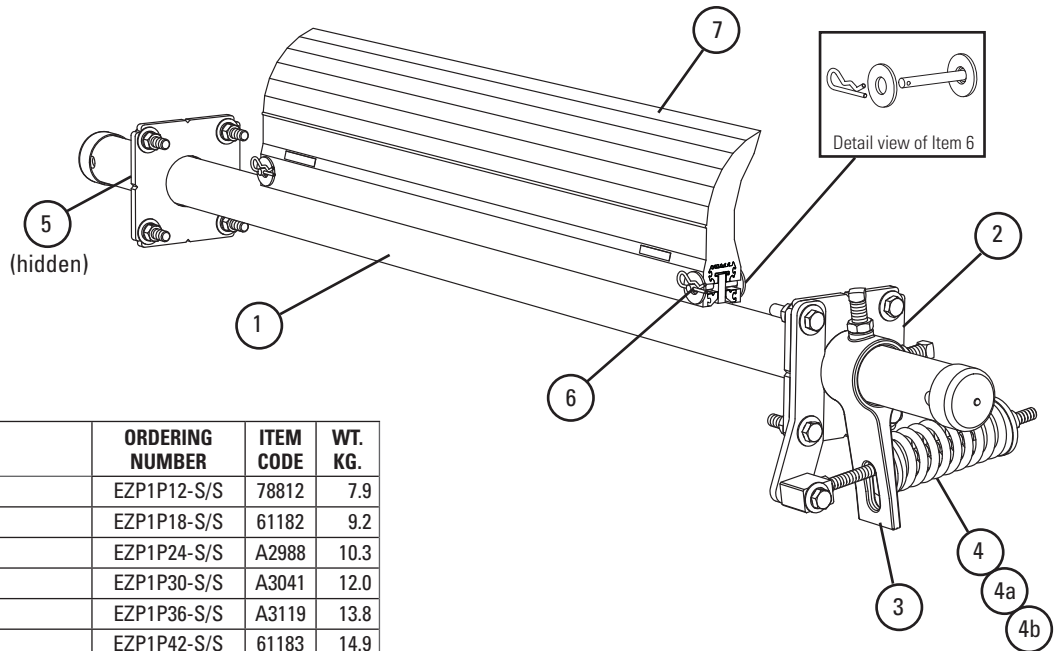

Replacement Parts

REF	DESCRIPTION	ORDERING NUMBER	ITEM CODE	WT. KG.
1	300 mm S/S Pole	EZP1P12-S/S	78812	7.9
	450 mm S/S Pole	EZP1P18-S/S	61182	9.2
	600 mm S/S Pole	EZP1P24-S/S	A2988	10.3
	750 mm S/S Pole	EZP1P30-S/S	A3041	12.0
	900 mm S/S Pole	EZP1P36-S/S	A3119	13.8
	1050 mm S/S Pole	EZP1P42-S/S	61183	14.9
	1200 mm S/S Pole	EZP1P48-S/S	61491	16.0
	1350 mm S/S Pole	EZP1P54-S/S	61184	17.8
	1500 mm S/S Pole	EZP1P60-S/S	61185	19.7
1800 mm S/S Pole	EZP1P72-S/S	61186	21.9	
2	SS Mounting Plate Kit* (2 ea.)	EZP1MPK-S/S	78923	3.5
3	SS Torque Arm Kit* (1 ea.)	ESTAK-EST-S/S	78849	1.6
4	SS Tension Spring - Purple	QMTS-P-S/S	77450	0.5
4a	SS Tension Spring - White	QMTS-W-S/S	77451	0.5
4b	SS Tension Spring - Gold	QMTS-G-S/S	77452	0.6
5	SS Pole Lock* (1 ea.)	EZP1PL-S/S	78848	0.5
-	SS EST Tensioner - Purple* for blade widths 12" - 28" (300 - 700mm) (includes 1 each items 2, 3, 4)	EST-P-S/S	78808	3.5
-	SS EST Tensioner - White* for blade widths 34" - 52" (850 - 1300mm) (includes 1 each items 2, 3, 4a)	EST-W-S/S	78809	3.6
-	SS EST Tensioner - Gold* for blade widths 58" - 70" (1450 - 1750mm) (includes 1 each items 2, 3, 4b)	EST-G-S/S	78810	3.7
6	Blade Pin (1 ea.)	MSPBPK-S/S	77583	0.0

*Hardware Included

Stainless Steel Spring Tensioner Selection Chart

CLEANER BLADE WIDTH	78808 EST-P-S/S	78809 EST-W-S/S	78810 EST-G-S/S
ConShear™ 300 - 700 mm	X		
ConShear 850 - 1300 mm		X	
ConShear 1450 - 1750 mm			X

Stock items (non-shaded) refer to (*) for specific lead time, if not specified, standard lead time applies.

Non-stock items (shaded) please contact Flexco for dispatch options and lead times.

Replacement Parts List

EZP1 Standard Duty Primary Cleaner and EZP1 Stainless Steel Primary Cleaner

Ordering Information ConShear™ Replacement Blades

BELT WIDTH mm	BLADE COVERAGE mm	ORDERING NUMBER	ITEM CODE	WT. KG.
450	400	CRB16	75629	3.3
600	550	CRB22	75630	4.6
750	700	CRB28	75631	5.8
900	850	CRB34	75632	7.1
1050	1000	CRB40	75633	8.0
1200	1150	CRB46	75634	9.6
1350	1300	CRB52	75635	10.8
1500	1450	CRB58	75636	12.1
1650	1600	CRB64	75775	13.3
1800	1750	CRB70	75773	14.6

Other blade sizes available upon request.

Ordering Information ConShear High Temp Replacement Blades

BELT WIDTH mm	BLADE COVERAGE mm	ORDERING NUMBER	ITEM CODE	WT. KG.
300	250	CRB-HT10	76593	2.2
450	400	CRB-HT16	76594	3.5
600	550	CRB-HT22	76595	4.7
750	700	CRB-HT28	76596	6
900	850	CRB-HT34	76597	7.4
1050	1000	CRB-HT40	76598	8.7
1200	1150	CRB-HT46	76599	13
1350	1300	CRB-HT52	76600	11.3
1500	1450	CRB-HT58	76601	12.6
1650	1600	CRB-HT64	76602	13.9
1800	1750	CRB-HT70	76603	15.2

Ordering Information White ConShear™ Replacement Blades (Chemical Resistant/Food Grade) ‡

BELT WIDTH mm	BLADE COVERAGE mm	ORDERING NUMBER	ITEM CODE	WT. KG.
450	400	CRB-W16	78472	3.3
600	550	CRB-W22	78473	4.6
750	700	CRB-W28	78474	5.8
900	850	CRB-W34	78475	7.1
1050	1000	CRB-W40	78476	8.0
1200	1150	CRB-W46	78477	9.6
1350	1300	CRB-W52	78478	10.8
1500	1450	CRB-W58	78479	12.1
1650	1600	CRB-W64	78480	13.3
1800	1750	CRB-W70	78481	14.6

‡ All ingredients used in the urethane formulation of this blade comply with the relevant requirements of 21 CFR (FDA Code of Federal Regulations) for use in repeated bulk dry food applications

Stock items (non-shaded) refer to (*) for specific lead time, if not specified, standard lead time applies.

Non-stock items (shaded) please contact Flexco for dispatch options and lead times.

Product Ordering Information

EZP1T Twist Tensioner Primary Cleaner

EZP1T Primary Cleaner with Twist Tensioner Belt Width Minus 2" (50mm)



BELT WIDTH		BLADE WIDTH		ORDERING NUMBER	ITEM CODE	WT. KG.
in.	mm	in.	mm			
12	300	10	250	EZP1T-212	78488	38.5
18	450	16	400	EZP1T-218	78489	44.5
24	600	22	550	EZP1T-224	78490	50.5
30	750	28	700	EZP1T-230	78491	56.5
36	900	34	850	EZP1T-236	78492	62.5
42	1050	40	1000	EZP1T-242	78493	68.4
48	1200	46	1150	EZP1T-248	78494	74.4
54	1350	52	1300	EZP1T-254	78495	83.7
60	1500	58	1450	EZP1T-260	78496	92.0
72	1800	70	1750	EZP1T-272	78497	101.6

Product Notes:

- For optimal cleaning and reduced blade retensioning maintenance, the cleaner blade width should be sized to fit the material path of the belt. The material path is typically 2/3 of the belt width. In most cases a blade size of belt width minus 200mm may be the best selection.
- Each cleaner can be retrofitted with three replacement blade sizes (belt width minus 50mm, minus 200mm, or minus 350mm).
- Comes complete with universal mounting plates and tensioner.
- Visual tension check. No guesswork on blade tensioning. Simply measure the spring, check label on tensioner and turn adjusting nut to restore optimal tension.
- Works with mechanical splices. Polyurethane blade glides over splices.
- Compatible with reversing belts.
- For applications requiring longer pole lengths, go to the minus 200mm chart and select the cleaner one belt width size larger. This will provide a pole 150mm longer and a blade size of belt width minus 50mm.

U.S. Patent No. D482,508S

Stock items (non-shaded) refer to (*) for specific lead time, if not specified, standard lead time applies.

Non-stock items (shaded) please contact Flexco for dispatch options and lead times.

Replacement Parts List

EZP1T Twist Tensioner Primary Cleaner

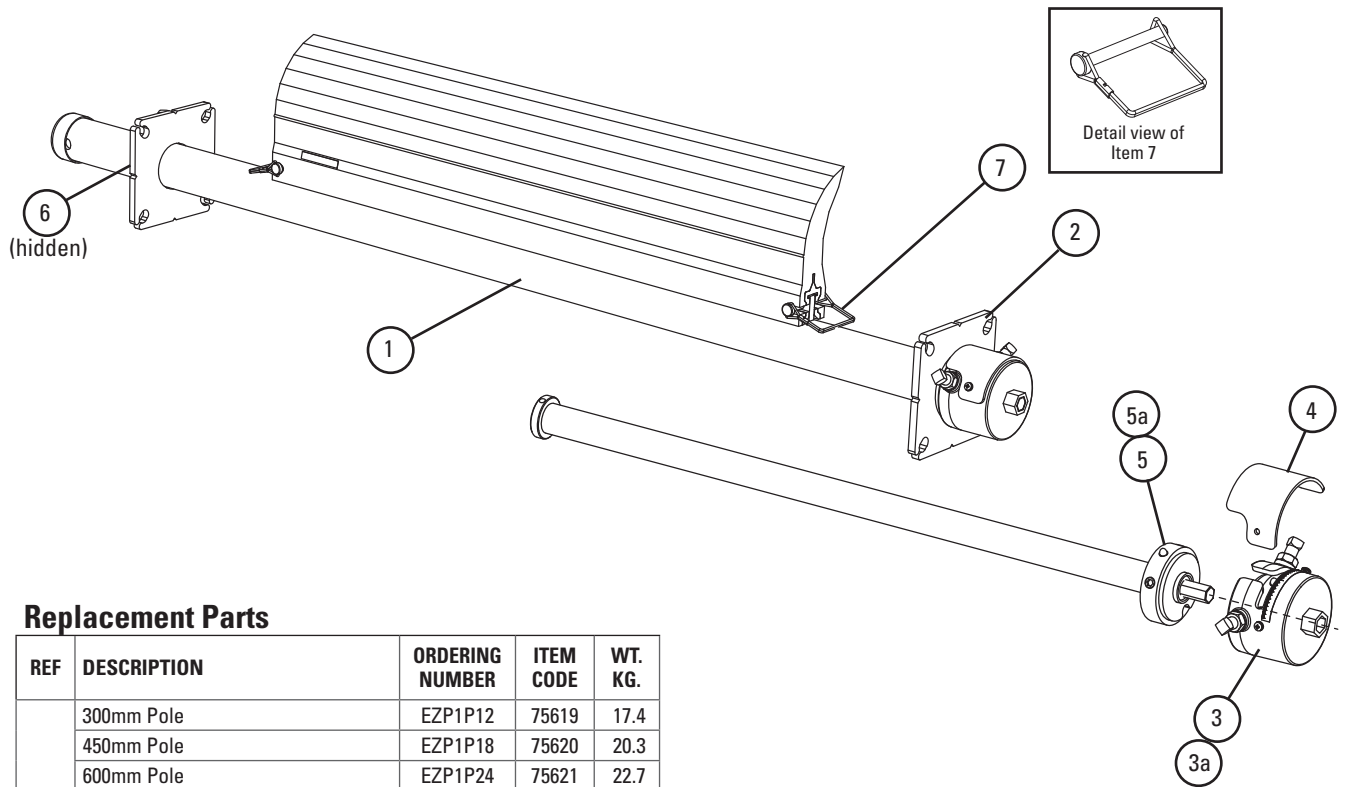

Replacement Parts

REF	DESCRIPTION	ORDERING NUMBER	ITEM CODE	WT. KG.
1	300mm Pole	EZP1P12	75619	17.4
	450mm Pole	EZP1P18	75620	20.3
	600mm Pole	EZP1P24	75621	22.7
	750mm Pole	EZP1P30	75622	26.5
	900mm Pole	EZP1P36	75623	30.4
	1050mm Pole	EZP1P42	75624	32.7
	1200mm Pole	EZP1P48	75625	35.3
	1350mm Pole	EZP1P54	75626	39.2
	1500mm Pole	EZP1P60	75627	43.3
	1800mm Pole	EZP1P72	75772	48.2
2	Torsion Mounting Plate Kit* (2 ea.)	EZPTMPK	78507	8.7
3	Torsion Cap Kit* (1 ea.) (includes 1 ea. Item 4)	EZPTCK	78508	3.2
3a	Torsion Cap Kit HD* (1 ea.) (includes 1 ea. Item 4)	EZPTCKHD	78509	3.2
4	Torsion Shield	EZPTSR	78510	.1
5	Torsion Spring Kit	EZPTSK	78511	6.0
5a	Torsion Spring Kit HD	EZPTSKHD	78512	8.5
6	Pole Lock* (1 ea.)	EZP1PL	75641	1.1
-	Torsion Bar Tensioner for blade widths 300 - 1200mm (includes 1 each items 3, 4, & 5)	EZPTBT	77384	17.4
-	Torsion Bar Tensioner HD for blade widths 1350 - 1800mm (includes 1 each items 3a, 4, & 5a)	EZPTBTHD	77385	20.0
7	Blade Pin (1 ea.)	EZP1BP	75642	0.1

*Hardware Included

Torsion Bar Tensioner Selection Chart

CLEANER BLADE WIDTH	77384 EZPTBT	77385 EZPTBTHD
ConShear 300 - 1200mm	X	
ConShear 1350 - 1800mm		X

U.S. Patent No. D482,508S

Stock items (non-shaded) refer to (*) for specific lead time, if not specified, standard lead time applies.

Non-stock items (shaded) please contact Flexco for dispatch options and lead times.

Product Ordering Information

Spring Covers and Tensioner Lock

Spring Covers

ORDERING NUMBER	ITEM CODE	WT. KG.
SPG-CVR-A	77387	0.14
SPG-CVR-B	77388	0.14
SPG-CVR-C	77389	0.14
SPG-CVR-D	77390	0.18
SPG-CVR-E	77391	0.18
SPG-CVR-F	77392	0.14
SPG-CVR-G	77393	0.14
SPG-CVR-H	77741	0.14

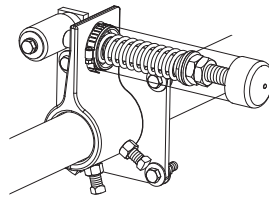
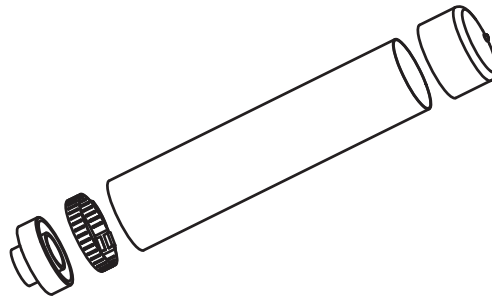

Spring cover on Primary Cleaner tensioner

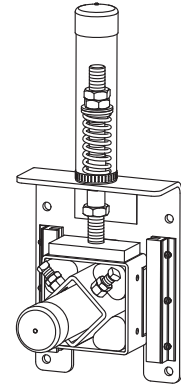

Spring cover on Secondary cleaner tensioner

Tensioner Lock

Designed to prevent tampering or unauthorized retensioning of the cleaner.

ORDERING NUMBER	ITEM CODE	WT. KG.
TEN-LOCK-KIT	77443	0.18

*For MSP, MMP, MHP, MHCP, H-Type® Primary Cleaner and MSS, MHS, MDWS Secondary Cleaners

Includes 1 tensioner lock
Lead time: 1 working day

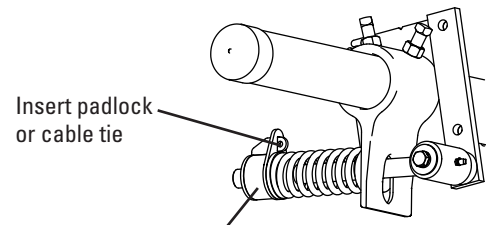
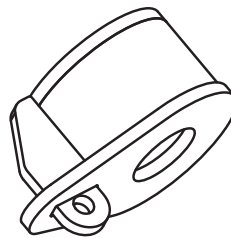

Tensioner Lock

(Primary Cleaner tensioner shown)

Patent pending

 **Stock items** (non-shaded) refer to (*) for specific lead time, if not specified, standard lead time applies.

 **Non-stock items** (shaded) please contact Flexco for dispatch options and lead times.

Product Ordering Information

MMP Medium Mine-Duty Primary Cleaner

MMP Medium-Duty Primary Cleaner Belt Width Minus 150mm Blade

BELT WIDTH mm	BLADE COVERAGE mm	ORDERING NUMBER	ITEM CODE	WT. KG.
600	450	MMP-624	76450	72.4
750	600	MMP-630	76451	79.6
900	750	MMP-636	76452	86.6
1050	900	MMP-642	76453	93.7
1200	1050	MMP-648	76454	100.8
1350	1200	MMP-654	76455	107.9
1500	1350	MMP-660	76456	115.0
1800	1650	MMP-672	76457	132.3
2100	1950	MMP-684	76798	156.4



Blade Width Selection

BELT WIDTH mm	ITEM CODE		
	BELT WIDTH MINUS 150 mm	BELT WIDTH MINUS 300 mm	BELT WIDTH MINUS 450 mm
600	76485	N/A	N/A
750	76486	76485	N/A
900	76487	76486	76485
1050	76488	76487	76486
1200	76489	76488	76487
1350	76490	76489	76488
1500	76491	76490	76489
1800	76493	76492	76491
2100	76697	76494	76493
2400	77048	77047	76697



TuffShear™
Replacement Blades

Ordering Information TuffShear™ Replacement Blades

BLADE WIDTH mm	ORDERING NUMBER	ITEM CODE	WT. KG.
450	TRB18	76485	9.6
600	TRB24	76486	12.7
750	TRB30	76487	15.9
900	TRB36	76488	19.1
1050	TRB42	76489	22.3
1200	TRB48	76490	25.5
1350	TRB54	76491	28.6
1500	TRB60	76492	31.8
1650	TRB66	76493	35.0
1800	TRB72	76494	38.2
1950	TRB78	76697	41.4

Other blade sizes available upon request.

Product Notes:

- Recommended for medium-duty conveyor applications. For abusive applications see the MHP Heavy-Duty Primary Cleaner or the MHCP Heavy-Duty Cartridge Primary Cleaner.
- Pole Length: Belt width plus 1350 mm. For longer requirements see Installation Accessories - Pole Extender Kit.
- Visual Tension Check: No guesswork on blade tensioning. Measure the spring and adjust to specified length per blade width to restore optimal tensioning.

Stock items (non-shaded) refer to (*) for specific lead time, if not specified, standard lead time applies.

Non-stock items (shaded) please contact Flexco for dispatch options and lead times.

Product Ordering Information

Stainless Steel MMP Medium Mine-Duty Primary Cleaner

Stainless Steel MMP Medium-Duty Primary Cleaner Belt Width Minus 150mm Blade

BELT WIDTH mm	BLADE WIDTH mm	ORDERING NUMBER	ITEM CODE
600	450	MMP-624-S/S	77424
750	600	MMP-630-S/S	77425
900	750	MMP-636-S/S	77426
1050	900	MMP-642-S/S	77427
1200	1050	MMP-648-S/S	77428
1350	1200	MMP-654-S/S	77429
1500	1350	MMP-660-S/S	77430
1800	1650	MMP-672-S/S	77431
2100	1950	MMP-684-S/S	77432

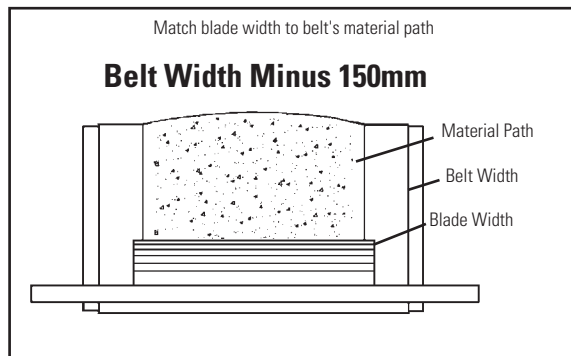

Product Notes:

- Recommended for medium-duty conveyor applications, but in corrosive environments.
- Material Path Option: Fit the blade width to the belt's material path. The material path is typically the center 2/3 of the belt width. In most cases a blade size of belt width minus 152 mm may be the best solution.
- Each cleaner pole is retrofittable for three blade sizes (belt width minus 152 mm, minus 305 mm or minus 457 mm).
- Pole Length: Belt width plus 1372 mm. For longer requirements see Installation Accessories - Pole Extender Kit.
- Visual Tension Check: No guesswork on blade tensioning. Measure the spring and adjust to specified length per blade width to restore optimal tensioning.
- To make cleaner installation easier and quicker, see Optional Mounting Kits.

Stock items (non-shaded) refer to (*) for specific lead time, if not specified, standard lead time applies.

Non-stock items (shaded) please contact Flexco for dispatch options and lead times.

U.S. Patent No. D482,508S

Replacement Parts List

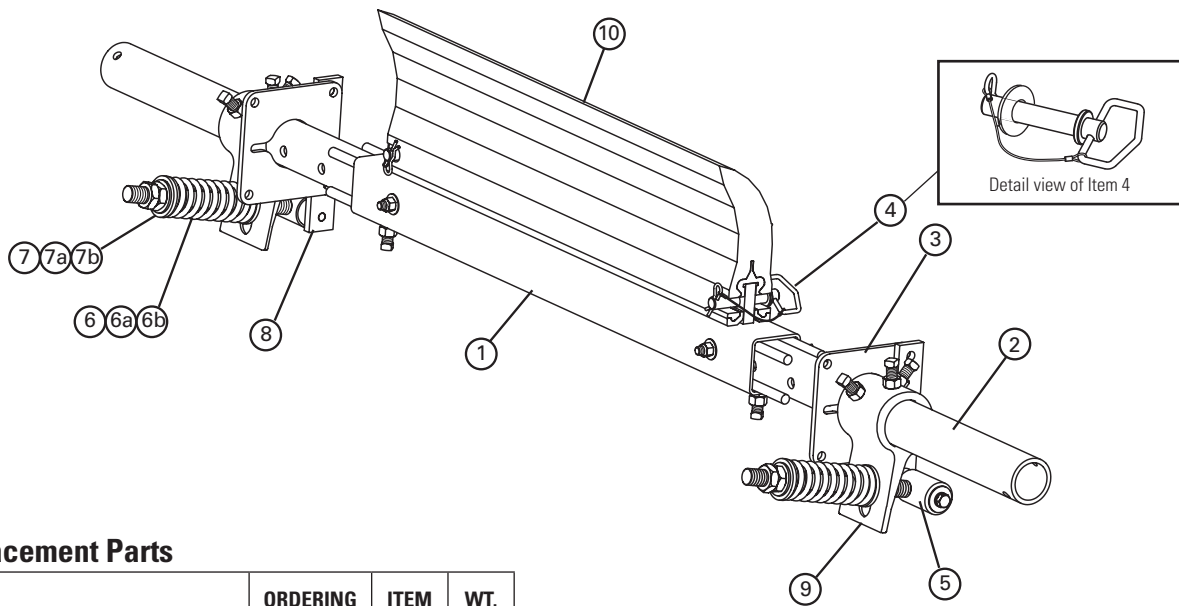

Replacement Parts

REF	DESCRIPTION	ORDERING NUMBER	ITEM CODE	WT. KG.
1	600 mm Pole	MMPCP24	76458	15.6
	750 mm Pole	MMPCP30	76459	19.6
	900 mm Pole	MMPCP36	76460	23.5
	1050 mm Pole	MMPCP42	76461	27.3
	1200 mm Pole	MMPCP48	76462	31.2
	1350 mm Pole	MMPCP54	76463	35.1
	1500 mm Pole	MMPCP60	76464	39.1
	1800 mm Pole	MMPCP72	76465	46.9
	2100 mm Pole	MMPCP84	76808	54.7
2	Extender Pole Kit (2 ea.)	MHP-EP	76392	24.6
3	Mounting Plate Kit* (2 ea.)	MSPMPK	75811	3.8
4	Blade Pin Kit* (1 ea.)	MMPBPK	76466	0.4
5	Pivot Arm Kit* (1 ea.)	QMTPAK	76096	2.0
6	Tension Spring - Purple (1 ea.) for blades 600 mm	QMTS-P	75845	0.3
6a	Tension Spring - White (1 ea.) for blades 750 - 1200 mm	PSTS-W	75898	0.8
6b	Tension Spring - Gold (1 ea.) for blades 1350 - 1950 mm	QMTS-G	76484	1.1
7	Bushing Kit - Purple (2 ea.)	QMTBK-P	76097	0.1
7a	Bushing Kit - White (2 ea.)	QMTBK-W	76098	0.1
7b	Bushing Kit - Gold (2 ea.)	QMTBK-G	76540	0.1
8	Pivot Shaft Bracket Kit* (1 ea.)	QMTPSBK	76099	2.0
9	Torsion Arm Kit* (1 ea.)	PSTA	75896	5.2
-	QMT Spring Tensioner* - Purple (incl. 1 ea. Items 5, 6, 7, 8, & 9) for blades 450 - 600 mm	QMT-P	76074	9.3
-	QMT Spring Tensioner* - White (incl. 1 ea. Items 5, 6a, 7a, 8, & 9) for blades 750 - 1200 mm	QMT-W	76075	10.0
-	QMT Spring Tensioner* - Gold (incl. 1 ea. Items 5, 6b, 7b, 8, & 9) for blades 1350 - 1950 mm	QMT-G	76483	10.6

*Hardware Included

Replacement TuffShear™ Blades

REF	BLADE WIDTH mm	ORDERING NUMBER	ITEM CODE	WT. KG.
10	450	TRB18	76485	9.6
	600	TRB24	76486	12.7
	750	TRB30	76487	16.0
	900	TRB36	76488	19.1
	1050	TRB42	76489	22.3
	1200	TRB48	76490	25.5
	1350	TRB54	76491	28.6
	1500	TRB60	76492	31.8
	1650	TRB66	76493	35.0
	1800	TRB72	76494	38.2
	1950	TRB78	76697	41.4
	2100	TRB84	77047	44.5
	2400	TRB90	77048	47.6

Order blade width for your belt width's material path:
Belt Width Minus 152 mm, Belt Width Minus 305 mm, or Belt Width Minus 457 mm.

Spring Tensioner Selection Chart

CLEANER BLADE WIDTH	76403 EST-P	76404 EST-S	76405 EST-B
TuffShear 450 - 600 mm	X		
TuffShear 750 - 1200 mm		X	
TuffShear 1350 - 1950 mm			X

Stock items (non-shaded) refer to (*) for specific lead time, if not specified, standard lead time applies.

Non-stock items (shaded) please contact Flexco for dispatch options and lead times.

U.S. Patent No. D482,508S

Replacement Parts List

MMP
Medium Mine-Duty Primary Cleaner

Air/Water Tensioner Replacement Parts

REF	DESCRIPTION	ORDERING NUMBER	ITEM CODE	WT. KG.
12	Air/Water Bag (1 ea.)	AWTB	75905	1.7
13	Mounting Base (1 ea.)	AWTMB	75906	10.4
14	Torque Arm* (1 ea.)	AWTA	75907	5.3
15	Hose Kit (15 M of hose and 6 hose clamps)	AWTHK	75909	3.1
16	Control Box (Complete)	AWTCB	75908	0.5
-	AWT Air/Water Tensioner (includes 2 each items 12, 13, & 14 and 1 each items 15 & 16)	AWT	75904	39.2
-	AWT Air/Water Tensioner w/o Control Box (includes 2 each items 12, 13, 14 & 1 each item 15)	AWTNCB	76069	34.2
-	AWT Air/Water Tensioner w/o Control Box, 1 side (includes 1 each items 12, 13, 14 & 15)	AWT-1S	76375	17.1

*Hardware Included

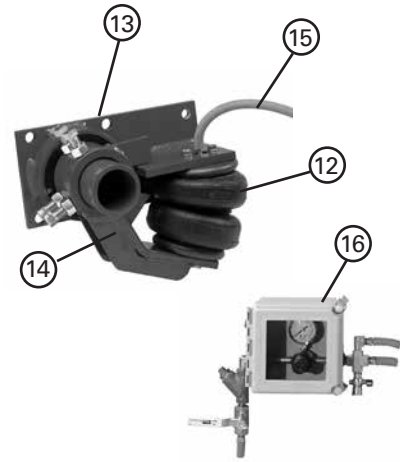

Stock items (non-shaded) refer to (*) for specific lead time, if not specified, standard lead time applies.

Non-stock items (shaded) please contact Flexco for dispatch options and lead times.

Replacement Parts List

Stainless Steel MMP Medium Mine-Duty Primary Cleaner

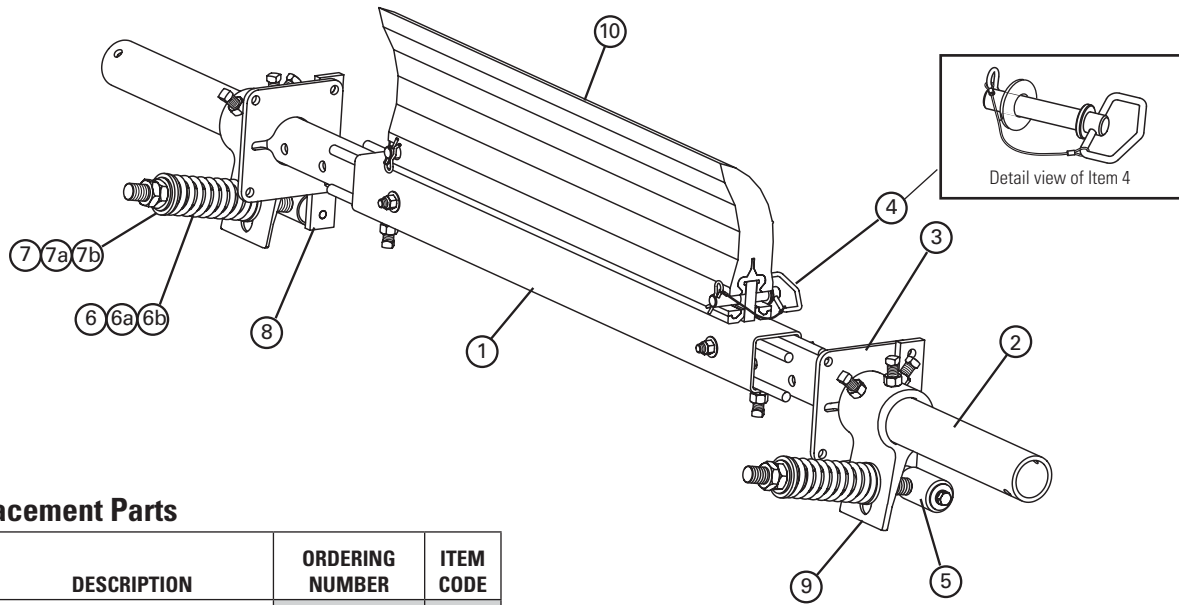

Replacement Parts

REF	DESCRIPTION	ORDERING NUMBER	ITEM CODE
1	600 mm SS Pole	MMPCP24-S/S	77590
	750 mm SS Pole	MMPCP30-S/S	77591
	900 mm SS Pole	MMPCP36-S/S	77592
	1050 mm SS Pole	MMPCP42-S/S	77593
	1200 mm SS Pole	MMPCP48-S/S	77594
	1350 mm SS Pole	MMPCP54-S/S	77595
	1500 mm SS Pole	MMPCP60-S/S	77596
	1800 mm SS Pole	MMPCP72-S/S	77597
	2100 mm SS Pole	MMPCP84-S/S	77598
2	SS Extender Pole Kit (2 ea.)	MHP-EP-S/S	77599
3	SS Mounting Plate Kit* (2 ea.)	MSPMPK-S/S	77582
4	SS Blade Pin Kit* (1 ea.)	MMPBPK-S/S	77600
5	SS Pivot Arm Kit* (1 ea.)	QMTPAK-S/S	77587
6	SS Tension Spring - Purple (1 ea.) for blades 600 mm	QMTS-P-S/S	77450
6a	SS Tension Spring - White (1 ea.) for blades 750 - 1200 mm	QSTS-W-S/S	77451
6b	SS Tension Spring - Gold (1 ea.) for blades 1350 - 1950 mm	QMTS-G-S/S	77452
7	Bushing Kit - Purple (2 ea.)	QMTBK-P	76097
7a	Bushing Kit - White (2 ea.)	QMTBK-W	76098
7b	Bushing Kit - Gold (2 ea.)	QMTBK-G	76540
8	SS Pivot Shaft Bracket Kit* (1 ea.)	QMTPSBK-S/S	77588
9	SS Torsion Arm Kit* (1 ea.)	PSTA-S/S	77442
-	SS QMT Spring Tensioner* - Purple (incl. 1 ea. Items 5, 6, 7, 8, & 9) for blades 450 - 600 mm	QMT-P-S/S	77584
-	SS QMT Spring Tensioner* - White (incl. 1 ea. Items 5, 6a, 7a, 8, & 9) for blades 750 - 1200 mm	QMT-W-S/S	77585
-	SS QMT Spring Tensioner* - Gold (incl. 1 ea. Items 5, 6b, 7b, 8, & 9) for blades 1350 - 1950 mm	QMT-G-S/S	77586

*Hardware Included

Replacement TuffShear™ Blades

REF	BLADE WIDTH mm	ORDERING NUMBER	ITEM CODE	WT. KG.
10	450	TRB18	76485	9.6
	600	TRB24	76486	12.7
	750	TRB30	76487	16.0
	900	TRB36	76488	19.1
	1050	TRB42	76489	22.3
	1200	TRB48	76490	25.5
	1350	TRB54	76491	28.6
	1500	TRB60	76492	31.8
	1650	TRB66	76493	35.0
	1800	TRB72	76494	38.2
	1950	TRB78	76697	41.4
	2100	TRB84	77047	44.5
	2400	TRB90	77048	47.6

Order blade width for your belt width's material path:
Belt Width Minus 152 mm, Belt Width Minus 305 mm, or
Belt Width Minus 457 mm.

Spring Tensioner Selection Chart

CLEANER BLADE WIDTH	76403 EST-P	76404 EST-S	76405 EST-B
TuffShear™ 450 - 600 mm	X		
TuffShear 750 - 1200 mm		X	
TuffShear 1350 - 1950 mm			X

Stock items (non-shaded) refer to (*) for specific lead time, if not specified, standard lead time applies.

Non-stock items (shaded) please contact Flexco for dispatch options and lead times.

U.S. Patent No. D482,508S

Specifications & Guidelines

Pole Length Specifications*

BELT WIDTH mm	MAX OVERALL POLE LENGTH mm	CENTRE POLE LENGTH mm	MAXIMUM CONVEYOR SPAN mm
600	1950	600	1650
750	2100	750	1800
900	2250	900	1950
1050	2400	1050	2100
1200	2550	1200	2250
1350	2700	1350	2400
1500	2850	1500	2550
1800	3150	1800	2850
2100	3450	2100	3150

* For special extra long pole length requirements a Pole Extender Kit (#76024) is available that provides 750 mm of extended pole length. Pole Diameter -73 mm

Clearance Guidelines for Installation

HORIZONTAL CLEARANCE REQUIRED mm	VERTICAL CLEARANCE REQUIRED mm
100	325

Spring Length Chart with QMT Spring Tensioner

BLADE WIDTH mm	PURPLE SPRINGS mm	WHITE SPRINGS mm	GOLD SPRINGS mm
450	110	150	160
600	100	140	150
750	N/A	140	150
900	N/A	130	150
1050	N/A	130	140
1200	N/A	130	140
1350	N/A	120	140
1500	N/A	120	140
1650	N/A	N/A	130
1800	N/A	N/A	130
1950	N/A	N/A	130
2100	N/A	N/A	N/A
2250	N/A	N/A	N/A

Shading indicates preferred spring option

Specifications:

- Maximum Belt Speed Contact Flexco®
- Temperature Rating -35°C to 82°C
- Minimum Pulley Diameter..... 400 mm
- Usable Blade Wear Length..... 150 mm
- Blade Polyurethane (proprietary blend for abrasion resistance and long wear)
- Available for Belt Widths 600 to 2100 mm
Other sizes available upon request

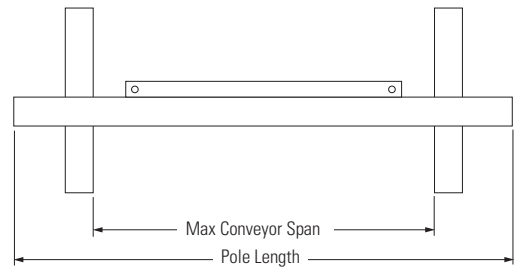

Pole Location Specs

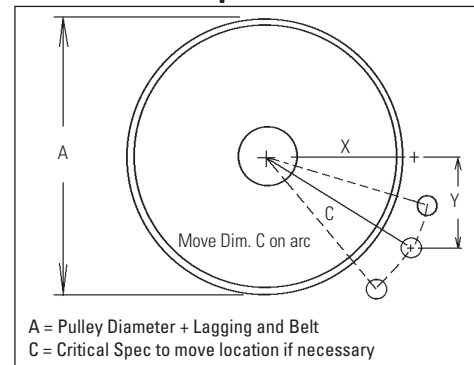

Pole Location Chart

A	X	Y	C
406	207	305	368
432	222	305	378
457	235	305	384
483	248	305	394
508	264	305	403
533	279	305	413
559	292	305	422
584	305	305	432
610	321	305	441
635	334	305	451
660	346	305	461
686	359	305	470
711	372	305	480
737	387	305	492
762	397	305	502
787	410	305	511
813	425	305	524
838	438	305	533
864	451	305	543
889	464	305	556
914	476	305	565
940	492	305	578
965	502	305	588
991	518	305	600
1016	527	305	610
1041	543	305	622
1067	552	305	632
1092	568	305	645
1118	578	305	654
1143	594	305	667
1168	607	305	679
1194	619	305	689
1219	632	305	702

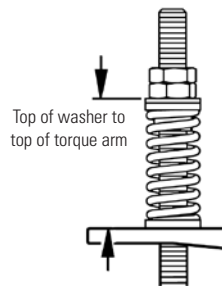
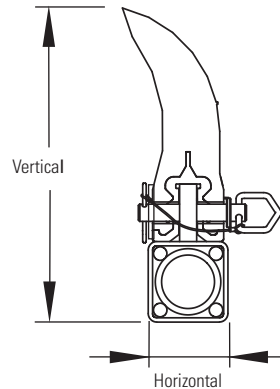

Product Ordering Information

Line Connections for Portable Air Tensioner

ORDERING NUMBER	ITEM CODE	WT. LBS.
PAT1	78684	13.0
PAT2	78685	13.0



PAT1 (Single)



PAT2 (Dual)

REF	DESCRIPTION	ORDERING NUMBER	ITEM CODE	WT. LBS.
1	Tank Label Kit	PATLK	78791	0.1
2	Tank Hose Kit (incl. 1 ea. 10' hose and 1' poly spiral wrap, 2 hose clamps)	PATHK	78794	1.5

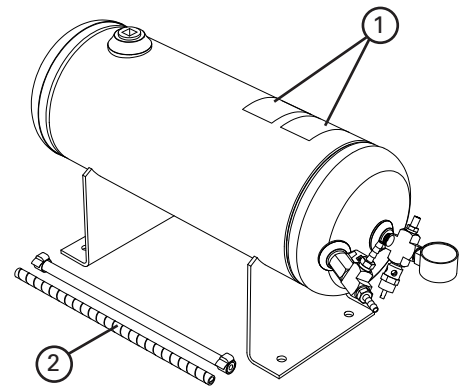

Product Notes:

- For use with PAT cleaner assemblies and PAT control box.
- Single for applications with one cleaner, double for applications with two cleaners.
- 150# pop-off valve for safe pressurizing/charging of Air Tank.
- ASME Construction.

Stock items (non-shaded) refer to (*) for specific lead time, if not specified, standard lead time applies.

Non-stock items (shaded) please contact Flexco for dispatch options and lead times.

Product Ordering Information

MHCP Heavy-Duty Cartridge Primary Cleaner

MHCP HD Cartridge Primary Cleaner with Spring Tensioner (PST)

BELT WIDTH mm	BLADE COVERAGE mm	ORDERING NUMBER	ITEM CODE	WT. KG.
600	450	MHCP-24S	75929	87.3
750	600	MHCP-30S	75930	94.2
900	750	MHCP-36S	75931	101.1
1050	900	MHCP-42S	75932	107.9
1200	1050	MHCP-48S	75933	114.8
1350	1200	MHCP-54S	75934	121.6
1500	1350	MHCP-60S	75935	128.5
1800	1650	MHCP-72S	75936	142.2
2100	1950	MHCP-84S	76800	165.9

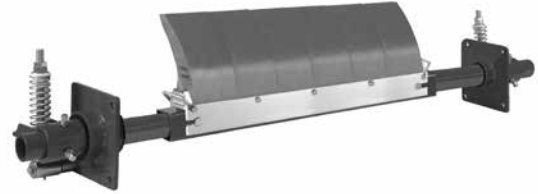

Mild Steel Model Pictured

MHCP HD Cartridge Primary Cleaner with Air/Water Tensioner (AWT)*

BELT WIDTH mm	BLADE COVERAGE mm	ORDERING NUMBER	ITEM CODE	WT. KG.
600	450	MHCP-24A	75937	87.4
750	600	MHCP-30A	75938	94.2
900	750	MHCP-36A	75939	101.1
1050	900	MHCP-42A	75940	107.9
1200	1050	MHCP-48A	75941	114.8
1350	1200	MHCP-54A	75942	121.6
1500	1350	MHCP-60A	75943	128.5
1800	1650	MHCP-72A	75944	142.2
2100	1950	MHCP-84A	76801	165.9



Mild Steel Model Pictured

Product Notes:

- Heavy-duty design with massive SuperShear™ blades for constant cleaning power on abusive beltlines.
- Blade width equals Belt Width minus 150 mm. Can be adjusted to belt's material path.
- Pole Length: Belt Width plus 1450 mm. For longer requirements see Mineliner® Installation Accessories - Pole Extender Kit .
- Tensioner Options: 1) PST Spring Tensioner for self-adjusting tensioning with easy retensioning adjustments; 2) AWT Air/Water Tensioner for automatic tensioning throughout the life of the blades.

Stock items (non-shaded) refer to (*) for specific lead time, if not specified, standard lead time applies.

Non-stock items (shaded) please contact Flexco for dispatch options and lead times.

Specifications & Guidelines

MHCP Heavy-Duty Cartridge Primary Cleaner

Telescoping Pole Length Specifications

CLEANER SIZE mm	MAX OVERALL POLE LENGTH ITEM CODE mm	CENTRE POLE LENGTH mm	MAXIMUM CONVEYOR SPAN mm
600	2050	700	1650
750	2200	850	1800
900	2350	1000	1950
1050	2500	1150	2100
1200	2650	1300	2250
1350	2800	1450	2400
1500	2950	1600	2550
1800	3250	1900	2850
2100	3550	2200	3150

Pole Diameter - 73 mm

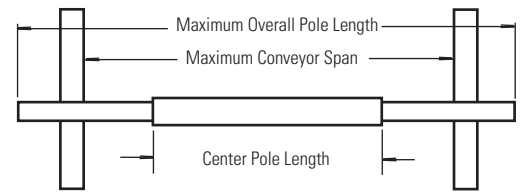

Pole Location Specs

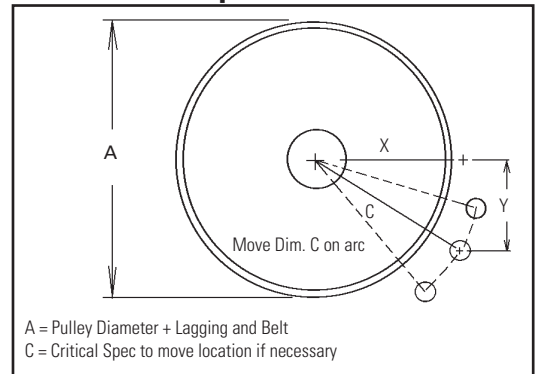

Clearance Guidelines for Installation

HORIZONTAL CLEARANCE REQUIRED mm	VERTICAL CLEARANCE REQUIRED mm
175	475

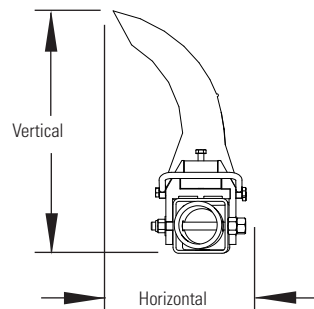

Spring Length Chart with PST Spring Tensioner

BLADE WIDTH mm	NO. OF BLADES	WHITE SPRINGS mm	SILVER SPRINGS mm
450	3	140	160
600	4	130	150
750	5	130	150
900	6	120	150
1050	7	110	150
1200	8	N/A	140
1350	9	N/A	140
1500	10	N/A	140
1650	11	N/A	140
1800	12	N/A	130
1950	13	N/A	130

Shading indicates preferred spring option
Spring tension is based on the number of blades on the cleaner, not the Belt Width.

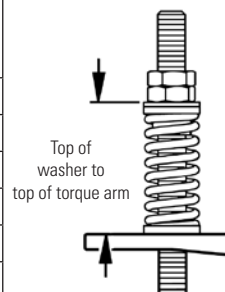

Air/Water Chart

BLADE WIDTH mm	BLADES	PSI
450	3	8#
600	4	10#
750	5	13#
900	6	15#
1050	7	18#
1200	8	20#
1350	9	23#
1500	10	25#
1650	11	28#
1950	12	31#

PSI setting is based on the number of blades on the cleaner, not the Belt Width.

Pole Location Chart

A	X	Y	C
508	254	365	445
533	267	365	451
559	279	365	461
584	292	365	467
610	305	365	476
635	318	365	483
660	330	365	492
686	343	365	502
711	356	365	511
737	368	365	518
762	381	365	527
787	394	365	537
813	406	365	546
838	419	365	556
864	432	365	565
889	445	365	575
914	457	365	584
940	470	365	594
965	483	365	607
991	495	365	616
1016	508	365	626
1041	521	365	635
1067	533	365	648
1092	546	365	657
1118	559	365	667
1143	572	365	679
1168	584	365	689
1194	591	365	699
1219	610	365	711

Specifications:

- Maximum Belt SpeedContact Flexco®
- Temperature Rating-35°C to 82°C
- Minimum Pulley Diameter.....400 mm
- Usable Blade Wear Length.....200 mm
- BladesPolyurethane (proprietary blend for abrasion resistance and long wear)
- Available for Belt Widths600 to 2100 mm
Other sizes available upon request.

Replacement Parts List

MHCP Heavy-Duty Cartridge Primary Cleaner

Replacement Parts List

REF	DESCRIPTION	ORDERING NUMBER	ITEM CODE	WT. KG.
1	600 mm Centre Pole*	MHP-CP600	75961	8.6
	750 mm Centre Pole*	MHP-CP750	75962	10.5
	900 mm Centre Pole*	MHP-CP900	75963	12.4
	1050 mm Centre Pole*	MHP-CP1050	75964	14.2
	1200 mm Centre Pole*	MHP-CP1200	75965	16.1
	1350 mm Centre Pole*	MHP-CP1400	75966	17.9
	1500 mm Centre Pole*	MHP-CP1500	75967	19.8
	1800 mm Centre Pole*	MHP-CP1800	75968	23.5
	2100 mm Centre Pole*	MHP-CP2100	76811	27.4
2	MHCP Extender Poles (2 ea.)	MHP-EP	76392	24.6
3	SuperShear™ Blade	SSRB	75978	3.0
3a	SuperShear™ FRAS Blade	SSFRB	78456	3.0
4	600 mm 2-Piece Blade Cartridge*	MHCP-2BC24	76638	6.0
	750 mm 2-Piece Blade Cartridge*	MHCP-2BC30	76639	8.0
	900 mm 2-Piece Blade Cartridge*	MHCP-2BC36	76640	10.0
	1050 mm 2-Piece Blade Cartridge*	MHCP-2BC42	76641	12.0
	1200 mm 2-Piece Blade Cartridge*	MHCP-2BC48	76642	14.0
	1350 mm 2-Piece Blade Cartridge*	MHCP-2BC54	76643	16.0
	1500 mm 2-Piece Blade Cartridge*	MHCP-2BC60	76644	18.0
	1800 mm 2-Piece Blade Cartridge*	MHCP-2BC72	76645	22.0
	2100 mm 2-Piece Blade Cartridge*	MHCP-2BC84	76812	25.7
5	MHCP Cartridge Handle*	MHCP-CH	76393	0.2
6	MHCP Cartridge Blade Stop*	MHCP-BS	76394	0.2



Blades Required per Belt Width

BELT WIDTH mm	BLADE COVERAGE mm	BLADES REQUIRED
600	450	3
750	600	4
900	750	5
1050	900	6
1200	1050	7
1350	1200	8
1500	1350	9
1800	1650	11
2100	1950	13

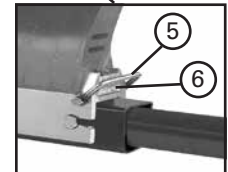

Blades and cartridges can be purchased separately (see chart at left) or preassembled as a Blade Cartridge Kit

PST Spring Tensioner Replacement Parts

REF	DESCRIPTION	ORDERING NUMBER	ITEM CODE	WT. KG.
7	Mounting Base* (1 ea.)	PMB	75895	10.1
8	Torque Arm* (1 ea.)	PSTA	75896	5.1
9	Torque Pivot Kit (1 ea.) (no spring)	PTPK	75897	3.2
10	Tension Spring - White (1 ea.) for belts 600-1200 mm	PSTS-W	75898	0.8
10a	Tension Spring - Silver (1 ea.) for belts 1350-2100 mm	PSTS-S	75899	1.4
11	Bushing Kit (2 ea.) (for White & Silver Tensioners)	QMTBK-W	76098	0.1
	PST Spring Tensioner* - White (includes 2 each items 7, 8, 9, 10 & 11) for belts 600-1200 mm	PST-W	75893	39.1
	PST Spring Tensioner* - Silver (includes 2 each items 7, 8, 9, 10a & 11) for belts 1350-2100 mm	PST-S	75894	39.2

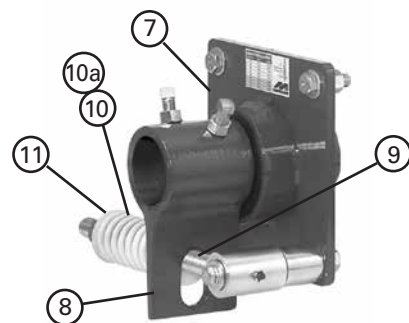

Air/Water Tensioner Replacement Parts

REF	DESCRIPTION	ORDERING NUMBER	ITEM CODE	WT. KG.
12	Air/Water Bag (1 ea.)	AWTB	75905	1.7
13	Mounting Base (1 ea.)	AWTMB	75906	10.4
14	Torque Arm* (1 ea.)	AWTA	75907	5.3
15	Hose Kit (15 M of hose and 6 hose clamps)	AWTHK	75909	3.1
16	Control Box (Complete)	AWTCB	75908	0.5
-	AWT Air/Water Tensioner (includes 2 each items 12, 13, & 14 and 1 each items 15 & 16)	AWT	75904	39.2
-	AWT Air/Water Tensioner w/o Control Box (includes 2 each items 12, 13, 14 & 1 each item 15)	AWTNCB	76069	34.2
-	AWT Air/Water Tensioner w/o Control Box, 1 side (includes 1 each items 12, 13, 14 & 15)	AWT-1S	76375	17.1

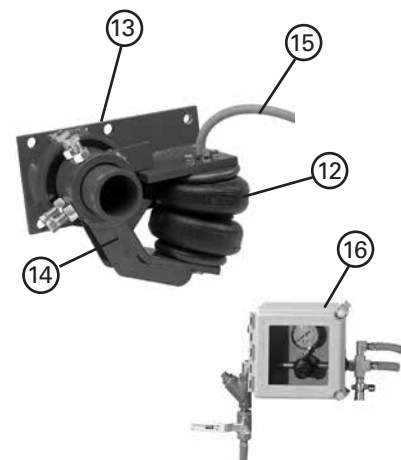

*Hardware Included

Stock items (non-shaded) refer to (*) for specific lead time, if not specified, standard lead time applies.

Non-stock items (shaded) please contact Flexco for dispatch options and lead times.

Product Ordering Information

MHCP Stainless Steel Heavy-Duty Cartridge Primary Cleaner

MHCP S/S HD Cartridge Primary Cleaner with Spring Tensioner (PST)

BELT WIDTH mm	ORDERING NUMBER	ITEM CODE	WT. KG.
600	MHCP-600S-S/S	61504	81.0
750	MHCP-750S-S/S	61505	89.4
900	MHCP-900S-S/S	61506	97.8
1050	MHCP-1050S-S/S	61507	108.1
1200	MHCP-1200S-S/S	61508	116.4
1350	MHCP-1350S-S/S	61509	124.8
1500	MHCP-1500S-S/S	61510	133.1
1650	MHCP-1650S-S/S	61511	141.4
1800	MHCP-1800S-S/S	61512	149.7
2100	MHCP-2100S-S/S	61513	166.7

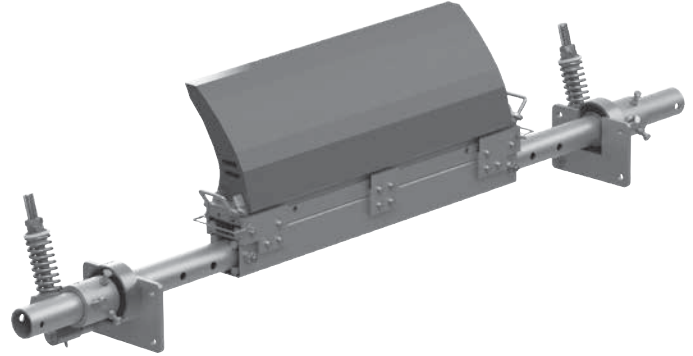

MHCP S/S FRAS HD Cartridge Primary Cleaner with Spring Tensioner (PST)

BELT WIDTH mm	ORDERING NUMBER	ITEM CODE	WT. KG.
600	MHCP-600S-S/S-FR	61624	81.0
750	MHCP-750S-S/S-FR	61625	89.4
900	MHCP-900S-S/S-FR	61626	97.8
1050	MHCP-1050S-S/S-FR	61627	108.1
1200	MHCP-1200S-S/S-FR	61628	116.4
1350	MHCP-1350S-S/S-FR	61629	124.8
1500	MHCP-1500S-S/S-FR	61630	133.1
1650	MHCP-1650S-S/S-FR	61631	141.4
1800	MHCP-1800S-S/S-FR	61632	149.7
2100	MHCP-2100S-S/S-FR	61633	166.7

Product Notes:

- Works with mechanical fasteners. The shock-absorbing tensioners and the force distributor vents in the blades allow mechanical splices, skived or unskived, to pass without damage to the splice or the cleaner and with minimal cleaning disruption..
- Complete cleaning system. When teamed with the MHS HD Secondary Cleaner, it makes up a system that delivers maximum cleaning power for the most abusive conveyor applications.
- Made for mining conveyors. Made from heavy-duty, corrosion-resistant steel, the MHCP is available in sizes for belt widths from 600 to 2100mm. Additional sizes are available upon request.
- Stainless steel. Corrosive environments wear on any component, but stainless steel can protect against that.

Stock items (non-shaded) refer to (*) for specific lead time, if not specified, standard lead time applies.

Non-stock items (shaded) please contact Flexco for dispatch options and lead times.

Specifications & Guidelines

MHCP Stainless Steel Heavy-Duty Cartridge Primary Cleaner

Telescoping Pole Length Specifications

Cleaner Size		Max Overall Pole Length		Centre Pole Length		Maximum Conveyor Span	
in.	mm	in.	mm	in.	mm	in.	mm
24	600	81	2020	20	511	65	1620
30	750	87	2173	27	663	71	1773
36	900	93	2325	33	815	77	1925
42	1050	99	2478	39	968	83	2078
48	1200	105	2630	45	1120	89	2230
54	1350	111	2783	51	1273	95	2383
60	1500	117	2935	57	1425	101	2535
66	1650	123	3087	63	1577	107	2687
72	1800	130	3240	69	1730	114	2840
84	2100	142	3545	81	2035	126	3145

Pole Diameter - 2-7/8" (73mm)

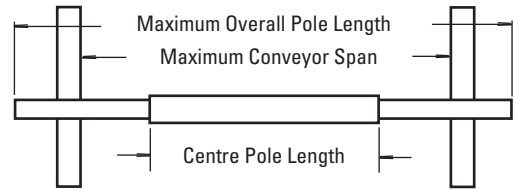

Clearance Guidelines for Installation

Horizontal Clearance Required		Vertical Clearance Required	
in.	mm	in.	mm
7	175	19	475

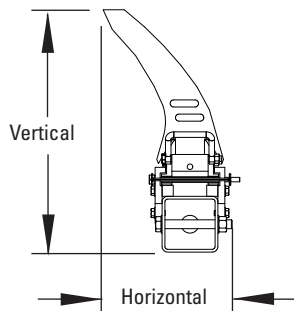

Spring Length Chart with PST Spring Tensioner

Blade Width	No. Of Blades	White Springs	Silver Springs
600	3	142	162
750	4	149	159
900	5	143	156
1050	6	140	156
1200	7	133	152
1350	8	N/A	149
1500	9	N/A	146
1650	10	N/A	146
1800	11	N/A	143
2100	13	N/A	140

Spring tension is based on the number of blades on the cleaner, not the belt width. Shading indicates preferred spring option.

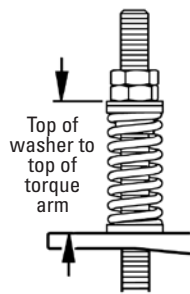

Pole Location Specs

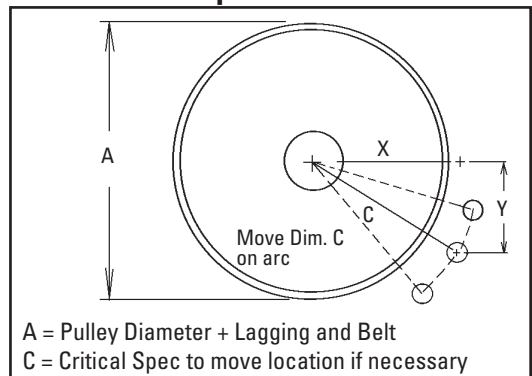

Pole Location Chart

A	X	C
500	229	473
525	242	479
550	254	486
575	267	492
600	279	499
625	292	506
650	304	514
675	317	521
700	329	529
725	342	537
750	354	545
775	367	553
800	379	561
825	392	570
850	404	578
875	417	587
900	429	596
925	442	605
950	454	614
975	467	624
1000	479	633
1025	492	643
1050	504	652
1075	517	662
1100	529	672
1125	542	682
1150	554	692
1175	567	702
1200	579	712

Specifications:

- Maximum Belt Speed6M/sec
- Temperature Rating-35°C to 82°C
- Minimum Pulley Diameter500mm
- Blade Height350mm
- Usable Blade Wear Length200mm
- BladesPolyurethane (proprietary blend for abrasion resistance and long wear).
- Available for Belt Widths.....600 to 2400mm.
Other sizes available upon request.

Replacement Parts List

MHCP Stainless Steel Heavy-Duty Cartridge Primary Cleaner

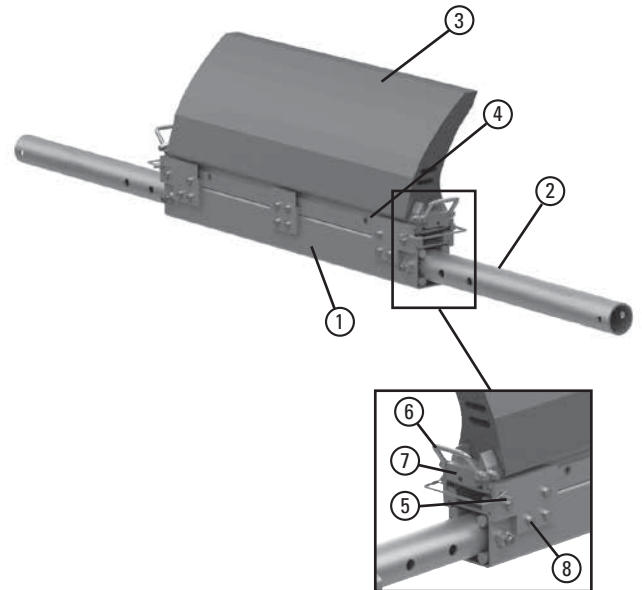

Replacement Parts

REF	DESCRIPTION	ORDERING NUMBER	ITEM CODE	WT. KG.
1	24" (600mm) Centre Pole*	MHCP-S/S-CP 600	61634	15.9
	30" (750mm) Centre Pole*	MHCP-S/S-CP 750	61525	19.1
	36" (900mm) Centre Pole*	MHCP-S/S-CP 900	61526	22.3
	42" (1050mm) Centre Pole*	MHCP-S/S-CP 1050	61527	27.4
	48" (1200mm) Centre Pole*	MHCP-S/S-CP 1200	61528	30.6
	54" (1350mm) Centre Pole*	MHCP-S/S-CP 1350	61529	33.8
	60" (1500mm) Centre Pole*	MHCP-S/S-CP 1500	61530	37.0
	66" (1650mm) Centre Pole*	MHCP-S/S-CP 1650	61531	40.2
	72" (1800mm) Centre Pole*	MHCP-S/S-CP 1800	61532	43.5
84" (2100mm) Centre Pole*	MHCP-S/S-CP 2100	61533	49.9	
2	MHCP S/S Extender Poles (2 ea.)	MHCP-SS/EP	61534	20.1
3	SuperShear™ Blade	SSRB	75978	3.0
3a	SuperShear™ FRAS Blade	SSFRB	78456	3.0
4	24" (600mm) Cartridge Kits*	MHCP-S/S-CK600	61535	9.3
	30" (750mm) Cartridge Kits*	MHCP-S/S-CK750	61536	11.7
	36" (900mm) Cartridge Kits*	MHCP-S/S-CK900	61537	14.0
	42" (1050mm) Cartridge Kits*	MHCP-S/S-CK1050	61538	16.3
	48" (1200mm) Cartridge Kits*	MHCP-S/S-CK1200	61539	18.6
	54" (1350mm) Cartridge Kits*	MHCP-S/S-CK1350	61540	21.0
	60" (1500mm) Cartridge Kits*	MHCP-S/S-CK1500	61541	23.3
	66" (1650mm) Cartridge Kits*	MHCP-S/S-CK1650	61542	25.6
	72" (1800mm) Cartridge Kits*	MHCP-S/S-CK1800	61543	28.0
84" (2100mm) Cartridge Kits*	MHCP-S/S-CK2100	61544	32.3	
5	MHCP S/S Cartridge Locking Pin	MHCP-S/S-CLP	61545	0.1
6	MHCP S/S Cartridge Handle*	MHCP-S/S-CH	61548	0.1
7	MHCP S/S Cartridge End Block*	MHCP-S/S-CEB	61549	0.5
8	MHCP S/S Cartridge Bolt Kit	MHCP-S/S-CBK	61550	0.1

*Hardware Included

Blades Required per Belt Width

Belt Width		Blades Required
in.	mm	
24	600	3
30	750	4
36	900	5
42	1050	6
48	1200	7
54	1350	8
60	1500	9
66	1650	10
72	1800	11
84	2100	13

Blades and cartridges can be purchased separately (see chart at left) or preassembled as a Blade Cartridge Kit.

PST Spring Tensioner Replacement Parts

REF	DESCRIPTION	ORDERING NUMBER	ITEM CODE	WT. KG.
9	Tension Spring - White (1 ea.) for belts 24" - 48" (600-1200mm)	PSTS-W	75898	0.8
9a	Tension Spring - Silver (1 ea.) for belts 54" - 96" (1350-2400mm)	PSTS-S	75899	1.4
10	Bushing Kit (2 ea.) for White & Silver Tensioners	QMTBK-W	76098	0.2
-	PST Spring Tensioner* - White (includes 2 ea.) for belts 600-1200mm (24" - 48")	MHCP-S/S-PSTW	61546	27.6
-	PST Spring Tensioner* - Silver (includes 2 ea.) for belts 1350-2400mm (54" - 96")	MHCP-S/S-PSTS	61547	27.7

*Hardware Included

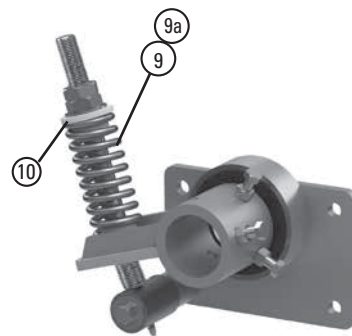

Product Ordering Information

H-Type® with XF-Tips Segmented Blade Primary Cleaner

H-Type® with XF-Tips Powder Coated

BELT WIDTH mm	HF-TIP SIZE	ORDERING NUMBER	ITEM CODE	WT. KG.
450	S	HXF450S	74659	35.0
450	M	HXF450M	74660	
600	S	HXF600S	74661	41.0
600	M	HXF600M	74662	
750	S	HXF750S	74663	42.0
750	M	HXF750M	74664	
900	S	HXF900S	74665	47.0
900	M	HXF900M	74666	
900	L	HXF900L	74667	
1050	S	HXF1050S	74668	60.0
1050	M	HXF1050M	74669	
1050	L	HXF1050L	74670	
1200	S	HXF1200S	74671	62.0
1200	M	HXF1200M	74672	
1200	L	HXF1200L	74673	
1500	M	HXF1500M	74677	75.0
1500	L	HXF1500L	74678	
1600	M	HXF1600M	73443	80.0
1600	L	HXF1600L	73444	
1800	M	HXFHD1800M	74681	105.0
1800	L	HXFHD1800L	74682	
2100	M	HXFHD2100M	74683	110.0
2100	L	HXFHD2100L	74684	
2400	M	HXFHD2400M	74685	120.0
2400	L	HXFHD2400L	74686	

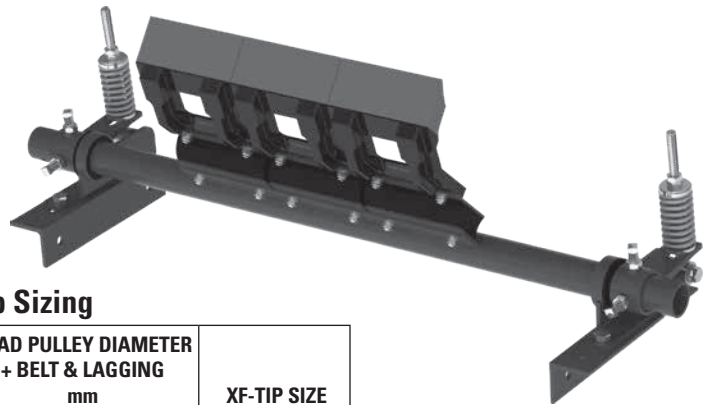

Tip Sizing

HEAD PULLEY DIAMETER + BELT & LAGGING mm	XF-TIP SIZE
up to 499	SS
500-799	S
800-999	M
1000-1200	L

Over 1200 mm - contact Flexco®.

Replacement XF8-Non-FRAS Tips

SIZE	ORDERING NUMBER	COLOUR	ITEM CODE	WT. KG.
SS	HXF8SS	Purple	74307	1.5
S	HXF8S	Purple	74689	1.7
M	HXF8M	Purple	74690	1.8
L	HXF8L	Purple	74691	2.0



Replacement XF8-FRAS Tips

SIZE	ORDERING NUMBER	COLOUR	ITEM CODE	WT. KG.
SS	HXF8SS-Blue	Blue	77518	2.0
S	HXF8S-Blue	Blue	77519	2.0
M	HXF8M-Blue	Blue	77520	2.0
L	HXF8L-Blue	Blue	77521	2.5



Replacement XF2-Non-FRAS Tips

SIZE	ORDERING NUMBER	COLOUR	ITEM CODE	WT. KG.
SS	HXF2-SS	Purple	75979	1.5
S	HXF2-S	Purple	75980	1.5
M	HXF2-M	Purple	75981	1.5
L	HXF2-L	Purple	75982	2.0

Specially formulated, long-wearing polyurethane blade tip.
Impact-resistant, reinforced nylon base for rigidity and minimal deflection.

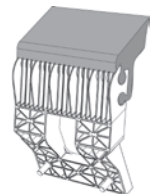

Tips Required Per Cleaner Size

BELT WIDTH mm	BLADE COVERAGE mm	XF-TIPS REQUIRED
450	400	2
600	600	3
750	600	3
900	800	4
1050	1000	5
1200	1200	6
1500	1400	7
1600	1600	8
1800	1800	9
2100	2000	10
2400	2400	12

Product Notes:

- All cleaners supplied with dual tensioners.
- Also available with J-Bolt Side Assembly.
- Standard supply is non-FRAS.
- Specify when ordering FRAS.
- Specify arm size when ordering.
- For replacement parts refer to page 42.

Stock items (non-shaded) refer to (*) for specific lead time, if not specified, standard lead time applies.

Non-stock items (shaded) please contact Flexco for dispatch options and lead times.

Product Ordering Information

H-Type® with XF-Tips Segmented Blade Primary Cleaner Stainless Steel

H-Type® with XF-Tips Stainless Steel

BELT WIDTH mm	XF2-TIP SIZE	ORDERING NUMBER	ITEM CODE	WT. KG.
450	S	HXF450S-S/S	75266	35.0
450	M	HXF450M-S/S	75267	
600	S	HXF600S-S/S	75268	42.0
600	M	HXF600M-S/S	75269	
750	S	HXF750S-S/S	75270	43.0
750	M	HXF750M-S/S	75271	
900	S	HXF900S-S/S	75272	49.0
900	M	HXF900M-S/S	75273	
900	L	HXF900L-S/S	75274	
1050	S	HXF1050S-S/S	75275	62.0
1050	M	HXF1050M-S/S	75276	
1050	L	HXF1050L-S/S	75277	
1200	S	HXF1200S-S/S	75278	63.0
1200	M	HXF1200M-S/S	75279	
1200	L	HXF1200L-S/S	75280	
1500	M	HXF1500M-S/S	75281	77.0
1500	L	HXF1500L-S/S	75282	
1600	M	HXF1600M-S/S	75283	82.0
1600	L	HXF1600L-S/S	75284	
1800	M	HXFHD1800M-S/S	A1588	107.0
1800	L	HXFHD1800L-S/S	A1589	
2100	M	HXFHD2100M-S/S	A1590	112.0
2100	L	HXFHD2100L-S/S	A1591	
2400	M	HXFHD2400M-S/S	A1592	122.0
2400	L	HXFHD2400L-S/S	A1593	

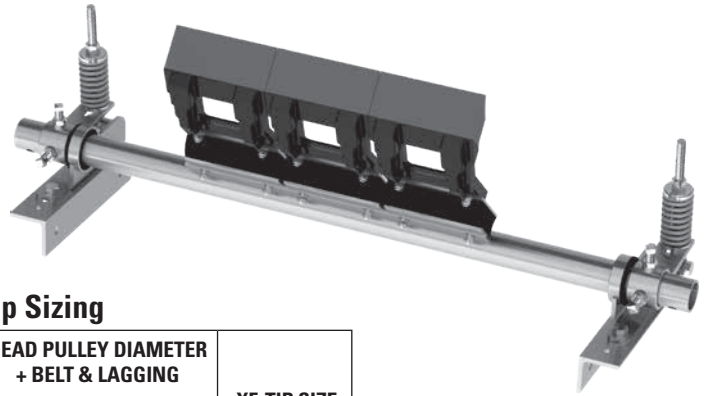

Tip Sizing

HEAD PULLEY DIAMETER + BELT & LAGGING mm	XF-TIP SIZE
up to 499	SS
500-799	S
800-999	M
1000-1200	L

Over 1200 mm- contact Flexco®.

Replacement XF8-Non-FRAS Tips

SIZE	ORDERING NUMBER	COLOUR	ITEM CODE	WT. KG.
SS	HXF8SS	Purple	74307	1.5
S	HXF8S	Purple	74689	1.7
M	HXF8M	Purple	74690	1.8
L	HXF8L	Purple	74691	2.0



Replacement XF8-FRAS Tips

SIZE	ORDERING NUMBER	COLOUR	ITEM CODE	WT. KG.
SS	HXF8SS-Blue	Blue	77518	2.0
S	HXF8S-Blue	Blue	77519	2.0
M	HXF8M-Blue	Blue	77520	2.0
L	HXF8L-Blue	Blue	77521	2.5



Replacement XF2-Non-FRAS Tips

SIZE	ORDERING NUMBER	COLOUR	ITEM CODE	WT. KG.
SS	HXF2-SS	Purple	75979	1.5
S	HXF2-S	Purple	75980	1.5
M	HXF2-M	Purple	75981	1.5
L	HXF2-L	Purple	75982	2.0

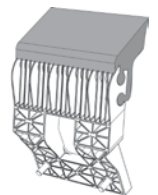

Specially formulated, long-wearing polyurethane blade tip. Impact-resistant, reinforced nylon base for rigidity and minimal deflection.

Tips Required Per Cleaner Size

BELT WIDTH mm	BLADE COVERAGE mm	XF-TIPS REQUIRED
450	400	2
600	600	3
750	600	3
900	800	4
1050	1000	5
1200	1200	6
1500	1400	7
1600	1600	8
1800	1800	9
2100	2000	10
2400	2400	12

Product Notes:

- All cleaners supplied with dual tensioners.
- Also available with J-Bolt Side Assembly.
- Standard supply is non-FRAS.
- Specify when ordering FRAS.
- Specify arm size when ordering.
- For replacement parts refer to page 42.

Stock items (non-shaded) refer to (*) for specific lead time, if not specified, standard lead time applies.

Non-stock items (shaded) please contact Flexco for dispatch options and lead times.

Product Ordering Information

H-Type® with V-Tips Segmented Blade Primary Cleaner

H-Type® with V-Tips*-Powder Coated

BELT WIDTH mm	SUSPENSION ARM SIZE	ORDERING NUMBER	ITEM CODE	WT. KG.
450	SS	HV450SS	73026	30.0
450	S	HV450S	73028	
450	M	HV450M	73019	
600	SS	HV600SS	73045	35.0
600	S	HV600S	73030	
600	M	HV600M	73173	
750	SS	HV750SS	73053	37.0
750	S	HV750S	73032	
750	M	HV750M	73174	
900	SS	HV900SS	73055	42.0
900	S	HV900S	73034	
900	M	HV900M	73175	
900	L	HV900L	73178	46.0
1050	SS	HV1050SS	73057	
1050	S	HV1050S	73056	
1050	M	HV1050M	73036	50.0
1050	L	HV1050L	73179	
1200	SS	HV1200SS	73059	
1200	S	HV1200S	73058	64.0
1200	M	HV1200M	73038	
1200	L	HV1200L	73180	
1500	M	HV1500M	73177	68.0
1500	L	HV1500L	73158	
1500	LL	HV1500LL	73215	
1600	M	HV1600M	73637	95.0
1600	L	HV1600L	73638	
1600	LL	HV1600LL	73639	
1800	M	HVHD1800M	74602	102.0
1800	L	HVHD1800L	74477	
1800	LL	HVHD1800LL	74478	
2100	M	HVHD2100M	74539	118.0
2100	L	HVHD2100L	74540	
2100	LL	HVHD2100LL	74541	
2400	M	HVHD2400M	74544	125.0
2400	L	HVHD2400L	74545	
2400	LL	HVHD2400LL	74546	
2600	M	HVHD2600M	A2396	133.0
2600	L	HVHD2600L	A2461	
2600	LL	HVHD2600LL	A2397	
3000	M	HVHD3000M	74591	133.0
3000	L	HVHD3000L	74592	
3000	LL	HVHD3000LL	74593	

Specify arm size when ordering.



Suspension Arm Size

HEAD PULLEY DIAMETER + BELT & LAGGING mm	SUSPENSION ARM SIZE
up to 499	SS
500-799	S
800-999	M
1000-1199	L
1200-1700	LL

Over 1700 mm—contact Flexco®.

Replacement V-Tips

ORDERING NUMBER	ITEM CODE	WT. KG.
HSA200	73489	0.5
HVPT-S/S	73631	1.2

Replacement Suspension Arms

SIZE	ORDERING NUMBER	ITEM CODE	WT. KG.
SS	HSA8SS	73047	0.9
S	HSA8S	73048	1.1
M	HSA8M	73049	1.3
L	HSA8L	73063	1.5
LL	HSA8LL	73064	1.7

Tips Required Per Cleaner Size

BELT WIDTH mm	BLADE COVERAGE mm	V-TIPS REQUIRED
450	400	2
600	600	3
750	600	3
900	800	4
1050	1000	5
1200	1200	6
1500	1400	7
1600	1600	8
1800	1800	9
2100	2000	10
2400	2400	12
2600	2600	13
3000	3000	15

Stock items (non-shaded) refer to (*) for specific lead time, if not specified, standard lead time applies.

Non-stock items (shaded) please contact Flexco for dispatch options and lead times.

Product Ordering Information

H-Type® with V-Tips Segmented Blade Primary Cleaner Stainless Steel

H-Type® with V-Tips*-Stainless Steel

BELT WIDTH mm	SUSPENSION ARM SIZE	ORDERING NUMBER	ITEM CODE	WT. KG.
450	SS	HV450SS-S/S	75293	30.0
450	S	HV450S-S/S	75294	
450	M	HV450M-S/S	75295	
600	SS	HV600SS-S/S	75296	36.0
600	S	HV600S-S/S	75297	
600	M	HV600M-S/S	75298	
750	SS	HV750SS-S/S	75299	38.0
750	S	HV750S-S/S	75300	
750	M	HV750M-S/S	75301	
900	SS	HV900SS-S/S	75302	43.0
900	S	HV900S-S/S	75303	
900	M	HV900M-S/S	75304	
900	L	HV900L-S/S	75305	47.0
1050	SS	HV1050SS-S/S	75306	
1050	S	HV1050S-S/S	75307	
1050	M	HV1050M-S/S	75308	50.0
1050	L	HV1050L-S/S	75309	
1200	SS	HV1200SS-S/S	75310	
1200	S	HV1200S-S/S	75311	64.0
1200	M	HV1200M-S/S	75312	
1200	L	HV1200L-S/S	75313	
1500	M	HV1500M-S/S	75314	68.0
1500	L	HV1500L-S/S	75315	
1500	LL	HV1500LL-S/S	75316	
1600	M	HV1600M-S/S	75317	98.0
1600	L	HV1600L-S/S	75318	
1600	LL	HV1600LL-S/S	75319	
1800	M	HVHD1800M-S/S	A1594	104.0
1800	L	HVHD1800L-S/S	A1595	
1800	LL	HVHD1800LL-S/S	A1596	
2100	M	HVHD2100M-S/S	A1597	121.0
2100	L	HVHD2100L-S/S	A1598	
2100	LL	HVHD2100LL-S/S	A1599	
2400	M	HVHD2400M-S/S	A1600	125.0
2400	L	HVHD2400L-S/S	A1601	
2400	LL	HVHD2400LL-S/S	A1602	
2600	M	HVHD2600M-S/S	A2462	135.0
2600	L	HVHD2600L-S/S	A2463	
2600	LL	HVHD2600LL-S/S	A2464	
3000	M	HVHD3000M-S/S	A2465	
3000	L	HVHD3000L-S/S	A2466	
3000	LL	HVHD3000LL-S/S	A2467	

Specify arm size when ordering.

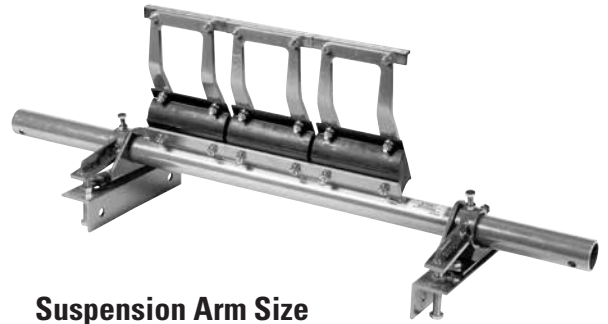

Suspension Arm Size

HEAD PULLEY DIAMETER + BELT & LAGGING mm	SUSPENSION ARM SIZE
up to 499	SS
500-799	S
800-999	M
1000-1199	L
1200-1700	LL

Over 1700 mm—contact Flexco®.

Replacement V-Tips

ORDERING NUMBER	ITEM CODE	WT. KG.
HVT8-S/S	75419	0.5
HVPT-S/S	73631	1.2

Replacement Suspension Arms

SIZE	ORDERING NUMBER	ITEM CODE	WT. KG.
SSS	HSA8SSS	75565	0.7
SS	HSA8SS-S/S	73771	0.9
S	HSA8S-S/S	73772	1.1
M	HSA8M-S/S	73773	1.3
L	HSA8L-S/S	73774	1.5
LL	HSA8LL-S/S	74033	1.7

Tips Required Per Cleaner Size

BELT WIDTH mm	BLADE COVERAGE mm	V-TIPS REQUIRED
450	400	2
600	600	3
750	600	3
900	800	4
1050	1000	5
1200	1200	6
1500	1400	7
1600	1600	8
1800	1800	9
2100	2000	10
2400	2400	12
2600	2600	13
3000	3000	15

Stock items (non-shaded) refer to (*) for specific lead time, if not specified, standard lead time applies.

Non-stock items (shaded) please contact Flexco for dispatch options and lead times.

Product Ordering Information

H-Type® with V-Tips and PCSTensioner Segmented Blade Primary Cleaner

H-Type® with V-Tips*-Powder Coated

BELT WIDTH mm	SUSPENSION ARM SIZE	ORDERING NUMBER	ITEM CODE	WT. KG.
450	SS	HV450SS-PCST	63936	36.8
450	S	HV450S-PCST	63937	
450	M	HV450M-PCST	63938	
600	SS	HV600SS-PCST	63939	41.8
600	S	HV600S-PCST	63940	
600	M	HV600M-PCST	63941	
750	SS	HV750SS-PCST	63942	43.8
750	S	HV750S-PCST	63943	
750	M	HV750M-PCST	63944	
900	SS	HV900SS-PCST	63945	48.8
900	S	HV900S-PCST	63946	
900	M	HV900M-PCST	63947	
900	L	HV900L-PCST	63948	52.8
1050	SS	HV1050SS-PCST	64045	
1050	S	HV1050S-PCST	63950	
1050	M	HV1050M-PCST	63951	56.8
1050	L	HV1050L-PCST	63952	
1200	SS	HV1200SS-PCST	63953	
1200	S	HV1200S-PCST	63954	70.8
1200	M	HV1200M-PCST	63955	
1200	L	HV1200L-PCST	63956	
1500	M	HV1500M-PCST	63957	74.8
1500	L	HV1500L-PCST	63958	
1500	LL	HV1500LL-PCST	63959	
1600	M	HV1600M-PCST	63960	101.8
1600	L	HV1600L-PCST	63961	
1600	LL	HV1600LL-PCST	63962	
1800	M	HV1800M-PCST	63963	108.8
1800	L	HV1800L-PCST	63964	
1800	LL	HV1800LL-PCST	63965	
2100	M	HV2100M-PCST	63966	125.0
2100	L	HV2100L-PCST	63967	
2100	LL	HV2100LL-PCST	63968	
2400	M	HV2400M-PCST	63969	132.0
2400	L	HV2400L-PCST	63970	
2400	LL	HV2400LL-PCST	63971	
2600	M	HV2600M-PCST	63972	140.0
2600	L	HV2600L-PCST	63973	
2600	LL	HV2600LL-PCST	63974	
3000	M	HV3000M-PCST	63975	
3000	L	HV3000L-PCST	63976	
3000	LL	HV3000LL-PCST	63977	

Specify arm size when ordering.

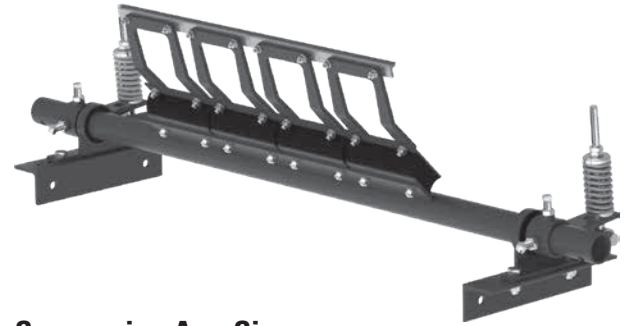

Suspension Arm Size

HEAD PULLEY DIAMETER + BELT & LAGGING mm	SUSPENSION ARM SIZE
up to 499	SS
500-799	S
800-999	M
1000-1199	L
1200-1700	LL

Over 1700 mm—contact Flexco®.

Replacement V-Tips

ORDERING NUMBER	ITEM CODE	WT. KG.
HSA200	73489	0.5
HVPT-S/S	73631	1.2

Replacement Suspension Arms

SIZE	ORDERING NUMBER	ITEM CODE	WT. KG.
SS	HSA8SS	73047	0.9
S	HSA8S	73048	1.1
M	HSA8M	73049	1.3
L	HSA8L	73063	1.5
LL	HSA8LL	73064	1.7

Tips Required Per Cleaner Size

BELT WIDTH mm	BLADE COVERAGE mm	V-TIPS REQUIRED
450	400	2
600	600	3
750	600	3
900	800	4
1050	1000	5
1200	1200	6
1500	1400	7
1600	1600	8
1800	1800	9
2100	2000	10
2400	2400	12
2600	2600	13
3000	3000	15

Stock items (non-shaded) refer to (*) for specific lead time, if not specified, standard lead time applies.

Non-stock items (shaded) please contact Flexco for dispatch options and lead times.

Product Ordering Information

H-Type® with V-Tips and PCST Tensioner Stainless Steel

H-Type® with V-Tips*-Stainless Steel

BELT WIDTH mm	SUSPENSION ARM SIZE	ORDERING NUMBER	ITEM CODE	WT. KG.
450	SS	HV450SS-PCST-S/S	63978	30.0
450	S	HV450S-PCST-S/S	63979	
450	M	HV450M-PCST-S/S	63980	
600	SS	HV600SS-PCST-S/S	63981	36.0
600	S	HV600S-PCST-S/S	63982	
600	M	HV600M-PCST-S/S	63983	
750	SS	HV750SS-PCST-S/S	63984	38.0
750	S	HV750S-PCST-S/S	63985	
750	M	HV750M-PCST-S/S	63986	
900	SS	HV900SS-PCST-S/S	63987	43.0
900	S	HV900S-PCST-S/S	63988	
900	M	HV900M-PCST-S/S	63989	
900	L	HV900L-PCST-S/S	63990	
1050	SS	HV1050SS-PCST-S/S	63991	47.0
1050	S	HV1050S-PCST-S/S	63992	
1050	M	HV1050M-PCST-S/S	63993	
1050	L	HV1050L-PCST-S/S	63994	
1200	SS	HV1200SS-PCST-S/S	63995	50.0
1200	S	HV1200S-PCST-S/S	63996	
1200	M	HV1200M-PCST-S/S	63997	
1200	L	HV1200L-PCST-S/S	63998	
1500	M	HV1500M-PCST-S/S	63999	64.0
1500	L	HV1500L-PCST-S/S	64000	
1500	LL	HV1500LL-PCST-S/S	64001	68.0
1600	M	HV1600M-PCST-S/S	64002	
1600	L	HV1600L-PCST-S/S	64003	98.0
1600	LL	HV1600LL-PCST-S/S	64004	
1800	M	HVHD1800M-PCST-S/S	64005	104.0
1800	L	HVHD1800L-PCST-S/S	64006	
1800	LL	HVHD1800LL-PCST-S/S	64007	
2100	M	HVHD2100M-PCST-S/S	64008	121.0
2100	L	HVHD2100L-PCST-S/S	64009	
2100	LL	HVHD2100LL-PCST-S/S	64010	
2400	M	HVHD2400M-PCST-S/S	64011	125.0
2400	L	HVHD2400L-PCST-S/S	64012	
2400	LL	HVHD2400LL-PCST-S/S	64013	
2600	M	HVHD2600M-PCST-S/S	64014	135.0
2600	L	HVHD2600L-PCST-S/S	64015	
2600	LL	HVHD2600LL-PCST-S/S	64016	
3000	M	HVHD3000M-PCST-S/S	64017	
3000	L	HVHD3000L-PCST-S/S	64018	
3000	LL	HVHD3000LL-PCST-S/S	64019	

Specify arm size when ordering.

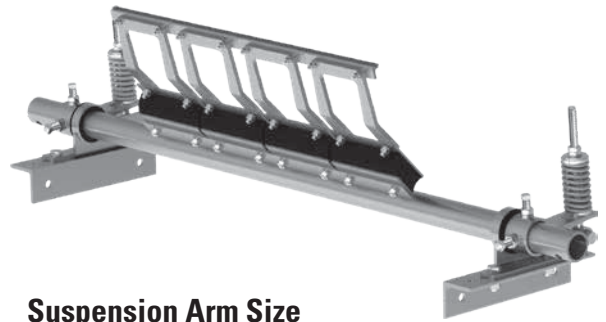

Suspension Arm Size

HEAD PULLEY DIAMETER + BELT & LAGGING mm	SUSPENSION ARM SIZE
up to 499	SS
500-799	S
800-999	M
1000-1199	L
1200-1700	LL

Over 1700 mm—contact Flexco®.

Replacement V-Tips

ORDERING NUMBER	ITEM CODE	WT. KG.
HVT8-S/S	75419	0.5
HVPT-S/S	73631	1.2

Replacement Suspension Arms

SIZE	ORDERING NUMBER	ITEM CODE	WT. KG.
SSS	HSA8SSS	75565	0.7
SS	HSA8SS-S/S	73771	0.9
S	HSA8S-S/S	73772	1.1
M	HSA8M-S/S	73773	1.3
L	HSA8L-S/S	73774	1.5
LL	HSA8LL-S/S	74033	1.7

Tips Required Per Cleaner Size

BELT WIDTH mm	BLADE COVERAGE mm	V-TIPS REQUIRED
450	400	2
600	600	3
750	600	3
900	800	4
1050	1000	5
1200	1200	6
1500	1400	7
1600	1600	8
1800	1800	9
2100	2000	10
2400	2400	12
2600	2600	13
3000	3000	15

Stock items (non-shaded) refer to (*) for specific lead time, if not specified, standard lead time applies.

Non-stock items (shaded) please contact Flexco for dispatch options and lead times.

Replacement Parts List

H-Type® Segmented Blade Primary Cleaners

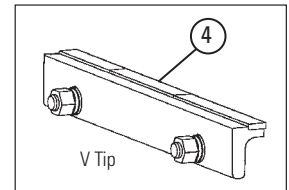
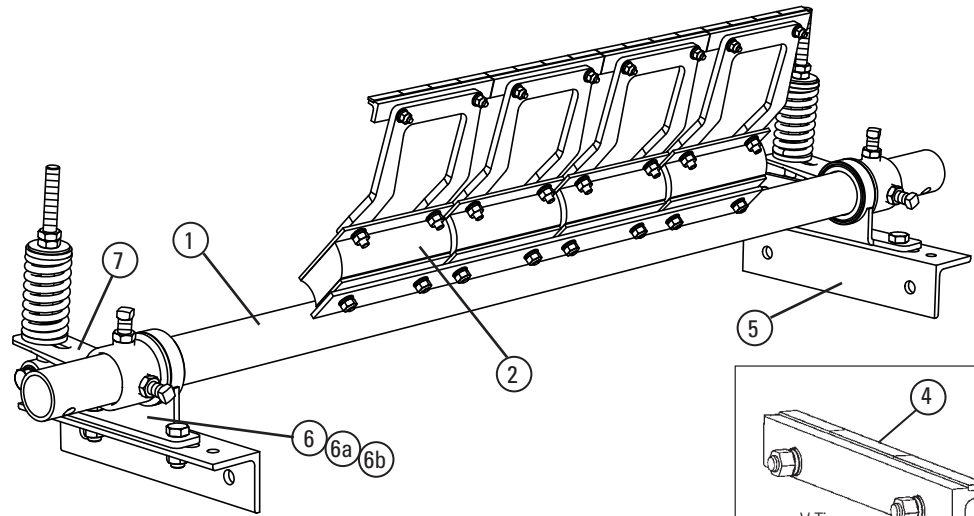
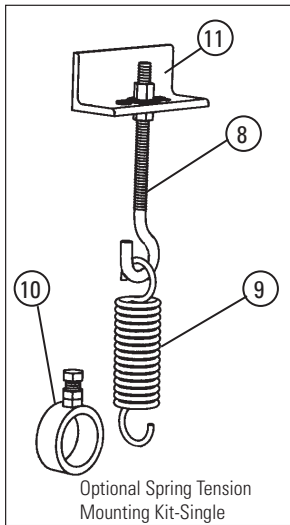

Replacement Parts

REF	DESCRIPTION	BELT WIDTH	POLE LENGTH (MM)	POWDER COATED			STAINLESS STEEL	
				ORDERING NUMBER	ITEM CODE	WT. KG.	ORDERING NUMBER	ITEM CODE
1	H-Type® Pole Standard-60 mm Pole Diameter	450	1250	HP450	73027	10.0	HP450-S/S	75373
		600	1350	HP600	73029	11.0	HP600-S/S	75374
		750	1500	HP750	73031	13.0	HP750-S/S	75375
		900	1650	HP900	73033	15.0	HP900-S/S	75376
		1050	1800	HP1050	73035	20.0	HP1050-S/S	75377
		1200	1950	HP1200	73037	22.0	HP1200-S/S	75378
	H-Type Pole Standard-73 mm Pole Diameter	1500	2350	HP1500	73066	24.0	HP1500-S/S	75379
		1600	2450	HP1600	73739	27.0	HP1600-S/S	75380
		H-Type Pole Heavy-Duty-73 mm Pole Diameter Braced and Gusseted	1800	2650	HPHD1800	74601	34.0	HPHD1800-S/S
2000	2950		HPHD2000	74547	39.0	HPHD2000-S/S	A1783	
2400	3250		HPHD2400	74548	43.5	HPHD2400-S/S	A2590	
2	Cushion			HSA	73486	2.0	HVC-S/S	73494
	Heavy-Duty Cushion			HSHD	73483	2.0	HSHD-S/S	76467
-	H Polyshield (Not shown)			HPS8	73050	1.0	HSTSS	61173
4	V-Tip			HSA200	73489	0.5	HVT8-S/S	75419
							HVPT-S/S	73631
SIDE MOUNTING ASSEMBLY COMPONENTS- TO SUIT 60 mm								
5	H Mounting Bracket			HDMRK	74582	2.0	HDMRK-S/S	76245
6	H Bearing			HBRK	73068	1.5	HBRK-S/S	75422
6a	H Poly Bush 60mm			UNB60	61369	0.1		
6b	H Poly Bush 73mm			UNB73	A2671	0.1		
7	H Adjusting Arm			HARK	73069	1.5	HARK-S/S	75423
8	J-Bolt			STJK	74417	1.0		
9	Tension Spring			STTS	74419	1.0		
10	Spring Tensioner Collar			STCK	74506	1.0	STCK-S/S	75425
11	Spring Tensioner J-Bolt Mount			STJM	74775	1.0	STJM-S/S	75426
-	Spring Tension Kit-Dual (incl. STJK, STTS, STCK, STJM - 2 ea.)			STKD	74504	5.0	STKD-S/S	75427
-	H Mounting Kit- Dual (incl. HDMRK, HBRK, HARK - 2 ea.)			HMK	73054	11.0	HMK-S/S	75424
-	Black Compression Spring Side Assembly 60mm			HCSTK-60-B	62747	11.0	HCSTK-60-B-S/S	62748
-	Gold Compression Spring Side Assembly 60mm			HCSTK-60-G	62741	11.0	HCSTK-60-G-S/S	62742
SIDE MOUNTING ASSEMBLY COMPONENTS- TO SUIT 73 mm								
5	H Mounting Bracket			HDMRK	74582	3.0	HDMRK-S/S	76245
6	H Bearing			HBRKX	74549	2.0	HBRKX-S/S	76246
7	H Adjusting Arm			HDARK	74550	2.0	HDARK-S/S	76247
8	J-Bolt			STJK	74417	1.0		
9	Tension Spring			UTS	74420	1.0		
10	Spring Tensioner Collar			HDCK	74490	1.0	HDSTCK-S/S	A2189
11	Spring Tensioner J-Bolt Mount			STJM	74775	1.0	STJM-S/S	75426
-	Spring Tension Kit-Dual (incl. STJK, UTS, HDCK, STJM - 2 ea.)			HDSTKD	A2518	5.0	HDSTKD-S/S	A2519
-	H Mounting Kit- Dual (incl. HDMRK, HBRKX, HDARK - 2 ea.)			HDMK	74551	14.0	HDMK-S/S	76248
-	Black Compression Spring Side Assembly (to 1600 belt width max)			H73CSK-B	62749	17.8	H73CSK-B-S/S	62750
-	Gold Compression Spring Side Assembly (to 2400 belt width max)			H73CSK-G	62743	17.8	H73CSK-G-S/S	62744

Product Ordering Information

H-Type ESAC (Mild Steel) HD Primary Cleaner with Enhanced Service Advantage Cartridge™

Powder Coated H-Type® ESAC with V-Tips

TIP WIDTH	ARM SIZE	ORDERING NUMBER	ITEM CODE	Wght. KG.
Single Cartridge				
600	CS	HV-600-SAC-CS	62515	74.2
	CM	HV-600-SAC-CM	62516	74.9
	CL	HV-600-SAC-CL	62517	75.3
800	CS	HV-800-SAC-CS	62518	86.5
	CM	HV-800-SAC-CM	62519	87.5
	CL	HV-800-SAC-CL	62520	88.1
1000	CS	HV-1000-SAC-CS	62521	94.9
	CM	HV-1000-SAC-CM	62522	96.2
	CL	HV-1000-SAC-CL	62523	96.9
1200	CS	HV-1200-SAC-CS	62524	103.3
	CM	HV-1200-SAC-CM	62525	104.7
	CL	HV-1200-SAC-CL	62526	105.6
1400	CS	HV-1400-SAC-CS	62527	115.9
	CM	HV-1400-SAC-CM	62528	117.5
	CL	HV-1400-SAC-CL	62529	118.6
1600	CM	HV-1600-SAC-CM	62530	130.0
	CL	HV-1600-SAC-CL	62531	131.3
	CLL	HV-1600-SAC-CLL	62532	135.2
1800	CM	HV-1800-SAC-CM	62533	137.2
	CL	HV-1800-SAC-CL	62534	138.5
	CLL	HV-1800-SAC-CLL	62535	142.8
Dual Cartridge				
1200	CS	HV-1200-2SAC-CS	62557	128.7
	CM	HV-1200-2SAC-CM	62558	130.3
	CL	HV-1200-2SAC-CL	62559	131.2
	CLL	HV-1200-2SAC-CLL	62560	134.1
1400	CS	HV-1400-2SAC-CS	62561	137.4
	CM	HV-1400-2SAC-CM	62562	139.0
	CL	HV-1400-2SAC-CL	62563	140.1
	CLL	HV-1400-2SAC-CLL	62564	143.4
1600	CM	HV-1600-2SAC-CM	62565	147.9
	CL	HV-1600-2SAC-CL	62566	149.1
	CLL	HV-1600-2SAC-CLL	62567	152.9
1800	CM	HV-1800-2SAC-CM	62568	159.5
	CL	HV-1800-2SAC-CL	62569	160.9
	CLL	HV-1800-2SAC-CLL	62570	163.8
2000	CM	HV-2000-2SAC-CM	62571	169.2
	CL	HV-2000-2SAC-CL	62572	170.7
	CLL	HV-2000-2SAC-CLL	62573	174.0
2200	CM	HV-2200-2SAC-CM	62574	182.4
	CL	HV-2200-2SAC-CL	62575	184.1
	CLL	HV-2200-2SAC-CLL	62576	187.7
2400	CM	HV-2400-2SAC-CM	62577	187.5
	CL	HV-2400-2SAC-CL	62578	189.3
	CLL	HV-2400-2SAC-CLL	62579	193.3
2600	CM	HV-2600-2SAC-CM	62580	211.2
	CL	HV-2600-2SAC-CL	62581	213.2
	CLL	HV-2600-2SAC-CLL	62582	217.4
2800	CM	HV-2800-2SAC-CM	62583	220.9
	CL	HV-2800-2SAC-CL	62584	223.0
	CLL	HV-2800-2SAC-CLL	62585	227.7
3000	CM	HV-3000-2SAC-CM	62586	230.0
	CL	HV-3000-2SAC-CL	62587	232.3
	CLL	HV-3000-2SAC-CLL	62588	237.2

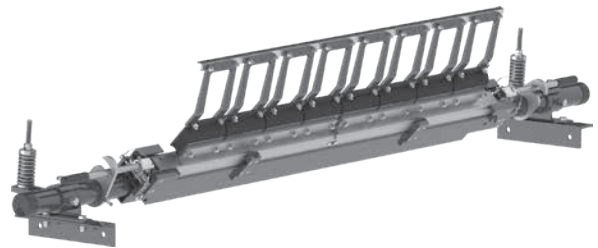

H-Type ESAC Dual HD Primary Cleaner

Replacement V-Tips

ORDERING NUMBER	ITEM CODE	WT. KG.
HSA200	73489	0.5

Replacement Suspension Arms

SIZE	ORDERING NUMBER	ITEM CODE	WT. KG.
CS	HSA8CS	62505	1.1
CM	HSA8CM	62506	1.3
CL	HSA8CL	62507	1.5
CLL	HSA8CLL	62508	1.7

Suspension Arm Size

HEAD PULLEY DIAMETER + BELT & LAGGING mm	SUSPENSION ARM SIZE
500-799	CS
800-999	CM
1000-1199	CL
1200-1700	CLL

Over 1700mm - contact Flexco

Tips required per cleaner size

BELT WIDTH mm	BELT COVERAGE mm	V-TIPS REQUIRED
600	600	3
800	800	4
1000	1000	5
1200	1200	6
1400	1400	7
1600	1600	8
1800	1800	9
2000	2000	10
2200	2200	11
2400	2400	12
2600	2600	13
2800	2800	14
3000	3000	15

Stock items (non-shaded) refer to (*) for specific lead time, if not specified, standard lead time applies.

Non-stock items (shaded) please contact Flexco for dispatch options and lead times.

Product Ordering Information

H-Type ESAC (Mild Steel) HD Primary Cleaner with Enhanced Service Advantage Cartridge™

H-Type ESAC Mild Steel Replacement Cartridge Kits with V-Tips

TIP WIDTH	ARM SIZE	ORDERING NUMBER	ITEM CODE	Wght. KG.
Single Cartridge Kits				
600	CS	H-CARK-600-CS	62536	23.2
	CM	H-CARK-600-CM	62537	24.0
	CL	H-CARK-600-CL	62538	24.5
800	CS	H-CARK-800-CS	62539	30.3
	CM	H-CARK-800-CM	62540	31.3
	CL	H-CARK-800-CL	62541	31.9
1000	CS	H-CARK-1000-CS	62542	36.1
	CM	H-CARK-1000-CM	62543	37.4
	CL	H-CARK-1000-CL	62544	38.2
1200	CS	H-CARK-1200-CS	62545	41.4
	CM	H-CARK-1200-CM	62546	43.3
	CL	H-CARK-1200-CL	62547	44.2
1400	CS	H-CARK-1400-CS	62548	49.0
	CM	H-CARK-1400-CM	62549	50.8
	CL	H-CARK-1400-CL	62550	51.9
1600	CM	H-CARK-1600-CS	62551	58.1
	CL	H-CARK-1600-CM	62552	59.3
	CLL	H-CARK-1600-CL	62553	63.1
1800	CM	H-CARK-1800-CS	62554	66.2
	CL	H-CARK-1800-CM	62555	67.6
	CLL	H-CARK-1800-CL	62556	71.9
Dual Cartridge Kits				
1200	CS	H-CARK2-1200-CS	62599	46.2
	CM	H-CARK2-1200-CM	62600	47.8
	CL	H-CARK2-1200-CL	62601	48.7
	CLL	H-CARK2-1200-CLL	62602	51.6
1400	CS	H-CARK2-1400-CS	62603	51.8
	CM	H-CARK2-1400-CM	62604	53.6
	CL	H-CARK2-1400-CL	62605	54.6
	CLL	H-CARK2-1400-CLL	62606	58.0
1600	CM	H-CARK2-1600-CM	62607	59.4
	CL	H-CARK2-1600-CL	62608	60.6
	CLL	H-CARK2-1600-CLL	62609	64.4
1800	CM	H-CARK2-1800-CM	62610	68.1
	CL	H-CARK2-1800-CL	62611	69.4
	CLL	H-CARK2-1800-CLL	62612	73.8
2000	CM	H-CARK2-2000-CM	62613	74.8
	CL	H-CARK2-2000-CL	62614	76.3
	CLL	H-CARK2-2000-CLL	62615	81.1
2200	CM	H-CARK2-2200-CM	62616	82.1
	CL	H-CARK2-2200-CL	62617	83.7
	CLL	H-CARK2-2200-CLL	62618	89.0
2400	CM	H-CARK2-2400-CM	62619	87.1
	CL	H-CARK2-2400-CL	62620	88.9
	CLL	H-CARK2-2400-CLL	62621	94.7
2600	CM	H-CARK2-2600-CM	62622	95.7
	CL	H-CARK2-2600-CL	62623	97.7
	CLL	H-CARK2-2600-CLL	62624	103.9
2800	CM	H-CARK2-2800-CM	62625	102.2
	CL	H-CARK2-2800-CL	62626	104.3
	CLL	H-CARK2-2800-CLL	62627	111.0
3000	CM	H-CARK2-3000-CM	62628	107.7
	CL	H-CARK2-3000-CL	62629	110.0
	CLL	H-CARK2-3000-CLL	62630	117.2

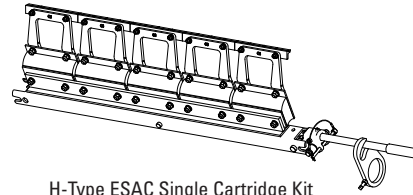

H-Type ESAC Single Cartridge Kit

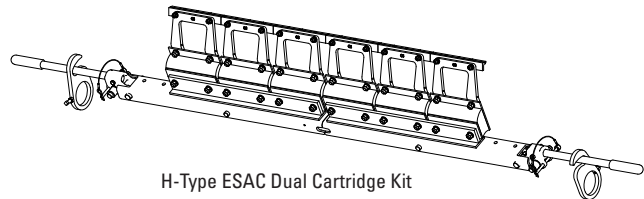

H-Type ESAC Dual Cartridge Kit

Stock items (non-shaded) refer to (*) for specific lead time, if not specified, standard lead time applies.

Non-stock items (shaded) please contact Flexco for dispatch options and lead times.

Product Ordering Information

H-Type ESAC (Stainless Steel) HD Primary Cleaner with Enhanced Service Advantage Cartridge™

Stainless Steel H-Type® ESAC with V-Tips

TIP WIDTH	ARM SIZE	ORDERING NUMBER	ITEM CODE	Wght. KG.
Single Cartridge				
600	CS	HV-600-SAC-CS-S/S	62631	74.2
	CM	HV-600-SAC-CM-S/S	62632	74.9
	CL	HV-600-SAC-CL-S/S	62633	75.3
800	CS	HV-800-SAC-CS-S/S	62634	86.5
	CM	HV-800-SAC-CM-S/S	62635	87.5
	CL	HV-800-SAC-CL-S/S	62636	88.1
1000	CS	HV-1000-SAC-CS-S/S	62637	94.9
	CM	HV-1000-SAC-CM-S/S	62638	96.2
	CL	HV-1000-SAC-CL-S/S	62639	96.9
1200	CS	HV-1200-SAC-CS-S/S	62640	103.3
	CM	HV-1200-SAC-CM-S/S	62641	104.7
	CL	HV-1200-SAC-CL-S/S	62642	105.6
1400	CS	HV-1400-SAC-CS-S/S	62643	115.9
	CM	HV-1400-SAC-CM-S/S	62644	117.5
	CL	HV-1400-SAC-CL-S/S	62645	118.6
1600	CM	HV-1600-SAC-CM-S/S	62646	130.0
	CL	HV-1600-SAC-CL-S/S	62647	131.3
	CLL	HV-1600-SAC-CLL-S/S	62648	135.2
1800	CM	HV-1800-SAC-CM-S/S	62649	137.2
	CL	HV-1800-SAC-CL-S/S	62650	138.5
	CLL	HV-1800-SAC-CLL-S/S	62651	142.8
Dual Cartridge				
1200	CS	HV-1200-2SAC-CS-S/S	62673	128.7
	CM	HV-1200-2SAC-CM-S/S	62674	130.3
	CL	HV-1200-2SAC-CL-S/S	62675	131.2
	CLL	HV-1200-2SAC-CLL-S/S	62676	134.1
1400	CS	HV-1400-2SAC-CS-S/S	62677	137.4
	CM	HV-1400-2SAC-CM-S/S	62678	139.0
	CL	HV-1400-2SAC-CL-S/S	62679	140.1
	CLL	HV-1400-2SAC-CLL-S/S	62680	143.4
1600	CM	HV-1600-2SAC-CM-S/S	62681	147.9
	CL	HV-1600-2SAC-CL-S/S	62582	160.9
	CLL	HV-1600-2SAC-CLL-S/S	62683	152.9
1800	CM	HV-1800-2SAC-CM-S/S	62684	159.5
	CL	HV-1800-2SAC-CL-S/S	62685	160.9
	CLL	HV-1800-2SAC-CLL-S/S	62686	163.8
2000	CM	HV-2000-2SAC-CM-S/S	62687	169.2
	CL	HV-2000-2SAC-CL-S/S	62688	170.7
	CLL	HV-2000-2SAC-CLL-S/S	62689	174.0
2200	CM	HV-2200-2SAC-CM-S/S	62690	182.4
	CL	HV-2200-2SAC-CL-S/S	62691	184.1
	CLL	HV-2200-2SAC-CLL-S/S	62692	187.7
2400	CM	HV-2400-2SAC-CM-S/S	62693	187.5
	CL	HV-2400-2SAC-CL-S/S	62694	189.3
	CLL	HV-2400-2SAC-CLL-S/S	62695	193.3
2600	CM	HV-2600-2SAC-CM-S/S	62696	211.2
	CL	HV-2600-2SAC-CL-S/S	62697	213.2
	CLL	HV-2600-2SAC-CLL-S/S	62698	217.4
2800	CM	HV-2800-2SAC-CM-S/S	62699	220.9
	CL	HV-2800-2SAC-CL-S/S	62700	223.0
	CLL	HV-2800-2SAC-CLL-S/S	62701	227.7
3000	CM	HV-3000-2SAC-CM-S/S	62702	230.0
	CL	HV-3000-2SAC-CL-S/S	62703	232.3
	CLL	HV-3000-2SAC-CLL-S/S	62704	237.2

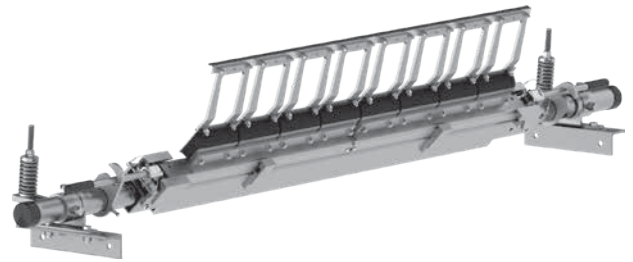

Stainless Steel H-Type ESAC Dual HD Primary Cleaner

Replacement V-Tips

ORDERING NUMBER	ITEM CODE	WT. KG.
HVT8-S/S	75419	0.9
HVPT-S/S	73631	1.2

Replacement Suspension Arms SS

SIZE	ORDERING NUMBER	ITEM CODE	WT. KG.
CS	HSA8CS-S/S	62509	1.1
CM	HSA8CM-S/S	62510	1.3
CL	HSA8CL-S/S	62511	1.5
CLL	HSA8CLL-S/S	62512	1.7

Suspension Arm Size

HEAD PULLEY DIAMETER + BELT & LAGGING mm	SUSPENSION ARM SIZE
500-799	CS
800-999	CM
1000-1199	CL
1200-1700	CLL

Over 1700mm - contact Flexco

Tips required per cleaner size

BELT WIDTH mm	BELT COVERAGE mm	V-TIPS REQUIRED
600	600	3
800	800	4
1000	1000	5
1200	1200	6
1400	1400	7
1600	1600	8
1800	1800	9
2000	2000	10
2200	2200	11
2400	2400	12
2600	2600	13
2800	2800	14
3000	3000	15

Stock items (non-shaded) refer to (*) for specific lead time, if not specified, standard lead time applies.

Non-stock items (shaded) please contact Flexco for dispatch options and lead times.

Product Ordering Information

H-Type ESAC (Stainless Steel) HD Primary Cleaner with Enhanced Service Advantage Cartridge™

H-Type ESAC Stainless Steel Replacement Cartridge Kits with V-Tips

TIP WIDTH	ARM SIZE	ORDERING NUMBER	ITEM CODE	Wght. KG.
Single Cartridge Kits				
600	CS	H CARK-600-CS-S/S	62652	23.2
	CM	H CARK-600-CM-S/S	62653	24.0
	CL	H CARK-600-CL-S/S	62654	24.5
800	CS	H CARK-800-CS-S/S	62655	30.3
	CM	H CARK-800-CM-S/S	62656	31.3
	CL	H CARK-800-CL-S/S	62657	31.9
1000	CS	H CARK-1000-CS-S/S	62658	36.1
	CM	H CARK-1000-CM-S/S	62659	37.4
	CL	H CARK-1000-CL-S/S	62660	38.2
1200	CS	H CARK-1200-CS-S/S	62661	41.4
	CM	H CARK-1200-CM-S/S	62662	43.3
	CL	H CARK-1200-CL-S/S	62663	44.2
1400	CS	H CARK-1400-CS-S/S	62664	49.0
	CM	H CARK-1400-CM-S/S	62665	50.8
	CL	H CARK-1400-CL-S/S	62666	51.9
1600	CM	H CARK-1600-CS-S/S	62667	58.1
	CL	H CARK-1600-CM-S/S	62668	59.3
	CLL	H CARK-1600-CL-S/S	62669	63.1
1800	CM	H CARK-1800-CS-S/S	62670	66.2
	CL	H CARK-1800-CM-S/S	62671	67.6
	CLL	H CARK-1800-CL-S/S	62672	71.9
Dual Cartridge Kits				
1200	CS	H-CARK2-1200-CS-S/S	62705	46.2
	CM	H-CARK2-1200-CM-S/S	62706	47.8
	CL	H-CARK2-1200-CL-S/S	62707	48.7
	CLL	H-CARK2-1200-CLL-S/S	62708	51.6
1400	CS	H-CARK2-1400-CS-S/S	62709	51.8
	CM	H-CARK2-1400-CM-S/S	62710	53.6
	CL	H-CARK2-1400-CL-S/S	62711	54.6
	CLL	H-CARK2-1400-CLL-S/S	62712	58.0
1600	CM	H-CARK2-1600-CM-S/S	62713	59.4
	CL	H-CARK2-1600-CL-S/S	62714	60.6
	CLL	H-CARK2-1600-CLL-S/S	62715	64.4
1800	CM	H-CARK2-1800-CM-S/S	62716	68.1
	CL	H-CARK2-1800-CL-S/S	62717	69.4
	CLL	H-CARK2-1800-CLL-S/S	62718	73.8
2000	CM	H-CARK2-2000-CM-S/S	62719	74.8
	CL	H-CARK2-2000-CL-S/S	62720	76.3
	CLL	H-CARK2-2000-CLL-S/S	62721	81.1
2200	CM	H-CARK2-2200-CM-S/S	62722	82.1
	CL	H-CARK2-2200-CL-S/S	62723	83.7
	CLL	H-CARK2-2200-CLL-S/S	62724	89.0
2400	CM	H-CARK2-2400-CM-S/S	62725	87.1
	CL	H-CARK2-2400-CL-S/S	62726	88.9
	CLL	H-CARK2-2400-CLL-S/S	62727	94.7
2600	CM	H-CARK2-2600-CM-S/S	62728	95.7
	CL	H-CARK2-2600-CL-S/S	62729	97.7
	CLL	H-CARK2-2600-CLL-S/S	62730	103.9
2800	CM	H-CARK2-2800-CM-S/S	62731	102.2
	CL	H-CARK2-2800-CL-S/S	62732	104.3
	CLL	H-CARK2-2800-CLL-S/S	62733	111.0
3000	CM	H-CARK2-3000-CM-S/S	62734	107.7
	CL	H-CARK2-3000-CL-S/S	62735	110.0
	CLL	H-CARK2-3000-CLL-S/S	62736	117.2

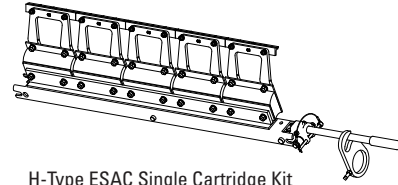

H-Type ESAC Single Cartridge Kit

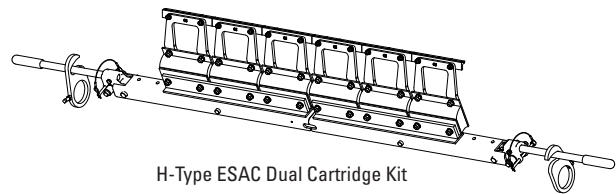

H-Type ESAC Dual Cartridge Kit

Stock items (non-shaded) refer to (*) for specific lead time, if not specified, standard lead time applies.

Non-stock items (shaded) please contact Flexco for dispatch options and lead times.

Replacement Parts List

H-Type ESAC Single HD Primary Cleaner with Enhanced Service Advantage Cartridge™

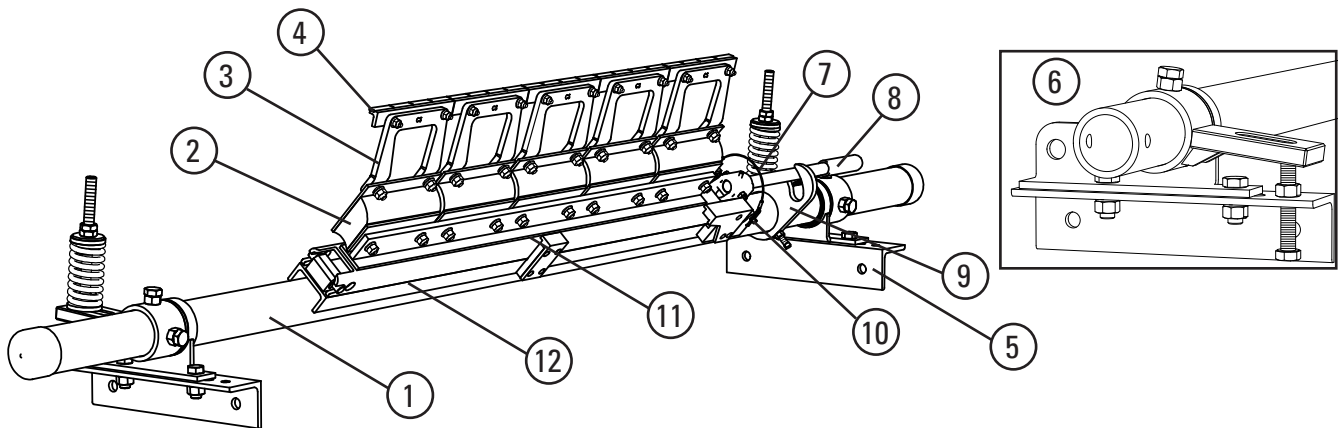

REPLACEMENT PARTS

REF	DESCRIPTION	MILD STEEL			STAINLESS STEEL		
		ORDERING NUMBER	ITEM CODE	WT. KG.	ORDERING NUMBER	ITEM CODE	WT. KG.
1	H-Type Single ESAC Cartridge Pole	HCP-600	62751	30.5	HCP-600-S/S	62757	31.4
		HCP-800	62752	35.6	HCP-800-S/S	62758	36.7
		HCP-1000	62753	38.1	HCP-1000-S/S	62759	39.3
		HCP-1200	62754	40.7	HCP-1200-S/S	62760	42
		HCP-1400	62755	45.9	HCP-1400-S/S	62761	47.3
		HCP-1800	62756	51.0	HCP-1800-S/S	62762	52.6
2	HD Cushion	HSHD	73483	2.0	HSHD-S/S	76467	2
3	Suspension Arm	HSA8CS	62505	0.9	HSA8CS-S/S	62509	1
		HSA8CM	62506	1.1	HSA8CM-S/S	62510	1.2
		HSA8CL	62507	1.3	HSA8CL-S/S	62511	1.3
		HSA8CLL	62508	1.8	HSA8CLL-S/S	62512	1.8
4	HV Tips	HSA200	73489	0.5	HVT8-S/S	75419	0.6
	HVPT Tips	-	-	-	HVPT-S/S	73631	0.6
5	Black Compression Spring Side Assembly (to 1600 belt width max)	H73CSK-B	62749	17.8	H73CSK-B-S/S	62750	18.3
	Gold Compression Spring Side Assembly (to 2400 belt width max)	H73CSK-G	62743	17.8	H73CSK-G-S/S	62744	18.3
6	Bolt Tension Side Assembly	H73BTK	63079	15.1	H73BTK-S/S	63080	15.6
7	SAC Removal Knuckle	SACRKN	77882	1.5			
8	SAC Removal Handle	SACRH	77883	1.4			
9	SAC Handle Lock Plate	SACRHL	77884	0.8			
10	Knuckle Retainer Pin	SACKRP	77885	0.1			
REF	DESCRIPTION	TIP WIDTH	ORDERING NUMBER	ITEM CODE	WT. KG.		
11	H-Type Cartridge Adapter Plate	600	H-SAC-AP-600	62452	3.5		
		800	H-SAC-AP-800	62453	4.8		
		1000	H-SAC-AP-1000	62454	6.0		
		1200	H-SAC-AP-1200	62455	7.3		
		1400	H-SAC-AP-1400	62456	8.5		
		1600	H-SAC-AP-1600	62457	9.8		
12	SAC Replacement Single Cartridge	600	CART-24/600-S/S	78576	4.5		
		800	CART-36/900-S/S	78578	6.7		
		1000	CART-42/1050-S/S	78579	7.8		
		1200	CART2-48/1200-S/S	78580	8.9		
		1400	CART-60/1500-S/S	78582	11.3		
		1600	CART-72/1800-S/S	78583	13.5		
		1800					

HV/HVP Single SAC Black Spring Length Chart (for optimal blade tensioning)

Belt Width	CS	CM	CL	CLL
600	111	110	109	107
800	109	107	107	104
1000	106	105	104	100
1200	104	102	101	97
1400	102	100	98	93
1600	100	97	96	90
1800	97	95	93	-

HV/HVP Single SAC Gold Spring Length Chart (for optimal blade tensioning)

Belt Width	CS	CM	CL	CLL
600	113	113	112	111
800	112	111	111	109
1000	111	110	109	107
1200	109	108	107	105
1400	108	106	106	102
1600	106	105	104	100
1800	105	103	102	98

HV/HVP Dual SAC Gold Spring Length Chart (for optimal blade tensioning)

Belt Width	CS	CM	CL	CLL
1200	109	108	108	105
1400	108	107	106	103
1600	107	105	104	101
1800	105	104	103	99
2000	104	102	101	96
2200	103	101	99	94

HV/HVP Dual SAC Silver Spring Length Chart (for optimal blade tensioning)

Belt Width	CS	CM	CL	CLL
2200	159	158	157	154
2400	158	157	156	153
2600	157	156	155	151
2800	157	155	154	150
3000	156	154	153	149

Stock items (non-shaded) refer to (*) for specific lead time, if not specified, standard lead time applies.

Non-stock items (shaded) please contact Flexco for dispatch options and lead times.

Replacement Parts List

H-Type ESAC Dual HD Primary Cleaner with Enhanced Service Advantage Cartridge™

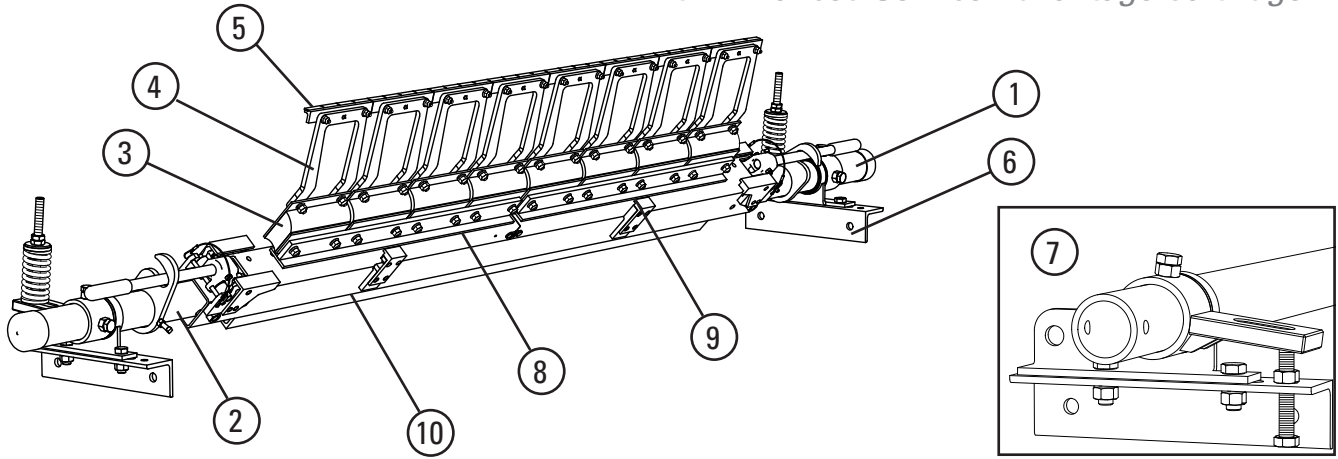

REPLACEMENT PARTS

REF	DESCRIPTION	MILD STEEL			STAINLESS STEEL			
		ORDERING NUMBER	ITEM CODE	WT. KG.	ORDERING NUMBER	ITEM CODE	WT. KG.	
1	H-Type Dual ESAC Centre Pole	H2CP-1200	62763	39.7	H2CP-1200-S/S	62801	39.7	
		H2CP-1400	62764	42.6	H2CP-1400-S/S	62802	42.6	
		H2CP-1600	62765	45.7	H2CP-1600-S/S	62803	45.7	
		H2CP-1800	62766	48.6	H2CP-1800-S/S	62804	48.6	
		H2CP-2000	62767	51.6	H2CP-2000-S/S	62805	51.6	
		H2CP-2400	62768	57.6	H2CP-2400-S/S	62806	57.6	
		H2CP-2600	62769	71.0	H2CP-2600-S/S	62807	71.0	
		H2CP-2800	62770	74.3	H2CP-2800-S/S	62808	74.3	
	H2CP-3000	62771	77.8	H2CP-3000-S/S	62809	77.8		
2	Extender Pole	MHP-EP	76392	24.5	MHP-EP-S/S	77599	24.5	
3	HD Cushion	HSHD	73483	2.0	HSHD-S/S	76467	2.0	
4	Suspension Arm	HSA8CS	62505	0.9	HSA8CS-S/S	62509	1.0	
		HSA8CM	62506	1.1	HSA8CM-S/S	62510	1.2	
		HSA8CL	62507	1.3	HSA8CL-S/S	62511	1.3	
		HSA8CLL	62508	1.8	HSA8CLL-S/S	62512	1.8	
5	HV Tips	HSA200	73489	0.5	HVT8-S/S	75419	0.6	
	HVPT Tips	-	-	-	HVPT-S/S	73631	0.6	
6	Black Compression Spring Side Assembly (to 1600 belt width max)	H73CSK-B	62749	17.8	H73CSK-B-S/S	62750	18.3	
	Gold Compression Spring Side Assembly (to 2400 belt width max)	H73CSK-G	62743	17.8	H73CSK-G-S/S	62744	18.3	
	Silver 6" Compression Spring Side Assembly (above 2400)	H73CSK-S	62745	18.0	H73CSK-S-S/S	62746	18.4	
7	Bolt Tension Side Assembly	H73BTK	63079	15.1	H73BTK-S/S	63080	15.6	
REF	DESCRIPTION	TIP WIDTH	ITEM 8 / LEFT HAND			ITEM 9 / RIGHT HAND		
			ORDERING NUMBER	ITEM CODE	WT. KG.	ORDERING NUMBER	ITEM CODE	WT. KG.
8 & 9	H-Type Cartridge Adapter Plate	1200	H-SAC-AP-600	62452	3.5	H-SAC-AP-600	62452	3.5
		1400	H-SAC-AP-800	62453	4.8	H-SAC-AP-600	62452	3.5
		1600	H-SAC-AP-800	62453	4.8	H-SAC-AP-800	62453	4.8
		1800	H-SAC-AP-1000	62454	6.0	H-SAC-AP-800	62453	4.8
		2000	H-SAC-AP-1000	62454	6.0	H-SAC-AP-1000	62454	6.0
		2200	H-SAC-AP-1200	62455	7.3	H-SAC-AP-1000	62454	6.0
		2400	H-SAC-AP-1200	62455	7.3	H-SAC-AP-1200	62455	7.3
		2600	H-SAC-AP-1400	62456	8.5	H-SAC-AP-1200	62455	7.3
		2800	H-SAC-AP-1400	62456	8.5	H-SAC-AP-1400	62456	8.5
		3000	H-SAC-AP-1600	62457	9.8	H-SAC-AP-1400	62456	8.5
REF	DESCRIPTION	TIP WIDTH	ORDERING NUMBER	ITEM CODE	WT. KG.			
10	SAC Replacement Dual Cartridge	1200	CART2-60/1500-S/S	78584	11.2			
		1400	CART2-66/1650-S/S	78634	12.3			
		1600	CART2-72/1800-S/S	78585	13.4			
		1800	CART2-78/1950-S/S	78635	14.5			
		2000	CART2-84/2100-S/S	78586	15.6			
		2200	CART2-96/2400-S/S	78587	17.8			
		2400						
		2600	CART2-114/2850-S/S	78639	23.7			
		2800	CART2-120/3000-S/S	78588	22.6			
		3000	CART2-126/3150-S/S	78640	23.7			

Product Ordering Information

H-Type ESAC with Extra Life V-Tips (Mild Steel) HD Primary Cleaner with Enhanced Service Advantage Cartridge™

Powder Coated H-Type® ESAC with Extra Life V-Tips

TIP WIDTH	ARM SIZE	ORDERING NUMBER	ITEM CODE	Wght. KG.
Single Cartridge				
600	CS	HV-600-SAC-CS-EL15	63206	74.2
	CM	HV-600-SAC-CM-EL15	63207	74.9
	CL	HV-600-SAC-CL-EL15	63208	75.3
800	CS	HV-800-SAC-CS-EL15	63209	86.5
	CM	HV-800-SAC-CM-EL15	63210	87.5
	CL	HV-800-SAC-CL-EL15	63211	88.1
1000	CS	HV-1000-SAC-CS-EL15	63212	94.9
	CM	HV-1000-SAC-CM-EL15	63213	96.2
	CL	HV-1000-SAC-CL-EL15	63214	96.9
1200	CS	HV-1200-SAC-CS-EL15	63215	103.3
	CM	HV-1200-SAC-CM-EL15	63216	104.7
	CL	HV-1200-SAC-CL-EL15	63217	105.6
1400	CS	HV-1400-SAC-CS-EL15	63218	115.9
	CM	HV-1400-SAC-CM-EL15	63219	117.5
	CL	HV-1400-SAC-CL-EL15	63220	118.6
1600	CM	HV-1600-SAC-CM-EL15	63221	130.0
	CL	HV-1600-SAC-CL-EL15	63222	131.3
	CLL	HV-1600-SAC-CLL-EL15	63223	135.2
1800	CM	HV-1800-SAC-CM-EL15	63224	137.2
	CL	HV-1800-SAC-CL-EL15	63225	138.5
	CLL	HV-1800-SAC-CLL-EL15	63226	142.8
Dual Cartridge				
1200	CS	HV-1200-2SAC-CS-EL15	63421	128.7
	CM	HV-1200-2SAC-CM-EL15	63422	130.3
	CL	HV-1200-2SAC-CL-EL15	63423	131.2
	CLL	HV-1200-2SAC-CLL-EL15	63424	134.1
1400	CS	HV-1400-2SAC-CS-EL15	63425	137.4
	CM	HV-1400-2SAC-CM-EL15	63426	139.0
	CL	HV-1400-2SAC-CL-EL15	63427	140.1
	CLL	HV-1400-2SAC-CLL-EL15	63428	143.4
1600	CM	HV-1600-2SAC-CM-EL15	63429	147.9
	CL	HV-1600-2SAC-CL-EL15	63430	149.1
	CLL	HV-1600-2SAC-CLL-EL15	63431	152.9
1800	CM	HV-1800-2SAC-CM-EL15	63432	159.5
	CL	HV-1800-2SAC-CL-EL15	63433	160.9
	CLL	HV-1800-2SAC-CLL-EL15	63434	163.8
2000	CM	HV-2000-2SAC-CM-EL15	63435	169.2
	CL	HV-2000-2SAC-CL-EL15	63436	170.7
	CLL	HV-2000-2SAC-CLL-EL15	63437	174.0
2200	CM	HV-2200-2SAC-CM-EL15	63438	182.4
	CL	HV-2200-2SAC-CL-EL15	63439	184.1
	CLL	HV-2200-2SAC-CLL-EL15	63440	187.7
2400	CM	HV-2400-2SAC-CM-EL15	63441	187.5
	CL	HV-2400-2SAC-CL-EL15	63442	189.3
	CLL	HV-2400-2SAC-CLL-EL15	63443	193.3
2600	CM	HV-2600-2SAC-CM-EL15	63444	211.2
	CL	HV-2600-2SAC-CL-EL15	63445	213.2
	CLL	HV-2600-2SAC-CLL-EL15	63446	217.4
2800	CM	HV-2800-2SAC-CM-EL15	63447	220.9
	CL	HV-2800-2SAC-CL-EL15	63448	223.0
	CLL	HV-2800-2SAC-CLL-EL15	63449	227.7
3000	CM	HV-3000-2SAC-CM-EL15	63450	230.0
	CL	HV-3000-2SAC-CL-EL15	63451	232.3
	CLL	HV-3000-2SAC-CLL-EL15	63452	237.2

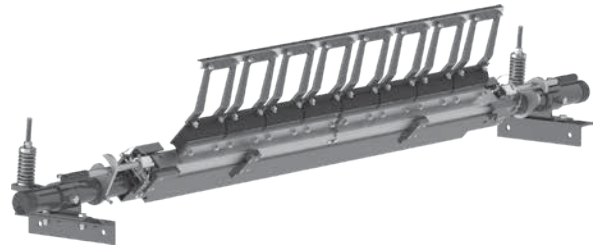

H-Type ESAC Dual HD Primary Cleaner

Replacement V-Tips

ORDERING NUMBER	ITEM CODE	WT. KG.
HSA200	73489	0.5
HSA200-EL15	76027	0.6

Replacement Suspension Arms

SIZE	ORDERING NUMBER	ITEM CODE	WT. KG.
CS	HSA8CS	62505	1.1
CM	HSA8CM	62506	1.3
CL	HSA8CL	62507	1.5
CLL	HSA8CLL	62508	1.7

Suspension Arm Size

HEAD PULLEY DIAMETER + BELT & LAGGING mm	SUSPENSION ARM SIZE
500-799	CS
800-999	CM
1000-1199	CL
1200-1700	CLL

Over 1700mm - contact Flexco

Tips required per cleaner size

BELT WIDTH mm	BELT COVERAGE mm	V-TIPS REQUIRED
600	600	3
800	800	4
1000	1000	5
1200	1200	6
1400	1400	7
1600	1600	8
1800	1800	9
2000	2000	10
2200	2200	11
2400	2400	12
2600	2600	13
2800	2800	14
3000	3000	15

Stock items (non-shaded) refer to (*) for specific lead time, if not specified, standard lead time applies.

Non-stock items (shaded) please contact Flexco for dispatch options and lead times.

Product Ordering Information

H-Type ESAC with Extra Life V-Tips (Mild Steel) HD Primary Cleaner with Enhanced Service Advantage Cartridge™

H-Type ESAC Mild Steel Replacement Cartridge Kits with Extra Life V-Tips

TIP WIDTH	ARM SIZE	ORDERING NUMBER	ITEM CODE	Wght. KG.
Single Cartridge Kits				
600	CS	H-CARK-600-CS-EL15	63631	23.2
	CM	H-CARK-600-CM-EL15	63632	24
	CL	H-CARK-600-CL-EL15	63633	24.5
800	CS	H-CARK-800-CS-EL15	63634	30.3
	CM	H-CARK-800-CM-EL15	63635	31.3
	CL	H-CARK-800-CL-EL15	63636	31.9
1000	CS	H-CARK-1000-CS-EL15	63637	36.1
	CM	H-CARK-1000-CM-EL15	63638	37.4
	CL	H-CARK-1000-CL-EL15	63639	38.2
1200	CS	H-CARK-1200-CS-EL15	63640	41.4
	CM	H-CARK-1200-CM-EL15	63641	43.3
	CL	H-CARK-1200-CL-EL15	63642	44.2
1400	CS	H-CARK-1400-CS-EL15	63643	49
	CM	H-CARK-1400-CM-EL15	63644	50.8
	CL	H-CARK-1400-CL-EL15	63645	51.9
1600	CM	H-CARK-1600-CS-EL15	63646	58.1
	CL	H-CARK-1600-CM-EL15	63647	59.3
	CLL	H-CARK-1600-CL-EL15	63648	63.1
1800	CM	H-CARK-1800-CS-EL15	63649	66.2
	CL	H-CARK-1800-CM-EL15	63650	67.6
	CLL	H-CARK-1800-CL-EL15	63651	71.9
Dual Cartridge Kits				
1200	CS	H-CARK2-1200-CS-EL15	63567	46.2
	CM	H-CARK2-1200-CM-EL15	63568	47.8
	CL	H-CARK2-1200-CL-EL15	63569	48.7
	CLL	H-CARK2-1200-CLL-EL15	63570	51.6
1400	CS	H-CARK2-1400-CS-EL15	63571	51.8
	CM	H-CARK2-1400-CM-EL15	63572	53.6
	CL	H-CARK2-1400-CL-EL15	63573	54.6
	CLL	H-CARK2-1400-CLL-EL15	63574	58
1600	CM	H-CARK2-1600-CM-EL15	63575	59.4
	CL	H-CARK2-1600-CL-EL15	63576	60.6
	CLL	H-CARK2-1600-CLL-EL15	63577	64.4
	CM	H-CARK2-1800-CM-EL15	63578	68.1
1800	CL	H-CARK2-1800-CL-EL15	63579	69.4
	CLL	H-CARK2-1800-CLL-EL15	63580	73.8
	CM	H-CARK2-2000-CM-EL15	63581	74.8
	CL	H-CARK2-2000-CL-EL15	63582	76.3
2000	CLL	H-CARK2-2000-CLL-EL15	63583	81.1
	CM	H-CARK2-2200-CM-EL15	63584	82.1
	CL	H-CARK2-2200-CL-EL15	63585	83.7
	CLL	H-CARK2-2200-CLL-EL15	63586	89
2400	CM	H-CARK2-2400-CM-EL15	63587	87.1
	CL	H-CARK2-2400-CL-EL15	63588	88.9
	CLL	H-CARK2-2400-CLL-EL15	63589	94.7
2600	CM	H-CARK2-2600-CM-EL15	63590	95.7
	CL	H-CARK2-2600-CL-EL15	63591	97.7
	CLL	H-CARK2-2600-CLL-EL15	63592	103.9
2800	CM	H-CARK2-2800-CM-EL15	63593	102.2
	CL	H-CARK2-2800-CL-EL15	63594	104.3
	CLL	H-CARK2-2800-CLL-EL15	63595	111
3000	CM	H-CARK2-3000-CM-EL15	63596	107.7
	CL	H-CARK2-3000-CL-EL15	63597	110
	CLL	H-CARK2-3000-CLL-EL15	63598	117.2

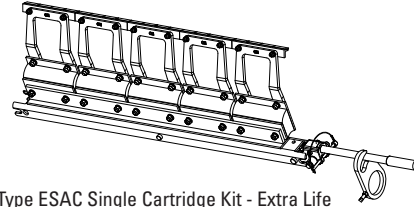

H-Type ESAC Single Cartridge Kit - Extra Life

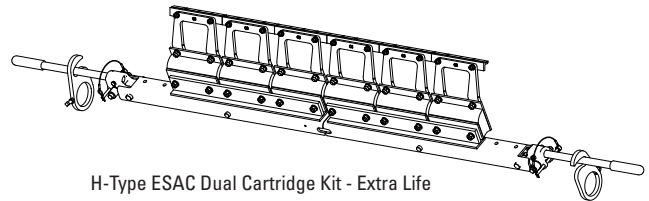

H-Type ESAC Dual Cartridge Kit - Extra Life

Stock items (non-shaded) refer to (*) for specific lead time, if not specified, standard lead time applies.

Non-stock items (shaded) please contact Flexco for dispatch options and lead times.

Product Ordering Information

H-Type ESAC with Extra Life V-Tips (Stainless Steel) HD Primary Cleaner with Enhanced Service Advantage Cartridge™

Stainless Steel H-Type® ESAC with Extra Life V-Tips

TIP WIDTH	ARM SIZE	ORDERING NUMBER	ITEM CODE	Wght. KG.
Single Cartridge				
600	CS	HV-600-SAC-CS-S/S-EL15	63227	74.2
	CM	HV-600-SAC-CM-S/S-EL15	63228	74.9
	CL	HV-600-SAC-CL-S/S-EL15	63229	75.3
800	CS	HV-800-SAC-CS-S/S-EL15	63230	86.5
	CM	HV-800-SAC-CM-S/S-EL15	63231	87.5
	CL	HV-800-SAC-CL-S/S-EL15	63232	88.1
1000	CS	HV-1000-SAC-CS-S/S-EL15	63233	94.9
	CM	HV-1000-SAC-CM-S/S-EL15	63234	96.2
	CL	HV-1000-SAC-CL-S/S-EL15	63235	96.9
1200	CS	HV-1200-SAC-CS-S/S-EL15	63236	103.3
	CM	HV-1200-SAC-CM-S/S-EL15	63237	104.7
	CL	HV-1200-SAC-CL-S/S-EL15	63238	105.6
1400	CS	HV-1400-SAC-CS-S/S-EL15	63239	115.9
	CM	HV-1400-SAC-CM-S/S-EL15	63240	117.5
	CL	HV-1400-SAC-CL-S/S-EL15	63241	118.6
1600	CM	HV-1600-SAC-CM-S/S-EL15	63242	130.0
	CL	HV-1600-SAC-CL-S/S-EL15	63243	131.3
	CLL	HV-1600-SAC-CLL-S/S-EL15	63244	135.2
1800	CM	HV-1800-SAC-CM-S/S-EL15	63245	137.2
	CL	HV-1800-SAC-CL-S/S-EL15	63246	138.5
	CLL	HV-1800-SAC-CLL-S/S-EL15	63247	142.8
Dual Cartridge				
1200	CS	HV-1200-2SAC-CS-S/S-EL15	63453	128.7
	CM	HV-1200-2SAC-CM-S/S-EL15	63454	130.3
	CL	HV-1200-2SAC-CL-S/S-EL15	63455	131.2
	CLL	HV-1200-2SAC-CLL-S/S-EL15	63456	134.1
1400	CS	HV-1400-2SAC-CS-S/S-EL15	63457	137.4
	CM	HV-1400-2SAC-CM-S/S-EL15	63458	139.0
	CL	HV-1400-2SAC-CL-S/S-EL15	63459	140.1
	CLL	HV-1400-2SAC-CLL-S/S-EL15	63460	143.4
1600	CM	HV-1600-2SAC-CM-S/S-EL15	63461	147.9
	CL	HV-1600-2SAC-CL-S/S-EL15	63462	149.1
	CLL	HV-1600-2SAC-CLL-S/S-EL15	63463	152.9
1800	CM	HV-1800-2SAC-CM-S/S-EL15	63464	159.5
	CL	HV-1800-2SAC-CL-S/S-EL15	63465	160.9
	CLL	HV-1800-2SAC-CLL-S/S-EL15	63466	163.8
2000	CM	HV-2000-2SAC-CM-S/S-EL15	63467	169.2
	CL	HV-2000-2SAC-CL-S/S-EL15	63468	170.7
	CLL	HV-2000-2SAC-CLL-S/S-EL15	63469	174.0
2200	CM	HV-2200-2SAC-CM-S/S-EL15	63470	182.4
	CL	HV-2200-2SAC-CL-S/S-EL15	63471	184.1
	CLL	HV-2200-2SAC-CLL-S/S-EL15	63472	187.7
2400	CM	HV-2400-2SAC-CM-S/S-EL15	63473	187.5
	CL	HV-2400-2SAC-CL-S/S-EL15	63474	189.3
	CLL	HV-2400-2SAC-CLL-S/S-EL15	63475	193.3
2600	CM	HV-2600-2SAC-CM-S/S-EL15	63476	211.2
	CL	HV-2600-2SAC-CL-S/S-EL15	63477	213.2
	CLL	HV-2600-2SAC-CLL-S/S-EL15	63478	217.4
2800	CM	HV-2800-2SAC-CM-S/S-EL15	63479	220.9
	CL	HV-2800-2SAC-CL-S/S-EL15	63480	223.0
	CLL	HV-2800-2SAC-CLL-S/S-EL15	63481	227.7
3000	CM	HV-3000-2SAC-CM-S/S-EL15	63482	230.0
	CL	HV-3000-2SAC-CL-S/S-EL15	63483	232.3
	CLL	HV-3000-2SAC-CLL-S/S-EL15	63484	237.2

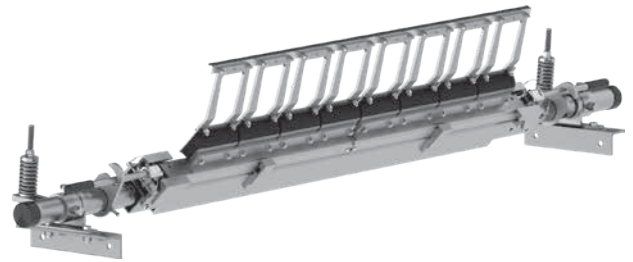

Stainless Steel H-Type ESAC Dual HD Primary Cleaner

Replacement V-Tips

ORDERING NUMBER	ITEM CODE	WT. KG.
HVT8-S/S	75419	0.9
HVPT-S/S	73631	1.2

Replacement Suspension Arms SS

SIZE	ORDERING NUMBER	ITEM CODE	WT. KG.
CS	HSA8CS-S/S	62509	1.1
CM	HSA8CM-S/S	62510	1.3
CL	HSA8CL-S/S	62511	1.5
CLL	HSA8CLL-S/S	62512	1.7

Suspension Arm Size

HEAD PULLEY DIAMETER + BELT & LAGGING mm	SUSPENSION ARM SIZE
500-799	CS
800-999	CM
1000-1199	CL
1200-1700	CLL

Over 1700mm - contact Flexco

Tips required per cleaner size

BELT WIDTH mm	BELT COVERAGE mm	V-TIPS REQUIRED
600	600	3
800	800	4
1000	1000	5
1200	1200	6
1400	1400	7
1600	1600	8
1800	1800	9
2000	2000	10
2200	2200	11
2400	2400	12
2600	2600	13
2800	2800	14
3000	3000	15

Stock items (non-shaded) refer to (*) for specific lead time, if not specified, standard lead time applies.

Non-stock items (shaded) please contact Flexco for dispatch options and lead times.

Product Ordering Information

H-Type ESAC with Extra Life V-Tips (Stainless Steel) HD Primary Cleaner with Enhanced Service Advantage Cartridge™

H-Type ESAC Stainless Steel Replacement Cartridge Kits with Extra Life V-Tips

TIP WIDTH	ARM SIZE	ORDERING NUMBER	ITEM CODE	Wght. KG.
Single Cartridge Kits				
600	CS	H CARK-600-CS-S/S-EL15	63652	23.2
	CM	H CARK-600-CM-S/S-EL15	63653	24
	CL	H CARK-600-CL-S/S-EL15	63654	24.5
800	CS	H CARK-800-CS-S/S-EL15	63655	30.3
	CM	H CARK-800-CM-S/S-EL15	63656	31.3
	CL	H CARK-800-CL-S/S-EL15	63657	31.9
1000	CS	H CARK-1000-CS-S/S-EL15	63658	36.1
	CM	H CARK-1000-CM-S/S-EL15	63659	37.4
	CL	H CARK-1000-CL-S/S-EL15	63660	38.2
1200	CS	H CARK-1200-CS-S/S-EL15	63661	41.4
	CM	H CARK-1200-CM-S/S-EL15	63662	43.3
	CL	H CARK-1200-CL-S/S-EL15	63663	44.2
1400	CS	H CARK-1400-CS-S/S-EL15	63664	49
	CM	H CARK-1400-CM-S/S-EL15	63665	50.8
	CL	H CARK-1400-CL-S/S-EL15	63666	51.9
1600	CM	H CARK-1600-CS-S/S-EL15	63667	58.1
	CL	H CARK-1600-CM-S/S-EL15	63668	59.3
	CLL	H CARK-1600-CL-S/S-EL15	63669	63.1
1800	CM	H CARK-1800-CS-S/S-EL15	63670	66.2
	CL	H CARK-1800-CM-S/S-EL15	63671	67.6
	CLL	H CARK-1800-CL-S/S-EL15	63672	71.9
Dual Cartridge Kits				
1200	CS	H-CARK2-1200-CS-S/S-EL15	63599	46.2
	CM	H-CARK2-1200-CM-S/S-EL15	63600	47.8
	CL	H-CARK2-1200-CL-S/S-EL15	63601	48.7
	CLL	H-CARK2-1200-CLL-S/S-EL15	63602	51.6
1400	CS	H-CARK2-1400-CS-S/S-EL15	63603	51.8
	CM	H-CARK2-1400-CM-S/S-EL15	63604	53.6
	CL	H-CARK2-1400-CL-S/S-EL15	63605	54.6
	CLL	H-CARK2-1400-CLL-S/S-EL15	63606	58
1600	CM	H-CARK2-1600-CM-S/S-EL15	63607	59.4
	CL	H-CARK2-1600-CL-S/S-EL15	63608	60.6
	CLL	H-CARK2-1600-CLL-S/S-EL15	63609	64.4
	CM	H-CARK2-1800-CM-S/S-EL15	63610	68.1
1800	CL	H-CARK2-1800-CL-S/S-EL15	63611	69.4
	CLL	H-CARK2-1800-CLL-S/S-EL15	63612	73.8
	CM	H-CARK2-2000-CM-S/S-EL15	63613	74.8
	CL	H-CARK2-2000-CL-S/S-EL15	63614	76.3
2000	CLL	H-CARK2-2000-CLL-S/S-EL15	63615	81.1
	CM	H-CARK2-2200-CM-S/S-EL15	63616	82.1
	CL	H-CARK2-2200-CL-S/S-EL15	63617	83.7
	CLL	H-CARK2-2200-CLL-S/S-EL15	63618	89
2400	CM	H-CARK2-2400-CM-S/S-EL15	63619	87.1
	CL	H-CARK2-2400-CL-S/S-EL15	63620	88.9
	CLL	H-CARK2-2400-CLL-S/S-EL15	63621	94.7
	CM	H-CARK2-2600-CM-S/S-EL15	63622	95.7
2600	CL	H-CARK2-2600-CL-S/S-EL15	63623	97.7
	CLL	H-CARK2-2600-CLL-S/S-EL15	63624	103.9
	CM	H-CARK2-2800-CM-S/S-EL15	63625	102.2
	CL	H-CARK2-2800-CL-S/S-EL15	63626	104.3
2800	CLL	H-CARK2-2800-CLL-S/S-EL15	63627	111
	CM	H-CARK2-3000-CM-S/S-EL15	63628	107.7
	CL	H-CARK2-3000-CL-S/S-EL15	63629	110
	CLL	H-CARK2-3000-CLL-S/S-EL15	63630	117.2

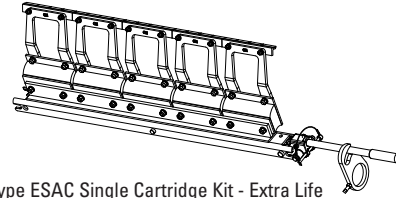

H-Type ESAC Single Cartridge Kit - Extra Life

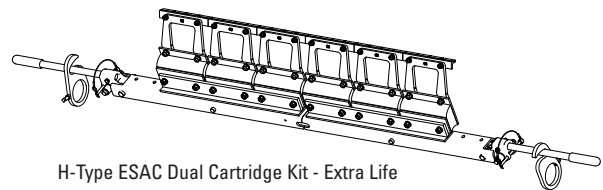

H-Type ESAC Dual Cartridge Kit - Extra Life

Stock items (non-shaded) refer to (*) for specific lead time, if not specified, standard lead time applies.

Non-stock items (shaded) please contact Flexco for dispatch options and lead times.

Replacement Parts List

H-Type ESAC with Extra Life V-Tips Single HD Primary Cleaner with Enhanced Service Advantage Cartridge™

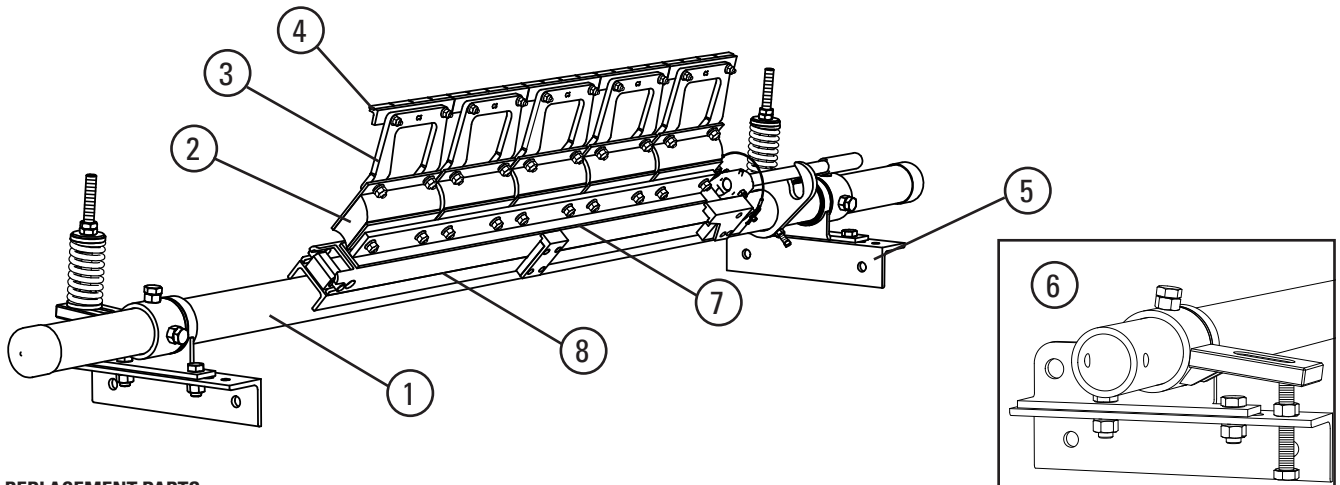

REPLACEMENT PARTS

REF	DESCRIPTION	MILD STEEL			STAINLESS STEEL		
		ORDERING NUMBER	ITEM CODE	WT. KG.	ORDERING NUMBER	ITEM CODE	WT. KG.
1	H-Type Single ESAC Cartridge Pole	HCP-600	62751	30.5	HCP-600-S/S	62757	31.4
		HCP-800	62752	35.6	HCP-800-S/S	62758	36.7
		HCP-1000	62753	38.1	HCP-1000-S/S	62759	39.3
		HCP-1200	62754	40.7	HCP-1200-S/S	62760	42
		HCP-1400	62755	45.9	HCP-1400-S/S	62761	47.3
		HCP-1800	62756	51.0	HCP-1800-S/S	62762	52.6
2	HD Cushion	HSHD	73483	2.0	HSHD-S/S	76467	2.0
3	Suspension Arm	HSA8CS	62505	0.9	HSA8CS-S/S	62509	1.0
		HSA8CM	62506	1.1	HSA8CM-S/S	62510	1.2
		HSA8CL	62507	1.3	HSA8CL-S/S	62511	1.3
		HSA8CLL	62508	1.8	HSA8CLL-S/S	62512	1.8
4	HV Tips	HSA200	73489	0.5	HVT8-S/S	75419	0.6
	HV EL15 Tips	HSA200-EL15	76027	0.5	HVT8-EL15-S/S	62254	0.6
	-	-	-	-	HVPT-S/S	73631	0.6
5	Black Compression Spring Side Assembly (to 1600 belt width max)	H73CSK-B	62749	17.8	H73CSK-B-S/S	62750	18.3
	Gold Compression Spring Side Assembly (to 2400 belt width max)	H73CSK-G	62743	17.8	H73CSK-G-S/S	62744	18.3
6	Bolt Tension Side Assembly	H73BTK	63079	15.1	H73BTK-S/S	63080	15.6
REF	DESCRIPTION	TIP WIDTH	ORDERING NUMBER	ITEM CODE	WT. KG.		
7	H-Type Cartridge Adapter Plate	600	H-SAC-AP-600	62452	3.5		
		800	H-SAC-AP-800	62453	4.8		
		1000	H-SAC-AP-1000	62454	6.0		
		1200	H-SAC-AP-1200	62455	7.3		
		1400	H-SAC-AP-1400	62456	8.5		
		1600	H-SAC-AP-1600	62457	9.8		
8	SAC Replacement Single Cartridge	1800	H-SAC-AP-1800	62458	11.0		
		600	CART-24/600-S/S	78576	4.5		
		800	CART-36/900-S/S	78578	6.7		
		1000	CART-42/1050-S/S	78579	7.8		
		1200	CART-48/1200-S/S	78580	8.9		
		1400	CART-60/1500-S/S	78582	11.3		
		1600	CART-72/1800-S/S	78583	13.5		
1800							

HV/HVP Single SAC Black Spring Length Chart (for optimal blade tensioning)

Belt Width	CS	CM	CL	CLL
600	111	110	109	107
800	109	107	107	104
1000	106	105	104	100
1200	104	102	101	97
1400	102	100	98	93
1600	100	97	96	90
1800	97	95	93	-

HV/HVP Single SAC Gold Spring Length Chart (for optimal blade tensioning)

Belt Width	CS	CM	CL	CLL
600	113	113	112	111
800	112	111	111	109
1000	111	110	109	107
1200	109	108	107	105
1400	108	106	106	102
1600	106	105	104	100
1800	105	103	102	98

HV/HVP Dual SAC Gold Spring Length Chart (for optimal blade tensioning)

Belt Width	CS	CM	CL	CLL
1200	109	108	108	105
1400	108	107	106	103
1600	107	105	104	101
1800	105	104	103	99
2000	104	102	101	96
2200	103	101	99	94

HV/HVP Dual SAC Silver Spring Length Chart (for optimal blade tensioning)

Belt Width	CS	CM	CL	CLL
2200	159	158	157	154
2400	158	157	156	153
2600	157	156	155	151
2800	157	155	154	150
3000	156	154	153	149

Stock items (non-shaded) refer to (*) for specific lead time, if not specified, standard lead time applies.

Non-stock items (shaded) please contact Flexco for dispatch options and lead times.

Replacement Parts List

H-Type ESAC with Extra Life V-Tips Dual HD Primary Cleaner with Enhanced Service Advantage Cartridge™

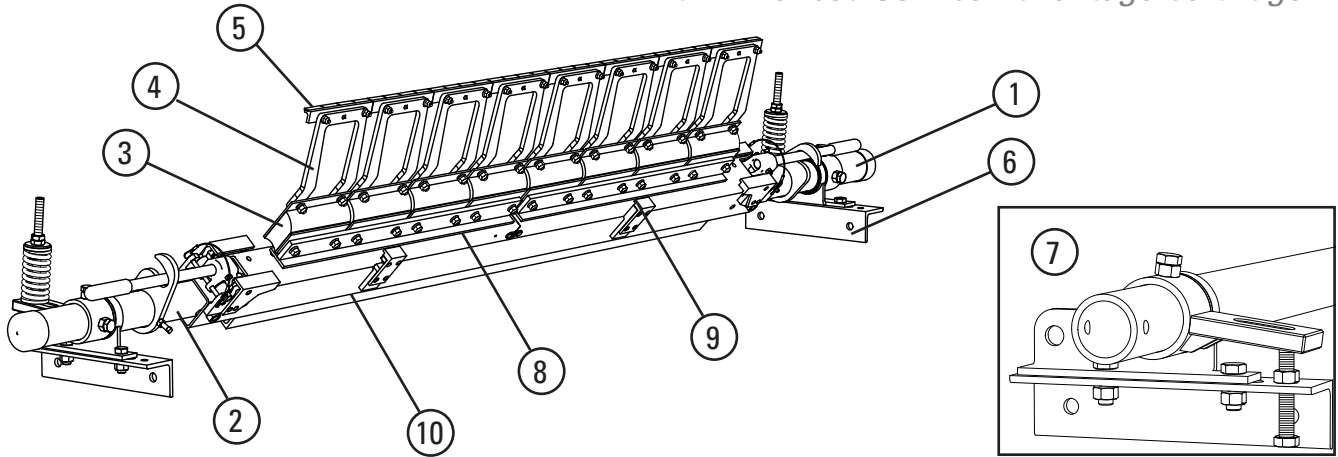

REPLACEMENT PARTS

REF	DESCRIPTION	MILD STEEL			STAINLESS STEEL		
		ORDERING NUMBER	ITEM CODE	WT. KG.	ORDERING NUMBER	ITEM CODE	WT. KG.
1	H-Type Dual ESAC Centre Pole	H2CP-1200	62763	39.7	H2CP-1200-S/S	62801	39.7
		H2CP-1400	62764	42.6	H2CP-1400-S/S	62802	42.6
		H2CP-1600	62765	45.7	H2CP-1600-S/S	62803	45.7
		H2CP-1800	62766	48.6	H2CP-1800-S/S	62804	48.6
		H2CP-2000	62767	51.6	H2CP-2000-S/S	62805	51.6
		H2CP-2400	62768	57.6	H2CP-2400-S/S	62806	57.6
		H2CP-2600	62769	71.0	H2CP-2600-S/S	62807	71.0
		H2CP-2800	62770	74.3	H2CP-2800-S/S	62808	74.3
		H2CP-3000	62771	77.8	H2CP-3000-S/S	62809	77.8
2	Extender Pole	MHP-EP	76392	24.5	MHP-EP-S/S	77599	24.5
3	HD Cushion	HSHD	73483	2.0	HSHD-S/S	76467	2.0
4	Suspension Arm	HSA8CS	62505	0.9	HSA8CS-S/S	62509	1.0
		HSA8CM	62506	1.1	HSA8CM-S/S	62510	1.2
		HSA8CL	62507	1.3	HSA8CL-S/S	62511	1.3
		HSA8CLL	62508	1.8	HSA8CLL-S/S	62512	1.8
5	HV Tips	HSA200	73489	0.5	HVT8-S/S	75419	0.6
	HV EL15 Tips	HSA200-EL15	76027	0.5	HVT8-EL15-S/S	63566	0.6
-	-	-	-	-	HVPT-S/S	73631	0.6
6	Black Compression Spring Side Assembly (to 1600 belt width max)	H73CSK-B	62749	17.8	H73CSK-B-S/S	62750	18.3
	Gold Compression Spring Side Assembly (to 2400 belt width max)	H73CSK-G	62743	17.8	H73CSK-G-S/S	62744	18.3
	Silver 6" Compression Spring Side Assembly (above 2400)	H73CSK-S	62745	18.0	H73CSK-S-S/S	62746	18.4
7	Bolt Tension Side Assembly	H73BTK	63079	15.1	H73BTK-S/S	63080	15.6

REF	DESCRIPTION	TIP WIDTH	ITEM 8 / LEFT HAND			ITEM 9 / RIGHT HAND		
			ORDERING NUMBER	ITEM CODE	WT. KG.	ORDERING NUMBER	ITEM CODE	WT. KG.
8 & 9	H-Type Cartridge Adapter Plate	1200	H-SAC-AP-600	62452	3.5	H-SAC-AP-600	62452	3.5
		1400	H-SAC-AP-800	62453	4.8	H-SAC-AP-600	62452	3.5
		1600	H-SAC-AP-800	62453	4.8	H-SAC-AP-800	62453	4.8
		1800	H-SAC-AP-1000	62454	6.0	H-SAC-AP-800	62453	4.8
		2000	H-SAC-AP-1000	62454	6.0	H-SAC-AP-1000	62454	6.0
		2200	H-SAC-AP-1200	62455	7.3	H-SAC-AP-1000	62454	6.0
		2400	H-SAC-AP-1200	62455	7.3	H-SAC-AP-1200	62455	7.3
		2600	H-SAC-AP-1400	62456	8.5	H-SAC-AP-1200	62455	7.3
		2800	H-SAC-AP-1400	62456	8.5	H-SAC-AP-1400	62456	8.5
3000	H-SAC-AP-1600	62457	9.8	H-SAC-AP-1400	62456	8.5		

REF	DESCRIPTION	TIP WIDTH	ORDERING NUMBER	ITEM CODE	WT. KG.
10	SAC Replacement Dual Cartridge	1200	CART2-60/1500-S/S	78584	11.2
		1400	CART2-66/1650-S/S	78634	12.3
		1600	CART2-72/1800-S/S	78585	13.4
		1800	CART2-78/1950-S/S	78635	14.5
		2000	CART2-84/2100-S/S	78586	15.6
		2200	CART2-96/2400-S/S	78587	17.8
		2400			
		2600	CART2-114/2850-S/S	78639	23.7
2800	CART2-120/3000-S/S	78588	22.6		
3000	CART2-126/3150-S/S	78640	23.7		

Stock items (non-shaded) refer to (*) for specific lead time, if not specified, standard lead time applies.
Non-stock items (shaded) please contact Flexco for dispatch options and lead times.

Replacement Parts List

H-Type with PCST Optional Tensioners

ATV Replacement Parts

REF	DESCRIPTION	ORDERING NUMBER	ITEM CODE	WT. KG.
1	Air Primary Mount Bracket Stainless Steel	AIR HDMRK S/S	62034	2.0
2	Bearing Repair Kit 60mm	HBRK-S/S-60	75422	1.5
	Bearing Repair Kit 73mm	HBRK-S/S-73	76246	2.0
3	Air Primary Adjust Arm 60mm	AIR HARK-S/S-60	62035	1.5
	Air Primary Adjust Arm 73mm	AIR HARK-S/S-73	64175	2.0
4	Air Bag Primary	AIR BAG P	62036	0.5
5	Hex Nut	HEX NUT	G1211	0.1
6	Air Line Adapter	ATV-NIP	62037	0.1
-	Primary Ait Tension Kit 60mm (incl. 2 ea items AIR HDMRK S/S, HBRK-S/S-60, AIR HARK-S/S-60, AIR BAG P, HEX NUT, ATV-NIP)	HATDMK-S/S	63861	11.0
-	Primary Ait Tension Kit 73mm (incl. 2 ea items AIR HDMRK S/S, HBRK-S/S-73, AIR HARK-S/S-73, AIR BAG P, HEX NUT, ATV-NIP)	HDATDMK-S/S	63862	14.0

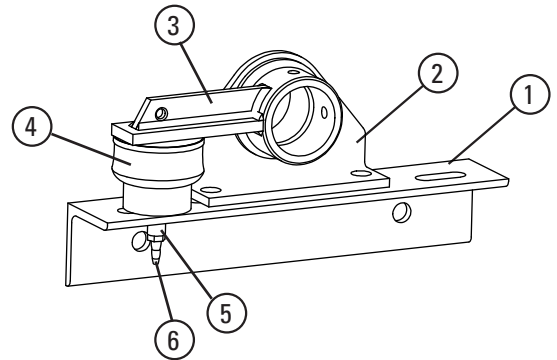

P-CST Replacement Parts - Mild Steel PCST 60mm

REF	DESCRIPTION	ORDERING NUMBER	ITEM CODE	WT. KG.
1	H Bearing Bush 60mm	HCSBB-60	62513	0.1
2	Acme Pivot Rod Kit	ACME-PRK	62496	0.6
3	Acme Nut	ACME-N	62591	0.1
4a	Spring Black (To 1600 Belt Width Max)	STS-B	75844	0.5
4b	Spring Gold (To 2400 Belt Width Max)	STS-G	78142	0.5
5	Spring Bush Kit (Black/Gold)	HCSSB-B/G	62589	0.1
6	Torque Arm Kit 60mm	ESTAK-EST	76406	1.6
-	Black 60mm Compression Spring Side Assembly (to 1600 belt width max)	H60CSK-B	62747	16.8
-	Gold 60mm Compression Spring Side Assembly (to 2400 belt width max)	H60CSK-G	62741	16.8

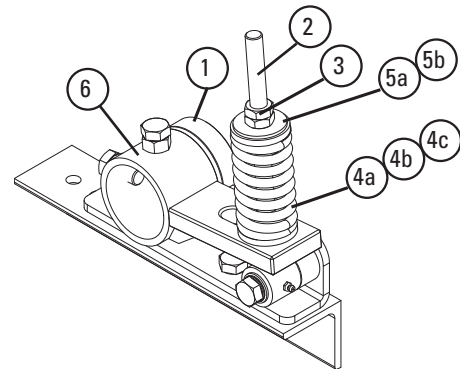

P-CST Replacement Parts - Mild Steel PCST 73mm

REF	DESCRIPTION	ORDERING NUMBER	ITEM CODE	WT. KG.
1	H Bearing Bush 73mm	HCSBB-73	62514	2.0
2	Acme Pivot Rod Kit	ACME-PRK	62496	0.6
3	Acme Nut	ACME-N	62591	0.1
4a	Spring Black (To 1600 Belt Width Max)	STS-B	75844	0.5
4b	Spring Gold (To 2400 Belt Width Max)	STS-G	78142	0.5
4c	Spring Silver (Above 2400 Belt Width)	PSTS-S	75899	0.5
5a	Spring Bush (Black/Gold)	HCSSB-B/G	62589	0.1
5b	Spring Bush (Silver)	HCSSB-S	62590	0.2
6	Torque Arm Kit 73mm	HCSTAK	62494	1.6
-	Black 73mm Compression Spring Side Assembly (to 1600 belt width max)	H73CSK-B	62749	17.8
-	Gold 73mm Compression Spring Side Assembly (to 2400 belt width max)	H73CSK-G	62743	17.8
-	Silver 73mm Compression Spring Side Assembly (above 2400)	H73CSK-S	62745	18

P-CST Replacement Parts - Stainless Steel PCST 73mm

REF	DESCRIPTION	ORDERING NUMBER	ITEM CODE	WT. KG.
1	H Bearing Bush 73mm	HCSBB-73	62514	2.0
2	Acme Pivot Rod Kit	ACME-PRK	62496	0.6
3	Acme Nut	ACME-N	62591	0.1
4a	Spring Black (To 1600 Belt Width Max)	STS-B-S/S	77632	0.5
4b	Spring Gold (To 2400 Belt Width Max)	STS-G-S/S	79057	0.5
4c	Spring Silver (Above 2400 Belt Width)	PSTS-S-S/S	79056	0.5
5a	Spring Bush (Black/Gold)	HCSSB-B/G	62589	0.1
5b	Spring Bush (Silver)	HCSSB-S	62590	0.2
6	Torque Arm Kit 73mm	HCSTAK-S/S	62495	1.6
-	Black 73mm Compression Spring Side Assembly (to 1600 belt width max)	H73CSK-B-S/S	62750	18.3
-	Gold 73mm Compression Spring Side Assembly (to 2400 belt width max)	H73CSK-G-S/S	62744	18.3
-	Silver 73mm Compression Spring Side Assembly (above 2400 belt width max)	H73CSK-S-S/S	62746	18.4

P-CST Replacement Parts - Stainless Steel PCST 60mm

REF	DESCRIPTION	ORDERING NUMBER	ITEM CODE	WT. KG.
1	H Bearing Bush 60mm	HCSBB-60	62513	0.1
2	Acme Pivot Rod Kit	ACME-PRK	62496	0.6
3	Acme Nut	ACME-N	62591	0.1
4a	Spring Black (To 1600 Belt Width Max)	STS-B-S/S	77632	0.5
4b	Spring Gold (To 2400 Belt Width Max)	STS-G-S/S	79057	0.5
5	Spring Bush Kit (Black/Gold)	HCSSB-B/G	62589	0.1
6	Torque Arm Kit 60mm	ESTAK-EST-S/S	78849	1.6
-	Black 60mm Compression Spring Side Assembly (to 1600 belt width max)	H60CSK-B-S/S	62748	17.3
-	Gold 60mm Compression Spring Side Assembly (to 2400 belt width max)	H60CSK-G-S/S	62742	17.3

Stock items (non-shaded) refer to (*) for specific lead time, if not specified, standard lead time applies.

Non-stock items (shaded) please contact Flexco for dispatch options and lead times.

Product Ordering Information

Y-Type™ Standard Duty Secondary Cleaner with Carbide or Polyurethane Blades

Y-Type™ Standard Duty with Purple Polyurethane Blades and YST Tension

BELT WIDTH	ORDERING NUMBER	ITEM CODE	WT. KGS.
450	YT-450S	83229	26.8
600	YT-600S	83230	29.5
750	YT-750S	83231	32.3
900	YT-900S	83232	35.0
1050	YT-1050S	83233	37.7
1200	YT-1200S	83234	40.5

Lead time: 2 weeks

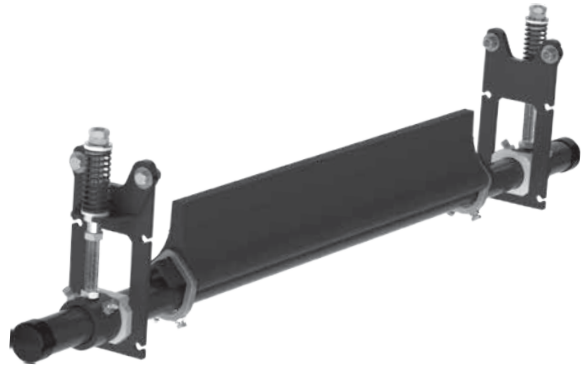

Y-Type™ Standard Duty with Carbide Blades and Bolt Tension

BELT WIDTH	ORDERING NUMBER	ITEM CODE	WT. KGS.
450	YTC-450	83223	30.6
600	YTC-600	83224	33.3
750	YTC-750	83225	36.1
900	YTC-900	83226	38.8
1050	YTC-1050	83227	41.5
1200	YTC-1200	83228	44.3

Lead time: 2 weeks

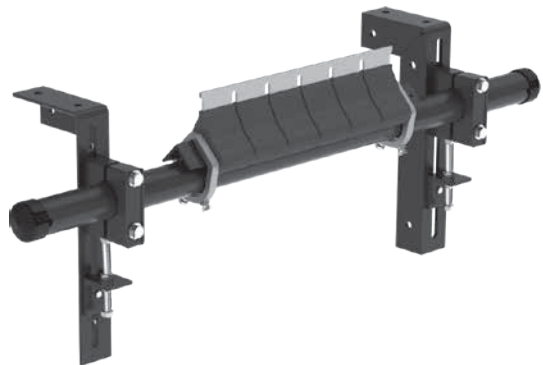

Y-Type™ Standard Duty with Carbide Blades and YST Tension

BELT WIDTH	ORDERING NUMBER	ITEM CODE	WT. KGS.
450	YT-TC-450S	83241	25.0
600	YT-TC-600S	83242	27.3
750	YT-TC-750S	83243	29.5
900	YT-TC-900S	83244	31.8
1050	YT-TC-1050S	83245	34.5
1200	YT-TC-1200S	83246	37.3

Lead time: 2 weeks

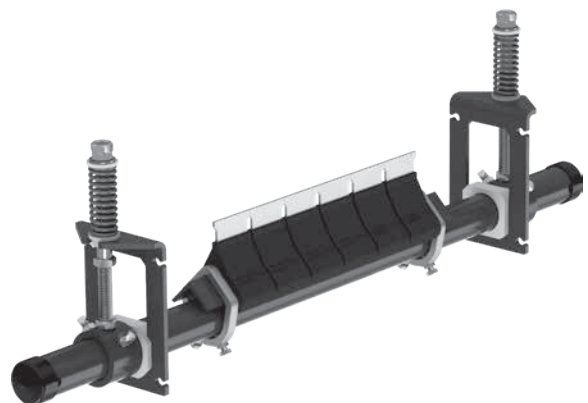

Stock items (non-shaded) refer to (*) for specific lead time, if not specified, standard lead time applies.
 Non-stock items (shaded) please contact Flexco for dispatch options and lead times.

Product Ordering Information

Y-Type™ Heavy Duty Secondary Cleaner with HD Carbide or Urethane Blades

Y-Type™ HD with Purple Polyurethane Blades and YST Tension

BELT WIDTH	ORDERING NUMBER	ITEM CODE	WT. KGS.
900	YTHD-900S	83120	27.1
1050	YTHD-1050S	83121	29.0
1200	YTHD-1200S	83122	30.9
1350	YTHD-1350S	83123	32.8
1500	YTHD-1500S	83124	34.7
1800	YTHD-1800S	83126	38.5

Lead time: 2 weeks

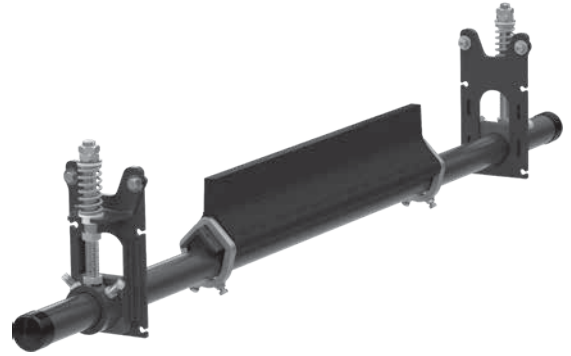

Y-Type™ HD with Carbide Blades and Bolt Tension

BELT WIDTH	ORDERING NUMBER	ITEM CODE	WT. KGS.
900	YTCHD-900	83099	26.9
1050	YTCHD-1050	83100	29.4
1200	YTCHD-1200	83101	31.4
1350	YTCHD-1350	83102	33.4
1500	YTCHD-1500	83103	35.3
1800	YTCHD-1800	83105	39.3

Lead time: 2 weeks





Y-Type™ HD with Carbide Blades and YST Tension

BELT WIDTH	ORDERING NUMBER	ITEM CODE	WT. KGS.
900	YTHD-TC-900S	83134	26.9
1050	YTHD-TC-1050S	83135	29.4
1200	YTHD-TC-1200S	83136	31.4
1350	YTHD-TC-1350S	83137	33.4
1500	YTHD-TC-1500S	83138	35.3
1800	YTHD-TC-1800S	83140	39.3

Lead time: 2 weeks



 Stock items (non-shaded) refer to (*) for specific lead time, if not specified, standard lead time applies.

 Non-stock items (shaded) please contact Flexco for dispatch options and lead times.

Product Ordering Information

Y-Type™ Secondary Cleaner with Carbide or Urethane Blades

Replacment Blades/Cartridges - Standard Duty Carbide

BELT WIDTH	ORDERING NUMBER	ITEM CODE	WT. KGS.
-	YT-C*	79574	0.5
450	YCART-18/450-TC	79811	5.7
600	YCART-24/600-TC	79812	7.5
750	YCART-30/750-TC	79813	9.3
900	YCART-36/900-TC	79814	11.0
1050	YCART-42/1050-TC	79815	12.8
1200	YCART-48/1200-TC	79816	14.5

*Single 75mm (3") blade segment
Lead time: 2 weeks

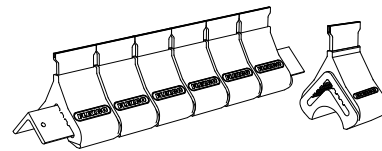

Y-Type™ Standard Duty
Carbide Blade Cartridge

Replacment Blades/Cartridges - Standard Duty Purple Polyurethane

BELT WIDTH	ORDERING NUMBER	ITEM CODE	WT. KGS.
-	YT-P*	79573	0.5
450	YCART-18/450-P	79617	6.0
600	YCART-24/600-P	79618	7.8
750	YCART-30/750-P	79619	9.6
900	YCART-36/900-P	79620	11.4
1050	YCART-42/1050-P	79621	13.2
1200	YCART-48/1200-P	79622	15.0

*Single 75mm (3") blade segment
Lead time: 2 weeks

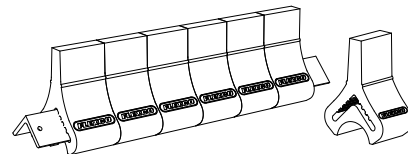

Y-Type™ Standard Duty
Polyurethane Blade Cartridge

Replacment Blades/Cartridges - Heavy-Duty Carbide

BELT WIDTH	ORDERING NUMBER	ITEM CODE	WT. KGS.
-	YT-HDC*	79728	0.8
900	YCART-36/900-HDTC	79829	17.5
1050	YCART-42/1050-HDTC	79830	20.2
1200	YCART-48/1200-HDTC	79831	23.0
1350	YCART-54/1350-HDTC	79832	25.8
1500	YCART-60/1500-HDTC	79833	28.6
1800	YCART-72/1800-HDTC	79834	34.2

*Single 75mm (3") blade segment
Lead time: 2 weeks

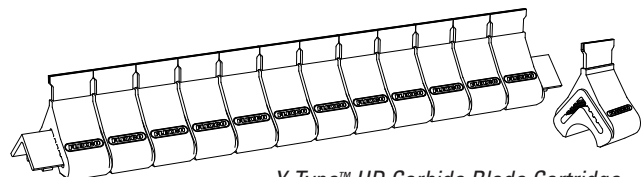

Y-Type™ HD Carbide Blade Cartridge

Replacment Blades/Cartridges - Heavy-Duty Purple Polyurethane

BELT WIDTH	ORDERING NUMBER	ITEM CODE	WT. KGS.
-	YT-HDP*	79677	0.8
900	YCART-36/900-HDP	79817	16.6
1050	YCART-42/1050-HDP	79818	19.2
1200	YCART-48/1200-HDP	79819	21.9
1350	YCART-54/1350-HDP	79820	24.5
1500	YCART-60/1500-HDP	79821	27.2
1800	YCART-72/1800-HDP	79822	32.5

*Single 75mm (3") blade segment
Lead time: 2 weeks

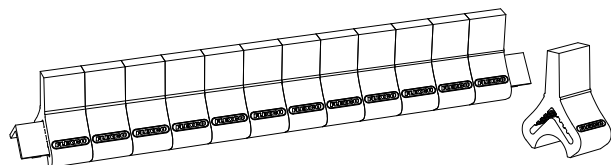

Y-Type™ HD Polyurethane Blade Cartridge

Stock items (non-shaded) refer to (*) for specific lead time, if not specified, standard lead time applies.
Non-stock items (shaded) please contact Flexco for dispatch options and lead times.

Specifications & Guidelines

Y-Type™ Standard Duty Secondary Cleaner with Carbide or Polyurethane Blades

Pole Length Specifications

Cleaner Size		Pole Length		Maximum Conveyor Span	
mm	in.	mm	in.	mm	in.
450	18	1200	48	1025	40
600	24	1350	54	1175	46
750	30	1500	60	1325	52
900	36	1650	66	1475	58
1050	42	1800	72	1625	64
1200	48	1950	78	1775	70

Pole Length - Belt +750mm (30")
Pole Diameter - 60mm (2-3/8")

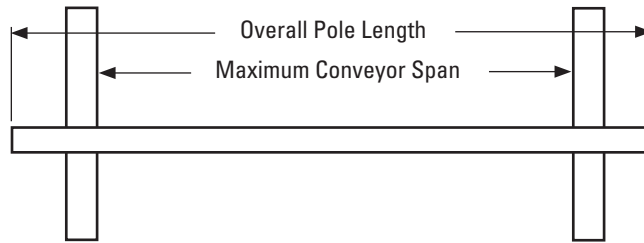

Clearance Guidelines for Installation

Cleaner Type	Belt Width/ Cleaner Size		Horizontal Clearance Required		Vertical Clearance Required	
	mm	in.	mm	in.	mm	in.
Y-Type® Polyurethane	450 - 1200	18 - 48	110	4-1/4	210	8-1/4
Y-Type Carbide	450 - 1200	18 - 48	110	4-1/4	184	7-3/4

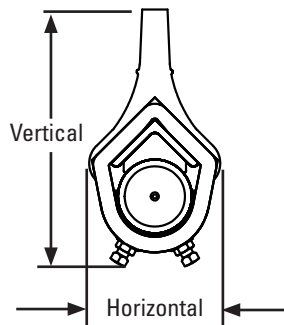

Y-Type Blade Specifications

Cushion	Durometer	Temperature Range
Purple (Standard)	86A	-35° to 82° C -30° to 180° F
Carbide	86A	-35° to 82° C -30° to 180° F

‡ All ingredients used in the Polyurethane formulation of this blade comply with the relevant requirements of 21 CFR (FDA Code of Federal Regulations) for use in repeated bulk dry food applications

Spring Length Chart

Blade Width		Carbide Tip		Polyurethane Tip			
		Silver Springs		Yellow Springs		Purple Springs	
mm	in.	mm	in.	mm	in.	mm	in.
450	18	105	4 1/8	83	3 1/4	92	3 5/8
600	24	102	4	73	2 7/8	86	3 3/8
750	30	98	3 7/8	67	2 5/8	79	3 1/8
900	36	95	3 3/4	57	2 1/4	73	2 7/8
1050	42	92	3 5/8	NA	NA	67	2 5/8
1200	48	89	3 1/2	NA	NA	60	2 3/8

Shading indicates preferred spring option.

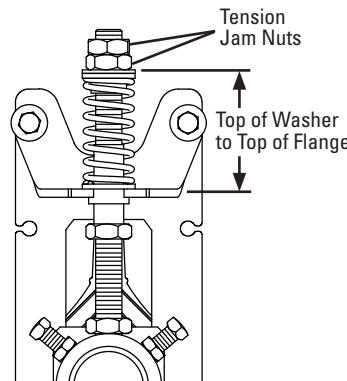

Pull-Up Tensioner Configuration (SD)

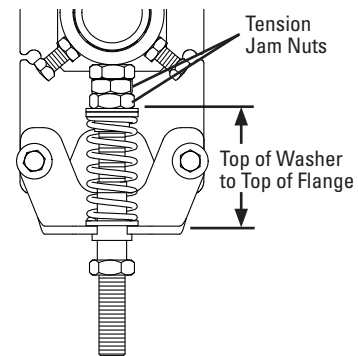

Push-Up Tensioner Configuration (SD)

Specifications:

- Maximum Belt Speed.....3M/sec (600 FPM)
- Temperature Rating.....-35°C to 82°C (-30°F to 180°F)
- Usable Blade Wear Length.....50mm (2") (Polyurethane)
6mm (1/4") (Carbide)
- Blade Materials.....**Purple:** Polyurethane (proprietary blend for abrasion resistance and long wear)
Carbide: Tungsten Carbide
- Available for Belt Widths.....450 to 1200mm (18" to 48"). Other sizes available upon request.
- CEMA Cleaner Rating.....Class 2 (Standard-duty with polyurethane blades)
Class 3 (Standard-duty with carbide blades)

Specifications & Guidelines

Y-Type™ Heavy Duty Secondary Cleaner with HD Carbide or Urethane Blades

Pole Length Specifications

Cleaner Size		Pole Length		Maximum Conveyor Span	
mm	in.	mm	in.	mm	in.
900	36	2286	90	2083	82
1050	42	2438	96	2235	88
1200	48	2590	102	2388	94
1350	54	2743	108	2540	100
1500	60	2895	114	2692	106
1800	72	3200	126	2997	118

Pole Length - Belt +1350mm (54")
Pole Diameter - 73mm (2-7/8")

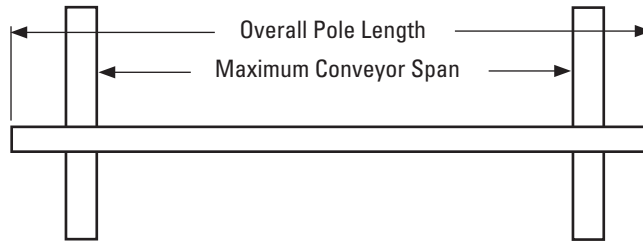

Clearance Guidelines for Installation

Cleaner Type	Belt Width/ Cleaner Size		Horizontal Clearance Required		Vertical Clearance Required	
	mm	in.	mm	in.	mm	in.
Y-Type® HD Polyurethane	900 - 1800	36 - 72	133	5-1/4	241	9-1/2
Y-Type HD Carbide	900 - 1800	36 - 72	133	5-1/4	248	9-3/4

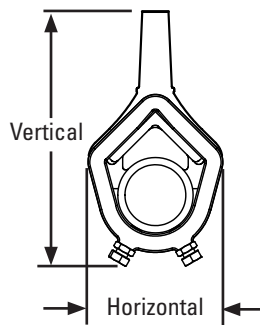

Y-Type Blade Specifications

Cushion	Durometer	Temperature Range
Purple (Standard)	86A	-35° to 82° C -30° to 180° F
Carbide	86	-35° to 82° C -30° to 180° F

‡ All ingredients used in the polyurethane formulation of this blade comply with the relevant requirements of 21 CFR (FDA Code of Federal Regulations) for use in repeated bulk dry food applications

Blade Width		Carbide Tip				Polyurethane Tip			
		Silver Springs		Black Springs		Green Springs		Blue Springs	
mm	in.	mm	in.	mm	in.	mm	in.	mm	in.
900	36	98	3 7/8	102	4	76	3	86	3 3/8
1050	42	95	3 3/4	98	3 7/8	73	2 7/8	83	3 1/4
1200	48	92	3 5/8	95	3 3/4	67	2 5/8	79	3 1/8
900	54	89	3 1/2	95	3 3/4	64	2 1/2	76	3
1050	60	86	3 3/8	92	3 5/8	NA	NA	73	2 7/8
1200	72	83	3 1/4	89	3 1/2	NA	NA	64	2 1/2

Shading indicates preferred spring option.

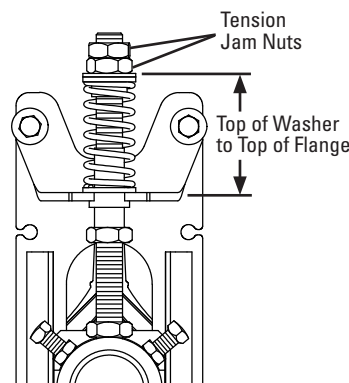

Pull-Up Tensioner Configuration (HD)

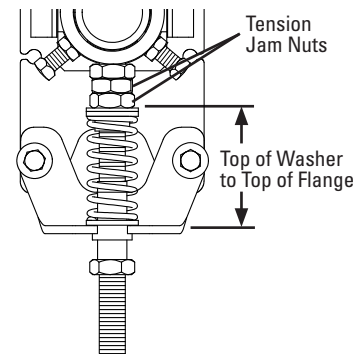

Push-Up Tensioner Configuration (HD)

Specifications:

- Maximum Belt Speed.....3.8M/sec (750 FPM)
- Temperature Rating.....-35°C to 82°C (-30°F to 180°F)
- Usable Blade Wear Length.....75mm (3") (Polyurethane)
10mm (3/8") (Carbide)
- Blade Materials.....**Purple:** Polyurethane (proprietary blend for abrasion resistance and long wear)
Carbide: Tungsten Carbide
- Available for Belt Widths.....900 to 1800mm (36" to 72"). Other sizes available upon request.
- CEMA Cleaner Rating.....Class 3 (Heavy-duty with polyurethane or carbide blades)

Replacement Parts List

Y-Type™ Standard Duty Secondary Cleaner with Carbide or Polyurethane Blades

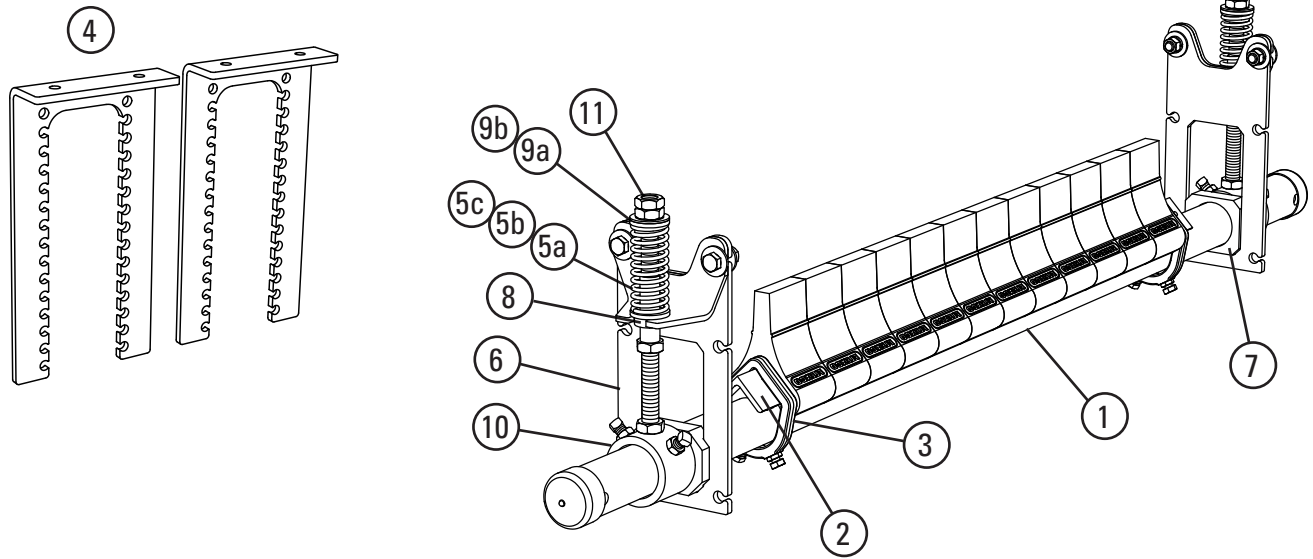

Replacement Parts

REF	DESCRIPTION	ORDERING NUMBER	ITEM CODE	WT. KG.
1	450mm (18") Y-Type™ Pole	YTP-18/450	82932	9.2
	600mm (24") Y-Type Pole	YTP-24/600	82933	10.3
	750mm (30") Y-Type Pole	YTP-30/750	82934	11.5
	900mm (36") Y-Type Pole	YTP-36/900	82935	12.6
	1050mm (42") Y-Type Pole	YTP-42/1050	82936	13.7
	1200mm (48") Y-Type Pole	YTP-48/1200	82937	14.9
2	450mm (18") Y-Type Cushion Angle	YTA-18/450	82949	2.6
	600mm (24") Y-Type Cushion Angle	YTA-24/600	82950	3.3
	750mm (30") Y-Type Cushion Angle	YTA-30/750	82951	4.0
	900mm (36") Y-Type Cushion Angle	YTA-36/900	82952	4.7
	1050mm (42") Y-Type Cushion Angle	YTA-42/1050	82953	5
	1200mm (48") Y-Type Cushion Angle	YTA-48/1200	82954	6.2
3	Y-Type Angle Clamp* (2 Clamps)	YTAC	79623	1.0
4	YST Drop Bracket Kit (2 Brackets)	YSTDBK	79844	9.0
5a	YST Spring Yellow	YSTS-Y	79795	0.1
5b	YST Spring Purple	YSTS-P	79796	0.2
5c	YST Spring Silver (Y-Type Carbide Cleaners)	CTS-S	77743	0.2
6	YST Mounting Bracket (incl. Angle Bracket)	YSTMB	79843	1.5
7	YST Guide Block Kit (Pair)	YSTGBK	79845	0.2
8	YST Lower Bushing Kit (Pair)	YSTLBK	79846	0.0
9a	YST Top Bushing Kit White (Pair)	YSTTBK-W	79847	0.0
9b	YST Top Bushing Kit Black (Pair)	YSTTBK-B	79855	0.0
10	YST Pole Mount Kit*	YSTPMK	79848	2.0
11	YST Adjusting Rod Nut Kit	YSTANK	79857	0.1

*Hardware included
Lead time: 2 weeks

Replacement Parts

REF	DESCRIPTION	ORDERING NUMBER	ITEM CODE	WT. KG.
-	YST Tensioner w/Yellow Spring (Pair) (incl. 2 ea. item 5a, 6, 10, 11; 1 ea. items 7, 8, 9a)	YST-Y	79836	8.3
-	YST Tensioner w/Purple Spring (Pair) (incl. 2 ea. item 5b, 6, 10, 11; 1 ea. items 7, 8, 9a)	YST-P	79837	8.4
-	YST Tensioner w/Silver Spring (Pair) (incl. 2 ea. item 5c, 6, 10, 11; 1 ea. items 7, 8, 9b)	YST-S	79838	8.5
-	P Adjusting Bracket	PAB	75513	1.0
-	P Pole Clamp	PCB	75507	3.0
-	P Mounting Bracket Repair Kit (includes left or right mounting bracket)	PMBL (left) PMBR (right)	75516 75519	3.8 3.8
-	P/R/I Mounting Kit (includes 2 each items PMB, PAB, PCB)	P/RMK	73025	12

Lead time: 2 weeks

Blades Required per Cleaner Size

mm	450	600	750	900	1050	1200
in.	18	24	30	36	42	48
Blades Required	6	8	10	12	14	16

Spring Tensioner Selection Chart

Cleaner Blade Width	79838 YST-S	79836 YST-Y	79837 YST-P
Carbide 450 - 1200mm (18" - 48")	X		
Polyurethane 450 - 750mm (18" - 30")		X	
Polyurethane 900 - 1200mm (36" - 48")			X

Stock items (non-shaded) refer to (*) for specific lead time, if not specified, standard lead time applies.

Non-stock items (shaded) please contact Flexco for dispatch options and lead times.

Replacement Parts List

Y-Type™ Heavy Duty Secondary Cleaner with HD Carbide or Urethane Blades

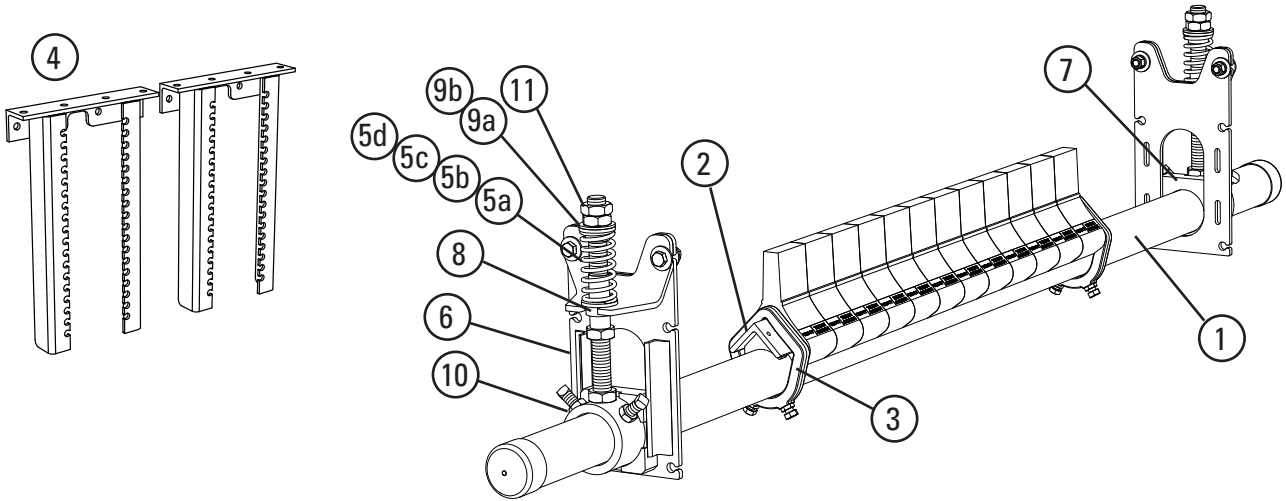

Replacement Parts

REF	DESCRIPTION	ORDERING NUMBER	ITEM CODE	WT. KG.
1	900mm (36") Y-Type™ HD Pole	YTPHD-36/900	83106	27.3
	1050mm (42") Y-Type HD Pole	YTPHD-42/1050	83107	28.8
	1200mm (48") Y-Type HD Pole	YTPHD-48/1200	83108	30.4
	1350mm (54") Y-Type HD Pole	YTPHD-54/1350	83109	31.9
	1500mm (60") Y-Type HD Pole	YTPHD-60/1500	83110	33.5
	1800mm (72") Y-Type HD Pole	YTPHD-72/1800	83112	35.0
2	900mm (36") Y-Type HD Cushion Angle	YTAHD-36/900	79805	7.5
	1050mm (42") Y-Type HD Cushion Angle	YTAHD-42/1050	79806	8.6
	1200mm (48") Y-Type HD Cushion Angle	YTAHD-48/1200	79807	9.7
	1350mm (54") Y-Type HD Cushion Angle	YTAHD-54/1350	79808	10.9
	1500mm (60") Y-Type HD Cushion Angle	YTAHD-60/1500	79809	12.0
	1800mm (72") Y-Type HD Cushion Angle	YTAHD-72/1800	79810	14.2
3	Y-Type HD Angle Clamp* (2 Clamps)	YTACHD	79835	2.2
4	YST HD Drop Bracket Kit (2 Brackets)	YSTDDBK	79850	14.6
5a	YST HD Spring, Green	YSTDHS-GR	79797	0.2
5b	SST Spring, Silver	STS-S	75843	0.4
5c	YST HD Spring, Blue (for Y-Type HD Carbide Cleaners)	YSTDHS-BL	79798	0.3
5d	SST Spring, Black (for Y-Type HD Carbide Cleaners)	STS-B	75844	0.5
6	YST HD Mounting Bracket	YSTDHMB	79849	3.0
7	YST HD Guide Block Kit (Pair)	YSTDGBK	79851	0.5
8	YST HD Lower Bushing Kit (Pair)	YSTDHLBK	79852	0.0
9a	YST HD Top Bushing Kit White (Pair)	YSTDHBK-W	79853	0.0
9b	YST HD Top Bushing Kit Black (Pair)	YSTDHBK-B	79856	0.0
10	YST HD Pole Mount Kit*	YSTPHDMK	79854	3.5
11	YST Adjusting Rod Nut Kit	YSTANK	79858	0.1

*Hardware included

Replacement Parts

REF	DESCRIPTION	ORDERING NUMBER	ITEM CODE	WT. KG.
-	YST Tensioner w/Silver Spring (Pair) (for belts 36" - 54" w/carbide tips) (incl. 2 ea. item 5b, 6, 10, 11; 1 ea. items 7, 8, 9a)	YSTHD-S	79840	15.2
-	YST Tensioner w/Black Spring (Pair) (for belts 60" - 72" w/carbide tips) (incl. 2 ea. item 5d, 6, 10, 11; 1 ea. items 7, 8, 9b)	YSTHD-BK	79842	15.5
-	YST Tensioner w/Green Spring (Pair) (for belts 36" - 48" w/Polyurethane tips) (incl. 2 ea. item 5a, 6, 10, 11; 1 ea. items 7, 8, 9a)	YSTHD-GR	79839	14.9
-	YST Tensioner w/Blue Spring (Pair) (for belts 54" - 72" w/Polyurethane tips) (incl. 2 ea. item 5c, 6, 10, 11; 1 ea. items 7, 8, 9b)	YSTHD-BL	79841	15.0
-	P Adjusting Bracket	PAB	75513	1.0
-	P Pole Clamp	PHDCB	75510	4.0
-	P Mounting Bracket Repair Kit (includes left or right mounting bracket)	PMBL (left) PMBR (right)	75516 75519	3.8 3.8
-	P/R/I Mounting Kit (includes 2 each items PMB, PAB, PHDCB)	PIHMK	73160	14

Blades Required per Cleaner Size

mm	900	1050	1200	1350	1500	1800
in.	36	42	48	54	60	72
Blades Required	12	14	16	18	20	24

Spring Tensioner Selection Chart

Cleaner Blade Width	Silver YSTDH-S	Black YSTDH-BK	Green YSTDH-GR	Blue YSTDH-BL
Carbide 900 - 1350mm (36" - 54")	X			
Carbide 1500 - 1800mm (60" - 72")		X		
Polyurethane 900 - 1200mm (36" - 48")			X	
Polyurethane 1350 - 1800mm (54" - 72")				X

Stock items (non-shaded) refer to (*) for specific lead time, if not specified, standard lead time applies.

Non-stock items (shaded) please contact Flexco for dispatch options and lead times.

Product Ordering Information

P-Type® Secondary Cleaner

P-Type® Secondary with V-Tips* Powder Coated

BELT WIDTH mm	ORDERING NUMBER	ITEM CODE	WT. KG.
450	PV450	73435	36.0
600	PV600	73004	37.0
750	PV750	73006	38.0
900	PV900	73008	41.0
1050	PV1050	73010	47.0
1200	PV1200	73012	51.0
1400	PV1400	73436	55.0
1500	PV1500	73437	58.0
1800	PVHD1800	74598	92.0
2000	PVHD2000	75452	96.0
2100	PVHD2100	74553	100.0
2400	PVHD2400	74555	110.0

*NOTE: V-Tips can be used ONLY on vulcanised belts. P-Type cleaners come standard with bolt tensioners. Shaded items are made to order-contact Flexco customer service.



P-Type® Secondary with V-Tips* Stainless Steel

BELT WIDTH mm	ORDERING NUMBER	ITEM CODE	WT. KG.
450	PV450-S/S	75323	37.0
600	PV600-S/S	75324	38.0
750	PV750-S/S	75325	39.0
900	PV900-S/S	75326	42.0
1050	PV1050-S/S	75327	48.0
1200	PV1200-S/S	75328	52.0
1400	PV1400-S/S	75329	56.0
1500	PV1500-S/S	75330	60.0
1800	PVHD1800-S/S	A1603	95.0
2000	PVHD2000-S/S	A2046	99.0
2100	PVHD2100-S/S	A1604	103.0
2400	PVHD2400-S/S	A1605	114.0

*NOTE: V-Tips can be used ONLY on vulcanised belts. P-Type cleaners come standard with bolt tensioners. Shaded items are made to order-contact Flexco customer service.

Tips Required Per Cleaner Size

BELT WIDTH mm	BLADE COVERAGE mm	V-TIPS REQUIRED
450	450	3
600	600	4
750	750	5
900	900	6
1050	1050	7
1200	1200	8
1400	1350	9
1500	1500	10
1800	1800	12
2000	1950	13
2100	2100	14
2400	2400	16

Product Notes:

- C-Tip: specially formulated tungsten carbide blades to work with mechanical fasteners.
- V-Tip: for use on vulcanised belts only.
- Compact design: fits in small transfer areas and tight chutes.

Stock items (non-shaded) refer to (*) for specific lead time, if not specified, standard lead time applies.

Non-stock items (shaded) please contact Flexco for dispatch options and lead times.

Replacement Parts List

P-Type®
Secondary Cleaner

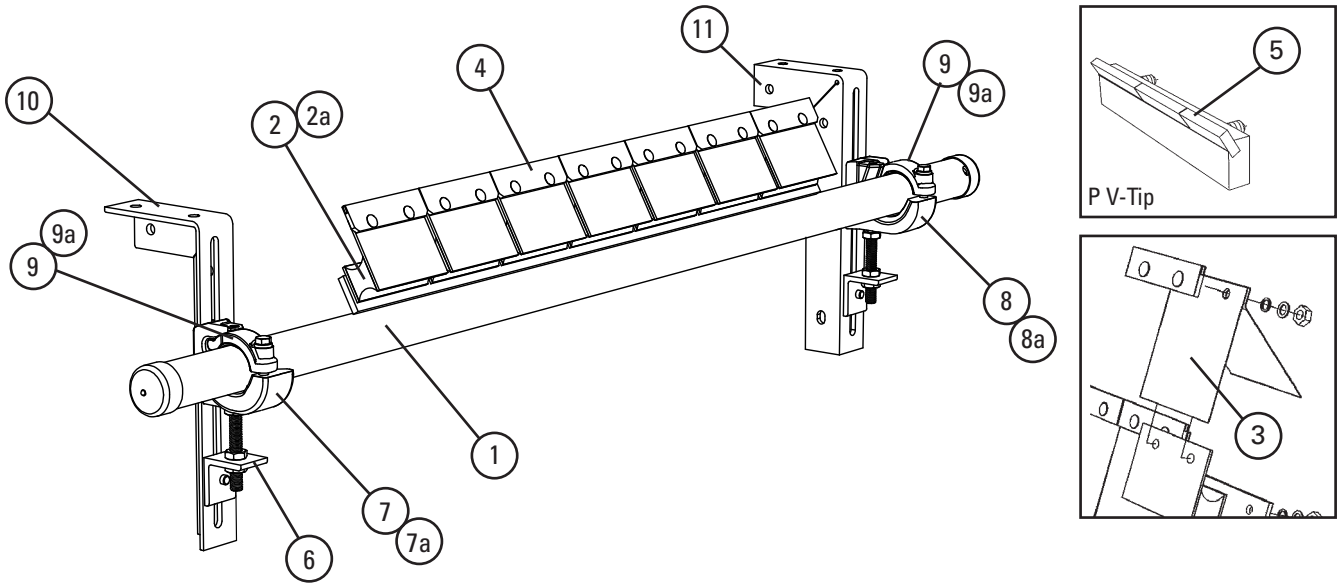

Replacement Parts

REF	DESCRIPTION	POWDER COATED					STAINLESS STEEL		
		BELT WIDTH	POLE LENGTH (MM)	ORDERING NUMBER	ITEM CODE	WT. KG.	ORDERING NUMBER	ITEM CODE	WT. KG.
1	P-Type® Pole 60 mm Pole Diameter	450	1250	PP450	73003	10.0	PP450-S/S	75382	10.0
		600	1350	PP600	73005	11.0	PP600-S/S	75383	11.0
		750	1500	PP750	73007	13.0	PP750-S/S	75384	13.0
		900	1650	PP900	73009	15.0	PP900-S/S	75385	15.0
		1050	1800	PP1050	73011	20.0	PP1050-S/S	75386	21.0
	P-Type Pole 73 mm Pole Diameter	1200	1950	PP1200	73013	20.0	PP1200-S/S	75387	23.0
		1400	2200	PP1400	73015	24.0	PP1400-S/S	75388	25.0
		1500	2350	PP1500	73016	25.0	PP1500-S/S	75389	26.0
		1800	2650	PPHD1800	74597	27.0	PPHD1800-S/S	A1781	28.0
		2000	2850	PPHD2000	74556	31.0	PPHD2000 -S/S	A2120	29.0
	2100	2950	PPHD2100	A2803	38.0	PPHD2100 -S/S	A1613	39.0	
	2400	3250	PPHD2400	74557	44.0	PPHD2400 -S/S	A1775	45.0	
2	P Cushion			PHA	73626	1.0	PHSC-S/S	73433	1.0
2a	P-Type Powerflex Cushion						PFC-P-S/S	79289	1.9
3	P Polyshield			PPS6	73024	1.0	PSSS	74773	1.0
-	PU-Tip (Polyurethane Tip for Fastened Belts)			PU150	73020	1.0			
4	C-Tip (for mechanically spliced and vulcanised belts)			CT6	74535	0.4			
5	P V-Tip* (for vulcanised belts only)			PSA150	73156	0.4	PVT6-S/S	75420	0.4
6	Adjusting Bracket Kit* (1ea.)			PAB	75513	0.7	PAB-S/S	75515	0.7
7	Pole Clamp Kit Left* (1ea.) (incl. item 9) (for sizes 450-1200mm)			CCKL	79224	3.1	CCKL-S/S	79226	3.1
8	Pole Clamp Kit Right* (1ea.) (incl. item 9) (for sizes 450-1200mm)			CCKR	79228	3.1	CCKR-S/S	79230	3.1
9	Cradle Clamp Top Strap (1ea.) (for use on L or R Pole Clamp Kit)			CCKTS	79232	0.5	CCKTS-S/S	79234	0.5
10	Mounting Bracket Kit Left			PMBL (left)	75516	3.8	PMBL-S/S (left)	75518	3.8
11	Mounting Bracket Kit Right			PMBL (right)	75519	3.8	PMBL-S/S (right)	75521	3.8
-	Cradle Clamp Mounting Kit* (for sizes 450-1200mm) (incl. 2 ea. item 6, and 1 ea. Items 7, 8, 10 & 11)			CCMK	78919	15.0	CCMK-S/S	78921	15.0
HEAVY-DUTY COMPONENTS									
7a	HD Pole Clamp Kit Left* (1ea.) (incl. item 9a) (for sizes 1200-2400mm)			CCKHDL	79225	4.0	CCKHDL-S/S	79227	4.0
8a	HD Pole Clamp Kit Right* (1ea.) (incl. item 9a) (for sizes 1200-2400mm)			CCKHDR	79229	4.0	CCKHDR-S/S	79231	4.0
9a	HD Cradle Clamp Top Strap (1ea.) (for use on L or R HD Pole Clamp Kit)			CCKHDTS	79233	0.8	CCKHDTS-S/S	73235	0.8
-	HD Cradle Clamp Mounting Kit* (for sizes 1200-2400mm) (incl. 2 ea. item 6, and 1 ea. Items 7, 8, 10 & 11)			CCMKHD	78920	16.7	CCMKHD-S/S	78922	16.7

*Hardware included

Product Ordering Information

R-Type® Reversing Secondary Cleaner

R-Type® Reversing with V-Tips*

BELT WIDTH mm	ORDERING NUMBER	ITEM CODE	WT. KG.
450	RV450	74633	36.0
600	RV600	74634	37.0
750	RV750	74635	38.0
900	RV900	74636	41.0
1050	RV1050	74637	47.0
1200	RV1200	74638	51.0
1400	RV1400	74639	55.0
1500	RV1500	74640	28.0
1800	RVHD1800	74642	92.0
2000	RVHD2000	75463	94.0
2100	RVHD2100	74643	100.0
2400	RVHD2400	74644	110.0

*NOTE: V-Tips can be used ONLY on vulcanised belts. Shaded items are made to order-contact Flexco® customer service.



Stainless Steel R-Type® Reversing with V-Tips*

BELT WIDTH mm	ORDERING NUMBER	ITEM CODE	WT. KG.
450	RV450-S/S	75341	37.0
600	RV600-S/S	75342	38.0
750	RV750-S/S	75343	39.0
900	RV900-S/S	75344	42.0
1050	RV1050-S/S	75345	48.0
1200	RV1200-S/S	75346	57.0
1400	RV1400-S/S	75347	56.0
1500	RV1500-S/S	75348	60.0
1800	RVHD1800-S/S	A1626	95.0
2100	RVHD2100-S/S	A1628	103.0
2400	RVHD2400-S/S	A1610	114.0

*NOTE: V-Tips can be used ONLY on vulcanised belts. Shaded items are made to order-contact Flexco customer service.

Tips Required Per Cleaner Size

BELT WIDTH mm	BLADE COVERAGE mm	C-TIPS OR V-TIPS REQUIRED
450	450	3
600	600	4
750	750	5
900	900	6
1050	1050	7
1200	1200	8
1500	1500	10
1800	1800	12
2000	1950	13
2100	2000	14
2400	2400	16

Product Notes:

- Two-way cushions allow cleaning in both directions.
- Tungsten carbide tips for long wear and superior cleaning.

Stock items (non-shaded) refer to (*) for specific lead time, if not specified, standard lead time applies.

Non-stock items (shaded) please contact Flexco for dispatch options and lead times.

Replacement Parts List

R-Type®
Reversing Secondary Cleaner

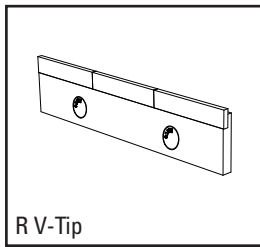
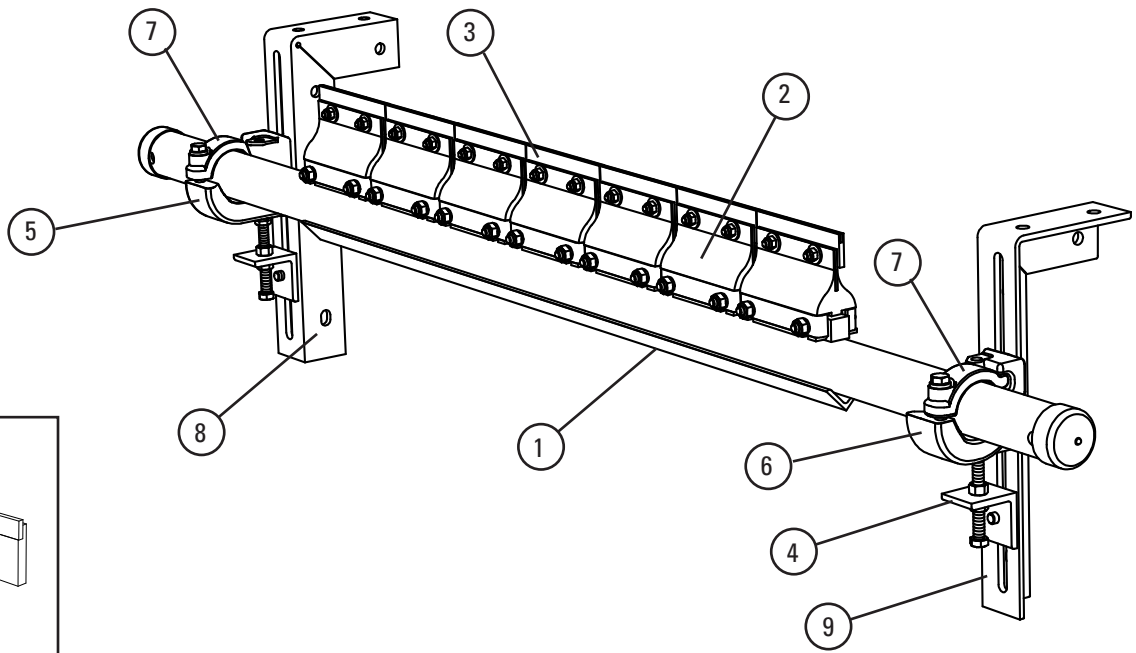

Replacement Parts

REF	DESCRIPTION	POWDER COATED					STAINLESS STEEL		
		BELT WIDTH	POLE LENGTH (MM)	ORDERING NUMBER	ITEM CODE	WT. KG.	ORDERING NUMBER	ITEM CODE	WT. KG.
1	R-Type® Pole 60 mm Pole Diameter	450	1250	RP450	74604	10.0	RP450-S/S	75400	10.0
		600	1350	RP600	74605	11.0	RP600-S/S	75401	11.0
		750	1500	RP750	74606	13.0	RP750-S/S	75402	13.0
		900	1650	RP900	74607	15.0	RP900-S/S	75403	15.0
		1050	1800	RP1050	74608	20.0	RP1050-S/S	75404	21.0
		1200	1950	RP1200	74609	22.0	RP1200-S/S	75405	23.0
	R-Type Pole 73 mm Pole Diameter	1400	2200	RP1400	74610	24.0	RP1400-S/S	75406	25.0
		1500	2350	RP1500	74611	25.0	RP1500-S/S	75407	26.0
		1800	2650	RPHD1800	74613	27.0	RPHD1800-S/S	A1575	28.0
		2000	2850	RPHD2000	74614	31.0	RPHD2000-S/S	61270	29.0
	2100	2950	RPHD2100	A2527	38.0	RPHD2100-S/S	A1629	39.0	
	2400	3250	RPHD2400	74615	44.0	RPHD2400-S/S	61271	45.0	
2	R Cushion			RSA	76249	1.0	RC-S/S	76250	1.0
3	R - V-Tip (for vulcanised belts only)			RSA150	73628	0.4	RVT6-S/S	76205	0.4
-	C-Tip (for mechanically spliced and vulcanised belts)			CT6	74535	0.4			
4	Adjusting Bracket Kit* (1ea.)			PAB	75513	0.7	PAB-S/S	75515	0.7
5	Pole Clamp Kit Left* (1ea.) (incl. item 9) (for sizes 450-1200mm)			CCKL	79224	3.1	CCKL-S/S	79226	3.1
6	Pole Clamp Kit Right* (1ea.) (incl. item 9) (for sizes 450-1200mm)			CCKR	79228	3.1	CCKR-S/S	79230	3.1
7	Cradle Clamp Top Strap (1ea.) (for use on L or R Pole Clamp Kit)			CCKTS	79232	0.5	CCKTS-S/S	79234	0.5
9	Mounting Bracket Kit Left			PMBL (left)	75516	3.8	PMBL-S/S (left)	75518	3.8
9	Mounting Bracket Kit Right			PMBL (right)	75519	3.8	PMBL-S/S (right)	75521	3.8
-	Cradle Clamp Mounting Kit* (for sizes 450-1200mm) (incl. 2 ea. item 6, and 1 ea. items 7, 8, 10 & 11)			CCMK	78919	15.0	CCMK-S/S	78921	15.0
Heavy-Duty Components									
-	HD Pole Clamp Kit Left* (1ea.) (incl. item 9a) (for sizes 1200-2400mm)			CCKHDL	79225	4.0	CCKHDL-S/S	79227	4.0
-	HD Pole Clamp Kit Right* (1ea.) (incl. item 9a) (for sizes 1200-2400mm)			CCKHDR	79229	4.0	CCKHDR-S/S	79231	4.0
-	HD Cradle Clamp Top Strap (1ea.) (for use on L or R HD Pole Clamp Kit)			CCKHDTS	79233	0.8	CCKHDTS-S/S	73235	0.8
-	HD Cradle Clamp Mounting Kit* (for sizes 1200-2400mm) (incl. 2 ea. item 6, and 1 ea. items 7, 8, 10 & 11)			CCMKHD	78920	16.7	CCMKHD-S/S	78922	16.7

*Hardware included
For additional sizes contact Flexco®.

Product Ordering Information

FMS Heavy-Duty Secondary Cleaner (MST Tensioners)



FFMS Secondary with V-Tips (MST)

BELT WIDTH		ORDERING NUMBER	ITEM CODE	WT. KG.
mm	in.			
600	24	FMS-600V	79647	44.4
750	30	FMS-750V	79648	49.3
900	36	FMS-900V	79649	54.3
1050	42	FMS-1050V	79650	59.2
1200	48	FMS-1200V	79651	64.1
1350	54	FMS-1350V	79652	69.0
1500	60	FMS-1500V	79653	73.9
1800	72	FMS-1800V	79654	83.6

For 2100mm and 2400mm options, please contact Flexco for pricing and availability
Lead time 3 weeks

FMS Secondary with V-Tips (MST) Stainless Steel

BELT WIDTH		ORDERING NUMBER	ITEM CODE	WT. KG.
mm	in.			
600	24	FMS-600V-S/S	66106	44.9
750	30	FMS-750V-S/S	66107	49.8
900	36	FMS-900V-S/S	66108	54.8
1050	42	FMS-1050V-S/S	66109	59.7
1200	48	FMS-1200V-S/S	66110	64.6
1350	54	FMS-1350V-S/S	66111	69.5
1500	60	FMS-1500V-S/S	66112	74.4
1800	72	FMS-1800V-S/S	66113	84.1

For 2100mm and 2400mm options, please contact Flexco for pricing and availability
Lead time 3 weeks

FMS Secondary with EL V-Tips (MST)

BELT WIDTH		ORDERING NUMBER	ITEM CODE	WT. KG.
mm	in.			
600	24	FMS-600-EL15	65660	44.4
750	30	FMS-750-EL15	65661	49.3
900	36	FMS-900-EL15	65662	54.3
1050	42	FMS-1050-EL15	65663	59.2
1200	48	FMS-1200-EL15	65664	64.1
1350	54	FMS-1350-EL15	65665	69.0
1500	60	FMS-1500-EL15	65666	73.9
1800	72	FMS-1800-EL15	65667	83.6

For 2100mm and 2400mm options, please contact Flexco for pricing and availability
Lead time 3 weeks

FMS Secondary with EL V-Tips (MST) Stainless Steel

BELT WIDTH		ORDERING NUMBER	ITEM CODE	WT. KG.
mm	in.			
600	24	FMS-600-EL15-S/S	65670	44.9
750	30	FMS-750-EL15-S/S	65671	49.8
900	36	FMS-900-EL15-S/S	65672	54.8
1050	42	FMS-1050-EL15-S/S	65673	59.7
1200	48	FMS-1200-EL15-S/S	65674	64.6
1350	54	FMS-1350-EL15-S/S	65675	69.5
1500	60	FMS-1500-EL15-S/S	65676	74.4
1800	72	FMS-1800-EL15-S/S	65677	84.1

For 2100mm and 2400mm options, please contact Flexco for pricing and availability
Lead time 3 weeks

Replacement Tips

ORDERING NUMBER	ITEM CODE	WT. KG.
CT6	74535	0.4
RSA150	73628	0.4
RVT6-S/S	76205	0.4
RSA150-EL	61141	0.4

Tips Required Per Cleaner Size

mm	600	750	900	1050	1200	1350	1500	1800	2100	2400
in.	24	30	36	42	48	54	60	72	84	96
C-Tips or V-Tips Required	4	5	6	7	8	9	10	12	14	16

Stock items (non-shaded) refer to (*) for specific lead time, if not specified, standard lead time applies.

Non-stock items (shaded) please contact Flexco for dispatch options and lead times.

U.S. Patent No. 6,823,983; 7,093,706

Specifications & Guidelines

Pole Length Specifications*

CLEANER SIZE		BLADE WIDTH		POLE LENGTH		MAXIMUM CONVEYOR SPAN	
mm	in.	mm	in.	mm	in.	mm	in.
600	24	600	24	1350	54	1100	44
750	30	750	30	1500	60	1250	50
900	36	900	36	1650	66	1400	56
1050	42	1050	42	1800	72	1550	62
1200	48	1200	48	1950	78	1700	68
1350	54	1350	54	2100	84	1850	74
1500	60	1500	60	2350	96	2100	86
1800	72	1800	72	2650	108	2400	98

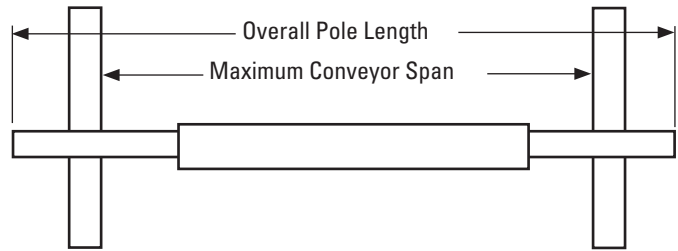

*For special extra long pole length requirements a Pole Extender Kit (#76024) is available that provides 750mm (30") of extended pole length. (page 127).

Pole Diameter - 73mm (2-7/8")

Clearance Guidelines for Installation

HORIZONTAL CLEARANCE REQUIRED		VERTICAL CLEARANCE REQUIRED	
mm	in.	mm	in.
89	3-1/2	245	10

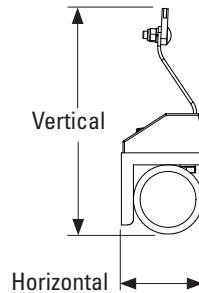

MST Tensioner Spring Length Chart

Blade Width		2 White Springs		2 Silver Springs		2 Black Springs	
mm	in.	mm	in.	mm	in.	mm	in.
600	24	67	2 5/8	86	3 3/8	89	3 1/2
750	30	60	2 3/8	83	3 1/4	86	3 3/8
900	36	54	2 1/8	79	3 1/8	83	3 1/4
1050	42	N/A	N/A	76	3	79	3 1/8
1200	48	N/A	N/A	73	2 7/8	79	3 1/8
1350	54	N/A	N/A	70	2 3/4	76	3
1500	60	N/A	N/A	70	2 3/4	73	2 7/8
1800	72	N/A	N/A	N/A	N/A	70	2 3/4

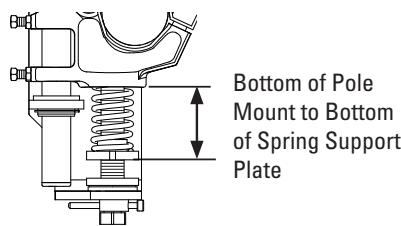

Shading indicates preferred spring option. Measure spring as shown.

Specifications

- Maximum Belt Speed5 m/s (1000 FPM)
- Temperature Rating-35°C to 82°C (-30°F to 180°F)
- Usable Blade Wear Length.....9mm (3/8")
- Blade MaterialsC-Tip: Impact Resistant Tungsten Carbide (works with mechanical fasteners)
.....V-Tip: Long Life Tungsten Carbide (for vulcanized belts only)
- Available for Belt Widths600 to 2400mm (24" to 96"). Other sizes available upon request
- CEMA Cleaner RatingClass 4

U.S. Patent No. 6,823,983; 7,093,706

Replacement Parts List

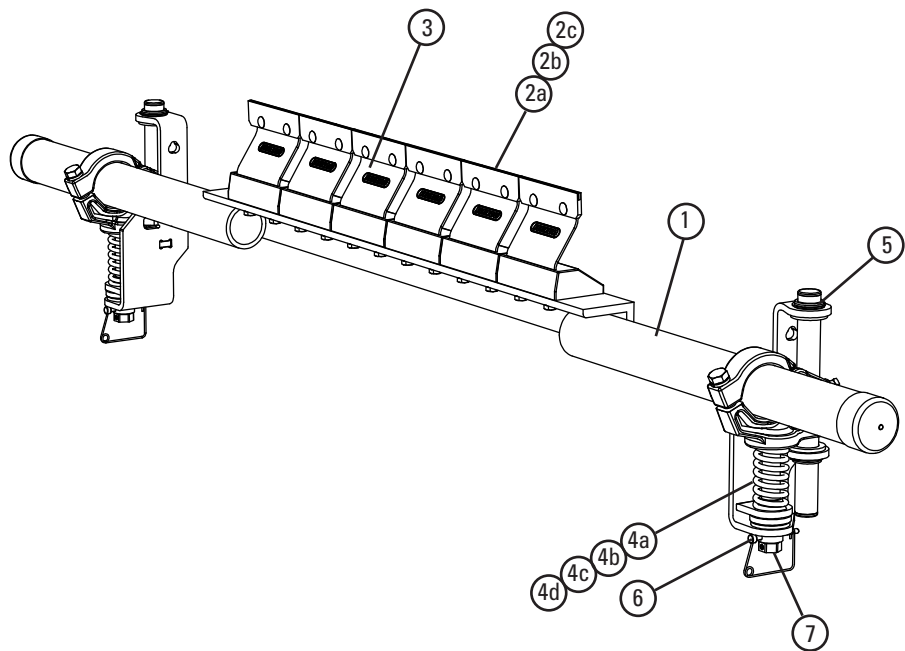

Replacement Parts

REF	DESCRIPTION		ORDERING NUMBER	ITEM CODE	WT. KG.	ORDERING NUMBER	ITEM CODE	WT. KG.
	Belt Width	Pole Length						
1	600	1350	MHS-P600*	77499	21.0	MHS-P600S/S*	77508	21.5
	750	1500	MHS-P750*	77500	23.5	MHS-P750S/S*	77509	24
	900	1650	MHS-P900*	77501	26.0	MHS-P900S/S*	77510	26.5
	1050	1800	MHS-P1050*	77502	28.5	MHS-P1050S/S*	77511	29
	1200	1950	MHS-P1200*	77527	31.0	MHS-P1200S/S*	77528	31.8
	1350	2100	MHS-P1350*	77503	33.5	MHS-P1350S/S*	77512	34.3
	1500	2350	MHS-P1500*	77504	36.0	MHS-P1500S/S*	77513	36.8
	1800	2650	MHS-P1800*	77505	38.5	MHS-P1800S/S*	77514	39.3
2a	R - V-Tip (for vulcanised belts only)		RSA150	73628	0.4	RVT6-S/S	76205	0.4
2b	C-Tip (for mechanically spliced and vulcanised belts)		CT6	74535	0.4			
2c	Extra Life R - V-Tip (15mm)		RSA150-EL	61141	0.4	RSA150-EL	61141	0.4
3	FMS Cushion Kit		FMSC	79699	1.9	FMSC	79699	1.9
4a	Tension Spring - White (1 ea.) for belts 450-750mm		STS-W	75846	0.2	STS-W-S/S	77630	0.2
4b	Tension Spring - Silver (1 ea.) for belts 900-1350mm		STS-S	75843	0.4	STS-S-S/S	77631	0.4
4c	Tension Spring - Black (1 ea.) for belts 1500-1800mm		STS-B	75844	0.5	STS-B-S/S	77632	0.5
4d	Tension Spring - Gold (1 ea.) for belts over 2100mm		STS-G	78142	0.5	STS-G-S/S	79057	0.5
5	MST Bushing Kit (incl. 4 bushings)		MSTBK	79440	0.1	MSTBK	79440	0.1
6	MST Lock Pin		MSTLP	64930	0.1	MSTLP	64930	0.1
7	MST Adjusting Mechanism		MSTAM	79435	0.5	MSTAM-S/S	64931	0.5
-	MST HD Tensioner w/White Spring		MSTHD-W	79431	16.7	MSTHD-W-S/S	90181	16.7
-	MST HD Tensioner w/Silver Spring		MSTHD-S	79432	17.0	MSTHD-S-S/S	90182	17.0
-	MST HD Tensioner w/Black Spring		MSTHD-B	79433	17.3	MSTHD-B-S/S	90183	17.3
-	MST HD Tensioner w/Gold Spring		MSTHD-G	63020	17.3	MSTHD-G-S/S	90184	17.3

For 2100mm and 2400mm options, please contact Flexco for pricing and availability
*Lead time 3 weeks

Stock items (non-shaded) refer to (*) for specific lead time, if not specified, standard lead time applies.
Non-stock items (shaded) please contact Flexco for dispatch options and lead times.

U.S. Patent No. 6,823,983; 7,093,706

Product Ordering Information

MHS - MST Heavy Duty Secondary Cleaner

MHS HD with MST Tensioner - Mild Steel

BELT WIDTH	ORDERING NUMBER	ITEM CODE	TIP WIDTH	POLE LENGTH	WT. KG.
mm			mm	mm	
600	MHS-600-MST	64020	600	1350	44.4
750	MHS-750-MST	64021	750	1500	49.3
900	MHS-900-MST	64022	900	1650	54.3
1050	MHS-1050-MST	64023	1050	1800	59.2
1200	MHS-1200-MST	64024	1200	1950	64.1
1350	MHS-1350-MST	64025	1350	2100	69
1500	MHS-1500-MST	64026	1500	2350	73.9
1800	MHS-1800-MST	64027	1800	2650	83.6
2100	MHS-2100-MST	64028	2100	3200	95.7
2400	MHS-2400-MST	64029	2400	3250	103.2

Lead time 3 weeks

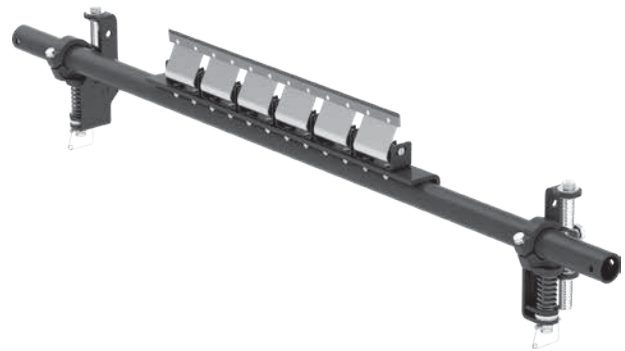

MHS HD with MST Tensioner - Stainless Steel

BELT WIDTH	ORDERING NUMBER	ITEM CODE	TIP WIDTH	POLE LENGTH	WT. KG.
mm			mm	mm	
600	MHS-600-MST-S/S	64030	600	1350	44.9
750	MHS-750-MST-S/S	64031	750	1500	49.8
900	MHS-900-MST-S/S	64032	900	1650	54.8
1050	MHS-1050-MST-S/S	64033	1050	1800	59.7
1200	MHS-1200-MST-S/S	64034	1200	1950	64.6
1350	MHS-1350-MST-S/S	64035	1350	2100	69.5
1500	MHS-1500-MST-S/S	64036	1500	2350	74.4
1800	MHS-1800-MST-S/S	64037	1800	2650	84.1
2100	MHS-2100-MST-S/S	64038	2100	3200	96.2
2400	MHS-2400-MST-S/S	64039	2400	3250	103.7

Lead time 3 weeks

Product Notes:

- Heavy-duty design to deliver maximum cleaning efficiency on the most demanding, abusive beltlines.
- Pole Length: Belt width plus 1350mm (54"). For longer requirements, see accessories - Pole Extender Kit (page 124).
- Patented PowerFlex™ cushion design to maintain continuous blade-to-belt contact and quick relief from passing mechanical splices.
- V-Tips are for vulcanized belts only.
- Visual Blade Tension Check: Measure the tension spring and refer to Spring Length Chart on mounting base for the correct length for best cleaning performance.
- Tensioner: MST Spring Tensioner for self-adjusting tensioning with easy retensioning adjustments.
- To make cleaner installation easier and quicker, see Optional Mounting Kits (page 124).

Stock items (non-shaded) refer to (*) for specific lead time, if not specified, standard lead time applies.

Non-stock items (shaded) please contact Flexco for dispatch options and lead times.

Replacement Parts List

MHS - MST Heavy Duty Secondary Cleaner

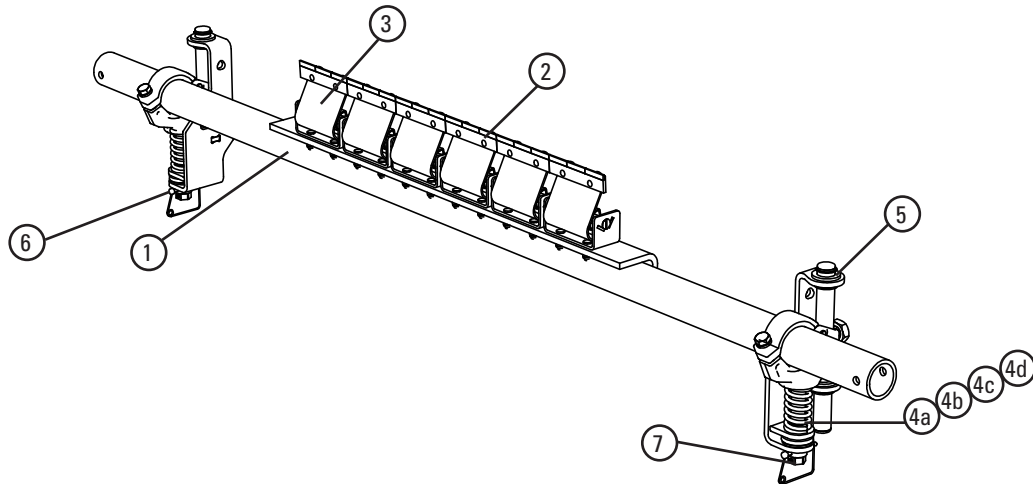

Replacement Parts

REF	DESCRIPTION		MILD STEEL			STAINLESS STEEL		
			ORDERING NUMBER	ITEM CODE	WT. KG.	ORDERING NUMBER	ITEM CODE	WT. KG.
	BELT WIDTH mm	POLE LENGTH mm						
1	600	1350	MHS-P600	77499	23.5	MHS-P600S/S	77508	24.0
	750	1500	MHS-P750	77500	26.0	MHS-P750S/S	77509	26.5
	900	1650	MHS-P900	77501	28.5	MHS-P900S/S	77510	29.0
	1050	1800	MHS-P1050	77502	31.0	MHS-P1050S/S	77511	31.7
	1200	1950	MHS-P1200	77527	33.5	MHS-P1200S/S	77528	34.3
	1350	2100	MHS-P1350	77503	36.0	MHS-P1350S/S	77512	36.8
	1500	2350	MHS-P1500	77504	38.5	MHS-P1500S/S	77513	39.3
	1800	2650	MHS-P1800	77505	43.5	MHS-P1800S/S	77514	44.4
	2100	3200	MHS-P2100	77506	51.0	MHS-P2100S/S	77515	52.0
	2400	3250	MHS-P2400	77507	58.0	MHS-P2400S/S	77516	59.3
2	C-Tip (suits mechanical fastened belt)		CT6	74535	.4	N/A	N/A	—
	V-Tip (suits vulcanised belt)		RSA150	73628	.4	RVT6-S/S	76205	.4
3	PowerFlex™ Cushion		SPFC	79200	2.0	SPFC-S/S	79201	2.0
4a	Tension Spring - White (1 ea.) for belts 450-750mm		STS-W	75846	0.2	STS-W-S/S	77630	0.2
4b	Tension Spring - Silver (1 ea.) for belts 900-1350mm		STS-S	75843	0.4	STS-S-S/S	77631	0.4
4c	Tension Spring - Black (1 ea.) for belts 1500-1800mm		STS-B	75844	0.5	STS-B-S/S	77632	0.5
4d	Tension Spring - Gold (1 ea.) for belts over 2100mm		STS-G	78142	0.5	STS-G-S/S	79057	0.5
5	MST Bushing Kit (incl. 4 bushings)		MSTBK	79440	0.1	MSTBK	79440	0.1
6	MST Lock Pin		MSTLP	64930	0.1	MSTLP	64930	0.1
7	MST Adjustment Mechanism		MSTAM	79435	0.5	MSTAM-S/S	64931	0.5
-	MST HD Tensioner w/White Spring		MSTHD-W	79431	16.7	MSTHD-SS-W	90181	16.7
-	MST HD Tensioner w/Silver Spring		MSTHD-S	79432	17.0	MSTHD-SS-S	90182	17.0
-	MST HD Tensioner w/Black Spring		MSTHD-B	79433	17.3	MSTHD-SS-B	90183	17.3
-	MST HD Tensioner w/Gold Spring		MSTHD-G	63020	17.3	MSTHD-SS-G	90184	17.3

MST Spring Tensioner Selection Chart

CLEANER SIZE	White Spring	Silver Spring	Black Spring	Gold Spring
MHS 450 - 750mm	X			
MHS 900 - 1350mm		X		
MHS 1500 - 1800mm			X	
MHS 1800 - 2400mm				X

Stock items (non-shaded) refer to (*) for specific lead time, if not specified, standard lead time applies.

Non-stock items (shaded) please contact Flexco for dispatch options and lead times.

Replacement Parts List

MHS - MST Heavy Duty Secondary Cleaner

ATV Replacement Parts

REF	DESCRIPTION	ORDERING NUMBER	ITEM CODE	WT. KG.
1	Mounting Bracket LH	PMBL-S/S	75518	3.8
2	Mounting Bracket RH	PMBR-S/S	75521	3.8
3	Air Tensioner Slider	ATV-SLIDE	62425	0.2
4	Air Tension Cradle Blocks 60mm Kit	ATV-MOUNT	62424	2.4
5	Air Tension Cradle Blocks 73mm Kit	ATV-MOUNT	63073	2.4
6	Air Tension Adjusting Angle	ATV-ANGLE	62426	1.0
7	Air Bag	ATV-BAG	62036	0.2
8	Hex Nut S/S	HEX NUT	G1211	0.1
9	Air Line Adaptor	ATV-NIP	62037	0.1
10	PAT Control Box 60psi	PACB60	78683	5.0
11	PAT Control Box 100psi	PACB100	79656	5.0
-	Secondary Air Tension 60mm Complete Kit	ATVK-60	62409	13.0
-	Secondary Air Tension 73mm Complete Kit	ATVK-73	63072	15.0

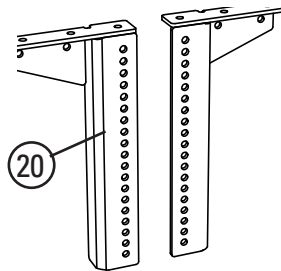
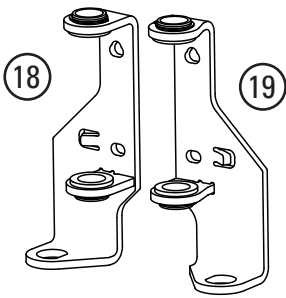
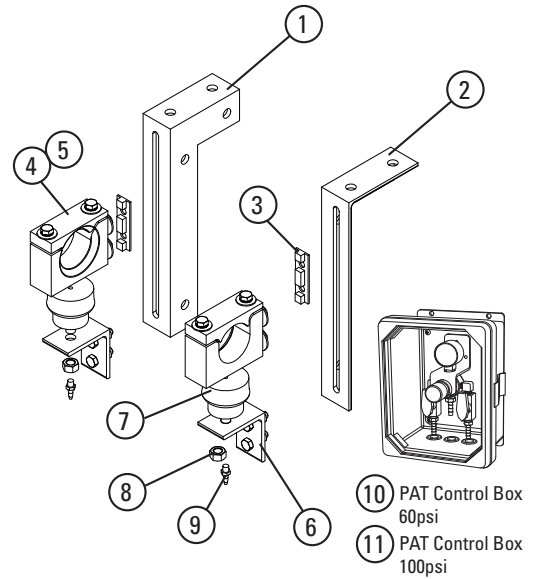

MST Tensioner Replacement Parts

REF	DESCRIPTION	ORDERING NUMBER	ITEM CODE	WT. KG.
18	MST Mounting Bracket LH (incl. bushings)	MST-MBL	79436	2.6
19	MST Mounting Bracket RH (incl. bushings)	MST-MBR	79437	2.6
20	MST Drop Brackets (2)	MSTDB	79434	12.6

*Hardware included

Shaded items are made to order. Lead time 3 weeks.

Stock items (non-shaded) refer to (*) for specific lead time, if not specified, standard lead time applies.

Non-stock items (shaded) please contact Flexco for dispatch options and lead times.

Product Ordering Information

MHS - BT Heavy Duty Secondary Cleaner



MHS HD with Bolt Tensioner (MHS-BT) Mild Steel

BELT WIDTH mm	ORDERING NUMBER	ITEM CODE	TIP WIDTH mm	POLE LENGTH mm	WT. KG.
600	MHS-600BTV	77481	600	1350	44.4
750	MHS-750BTV	77482	750	1500	49.3
900	MHS-900BTV	77483	900	1650	54.3
1050	MHS-1050BTV	77484	1050	1800	59.2
1200	MHS-1200BTV	77525	1200	1950	64.1
1350	MHS-1350BTV	77485	1350	2100	69.0
1500	MHS-1500BTV	77486	1500	2350	73.9
1800	MHS-1800BTV	77487	1800	2650	83.6
2100	MHS-2100BTV	77488	2100	3200	95.7
2400	MHS-2400BTV	77489	2400	3250	103.2

Lead time: 3 weeks

MHS HD with Bolt Tensioner (MHS-BT) Stainless Steel

BELT WIDTH mm	ORDERING NUMBER	ITEM CODE	TIP WIDTH mm	POLE LENGTH mm	WT. KG.
600	MHS-600BTV-S/S	77490	600	1350	45.3
750	MHS-750BTV-S/S	77491	750	1500	50.3
900	MHS-900BTV-S/S	77492	900	1650	55.3
1050	MHS-1050BTV-S/S	77493	1050	1800	60.4
1200	MHS-1200BTV-S/S	77526	1200	1950	65.4
1350	MHS-1350BTV-S/S	77494	1350	2100	70.4
1500	MHS-1500BTV-S/S	77495	1500	2350	75.4
1800	MHS-1800BTV-S/S	77496	1800	2650	85.3
2100	MHS-2100BTV-S/S	77497	2100	3200	97.6
2400	MHS-2400BTV-S/S	77498	2400	3250	105.3

Lead time: 3 weeks

Stock items (non-shaded) refer to (*) for specific lead time, if not specified, standard lead time applies.

Non-stock items (shaded) please contact Flexco for dispatch options and lead times.

Replacement Parts List

MHS - BT Heavy Duty Secondary Cleaner

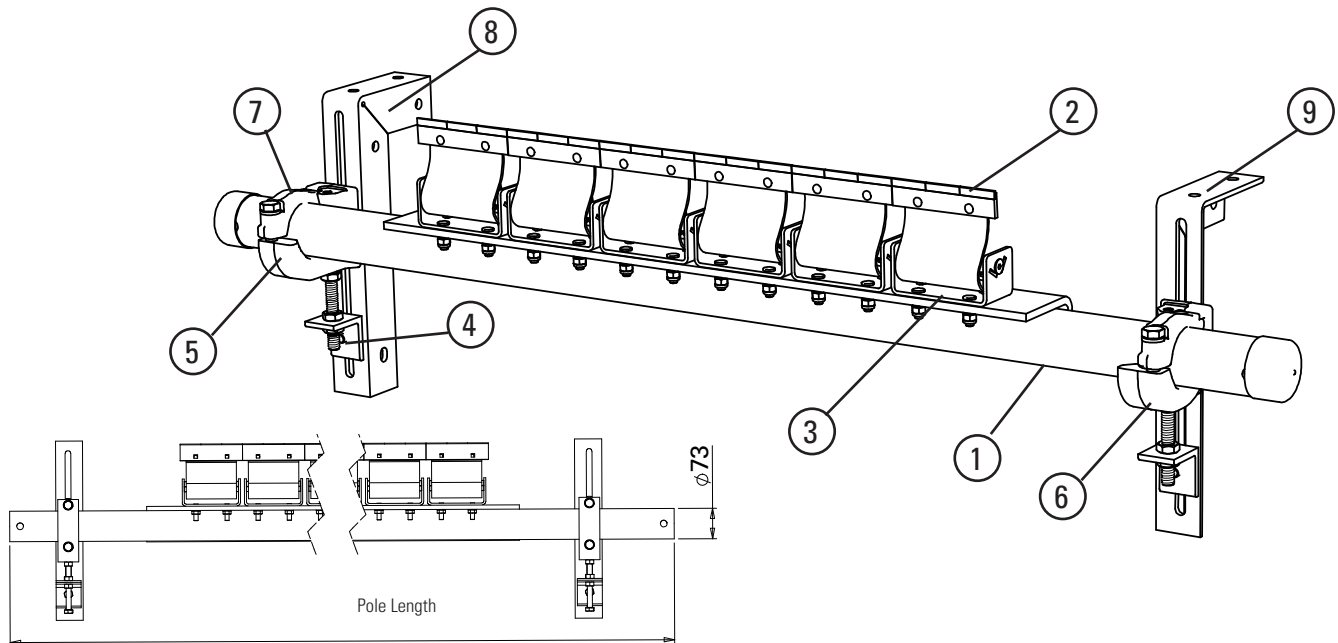

Replacement Parts

REF	DESCRIPTION		MILD STEEL			STAINLESS STEEL		
	BELT WIDTH mm	POLE LENGTH mm	ORDERING NUMBER	ITEM CODE	WT. KG.	ORDERING NUMBER	ITEM CODE	WT. KG.
1	600	1350	MHS-P600*	77499	21.0	MHS-P600S/S*	77508	21.5
	750	1500	MHS-P750*	77500	23.5	MHS-P750S/S*	77509	24.0
	900	1650	MHS-P900*	77501	26.0	MHS-P900S/S*	77510	26.5
	1050	1800	MHS-P1050*	77502	28.5	MHS-P1050S/S*	77511	29.0
	1200	1950	MHS-P1200*	77527	31.0	MHS-P1200S/S*	77528	31.8
	1350	2100	MHS-P1350*	77503	33.5	MHS-P1350S/S*	77512	34.3
	1500	2350	MHS-P1500*	77504	36.0	MHS-P1500S/S*	77513	36.8
	1800	2650	MHS-P1800*	77505	38.5	MHS-P1800S/S*	77514	39.3
	2100	3200	MHS-P2100*	77506	43.5	MHS-P2100S/S*	77515	44.5
	2400	3250	MHS-P2400*	77507	51.0	MHS-P2400S/S*	77516	52.0
2	R - V-Tip (for vulcanised belts only)		RSA150	73628	0.4	RVT6-S/S	76205	0.4
	C-Tip (for mechanically spliced and vulcanised belts)		CT6	74535	0.4			
3	PowerFlex™ Cushion		SPFC	79200	2.0	SPFC-S/S	79201	2.0
4	Adjusting Bracket Kit* (1ea.)		PAB	75513	0.7	PAB-S/S	75515	0.7
5	HD Pole Clamp Kit Left* (1ea.) (incl. item 9a) (for sizes 1200-2400mm)		CCKHDL	79225	4.0	CCKHDL-S/S	79227	4.0
6	HD Pole Clamp Kit Right* (1ea.) (incl. item 9a) (for sizes 1200-2400mm)		CCKHDR	79229	4.0	CCKHDR-S/S	79231	4.0
7	HD Cradle Clamp Top Strap (1ea.) (for use on L or R HD Pole Clamp Kit)		CCKHDTS	79233	0.8	CCKHDTS-S/S	73235	0.8
8	Mounting Bracket Kit Left		PMBL (left)	75516	3.8	PMBL-S/S (left)	75518	3.8
9	Mounting Bracket Kit Right		PMBL (right)	75519	3.8	PMBL-S/S (right)	75521	3.8
-	HD Cradle Clamp Mounting Kit* (for sizes 1200-2400mm) (incl. 2 ea. item 4, and 1 ea. items 5, 6, 8 & 9)		CCMKHD	78920	16.7	CCMKHD-S/S	78922	16.7

*Lead time: 3 weeks

Stock items (non-shaded) refer to (*) for specific lead time, if not specified, standard lead time applies.

Non-stock items (shaded) please contact Flexco for dispatch options and lead times.

Product Ordering Information

MHS - SST Heavy Duty Secondary Cleaner

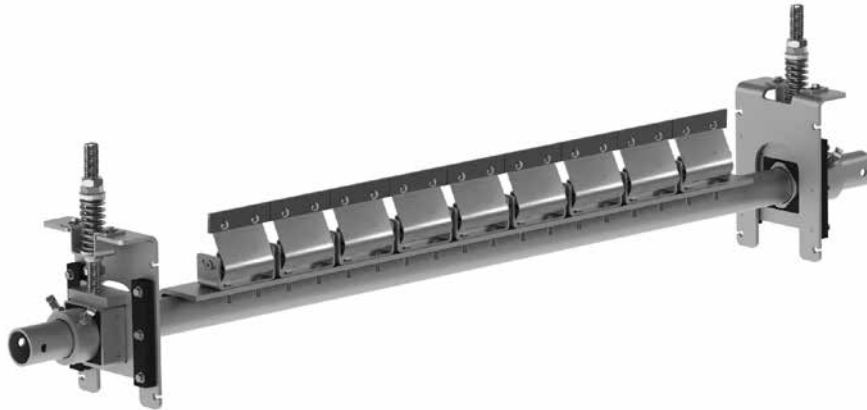

MHS HD with SST Spring Tensioner (Complete MHS-FP Cleaner-V Tips)

BELT WIDTH mm	TIP WIDTH mm	POLE LENGTH mm	MILD STEEL			STAINLESS STEEL		
			ORDERING NUMBER	ITEM CODE	WT. KG.	ORDERING NUMBER	ITEM CODE	WT. KG.
600	600	1350	MHS-600FPV	77789	56.8	MHS-600FPV-S/S	77799	58.0
750	750	1500	MHS-750FPV	77790	61.8	MHS-750FPV-S/S	77800	63.0
900	900	1650	MHS-900FPV	77791	67.0	MHS-900FPV-S/S	77801	68.3
1050	1050	1800	MHS-1050FPV	77792	71.8	MHS-1050FPV-S/S	77802	73.3
1200	1200	1950	MHS-1200FPV	77793	76.8	MHS-1200FPV-S/S	77803	78.3
1350	1350	2100	MHS-1350FPV	77794	81.5	MHS-1350FPV-S/S	77804	83.3
1500	1500	2350	MHS-1500FPV	77795	86.5	MHS-1500FPV-S/S	77805	88.3
1800	1800	2650	MHS-1800FPV	77796	96.5	MHS-1800FPV-S/S	77806	98.5
2100	2100	3200	MHS-2100FPV	77797	108.5	MHS-2100FPV-S/S	77807	110.8
2400	2400	3250	MHS-2400FPV	77798	125.0	MHS-2400FPV-S/S	77808	127.0

Lead time: 3 weeks

Stock items (non-shaded) refer to (*) for specific lead time, if not specified, standard lead time applies.

Non-stock items (shaded) please contact Flexco for dispatch options and lead times.

Replacement Parts List

MHS - SST Heavy Duty Secondary Cleaner

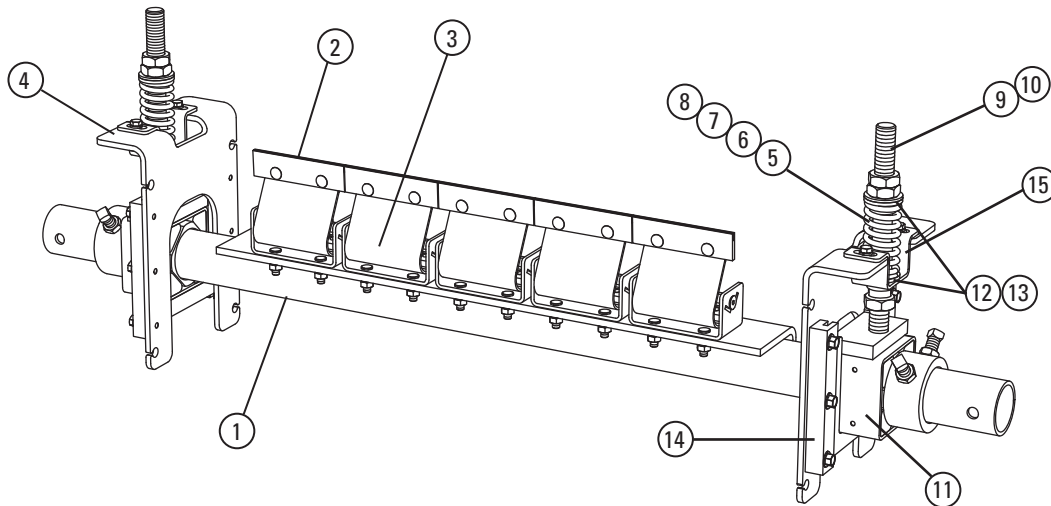

Replacement Parts

REF	DESCRIPTION		MILD STEEL			STAINLESS STEEL		
			ORDERING NUMBER	ITEM CODE	WT. KG.	ORDERING NUMBER	ITEM CODE	WT. KG.
	BELT WIDTH mm	POLE LENGTH mm						
1	600	1350	MHS-P600*	77499	23.5	MHS-P600S/S*	77508	24.0
	750	1500	MHS-P750*	77500	26.0	MHS-P750S/S*	77509	26.5
	900	1650	MHS-P900*	77501	28.5	MHS-P900S/S*	77510	29.0
	1050	1800	MHS-P1050*	77502	31.0	MHS-P1050S/S*	77511	31.7
	1200	1950	MHS-P1200*	77527	33.5	MHS-P1200S/S*	77528	34.3
	1350	2100	MHS-P1350*	77503	36.0	MHS-P1350S/S*	77512	36.8
	1500	2350	MHS-P1500*	77504	38.5	MHS-P1500S/S*	77513	39.3
	1800	2650	MHS-P1800*	77505	43.5	MHS-P1800S/S*	77514	44.4
	2100	3200	MHS-P2100*	77506	51.0	MHS-P2100S/S*	77515	52.0
	2400	3250	MHS-P2400*	77507	58.0	MHS-P2400S/S*	77516	59.3
2	C-Tip (suits mechanical fastened belt)		CT6	74535	.4	N/A	N/A	—
	V-Tip (suits vulcanised belt)		RSA150	73628	.4	RVT6-S/S	76205	.4
3	PowerFlex™ Cushion		SPFC	79200	2.0	SPFC-S/S	79201	2.0
4	SST HD® Mounting Base Kit* (includes 1 mounting base and 2 slide guides)		SSTHDMK	77870	4.6	STHDMK2-S/S	77634	4.6
5	SST Spring - White (1 ea.) for belts 450-750mm		STS-W	75846	0.2	STS-W-S/S	77630	0.2
6	SST Spring - Silver (1 ea.) for belts 900-1500mm		STS-S	75843	0.4	STS-S-S/S	77631	0.4
7	SST Spring - Black (1 ea.) for belts 1800-2100mm		STS-B	75844	0.5	STS-B-S/S	77632	0.5
8	SST Spring - Gold (1 ea.) for belts over 2100mm		STS-G	78142	0.7			
9	SST Adj Rod Kit* (incl. 1 rod, 2 nuts, 2 bushings, 1 washer) for belts 450-1500 mm		STAK	75847	1.3	STAK	75847	1.3
10	SST HD Adj Rod Kit* (incl. 1 rod, 2 nuts, 2 HD bushings, 1 washer) for belts 1800-2100mm		STAKHD	75892	1.4	STAKHD	75892	1.4
11	SST HD Torsion Pole Mount* (1 ea.)		SSTHDPM	77868	6.8	STHDPM2-S/S	77633	6.8
12	SST Bushing Kit - White/Silver		SSTBK-W	76636	0.1	SSTBK-W	76636	0.1
13	SST Bushing Kit - Black/Gold		SSTBK-B	76637	0.1	SSTBK-B	76637	0.1
14	ST Slide Guide Kit		STGK2	77635	0.5	STGK2	77635	0.5
-	SST HD Cartridge Tensioner - White (includes 1 ea. item 5, 9, 12, 14) for belts 450-750 mm		SST1HDM-W	78517	13.7	SST1HDM-W-S/S	78394	13.7
-	SST HD Cartridge Tensioner - Silver (includes 1 ea. item 6, 9, 12, 14) for belts 900-1500 mm		SST1HDM-S	78518	13.9	SST1HDM-S-S/S	78395	13.9
-	SST HD Cartridge Tensioner - Black (includes 1 ea. item 7, 10, 13, 14) for belts 1800-2100 mm		SST1HDM-B	78519	14.1	SST1HDM-B-S/S	78396	14.1
-	SST HD Cartridge Tensioner - Gold (includes 1 ea. item 8, 10, 13, 14) for belts over 2100 mm		SST1HDM-G	79069	14.3			
15	SST Hat Channel Kit		SSTHK	79070	0.7	SSTHK-S/S	79071	0.7

*Lead time: 3 weeks

Stock items (non-shaded) refer to (*) for specific lead time, if not specified, standard lead time applies.

Non-stock items (shaded) please contact Flexco for dispatch options and lead times.

Replacement Parts List

MHS - SST Heavy Duty Secondary Cleaner

ATV Replacement Parts

REF	DESCRIPTION	ORDERING NUMBER	ITEM CODE	WT. KG.
1	Mounting Bracket LH	PMBL-S/S	75518	3.8
2	Mounting Bracket RH	PMBR-S/S	75521	3.8
3	Air Tensioner Slider	ATV-SLIDE	62425	0.2
4	Air Tension Cradle Blocks 60mm Kit	ATV-MOUNT	62424	2.4
5	Air Tension Cradle Blocks 73mm Kit	ATV-MOUNT	63073	2.4
6	Air Tension Adjusting Angle	ATV-ANGLE	62426	1.0
7	Air Bag	ATV-BAG	62079	0.2
8	Hex Nut S/S	HEX NUT	G1211	0.1
9	Air Line Adaptor	ATV-NIP	62037	0.1
10	PAT Control Box 60psi	PACB60	78683	5.0
11	PAT Control Box 100psi	PACB100	79656	5.0
-	Secondary Air Tension 60mm Complete Kit	ATVK-60	62409	13.0
-	Secondary Air Tension 73mm Complete Kit	ATVK-73	63072	15.0

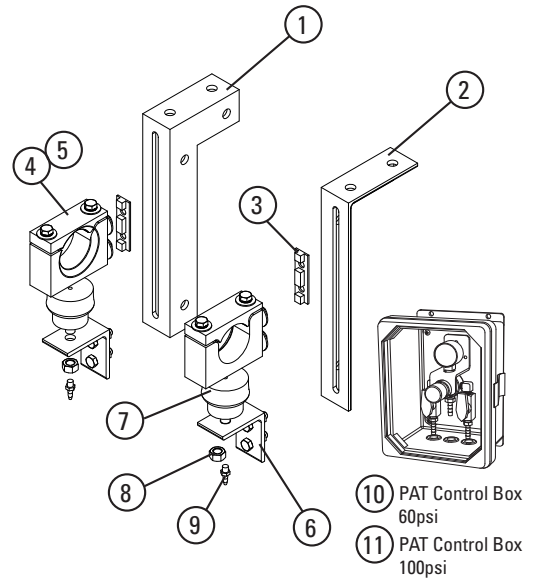

Stock items (non-shaded) refer to (*) for specific lead time, if not specified, standard lead time applies.

Non-stock items (shaded) please contact Flexco for dispatch options and lead times.

Specifications & Guidelines

MHS - SST Heavy Duty Secondary Cleaner

Clearance Guidelines for Installation

HORIZONTAL CLEARANCE REQUIRED mm	VERTICAL CLEARANCE REQUIRED mm
100	238

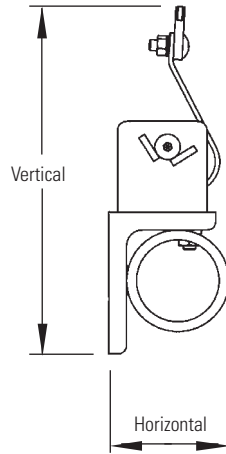

Spring Length Chart for SST Spring Tensioner

BLADE WIDTH mm	WHITE SPRINGS mm	SILVER SPRINGS mm	BLACK SPRINGS mm
450	80	100	N/A
600	70	90	N/A
750	70	90	N/A
900	N/A	90	90
1050	N/A	90	90
1200	N/A	80	90
1350	N/A	80	90
1500	N/A	80	80
1800	N/A	N/A	80
2100	N/A	N/A	70

Shading indicates preferred spring option.

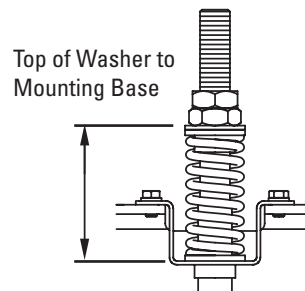

Specifications:

- Maximum Belt SpeedContact Flexco®
- Temperature Rating-35°C to 82°C
- Usable Blade Wear Length.....9 mm
- Blade Materials.....C-Tip: Impact Resistant Tungsten Carbide (works with mechanical fasteners)
V-Tip: Long Life Tungsten Carbide (for vulcanised belts only)

Product Ordering Information

Spring Covers and Tensioner Lock

Spring Covers

ORDERING NUMBER	ITEM CODE	WT. KG.
SPG-CVR-A	77387	0.14
SPG-CVR-B	77388	0.14
SPG-CVR-C	77389	0.14
SPG-CVR-D	77390	0.18
SPG-CVR-E	77391	0.18
SPG-CVR-F	77392	0.14
SPG-CVR-G	77393	0.14
SPG-CVR-H	77741	0.14

Includes 1 spring cover

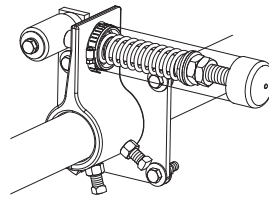
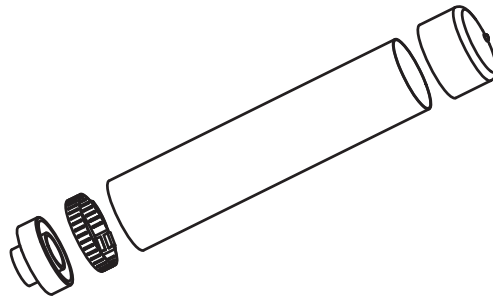

Spring cover on Primary Cleaner tensioner

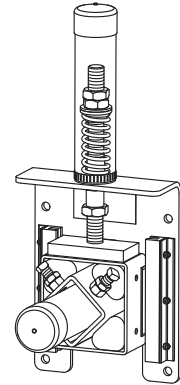

Spring cover on Secondary cleaner tensioner

Tensioner Lock

Designed to prevent tampering or unauthorized retensioning of the cleaner.

ORDERING NUMBER	ITEM CODE	WT. KG.
TEN-LOCK-KIT	77443	0.18

*For MSP, MMP, MHP, MHCP, H-Type® Primary Cleaner and MSS, MHS, MDWS Secondary Cleaners

Includes 1 tensioner lock

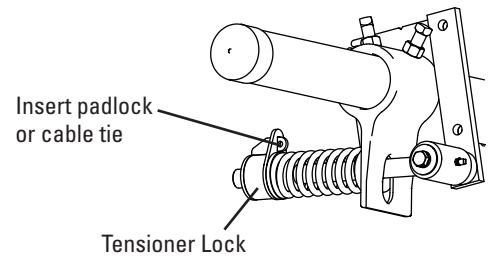
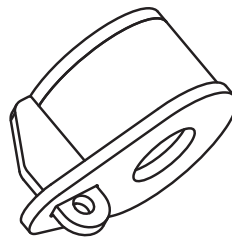

Tensioner Lock

(Primary Cleaner tensioner shown)

Patent pending

Stock items (non-shaded) refer to (*) for specific lead time, if not specified, standard lead time applies.

Non-stock items (shaded) please contact Flexco for dispatch options and lead times.

Product Ordering Information

P-Type® SAC Secondary Cleaner with Service Advantage Cartridge™

P-Type® SAC Secondary with V-Tips*

BELT WIDTH mm	ORDERING NUMBER	ITEM CODE	WT. KG.
600	PV600-SAC	78020	62.3
750	PV750-SAC	78021	68.4
900	PV900-SAC	78022	74.4
1050	PV1050-SAC	78023	80.4
1200	PV1200-SAC	78024	86.4
1350	PV1350-SAC	78025	92.5
1500	PV1500-SAC	78026	98.5
1800	PV1800-SAC	78027	110.6
1500	PV1500-2SAC	78028	137.8
1800	PV1800-2SAC	78029	150.0
2100	PV2100-2SAC	78030	162.5
2400	PV2400-2SAC	78031	174.7
3000	PV3000-2SAC	78032	201.3

*NOTE: V-Tips can be used ONLY on vulcanised belts.

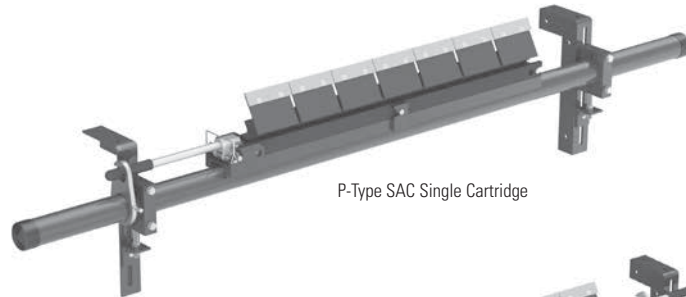

P-Type SAC Single Cartridge

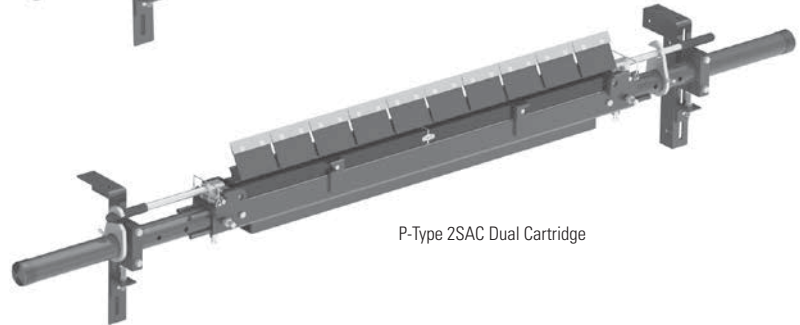

P-Type 2SAC Dual Cartridge

P-Type SAC Stainless Steel Secondary with V-Tips*

BELT WIDTH mm	ORDERING NUMBER	ITEM CODE	WT. KG.
600	PV600-SAC-S/S	78329	62.3
750	PV750-SAC-S/S	78330	68.4
900	PV900-SAC-S/S	78331	74.4
1050	PV1050-SAC-S/S	78332	80.4
1200	PV1200-SAC-S/S	78333	86.4
1350	PV1350-SAC-S/S	78334	92.5
1500	PV1500-SAC-S/S	78335	98.5
1800	PV1800-SAC-S/S	78336	110.6
1500	PV1500-2SAC-S/S	78337	137.8
1800	PV1800-2SAC-S/S	78338	150.0
1950	PV1950-2SAC-S/S	78656	156.2
2100	PV2100-2SAC-S/S	78339	162.5
2400	PV2400-2SAC-S/S	78340	174.7
3000	PV3000-2SAC-S/S	78341	201.3

*NOTE: V-Tips can be used ONLY on vulcanised belts.

Replacement Tips

ORDERING NUMBER	ITEM CODE	WT. KG.
CT6 (C-Tip)	74535	0.4
PSA150 (V-Tip)	73156	0.4

Tips Required Per Cleaner Size

BELT WIDTH mm	BLADE COVERAGE mm	V-TIPS REQUIRED
600	600	4
750	750	5
900	900	6
1050	1050	7
1200	1200	8
1350	1350	9
1500	1500	10
1800	1800	12
2100	2100	14
2400	2400	16
3000	3000	20

Product Notes:

- Patent-pending Service Advantage Cartridge™ allows for easy removal in even the dirtiest conditions.
- Pole Length: Belt width plus 1350 mm (single cartridge cleaners); Belt width plus 1500 mm (dual cartridge cleaners).
- Tips are set at a non-aggressive 70° angle to give quick relief for passing mechanical splices.
- C-Tips are for mechanically fastened or vulcanised belts. V-Tips are for vulcanised belts only.
- Tensioner mounting brackets included for fast and easy installation.
- Cartridge Removal Kit included for easy removal of the cartridge.

Stock items (non-shaded) refer to (*) for specific lead time, if not specified, standard lead time applies.

Non-stock items (shaded) please contact Flexco for dispatch options and lead times.

U.S. Patent Pending

Product Ordering Information

P-Type® SAC Secondary Cleaner with Service Advantage Cartridge™

P-Type® SAC Cartridge Kits with V-Tips*

BELT WIDTH mm	ORDERING NUMBER	ITEM CODE	WT. KG.
600	P-CARK-V24/600	78080	11.4
750	P-CARK-V30/750	78081	13.6
900	P-CARK-V36/900	78082	15.7
1050	P-CARK-V42/1050	78083	17.9
1200	P-CARK-V48/1200	78084	20.0
1350	P-CARK-V54/1350	78085	22.2
1500	P-CARK-V60/1500	78086	24.4
1800	P-CARK-V72/1800	78087	28.7
1500	P-CARK2-V60/1500	78093	39.7
1800	P-CARK2-V72/1800	78094	46.4
2100	P-CARK2-V84/2100	78095	53.2
2400	P-CARK2-V96/2400	78096	59.9
3000	P-CARK2-V120/3000	78097	73.6

*NOTE: V-Tips can be used ONLY on vulcanised belts.

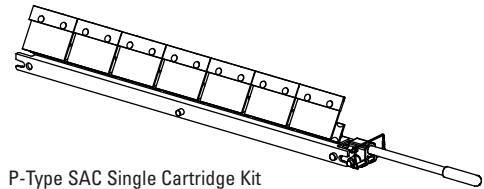

P-Type SAC Single Cartridge Kit

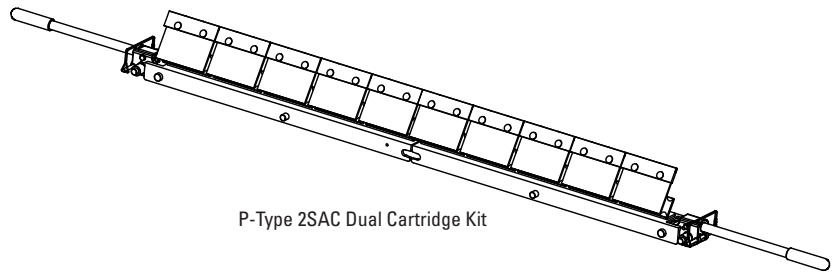

P-Type 2SAC Dual Cartridge Kit

P-Type SAC Stainless Steel Cartridge Kits with V-Tips*

BELT WIDTH mm	ORDERING NUMBER	ITEM CODE	WT. KG.
600	P-CARK-V24/600-S/S PVECKS/S	82815	11.4
750	P-CARK-V30/750-S/S PVECKS/S	82816	13.6
900	P-CARK-V36/900-S/S PVECKS/S	82817	15.7
1050	P-CARK-V42/1050-S/S PVECKS/S	82818	17.9
1200	P-CARK-V48/1200-S/S PVECKS/S	82819	20.0
1350	P-CARK-V54/1350-S/S PVECKS/S	82820	22.2
1500	P-CARK-V60/1500-S/S PVECKS/S	82821	24.4
1800	P-CARK-V72/1800-S/S PVECKS/S	82822	28.7
1500	P-CARK2-V60/1500-S/S PV2ECKSS	82823	39.7
1800	P-CARK2-V72/1800-S/S PV2ECKSS	82824	46.4
2000	P-CARK2-V78/1950-S/S PV2ECKSS	82876	49.2
2100	P-CARK2-V84/2100-S/S PV2ECKSS	82825	53.2
2400	P-CARK2-V96/2400-S/S PV2ECKSS	82826	59.9
3000	P-CARK2-V120/3000-S/S PV2ECKSS	82827	73.6

*NOTE: V-Tips can be used ONLY on vulcanised belts.

Stock items (non-shaded) refer to (*) for specific lead time, if not specified, standard lead time applies.

Non-stock items (shaded) please contact Flexco for dispatch options and lead times.

Replacement Parts List

P-Type® SAC (Mild Steel) Secondary Cleaner with Service Advantage Cartridge™

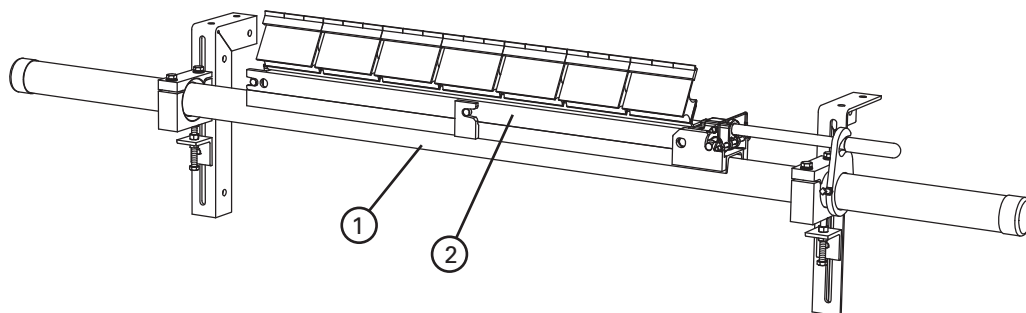

Replacement Parts

REF	DESCRIPTION	ORDERING NUMBER	ITEM CODE	WT. KG.
1	SAC Cartridge Pole 600 mm	SACPL-24/600	77887	29.7
	SAC Cartridge Pole 750 mm	SACPL-30/750	77888	32.3
	SAC Cartridge Pole 900 mm	SACPL-36/900	77889	35.0
	SAC Cartridge Pole 1050 mm	SACPL-42/1050	77890	37.6
	SAC Cartridge Pole 1200 mm	SACPL-48/1200	77891	40.3
	SAC Cartridge Pole 1350 mm	SACPL-54/1350	77892	42.9
	SAC Cartridge Pole 1500 mm	SACPL-60/1500	77893	45.6
	SAC Cartridge Pole 1800 mm	SACPL-72/1800	77894	50.9
	SAC Cartridge Center Pole 1500 mm (Dual)	SACPL2-60/1500	77895	35.1
	SAC Cartridge Center Pole 1800 mm (Dual)	SACPL2-72/1800	77896	40.6
	SAC Cartridge Center Pole 2100 mm (Dual)	SACPL2-84/2100	77897	46.2
	SAC Cartridge Center Pole 2400 mm (Dual)	SACPL2-96/2400	77898	51.8
	SAC Cartridge Center Pole 3000 mm (Dual)	SACPL2-120/3000	77899	64.5
	1a	Extender Pole (for use with Dual Cartridge Center Pole)	MHP-EP	76392
2	SAC Repl Cartridge S/S 600 mm	CART-24/600-S/S	78576	4.5
	SAC Repl Cartridge S/S 750 mm	CART-30/750-S/S	78577	5.6
	SAC Repl Cartridge S/S 900 mm	CART-36/900-S/S	78578	6.7
	SAC Repl Cartridge S/S 1050 mm	CART-42/1050-S/S	78579	7.8
	SAC Repl Cartridge S/S 1200 mm	CART-48/1200-S/S	78580	8.9
	SAC Repl Cartridge S/S 1350 mm	CART-54/1350-S/S	78581	10.0
	SAC Repl Cartridge S/S 1500 mm	CART-60/1500-S/S	78582	11.3
	SAC Repl Cartridge S/S 1800 mm	CART-72/1800-S/S	78583	13.5
	SAC Repl Cartridge S/S 1500 mm (Dual)	CART2-60/1500-S/S	78584	11.2
	SAC Repl Cartridge S/S 1800 mm (Dual)	CART2-72/1800-S/S	78585	13.4
	SAC Repl Cartridge S/S 1950 mm (Dual)	CART2-78/1950-S/S	78635	14.5
	SAC Repl Cartridge S/S 2100 mm (Dual)	CART2-84/2100-S/S	78586	15.6
	SAC Repl Cartridge S/S 2400 mm (Dual)	CART2-96/2400-S/S	78587	17.8
	SAC Repl Cartridge S/S 3000 mm (Dual)	CART2-120/3000-S/S	78588	22.6

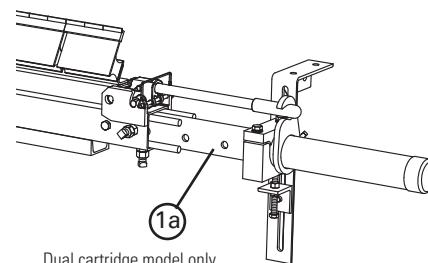

Stock items (non-shaded) refer to (*) for specific lead time, if not specified, standard lead time applies.

Non-stock items (shaded) please contact Flexco for dispatch options and lead times.

Replacement Parts List

P-Type® SAC (Mild Steel) Secondary Cleaner with Service Advantage Cartridge™

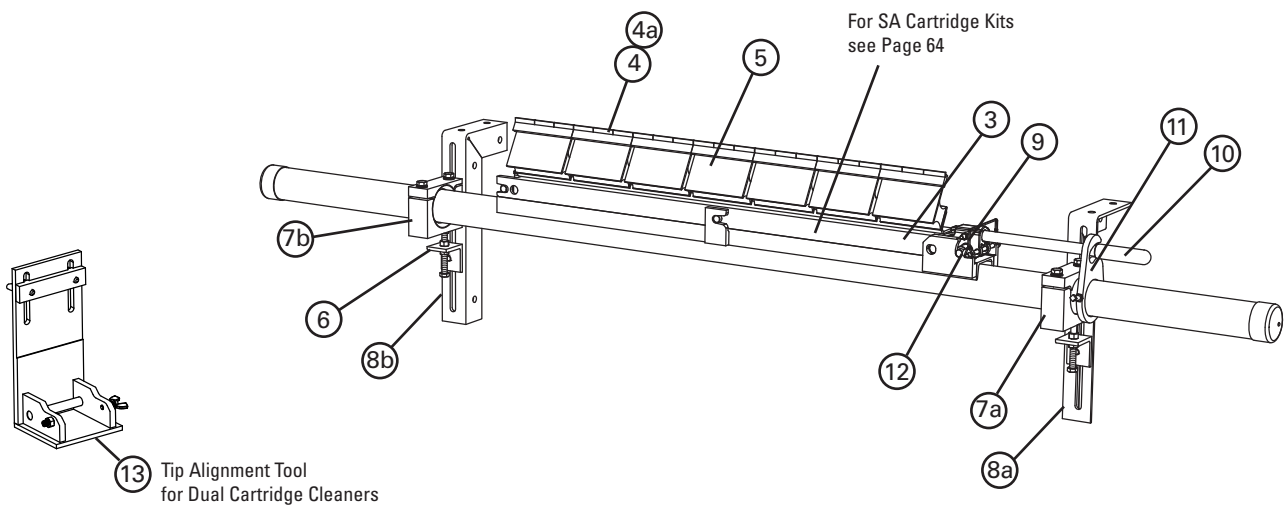

Replacement Parts (Continued)

REF	DESCRIPTION	ORDERING NUMBER	ITEM CODE	WT. KG.
3	SAC Cartridge P-Type® Adapter Plate 600 mm	PCAP-24/600	77913	2.1
	SAC Cartridge P-Type Adapter Plate 750 mm §	PCAP-30/750	77914	2.8
	SAC Cartridge P-Type Adapter Plate 900 mm §	PCAP-36/900	77915	3.3
	SAC Cartridge P-Type Adapter Plate 1050 mm §	PCAP-42/1050	77916	3.9
	SAC Cartridge P-Type Adapter Plate 1200 mm §	PCAP-48/1200	77917	4.4
	SAC Cartridge P-Type Adapter Plate 1350 mm	PCAP-54/1350	77918	5.0
	SAC Cartridge P-Type Adapter Plate 1500 mm §	PCAP-60/1500	77919	5.6
	SAC Cartridge P-Type Adapter Plate 1800 mm	PCAP-72/1800	77920	6.7
4	C-Tip*	CT6	74535	0.4
4a	P V-Tip* (for vulcanised belts only)	PSA150	73156	0.4
5	Cushion*	PHA	73626	1.6
6	P/R Adjusting Bracket	PAB	75513	0.4
7a	Cradle Clamp Block RH	SMR-CCB-R73	A2843	1.2
7b	Cradle Clamp Block LH	SMR-CCB-L73	A2842	1.2
8a	Mounting Bracket Kit, RH	PMBR	75519	3.8
8b	Mounting Bracket Kit, LH	PMBL	75516	3.8
9	SAC Removal Knuckle	SACRKN	77882	1.5
10	SAC Removal Handle	SACRH	77883	1.4
11	SAC Handle Lock Plate	SACRHL	77884	0.8
12	Knuckle Retainer Pin	SACKRP	77885	0.1
-	SAC Removal Kit (includes 1 ea. items 9,10,11,12)	SACRKT	77886	4.1
13	SAC Cartridge Tip Alignment Tool (Dual)	SAC2-TIP-TL	77866	1.1
-	Cradle Clamp Heavy-Duty Mounting Kit (incl. 2 ea. item 6; incl. 1 ea. items 7a, 7b, 8a, 8b)	CRHMK	62400	10.8

§ If using a dual cartridge, please take the cleaner size and divide by two. That dimension is the size of the brackets needed for conversion to a P-Type cleaner.

Stock items (non-shaded) refer to (*) for specific lead time, if not specified, standard lead time applies.
Non-stock items (shaded) please contact Flexco for dispatch options and lead times.

Replacement Parts List

P-Type[®] SAC (Stainless Steel) Secondary Cleaner with Service Advantage Cartridge[™]

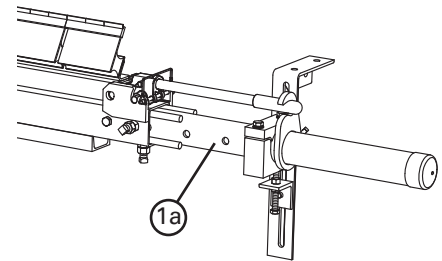
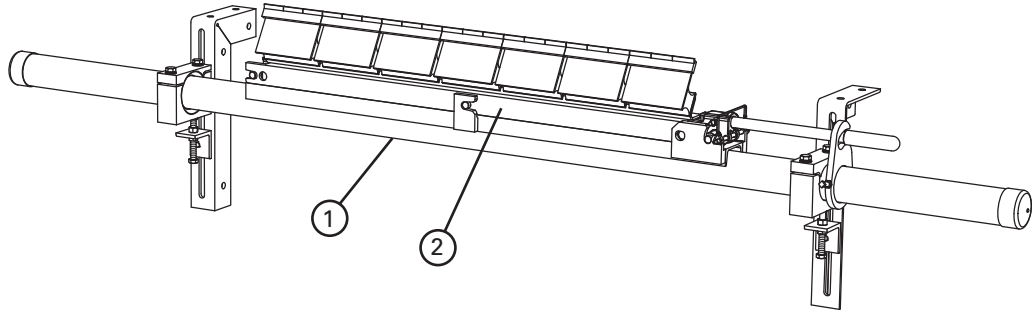

Dual cartridge model only

Replacement Parts

REF	DESCRIPTION	ORDERING NUMBER	ITEM CODE	WT. KG.
1	SAC S/S Cartridge Pole 600 mm	SACPL-24/600-S/S	78371	29.7
	SAC S/S Cartridge Pole 750 mm	SACPL-30/750-S/S	78372	32.3
	SAC S/S Cartridge Pole 900 mm	SACPL-36/900-S/S	78373	35.0
	SAC S/S Cartridge Pole 1050 mm	SACPL-42/1050-S/S	78374	37.6
	SAC S/S Cartridge Pole 1200 mm	SACPL-48/1200-S/S	78375	40.3
	SAC S/S Cartridge Pole 1350 mm	SACPL-54/1350-S/S	78376	42.9
	SAC S/S Cartridge Pole 1500 mm	SACPL-60/1500-S/S	78377	45.6
	SAC S/S Cartridge Pole 1800 mm	SACPL-72/1800-S/S	78378	50.9
	SAC S/S Cartridge Center Pole 1500 mm (Dual)	SACPL2-60/1500-S/S	78379	35.1
	SAC S/S Cartridge Center Pole 1800 mm (Dual)	SACPL2-72/1800-S/S	78380	40.6
	SAC S/S Cartridge Center Pole 1950 mm (Dual)	SACPL2-78/1950-S/S	78642	43.9
	SAC S/S Cartridge Center Pole 2100 mm (Dual)	SACPL2-84/2100-S/S	78381	46.2
	SAC S/S Cartridge Center Pole 2400 mm (Dual)	SACPL2-96/2400-S/S	78382	51.8
	SAC S/S Cartridge Center Pole 3000 mm (Dual)	SACPL2-120/3000-S/S	78383	64.5
	1a	S/S Extender Pole (for use with S/S Dual Cartridge Center Pole)	MHP-EP-S/S	77599
2	SAC Repl Cartridge S/S 600 mm	CART-24/600-S/S	78576	4.5
	SAC Repl Cartridge S/S 750 mm	CART-30/750-S/S	78577	5.6
	SAC Repl Cartridge S/S 900 mm	CART-36/900-S/S	78578	6.7
	SAC Repl Cartridge S/S 1050 mm	CART-42/1050-S/S	78579	7.8
	SAC Repl Cartridge S/S 1200 mm	CART-48/1200-S/S	78580	8.9
	SAC Repl Cartridge S/S 1350 mm	CART-54/1350-S/S	78581	10.0
	SAC Repl Cartridge S/S 1500 mm	CART-60/1500-S/S	78582	11.3
	SAC Repl Cartridge S/S 1800 mm	CART-72/1800-S/S	78583	13.5
	SAC Repl Cartridge S/S 1500 mm (Dual)	CART2-60/1500-S/S	78584	11.2
	SAC Repl Cartridge S/S 1800 mm (Dual)	CART2-72/1800-S/S	78585	13.4
	SAC Repl Cartridge S/S 1950 mm (Dual)	CART2-78/1950-S/S	78635	14.5
	SAC Repl Cartridge S/S 2100 mm (Dual)	CART2-84/2100-S/S	78586	15.6
	SAC Repl Cartridge S/S 2400 mm (Dual)	CART2-96/2400-S/S	78587	17.8
	SAC Repl Cartridge S/S 3000 mm (Dual)	CART2-120/3000-S/S	78588	22.6

Stock items (non-shaded) refer to (*) for specific lead time, if not specified, standard lead time applies.

Non-stock items (shaded) please contact Flexco for dispatch options and lead times.

Replacement Parts List

P-Type® SAC (Stainless Steel) Secondary Cleaner with Service Advantage Cartridge™

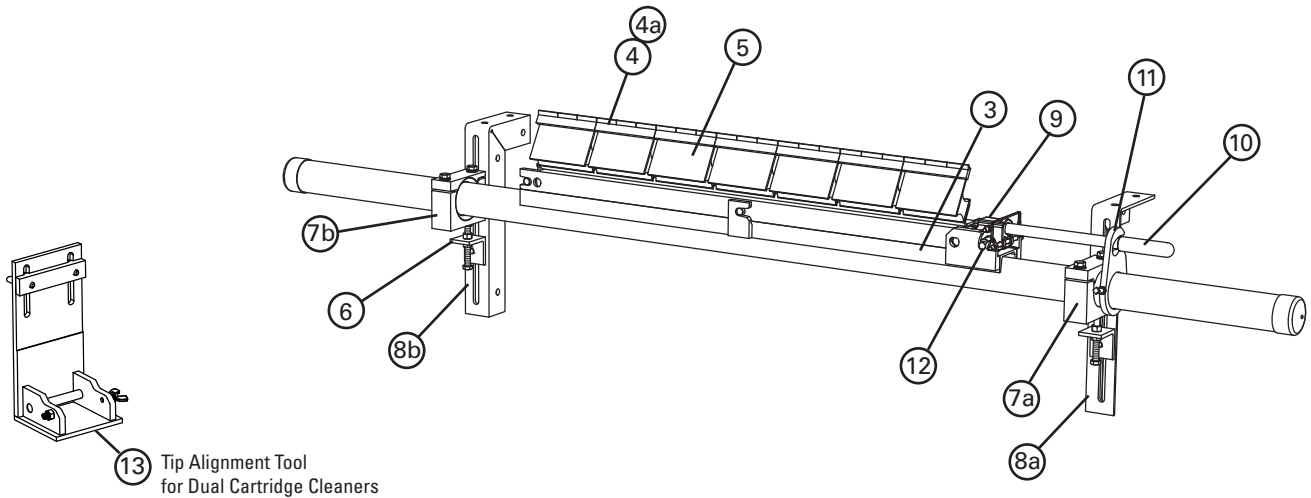

Replacement Parts (Continued)

REF	DESCRIPTION	ORDERING NUMBER	ITEM CODE	WT. KG.
3	SAC Cartridge P-Type® S/S Adapter Plate 600 mm	PCAP-24/600-S/S	78355	2.1
	SAC Cartridge P-Type S/S Adapter Plate 750 mm §	PCAP-30/750-S/S	78356	2.8
	SAC Cartridge P-Type S/S Adapter Plate 900 mm §	PCAP-36/900-S/S	78357	3.3
	SAC Cartridge P-Type S/S Adapter Plate 1050 mm §	PCAP-42/1050-S/S	78358	3.9
	SAC Cartridge P-Type S/S Adapter Plate 1200 mm §	PCAP-48/1200-S/S	78359	4.4
	SAC Cartridge P-Type S/S Adapter Plate 1350 mm	PCAP-54/1350-S/S	78360	5.0
	SAC Cartridge P-Type S/S Adapter Plate 1500 mm §	PCAP-60/1500-S/S	78361	5.6
	SAC Cartridge P-Type S/S Adapter Plate 1800 mm	PCAP-72/1800-S/S	78362	6.7
4	C-Tip	CT6	74535	0.4
4a	S/S P V-Tip	PVT6-S/S	75420	0.4
5	S/S P Cushion*	PHSC-S/S	73433	1.6
6	P/R Adjusting Bracket S/S	PAB-S/S	75515	0.4
7a	Cradle Clamp Block RH S/S	CRDLBLK-RH-S/S	A2825	1.2
7b	Cradle Clamp Block LH S/S	CRDLBLK-LH-S/S	A2826	1.2
8a	Mounting Bracket Kit RH S/S	PMBR-S/S	75521	3.8
8b	Mounting Bracket Kit LH S/S	PMBL-S/S	75518	3.8
9	SAC Removal Knuckle	SACRKN	77882	1.5
10	SAC Removal Handle S/S	SACRH-S/S	78397	1.4
11	SAC Handle Lock Plate S/S	SACRHL-S/S	78398	0.8
12	Knuckle Retainer Pin S/S	SACKRP-S/S	78399	0.1
-	SAC Removal Kit S/S (includes 1 ea. items 9,10,11,12)	SACRKT-S/S	78401	4.1
13	SAC Cartridge Tip Alignment Tool (Dual)	SAC2-TIP-TL	77866	1.1
-	Cradle Clamp Stainless Steel Heavy-Duty Mounting Kit (incl. 2 ea. item 6; incl. 1 ea. items 7a, 7b, 8a, 8b)	CRHMK-S/S	62095	10.8

§ If using a dual cartridge, please take the cleaner size and divide by two. That dimension is the size of the brackets needed for conversion to a P-Type cleaner.

Stock items (non-shaded) refer to (*) for specific lead time, if not specified, standard lead time applies.

Non-stock items (shaded) please contact Flexco for dispatch options and lead times.

Specifications & Guidelines

P-Type® SAC
Secondary Cleaner
with Service Advantage Cartridge™

Pole Length Specifications*

VERSION	CLEANER SIZE mm	BLADE WIDTH mm	POLE LENGTH mm	MAXIMUM CONVEYOR SPAN mm
Single	600	600	1950	1650
	750	750	2100	1800
	900	900	2250	1950
	1050	1050	2400	2100
	1200	1200	2550	2250
	1350	1350	2700	2400
	1500	1500	2850	2550
Dual	1500	1500	3000	2700
	1800	1800	3300	3000
	2100	2100	3600	3300
	2400	2400	3900	3600
	3000	3000	4500	4200

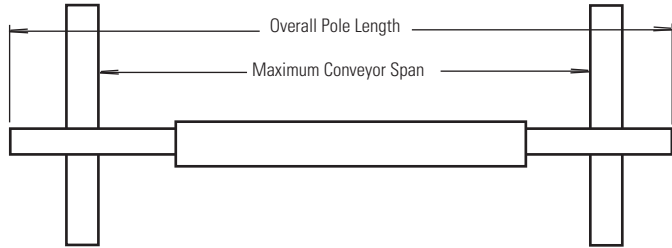

*For special extra long pole length requirements a Pole Extender Kit (#76024) is available that provides 750 mm of extended pole length.
 Pole Diameter - 73 mm

Clearance Guidelines for Installation

VERSION	HORIZONTAL CLEARANCE REQUIRED mm	VERTICAL CLEARANCE REQUIRED mm
Single	114	267
Dual	114	311

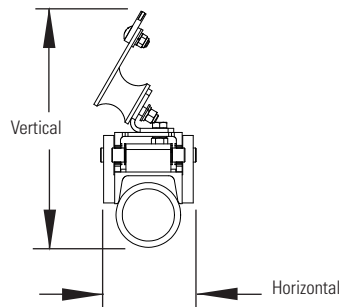

Specifications:

- Maximum Belt Speed5M/sec
- Temperature Rating-35°C to 82°C
- Usable Blade Wear Length.....9 mm
- Blade MaterialsC-Tip: Impact Resistant Tungsten Carbide (works with mechanical fasteners)
 V-Tip: Long Life Tungsten Carbide (for vulcanised belts only)
- Available for Belt Widths600 to 3000 mm. Other sizes available upon request.

U.S. Patent Pending

Product Ordering Information

R-Type® SAC Secondary Cleaner with Service Advantage Cartridge™

R-Type® SAC Secondary with V-Tips*

BELT WIDTH mm	ORDERING NUMBER	ITEM CODE	WT. KG.
600	RV600-SAC	78033	58.3
750	RV750-SAC	78034	63.3
900	RV900-SAC	78035	68.3
1050	RV1050-SAC	78036	73.3
1200	RV1200-SAC	78037	78.3
1350	RV1350-SAC	78038	83.3
1500	RV1500-SAC	78039	88.4
1800	RV1800-SAC	78040	98.3
1500	RV1500-2SAC	78041	107.5
1800	RV1800-2SAC	78042	117.7
2100	RV2100-2SAC	78043	127.8
2400	RV2400-2SAC	78044	138.0
3000	RV3000-2SAC	78045	160.6

*NOTE: V-Tips can be used ONLY on vulcanised belts.

R-Type SAC Stainless Steel Secondary with V-Tips*

BELT WIDTH mm	ORDERING NUMBER	ITEM CODE	WT. KG.
600	RV600-SAC-S/S	78342	58.3
750	RV750-SAC-S/S	78343	63.3
900	RV900-SAC-S/S	78344	68.3
1050	RV1050-SAC-S/S	78345	73.3
1200	RV1200-SAC-S/S	78346	78.3
1350	RV1350-SAC-S/S	78347	83.3
1500	RV1500-SAC-S/S	78348	88.4
1800	RV1800-SAC-S/S	78349	98.3
1500	RV1500-2SAC-S/S	78350	107.5
1800	RV1800-2SAC-S/S	78351	117.7
1950	RV1950-2SAC-S/S	78663	122.7
2100	RV2100-2SAC-S/S	78352	127.8
2400	RV2400-2SAC-S/S	78353	138.0
3000	RV3000-2SAC-S/S	78354	160.6

*NOTE: V-Tips can be used ONLY on vulcanised belts.

Product Notes:

- Patent-pending Service Advantage Cartridge™ allows for easy removal in even the dirtiest conditions.
- Pole Length: Belt width plus 1350mm (single cartridge cleaners); Belt width plus 1500mm (dual cartridge cleaners).
- Two-way cushions allow cleaning in both directions.
- C-Tips are for mechanically fastened or vulcanised belts. V-Tips are for vulcanised belts only.
- Tensioner mounting brackets included for fast and easy installation.
- Cartridge Removal Kit included for easy removal of the cartridge.

U.S. Patent Pending

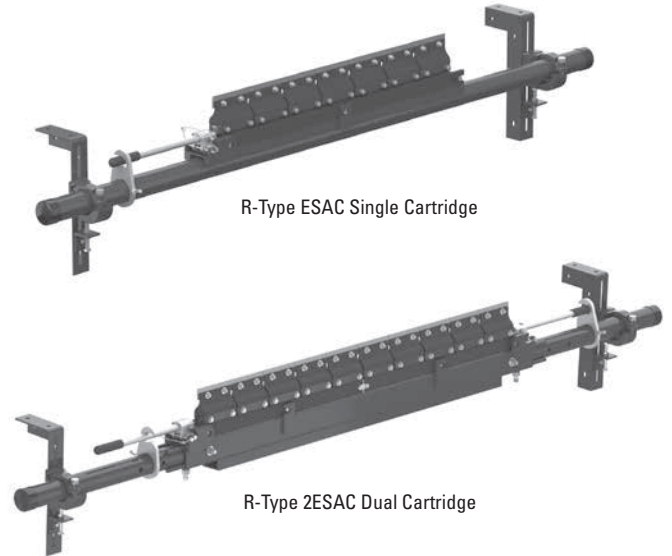

R-Type ESAC Single Cartridge

R-Type 2ESAC Dual Cartridge

Replacement Tips

ORDERING NUMBER	ITEM CODE	WT. KG.
CT6 (C-Tip)	74535	0.4
RSA150 (V-Tip)	73628	0.4

Tips Required Per Cleaner Size

BELT WIDTH mm	BLADE COVERAGE mm	V-TIPS REQUIRED
600	600	4
750	750	5
900	900	6
1050	1050	7
1200	1200	8
1350	1350	9
1500	1500	10
1800	1800	12
2100	2100	14
2400	2400	16
3000	3000	20

Stock items (non-shaded) refer to (*) for specific lead time, if not specified, standard lead time applies.

Non-stock items (shaded) please contact Flexco for dispatch options and lead times.

Product Ordering Information

R-Type® SAC
Secondary Cleaner
with Service Advantage Cartridge™

R-Type® SAC Cartridge Kits with V-Tips*

BELT WIDTH mm	ORDERING NUMBER	ITEM CODE	WT. KG.
600	R-CARK-V24/600	78106	12.3
750	R-CARK-V30/750	78107	14.7
900	R-CARK-V36/900	78108	16.5
1050	R-CARK-V42/1050	78109	19.3
1200	R-CARK-V48/1200	78110	21.6
1350	R-CARK-V54/1350	78111	24.0
1500	R-CARK-V60/1500	78112	26.4
1800	R-CARK-V72/1800	78113	31.1
1500	R-CARK2-V60/1500	78119	31.6
1800	R-CARK2-V72/1800	78120	33.9
2100	R-CARK2-V84/2100	78121	38.6
2400	R-CARK2-V96/2400	78122	43.3
3000	R-CARK2-V120/3000	78123	52.8

*NOTE: V-Tips can be used ONLY on vulcanised belts.

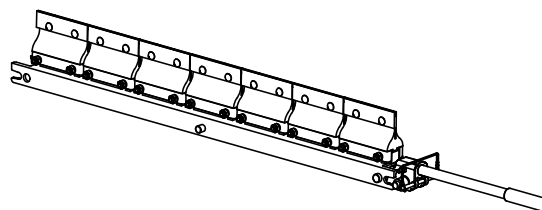

R-Type SAC Single Cartridge Kit

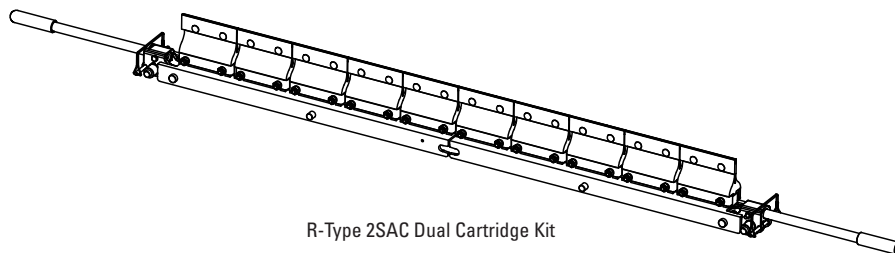

R-Type 2SAC Dual Cartridge Kit

R-Type SAC Stainless Steel Cartridge Kits with V-Tips*

BELT WIDTH mm	ORDERING NUMBER	ITEM CODE	WT. KG.
600	R-CARK-V24/600-S/S RVECKS/S	82828	12.3
750	R-CARK-V30/750-S/S RVECKS/S	82829	14.7
900	R-CARK-V36/900-S/S RVECKS/S	82830	16.5
1050	R-CARK-V42/1050-S/S RVECKS/S	82831	19.3
1200	R-CARK-V48/1200-S/S RVECKS/S	82832	21.6
1350	R-CARK-V54/1350-S/S RVECKS/S	82833	24.0
1500	R-CARK-V60/1500-S/S RVECKS/S	82834	26.4
1800	R-CARK-V72/1800-S/S RVECKS/S	82835	31.1
1500	R-CARK2-V60/1500-S/S RV2ECKSS	82836	31.6
1800	R-CARK2-V72/1800-S/S RV2ECKSS	82837	33.9
2100	R-CARK2-V84/2100-S/S RV2ECKSS	82838	38.6
2400	R-CARK2-V96/2400-S/S RV2ECKSS	82839	43.3
3000	R-CARK2-V120/3000-S/S RV2ECKSS	82840	52.8

*NOTE: V-Tips can be used ONLY on vulcanised belts.

Stock items (non-shaded) refer to (*) for specific lead time, if not specified, standard lead time applies.

Non-stock items (shaded) please contact Flexco for dispatch options and lead times.

Replacement Parts List

R-Type® SAC (Mild Steel) Secondary Cleaner with Service Advantage Cartridge™

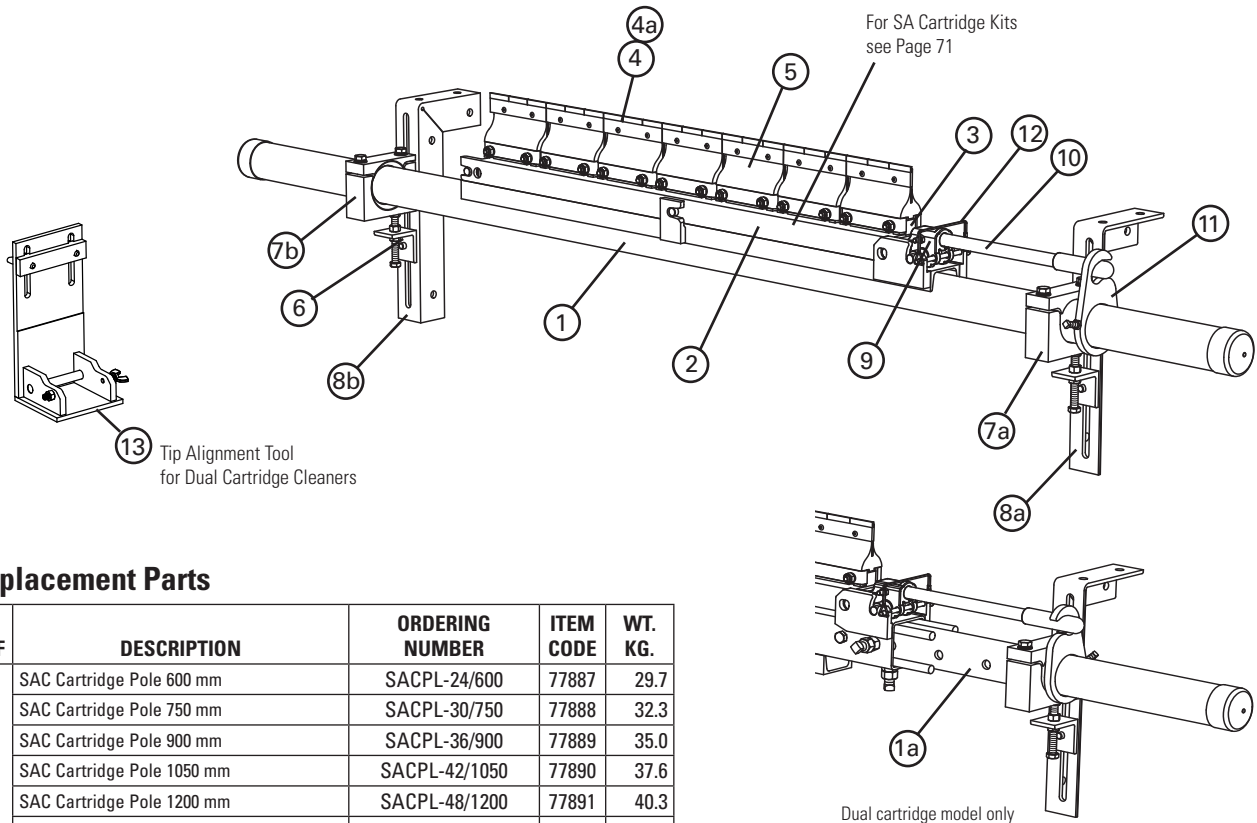

Replacement Parts

REF	DESCRIPTION	ORDERING NUMBER	ITEM CODE	WT. KG.
1	SAC Cartridge Pole 600 mm	SACPL-24/600	77887	29.7
	SAC Cartridge Pole 750 mm	SACPL-30/750	77888	32.3
	SAC Cartridge Pole 900 mm	SACPL-36/900	77889	35.0
	SAC Cartridge Pole 1050 mm	SACPL-42/1050	77890	37.6
	SAC Cartridge Pole 1200 mm	SACPL-48/1200	77891	40.3
	SAC Cartridge Pole 1350 mm	SACPL-54/1350	77892	42.9
	SAC Cartridge Pole 1500 mm	SACPL-60/1500	77893	45.6
	SAC Cartridge Pole 1800 mm	SACPL-72/1800	77894	50.9
	SAC Cartridge Center Pole 1500 mm (Dual)	SACPL2-60/1500	77895	35.1
	SAC Cartridge Center Pole 1800 mm (Dual)	SACPL2-72/1800	77896	40.6
	SAC Cartridge Center Pole 2100 mm (Dual)	SACPL2-84/2100	77897	46.2
	SAC Cartridge Center Pole 2400 mm (Dual)	SACPL2-96/2400	77898	51.8
	SAC Cartridge Center Pole 3000 mm (Dual)	SACPL2-120/3000	77899	64.5
1a	Extender Pole (for use with Dual Cartridge Center Pole)	MHP-EP	76392	24.5
2	SAC Repl Cartridge S/S 600 mm	CART-24/600-S/S	78576	4.5
	SAC Repl Cartridge S/S 750 mm	CART-30/750-S/S	78577	5.6
	SAC Repl Cartridge S/S 900 mm	CART-36/900-S/S	78578	6.7
	SAC Repl Cartridge S/S 1050 mm	CART-42/1050-S/S	78579	7.8
	SAC Repl Cartridge S/S 1200 mm	CART-48/1200-S/S	78580	8.9
	SAC Repl Cartridge S/S 1350 mm	CART-54/1350-S/S	78581	10.0
	SAC Repl Cartridge S/S 1500 mm	CART-60/1500-S/S	78582	11.3
	SAC Repl Cartridge S/S 1800 mm	CART-72/1800-S/S	78583	13.5
	SAC Repl Cartridge S/S 1500 mm (Dual)	CART2-60/1500-S/S	78584	11.2
	SAC Repl Cartridge S/S 1800 mm (Dual)	CART2-72/1800-S/S	78585	13.4
	SAC Repl Cartridge S/S 1950 mm (Dual)	CART2-78/1950-S/S	78635	14.5
	SAC Repl Cartridge S/S 2100 mm (Dual)	CART2-84/2100-S/S	78586	15.6
	SAC Repl Cartridge S/S 2400 mm (Dual)	CART2-96/2400-S/S	78587	17.8
	SAC Repl Cartridge S/S 3000 mm (Dual)	CART2-120/3000-S/S	78588	22.6

Stock items (non-shaded) refer to (*) for specific lead time, if not specified, standard lead time applies.

Non-stock items (shaded) please contact Flexco for dispatch options and lead times.

Replacement Parts List

R-Type® SAC (Mild Steel) Secondary Cleaner with Service Advantage Cartridge™

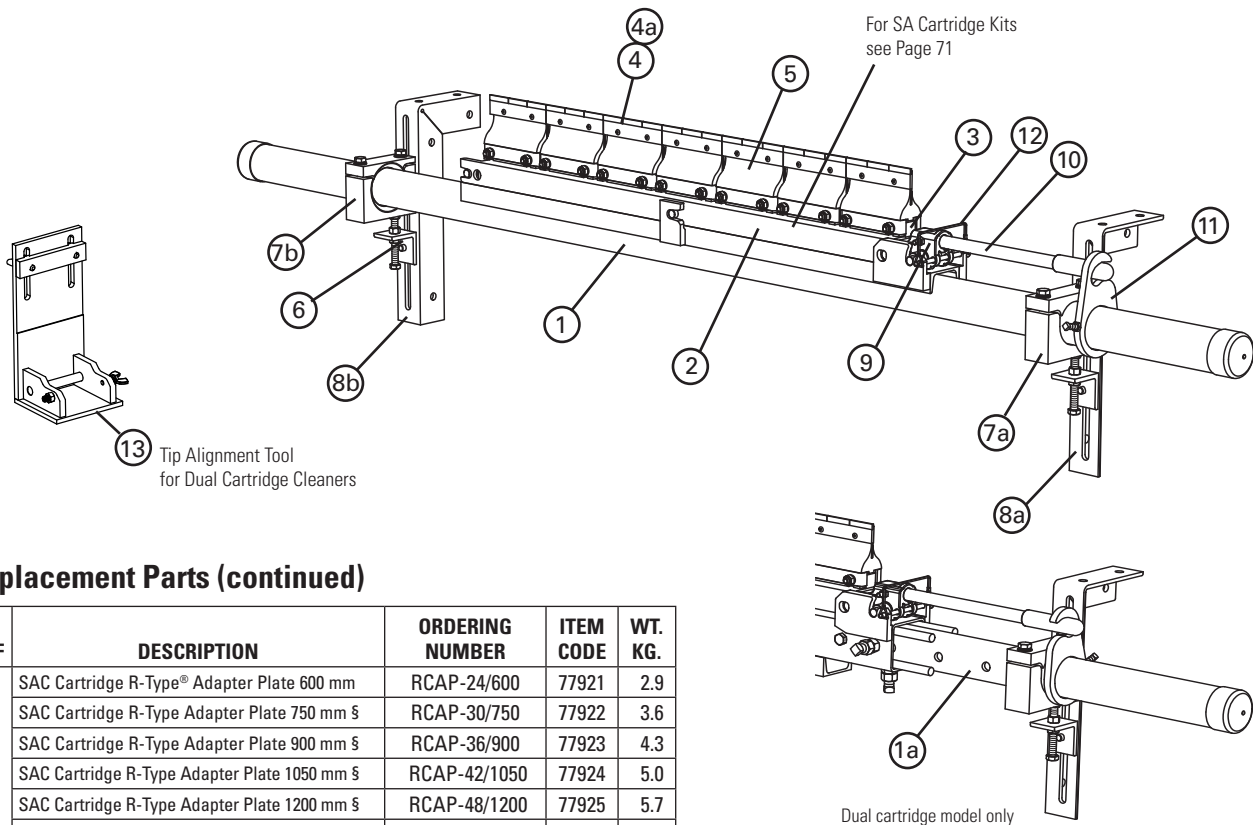

Replacement Parts (continued)

REF	DESCRIPTION	ORDERING NUMBER	ITEM CODE	WT. KG.
3	SAC Cartridge R-Type® Adapter Plate 600 mm	RCAP-24/600	77921	2.9
	SAC Cartridge R-Type Adapter Plate 750 mm §	RCAP-30/750	77922	3.6
	SAC Cartridge R-Type Adapter Plate 900 mm §	RCAP-36/900	77923	4.3
	SAC Cartridge R-Type Adapter Plate 1050 mm §	RCAP-42/1050	77924	5.0
	SAC Cartridge R-Type Adapter Plate 1200 mm §	RCAP-48/1200	77925	5.7
	SAC Cartridge R-Type Adapter Plate 1350 mm	RCAP-54/1350	77926	6.4
	SAC Cartridge R-Type Adapter Plate 1500 mm §	RCAP-60/1500	77927	7.2
	SAC Cartridge R-Type Adapter Plate 1800 mm	RCAP-72/1800	77928	8.6
4	C-Tip*	CT6	74535	0.4
4a	R V-Tip* (for vulcanised belts only)	RSA150	73628	0.4
5	Cushion*	RSA	76249	0.4
6	P/R Adjusting Bracket	PAB	75513	0.4
7a	Cradle Clamp Block RH	SMR-CCB-R73	A2843	1.2
7b	Cradle Clamp Block LH	SMR-CCB-L73	A2842	1.2
8a	Mounting Bracket Kit, RH	PMBR	75519	3.8
8b	Mounting Bracket Kit, LH	PMBL	75516	3.8
9	SAC Removal Knuckle	SACRKN	77882	1.5
10	SAC Removal Handle	SACRH	77883	1.4
11	SAC Handle Lock Plate	SACRHL	77884	0.8
12	Knuckle Retainer Pin	SACKRP	77885	0.1
-	SAC Removal Kit (includes 1 ea. items 9,10,11,12)	SACRKT	77886	4.1
13	SAC Cartridge Tip Alignment Tool (Dual)	SAC2-TIP-TL	77866	1.1
-	Cradle Clamp Heavy-Duty Mounting Kit (inc. 2 ea. items 6, 8; 1 ea. items 7a, 7b)	CRHMK	62400	10.8

§ If using a dual cartridge, please take the cleaner size and divide by two. That dimension is the size of the brackets needed for conversion to an R-Type cleaner.

Stock items (non-shaded) refer to (*) for specific lead time, if not specified, standard lead time applies.
Non-stock items (shaded) please contact Flexco for dispatch options and lead times.

Replacement Parts List

R-Type® SAC (Stainless Steel) Secondary Cleaner with Service Advantage Cartridge™

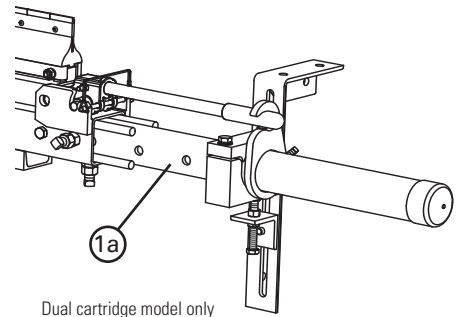
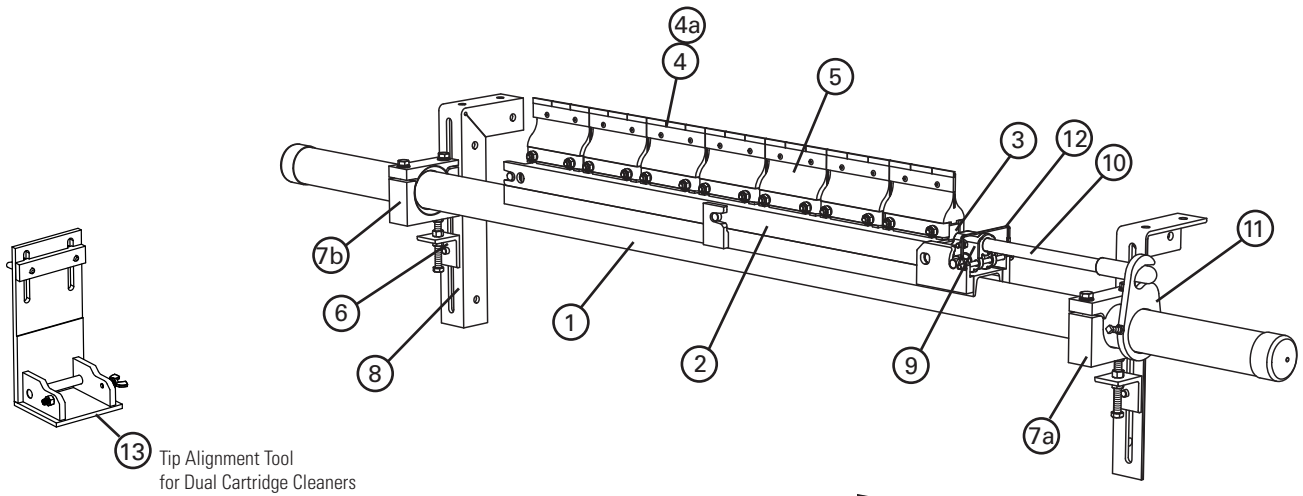

Replacement Parts

REF	DESCRIPTION	ORDERING NUMBER	ITEM CODE	WT. KG.
1	SAC S/S Cartridge Pole 600 mm	SACPL-24/600-S/S	78371	29.7
	SAC S/S Cartridge Pole 750 mm	SACPL-30/750-S/S	78372	32.3
	SAC S/S Cartridge Pole 900 mm	SACPL-36/900-S/S	78373	35.0
	SAC S/S Cartridge Pole 1050 mm	SACPL-42/1050-S/S	78374	37.6
	SAC S/S Cartridge Pole 1200 mm	SACPL-48/1200-S/S	78375	40.3
	SAC S/S Cartridge Pole 1350 mm	SACPL-54/1350-S/S	78376	42.9
	SAC S/S Cartridge Pole 1500 mm	SACPL-60/1500-S/S	78377	45.6
	SAC S/S Cartridge Pole 1800 mm	SACPL-72/1800-S/S	78378	50.9
	SAC S/S Cartridge Center Pole 1500 mm (Dual)	SACPL2-60/1500-S/S	78379	35.1
	SAC S/S Cartridge Center Pole 1800 mm (Dual)	SACPL2-72/1800-S/S	78380	40.6
	SAC S/S Cartridge Center Pole 1950 mm (Dual)	SACPL2-78/1950-S/S	78642	43.9
	SAC S/S Cartridge Center Pole 2100 mm (Dual)	SACPL2-84/2100-S/S	78381	46.2
	SAC S/S Cartridge Center Pole 2400 mm (Dual)	SACPL2-96/2400-S/S	78382	51.8
	SAC S/S Cartridge Center Pole 3000 mm (Dual)	SACPL2-120/3000-S/S	78383	64.5
1a	S/S Extender Pole (for use with S/S Dual Cartridge Center Pole)	MHP-EP-S/S	77599	24.5
2	SAC Repl Cartridge S/S 600 mm	CART-24/600-S/S	78576	4.5
	SAC Repl Cartridge S/S 750 mm	CART-30/750-S/S	78577	5.6
	SAC Repl Cartridge S/S 900 mm	CART-36/900-S/S	78578	6.7
	SAC Repl Cartridge S/S 1050 mm	CART-42/1050-S/S	78579	7.8
	SAC Repl Cartridge S/S 1200 mm	CART-48/1200-S/S	78580	8.9
	SAC Repl Cartridge S/S 1350 mm	CART-54/1350-S/S	78581	10.0
	SAC Repl Cartridge S/S 1500 mm	CART-60/1500-S/S	78582	11.3
	SAC Repl Cartridge S/S 1800 mm	CART-72/1800-S/S	78583	13.5
	SAC Repl Cartridge S/S 1500 mm (Dual)	CART2-60/1500-S/S	78584	11.2
	SAC Repl Cartridge S/S 1800 mm (Dual)	CART2-72/1800-S/S	78585	13.4
	SAC Repl Cartridge S/S 1950 mm (Dual)	CART2-78/1950-S/S	78635	14.5
	SAC Repl Cartridge S/S 2100 mm (Dual)	CART2-84/2100-S/S	78586	15.6
	SAC Repl Cartridge S/S 2400 mm (Dual)	CART2-96/2400-S/S	78587	17.8
	SAC Repl Cartridge S/S 3000 mm (Dual)	CART2-120/3000-S/S	78588	22.6

Stock items (non-shaded) refer to (*) for specific lead time, if not specified, standard lead time applies.

Non-stock items (shaded) please contact Flexco for dispatch options and lead times.

Replacement Parts List

R-Type® SAC (Stainless Steel) Secondary Cleaner with Service Advantage Cartridge™

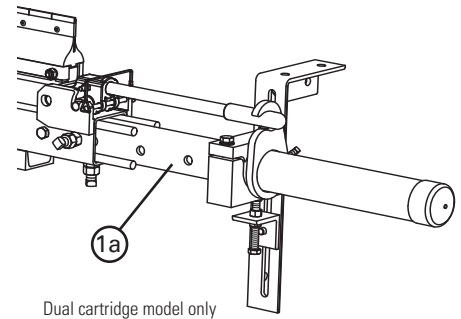
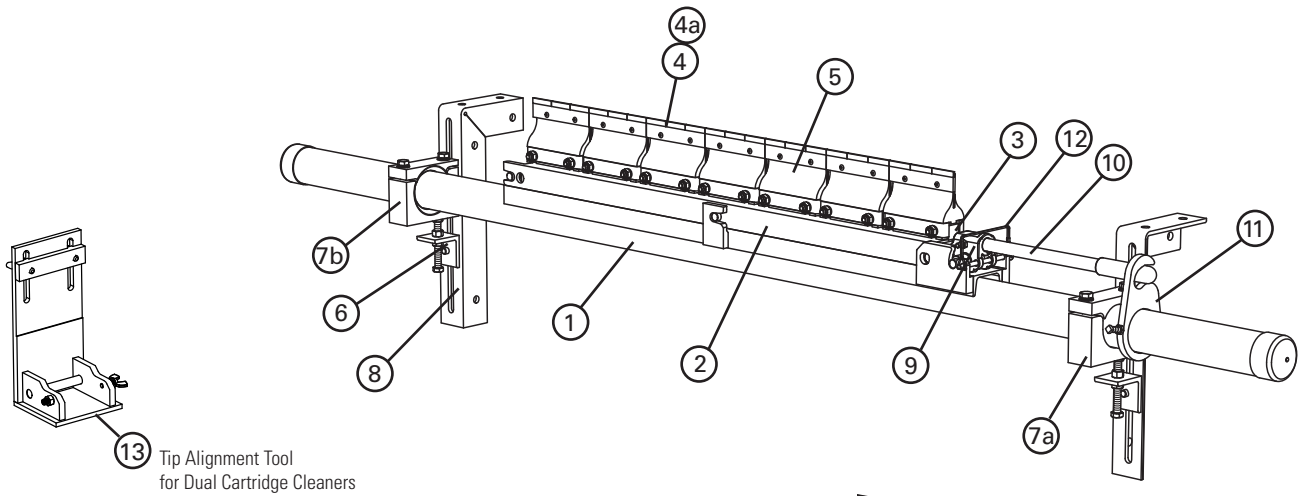

Replacement Parts (continued)

REF	DESCRIPTION	ORDERING NUMBER	ITEM CODE	WT. KG.
3	SAC Cartridge R-Type® S/S Adapter Plate 600 mm	RCAP-24/600-S/S	78363	2.9
	SAC Cartridge R-Type S/S Adapter Plate 750 mm §	RCAP-30/750-S/S	78364	3.6
	SAC Cartridge R-Type S/S Adapter Plate 900 mm §	RCAP-36/900-S/S	78365	4.3
	SAC Cartridge R-Type S/S Adapter Plate 1050 mm §	RCAP-42/1050-S/S	78366	5.0
	SAC Cartridge R-Type S/S Adapter Plate 1200 mm §	RCAP-48/1200-S/S	78367	5.7
	SAC Cartridge R-Type S/S Adapter Plate 1350 mm	RCAP-54/1350-S/S	78368	6.4
	SAC Cartridge R-Type S/S Adapter Plate 1500 mm §	RCAP-60/1500-S/S	78369	7.2
	SAC Cartridge R-Type S/S Adapter Plate 1800 mm	RCAP-72/1800-S/S	78370	8.6
4	C-Tip	CT6	74535	0.4
4a	S/S V-Tip* (for vulcanised belts only)	RVT6-S/S	76205	0.4
5	S/S R Cushion*	RC-S/S	76250	1.4
6	P/R Adjusting Bracket S/S	PAB-S/S	75515	0.4
7a	Cradle Clamp Block RH S/S	CRDLBLK-RH-S/S	A2825	1.2
7b	Cradle Clamp Block LH S/S	CRDLBLK-LH-S/S	A2826	1.2
8a	Mounting Bracket Kit RH S/S	PMBR-S/S	75521	3.8
8b	Mounting Bracket Kit LH S/S	PMBL-S/S	75518	3.8
9	SAC Removal Knuckle	SACRKN	77882	1.5
10	SAC Removal Handle S/S	SACRH-S/S	78397	1.4
11	SAC Handle Lock Plate S/S	SACRHL-S/S	78398	0.8
12	Knuckle Retainer Pin S/S	SACKRP-S/S	78399	0.1
-	SAC Removal Kit S/S (includes 1 ea. items 9,10,11,12)	SACRKT-S/S	78401	4.1
13	SAC Cartridge Tip Alignment Tool (Dual)	SAC2-TIP-TL	77866	1.1
-	Cradle Clamp Stainless Steel Heavy-Duty Mounting Kit (incl. 2 ea. item 6; incl. 1 ea. items 7a, 7b, 8a, 8b)	CRHMK-S/S	62095	10.8

§ If using a dual cartridge, please take the cleaner size and divide by two. That dimension is the size of the brackets needed for conversion to an R-Type cleaner.

Stock items (non-shaded) refer to (*) for specific lead time, if not specified, standard lead time applies.
 Non-stock items (shaded) please contact Flexco for dispatch options and lead times.

Specifications & Guidelines

R-Type® SAC
Secondary Cleaner
with Service Advantage Cartridge™

Pole Length Specifications*

VERSION	CLEANER SIZE mm	BLADE WIDTH mm	POLE LENGTH mm	MAXIMUM CONVEYOR SPAN mm
Single	600	600	1950	1650
	750	750	2100	1800
	900	900	2250	1950
	1050	1050	2400	2100
	1200	1200	2550	2250
	1350	1350	2700	2400
	1500	1500	2850	2550
	1800	1800	3150	2850
Dual	1500	1500	3000	2700
	1800	1800	3300	3000
	2100	2100	3600	3300
	2400	2400	3900	3600
	3000	3000	4500	4200

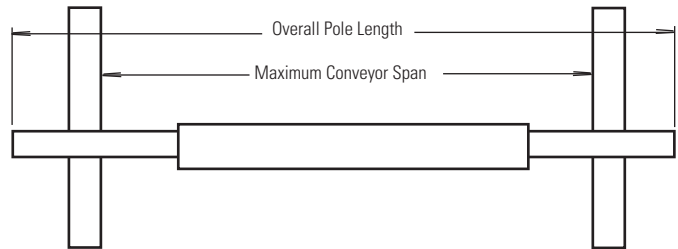

*For special extra long pole length requirements a Pole Extender Kit (#76024) is available that provides 750 mm of extended pole length. Pole Diameter - 73 mm

Clearance Guidelines for Installation

VERSION	HORIZONTAL CLEARANCE REQUIRED mm	VERTICAL CLEARANCE REQUIRED mm
Single	114	254
Dual	114	298

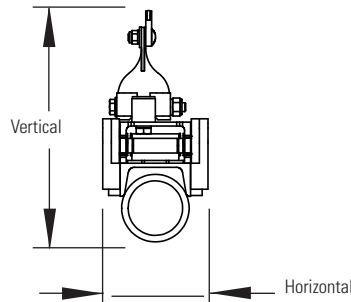

Specifications:

- Maximum Belt Speed5M/sec
- Temperature Rating-35°C to 82°C
- Usable Blade Wear Length.....9 mm
- Blade MaterialsC-Tip: Impact Resistant Tungsten Carbide (works with mechanical fasteners)
V-Tip: Long Life Tungsten Carbide (for vulcanised belts only)
- Available for Belt Widths600 to 3000 mm. Other sizes available upon request.

U.S. Patent Pending

Product Ordering Information

MHS SAC HD Secondary Cleaner with Service Advantage Cartridge™

MHS SAC Secondary with V-Tips*

BELT WIDTH mm	ORDERING NUMBER	ITEM CODE	WT. KG.
600	MHS-600V-SAC	78162	88.5
750	MHS-750V-SAC	78163	93.7
900	MHS-900V-SAC	78164	99.1
1050	MHS-1050V-SAC	78165	104.4
1200	MHS-1200V-SAC	78166	109.6
1350	MHS-1350V-SAC	78167	114.8
1500	MHS-1500V-SAC	78168	120.2
1800	MHS-1800V-SAC	78169	130.8
1500	MHS-1500V-2SAC	78170	140.2
1800	MHS-1800V-2SAC	78171	151.0
2100	MHS-2100V-2SAC	78172	161.8
2400	MHS-2400V-2SAC	78173	172.9
3000	MHS-3000V-2SAC	78174	196.2

*NOTE: V-Tips can be used ONLY on vulcanised belts.

MHS SAC Stainless Steel Secondary with V-Tips*

BELT WIDTH mm	ORDERING NUMBER	ITEM CODE	WT. KG.
600	MHS-600V-SAC-S/S	78537	88.5
750	MHS-750V-SAC-S/S	78538	93.7
900	MHS-900V-SAC-S/S	78539	99.1
1050	MHS-1050V-SAC-S/S	78540	104.4
1200	MHS-1200V-SAC-S/S	78541	109.6
1350	MHS-1350V-SAC-S/S	78542	114.8
1500	MHS-1500V-SAC-S/S	78543	120.2
1800	MHS-1800V-SAC-S/S	78544	130.8
1500	MHS-1500V-2SAC-S/S	78545	140.2
1800	MHS-1800V-2SAC-S/S	78546	151.0
1950	MHS-1950V-2SAC-S/S	78649	156.0
2100	MHS-2100V-2SAC-S/S	78547	161.8
2400	MHS-2400V-2SAC-S/S	78548	172.9
3000	MHS-3000V-2SAC-S/S	78549	196.2

*NOTE: V-Tips can be used ONLY on vulcanised belts.

Product Notes:

- Patent-pending Service Advantage Cartridge™ allows for easy removal in even the dirtiest conditions.
- Heavy-duty design to deliver maximum cleaning efficiency on the most demanding, abusive beltlines.
- Pole Length: Belt width plus 1350 mm (single cartridge cleaners); Belt width plus 1500 mm (dual cartridge cleaners).
- Patented PowerFlex™ cushion design to maintain continuous blade-to-belt contact and quick relief from passing mechanical splices.
- C-Tips are for mechanically fastened or vulcanised belts. V-Tips are for vulcanised belts only.
- Visual Blade Tension Check: Measure the tension spring and refer to Spring Length Chart on mounting base for the correct length for best cleaning performance.
- Tensioner mounting brackets included for fast and easy installation.
- Cartridge Removal Kit included for easy removal of the cartridge.

U.S. Patent Pending

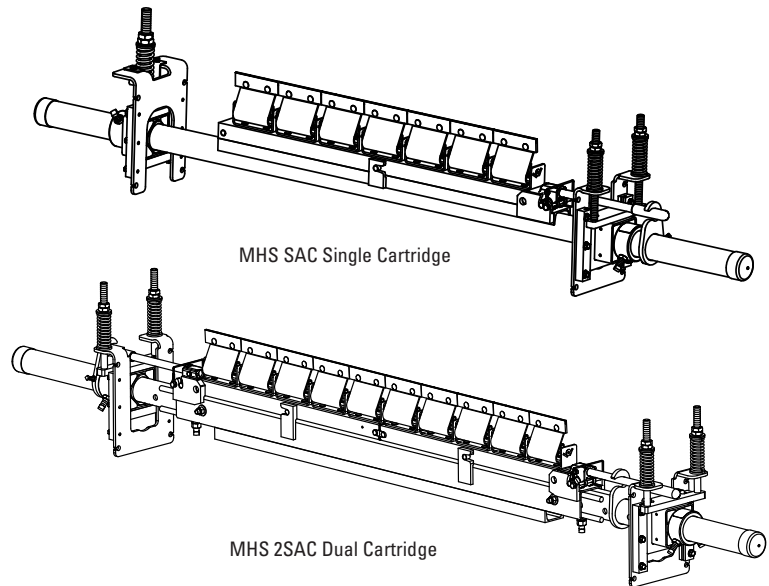

Replacement Tips

ORDERING NUMBER	ITEM CODE	WT. KG.
CT6 (C-Tip)	74535	0.4
RSA150 (V-Tip)	73628	0.4

Tips Required Per Cleaner Size

BELT WIDTH mm	BLADE COVERAGE mm	V-TIPS REQUIRED
600	600	4
750	750	5
900	900	6
1050	1050	7
1200	1200	8
1350	1350	9
1500	1500	10
1800	1800	12
2100	2100	14
2400	2400	16
3000	3000	20

Stock items (non-shaded) refer to (*) for specific lead time, if not specified, standard lead time applies.

Non-stock items (shaded) please contact Flexco for dispatch options and lead times.

Product Ordering Information

MHS SAC
HD Secondary Cleaner
with Service Advantage Cartridge™

MHS SAC Cartridge Kits with V-Tips*

BELT WIDTH mm	ORDERING NUMBER	ITEM CODE	WT. KG.
600	MHS-CARK-V24/600	77937	13.3
750	MHS-CARK-V30/750	77938	15.9
900	MHS-CARK-V36/900	77939	18.5
1050	MHS-CARK-V42/1050	77940	21.1
1200	MHS-CARK-V48/1200	77941	23.7
1350	MHS-CARK-V54/1350	77942	26.3
1500	MHS-CARK-V60/1500	77943	28.9
1800	MHS-CARK-V72/1800	77944	34.2
1500	MHS-CARK2-V60/1500	77950	31.8
1800	MHS-CARK2-V72/1800	77951	37.0
2100	MHS-CARK2-V84/2100	77952	42.2
2400	MHS-CARK2-V96/2400	77953	47.4
3000	MHS-CARK2-V120/3000	77954	57.9

*NOTE: V-Tips can be used ONLY on vulcanised belts.

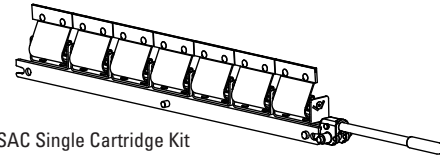

MHS SAC Single Cartridge Kit

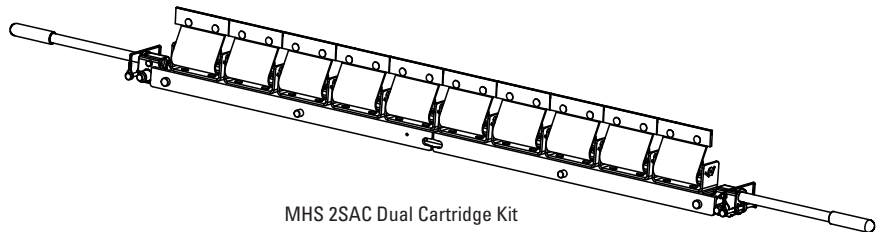

MHS 2SAC Dual Cartridge Kit

MHS SAC Stainless Steel Cartridge Kits with V-Tips*

BELT WIDTH mm	ORDERING NUMBER	ITEM CODE	WT. KG.
600	MHS-CARK-V24/600-S/S MVECKS/S	82841	13.3
750	MHS-CARK-V30/750-S/S MVECKS/S	82842	15.9
900	MHS-CARK-V36/900-S/S MVECKS/S	82843	18.5
1050	MHS-CARK-V42/1050-S/S MVECKS/S	82844	21.1
1200	MHS-CARK-V48/1200-S/S MVECKS/S	82845	23.7
1350	MHS-CARK-V54/1350-S/S MVECKS/S	82846	26.3
1500	MHS-CARK-V60/1500-S/S MVECKS/S	82847	28.9
1800	MHS-CARK-V72/1800-S/S MVECKS/S	82848	34.2
1500	MHS-CARK2-V60/1500-S/S MV2CKSS	82849	31.8
1800	MHS-CARK2-V72/1800-S/S MV2CKSS	82850	37.0
2100	MHS-CARK2-V84/2100-S/S MV2CKSS	82851	42.2
2400	MHS-CARK2-V96/2400-S/S MV2CKSS	82852	47.4
3000	MHS-CARK2-V120/3000-S/S MV2CKS	82853	57.9

*NOTE: V-Tips can be used ONLY on vulcanised belts.

Stock items (non-shaded) refer to (*) for specific lead time, if not specified, standard lead time applies.

Non-stock items (shaded) please contact Flexco for dispatch options and lead times.

U.S. Patent Pending

www.flexco.com • toll-free phone: +1300-098-435



Replacement Parts List

MHS SAC (Mild Steel) HD Secondary Cleaner with Service Advantage Cartridge™

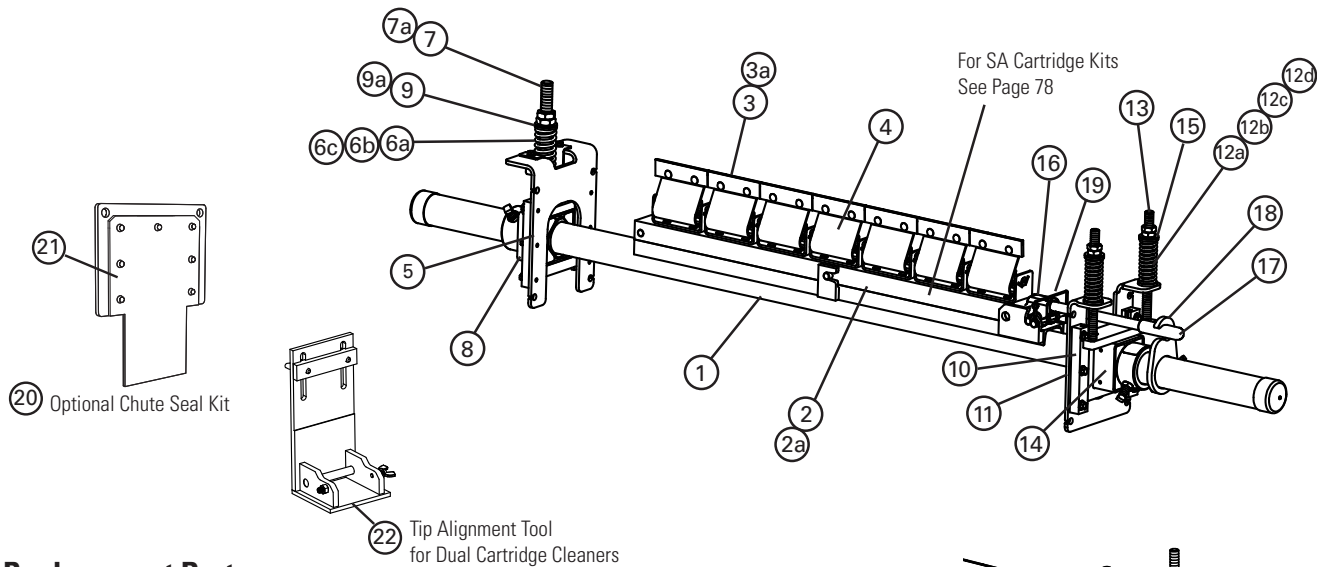

Replacement Parts

REF	DESCRIPTION	ORDERING NUMBER	ITEM CODE	WT. KG.
1	SAC Cartridge Pole 600mm	SACPL-24/600	77887	29.7
	SAC Cartridge Pole 750mm	SACPL-30/750	77888	32.3
	SAC Cartridge Pole 900mm	SACPL-36/900	77889	35.0
	SAC Cartridge Pole 1050mm	SACPL-42/1050	77890	37.6
	SAC Cartridge Pole 1200mm	SACPL-48/1200	77891	40.3
	SAC Cartridge Pole 1350mm	SACPL-54/1350	77892	42.9
	SAC Cartridge Pole 1500mm	SACPL-60/1500	77893	45.6
	SAC Cartridge Pole 1800mm	SACPL-72/1800	77894	50.9
	SAC Cartridge Center Pole 1500mm (Dual)	SACPL2-60/1500	77895	35.1
	SAC Cartridge Center Pole 1800mm (Dual)	SACPL2-72/1800	77896	40.6
	SAC Cartridge Center Pole 2100mm (Dual)	SACPL2-84/2100	77897	46.2
	SAC Cartridge Center Pole 2400mm (Dual)	SACPL2-96/2400	77898	51.8
	SAC Cartridge Center Pole 3000mm (Dual)	SACPL2-120/3000	77899	64.5
1a	Extender Pole (for use with Dual Cartridge Center Pole)	MHP-EP	76392	24.5
2	SAC Repl Cartridge S/S 600 mm	CART-24/600-S/S	78576	4.5
	SAC Repl Cartridge S/S 750 mm	CART-30/750-S/S	78577	5.6
	SAC Repl Cartridge S/S 900 mm	CART-36/900-S/S	78578	6.7
	SAC Repl Cartridge S/S 1050 mm	CART-42/1050-S/S	78579	7.8
	SAC Repl Cartridge S/S 1200 mm	CART-48/1200-S/S	78580	8.9
	SAC Repl Cartridge S/S 1350 mm	CART-54/1350-S/S	78581	10.0
	SAC Repl Cartridge S/S 1500 mm	CART-60/1500-S/S	78582	11.3
	SAC Repl Cartridge S/S 1800 mm	CART-72/1800-S/S	78583	13.5
	SAC Repl Cartridge S/S 1500 mm (Dual)	CART2-60/1500-S/S	78584	11.2
	SAC Repl Cartridge S/S 1800 mm (Dual)	CART2-72/1800-S/S	78585	13.4
	SAC Repl Cartridge S/S 1950 mm (Dual)	CART2-78/1950-S/S	78635	14.5
	SAC Repl Cartridge S/S 2100 mm (Dual)	CART2-84/2100-S/S	78586	15.6
	SAC Repl Cartridge S/S 2400 mm (Dual)	CART2-96/2400-S/S	78587	17.8
SAC Repl Cartridge S/S 3000 mm (Dual)	CART2-120/3000-S/S	78588	22.6	
3	C-Tip*	CT6	74535	0.4
3a	V-Tip* (for vulcanised belts only)	RSA150	73628	0.4
4	PowerFlex™ Cushion*	SPFC	79200	0.9
5	SST HD Mounting Base Kit* (includes 1 mounting base and 2 slide guides)	SSTHDMK	77870	4.6

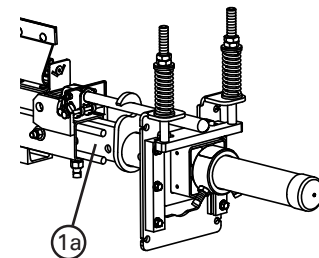

Dual cartridge model only

Stock items (non-shaded) refer to (*) for specific lead time, if not specified, standard lead time applies.
Non-stock items (shaded) please contact Flexco for dispatch options and lead times.

Replacement Parts List

MHS SAC (Mild Steel) HD® Secondary Cleaner with Service Advantage Cartridge™

Replacement Parts (continued)

REF	DESCRIPTION	ORDERING NUMBER	ITEM CODE	WT. KG.
6a	SST Spring - White (1 ea.) for belts 450-750mm	STS-W	75846	0.2
6b	SST Spring - Silver (1 ea.) for belts 900-1500mm	STS-S	75843	0.4
6c	SST Spring - Black (1 ea.) for belts 1800-2100mm	STS-B	75844	0.5
6d	SST Spring - Gold (1 ea.) for belts over 2100mm	STS-G	78142	0.7
7	SST Adj Rod Kit*(incl. 1 rod, 2 nuts, 2 bushings, 1 washer) for belts 450-1500 mm	STAK	75847	1.3
7a	SST HD® Adj Rod Kit*(incl. 1 rod, 2 nuts, 2 HD bushings, 1 washer) for belts 1800-2100mm	STAKHD	75892	1.4
8	SST HD Torsion Pole Mount* (1 ea.)	SSTHDPM	77868	6.8
9	SST Bushing Kit - White/Silver	SSTBK-W	76636	0.1
9a	SST Bushing Kit - Black	SSTBK-B	76637	0.1
10	ST Slide Guide Kit	STGK2	77635	0.5
-	SST HD Cartridge Tensioner - White (includes 1 ea. item 5, 6a, 7, 8) for belts 450-750 mm	SST1HDM-W	78517	13.7
-	SST HD Cartridge Tensioner - Silver (includes 1 ea. item 5, 6b, 7, 8) for belts 900-1500 mm	SST1HDM-S	78518	13.9
-	SST HD Cartridge Tensioner - Black (includes 1 ea. item 5, 6c, 7a, 8) for belts 1800-2100 mm	SST1HDM-B	78519	14.1
-	SST HD Cartridge Tensioner - Gold (includes 1 ea. item 5, 6d, 7a, 8) for belts over 2100 mm	SST1HDM-G	79069	14.3
11	CST HD Mounting Base Kit*	CSTHDMK	77871	3.9
12a	CST Spring - White (1 ea.) for belts 450-750 mm	CTS-W	77742	0.2
12b	CST Spring - Silver (1 ea.) for belts 900-1500 mm	CTS-S	77743	0.2
12c	CST Spring - Black (1 ea.) for belts 1800-2100 mm	CTS-B	77744	0.3
12d	CST Spring - Gold (1 ea.) for belts 2400-3000 mm	CTS-G	77745	0.4

REF	DESCRIPTION	ORDERING NUMBER	ITEM CODE	WT. KG.
13	CST Adj Rod Kit (incl. 2 rods, 4 nuts, 4 bushings, 2 washers)	CSTAK	77031	1.5
14	CST HD Torsion Pole Mount* (1 ea.)	CSTHDPM	77869	7.4
15	CST Bushing Kit (includes 4 bushings)	CSTBK	77037	0.1
-	CST HD Cartridge Tensioner - White (incl. 1 ea. item 11,13,14 and 2 ea. item 12) for belts 450-750 mm	CST1HDM-W	78513	13.7
-	CST HD Cartridge Tensioner - Silver (incl. 1 ea. item 11,13,14 and 2 ea. item 12a) for belts 900-1500 mm	CST1HDM-S	78514	13.7
-	CST HD Cartridge Tensioner - Black (includes 1 ea. item 11,13,14 and 2 ea. item 12b) for belts 1800-2100 mm	CST1HDM-B	78515	13.7
-	CST HD Cartridge Tensioner - Gold (includes 1 ea. item 11,13,14 and 2 ea. item 12c) for belts 2400-3000 mm	CST1HDM-G	78516	13.9
16	SAC Removal Knuckle	SACRKN	77882	1.5
17	SAC Removal Handle	SACRH	77883	1.4
18	SAC Handle Lock Plate	SACRHL	77884	0.8
19	Knuckle Retainer Pin	SACKRP	77885	0.1
-	SAC Removal Kit (includes 1 ea. items 16,17,18,19)	SACRKT	77886	4.1
20	SAC Chute Seal Kit	SACSK	77052	1.8
21	SAC Chute Seal Replacement Cover	SACSRC	77065	0.2
22	SAC Cartridge Tip Alignment Tool (Dual)	SAC2-TIP-TL	77866	1.1

ATV Replacement Parts

REF	DESCRIPTION	ORDERING NUMBER	ITEM CODE	WT. KG.
1	Mounting Bracket LH	PMBL-S/S	75518	3.8
2	Mounting Bracket RH	PMBR-S/S	75521	3.8
3	Air Tensioner Slider	ATV-SLIDE	62425	0.2
4	Air Tension Cradle Blocks 60mm Kit	ATV-MOUNT	62424	2.4
5	Air Tension Cradle Blocks 73mm Kit	ATV-MOUNT	63073	2.4
6	Air Tension Adjusting Angle	ATV-ANGLE	62426	1.0
7	Air Bag	ATV-BAG	62079	0.2
8	Hex Nut S/S	HEX NUT	G1211	0.1
9	Air Line Adaptor	ATV-NIP	62037	0.1
10	PAT Control Box 60psi	PACB60	78683	5.0
11	PAT Control Box 100psi	PACB100	79656	5.0
-	Secondary Air Tension 60mm Complete Kit	ATVK-60	62409	13.0
-	Secondary Air Tension 73mm Complete Kit	ATVK-73	63072	15.0

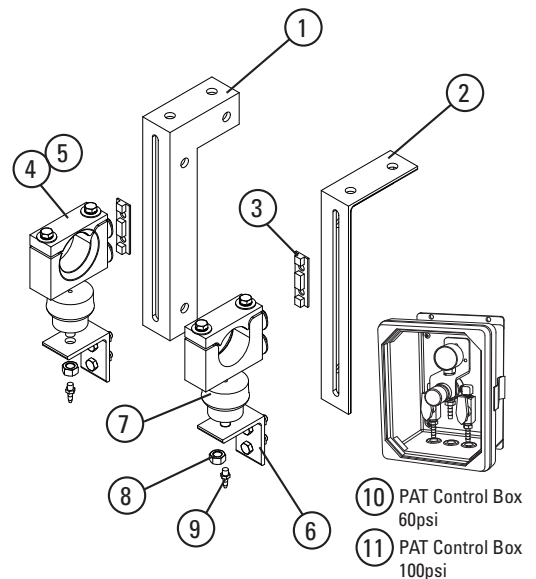

Stock items (non-shaded) refer to (*) for specific lead time, if not specified, standard lead time applies.
Non-stock items (shaded) please contact Flexco for dispatch options and lead times.

Replacement Parts List

MHS SAC (Stainless Steel) HD® Secondary Cleaner with Service Advantage Cartridge™

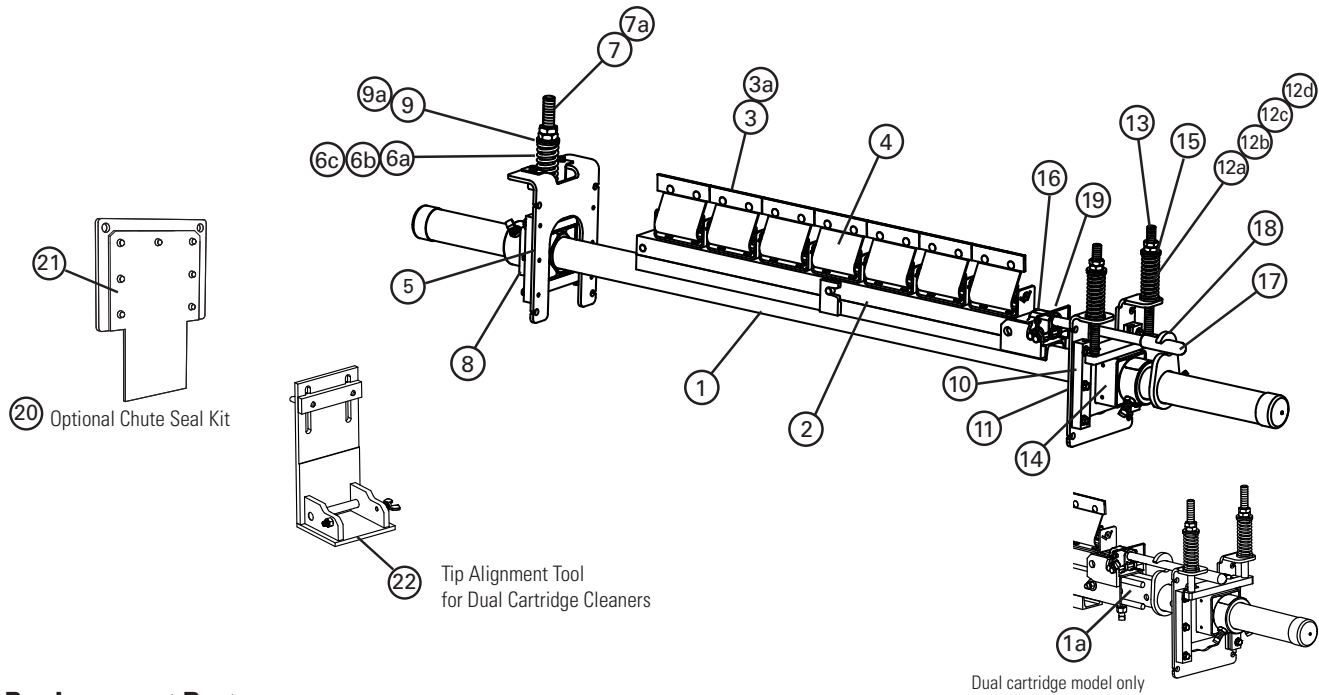

Replacement Parts

REF	DESCRIPTION	ORDERING NUMBER	ITEM CODE	WT. KG.	
1	SAC S/S Cartridge Pole 600mm	SACPL-24/600-S/S	78371	29.7	
	SAC S/S Cartridge Pole 750mm	SACPL-30/750-S/S	78372	32.3	
	SAC S/S Cartridge Pole 900mm	SACPL-36/900-S/S	78373	35.0	
	SAC S/S Cartridge Pole 1050mm	SACPL-42/1050-S/S	78374	37.6	
	SAC S/S Cartridge Pole 1200mm	SACPL-48/1200-S/S	78375	40.3	
	SAC S/S Cartridge Pole 1350mm	SACPL-54/1350-S/S	78376	42.9	
	SAC S/S Cartridge Pole 1500mm	SACPL-60/1500-S/S	78377	45.6	
	SAC S/S Cartridge Pole 1800mm	SACPL-72/1800-S/S	78378	50.9	
	SAC S/S Cartridge Center Pole 1500mm (Dual)	SACPL2-60/1500-S/S	78379	35.1	
	SAC S/S Cartridge Center Pole 1800mm (Dual)	SACPL2-72/1800-S/S	78380	40.6	
	SAC S/S Cartridge Center Pole 1950mm (Dual)	SACPL2-78/1950-S/S	78642	43.9	
	SAC S/S Cartridge Center Pole 2100mm (Dual)	SACPL2-84/2100-S/S	78381	46.2	
	SAC S/S Cartridge Center Pole 2400mm (Dual)	SACPL2-96/2400-S/S	78382	51.8	
	SAC S/S Cartridge Center Pole 3000mm (Dual)	SACPL2-120/3000-S/S	78383	64.5	
	1a	S/S Extender Pole (for use with S/S Dual Cartridge Center Pole)	MHP-EP-S/S	77599	24.5

REF	DESCRIPTION	ORDERING NUMBER	ITEM CODE	WT. KG.
2	SAC Repl Cartridge S/S 600 mm	CART-24/600-S/S	78576	4.5
	SAC Repl Cartridge S/S 750 mm	CART-30/750-S/S	78577	5.6
	SAC Repl Cartridge S/S 900 mm	CART-36/900-S/S	78578	6.7
	SAC Repl Cartridge S/S 1050 mm	CART-42/1050-S/S	78579	7.8
	SAC Repl Cartridge S/S 1200 mm	CART-48/1200-S/S	78580	8.9
	SAC Repl Cartridge S/S 1350 mm	CART-54/1350-S/S	78581	10.0
	SAC Repl Cartridge S/S 1500 mm	CART-60/1500-S/S	78582	11.3
	SAC Repl Cartridge S/S 1800 mm	CART-72/1800-S/S	78583	13.5
	SAC Repl Cartridge S/S 1500 mm (Dual)	CART2-60/1500-S/S	78584	11.2
	SAC Repl Cartridge S/S 1800 mm (Dual)	CART2-72/1800-S/S	78585	13.4
	SAC Repl Cartridge S/S 1950 mm (Dual)	CART2-78/1950-S/S	78635	14.5
	SAC Repl Cartridge S/S 2100 mm (Dual)	CART2-84/2100-S/S	78586	15.6
	SAC Repl Cartridge S/S 2400 mm (Dual)	CART2-96/2400-S/S	78587	17.8
	SAC Repl Cartridge S/S 3000 mm (Dual)	CART2-120/3000-S/S	78588	22.6

Stock items (non-shaded) refer to (*) for specific lead time, if not specified, standard lead time applies.

Non-stock items (shaded) please contact Flexco for dispatch options and lead times.

Replacement Parts List

MHS SAC (Stainless Steel)
HD® Secondary Cleaner
 with Service Advantage Cartridge™

Replacement Parts (continued)

REF	DESCRIPTION	ORDERING NUMBER	ITEM CODE	WT. KG.
3	C-Tip	CT6	74535	0.4
3a	S/S V-Tip* (for vulcanised belts only)	RVT6-S/S	76205	0.4
4	PowerFlex™ Cushion, S/S*	SPFC-S/S	79201	0.9
5	SST HD® Mounting Base Kit, S/S*	STHDMK2-S/S	77634	4.6
6a	SST Spring - White S/S (1 ea.)	STS-W-S/S	77630	0.2
6b	SST Spring - Silver S/S (1 ea.)	STS-S-S/S	77631	0.4
6c	SST Spring - Black S/S (1 ea.)	STS-B-S/S	77632	0.5
7	SST Adj Rod Kit*(incl. 1 rod, 2 nuts, 2 bushings, 1 washer) for belts 450-1500 mm	STAK	75847	1.3
7a	SST HD Adj Rod Kit*(incl. 1 rod, 2 nuts, 2 HD bushings, 1 washer) for belts 1800-2100mm	STAKHD	75892	1.4
8	SST HD Torsion Pole Mount S/S* (1 ea.)	STHDPM2-S/S	77633	6.8
9	SST Bushing Kit - White/Silver	SSTBK-W	76636	0.1
9a	SST Bushing Kit - Black	SSTBK-B	76637	0.1
10	ST Slide Guide Kit	STGK2	77635	0.5
-	SST HD Cartridge Tensioner S/S - White (includes 1 ea. item 5, 6a, 7, 9) for belts 450-750 mm	SST1HDM-W-S/S	78394	13.7
-	SST HD Cartridge Tensioner S/S - Silver (includes 1 ea. item 5, 6b, 7, 9) for belts 900-1500 mm	SST1HDM-S-S/S	78395	13.9
-	SST HD Cartridge Tensioner S/S - Black (includes 1 ea. item 5, 6c, 7a, 9a) for belts 1800-2100 mm	SST1HDM-B-S/S	78396	14.1
11	CST HD Mounting Base Kit S/S*	CSTHDMK-S/S	78384	3.9
12a	CST Spring - White S/S (1 ea.) for belts 450-750 mm	CTS-W-S/S	78385	0.2
12b	CST Spring - Silver S/S (1 ea.) for belts 900-1500 mm	CTS-S-S/S	78386	0.2
12c	CST Spring - Black S/S (1 ea.) for belts 1800-2100 mm	CTS-B-S/S	78387	0.3
12d	CST Spring - Gold S/S (1 ea.) for belts 2400-3000 mm	CTS-G-S/S	78388	0.4
13	CST Adj Rod Kit (incl. 2 rods, 4 nuts, 4 bushings, 2 washers)	CSTAK	77031	1.5
14	CST HD Torsion Pole Mount S/S* (1 ea.)	CSTHDPM-S/S	78389	7.4
15	CST Bushing Kit (includes 4 bushings)	CSTBK	77037	0.1
-	CST HD Cartridge Tensioner S/S - White (incl. 1 ea. item 11,13,14 and 2 ea. item 12a) for belts 450-750 mm	CST1HDM-W-S/S	78390	13.7
-	CST HD Cartridge Tensioner S/S - Silver (incl. 1 ea. item 11,13,14 and 2 ea. item 12b) for belts 900-1500 mm	CST1HDM-S-S/S	78391	13.7
-	CST HD Cartridge Tensioner S/S - Black (includes 1 ea. item 11,13,14 and 2 ea. item 12c) for belts 1800-2100 mm	CST1HDM-B-S/S	78392	13.7
-	CST HD Cartridge Tensioner S/S - Gold (includes 1 ea. item 11,13,14 and 2 ea. item 12d) for belts 2400-3000 mm	CST1HDM-G-S/S	78393	13.9
16	SAC Removal Knuckle	SACRKN	77882	1.5
17	SAC Removal Handle S/S	SACRH-S/S	78397	1.4
18	SAC Handle Lock Plate S/S	SACRHL-S/S	78398	0.8
19	Knuckle Retainer Pin S/S	SACKRP-S/S	78399	0.1
-	SAC Removal Kit S/S (includes 1 ea. items 16,17,18,19)	SACRKT-S/S	78401	4.1
20	SAC Chute Seal Kit	SACSK	77052	1.8
21	SAC Chute Seal Replacement Cover	SACSRC	77065	0.2
22	SAC Cartridge Tip Alignment Tool (Dual)	SAC2-TIP-TL	77866	1.1

Stock items (non-shaded) refer to (*) for specific lead time, if not specified, standard lead time applies.

Non-stock items (shaded) please contact Flexco for dispatch options and lead times.

Specifications & Guidelines

MHS SAC
HD® Secondary Cleaner
 with Service Advantage Cartridge™

Pole Length Specifications*

VERSION	CLEANER SIZE mm	BLADE WIDTH mm	POLE LENGTH mm	MAXIMUM CONVEYOR SPAN mm
Single	600	600	1950	1650
	750	750	2100	1800
	900	900	2250	1950
	1050	1050	2400	2100
	1200	1200	2550	2250
	1350	1350	2700	2400
	1500	1500	2850	2550
Dual	1500	1500	3000	2700
	1800	1800	3300	3000
	2100	2100	3600	3300
	2400	2400	3900	3600
	3000	3000	4500	4200

*For special extra long pole length requirements a Pole Extender Kit (#76024) is available that provides 750 mm of extended pole length. Pole Diameter - 73 mm

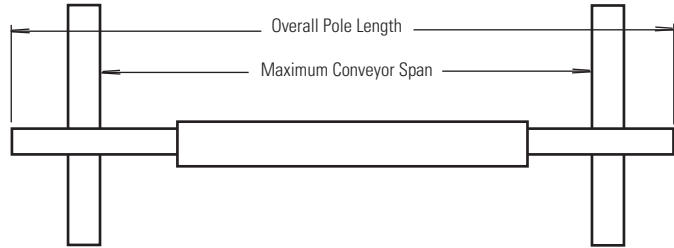

Clearance Guidelines for Installation

VERSION	HORIZONTAL CLEARANCE REQUIRED mm	VERTICAL CLEARANCE REQUIRED mm
Single	114	279
Dual	114	318

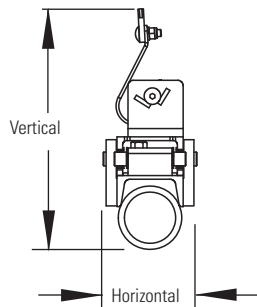

Aluminum Content

ALUMINUM ALLOY TYPE	PERCENT	
	MG MAGNESIUM	TI TITANIUM
6061	1.0%	0.0%

Spring Length Chart for SST Spring Tensioner (mm)

BLADE WIDTH	WHITE SPRING	SILVER SPRING	BLACK SPRING
600	78	99	N/A
750	72	97	N/A
900	N/A	94	98
1050	N/A	91	95
1200	N/A	88	93
1350	N/A	86	91
1500	N/A	83	89
1800	N/A	N/A	84

Shading indicates preferred spring option

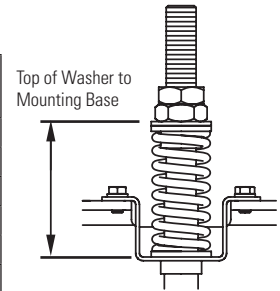

Spring Length Chart for CST Spring Tensioner (mm)

BLADE WIDTH	WHITE SPRING	SILVER SPRING	BLACK SPRING	GOLD SPRING
600	78	99	N/A	N/A
750	72	97	N/A	N/A
900	N/A	94	98	N/A
1050	N/A	91	95	N/A
1200	N/A	88	93	N/A
1350	N/A	86	91	N/A
1500	N/A	83	89	103
1800	N/A	N/A	84	101
2100	N/A	N/A	80	99
2400	N/A	N/A	N/A	97
3000	N/A	N/A	N/A	93

Shading indicates preferred spring option

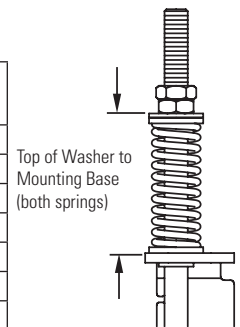

Specifications:

- Maximum Belt Speed 6M/sec
- Temperature Rating..... -35°C to 82°C
- Usable Blade Wear Length..... 9mm
- Blade Materials..... C-Tip: Impact Resistant Tungsten Carbide (works with mechanical fasteners)
 V-Tip: Long Life Tungsten Carbide (for vulcanised belts only)
- Available for Belt Widths..... 600 to 3000 mm. Other sizes available upon request.

U.S. Patent Pending

Product Ordering Information

MHS SAC BT HD® Secondary Cleaner with Service Advantage Cartridge™ & Bolt Tensioner

MHS SAC Secondary with V-Tips*

BELT WIDTH mm	ORDERING NUMBER	ITEM CODE	WT. KG.
600	MHS-600BTV-SAC	78007	61.4
750	MHS-750BTV-SAC	78008	66.4
900	MHS-900BTV-SAC	78009	71.6
1050	MHS-1050BTV-SAC	78010	77.2
1200	MHS-1200BTV-SAC	78011	82.0
1350	MHS-1350BTV-SAC	78012	87.1
1500	MHS-1500BTV-SAC	78013	92.4
1800	MHS-1800BTV-SAC	78014	102.7
1500	MHS-1500BTV-2SAC	78015	105.2
1800	MHS-1800BTV-2SAC	78016	120.7
2100	MHS-2100BTV-2SAC	78017	131.4
2400	MHS-2400BTV-2SAC	78018	142.0
3000	MHS-3000BTV-2SAC	78019	165.0

*NOTE: V-Tips can be used ONLY on vulcanised belts.

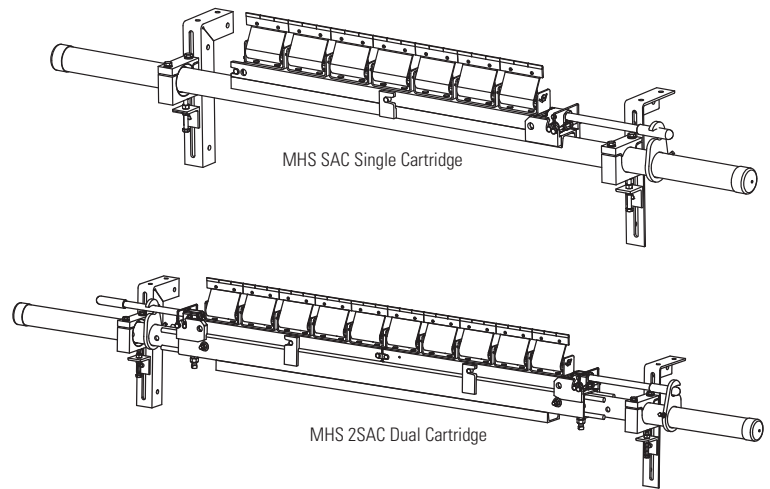

MHS SAC Stainless Steel Secondary with V-Tips*

BELT WIDTH mm	ORDERING NUMBER	ITEM CODE	WT. KG.
600	MHS-600BTV-SAC-S/S	78316	61.4
750	MHS-750BTV-SAC-S/S	78317	66.4
900	MHS-900BTV-SAC-S/S	78318	71.6
1050	MHS-1050BTV-SAC-S/S	78319	77.2
1200	MHS-1200BTV-SAC-S/S	78320	82.0
1350	MHS-1350BTV-SAC-S/S	78321	87.1
1500	MHS-1500BTV-SAC-S/S	78322	92.4
1800	MHS-1800BTV-SAC-S/S	78323	102.7
1500	MHS-1500BTV-2SAC-S/S	78324	105.2
1800	MHS-1800BTV-2SAC-S/S	78325	120.7
1950	MHS-1950BTV-2SAC-S/S	78649	126.0
2100	MHS-2100BTV-2SAC-S/S	78326	131.4
2400	MHS-2400BTV-2SAC-S/S	78327	142.0
3000	MHS-3000BTV-2SAC-S/S	78328	165.0

*NOTE: V-Tips can be used ONLY on vulcanised belts.

Replacement Tips

ORDERING NUMBER	ITEM CODE	WT. KG.
RSA150 (V-Tip)	73628	0.4

Tips Required Per Cleaner Size

BELT WIDTH mm	BLADE COVERAGE mm	V-TIPS REQUIRED
600	600	4
750	750	5
900	900	6
1050	1050	7
1200	1200	8
1350	1350	9
1500	1500	10
1800	1800	12
2100	2100	14
2400	2400	16
3000	3000	20

Product Notes:

- Patent-pending Service Advantage Cartridge™ allows for easy removal in even the dirtiest conditions.
- Heavy-duty design to deliver maximum cleaning efficiency on the most demanding, abusive beltlines.
- Pole Length: Belt width plus 1350mm (single cartridge cleaners); Belt width plus 1500 mm (dual cartridge cleaners).
- Patented PowerFlex™ cushion design to maintain continuous blade-to-belt contact and quick relief from passing mechanical splices.
- C-Tips are for mechanically fastened or vulcanised belts. V-Tips are for vulcanised belts only.
- Visual Blade Tension Check: Measure the tension spring and refer to Spring Length Chart on mounting base for the correct length for best cleaning performance.
- Tensioner mounting brackets included for fast and easy installation.
- Cartridge Removal Kit included for easy removal of the cartridge.

U.S. Patent Pending

Stock items (non-shaded) refer to (*) for specific lead time, if not specified, standard lead time applies.

Non-stock items (shaded) please contact Flexco for dispatch options and lead times.

Product Ordering Information

MHS SAC BT HD® Secondary Cleaner with Service Advantage Cartridge™ & Bolt Tensioner

MHS SAC Cartridge Kits with V-Tips*

BELT WIDTH mm	ORDERING NUMBER	ITEM CODE	WT. KG.
600	MHS-CARK-V24/600	77937	13.3
750	MHS-CARK-V30/750	77938	15.9
900	MHS-CARK-V36/900	77939	18.5
1050	MHS-CARK-V42/1050	77940	21.1
1200	MHS-CARK-V48/1200	77941	23.7
1350	MHS-CARK-V54/1350	77942	26.3
1500	MHS-CARK-V60/1500	77943	28.9
1800	MHS-CARK-V72/1800	77944	34.2
1500	MHS-CARK2-V60/1500	77950	31.8
1800	MHS-CARK2-V72/1800	77951	37.0
2100	MHS-CARK2-V84/2100	77952	42.2
2400	MHS-CARK2-V96/2400	77953	47.4
3000	MHS-CARK2-V120/3000	77954	57.9

*NOTE: V-Tips can be used ONLY on vulcanised belts.

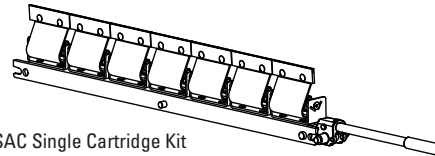

MHS SAC Single Cartridge Kit

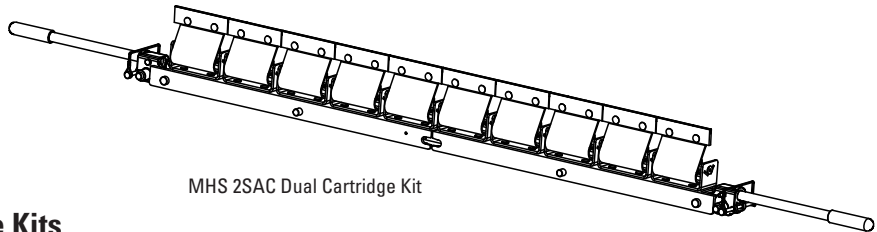

MHS 2SAC Dual Cartridge Kit

MHS SAC Stainless Steel Cartridge Kits with V-Tips*

BELT WIDTH mm	ORDERING NUMBER	ITEM CODE	WT. KG.
600	MHS-CARK-V24/600-S/S MVECKS/S	82841	13.3
750	MHS-CARK-V30/750-S/S MVECKS/S	82842	15.9
900	MHS-CARK-V36/900-S/S MVECKS/S	82843	18.5
1050	MHS-CARK-V42/1050-S/S MVECKS/S	82844	21.1
1200	MHS-CARK-V48/1200-S/S MVECKS/S	82845	23.7
1350	MHS-CARK-V54/1350-S/S MVECKS/S	82846	26.3
1500	MHS-CARK-V60/1500-S/S MVECKS/S	82847	28.9
1800	MHS-CARK-V72/1800-S/S MVECKS/S	82848	34.2
1500	MHS-CARK2-V60/1500-S/S MV2CKSS	82849	31.8
1800	MHS-CARK2-V72/1800-S/S MV2CKSS	82850	37.0
2100	MHS-CARK2-V84/2100-S/S MV2CKSS	82851	42.2
2400	MHS-CARK2-V96/2400-S/S MV2CKSS	82852	47.4
3000	MHS-CARK2-V120/3000-S/S MV2CKS	82853	57.9

*NOTE: V-Tips can be used ONLY on vulcanised belts.

Stock items (non-shaded) refer to (*) for specific lead time, if not specified, standard lead time applies.

Non-stock items (shaded) please contact Flexco for dispatch options and lead times.

Replacement Parts List

MHS SAC BT (Mild Steel) HD® Secondary Cleaner with Service Advantage Cartridge™ & Bolt Tensioner

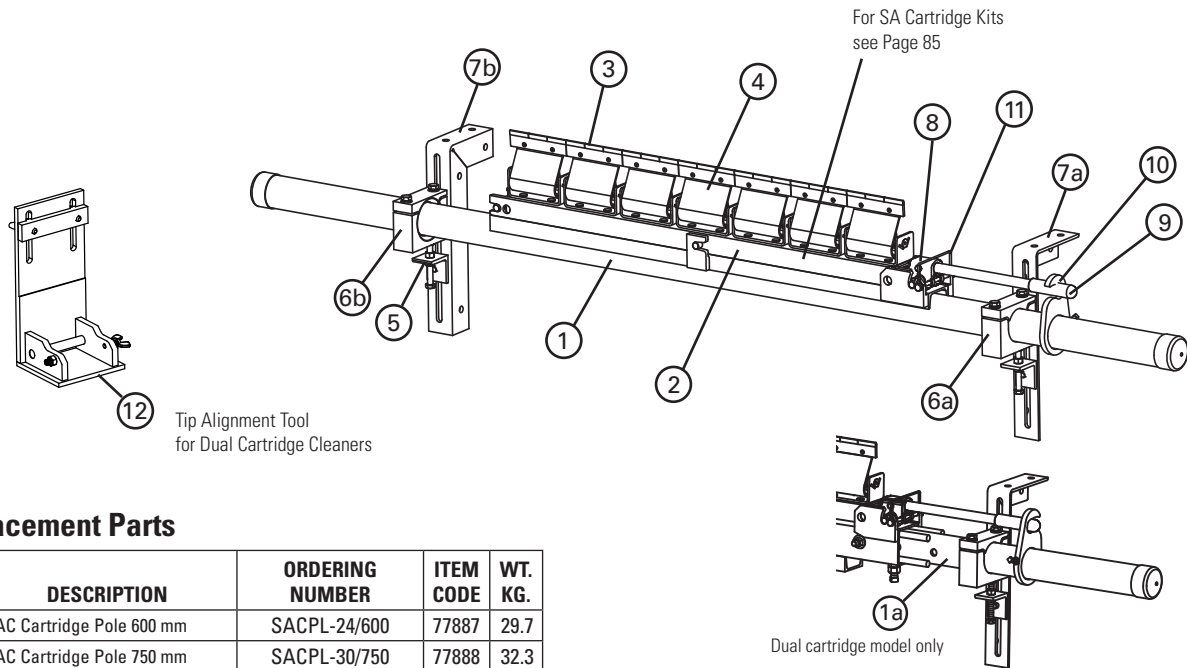

Replacement Parts

REF	DESCRIPTION	ORDERING NUMBER	ITEM CODE	WT. KG.
1	SAC Cartridge Pole 600 mm	SACPL-24/600	77887	29.7
	SAC Cartridge Pole 750 mm	SACPL-30/750	77888	32.3
	SAC Cartridge Pole 900 mm	SACPL-36/900	77889	35.0
	SAC Cartridge Pole 1050 mm	SACPL-42/1050	77890	37.6
	SAC Cartridge Pole 1200 mm	SACPL-48/1200	77891	40.3
	SAC Cartridge Pole 1350 mm	SACPL-54/1350	77892	42.9
	SAC Cartridge Pole 1500 mm	SACPL-60/1500	77893	45.6
	SAC Cartridge Pole 1800 mm	SACPL-72/1800	77894	50.9
	SAC Cartridge Center Pole 1500 mm (Dual)	SACPL2-60/1500	77895	35.1
	SAC Cartridge Center Pole 1800 mm (Dual)	SACPL2-72/1800	77896	40.6
	SAC Cartridge Center Pole 2100 mm (Dual)	SACPL2-84/2100	77897	46.2
	SAC Cartridge Center Pole 2400 mm (Dual)	SACPL2-96/2400	77898	51.8
	SAC Cartridge Center Pole 3000 mm (Dual)	SACPL2-120/3000	77899	64.5
1a	Extender Pole (for use with Dual Cartridge Center Pole)	MHP-EP	76392	24.5
2	SAC Repl Cartridge S/S 600 mm	CART-24/600-S/S	78576	4.5
	SAC Repl Cartridge S/S 750 mm	CART-30/750-S/S	78577	5.6
	SAC Repl Cartridge S/S 900 mm	CART-36/900-S/S	78578	6.7
	SAC Repl Cartridge S/S 1050 mm	CART-42/1050-S/S	78579	7.8
	SAC Repl Cartridge S/S 1200 mm	CART-48/1200-S/S	78580	8.9
	SAC Repl Cartridge S/S 1350 mm	CART-54/1350-S/S	78581	10.0
	SAC Repl Cartridge S/S 1500 mm	CART-60/1500-S/S	78582	11.3
	SAC Repl Cartridge S/S 1800 mm	CART-72/1800-S/S	78583	13.5
	SAC Repl Cartridge S/S 1500 mm (Dual)	CART2-60/1500-S/S	78584	11.2
	SAC Repl Cartridge S/S 1800 mm (Dual)	CART2-72/1800-S/S	78585	13.4
	SAC Repl Cartridge S/S 1950 mm (Dual)	CART2-78/1950-S/S	78635	14.5
	SAC Repl Cartridge S/S 2100 mm (Dual)	CART2-84/2100-S/S	78586	15.6
	SAC Repl Cartridge S/S 2400 mm (Dual)	CART2-96/2400-S/S	78587	17.8
	SAC Repl Cartridge S/S 3000 mm (Dual)	CART2-120/3000-S/S	78588	22.6

REF	DESCRIPTION	ORDERING NUMBER	ITEM CODE	WT. KG.
3	V-Tip* (for vulcanised belts only)	RSA150	73628	0.4
4	PowerFlex™ Cushion*	SPFC	79200	0.9
5	P/R Adjusting Bracket	PAB	75513	0.4
6a	Cradle Clamp Block RH	SMR-CCB-R73	A2843	1.2
6b	Cradle Clamp Block LH	SMR-CCB-L73	A2842	1.2
7a	Mounting Bracket Kit RH	PMBR	75519	3.8
7b	Mounting Bracket Kit LH	PMBL	75516	3.8
8	SAC Removal Knuckle	SACRKN	77882	1.5
9	SAC Removal Handle	SACRH	77883	1.4
10	SAC Handle Lock Plate	SACRHL	77884	0.8
11	Knuckle Retainer Pin	SACKRP	77885	0.1
-	SAC Removal Kit (incl. 1 ea. items 8,9,10,11)	SACRKT	77886	4.1
12	SAC Cartridge Tip Alignment Tool (Dual)	SAC2-TIP-TL	77866	1.1
-	Cradle Clamp Heavy-Duty Mounting Kit (incl. 2 ea. items 5, 7; 1 ea. items 6a, 6b)	CRHMK	62400	10.8

Stock items (non-shaded) refer to (*) for specific lead time, if not specified, standard lead time applies.

Non-stock items (shaded) please contact Flexco for dispatch options and lead times.

Replacement Parts List

MHS SAC BT (Stainless Steel) HD[®] Secondary Cleaner with Service Advantage Cartridge™ & Bolt Tensioner

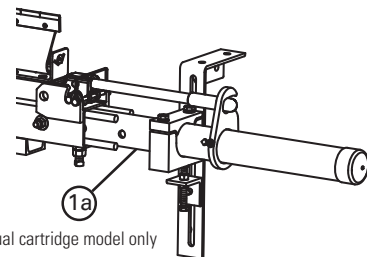
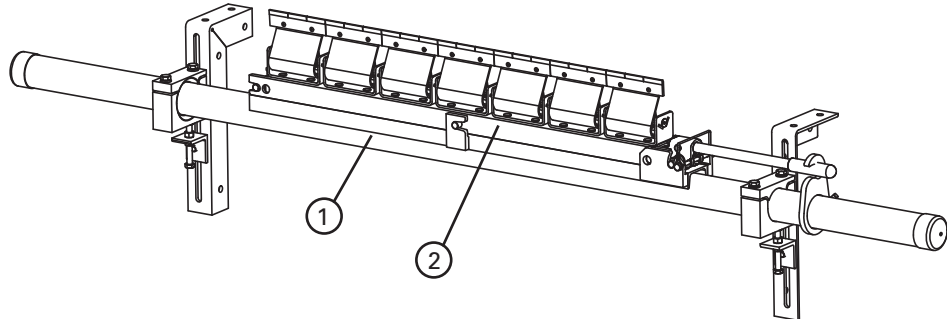

Replacement Parts

REF	DESCRIPTION	ORDERING NUMBER	ITEM CODE	WT. KG.
1	SAC S/S Cartridge Pole 600 mm	SACPL-24/600-S/S	78371	29.7
	SAC S/S Cartridge Pole 750 mm	SACPL-30/750-S/S	78372	32.3
	SAC S/S Cartridge Pole 900 mm	SACPL-36/900-S/S	78373	35.0
	SAC S/S Cartridge Pole 1050 mm	SACPL-42/1050-S/S	78374	37.6
	SAC S/S Cartridge Pole 1200 mm	SACPL-48/1200-S/S	78375	40.3
	SAC S/S Cartridge Pole 1350 mm	SACPL-54/1350-S/S	78376	42.9
	SAC S/S Cartridge Pole 1500 mm	SACPL-60/1500-S/S	78377	45.6
	SAC S/S Cartridge Pole 1800 mm	SACPL-72/1800-S/S	78378	50.9
	SAC S/S Cartridge Center Pole 1500 mm (Dual)	SACPL2-60/1500-S/S	78379	35.1
	SAC S/S Cartridge Center Pole 1800 mm (Dual)	SACPL2-72/1800-S/S	78380	40.6
	SAC S/S Cartridge Center Pole 1950 mm (Dual)	SACPL2-78/1950-S/S	78642	43.9
	SAC S/S Cartridge Center Pole 2100 mm (Dual)	SACPL2-84/2100-S/S	78381	46.2
	SAC S/S Cartridge Center Pole 2400 mm (Dual)	SACPL2-96/2400-S/S	78382	51.8
	SAC S/S Cartridge Center Pole 3000 mm (Dual)	SACPL2-120/3000-S/S	78383	64.5
1a	S/S Extender Pole (for use with S/S Dual Cartridge Center Pole)	MHP-EP-S/S	77599	24.5
2	SAC Repl Cartridge S/S 600 mm	CART-24/600-S/S	78576	4.5
	SAC Repl Cartridge S/S 750 mm	CART-30/750-S/S	78577	5.6
	SAC Repl Cartridge S/S 900 mm	CART-36/900-S/S	78578	6.7
	SAC Repl Cartridge S/S 1050 mm	CART-42/1050-S/S	78579	7.8
	SAC Repl Cartridge S/S 1200 mm	CART-48/1200-S/S	78580	8.9
	SAC Repl Cartridge S/S 1350 mm	CART-54/1350-S/S	78581	10.0
	SAC Repl Cartridge S/S 1500 mm	CART-60/1500-S/S	78582	11.3
	SAC Repl Cartridge S/S 1800 mm	CART-72/1800-S/S	78583	13.5

Stock items (non-shaded) refer to (*) for specific lead time, if not specified, standard lead time applies.

Non-stock items (shaded) please contact Flexco for dispatch options and lead times.

Replacement Parts List

MHS SAC BT (Stainless Steel) HD[®] Secondary Cleaner with Service Advantage Cartridge™ & Bolt Tensioner

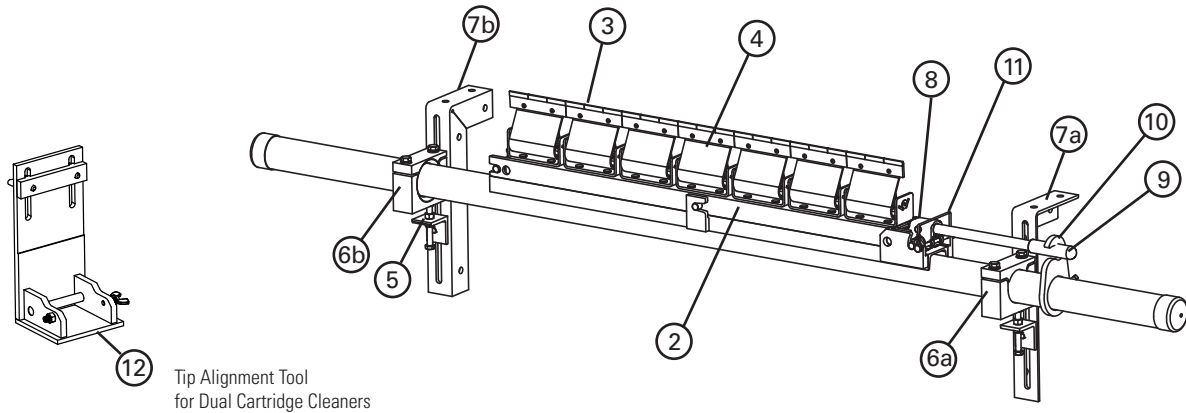

Tip Alignment Tool
for Dual Cartridge Cleaners

Replacement Parts (Continued)

REF	DESCRIPTION	ORDERING NUMBER	ITEM CODE	WT. KG.
2	SAC Repl Cartridge S/S 1500 mm (Dual)	CART2-60/1500-S/S	78584	11.2
	SAC Repl Cartridge S/S 1800 mm (Dual)	CART2-72/1800-S/S	78585	13.4
	SAC Repl Cartridge S/S 1950 mm (Dual)	CART2-78/1950-S/S	78635	14.5
	SAC Repl Cartridge S/S 2100 mm (Dual)	CART2-84/2100-S/S	78586	15.6
	SAC Repl Cartridge S/S 2400 mm (Dual)	CART2-96/2400-S/S	78587	17.8
	SAC Repl Cartridge S/S 3000 mm (Dual)	CART2-120/3000-S/S	78588	22.6
3	S/S V-Tip* (for vulcanised belts only)	RVT6-S/S	76205	0.4
4	PowerFlex™ Cushion S/S*	SPFC-S/S	79201	0.9
5	P/R Adjusting Bracket S/S	PAB-S/S	75515	0.4
6a	Cradle Clamp Block RH S/S	CRDLBLK-RH-S/S	A2825	1.2
6b	Cradle Clamp Block LH S/S	CRDLBLK-LH-S/S	A2826	1.2
7a	Mounting Bracket Kit RH S/S	PMBR-S/S	75521	3.8
7b	Mounting Bracket Kit LH S/S	PMBL-S/S	75518	3.8
8	SAC Removal Knuckle	SACRKN	77882	1.5
9	SAC Removal Handle S/S	SACRH-S/S	78397	1.4
10	SAC Handle Lock Plate S/S	SACRHL-S/S	78398	0.8
11	Knuckle Retainer Pin S/S	SACKRP-S/S	78399	0.1
-	SAC Removal Kit S/S (includes 1 ea. items 8,9,10,11)	SACRKT-S/S	78401	4.1
12	SAC Cartridge Tip Alignment Tool (Dual)	SAC2-TIP-TL	77866	1.1
-	Cradle Clamp Stainless Steel Heavy-Duty Mounting Kit (incl. 2 ea. item 5; incl. 1 ea. items 6a, 6b, 7a, 7b)	CRHMK-S/S	62095	10.8

Stock items (non-shaded) refer to (*) for specific lead time, if not specified, standard lead time applies.

Non-stock items (shaded) please contact Flexco for dispatch options and lead times.

Specifications & Guidelines

MHS SAC BT HD® Secondary Cleaner with Service Advantage Cartridge™ & Bolt Tensioner

Pole Length Specifications*

VERSION	CLEANER SIZE mm	BLADE WIDTH mm	POLE LENGTH mm	MAXIMUM CONVEYOR SPAN mm
Single	600	600	1950	1650
	750	750	2100	1800
	900	900	2250	1950
	1050	1050	2400	2100
	1200	1200	2550	2250
	1350	1350	2700	2400
	1500	1500	2850	2550
Dual	1800	1800	3150	2850
	1500	1500	3000	2700
	1800	1800	3300	3000
	2100	2100	3600	3300
	2400	2400	3900	3600
	3000	3000	4500	4200

*For special extra long pole length requirements a Pole Extender Kit (#76024) is available that provides 750 mm of extended pole length.
Pole Diameter - 73 mm

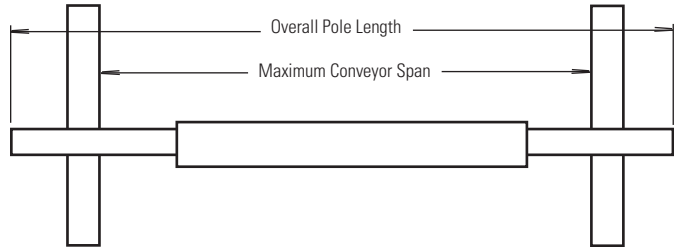

Clearance Guidelines for Installation

VERSION	HORIZONTAL CLEARANCE REQUIRED mm	VERTICAL CLEARANCE REQUIRED mm
Single	114	279
Dual	114	318

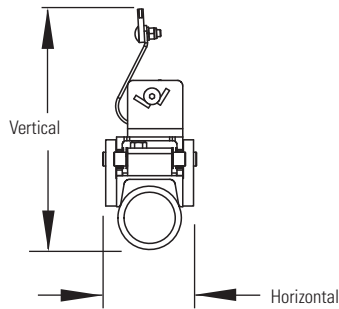

Specifications:

- Maximum Belt Speed5M/sec
- Temperature Rating-35°C to 82°C
- Usable Blade Wear Length.....9 mm
- Blade MaterialsC-Tip: Impact Resistant Tungsten Carbide (works with mechanical fasteners)
V-Tip: Long Life Tungsten Carbide (for vulcanised belts only)
- Available for Belt Widths600 to 3000 mm. Other sizes available upon request.

U.S. Patent Pending

Product Ordering Information

Spring Covers and Tensioner Lock

Spring Covers

ORDERING NUMBER	ITEM CODE	WT. KG.
SPG-CVR-A	77387	0.14
SPG-CVR-B	77388	0.14
SPG-CVR-C	77389	0.14
SPG-CVR-D	77390	0.18
SPG-CVR-E	77391	0.18
SPG-CVR-F	77392	0.14
SPG-CVR-G	77393	0.14
SPG-CVR-H	77741	0.14

Includes 1 spring cover

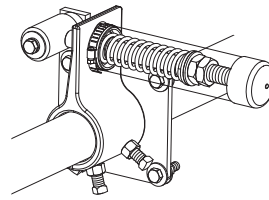
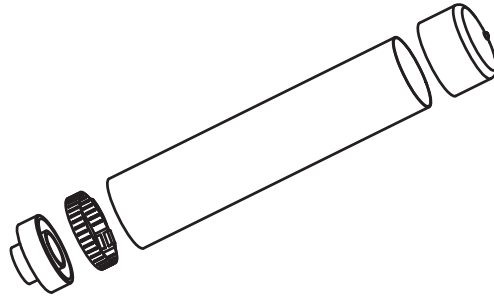

Spring cover on Primary Cleaner tensioner

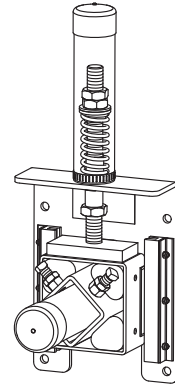

Spring cover on Secondary cleaner tensioner

Tensioner Lock

Designed to prevent tampering or unauthorized retensioning of the cleaner.

ORDERING NUMBER	ITEM CODE	WT. KG.
TEN-LOCK-KIT	77443	0.18

*For MSP, MMP, MHP, MHCP, H-Type® Primary Cleaners and MSS, MHS, MDWS Secondary Cleaners

Includes 1 tensioner lock

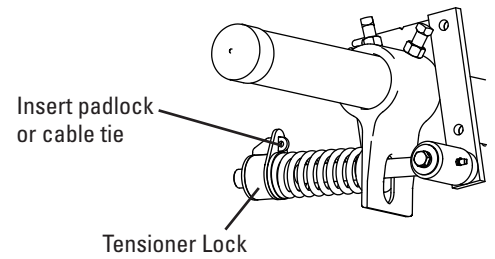
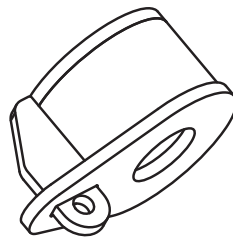

Tensioner Lock

(Primary Cleaner tensioner shown)

Patent pending

Stock items (non-shaded) refer to (*) for specific lead time, if not specified, standard lead time applies.

Non-stock items (shaded) please contact Flexco for dispatch options and lead times.

Product Ordering Information

U-Type® Secondary Cleaner with USTensioner



U-Type® with V-Blade (Tungsten Carbide)* and USTensioner, Mild Steel

CLEANER COMPLETE				REPLACEMENT V-BLADE		
BELT WIDTH mm	ORDERING NUMBER	ITEM CODE	WT. KG.	ORDERING NUMBER	ITEM CODE	WT. KG.
450	UTV450	77297	38.4	URVB18/450	76736	2.3
600	UTV600	77298	41.3	URVB24/600	76737	3.1
750	UTV750	77299	43.9	URVB30/750	76738	3.8
900	UTV900	77300	46.6	URVB36/900	76739	4.6
1050	UTV1050	77301	49.1	URVB42/1050	76740	5.3
1200	UTV1200	77302	51.9	URVB48/1200	76741	5.7
1350	UTV1350	77303	54.3	URVB54/1350	76742	6.8
1400	UTV1400	77304	55.1	URVB56/1400	77314	7.1
1500	UTV1500	77305	57.0	URVB60/1500	76743	7.6
1600	UTV1600	77306	59.0	URVB64/1600	77315	8.1
1800	UTV1800	77307	71.6	URVB72/1800	76744	9.2
2000	UTV2000	77308	75.3	URVB80/2000	77320	10.2
2100	UTV2100	77309	78.4	URVB84/2100	76745	10.7
2200	UTV2200	77310	81.7	URVB88/2200	77316	11.2
2400	UTV2400	77411	84.6	URVB94/2400	77421	12.0
2500	UTV2500	77412	87.1	URVB98/2500	77422	12.5

*NOTE: V-Blades (Tungsten Carbide) can be used on vulcanised belts and mechanically spliced belts ONLY IF the splice is skived (recessed into the belt's cover) (on solid plate splices the bolts must be ground).
CAUTION: The V-Blade CANNOT be used on belts with mechanical rip repair fasteners.

U-Type® with V-Blade (Tungsten Carbide)* and USTensioner, Stainless Steel

CLEANER COMPLETE				REPLACEMENT V-BLADE		
BELT WIDTH mm	ORDERING NUMBER	ITEM CODE	WT. KG.	ORDERING NUMBER	ITEM CODE	WT. KG.
450	UTV450-S/S	82707	17.0	URVB18/450	76736	2.3
600	UTV600-S/S	82708	18.2	URVB24/600	76737	3.1
750	UTV750-S/S	82709	19.6	URVB30/750	76738	3.8
900	UTV900-S/S	82710	21.7	URVB36/900	76739	4.6
1050	UTV1050-S/S	82711	23.1	URVB42/1050	76740	5.3
1200	UTV1200-S/S	82712	26.0	URVB48/1200	76741	5.7
1350	UTV1350-S/S	82713	27.7	URVB54/1350	76742	6.8
1400	UTV1400-S/S	82714	28.7	URVB56/1400	77314	7.1
1500	UTV1500-S/S	82715	31.0	URVB60/1500	76743	7.6
1600	UTV1600-S/S	82716	32.9	URVB64/1600	77315	8.1
1800	UTV1800-S/S	82717	36.4	URVB72/1800	76744	9.2
2000	UTV2000-S/S	82718	39.0	URVB80/2000	77320	10.2
2100	UTV2100-S/S	82719	41.7	URVB84/2100	76745	10.7
2200	UTV2200-S/S	82720	44.4	URVB88/2200	77316	11.2
2400	UTV2400-S/S	82721	47.1	URVB94/2400	77421	12.0
2500	UTV2500-S/S	82722	49.8	URVB98/2500	77422	12.5

*NOTE: V-Blades (Tungsten Carbide) can be used on vulcanised belts and mechanically spliced belts ONLY IF the splice is skived (recessed into the belt's cover) (on solid plate splices the bolts must be ground).
CAUTION: The V-Blade CANNOT be used on belts with mechanical rip repair fasteners.

Stock items (non-shaded) refer to (*) for specific lead time, if not specified, standard lead time applies.
 Non-stock items (shaded) please contact Flexco for dispatch options and lead times.

Product Ordering Information

U-Type® Secondary Cleaner with J-Bolt Tensioner

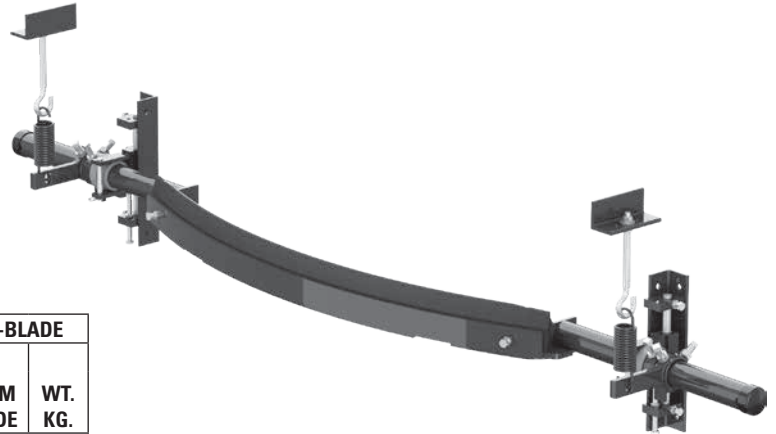

U-Type® with V-Blade (Tungsten Carbide)* and J-Bolt Tensioner, Mild Steel

CLEANER COMPLETE				REPLACEMENT V-BLADE		
BELT WIDTH mm	ORDERING NUMBER	ITEM CODE	WT. KG.	ORDERING NUMBER	ITEM CODE	WT. KG.
450	UTV450-J	77283	37.3	URVB18/450	76736	2.3
600	UTV600-J	77284	40.0	URVB24/600	76737	3.1
750	UTV750-J	77285	43.2	URVB30/750	76738	3.8
900	UTV900-J	77286	47.7	URVB36/900	76739	4.6
1050	UTV1050-J	77287	50.9	URVB42/1050	76740	5.3
1200	UTV1200-J	77288	57.3	URVB48/1200	76741	5.7
1350	UTV1350-J	77289	60.9	URVB54/1350	76742	6.8
1400	UTV1400-J	77290	63.2	URVB56/1400	77314	7.1
1500	UTV1500-J	77291	68.2	URVB60/1500	76743	7.6
1600	UTV1600-J	77292	72.3	URVB64/1600	77315	8.1
1800	UTV1800-J	77293	80.0	URVB72/1800	76744	9.2
2000	UTV2000-J	77294	85.9	URVB80/2000	77320	10.2
2100	UTV2100-J	77295	91.8	URVB84/2100	76745	10.7
2200	UTV2200-J	77296	97.7	URVB88/2200	77316	11.2
2400	UTV2400-J	77413	103.6	URVB94/2400	77421	12.0
2500	UTV2500-J	77414	109.6	URVB98/2500	77422	12.5

*NOTE: V-Blades (Tungsten Carbide) can be used on vulcanised belts and mechanically spliced belts ONLY IF the splice is skived (recessed into the belt's cover) (on solid plate splices the bolts must be ground).

CAUTION: The V-Blade CANNOT be used on belts with mechanical rip repair fasteners.

U-Type® with V-Blade (Tungsten Carbide)* and J-Bolt Tensioner, Stainless Steel

CLEANER COMPLETE				REPLACEMENT V-BLADE		
BELT WIDTH MM	ORDERING NUMBER	ITEM CODE	WT. KG.	ORDERING NUMBER	ITEM CODE	WT. KG.
450	UTV450J-S/S	77259	37.3	URVB18/450	76736	2.3
600	UTV600J-S/S	77260	40.0	URVB24/600	76737	3.1
750	UTV750J-S/S	77261	43.2	URVB30/750	76738	3.8
900	UTV900J-S/S	77262	47.7	URVB36/900	76739	4.6
1050	UTV1050J-S/S	77263	50.9	URVB42/1050	76740	5.3
1200	UTV1200J-S/S	77264	57.3	URVB48/1200	76741	5.7
1350	UTV1350J-S/S	77265	60.9	URVB54/1350	76742	6.8
1400	UTV1400J-S/S	77266	63.2	URVB56/1400	77314	7.1
1500	UTV1500J-S/S	77267	68.2	URVB60/1500	76743	7.6
1600	UTV1600J-S/S	77268	72.3	URVB64/1600	77315	8.1
1800	UTV1800J-S/S	77269	80.0	URVB72/1800	76744	9.2
2000	UTV2000J-S/S	77270	85.9	URVB80/2000	77320	10.2
2100	UTV2100J-S/S	77271	91.8	URVB84/2100	76745	10.7
2200	UTV2200J-S/S	77272	97.7	URVB88/2200	77316	11.2
2400	UTV2400J-S/S	77417	103.6	URVB94/2400	77421	12.0
2500	UTV2500J-S/S	77418	109.6	URVB98/2500	77422	12.5

*NOTE: V-Blades (Tungsten Carbide) can be used on vulcanised belts and mechanically spliced belts ONLY IF the splice is skived (recessed into the belt's cover) (on solid plate splices the bolts must be ground).

CAUTION: The V-Blade CANNOT be used on belts with mechanical rip repair fasteners.

Stainless Steel U-Type with C or F blade available by special order

Stock items (non-shaded) refer to (*) for specific lead time, if not specified, standard lead time applies.

Non-stock items (shaded) please contact Flexco for dispatch options and lead times.

Replacement Parts List

U-Type® Secondary Cleaner with UST Tensioner or J-Bolt Tensioner

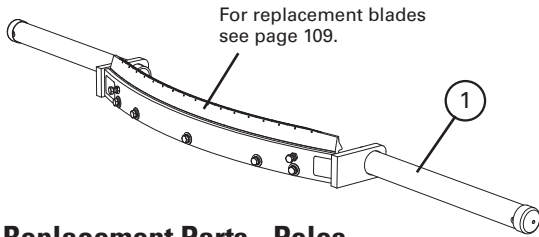

Replacement Parts - Poles

REF	DESCRIPTION	ORDERING NUMBER	ITEM CODE	WT. KG.
1	450mm Pole	USP18/450	82689	18.6
	600mm Pole	USP24/600	82690	20.1
	750mm Pole	USP30/750	82691	21.6
	900mm Pole	USP36/900	82692	23.2
	1050mm Pole	USP42/1050	82693	24.8
	1200mm Pole	USP48/1200	82694	26.3
	1350mm Pole	USP54/1350	82695	27.9
	1400mm Pole	USP56/1400	82696	28.4
	1500mm Pole	USP60/1500	82697	29.5
	1600mm Pole	USP64/1600	82698	30.5
	1800mm Pole	USP72/1800	82699	32.6
	2000mm Pole	USP80/2000	82700	34.6
	2100mm Pole	USP84/2100	82701	35.7
	2200mm Pole	USP88/2200	82702	36.7
	2400mm Pole	USP94/2400	82703	38.3
2500mm Pole	USP98/2500	82704	39.4	

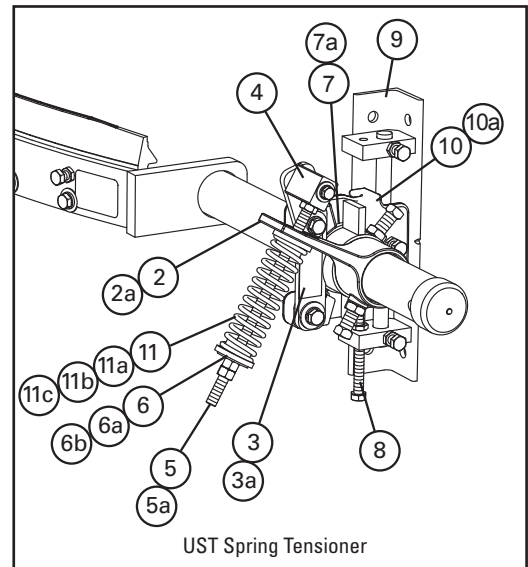

UST Spring Tensioner

Replacement Parts - UST Tensioner

REF	DESCRIPTION	ORDERING NUMBER	ITEM CODE	WT. KG.
2	Torque Arm Kit (1 ea.)	ESTAK	76406	1.6
2A	Torque Arm Kit HD (1 ea.)	C-PSTA	81045	5.2
3	Pivot Shaft Bracket Kit (1 ea.)	MUPSBK	82896	0.8
3A	Pivot Shaft Bracket Kit HD (1 ea.)	QMTPSBK-CN	82182	2.0
4	Pivot Block Kit (1 ea.)	MESPBL	87895	0.5
5	Pivot Rod Kit (1 ea.)	MESPKR	81896	0.5
5A	Pivot Rod Kit HD (1 ea.)	PTPK-MT	82343	2.0
6	EST Bush Kit P&S MET	MESBK-PS	82364	0.05
6A	QMT Bush Kit W&S MET	QMTBK-WS-MT	82175	0.05
6B	QMT Bush Kit G MET	QMTBK-GCN	82174	0.05
7	Standard Pole Bearing (1 ea.)	USPB2	79206	0.05
7A	HD Pole Bearing (1 ea.)	UHPB2	79207	0.1
8	Adjusting Bolt Kit (1 ea. incl. lock nut)	ABU	76788	0.1
9	Mounting Bracket Kit (1 ea. incl. L & R)	UMBK-M	82890	4.4
10	Slide Plate Kit (1 ea.)	USPK	76790	2.1
10A	HD Slide Plate Kit (1 ea.)	UHSPK-M	82887	2.4
11	Tension Spring Purple (1 ea.)	QMTS-P	75845	0.3
11A	Tension Spring Silver (1 ea.)	ESS-S	76412	0.5
11B	Tension Spring White (1 ea.)	PSTS-W	75898	0.8
11C	Tension Spring Gold (1 ea.)	QMT-G	76484	0.8
-	UST Spring Tensioner Mounting Kit* - Purple (Incl. 1 ea. Items 2, 3, 4, 5, 6, 8, 9, 10 & 11)	UST-P-MT	82897	9.5
-	UST Spring Tensioner Mounting Kit* - Silver (Incl. 1 ea. Items 2A, 4, 5A, 6A, 8, 9, 10A & 11A)	UST-S-MT	82898	13.1
-	Heavy-Duty UST Spring Tensioner* - White (Incl. 1 ea. Items 2A, 4, 5A, 6A, 8, 9, 10A & 11B)	UST-W-MT	82899	16.7
-	Heavy-Duty UST Spring Tensioner* - Gold (Incl. 1 ea. Items 2A, 4, 5A, 6A, 8, 9, 10A & 11C)	UST-G-MT	82900	16.7

*Hardware included

Note: For belt widths equal to and larger than 1600mm use heavy-duty components.

Stock items (non-shaded) refer to (*) for specific lead time, if not specified, standard lead time applies.

Non-stock items (shaded) please contact Flexco for dispatch options and lead times.

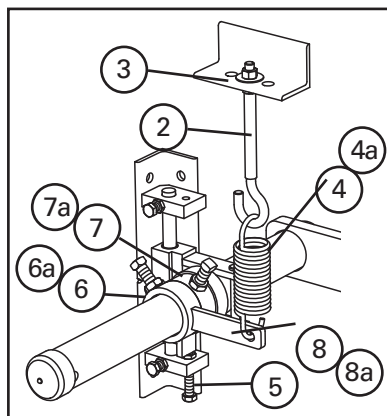

For use in changing UST Spring Tensioner to a J-Bolt Tensioner

Replacement Parts - J-bolt Tensioner

REF	DESCRIPTION	ORDERING NUMBER	ITEM CODE	WT. KG.
2	J-Bolt Kit* (incl. locknut and washer)	STJK-S/S	74417	0.3
3	J-Bolt Mount (1 ea.)	STJM	74775	1.4
4	450-1500mm Tension Spring (1 ea.)	STTS	74419	0.5
4a	1600 mm+ Tension Spring (1 ea.)	HDTTS	74502	0.7
5	Adjusting Bolt Kit (incl. locknut)	ABU	76788	0.5
6	450-1500 mm UHMW Bearing (1 ea.)	USPB	76786	0.5
6a	1600 mm+ UHMW Bearing (1 ea.)	UHPB	79206	0.5
7	450-1500 mm Stop Collar* (1 ea.)	SCU60	82812	0.9
7a	1600 mm+ Stop Collar* (1 ea.)	SCUHD	82813	0.9
8	450-1500 mm Adjusting Arm* (1 ea.)	HARK	73069	0.9
8a	1600mm+ Adjusting Arm* (1 ea.)	HDARK	77329	0.9
-	450-1500 mm Mounting Kit* (incl. 2 of items 2, 3, 4, 5, 6, 7, 8, 9 & incl. 1 of Item 5)	MMKU	77324	18.2
-	1600 mm+ Mounting Kit* (incl. 2 of items 2, 3, 4a, 6, 7a, 8a, 9a & incl. 1 of item 5)	MMKUHD	77327	19.6

*Hardware included

Replacement Parts List

Stainless Steel U-Type[®] Secondary Cleaner with UST Tensioner or J-Bolt Tensioner

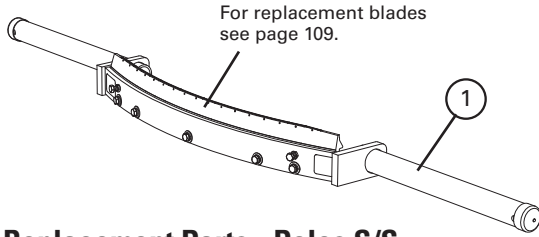

Replacement Parts - Poles S/S

REF	DESCRIPTION	ORDERING NUMBER	ITEM CODE	WT. KG.
1	450mm Pole	USP18/450-S/S	77339	18.6
	600mm Pole	USP24/600-S/S	77340	20.1
	750mm Pole	USP30/750-S/S	77341	21.6
	900mm Pole	USP36/900-S/S	77342	23.2
	1050mm Pole	USP42/1050-S/S	77343	24.8
	1200mm Pole	USP48/1200-S/S	77344	26.3
	1350mm Pole	USP54/1350-S/S	77345	27.9
	1400mm Pole	USP56/1400-S/S	77346	28.4
	1500mm Pole	USP60/1500-S/S	77347	29.5
	1600mm Pole	USP64/1600-S/S	77348	30.5
	1800mm Pole	USP72/1800-S/S	77349	32.6
	2000mm Pole	USP80/2000-S/S	77350	34.6
	2100mm Pole	USP84/2100-S/S	77351	35.7
	2200mm Pole	USP88/2200-S/S	77352	36.7
	2400mm Pole	USP94/2400-S/S	77419	38.3
2500mm Pole	USP98/2500-S/S	77418	39.4	

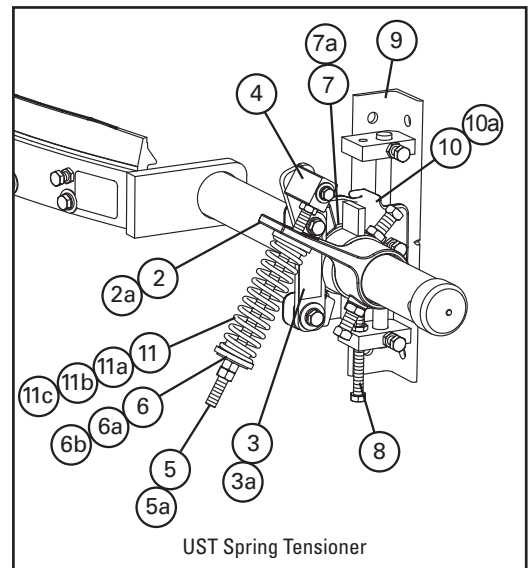

UST Spring Tensioner

Replacement Parts - UST Tensioner S/S

REF	DESCRIPTION	ORDERING NUMBER	ITEM CODE	WT. KG.
2	Torque Arm Kit (1 ea.)	ESTAK-SS	78849	1.6
2A	Torque Arm Kit HD (1 ea.)	MPSTA-S/S	82289	5.2
3	Pivot Shaft Bracket Kit (1 ea.)	MUPSBK-SS	82893	0.8
3A	Pivot Shaft Bracket Kit HD (1 ea.)	MQMTSBK-SS	82895	2.0
4	Pivot Block Kit (1 ea.)	MESPBL-SS	82892	0.5
5	Pivot Rod Kit (1 ea.)	MESPKR-SS	82894	0.5
5A	Pivot Rod Kit HD (1 ea.)	PTPK-MT-S/S	82342	2.0
6	EST Bush Kit P&S MET	MESBK-PS	82364	0.05
6A	QMT Bush Kit W&S MET	QMTBK-WS-MT	82175	0.05
6B	QMT Bush Kit G MET	QMTBK-GCN	82174	0.05
7	Standard Pole Bearing (1 ea.)	USPB2	79206	0.05
7A	HD Pole Bearing (1 ea.)	UHPB2	79207	0.1
8	Adjusting Bolt Kit (1 ea. incl. lock nut)	ABU	76788	0.1
9	Mounting Bracket Kit (1 ea. incl. L & R)	UMBK-SS-M	82891	4.4
10	Slide Plate Kit (1 ea.)	USPK-SS-M	82888	2.1
10A	HD Slide Plate Kit (1 ea.)	UHSPK-SS-M	82889	2.4
11	Tension Spring Purple (1 ea.)	QMTS-P-SS	77450	0.3
11A	Tension Spring Silver (1 ea.)	ESS-S-S/S	79288	0.5
11B	Tension Spring White (1 ea.)	QMTS-W-SS	77451	0.8
11C	Tension Spring Gold (1 ea.)	QMTS-G-SS	77452	0.8
-	UST Spring Tensioner Mounting Kit* - Purple (Incl. 1 ea. Items 2, 3, 4, 5, 6, 8, 9, 10 & 11)	UST-P-MT-SS	82901	9.5
-	UST Spring Tensioner Mounting Kit* - Silver (Incl. 1 ea. Items 2A, 4, 5A, 6A, 8, 9, 10A & 11A)	UST-S-MT-SS	82902	13.1
-	Heavy-Duty UST Spring Tensioner* - White (Incl. 1 ea. Items 2A, 4, 5A, 6A, 8, 9, 10A & 11B)	UST-W-MT-SS	82903	16.7
-	Heavy-Duty UST Spring Tensioner* - Gold (Incl. 1 ea. Items 2A, 4, 5A, 6A, 8, 9, 10A & 11C)	UST-G-MT-SS	82904	16.7

*Hardware included

Note: For belt widths equal to and larger than 1600mm use heavy-duty components.

Stock items (non-shaded) refer to (*) for specific lead time, if not specified, standard lead time applies.

Non-stock items (shaded) please contact Flexco for dispatch options and lead times.

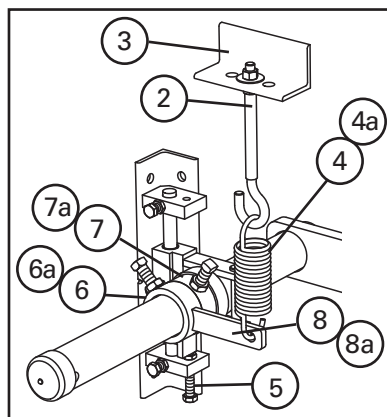

For use in changing UST Spring Tensioner to a J-Bolt Tensioner

Replacement Parts - J-bolt Tensioner S/S

REF	DESCRIPTION	ORDERING NUMBER	ITEM CODE	WT. KG.
2	J-Bolt Kit* (incl. locknut and washer)	STJK-S/S	74417	0.3
3	J-Bolt Mount (1 ea.)	STJM-S/S	77332	1.4
4	450-1500mm Tension Spring (1 ea.)	STTS-S/S	75585	0.5
4a	1600 mm+ Tension Spring (1 ea.)	HDTS-S/S	75586	0.7
5	Adjusting Bolt Kit (incl. locknut)	ABU	76788	0.5
6	450-1500 mm UHMW Bearing (1 ea.)	USPB	79206	0.5
6a	1600 mm+ UHMW Bearing (1 ea.)	UHPB	76787	0.5
7	450-1500 mm Stop Collar* (1 ea.)	SCU60-S/S	82810	0.9
7a	1600 mm+ Stop Collar* (1 ea.)	SCUHD-S/S	82811	0.9
8	450-1500 mm Adjusting Arm* (1 ea.)	HARK-S/S	77364	0.9
8a	1600mm+ Adjusting Arm* (1 ea.)	HDARK-S/S	77331	0.9
-	450-1500 mm Mounting Kit* (incl. 2 of items 2, 3, 4, 5, 6, 7, 8, 9 & incl. 1 of Item 5)	MMKU-SS	77357	18.2
-	1600 mm+ Mounting Kit* (incl. 2 of items 2, 3, 4a, 6, 7a, 8a, 9a & incl 1 of item 5)	MMKUHD-SS	77358	19.6

*Hardware included

Replacement Parts List

U-Type® V-Blades (Tungsten Carbide)*

BELT WIDTH mm	ORDERING NUMBER	ITEM CODE	WT. KG.
450	URVB18/450	76736	2.3
600	URVB24/600	76737	3.1
750	URVB30/750	76738	3.8
900	URVB36/900	76739	4.6
1050	URVB42/1050	76740	5.3
1200	URVB48/1200	76741	6.1
1350	URVB54/1350	76742	6.8
1400	URVB56/1400	77314	7.1
1500	URVB60/1500	76743	7.6
1600	URVB64/1600	77315	8.1
1800	URVB72/1800	76744	9.2
2000	URVB80/2000	77320	10.2
2100	URVB84/2100	76745	10.7
2200	URVB88/2200	77316	11.2
2400	URVB94/2400	77421	12.0
2500	URVB98/2500	77422	12.5

*NOTE: V-Blades (Tungsten Carbide) can be used on vulcanised belts. CAUTION: The V-Blade CANNOT be used on belts with mechanical rip repair fasteners. Use the F-Blade. Replacement blades also available in FRAS. Contact Flexco® for more information.

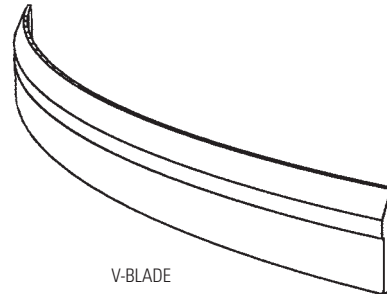

V-BLADE

U-Type® C-Blades (Impact-Resistant Tungsten Carbide)*

BELT WIDTH mm	ORDERING NUMBER	ITEM CODE	WT. KG.
450	URCB18/450	76748	2.3
600	URCB24/600	76749	3.1
750	URCB30/750	76750	3.8
900	URCB36/900	76751	4.6
1050	URCB42/1050	76752	5.3
1200	URCB48/1200	76753	6.1
1350	URCB54/1350	76754	6.8
1400	URCB56/1400	77317	7.1
1500	URCB60/1500	76755	7.6
1600	URCB64/1600	77318	8.1
1800	URCB72/1800	76756	9.2
2000	URCB80/2000	77321	10.2
2100	URCB84/2100	76757	10.7
2200	URCB88/2200	76319	11.2
2400	URCB94/2400	77448	12.0
2500	URCB98/2500	77449	12.5

*NOTE: C-Blades can be used on Flexco Solid Plate, mechanically fastened and vulcanised belts. Replacement blades also available in FRAS. Contact Flexco for more information.

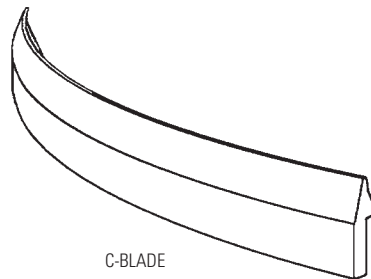

C-BLADE

U-Type® F-Blades (Purple Urethane)*

BELT WIDTH mm	ORDERING NUMBER	ITEM CODE	WT. KG.
450	UFB18	74448	1.4
600	UFB24	74449	1.8
750	UFB30	74450	2.3
900	UFB36	74451	2.7
1050	UFB42	74452	3.2
1200	UFB48	74453	3.6
1350	UFB54	74454	4.1
1500	UFB60	74455	4.6
1800	UFB72	74456	5.5
2100	UFB84	74460	6.4

*NOTE: F-Blades (Urethane) can be used on mechanically fastened belts and vulcanised belts.

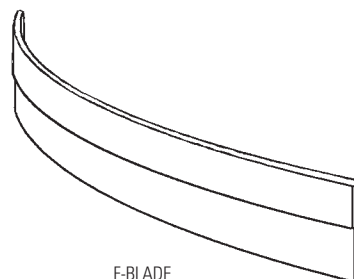

F-BLADE

Stock items (non-shaded) refer to (*) for specific lead time, if not specified, standard lead time applies.
Non-stock items (shaded) please contact Flexco for dispatch options and lead times.

Specifications & Guidelines

Pole Length Specifications

CLEANER SIZE mm	POLE LENGTH mm	MAXIMUM CONVEYOR SPAN mm
450	1375	1125
600	1575	1325
750	1825	1575
900	1975	1925
1050	2125	1875
1200	2375	2125
1350	2525	2275
1500	2650	2400
1800	2950	2700

Pole Diameter - 450-1500 mm cleaners: 60 mm
Pole Diameter - 1600 mm+ cleaners: 75 mm

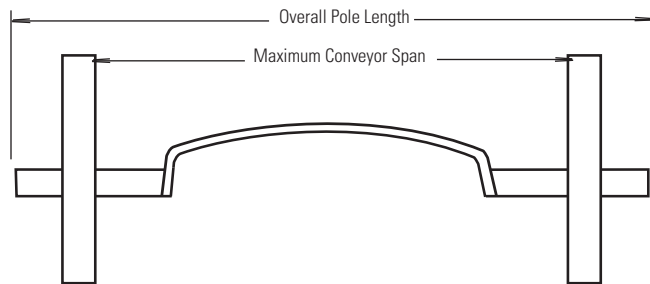

Clearance Guidelines For Installation

BELT WIDTH/ CLEANER SIZE mm	CLEARANCE REQUIRED mm
450	140
600	166
750	191
900	171
1050	217
1200	242
1350	242
1500	242
1800	261
2100	261

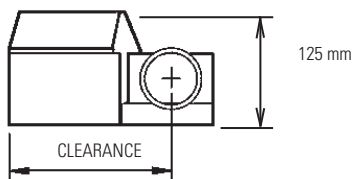

Spring Length Chart

(For Cleaners with UST Tensioners)

BLADE WIDTH mm	PURPLE SPRING mm	SILVER SPRING mm
450	160	N/A
600	156	N/A
750	152	N/A
900	147	N/A
1050	142	N/A
1200	133	N/A
1350	127	N/A
1400	125	N/A
1500	125	N/A
1600	N/A	142
1800	N/A	142
2000	N/A	138
2100	N/A	136
2200	N/A	136
2400	N/A	133
2500	N/A	132

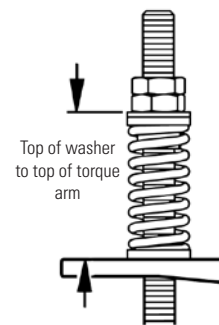

Spring Tensioner Guidelines

(For Cleaners with J-Bolt Tensioners)

- Spring gap = .7 mm minimum
- Gauge provided

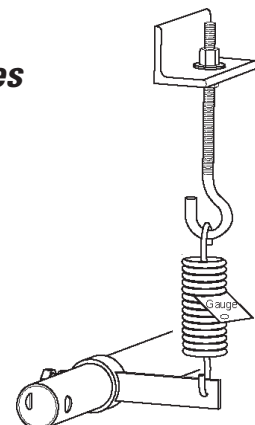

Specifications:

- Maximum Belt SpeedContact Flexco®
- Temperature Rating-35°C to 82°C
- Usable Blade Wear Length.....V-Blade and C-Blade - 9 mm; F-Blade - 44 mm
- Available for Belt Widths450 to 2500 mm.
Other sizes available upon request

Product Ordering Information

Motorised Brush Cleaner



Motorised Brush Cleaner

Motorized Brush Cleaner

BELT WIDTH		ORDERING NUMBER	ITEM CODE	WT. KG.
mm	in.			
450	18	MBC-18	79494	62.1
600	24	MBC-24	79495	66.6
750	30	MBC-30	79496	68.3
900	36	MBC-36	79497	71.1
1050	42	MBC-42	79498	73.9
1200	48	MBC-48	79499	81.4
1350	54	MBC-54	79500	84.5
1500	60	MBC-60	79501	87.3
1800	72	MBC-72	79502	93.2
2100	84	MBC-84	79503	98.9

Replacement Brushes

BELT WIDTH		ORDERING NUMBER	ITEM CODE	WT. LBS.
mm	in.			
450	18	MBRD-18	79514	9.6
600	24	MBRD-24	79515	13.5
750	30	MBRD-30	79516	17.1
900	36	MBRD-36	79517	20.5
1050	42	MBRD-42	79518	23.7
1200	48	MBRD-48	79519	26.8
1350	54	MBRD-54	79520	30.7
1500	60	MBRD-60	79521	33.9
1800	72	MBRD-72	79522	41.0
2100	84	MBRD-84	79523	47.5

Optional Mounting Brackets (Pair)

ORDERING NUMBER	ITEM CODE	WT. LBS.
MBCDBK	79536	28.9

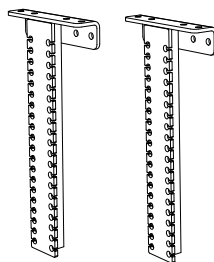

Product Notes:

- Spins opposite the belt direction for optimal cleaning.
- Uniquely patterned bristles aid in reducing material buildup and clogging.
- Adjustable tensioners allow easy brush-to-belt adjustment as the bristles wear.
- Works on mechanically spliced or vulcanised belts.

 Stock items (non-shaded) refer to (*) for specific lead time, if not specified, standard lead time applies.

 Non-stock items (shaded) please contact Flexco for dispatch options and lead times.

Specifications & Guidelines

Motorised Brush Cleaner

Specifications

Belt Speed	3.5M/sec (Up to 700 fpm)
Vertical and Horizontal Clearance	305mm (12")
Temperature Range	-30°C to 82°C (-20°F to 180°F)
Maximum Chevron or Cleat Height	13mm (1/2")
Bristle Length	83mm (3-1/4")
Overall Diameter	305mm (12")
Shaft Length	Belt Width plus 915mm (36")
Shaft Diameter	38mm (1-1/2")
Motor HP	1 HP cleaners 450-1050mm (1050mm)
	2 HP cleaners 1200-2100mm (48-84")
Motor voltage	230/400V

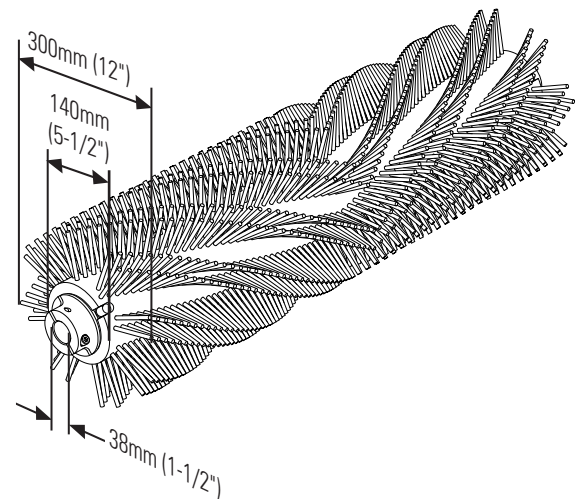
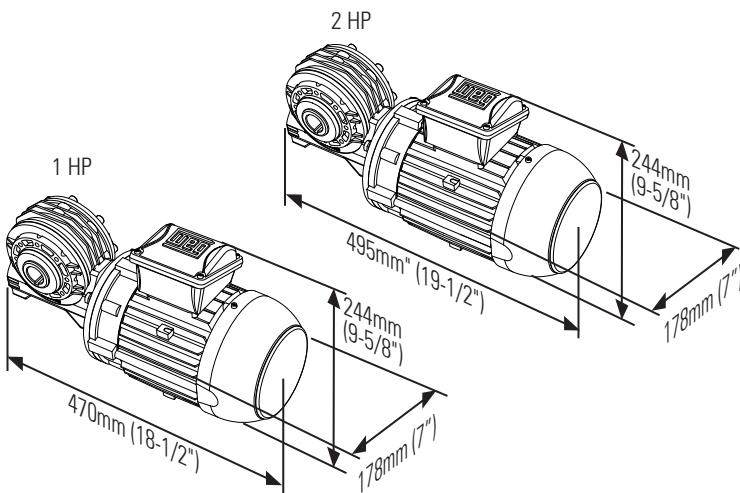
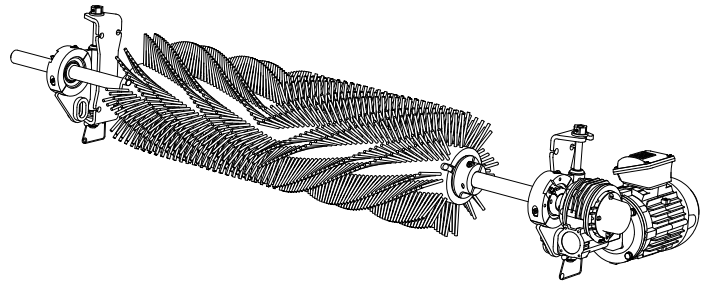

Replacement Parts List

Motorised Brush Cleaner

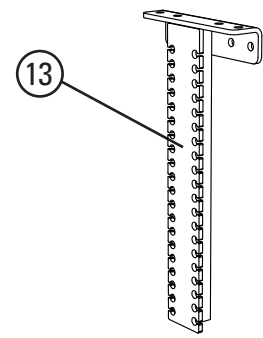
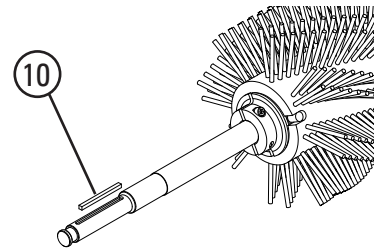
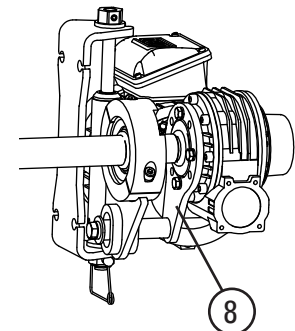
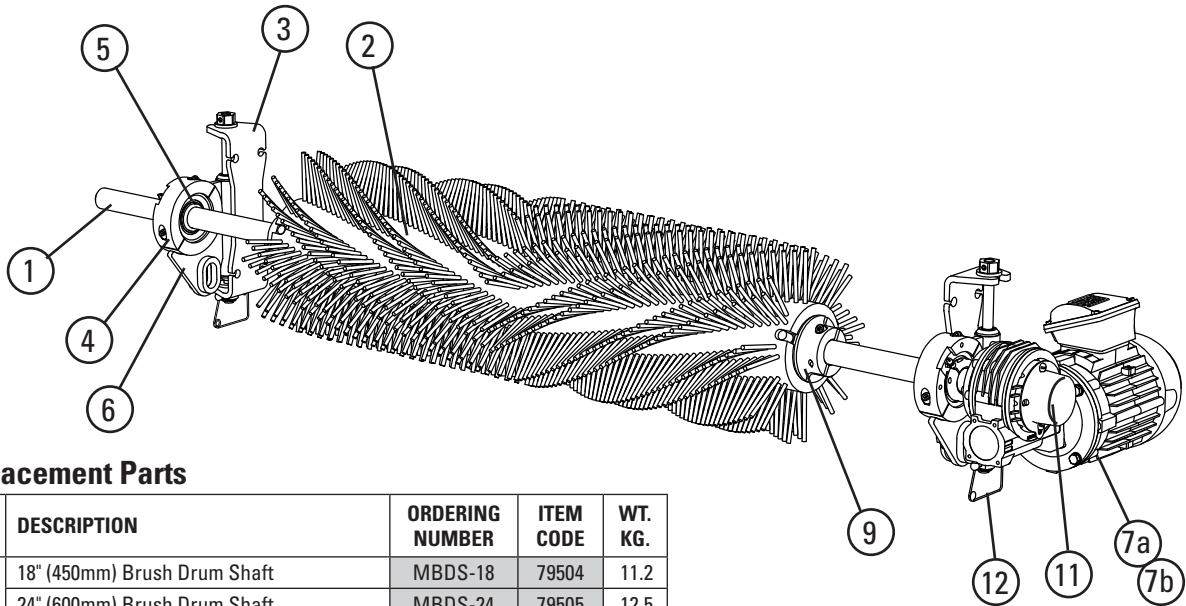

Replacement Parts

REF	DESCRIPTION	ORDERING NUMBER	ITEM CODE	WT. KG.
1	18" (450mm) Brush Drum Shaft	MBDS-18	79504	11.2
	24" (600mm) Brush Drum Shaft	MBDS-24	79505	12.5
	30" (750mm) Brush Drum Shaft	MBDS-30	79506	13.9
	36" (900mm) Brush Drum Shaft	MBDS-36	79507	15.3
	42" (1050mm) Brush Drum Shaft	MBDS-42	79508	16.6
	48" (1200mm) Brush Drum Shaft	MBDS-48	79509	18.0
	54" (1350mm) Brush Drum Shaft	MBDS-54	79510	19.3
	60" (1500mm) Brush Drum Shaft	MBDS-60	79511	20.7
	72" (1800mm) Brush Drum Shaft	MBDS-72	79512	23.4
84" (2100mm) Brush Drum Shaft	MBDS-84	79513	26.1	
2	18" (450mm) Replacement Brush Drum	MBRD-18	79514	4.4
	24" (600mm) Replacement Brush Drum	MBRD-24	79515	6.1
	30" (750mm) Replacement Brush Drum	MBRD-30	79516	7.8
	36" (900mm) Replacement Brush Drum	MBRD-36	79517	9.3
	42" (1050mm) Replacement Brush Drum	MBRD-42	79518	10.8
	48" (1200mm) Replacement Brush Drum	MBRD-48	79519	12.2
	54" (1350mm) Replacement Brush Drum	MBRD-54	79520	14.0
	60" (1500mm) Replacement Brush Drum	MBRD-60	79521	15.4
	72" (1800mm) Replacement Brush Drum	MBRD-72	79522	18.6
84" (2100mm) Replacement Brush Drum	MBRD-84	79523	21.6	
3	Brush Mounting Base* (1)	MBCM	79524	2.1
4	Brush Bearing Clamp* (1)	MBCBC	79525	0.9
5	Brush Cleaner Bearings (2)	MBCB	79526	3.3
6	Brush Bearing Mount* (1)	MBCBM	79528	4.4
7a	Gearmotor Assy, 1 HP for belts up to 42" (1050mm)	MBCM-1	79529	25.0
7b	Gearmotor Assy, 2 HP for belts 48" (1200mm) and up	MBCM-2	79530	29.5
8	Brush Cleaner Torque Arm* (1)	MBCTA	79531	1.1
9	Brush Locks* (2)	MBCBL	79532	4.3
10	Brush Motor Key Kit (1)	MBCMCK	79533	0.1
11	MBC Shaft End Cap* (1)	MBCCEC	79534	0.0
12	Tensioner Lock Pins (2)	STLP	79535	0.1
13	Brush Cleaner Drop Brackets* (2)	MBCDBK	79536	13.1
-	Brush Cleaner Adjusting Bracket (1) (incl. bearing and 1 ea. items 3,4,6,&12)	MBADB	79527	8.2

*Hardware Included

Stock items (non-shaded) refer to (*) for specific lead time, if not specified, standard lead time applies.

Non-stock items (shaded) please contact Flexco for dispatch options and lead times.

Product Ordering Information

Chevron Belt Cleaner

Chevron Belt Cleaner

BELT WIDTH		DRUM WIDTH		ORDERING NUMBER	ITEM CODE	WT. KG.
mm	in.	mm	in.			
450	18	450	18	CBC18	76668	34.9
600	24	600	24	CBC24	76669	40.0
750	30	750	30	CBC30	76670	45.0
900	36	900	36	CBC36	76671	50.1
1050	42	1050	42	CBC42	76672	55.1
1200	48	1200	48	CBC48	76673	60.2
1350	54	1350	54	CBC54	76674	65.2
1500	60	1500	60	CBC60	76675	70.3

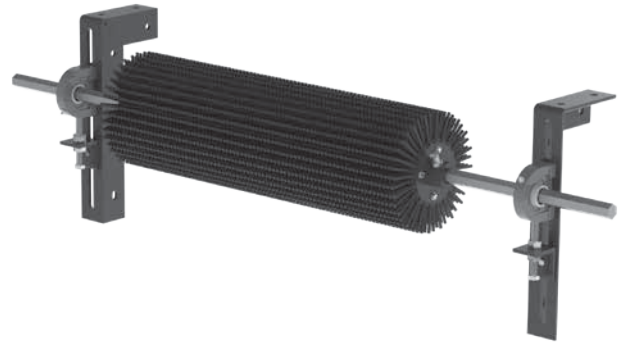

Replacement Parts

REF	DESCRIPTION	ORDERING NUMBER	ITEM CODE	WT. KG.
1	450 mm Drum Shaft	CDS18	76684	6.9
	600 mm Drum Shaft	CDS24	76685	7.7
	750 mm Drum Shaft	CDS30	76686	8.6
	900 mm Drum Shaft	CDS36	76687	9.5
	1050 mm Drum Shaft	CDS42	76688	10.3
	1200 mm Drum Shaft	CDS48	76689	11.2
	1350 mm Drum Shaft	CDS54	76690	12.0
	1500 mm Drum Shaft	CDS60	76691	12.9
2	Chevron Pillow Block*	CPB	76692	0.6
3	450 mm Replacement Drum w/Fingers*	CRDF18	90631	12.6
	600 mm Replacement Drum w/Fingers*	CRDF24	90632	16.8
	750 mm Replacement Drum w/Fingers*	CRDF30	90633	21.0
	900 mm Replacement Drum w/Fingers*	CRDF36	90634	25.2
	1050 mm Replacement Drum w/Fingers*	CRDF42	90635	29.4
	1200 mm Replacement Drum w/Fingers*	CRDF48	90636	33.6
	1350 mm Replacement Drum w/Fingers*	CRDF54	90637	37.8
	1500 mm Replacement Drum w/Fingers*	CRDF60	90638	42.0
4	75mm Replacement Finger Ring	CBC3R	90641	1.1
5	Mounting Bracket, Right	PMBR	75519	3.8
	Mounting Bracket, Left	PMBL	75516	3.8
6	Adjusting Bracket Kit* (1 ea.)	PAB	75513	0.9

*Hardware Included

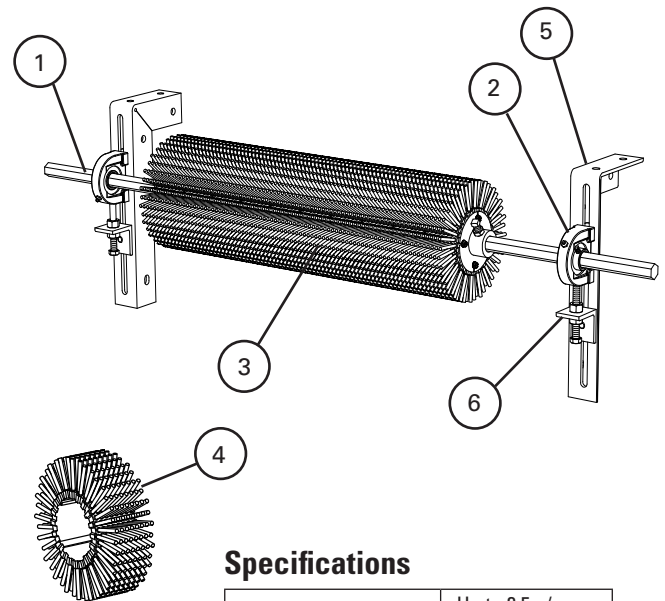

Specifications

Belt Speed	Up to 2.5m/s (500 fpm)
Vertical and Horizontal Clearance	250mm (10")
Temperature Range	-35°C to 82°C (-30°F to 180°F)
Maximum Chevron or Cleat Height	25mm (1")
Finger Length	50mm (2")
Rubber Durometer	45A
Overall Diameter	238mm (9-1/2")
Shaft Length	Belt Width plus 750mm (30")
Shaft	25mm (1") Hex
CEMA Cleaner Rating	Class 3

Product Notes:

- Free-rotating. Works only when the belt is running.
- Self-cleaning. Finger length, spacing and the rotary action allows carryback to fall free instead of clogging.
- Easy to install. Few parts and step-by-step instructions make the job simple.
- Long-wearing SBR rubber. Drum life ranges from 1 to 3 years depending upon the application conditions and the material being conveyed.
- Works on reversing belts.
- Finger rings can be replaced individually or all at once by replacing the drum.

Stock items (non-shaded) refer to (*) for specific lead time, if not specified, standard lead time applies.

Non-stock items (shaded) please contact Flexco for dispatch options and lead times.

Product Ordering Information

Wash Box

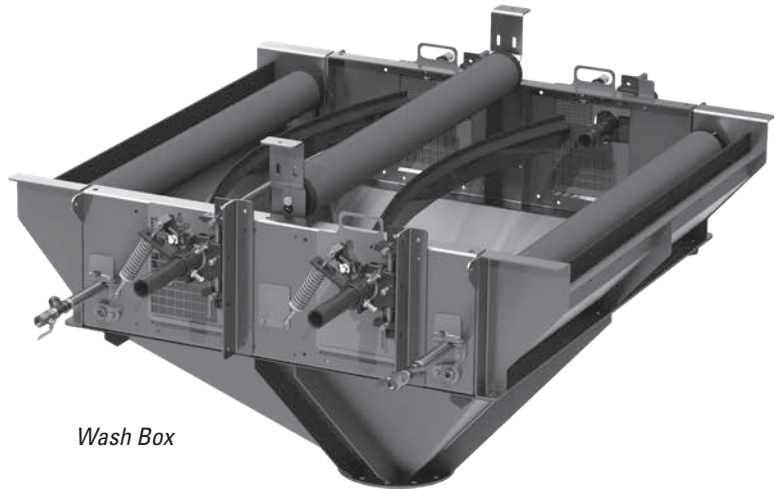

Wash Box

Wash Box

Belt Width	"A"	"B"	"C"	"D"	MASS	VOLUME
	Outside Conveyor Stringers (mm)	Mounting Hole Centres (mm)	Overall Width (mm)	Height to Outlet Flange (mm)	Excludes Cleaners & Rollers (kg)	Enclosed in Wash Box (m ³)
600	910	850	1,085	940	295	0.7
750	1,060	1,000	1,235	955	310	0.8
900	1,210	1,150	1,385	995	330	1.0
1,050	1,360	1,300	1,535	1,015	345	1.1
1,200	1,510	1,450	1,685	1,060	365	1.3
1,350	1,710	1,650	1,885	1,110	390	1.5
1,400	1,760	1,700	1,935	1,125	395	1.6
1,500	1,860	1,800	2,035	1,150	410	1.7
1,600	2,060	2,000	2,235	1,210	435	1.9
1,800	2,260	2,200	2,435	1,265	465	2.2
2,000	2,460	2,400	2,635	1,325	505	2.4

Product Notes:

- Please contact Flexco for pricing and lead time.
- The dimensions, mass and volumes shown here are nominal for a standard Flexco Wash Box and will be confirmed to suit each specific application.
- Each Stainless Steel Wash Box comes equipped with a combination of pressure rollers, spray bars and recovery system.
- The Wash Box is designed to accommodate any two secondary cleaners from the Flexco range, the belt cleaners are sold separately.
- Manufactured in Bundaberg, QLD, Australia.
- Non-standard sizes available, please contact Flexco.

Stock items (non-shaded) refer to (*) for specific lead time, if not specified, standard lead time applies.

Non-stock items (shaded) please contact Flexco for dispatch options and lead times.

Product Ordering Information

Inspection Doors

300 mm x 300 mm Door

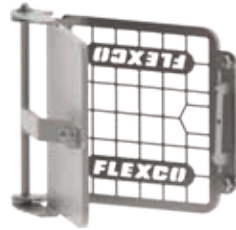

400 mm x 400 mm Door



500 mm x 500 mm Door



600 mm x 600 mm Door





Inspection Doors

Chute Opening mm	Item Code	Ordering Number	Weight kg
300 x 300	62445	ID300x300 S/S Inspection Door	8.0
400 x 400	62446	ID400x400 S/S Inspection Door	13.0
500 x 500	62447	ID500x500 S/S Inspection Door	18.0
600 x 600	62448	ID600x600 S/S Inspection Door	32.0

Product Notes:

- Please contact Flexco for pricing and lead time.
- The inspection doors are available in four different sizes to suit multiple chute openings
- Constructed from heavy-duty grade 316 stainless steel
- The solid outer door can be safely opened by hand without the need for any tools during normal operation of the equipment.
- The inner door features 3mm mesh at 50mm spacing and requires tools to remove ensuring workers remain safe behind the mesh.

 **Stock items** (non-shaded) refer to (*) for specific lead time, if not specified, standard lead time applies.

 **Non-stock items** (shaded) please contact Flexco for dispatch options and lead times.

Specifications & Guidelines

Inspection Doors

Inspection Door 300 mm x 300 mm

Chute Opening:	300 mm x 300 mm
Outer Door:	Solid c/w Lockable Handle
Inner Mesh Door:	3 mm mesh @ 50 mm spacing
Material:	Grade 316 Stainless Steel
Overall Weight:	8 kg

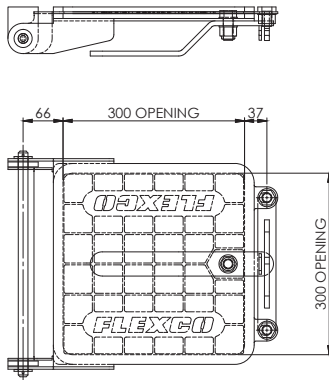

Inspection Door 400 mm x 400 mm

Chute Opening:	400 mm x 400 mm
Outer Door:	Solid c/w Lockable Handle
Inner Mesh Door:	3 mm mesh @ 50 mm spacing
Material:	Grade 316 Stainless Steel
Overall Weight:	13 kg

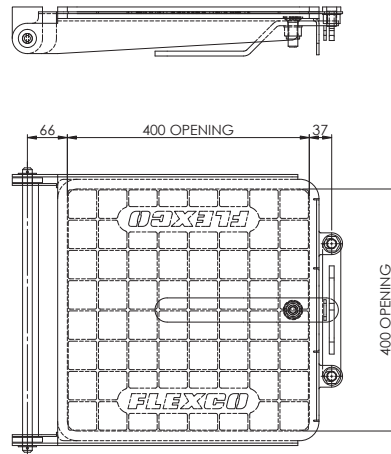

Inspection Door 500 mm x 500 mm

Chute Opening:	500 mm x 500 mm
Outer Door:	Solid c/w Lockable Handle
Inner Mesh Door:	3 mm mesh @ 50 mm spacing
Material:	Grade 316 Stainless Steel
Overall Weight:	18 kg

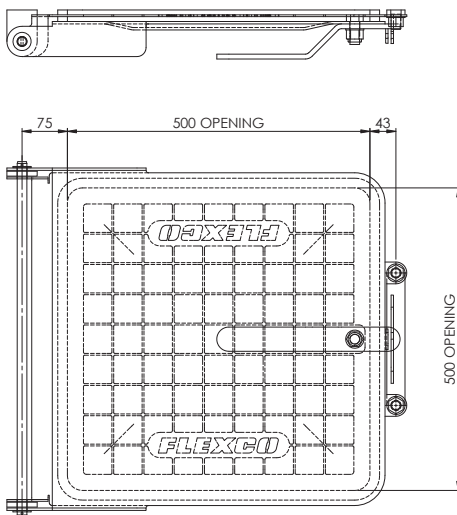

Inspection Door 600 mm x 600 mm

Chute Opening:	600 mm x 600 mm
Outer Door:	Solid c/w Lockable Handle
Inner Mesh Door:	3 mm mesh @ 50 mm spacing
Material:	Grade 316 Stainless Steel
Overall Weight:	32 kg

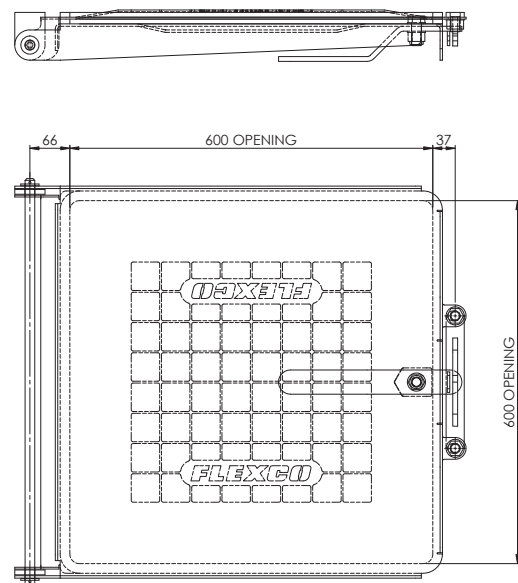

Product Ordering Information

Water Spray Pole Systems Belt Cleaner Accessories

Stand-Alone Spraybar Assemblies 38 mm dia.

BELT WIDTH mm	ORDERING NUMBER	ITEM CODE	WT. KG.
600	SB600A	A0887	4.0
750	SB750A	A0407	5.0
900	SB900A	A0912	5.5
1050	SB1050A	A0435	6.0
1200	SB1200A	A0316	7.0
1400	SB1400A	A1620	8.0
1500	SB1500A	A1838	9.0
1800	SB1800A	A1357	10.0

Spray Assembly includes spraybar, brass plug, y strainer, nozzles, and brackets to mount independently to structure.



Secondary Spraybar Assemblies

BELT WIDTH mm	ORDERING NUMBER	ITEM CODE	WT. KG.
600	SB600-SEC	61063	4.0
750	SB750-SEC	61064	5.0
900	SB900-SEC	61065	5.5
1050	SB1050-SEC	61066	6.0
1200	SB1200-SEC	61067	7.0
1400	SB1400-SEC	61068	8.0
1500	SB1500-SEC	61069	9.0
1800	SB1800-SEC	61070	10.0

Secondary Cleaner Spraybar Assemblies are designed to be clamped to secondary cleaners. Each assembly includes spraybar, nozzles, brass plug, y strainer, and clamping brackets to mount to secondary cleaner.

Lead time: 3 weeks

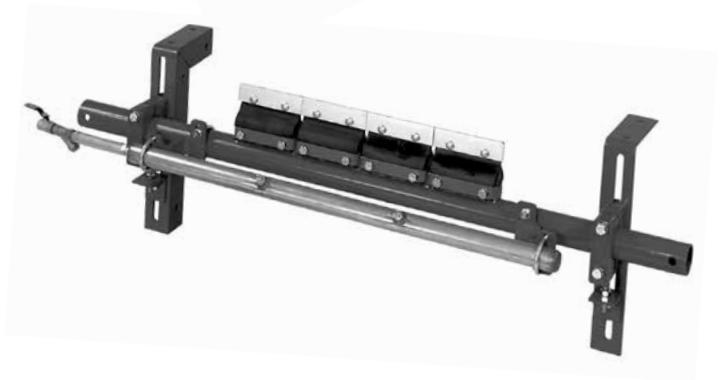

Water Control Manifold

ORDERING NUMBER	ITEM CODE	WT. KG.
WCB	A0012	10.0

Water Control Manifolds come complete with the following:

- 13 mm BSP connections
- Solenoid valve (24V DC Standard)
- Pressure regulator
- Filter strainer
- Lockable ball valves
- Manual bypass line
- Stainless steel backing plate



Spray Nozzles Per Cleaner Size

mm	450	600	750	900	1050	1200	1350	1500	1800	2100	2400	3000
Spray Nozzles	1	2	2	3	3	4	4	5	6	7	8	10

 Stock items (non-shaded) refer to (*) for specific lead time, if not specified, standard lead time applies.

 Non-stock items (shaded) please contact Flexco for dispatch options and lead times.

Product Ordering Information

Water Spray Pole Systems Belt Cleaner Accessories

PS Spraywash with V-Tips

BELT WIDTH mm	ORDERING NUMBER	ITEM CODE	WT. KG.
600	PS600	73014	27.0
750	PS750	73541	31.0
900	PS900	73542	33.0
1050	PS1050	73543	37.0
1200	PS1200	73544	40.0
1400	PS1400	73546	42.0
1500	PS1500	73545	47.0
1800	PS1800	73537	62.0
2000	PS2000	73539	68.0

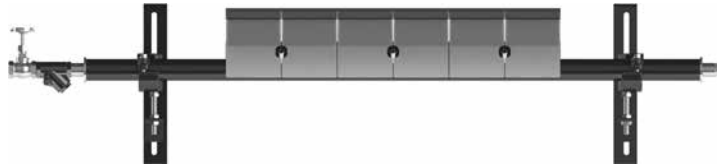

All Stainless Steel construction. Spraywash cleaners supplied standard with nozzles, deflector shields, Brass plug, and brass Y strainer.
Lead time: 3 weeks

Replacement Tips and Nozzles

BELT WIDTH mm	600	750	900	1050	1200	1400	1500	1800	2000
Tips/Cushions Required	4	5	6	7	8	9	10	12	13
Nozzles Required	2	3	3	3	4	5	5	6	7

Replacement Parts

REF	DESCRIPTION	POLE DIAMETER	BELT WIDTH	POLE LENGTH	ORDERING NUMBER	ITEM CODE	WT. KG.
1	PS Spray Poles	60	600	1350	PS600PL*	73582	15.0
			750	1500	PS750PL*	73583	16.0
			900	1650	PS900PL*	73584	19.0
			1050	1800	PS1050PL*	73585	22.0
			1200	1950	PS1200PL*	73586	26.0
		73	1400	2200	PS1400PL*	73587	29.0
			1500	2350	PS1500PL*	73588	33.0
			1800	2650	PS1800PL*	74049	36.0
			2000	2850	PS2000 PL*	74050	40.0
2	P-V Tip				PVT6-S/S	75420	0.4
3	PH High Speed Cushion - Stainless				PHSC-S/S	73433	1.0
4	Spray Nozzle				PSN11010	74053	1.0
5	Valve Assembly				PSVA	73434	1.0
6	Water Control Board - 24 Volt DC				WCB	A0012	10.0
-	Stainless Shield - Notch				PSSS-N	73221	0.5
-	Stainless Shield - Hole				PSSS-H	73222	0.5

Hardware included

*Lead time: 3 weeks

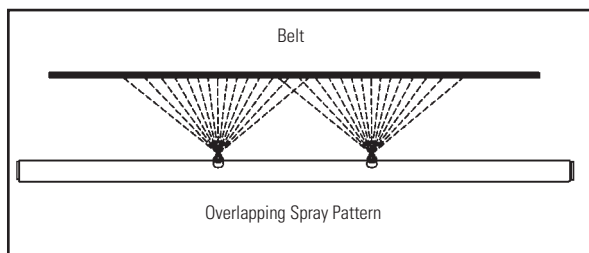

Specifications

- Stainless steel pole with stainless steel clamping brackets.
- Spray nozzles are spaced on 300 mm centers.
- Delivers 3.7 liters per nozzle per minute at 414 kPa.
- Maximum inlet pressure is 2069 kPa.
- Typical pressure setting is 276-414 kPa.

Stock items (non-shaded) refer to (*) for specific lead time, if not specified, standard lead time applies.

Non-stock items (shaded) please contact Flexco for dispatch options and lead times.

Product Ordering Information

Mandrel Safety Removal Systems Belt Cleaner Accessories

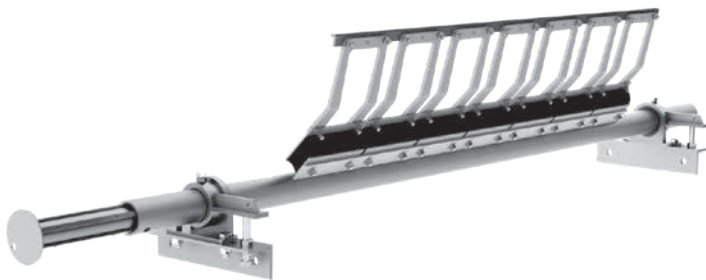

H-Type® primary cleaner shown (cleaner not included)

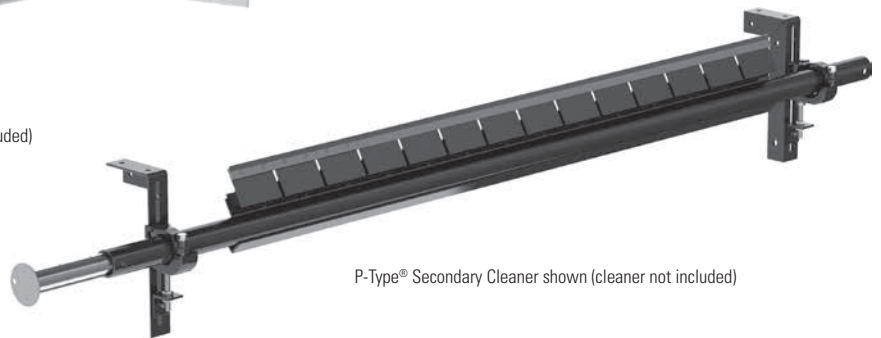

P-Type® Secondary Cleaner shown (cleaner not included)

Mandrel Poles

BELT WIDTH mm	CLEANER POLE DIA.	GALVANISED MANDREL POLE		
		ORDERING NUMBER	ITEM CODE	WT. KG.
450	60	MR-450PG	A2836	5.0
600	60	MR-600PG	A2837	6.0
750	60	MR-750PG	A2838	6.5
900	60	MR-900PG	A2839	7.5
1050	60	MR-1050PG	A2840	8.5
1200	60	MR-1200PG	A2841	9.0
1500	73	MR-1500PG	A2829	10.0
1600	73	MR-1600PG	A2830	11.0
1800	73	MR-1800PG	A2831	12.0
2100	73	MR-2100PG	A2832	13.5
2400	73	MR-2400PG	A2833	15.0
2600	73	MR-2600PG	A2834	16.5
3000	73	MR-3000PG	A2835	19.0

A Mandrel Kit requires 1 pole, 1 left hand block and 1 right hand block.

Lead time: 3 weeks

Cradle H Bearings Primary Cleaners

POWDER COATED			
ORDERING NUMBER	ITEM CODE	POLE DIA.	WT. KG.
PMR-CHB-L73	61075	73	1.5
PMR-CHB-R73	61076	73	1.5
PMR-CHB-L60	61073	60	1.3
PMR-CHB-R60	61074	60	1.3

Cradle Clamp Blocks Secondary Cleaners

POWDER COATED		
ORDERING NUMBER	ITEM CODE	POLE DIA.
SMR-CCB-L73	A2842	73
SMR-CCB-R73	A2843	73
SMR-CCB-L60	A2844	60
SMR-CCB-R60	A2845	60

Stock items (non-shaded) refer to (*) for specific lead time, if not specified, standard lead time applies.

Non-stock items (shaded) please contact Flexco for dispatch options and lead times.

Product Ordering Information

Live-Shaft Hold-Down Roll Belt Cleaner Accessories

Live-Shaft Hold-Down Roll

BELT WIDTH		ROLL DIAMETER		ORDERING NUMBER	ITEM CODE	WT. KG.
mm	in.	mm	in.			
600	24	114	4 1/2	HDR24	79010	72.3
750	30	114	4 1/2	HDR30	79011	76.8
900	36	114	4 1/2	HDR36	79012	81.8
1050	42	114	4 1/2	HDR42	79013	86.4
1200	48	114	4 1/2	HDR48	79014	113.2
1350	54	114	4 1/2	HDR54	79015	115.9
1500	60	114	4 1/2	HDR60	79016	120.5
1800	72	127	5	HDRS72*	79017	256.8
2100	84	127	5	HDRS84*	79018	279.5

*1800mm and 2100mm (72" and 84") feature solid roll

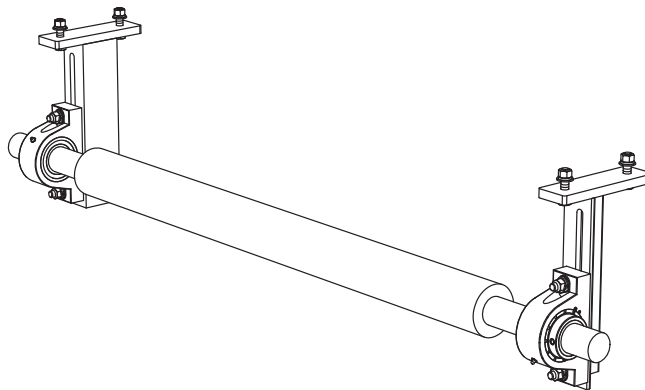

Replacement Roll

BELT WIDTH		ROLL DIAMETER		ORDERING NUMBER	ITEM CODE	WT. KG.
mm	in.	mm	in.			
600	24	114	4 1/2	HDRR24	79019	51.8
750	30	114	4 1/2	HDRR30	79020	56.4
900	36	114	4 1/2	HDRR36	79021	61.4
1050	42	114	4 1/2	HDRR42	79022	65.9
1200	48	114	4 1/2	HDRR48	79023	92.7
1350	54	114	4 1/2	HDRR54	79024	95.5
1500	60	114	4 1/2	HDRR60	79025	100.0
1800	72	127	5	HDRRS72*	79026	236.4
2100	84	127	5	HDRRS84*	79027	259.1

*1800mm and 2100mm (72" and 84") feature solid roll

Roller Bracket Kit*

DESCRIPTION	ORDERING NUMBER	ITEM CODE	WT. KG.
Hold Down Roll Bracket Kit - 600mm to 1500mm	HDRBK	79009	20.5
HD Hold Down Roll Bracket Kit - 1800mm to 2100mm	HDRBK-HD	79072	20.5

*Includes Left and Right Bracket

Add-On Grease Hose Extension Kit

DESCRIPTION	ORDERING NUMBER	ITEM CODE	WT. KG.
Grease Hose Extension Kit (incl. 2 ea. 400mm (16") hose w/fittings and tie-downs)	HDRGEK	79236	0.5

Specifications:

- Overall Roll Length.....Belt Width 150mm (+6")
- Overall Shaft LengthBelt Width 750mm (+30")
- Shaft Diameter.....600-1050mm (24"- 42") - 49.2mm (1-15/16") diameter
1200-1500mm (48"- 60") - 61.9mm (2-7/16") diameter
1800-2100mm (72"- 84") - 74.6 (2-15/16") diameter
- Shaft Construction600-1500mm (24"- 60") - 1045 CD
1800-2100mm (72"- 84") - turned from solid 4140 round stock

Product Notes:

- For use in applications with belt cup or belt flap.
- By preventing these issues secondary cleaner performance and blade/tip life is enhanced.

Stock items (non-shaded) refer to (*) for specific lead time, if not specified, standard lead time applies.

Non-stock items (shaded) please contact Flexco for dispatch options and lead times.

Product Ordering Information

Standard Pulley Lifters

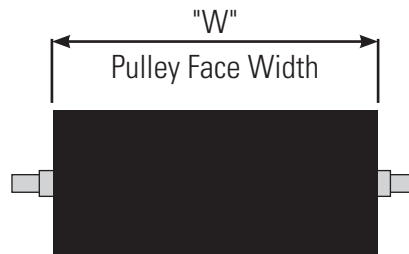



Pulley Face Widths

	800-1200	1200-1600	1600-2000	2000-2400
3 TONNE CAPACITY	1-PL-800-1200-3	1-PL-1200-1600-3	1-PL-1600-2000-3	1-PL-2000-2400-3
6 TONNE CAPACITY	1-PL-800-1200-6	1-PL-1200-1600-6	1-PL-1600-2000-6	1-PL-2000-2400-6
12 TONNE CAPACITY	1-PL-800-1200-12	1-PL-1200-1600-12	1-PL-1600-2000-12	1-PL-2000-2400-12

Product Notes:

- Please contact Flexco for pricing and lead times.
- Designed and manufactured in Bundaberg, QLD, Australia.
- Made from high strength steel to Australian Standards.
- Each pulley lifter proof load tested after manufacture and supplied with certificate of compliance and a safety operations and maintenance manual.
- Supplied in safety yellow as standard (other colours available on request).

 **Stock items** (non-shaded) refer to (*) for specific lead time, if not specified, standard lead time applies.

 **Non-stock items** (shaded) please contact Flexco for dispatch options and lead times.

Product Ordering Information

Belt Cleaner Accessories

Stabilising Roller Bracket Kit*

Provides universal brackets to mount the user's return roller as a hold-down (stabilising) roller on top of the return side belt. Holds the belt flat so the belt cleaner can maximize its cleaning performance.

DESCRIPTION	ORDERING NUMBER	ITEM CODE	WT. KG.
Stabilising Roller Bracket Kit	SRBK	74941	15.5

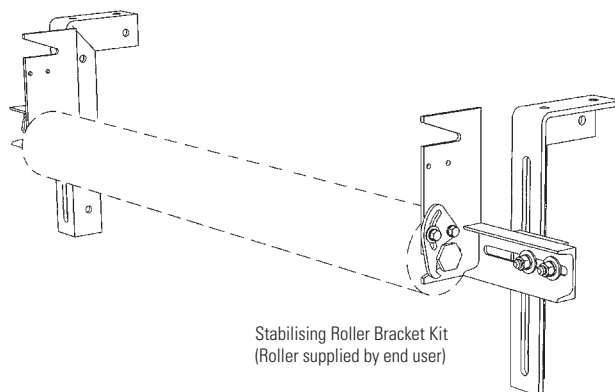

Hold Down Roll Assembly Kits

DESCRIPTION	ORDERING NUMBER	ITEM CODE	WT. KG.
Hold Down Roll Assembly Kit S/S 17mm*	HDRP17	63679	1.9
Hold Down Roll Assembly Kit S/S 22mm*	HDRP22	63678	1.9

Kit includes:

- Stainless Steel Hold Down Roller Pole Kit to suit 17mm or 22mm A/F Roller
- S/S Mounting Kit

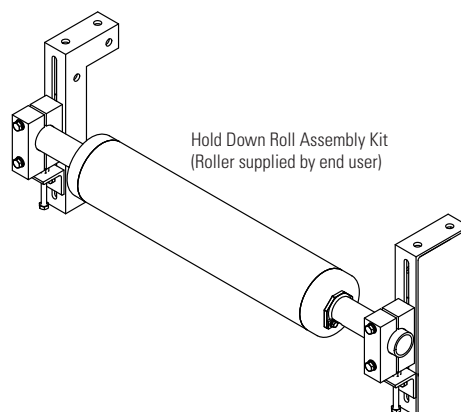

Tip Tension Scale

For easy checking of blade tension on all H-Type® Primary Cleaners.

DESCRIPTION	ORDERING NUMBER	ITEM CODE	WT. KG.
H Tip Tension Scale	HTTS	74141	0.1

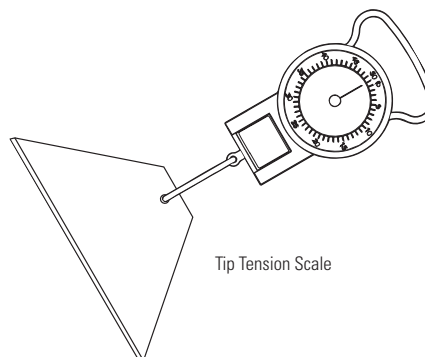

Spring Tension Chart (recommended tensions)

CLEANER	HXF	H V-TIP	H PROTECTED V-TIP	HI-TEMP V-TIP
Kg	12.7	8.2	8.2	8.2

For installation and for retensioning blades during maintenance.

Belt Cleaner Handy Wrench

A ratcheting wrench with 2 common socket sizes (11/16" & 3/4", 17mm & 19mm) for belt cleaner installation and maintenance.

DESCRIPTION	ORDERING NUMBER	ITEM CODE	WT. KG.
Belt Cleaner Handy Wrench	HW-BC	74100	0.6

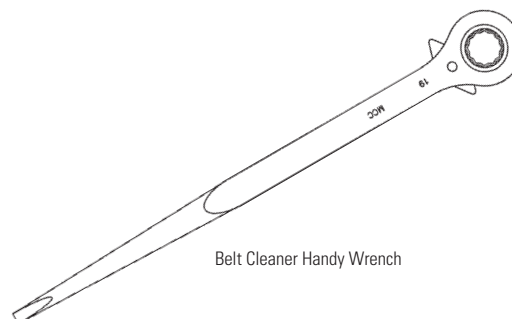

Stock items (non-shaded) refer to (*) for specific lead time, if not specified, standard lead time applies.

Non-stock items (shaded) please contact Flexco for dispatch options and lead times.

Product Ordering Information

Belt Cleaner Accessories

OPTIONAL MOUNTING KITS FOR BELT CLEANERS

Versatile, adjustable brackets and plates that can be mounted on the conveyor structure so Primary Cleaners and secondary cleaners can be easily and quickly bolted into place.



75830

- Optional Mounting Bar Kit (with bolts, nuts and washers)
- For mounting primary cleaners on open head pulleys.
 - Weld on both sides of pulley and bolt on steel plates.
 - For use with MMP, MHCP



76537

- Mounting Plate Kit (incl. 2 plates, 400 x 800 mm)
- For use with Mounting Bars to mount cleaners on open head pulleys.
 - For use with MMP, MHCP

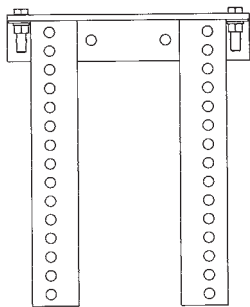

76071

- Standard Mounting Bracket Kit
- For most secondary cleaner installs.

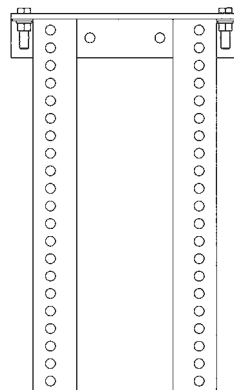

76072

- Long Mounting Bracket Kit
- For installations that require extra length legs.



76073

- Optional Top Angle Kit
- Used with both standard and long mounting bracket kits for additional mounting options.

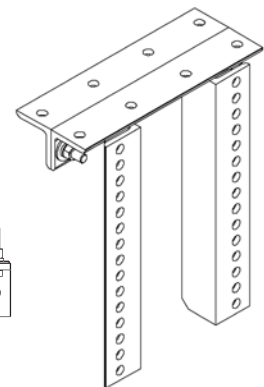

Optional Mounting Kits

(includes 2 brackets/bars)

DESCRIPTION	ORDERING NUMBER	ITEM CODE	WT. KG.
Standard Mounting Bracket Kit*	SSTSMB	76071	15.6
Long Mounting Bracket Kit*	SSTLMB	76072	19.7
Optional Top Angle Kit*	SSTOTA	76073	4.8
Optional Mounting Bar Kit*	MMBK	75830	8.8
Mounting Plate Kit (incl. 2 plates)	MMPK	76537	63.5

Hardware Included

Specifications

- Standard brackets are 330 mm W x 394 mm L.
- Long brackets are 330 mm W x 546 mm L.
- Mounting bars are 38 mm W x 406 mm L with (4) 16-279 mm tapped holes.
- Mounting plates are 406 mm W x 813 mm L with (4) 16 mm holes.

Pole Extender Kit

(includes 2 pole extenders)

DESCRIPTION	ORDERING NUMBER	ITEM CODE	WT. KG.
Pole Extender Kit	MAPEK	76024	9.9

Provides 750 mm of extended pole length.

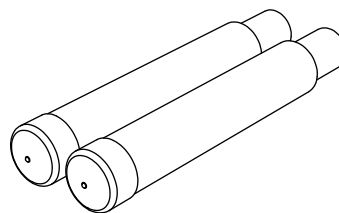

Stock items (non-shaded) refer to (*) for specific lead time, if not specified, standard lead time applies.

Non-stock items (shaded) please contact Flexco for dispatch options and lead times.

Specifications & Guidelines

Flexco® Slider/Impact Beds

Easy Solution for Load Zone Problems

- Complete load zone offering with slider beds through impact beds for up to 100 kg-m of force.
- No specifying trough angle; each bed is adjustable for 20°, 35° and 45° trough settings (ships at 35° setting)
- Low-profile installation. Because Flexco® beds feature trough wings that are adjustable, they lay flat during installation, providing more clearance.
- Full UHMW slider bars included on outside bar to provide proper sealing and long life.
- Unique Impact Bar Supports protect the impact bars from damage, extending service life. An Anti-Migratory Tab on each support secures the bar and prevents it from sliding in the direction of belt travel.
- All beds are manufactured for mounting holes belt width + 250mm (600-1200mm beds), + 300mm (1350-1500mm beds), and + 400mm (1800mm beds). For wider structure, contact Customer Service for special quote.

How to spec the correct slider/impact bed for your conveyor transfer point

Roller Size
 127mm 152mm 178mm
Belt Width: _____
Bed Length: 1200mm 1500mm

Impact Energy Calculation Chart

Impact Energy

Lump Weight (**w**) _____
 Drop Height (**h**) **x** _____

Total = **kg-m** See Below

0 kg-m — **EZSB-C**
 0 - 25kg-m — **EZSB-I or EZIB-L**
 25-100 kg-m — **EZIB-M**

Product Ordering Information

EZSB-C
Flexco® Slider Beds
CoreTech™ Rolls

Contact Flexco for information and pricing on shorter lead times and non-standard impact beds. Please note that freight for all impact beds are ex-works



Flexco Slider Bed with CoreTech™ Rolls 1200mm (for non-impact areas)

BELT WIDTH mm	ORDERING NUMBER	ITEM CODE	WT. KG.
600	EZSB600-1200C	82185	110.7
750	EZSB750-1200C	82186	119.4
900	EZSB900-1200C	82187	131.1
1050	EZSB1050-1200C	82188	162.7
1200	EZSB1200-1200C	82189	175.0
1350	EZSB1350-1200C	82190	206.4
1500	EZSB1500-1200C	82191	217.1
1800	EZSB1800-1200C	82192	232.7

Lead time: 4 weeks

Flexco Slider Bed with CoreTech™ Rolls 1500mm (for non-impact areas)

BELT WIDTH mm	ORDERING NUMBER	ITEM CODE	WT. KG.
600	EZSB600-1500C	82193	118.4
750	EZSB750-1500C	82194	126.9
900	EZSB900-1500C	82195	138.6
1050	EZSB1050-1500C	82196	173.7
1200	EZSB1200-1500C	82197	186.2
1350	EZSB1350-1500C	82198	221.4
1500	EZSB1500-1500C	82199	232.1
1800	EZSB1800-1500C	82200	247.6

Lead time: 4 weeks

Adjustable Idler Set with CoreTech™ Rolls

(for placement in between 3 or more beds)



BELT WIDTH mm	ORDERING NUMBER	ITEM CODE	WT. KG.
600	EZAI-600	82410	36.2
750	EZAI-750	82411	40.8
900	EZAI-900	82412	45.7
1050	EZAI-1050	82413	49.9
1200	EZAI-1200	82414	55.9
1350	EZAI-1350	82415	60.1
1500	EZAI-1500	82416	64.1
1800	EZAI-1800	82417	74.2

Lead time: 4 weeks

Product Notes:

- No need to specify troughing angle—designed to adjust to 20°, 35°, 45°.
- Designed for containment in the load zone, but not intended for impact zones.
- Slider bars are solid 25mm UHMW providing longer wear life and consistent load zone sealing.
- Product ships with two idlers. Additional idlers can be added by purchasing a EZRMK and the appropriate corresponding idler.

Replacement Parts List

EZSB-C
Flexco® Slider Beds
CoreTech™ Rolls

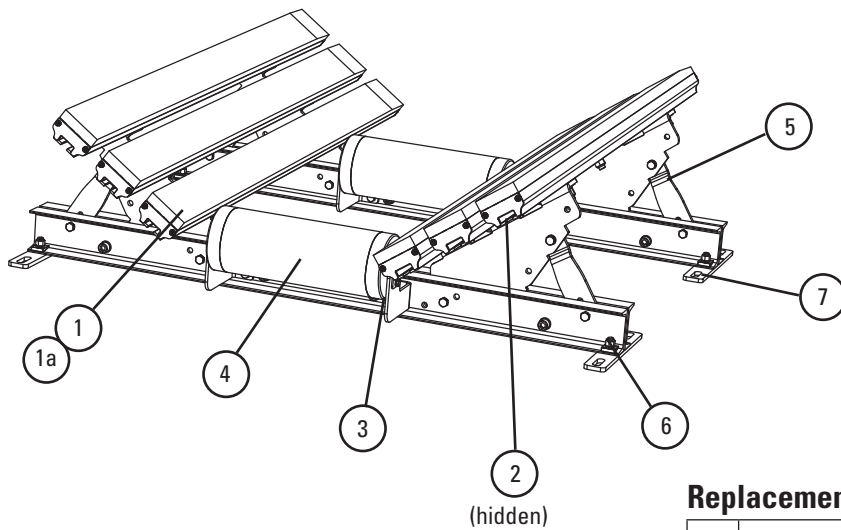

Replacement Parts

REF	DESCRIPTION	ORDERING NUMBER	ITEM CODE	WT. KG.
1	Slider Bar, 1200mm	SB4	78789	9.1
1a	Slider Bar, 1500mm	SB5	78790	10.9
2	Bar Bolt Kit (incl. 1 ea. 16mm carriage bolt, square washer, flat washer, lock washer, Nylock nut)	RIBBK	81250	0.2
3	Slider Roll Mount Kit*	EZRMM	82344	2.3
4	CoreTech™ Roll 600mm	N6D3T-24-9-A45	26107	4.1
	CoreTech Roll 750mm	N6D3T-30-11-A45	26108	4.8
	CoreTech Roll 900mm	N6D3T-36-13-A45	26109	5.6
	CoreTech Roll 1050mm	N6D3T-42-15-A45	26110	6.3
	CoreTech Roll 1200mm	N6D3T-48-17-A45	26111	7.3
	CoreTech Roll 1350mm	N6D3T-54-19-A45	26112	7.7
	CoreTech Roll 1500mm	N6D3T-60-21-A45	26113	8.2
	CoreTech Roll 1800mm	N6D3T-72-25-A45	26114	9.8
5	Wing Plate Kit 600mm*	EZWPK-600	82345	7.7
	Wing Plate Kit 750mm*	EZWPK-750	82346	7.9
	Wing Plate Kit 900mm*	EZWPK-900	82347	9.6
	Wing Plate Kit 1050mm*	EZWPK-1050	82348	11.9
	Wing Plate Kit 1200mm*	EZWPK-1200	82349	13.7
	Wing Plate Kit 1350mm*	EZWPK-1350	82350	16.1
	Wing Plate Kit 1500mm*	EZWPK-1500	82351	17.7
	Wing Plate Kit 1800mm*	EZWPK-1800	82352	21.2
6	Cross Stringer Kit 600mm*	EZCSK-600	82353	22.3
	Cross Stringer Kit 750mm*	EZCSK-750	82354	25.6
	Cross Stringer Kit 900mm*	EZCSK-900	82355	28.9
	Cross Stringer Kit 1050mm*	EZCSK-1050	82356	32.1
	Cross Stringer Kit 1200mm*	EZCSK-1200	82357	35.6
	Cross Stringer Kit 1350mm*	EZCSK-1350	82358	38.9
	Cross Stringer Kit 1500mm*	EZCSK-1500	82359	42.2
	Cross Stringer Kit 1800mm*	EZCSK-1800	82360	45.0
7	Shim Kit Light Duty (incl. 4 shims)	SHIM-LDKIT	82393	6.2

*Hardware Included. Lead time: 4 weeks.

Replacement Quantities for EZSB-C

mm	600	750	900	1050	1200	1350	1500	1800
ROLLS REQUIRED	2	2	2	2	2	2	2	2
BARS REQUIRED	SLIDER	4	4	4	6	6	8	8
BAR BOLT KITS REQUIRED	8	8	8	12	12	16	16	16

Product Ordering Information

EZSB-I **Flexco® Slider Beds** **CoreTech™ Impact Rolls**

Contact Flexco for information and pricing on shorter lead times and non-standard impact beds.
Please note that freight for all impact beds are ex-works



Flexco Slider Bed with CoreTech™ Impact Rolls 1200mm

(for impact zones with less than 25 Kg-m energy)

BELT WIDTH mm	ORDERING NUMBER	ITEM CODE	WT. KG.
600	EZSB600-1200I	82201	125.6
750	EZSB750-1200I	82202	136.1
900	EZSB900-1200I	82203	149.7
1050	EZSB1050-1200I	82204	184.7
1200	EZSB1200-1200I	82205	198.2
1350	EZSB1350-1200I	82206	233.1
1500	EZSB1500-1200I	82207	246.3
1800	EZSB1800-1200I	82208	265.8

Lead time: 4 weeks

Flexco Slider Bed with CoreTech™ Impact Rolls 1500mm

(for impact zones with less than 25 Kg-m energy)

BELT WIDTH mm	ORDERING NUMBER	ITEM CODE	WT. KG.
600	EZSB600-1500I	82209	133.4
750	EZSB750-1500I	82210	143.8
900	EZSB900-1500I	82211	157.5
1050	EZSB1050-1500I	82212	196.4
1200	EZSB1200-1500I	82213	210.0
1350	EZSB1350-1500I	82214	248.9
1500	EZSB1500-1500I	82215	262.1
1800	EZSB1800-1500I	82216	281.3

Product Notes:

- No need to specify troughing angle—designed to adjust to 20°, 35°, 45°.
- Outermost trough bar features 25mm solid UHMW slider bar to provide longer wear life and consistent load zone sealing where impact is not present.

Replacement Parts List

EZSB-I
Flexco® Slider Beds
CoreTech™ Impact Rolls

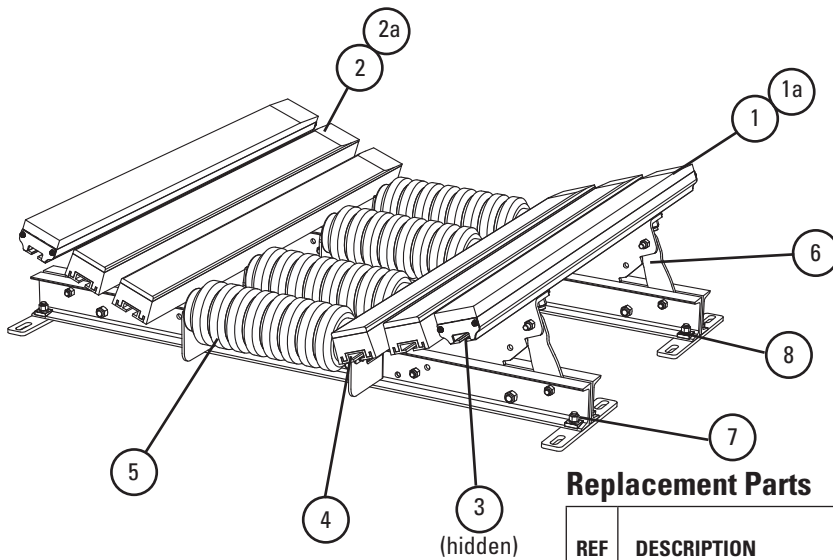

Replacement Parts

REF	DESCRIPTION	ORDERING NUMBER	ITEM CODE	WT. KG.
1	Slider Bar, 1200mm	SB4	78789	9.1
1a	Slider Bar, 1500mm	SB5	78790	10.9
2	Impact Bar, 1200mm	IB4	76926	7.7
2a	Impact Bar, 1500mm	IB5	76927	9.5
3	Bar Bolt Kit (incl. 1 ea. 16mm carriage bolt, square washer, flat washer, lock washer, Nylock nut)	RIBBK	81250	0.2
4	Slider Roll Mount Kit*	EZRMKM	82344	2.3
5	Impact CoreTech™ Roll 600mm	NI6D3T-24-9-A45	26184	4.6
	Impact CoreTech Roll 750mm	NI6D3T-30-11-A45	26185	5.4
	Impact CoreTech Roll 900mm	NI6D3T-36-13-A45	26186	6.3
	Impact CoreTech Roll 1050mm	NI6D3T-42-15-A45	26187	7.3
	Impact CoreTech Roll 1200mm	NI6D3T-48-17-A45	26188	8.1
	Impact CoreTech Roll 1350mm	NI6D3T-54-19-A45	26189	9.0
	Impact CoreTech Roll 1500mm	NI6D3T-60-21-A45	26190	9.8
	Impact CoreTech Roll 1800mm	NI6D3T-72-25-A45	26191	11.6
6	Wing Plate Kit 600mm*	EZWPK-600	82345	7.7
	Wing Plate Kit 750mm*	EZWPK-750	82346	7.9
	Wing Plate Kit 900mm*	EZWPK-900	82347	9.6
	Wing Plate Kit 1050mm*	EZWPK-1050	82348	11.9
	Wing Plate Kit 1200mm*	EZWPK-1200	82349	13.7
	Wing Plate Kit 1350mm*	EZWPK-1350	82350	16.1
	Wing Plate Kit 1500mm*	EZWPK-1500	82351	17.7
	Wing Plate Kit 1800mm*	EZWPK-1800	82352	21.2
7	Cross Stringer Kit 600mm*	EZCSK-600	82353	22.3
	Cross Stringer Kit 750mm*	EZCSK-750	82354	25.6
	Cross Stringer Kit 900mm*	EZCSK-900	82355	28.9
	Cross Stringer Kit 1050mm*	EZCSK-1050	82356	32.1
	Cross Stringer Kit 1200mm*	EZCSK-1200	82357	35.6
	Cross Stringer Kit 1350mm*	EZCSK-1350	82358	38.9
	Cross Stringer Kit 1500mm*	EZCSK-1500	82359	42.2
	Cross Stringer Kit 1800mm*	EZCSK-1800	82360	45.0
8	Shim Kit Light Duty (incl. 4 shims)	SHIM-LDKIT	82393	6.2

*Hardware Included. Lead time: 4 weeks.

Replacement Quantities for EZSB-I

mm	600	750	900	1050	1200	1350	1500	1800
ROLLS REQUIRED	4	4	4	4	4	4	4	4
BARS REQUIRED	SLIDER	2	2	2	2	2	2	2
	IMPACT	2	2	2	4	4	6	6
BAR BOLT KITS REQUIRED	8	8	8	12	12	16	16	16

Product Ordering Information

EZIB-L **Flexco® Impact Beds** *All Bars - Light Duty*

Contact Flexco for information and pricing on shorter lead times and non-standard impact beds. Please note that freight for all impact beds are ex-works



Flexco® Impact Bed Light Duty 1200mm

(for impact zones with less than 25 Kg-m energy)

BELT WIDTH mm	ORDERING NUMBER	ITEM CODE	WT. KG.
600	EZIB600-1200L	82217	138.0
750	EZIB750-1200L	82218	145.6
900	EZIB900-1200L	82219	174.5
1050	EZIB1050-1200L	82220	206.1
1200	EZIB1200-1200L	82221	235.1
1350	EZIB1350-1200L	82222	267.2
1500	EZIB1500-1200L	82223	295.7
1800	EZIB1800-1200L	82224	327.3

Lead time: 4 weeks

Flexco Impact Bed Light Duty 1500mm

(for impact zones with less than 25 Kg-m energy)

BELT WIDTH mm	ORDERING NUMBER	ITEM CODE	WT. KG.
600	EZIB600-1500L	82225	153.7
750	EZIB750-1500L	82226	161.3
900	EZIB900-1500L	82227	194.2
1050	EZIB1050-1500L	82228	229.7
1200	EZIB1200-1500L	82229	262.8
1350	EZIB1350-1500L	82230	298.8
1500	EZIB1500-1500L	82231	331.1
1800	EZIB1800-1500L	82232	366.8

Lead time: 4 weeks

Product Notes:

- No need to specify troughing angle—designed to adjust to 20°, 35°, 45°.
- Outermost trough bar features 25mm solid UHMW slider bar to provide longer wear life and consistent load zone sealing where impact is not present.

Replacement Parts List

EZIB-L
Flexco® Impact Beds
All Bars - Light Duty

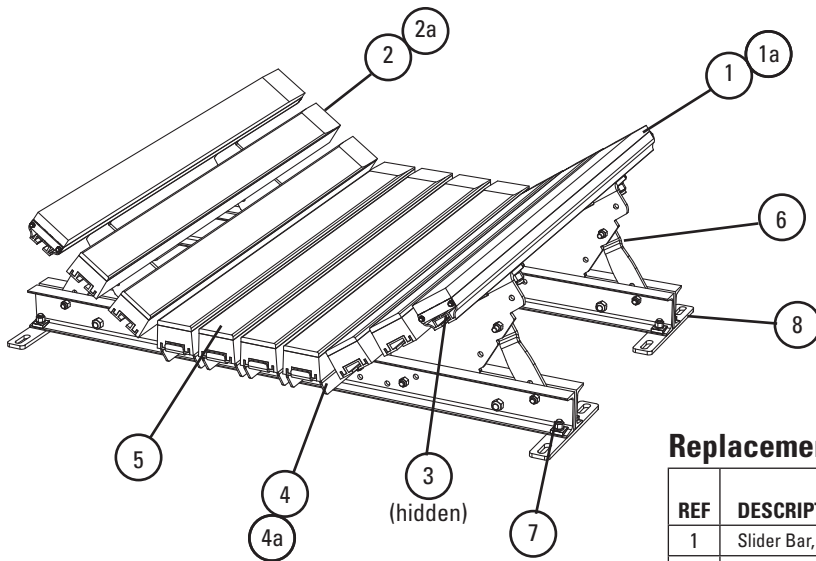

Replacement Parts

REF	DESCRIPTION	ORDERING NUMBER	ITEM CODE	WT. KG.
1	Slider Bar, 1200mm	SB4	78789	9.1
1a	Slider Bar, 1500mm	SB5	78790	10.9
2	Impact Bar, 1200mm	IB4	76926	7.7
2a	Impact Bar, 1500mm	IB5	76927	9.5
3	Bar Bolt Kit (incl. 1 ea. 16mm carriage bolt, square washer, flat washer, lock washer, Nylock nut)	RIBBK	81250	0.2
4	Impact Bar Support - 1.2M*	EZBS-1200	82361	7.3
4a	Impact Bar Support - 1.5M*	EZBS-1500	82362	9.3
5	Centre Bar Mount Kit 600mm*	EZBMK-600	82281	2.4
	Centre Bar Mount Kit 750mm*	EZBMK-750	82282	2.6
	Centre Bar Mount Kit 900mm*	EZBMK-900	82283	3.4
	Centre Bar Mount Kit 1050mm*	EZBMK-1050	82284	3.6
	Centre Bar Mount Kit 1200mm*	EZBMK-1200	82285	4.4
	Centre Bar Mount Kit 1350mm*	EZBMK-1350	82286	4.8
	Centre Bar Mount Kit 1500mm*	EZBMK-1500	82287	5.6
	Centre Bar Mount Kit 1800mm*	EZBMK-1800	82288	6.6
6	Wing Plate Kit 600mm*	EZWPK-600	82345	7.7
	Wing Plate Kit 750mm*	EZWPK-750	82346	7.9
	Wing Plate Kit 900mm*	EZWPK-900	82347	9.6
	Wing Plate Kit 1050mm*	EZWPK-1050	82348	11.9
	Wing Plate Kit 1200mm*	EZWPK-1200	82349	13.7
	Wing Plate Kit 1350mm*	EZWPK-1350	82350	16.1
	Wing Plate Kit 1500mm*	EZWPK-1500	82351	17.7
	Wing Plate Kit 1800mm*	EZWPK-1800	82352	21.2
7	Cross Stringer Kit 600mm*	EZCSK-600	82353	22.3
	Cross Stringer Kit 750mm*	EZCSK-750	82354	25.6
	Cross Stringer Kit 900mm*	EZCSK-900	82355	28.9
	Cross Stringer Kit 1050mm*	EZCSK-1050	82356	32.1
	Cross Stringer Kit 1200mm*	EZCSK-1200	82357	35.6
	Cross Stringer Kit 1350mm*	EZCSK-1350	82358	38.9
	Cross Stringer Kit 1500mm*	EZCSK-1500	82359	42.2
	Cross Stringer Kit 1800mm*	EZCSK-1800	82360	45.0
8	Shim Kit Light Duty (incl. 4 shims)	SHIM-LDKIT	82393	6.2

*Hardware Included. Lead time: 4 weeks.

Replacement Quantities for EZIB-L

mm	600	750	900	1050	1200	1350	1500	1800
BARS REQUIRED	SLIDER	2	2	2	2	2	2	2
	IMPACT	4	4	5	7	8	10	11
BAR BOLT KITS REQUIRED	14	14	17	21	24	28	31	34
BAR SUPPORTS REQUIRED	2	2	3	3	4	4	5	6

Product Ordering Information

EZIB-M **Flexco® Impact Beds** *All Bars - Medium Duty*

Contact Flexco for information and pricing on shorter lead times and non-standard impact beds.
Please note that freight for all impact beds are ex-works



Flexco® Impact Bed Medium Duty 1200mm

(for impact zones with 25-100 Kg-m energy)

BELT WIDTH mm	ORDERING NUMBER	ITEM CODE	WT. KG.
600	EZIB600-1200M	82233	185.7
750	EZIB750-1200M	82234	197.1
900	EZIB900-1200M	82235	214.7
1050	EZIB1050-1200M	82236	269.9
1200	EZIB1200-1200M	82237	305.2
1350	EZIB1350-1200M	82238	343.8
1500	EZIB1500-1200M	82239	361.1
1800	EZIB1800-1200M	82240	382.9

Lead time: 4 weeks

Flexco Impact Bed Medium Duty 1500mm

(for impact zones with 25-100 Kg-m energy)

BELT WIDTH mm	ORDERING NUMBER	ITEM CODE	WT. KG.
600	EZIB600-1500M	82241	205.3
750	EZIB750-1500M	82242	216.6
900	EZIB900-1500M	82243	234.3
1050	EZIB1050-1500M	82244	297.4
1200	EZIB1200-1500M	82245	336.7
1350	EZIB1350-1500M	82246	379.3
1500	EZIB1500-1500M	82247	396.6
1800	EZIB1800-1500M	82248	461.0

Lead time: 4 weeks

Product Notes:

- No need to specify troughing angle—designed to adjust to 20°, 35°, 45°.
- Outermost trough bar features 25mm solid UHMW slider bar to provide longer wear life and consistent load zone sealing where impact is not present.

Replacement Parts List

EZIB-M
Flexco® Impact Beds
 All Bars - Medium Duty

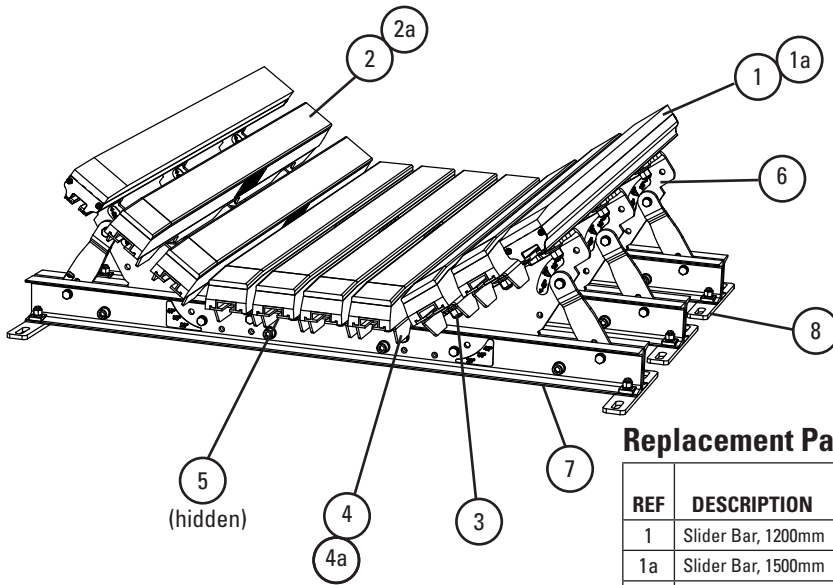

Replacement Parts

REF	DESCRIPTION	ORDERING NUMBER	ITEM CODE	WT. KG.
1	Slider Bar, 1200mm	SB4	78789	9.1
1a	Slider Bar, 1500mm	SB5	78790	10.9
2	Impact Bar, 1200mm	IB4	76926	7.7
2a	Impact Bar, 1500mm	IB5	76927	9.5
3	Bar Bolt Kit (incl. 1 ea. 16mm carriage bolt, square washer, flat washer, lock washer, Nylock nut)	RIBBK	81250	0.2
4	Impact Bar Support - 1200mm*	IBS-M1200	82397	7.7
4a	Impact Bar Support - 1500mm*	IBS-M1500	82398	9.6
5	Centre Bar Mount Kit 600mm*	EZBMK-600	82281	2.4
	Centre Bar Mount Kit 750mm*	EZBMK-750	82282	2.6
	Centre Bar Mount Kit 900mm*	EZBMK-900	82283	3.4
	Centre Bar Mount Kit 1050mm*	EZBMK-1050	82284	3.6
	Centre Bar Mount Kit 1200mm*	EZBMK-1200	82285	4.4
	Centre Bar Mount Kit 1350mm*	EZBMK-1350	82286	4.8
	Centre Bar Mount Kit 1500mm*	EZBMK-1500	82287	5.6
	Centre Bar Mount Kit 1800mm*	EZBMK-1800	82288	6.6
6	Wing Plate Kit 600mm*	EZWPK-600	82345	7.7
	Wing Plate Kit 750mm*	EZWPK-750	82346	7.9
	Wing Plate Kit 900mm*	EZWPK-900	82347	9.6
	Wing Plate Kit 1050mm*	EZWPK-1050	82348	11.9
	Wing Plate Kit 1200mm*	EZWPK-1200	82349	13.7
	Wing Plate Kit 1350mm*	EZWPK-1350	82350	16.1
	Wing Plate Kit 1500mm*	EZWPK-1500	82351	17.7
7	Wing Plate Kit 1800mm*	EZWPK-1800	82352	21.2
	Cross Stringer Kit 600mm*	EZCSK-600	82353	22.3
	Cross Stringer Kit 750mm*	EZCSK-750	82354	25.6
	Cross Stringer Kit 900mm*	EZCSK-900	82355	28.9
	Cross Stringer Kit 1050mm*	EZCSK-1050	82356	32.1
	Cross Stringer Kit 1200mm*	EZCSK-1200	82357	35.6
	Cross Stringer Kit 1350mm*	EZCSK-1350	82358	38.9
	Cross Stringer Kit 1500mm*	EZCSK-1500	82359	42.2
8	Shim Kit Medium Duty (incl. 4 shims)	SHIM-MDKIT	82394	9.3

*Hardware Included. Lead time: 4 weeks.

Replacement Quantities for EZIB-M

mm		600	750	900	1050	1200	1350	1500	1800
BARS REQUIRED	SLIDER	2	2	2	2	2	2	2	2
	IMPACT	4	4	5	7	8	10	11	12
BAR BOLT KITS REQUIRED		26	26	31	37	42	48	53	58
BAR SUPPORTS REQUIRED		4	4	5	5	6	6	7	8

It's the Structure, not the bars

It absorbs more impact to save your belt. Our exclusive Velocity Reduction Technology™ provides two levels of impact relief.

Level 1: **Impact Bars** first absorb impact energy. Unique Impact Bar Supports on all DRX™ Impact Beds allow the impact bars to function properly - expanding and absorbing more impact energy.

Level 2: On DRX200, 750 and 1500 impact beds, **Isolation Mounts** provide a second level of reaction force reduction, absorbing additional impact energy and minimising transmission back to the belt. The DRX3000 Dynamic has **Impact Energy Absorbers** to disperse an immense amount of impact, even in extremely severe applications.

User-Friendly Slide-Out Service™

- All DRX Impact Beds separate in the middle to slide apart and out.
- Can be easily and safely converted from the run position to the service position.
- Impact bars are easy to get to for changeout. A complete changeout can be done in one or two hours.

Unique Impact Bar Supports protect the impact bars from damage, extending service life. An Anti-Migratory Tab on each support secures the bar and prevents it from sliding in the direction of the belt.

Other Features and Benefits

- Uses exclusive anti-spin square washers. Allows use of carriage bolts to secure impact bars instead of expensive T bolts.
- Centre bars are tilted 3° inward to help centre the load on the belt.

How to spec the correct impact bed for your conveyor transfer point

Impact Energy Calculation Chart

Largest Material Lump Weight (w)

Drop Height (h)

ROLLER SIZE

127 mm 152 mm

Belt Width _____

Troughing Angle: 20° 35°

Bed Length: 1.2 M 1.5 M

IMPACT ENERGY

Lump Weight (w) _____

Drop Height (h) x _____

Total=kg/Mtr _____ See Below

Up to 25 kg-m—DRX200

25 to 100 kg-m—DRX750

100 to 200 kg-m—DRX1500

200 to 400 kg-m—DRX3000

(w) refer to (*) for specific lead time, if lead time applies.
(h) please contact Flexco for dispatch options and lead times.

Product Ordering Information

DRX™200
Impact Beds

DRX™200

1.2 M Beds, 20° Trough

BELT WIDTH mm	ORDERING NUMBER	ITEM CODE	WT. KG.
600	DRXL-24-420	76816	118.2
750	DRXL-30-420	76817	128.2
900	DRXL-36-420	76818	146.8
1050	DRXL-42-420	76819	187.3
1200	DRXL-48-420	76820	196.8
1350	DRXL-54-420	76821	226.4
1500	DRXL-60-420	76822	246.8
1800	DRXL-72-420	76823	279.6

DRX200

1.5 M Beds, 20° Trough

BELT WIDTH mm	ORDERING NUMBER	ITEM CODE	WT. KG.
600	DRXL-24-520	76824	131.8
750	DRXL-30-520	76825	141.4
900	DRXL-36-520	76826	162.3
1050	DRXL-42-520	76827	208.6
1200	DRXL-48-520	76828	218.2
1350	DRXL-54-520	76829	251.8
1500	DRXL-60-520	76830	273.6
1800	DRXL-72-520	76831	308.6

DRX200

1.2 M Beds, 35° Trough

BELT WIDTH mm	ORDERING NUMBER	ITEM CODE	WT. KG.
600	DRXL-24-435	76832	118.2
750	DRXL-30-435	76833	128.2
900	DRXL-36-435	76834	146.8
1050	DRXL-42-435	76835	187.3
1200	DRXL-48-435	76836	196.8
1350	DRXL-54-435	76837	226.4
1500	DRXL-60-435	76838	246.8
1800	DRXL-72-435	76839	279.6

DRX200

1.5 M Beds, 35° Trough

BELT WIDTH mm	ORDERING NUMBER	ITEM CODE	WT. KG.
600	DRXL-24-535	76840	131.8
750	DRXL-30-535	76841	141.4
900	DRXL-36-535	76842	162.3
1050	DRXL-42-535	76843	208.6
1200	DRXL-48-535	76844	218.2
1350	DRXL-54-535	76845	251.8
1500	DRXL-60-535	76846	273.6
1800	DRXL-72-535	76847	308.6

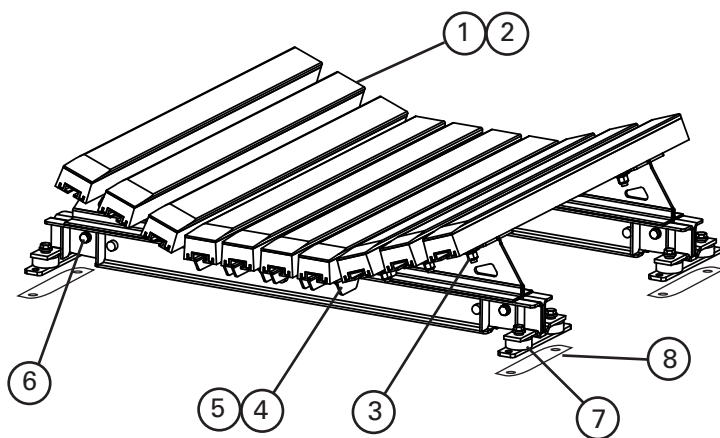

Replacement Bars and Bolt Kits Required per Belt Width-DRX200

BELT WIDTH mm	600	750	900	1050	1200	1350	1500	1800
Impact Bar Supports Required	2	2	3	4	4	4	5	6
Impact Bars Required	6	6	7	10	10	12	13	14
Impact Bar Bolt Kits Required	14	14	17	24	24	28	31	34

Replacement Parts

REF	DESCRIPTION	ORDERING NUMBER	ITEM CODE	WT. KG.
1	Impact Bar, 1.2 M	IB4	76926	7.7
2	Impact Bar, 1.5 M	IB5	76927	9.6
3	Impact Bar Bolt Kit incl. (1) ea 16 mm carriage bolt, square washer, flat washer, lock washer, Nylock nut	IBBK	76928	0.2
4	Impact Bar Support -L 1.2 M incl. (1) ea bar support, carriage bolt, square washer, lock washer, Nylock nut	IBS-L4	76929	7.6
5	Impact Bar Support -L 1.5 M incl. (1) ea bar support, carriage bolt, square washer, lock washer, Nylock nut	IBS-L5	76930	9.6
6	Sliding Support Arm Bolt Kit incl. (2) 50 mm bolts, (2) lock washers, (2) Nylock nuts	ISABK-LMH	77529	0.9
7	Isolation Mount Kit	IMK	76936	1.7
8	DRX200 Shim Kit (incl. 4 shims)	SHIM-KITL	77548	6.1

Stock items (non-shaded) refer to (*) for specific lead time, if not specified, standard 12 week lead time applies.

Non-stock items (shaded) please contact Flexco for dispatch options and lead times.

Product Ordering Information

DRX™750
Impact Beds

DRX™750

1.2 M Beds, 20° Trough

BELT WIDTH mm	ORDERING NUMBER	ITEM CODE	WT. KG.
600	DRXM-24-420	76848	165.9
750	DRXM-30-420	76849	180.5
900	DRXM-36-420	76850	212.3
1050	DRXM-42-420	76851	269.1
1200	DRXM-48-420	76852	283.2
1350	DRXM-54-420	76853	320.0
1500	DRXM-60-420	76854	354.1
1800	DRXM-72-420	76855	407.3

DRX750

1.5 M Beds, 20° Trough

BELT WIDTH mm	ORDERING NUMBER	ITEM CODE	WT. KG.
600	DRXM-24-520	76856	183.2
750	DRXM-30-520	76857	197.7
900	DRXM-36-520	76858	233.6
1050	DRXM-42-520	76859	298.2
1200	DRXM-48-520	76860	312.3
1350	DRXM-54-520	76861	353.2
1500	DRXM-60-520	76862	391.4
1800	DRXM-72-520	76863	447.7

DRX750

1.2 M Beds, 35° Trough

BELT WIDTH mm	ORDERING NUMBER	ITEM CODE	WT. KG.
600	DRXM-24-435	76864	165.9
750	DRXM-30-435	76865	180.5
900	DRXM-36-435	76866	212.3
1050	DRXM-42-435	76867	269.1
1200	DRXM-48-435	76868	283.2
1350	DRXM-54-435	76869	320.0
1500	DRXM-60-435	76870	354.1
1800	DRXM-72-435	76871	407.3

DRX750

1.5 M Beds, 35° Trough

BELT WIDTH mm	ORDERING NUMBER	ITEM CODE	WT. KG.
600	DRXM-24-535	76872	183.2
750	DRXM-30-535	76873	197.7
900	DRXM-36-535	76874	233.6
1050	DRXM-42-535	76875	298.2
1200	DRXM-48-535	76876	312.3
1350	DRXM-54-535	76877	353.2
1500	DRXM-60-535	76878	391.4
1800	DRXM-72-535	76879	447.7

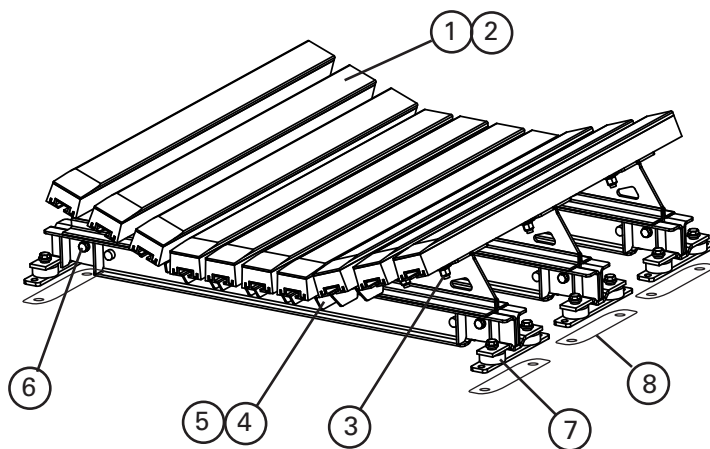

Replacement Bars and Bolt Kits Required per Belt Width-DRX750

BELT WIDTH mm	600	750	900	1050	1200	1350	1500	1800
Impact Bar Supports Required	4	4	5	6	6	6	7	8
Impact Bars Required	6	6	7	10	10	12	13	14
Impact Bar Bolt Kits Required	26	26	31	42	42	48	53	58

Replacement Parts

REF	DESCRIPTION	ORDERING NUMBER	ITEM CODE	WT. KG.
1	Impact Bar, 1.2 M	IB4	76926	7.7
2	Impact Bar, 1.5 M	IB5	76927	9.6
3	Impact Bar Bolt Kit incl. (1) ea 16 mm carriage bolt, square washer, flat washer, lock washer, Nylock nut	IBBK	76928	0.2
4	Impact Bar Support -M 1.2 M incl. (1) bar support, (2) ea carriage bolt, square washer, lock washer, Nylock nut	IBS-M4	76931	7.7
5	Impact Bar Support -M 1.5 M incl. (1) bar support, (2) ea carriage bolt, square washer, lock washer, Nylock nut	IBS-M5	76932	9.6
6	Sliding Support Arm Bolt Kit incl. (2) 50 mm bolts, (2) lock washers, (2) Nylock nuts	ISABK-LMH	77529	0.9
7	Isolation Mount Kit	IMK	76936	1.7
8	DRX750 Shim Kit (incl. 6 shims)	SHIM-KITM	77549	9.3

Stock items (non-shaded) refer to (*) for specific lead time, if not specified, standard 12 week lead time applies.

Non-stock items (shaded) please contact Flexco for dispatch options and lead times.

Product Ordering Information

DRX™ 1500
Impact Beds

DRX™1500

1.2 M Beds, 20° Trough

BELT WIDTH mm	ORDERING NUMBER	ITEM CODE	WT. KG.
600	DRXH-24-420	76880	228.6
750	DRXH-30-420	76881	247.7
900	DRXH-36-420	76882	285.5
1050	DRXH-42-420	76883	366.4
1200	DRXH-48-420	76884	385.0
1350	DRXH-54-420	76885	444.1
1500	DRXH-60-420	76886	484.6
1800	DRXH-72-420	76887	550.0

DRX1500

1.5 M Beds, 20° Trough

BELT WIDTH mm	ORDERING NUMBER	ITEM CODE	WT. KG.
600	DRXH-24-520	76888	253.6
750	DRXH-30-520	76889	273.2
900	DRXH-36-520	76890	314.6
1050	DRXH-42-520	76891	407.3
1200	DRXH-48-520	76892	425.9
1350	DRXH-54-520	76893	492.7
1500	DRXH-60-520	76894	536.8
1800	DRXH-72-520	76895	606.4

DRX1500

1.2 M Beds, 35° Trough

BELT WIDTH mm	ORDERING NUMBER	ITEM CODE	WT. KG.
600	DRXH-24-435	76896	228.6
750	DRXH-30-435	76897	247.7
900	DRXH-36-435	76898	285.5
1050	DRXH-42-435	76899	366.4
1200	DRXH-48-435	76900	385.0
1350	DRXH-54-435	76901	444.1
1500	DRXH-60-435	76902	484.6
1800	DRXH-72-435	76903	550.0

DRX1500

1.5 M Beds, 35° Trough

BELT WIDTH mm	ORDERING NUMBER	ITEM CODE	WT. KG.
600	DRXH-24-535	76904	253.6
750	DRXH-30-535	76905	273.2
900	DRXH-36-535	76906	314.6
1050	DRXH-42-535	76907	407.3
1200	DRXH-48-535	76908	425.9
1350	DRXH-54-535	76909	492.7
1500	DRXH-60-535	76910	536.8
1800	DRXH-72-535	76911	606.4

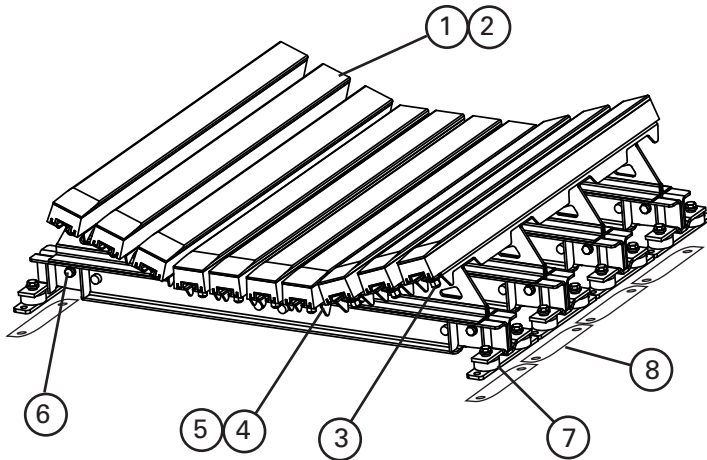

Replacement Parts

REF	DESCRIPTION	ORDERING NUMBER	ITEM CODE	WT. KG.
1	Impact Bar, 1.2 M	IB4	76926	7.7
2	Impact Bar, 1.5 M	IB5	76927	9.6
3	Impact Bar Bolt Kit incl. (1) ea 16 mm carriage bolt, square washer, flat washer, lock washer, Nylock nut	IBBK	76928	0.2
4	Impact Bar Support -H 1.2 M incl. (1) bar support, (2) ea carriage bolt, square washer, lock washer, Nylock nut	IBS-H4	76933	7.6
5	Impact Bar Support -DH 1.5 M incl. (1) bar support, (2) ea carriage bolt, square washer, lock washer, Nylock nut	IBS-DH5	76934	9.6
6	Sliding Support Arm Bolt Kit incl. (2) 50 mm bolts, (2) lock washers, (2) Nylock nuts	ISABK-LMH	77529	0.9
7	Isolation Mount Kit	IMK	76936	1.7
8	DRX1500 Shim Kit (incl. 8 shims)	SHIM-KITH	77550	12.3

Replacement Bars and Bolt Kits Required per Belt Width-DRX1500

BELT WIDTH mm	600	750	900	1050	1200	1350	1500	1800
Impact Bar Supports Required	6	6	7	10	10	12	13	14
Impact Bars Required	6	6	7	10	10	12	13	14
Impact Bar Bolt Kits Required	36	36	42	60	60	72	78	84

Stock items (non-shaded) refer to (*) for specific lead time, if not specified, standard 12 week lead time applies.

Non-stock items (shaded) please contact Flexco for dispatch options and lead times.

Product Ordering Information

DRX™3000
Dynamic Beds

DRX™3000

1.5 M Beds, 20° Trough

BELT WIDTH mm	ORDERING NUMBER	ITEM CODE	WT. KG.
1050	DRXD-42-520	76912	614.1
1200	DRXD-48-520	76913	639.6
1350	DRXD-54-520	76914	712.7
1500	DRXD-60-520	76915	761.8
1800	DRXD-72-520	76916	953.6
2100	DRXD-84-520	76917	1027.7
2400	DRXD-96-520	76918	1185.9

DRX3000

1.5 M Beds, 35° Trough

BELT WIDTH mm	ORDERING NUMBER	ITEM CODE	WT. KG.
1050	DRXD-42-535	76919	614.1
1200	DRXD-48-535	76920	639.6
1350	DRXD-54-535	76921	712.7
1500	DRXD-60-535	76922	761.8
1800	DRXD-72-535	76923	953.6
2100	DRXD-84-535	76924	1027.7
2400	DRXD-96-535	76925	1185.9

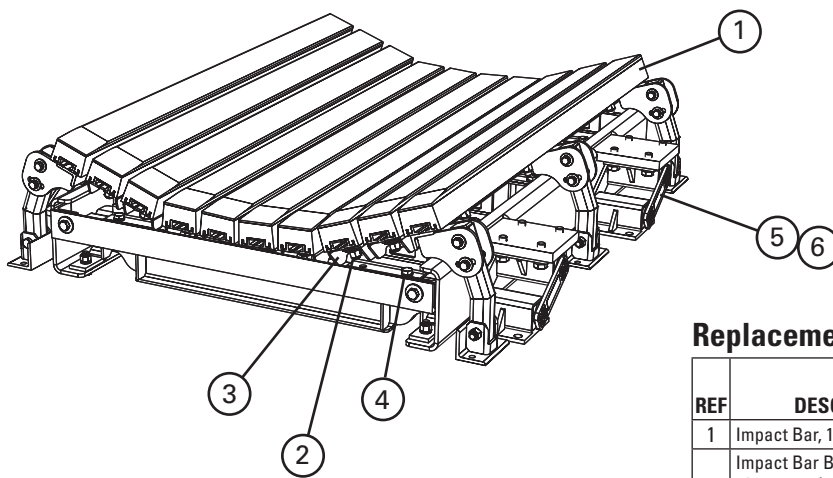

Replacement Bars and Bolt Kits Required per Belt Width-DRX3000

BELT WIDTH mm	1050	1200	1350	1500	1800	2100	2400
Impact Bars Required	10	10	12	13	16	16	20
Impact Bar Bolt Kits Required	56	56	64	70	88	88	112

Replacement Parts

REF	DESCRIPTION	ORDERING NUMBER	ITEM CODE	WT. KG.
1	Impact Bar, 1.5 M	IB5	76927	9.6
2	Impact Bar Bolt Kit incl. (1) ea 16 mm carriage bolt, square washer, flat washer, lock washer, Nylock nut	IBBK	76928	0.2
3	Impact Bar Support - DH 1.5 M incl. (1) bar support, (2) ea carriage bolt, square washer, lock washer, Nylock nut	IBS-DH5	76934	9.6
4	Sliding Support Arm Bolt Kit incl. (4) 38 mm bolts, (2) 51 mm bolts, (6) lock washers, (6) Nylock nuts	ISABK	76935	0.9
5	Impact Energy Absorber 42-60	IEA42-60D	76937	19.1
6	Impact Energy Absorber 72-96	IEA72-96D	76938	30.0

Impact Bar Supports per Belt Width

BELT WIDTH mm	1050	1200	1350	1500	1800	2100	2400
Impact Bar Supports	8	8	8	9	12	12	16

Product Notes:

- For extreme impact applications up to 400 kgs.-M (lump size x drop height).
- Impact Energy Absorbers compress up to 75 mm to absorb extreme impact energy to minimize damaging forces and protect the belt.
- Slide-Out System™ allows direct access to service the impact bars.

Stock items (non-shaded) refer to (*) for specific lead time, if not specified, standard 12 week lead time applies.

Non-stock items (shaded) please contact Flexco for dispatch options and lead times.

Product Ordering Information

DRX™ Impact Beds Optional Parts and Tools

Impact Bars with 25 mm UHMW

For impact beds that have heavy abrasive wear on the impact bars.

DESCRIPTION	ORDERING NUMBER	ITEM CODE	WT. KG.
1.2 M Impact Bar with 25 mm UHMW	IB4-1U	76965	7.7
1.5 M Impact Bar with 25 mm UHMW	IB5-1U	76966	9.6

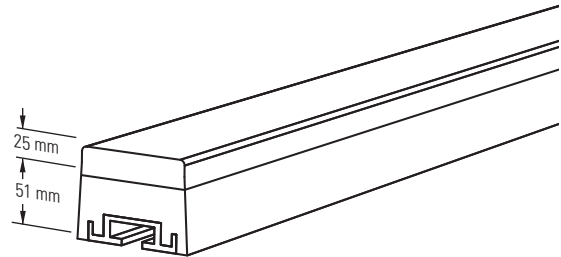

Impact Bar with 25 mm UHMW Cover

Impact Bar Bolt Kit for Other OEM Impact Beds*

13 mm carriage bolts, square washer, flat washer and Nylock nut to mount DRX Impact Bars on other OEM beds that use 13 mm T-bolts.

DESCRIPTION	ORDERING NUMBER	ITEM CODE	WT. KG.
Optional Impact Bar Bolt Kit	OIBBK	76950	0.2

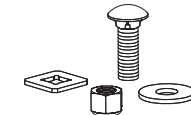

Optional Impact Bar Bolt Kit

*Kit includes 1 ea. bolt, square washer, flat washer and nut.

Impact Bed Handy Wrench

A ratcheting wrench with 2 common socket sizes 19 mm & 24 mm for installation and maintenance of impact beds.

DESCRIPTION	ORDERING NUMBER	ITEM CODE	WT. KG.
Impact Bed Handy Wrench	HW-IMPB	76939	0.7

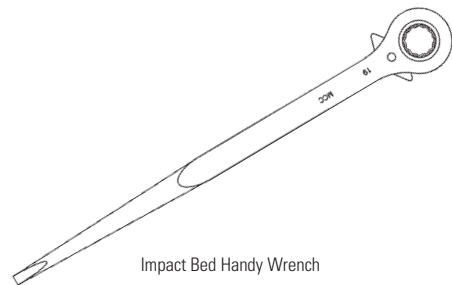

Impact Bed Handy Wrench

 **Stock items** (non-shaded) refer to (*) for specific lead time, if not specified, standard lead time applies.

 **Non-stock items** (shaded) please contact Flexco for dispatch options and lead times.

Product Ordering Information

V-Plough

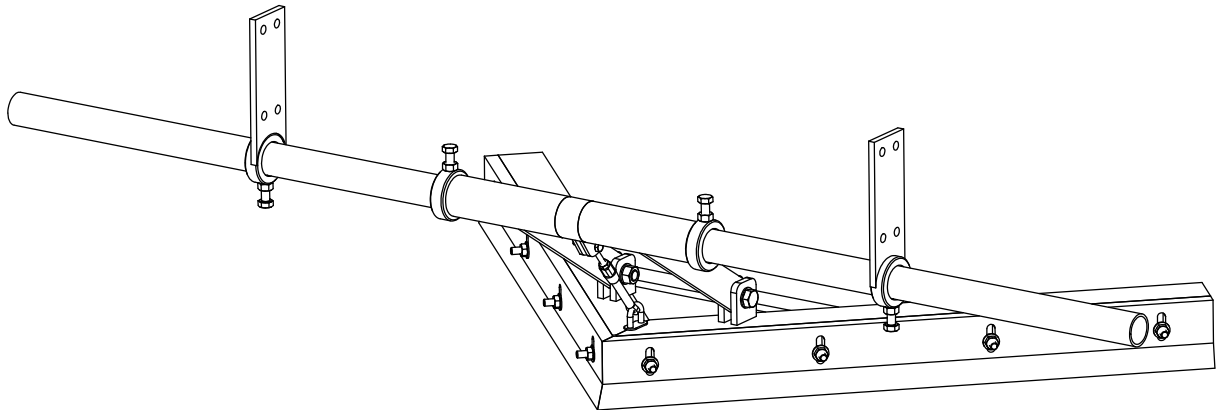

Deflector™ V Plough-Mild Steel

BELT WIDTH mm	ORDERING NUMBER	ITEM CODE	WT. KG.
450	BP450	73102	23
600	BP600	73104	25
750	BP750	73106	26
800	BP800	73107	28
900	BP900	73108	29
1050	BP1050	73110	31
1200	BP1200	73112	38
1400	BP1400	73113	42
1500	BP1500	73114	43
1600	BP1600	73115	44
1800	BP1800	73117	65

Note: Polyurethane Blades are approved for use in underground mines.
For belt widths over 1800 mm contact Flexco®.

Deflector™ V Plough-Stainless Steel

BELT WIDTH mm	ORDERING NUMBER	ITEM CODE	WT. KG.
450	BP450-S/S	76337	24
600	BP600-S/S	76338	25
750	BP750-S/S	76339	27
800	BP800-S/S	76340	29
900	BP900-S/S	76341	30
1050	BP1050-S/S	76342	32
1200	BP1200-S/S	76343	39
1400	BP1400-S/S	76344	44
1500	BP1500-S/S	76345	45
1600	BP1600-S/S	76346	46
1800	BP1800-S/S	76347	67

Note: Polyurethane Blades are approved for use in underground mines.
For belt widths over 1800 mm contact Flexco.

Product Notes:

- Exclusive blade design - 20° slant on leading edge spirals debris off the belt.
- Self-adjusting blade - the blade floats on the belt and self-adjusts as it wears.
- Unique blade adjuster - turnbuckle-type adjuster allows the blade to be accurately positioned to the belt.
- Easy to install - comes fully assembled and can be placed right into position on the conveyor.

Stock items (non-shaded) refer to (*) for specific lead time, if not specified, standard lead time applies.

Non-stock items (shaded) please contact Flexco for dispatch options and lead times.

Replacement Parts List

V-Plough

Replacement Parts		POWDER COATED			STAINLESS STEEL		
DESCRIPTION	BELT WIDTH mm	ORDERING NUMBER	ITEM CODE	WT. KG.	ORDERING NUMBER	ITEM CODE	WT. KG.
PL Pole	450-750	BP450-750-PL	73109	2.8	BP450-750-PL-S/S	A0683	2.7
	800-1050	BP800-1050-PL	73111	3.2	BP800-1050-PL-S/S	A0613	3.2
	1200-1400	BP1200-1400-PL	73118	3.6	BP1200-1400-PL-S/S	A0621	3.6
	1500-1600	BP1500-1600-PL	73119	4.6	BP1500-1600-PL-S/S	A0647	5.0
	1800	BP1800-PL	73121	5.5	BP1800-PL-S/S	A1547	5.9
Frame	450-750	BP450-750MF	73152	6.7	BP450-750MF-S/S MAIN FRAME	A0682	6.7
	800-1050	BP800-1050MF	73153	9.8	BP800-1050MF-S/S MAIN FRAME	A0612	9.8
	1200-1400	BP1200-1400MF	73154	12.6	BP1200-1400MF-S/S MAIN FRAME	A0620	12.6
	1500-1600	BP1500-1600MF	73147	16.0	BP1500-1600MF-S/S MAIN FRAME	A0646	16.0
	1800	BP1800MF	73148	18.3	BP1800MF-S/S MAIN FRAME	A1546	18.3
	2000	BP2000MF	A1996	19.7			
Blades - Polyurethane Pair - 110mm	450	BP450-B	74055	0.9			
	600	BP600-B	73777	0.9			
	750	BP750-B	73778	1.8			
	800	BP800-B	74057	1.8			
	900	BP900-B	73779	1.8			
	1050	BP1050-B	73780	1.8			
	1200	BP1200-B	73781	1.8			
	1400	BP1400-B	73782	2.3			
	1500	BP1500-B	73784	2.7			
	1600	BP1600-B	73784	2.7			
Blades - Polyurethane Pair - 180mm (Heavy- Duty)	750	HBP750-B	A0223	5.2			
	900	HBP900-B	A0224	6.3			
	1050	HBP1050-B	A2237	7.2			
	1200	HBP1200-B	73301	8.4			
	1400	HBP1400-B	73302	9.7			
	1500	HBP1500-B	73303	10.6			
	1600	HBP1600-B	73304	11.6			
	1800	HBP1800-B	73306	13.0			
	2000	HBP2000-B	73307	14.5			
	2200	HBP2200-B	73308	15.9			
	2400	HBP2400-B	73309	16.9			
	2500	HBP2500-B	73311	17.8			
Mounting Bracket		BP-MB	73123	0.5	BP-MB-S/S	A0615	0.5
Shaft Collar		BP-SC	73125	0.5	BP-SC-S/S	A0616	0.5
Linkage Arm		BP-LA	73127	0.9	BP-LA-S/S	A0614	0.9
Turnbuckle Linkage		BP-TL	73141	0.5	BP-TL-S/S	A0617	0.5
Standard Turnbuckle					BP-TB	73738	0.5
Standard U-Bolt					BP-UB	73139	0.5

Lead time: 3 weeks

Stock items (non-shaded) refer to (*) for specific lead time, if not specified, standard lead time applies.

Non-stock items (shaded) please contact Flexco for dispatch options and lead times.

Product Ordering Information

Twin Pole V-Plough



Deflector™ Twin Pole V Plough-Mild Steel UHMPE Blade

BELT WIDTH mm	ORDERING NUMBER	ITEM CODE	WT. KG.
900	HBP900-TP	A2283	93.0
1050	HBP1050-TP	A2284	99.0
1200	HBP1200-TP	A2285	106.0
1400	HBP1400-TP	A2286	115.0
1500	HBP1500-TP	A2287	119.0
1600	HBP1600-TP	A2288	124.0
1800	HBP1800-TP	A2289	133.0
2000	HBP2000-TP	A2290	142.0
2200	HBP2200-TP	A2291	151.0
2400	HBP2400-TP	A2292	162.0
2500	HBP2500-TP	A2293	165.0

Note: Scraping blades are UHMPE material.
Blades are not FRAS approved.
For belt widths over 2500 mm contact Flexco®.
Lead time: 3 weeks

Deflector™ Twin Pole V Plough-Stainless Steel UHMPE Blade

BELT WIDTH mm	ORDERING NUMBER	ITEM CODE	WT. KG.
900	HBP-TP-900 S/S	A2474	94.0
1050	HBP-TP-1050 S/S	A2475	100.0
1200	HBP-TP-1200 S/S	A2476	107.0
1400	HBP-TP-1400 S/S	A2477	116.0
1500	HBP-TP-1500 S/S	A2478	120.0
1600	HBP-TP-1600 S/S	A2479	125.0
1800	HBP-TP-1800 S/S	A2480	134.0
2000	HBP-TP-2000 S/S	A2481	143.0
2200	HBP-TP-2200 S/S	A2482	152.0
2400	HBP-TP-2400 S/S	A2483	163.0
2500	HBP-TP-2500 S/S	A2484	166.0

Note: Scraping blades are UHMPE material.
Blades are not FRAS approved.
For belt widths over 2500 mm contact Flexco.
Lead time: 3 weeks

Stock items (non-shaded) refer to (*) for specific lead time, if not specified, standard lead time applies.

Non-stock items (shaded) please contact Flexco for dispatch options and lead times.

Replacement Parts List

Twin Pole V-Plough

Replacement Parts		POWDER COATED			STAINLESS STEEL		
DESCRIPTION	BELT WIDTH mm	ORDERING NUMBER	ITEM CODE	WT. KG.	ORDERING NUMBER	ITEM CODE	WT. KG.
PL Pole	900	HBP900-PL-TP	A2294	14.0	HBP900-PL-TP-S/S	A2492	15.0
	1050	HBP1050-PL-TP	A2295	15.0	HBP1050-PL-TP-S/S	A2493	16.0
	1200	HBP1200-PL-TP	A2296	16.0	HBP1200-PL-TP-S/S	A2494	17.0
	1400	HBP1400-PL-TP	A2297	18.0	HBP1400-PL-TP-S/S	A2495	19.0
	1500	HBP1500-PL-TP	A2298	20.0	HBP1500-PL-TP-S/S	A2496	21.0
	1600	HBP1600-PL-TP	A2299	21.0	HBP1600-PL-TP-S/S	A2497	22.0
	1800	HBP1800-PL-TP	A2300	22.0	HBP1800-PL-TP-S/S	A2498	23.0
	2000	HBP2000-PL-TP	A2301	24.0	HBP2000-PL-TP-S/S	A2499	25.0
	2200	HBP2200-PL-TP	A2303	26.0	HBP2200-PL-TP-S/S	A2500	27.0
	2400	HBP2400-PL-TP	A2302	28.0	HBP2400-PL-TP-S/S	A2501	29.0
	2500	HBP2500-PL-TP	A2304	29.0	HBP2500-PL-TP-S/S	A2502	30.0
Frame	900	HBP900-MF-TP	A2305	26.0	HBP900-MF-TP-S/S	A2504	27.0
	1050	HBP1050-MF-TP	A2306	28.0	HBP1050-MF-TP-S/S	A2505	29.0
	1200	HBP1200-MF-TP	A2307	30.0	HBP1200-MF-TP-S/S	A2506	31.0
	1400	HBP1400-MF-TP	A2308	33.0	HBP1400-MF-TP-S/S	A2507	34.0
	1500	HBP1500-MF-TP	A2309	34.0	HBP1500-MF-TP-S/S	A2508	35.0
	1600	HBP1600-MF-TP	A2310	35.5	HBP1600-MF-TP-S/S	A2509	36.5
	1800	HBP1800-MF-TP	A2311	38.0	HBP1800-MF-TP-S/S	A2510	39.0
	2000	HBP2000-MF-TP	A2312	41.0	HBP2000-MF-TP-S/S	A2511	42.0
	2200	HBP2200-MF-TP	A2314	44.0	HBP2200-MF-TP-S/S	A2512	45.0
	2400	HBP2400-MF-TP	A2313	52.0	HBP2400-MF-TP-S/S	A2513	53.0
	2500	HBP2500-MF-TP	A2315	54.0	HBP2500-MF-TP-S/S	A2514	55.0
Blades	900	HBP900-B-TP	A2316	4.5			
	1050	HBP1050-B-TP	A2317	5.0			
	1200	HBP1200-B-TP	A2318	5.5			
	1400	HBP1400-B-TP	A2319	6.3			
	1500	HBP1500-B-TP	A2320	7.0			
	1600	HBP1600-B-TP	A2321	7.5			
	1800	HBP1800-B-TP	A2322	8.2			
	2000	HBP2000-B-TP	A2323	9.0			
	2200	HBP2200-B-TP	A2325	9.8			
	2400	HBP2400-B-TP	A2324	10.7			
2500	HBP2500-B-TP	A2326	11.2				
Linkage Arm	900-2500	HBP-LA-TP	A2330	5.0	HBP-LA-TP-S/S	A2515	5.0
Mounting Bracket	900-2500	HBP-MB-TP	73922	2.1	HBP-MB-TP-S/S	A1155	2.1
Shaft Collar	900-2500	HBP-SC-TP	74490	0.7	HBP-SC-TP-S/S	A2189	0.7

Lead time: 3 weeks

Stock items (non-shaded) refer to (*) for specific lead time, if not specified, standard lead time applies.

Non-stock items (shaded) please contact Flexco for dispatch options and lead times.

Product Ordering Information

HD® Floating V-Plough



HD® Floating V Plough-Mild Steel UHMPE Blade

BELT WIDTH mm	ORDERING NUMBER	ITEM CODE	WT. KG.
900	FBP900-TP	61750	133
1050	FBP1050-TP	61751	137
1200	FBP1200-TP	61752	163
1400	FBP1400-TP	61753	167
1500	FBP1500-TP	61754	189
1600	FBP1600-TP	61755	192
1800	FBP1800-TP	61756	218
2000	FBP2000-TP	61757	224
2200	FBP2200-TP	61758	256
2400	FBP2400-TP	61759	261
2500	FBP2500-TP	61760	284
2600	FBP2600-TP	61761	287

Note: Scraping blades are UHMPE material. Blades are not FRAS approved. For belt widths over 2600 mm contact Flexco®. Lead time: 3 weeks

HD Floating V Plough Stainless Steel UHMPE Blade

BELT WIDTH mm	ORDERING NUMBER	ITEM CODE	WT. KG.
900	FBP900-TP S/S	61765	135
1050	FBP1050-TP S/S	61766	141
1200	FBP1200-TP S/S	61767	167
1400	FBP1400-TP S/S	61768	171
1500	FBP1500-TP S/S	61769	194
1600	FBP1600-TP S/S	61770	197
1800	FBP1800-TP S/S	61771	224
2000	FBP2000-TP S/S	61772	230
2200	FBP2200-TP S/S	61773	263
2400	FBP2400-TP S/S	61774	268
2500	FBP2500-TP S/S	61775	291
2600	FBP2600-TP S/S	61776	294

Note: Scraping blades are UHMPE material. Blades are not FRAS approved. For belt widths over 2600 mm contact Flexco. Lead time: 3 weeks

Replacement Blades

UHMPE - pair

BELT WIDTH mm	ORDERING NUMBER	ITEM CODE	WT. KG.
900	FBP900-B	61780	11.0
1050	FBP1050-B	61781	12.6
1200	FBP1200-B	61782	14.3
1400	FBP1400-B	61783	16.4
1500	FBP1500-B	61784	17.5
1600	FBP1600-B	61785	18.5
1800	FBP1800-B	61786	20.5
2000	FBP2000-B	61787	22.6
2200	FBP2200-B	61788	24.6
2400	FBP2400-B	61789	26.7
2500	FBP2500-B	61790	28.3
2600	FBP2600-B	61791	29.8

Lead time: 3 weeks

Product Notes:

- Cleans the inside/clean side of the return belt.
- Eliminates conveyor damage and belt mistracking caused by debris lodging in the tail pulley or take-up.
- Floating design self-adjusts as blade wears, eliminating the need for manual adjustment.
- Available in a range of sizes for multiple belt widths.
- Removes carryback on both sides of the conveyor
- UHMWPE blades provide long life and easy change-out.

Stock items (non-shaded) refer to (*) for specific lead time, if not specified, standard lead time applies.

Non-stock items (shaded) please contact Flexco for dispatch options and lead times.

Replacement Parts List

HD® Floating V-Plough

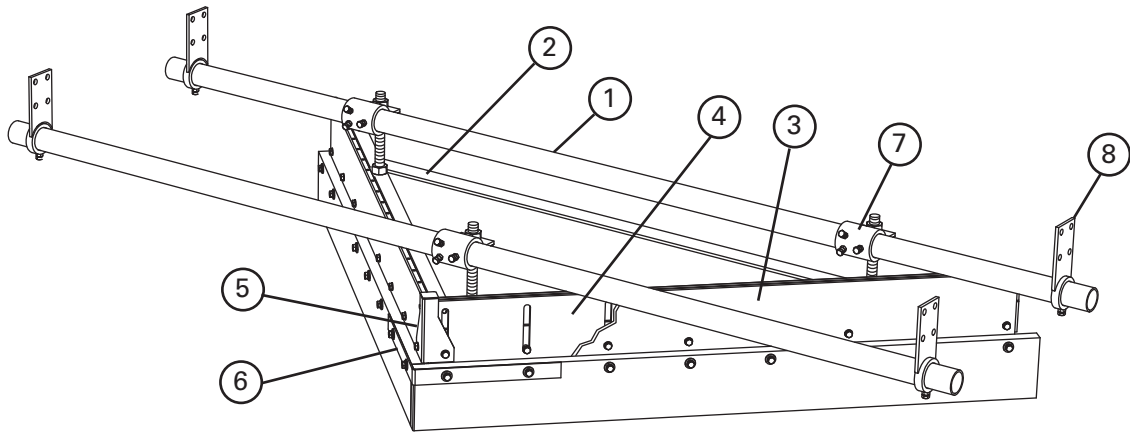

Replacement Parts

REF	DESCRIPTION	BELT WIDTH mm	MILD STEEL			STAINLESS STEEL		
			ORDERING NUMBER	ITEM CODE	WT. KG.	ORDERING NUMBER	ITEM CODE	WT. KG.
1	Pole	900	HBP900-PL-TP	A2294		HBP900-PL-TP-S/S	A2492	
		1050	HBP1050-PL-TP	A2295		HBP1050-PL-TP-S/S	A2493	
		1200	HBP1200-PL-TP	A2296		HBP1200-PL-TP-S/S	A2494	
		1400	HBP1400-PL-TP	A2297		HBP1400-PL-TP-S/S	A2495	
		1500	HBP1500-PL-TP	A2298		HBP1500-PL-TP-S/S	A2496	
		1600	HBP1600-PL-TP	A2299		HBP1600-PL-TP-S/S	A2497	
		1800	HBP1800-PL-TP	A2300		HBP1800-PL-TP-S/S	A2498	
		2000	HBP2000-PL-TP	A2301		HBP2000-PL-TP-S/S	A2499	
		2200	HBP2200-PL-TP	A2303		HBP2200-PL-TP-S/S	A2500	
		2400	HBP2400-PL-TP	A2302		HBP2400-PL-TP-S/S	A2501	
		2500	HBP2500-PL-TP	A2304		HBP2500-PL-TP-S/S	A2502	
		2600	HBP2600-PL-TP	A0151		HBP2600-PL-TP-S/S	61877	
2	Frame	900-1050	FBP900-1050-MF	61795		FBP900-1050-MF-S/S	61803	
		1200-1400	FBP1200-1400-MF	61796		FBP1200-1400-MF-S/S	61804	
		1500-1600	FBP1500-1600-MF	61797		FBP1500-1600-MF-S/S	61805	
		1800-2000	FBP1800-2000-MF	61798		FBP1800-2000-MF-S/S	61806	
		2200-2400	FBP2200-2400-MF	61799		FBP2200-2400-MF-S/S	61807	
		2500-2600	FBP2500-2600-MF	61800		FBP2500-2600-MF-S/S	61808	
3	Protection Plate Kit	900-1050	FBP900-1050-PP	61890		FBP900-1050-PP-S/S	61898	
		1200-1400	FBP1200-1400-PP	61891		FBP1200-1400-PP-S/S	61899	
		1500-1600	FBP1500-1600-PP	61892		FBP1500-1600-PP-S/S	61900	
		1800-2000	FBP1800-2000-PP	61893		FBP1800-2000-PP-S/S	61901	
		2200-2400	FBP2200-2400-PP	61894		FBP2200-2400-PP-S/S	61902	
4	Slotted Plate Kit	2500-2600	FBP2500-2600-PP	61895		FBP2500-2600-PP-S/S	61903	
		900-1050	FBP900-1050-SP	61906		FBP900-1050-SP-S/S	61914	
		1200-1400	FBP1200-1400-SP	61907		FBP1200-1400-SP-S/S	61915	
		1500-1600	FBP1500-1600-SP	61908		FBP1500-1600-SP-S/S	61916	
		1800-2000	FBP1800-2000-SP	61909		FBP1800-2000-SP-S/S	61917	
		2200-2400	FBP2200-2400-SP	61910		FBP2200-2400-SP-S/S	61918	
2500-2600	FBP2500-2600-SP	61911		FBP2500-2600-SP-S/S	61919			
5	Nose Protection	All	FBP-NP	61875		FBP-NP-S/S	61876	
6	Faceplate	All	FBP-FP	61888		FBP-FP-S/S	61889	
7	Linkage Mount Kit	All	FBP-LM	61882		FBP-LM-S/S	61883	
8	Mounting Bracket	All	HBP-MB-TP	73922		HBP-MB-TP-S/S	A1155	

Lead time: 3 weeks

Stock items (non-shaded) refer to (*) for specific lead time, if not specified, standard lead time applies.

Non-stock items (shaded) please contact Flexco for dispatch options and lead times.

Product Ordering Information

Diagonal Plough

Diagonal Ploughs - Mild Steel*

BELT WIDTH mm	ORDERING NUMBER	ITEM CODE	WT. KG.
450-750	CBD-S	76442	20.0
900-1050	CBD-M	76443	25.0
1200-1500	CBD-L	76444	32.0
1600-1800	CBD-XL	76445	43.0
2000-2400	CBD-XXL	64787	54.0

*Use next larger size for Belt Widths between ranges.



Diagonal Plough* - Stainless Steel*

BELT WIDTH mm	ORDERING NUMBER	ITEM CODE	WT. KG.
450-750	CBD-S-S/S	64178	20.0
900-1050	CBD-M-S/S	A1854	25.0
1200-1500	CBD-L-S/S	A1856	32.0
1600-1800	CBD-XL-S/S	76318	43.0
2000-2400	CBD-XXL-S/S	63554	54.0

*Use next larger size for Belt Widths between ranges.

Replacement Blade Kits-Polyurethane Blades

BELT WIDTH mm	ORDERING NUMBER	ITEM CODE	WT. KG.
450-750	DBK-S	76446	2.0
900-1050	DBK-M	76447	3.0
1200-1500	DBK-L	76448	4.0
1600-2000	DBK-XL	76449	5.0

Kit includes blade and replacement blade bolts.
Diagonal Plough requires 1 blade; Reversing Plough requires 2 blades.

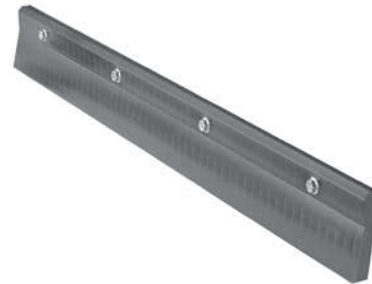

Deflector™ Reversible Plough with Polyurethane Blades-Mild Steel

BELT WIDTH mm	ORDERING NUMBER	ITEM CODE	WT. KG.
450-750	CBR-S	72483	40.0
900-1050	CBR-M	72484	48.0
1200-1500	CBR-L	72485	60.0
1600-2000	CBR-XL	72486	80.0

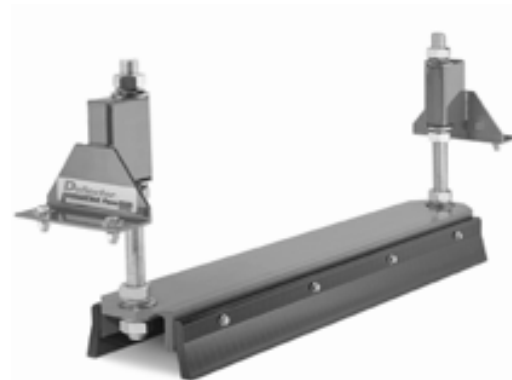

Product Notes:

- A belt cleaner for the tail pulley. Prevents damage to the belt, pulley, lagging, and belt splice.
- Keeps fugitive materials off the inside of the belt and out of the tail pulley.
- Installed at a 45° angle across the belt to discharge material to one predetermined side.
- The blade is installed in a fixed position, eliminating any bouncing problems.
- Exclusive 20° angled blade quickly spirals material off the belt.

 Stock items (non-shaded) refer to (*) for specific lead time, if not specified, standard lead time applies.

 Non-stock items (shaded) please contact Flexco for dispatch options and lead times.

Product Ordering Information & Replacement Parts

Diagonal Plough
HD® Spring Tensioned

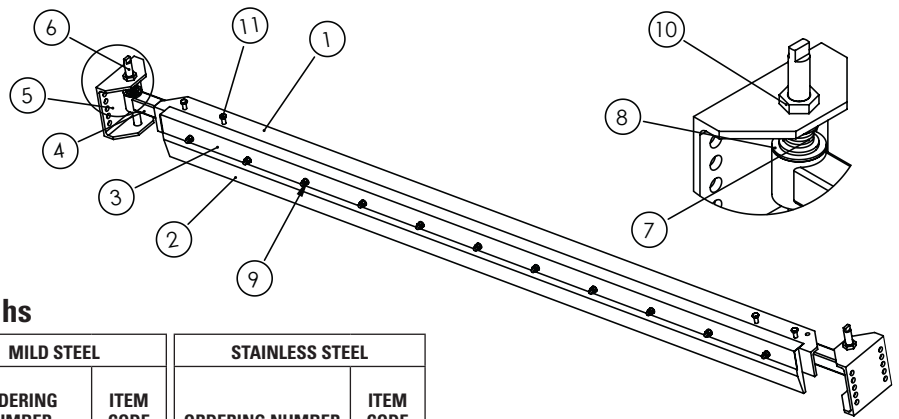

HD® Spring Tensioned Diagonal Ploughs

DESCRIPTION	BELT WIDTH mm	MILD STEEL		STAINLESS STEEL	
		ORDERING NUMBER	ITEM CODE	ORDERING NUMBER	ITEM CODE
Heavy-Duty Spring Tensioned Diagonal Plough	900-1050	CBD-ST-M	61077	CBD-ST-M-S/S	61079
	1200-1500	CBD-ST-L	61050	CBD-ST-L-S/S	61080
	1600-1800	CBD-ST-XL	61051	CBD-ST-XL-S/S	A2138
	2000-2400	CBD-ST-XXL	63747	CBD-ST-XXL-S/S	63748
Heavy-Duty Spring Tensioned Diagonal Plough with Polyurethane Blade	900-1050	CBD-ST-M-P	64772	CBD-ST-M-P-S/S	64623
	1200-1500	CBD-ST-L-P	64773	CBD-ST-L-P-S/S	64624
	1600-1800	CBD-ST-XL-P	64774	CBD-ST-XL-P-S/S	64625
	2000-2400	CBD-ST-XXL-P	64775	CBD-ST-XXL-P-S/S	64626
Heavy-Duty Spring Tensioned Diagonal Plough with Polyurethane Blade and Shield	900-1050	CBD-ST-M-PSS	64776	CBD-ST-M-PS-S/S	64780
	1200-1500	CBD-ST-L-PS	64777	CBD-ST-L-PS-S/S	64781
	1600-1800	CBD-ST-XL-PS	64778	CBD-ST-XL-PS-S/S	64782
	2000-2400	CBD-ST-XXL-PS	64779	CBD-ST-XXL-PS-S/S	64783

Lead time: 3 weeks

Replacement Parts

REF	DESCRIPTION	BELT WIDTH mm	BLADE WIDTH mm	MILD STEEL		STAINLESS STEEL	
				ORDERING NUMBER	ITEM CODE	ORDERING NUMBER	ITEM CODE
1	Diagonal Plough Main Frame	900-1050	N/A	CBD-ST-M-MF	61105	CBD-ST-M-MF-S/S	61108
		1200-1500	N/A	CBD-ST-L-MF	61106	CBD-ST-L-MF-S/S	61109
		1600-1800	N/A	CBD-ST-XL-MF	61107	CBD-ST-XL-MF-S/S	61110
		2000-2400	N/A	CBD-ST-XXL-MF	63749	CBD-ST-XXL-MF-S/S	63750
2	Standard Blade (FRAS)	900-1050	1750	CBD-ST-FR-B	61111		
		1200-1500	2250	CBD-ST-L-FR-B	A2218		
		1600-1800	2750	CBD-ST-XL-FR-B	A1784		
		2000-2400	3250	CBD-ST-XXL-FR-B	63752		
	Polyurethane Blade	900-1050	1750	CBD-ST-B	64620		
		1200-1500	2250	CBD-ST-L-B	64621		
		1600-1800	2750	CBD-ST-XL-B	64482		
		2000-2400	3250	CBD-ST-XXL-B	64622		
3	Stainless Steel Face Plate	900-1050	N/A	CBD-ST-M-FP	61112		
		1200-1500	N/A	CBD-ST-L-FP	61113		
		1600-1800	N/A	CBD-ST-XL-FP	61114		
		2000-2400	N/A	CBD-ST-XXL-FP	63751		
-	Diagonal Plough Shields	900-1050	N/A	CBD-ST-M-S	64784		
		1200-1500	N/A	CBD-ST-L-S	64785		
		1600-1800	N/A	CBD-ST-XL-S	63024		
		2000-2400	N/A	CBD-ST-XXL-S	63791		
4	Adjusting Arm	N/A		CBD-ST-AA	61096		
5	Mounting Channel	N/A		CBD-ST-MC	B0092		
6	Threaded Bar	N/A		CBD-ST-TB-S/S	A2629		
7	Compression Spring	N/A		CBD-ST-CS-S/S	A2215		
8	Poly Bush	N/A		CBD-ST-PB	A2449		
	Bush with Brass Insert			CBD-ST-BB	64310		
9	M12 NYLOC, S/S 316 nut & flat washer	N/A		N/A	N/A		
10	Fasteners kit (M24 half nuts & flat washers - SS304) Qty: 4 each	N/A		CBD-ST-HN-S/S	61100		
11	M12 X40 Hex bolt & nuts (SS316) Qty: 8 each	N/A		N/A	N/A		

Lead time: 3 weeks

Product Ordering Information

Belt Positioners with CoreTech™ Rollers

SIZE	BELT WIDTH (MIN-MAX) mm	POSITIONER WIDTH (MIN-MAX) mm	ORDERING NUMBER	ITEM CODE	WT. KG.
Small	450-600	600-850	PSR-S	74558	29.2
Medium	750-1200	850-1400	PSR-M	74559	34.5
Large	1350-1800	1400-2075	PSR-L	74560	44.3
Extra Large	1800-2400	1800-3000	PSR-XL	74561	82.1

Note:

- Use next larger size for belt widths between ranges.
- Idler rollers on sizes:
 - S-M-L are 127 mm diameter
 - X are 152 mm diameter
- Finish: All steel parts are powder coated. All nuts and set screws are metric in 300 series Stainless Steel.
- This product is also available in Stainless Steel. Please contact Flexco® for pricing.



Belt Positioners with Steel Rollers

SIZE	BELT WIDTH (MIN-MAX) mm	POSITIONER WIDTH (MIN-MAX) mm	ORDERING NUMBER	ITEM CODE	WT. KG.
Small	450-600	600-850	PSR-S-F	62350	31.7
Medium	750-1200	850-1400	PSR-M-F	62351	38.5
Large	1350-1800	1400-2075	PSR-L-F	62352	49.8
Extra Large	1800-2400	1800-3000	PSR-XL-F	62353	90.7

Product Notes:

- The Positioner should be centered between two standard return rollers. For general applications-standard belts up to 1800 mm: position the unit no closer than 900 mm to a return roller and no farther than 1.8 meters.
- Works on the return side of the conveyor using simple angled rollers mounted in a fixed position to quickly and continuously funnel the belt into the correct path.
- A “quick fix” solution for belts that consistently wander to one side.
- Typically installed before the tail pulley to keep the belt centred at the critical loading point. Centre loading is the key to solving many top side tracking problems.
- Idler rollers make smooth contact with the return belt’s bottom cover, eliminating excessive wear and damage to the belt’s edges.
- Has no pivoting mechanism to freeze up and cause the unit to stop working.
- Once installed, no further adjustment is required.

Stock items (non-shaded) refer to (*) for specific lead time, if not specified, standard lead time applies.

Non-stock items (shaded) please contact Flexco for dispatch options and lead times.

Replacement Parts List

Belt Positioner™

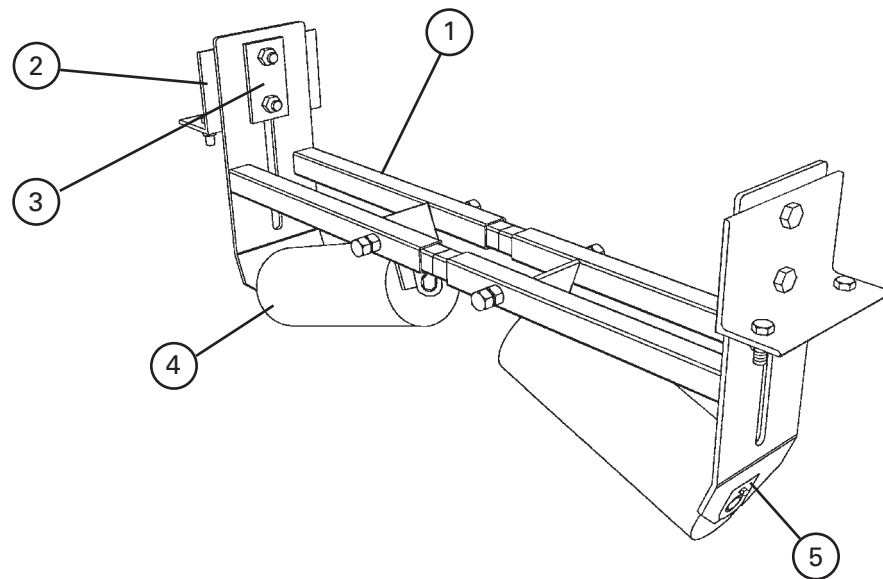

Replacement Parts

REF	DESCRIPTION	BELT WIDTH (MIN-MAX) mm	ORDERING NUMBER	ITEM CODE	WT. KG.
1	Small Frame Kit* (1 ea.)	450-650	RBPFK-S	73946	5.7
	Medium Frame Kit* (1 ea.)	750-1200	RBPFK-M	73947	6.5
	Large Frame Kit* (1ea.)	1350-1600	RBPFK-L	73948	8.8
	Extra Large Frame Kit* (1 ea.)	1800-2400	RBPFK-XL	73949	13.0
2	Mounting Bracket Kit* (1 ea.)		RBPMBK	74327	2.7
3	Clamp Plate	450-2400	RBPCP	73162	0.5

* Hardware included

Replacement Rollers

REF	DESCRIPTION	ORDERING NUMBER	ITEM CODE	WT. KG.
4	Small Steel Roller	RBPSR-S	74562	5.5
	Medium Steel Roller	RBPSR-M	74563	7.5
	Large Steel Roller	RBPSR-L	74564	10.5
	Extra Large Steel Roller	RBPSR-XL	74565	16.6
	Small CoreTech™ Roller	RBPSR-S-CCT	28250	3
	Medium CoreTech Roller	RBPSR-M-CCT	29135	3.5
	Large CoreTech Roller	RBPSR-L-CCT	28253	5
	Extra Large CoreTech Roller	RBPSR-XL-CCT	28254	8
5	Roller Retainer Kit*	RBPRET	A1622	0.2

Positioners come standard with Steel rollers.

 **Stock items** (non-shaded) refer to (*) for specific lead time, if not specified, standard lead time applies.

 **Non-stock items** (shaded) please contact Flexco for dispatch options and lead times.

Product Ordering Information

PTEZ™
Belt Trainer

PTEZ™ Belt Trainer

BELT WIDTH		ORDERING NUMBER	ITEM CODE	WT. Kg.
mm	in.			
450	18	PTEZ-450	90265	54.4
600	24	PTEZ-600	90266	58.9
750	30	PTEZ-750	90267	63.5
900	36	PTEZ-900	90268	68
1050	42	PTEZ-1050	90269	72.6
1200	48	PTEZ-1200	90270	77.1

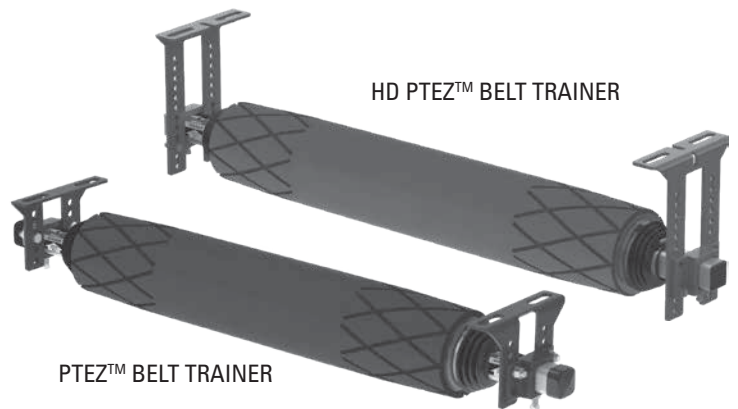

HD PTEZ™ Belt Trainer

BELT WIDTH		ORDERING NUMBER	ITEM CODE	WT. Kg.
mm	in.			
1050	42	PTEZHD-1050	90616	103.6
1200	48	PTEZHD-1200	90617	114.5
1350	54	PTEZHD-1350	90618	125.9
1400	56	PTEZHD-1500	90795	129.5
1500	60	PTEZHD-1500	90619	136.8
1600	64	PTEZHD-1600	90796	144.1
1800	72	PTEZHD-1800	90620	158.6
2000	80	PTEZHD-2000	90797	173.6
2100	84	PTEZHD-2100	90621	180.9

Product Notes:

- Simple adjustable mounting brackets ensure quick and accurate installation.
- Urethane roller cover ensures long-lasting performance.
- Works in multiple applications, yet economical. Single-direction and reversing belts. Wet or dry conditions. Belts with edge damage or wear. Belts mistracking to one or both sides.
- Easy ordering and installation. Enhanced to meet instant demands for training solutions, the PTEZ is available on a one-working-day lead time. The simple brackets and component construction also ensure a quick and easy installation.
- Uses tapered and patterned roller to activate the trainer movement. Pivot influences direction while Tilt increases the tension on the mistracked side—the result is two forces quickly moving the belt back to center.
- Works with mechanically fastened or vulcanized belts.

Replacement Parts List

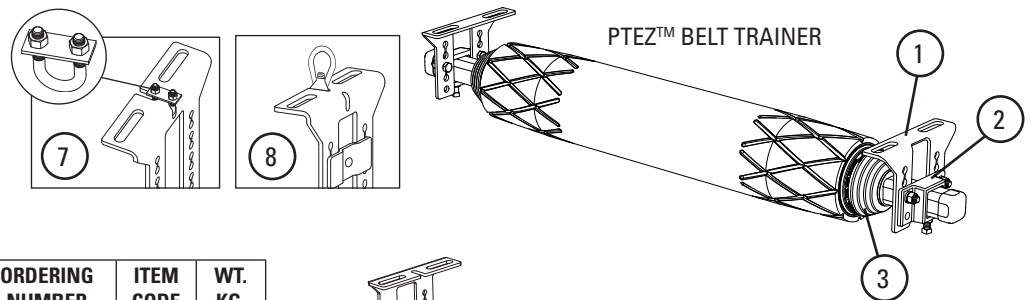

PTEZ™ Replacement Parts

REF	DESCRIPTION	ORDERING NUMBER	ITEM CODE	WT. KG.
1	PTEZ Mounting Bracket (2 ea.)	PTEZMB	90351	3.6
2	PTEZ Main Shaft Bracket (2 ea.)	PTEZPB	90352	2.7
3	PTEZ Main Shaft Dust Cover (2 ea.)	PTEZDC	90353	0.5
4	PTEZ HD Mount Bracket Kit (2 ea.)	PTEZHDB-2	90803	8.6
5	PTEZ HD Pole Bracket Kit (2 ea.)	PTEZHDPB-2	90804	3.2
6	PTEZ HD Dust Cover Kit (2 ea.)	PTEZHDDC-2	90805	0.5
7	PTEZ HD Wire Rope Bolt Kit (2 ea.)	PTEZHDWRB-2	90806	0.5
8	PTEZ HD J Bolt Bracket Kit (2 ea.)	PTEZHDBB-2	90807	0.9

*Bracket set for 1 roller

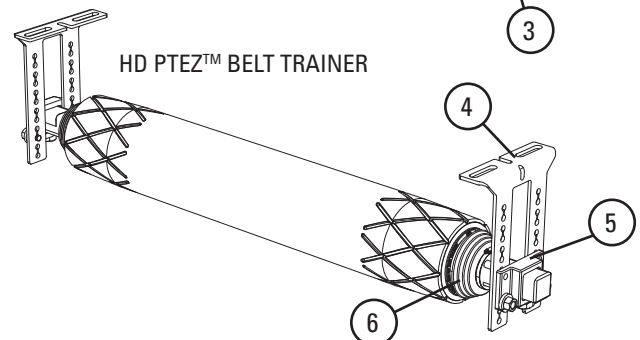

Specifications & Guidelines

PTEZ™
Belt Trainer

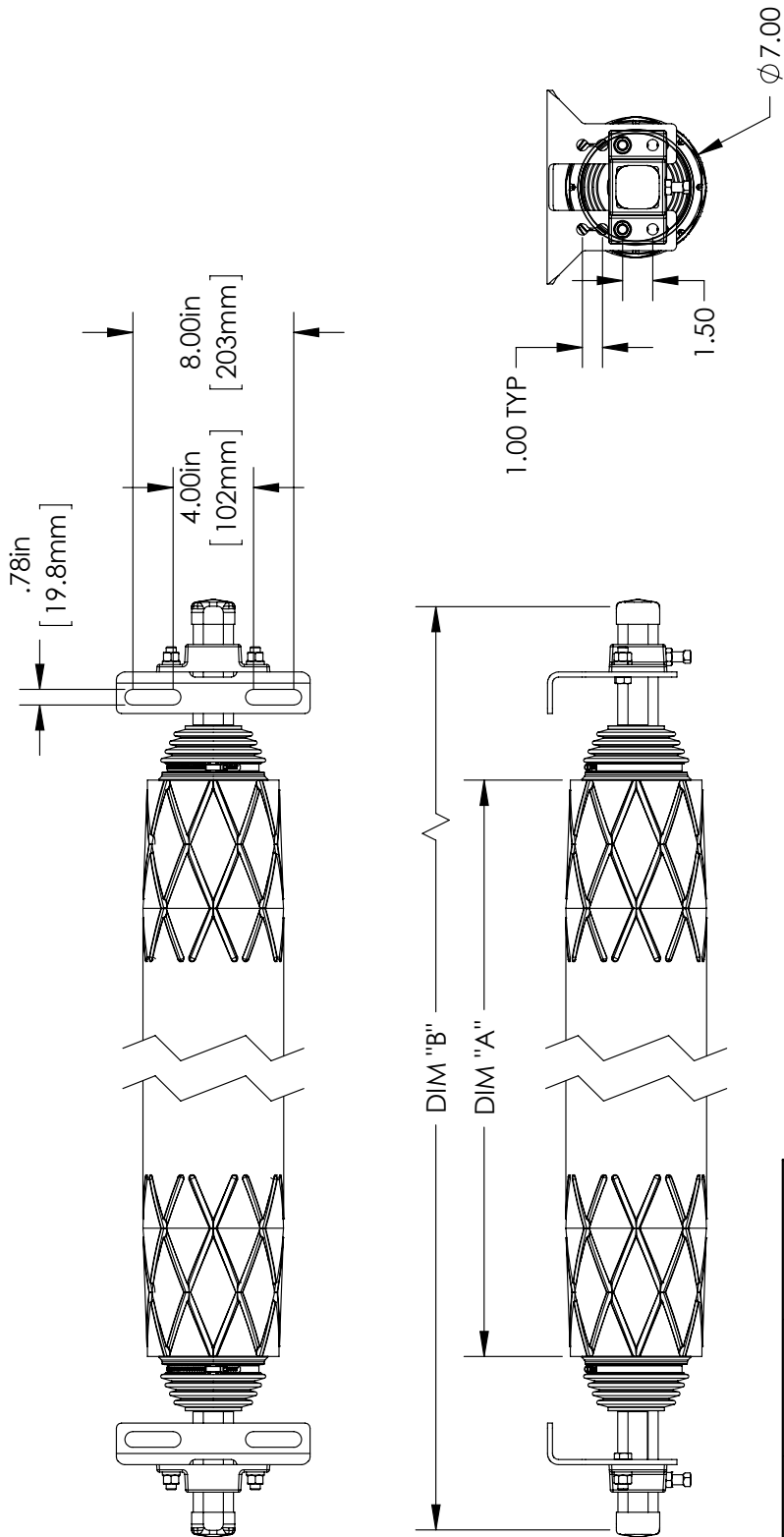

PART NUMBER	BELT WIDTH	DIM "A"	DIM "B"
90265	18"	18.75" [476mm]	36" [914mm]
90266	24"	24.75" [629mm]	42" [1067mm]
90267	30"	30.75" [781mm]	48" [1219mm]
90268	36"	36.75" [933mm]	54" [1372mm]
90269	42"	42.75" [1086mm]	60" [1524mm]
90270	48"	48.75" [1238mm]	66" [1676mm]

Specifications & Guidelines

HD PTEZ™
Belt Trainer

SPECIFICATIONS					
BELT WIDTH (in)	ROLL LENGTH 'A' (in)	SHAFT LENGTH 'B' (in)	ORDER NUMBER	ITEM CODE	
42	42.75	60	PTEZ HD-42	90616	
48	48.75	66	PTEZ HD-48	90617	
54	54.75	72	PTEZ HD-54	90618	
56	56.75	74	PTEZ HD-56	90795	
60	60.75	78	PTEZ HD-60	90619	
64	64.75	82	PTEZ HD-64	90796	
72	72.75	90	PTEZ HD-72	90620	
80	80.75	98	PTEZ HD-80	90797	
84	84.75	102	PTEZ HD-84	90621	

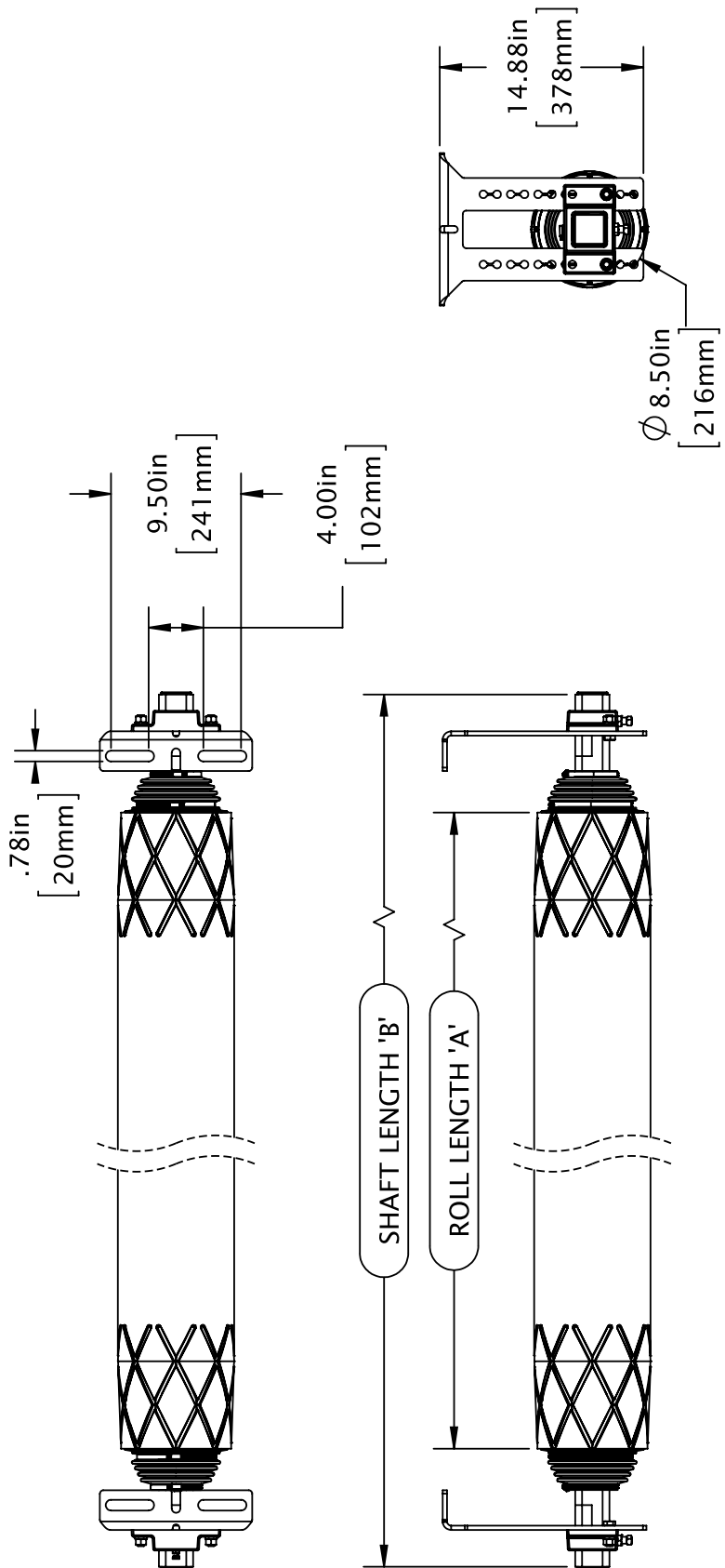

Specifications & Guidelines

HD PTEZ™ Underground Belt Trainer

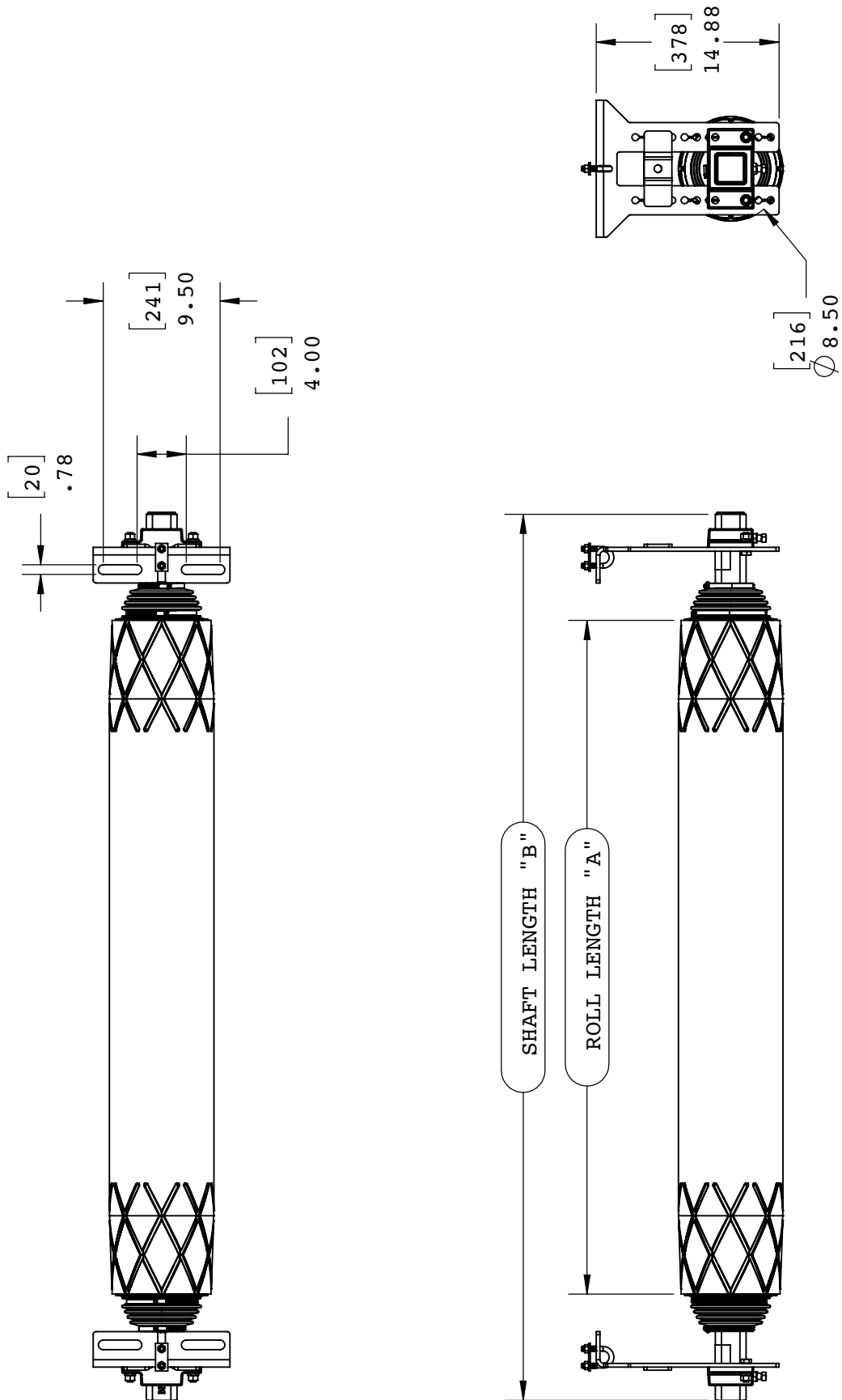

Product Ordering Information

PT Smart™
Belt Trainer



PT Smart Standard
Belt Trainer
(Roller Included)

PT Smart™ Belt Trainer

BELT TRAINER COMPLETE			REPLACEMENT ROLLERS	
BELT WIDTH MM	ORDERING NUMBER	ITEM CODE	ORDERING NUMBER	ITEM CODE
450	PTS-18R	77664	PTS-RR21	77680
600	PTS-24R	77665	PTS-RR27	77681
750	PTS-30R	77666	PTS-RR33	77682
900	PTS-36R	77667	PTS-RR39	77683
1050	PTS-42R	77668	PTS-RR45	77684
1200	PTS-48R	77669	PTS-RR51	77685
1350	PTS-54R	77670	PTS-RR57	77686
1500	PTS-60R	77671	PTS-RR63	77687
1800	PTS-72R	77672	PTS-RR75	77689

Lead time: 1 week

Selection Guidelines

CONVEYOR CRITERIA	PT SMART™
Top side mistracking	NO
Return side mistracking	YES
Belt mistracking to one side	EXCELLENT
Belt mistracking to both sides	EXCELLENT
Inconsistent tracking problem	EXCELLENT
Belt is cupped (heavy)	GOOD
Belt has low running tension	EXCELLENT
Belt has medium running tension	EXCELLENT
Belt has high running tension	GOOD
Approx. "upstream" effect*	6 M
Approx. "downstream" effect*	36 - 45 M

Specifications:

- Maximum Belt Speed5M/sec
- Temperature Rating-40°C to 71°C
- Belt DirectionOne way
- Available for Belt Widths450 to 1800 mm
- Application Range.....Medium-duty belts up to 1600 PIW max tension.
Belt width + 75 mm idler.
Belt thickness 25 mm maximum.

Stock items (non-shaded) refer to (*) for specific lead time, if not specified, standard lead time applies.

Non-stock items (shaded) please contact Flexco for dispatch options and lead times.

Replacement Parts List

**PT Smart™
Belt Trainer**

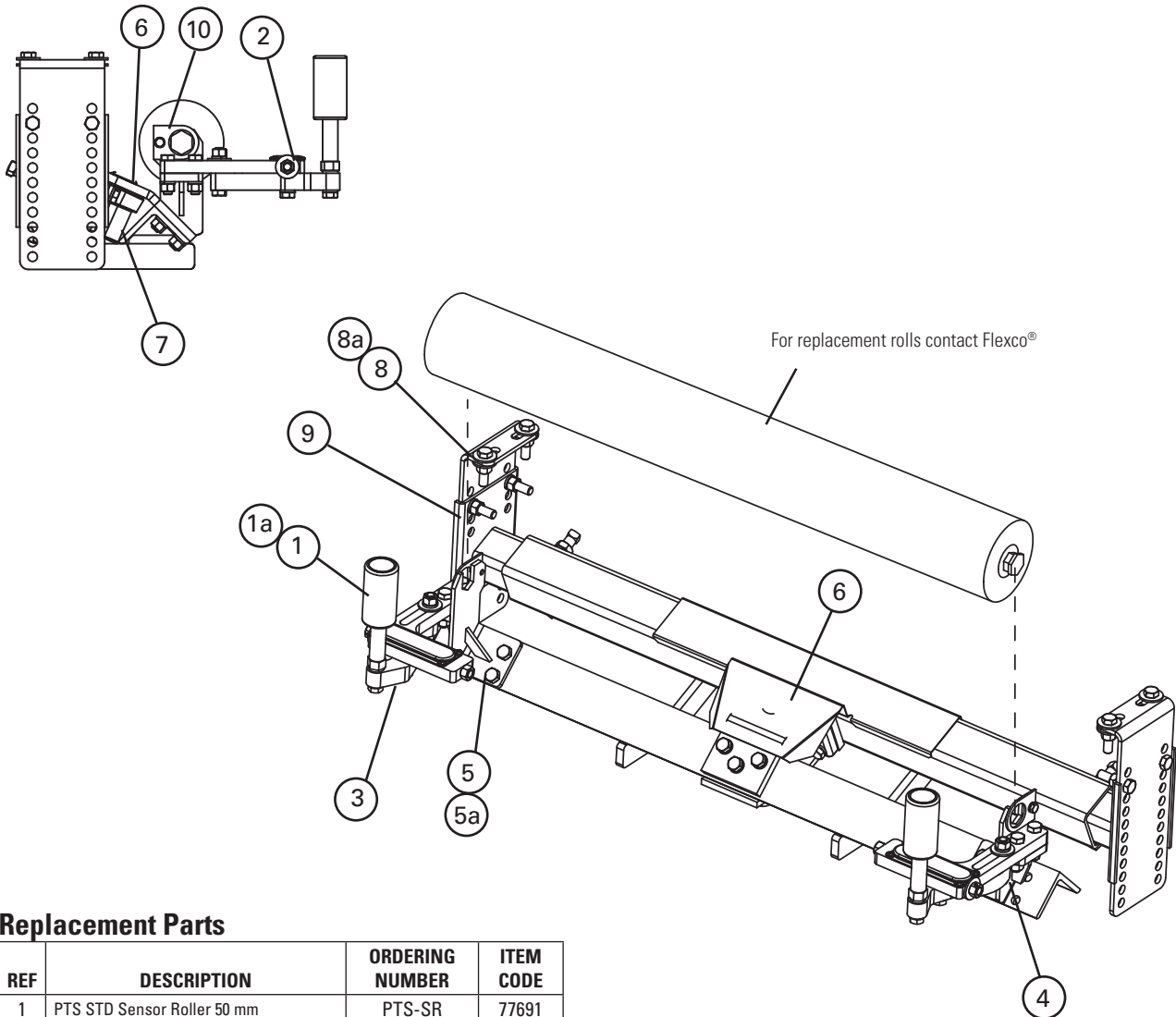

Replacement Parts

REF	DESCRIPTION	ORDERING NUMBER	ITEM CODE
1	PTS STD Sensor Roller 50 mm	PTS-SR	77691
1a	PTS HD® Sensor Roller 75 mm	PTS-HDSR	77692
2	PTS Adjusting Bolt Kit	PTS-ABK	77693
3	PTS Sensor Arm Kit (incl. 1 ea.)	PTS-SAK	77694
4	PTS RH Sensor Adjuster Assy	PTS-RHSAA	77755
	PTS LH Sensor Adjuster Assy	PTS-LHSAA	77756
5	PTS Idler Bracket Kit (incl. L & R)	PTS-IBK	77696
5a	PTS HD Idler Bracket Kit (incl. L & R)	PTS-HIBK	77697
6	PTS Pivot Shield	PTS-PS	77698
7	PTS Pivot Assy (Axle and housing)	PTS-PA	77699
8	PTS Mounting Bracket Kit	PTS-MBK	77700
8a	PTS Mounting Bracket Kit U/G	PTS-MBKUG	77701
9	PTS Extending Bracket Kit (incl. L & R)	PTS-EBK	77702
10	Roller Retainer Kit	RBPRET	73163

*Hardware included

Stock items (non-shaded) refer to (*) for specific lead time, if not specified, standard lead time applies.

Non-stock items (shaded) please contact Flexco for dispatch options and lead times.

Specifications & Guidelines

PT Smart™
Belt Trainer

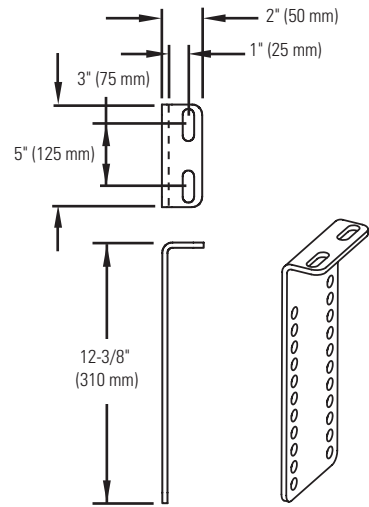
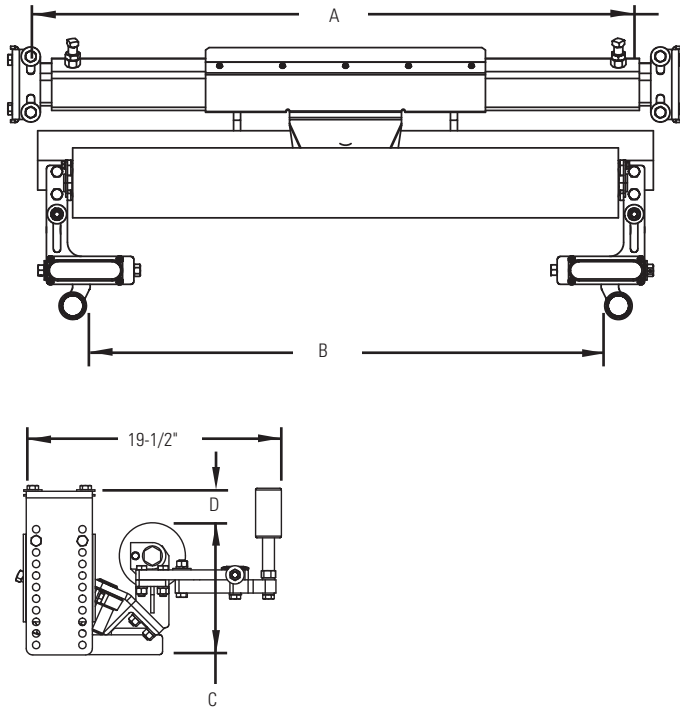

PT Smart™ Standard

BELT WIDTH mm	ITEM CODE	A	B	C	D (VERTICAL ADJUSTMENT)
450	77664	575-875mm	250-575 mm	250 mm	0-250 mm
600	77665	725-1025mm	400-725 mm		
750	77666	875-1175mm	550-875 mm		
900	77667	1025-1325mm	700-1025 mm		
1050	77668	1175-1475mm	825-1175 mm		
1200	77669	1325-1625mm	1000-1325 mm		
1350	77670	1475-1775mm	1150-1475 mm		
1500	77671	1625-1925mm	1300-1625 mm		
1800	77672	1925-2225mm	1600-1925 mm		

Product Ordering Information

PT Pro Belt Trainer



PT Pro Belt Trainer

Version	Belt Trainer Complete				
	Belt Width		Ordering Number	Item Code	Wt. Kg.
	mm	in.			
Standard	450	18	PTP18R	79267	119.8
	600	24	PTP24R	79268	129.5
	750	30	PTP30R	79269	136.8
	900	36	PTP36R	79270	150.1
	1050	42	PTP42R	79271	158.1
	1200	48	PTP48R	79272	166.1
	1350	54	PTP54R	79273	174.1
	1500	60	PTP60R	79274	182.1
	1800	72	PTP72R	79275	198.0
Heavy-Duty	1200	48	PTPHD48R	79276	215.9
	1350	54	PTPHD54R	79277	227.6
	1500	60	PTPHD60R	79278	239.4
	1800	72	PTPHD72R	79279	262.7
	2100	84	PTPHD84R	79280	301.5
	2400	96	PTPHD96R	79281	319.8
Version	Replacement Rollers				
	Belt Width		Ordering Number	Item Code	Wt. Kg.
	mm	in.			
Standard	450	18	NS6DV-18-9.625-A45	26714	7.73
	600	24	NS6DV-24-12.625-A45	26715	8.64
	750	30	NS6DV-30-15.625-A45	26716	9.55
	900	36	NS6DV-36-18.625-A45	26717	13.45
	1050	42	NS6DV-42-21.625-A45	26718	14.64
	1200	48	NS6DV-48-24.625-A45	26719	15.91
	1350	54	NS6DV-54-27.625-A45	26720	17.14
	1500	60	NS6DV-60-30.625-A45	26721	18.36
	1800	72	NS6DV-72-36.625-A45	26722	20.77
Heavy-Duty	1200	48	NS7DV-48-24.625-A105	26723	21.05
	1350	54	NS7DV-54-27.625-A105	26724	22.59
	1500	60	NS7DV-60-30.625-A105	26725	24.09
	1800	72	NS7DV-72-36.625-A105	26726	27.14
	2100	84	NS7DV-84-42.625-A105	26727	35.00
	2400	96	NS7DV-96-48.625-A105	26728	39.00

Stock items (non-shaded) refer to (*) for specific lead time, if not specified, standard lead time applies.

Non-stock items (shaded) please contact Flexco for dispatch options and lead times.

Specifications & Guidelines

PT Pro Belt Trainer

Specifications

Maximum Belt Speed	Standard Duty - 5M/sec (1000 fpm) Heavy Duty - 7M/sec (1400 fpm)
Temperature Rating	-35° C to 82° C (-30° F to 180° F)
Belt Direction	One-Way or Reversing
Available for Belt Widths	450 - 2400mm (18" - 96")
Mounting Adjustability	Horizontal = belt width +229 - 381mm (9" to 15") Vertical = 305mm (12")

Selection Guidelines

Model	Application Range
PT Pro™	Medium-duty belts 150 PIW min to 1600 PIW max tension. Belt width 450 - 1800mm (18" - 72")
PT Pro HD	Heavy-duty belts 300 PIW min to 2400 PIW max tension. Belt width 1200 - 2400mm (48" - 96")

*Typical results; actual results may vary

Conveyor Criteria

Top side mistracking	NO
Return side mistracking	YES
Reversing	YES
Belt mistracking to one side	EXCELLENT
Belt mistracking to both sides	EXCELLENT
Inconsistent tracking problem	EXCELLENT
Belt is cupped (heavy)	GOOD
Belt has low running tension (150 - 300 PIW)	GOOD
Belt has medium running tension (300 - 600 PIW)	EXCELLENT
Belt has high running tension (600+ PIW)	GOOD
Approx. "upstream" effect*	6 M (20')
Approx. "downstream" effect*	30 M (100')

Replacement Parts List

PT Pro Belt Trainer

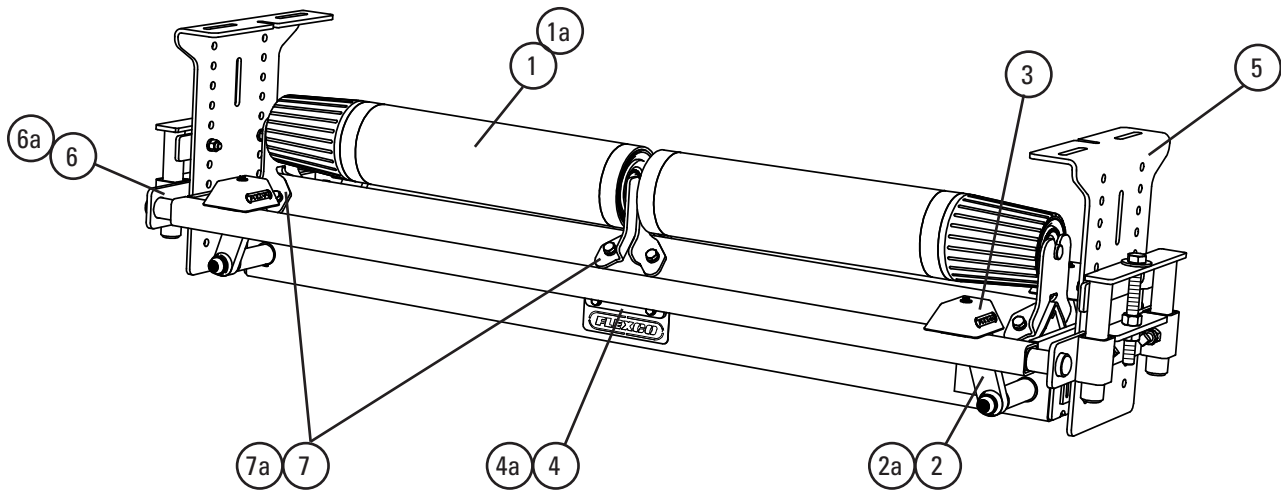

Replacement Idlers

Ref	Belt Width		Description	Ordering Number	Item Code	Wt. Kg.
	mm	in.				
1	450	18	PTPR Idler 18" (450mm)	NS6DV-18-9.625-A45	26714	7.7
	600	24	PTPR Idler 24" (600mm)	NS6DV-24-12.625-A45	26715	8.6
	750	30	PTPR Idler 30" (750mm)	NS6DV-30-15.625-A45	26716	9.5
	900	36	PTPR Idler 36" (900mm)	NS6DV-36-18.625-A45	26717	13.5
	1050	42	PTPR Idler 42" (1050mm)	NS6DV-42-21.625-A45	26718	14.6
	1200	48	PTPR Idler 48" (1200mm)	NS6DV-48-24.625-A45	26719	15.9
	1350	54	PTPR Idler 54" (1350mm)	NS6DV-54-27.625-A45	26720	17.1
	1500	60	PTPR Idler 60" (1500mm)	NS6DV-60-30.625-A45	26721	18.4
	1800	72	PTPR Idler 72" (1800mm)	NS6DV-72-36.625-A45	26722	20.8
1a	1200	48	PTPR HD Idler 48" (1200mm)	NS7EV-48-24.625-A105	26723	21.0
	1350	54	PTPR HD Idler 54" (1350mm)	NS7EV-54-27.625-A105	26724	22.6
	1500	60	PTPR HD Idler 60" (1500mm)	NS7EV-60-30.625-A105	26725	24.1
	1800	72	PTPR HD Idler 72" (1800mm)	NS7EV-72-36.625-A105	26726	27.1
	2100	84	PTPR HD Idler 84" (2100mm)	NS7EV-84-42.625-A105	26727	35.0
2400	96	PTPR HD Idler 96" (2400mm)	NS7EV-96-48.625-A105	26728	39.0	
2		PT Pro Link Bar*	PTPLB	79470	5.3	
2a		PT Pro HD Link Bar*	PTPLB-HD	79473	6.5	
3		PT Pro Link Shield	PTP-LS	79488	0.1	
4		PT Pro Pivot Assy	PTP-RPA	79476	5.9	
4a		PT Pro HD Pivot Assy	PTP-HDRPA	79478	6.5	
5		PT Pro Mounting Bracket	PTP-RMB	79490	10.2	
6		PT Pro Extension Bracket Kit	PTP-EBKR	79484	13.5	
6a		PT Pro HD Extension Bracket Kit	PTP-HDEBKR	79486	16.4	
7		PT Pro Roller Bracket Kit**	PTP-RRB	79491	2.7	
7a		PT Pro HD Roller Bracket Kit**	PTP-HDRBK	79492	3.3	

*Set of 4

**Bracket set for 1 roller

Stock items (non-shaded) refer to (*) for specific lead time, if not specified, standard lead time applies.

Non-stock items (shaded) please contact Flexco for dispatch options and lead times.

Product Ordering Information

PT Max™ Belt Trainer - Mild Steel

Please note that freight for all PT Max™ are ex-works.

PT Max™ Top Side

BELT WIDTH mm	ORDERING NUMBER	WT. KG.
750	PTM-750-3	130.0
900	PTM-900-3	140.0
1050	PTM-1050-3	147.0
1200	PTM-1200-3	155.0
1350	PTM-1350-3	161.0
1500	PTM-1500-3	164.0
1600	PTM-1600-3	168.0
1800	PTM-1800-3	186.0
2000	PTM-2000-3	204.0
2400	PTM-2400-3	240.0
2600	PTM-2600-3	258.0
3000	PTM-3000-3	294.0

Finish: Steel parts are sandblasted, primed, and powder coated



PT MAX TOP SIDE BELT TRAINER:
The PT MAX is delivered without rollers, but is manufactured to accommodate on site rollers.
Includes Servo Rollers.

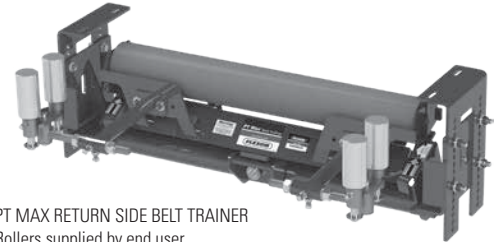

PT MAX RETURN SIDE BELT TRAINER
Rollers supplied by end user.

PT Max™ Return Side

BELT WIDTH mm	ORDERING NUMBER	WT. KG.
750	PTM-750-1	130.0
900	PTM-900-1	140.0
1050	PTM-1050-1	147.0
1200	PTM-1200-1	155.0
1350	PTM-1350-1	161.0
1500	PTM-1500-1	164.0
1600	PTM-1600-1	168.0
1800	PTM-1800-1	186.0
2000	PTM-2000-1	204.0
2400	PTM-2400-1	240.0
2600	PTM-2600-1	258.0
3000	PTM-3000-1	294.0

Finish: Steel parts are sandblasted, primed, and powder coated

PT Max™ V-Return

BELT WIDTH mm	ORDERING NUMBER	WT. KG.
750	PTM-750-2	130.0
900	PTM-900-2	140.0
1050	PTM-1050-2	147.0
1200	PTM-1200-2	155.0
1350	PTM-1350-2	161.0
1500	PTM-1500-2	164.0
1600	PTM-1600-2	168.0
1800	PTM-1800-2	186.0
2000	PTM-2000-2	204.0
2400	PTM-2400-2	240.0
2600	PTM-2600-2	258.0
3000	PTM-3000-2	294.0

Finish: Steel parts are sandblasted, primed, and powder coated

Replacement Servo Rollers

DESCRIPTION	ORDERING NUMBER	ITEM CODE	WT. KG.
SERVO 149x102	PTMSR	A0235	2.0
PTM Sensor Roller 75mmx102	MSR	74914	3.0



PT MAX V-RETURN BELT TRAINER

Product Notes:

- Please note PT Max™ no longer utilises generic item codes. Each PT Max is specifically engineered and is allocated a unique 6 digit item code upon manufacture which is also the serial number.
- FPT Max™ is custom manufactured to suit your requirements. Manufacture cannot commence without a data sheet; contact Flexco® for specification order sheet.
- For larger sizes please contact Flexco (Aust) Pty Ltd.
- Please note that PT Max™ freight terms are ex-works Bundaberg.
- Also available in other roller configurations—please contact Flexco.
- PT Max™ lead time is 4 weeks ex-Bundaberg from the receipt of an order and all data requirements.

U.S. Patent No. 5,358,098

Product Ordering Information

PT Max™ Belt Trainer - Stainless Steel

Please note that freight for all PT Max™ are ex-works.

PT Max™ Top Side

BELT WIDTH mm	ORDERING NUMBER	WT. KG.
750	PTM-750-3-S/S	130.0
900	PTM-900-3-S/S	140.0
1050	PTM-1050-3-S/S	147.0
1200	PTM-1200-3-S/S	155.0
1350	PTM-1350-3-S/S	161.0
1600	PTM-1600-3-S/S	168.0
1800	PTM-1800-3-S/S	186.0
2000	PTM-2000-3-S/S	204.0
2400	PTM-2400-3-S/S	240.0
2600	PTM-2600-3-S/S	258.0
3000	PTM-3000-3-S/S	294.0

Finish: Steel parts are sandblasted, primed, and powder coated

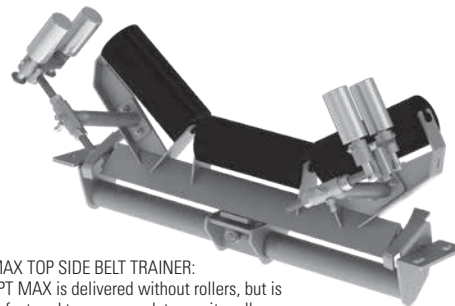

PT MAX TOP SIDE BELT TRAINER:
The PT MAX is delivered without rollers, but is manufactured to accommodate on site rollers.
Includes Servo Rollers.

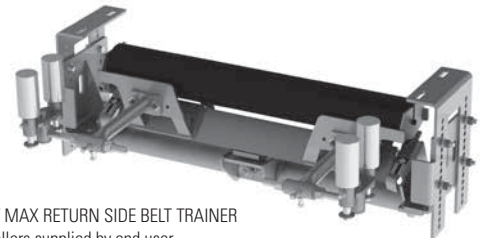

PT MAX RETURN SIDE BELT TRAINER
Rollers supplied by end user.

PT Max™ Return Side

BELT WIDTH mm	ORDERING NUMBER	WT. KG.
750	PTM-750-1-S/S	130.0
900	PTM-900-1-S/S	140.0
1050	PTM-1050-1-S/S	147.0
1200	PTM-1200-1-S/S	155.0
1350	PTM-1350-1-S/S	161.0
1600	PTM-1600-1-S/S	168.0
1800	PTM-1800-1-S/S	186.0
2000	PTM-2000-1-S/S	204.0
2400	PTM-2400-1-S/S	240.0
2600	PTM-2600-1-S/S	258.0
3000	PTM-3000-1-S/S	294.0

Finish: Steel parts are sandblasted, primed, and powder coated

PT Max™ V-Return

BELT WIDTH mm	ORDERING NUMBER	WT. KG.
750	PTM-750-2-S/S	130.0
900	PTM-900-2-S/S	140.0
1050	PTM-1050-2-S/S	147.0
1200	PTM-1200-2-S/S	155.0
1350	PTM-1350-2-S/S	161.0
1600	PTM-1600-2-S/S	168.0
1800	PTM-1800-2-S/S	186.0
2000	PTM-2000-2-S/S	204.0
2400	PTM-2400-2-S/S	240.0
2600	PTM-2600-2-S/S	258.0
3000	PTM-3000-2-S/S	294.0

Finish: Steel parts are sandblasted, primed, and powder coated

Replacement Servo Rollers

DESCRIPTION	ORDERING NUMBER	ITEM CODE	WT. KG.
PTM Sensor Roller 75mmx102	MSR-S/S	79378	3.0

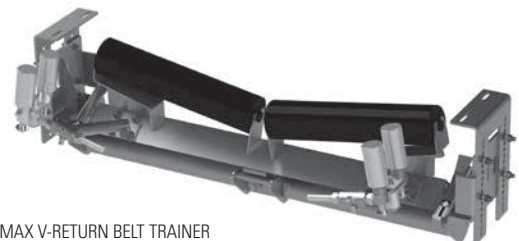

PT MAX V-RETURN BELT TRAINER

Product Notes:

- Please note PT Max™ no longer utilises generic item codes. Each PT Max is specifically engineered and is allocated a unique 6 digit item code upon manufacture which is also the serial number.
- PT Max™ is custom manufactured to suit your requirements. Manufacture cannot commence without a data sheet; contact Flexco® for specification order sheet.
- Stainless Steel PT Max™ is made from 304 Stainless Steel as standard, please specify specific requirements in the data sheet.
- For larger sizes please contact Flexco (Aust) Pty Ltd.
- Please note that PT Max™ freight terms are ex-works Bundaberg.
- Also available in other roller configurations—please contact Flexco.
- PT Max™ lead time is 4 weeks ex-Bundaberg from the receipt of an order and all data requirements.

Replacement Parts List

PT Max™
Belt Trainer

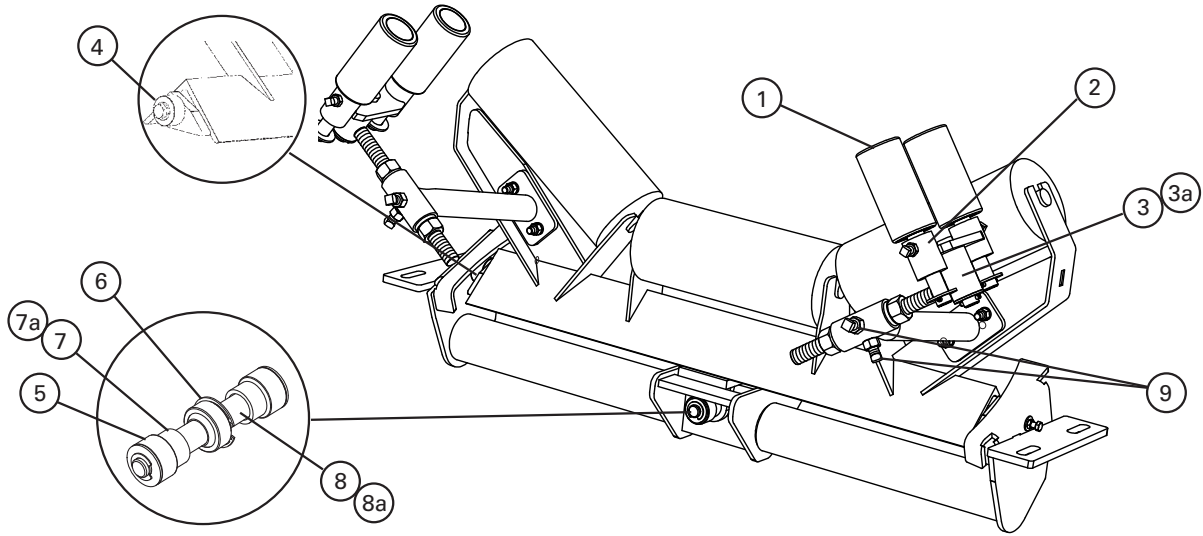

Replacement Parts

REF	DESCRIPTION	BELT WIDTH (mm)	MILD STEEL		STAINLESS STEEL	
			ORDERING NUMBER	ITEM CODE	ORDERING NUMBER	ITEM CODE
1	Sensor Roller* (3" solid roller) (1 ea.)	750-2100	MSR	74914	MSR-S/S	64924
2	Swivel Mount Kit*	750-2100	PMSMK	74916	PMSMK-S/S	64925
3	Adjusting Arm Kit*	750-1500	MAK	74918	MAK-S/S	64926
3a	HD Adjusting Arm Kit*	1350-2100	MAKHD	74919	MAKHD	74919
4	Outer Roller Kit* (incl. 2 rollers, roller thimbles and bolts, nuts and washers)	750-2100	MORK	74921	MORK	74921
5	Center Roller Kit* (incl. 2 rollers, 2 washers, and 2 cotter pins)	750-2100	MCRK	74923	MCRK	74923
6	Center Bearing*	750-2100	MCB	74925	MCB	74925
7	Center Shaft Spacer Kit (incl. 2 spacers)	750-1500	MCSK	74927	MCSK	74927
7a	HD Center Shaft Spacer Kit (incl. 2 spacers)	1350-2100	MCSKHD	74928	MCSKHD	74928
8	Center Shaft	750-1500	MCS	74930	MCS	74930
8a	HD Center Shaft	1350-2100	MCSHD	74931	MCSHD	74931
9	Frame Arm Set Screw Kit (incl. 2 setscrews and 2 jam nuts)	750-3000	MFASK	75531	MFASK	75531
-	Center Bearing Kit (incl. 1 ea. items 5, 6, 7, 8)	750-1500	MCBK	76025	MCBK	76025
-	HD Center Bearing Kit (incl. 1 ea. items 5, 6, 7a, 8a)	1350-2100	MCBKHD	76026	MCBKHD	76026

Lead time: 3 weeks

Stock items (non-shaded) refer to (*) for specific lead time, if not specified, standard lead time applies.

Non-stock items (shaded) please contact Flexco for dispatch options and lead times.

Product Ordering Information

RMC1 Skirt Clamps

Flex-Lok™ Skirt Clamp-Mild Steel

- One Standard Skirt Clamp includes one 2 M mounting channel, 4 clamp plates, 4 clamp pins and one 2 M restraining bar.
- One Mini Skirt Clamp includes one 2 M mounting channel, 3 clamp plates, 3 clamp pins and one 2 M restraining bar.
- Skirt board and rubber not included.

DESCRIPTION	ORDERING NUMBER	ITEM CODE	WT. KG.
Flex-Lok™ Skirt Clamp Complete	FLSC2000	71053	18.0
Mini Flex-Lok™ Skirt Clamp Complete	FLSCM2000	71148	15.0
REPLACEMENT PARTS			
Toggle Pin	FLSC-TP	71056	1.0
Clamp Plate	FLSC-CP	71057	1.0
Mini Clamp Plate	FLSCM-CP	71140	1.0
Clamp Bar-2000 mm	FLSC2000-CB	71061	5.0
Mounting Channel-2000 mm	FLSC2000-MC	71059	3.0

Finish: Clamp plates and clamp bars are powder coated steel. Mounting channel is powder coated. Toggle pins are zinc passivated steel. Skirt rubber is not included.

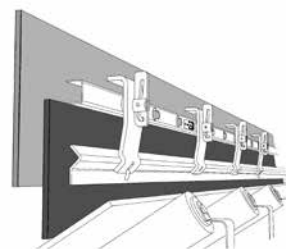

Standard

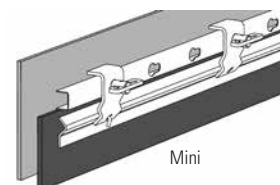

Mini

Flex-Lok™ Skirt Clamp-Stainless Steel

- One Standard Skirt Clamp includes one 2 M mounting channel, 4 clamp plates, 4 clamp pins and one 2 M restraining bar.
- One Mini Skirt Clamp includes one 2 M mounting channel, 3 clamp plates, 3 clamp pins and one 2 M restraining bar.
- Skirt board and rubber not included.

DESCRIPTION	ORDERING NUMBER	ITEM CODE	WT. KG.
Flex-Lok™ Skirt Clamp Complete	FLSC2000-S/S	A1436	20.0
Mini Flex-Lok™ Skirt Clamp Complete	FLSCM2000-S/S	61471	15.0
REPLACEMENT PARTS			
Toggle Pin	FLSC-TP-S/S	A1437	1.0
Clamp Plate	FLSC-CP-S/S	A1438	1.0
Mini Clamp Plate	FLSCM-CP-S/S	A2596	1.0
Clamp Bar-2000 mm	FLSC2000-CB-S/S	A1439	5.0
Mounting Channel-2000 mm	FLSC2000-MC-S/S	A1440	3.0

All components supplied in 300 Series Stainless.

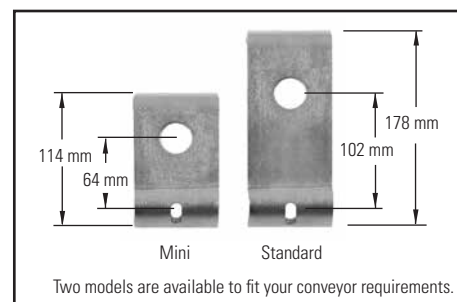

Two models are available to fit your conveyor requirements.

Flex-Lok™ Specifications

SKIRT RUBBER THICKNESS RANGE	
Thickness Range	8-25 mm

Product Notes:

- Solves material spillage problems in the conveyor loading zone.
- Stops material loss, eliminates safety hazards, and reduces wear on conveyor components.

 **Stock items** (non-shaded) refer to (*) for specific lead time, if not specified, standard lead time applies.

 **Non-stock items** (shaded) please contact Flexco for dispatch options and lead times.

Product Ordering Information

RMC1 Skirt Clamps

Flex-Seal™ Skirt System

DESCRIPTION	ORDERING NUMBER	ITEM CODE	WT. KG.
Flex-Seal™ Skirt System*	RMC-FS	76558	13.4
REPLACEMENT PARTS**			
Angle Plate	RMC2-AP	76559	8.6
Angle Plate Stainless Steel	RMC2-AP-S/S	A2704	8.6
PAL PAK	RMC1-PP	75832	3.0
Bolt-On PAL PAK	RMC1-BPP	76415	3.0
Clamp Bar	RMC1-CB	75817	1.8

*Flex-Seal Skirt System includes angle plate, one Bolt-On PAL PAK, and one 1.2 M clamp bar. Skirt board and rubber not included. Skirt rubber thickness range: 8 mm to 19 mm

**Replacement parts include two Bolt-On clamp pins and two clamp plates.

Flex-Seal™ Specifications

SKIRT RUBBER THICKNESS RANGE	
Width Required	150 mm
Thickness Range	8-19 mm



Bolt-On PAL PAK

 Stock items (non-shaded) refer to (*) for specific lead time, if not specified, standard lead time applies.

 Non-stock items (shaded) please contact Flexco for dispatch options and lead times.

Product Ordering Information

Standard Urethane Skirting



Standard Urethane Skirting

Height		Thickness		Length		CHAMFER	ORDERING NUMBER	ITEM CODE	WT. KG.
mm	in	mm	in	m	ft				
150	6	12	1/2	7.6	25	35°	SKPU-6x1/2x25	90283	18.1
150	6	20	3/4				SKPU-6x3/4x25	90284	27.3
200	8	12	1/2				SKPU-6x1/2x25	90285	26.4
200	8	20	3/4				SKPU-6x3/4x25	90286	40.0

Stock items (non-shaded) lead time 1 working day.

Non-stock items (shaded) please refer to Flexco for dispatch options and lead times.

Standard Urethane Skirting with 35° Chamfer* - 7.6 M (25')

Height		Thickness		Length		ORDERING NUMBER	ITEM CODE	WT. KG.
mm	in	mm	in	m	ft			
100	4	10	3/8	7.6	25	SKPU-4X3/8X25	91288	21.2
100	4	12	1/2	7.6	25	SKPU-4X1/2X25	91289	28.2
100	4	16	5/8	7.6	25	SKPU-4X5/8X25	91290	35.3
100	4	19	3/4	7.6	25	SKPU-4X3/4X25	91291	42.3
100	4	25	1	7.6	25	SKPU-4X1X25	91292	56.4
150	6	10	3/8	7.6	25	SKPU-6X3/8X25	91298	31.7
150	6	16	5/8	7.6	25	SKPU-6X5/8X25	91299	52.9
150	6	25	1	7.6	25	SKPU-6X1X25	91300	84.6
200	8	10	3/8	7.6	25	SKPU-8X3/8X25	91304	42.3
200	8	16	5/8	7.6	25	SKPU-8X5/8X25	91305	70.5
200	8	25	1	7.6	25	SKPU-8X1X25	91306	112.8
250	10	10	3/8	7.6	25	SKPU-10X3/8X25	91310	52.9
250	10	12	1/2	7.6	25	SKPU-10X1/2X25	91311	70.5
250	10	16	5/8	7.6	25	SKPU-10X5/8X25	91312	88.1
250	10	19	3/4	7.6	25	SKPU-10X3/4X25	91313	105.8
250	10	25	1	7.6	25	SKPU-10X1X25	91314	141.0
300	12	10	3/8	7.6	25	SKPU-12X3/8X25	91320	63.5
300	12	12	1/2	7.6	25	SKPU-12X1/2X25	91321	84.6
300	12	16	5/8	7.6	25	SKPU-12X5/8X25	91322	105.8
300	12	19	3/4	7.6	25	SKPU-12X3/4X25	91323	126.9
300	12	25	1	7.6	25	SKPU-12X1X25	91324	169.2

Standard Urethane Skirting with 35° Chamfer* - 15.2 M (50')

Height		Thickness		Length		ORDERING NUMBER	ITEM CODE	WT. KG.
mm	in	mm	in	m	ft			
100	4	10	3/8	15.2	50	SKPU-4X3/8X50	91293	42.3
100	4	12	1/2	15.2	50	SKPU-4X1/2X50	91294	56.4
100	4	16	5/8	15.2	50	SKPU-4X5/8X50	91295	70.5
100	4	19	3/4	15.2	50	SKPU-4X3/4X50	91296	84.6
100	4	25	1	15.2	50	SKPU-4X1X50	91297	112.8
150	6	10	3/8	15.2	50	SKPU-6X3/8X50	91301	63.5
150	6	12	1/2	15.2	50	SKPU-6X1/2X50	91222	84.6
150	6	16	5/8	15.2	50	SKPU-6X5/8X50	91302	105.8
150	6	19	3/4	15.2	50	SKPU-6X3/4X50	91223	126.9
150	6	25	1	15.2	50	SKPU-6X1X50	91303	169.2
200	8	10	3/8	15.2	50	SKPU-8X3/8X50	91307	84.6
200	8	12	1/2	15.2	50	SKPU-8X1/2X50	91224	112.8
200	8	16	5/8	15.2	50	SKPU-8X5/8X50	91308	141.0
200	8	19	3/4	15.2	50	SKPU-8X3/4X50	91225	169.2
200	8	25	1	15.2	50	SKPU-8X1X50	91309	225.6
250	10	10	3/8	15.2	50	SKPU-10X3/8X50	91315	105.8
250	10	12	1/2	15.2	50	SKPU-10X1/2X50	91316	141.0
250	10	16	5/8	15.2	50	SKPU-10X5/8X50	91317	176.3
250	10	19	3/4	15.2	50	SKPU-10X3/4X50	91318	211.5
250	10	25	1	15.2	50	SKPU-10X1X50	91319	282.0
300	12	10	3/8	15.2	50	SKPU-12X3/8X50	91325	126.9
300	12	12	1/2	15.2	50	SKPU-12X1/2X50	91326	169.2
300	12	16	5/8	15.2	50	SKPU-12X5/8X50	91327	211.5
300	12	19	3/4	15.2	50	SKPU-12X3/4X50	91328	253.8
300	12	25	1	15.2	50	SKPU-12X1X50	91329	338.4

*Please contact Flexco for pricing and availability

Product Notes:

- Urethane skirting offers a more wear-resistant material than typical rubber, often providing as much as 3-4 times the wear life in similar applications. The lower coefficient of friction reduces strain on the system.
- Works with Flexco series of skirt clamps that offer simple serviceability: RMC1/PAL-Pak, Flex-Lok, and Flex-Seal.
- Uses soft durometer (65A) urethane with exceptional tear resistance to ensure a good seal and long belt life.
- 7.6M (25') roll size ensures easy transportation, while the 35° chamfer eliminates the typical skirting break-in period.
- Suitable for most applications: single direction or reversing belts, wet or dry conditions, old or new belts, vulcanised or mechanically-spliced systems.
- Rated for temperatures from -30°C to 82°C (-20°F to 180°F)

Stock items (non-shaded) refer to (*) for specific lead time, if not specified, standard lead time applies.

Non-stock items (shaded) please contact Flexco for dispatch options and lead times.

Product Ordering Information

Flexco® Belt Maintenance Tools Belt Lifters & Clamps

Flex-Lifter™ Conveyor Belt Lifter

Easy and safe way to lift tensioned belts so mechanical splicing or other maintenance work can be done.



DESCRIPTION	ORDERING NUMBER	ITEM CODE	WT. KG.
Medium Flex-Lifter 900 - 1500 mm	FL-M	76979	27.3
Large Flex-Lifter 1200 - 1800 mm	FL-L	76980	33.6
XL Flex-Lifter 1800 - 2400 mm	FL-XL	76983	68.5
OPTIONAL PARTS			
Extension Leg - Medium	FLEL-M	76472	1.4
Extension Leg - Large	FLEL-L	76473	1.7
Extension Leg - XL (includes 2 ext. legs)	FLELK-XL	76986	5.9
Extension Leg Pin (with lanyard)	FLELP	76474	0.1
Trough Wing - Medium (with brace)	FTW-M	76476	0.6
Trough Wing - Large (with brace)	FTW-L	76477	0.7
Trough Wing - XL (with brace)	FTW-XL	76985	2.0
Retainer Pin Pack (includes 4 pins)	FLRP	76478	0.5
Retainer Clip Pack (includes 4 clips)	FLCP	76479	0.1
Return Lift Bar - Medium	FLRLB-M	76482	8.4
Return Lift Bar - Large	FLRLB-L	76481	18.2
V-Return Lift Bar - XL	FLVRL-XL	76984	28.6
Flex-Trolley	N/A	77729	N/A

Return lift bars included with medium and large models. Sold separately with XL models.

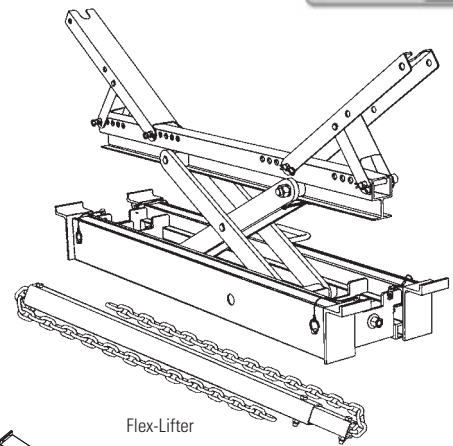

Flex-Lifter

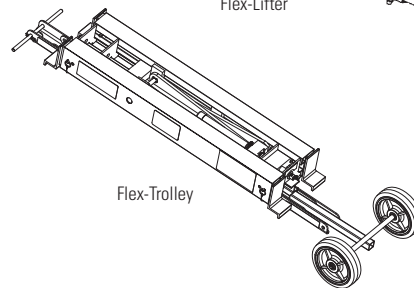

Flex-Trolley

Aluminum Content Flex-Lifter

ALUMINUM ALLOY TYPE	PERCENT	
	MG-MAGNESIUM	TI-TITANIUM
4043	0.05%	0.2%
5356	5.5%	0.2%
6005	0.6%	0.1%
6061	1.0%	0.0%
6063	0.7%	0.0%
7075	2.5%	0.0%

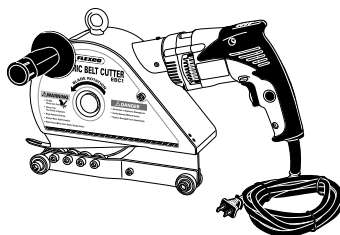

Electric Belt Cutter

Electric Belt Cutter

DESCRIPTION	ORDERING NUMBER	ITEM CODE	WT. KG.
Electric Cutter Complete - 25 mm	EBC-1	30001	9.0
Electric Cutter Complete - 50 mm	EBC-2	30002	10.0
Cordless Electric Cutter Complete - 25 mm	CEBC-1	30018	9.0
Cordless Electric Cutter Complete - 50 mm	CEBC-2	30019	10.0
REPLACEMENT PARTS			
Replacement blade for EBC-1	EBC-1-B	30003	1.0
Replacement blade for EBC-2	EBC-2-B	30004	1.0
Retrofit Rail Kit for EBC1/CEBC1/PBC1	EBC1-RK	30033	0.6
Retrofit Rail Kit for EBC2/CEBC2/PBC2	EBC2-RK	30034	0.8

Pneumatic Belt Cutter

DESCRIPTION	ORDERING NUMBER	ITEM CODE	WT. KG.
Pneumatic Cutter Complete - 25 mm	PBC-1	61356	12.5
Pneumatic Cutter Complete - 50 mm	PBC-2	61357	13.5
REPLACEMENT PARTS			
Filter Set	PBC-FR	61358	2.0

Cutting Capacity

BELT TYPE	EBC-1	EBC-2
Rubber	Up to 25 mm	Up to 50 mm
PVC	Up to 630 EP	Up to 2000 EP

Stock items (non-shaded) refer to (*) for specific lead time, if not specified, standard lead time applies.

Non-stock items (shaded) please contact Flexco for dispatch options and lead times.

INDEX By Ordering Number

Ordering Number	Item Code	Page #	Ordering Number	Item Code	Page #	Ordering Number	Item Code	Page #	Ordering Number	Item Code	Page #
ABU	76788	110	BP-UB	73139	144	BP900	73108	143	CART-60/1500-S/S	78582	98
ABU	76788	110	BP1050	73110	143	BP900-B	73779	144	CART-60/1500-S/S	78582	103
ABU	76788	111	BP1050-B	73780	144	BP900-HD-B	73302	144	CART-60/1500-S/S	78582	104
ABU	76788	111	BP1050-HD-B	73304	144	BP900-S/S	76341	143	CART-72/1800-S/S	78583	47
ACME-N	62591	55	BP1050-S/S	76342	143	C-PSTA	81045	110	CART-72/1800-S/S	78583	53
ACME-N	62591	55	BP1200	73112	143	CART-24/600-S/S	78576	47	CART-72/1800-S/S	78583	82
ACME-N	62591	55	BP1200-1400-PL	73118	144	CART-24/600-S/S	78576	53	CART-72/1800-S/S	78583	84
ACME-N	62591	55	BP1200-1400-PL-S/S	A0621	144	CART-24/600-S/S	78576	82	CART-72/1800-S/S	78583	89
ACME-PRK	62496	55	BP1200-1400MF	73154	144	CART-24/600-S/S	78576	84	CART-72/1800-S/S	78583	91
ACME-PRK	62496	55	BP1200-1400MF-S/S			CART-24/600-S/S	78576	89	CART-72/1800-S/S	78583	96
ACME-PRK	62496	55	MAIN FRAME	A0620	144	CART-24/600-S/S	78576	91	CART-72/1800-S/S	78583	98
ACME-PRK	62496	55	BP1200-B	73781	144	CART-24/600-S/S	78576	96	CART-72/1800-S/S	78583	103
AIR BAG P	62036	55	BP1200-HD-B	73306	144	CART-24/600-S/S	78576	98	CART-72/1800-S/S	78583	104
AIR HARK-S/S-60	62035	55	BP1200-S/S	76343	143	CART-24/600-S/S	78576	103	CART2-114/2850-S/S	78639	48
AIR HARK-S/S-73	64175	55	BP1400	73113	143	CART-24/600-S/S	78576	104	CART2-114/2850-S/S	78639	54
AIR HDMRK S/S	62034	55	BP1400-B	73782	144	CART-30/750-S/S	78577	82	CART2-120/3000-S/S	78588	48
ATV-ANGLE	62426	72	BP1400-HD-B	73307	144	CART-30/750-S/S	78577	84	CART2-120/3000-S/S	78588	54
ATV-ANGLE	62426	77	BP1400-S/S	76344	143	CART-30/750-S/S	78577	89	CART2-120/3000-S/S	78588	82
ATV-ANGLE	62426	97	BP1500	73114	143	CART-30/750-S/S	78577	91	CART2-120/3000-S/S	78588	84
ATV-BAG	62036	72	BP1500-1600-PL	73119	144	CART-30/750-S/S	78577	96	CART2-120/3000-S/S	78588	89
ATV-BAG	62079	77	BP1500-1600-PL-S/S	A0647	144	CART-30/750-S/S	78577	98	CART2-120/3000-S/S	78588	91
ATV-BAG	62079	97	BP1500-1600MF	73147	144	CART-30/750-S/S	78577	103	CART2-120/3000-S/S	78588	96
ATV-MOUNT	62424	72	BP1500-1600MF-S/S			CART-30/750-S/S	78577	104	CART2-120/3000-S/S	78588	98
ATV-MOUNT	63073	72	MAIN FRAME	A0646	144	CART-36/900-S/S	78578	47	CART2-120/3000-S/S	78588	103
ATV-MOUNT	62424	77	BP1500-B	73784	144	CART-36/900-S/S	78578	53	CART2-120/3000-S/S	78588	105
ATV-MOUNT	63073	77	BP1500-HD-B	73308	144	CART-36/900-S/S	78578	82	CART2-126/3150-S/S	78640	48
ATV-MOUNT	62424	97	BP1500-S/S	76345	143	CART-36/900-S/S	78578	84	CART2-126/3150-S/S	78640	54
ATV-MOUNT	63073	97	BP1600	73115	143	CART-36/900-S/S	78578	89	CART2-48/1200-S/S	78580	47
ATV-NIP	62037	55	BP1600-B	73784	144	CART-36/900-S/S	78578	91	CART2-48/1200-S/S	78580	53
ATV-NIP	62037	72	BP1600-HD-B	73309	144	CART-36/900-S/S	78578	96	CART2-60/1500-S/S	78584	48
ATV-NIP	62037	77	BP1600-S/S	76346	143	CART-36/900-S/S	78578	98	CART2-60/1500-S/S	78584	54
ATV-NIP	62037	97	BP1800	73117	143	CART-36/900-S/S	78578	103	CART2-60/1500-S/S	78584	82
ATV-SLIDE	62425	72	BP1800-B	73785	144	CART-36/900-S/S	78578	104	CART2-60/1500-S/S	78584	84
ATV-SLIDE	62425	77	BP1800-HD-B	73311	144	CART-42/1050-S/S	78579	47	CART2-60/1500-S/S	78584	89
ATV-SLIDE	62425	97	BP1800-PL	73121	144	CART-42/1050-S/S	78579	53	CART2-60/1500-S/S	78584	91
ATVK-60	62409	72	BP1800-PL-S/S	A1547	144	CART-42/1050-S/S	78579	82	CART2-60/1500-S/S	78584	96
ATVK-60	62409	77	BP1800-S/S	76347	143	CART-42/1050-S/S	78579	84	CART2-60/1500-S/S	78584	98
ATVK-60	62409	97	BP1800MF	73148	144	CART-42/1050-S/S	78579	89	CART2-60/1500-S/S	78584	103
ATVK-73	63072	72	BP1800MF-S/S			CART-42/1050-S/S	78579	91	CART2-60/1500-S/S	78584	105
ATVK-73	63072	77	MAIN FRAME	A1546	144	CART-42/1050-S/S	78579	96	CART2-66/1650-S/S	78634	48
ATVK-73	63072	97	BP2000MF	A1996	144	CART-42/1050-S/S	78579	98	CART2-66/1650-S/S	78634	54
AWT	75904	26	BP450	73102	143	CART-42/1050-S/S	78579	103	CART2-72/1800-S/S	78585	48
AWT	75904	32	BP450-750-PL	73109	144	CART-42/1050-S/S	78579	104	CART2-72/1800-S/S	78585	54
AWT-1S	76375	26	BP450-750-PL-S/S	A0683	144	CART-48/1200-S/S	78580	82	CART2-72/1800-S/S	78585	82
AWT-1S	76375	32	BP450-750MF	73152	144	CART-48/1200-S/S	78580	84	CART2-72/1800-S/S	78585	84
AWTA	75907	26	BP450-750MF-S/S			CART-48/1200-S/S	78580	89	CART2-72/1800-S/S	78585	89
AWTA	75907	32	MAIN FRAME	A0682	144	CART-48/1200-S/S	78580	91	CART2-72/1800-S/S	78585	91
AWTB	75905	26	BP450-B	74055	144	CART-48/1200-S/S	78580	96	CART2-72/1800-S/S	78585	96
AWTB	75905	32	BP450-HD-B	A0223	144	CART-48/1200-S/S	78580	98	CART2-72/1800-S/S	78585	98
AWTCB	75908	26	BP450-S/S	76337	143	CART-48/1200-S/S	78580	103	CART2-72/1800-S/S	78585	103
AWTCB	75908	32	BP600	73104	143	CART-48/1200-S/S	78580	104	CART2-72/1800-S/S	78585	105
AWTHK	75909	26	BP600-B	73777	144	CART-54/1350-S/S	78581	82	CART2-78/1950-S/S	78635	48
AWTHK	75909	32	BP600-HD-B	A0224	144	CART-54/1350-S/S	78581	84	CART2-78/1950-S/S	78635	54
AWTMB	75906	26	BP600-S/S	76338	143	CART-54/1350-S/S	78581	89	CART2-78/1950-S/S	78635	82
AWTMB	75906	32	BP750	73106	143	CART-54/1350-S/S	78581	91	CART2-78/1950-S/S	78635	84
AWTNCB	76069	26	BP750-B	73778	144	CART-54/1350-S/S	78581	96	CART2-78/1950-S/S	78635	89
AWTNCB	76069	32	BP750-HD-B	A2237	144	CART-54/1350-S/S	78581	98	CART2-78/1950-S/S	78635	91
BP-LA	73127	144	BP750-S/S	76339	143	CART-54/1350-S/S	78581	103	CART2-78/1950-S/S	78635	96
BP-LA-S/S	A0614	144	BP800	73107	143	CART-54/1350-S/S	78581	104	CART2-78/1950-S/S	78635	98
BP-MB	73123	144	BP800-1050-PL	73111	144	CART-60/1500-S/S	78582	47	CART2-78/1950-S/S	78635	103
BP-MB-S/S	A0615	144	BP800-1050-PL-S/S	A0613	144	CART-60/1500-S/S	78582	53	CART2-78/1950-S/S	78635	105
BP-SC	73125	144	BP800-1050MF	73153	144	CART-60/1500-S/S	78582	82	CART2-84/2100-S/S	78586	48
BP-SC-S/S	A0616	144	BP800-1050MF-S/S			CART-60/1500-S/S	78582	84	CART2-84/2100-S/S	78586	54
BP-TB	73738	144	MAIN FRAME	A0612	144	CART-60/1500-S/S	78582	89	CART2-84/2100-S/S	78586	82
BP-TL	73141	144	BP800-B	74057	144	CART-60/1500-S/S	78582	91	CART2-84/2100-S/S	78586	84
BP-TL-S/S	A0617	144	BP800-HD-B	73301	144	CART-60/1500-S/S	78582	96	CART2-84/2100-S/S	78586	89
			BP800-S/S	76340	143	CART-60/1500-S/S	78582				

INDEX By Ordering Number

Ordering Number	Item Code	Page #	Ordering Number	Item Code	Page #	Ordering Number	Item Code	Page #	Ordering Number	Item Code	Page #
CART2-84/2100-S/S	78586	91	CBD-ST-XL-P-S/S	64625	150	CDS36	76687	117	CRB-W40	78476	19
CART2-84/2100-S/S	78586	96	CBD-ST-XL-PS	64778	150	CDS42	76688	117	CRB-W46	78477	19
CART2-84/2100-S/S	78586	98	CBD-ST-XL-PS-S/S	64782	150	CDS48	76689	117	CRB-W52	78478	19
CART2-84/2100-S/S	78586	103	CBD-ST-XL-S	63024	150	CDS54	76690	117	CRB-W58	78479	19
CART2-84/2100-S/S	78586	105	CBD-ST-XL-S/S	A2138	150	CDS60	76691	117	CRB-W64	78480	19
CART2-96/2400-S/S	78587	48	CBD-ST-XXL	63747	150	CEBC-1	30018	169	CRB-W70	78481	19
CART2-96/2400-S/S	78587	54	CBD-ST-XXL-B	64622	150	CEBC-2	30019	169	CRB16	75629	19
CART2-96/2400-S/S	78587	82	CBD-ST-XXL-FP	63751	150	CFG-212	78838	15	CRB22	75630	19
CART2-96/2400-S/S	78587	84	CBD-ST-XXL-FR-B	63752	150	CFG-218	78839	15	CRB28	75631	19
CART2-96/2400-S/S	78587	89	CBD-ST-XXL-MF	63749	150	CFG-224	78840	15	CRB34	75632	19
CART2-96/2400-S/S	78587	91	CBD-ST-XXL-MF-S/S	63750	150	CFG-230	78841	15	CRB40	75633	19
CART2-96/2400-S/S	78587	96	CBD-ST-XXL-P	64775	150	CFG-236	78842	15	CRB46	75634	19
CART2-96/2400-S/S	78587	98	CBD-ST-XXL-P-S/S	64626	150	CFG-242	78843	15	CRB52	75635	19
CART2-96/2400-S/S	78587	103	CBD-ST-XXL-PS	64779	150	CFG-248	78844	15	CRB58	75636	19
CART2-96/2400-S/S	78587	105	CBD-ST-XXL-PS-S/S	64783	150	CFG-254	78845	15	CRB64	75775	19
CBC18	76668	117	CBD-ST-XXL-S	63791	150	CFG-260	78846	15	CRB70	75773	19
CBC24	76669	117	CBD-ST-XXL-S/S	63748	150	CFG-272	78847	15	CRDF18	90631	117
CBC30	76670	117	CBD-XL	76445	149	CLSGF-212	77144	10	CRDF24	90632	117
CBC36	76671	117	CBD-XL-S/S	76318	149	CLSGF-218	77145	10	CRDF30	90633	117
CBC3R	90641	117	CBD-XXL	64787	149	CLSGF-224	77146	10	CRDF36	90634	117
CBC42	76672	117	CBD-XXL-S/S	63554	149	CLSGF-230	77147	10	CRDF42	90635	117
CBC48	76673	117	CBR-L	72485	149	CLSGF-236	77148	10	CRDF48	90636	117
CBC54	76674	117	CBR-M	72484	149	CLSGF-242	77149	10	CRDF54	90637	117
CBC60	76675	117	CBR-S	72483	149	CLSGF-248	77150	10	CRDF60	90638	117
CBD-L	76444	149	CBR-XL	72486	149	CLSGF-254	77151	10	CRDLBLK-LH-S/S	A2826	85
CBD-L-S/S	A1856	149	CCKHDL	79225	64	CLSGF-260	77152	10	CRDLBLK-LH-S/S	A2826	92
CBD-M	76443	149	CCKHDL	79225	66	CPB	76692	117	CRDLBLK-LH-S/S	A2826	105
CBD-M-S/S	A1854	149	CCKHDL	79225	74	CRB-HT10	76593	19	CRDLBLK-RH-S/S	A2825	85
CBD-S	76442	149	CCKHDL-S/S	79227	64	CRB-HT16	76594	19	CRDLBLK-RH-S/S	A2825	92
CBD-S-S/S	64178	149	CCKHDL-S/S	79227	66	CRB-HT22	76595	19	CRDLBLK-RH-S/S	A2825	105
CBD-ST-AA	61096	150	CCKHDL-S/S	79227	74	CRB-HT28	76596	19	CRHMK	62400	83
CBD-ST-B	64620	150	CCKHDR	79229	64	CRB-HT34	76597	19	CRHMK	62400	90
CBD-ST-BB	64310	150	CCKHDR	79229	66	CRB-HT40	76598	19	CRHMK	62400	103
CBD-ST-CS-S/S	A2215	150	CCKHDR	79229	74	CRB-HT46	76599	19	CRHMK-S/S	62095	85
CBD-ST-FR-B	61111	150	CCKHDR-S/S	79231	64	CRB-HT52	76600	19	CRHMK-S/S	62095	92
CBD-ST-HN-S/S	61100	150	CCKHDR-S/S	79231	66	CRB-HT58	76601	19	CRHMK-S/S	62095	105
CBD-ST-L	61050	150	CCKHDR-S/S	79231	74	CRB-HT64	76602	19	CST1HDM-B	78515	97
CBD-ST-L-B	64621	150	CCKHDS	79233	64	CRB-HT70	76603	19	CST1HDM-B-S/S	78392	99
CBD-ST-L-FP	61113	150	CCKHDS	79233	66	CRB-LS10	77088	14	CST1HDM-G	78516	97
CBD-ST-L-FR-B	A2218	150	CCKHDS	79233	74	CRB-LS10W	77097	14	CST1HDM-G-S/S	78393	99
CBD-ST-L-MF	61106	150	CCKHDS-S/S	73235	64	CRB-LS16	77089	14	CST1HDM-S	78514	97
CBD-ST-L-MF-S/S	61109	150	CCKHDS-S/S	73235	66	CRB-LS16HT	77552	14	CST1HDM-S-S/S	78391	99
CBD-ST-L-P	64773	150	CCKHDS-S/S	73235	74	CRB-LS16W	77098	14	CST1HDM-W	78513	97
CBD-ST-L-P-S/S	64624	150	CCKL	79224	64	CRB-LS22	77090	14	CST1HDM-W-S/S	78390	99
CBD-ST-L-PS	64777	150	CCKL	79224	66	CRB-LS22HT	77553	14	CSTAK	77031	97
CBD-ST-L-PS-S/S	64781	150	CCKL-S/S	79226	64	CRB-LS22W	77099	14	CSTAK	77031	99
CBD-ST-L-S	64785	150	CCKL-S/S	79226	66	CRB-LS28	77091	14	CSTBK	77037	97
CBD-ST-L-S/S	61080	150	CCKR	79228	64	CRB-LS28HT	77554	14	CSTBK	77037	99
CBD-ST-M	61077	150	CCKR	79228	66	CRB-LS28W	77100	14	CSTHDMK	77871	97
CBD-ST-M-FP	61112	150	CCKR-S/S	79230	64	CRB-LS34	77092	14	CSTHDMK-S/S	78384	99
CBD-ST-M-MF	61105	150	CCKR-S/S	79230	66	CRB-LS34HT	77555	14	CSTHDPM	77869	97
CBD-ST-M-MF-S/S	61108	150	CCKTS	79232	64	CRB-LS34W	77101	14	CSTHDPM-S/S	78389	99
CBD-ST-M-P	64772	150	CCKTS	79232	66	CRB-LS40	77093	14	CT6	74535	64
CBD-ST-M-P-S/S	64623	150	CCKTS-S/S	79234	64	CRB-LS40HT	77556	14	CT6	74535	66
CBD-ST-M-PS-S/S	64780	150	CCKTS-S/S	79234	66	CRB-LS40W	77102	14	CT6	74535	67
CBD-ST-M-PSS	64776	150	CCMK	78919	64	CRB-LS46	77094	14	CT6	74535	69
CBD-ST-M-S	64784	150	CCMK	78919	66	CRB-LS46HT	77557	14	CT6	74535	74
CBD-ST-M-S/S	61079	150	CCMK-S/S	78921	64	CRB-LS46W	77103	14	CT6	74535	76
CBD-ST-MC	B0092	150	CCMK-S/S	78921	66	CRB-LS52	77095	14	CT6	74535	83
CBD-ST-PB	A2449	150	CCMKHD	78920	64	CRB-LS52HT	77558	14	CT6	74535	85
CBD-ST-TB-S/S	A2629	150	CCMKHD	78920	66	CRB-LS52W	77104	14	CT6	74535	90
CBD-ST-XL	61051	150	CCMKHD	78920	74	CRB-LS58	77096	14	CT6	74535	92
CBD-ST-XL-B	64482	150	CCMKHD-S/S	78922	64	CRB-LS58HT	77559	14	CT6	74535	96
CBD-ST-XL-FP	61114	150	CCMKHD-S/S	78922	66	CRB-LS58W	77105	14	CT6	74535	99
CBD-ST-XL-FR-B	A1784	150	CCMKHD-S/S	78922	74	CRB-W16	78472	19	CT6 (C-Tip)	74535	80
CBD-ST-XL-MF	61107	150	CDS18	76684	117	CRB-W22	78473	19	CT6 (C-Tip)	74535	87
CBD-ST-XL-MF-S/S	61110	150	CDS24	76685	117	CRB-W28	78474	19	CT6 (C-Tip)	74535	94
CBD-ST-XL-P	64774	150	CDS30	76686	117	CRB-W34	78475	19	CTS-B	77744	97

INDEX By Ordering Number

Ordering Number	Item Code	Page #	Ordering Number	Item Code	Page #	Ordering Number	Item Code	Page #	Ordering Number	Item Code	Page #
CTS-B-S/S	78387	13	DRXL-36-435	76834	138	ESS-S	76412	110	EZCSK-900	82355	130
CTS-B-S/S	78387	99	DRXL-36-520	76826	138	ESS-S-S/S	79288	111	EZCSK-900	82355	132
CTS-G	77745	97	DRXL-36-535	76842	138	EST-B	76405	17	EZCSK-900	82355	134
CTS-G-S/S	78388	99	DRXL-42-420	76819	138	EST-G-S/S	78810	18	EZCSK-900	82355	136
CTS-S	77743	61	DRXL-42-435	76835	138	EST-P	76403	17	EZIB1050-1200L	82220	133
CTS-S	77743	97	DRXL-42-520	76827	138	EST-P-S/S	78808	18	EZIB1050-1200M	82236	135
CTS-S-S/S	78386	99	DRXL-42-535	76843	138	EST-S	76404	17	EZIB1050-1500L	82228	133
CTS-W	77742	97	DRXL-48-420	76820	138	EST-W-S/S	78809	18	EZIB1050-1500M	82244	135
CTS-W-S/S	78385	99	DRXL-48-435	76836	138	ESTAK	76406	17	EZIB1200-1200L	82221	133
DBK-L	76448	149	DRXL-48-520	76828	138	ESTAK	76406	110	EZIB1200-1200M	82237	135
DBK-M	76447	149	DRXL-48-535	76844	138	ESTAK-EST	76406	55	EZIB1200-1500L	82229	133
DBK-S	76446	149	DRXL-54-420	76821	138	ESTAK-EST-S/S	78849	18	EZIB1200-1500M	82245	135
DBK-XL	76449	149	DRXL-54-435	76837	138	ESTAK-EST-S/S	78849	55	EZIB1350-1200L	82222	133
DRXD-42-520	76912	141	DRXL-54-520	76829	138	ESTAK-SS	78849	111	EZIB1350-1200M	82238	135
DRXD-42-535	76919	141	DRXL-54-535	76845	138	EZAI-1050	82413	129	EZIB1350-1500L	82230	133
DRXD-48-520	76913	141	DRXL-60-420	76822	138	EZAI-1200	82414	129	EZIB1350-1500M	82246	135
DRXD-48-535	76920	141	DRXL-60-435	76838	138	EZAI-1350	82415	129	EZIB1500-1200L	82223	133
DRXD-54-520	76914	141	DRXL-60-520	76830	138	EZAI-1500	82416	129	EZIB1500-1200M	82239	135
DRXD-54-535	76921	141	DRXL-60-535	76846	138	EZAI-1800	82417	129	EZIB1500-1500L	82231	133
DRXD-60-520	76915	141	DRXL-72-420	76823	138	EZAI-600	82410	129	EZIB1500-1500M	82247	135
DRXD-60-535	76922	141	DRXL-72-435	76839	138	EZAI-750	82411	129	EZIB1800-1200L	82224	133
DRXD-72-520	76916	141	DRXL-72-520	76831	138	EZAI-900	82412	129	EZIB1800-1200M	82240	135
DRXD-72-535	76923	141	DRXL-72-535	76847	138	EZBMK-1050	82284	134	EZIB1800-1500L	82232	133
DRXD-84-520	76917	141	DRXM-24-420	76848	139	EZBMK-1050	82284	136	EZIB1800-1500M	82248	135
DRXD-84-535	76924	141	DRXM-24-435	76864	139	EZBMK-1200	82285	134	EZIB600-1200L	82217	133
DRXD-96-520	76918	141	DRXM-24-520	76856	139	EZBMK-1200	82285	136	EZIB600-1200M	82233	135
DRXD-96-535	76925	141	DRXM-24-535	76872	139	EZBMK-1350	82286	134	EZIB600-1500L	82225	133
DRXH-24-420	76880	140	DRXM-30-420	76849	139	EZBMK-1350	82286	136	EZIB600-1500M	82241	135
DRXH-24-435	76896	140	DRXM-30-435	76865	139	EZBMK-1500	82287	134	EZIB750-1200L	82218	133
DRXH-24-520	76888	140	DRXM-30-520	76857	139	EZBMK-1500	82287	136	EZIB750-1200M	82234	135
DRXH-24-535	76904	140	DRXM-30-535	76873	139	EZBMK-1800	82288	134	EZIB750-1500L	82226	133
DRXH-30-420	76881	140	DRXM-36-420	76850	139	EZBMK-1800	82288	136	EZIB750-1500M	82242	135
DRXH-30-435	76897	140	DRXM-36-435	76866	139	EZBMK-600	82281	134	EZIB900-1200L	82219	133
DRXH-30-520	76889	140	DRXM-36-520	76858	139	EZBMK-600	82281	136	EZIB900-1200M	82235	135
DRXH-30-535	76905	140	DRXM-36-535	76874	139	EZBMK-750	82282	134	EZIB900-1500L	82227	133
DRXH-36-420	76882	140	DRXM-42-420	76851	139	EZBMK-750	82282	136	EZIB900-1500M	82243	135
DRXH-36-435	76898	140	DRXM-42-435	76867	139	EZBMK-900	82283	136	EZP-LS212	77127	10
DRXH-36-520	76890	140	DRXM-42-520	76859	139	EZBMK-9000	82283	134	EZP-LS212-S/S	62836	10
DRXH-36-535	76906	140	DRXM-42-535	76875	139	EZBS-1200	82361	134	EZP-LS212HT	77746	10
DRXH-42-420	76883	140	DRXM-48-420	76852	139	EZBS-1500	82362	134	EZP-LS212HT-S/S	62845	10
DRXH-42-435	76899	140	DRXM-48-435	76868	139	EZCSK-1050	82356	130	EZP-LS218	77128	10
DRXH-42-520	76891	140	DRXM-48-520	76860	139	EZCSK-1050	82356	132	EZP-LS218-S/S	62837	10
DRXH-42-535	76907	140	DRXM-48-535	76876	139	EZCSK-1050	82356	134	EZP-LS218HT	77747	10
DRXH-48-420	76884	140	DRXM-54-420	76853	139	EZCSK-1050	82356	136	EZP-LS218HT-S/S	62846	10
DRXH-48-435	76900	140	DRXM-54-435	76869	139	EZCSK-1200	82357	130	EZP-LS218HT-S/S	62846	10
DRXH-48-520	76892	140	DRXM-54-520	76861	139	EZCSK-1200	82357	132	EZP-LS224	77129	10
DRXH-48-535	76908	140	DRXM-54-535	76877	139	EZCSK-1200	82357	134	EZP-LS224-S/S	62838	10
DRXH-54-420	76885	140	DRXM-60-420	76854	139	EZCSK-1200	82357	136	EZP-LS224HT-S/S	62847	10
DRXH-54-435	76901	140	DRXM-60-435	76870	139	EZCSK-1350	82358	130	EZP-LS230	77130	10
DRXH-54-520	76893	140	DRXM-60-520	76862	139	EZCSK-1350	82358	132	EZP-LS230-S/S	62839	10
DRXH-54-535	76909	140	DRXM-60-535	76878	139	EZCSK-1350	82358	134	EZP-LS230HT	77749	10
DRXH-60-420	76886	140	DRXM-72-420	76855	139	EZCSK-1350	82358	136	EZP-LS230HT-S/S	62848	10
DRXH-60-435	76902	140	DRXM-72-435	76871	139	EZCSK-1500	82359	130	EZP-LS236	77131	10
DRXH-60-520	76894	140	DRXM-72-520	76863	139	EZCSK-1500	82359	132	EZP-LS236-S/S	62840	10
DRXH-60-535	76910	140	DRXM-72-535	76879	139	EZCSK-1500	82359	134	EZP-LS236HT	77750	10
DRXH-72-420	76887	140	EBC-1	30001	169	EZCSK-1500	82359	136	EZP-LS236HT-S/S	62849	10
DRXH-72-435	76903	140	EBC-1-B	30003	169	EZCSK-1800	82360	130	EZP-LS242	77132	10
DRXH-72-520	76895	140	EBC-2	30002	169	EZCSK-1800	82360	132	EZP-LS242-S/S	62841	10
DRXH-72-535	76911	140	EBC-2-B	30004	169	EZCSK-1800	82360	134	EZP-LS242HT	77751	10
DRXL-24-420	76816	138	EBC1-RK	30033	169	EZCSK-1800	82360	136	EZP-LS242HT-S/S	62850	10
DRXL-24-435	76832	138	EBC2-RK	30034	169	EZCSK-600	82353	130	EZP-LS248	77133	10
DRXL-24-520	76824	138	ESBK-B	76411	17	EZCSK-600	82353	132	EZP-LS248-S/S	62842	10
DRXL-24-535	76840	138	ESBK-PS	76410	17	EZCSK-600	82353	134	EZP-LS248HT	77752	10
DRXL-30-420	76817	138	ESPBK	76408	17	EZCSK-600	82353	136	EZP-LS248HT-S/S	62851	10
DRXL-30-435	76833	138	ESPRK	76409	17	EZCSK-750	82354	130	EZP-LS254	77134	10
DRXL-30-520	76825	138	ESPSBK	76407	17	EZCSK-750	82354	132	EZP-LS254-S/S	62843	10
DRXL-30-535	76841	138	ESS-B	76413	17	EZCSK-750	82354	134	EZP-LS254HT	77753	10
DRXL-36-420	76818	138	ESS-S	76412	17	EZCSK-750	82354	136	EZP-LS254HT-S/S	62852	10

INDEX By Ordering Number

Ordering Number	Item Code	Page #	Ordering Number	Item Code	Page #	Ordering Number	Item Code	Page #	Ordering Number	Item Code	Page #
EZP-LS260	77135	10	EZP1T-272	78497	20	EZWPK-750	82346	132	FBP2500-2600-SP	61911	148
EZP-LS260-S/S	62844	10	EZPTBT	77384	21	EZWPK-750	82346	134	FBP2500-2600-SP-S/S	61919	148
EZP-LS260HT	77754	10	EZPTBTHD	77385	21	EZWPK-750	82346	136	FBP2500-B	61790	147
EZP-LS260HT-S/S	62853	10	EZPTCK	78508	21	EZWPK-900	82347	130	FBP2500-TP	61760	147
EZP1-218	75611	15	EZPTCKHD	78509	21	EZWPK-900	82347	132	FBP2500-TP S/S	61775	147
EZP1-218-S/S	61081	15	EZPTMPK	78507	21	EZWPK-900	82347	134	FBP2600-B	61791	147
EZP1-224	75612	15	EZPTSK	78511	21	EZWPK-900	82347	136	FBP2600-TP	61761	147
EZP1-224-S/S	61082	15	EZPTSKHD	78512	21	FBP-FP	61888	148	FBP2600-TP S/S	61776	147
EZP1-230	75613	15	EZPTSR	78510	21	FBP-FP-S/S	61889	148	FBP900-1050-MF	61795	148
EZP1-230-S/S	61017	15	EZRMKM	82344	130	FBP-LM	61882	148	FBP900-1050-MF-S/S	61803	148
EZP1-236	75614	15	EZRMKM	82344	132	FBP-LM-S/S	61883	148	FBP900-1050-PP	61890	148
EZP1-236-S/S	61083	15	EZSB1050-1200C	82188	129	FBP-NP	61875	148	FBP900-1050-PP-S/S	61898	148
EZP1-242	75615	15	EZSB1050-1200I	82204	131	FBP-NP-S/S	61876	148	FBP900-1050-SP	61906	148
EZP1-242-S/S	61016	15	EZSB1050-1500C	82196	129	FBP1050-B	61781	147	FBP900-1050-SP-S/S	61914	148
EZP1-248	75616	15	EZSB1050-1500I	82212	131	FBP1050-TP	61751	147	FBP900-B	61780	147
EZP1-248-S/S	61084	15	EZSB1200-1200C	82189	129	FBP1050-TP S/S	61766	147	FBP900-TP	61750	147
EZP1-254	75617	15	EZSB1200-1200I	82205	131	FBP1200-1400-MF	61796	148	FBP900-TP S/S	61765	147
EZP1-254-S/S	61085	15	EZSB1200-1500C	82197	129	FBP1200-1400-MF-S/S	61804	148	FL-L	76980	169
EZP1-260	75618	15	EZSB1200-1500I	82213	131	FBP1200-1400-PP	61891	148	FL-M	76979	169
EZP1-260-S/S	61086	15	EZSB1350-1200C	82190	129	FBP1200-1400-PP-S/S	61899	148	FL-XL	76983	169
EZP1-272	75771	15	EZSB1350-1200I	82206	131	FBP1200-1400-SP	61907	148	FLCP	76479	169
EZP1-272-S/S	61087	15	EZSB1350-1500C	82198	129	FBP1200-1400-SP-S/S	61915	148	FLEL-L	76473	169
EZP1BP	75642	17	EZSB1350-1500I	82214	131	FBP1200-B	61782	147	FLEL-M	76472	169
EZP1BP	75642	21	EZSB1500-1200C	82191	129	FBP1200-TP	61752	147	FLELK-XL	76986	169
EZP1MPK	75637	17	EZSB1500-1200I	82207	131	FBP1200-TP S/S	61767	147	FLELP	76474	169
EZP1MPK-S/S	78923	18	EZSB1500-1500C	82199	129	FBP1400-B	61783	147	FLRLB-L	76481	169
EZP1P12	75619	17	EZSB1500-1500I	82215	131	FBP1400-TP	61753	147	FLRLB-M	76482	169
EZP1P12	75619	21	EZSB1800-1200C	82192	129	FBP1400-TP S/S	61768	147	FLRP	76478	169
EZP1P12-S/S	78812	18	EZSB1800-1200I	82208	131	FBP1500-1600-MF	61797	148	FLSC-CP	71057	166
EZP1P18	75620	17	EZSB1800-1500C	82200	129	FBP1500-1600-MF-S/S	61805	148	FLSC-CP-S/S	A1438	166
EZP1P18	75620	21	EZSB1800-1500I	82216	131	FBP1500-1600-PP	61892	148	FLSC-TP	71056	166
EZP1P18-S/S	61182	18	EZSB600-1200C	82185	129	FBP1500-1600-PP-S/S	61900	148	FLSC-TP-S/S	A1437	166
EZP1P24	75621	17	EZSB600-1200I	82201	131	FBP1500-1600-SP	61908	148	FLSC2000	71053	166
EZP1P24	75621	21	EZSB600-1500C	82193	129	FBP1500-1600-SP-S/S	61916	148	FLSC2000-CB	71061	166
EZP1P24-S/S	A2988	18	EZSB600-1500I	82209	131	FBP1500-B	61784	147	FLSC2000-CB-S/S	A1439	166
EZP1P30	75622	17	EZSB750-1200C	82186	129	FBP1500-TP	61754	147	FLSC2000-MC	71059	166
EZP1P30	75622	21	EZSB750-1200I	82202	131	FBP1500-TP S/S	61769	147	FLSC2000-MC-S/S	A1440	166
EZP1P30-S/S	A3041	18	EZSB750-1500C	82194	129	FBP1600-B	61785	147	FLSC2000-S/S	A1436	166
EZP1P36	75623	17	EZSB750-1500I	82210	131	FBP1600-TP	61755	147	FLSCM-CP	71140	166
EZP1P36	75623	21	EZSB900-1200C	82187	129	FBP1600-TP S/S	61770	147	FLSCM-CP-S/S	A2596	166
EZP1P36-S/S	A3119	18	EZSB900-1200I	82203	131	FBP1800-2000-MF	61798	148	FLSCM2000	71148	166
EZP1P42	75624	17	EZSB900-1500C	82195	129	FBP1800-2000-MF-S/S	61806	148	FLSCM2000-S/S	61471	166
EZP1P42	75624	21	EZSB900-1500I	82211	131	FBP1800-2000-PP	61893	148	FLTW-L	76477	169
EZP1P42-S/S	61183	18	EZWPK-1050	82348	130	FBP1800-2000-PP-S/S	61901	148	FLTW-M	76476	169
EZP1P48	75625	17	EZWPK-1050	82348	132	FBP1800-2000-SP	61909	148	FLTW-XL	76985	169
EZP1P48	75625	21	EZWPK-1050	82348	134	FBP1800-2000-SP-S/S	61917	148	FLVRL-XL	76984	169
EZP1P48-S/S	61491	18	EZWPK-1050	82348	136	FBP1800-B	61786	147	FMS-1050-EL15	65663	67
EZP1P54	75626	17	EZWPK-1200	82349	130	FBP1800-TP	61756	147	FMS-1050-EL15-S/S	65673	67
EZP1P54	75626	21	EZWPK-1200	82349	132	FBP1800-TP S/S	61771	147	FMS-1050V	79650	67
EZP1P54-S/S	61184	18	EZWPK-1200	82349	134	FBP2000-B	61787	147	FMS-1050V-S/S	79650	67
EZP1P60	75627	17	EZWPK-1200	82349	136	FBP2000-TP	61757	147	FMS-1200-EL15	65664	67
EZP1P60	75627	21	EZWPK-1350	82350	130	FBP2000-TP S/S	61772	147	FMS-1200-EL15-S/S	65674	67
EZP1P60-S/S	61185	18	EZWPK-1350	82350	134	FBP2200-2400-MF	61799	148	FMS-1200V	79651	67
EZP1P72	75772	17	EZWPK-1350	82350	136	FBP2200-2400-MF-S/S	61807	148	FMS-1200V-S/S	79651	67
EZP1P72	75772	21	EZWPK-13500	82350	132	FBP2200-2400-PP	61894	148	FMS-1350-EL15	65665	67
EZP1P72-S/S	61186	18	EZWPK-1500	82351	130	FBP2200-2400-PP-S/S	61902	148	FMS-1350-EL15-S/S	65675	67
EZP1PL	75641	17	EZWPK-1500	82351	132	FBP2200-2400-SP	61910	148	FMS-1350V	79652	67
EZP1PL	75641	21	EZWPK-1500	82351	134	FBP2200-2400-SP-S/S	61918	148	FMS-1350V-S/S	79652	67
EZP1PL-S/S	78848	18	EZWPK-1500	82351	136	FBP2200-B	61788	147	FMS-1500-EL15	65666	67
EZP1T-212	78488	20	EZWPK-1800	82352	130	FBP2200-TP	61758	147	FMS-1500-EL15-S/S	65676	67
EZP1T-218	78489	20	EZWPK-1800	82352	132	FBP2200-TP S/S	61773	147	FMS-1500V	79653	67
EZP1T-224	78490	20	EZWPK-1800	82352	134	FBP2400-B	61789	147	FMS-1500V-S/S	79653	67
EZP1T-230	78491	20	EZWPK-1800	82352	136	FBP2400-TP	61759	147	FMS-1800-EL15	65667	67
EZP1T-236	78492	20	EZWPK-600	82345	130	FBP2400-TP S/S	61774	147	FMS-1800-EL15-S/S	65677	67
EZP1T-242	78493	20	EZWPK-600	82345	132	FBP2500-2600-MF	61800	148	FMS-1800V	79654	67
EZP1T-248	78494	20	EZWPK-600	82345	134	FBP2500-2600-MF-S/S	61808	148	FMS-1800V-S/S	79654	67
EZP1T-254	78495	20	EZWPK-600	82345	136	FBP2500-2600-PP	61895	148	FMS-2100-EL15	65668	67
EZP1T-260	78496	20	EZWPK-750	82346	130	FBP2500-2600-PP-S/S	61903	148	FMS-2100-EL15-S/S	65678	67

INDEX By Ordering Number

Ordering Number	Item Code	Page #	Ordering Number	Item Code	Page #	Ordering Number	Item Code	Page #	Ordering Number	Item Code	Page #
FMS-2100V	65680	67	H-CARK-1200-CL	62547	44	H-CARK2-1600-CL	62608	44	H-CARK2-2600-CM	62622	44
FMS-2100V-S/S	65682	67	H-CARK-1200-CL-EL15	63642	50	H-CARK2-1600-CL-EL15	63576	50	H-CARK2-2600-CM-EL15	63590	50
FMS-2400-EL15	65669	67	H-CARK-1200-CM	62546	44	H-CARK2-1600-CL-S/S	62714	46	H-CARK2-2600-CM-S/S	62728	46
FMS-2400-EL15-S/S	65679	67	H-CARK-1200-CM-EL15	63641	50	H-CARK2-1600-CL-S/S-EL15	63608	52	H-CARK2-2600-CM-S/S-EL15	63622	52
FMS-2400V	65681	67	H-CARK-1200-CS	62545	44	H-CARK2-1600-CLL	62609	44	H-CARK2-2800-CL	62626	44
FMS-2400V-S/S	65683	67	H-CARK-1200-CS-EL15	63640	50	H-CARK2-1600-CLL-EL15	63577	50	H-CARK2-2800-CL-EL15	63594	50
FMS-600-EL15	65660	67	H-CARK-1400-CL	62550	44	H-CARK2-1600-CLL-S/S	62715	46	H-CARK2-2800-CL-S/S	62732	46
FMS-600-EL15-S/S	65670	67	H-CARK-1400-CL-EL15	63645	50	H-CARK2-1600-CLL-S/S-EL15	63609	52	H-CARK2-2800-CL-S/S-EL15	63626	52
FMS-600V	79647	67	H-CARK-1400-CM	62549	44	H-CARK2-1600-CM	62607	44	H-CARK2-2800-CLL	62627	44
FMS-600V-S/S	79647	67	H-CARK-1400-CM-EL15	63644	50	H-CARK2-1600-CM-EL15	63575	50	H-CARK2-2800-CLL-EL15	63595	50
FMS-750-EL15	65661	67	H-CARK-1400-CS	62548	44	H-CARK2-1600-CM-S/S	62713	46	H-CARK2-2800-CLL-S/S	62733	46
FMS-750-EL15-S/S	65671	67	H-CARK-1400-CS-EL15	63643	50	H-CARK2-1600-CM-S/S-EL15	63607	52	H-CARK2-2800-CLL-S/S-EL15	63627	52
FMS-750V	79648	67	H-CARK-1600-CL	62553	44	H-CARK2-1800-CL	62611	44	H-CARK2-2800-CM	62625	44
FMS-750V-S/S	79648	67	H-CARK-1600-CL-EL15	63648	50	H-CARK2-1800-CL-EL15	63579	50	H-CARK2-2800-CM-EL15	63593	50
FMS-900-EL15	65662	67	H-CARK-1600-CM	62552	44	H-CARK2-1800-CL-S/S	62717	46	H-CARK2-2800-CM-S/S	62731	46
FMS-900-EL15-S/S	65672	67	H-CARK-1600-CM-EL15	63647	50	H-CARK2-1800-CL-S/S-EL15	63611	52	H-CARK2-2800-CM-S/S-EL15	63625	52
FMS-900V	79649	67	H-CARK-1600-CS	62551	44	H-CARK2-1800-CLL	62612	44	H-CARK2-3000-CL	62629	44
FMS-900V-S/S	79649	67	H-CARK-1600-CS-EL15	63646	50	H-CARK2-1800-CLL-EL15	63580	50	H-CARK2-3000-CL-EL15	63597	50
FMSC	79699	69	H-CARK-1800-CL	62556	44	H-CARK2-1800-CLL-S/S	62718	46	H-CARK2-3000-CL-S/S	62735	46
FMSC	79699	69	H-CARK-1800-CL-EL15	63651	50	H-CARK2-1800-CLL-S/S-EL15	63612	52	H-CARK2-3000-CL-S/S-EL15	63629	52
H CARK-1000-CL-S/S	62660	46	H-CARK-1800-CM	62555	44	H-CARK2-1800-CM	62610	44	H-CARK2-3000-CLL	62630	44
H CARK-1000-CL-S/S-EL15	63660	52	H-CARK-1800-CM-EL15	63650	50	H-CARK2-1800-CM-EL15	63578	50	H-CARK2-3000-CLL-EL15	63598	50
H CARK-1000-CM-S/S	62659	46	H-CARK-1800-CS	62554	44	H-CARK2-1800-CM-S/S	62716	46	H-CARK2-3000-CLL-S/S	62736	46
H CARK-1000-CM-S/S-EL15	63659	52	H-CARK-1800-CS-EL15	63649	50	H-CARK2-1800-CM-S/S-EL15	63610	52	H-CARK2-3000-CLL-S/S-EL15	63630	52
H CARK-1000-CS-S/S	62658	46	H-CARK-600-CL	62538	44	H-CARK2-2000-CL	62614	44	H-CARK2-3000-CM	62628	44
H CARK-1000-CS-S/S-EL15	63658	52	H-CARK-600-CL-EL15	63633	50	H-CARK2-2000-CL-EL15	63582	50	H-CARK2-3000-CM-EL15	63596	50
H CARK-1200-CL-S/S	62663	46	H-CARK-600-CM	62537	44	H-CARK2-2000-CL-S/S	62720	46	H-CARK2-3000-CM-S/S	62734	46
H CARK-1200-CL-S/S-EL15	63663	52	H-CARK-600-CM-EL15	63632	50	H-CARK2-2000-CL-S/S-EL15	63614	52	H-CARK2-3000-CM-S/S-EL15	63628	52
H CARK-1200-CM-S/S	62662	46	H-CARK-600-CS	62536	44	H-CARK2-2000-CLL	62615	44	H-SAC-AP-1000	62454	47
H CARK-1200-CM-S/S-EL15	63662	52	H-CARK-600-CS-EL15	63631	50	H-CARK2-2000-CLL-EL15	63583	50	H-SAC-AP-1000	62454	48
H CARK-1200-CS-S/S	62661	46	H-CARK-800-CL	62541	44	H-CARK2-2000-CLL-S/S	62721	46	H-SAC-AP-1000	62454	48
H CARK-1200-CS-S/S-EL15	63661	52	H-CARK-800-CL-EL15	63636	50	H-CARK2-2000-CLL-S/S-EL15	63615	52	H-SAC-AP-1000	62454	48
H CARK-1400-CL-S/S	62666	46	H-CARK-800-CM	62540	44	H-CARK2-2000-CM	62613	44	H-SAC-AP-1000	62454	48
H CARK-1400-CL-S/S-EL15	63666	52	H-CARK-800-CM-EL15	63635	50	H-CARK2-2000-CM-EL15	63581	50	H-SAC-AP-1000	62454	53
H CARK-1400-CM-S/S	62665	46	H-CARK-800-CS	62539	44	H-CARK2-2000-CM-S/S	62719	46	H-SAC-AP-1000	62454	54
H CARK-1400-CM-S/S-EL15	63665	52	H-CARK-800-CS-EL15	63634	50	H-CARK2-2000-CM-S/S-EL15	63613	52	H-SAC-AP-1000	62454	54
H CARK-1400-CS-S/S	62664	46	H-CARK2-1200-CL	62601	44	H-CARK2-2200-CL	62617	44	H-SAC-AP-1000	62454	54
H CARK-1400-CS-S/S-EL15	63664	52	H-CARK2-1200-CL-EL15	63569	50	H-CARK2-2200-CL-EL15	63585	50	H-SAC-AP-1000	62454	54
H CARK-1600-CL-S/S	62669	46	H-CARK2-1200-CL-S/S	62707	46	H-CARK2-2200-CL-S/S	62723	46	H-SAC-AP-1200	62455	47
H CARK-1600-CL-S/S-EL15	63669	52	H-CARK2-1200-CL-S/S-EL15	63601	52	H-CARK2-2200-CL-S/S-EL15	63617	52	H-SAC-AP-1200	62455	48
H CARK-1600-CM-S/S	62668	46	H-CARK2-1200-CLL	62602	44	H-CARK2-2200-CLL	62618	44	H-SAC-AP-1200	62455	48
H CARK-1600-CM-S/S-EL15	63668	52	H-CARK2-1200-CLL-EL15	63570	50	H-CARK2-2200-CLL-EL15	63586	50	H-SAC-AP-1200	62455	48
H CARK-1600-CS-S/S	62667	46	H-CARK2-1200-CLL-S/S	62708	46	H-CARK2-2200-CLL-S/S	62724	46	H-SAC-AP-1200	62455	48
H CARK-1600-CS-S/S-EL15	63667	52	H-CARK2-1200-CLL-S/S-EL15	63602	52	H-CARK2-2200-CLL-S/S-EL15	63618	52	H-SAC-AP-1200	62455	53
H CARK-1800-CL-S/S	62672	46	H-CARK2-1200-CM	62600	44	H-CARK2-2200-CM	62616	44	H-SAC-AP-1200	62455	54
H CARK-1800-CL-S/S-EL15	63672	52	H-CARK2-1200-CM-EL15	63568	50	H-CARK2-2200-CM-EL15	63584	50	H-SAC-AP-1200	62455	54
H CARK-1800-CM-S/S	62671	46	H-CARK2-1200-CM-S/S	62706	46	H-CARK2-2200-CM-S/S	62722	46	H-SAC-AP-1200	62455	54
H CARK-1800-CM-S/S-EL15	63671	52	H-CARK2-1200-CM-S/S-EL15	63600	52	H-CARK2-2200-CM-S/S-EL15	63616	52	H-SAC-AP-1200	62455	54
H CARK-1800-CS-S/S	62670	46	H-CARK2-1200-CS	62599	44	H-CARK2-2400-CL	62620	44	H-SAC-AP-1400	62456	47
H CARK-1800-CS-S/S-EL15	63670	52	H-CARK2-1200-CS-EL15	63567	50	H-CARK2-2400-CL-EL15	63588	50	H-SAC-AP-1400	62456	48
H CARK-600-CL-S/S	62654	46	H-CARK2-1200-CS-S/S	62705	46	H-CARK2-2400-CL-S/S	62726	46	H-SAC-AP-1400	62456	48
H CARK-600-CL-S/S-EL15	63654	52	H-CARK2-1200-CS-S/S-EL15	63599	52	H-CARK2-2400-CL-S/S-EL15	63620	52	H-SAC-AP-1400	62456	48
H CARK-600-CM-S/S	62653	46	H-CARK2-1400-CL	62605	44	H-CARK2-2400-CLL	62621	44	H-SAC-AP-1400	62456	48
H CARK-600-CM-S/S-EL15	63653	52	H-CARK2-1400-CL-EL15	63573	50	H-CARK2-2400-CLL-EL15	63589	50	H-SAC-AP-1400	62456	53
H CARK-600-CS-S/S	62652	46	H-CARK2-1400-CL-S/S	62711	46	H-CARK2-2400-CLL-S/S	62727	46	H-SAC-AP-1400	62456	54
H CARK-600-CS-S/S-EL15	63652	52	H-CARK2-1400-CL-S/S-EL15	63605	52	H-CARK2-2400-CLL-S/S-EL15	63621	52	H-SAC-AP-1400	62456	54
H CARK-800-CL-S/S	62657	46	H-CARK2-1400-CLL	62606	44	H-CARK2-2400-CM	62619	44	H-SAC-AP-1400	62456	54
H CARK-800-CL-S/S-EL15	63657	52	H-CARK2-1400-CLL-EL15	63574	50	H-CARK2-2400-CM-EL15	63587	50	H-SAC-AP-1400	62456	54
H CARK-800-CM-S/S	62656	46	H-CARK2-1400-CLL-S/S	62712	46	H-CARK2-2400-CM-S/S	62725	46	H-SAC-AP-1600	62457	47
H CARK-800-CM-S/S-EL15	63656	52	H-CARK2-1400-CLL-S/S-EL15	63606	52	H-CARK2-2400-CM-S/S-EL15	63619	52	H-SAC-AP-1600	62457	48
H CARK-800-CS-S/S	62655	46	H-CARK2-1400-CM	62604	44	H-CARK2-2600-CL	62623	44	H-SAC-AP-1600	62457	53
H CARK-800-CS-S/S-EL15	63655	52	H-CARK2-1400-CM-EL15	63572	50	H-CARK2-2600-CL-EL15	63591	50	H-SAC-AP-1600	62457	54
H-CARK-1000-CL	62544	44	H-CARK2-1400-CM-S/S	62710	46	H-CARK2-2600-CL-S/S	62729	46	H-SAC-AP-1800	62458	47
H-CARK-1000-CL-EL15	63639	50	H-CARK2-1400-CM-S/S-EL15	63604	52	H-CARK2-2600-CL-S/S-EL15	63623	52	H-SAC-AP-1800	62458	53
H-CARK-1000-CM	62543	44	H-CARK2-1400-CS	62603	44	H-CARK2-2600-CLL	62624	44	H-SAC-AP-600	62452	47
H-CARK-1000-CM-EL15	63638	50	H-CARK2-1400-CS-EL15	63571	50	H-CARK2-2600-CLL-EL15	63592	50	H-SAC-AP-600	62452	48
H-CARK-1000-CS	62542	44	H-CARK2-1400-CS-S/S	62709	46	H-CARK2-2600-CLL-S/S	62730	46	H-SAC-AP-600	62452	48
H-CARK-1000-CS-EL15	63637	50	H-CARK2-1400-CS-S/S-EL15	63603	52	H-CARK2-2600-CLL-S/S-EL15	63624	52	H-SAC-AP-600	62452	48



INDEX By Ordering Number

Ordering Number	Item Code	Page #	Ordering Number	Item Code	Page #	Ordering Number	Item Code	Page #	Ordering Number	Item Code	Page #
H-SAC-AP-600	62452	53	H73CSK-B-S/S	62750	42	HBP1400-PL-TP	A2297	148	HBP900-PL-TP-S/S	A2492	148
H-SAC-AP-600	62452	54	H73CSK-B-S/S	62750	47	HBP1400-PL-TP-S/S	A2495	146	HBP900-TP	A2283	145
H-SAC-AP-600	62452	54	H73CSK-B-S/S	62750	48	HBP1400-PL-TP-S/S	A2495	148	HBRK	73068	42
H-SAC-AP-600	62452	54	H73CSK-B-S/S	62750	53	HBP1400-TP	A2286	145	HBRK-S/S	75422	42
H-SAC-AP-800	62453	47	H73CSK-B-S/S	62750	54	HBP1500-B-TP	A2320	146	HBRK-S/S -73	76246	55
H-SAC-AP-800	62453	48	H73CSK-B-S/S	62750	55	HBP1500-MF-TP	A2309	146	HBRK-S/S-60	75422	55
H-SAC-AP-800	62453	48	H73CSK-G	62743	42	HBP1500-MF-TP-S/S	A2508	146	HBRKX	74549	42
H-SAC-AP-800	62453	48	H73CSK-G	62743	47	HBP1500-PL-TP	A2298	146	HBRKX-S/S	76246	42
H-SAC-AP-800	62453	48	H73CSK-G	62743	48	HBP1500-PL-TP	A2298	148	HCP-1000	62753	47
H-SAC-AP-800	62453	53	H73CSK-G	62743	53	HBP1500-PL-TP-S/S	A2496	146	HCP-1000	62753	53
H-SAC-AP-800	62453	54	H73CSK-G	62743	54	HBP1500-PL-TP-S/S	A2496	148	HCP-1000-S/S	62759	47
H-SAC-AP-800	62453	54	H73CSK-G	62743	55	HBP1500-TP	A2287	145	HCP-1000-S/S	62759	53
H-SAC-AP-800	62453	54	H73CSK-G-S/S	62744	42	HBP1600-B-TP	A2321	146	HCP-1200	62754	47
H-SAC-AP-800	62453	54	H73CSK-G-S/S	62744	47	HBP1600-MF-TP	A2310	146	HCP-1200	62754	53
H2CP-1200	62763	48	H73CSK-G-S/S	62744	48	HBP1600-MF-TP-S/S	A2509	146	HCP-1200-S/S	62760	47
H2CP-1200	62763	54	H73CSK-G-S/S	62744	53	HBP1600-PL-TP	A2299	146	HCP-1200-S/S	62760	53
H2CP-1200-S/S	62801	48	H73CSK-G-S/S	62744	54	HBP1600-PL-TP	A2299	148	HCP-1400	62755	47
H2CP-1200-S/S	62801	54	H73CSK-G-S/S	62744	55	HBP1600-PL-TP-S/S	A2497	146	HCP-1400	62755	53
H2CP-1400	62764	48	H73CSK-S	62745	48	HBP1600-PL-TP-S/S	A2497	148	HCP-1400-S/S	62761	47
H2CP-1400	62764	54	H73CSK-S	62745	54	HBP1600-TP	A2288	145	HCP-1400-S/S	62761	53
H2CP-1400-S/S	62802	48	H73CSK-S	62745	55	HBP1800-B-TP	A2322	146	HCP-1800	62756	47
H2CP-1400-S/S	62802	54	H73CSK-S-S/S	62746	48	HBP1800-MF-TP	A2311	146	HCP-1800	62756	53
H2CP-1600	62765	48	H73CSK-S-S/S	62746	54	HBP1800-MF-TP-S/S	A2510	146	HCP-1800-S/S	62762	47
H2CP-1600	62765	54	H73CSK-S-S/S	62746	55	HBP1800-PL-TP	A2300	146	HCP-1800-S/S	62762	53
H2CP-1600-S/S	62803	48	HARK	73069	42	HBP1800-PL-TP	A2300	148	HCP-600	62751	47
H2CP-1600-S/S	62803	54	HARK	73069	110	HBP1800-PL-TP-S/S	A2498	146	HCP-600	62751	53
H2CP-1800	62766	48	HARK-S/S	75423	42	HBP1800-PL-TP-S/S	A2498	148	HCP-600-S/S	62757	47
H2CP-1800	62766	54	HARK-S/S	77364	111	HBP1800-TP	A2289	145	HCP-600-S/S	62757	53
H2CP-1800-S/S	62804	48	HATDMK-S/S	63861	55	HBP2000-B-TP	A2323	146	HCP-800	62752	47
H2CP-1800-S/S	62804	54	HBP-LA-TP	A2330	146	HBP2000-MF-TP	A2312	146	HCP-800	62752	53
H2CP-2000	62767	48	HBP-LA-TP-S/S	A2515	146	HBP2000-MF-TP-S/S	A2511	146	HCP-800-S/S	62758	47
H2CP-2000	62767	54	HBP-MB-TP	73922	146	HBP2000-PL-TP	A2301	146	HCP-800-S/S	62758	53
H2CP-2000-S/S	62805	48	HBP-MB-TP	73922	148	HBP2000-PL-TP	A2301	148	HCSBB-60	62513	55
H2CP-2000-S/S	62805	54	HBP-MB-TP-S/S	A1155	146	HBP2000-PL-TP-S/S	A2499	146	HCSBB-60	62513	55
H2CP-2400	62768	48	HBP-MB-TP-S/S	A1155	148	HBP2000-PL-TP-S/S	A2499	148	HCSBB-73	62514	55
H2CP-2400	62768	54	HBP-SC-TP	74490	146	HBP2000-TP	A2290	145	HCSBB-73	62514	55
H2CP-2400-S/S	62806	48	HBP-SC-TP-S/S	A2189	146	HBP2200-B-TP	A2325	146	HCSSB-B/G	62589	55
H2CP-2400-S/S	62806	54	HBP-TP-1050 S/S	A2475	145	HBP2200-MF-TP	A2314	146	HCSSB-B/G	62589	55
H2CP-2600	62769	48	HBP-TP-1200 S/S	A2476	145	HBP2200-MF-TP-S/S	A2512	146	HCSSB-B/G	62589	55
H2CP-2600	62769	54	HBP-TP-1400 S/S	A2477	145	HBP2200-PL-TP	A2303	146	HCSSB-B/G	62589	55
H2CP-2600-S/S	62807	48	HBP-TP-1500 S/S	A2478	145	HBP2200-PL-TP	A2303	148	HCSSB-S	62590	55
H2CP-2600-S/S	62807	54	HBP-TP-1600 S/S	A2479	145	HBP2200-PL-TP-S/S	A2500	146	HCSSB-S	62590	55
H2CP-2800	62770	48	HBP-TP-1800 S/S	A2480	145	HBP2200-PL-TP-S/S	A2500	148	HCSTAK	62494	55
H2CP-2800	62770	54	HBP-TP-2000 S/S	A2481	145	HBP2200-TP	A2291	145	HCSTAK-S/S	62495	55
H2CP-2800-S/S	62808	48	HBP-TP-2200 S/S	A2482	145	HBP2400-B-TP	A2324	146	HCSTK-60-B	62747	42
H2CP-2800-S/S	62808	54	HBP-TP-2400 S/S	A2483	145	HBP2400-MF-TP	A2313	146	HCSTK-60-B-S/S	62748	42
H2CP-3000	62771	48	HBP-TP-2500 S/S	A2484	145	HBP2400-MF-TP-S/S	A2513	146	HCSTK-60-G	62741	42
H2CP-3000	62771	54	HBP-TP-900 S/S	A2474	145	HBP2400-PL-TP	A2302	146	HCSTK-60-G-S/S	62742	42
H2CP-3000-S/S	62809	48	HBP1050-B-TP	A2317	146	HBP2400-PL-TP	A2302	148	HDARK	74550	42
H2CP-3000-S/S	62809	54	HBP1050-MF-TP	A2306	146	HBP2400-PL-TP-S/S	A2501	146	HDARK	77329	110
H60CSK-B	62747	55	HBP1050-MF-TP-S/S	A2505	146	HBP2400-PL-TP-S/S	A2501	148	HDARK-S/S	76247	42
H60CSK-B-S/S	62748	55	HBP1050-PL-TP	A2295	146	HBP2400-TP	A2292	145	HDARK-S/S	77331	111
H60CSK-G	62741	55	HBP1050-PL-TP	A2295	148	HBP2500-B-TP	A2326	146	HDATDMK-S/S	63862	55
H60CSK-G-S/S	62742	55	HBP1050-PL-TP-S/S	A2493	146	HBP2500-MF-TP	A2315	146	HDCK	74490	42
H73BTK	63079	47	HBP1050-PL-TP-S/S	A2493	148	HBP2500-MF-TP-S/S	A2514	146	HDMK	74551	42
H73BTK	63079	48	HBP1050-TP	A2284	145	HBP2500-PL-TP	A2304	146	HDMK-S/S	76248	42
H73BTK	63079	53	HBP1200-B-TP	A2318	146	HBP2500-PL-TP	A2304	148	HDMRK	74582	42
H73BTK	63079	54	HBP1200-MF-TP	A2307	146	HBP2500-PL-TP-S/S	A2502	146	HDMRK	74582	42
H73BTK-S/S	63080	47	HBP1200-MF-TP-S/S	A2506	146	HBP2500-PL-TP-S/S	A2502	148	HDMRK-S/S	76245	42
H73BTK-S/S	63080	48	HBP1200-PL-TP	A2296	146	HBP2500-TP	A2293	145	HDMRK-S/S	76245	42
H73BTK-S/S	63080	53	HBP1200-PL-TP	A2296	148	HBP2600-PL-TP	A0151	148	HDPTEZUG-1050	90798	153
H73BTK-S/S	63080	54	HBP1200-PL-TP-S/S	A2494	146	HBP2600-PL-TP-S/S	61877	148	HDPTEZUG-1200	90799	153
H73CSK-B	62749	42	HBP1200-PL-TP-S/S	A2494	148	HBP900-B-TP	A2316	146	HDPTEZUG-1350	90800	153
H73CSK-B	62749	47	HBP1200-TP	A2285	145	HBP900-MF-TP	A2305	146	HDPTEZUG-1500	90801	153
H73CSK-B	62749	48	HBP1400-B-TP	A2319	146	HBP900-MF-TP-S/S	A2504	146	HDPTEZUG-1800	90802	153
H73CSK-B	62749	53	HBP1400-MF-TP	A2308	146	HBP900-PL-TP	A2294	146	HDR24	79010	124
H73CSK-B	62749	54	HBP1400-MF-TP-S/S	A2507	146	HBP900-PL-TP	A2294	148	HDR30	79011	124
H73CSK-B	62749	55	HBP1400-PL-TP	A2297	146	HBP900-PL-TP-S/S	A2492	146	HDR36	79012	124

INDEX By Ordering Number

Ordering Number	Item Code	Page #	Ordering Number	Item Code	Page #	Ordering Number	Item Code	Page #	Ordering Number	Item Code	Page #
HDR42	79013	124	HSA8CL	62507	47	HSA8SSS	75565	41	HV-1200-SAC-CM-S/S-EL15	63237	51
HDR48	79014	124	HSA8CL	62507	48	HSHD	73483	42	HV-1200-SAC-CS	62524	43
HDR54	79015	124	HSA8CL	62507	49	HSHD	73483	47	HV-1200-SAC-CS-EL15	63215	49
HDR60	79016	124	HSA8CL	62507	53	HSHD	73483	48	HV-1200-SAC-CS-S/S	62640	45
HDRBK	79009	124	HSA8CL	62507	54	HSHD	73483	53	HV-1200-SAC-CS-S/S-EL15	63236	51
HDRBK-HD	79072	124	HSA8CL-S/S	62511	45	HSHD	73483	54	HV-1400-2SAC-CL	62563	43
HDRGEK	79236	124	HSA8CL-S/S	62511	47	HSHD-S/S	76467	42	HV-1400-2SAC-CL-EL15	63427	49
HDRP17	63679	126	HSA8CL-S/S	62511	48	HSHD-S/S	76467	47	HV-1400-2SAC-CL-S/S	62679	45
HDRP22	63678	126	HSA8CL-S/S	62511	51	HSHD-S/S	76467	48	HV-1400-2SAC-CL-S/S-EL15	63459	51
HDRR24	79019	124	HSA8CL-S/S	62511	53	HSHD-S/S	76467	53	HV-1400-2SAC-CLL	62564	43
HDRR30	79020	124	HSA8CL-S/S	62511	54	HSHD-S/S	76467	54	HV-1400-2SAC-CLL-EL15	63428	49
HDRR36	79021	124	HSA8CLL	62508	43	HSTSS	61173	42	HV-1400-2SAC-CLL-S/S	62680	45
HDRR42	79022	124	HSA8CLL	62508	47	HTF212	76658	15	HV-1400-2SAC-CLL-S/S-EL15	63460	51
HDRR48	79023	124	HSA8CLL	62508	48	HTF212-S/S	62826	15	HV-1400-2SAC-CM	62562	43
HDRR54	79024	124	HSA8CLL	62508	49	HTF218	76659	15	HV-1400-2SAC-CM-EL15	63426	49
HDRR60	79025	124	HSA8CLL	62508	53	HTF218-S/S	62827	15	HV-1400-2SAC-CM-S/S	62678	45
HDRRS72*	79026	124	HSA8CLL	62508	54	HTF224	76660	15	HV-1400-2SAC-CM-S/S-EL15	63458	51
HDRRS84*	79027	124	HSA8CLL-S/S	62512	45	HTF224-S/S	62828	15	HV-1400-2SAC-CS	62561	43
HDRS72*	79017	124	HSA8CLL-S/S	62512	47	HTF230	76661	15	HV-1400-2SAC-CS-EL15	63425	49
HDRS84*	79018	124	HSA8CLL-S/S	62512	48	HTF230-S/S	62829	15	HV-1400-2SAC-CS-S/S	62677	45
HDSTCK-S/S	A2189	42	HSA8CLL-S/S	62512	51	HTF236	76662	15	HV-1400-2SAC-CS-S/S-EL15	63457	51
HDSTKD	A2518	42	HSA8CLL-S/S	62512	53	HTF236-S/S	62830	15	HV-1400-SAC-CL	62529	43
HDSTKD-S/S	A2519	42	HSA8CLL-S/S	62512	54	HTF242	76663	15	HV-1400-SAC-CL-EL15	63220	49
HDS	74502	110	HSA8CM	62506	43	HTF242-S/S	62831	15	HV-1400-SAC-CL-S/S	62645	45
HDS-S/S	75586	111	HSA8CM	62506	47	HTF248	76664	15	HV-1400-SAC-CL-S/S-EL15	63241	51
HEX NUT	G1211	55	HSA8CM	62506	48	HTF248-S/S	62832	15	HV-1400-SAC-CM	62528	43
HEX NUT	G1211	72	HSA8CM	62506	49	HTF254	76665	15	HV-1400-SAC-CM-EL15	63219	49
HEX NUT	G1211	77	HSA8CM	62506	53	HTF254-S/S	62833	15	HV-1400-SAC-CM-S/S	62644	45
HEX NUT	G1211	97	HSA8CM	62506	54	HTF260	76666	15	HV-1400-SAC-CM-S/S-EL15	63240	51
HMK	73054	42	HSA8CM-S/S	62510	45	HTF260-S/S	62834	15	HV-1400-SAC-CS	62527	43
HMK-S/S	75424	42	HSA8CM-S/S	62510	47	HTF272	76667	15	HV-1400-SAC-CS-EL15	63218	49
HP1050	73035	42	HSA8CM-S/S	62510	48	HTF272-S/S	62835	15	HV-1400-SAC-CS-S/S	62643	45
HP1050-S/S	75377	42	HSA8CM-S/S	62510	51	HTS	74141	126	HV-1400-SAC-CS-S/S-EL15	63239	51
HP1200	73037	42	HSA8CM-S/S	62510	53	HV-1000-SAC-CL	62523	43	HV-1600-2SAC-CL	62566	43
HP1200-S/S	75378	42	HSA8CM-S/S	62510	54	HV-1000-SAC-CL-EL15	63214	49	HV-1600-2SAC-CL-EL15	63430	49
HP1500	73066	42	HSA8CS	62505	43	HV-1000-SAC-CL-S/S	62639	45	HV-1600-2SAC-CL-S/S	62582	45
HP1500-S/S	75379	42	HSA8CS	62505	47	HV-1000-SAC-CL-S/S-EL15	63235	51	HV-1600-2SAC-CL-S/S-EL15	63462	51
HP1600	73739	42	HSA8CS	62505	48	HV-1000-SAC-CM	62522	43	HV-1600-2SAC-CLL	62567	43
HP1600-S/S	75380	42	HSA8CS	62505	49	HV-1000-SAC-CM-EL15	63213	49	HV-1600-2SAC-CLL-EL15	63431	49
HP450	73027	42	HSA8CS	62505	53	HV-1000-SAC-CM-S/S	62638	45	HV-1600-2SAC-CLL-S/S	62683	45
HP450-S/S	75373	42	HSA8CS	62505	54	HV-1000-SAC-CM-S/S-EL15	63234	51	HV-1600-2SAC-CLL-S/S-EL15	63463	51
HP600	73029	42	HSA8CS-S/S	62509	45	HV-1000-SAC-CS	62521	43	HV-1600-2SAC-CM	62565	43
HP600-S/S	75374	42	HSA8CS-S/S	62509	47	HV-1000-SAC-CS-EL15	63212	49	HV-1600-2SAC-CM-EL15	63429	49
HP750	73031	42	HSA8CS-S/S	62509	48	HV-1000-SAC-CS-S/S	62637	45	HV-1600-2SAC-CM-S/S	62681	45
HP750-S/S	75375	42	HSA8CS-S/S	62509	51	HV-1000-SAC-CS-S/S-EL15	63233	51	HV-1600-2SAC-CM-S/S-EL15	63461	51
HP900	73033	42	HSA8CS-S/S	62509	53	HV-1200-2SAC-CL	62559	43	HV-1600-SAC-CL	62531	43
HP900-S/S	75376	42	HSA8CS-S/S	62509	54	HV-1200-2SAC-CL-EL15	63423	49	HV-1600-SAC-CL-EL15	63222	49
HPHD1800	74601	42	HSA8L	73063	38	HV-1200-2SAC-CL-S/S	62675	45	HV-1600-SAC-CL-S/S	62647	45
HPHD1800-S/S	A2063	42	HSA8L	73063	40	HV-1200-2SAC-CL-S/S-EL15	63455	51	HV-1600-SAC-CL-S/S-EL15	63243	51
HPHD2000	74547	42	HSA8L-S/S	73774	39	HV-1200-2SAC-CLL	62560	43	HV-1600-SAC-CLL	62532	43
HPHD2000-S/S	A1783	42	HSA8L-S/S	73774	41	HV-1200-2SAC-CLL-EL15	63424	49	HV-1600-SAC-CLL-EL15	63223	49
HPHD2400	74548	42	HSA8LL	73064	38	HV-1200-2SAC-CLL-S/S	62676	45	HV-1600-SAC-CLL-S/S	62648	45
HPHD2400-S/S	A2590	42	HSA8LL	73064	40	HV-1200-2SAC-CLL-S/S-EL15	63456	51	HV-1600-SAC-CLL-S/S-EL15	63244	51
HPS8	73050	42	HSA8LL-S/S	74033	39	HV-1200-2SAC-CM	62558	43	HV-1600-SAC-CM	62530	43
HSA	73486	42	HSA8LL-S/S	74033	41	HV-1200-2SAC-CM-EL15	63422	49	HV-1600-SAC-CM-EL15	63221	49
HSA200	73489	38	HSA8M	73049	38	HV-1200-2SAC-CM-S/S	62674	45	HV-1600-SAC-CM-S/S	62646	45
HSA200	73489	40	HSA8M	73049	40	HV-1200-2SAC-CM-S/S-EL15	63454	51	HV-1600-SAC-CM-S/S-EL15	63242	51
HSA200	73489	42	HSA8M-S/S	73773	39	HV-1200-2SAC-CS	62557	43	HV-1800-2SAC-CL	62569	43
HSA200	73489	43	HSA8M-S/S	73773	41	HV-1200-2SAC-CS-EL15	63421	49	HV-1800-2SAC-CL-EL15	63433	49
HSA200	73489	47	HSA8S	73048	38	HV-1200-2SAC-CS-S/S	62673	45	HV-1800-2SAC-CL-S/S	62685	45
HSA200	73489	48	HSA8S	73048	40	HV-1200-2SAC-CS-S/S-EL15	63453	51	HV-1800-2SAC-CL-S/S-EL15	63465	51
HSA200	73489	49	HSA8S-S/S	73772	39	HV-1200-SAC-CL	62526	43	HV-1800-2SAC-CLL	62570	43
HSA200	73489	53	HSA8S-S/S	73772	41	HV-1200-SAC-CL-EL15	63217	49	HV-1800-2SAC-CLL-EL15	63434	49
HSA200	73489	54	HSA8SS	73047	38	HV-1200-SAC-CL-S/S	62642	45	HV-1800-2SAC-CLL-S/S	62686	45
HSA200-EL15	76027	49	HSA8SS	73047	40	HV-1200-SAC-CL-S/S-EL15	63238	51	HV-1800-2SAC-CLL-S/S-EL15	63466	51
HSA200-EL15	76027	53	HSA8SS-S/S	73771	39	HV-1200-SAC-CM	62525	43	HV-1800-2SAC-CM	62568	43
HSA200-EL15	76027	54	HSA8SS-S/S	73771	41	HV-1200-SAC-CM-EL15	63216	49	HV-1800-2SAC-CM-EL15	63432	49
HSA8CL	62507	43	HSA8SSS	75565	39	HV-1200-SAC-CM-S/S	62641	45	HV-1800-2SAC-CM-S/S	62684	45



INDEX By Ordering Number

Ordering Number	Item Code	Page #	Ordering Number	Item Code	Page #	Ordering Number	Item Code	Page #	Ordering Number	Item Code	Page #
HV-1800-2SAC-CM-S/S-EL15	63464	51	HV-2800-2SAC-CLL-S/S-EL15	63481	51	HV1200S-S/S	75311	39	HV750M	73174	38
HV-1800-SAC-CL	62534	43	HV-2800-2SAC-CM	62583	43	HV1200SS	73059	38	HV750M-PCST	63944	40
HV-1800-SAC-CL-EL15	63225	49	HV-2800-2SAC-CM-EL15	63447	49	HV1200SS-PCST	63953	40	HV750M-PCST-S/S	63986	41
HV-1800-SAC-CL-S/S	62650	45	HV-2800-2SAC-CM-S/S	62699	45	HV1200SS-PCST-S/S	63995	41	HV750M-S/S	75301	39
HV-1800-SAC-CL-S/S-EL15	63246	51	HV-2800-2SAC-CM-S/S-EL15	63479	51	HV1200SS-S/S	75310	39	HV750S	73032	38
HV-1800-SAC-CLL	62535	43	HV-3000-2SAC-CL	62587	43	HV1500L	73158	38	HV750S-PCST	63943	40
HV-1800-SAC-CLL-EL15	63226	49	HV-3000-2SAC-CL-EL15	63451	49	HV1500L-PCST	63958	40	HV750S-PCST-S/S	63985	41
HV-1800-SAC-CLL-S/S	62651	45	HV-3000-2SAC-CL-S/S	62703	45	HV1500L-PCST-S/S	64000	41	HV750S-S/S	75300	39
HV-1800-SAC-CLL-S/S-EL15	63247	51	HV-3000-2SAC-CL-S/S-EL15	63483	51	HV1500L-S/S	75315	39	HV750SS	73053	38
HV-1800-SAC-CM	62533	43	HV-3000-2SAC-CLL	62588	43	HV1500LL	73215	38	HV750SS-PCST	63942	40
HV-1800-SAC-CM-EL15	63224	49	HV-3000-2SAC-CLL-EL15	63452	49	HV1500LL-PCST	63959	40	HV750SS-PCST-S/S	63984	41
HV-1800-SAC-CM-S/S	62649	45	HV-3000-2SAC-CLL-S/S	62704	45	HV1500LL-PCST-S/S	64001	41	HV750SS-S/S	75299	39
HV-1800-SAC-CM-S/S-EL15	63245	51	HV-3000-2SAC-CLL-S/S-EL15	63484	51	HV1500LL-S/S	75316	39	HV900L	73178	38
HV-2000-2SAC-CL	62572	43	HV-3000-2SAC-CM	62586	43	HV1500M	73177	38	HV900L-PCST	63948	40
HV-2000-2SAC-CL-EL15	63436	49	HV-3000-2SAC-CM-EL15	63450	49	HV1500M-PCST	63957	40	HV900L-PCST-S/S	63990	41
HV-2000-2SAC-CL-S/S	62688	45	HV-3000-2SAC-CM-S/S	62702	45	HV1500M-PCST-S/S	63999	41	HV900L-S/S	75305	39
HV-2000-2SAC-CL-S/S-EL15	63468	51	HV-3000-2SAC-CM-S/S-EL15	63482	51	HV1500M-S/S	75314	39	HV900M	73175	38
HV-2000-2SAC-CLL	62573	43	HV-600-SAC-CL	62517	43	HV1600L	73638	38	HV900M-PCST	63947	40
HV-2000-2SAC-CLL-EL15	63437	49	HV-600-SAC-CL-EL15	63208	49	HV1600L-PCST	63961	40	HV900M-PCST-S/S	63989	41
HV-2000-2SAC-CLL-S/S	62689	45	HV-600-SAC-CL-S/S	62633	45	HV1600L-PCST-S/S	64003	41	HV900M-S/S	75304	39
HV-2000-2SAC-CLL-S/S-EL15	63469	51	HV-600-SAC-CL-S/S-EL15	63229	51	HV1600L-S/S	75318	39	HV900S	73034	38
HV-2000-2SAC-CM	62571	43	HV-600-SAC-CM	62516	43	HV1600LL	73639	38	HV900S-PCST	63946	40
HV-2000-2SAC-CM-EL15	63435	49	HV-600-SAC-CM-EL15	63207	49	HV1600LL-PCST	63962	40	HV900S-PCST-S/S	63988	41
HV-2000-2SAC-CM-S/S	62687	45	HV-600-SAC-CM-S/S	62632	45	HV1600LL-PCST-S/S	64004	41	HV900S-S/S	75303	39
HV-2000-2SAC-CM-S/S-EL15	63467	51	HV-600-SAC-CM-S/S-EL15	63228	51	HV1600LL-S/S	75319	39	HV900SS	73055	38
HV-2200-2SAC-CL	62575	43	HV-600-SAC-CS	62515	43	HV1600M	73637	38	HV900SS-PCST	63945	40
HV-2200-2SAC-CL-EL15	63439	49	HV-600-SAC-CS-EL15	63206	49	HV1600M-PCST	63960	40	HV900SS-PCST-S/S	63987	41
HV-2200-2SAC-CL-S/S	62691	45	HV-600-SAC-CS-S/S	62631	45	HV1600M-PCST-S/S	64002	41	HV900SS-S/S	75302	39
HV-2200-2SAC-CL-S/S-EL15	63471	51	HV-600-SAC-CS-S/S-EL15	63227	51	HV1600M-S/S	75317	39	HVC-S/S	73494	42
HV-2200-2SAC-CLL	62576	43	HV-800-SAC-CL	62520	43	HV1800L-PCST	63964	40	HVHD1800L	74477	38
HV-2200-2SAC-CLL-EL15	63440	49	HV-800-SAC-CL-EL15	63211	49	HV1800LL-PCST	63965	40	HVHD1800L-PCST-S/S	64006	41
HV-2200-2SAC-CLL-S/S	62692	45	HV-800-SAC-CL-S/S	62636	45	HV1800M-PCST	63963	40	HVHD1800L-S/S	A1595	39
HV-2200-2SAC-CLL-S/S-EL15	63472	51	HV-800-SAC-CL-S/S-EL15	63232	51	HV2100L-PCST	63967	40	HVHD1800LL	74478	38
HV-2200-2SAC-CM	62574	43	HV-800-SAC-CM	62519	43	HV2100LL-PCST	63968	40	HVHD1800LL-PCST-S/S	64007	41
HV-2200-2SAC-CM-EL15	63438	49	HV-800-SAC-CM-EL15	63210	49	HV2100M-PCST	63966	40	HVHD1800LL-S/S	A1596	39
HV-2200-2SAC-CM-S/S	62690	45	HV-800-SAC-CM-S/S	62635	45	HV2400L-PCST	63970	40	HVHD1800M	74602	38
HV-2200-2SAC-CM-S/S-EL15	63470	51	HV-800-SAC-CM-S/S-EL15	63231	51	HV2400LL-PCST	63971	40	HVHD1800M-PCST-S/S	64005	41
HV-2400-2SAC-CL	62578	43	HV-800-SAC-CS	62518	43	HV2400M-PCST	63969	40	HVHD1800M-S/S	A1594	39
HV-2400-2SAC-CL-EL15	63442	49	HV-800-SAC-CS-EL15	63209	49	HV2600L-PCST	63973	40	HVHD2100L	74540	38
HV-2400-2SAC-CL-S/S	62694	45	HV-800-SAC-CS-S/S	62634	45	HV2600LL-PCST	63974	40	HVHD2100L-PCST-S/S	64009	41
HV-2400-2SAC-CL-S/S-EL15	63474	51	HV-800-SAC-CS-S/S-EL15	63230	51	HV2600M-PCST	63972	40	HVHD2100L-S/S	A1598	39
HV-2400-2SAC-CLL	62579	43	HV1050L	73179	38	HV3000L-PCST	63976	40	HVHD2100LL	74541	38
HV-2400-2SAC-CLL-EL15	63443	49	HV1050L-PCST	63952	40	HV3000LL-PCST	63977	40	HVHD2100LL-PCST-S/S	64010	41
HV-2400-2SAC-CLL-S/S	62695	45	HV1050L-PCST-S/S	63994	41	HV3000M-PCST	63975	40	HVHD2100LL-S/S	A1599	39
HV-2400-2SAC-CLL-S/S-EL15	63475	51	HV1050L-S/S	75309	39	HV450M	73019	38	HVHD2100M	74539	38
HV-2400-2SAC-CM	62577	43	HV1050M	73036	38	HV450M-PCST	63938	40	HVHD2100M-PCST-S/S	64008	41
HV-2400-2SAC-CM-EL15	63441	49	HV1050M-PCST	63951	40	HV450M-PCST-S/S	63980	41	HVHD2100M-S/S	A1597	39
HV-2400-2SAC-CM-S/S	62693	45	HV1050M-PCST-S/S	63993	41	HV450M-S/S	75295	39	HVHD2400L	74545	38
HV-2400-2SAC-CM-S/S-EL15	63473	51	HV1050M-S/S	75308	39	HV450S	73028	38	HVHD2400L-PCST-S/S	64012	41
HV-2600-2SAC-CL	62581	43	HV1050S	73056	38	HV450S-PCST	63937	40	HVHD2400L-S/S	A1601	39
HV-2600-2SAC-CL-EL15	63445	49	HV1050S-PCST	63950	40	HV450S-PCST-S/S	63979	41	HVHD2400LL	74546	38
HV-2600-2SAC-CL-S/S	62697	45	HV1050S-PCST-S/S	63992	41	HV450S-S/S	75294	39	HVHD2400LL-PCST-S/S	64013	41
HV-2600-2SAC-CL-S/S-EL15	63477	51	HV1050S-S/S	75307	39	HV450SS	73026	38	HVHD2400LL-S/S	A1602	39
HV-2600-2SAC-CLL	62582	43	HV1050SS	73057	38	HV450SS-PCST	63936	40	HVHD2400M	74544	38
HV-2600-2SAC-CLL-EL15	63446	49	HV1050SS-PCST	64045	40	HV450SS-PCST-S/S	63978	41	HVHD2400M-PCST-S/S	64011	41
HV-2600-2SAC-CLL-S/S	62698	45	HV1050SS-PCST-S/S	63991	41	HV450SS-S/S	75293	39	HVHD2400M-S/S	A1600	39
HV-2600-2SAC-CLL-S/S-EL15	63478	51	HV1050SS-S/S	75306	39	HV600M	73173	38	HVHD2600L	A2461	38
HV-2600-2SAC-CM	62580	43	HV1200L	73180	38	HV600M-PCST	63941	40	HVHD2600L-PCST-S/S	64015	41
HV-2600-2SAC-CM-EL15	63444	49	HV1200L-PCST	63956	40	HV600M-PCST-S/S	63983	41	HVHD2600L-S/S	A2463	39
HV-2600-2SAC-CM-S/S	62696	45	HV1200L-PCST-S/S	63998	41	HV600M-S/S	75298	39	HVHD2600LL	A2397	38
HV-2600-2SAC-CM-S/S-EL15	63476	51	HV1200L-S/S	75313	39	HV600S	73030	38	HVHD2600LL-PCST-S/S	64016	41
HV-2800-2SAC-CL	62584	43	HV1200M	73038	38	HV600S-PCST	63940	40	HVHD2600LL-S/S	A2464	39
HV-2800-2SAC-CL-EL15	63448	49	HV1200M-PCST	63955	40	HV600S-PCST-S/S	63982	41	HVHD2600M	A2396	38
HV-2800-2SAC-CL-S/S	62700	45	HV1200M-PCST-S/S	63997	41	HV600S-S/S	75297	39	HVHD2600M-PCST-S/S	64014	41
HV-2800-2SAC-CL-S/S-EL15	63480	51	HV1200M-S/S	75312	39	HV600SS	73045	38	HVHD2600M-S/S	A2462	39
HV-2800-2SAC-CLL	62585	43	HV1200S	73058	38	HV600SS-PCST	63939	40	HVHD3000L	74592	38
HV-2800-2SAC-CLL-EL15	63449	49	HV1200S-PCST	63954	40	HV600SS-PCST-S/S	63981	41	HVHD3000L-PCST-S/S	64018	41
HV-2800-2SAC-CLL-S/S	62701	45	HV1200S-PCST-S/S	63996	41	HV600SS-S/S	75296	39	HVHD3000L-S/S	A2466	39

INDEX By Ordering Number

Ordering Number	Item Code	Page #	Ordering Number	Item Code	Page #	Ordering Number	Item Code	Page #	Ordering Number	Item Code	Page #
HVHD3000LL	74593	38	HXF750S	74663	36	IMK	76936	140	MBCMK	79524	116
HVHD3000LL-PCST-S/S	64019	41	HXF750S-S/S	75270	37	ISABK	76935	141	MBCMCK	79533	116
HVHD3000LL-S/S	A2467	39	HXF8L	74691	36	ISABK-LMH	77529	138	MBCTA	79531	116
HVHD3000M	74591	38	HXF8L	74691	37	ISABK-LMH	77529	139	MBDS-18	79504	116
HVHD3000M-PCST-S/S	64017	41	HXF8L-Blue	77521	36	ISABK-LMH	77529	140	MBDS-24	79505	116
HVHD3000M-S/S	A2465	39	HXF8L-Blue	77521	37	LS-BP	77114	12	MBDS-30	79506	116
HVPT-S/S	73631	38	HXF8M	74690	36	LS-BP-S/S	77115	13	MBDS-36	79507	116
HVPT-S/S	73631	39	HXF8M	74690	37	LS-SP	77365	12	MBDS-42	79508	116
HVPT-S/S	73631	40	HXF8M-Blue	77520	36	LS-SS	77118	12	MBDS-48	79509	116
HVPT-S/S	73631	41	HXF8M-Blue	77520	37	LS-SS	77118	13	MBDS-54	79510	116
HVPT-S/S	73631	42	HXF8S	74689	36	LS-SW	77117	12	MBDS-60	79511	116
HVPT-S/S	73631	45	HXF8S	74689	37	LS-SW-S/S	78850	13	MBDS-72	79512	116
HVPT-S/S	73631	47	HXF8S-Blue	77519	36	LSP12	77070	12	MBDS-84	79513	116
HVPT-S/S	73631	48	HXF8S-Blue	77519	37	LSP12-S/S	77079	13	MBRD-18	79514	114
HVPT-S/S	73631	51	HXF8SS	74307	36	LSP18	77071	12	MBRD-18	79514	116
HVPT-S/S	73631	53	HXF8SS	74307	37	LSP18-S/S	77080	13	MBRD-24	79515	114
HVPT-S/S	73631	54	HXF8SS-Blue	77518	36	LSP24	77072	12	MBRD-24	79515	116
HVT8-EL15-S/S	62254	53	HXF8SS-Blue	77518	37	LSP24-S/S	77081	13	MBRD-30	79516	114
HVT8-EL15-S/S	63566	54	HXF900L	74667	36	LSP30	77073	12	MBRD-30	79516	116
HVT8-S/S	75419	39	HXF900L-S/S	75274	37	LSP30-S/S	77082	13	MBRD-36	79517	114
HVT8-S/S	75419	41	HXF900M	74666	36	LSP36	77074	12	MBRD-36	79517	116
HVT8-S/S	75419	42	HXF900M-S/S	75273	37	LSP36-S/S	77083	13	MBRD-42	79518	114
HVT8-S/S	75419	45	HXF900S	74665	36	LSP42	77075	12	MBRD-42	79518	116
HVT8-S/S	75419	47	HXF900S-S/S	75272	37	LSP42-S/S	77084	13	MBRD-48	79519	114
HVT8-S/S	75419	48	HXFHD1800L	74682	36	LSP48	77076	12	MBRD-48	79519	116
HVT8-S/S	75419	51	HXFHD1800L-S/S	A1589	37	LSP48-S/S	77085	13	MBRD-54	79520	114
HVT8-S/S	75419	53	HXFHD1800M	74681	36	LSP54	77077	12	MBRD-54	79520	116
HVT8-S/S	75419	54	HXFHD1800M-S/S	A1588	37	LSP54-S/S	77086	13	MBRD-60	79521	114
HW-BC	74100	126	HXFHD2100L	74684	36	LSP60	77078	12	MBRD-60	79521	116
HW-IMPB	76939	142	HXFHD2100L-S/S	A1591	37	LSP60-S/S	77087	13	MBRD-72	79522	114
HXF1050L	74670	36	HXFHD2100M	74683	36	LST-B-S/S	77124	13	MBRD-72	79522	116
HXF1050L-S/S	75277	37	HXFHD2100M-S/S	A1590	37	LST-P	77121	12	MBRD-84	79523	114
HXF1050M	74669	36	HXFHD2400L	74686	36	LST-S	77123	12	MBRD-84	79523	116
HXF1050M-S/S	75276	37	HXFHD2400L-S/S	A1593	37	LST-TAK	77120	12	MCB	74925	165
HXF1050S	74668	36	HXFHD2400M	74685	36	LST-TAK	77120	13	MCB	74925	165
HXF1050S-S/S	75275	37	HXFHD2400M-S/S	A1592	37	LST-W	77122	12	MCBK	76025	165
HXF1200L	74673	36	IB4	76926	132	LST-W-S/S	77125	13	MCBK	76025	165
HXF1200L-S/S	75280	37	IB4	76926	134	LST-W-S/S-2	77126	13	MCBKHD	76026	165
HXF1200M	74672	36	IB4	76926	136	LSTMPK	77366	12	MCBKHD	76026	165
HXF1200M-S/S	75279	37	IB4	76926	138	LSTMPK-S/S	78933	13	MCRK	74923	165
HXF1200S	74671	36	IB4	76926	139	LSTMPK2-S/S	78462	13	MCRK	74923	165
HXF1200S-S/S	75278	37	IB4	76926	140	LSTPB-RK	77367	12	MCS	74930	165
HXF1500L	74678	36	IB4-1U	76965	142	LSTPB-RK	77367	13	MCS	74930	165
HXF1500L-S/S	75282	37	IB5	76927	132	MAK	74918	165	MCSHD	74931	165
HXF1500M	74677	36	IB5	76927	134	MAK-S/S	64926	165	MCSHD	74931	165
HXF1500M-S/S	75281	37	IB5	76927	136	MAKHD	74919	165	MCSK	74927	165
HXF1600L	73444	36	IB5	76927	138	MAKHD	74919	165	MCSK	74927	165
HXF1600L-S/S	75284	37	IB5	76927	139	MAPEK	76024	127	MCSKHD	74928	165
HXF1600M	73443	36	IB5	76927	140	MBADB	79527	116	MCSKHD	74928	165
HXF1600M-S/S	75283	37	IB5	76927	141	MBC-18	79494	114	MESBK-PS	82364	110
HXF2-L	75982	36	IB5-1U	76966	142	MBC-24	79495	114	MESBK-PS	82364	111
HXF2-L	75982	37	IBBK	76928	138	MBC-30	79496	114	MESPBL	87895	110
HXF2-M	75981	36	IBBK	76928	139	MBC-36	79497	114	MESPBL-SS	82892	111
HXF2-M	75981	37	IBBK	76928	140	MBC-42	79498	114	MESPKR	81896	110
HXF2-S	75980	36	IBBK	76928	141	MBC-48	79499	114	MESPKR-SS	82894	111
HXF2-S	75980	37	IBS-DH5	76934	140	MBC-54	79500	114	MFASK	75531	165
HXF2-SS	75979	36	IBS-DH5	76934	141	MBC-60	79501	114	MFASK	75531	165
HXF2-SS	75979	37	IBS-H4	76933	140	MBC-72	79502	114	MHCP-1050S-S/S	61507	33
HXF450M	74660	36	IBS-L4	76929	138	MBC-84	79503	114	MHCP-1050S-S/S-FR	61627	33
HXF450M-S/S	75267	37	IBS-L5	76930	138	MBCB	79526	116	MHCP-1200S-S/S	61508	33
HXF450S	74659	36	IBS-M1200	82397	136	MBCBC	79525	116	MHCP-1200S-S/S-FR	61628	33
HXF450S-S/S	75266	37	IBS-M1500	82398	136	MBCBL	79532	116	MHCP-1350S-S/S	61509	33
HXF600M	74662	36	IBS-M4	76931	139	MBCBM	79528	116	MHCP-1350S-S/S-FR	61629	33
HXF600M-S/S	75269	37	IBS-M5	76932	139	MBCDBK	79536	114	MHCP-1500S-S/S	61510	33
HXF600S	74661	36	IEA42-60D	76937	141	MBCDBK	79536	116	MHCP-1500S-S/S-FR	61630	33
HXF600S-S/S	75268	37	IEA72-96D	76938	141	MBCCEC	79534	116	MHCP-1650S-S/S	61511	33
HXF750M	74664	36	IMK	76936	138	MBCM-1	79529	116	MHCP-1650S-S/S-FR	61631	33
HXF750M-S/S	75271	37	IMK	76936	139	MBCM-2	79530	116	MHCP-1800S-S/S	61512	33

INDEX By Ordering Number

Ordering Number	Item Code	Page #	Ordering Number	Item Code	Page #	Ordering Number	Item Code	Page #	Ordering Number	Item Code	Page #
MHCP-1800S-S/S-FR	61632	33	MHP-CP1500	75967	32	MHS-1800BTV-2SAC	78016	101	MHS-CARK-V24/600	77937	102
MHCP-2100S-S/S	61513	33	MHP-CP1800	75968	32	MHS-1800BTV-2SAC-S/S	78325	101	MHS-CARK-V24/600-S/S		
MHCP-2100S-S/S-FR	61633	33	MHP-CP2100	76811	32	MHS-1800BTV-S/S	77496	73	MVECKS/S	82841	95
MHCP-24A	75937	30	MHP-CP600	75961	32	MHS-1800BTV-SAC	78014	101	MHS-CARK-V24/600-S/S		
MHCP-24S	75929	30	MHP-CP750	75962	32	MHS-1800BTV-SAC-S/S	78323	101	MVECKS/S	82841	102
MHCP-2BC24	76638	32	MHP-CP900	75963	32	MHS-1800FPV	77796	75	MHS-CARK-V30/750	77938	95
MHCP-2BC30	76639	32	MHP-EP	76392	25	MHS-1800FPV-S/S	77806	75	MHS-CARK-V30/750	77938	102
MHCP-2BC36	76640	32	MHP-EP	76392	32	MHS-1800V-2SAC	78171	94	MHS-CARK-V30/750-S/S		
MHCP-2BC42	76641	32	MHP-EP	76392	48	MHS-1800V-2SAC-S/S	78546	94	MVECKS/S	82842	95
MHCP-2BC48	76642	32	MHP-EP	76392	54	MHS-1800V-SAC	78169	94	MHS-CARK-V30/750-S/S		
MHCP-2BC54	76643	32	MHP-EP	76392	82	MHS-1800V-SAC-S/S	78544	94	MVECKS/S	82842	102
MHCP-2BC60	76644	32	MHP-EP	76392	89	MHS-1950BTV-2SAC-S/S	78649	101	MHS-CARK-V36/900	77939	95
MHCP-2BC72	76645	32	MHP-EP	76392	96	MHS-1950V-2SAC-S/S	78649	94	MHS-CARK-V36/900	77939	102
MHCP-2BC84	76812	32	MHP-EP	76392	103	MHS-2100-MST	64028	70	MHS-CARK-V36/900-S/S		
MHCP-30A	75938	30	MHP-EP-S/S	77599	27	MHS-2100-MST-S/S	64038	70	MVECKS/S	82843	95
MHCP-30S	75930	30	MHP-EP-S/S	77599	48	MHS-2100BTV	77488	73	MHS-CARK-V36/900-S/S		
MHCP-36A	75939	30	MHP-EP-S/S	77599	54	MHS-2100BTV-2SAC	78017	101	MVECKS/S	82843	102
MHCP-36S	75931	30	MHP-EP-S/S	77599	84	MHS-2100BTV-2SAC-S/S	78326	101	MHS-CARK-V42/1050	77940	95
MHCP-42A	75940	30	MHP-EP-S/S	77599	91	MHS-2100BTV-S/S	77497	73	MHS-CARK-V42/1050	77940	102
MHCP-42S	75932	30	MHP-EP-S/S	77599	98	MHS-2100FPV	77797	75	MHS-CARK-V42/1050-S/S		
MHCP-48A	75941	30	MHP-EP-S/S	77599	104	MHS-2100FPV-S/S	77807	75	MVECKS/S	82844	95
MHCP-48S	75933	30	MHS-1050-MST	64023	70	MHS-2100V-2SAC	78172	94	MHS-CARK-V42/1050-S/S		
MHCP-54A	75942	30	MHS-1050-MST-S/S	64033	70	MHS-2100V-2SAC-S/S	78547	94	MVECKS/S	82844	102
MHCP-54S	75934	30	MHS-1050BTV	77484	73	MHS-2400-MST	64029	70	MHS-CARK-V48/1200	77941	95
MHCP-600S-S/S	61504	33	MHS-1050BTV-S/S	77493	73	MHS-2400-MST-S/S	64039	70	MHS-CARK-V48/1200	77941	102
MHCP-600S-S/S-FR	61624	33	MHS-1050BTV-SAC	78010	101	MHS-2400BTV	77489	73	MHS-CARK-V48/1200-S/S		
MHCP-60A	75943	30	MHS-1050BTV-SAC-S/S	78319	101	MHS-2400BTV-2SAC	78018	101	MVECKS/S	82845	95
MHCP-60S	75935	30	MHS-1050FPV	77792	75	MHS-2400BTV-2SAC-S/S	78327	101	MHS-CARK-V48/1200-S/S		
MHCP-72A	75944	30	MHS-1050FPV-S/S	77802	75	MHS-2400BTV-S/S	77498	73	MVECKS/S	82845	102
MHCP-72S	75936	30	MHS-1050V-SAC	78165	94	MHS-2400FPV	77798	75	MHS-CARK-V54/1350	77942	95
MHCP-750S-S/S	61505	33	MHS-1050V-SAC-S/S	78540	94	MHS-2400FPV-S/S	77808	75	MHS-CARK-V54/1350-S/S		
MHCP-750S-S/S-FR	61625	33	MHS-1200-MST	64024	70	MHS-2400V-2SAC	78173	94	MVECKS/S	82846	95
MHCP-84A	76801	30	MHS-1200-MST-S/S	64034	70	MHS-2400V-2SAC-S/S	78548	94	MHS-CARK-V54/1350-S/S		
MHCP-84S	76800	30	MHS-1200BTV	77525	73	MHS-3000BTV-2SAC	78019	101	MVECKS/S	82846	102
MHCP-900S-S/S	61506	33	MHS-1200BTV-S/S	77526	73	MHS-3000BTV-2SAC-S/S	78328	101	MHS-CARK-V60/1500	77943	95
MHCP-900S-S/S-FR	61626	33	MHS-1200BTV-SAC	78011	101	MHS-3000V-2SAC	78174	94	MHS-CARK-V60/1500	77943	102
MHCP-BS	76394	32	MHS-1200BTV-SAC-S/S	78320	101	MHS-3000V-2SAC-S/S	78549	94	MHS-CARK-V60/1500-S/S		
MHCP-CH	76393	32	MHS-1200FPV	77793	75	MHS-600-MST	64020	70	MVECKS/S	82847	95
MHCP-S/S-CBK	61550	35	MHS-1200FPV-S/S	77803	75	MHS-600-MST-S/S	64030	70	MHS-CARK-V60/1500-S/S		
MHCP-S/S-CEB	61549	35	MHS-1200V-SAC	78166	94	MHS-600BTV	77481	73	MVECKS/S	82847	102
MHCP-S/S-CH	61548	35	MHS-1200V-SAC-S/S	78541	94	MHS-600BTV-S/S	77490	73	MHS-CARK-V72/1800	77944	95
MHCP-S/S-CK1050	61538	35	MHS-1350-MST	64025	70	MHS-600BTV-SAC	78007	101	MHS-CARK-V72/1800	77944	102
MHCP-S/S-CK1200	61539	35	MHS-1350-MST-S/S	64035	70	MHS-600BTV-SAC-S/S	78316	101	MVECKS/S	82848	95
MHCP-S/S-CK1350	61540	35	MHS-1350BTV	77485	73	MHS-600FPV	77789	75	MHS-CARK-V72/1800-S/S		
MHCP-S/S-CK1500	61541	35	MHS-1350BTV-S/S	77494	73	MHS-600FPV-S/S	77799	75	MVECKS/S	82848	102
MHCP-S/S-CK1650	61542	35	MHS-1350BTV-SAC	78012	101	MHS-600V-SAC	78162	94	MHS-CARK2-V120/3000	77954	95
MHCP-S/S-CK1800	61543	35	MHS-1350BTV-SAC-S/S	78321	101	MHS-600V-SAC-S/S	78537	94	MHS-CARK2-V120/3000	77954	102
MHCP-S/S-CK2100	61544	35	MHS-1350FPV	77794	75	MHS-750-MST	64021	70	MHS-CARK2-V120/3000-S/S		
MHCP-S/S-CK600	61535	35	MHS-1350FPV-S/S	77804	75	MHS-750-MST-S/S	64031	70	MV2CKS	82853	95
MHCP-S/S-CK750	61536	35	MHS-1350V-SAC	78167	94	MHS-750BTV	77482	73	MHS-CARK2-V120/3000-S/S		
MHCP-S/S-CK900	61537	35	MHS-1350V-SAC-S/S	78542	94	MHS-750BTV-S/S	77491	73	MV2CKS	82853	102
MHCP-S/S-CLP	61545	35	MHS-1500-MST	64026	70	MHS-750BTV-SAC	78008	101	MHS-CARK2-V60/1500	77950	95
MHCP-S/S-CP 1050	61527	35	MHS-1500-MST-S/S	64036	70	MHS-750BTV-SAC-S/S	78317	101	MHS-CARK2-V60/1500	77950	102
MHCP-S/S-CP 1200	61528	35	MHS-1500BTV	77486	73	MHS-750FPV	77790	75	MHS-CARK2-V60/1500-S/S		
MHCP-S/S-CP 1350	61529	35	MHS-1500BTV-2SAC	78015	101	MHS-750FPV-S/S	77800	75	MV2CKSS	82849	95
MHCP-S/S-CP 1500	61530	35	MHS-1500BTV-2SAC-S/S	78324	101	MHS-750V-SAC	78163	94	MHS-CARK2-V60/1500-S/S		
MHCP-S/S-CP 1650	61531	35	MHS-1500BTV-S/S	77495	73	MHS-750V-SAC-S/S	78538	94	MV2CKSS	82849	102
MHCP-S/S-CP 1800	61532	35	MHS-1500BTV-SAC	78013	101	MHS-900-MST	64022	70	MHS-CARK2-V72/1800	77951	95
MHCP-S/S-CP 2100	61533	35	MHS-1500BTV-SAC-S/S	78322	101	MHS-900-MST-S/S	64032	70	MHS-CARK2-V72/1800-S/S		
MHCP-S/S-CP 600	61634	35	MHS-1500FPV	77795	75	MHS-900BTV	77483	73	MV2CKSS	82850	95
MHCP-S/S-CP 750	61525	35	MHS-1500FPV-S/S	77805	75	MHS-900BTV-S/S	77492	73	MHS-CARK2-V72/1800-S/S		
MHCP-S/S-CP 900	61526	35	MHS-1500V-2SAC	78170	94	MHS-900BTV-SAC	78009	101	MV2CKSS	82850	102
MHCP-S/S-PSTS	61547	35	MHS-1500V-2SAC-S/S	78545	94	MHS-900BTV-SAC-S/S	78318	101	MHS-CARK2-V84/2100	77952	95
MHCP-S/S-PSTW	61546	35	MHS-1500V-SAC	78168	94	MHS-900FPV	77791	75	MHS-CARK2-V84/2100	77952	102
MHCP-SS/EP	61534	35	MHS-1500V-SAC-S/S	78543	94	MHS-900FPV-S/S	77801	75	MHS-CARK2-V84/2100-S/S		
MHP-CP1050	75964	32	MHS-1800-MST	64027	70	MHS-900V-SAC	78164	94	MV2CKSS	82851	95
MHP-CP1200	75965	32	MHS-1800-MST-S/S	64037	70	MHS-900V-SAC-S/S	78539	94	MHS-CARK2-V84/2100-S/S		
MHP-CP1400	75966	32	MHS-1800BTV	77487	73	MHS-CARK-V24/600	77937	95	MV2CKSS	82851	102

INDEX By Ordering Number

Ordering Number	Item Code	Page #	Ordering Number	Item Code	Page #	Ordering Number	Item Code	Page #	Ordering Number	Item Code	Page #
MHS-CARK2-V96/2400	77953	102	MMKUHD	77327	110	MSTAM	79435	69	P-CARK-V30/750-S/S		
MHS-CARK2-V96/2400-S/S			MMKUHD-SS	77358	111	MSTAM-S/S	64931	69	PVECKS/S	82816	81
MV2CKSS	82852	95	MMP-624	76450	23	MSTBK	79440	69	P-CARK-V36/900	78082	81
MHS-CARK2-V96/2400-S/S			MMP-624-S/S	77424	24	MSTBK	79440	69	P-CARK-V36/900-S/S		
MV2CKSS	82852	102	MMP-630	76451	23	MSTDB	79434	72	PVECKS/S	82817	81
MHS-P1050*	77502	69	MMP-630-S/S	77425	24	MSTHD-B	79433	69	P-CARK-V42/1050	78083	81
MHS-P1050*	77502	74	MMP-636	76452	23	MSTHD-B-S/S	90183	69	P-CARK-V42/1050-S/S		
MHS-P1050*	77502	76	MMP-636-S/S	77426	24	MSTHD-G	63020	69	PVECKS/S	82818	81
MHS-P1050S/S*	77511	69	MMP-642	76453	23	MSTHD-G-S/S	90184	69	P-CARK-V48/1200	78084	81
MHS-P1050S/S*	77511	74	MMP-642-S/S	77427	24	MSTHD-S	79432	69	P-CARK-V48/1200-S/S		
MHS-P1050S/S*	77511	76	MMP-648	76454	23	MSTHD-S-S/S	90182	69	PVECKS/S	82819	81
MHS-P1200*	77527	69	MMP-648-S/S	77428	24	MSTHD-W	79431	69	P-CARK-V54/1350	78085	81
MHS-P1200*	77527	74	MMP-654	76455	23	MSTHD-W-S/S	90181	69	P-CARK-V54/1350-S/S		
MHS-P1200*	77527	76	MMP-654-S/S	77429	24	MSTLP	64930	69	PVECKS/S	82820	81
MHS-P1200S/S*	77528	69	MMP-660	76456	23	MSTLP	64930	69	P-CARK-V60/1500	78086	81
MHS-P1200S/S*	77528	74	MMP-660-S/S	77430	24	MUPSBK	82896	110	P-CARK-V60/1500-S/S P		
MHS-P1200S/S*	77528	76	MMP-672	76457	23	MUPSBK-SS	82893	111	VECKS/S	82821	81
MHS-P1350*	77503	69	MMP-672-S/S	77431	24	N6D3T-24-9-A45	26107	130	P-CARK-V72/1800	78087	81
MHS-P1350*	77503	74	MMP-684	76798	23	N6D3T-30-11-A45	26108	130	PVECKS/S	82822	81
MHS-P1350*	77503	76	MMP-684-S/S	77432	24	N6D3T-36-13-A45	26109	130	P-CARK2-V120/3000	78097	81
MHS-P1350S/S*	77512	69	MMPBPK	76466	25	N6D3T-42-15-A45	26110	130	P-CARK2-V120/3000-S/S		
MHS-P1350S/S*	77512	74	MMPBPK-S/S	77600	27	N6D3T-48-17-A45	26111	130	PV2ECKSS	82827	81
MHS-P1350S/S*	77512	76	MMPCP24	76458	25	N6D3T-54-19-A45	26112	130	P-CARK2-V60/1500	78093	81
MHS-P1500*	77504	69	MMPCP24-S/S	77590	27	N6D3T-60-21-A45	26113	130	P-CARK2-V60/1500-S/S		
MHS-P1500*	77504	74	MMPCP30	76459	25	N6D3T-72-25-A45	26114	130	PV2ECKSS	82823	81
MHS-P1500*	77504	76	MMPCP30-S/S	77591	27	NI6D3T-24-9-A45	26184	132	P-CARK2-V72/1800	78094	81
MHS-P1500S/S*	77513	69	MMPCP36	76460	25	NI6D3T-30-11-A45	26185	132	P-CARK2-V72/1800-S/S		
MHS-P1500S/S*	77513	74	MMPCP36-S/S	77592	27	NI6D3T-36-13-A45	26186	132	PV2ECKSS	82824	81
MHS-P1500S/S*	77513	76	MMPCP42	76461	25	NI6D3T-42-15-A45	26187	132	P-CARK2-V78/1950-S/S		
MHS-P1800*	77505	69	MMPCP42-S/S	77593	27	NI6D3T-48-17-A45	26188	132	PV2ECKSS	82876	81
MHS-P1800*	77505	74	MMPCP48	76462	25	NI6D3T-54-19-A45	26189	132	P-CARK2-V84/2100	78095	81
MHS-P1800*	77505	76	MMPCP48-S/S	77594	27	NI6D3T-60-21-A45	26190	132	P-CARK2-V84/2100-S/S		
MHS-P1800S/S*	77514	69	MMPCP54	76463	25	NI6D3T-72-25-A45	26191	132	V2ECKSS	82825	81
MHS-P1800S/S*	77514	74	MMPCP54-S/S	77595	27	NS6DV-18-9.625-A45	26714	160	P-CARK2-V96/2400	78096	81
MHS-P1800S/S*	77514	76	MMPCP60	76464	25	NS6DV-18-9.625-A45	26714	162	P-CARK2-V96/2400-S/S		
MHS-P2100*	77506	69	MMPCP60-S/S	77596	27	NS6DV-24-12.625-A45	26715	160	PV2ECKSS	82826	81
MHS-P2100*	77506	74	MMPCP72	76465	25	NS6DV-24-12.625-A45	26715	162	P/RMK	73025	61
MHS-P2100*	77506	76	MMPCP72-S/S	77597	27	NS6DV-30-15.625-A45	26716	162	PAB	75513	61
MHS-P2100S/S*	77515	69	MMPCP84	76808	25	NS6DV-30-15.625-A45	26716	162	PAB	75513	62
MHS-P2100S/S*	77515	74	MMPCP84-S/S	77598	27	NS6DV-36-18.625-A45	26717	162	PAB	75513	64
MHS-P2100S/S*	77515	76	MMPK	76537	127	NS6DV-36-18.625-A45	26717	162	PAB	75513	66
MHS-P2400*	77507	69	MORK	74921	165	NS6DV-42-21.625-A45	26717	162	PAB	75513	74
MHS-P2400*	77507	74	MORK	74921	165	NS6DV-42-21.625-A45	26718	160	PAB	75513	83
MHS-P2400*	77507	76	MPSTA-S/S	82289	111	NS6DV-42-21.625-A45	26718	162	PAB	75513	90
MHS-P2400S/S*	77516	69	MQMTSBK-SS	82895	111	NS6DV-48-24.625-A45	26719	162	PAB	75513	103
MHS-P2400S/S*	77516	74	MR-1050PG	A2840	123	NS6DV-48-24.625-A45	26719	162	PAB	75513	117
MHS-P2400S/S*	77516	76	MR-1200PG	A2841	123	NS6DV-54-27.625-A45	26720	160	PAB-S/S	75515	64
MHS-P600*	77499	69	MR-1500PG	A2829	123	NS6DV-54-27.625-A45	26720	162	PAB-S/S	75515	66
MHS-P600*	77499	74	MR-1600PG	A2830	123	NS6DV-60-30.625-A45	26721	160	PAB-S/S	75515	74
MHS-P600*	77499	76	MR-1800PG	A2831	123	NS6DV-60-30.625-A45	26721	162	PAB-S/S	75515	85
MHS-P600S/S*	77508	69	MR-2100PG	A2832	123	NS6DV-72-36.625-A45	26722	162	PAB-S/S	75515	92
MHS-P600S/S*	77508	74	MR-2400PG	A2833	123	NS6DV-72-36.625-A45	26722	162	PAB-S/S	75515	105
MHS-P600S/S*	77508	76	MR-2600PG	A2834	123	NS7DV-48-24.625-A105	26723	160	PACB100	79656	72
MHS-P750*	77500	69	MR-3000PG	A2835	123	NS7DV-54-27.625-A105	26724	160	PACB100	79656	77
MHS-P750*	77500	74	MR-450PG	A2836	123	NS7DV-60-30.625-A105	26725	160	PACB100	79656	97
MHS-P750*	77500	76	MR-600PG	A2837	123	NS7DV-72-36.625-A105	26726	160	PACB60	78683	72
MHS-P750S/S*	77509	69	MR-750PG	A2838	123	NS7DV-84-42.625-A105	26727	160	PACB60	78683	77
MHS-P750S/S*	77509	74	MR-900PG	A2839	123	NS7DV-96-48.625-A105	26728	160	PACB60	78683	97
MHS-P750S/S*	77509	76	MSPBPK-S/S	77583	18	NS7EV-48-24.625-A105	26723	162	PAT1	78684	29
MHS-P900*	77501	69	MSPMPK	75811	25	NS7EV-54-27.625-A105	26724	162	PAT2	78685	29
MHS-P900*	77501	74	MSPMPK-S/S	77582	27	NS7EV-60-30.625-A105	26725	162	PATHK	78794	29
MHS-P900S/S*	77510	69	MSR	74914	163	NS7EV-72-36.625-A105	26726	162	PATLK	78791	29
MHS-P900S/S*	77510	74	MSR	74914	165	NS7EV-84-42.625-A105	26727	162	PBC-1	61356	169
MHS-P900S/S*	77510	76	MSR-S/S	79378	164	NS7EV-96-48.625-A105	26728	162	PBC-2	61357	169
MHS-P900S/S*	77510	76	MSR-S/S	64924	165	OIBBK	76950	142	PBC-FR	61358	169
MMBK	75830	127	MST-MBL	79436	72	P-CARK-V24/600	78080	81	PCAP-24/600	77913	83
MMKU	77324	110	MST-MBR	79437	72	P-CARK-V24/600-S/S			PCAP-24/600-S/S	78355	85
MMKU-SS	77357	111				PVECKS/S	82815	81	PCAP-30/750	77914	83
						P-CARK-V30/750	78081	81	PCAP-30/750-S/S	78356	85

INDEX By Ordering Number

Ordering Number	Item Code	Page #	Ordering Number	Item Code	Page #	Ordering Number	Item Code	Page #	Ordering Number	Item Code	Page #
PCAP-36/900	77915	83	PP1400	73015	64	PTEZ-1050	90269	153	PTM-2600-1		163
PCAP-36/900-S/S	78357	85	PP1400-S/S	75388	64	PTEZ-1200	90270	153	PTM-2600-1-S/S		164
PCAP-42/1050	77916	83	PP1500	73016	64	PTEZ-450	90265	153	PTM-2600-2		163
PCAP-42/1050-S/S	78358	85	PP1500-S/S	75389	64	PTEZ-600	90266	153	PTM-2600-2-S/S		164
PCAP-48/1200	77917	83	PP450	73003	64	PTEZ-750	90267	153	PTM-2600-3		163
PCAP-48/1200-S/S	78359	85	PP450-S/S	75382	64	PTEZ-900	90268	153	PTM-2600-3-S/S		164
PCAP-54/1350	77918	83	PP600	73005	64	PTEZDC	90353	153	PTM-3000-1		163
PCAP-54/1350-S/S	78360	85	PP600-S/S	75383	64	PTEZHD-1050	90616	153	PTM-3000-1-S/S		164
PCAP-60/1500	77919	83	PP750	73007	64	PTEZHD-1200	90617	153	PTM-3000-2		163
PCAP-60/1500-S/S	78361	85	PP750-S/S	75384	64	PTEZHD-1350	90618	153	PTM-3000-2-S/S		164
PCAP-72/1800	77920	83	PP900	73009	64	PTEZHD-1500	90795	153	PTM-3000-3		163
PCAP-72/1800-S/S	78362	85	PP900-S/S	75385	64	PTEZHD-1500	90619	153	PTM-3000-3-S/S		164
PCB	75507	61	PPHD1800	74597	64	PTEZHD-1600	90796	153	PTM-750-1		163
PFC-P-S/S	79289	64	PPHD1800-S/S	A1781	64	PTEZHD-1800	90620	153	PTM-750-1-S/S		164
PHA	73626	64	PPHD2000	74556	64	PTEZHD-2000	90797	153	PTM-750-2		163
PHA	73626	83	PPHD2000 -S/S	A2120	64	PTEZHD-2100	90621	153	PTM-750-2-S/S		164
PHDCB	75510	62	PPHD2100	A2803	64	PTEZHDB-2	90803	153	PTM-750-3		163
PHSC-S/S	73433	64	PPHD2100 -S/S	A1613	64	PTEZHDBB-2	90807	153	PTM-750-3-S/S		164
PHSC-S/S	73433	85	PPHD2400	74557	64	PTEZHDDC-2	90805	153	PTM-900-1		163
PHSC-S/S	73433	122	PPHD2400 -S/S	A1775	64	PTEZHDPB-2	90804	153	PTM-900-1-S/S		164
PIHMK	73160	62	PPS6	73024	64	PTEZHDWRB-2	90806	153	PTM-900-2		163
PMB	75895	32	PS1050	73543	122	PTEZMB +A4431:D4439	90351	153	PTM-900-2-S/S		164
PMBL	75516	83	PS1050PL*	73585	122	PTEZPB	90352	153	PTM-900-3		163
PMBL	75516	90	PS1200	73544	122	PTM-1050-1		163	PTM-900-3-S/S		164
PMBL	75516	103	PS1200PL*	73586	122	PTM-1050-1-S/S		164	PTMSR	A0235	163
PMBL	75516	117	PS1400	73546	122	PTM-1050-2		163	PTP-EBKR	79484	162
PMBL (left)	75516	61	PS1400PL*	73587	122	PTM-1050-2-S/S		164	PTP-HDEBKR	79486	162
PMBL (left)	75516	62	PS1500	73545	122	PTM-1050-3		163	PTP-HDRBK	79492	162
PMBL (left)	75516	64	PS1500PL*	73588	122	PTM-1050-3-S/S		164	PTP-HDRPA	79478	162
PMBL (left)	75516	66	PS1800	73537	122	PTM-1200-1		163	PTP-LS	79488	162
PMBL (left)	75516	74	PS1800PL*	74049	122	PTM-1200-1-S/S		164	PTP-RMB	79490	162
PMBL (right)	75519	64	PS2000	73539	122	PTM-1200-2		163	PTP-RPA	79476	162
PMBL (right)	75519	66	PS2000 PL*	74050	122	PTM-1200-2-S/S		164	PTP-RRB	79491	162
PMBL (right)	75519	74	PS600	73014	122	PTM-1200-3		163	PTP18R	79267	160
PMBL-S/S	75518	72	PS600PL*	73582	122	PTM-1200-3-S/S		164	PTP24R	79268	160
PMBL-S/S	75518	77	PS750	73541	122	PTM-1350-1		163	PTP30R	79269	160
PMBL-S/S	75518	85	PS750PL*	73583	122	PTM-1350-1-S/S		164	PTP36R	79270	160
PMBL-S/S	75518	92	PS900	73542	122	PTM-1350-2		163	PTP42R	79271	160
PMBL-S/S	75518	97	PS900PL*	73584	122	PTM-1350-2-S/S		164	PTP48R	79272	160
PMBL-S/S	75518	105	PSA150	73156	64	PTM-1350-3		163	PTP54R	79273	160
PMBL-S/S (left)	75518	64	PSA150	73156	83	PTM-1350-3-S/S		164	PTP60R	79274	160
PMBL-S/S (left)	75518	66	PSA150 (V-Tip)	73156	80	PTM-1500-1		163	PTP72R	79275	160
PMBL-S/S (left)	75518	74	PSN11010	74053	122	PTM-1500-2		163	PTPHD48R	79276	160
PMBL-S/S (right)	75521	64	PSR-L	74560	151	PTM-1500-3		163	PTPHD54R	79277	160
PMBL-S/S (right)	75521	66	PSR-L-F	62352	151	PTM-1600-1		163	PTPHD60R	79278	160
PMBL-S/S (right)	75521	74	PSR-M	74559	151	PTM-1600-1-S/S		164	PTPHD72R	79279	160
PMBR	75519	83	PSR-M-F	62351	151	PTM-1600-2		163	PTPHD84R	79280	160
PMBR	75519	90	PSR-S	74558	151	PTM-1600-2-S/S		164	PTPHD96R	79281	160
PMBR	75519	103	PSR-S-F	62350	151	PTM-1600-3		163	PTPK	75897	32
PMBR	75519	117	PSR-XL	74561	151	PTM-1600-3-S/S		164	PTPK-MT	82343	110
PMBR (right)	75519	61	PSR-XL-F	62353	151	PTM-1800-1		163	PTPK-MT-S/S	82342	111
PMBR (right)	75519	62	PSSS	74773	64	PTM-1800-1-S/S		164	PTPLB	79470	162
PMBR-S/S	75521	72	PSSS-H	73222	122	PTM-1800-2		163	PTPLB-HD	79473	162
PMBR-S/S	75521	77	PSSS-N	73221	122	PTM-1800-2-S/S		164	PTS-18R	77664	157
PMBR-S/S	75521	85	PST-S	75894	32	PTM-1800-3		163	PTS-24R	77665	157
PMBR-S/S	75521	92	PST-W	75893	32	PTM-1800-3-S/S		164	PTS-30R	77666	157
PMBR-S/S	75521	97	PSTA	75896	25	PTM-2000-1		163	PTS-36R	77667	157
PMBR-S/S	75521	105	PSTA	75896	32	PTM-2000-1-S/S		164	PTS-42R	77668	157
PMR-CHB-L60	61073	123	PSTA-S/S	77442	27	PTM-2000-2		163	PTS-48R	77669	157
PMR-CHB-L73	61075	123	PSTS-S	75899	32	PTM-2000-2-S/S		164	PTS-54R	77670	157
PMR-CHB-R60	61074	123	PSTS-S	75899	35	PTM-2000-3		163	PTS-60R	77671	157
PMR-CHB-R73	61076	123	PSTS-S	75899	55	PTM-2000-3-S/S		164	PTS-72R	77672	157
PMSMK	74916	165	PSTS-S-S/S	79056	55	PTM-2400-1		163	PTS-ABK	77693	158
PMSMK-S/S	64925	165	PSTS-W	75898	25	PTM-2400-1-S/S		164	PTS-EBK	77702	158
PP1050	73011	64	PSTS-W	75898	32	PTM-2400-2		163	PTS-HDSR	77692	158
PP1050-S/S	75386	64	PSTS-W	75898	35	PTM-2400-2-S/S		164	PTS-HIBK	77697	158
PP1200	73013	64	PSTS-W	75898	110	PTM-2400-3		163	PTS-IBK	77696	158
PP1200-S/S	75387	64	PSVA	73434	122	PTM-2400-3-S/S		164	PTS-LHSAA	77756	158

INDEX By Ordering Number

Ordering Number	Item Code	Page #	Ordering Number	Item Code	Page #	Ordering Number	Item Code	Page #	Ordering Number	Item Code	Page #
PTS-MBK	77700	158	PVT6-S/S	75420	64	R-CARK2-V72/1800	78120	88	RP900-S/S	75403	66
PTS-MBKUG	77701	158	PVT6-S/S	75420	85	R-CARK2-V72/1800-S/S			RPHD1800	74613	66
PTS-PA	77699	158	PVT6-S/S	75420	122	RV2ECKSS	82837	88	RPHD1800-S/S	A1575	66
PTS-PS	77698	158	QMT-G	76483	25	R-CARK2-V84/2100	78121	88	RPHD2000	74614	66
PTS-RHSAA	77755	158	QMT-G	76484	110	R-CARK2-V84/2100-S/S			RPHD2000-S/S	61270	66
PTS-RR21	77680	157	QMT-G-S/S	77586	27	RV2ECKSS	82838	88	RPHD2100	A2527	66
PTS-RR27	77681	157	QMT-P	76074	25	R-CARK2-V96/2400	78122	88	RPHD2100-S/S	A1629	66
PTS-RR33	77682	157	QMT-P-S/S	77584	27	R-CARK2-V96/2400-S/S			RPHD2400	74615	66
PTS-RR39	77683	157	QMT-W	76075	25	RV2ECKSS	82839	88	RPHD2400-S/S	61271	66
PTS-RR45	77684	157	QMT-W-S/S	77585	27	RBPCP	73162	152	RSA	76249	66
PTS-RR51	77685	157	QMTBK-G	76540	25	RBPFK-L	73948	152	RSA150	76249	90
PTS-RR57	77686	157	QMTBK-G	76540	27	RBPFK-M	73947	152	RSA150	73628	66
PTS-RR63	77687	157	QMTBK-GCN	82174	110	RBPFK-S	73946	152	RSA150	73628	67
PTS-RR75	77689	157	QMTBK-GCN	82174	111	RBPFK-XL	73949	152	RSA150	73628	69
PTS-SAK	77694	158	QMTBK-P	76097	25	RBPMBK	74327	152	RSA150	73628	74
PTS-SR	77691	158	QMTBK-P	76097	27	RBPRET	A1622	152	RSA150	73628	76
PU150	73020	64	QMTBK-W	76098	25	RBPRET	73163	158	RSA150	73628	90
PV1050	73010	63	QMTBK-W	76098	27	RBPSR-L	74564	152	RSA150	73628	96
PV1050-S/S	75327	63	QMTBK-W	76098	32	RBPSR-L-CCT	28253	152	RSA150	73628	103
PV1050-SAC	78023	80	QMTBK-W	76098	35	RBPSR-M	74563	152	RSA150	73628	87
PV1050-SAC-S/S	78332	80	QMTBK-WS-MT	82175	110	RBPSR-M-CCT	29135	152	RSA150 (V-Tip)	73628	94
PV1200	73012	63	QMTBK-WS-MT	82175	111	RBPSR-S	74562	152	RSA150 (V-Tip)	73628	101
PV1200-S/S	75328	63	QMTPAK	76096	25	RBPSR-S-CCT	28250	152	RSA150-EL	61141	67
PV1200-SAC	78024	80	QMTPAK-S/S	77587	27	RBPSR-XL	74565	152	RSA150-EL	61141	67
PV1200-SAC-S/S	78333	80	QMTPSBK	76099	25	RBPSR-XL-CCT	28254	152	RSA150-EL	61141	69
PV1350-SAC	78025	80	QMTPSBK-CN	82182	110	RC-S/S	76250	66	RSA150-EL	61141	69
PV1350-SAC-S/S	78334	80	QMTPSBK-S/S	77588	27	RC-S/S	76250	92	RSA150-EL	61141	69
PV1400	73436	63	QMTS-G	76484	25	RCAP-24/600	77921	90	RV1050	74637	65
PV1400-S/S	75329	63	QMTS-G-S/S	77452	18	RCAP-24/600-S/S	78363	92	RV1050-S/S	75345	65
PV1500	73437	63	QMTS-G-S/S	77452	27	RCAP-30/750	77922	90	RV1050-SAC	78036	87
PV1500-2SAC	78028	80	QMTS-G-SS	77452	111	RCAP-30/750-S/S	78364	92	RV1050-SAC-S/S	78345	87
PV1500-2SAC-S/S	78337	80	QMTS-P	75845	17	RCAP-36/900	77923	90	RV1200	74638	65
PV1500-S/S	75330	63	QMTS-P	75845	25	RCAP-36/900-S/S	78365	92	RV1200-S/S	75346	65
PV1500-SAC	78026	80	QMTS-P	75845	110	RCAP-42/1050	77924	90	RV1200-SAC	78037	87
PV1500-SAC-S/S	78335	80	QMTS-P-S/S	77450	18	RCAP-42/1050-S/S	78366	92	RV1200-SAC-S/S	78346	87
PV1800-2SAC	78029	80	QMTS-P-S/S	77450	27	RCAP-48/1200	77925	90	RV1350-SAC	78038	87
PV1800-2SAC-S/S	78338	80	QMTS-P-SS	77450	111	RCAP-48/1200-S/S	78367	92	RV1350-SAC-S/S	78347	87
PV1800-SAC	78027	80	QMTS-W-S/S	77451	18	RCAP-54/1350	77926	90	RV1400	74639	65
PV1800-SAC-S/S	78336	80	QMTS-W-SS	77451	111	RCAP-54/1350-S/S	78368	92	RV1400-S/S	75347	65
PV1950-2SAC-S/S	78656	80	QSTS-W-S/S	77451	27	RCAP-60/1500	77927	90	RV1500	74640	65
PV2100-2SAC	78030	80	R-CARK-V24/600	78106	88	RCAP-60/1500-S/S	78369	92	RV1500-2SAC	78041	87
PV2100-2SAC-S/S	78339	80	R-CARK-V24/600-S/S			RCAP-72/1800	77928	90	RV1500-2SAC-S/S	78350	87
PV2400-2SAC	78031	80	RVECKS/S	82828	88	RCAP-72/1800-S/S	78370	92	RV1500-S/S	75348	65
PV2400-2SAC-S/S	78340	80	R-CARK-V30/750	78107	88	RIBBK	81250	130	RV1500-SAC	78039	87
PV3000-2SAC	78032	80	R-CARK-V30/750-S/S			RIBBK	81250	132	RV1500-SAC-S/S	78348	87
PV3000-2SAC-S/S	78341	80	RVECKS/S	82829	88	RIBBK	81250	134	RV1800-2SAC	78042	87
PV450	73435	63	R-CARK-V36/900	78108	88	RIBBK	81250	136	RV1800-2SAC-S/S	78351	87
PV450-S/S	75323	63	R-CARK-V36/900-S/S			RMC-FS	76558	167	RV1800-SAC	78040	87
PV600	73004	63	RVECKS/S	82830	88	RMC1-BPP	76415	167	RV1800-SAC-S/S	78349	87
PV600-S/S	75324	63	R-CARK-V42/1050	78109	88	RMC1-CB	75817	167	RV1950-2SAC-S/S	78663	87
PV600-SAC	78020	80	R-CARK-V42/1050-S/S			RMC1-PP	75832	167	RV2100-2SAC	78043	87
PV600-SAC-S/S	78329	80	RVECKS/S	82831	88	RMC2-AP	76559	167	RV2100-2SAC-S/S	78352	87
PV750	73006	63	R-CARK-V48/1200	78110	88	RMC2-AP-S/S	A2704	167	RV2400-2SAC	78044	87
PV750-S/S	75325	63	R-CARK-V48/1200-S/S			RP1050	74608	66	RV2400-2SAC-S/S	78353	87
PV750-SAC	78021	80	RVECKS/S	82832	88	RP1050-S/S	75404	66	RV3000-2SAC	78045	87
PV750-SAC-S/S	78330	80	R-CARK-V54/1350	78111	88	RP1200	74609	66	RV3000-2SAC-S/S	78354	87
PV900	73008	63	R-CARK-V54/1350-S/S			RP1200-S/S	75405	66	RV450	74633	65
PV900-S/S	75326	63	RVECKS/S	82833	88	RP1400	74610	66	RV450-S/S	75341	65
PV900-SAC	78022	80	R-CARK-V60/1500	78112	88	RP1400-S/S	75406	66	RV600	74634	65
PV900-SAC-S/S	78331	80	R-CARK-V60/1500-S/S			RP1500	74611	66	RV600-S/S	75342	65
PVHD1800	74598	63	RVECKS/S	82834	88	RP1500-S/S	75407	66	RV600-SAC	78033	87
PVHD1800-S/S	A1603	63	R-CARK-V72/1800	78113	88	RP450	74604	66	RV600-SAC-S/S	78342	87
PVHD2000	75452	63	R-CARK-V72/1800-S/S			RP450-S/S	75400	66	RV750	74635	65
PVHD2000-S/S	A2046	63	RVECKS/S	82835	88	RP600	74605	66	RV750-S/S	75343	65
PVHD2100	74553	63	R-CARK2-V120/3000	78123	88	RP600-S/S	75401	66	RV750-SAC	78034	87
PVHD2100-S/S	A1604	63	R-CARK2-V120/3000-S/S			RP750	74606	66	RV750-SAC-S/S	78343	87
PVHD2400	74555	63	RV2ECKSS	82840	88	RP750-S/S	75402	66	RV900	74636	65
PVHD2400-S/S	A1605	63	R-CARK2-V60/1500	78119	88	RP900	74607	66	RV900-S/S	75344	65
			R-CARK2-V60/1500-S/S						RV900-SAC	78035	87
			RV2ECKSS	82836	88						

INDEX By Ordering Number

Ordering Number	Item Code	Page #	Ordering Number	Item Code	Page #	Ordering Number	Item Code	Page #	Ordering Number	Item Code	Page #
RV900-SAC-S/S	78344	87	SACPL-48/1200	77891	103	SACPL2-96/2400	77898	103	SCU60	82812	110
RVHD1800	74642	65	SACPL-48/1200-S/S	78375	84	SACPL2-96/2400-S/S	78382	84	SCU60-S/S	82810	111
RVHD1800-S/S	A1626	65	SACPL-48/1200-S/S	78375	91	SACPL2-96/2400-S/S	78382	91	SCUHD	82813	110
RVHD2000	75463	65	SACPL-48/1200-S/S	78375	98	SACPL2-96/2400-S/S	78382	98	SCUHD-S/S	82811	111
RVHD2100	74643	65	SACPL-48/1200-S/S	78375	104	SACPL2-96/2400-S/S	78382	104	SHIM-KITH	77550	140
RVHD2100-S/S	A1628	65	SACPL-54/1350	77892	82	SACRH	77883	47	SHIM-KITL	77548	138
RVHD2400	74644	65	SACPL-54/1350	77892	89	SACRH	77883	83	SHIM-KITM	77549	139
RVHD2400-S/S	A1610	65	SACPL-54/1350	77892	96	SACRH	77883	90	SHIM-LDKIT	82393	130
RVT6-S/S	76205	66	SACPL-54/1350	77892	103	SACRH	77883	97	SHIM-LDKIT	82393	132
RVT6-S/S	76205	67	SACPL-54/1350-S/S	78376	84	SACRH	77883	103	SHIM-LDKIT	82393	134
RVT6-S/S	76205	69	SACPL-54/1350-S/S	78376	91	SACRH-S/S	78397	85	SHIM-MDKIT	82394	136
RVT6-S/S	76205	74	SACPL-54/1350-S/S	78376	98	SACRH-S/S	78397	92	SKPU-10X1/2X25	91311	168
RVT6-S/S	76205	76	SACPL-54/1350-S/S	78376	104	SACRH-S/S	78397	99	SKPU-10X1/2X50	91316	168
RVT6-S/S	76205	92	SACPL-60/1500	77893	82	SACRH-S/S	78397	105	SKPU-10X1X25	91314	168
RVT6-S/S	76205	99	SACPL-60/1500	77893	89	SACRHL	77884	47	SKPU-10X1X50	91319	168
RVT6-S/S	76205	105	SACPL-60/1500	77893	96	SACRHL	77884	83	SKPU-10X3/4X25	91313	168
SAC2-TIP-TL	77866	83	SACPL-60/1500	77893	103	SACRHL	77884	90	SKPU-10X3/4X50	91318	168
SAC2-TIP-TL	77866	85	SACPL-60/1500-S/S	78377	84	SACRHL	77884	97	SKPU-10X3/8X25	91310	168
SAC2-TIP-TL	77866	90	SACPL-60/1500-S/S	78377	91	SACRHL	77884	103	SKPU-10X3/8X50	91315	168
SAC2-TIP-TL	77866	92	SACPL-60/1500-S/S	78377	98	SACRHL-S/S	78398	85	SKPU-10X5/8X25	91312	168
SAC2-TIP-TL	77866	97	SACPL-60/1500-S/S	78377	104	SACRHL-S/S	78398	92	SKPU-10X5/8X50	91317	168
SAC2-TIP-TL	77866	99	SACPL-72/1800	77894	82	SACRHL-S/S	78398	99	SKPU-12X1/2X25	91321	168
SAC2-TIP-TL	77866	103	SACPL-72/1800	77894	89	SACRHL-S/S	78398	105	SKPU-12X1/2X50	91326	168
SAC2-TIP-TL	77866	105	SACPL-72/1800	77894	96	SACRKN	77882	47	SKPU-12X1X25	91324	168
SACKRP	77885	47	SACPL-72/1800	77894	103	SACRKN	77882	83	SKPU-12X1X50	91329	168
SACKRP	77885	83	SACPL-72/1800-S/S	78378	84	SACRKN	77882	85	SKPU-12X3/4X25	91323	168
SACKRP	77885	90	SACPL-72/1800-S/S	78378	91	SACRKN	77882	90	SKPU-12X3/4X50	91328	168
SACKRP	77885	97	SACPL-72/1800-S/S	78378	98	SACRKN	77882	92	SKPU-12X3/8X25	91320	168
SACKRP	77885	103	SACPL-72/1800-S/S	78378	104	SACRKN	77882	97	SKPU-12X3/8X50	91325	168
SACKRP-S/S	78399	85	SACPL2-120/3000	77899	82	SACRKN	77882	99	SKPU-12X5/8X25	91322	168
SACKRP-S/S	78399	92	SACPL2-120/3000	77899	89	SACRKN	77882	103	SKPU-12X5/8X50	91327	168
SACKRP-S/S	78399	99	SACPL2-120/3000	77899	96	SACRKN	77882	105	SKPU-4X1/2X25	91289	168
SACKRP-S/S	78399	105	SACPL2-120/3000	77899	103	SACRKT	77886	83	SKPU-4X1/2X50	91294	168
SACPL-24/600	77887	82	SACPL2-120/3000-S/S	78383	84	SACRKT	77886	90	SKPU-4X1X25	91292	168
SACPL-24/600	77887	89	SACPL2-120/3000-S/S	78383	91	SACRKT	77886	97	SKPU-4X1X50	91297	168
SACPL-24/600	77887	96	SACPL2-120/3000-S/S	78383	98	SACRKT	77886	103	SKPU-4X3/4X25	91291	168
SACPL-24/600	77887	103	SACPL2-120/3000-S/S	78383	104	SACRKT-S/S	78401	85	SKPU-4X3/4X50	91296	168
SACPL-24/600-S/S	78371	84	SACPL2-60/1500	77895	82	SACRKT-S/S	78401	92	SKPU-4X3/8X25	91288	168
SACPL-24/600-S/S	78371	91	SACPL2-60/1500	77895	89	SACRKT-S/S	78401	99	SKPU-4X3/8X50	91293	168
SACPL-24/600-S/S	78371	98	SACPL2-60/1500	77895	96	SACRKT-S/S	78401	105	SKPU-4X5/8X25	91290	168
SACPL-24/600-S/S	78371	104	SACPL2-60/1500	77895	103	SACSK	77052	97	SKPU-4X5/8X50	91295	168
SACPL-30/750	77888	82	SACPL2-60/1500-S/S	78379	84	SACSK	77052	99	SKPU-6X1/2X25	90283	168
SACPL-30/750	77888	89	SACPL2-60/1500-S/S	78379	91	SACSRC	77065	97	SKPU-6X1/2X50	91222	168
SACPL-30/750	77888	96	SACPL2-60/1500-S/S	78379	98	SACSRC	77065	99	SKPU-6X1X25	91300	168
SACPL-30/750	77888	103	SACPL2-60/1500-S/S	78379	104	SB1050-SEC	61066	121	SKPU-6X1X50	91303	168
SACPL-30/750-S/S	78372	84	SACPL2-72/1800	77896	82	SB1050A	A0435	121	SKPU-6X3/4X25	90284	168
SACPL-30/750-S/S	78372	91	SACPL2-72/1800	77896	89	SB1200-SEC	61067	121	SKPU-6X3/4X50	91223	168
SACPL-30/750-S/S	78372	98	SACPL2-72/1800	77896	96	SB1200A	A0316	121	SKPU-6X3/8X25	91298	168
SACPL-30/750-S/S	78372	104	SACPL2-72/1800	77896	103	SB1400-SEC	61068	121	SKPU-6X3/8X50	91301	168
SACPL-36/900	77889	82	SACPL2-72/1800-S/S	78380	84	SB1400A	A1620	121	SKPU-6X5/8X25	91299	168
SACPL-36/900	77889	89	SACPL2-72/1800-S/S	78380	91	SB1500-SEC	61069	121	SKPU-6X5/8X50	91302	168
SACPL-36/900	77889	96	SACPL2-72/1800-S/S	78380	98	SB1500A	A1838	121	SKPU-8X1/2X25	90285	168
SACPL-36/900	77889	103	SACPL2-72/1800-S/S	78380	104	SB1800-SEC	61070	121	SKPU-8X1/2X50	91224	168
SACPL-36/900-S/S	78373	84	SACPL2-78/1950-S/S	78642	84	SB1800A	A1357	121	SKPU-8X1X25	91306	168
SACPL-36/900-S/S	78373	91	SACPL2-78/1950-S/S	78642	91	SB4	78789	130	SKPU-8X1X50	91309	168
SACPL-36/900-S/S	78373	98	SACPL2-78/1950-S/S	78642	98	SB4	78789	132	SKPU-8X3/4X25	90286	168
SACPL-36/900-S/S	78373	104	SACPL2-78/1950-S/S	78642	104	SB4	78789	134	SKPU-8X3/4X50	91225	168
SACPL-42/1050	77890	82	SACPL2-84/2100	77897	82	SB4	78789	136	SKPU-8X3/8X25	91304	168
SACPL-42/1050	77890	89	SACPL2-84/2100	77897	89	SB5	78790	130	SKPU-8X3/8X50	91307	168
SACPL-42/1050	77890	96	SACPL2-84/2100	77897	96	SB5	78790	132	SKPU-8X5/8X25	91305	168
SACPL-42/1050	77890	103	SACPL2-84/2100	77897	103	SB5	78790	134	SKPU-8X5/8X50	91308	168
SACPL-42/1050-S/S	78374	84	SACPL2-84/2100-S/S	78381	84	SB5	78790	136	SMR-CCB-L60	A2844	123
SACPL-42/1050-S/S	78374	91	SACPL2-84/2100-S/S	78381	91	SB600-SEC	61063	121	SMR-CCB-L73	A2842	83
SACPL-42/1050-S/S	78374	98	SACPL2-84/2100-S/S	78381	98	SB600A	A0887	121	SMR-CCB-L73	A2842	90
SACPL-42/1050-S/S	78374	104	SACPL2-84/2100-S/S	78381	104	SB750-SEC	61064	121	SMR-CCB-L73	A2842	103
SACPL-48/1200	77891	82	SACPL2-96/2400	77898	82	SB750A	A0407	121	SMR-CCB-L73	A2842	123
SACPL-48/1200	77891	89	SACPL2-96/2400	77898	89	SB900-SEC	61065	121	SMR-CCB-R60	A2845	123
SACPL-48/1200	77891	96	SACPL2-96/2400	77898	96	SB900A	A0912	121	SMR-CCB-R73	A2843	83

INDEX By Ordering Number

Ordering Number	Item Code	Page #	Ordering Number	Item Code	Page #	Ordering Number	Item Code	Page #	Ordering Number	Item Code	Page #
SMR-CCB-R73	A2843	90	SSTOTA	76073	127	TEN-LOCK-KIT	77443	22	URCB60/1500	76755	112
SMR-CCB-R73	A2843	103	SSTSMB	76071	127	TEN-LOCK-KIT	77443	79	URCB64/1600	77318	112
SMR-CCB-R73	A2843	123	STAK	75847	76	TEN-LOCK-KIT	77443	107	URCB72/1800	76756	112
SPFC	79200	74	STAK	75847	76	TRB18	76485	23	URCB80/2000	77321	112
SPFC	79200	76	STAK	75847	97	TRB18	76485	25	URCB84/2100	76757	112
SPFC	79200	96	STAK	75847	99	TRB18	76485	27	URCB88/2200	76319	112
SPFC	79200	103	STAKHD	75892	76	TRB24	76486	23	URCB94/2400	77448	112
SPFC-S/S	79201	74	STAKHD	75892	76	TRB24	76486	25	URCB98/2500	77449	112
SPFC-S/S	79201	76	STAKHD	75892	97	TRB24	76486	27	URVB18/450	76736	108
SPFC-S/S	79201	99	STAKHD	75892	99	TRB30	76487	23	URVB18/450	76736	108
SPFC-S/S	79201	105	STCK	74506	42	TRB30	76487	25	URVB18/450	76736	109
SPG-CVR-A	77387	22	STCK-S/S	75425	42	TRB30	76487	27	URVB18/450	76736	109
SPG-CVR-A	77387	79	STGK2	77635	76	TRB36	76488	23	URVB18/450	76736	112
SPG-CVR-A	77387	107	STGK2	77635	76	TRB36	76488	25	URVB24/600	76737	108
SPG-CVR-B	77388	22	STGK2	77635	97	TRB36	76488	27	URVB24/600	76737	108
SPG-CVR-B	77388	79	STGK2	77635	99	TRB42	76489	23	URVB24/600	76737	109
SPG-CVR-B	77388	107	STHDMK2-S/S	77634	76	TRB42	76489	25	URVB24/600	76737	109
SPG-CVR-C	77389	22	STHDMK2-S/S	77634	99	TRB42	76489	27	URVB24/600	76737	112
SPG-CVR-C	77389	79	STHDPM2-S/S	77633	76	TRB48	76490	23	URVB30/750	76738	108
SPG-CVR-C	77389	107	STHDPM2-S/S	77633	99	TRB48	76490	25	URVB30/750	76738	108
SPG-CVR-D	77390	22	STJK	74417	42	TRB48	76490	27	URVB30/750	76738	109
SPG-CVR-D	77390	79	STJK	74417	42	TRB54	76491	23	URVB30/750	76738	109
SPG-CVR-D	77390	107	STJK-S/S	74417	110	TRB54	76491	25	URVB30/750	76738	112
SPG-CVR-E	77391	22	STJK-S/S	74417	111	TRB54	76491	27	URVB36/900	76739	108
SPG-CVR-E	77391	79	STJM	74775	42	TRB60	76492	23	URVB36/900	76739	108
SPG-CVR-E	77391	107	STJM	74775	42	TRB60	76492	25	URVB36/900	76739	109
SPG-CVR-F	77392	22	STJM	74775	110	TRB60	76492	27	URVB36/900	76739	109
SPG-CVR-F	77392	79	STJM-S/S	75426	42	TRB66	76493	23	URVB36/900	76739	112
SPG-CVR-F	77392	107	STJM-S/S	75426	42	TRB66	76493	25	URVB42/1050	76740	108
SPG-CVR-G	77393	22	STJM-S/S	77332	111	TRB66	76493	27	URVB42/1050	76740	108
SPG-CVR-G	77393	79	STKD	74504	42	TRB72	76494	23	URVB42/1050	76740	109
SPG-CVR-G	77393	107	STKD-S/S	75427	42	TRB72	76494	25	URVB42/1050	76740	109
SPG-CVR-H	77741	79	STLP	79535	116	TRB72	76494	27	URVB42/1050	76740	112
SPG-CVR-H	77741	107	STS-B	75844	55	TRB78	76697	23	URVB48/1200	76741	108
SRBK	74941	126	STS-B	75844	55	TRB78	76697	25	URVB48/1200	76741	108
SSFRB	78456	32	STS-B	75844	62	TRB78	76697	27	URVB48/1200	76741	109
SSFRB	78456	35	STS-B	75844	69	TRB84	77047	25	URVB48/1200	76741	109
SSRB	75978	32	STS-B	75844	76	TRB84	77047	27	URVB48/1200	76741	112
SSRB	75978	35	STS-B	75844	97	TRB90	77048	25	URVB48/1350	76742	108
SST1HDM-B	78519	76	STS-B-S/S	77632	55	TRB90	77048	27	URVB54/1350	76742	108
SST1HDM-B	78519	97	STS-B-S/S	77632	55	UFB18	74448	112	URVB54/1350	76742	109
SST1HDM-B-S/S	78396	76	STS-B-S/S	77632	69	UFB24	74449	112	URVB54/1350	76742	109
SST1HDM-B-S/S	78396	99	STS-B-S/S	77632	76	UFB30	74450	112	URVB54/1350	76742	112
SST1HDM-G	79069	76	STS-B-S/S	77632	99	UFB36	74451	112	URVB56/1400	77314	108
SST1HDM-G	79069	97	STS-G	78142	55	UFB42	74452	112	URVB56/1400	77314	108
SST1HDM-S	78518	76	STS-G	78142	55	UFB48	74453	112	URVB56/1400	77314	109
SST1HDM-S	78518	97	STS-G	78142	69	UFB54	74454	112	URVB56/1400	77314	109
SST1HDM-S-S/S	78395	76	STS-G	78142	76	UFB60	74455	112	URVB56/1400	77314	112
SST1HDM-S-S/S	78395	99	STS-G	78142	97	UFB72	74456	112	URVB60/1500	76743	108
SST1HDM-W	78517	76	STS-G-S/S	79057	55	UFB84	74460	112	URVB60/1500	76743	108
SST1HDM-W	78517	97	STS-G-S/S	79057	55	UHPB	76787	110	URVB60/1500	76743	109
SST1HDM-W-S/S	78394	76	STS-G-S/S	79057	69	UHPB	76787	111	URVB60/1500	76743	109
SST1HDM-W-S/S	78394	99	STS-S	75843	62	UHPB2	79207	110	URVB60/1500	76743	112
SSTBK-B	76637	76	STS-S	75843	69	UHPB2	79207	111	URVB64/1600	77315	108
SSTBK-B	76637	76	STS-S	75843	76	UHSPK-M	82887	110	URVB64/1600	77315	108
SSTBK-B	76637	97	STS-S	75843	97	UHSPK-SS-M	82889	111	URVB64/1600	77315	109
SSTBK-B	76637	99	STS-S-S/S	77631	69	UMBK-M	82890	110	URVB64/1600	77315	109
SSTBK-W	76636	76	STS-S-S/S	77631	76	UMBK-SS-M	82891	111	URVB64/1600	77315	112
SSTBK-W	76636	76	STS-S-S/S	77631	99	UNB60	61369	42	URVB72/1800	76744	108
SSTBK-W	76636	97	STS-W	75846	69	UNB73	A2671	42	URVB72/1800	76744	108
SSTBK-W	76636	99	STS-W	75846	76	URCB18/450	76748	112	URVB72/1800	76744	109
SSTHDMK	77870	76	STS-W	75846	97	URCB24/600	76749	112	URVB72/1800	76744	109
SSTHDMK	77870	96	STS-W-S/S	77630	69	URCB30/750	76750	112	URVB72/1800	76744	112
SSTHDPM	77868	76	STS-W-S/S	77630	76	URCB36/900	76751	112	URVB80/2000	77320	108
SSTHDPM	77868	97	STS-W-S/S	77630	99	URCB42/1050	76752	112	URVB80/2000	77320	108
SSTHK	79070	76	STTS	74419	42	URCB48/1200	76753	112	URVB80/2000	77320	109
SSTHK-S/S	79071	76	STTS	74419	110	URCB54/1350	76754	112	URVB80/2000	77320	109
SSTLMB	76072	127	STTS-S/S	75585	111	URCB56/1400	77317	112	URVB80/2000	77320	112

INDEX By Ordering Number

Ordering Number	Item Code	Page #	Ordering Number	Item Code	Page #	Ordering Number	Item Code	Page #	Ordering Number	Item Code	Page #
URVB84/2100	76745	108	UST-S-MT-SS	82902	111	UTV750J-S/S	77261	109	YT-900S	83232	56
URVB84/2100	76745	108	UST-W-MT	82899	110	UTV900	77300	108	YT-C*	79574	58
URVB84/2100	76745	109	UST-W-MT-SS	82903	111	UTV900-J	77286	109	YT-HDC*	79728	58
URVB84/2100	76745	109	UTS	74420	42	UTV900-S/S	82710	108	YT-HDP*	79677	58
URVB84/2100	76745	112	UTV1050	77301	108	UTV900J-S/S	77262	109	YT-P*	79573	58
URVB88/2200	77316	108	UTV1050-J	77287	109	WCB	A0012	121	YT-TC-1050S	83245	56
URVB88/2200	77316	108	UTV1050-S/S	82711	108	WCB	A0012	122	YT-TC-1200S	83246	56
URVB88/2200	77316	109	UTV1050J-S/S	77263	109	YCART-18/450-P	79617	58	YT-TC-450S	83241	56
URVB88/2200	77316	109	UTV1200	77302	108	YCART-18/450-TC	79811	58	YT-TC-600S	83242	56
URVB88/2200	77316	112	UTV1200-J	77288	109	YCART-24/600-P	79618	58	YT-TC-750S	83243	56
URVB94/2400	77421	108	UTV1200-S/S	82712	108	YCART-24/600-TC	79812	58	YT-TC-900S	83244	56
URVB94/2400	77421	108	UTV1200J-S/S	77264	109	YCART-30/750-P	79619	58	YTA-18/450	82949	61
URVB94/2400	77421	109	UTV1350	77303	108	YCART-30/750-TC	79813	58	YTA-24/600	82950	61
URVB94/2400	77421	109	UTV1350-J	77289	109	YCART-36/900-HDP	79817	58	YTA-30/750	82951	61
URVB94/2400	77421	112	UTV1350-S/S	82713	108	YCART-36/900-HDTC	79829	58	YTA-36/900	82952	61
URVB98/2500	77422	108	UTV1350J-S/S	77265	109	YCART-36/900-P	79620	58	YTA-42/1050	82953	61
URVB98/2500	77422	108	UTV1400	77304	108	YCART-36/900-TC	79814	58	YTA-48/1200	82954	61
URVB98/2500	77422	109	UTV1400-J	77290	109	YCART-42/1050-HDP	79818	58	YTAC	79623	61
URVB98/2500	77422	109	UTV1400-S/S	82714	108	YCART-42/1050-HDTC	79830	58	YTACHD	79835	62
URVB98/2500	77422	112	UTV1400J-S/S	77266	109	YCART-42/1050-P	79621	58	YTAHD-36/900	79805	62
USP18/450	82689	110	UTV1500	77305	108	YCART-42/1050-TC	79815	58	YTAHD-42/1050	79806	62
USP18/450-S/S	77339	111	UTV1500-J	77291	109	YCART-48/1200-HDP	79819	58	YTAHD-48/1200	79807	62
USP24/600	82690	110	UTV1500-S/S	82715	108	YCART-48/1200-HDTC	79831	58	YTAHD-54/1350	79808	62
USP24/600-S/S	77340	111	UTV1500J-S/S	77267	109	YCART-48/1200-P	79622	58	YTAHD-60/1500	79809	62
USP30/750	82691	110	UTV1600	77306	108	YCART-48/1200-TC	79816	58	YTAHD-72/1800	79810	62
USP30/750-S/S	77341	111	UTV1600-J	77292	109	YCART-54/1350-HDP	79820	58	YTC-1050	83227	56
USP36/900	82692	110	UTV1600-S/S	82716	108	YCART-54/1350-HDTC	79832	58	YTC-1200	83228	56
USP36/900-S/S	77342	111	UTV1600J-S/S	77268	109	YCART-60/1500-HDP	79821	58	YTC-450	83223	56
USP42/1050	82693	110	UTV1800	77307	108	YCART-60/1500-HDTC	79833	58	YTC-600	83224	56
USP42/1050-S/S	77343	111	UTV1800-J	77293	109	YCART-72/1800-HDP	79822	58	YTC-750	83225	56
USP48/1200	82694	110	UTV1800-S/S	82717	108	YCART-72/1800-HDTC	79834	58	YTC-900	83226	56
USP48/1200-S/S	77344	111	UTV1800J-S/S	77269	109	YST-P	79837	61	YTCHD-1050	83100	57
USP54/1350	82695	110	UTV2000	77308	108	YST-S	79838	61	YTCHD-1200	83101	57
USP54/1350-S/S	77345	111	UTV2000-J	77294	109	YST-Y	79836	61	YTCHD-1350	83102	57
USP56/1400	82696	110	UTV2000-S/S	82718	108	YSTANK	79857	61	YTCHD-1500	83103	57
USP56/1400-S/S	77346	111	UTV2000J-S/S	77270	109	YSTANK	79858	62	YTCHD-1800	83105	57
USP60/1500	82697	110	UTV2100	77309	108	YSTDBK	79844	61	YTCHD-900	83099	57
USP60/1500-S/S	77347	111	UTV2100-J	77295	109	YSTGBK	79845	61	YTHD-1050S	83121	57
USP64/1600	82698	110	UTV2100-S/S	82719	108	YSTHD-BK	79842	62	YTHD-1200S	83122	57
USP64/1600-S/S	77348	111	UTV2100J-S/S	77271	109	YSTHD-BL	79841	62	YTHD-1350S	83123	57
USP72/1800	82699	110	UTV2200	77310	108	YSTHD-GR	79839	62	YTHD-1500S	83124	57
USP72/1800-S/S	77349	111	UTV2200-J	77296	109	YSTHD-S	79840	62	YTHD-1800S	83126	57
USP80/2000	82700	110	UTV2200-S/S	82720	108	YSTHDBK-B	79856	62	YTHD-900S	83120	57
USP80/2000-S/S	77350	111	UTV2200J-S/S	77272	109	YSTHDBK-W	79853	62	YTHD-TC-1050S	83135	57
USP84/2100	82701	110	UTV2400	77411	108	YSTHDDBK	79850	62	YTHD-TC-1200S	83136	57
USP84/2100-S/S	77351	111	UTV2400-J	77413	109	YSTHDGBK	79851	62	YTHD-TC-1350S	83137	57
USP88/2200	82702	110	UTV2400-S/S	82721	108	YSTHDLBK	79852	62	YTHD-TC-1500S	83138	57
USP88/2200-S/S	77352	111	UTV2400J-S/S	77417	109	YSTHDMB	79849	62	YTHD-TC-1800S	83140	57
USP94/2400	82703	110	UTV2500	77412	108	YSTHDS-BL	79798	62	YTHD-TC-900S	83134	57
USP94/2400-S/S	77419	111	UTV2500-J	77414	109	YSTHDS-GR	79797	62	YTP-18/450	82932	61
USP98/2500	82704	110	UTV2500-S/S	82722	108	YSTLBK	79846	61	YTP-24/600	82933	61
USP98/2500-S/S	77418	111	UTV2500J-S/S	77418	109	YSTMB	79843	61	YTP-30/750	82934	61
USPB	79206	110	UTV450	77297	108	YSTPHDMK	79854	62	YTP-36/900	82935	61
USPB	79206	111	UTV450-J	77283	109	YSTPMK	79848	61	YTP-42/1050	82936	61
USPB2	79206	110	UTV450-S/S	82707	108	YSTS-P	79796	61	YTP-48/1200	82937	61
USPB2	79206	111	UTV450J-S/S	77259	109	YSTS-Y	79795	61	YTPHD-36/900	83106	62
USPK	76790	110	UTV600	77298	108	YSTTBK-B	79855	61	YTPHD-42/1050	83107	62
USPK-SS-M	82888	111	UTV600-J	77284	109	YSTTBK-W	79847	61	YTPHD-48/1200	83108	62
UST-G-MT	82900	110	UTV600-S/S	82708	108	YT-1050S	83233	56	YTPHD-54/1350	83109	62
UST-G-MT-SS	82904	111	UTV600J-S/S	77260	109	YT-1200S	83234	56	YTPHD-60/1500	83110	62
UST-P-MT	82897	110	UTV750	77299	108	YT-450S	83229	56	YTPHD-72/1800	83112	62
UST-P-MT-SS	82901	111	UTV750-J	77285	109	YT-600S	83230	56			
UST-S-MT	82898	110	UTV750-S/S	82709	108	YT-750S	83231	56			

INDEX By Item Code

Item Code	Ordering Number	Page #	Item Code	Ordering Number	Page #	Item Code	Ordering Number	Page #	Item Code	Ordering Number	Page #
26107	N6D3T-24-9-A45	130	61069	SB1500-SEC	121	61537	MHCP-S/S-CK900	35	61804	FBP1200-1400-MF-S/S	148
26108	N6D3T-30-11-A45	130	61070	SB1800-SEC	121	61538	MHCP-S/S-CK1050	35	61805	FBP1500-1600-MF-S/S	148
26109	N6D3T-36-13-A45	130	61073	PMR-CHB-L60	123	61539	MHCP-S/S-CK1200	35	61806	FBP1800-2000-MF-S/S	148
26110	N6D3T-42-15-A45	130	61074	PMR-CHB-R60	123	61540	MHCP-S/S-CK1350	35	61807	FBP2200-2400-MF-S/S	148
26111	N6D3T-48-17-A45	130	61075	PMR-CHB-L73	123	61541	MHCP-S/S-CK1500	35	61808	FBP2500-2600-MF-S/S	148
26112	N6D3T-54-19-A45	130	61076	PMR-CHB-R73	123	61542	MHCP-S/S-CK1650	35	61875	FBP-NP	148
26113	N6D3T-60-21-A45	130	61077	CBD-ST-M	150	61543	MHCP-S/S-CK1800	35	61876	FBP-NP-S/S	148
26114	N6D3T-72-25-A45	130	61079	CBD-ST-M-S/S	150	61544	MHCP-S/S-CK2100	35	61877	HBP2600-PL-TP-S/S	148
26184	NI6D3T-24-9-A45	132	61080	CBD-ST-L-S/S	150	61545	MHCP-S/S-CLP	35	61882	FBP-LM	148
26185	NI6D3T-30-11-A45	132	61081	EZP1-218-S/S	15	61546	MHCP-S/S-PSTW	35	61883	FBP-LM-S/S	148
26186	NI6D3T-36-13-A45	132	61082	EZP1-224-S/S	15	61547	MHCP-S/S-PSTS	35	61888	FBP-FP	148
26187	NI6D3T-42-15-A45	132	61083	EZP1-236-S/S	15	61548	MHCP-S/S-CH	35	61889	FBP-FP-S/S	148
26188	NI6D3T-48-17-A45	132	61084	EZP1-248-S/S	15	61549	MHCP-S/S-CEB	35	61890	FBP900-1050-PP	148
26189	NI6D3T-54-19-A45	132	61085	EZP1-254-S/S	15	61550	MHCP-S/S-CBK	35	61891	FBP1200-1400-PP	148
26190	NI6D3T-60-21-A45	132	61086	EZP1-260-S/S	15	61624	MHCP-600S-S/S-FR	33	61892	FBP1500-1600-PP	148
26191	NI6D3T-72-25-A45	132	61087	EZP1-272-S/S	15	61625	MHCP-750S-S/S-FR	33	61893	FBP1800-2000-PP	148
26714	NS6DV-18-9.625-A45	160	61096	CBD-ST-AA	150	61626	MHCP-900S-S/S-FR	33	61894	FBP2200-2400-PP	148
26714	NS6DV-18-9.625-A45	162	61100	CBD-ST-HN-S/S	150	61627	MHCP-1050S-S/S-FR	33	61895	FBP2500-2600-PP	148
26715	NS6DV-24-12.625-A45	160	61105	CBD-ST-M-MF	150	61628	MHCP-1200S-S/S-FR	33	61898	FBP900-1050-PP-S/S	148
26715	NS6DV-24-12.625-A45	162	61106	CBD-ST-L-MF	150	61629	MHCP-1350S-S/S-FR	33	61899	FBP1200-1400-PP-S/S	148
26716	NS6DV-30-15.625-A45	160	61107	CBD-ST-XL-MF	150	61630	MHCP-1500S-S/S-FR	33	61900	FBP1500-1600-PP-S/S	148
26716	NS6DV-30-15.625-A45	162	61108	CBD-ST-M-MF-S/S	150	61631	MHCP-1650S-S/S-FR	33	61901	FBP1800-2000-PP-S/S	148
26717	NS6DV-36-18.625-A45	160	61109	CBD-ST-L-MF-S/S	150	61632	MHCP-1800S-S/S-FR	33	61902	FBP2200-2400-PP-S/S	148
26717	NS6DV-36-18.625-A45	162	61110	CBD-ST-XL-MF-S/S	150	61633	MHCP-2100S-S/S-FR	33	61903	FBP2500-2600-PP-S/S	148
26718	NS6DV-42-21.625-A45	160	61111	CBD-ST-FR-B	150	61634	MHCP-S/S-CP 600	35	61906	FBP900-1050-SP	148
26718	NS6DV-42-21.625-A45	162	61112	CBD-ST-M-FP	150	61750	FBP900-TP	147	61907	FBP1200-1400-SP	148
26719	NS6DV-48-24.625-A45	160	61113	CBD-ST-L-FP	150	61751	FBP1050-TP	147	61908	FBP1500-1600-SP	148
26719	NS6DV-48-24.625-A45	162	61114	CBD-ST-XL-FP	150	61752	FBP1200-TP	147	61909	FBP1800-2000-SP	148
26720	NS6DV-54-27.625-A45	160	61141	RSA150-EL	67	61753	FBP1400-TP	147	61910	FBP2200-2400-SP	148
26720	NS6DV-54-27.625-A45	162	61141	RSA150-EL	67	61754	FBP1500-TP	147	61911	FBP2500-2600-SP	148
26721	NS6DV-60-30.625-A45	160	61141	RSA150-EL	69	61755	FBP1600-TP	147	61914	FBP900-1050-SP-S/S	148
26721	NS6DV-60-30.625-A45	162	61141	RSA150-EL	69	61756	FBP1800-TP	147	61915	FBP1200-1400-SP-S/S	148
26722	NS6DV-72-36.625-A45	160	61173	HSTSS	42	61757	FBP2000-TP	147	61916	FBP1500-1600-SP-S/S	148
26722	NS6DV-72-36.625-A45	162	61182	EZP1P18-S/S	18	61758	FBP2200-TP	147	61917	FBP1800-2000-SP-S/S	148
26723	NS7DV-48-24.625-A105	160	61183	EZP1P42-S/S	18	61759	FBP2400-TP	147	61918	FBP2200-2400-SP-S/S	148
26723	NS7EV-48-24.625-A105	162	61184	EZP1P54-S/S	18	61760	FBP2500-TP	147	61919	FBP2500-2600-SP-S/S	148
26724	NS7DV-54-27.625-A105	160	61185	EZP1P60-S/S	18	61761	FBP2600-TP	147	62034	AIR HDMRK S/S	55
26724	NS7EV-54-27.625-A105	162	61186	EZP1P72-S/S	18	61765	FBP900-TP S/S	147	62035	AIR HARK-S/S-60	55
26725	NS7DV-60-30.625-A105	160	61270	RPHD2000-S/S	66	61766	FBP1050-TP S/S	147	62036	AIR BAG P	55
26725	NS7EV-60-30.625-A105	162	61271	RPHD2400-S/S	66	61767	FBP1200-TP S/S	147	62036	ATV-BAG	72
26726	NS7DV-72-36.625-A105	160	61356	PBC-1	169	61768	FBP1400-TP S/S	147	62037	ATV-NIP	55
26726	NS7EV-72-36.625-A105	162	61357	PBC-2	169	61769	FBP1500-TP S/S	147	62037	ATV-NIP	72
26727	NS7DV-84-42.625-A105	160	61358	PBC-FR	169	61770	FBP1600-TP S/S	147	62037	ATV-NIP	77
26727	NS7EV-84-42.625-A105	162	61369	UNB60	42	61771	FBP1800-TP S/S	147	62037	ATV-NIP	97
26728	NS7DV-96-48.625-A105	160	61471	FLSCM2000-S/S	166	61772	FBP2000-TP S/S	147	62079	ATV-BAG	77
26728	NS7EV-96-48.625-A105	162	61491	EZP1P48-S/S	18	61773	FBP2200-TP S/S	147	62079	ATV-BAG	97
28250	RBPSR-S-CCT	152	61504	MHCP-600S-S/S	33	61774	FBP2400-TP S/S	147	62095	CRHMK-S/S	85
28253	RBPSR-L-CCT	152	61505	MHCP-750S-S/S	33	61775	FBP2500-TP S/S	147	62095	CRHMK-S/S	92
28254	RBPSR-XL-CCT	152	61506	MHCP-900S-S/S	33	61776	FBP2600-TP S/S	147	62095	CRHMK-S/S	105
29135	RBPSR-M-CCT	152	61507	MHCP-1050S-S/S	33	61780	FBP900-B	147	62254	HVT8-EL15-S/S	53
30001	EBC-1	169	61508	MHCP-1200S-S/S	33	61781	FBP1050-B	147	62350	PSR-S-F	151
30002	EBC-2	169	61509	MHCP-1350S-S/S	33	61782	FBP1200-B	147	62351	PSR-M-F	151
30003	EBC-1-B	169	61510	MHCP-1500S-S/S	33	61783	FBP1400-B	147	62352	PSR-L-F	151
30004	EBC-2-B	169	61511	MHCP-1650S-S/S	33	61784	FBP1500-B	147	62353	PSR-XL-F	151
30018	CEBC-1	169	61512	MHCP-1800S-S/S	33	61785	FBP1600-B	147	62400	CRHMK	83
30019	CEBC-2	169	61513	MHCP-2100S-S/S	33	61786	FBP1800-B	147	62400	CRHMK	90
30033	EBC1-RK	169	61525	MHCP-S/S-CP 750	35	61787	FBP2000-B	147	62400	CRHMK	103
30034	EBC2-RK	169	61526	MHCP-S/S-CP 900	35	61788	FBP2200-B	147	62409	ATVK-60	72
61016	EZP1-242-S/S	15	61527	MHCP-S/S-CP 1050	35	61789	FBP2400-B	147	62409	ATVK-60	77
61017	EZP1-230-S/S	15	61528	MHCP-S/S-CP 1200	35	61790	FBP2500-B	147	62409	ATVK-60	97
61050	CBD-ST-L	150	61529	MHCP-S/S-CP 1350	35	61791	FBP2600-B	147	62424	ATV-MOUNT	72
61051	CBD-ST-XL	150	61530	MHCP-S/S-CP 1500	35	61795	FBP900-1050-MF	148	62424	ATV-MOUNT	77
61063	SB600-SEC	121	61531	MHCP-S/S-CP 1650	35	61796	FBP1200-1400-MF	148	62424	ATV-MOUNT	97
61064	SB750-SEC	121	61532	MHCP-S/S-CP 1800	35	61797	FBP1500-1600-MF	148	62425	ATV-SLIDE	72
61065	SB900-SEC	121	61533	MHCP-S/S-CP 2100	35	61798	FBP1800-2000-MF	148	62425	ATV-SLIDE	77
61066	SB1050-SEC	121	61534	MHCP-SS/EP	35	61799	FBP2200-2400-MF	148	62425	ATV-SLIDE	97
61067	SB1200-SEC	121	61535	MHCP-S/S-CK600	35	61800	FBP2500-2600-MF	148	62426	ATV-ANGLE	72
61068	SB1400-SEC	121	61536	MHCP-S/S-CK750	35	61803	FBP900-1050-MF-S/S	148	62426	ATV-ANGLE	77

INDEX By Item Code

Item Code	Ordering Number	Page #	Item Code	Ordering Number	Page #	Item Code	Ordering Number	Page #	Item Code	Ordering Number	Page #
62426	ATV-ANGLE	97	62506	HSA8CM	47	62538	H-CARK-600-CL	44	62605	H-CARK2-1400-CL	44
62452	H-SAC-AP-600	47	62506	HSA8CM	48	62539	H-CARK-800-CS	44	62606	H-CARK2-1400-CLL	44
62452	H-SAC-AP-600	48	62506	HSA8CM	49	62540	H-CARK-800-CM	44	62607	H-CARK2-1600-CM	44
62452	H-SAC-AP-600	48	62506	HSA8CM	53	62541	H-CARK-800-CL	44	62608	H-CARK2-1600-CL	44
62452	H-SAC-AP-600	48	62506	HSA8CM	54	62542	H-CARK-1000-CS	44	62609	H-CARK2-1600-CLL	44
62452	H-SAC-AP-600	53	62507	HSA8CL	43	62543	H-CARK-1000-CM	44	62610	H-CARK2-1800-CM	44
62452	H-SAC-AP-600	54	62507	HSA8CL	47	62544	H-CARK-1000-CL	44	62611	H-CARK2-1800-CL	44
62452	H-SAC-AP-600	54	62507	HSA8CL	48	62545	H-CARK-1200-CS	44	62612	H-CARK2-1800-CLL	44
62452	H-SAC-AP-600	54	62507	HSA8CL	49	62546	H-CARK-1200-CM	44	62613	H-CARK2-2000-CM	44
62453	H-SAC-AP-800	47	62507	HSA8CL	53	62547	H-CARK-1200-CL	44	62614	H-CARK2-2000-CL	44
62453	H-SAC-AP-800	48	62507	HSA8CL	54	62548	H-CARK-1400-CS	44	62615	H-CARK2-2000-CLL	44
62453	H-SAC-AP-800	48	62508	HSA8CLL	43	62549	H-CARK-1400-CM	44	62616	H-CARK2-2200-CM	44
62453	H-SAC-AP-800	48	62508	HSA8CLL	47	62550	H-CARK-1400-CL	44	62617	H-CARK2-2200-CL	44
62453	H-SAC-AP-800	48	62508	HSA8CLL	48	62551	H-CARK-1600-CS	44	62618	H-CARK2-2200-CLL	44
62453	H-SAC-AP-800	53	62508	HSA8CLL	49	62552	H-CARK-1600-CM	44	62619	H-CARK2-2400-CM	44
62453	H-SAC-AP-800	54	62508	HSA8CLL	53	62553	H-CARK-1600-CL	44	62620	H-CARK2-2400-CL	44
62453	H-SAC-AP-800	54	62508	HSA8CLL	54	62554	H-CARK-1800-CS	44	62621	H-CARK2-2400-CLL	44
62453	H-SAC-AP-800	54	62509	HSA8CS-S/S	45	62555	H-CARK-1800-CM	44	62622	H-CARK2-2600-CM	44
62453	H-SAC-AP-800	54	62509	HSA8CS-S/S	47	62556	H-CARK-1800-CL	44	62623	H-CARK2-2600-CL	44
62454	H-SAC-AP-1000	47	62509	HSA8CS-S/S	48	62557	HV-1200-2SAC-CS	43	62624	H-CARK2-2600-CLL	44
62454	H-SAC-AP-1000	48	62509	HSA8CS-S/S	51	62558	HV-1200-2SAC-CM	43	62625	H-CARK2-2800-CM	44
62454	H-SAC-AP-1000	48	62509	HSA8CS-S/S	53	62559	HV-1200-2SAC-CL	43	62626	H-CARK2-2800-CL	44
62454	H-SAC-AP-1000	48	62509	HSA8CS-S/S	54	62560	HV-1200-2SAC-CLL	43	62627	H-CARK2-2800-CLL	44
62454	H-SAC-AP-1000	48	62510	HSA8CM-S/S	45	62561	HV-1400-2SAC-CS	43	62628	H-CARK2-3000-CM	44
62454	H-SAC-AP-1000	53	62510	HSA8CM-S/S	47	62562	HV-1400-2SAC-CM	43	62629	H-CARK2-3000-CL	44
62454	H-SAC-AP-1000	54	62510	HSA8CM-S/S	48	62563	HV-1400-2SAC-CL	43	62630	H-CARK2-3000-CLL	44
62454	H-SAC-AP-1000	54	62510	HSA8CM-S/S	51	62564	HV-1400-2SAC-CLL	43	62631	HV-600-SAC-CS-S/S	45
62454	H-SAC-AP-1000	54	62510	HSA8CM-S/S	53	62565	HV-1600-2SAC-CM	43	62632	HV-600-SAC-CM-S/S	45
62454	H-SAC-AP-1000	54	62510	HSA8CM-S/S	54	62566	HV-1600-2SAC-CL	43	62633	HV-600-SAC-CL-S/S	45
62455	H-SAC-AP-1200	47	62511	HSA8CL-S/S	45	62567	HV-1600-2SAC-CLL	43	62634	HV-800-SAC-CS-S/S	45
62455	H-SAC-AP-1200	48	62511	HSA8CL-S/S	47	62568	HV-1800-2SAC-CM	43	62635	HV-800-SAC-CM-S/S	45
62455	H-SAC-AP-1200	48	62511	HSA8CL-S/S	48	62569	HV-1800-2SAC-CL	43	62636	HV-800-SAC-CL-S/S	45
62455	H-SAC-AP-1200	48	62511	HSA8CL-S/S	51	62570	HV-1800-2SAC-CLL	43	62637	HV-1000-SAC-CS-S/S	45
62455	H-SAC-AP-1200	48	62511	HSA8CL-S/S	53	62571	HV-2000-2SAC-CM	43	62638	HV-1000-SAC-CM-S/S	45
62455	H-SAC-AP-1200	53	62511	HSA8CL-S/S	54	62572	HV-2000-2SAC-CL	43	62639	HV-1000-SAC-CL-S/S	45
62455	H-SAC-AP-1200	54	62512	HSA8CLL-S/S	45	62573	HV-2000-2SAC-CLL	43	62640	HV-1200-SAC-CS-S/S	45
62455	H-SAC-AP-1200	54	62512	HSA8CLL-S/S	47	62574	HV-2200-2SAC-CM	43	62641	HV-1200-SAC-CM-S/S	45
62455	H-SAC-AP-1200	54	62512	HSA8CLL-S/S	48	62575	HV-2200-2SAC-CL	43	62642	HV-1200-SAC-CL-S/S	45
62455	H-SAC-AP-1200	54	62512	HSA8CLL-S/S	51	62576	HV-2200-2SAC-CLL	43	62643	HV-1400-SAC-CS-S/S	45
62456	H-SAC-AP-1400	47	62512	HSA8CLL-S/S	53	62577	HV-2400-2SAC-CM	43	62644	HV-1400-SAC-CM-S/S	45
62456	H-SAC-AP-1400	48	62512	HSA8CLL-S/S	54	62578	HV-2400-2SAC-CL	43	62645	HV-1400-SAC-CL-S/S	45
62456	H-SAC-AP-1400	48	62513	HCSBB-60	55	62579	HV-2400-2SAC-CLL	43	62646	HV-1600-SAC-CM-S/S	45
62456	H-SAC-AP-1400	48	62513	HCSBB-60	55	62580	HV-2600-2SAC-CM	43	62647	HV-1600-SAC-CL-S/S	45
62456	H-SAC-AP-1400	48	62514	HCSBB-73	55	62581	HV-2600-2SAC-CL	43	62648	HV-1600-SAC-CLL-S/S	45
62456	H-SAC-AP-1400	53	62514	HCSBB-73	55	62582	HV-1600-2SAC-CL-S/S	45	62649	HV-1800-SAC-CM-S/S	45
62456	H-SAC-AP-1400	54	62515	HV-600-SAC-CS	43	62582	HV-2600-2SAC-CLL	43	62650	HV-1800-SAC-CL-S/S	45
62456	H-SAC-AP-1400	54	62516	HV-600-SAC-CM	43	62583	HV-2800-2SAC-CM	43	62651	HV-1800-SAC-CLL-S/S	45
62456	H-SAC-AP-1400	54	62517	HV-600-SAC-CL	43	62584	HV-2800-2SAC-CL	43	62652	H CARK-600-CS-S/S	46
62456	H-SAC-AP-1400	54	62518	HV-800-SAC-CS	43	62585	HV-2800-2SAC-CLL	43	62653	H CARK-600-CM-S/S	46
62457	H-SAC-AP-1600	47	62519	HV-800-SAC-CM	43	62586	HV-3000-2SAC-CM	43	62654	H CARK-600-CL-S/S	46
62457	H-SAC-AP-1600	48	62520	HV-800-SAC-CL	43	62587	HV-3000-2SAC-CL	43	62655	H CARK-800-CS-S/S	46
62457	H-SAC-AP-1600	53	62521	HV-1000-SAC-CS	43	62588	HV-3000-2SAC-CLL	43	62656	H CARK-800-CM-S/S	46
62457	H-SAC-AP-1600	54	62522	HV-1000-SAC-CM	43	62589	HCSSB-B/G	55	62657	H CARK-800-CL-S/S	46
62458	H-SAC-AP-1800	47	62523	HV-1000-SAC-CL	43	62589	HCSSB-B/G	55	62658	H CARK-1000-CS-S/S	46
62458	H-SAC-AP-1800	53	62524	HV-1200-SAC-CS	43	62589	HCSSB-B/G	55	62659	H CARK-1000-CM-S/S	46
62494	HCSTAK	55	62525	HV-1200-SAC-CM	43	62589	HCSSB-B/G	55	62660	H CARK-1000-CL-S/S	46
62495	HCSTAK-S/S	55	62526	HV-1200-SAC-CL	43	62590	HCSSB-S	55	62661	H CARK-1200-CS-S/S	46
62496	ACME-PRK	55	62527	HV-1400-SAC-CS	43	62590	HCSSB-S	55	62662	H CARK-1200-CM-S/S	46
62496	ACME-PRK	55	62528	HV-1400-SAC-CM	43	62591	ACME-N	55	62663	H CARK-1200-CL-S/S	46
62496	ACME-PRK	55	62529	HV-1400-SAC-CL	43	62591	ACME-N	55	62664	H CARK-1400-CS-S/S	46
62496	ACME-PRK	55	62530	HV-1600-SAC-CM	43	62591	ACME-N	55	62665	H CARK-1400-CM-S/S	46
62505	HSA8CS	43	62531	HV-1600-SAC-CL	43	62591	ACME-N	55	62666	H CARK-1400-CL-S/S	46
62505	HSA8CS	47	62532	HV-1600-SAC-CLL	43	62599	H-CARK2-1200-CS	44	62667	H CARK-1600-CS-S/S	46
62505	HSA8CS	48	62533	HV-1800-SAC-CM	43	62600	H-CARK2-1200-CM	44	62668	H CARK-1600-CM-S/S	46
62505	HSA8CS	49	62534	HV-1800-SAC-CL	43	62601	H-CARK2-1200-CL	44	62669	H CARK-1600-CL-S/S	46
62505	HSA8CS	53	62535	HV-1800-SAC-CLL	43	62602	H-CARK2-1200-CLL	44	62670	H CARK-1800-CS-S/S	46
62505	HSA8CS	54	62536	H-CARK-600-CS	44	62603	H-CARK2-1400-CS	44	62671	H CARK-1800-CM-S/S	46
62506	HSA8CM	43	62537	H-CARK-600-CM	44	62604	H-CARK2-1400-CM	44	62672	H CARK-1800-CL-S/S	46

INDEX By Item Code

Item Code	Ordering Number	Page #	Item Code	Ordering Number	Page #	Item Code	Ordering Number	Page #	Item Code	Ordering Number	Page #
62673	HV-1200-2SAC-CS-S/S	45	62743	H73CSK-G	47	62768	H2CP-2400	54	63080	H73BTK-S/S	54
62674	HV-1200-2SAC-CM-S/S	45	62743	H73CSK-G	48	62769	H2CP-2600	48	63206	HV-600-SAC-CS-EL15	49
62675	HV-1200-2SAC-CL-S/S	45	62743	H73CSK-G	53	62769	H2CP-2600	54	63207	HV-600-SAC-CM-EL15	49
62676	HV-1200-2SAC-CLL-S/S	45	62743	H73CSK-G	54	62770	H2CP-2800	48	63208	HV-600-SAC-CL-EL15	49
62677	HV-1400-2SAC-CS-S/S	45	62743	H73CSK-G	55	62770	H2CP-2800	54	63209	HV-800-SAC-CS-EL15	49
62678	HV-1400-2SAC-CM-S/S	45	62744	H73CSK-G-S/S	42	62771	H2CP-3000	48	63210	HV-800-SAC-CM-EL15	49
62679	HV-1400-2SAC-CL-S/S	45	62744	H73CSK-G-S/S	47	62771	H2CP-3000	54	63211	HV-800-SAC-CL-EL15	49
62680	HV-1400-2SAC-CLL-S/S	45	62744	H73CSK-G-S/S	48	62801	H2CP-1200-S/S	48	63212	HV-1000-SAC-CS-EL15	49
62681	HV-1600-2SAC-CM-S/S	45	62744	H73CSK-G-S/S	53	62801	H2CP-1200-S/S	54	63213	HV-1000-SAC-CM-EL15	49
62683	HV-1600-2SAC-CLL-S/S	45	62744	H73CSK-G-S/S	54	62802	H2CP-1400-S/S	48	63214	HV-1000-SAC-CL-EL15	49
62684	HV-1800-2SAC-CM-S/S	45	62744	H73CSK-G-S/S	55	62802	H2CP-1400-S/S	54	63215	HV-1200-SAC-CS-EL15	49
62685	HV-1800-2SAC-CL-S/S	45	62745	H73CSK-S	48	62803	H2CP-1600-S/S	48	63216	HV-1200-SAC-CM-EL15	49
62686	HV-1800-2SAC-CLL-S/S	45	62745	H73CSK-S	54	62803	H2CP-1600-S/S	54	63217	HV-1200-SAC-CL-EL15	49
62687	HV-2000-2SAC-CM-S/S	45	62745	H73CSK-S	55	62804	H2CP-1800-S/S	48	63218	HV-1400-SAC-CS-EL15	49
62688	HV-2000-2SAC-CL-S/S	45	62746	H73CSK-S-S/S	48	62804	H2CP-1800-S/S	54	63219	HV-1400-SAC-CM-EL15	49
62689	HV-2000-2SAC-CLL-S/S	45	62746	H73CSK-S-S/S	54	62805	H2CP-2000-S/S	48	63220	HV-1400-SAC-CL-EL15	49
62690	HV-2200-2SAC-CM-S/S	45	62746	H73CSK-S-S/S	55	62805	H2CP-2000-S/S	54	63221	HV-1600-SAC-CM-EL15	49
62691	HV-2200-2SAC-CL-S/S	45	62747	H60CSK-B	55	62806	H2CP-2400-S/S	48	63222	HV-1600-SAC-CL-EL15	49
62692	HV-2200-2SAC-CLL-S/S	45	62747	HCSTK-60-B	42	62806	H2CP-2400-S/S	54	63223	HV-1600-SAC-CLL-EL15	49
62693	HV-2400-2SAC-CM-S/S	45	62748	H60CSK-B-S/S	55	62807	H2CP-2600-S/S	48	63224	HV-1800-SAC-CM-EL15	49
62694	HV-2400-2SAC-CL-S/S	45	62748	HCSTK-60-B-S/S	42	62807	H2CP-2600-S/S	54	63225	HV-1800-SAC-CL-EL15	49
62695	HV-2400-2SAC-CLL-S/S	45	62749	H73CSK-B	42	62808	H2CP-2800-S/S	48	63226	HV-1800-SAC-CLL-EL15	49
62696	HV-2600-2SAC-CM-S/S	45	62749	H73CSK-B	47	62808	H2CP-2800-S/S	54	63227	HV-600-SAC-CS-S/S-EL15	51
62697	HV-2600-2SAC-CL-S/S	45	62749	H73CSK-B	48	62809	H2CP-3000-S/S	48	63228	HV-600-SAC-CM-S/S-EL15	51
62698	HV-2600-2SAC-CLL-S/S	45	62749	H73CSK-B	53	62809	H2CP-3000-S/S	54	63229	HV-600-SAC-CL-S/S-EL15	51
62699	HV-2800-2SAC-CM-S/S	45	62749	H73CSK-B	54	62826	HTF212-S/S	15	63230	HV-800-SAC-CS-S/S-EL15	51
62700	HV-2800-2SAC-CL-S/S	45	62749	H73CSK-B	55	62827	HTF218-S/S	15	63231	HV-800-SAC-CM-S/S-EL15	51
62701	HV-2800-2SAC-CLL-S/S	45	62750	H73CSK-B-S/S	42	62828	HTF224-S/S	15	63232	HV-800-SAC-CL-S/S-EL15	51
62702	HV-3000-2SAC-CM-S/S	45	62750	H73CSK-B-S/S	47	62829	HTF230-S/S	15	63233	HV-1000-SAC-CS-S/S-EL15	51
62703	HV-3000-2SAC-CL-S/S	45	62750	H73CSK-B-S/S	48	62830	HTF236-S/S	15	63234	HV-1000-SAC-CM-S/S-EL15	51
62704	HV-3000-2SAC-CLL-S/S	45	62750	H73CSK-B-S/S	53	62831	HTF242-S/S	15	63235	HV-1000-SAC-CL-S/S-EL15	51
62705	H-CARK2-1200-CS-S/S	46	62750	H73CSK-B-S/S	54	62832	HTF248-S/S	15	63236	HV-1200-SAC-CS-S/S-EL15	51
62706	H-CARK2-1200-CM-S/S	46	62750	H73CSK-B-S/S	55	62833	HTF254-S/S	15	63237	HV-1200-SAC-CM-S/S-EL15	51
62707	H-CARK2-1200-CL-S/S	46	62751	HCP-600	47	62834	HTF260-S/S	15	63238	HV-1200-SAC-CL-S/S-EL15	51
62708	H-CARK2-1200-CLL-S/S	46	62751	HCP-600	53	62835	HTF272-S/S	15	63239	HV-1400-SAC-CS-S/S-EL15	51
62709	H-CARK2-1400-CS-S/S	46	62752	HCP-800	47	62836	EZP-LS212-S/S	10	63240	HV-1400-SAC-CM-S/S-EL15	51
62710	H-CARK2-1400-CM-S/S	46	62752	HCP-800	53	62837	EZP-LS218-S/S	10	63241	HV-1400-SAC-CL-S/S-EL15	51
62711	H-CARK2-1400-CL-S/S	46	62753	HCP-1000	47	62838	EZP-LS224-S/S	10	63242	HV-1600-SAC-CM-S/S-EL15	51
62712	H-CARK2-1400-CLL-S/S	46	62753	HCP-1000	53	62839	EZP-LS230-S/S	10	63243	HV-1600-SAC-CL-S/S-EL15	51
62713	H-CARK2-1600-CM-S/S	46	62754	HCP-1200	47	62840	EZP-LS236-S/S	10	63244	HV-1600-SAC-CLL-S/S-EL15	51
62714	H-CARK2-1600-CL-S/S	46	62754	HCP-1200	53	62841	EZP-LS242-S/S	10	63245	HV-1800-SAC-CM-S/S-EL15	51
62715	H-CARK2-1600-CLL-S/S	46	62755	HCP-1400	47	62842	EZP-LS248-S/S	10	63246	HV-1800-SAC-CL-S/S-EL15	51
62716	H-CARK2-1800-CM-S/S	46	62755	HCP-1400	53	62843	EZP-LS254-S/S	10	63247	HV-1800-SAC-CLL-S/S-EL15	51
62717	H-CARK2-1800-CL-S/S	46	62756	HCP-1800	47	62844	EZP-LS260-S/S	10	63421	HV-1200-2SAC-CS-EL15	49
62718	H-CARK2-1800-CLL-S/S	46	62756	HCP-1800	53	62845	EZP-LS212HT-S/S	10	63422	HV-1200-2SAC-CM-EL15	49
62719	H-CARK2-2000-CM-S/S	46	62757	HCP-600-S/S	47	62846	EZP-LS218HT-S/S	10	63423	HV-1200-2SAC-CL-EL15	49
62720	H-CARK2-2000-CL-S/S	46	62757	HCP-600-S/S	53	62847	EZP-LS224HT-S/S	10	63424	HV-1200-2SAC-CLL-EL15	49
62721	H-CARK2-2000-CLL-S/S	46	62758	HCP-800-S/S	47	62848	EZP-LS230HT-S/S	10	63425	HV-1400-2SAC-CS-EL15	49
62722	H-CARK2-2200-CM-S/S	46	62758	HCP-800-S/S	53	62849	EZP-LS236HT-S/S	10	63426	HV-1400-2SAC-CM-EL15	49
62723	H-CARK2-2200-CL-S/S	46	62759	HCP-1000-S/S	47	62850	EZP-LS242HT-S/S	10	63427	HV-1400-2SAC-CL-EL15	49
62724	H-CARK2-2200-CLL-S/S	46	62759	HCP-1000-S/S	53	62851	EZP-LS248HT-S/S	10	63428	HV-1400-2SAC-CLL-EL15	49
62725	H-CARK2-2400-CM-S/S	46	62760	HCP-1200-S/S	47	62852	EZP-LS254HT-S/S	10	63429	HV-1600-2SAC-CM-EL15	49
62726	H-CARK2-2400-CL-S/S	46	62760	HCP-1200-S/S	53	62853	EZP-LS260HT-S/S	10	63430	HV-1600-2SAC-CL-EL15	49
62727	H-CARK2-2400-CLL-S/S	46	62761	HCP-1400-S/S	47	63020	MSTHD-G	69	63431	HV-1600-2SAC-CLL-EL15	49
62728	H-CARK2-2600-CM-S/S	46	62761	HCP-1400-S/S	53	63024	CBD-ST-XL-S	150	63432	HV-1800-2SAC-CM-EL15	49
62729	H-CARK2-2600-CL-S/S	46	62762	HCP-1800-S/S	47	63072	ATVK-73	72	63433	HV-1800-2SAC-CL-EL15	49
62730	H-CARK2-2600-CLL-S/S	46	62762	HCP-1800-S/S	53	63072	ATVK-73	77	63434	HV-1800-2SAC-CLL-EL15	49
62731	H-CARK2-2800-CM-S/S	46	62763	H2CP-1200	48	63072	ATVK-73	97	63435	HV-2000-2SAC-CM-EL15	49
62732	H-CARK2-2800-CL-S/S	46	62763	H2CP-1200	54	63073	ATV-MOUNT	72	63436	HV-2000-2SAC-CL-EL15	49
62733	H-CARK2-2800-CLL-S/S	46	62764	H2CP-1400	48	63073	ATV-MOUNT	77	63437	HV-2000-2SAC-CLL-EL15	49
62734	H-CARK2-3000-CM-S/S	46	62764	H2CP-1400	54	63073	ATV-MOUNT	97	63438	HV-2200-2SAC-CM-EL15	49
62735	H-CARK2-3000-CL-S/S	46	62765	H2CP-1600	48	63079	H73BTK	47	63439	HV-2200-2SAC-CL-EL15	49
62736	H-CARK2-3000-CLL-S/S	46	62765	H2CP-1600	54	63079	H73BTK	48	63440	HV-2200-2SAC-CLL-EL15	49
62741	H60CSK-G	55	62766	H2CP-1800	48	63079	H73BTK	53	63441	HV-2400-2SAC-CM-EL15	49
62741	HCSTK-60-G	42	62766	H2CP-1800	54	63079	H73BTK	54	63442	HV-2400-2SAC-CL-EL15	49
62742	H60CSK-G-S/S	55	62767	H2CP-2000	48	63080	H73BTK-S/S	47	63443	HV-2400-2SAC-CLL-EL15	49
62742	HCSTK-60-G-S/S	42	62767	H2CP-2000	54	63080	H73BTK-S/S	48	63444	HV-2600-2SAC-CM-EL15	49
62743	H73CSK-G	42	62768	H2CP-2400	48	63080	H73BTK-S/S	53	63445	HV-2600-2SAC-CL-EL15	49

INDEX By Item Code

Item Code	Ordering Number	Page #	Item Code	Ordering Number	Page #	Item Code	Ordering Number	Page #	Item Code	Ordering Number	Page #
63446	HV-2600-2SAC-CLL-EL15	49	63594	H-CARK2-2800-CL-EL15	50	63641	H-CARK-1200-CM-EL15	50	63962	HV1600LL-PCST	40
63447	HV-2800-2SAC-CM-EL15	49	63595	H-CARK2-2800-CLL-EL15	50	63642	H-CARK-1200-CL-EL15	50	63963	HV1800M-PCST	40
63448	HV-2800-2SAC-CL-EL15	49	63596	H-CARK2-3000-CM-EL15	50	63643	H-CARK-1400-CS-EL15	50	63964	HV1800L-PCST	40
63449	HV-2800-2SAC-CLL-EL15	49	63597	H-CARK2-3000-CL-EL15	50	63644	H-CARK-1400-CM-EL15	50	63965	HV1800LL-PCST	40
63450	HV-3000-2SAC-CM-EL15	49	63598	H-CARK2-3000-CLL-EL15	50	63645	H-CARK-1400-CL-EL15	50	63966	HV2100M-PCST	40
63451	HV-3000-2SAC-CL-EL15	49	63599	H-CARK2-1200-CS-S/S-EL15	52	63646	H-CARK-1600-CS-EL15	50	63967	HV2100L-PCST	40
63452	HV-3000-2SAC-CLL-EL15	49	63600	H-CARK2-1200-CM-S/S-EL15	52	63647	H-CARK-1600-CM-EL15	50	63968	HV2100LL-PCST	40
63453	HV-1200-2SAC-CS-S/S-EL15	51	63601	H-CARK2-1200-CL-S/S-EL15	52	63648	H-CARK-1600-CL-EL15	50	63969	HV2400M-PCST	40
63454	HV-1200-2SAC-CM-S/S-EL15	51	63602	H-CARK2-1200-CLL-S/S-EL15	52	63649	H-CARK-1800-CS-EL15	50	63970	HV2400L-PCST	40
63455	HV-1200-2SAC-CL-S/S-EL15	51	63603	H-CARK2-1200-CLL-S/S-EL15	52	63650	H-CARK-1800-CM-EL15	50	63971	HV2400LL-PCST	40
63456	HV-1200-2SAC-CLL-S/S-EL15	51	63604	H-CARK2-1400-CS-S/S-EL15	52	63651	H-CARK-1800-CL-EL15	50	63972	HV2600M-PCST	40
63457	HV-1400-2SAC-CS-S/S-EL15	51	63605	H-CARK2-1400-CM-S/S-EL15	52	63652	H-CARK-600-CS-S/S-EL15	52	63973	HV2600L-PCST	40
63458	HV-1400-2SAC-CM-S/S-EL15	51	63606	H-CARK2-1400-CL-S/S-EL15	52	63653	H-CARK-600-CM-S/S-EL15	52	63974	HV2600LL-PCST	40
63459	HV-1400-2SAC-CL-S/S-EL15	51	63607	H-CARK2-1400-CLL-S/S-EL15	52	63654	H-CARK-600-CL-S/S-EL15	52	63975	HV3000M-PCST	40
63460	HV-1400-2SAC-CLL-S/S-EL15	51	63608	H-CARK2-1600-CM-S/S-EL15	52	63655	H-CARK-800-CS-S/S-EL15	52	63976	HV3000L-PCST	40
63461	HV-1600-2SAC-CM-S/S-EL15	51	63609	H-CARK2-1600-CL-S/S-EL15	52	63656	H-CARK-800-CM-S/S-EL15	52	63977	HV3000LL-PCST	40
63462	HV-1600-2SAC-CL-S/S-EL15	51	63610	H-CARK2-1600-CLL-S/S-EL15	52	63657	H-CARK-800-CL-S/S-EL15	52	63978	HV450SS-PCST-S/S	41
63463	HV-1600-2SAC-CLL-S/S-EL15	51	63611	H-CARK2-1800-CM-S/S-EL15	52	63658	H-CARK-1000-CS-S/S-EL15	52	63979	HV450S-PCST-S/S	41
63464	HV-1800-2SAC-CM-S/S-EL15	51	63612	H-CARK2-1800-CL-S/S-EL15	52	63659	H-CARK-1000-CM-S/S-EL15	52	63980	HV450M-PCST-S/S	41
63465	HV-1800-2SAC-CL-S/S-EL15	51	63613	H-CARK2-1800-CLL-S/S-EL15	52	63660	H-CARK-1000-CL-S/S-EL15	52	63981	HV600SS-PCST-S/S	41
63466	HV-1800-2SAC-CLL-S/S-EL15	51	63614	H-CARK2-2000-CM-S/S-EL15	52	63661	H-CARK-1200-CS-S/S-EL15	52	63982	HV600S-PCST-S/S	41
63467	HV-2000-2SAC-CM-S/S-EL15	51	63615	H-CARK2-2000-CL-S/S-EL15	52	63662	H-CARK-1200-CM-S/S-EL15	52	63983	HV600M-PCST-S/S	41
63468	HV-2000-2SAC-CL-S/S-EL15	51	63616	H-CARK2-2000-CLL-S/S-EL15	52	63663	H-CARK-1200-CL-S/S-EL15	52	63984	HV750SS-PCST-S/S	41
63469	HV-2000-2SAC-CLL-S/S-EL15	51	63617	H-CARK2-2200-CM-S/S-EL15	52	63664	H-CARK-1400-CS-S/S-EL15	52	63985	HV750S-PCST-S/S	41
63470	HV-2200-2SAC-CM-S/S-EL15	51	63618	H-CARK2-2200-CL-S/S-EL15	52	63665	H-CARK-1400-CM-S/S-EL15	52	63986	HV750M-PCST-S/S	41
63471	HV-2200-2SAC-CL-S/S-EL15	51	63619	H-CARK2-2200-CLL-S/S-EL15	52	63666	H-CARK-1400-CL-S/S-EL15	52	63987	HV900SS-PCST-S/S	41
63472	HV-2200-2SAC-CLL-S/S-EL15	51	63620	H-CARK2-2400-CM-S/S-EL15	52	63667	H-CARK-1600-CS-S/S-EL15	52	63988	HV900S-PCST-S/S	41
63473	HV-2400-2SAC-CM-S/S-EL15	51	63621	H-CARK2-2400-CL-S/S-EL15	52	63668	H-CARK-1600-CM-S/S-EL15	52	63989	HV900M-PCST-S/S	41
63474	HV-2400-2SAC-CL-S/S-EL15	51	63622	H-CARK2-2400-CLL-S/S-EL15	52	63669	H-CARK-1600-CL-S/S-EL15	52	63990	HV900L-PCST-S/S	41
63475	HV-2400-2SAC-CLL-S/S-EL15	51	63623	H-CARK2-2600-CM-S/S-EL15	52	63670	H-CARK-1800-CS-S/S-EL15	52	63991	HV1050SS-PCST-S/S	41
63476	HV-2600-2SAC-CM-S/S-EL15	51	63624	H-CARK2-2600-CL-S/S-EL15	52	63671	H-CARK-1800-CM-S/S-EL15	52	63992	HV1050S-PCST-S/S	41
63477	HV-2600-2SAC-CL-S/S-EL15	51	63625	H-CARK2-2600-CLL-S/S-EL15	52	63672	H-CARK-1800-CL-S/S-EL15	52	63993	HV1050M-PCST-S/S	41
63478	HV-2600-2SAC-CLL-S/S-EL15	51	63626	H-CARK2-2800-CM-S/S-EL15	52	63673	HDRP22	126	63994	HV1050L-PCST-S/S	41
63479	HV-2800-2SAC-CM-S/S-EL15	51	63627	H-CARK2-2800-CL-S/S-EL15	52	63674	HDRP17	126	63995	HV1200SS-PCST-S/S	41
63480	HV-2800-2SAC-CL-S/S-EL15	51	63628	H-CARK2-2800-CLL-S/S-EL15	52	63747	CBD-ST-XXL	150	63996	HV1200S-PCST-S/S	41
63481	HV-2800-2SAC-CLL-S/S-EL15	51	63629	H-CARK2-3000-CM-S/S-EL15	52	63748	CBD-ST-XXL-S/S	150	63997	HV1200M-PCST-S/S	41
63482	HV-3000-2SAC-CM-S/S-EL15	51	63630	H-CARK2-3000-CL-S/S-EL15	52	63749	CBD-ST-XXL-MF	150	63998	HV1200L-PCST-S/S	41
63483	HV-3000-2SAC-CL-S/S-EL15	51	63631	H-CARK-600-CS-EL15	50	63750	CBD-ST-XXL-MF-S/S	150	63999	HV1500M-PCST-S/S	41
63484	HV-3000-2SAC-CLL-S/S-EL15	51	63632	H-CARK-600-CL-EL15	50	63751	CBD-ST-XXL-FP	150	64000	HV1500L-PCST-S/S	41
63554	CBD-XXL-S/S	149	63633	H-CARK-600-CS-EL15	50	63752	CBD-ST-XXL-FR-B	150	64001	HV1500LL-PCST-S/S	41
63556	HVT8-EL15-S/S	54	63634	H-CARK-800-CS-EL15	50	63791	CBD-ST-XXL-S	150	64002	HV1600M-PCST-S/S	41
63567	H-CARK2-1200-CS-EL15	50	63635	H-CARK-800-CM-EL15	50	63861	HATDMK-S/S	55	64003	HV1600L-PCST-S/S	41
63568	H-CARK2-1200-CM-EL15	50	63636	H-CARK-800-CL-EL15	50	63862	HATDMK-S/S	55	64004	HV1600LL-PCST-S/S	41
63569	H-CARK2-1200-CL-EL15	50	63637	H-CARK-1000-CS-EL15	50	63936	HV450SS-PCST	40	64005	HVHD1800M-PCST-S/S	41
63570	H-CARK2-1200-CLL-EL15	50	63638	H-CARK-1000-CM-EL15	50	63937	HV450S-PCST	40	64006	HVHD1800L-PCST-S/S	41
63571	H-CARK2-1400-CS-EL15	50	63639	H-CARK-1000-CL-EL15	50	63938	HV450M-PCST	40	64007	HVHD1800LL-PCST-S/S	41
63572	H-CARK2-1400-CM-EL15	50	63640	H-CARK-1200-CS-EL15	50	63939	HV600SS-PCST	40	64008	HVHD2100M-PCST-S/S	41
63573	H-CARK2-1400-CL-EL15	50				63940	HV600S-PCST	40	64009	HVHD2100L-PCST-S/S	41
63574	H-CARK2-1400-CLL-EL15	50				63941	HV600M-PCST	40	64010	HVHD2100LL-PCST-S/S	41
63575	H-CARK2-1600-CM-EL15	50				63942	HV750SS-PCST	40	64011	HVHD2400M-PCST-S/S	41
63576	H-CARK2-1600-CL-EL15	50				63943	HV750S-PCST	40	64012	HVHD2400L-PCST-S/S	41
63577	H-CARK2-1600-CLL-EL15	50				63944	HV750M-PCST	40	64013	HVHD2400LL-PCST-S/S	41
63578	H-CARK2-1800-CM-EL15	50				63945	HV900SS-PCST	40	64014	HVHD2600M-PCST-S/S	41
63579	H-CARK2-1800-CL-EL15	50				63946	HV900S-PCST	40	64015	HVHD2600L-PCST-S/S	41
63580	H-CARK2-1800-CLL-EL15	50				63947	HV900M-PCST	40	64016	HVHD2600LL-PCST-S/S	41
63581	H-CARK2-2000-CM-EL15	50				63948	HV900L-PCST	40	64017	HVHD3000M-PCST-S/S	41
63582	H-CARK2-2000-CL-EL15	50				63950	HV1050S-PCST	40	64018	HVHD3000L-PCST-S/S	41
63583	H-CARK2-2000-CLL-EL15	50				63951	HV1050M-PCST	40	64019	HVHD3000LL-PCST-S/S	41
63584	H-CARK2-2200-CM-EL15	50				63952	HV1050L-PCST	40	64020	MHS-600-MST	70
63585	H-CARK2-2200-CL-EL15	50				63953	HV1200SS-PCST	40	64021	MHS-750-MST	70
63586	H-CARK2-2200-CLL-EL15	50				63954	HV1200S-PCST	40	64022	MHS-900-MST	70
63587	H-CARK2-2400-CM-EL15	50				63955	HV1200M-PCST	40	64023	MHS-1050-MST	70
63588	H-CARK2-2400-CL-EL15	50				63956	HV1200L-PCST	40	64024	MHS-1200-MST	70
63589	H-CARK2-2400-CLL-EL15	50				63957	HV1500M-PCST	40	64025	MHS-1350-MST	70
63590	H-CARK2-2600-CM-EL15	50				63958	HV1500L-PCST	40	64026	MHS-1500-MST	70
63591	H-CARK2-2600-CL-EL15	50				63959	HV1500LL-PCST	40	64027	MHS-1800-MST	70
63592	H-CARK2-2600-CLL-EL15	50				63960	HV1600M-PCST	40	64028	MHS-2100-MST	70
63593	H-CARK2-2800-CM-EL15	50				63961	HV1600L-PCST	40	64029	MHS-2400-MST	70

INDEX By Item Code

Item Code	Ordering Number	Page #	Item Code	Ordering Number	Page #	Item Code	Ordering Number	Page #	Item Code	Ordering Number	Page #
64030	MHS-600-MST-S/S	70	71056	FLSC-TP	166	73108	BP900	143	73489	HSA200	43
64031	MHS-750-MST-S/S	70	71057	FLSC-CP	166	73109	BP450-750-PL	144	73489	HSA200	47
64032	MHS-900-MST-S/S	70	71059	FLSC2000-MC	166	73110	BP1050	143	73489	HSA200	48
64033	MHS-1050-MST-S/S	70	71061	FLSC2000-CB	166	73111	BP800-1050-PL	144	73489	HSA200	49
64034	MHS-1200-MST-S/S	70	71140	FLSCM-CP	166	73112	BP1200	143	73489	HSA200	53
64035	MHS-1350-MST-S/S	70	71148	FLSCM2000	166	73113	BP1400	143	73489	HSA200	54
64036	MHS-1500-MST-S/S	70	72483	CBR-S	149	73114	BP1500	143	73494	HVC-S/S	42
64037	MHS-1800-MST-S/S	70	72484	CBR-L	149	73115	BP1600	143	73537	PS1800	122
64038	MHS-2100-MST-S/S	70	72485	CBR-L	149	73117	BP1800	143	73539	PS2000	122
64039	MHS-2400-MST-S/S	70	72486	CBR-XL	149	73118	BP1200-1400-PL	144	73541	PS750	122
64045	HV1050SS-PCST	40	73003	PP450	64	73119	BP1500-1600-PL	144	73542	PS900	122
64175	AIR HARK-S/S-73	55	73004	PV600	63	73121	BP1800-PL	144	73543	PS1050	122
64178	CBD-S-S/S	149	73005	PP600	64	73123	BP-MB	144	73544	PS1200	122
64310	CBD-ST-BB	150	73006	PV750	63	73125	BP-SC	144	73545	PS1500	122
64482	CBD-ST-XL-B	150	73007	PP750	64	73127	BP-LA	144	73546	PS1400	122
64620	CBD-ST-B	150	73008	PV900	63	73139	BP-UB	144	73582	PS600PL*	122
64621	CBD-ST-L-B	150	73009	PP900	64	73141	BP-TL	144	73583	PS750PL*	122
64622	CBD-ST-XXL-B	150	73010	PV1050	63	73147	BP1500-1600MF	144	73584	PS900PL*	122
64623	CBD-ST-M-P-S/S	150	73011	PP1050	64	73148	BP1800MF	144	73585	PS1050PL*	122
64624	CBD-ST-L-P-S/S	150	73012	PV1200	63	73152	BP450-750MF	144	73586	PS1200PL*	122
64625	CBD-ST-XL-P-S/S	150	73013	PP1200	64	73153	BP800-1050MF	144	73587	PS1400PL*	122
64626	CBD-ST-XXL-P-S/S	150	73014	PS600	122	73154	BP1200-1400MF	144	73588	PS1500PL*	122
64772	CBD-ST-M-P	150	73015	PP1400	64	73156	PSA150	64	73626	PHA	64
64773	CBD-ST-L-P	150	73016	PP1500	64	73156	PSA150	83	73626	PHA	83
64774	CBD-ST-XL-P	150	73019	HV450M	38	73156	PSA150 (V-Tip)	80	73628	RSA150	66
64775	CBD-ST-XXL-P	150	73020	PU150	64	73158	HV1500L	38	73628	RSA150	67
64776	CBD-ST-M-PSS	150	73024	PPS6	64	73160	PIHMK	62	73628	RSA150	69
64777	CBD-ST-L-PS	150	73025	P/RMK	61	73162	RBPCP	152	73628	RSA150	74
64778	CBD-ST-XL-PS	150	73026	HV450SS	38	73163	RBPRET	158	73628	RSA150	76
64779	CBD-ST-XXL-PS	150	73027	HP450	42	73173	HV600M	38	73628	RSA150	90
64780	CBD-ST-M-PS-S/S	150	73028	HV450S	38	73174	HV750M	38	73628	RSA150	96
64781	CBD-ST-L-PS-S/S	150	73029	HP600	42	73175	HV900M	38	73628	RSA150	103
64782	CBD-ST-XL-PS-S/S	150	73030	HV600S	38	73177	HV1500M	38	73628	RSA150 (V-Tip)	87
64783	CBD-ST-XXL-PS-S/S	150	73031	HP750	42	73178	HV900L	38	73628	RSA150 (V-Tip)	94
64784	CBD-ST-M-S	150	73032	HV750S	38	73179	HV1050L	38	73628	RSA150 (V-Tip)	101
64785	CBD-ST-L-S	150	73033	HP900	42	73180	HV1200L	38	73631	HVPT-S/S	38
64787	CBD-XXL	149	73034	HV900S	38	73215	HV1500LL	38	73631	HVPT-S/S	39
64924	MSR-S/S	165	73035	HP1050	42	73221	PSSS-N	122	73631	HVPT-S/S	40
64925	PMSMK-S/S	165	73036	HV1050M	38	73222	PSSS-H	122	73631	HVPT-S/S	41
64926	MAK-S/S	165	73037	HP1200	42	73235	CCKHDTS-S/S	64	73631	HVPT-S/S	42
64930	MSTLP	69	73038	HV1200M	38	73235	CCKHDTS-S/S	66	73631	HVPT-S/S	45
64930	MSTLP	69	73045	HV600SS	38	73235	CCKHDTS-S/S	74	73631	HVPT-S/S	47
64931	MSTAM-S/S	69	73047	HSA8SS	38	73301	BP800-HD-B	144	73631	HVPT-S/S	48
65660	FMS-600-EL15	67	73047	HSA8SS	40	73302	BP900-HD-B	144	73631	HVPT-S/S	51
65661	FMS-750-EL15	67	73048	HSA8S	38	73304	BP1050-HD-B	144	73631	HVPT-S/S	53
65662	FMS-900-EL15	67	73048	HSA8S	40	73306	BP1200-HD-B	144	73631	HVPT-S/S	54
65663	FMS-1050-EL15	67	73049	HSA8M	38	73307	BP1400-HD-B	144	73637	HV1600M	38
65664	FMS-1200-EL15	67	73049	HSA8M	40	73308	BP1500-HD-B	144	73638	HV1600L	38
65665	FMS-1350-EL15	67	73050	HPS8	42	73309	BP1600-HD-B	144	73639	HV1600LL	38
65666	FMS-1500-EL15	67	73053	HV750SS	38	73311	BP1800-HD-B	144	73738	BP-TB	144
65667	FMS-1800-EL15	67	73054	HMK	42	73433	PHSC-S/S	64	73739	HP1600	42
65668	FMS-2100-EL15	67	73055	HV900SS	38	73433	PHSC-S/S	85	73771	HSA8SS-S/S	39
65669	FMS-2400-EL15	67	73056	HV1050S	38	73433	PHSC-S/S	122	73771	HSA8SS-S/S	41
65670	FMS-600-EL15-S/S	67	73057	HV1050SS	38	73434	PSVA	122	73772	HSA8S-S/S	39
65671	FMS-750-EL15-S/S	67	73058	HV1200S	38	73435	PV450	63	73772	HSA8S-S/S	41
65672	FMS-900-EL15-S/S	67	73059	HV1200SS	38	73436	PV1400	63	73773	HSA8M-S/S	39
65673	FMS-1050-EL15-S/S	67	73063	HSA8L	38	73437	PV1500	63	73773	HSA8M-S/S	41
65674	FMS-1200-EL15-S/S	67	73063	HSA8L	40	73443	HXF1600M	36	73774	HSA8L-S/S	39
65675	FMS-1350-EL15-S/S	67	73064	HSA8LL	38	73444	HXF1600L	36	73774	HSA8L-S/S	41
65676	FMS-1500-EL15-S/S	67	73064	HSA8LL	40	73483	HSHD	42	73777	BP600-B	144
65677	FMS-1800-EL15-S/S	67	73066	HP1500	42	73483	HSHD	47	73778	BP750-B	144
65678	FMS-2100-EL15-S/S	67	73068	HBRK	42	73483	HSHD	48	73779	BP900-B	144
65679	FMS-2400-EL15-S/S	67	73069	HARK	42	73483	HSHD	53	73780	BP1050-B	144
65680	FMS-2100V	67	73069	HARK	110	73483	HSHD	54	73781	BP1200-B	144
65681	FMS-2400V	67	73102	BP450	143	73486	HSA	42	73782	BP1400-B	144
65682	FMS-2100V-S/S	67	73104	BP600	143	73489	HSA200	38	73784	BP1500-B	144
65683	FMS-2400V-S/S	67	73106	BP750	143	73489	HSA200	40	73784	BP1600-B	144
71053	FLSC2000	166	73107	BP800	143	73489	HSA200	42	73785	BP1800-B	144

INDEX By Item Code

Item Code	Ordering Number	Page #	Item Code	Ordering Number	Page #	Item Code	Ordering Number	Page #	Item Code	Ordering Number	Page #
73922	HBP-MB-TP	146	74553	PVHD2100	63	74690	HXF8M	36	75313	HV1200L-S/S	39
73922	HBP-MB-TP	148	74555	PVHD2400	63	74690	HXF8M	37	75314	HV1500M-S/S	39
73946	RBPFK-S	152	74556	PPHD2000	64	74691	HXF8L	36	75315	HV1500L-S/S	39
73947	RBPFK-M	152	74557	PPHD2400	64	74691	HXF8L	37	75316	HV1500LL-S/S	39
73948	RBPFK-L	152	74558	PSR-S	151	74773	PSSS	64	75317	HV1600M-S/S	39
73949	RBPFK-XL	152	74559	PSR-M	151	74775	STJM	42	75318	HV1600L-S/S	39
74033	HSA8LL-S/S	39	74560	PSR-L	151	74775	STJM	42	75319	HV1600LL-S/S	39
74033	HSA8LL-S/S	41	74561	PSR-XL	151	74775	STJM	110	75323	PV450-S/S	63
74049	PS1800PL*	122	74562	RBPSR-S	152	74914	MSR	163	75324	PV600-S/S	63
74050	PS2000 PL*	122	74563	RBPSR-M	152	74914	MSR	165	75325	PV750-S/S	63
74053	PSN11010	122	74564	RBPSR-L	152	74916	PMSMK	165	75326	PV900-S/S	63
74055	BP450-B	144	74565	RBPSR-XL	152	74918	MAK	165	75327	PV1050-S/S	63
74057	BP800-B	144	74582	HDMRK	42	74919	MAKHD	165	75328	PV1200-S/S	63
74100	HW-BC	126	74582	HDMRK	42	74919	MAKHD	165	75329	PV1400-S/S	63
74141	HTTS	126	74591	HVHD3000M	38	74921	MORK	165	75330	PV1500-S/S	63
74307	HXF8SS	36	74592	HVHD3000L	38	74921	MORK	165	75341	RV450-S/S	65
74307	HXF8SS	37	74593	HVHD3000LL	38	74923	MCRK	165	75342	RV600-S/S	65
74327	RBPMBK	152	74597	PPHD1800	64	74923	MCRK	165	75343	RV750-S/S	65
74417	STJK	42	74598	PVHD1800	63	74925	MCB	165	75344	RV900-S/S	65
74417	STJK	42	74601	HPHD1800	42	74925	MCB	165	75345	RV1050-S/S	65
74417	STJK-S/S	110	74602	HVHD1800M	38	74927	MCSK	165	75346	RV1200-S/S	65
74417	STJK-S/S	111	74604	RP450	66	74927	MCSK	165	75347	RV1400-S/S	65
74419	STTS	42	74605	RP600	66	74928	MCSKHD	165	75348	RV1500-S/S	65
74419	STTS	110	74606	RP750	66	74928	MCSKHD	165	75373	HP450-S/S	42
74420	UTS	42	74607	RP900	66	74930	MCS	165	75374	HP600-S/S	42
74448	UFB18	112	74608	RP1050	66	74930	MCS	165	75375	HP750-S/S	42
74449	UFB24	112	74609	RP1200	66	74931	MCSHD	165	75376	HP900-S/S	42
74450	UFB30	112	74610	RP1400	66	74931	MCSHD	165	75377	HP1050-S/S	42
74451	UFB36	112	74611	RP1500	66	74941	SRBK	126	75378	HP1200-S/S	42
74452	UFB42	112	74613	RPHD1800	66	75266	HXF450S-S/S	37	75379	HP1500-S/S	42
74453	UFB48	112	74614	RPHD2000	66	75267	HXF450M-S/S	37	75380	HP1600-S/S	42
74454	UFB54	112	74615	RPHD2400	66	75268	HXF600S-S/S	37	75382	PP450-S/S	64
74455	UFB60	112	74633	RV450	65	75269	HXF600M-S/S	37	75383	PP600-S/S	64
74456	UFB72	112	74634	RV600	65	75270	HXF750S-S/S	37	75384	PP750-S/S	64
74460	UFB84	112	74635	RV750	65	75271	HXF750M-S/S	37	75385	PP900-S/S	64
74477	HVHD1800L	38	74636	RV900	65	75272	HXF900S-S/S	37	75386	PP1050-S/S	64
74478	HVHD1800LL	38	74637	RV1050	65	75273	HXF900M-S/S	37	75387	PP1200-S/S	64
74490	HBP-SC-TP	146	74638	RV1200	65	75274	HXF900L-S/S	37	75388	PP1400-S/S	64
74490	HDCK	42	74639	RV1400	65	75275	HXF1050S-S/S	37	75389	PP1500-S/S	64
74502	HDTs	110	74640	RV1500	65	75276	HXF1050M-S/S	37	75400	RP450-S/S	66
74504	STKD	42	74642	RVHD1800	65	75277	HXF1050L-S/S	37	75401	RP600-S/S	66
74506	STCK	42	74643	RVHD2100	65	75278	HXF1200S-S/S	37	75402	RP750-S/S	66
74535	CT6	64	74644	RVHD2400	65	75279	HXF1200M-S/S	37	75403	RP900-S/S	66
74535	CT6	66	74659	HXF450S	36	75280	HXF1200L-S/S	37	75404	RP1050-S/S	66
74535	CT6	67	74660	HXF450M	36	75281	HXF1500M-S/S	37	75405	RP1200-S/S	66
74535	CT6	69	74661	HXF600S	36	75282	HXF1500L-S/S	37	75406	RP1400-S/S	66
74535	CT6	74	74662	HXF600M	36	75283	HXF1600M-S/S	37	75407	RP1500-S/S	66
74535	CT6	76	74663	HXF750S	36	75284	HXF1600L-S/S	37	75419	HVT8-S/S	39
74535	CT6	83	74664	HXF750M	36	75293	HV450SS-S/S	39	75419	HVT8-S/S	41
74535	CT6	85	74665	HXF900S	36	75294	HV450S-S/S	39	75419	HVT8-S/S	42
74535	CT6	90	74666	HXF900M	36	75295	HV450M-S/S	39	75419	HVT8-S/S	45
74535	CT6	92	74667	HXF900L	36	75296	HV600SS-S/S	39	75419	HVT8-S/S	47
74535	CT6	96	74668	HXF1050S	36	75297	HV600S-S/S	39	75419	HVT8-S/S	48
74535	CT6	99	74669	HXF1050M	36	75298	HV600M-S/S	39	75419	HVT8-S/S	51
74535	CT6 (C-Tip)	80	74670	HXF1050L	36	75299	HV750SS-S/S	39	75419	HVT8-S/S	53
74535	CT6 (C-Tip)	87	74671	HXF1200S	36	75300	HV750S-S/S	39	75419	HVT8-S/S	54
74535	CT6 (C-Tip)	94	74672	HXF1200M	36	75301	HV750M-S/S	39	75420	PVT6-S/S	64
74539	HVHD2100M	38	74673	HXF1200L	36	75302	HV900SS-S/S	39	75420	PVT6-S/S	85
74540	HVHD2100L	38	74677	HXF1500M	36	75303	HV900S-S/S	39	75420	PVT6-S/S	122
74541	HVHD2100LL	38	74678	HXF1500L	36	75304	HV900M-S/S	39	75422	HBRK-S/S	42
74544	HVHD2400M	38	74681	HXFHD1800M	36	75305	HV900L-S/S	39	75422	HBRK-S/S-60	55
74545	HVHD2400L	38	74682	HXFHD1800L	36	75306	HV1050SS-S/S	39	75423	HARK-S/S	42
74546	HVHD2400LL	38	74683	HXFHD2100M	36	75307	HV1050S-S/S	39	75424	HMK-S/S	42
74547	HPHD2000	42	74684	HXFHD2100L	36	75308	HV1050M-S/S	39	75425	STCK-S/S	42
74548	HPHD2400	42	74685	HXFHD2400M	36	75309	HV1050L-S/S	39	75426	STJM-S/S	42
74549	HBRKX	42	74686	HXFHD2400L	36	75310	HV1200SS-S/S	39	75426	STJM-S/S	42
74550	HDARK	42	74689	HXF8S	36	75311	HV1200S-S/S	39	75427	STKD-S/S	42
74551	HDMK	42	74689	HXF8S	37	75312	HV1200M-S/S	39	75452	PVHD2000	63

INDEX By Item Code

Item Code	Ordering Number	Page #	Item Code	Ordering Number	Page #	Item Code	Ordering Number	Page #	Item Code	Ordering Number	Page #
75463	RVHD2000	65	75619	EZP1P12	17	75896	PSTA	32	76074	QMT-P	25
75507	PCB	61	75619	EZP1P12	21	75897	PTPK	32	76075	QMT-W	25
75510	PHDCB	62	75620	EZP1P18	17	75898	PSTS-W	25	76096	QMTPAK	25
75513	PAB	61	75620	EZP1P18	21	75898	PSTS-W	32	76097	QMTBK-P	25
75513	PAB	62	75621	EZP1P24	17	75898	PSTS-W	35	76097	QMTBK-P	27
75513	PAB	64	75621	EZP1P24	21	75898	PSTS-W	110	76098	QMTBK-W	25
75513	PAB	66	75622	EZP1P30	17	75899	PSTS-S	32	76098	QMTBK-W	27
75513	PAB	74	75622	EZP1P30	21	75899	PSTS-S	35	76098	QMTBK-W	32
75513	PAB	83	75623	EZP1P36	17	75899	PSTS-S	55	76098	QMTBK-W	35
75513	PAB	90	75623	EZP1P36	21	75904	AWT	26	76099	QMTPSBK	25
75513	PAB	103	75624	EZP1P42	17	75904	AWT	32	76205	RVT6-S/S	66
75513	PAB	117	75624	EZP1P42	21	75905	AWTB	26	76205	RVT6-S/S	67
75515	PAB-S/S	64	75625	EZP1P48	17	75905	AWTB	32	76205	RVT6-S/S	69
75515	PAB-S/S	66	75625	EZP1P48	21	75906	AWTMB	26	76205	RVT6-S/S	74
75515	PAB-S/S	74	75626	EZP1P54	17	75906	AWTMB	32	76205	RVT6-S/S	76
75515	PAB-S/S	85	75626	EZP1P54	21	75907	AWTA	26	76205	RVT6-S/S	92
75515	PAB-S/S	92	75627	EZP1P60	17	75907	AWTA	32	76205	RVT6-S/S	99
75515	PAB-S/S	105	75627	EZP1P60	21	75908	AWTCB	26	76205	RVT6-S/S	105
75516	PMBL	83	75629	CRB16	19	75908	AWTCB	32	76245	HDMRK-S/S	42
75516	PMBL	90	75630	CRB22	19	75909	AWTHK	26	76245	HDMRK-S/S	42
75516	PMBL	103	75631	CRB28	19	75909	AWTHK	32	76246	HBRK-S/S-73	55
75516	PMBL	117	75632	CRB34	19	75929	MHCP-24S	30	76246	HBRKX-S/S	42
75516	PMBL (left)	61	75633	CRB40	19	75930	MHCP-30S	30	76247	HDARK-S/S	42
75516	PMBL (left)	62	75634	CRB46	19	75931	MHCP-36S	30	76248	HDMK-S/S	42
75516	PMBL (left)	64	75635	CRB52	19	75932	MHCP-42S	30	76249	RSA	66
75516	PMBL (left)	66	75636	CRB58	19	75933	MHCP-48S	30	76249	RSA	90
75516	PMBL (left)	74	75637	EZP1MPK	17	75934	MHCP-54S	30	76250	RC-S/S	66
75518	PMBL-S/S	72	75641	EZP1PL	17	75935	MHCP-60S	30	76250	RC-S/S	92
75518	PMBL-S/S	77	75641	EZP1PL	21	75936	MHCP-72S	30	76318	CBD-XL-S/S	149
75518	PMBL-S/S	85	75642	EZP1BP	17	75937	MHCP-24A	30	76319	URCB88/2200	112
75518	PMBL-S/S	92	75642	EZP1BP	21	75938	MHCP-30A	30	76337	BP450-S/S	143
75518	PMBL-S/S	97	75771	EZP1-272	15	75939	MHCP-36A	30	76338	BP600-S/S	143
75518	PMBL-S/S	105	75772	EZP1P72	17	75940	MHCP-42A	30	76339	BP750-S/S	143
75518	PMBL-S/S (left)	64	75772	EZP1P72	21	75941	MHCP-48A	30	76340	BP800-S/S	143
75518	PMBL-S/S (left)	66	75773	CRB70	19	75942	MHCP-54A	30	76341	BP900-S/S	143
75518	PMBL-S/S (left)	74	75775	CRB64	19	75943	MHCP-60A	30	76342	BP1050-S/S	143
75519	PMBL (right)	64	75811	MSPMPK	25	75944	MHCP-72A	30	76343	BP1200-S/S	143
75519	PMBL (right)	66	75817	RMC1-CB	167	75961	MHP-CP600	32	76344	BP1400-S/S	143
75519	PMBL (right)	74	75830	MMBK	127	75962	MHP-CP750	32	76345	BP1500-S/S	143
75519	PMBR	83	75832	RMC1-PP	167	75963	MHP-CP900	32	76346	BP1600-S/S	143
75519	PMBR	90	75843	STS-S	62	75964	MHP-CP1050	32	76347	BP1800-S/S	143
75519	PMBR	103	75843	STS-S	69	75965	MHP-CP1200	32	76375	AWT-1S	26
75519	PMBR	117	75843	STS-S	76	75966	MHP-CP1400	32	76375	AWT-1S	32
75519	PMBR (right)	61	75843	STS-S	97	75967	MHP-CP1500	32	76392	MHP-EP	25
75519	PMBR (right)	62	75844	STS-B	55	75968	MHP-CP1800	32	76392	MHP-EP	32
75521	PMBL-S/S (right)	64	75844	STS-B	55	75978	SSRB	32	76392	MHP-EP	48
75521	PMBL-S/S (right)	66	75844	STS-B	62	75978	SSRB	35	76392	MHP-EP	54
75521	PMBL-S/S (right)	74	75844	STS-B	69	75979	HXF2-SS	36	76392	MHP-EP	82
75521	PMBR-S/S	72	75844	STS-B	76	75979	HXF2-SS	37	76392	MHP-EP	89
75521	PMBR-S/S	77	75844	STS-B	97	75980	HXF2-S	36	76392	MHP-EP	96
75521	PMBR-S/S	85	75845	QMTS-P	17	75980	HXF2-S	37	76392	MHP-EP	103
75521	PMBR-S/S	92	75845	QMTS-P	25	75981	HXF2-M	36	76393	MHCP-CH	32
75521	PMBR-S/S	97	75845	QMTS-P	110	75981	HXF2-M	37	76394	MHCP-BS	32
75521	PMBR-S/S	105	75846	STS-W	69	75982	HXF2-L	36	76403	EST-P	17
75531	MFASK	165	75846	STS-W	76	75982	HXF2-L	37	76404	EST-S	17
75531	MFASK	165	75846	STS-W	97	76024	MAPEK	127	76405	EST-B	17
75565	HSA8SSS	39	75847	STAK	76	76025	MCBK	165	76406	ESTAK	17
75565	HSA8SSS	41	75847	STAK	76	76025	MCBK	165	76406	ESTAK	110
75585	STTS-S/S	111	75847	STAK	97	76026	MCBKHD	165	76406	ESTAK-EST	55
75586	HDTs-S/S	111	75847	STAK	99	76026	MCBKHD	165	76407	ESPSBK	17
75611	EZP1-218	15	75892	STAKHD	76	76027	HSA200-EL15	49	76408	ESPBK	17
75612	EZP1-224	15	75892	STAKHD	76	76027	HSA200-EL15	53	76409	ESPRK	17
75613	EZP1-230	15	75892	STAKHD	97	76027	HSA200-EL15	54	76410	ESBK-PS	17
75614	EZP1-236	15	75892	STAKHD	99	76069	AWTNCB	26	76411	ESBK-B	17
75615	EZP1-242	15	75893	PST-W	32	76069	AWTNCB	32	76412	ESS-S	17
75616	EZP1-248	15	75894	PST-S	32	76071	SSTSMB	127	76412	ESS-S	110
75617	EZP1-254	15	75895	PMB	32	76072	SSTLMB	127	76413	ESS-B	17
75618	EZP1-260	15	75896	PSTA	25	76073	SSTOTA	127	76415	RMC1-BPP	167

INDEX By Item Code

Item Code	Ordering Number	Page #	Item Code	Ordering Number	Page #	Item Code	Ordering Number	Page #	Item Code	Ordering Number	Page #
76442	CBD-S	149	76493	TRB66	27	76736	URVB18/450	109	76808	MMPCP84	25
76443	CBD-M	149	76494	TRB72	23	76736	URVB18/450	109	76811	MHP-CP2100	32
76444	CBD-L	149	76494	TRB72	25	76736	URVB18/450	112	76812	MHCP-2BC84	32
76445	CBD-XL	149	76494	TRB72	27	76737	URVB24/600	108	76816	DRXL-24-420	138
76446	DBK-S	149	76537	MMPK	127	76737	URVB24/600	108	76817	DRXL-30-420	138
76447	DBK-M	149	76540	QMTBK-G	25	76737	URVB24/600	109	76818	DRXL-36-420	138
76448	DBK-L	149	76540	QMTBK-G	27	76737	URVB24/600	109	76819	DRXL-42-420	138
76449	DBK-XL	149	76558	RMC-FS	167	76737	URVB24/600	112	76820	DRXL-48-420	138
76450	MMP-624	23	76559	RMC2-AP	167	76738	URVB30/750	108	76821	DRXL-54-420	138
76451	MMP-630	23	76593	CRB-HT10	19	76738	URVB30/750	108	76822	DRXL-60-420	138
76452	MMP-636	23	76594	CRB-HT16	19	76738	URVB30/750	109	76823	DRXL-72-420	138
76453	MMP-642	23	76595	CRB-HT22	19	76738	URVB30/750	109	76824	DRXL-24-520	138
76454	MMP-648	23	76596	CRB-HT28	19	76738	URVB30/750	112	76825	DRXL-30-520	138
76455	MMP-654	23	76597	CRB-HT34	19	76739	URVB36/900	108	76826	DRXL-36-520	138
76456	MMP-660	23	76598	CRB-HT40	19	76739	URVB36/900	108	76827	DRXL-42-520	138
76457	MMP-672	23	76599	CRB-HT46	19	76739	URVB36/900	109	76828	DRXL-48-520	138
76458	MMPCP24	25	76600	CRB-HT52	19	76739	URVB36/900	109	76829	DRXL-54-520	138
76459	MMPCP30	25	76601	CRB-HT58	19	76739	URVB36/900	112	76830	DRXL-60-520	138
76460	MMPCP36	25	76602	CRB-HT64	19	76740	URVB42/1050	108	76831	DRXL-72-520	138
76461	MMPCP42	25	76603	CRB-HT70	19	76740	URVB42/1050	108	76832	DRXL-24-435	138
76462	MMPCP48	25	76636	SSTBK-W	76	76740	URVB42/1050	109	76833	DRXL-30-435	138
76463	MMPCP54	25	76636	SSTBK-W	76	76740	URVB42/1050	109	76834	DRXL-36-435	138
76464	MMPCP60	25	76636	SSTBK-W	97	76740	URVB42/1050	112	76835	DRXL-42-435	138
76465	MMPCP72	25	76636	SSTBK-W	99	76741	URVB48/1200	108	76836	DRXL-48-435	138
76466	MMPBPK	25	76637	SSTBK-B	76	76741	URVB48/1200	108	76837	DRXL-54-435	138
76467	HSHD-S/S	42	76637	SSTBK-B	76	76741	URVB48/1200	109	76838	DRXL-60-435	138
76467	HSHD-S/S	47	76637	SSTBK-B	97	76741	URVB48/1200	109	76839	DRXL-72-435	138
76467	HSHD-S/S	48	76637	SSTBK-B	99	76741	URVB48/1200	112	76840	DRXL-24-535	138
76467	HSHD-S/S	53	76638	MHCP-2BC24	32	76742	URVB54/1350	108	76841	DRXL-30-535	138
76467	HSHD-S/S	54	76639	MHCP-2BC30	32	76742	URVB54/1350	108	76842	DRXL-36-535	138
76472	FLEL-M	169	76640	MHCP-2BC36	32	76742	URVB54/1350	109	76843	DRXL-42-535	138
76473	FLEL-L	169	76641	MHCP-2BC42	32	76742	URVB54/1350	109	76844	DRXL-48-535	138
76474	FLELP	169	76642	MHCP-2BC48	32	76742	URVB54/1350	112	76845	DRXL-54-535	138
76476	FLTW-M	169	76643	MHCP-2BC54	32	76743	URVB60/1500	108	76846	DRXL-60-535	138
76477	FLTW-L	169	76644	MHCP-2BC60	32	76743	URVB60/1500	108	76847	DRXL-72-535	138
76478	FLRP	169	76645	MHCP-2BC72	32	76743	URVB60/1500	109	76848	DRXM-24-420	139
76479	FLCP	169	76658	HTF212	15	76743	URVB60/1500	109	76849	DRXM-30-420	139
76481	FLRLB-L	169	76659	HTF218	15	76743	URVB60/1500	112	76850	DRXM-36-420	139
76482	FLRLB-M	169	76660	HTF224	15	76744	URVB72/1800	108	76851	DRXM-42-420	139
76483	QMT-G	25	76661	HTF230	15	76744	URVB72/1800	108	76852	DRXM-48-420	139
76484	QMT-G	110	76662	HTF236	15	76744	URVB72/1800	109	76853	DRXM-54-420	139
76484	QMTS-G	25	76663	HTF242	15	76744	URVB72/1800	109	76854	DRXM-60-420	139
76485	TRB18	23	76664	HTF248	15	76744	URVB72/1800	112	76855	DRXM-72-420	139
76485	TRB18	25	76665	HTF254	15	76745	URVB84/2100	108	76856	DRXM-24-520	139
76485	TRB18	27	76666	HTF260	15	76745	URVB84/2100	108	76857	DRXM-30-520	139
76486	TRB24	23	76667	HTF272	15	76745	URVB84/2100	109	76858	DRXM-36-520	139
76486	TRB24	25	76668	CBC18	117	76745	URVB84/2100	109	76859	DRXM-42-520	139
76486	TRB24	27	76669	CBC24	117	76745	URVB84/2100	112	76860	DRXM-48-520	139
76487	TRB30	23	76670	CBC30	117	76748	URCB18/450	112	76861	DRXM-54-520	139
76487	TRB30	25	76671	CBC36	117	76749	URCB24/600	112	76862	DRXM-60-520	139
76487	TRB30	27	76672	CBC42	117	76750	URCB30/750	112	76863	DRXM-72-520	139
76488	TRB36	23	76673	CBC48	117	76751	URCB36/900	112	76864	DRXM-24-435	139
76488	TRB36	25	76674	CBC54	117	76752	URCB42/1050	112	76865	DRXM-30-435	139
76488	TRB36	27	76675	CBC60	117	76753	URCB48/1200	112	76866	DRXM-36-435	139
76489	TRB42	23	76684	CDS18	117	76754	URCB54/1350	112	76867	DRXM-42-435	139
76489	TRB42	25	76685	CDS24	117	76755	URCB60/1500	112	76868	DRXM-48-435	139
76489	TRB42	27	76686	CDS30	117	76756	URCB72/1800	112	76869	DRXM-54-435	139
76490	TRB48	23	76687	CDS36	117	76757	URCB84/2100	112	76870	DRXM-60-435	139
76490	TRB48	25	76688	CDS42	117	76787	UHPB	110	76871	DRXM-72-435	139
76490	TRB48	27	76689	CDS48	117	76787	UHPB	111	76872	DRXM-24-535	139
76491	TRB54	23	76690	CDS54	117	76788	ABU	110	76873	DRXM-30-535	139
76491	TRB54	25	76691	CDS60	117	76788	ABU	110	76874	DRXM-36-535	139
76491	TRB54	27	76692	CPB	117	76788	ABU	111	76875	DRXM-42-535	139
76492	TRB60	23	76697	TRB78	23	76788	ABU	111	76876	DRXM-48-535	139
76492	TRB60	25	76697	TRB78	25	76790	USPK	110	76877	DRXM-54-535	139
76492	TRB60	27	76697	TRB78	27	76798	MMP-684	23	76878	DRXM-60-535	139
76493	TRB66	23	76736	URVB18/450	108	76800	MHCP-84S	30	76879	DRXM-72-535	139
76493	TRB66	25	76736	URVB18/450	108	76801	MHCP-84A	30	76880	DRXH-24-420	140

INDEX By Item Code

Item Code	Ordering Number	Page #	Item Code	Ordering Number	Page #	Item Code	Ordering Number	Page #	Item Code	Ordering Number	Page #
76881	DRXH-30-420	140	76934	IBS-DH5	141	77118	LS-SS	12	77309	UTV2100	108
76882	DRXH-36-420	140	76935	ISABK	141	77118	LS-SS	13	77310	UTV2200	108
76883	DRXH-42-420	140	76936	IMK	138	77120	LST-TAK	12	77314	URVB56/1400	108
76884	DRXH-48-420	140	76936	IMK	139	77120	LST-TAK	13	77314	URVB56/1400	108
76885	DRXH-54-420	140	76936	IMK	140	77121	LST-P	12	77314	URVB56/1400	109
76886	DRXH-60-420	140	76937	IEA42-60D	141	77122	LST-W	12	77314	URVB56/1400	109
76887	DRXH-72-420	140	76938	IEA72-96D	141	77123	LST-S	12	77314	URVB56/1400	112
76888	DRXH-24-520	140	76939	HW-IMPB	142	77124	LST-B-S/S	13	77315	URVB64/1600	108
76889	DRXH-30-520	140	76950	OIBBK	142	77125	LST-W-S/S	13	77315	URVB64/1600	108
76890	DRXH-36-520	140	76965	IB4-1U	142	77126	LST-W-S/S-2	13	77315	URVB64/1600	109
76891	DRXH-42-520	140	76966	IB5-1U	142	77127	EZP-LS212	10	77315	URVB64/1600	109
76892	DRXH-48-520	140	76979	FL-M	169	77128	EZP-LS218	10	77315	URVB64/1600	112
76893	DRXH-54-520	140	76980	FL-L	169	77129	EZP-LS224	10	77316	URVB88/2200	108
76894	DRXH-60-520	140	76983	FL-XL	169	77130	EZP-LS230	10	77316	URVB88/2200	108
76895	DRXH-72-520	140	76984	FLVRL-XL	169	77131	EZP-LS236	10	77316	URVB88/2200	109
76896	DRXH-24-435	140	76985	FLTW-XL	169	77132	EZP-LS242	10	77316	URVB88/2200	109
76897	DRXH-30-435	140	76986	FLELK-XL	169	77133	EZP-LS248	10	77316	URVB88/2200	112
76898	DRXH-36-435	140	77031	CSTAK	97	77134	EZP-LS254	10	77317	URCB56/1400	112
76899	DRXH-42-435	140	77031	CSTAK	99	77135	EZP-LS260	10	77318	URCB64/1600	112
76900	DRXH-48-435	140	77037	CSTBK	97	77144	CLSFG-212	10	77320	URVB80/2000	108
76901	DRXH-54-435	140	77037	CSTBK	99	77145	CLSFG-218	10	77320	URVB80/2000	108
76902	DRXH-60-435	140	77047	TRB84	25	77146	CLSFG-224	10	77320	URVB80/2000	109
76903	DRXH-72-435	140	77047	TRB84	27	77147	CLSFG-230	10	77320	URVB80/2000	109
76904	DRXH-24-535	140	77048	TRB90	25	77148	CLSFG-236	10	77320	URVB80/2000	112
76905	DRXH-30-535	140	77048	TRB90	27	77149	CLSFG-242	10	77321	URCB80/2000	112
76906	DRXH-36-535	140	77052	SACSK	97	77150	CLSFG-248	10	77324	MMKU	110
76907	DRXH-42-535	140	77052	SACSK	99	77151	CLSFG-254	10	77327	MMKUHD	110
76908	DRXH-48-535	140	77065	SACSRC	97	77152	CLSFG-260	10	77329	HDARK	110
76909	DRXH-54-535	140	77065	SACSRC	99	77259	UTV450J-S/S	109	77331	HDARK-S/S	111
76910	DRXH-60-535	140	77070	LSP12	12	77260	UTV600J-S/S	109	77332	STJM-S/S	111
76911	DRXH-72-535	140	77071	LSP18	12	77261	UTV750J-S/S	109	77339	USP18/450-S/S	111
76912	DRXD-42-520	141	77072	LSP24	12	77262	UTV900J-S/S	109	77340	USP24/600-S/S	111
76913	DRXD-48-520	141	77073	LSP30	12	77263	UTV1050J-S/S	109	77341	USP30/750-S/S	111
76914	DRXD-54-520	141	77074	LSP36	12	77264	UTV1200J-S/S	109	77342	USP36/900-S/S	111
76915	DRXD-60-520	141	77075	LSP42	12	77265	UTV1350J-S/S	109	77343	USP42/1050-S/S	111
76916	DRXD-72-520	141	77076	LSP48	12	77266	UTV1400J-S/S	109	77344	USP48/1200-S/S	111
76917	DRXD-84-520	141	77077	LSP54	12	77267	UTV1500J-S/S	109	77345	USP54/1350-S/S	111
76918	DRXD-96-520	141	77078	LSP60	12	77268	UTV1600J-S/S	109	77346	USP56/1400-S/S	111
76919	DRXD-42-535	141	77079	LSP12-S/S	13	77269	UTV1800J-S/S	109	77347	USP60/1500-S/S	111
76920	DRXD-48-535	141	77080	LSP18-S/S	13	77270	UTV2000J-S/S	109	77348	USP64/1600-S/S	111
76921	DRXD-54-535	141	77081	LSP24-S/S	13	77271	UTV2100J-S/S	109	77349	USP72/1800-S/S	111
76922	DRXD-60-535	141	77082	LSP30-S/S	13	77272	UTV2200J-S/S	109	77350	USP80/2000-S/S	111
76923	DRXD-72-535	141	77083	LSP36-S/S	13	77283	UTV450-J	109	77351	USP84/2100-S/S	111
76924	DRXD-84-535	141	77084	LSP42-S/S	13	77284	UTV600-J	109	77352	USP88/2200-S/S	111
76925	DRXD-96-535	141	77085	LSP48-S/S	13	77285	UTV750-J	109	77357	MMKU-SS	111
76926	IB4	132	77086	LSP54-S/S	13	77286	UTV900-J	109	77358	MMKUHD-SS	111
76926	IB4	134	77087	LSP60-S/S	13	77287	UTV1050-J	109	77364	HARK-S/S	111
76926	IB4	136	77088	CRB-LS10	14	77288	UTV1200-J	109	77365	LS-SP	12
76926	IB4	138	77089	CRB-LS16	14	77289	UTV1350-J	109	77366	LSTMPK	12
76926	IB4	139	77090	CRB-LS22	14	77290	UTV1400-J	109	77367	LSTPB-RK	12
76926	IB4	140	77091	CRB-LS28	14	77291	UTV1500-J	109	77367	LSTPB-RK	13
76927	IB5	132	77092	CRB-LS34	14	77292	UTV1600-J	109	77384	EZPTBT	21
76927	IB5	134	77093	CRB-LS40	14	77293	UTV1800-J	109	77385	EZPTBTHD	21
76927	IB5	136	77094	CRB-LS46	14	77294	UTV2000-J	109	77387	SPG-CVR-A	22
76927	IB5	138	77095	CRB-LS52	14	77295	UTV2100-J	109	77387	SPG-CVR-A	79
76927	IB5	139	77096	CRB-LS58	14	77296	UTV2200-J	109	77387	SPG-CVR-A	107
76927	IB5	140	77097	CRB-LS10W	14	77297	UTV450	108	77388	SPG-CVR-B	22
76927	IB5	141	77098	CRB-LS16W	14	77298	UTV600	108	77388	SPG-CVR-B	79
76928	IBBK	138	77099	CRB-LS22W	14	77299	UTV750	108	77388	SPG-CVR-B	107
76928	IBBK	139	77100	CRB-LS28W	14	77300	UTV900	108	77389	SPG-CVR-C	22
76928	IBBK	140	77101	CRB-LS34W	14	77301	UTV1050	108	77389	SPG-CVR-C	79
76928	IBBK	141	77102	CRB-LS40W	14	77302	UTV1200	108	77389	SPG-CVR-C	107
76929	IBS-L4	138	77103	CRB-LS46W	14	77303	UTV1350	108	77390	SPG-CVR-D	22
76930	IBS-L5	138	77104	CRB-LS52W	14	77304	UTV1400	108	77390	SPG-CVR-D	79
76931	IBS-M4	139	77105	CRB-LS58W	14	77305	UTV1500	108	77390	SPG-CVR-D	107
76932	IBS-M5	139	77114	LS-BP	12	77306	UTV1600	108	77391	SPG-CVR-E	22
76933	IBS-H4	140	77115	LS-BP-S/S	13	77307	UTV1800	108	77391	SPG-CVR-E	79
76934	IBS-DH5	140	77117	LS-SW	12	77308	UTV2000	108	77391	SPG-CVR-E	107

INDEX By Item Code

Item Code	Ordering Number	Page #	Item Code	Ordering Number	Page #	Item Code	Ordering Number	Page #	Item Code	Ordering Number	Page #
77392	SPG-CVR-F	22	77499	MHS-P600*	76	77529	ISABK-LMH	138	77682	PTS-RR33	157
77392	SPG-CVR-F	79	77500	MHS-P750*	69	77529	ISABK-LMH	139	77683	PTS-RR39	157
77392	SPG-CVR-F	107	77500	MHS-P750*	74	77529	ISABK-LMH	140	77684	PTS-RR45	157
77393	SPG-CVR-G	22	77500	MHS-P750*	76	77548	SHIM-KITL	138	77685	PTS-RR51	157
77393	SPG-CVR-G	79	77501	MHS-P900*	69	77549	SHIM-KITM	139	77686	PTS-RR57	157
77393	SPG-CVR-G	107	77501	MHS-P900*	74	77550	SHIM-KITH	140	77687	PTS-RR63	157
77411	UTV2400	108	77501	MHS-P900*	76	77552	CRB-LS16HT	14	77689	PTS-RR75	157
77412	UTV2500	108	77502	MHS-P1050*	69	77553	CRB-LS22HT	14	77691	PTS-SR	158
77413	UTV2400-J	109	77502	MHS-P1050*	74	77554	CRB-LS28HT	14	77692	PTS-HDSR	158
77414	UTV2500-J	109	77502	MHS-P1050*	76	77555	CRB-LS34HT	14	77693	PTS-ABK	158
77417	UTV2400J-S/S	109	77503	MHS-P1350*	69	77556	CRB-LS40HT	14	77694	PTS-SAK	158
77418	USP98/2500-S/S	111	77503	MHS-P1350*	74	77557	CRB-LS46HT	14	77696	PTS-IBK	158
77418	UTV2500J-S/S	109	77503	MHS-P1350*	76	77558	CRB-LS52HT	14	77697	PTS-HIBK	158
77419	USP94/2400-S/S	111	77504	MHS-P1500*	69	77559	CRB-LS58HT	14	77698	PTS-PS	158
77421	URVB94/2400	108	77504	MHS-P1500*	74	77582	MSPMPK-S/S	27	77699	PTS-PA	158
77421	URVB94/2400	108	77504	MHS-P1500*	76	77583	MSPBPK-S/S	18	77700	PTS-MBK	158
77421	URVB94/2400	109	77505	MHS-P1800*	69	77584	QMT-P-S/S	27	77701	PTS-MBKUG	158
77421	URVB94/2400	109	77505	MHS-P1800*	74	77585	QMT-W-S/S	27	77702	PTS-EBK	158
77421	URVB94/2400	112	77505	MHS-P1800*	76	77586	QMT-G-S/S	27	77729	N/A	169
77422	URVB98/2500	108	77506	MHS-P2100*	69	77587	QMTPAK-S/S	27	77741	SPG-CVR-H	79
77422	URVB98/2500	108	77506	MHS-P2100*	74	77588	QMTPSBK-S/S	27	77741	SPG-CVR-H	107
77422	URVB98/2500	109	77506	MHS-P2100*	76	77590	MMPCP24-S/S	27	77742	CTS-W	97
77422	URVB98/2500	109	77507	MHS-P2400*	69	77591	MMPCP30-S/S	27	77743	CTS-S	61
77422	URVB98/2500	112	77507	MHS-P2400*	74	77592	MMPCP36-S/S	27	77743	CTS-S	97
77424	MMP-624-S/S	24	77507	MHS-P2400*	76	77593	MMPCP42-S/S	27	77744	CTS-B	97
77425	MMP-630-S/S	24	77508	MHS-P600S/S*	69	77594	MMPCP48-S/S	27	77745	CTS-G	97
77426	MMP-636-S/S	24	77508	MHS-P600S/S*	74	77595	MMPCP54-S/S	27	77746	EZP-LS212HT	10
77427	MMP-642-S/S	24	77508	MHS-P600S/S*	76	77596	MMPCP60-S/S	27	77747	EZP-LS218HT	10
77428	MMP-648-S/S	24	77509	MHS-P750S/S*	69	77597	MMPCP72-S/S	27	77748	EZP-LS224HT	10
77429	MMP-654-S/S	2	77509	MHS-P750S/S*	74	77598	MMPCP84-S/S	27	77749	EZP-LS230HT	10
77430	MMP-660-S/S	24	77509	MHS-P750S/S*	76	77599	MHP-EP-S/S	27	77750	EZP-LS236HT	10
77431	MMP-672-S/S	24	77510	MHS-P900S/S*	69	77599	MHP-EP-S/S	48	77751	EZP-LS242HT	10
77432	MMP-684-S/S	24	77510	MHS-P900S/S*	74	77599	MHP-EP-S/S	54	77752	EZP-LS248HT	10
77442	PSTA-S/S	27	77510	MHS-P900S/S*	76	77599	MHP-EP-S/S	84	77753	EZP-LS254HT	10
77443	TEN-LOCK-KIT	22	77511	MHS-P1050S/S*	69	77599	MHP-EP-S/S	91	77754	EZP-LS260HT	10
77443	TEN-LOCK-KIT	79	77511	MHS-P1050S/S*	74	77599	MHP-EP-S/S	98	77755	PTS-RHSAA	158
77443	TEN-LOCK-KIT	107	77511	MHS-P1050S/S*	76	77599	MHP-EP-S/S	104	77756	PTS-LHSAA	158
77448	URCB94/2400	112	77512	MHS-P1350S/S*	69	77600	MMPBPK-S/S	27	77789	MHS-600FPV	75
77449	URCB98/2500	112	77512	MHS-P1350S/S*	74	77630	STS-W-S/S	69	77790	MHS-750FPV	75
77450	QMTS-P-S/S	18	77512	MHS-P1350S/S*	76	77630	STS-W-S/S	76	77791	MHS-900FPV	75
77450	QMTS-P-S/S	27	77513	MHS-P1500S/S*	69	77630	STS-W-S/S	99	77792	MHS-1050FPV	75
77450	QMTS-P-SS	111	77513	MHS-P1500S/S*	74	77631	STS-S-S/S	69	77793	MHS-1200FPV	75
77451	QMTS-W-S/S	18	77513	MHS-P1500S/S*	76	77631	STS-S-S/S	76	77794	MHS-1350FPV	75
77451	QMTS-W-SS	111	77514	MHS-P1800S/S*	69	77631	STS-S-S/S	99	77795	MHS-1500FPV	75
77451	QSTS-W-S/S	27	77514	MHS-P1800S/S*	74	77632	STS-B-S/S	55	77796	MHS-1800FPV	75
77452	QMTS-G-S/S	18	77514	MHS-P1800S/S*	76	77632	STS-B-S/S	55	77797	MHS-2100FPV	75
77452	QMTS-G-S/S	27	77515	MHS-P2100S/S*	69	77632	STS-B-S/S	69	77798	MHS-2400FPV	75
77452	QMTS-G-SS	111	77515	MHS-P2100S/S*	74	77632	STS-B-S/S	76	77799	MHS-600FPV-S/S	75
77481	MHS-600BTV	73	77515	MHS-P2100S/S*	76	77632	STS-B-S/S	99	77800	MHS-750FPV-S/S	75
77482	MHS-750BTV	73	77516	MHS-P2400S/S*	69	77633	STHDPM2-S/S	76	77801	MHS-900FPV-S/S	75
77483	MHS-900BTV	73	77516	MHS-P2400S/S*	74	77633	STHDPM2-S/S	99	77802	MHS-1050FPV-S/S	75
77484	MHS-1050BTV	73	77516	MHS-P2400S/S*	76	77634	STHDMK2-S/S	76	77803	MHS-1200FPV-S/S	75
77485	MHS-1350BTV	73	77518	HXF8SS-Blue	36	77634	STHDMK2-S/S	99	77804	MHS-1350FPV-S/S	75
77486	MHS-1500BTV	73	77518	HXF8SS-Blue	37	77635	STGK2	76	77805	MHS-1500FPV-S/S	75
77487	MHS-1800BTV	73	77519	HXF8S-Blue	36	77635	STGK2	76	77806	MHS-1800FPV-S/S	75
77488	MHS-2100BTV	73	77519	HXF8S-Blue	37	77635	STGK2	97	77807	MHS-2100FPV-S/S	75
77489	MHS-2400BTV	73	77520	HXF8M-Blue	36	77635	STGK2	99	77808	MHS-2400FPV-S/S	75
77490	MHS-600BTV-S/S	73	77520	HXF8M-Blue	37	77664	PTS-18R	157	77866	SAC2-TIP-TL	83
77491	MHS-750BTV-S/S	73	77521	HXF8L-Blue	36	77665	PTS-24R	157	77866	SAC2-TIP-TL	85
77492	MHS-900BTV-S/S	73	77521	HXF8L-Blue	37	77666	PTS-30R	157	77866	SAC2-TIP-TL	90
77493	MHS-1050BTV-S/S	73	77525	MHS-1200BTV	73	77667	PTS-36R	157	77866	SAC2-TIP-TL	92
77494	MHS-1350BTV-S/S	73	77526	MHS-1200BTV-S/S	73	77668	PTS-42R	157	77866	SAC2-TIP-TL	97
77495	MHS-1500BTV-S/S	73	77527	MHS-P1200*	69	77669	PTS-48R	157	77866	SAC2-TIP-TL	99
77496	MHS-1800BTV-S/S	73	77527	MHS-P1200*	74	77670	PTS-54R	157	77866	SAC2-TIP-TL	103
77497	MHS-2100BTV-S/S	73	77527	MHS-P1200*	76	77671	PTS-60R	157	77866	SAC2-TIP-TL	105
77498	MHS-2400BTV-S/S	73	77528	MHS-P1200S/S*	69	77672	PTS-72R	157	77868	SSTHDPM	76
77499	MHS-P600*	69	77528	MHS-P1200S/S*	74	77680	PTS-RR21	157	77868	SSTHDPM	97
77499	MHS-P600*	74	77528	MHS-P1200S/S*	76	77681	PTS-RR27	157	77869	CSTHDPM	97

INDEX By Item Code

Item Code	Ordering Number	Page #	Item Code	Ordering Number	Page #	Item Code	Ordering Number	Page #	Item Code	Ordering Number	Page #
77870	SSTHDMK	76	77896	SACPL2-72/1800	89	78018	MHS-2400BTV-2SAC	101	78171	MHS-1800V-2SAC	94
77870	SSTHDMK	96	77896	SACPL2-72/1800	96	78019	MHS-3000BTV-2SAC	101	78172	MHS-2100V-2SAC	94
77871	CSTHDMK	97	77896	SACPL2-72/1800	103	78020	PV600-SAC	80	78173	MHS-2400V-2SAC	94
77882	SACRKN	47	77897	SACPL2-84/2100	82	78021	PV750-SAC	80	78174	MHS-3000V-2SAC	94
77882	SACRKN	83	77897	SACPL2-84/2100	89	78022	PV900-SAC	80	78316	MHS-600BTV-SAC-S/S	101
77882	SACRKN	85	77897	SACPL2-84/2100	96	78023	PV1050-SAC	80	78317	MHS-750BTV-SAC-S/S	101
77882	SACRKN	90	77897	SACPL2-84/2100	103	78024	PV1200-SAC	80	78318	MHS-900BTV-SAC-S/S	101
77882	SACRKN	92	77898	SACPL2-96/2400	82	78025	PV1350-SAC	80	78319	MHS-1050BTV-SAC-S/S	101
77882	SACRKN	97	77898	SACPL2-96/2400	89	78026	PV1500-SAC	80	78320	MHS-1200BTV-SAC-S/S	101
77882	SACRKN	99	77898	SACPL2-96/2400	96	78027	PV1800-SAC	80	78321	MHS-1350BTV-SAC-S/S	101
77882	SACRKN	103	77898	SACPL2-96/2400	103	78028	PV1500-2SAC	80	78322	MHS-1500BTV-SAC-S/S	101
77882	SACRKN	105	77899	SACPL2-120/3000	82	78029	PV1800-2SAC	80	78323	MHS-1800BTV-SAC-S/S	101
77883	SACRH	47	77899	SACPL2-120/3000	89	78030	PV2100-2SAC	80	78324	MHS-1500BTV-2SAC-S/S	101
77883	SACRH	83	77899	SACPL2-120/3000	96	78031	PV2400-2SAC	80	78325	MHS-1800BTV-2SAC-S/S	101
77883	SACRH	90	77899	SACPL2-120/3000	103	78032	PV3000-2SAC	80	78326	MHS-2100BTV-2SAC-S/S	101
77883	SACRH	97	77913	PCAP-24/600	83	78033	RV600-SAC	87	78327	MHS-2400BTV-2SAC-S/S	101
77883	SACRH	103	77914	PCAP-30/750	83	78034	RV750-SAC	87	78328	MHS-3000BTV-2SAC-S/S	101
77884	SACRHL	47	77915	PCAP-36/900	83	78035	RV900-SAC	87	78329	PV600-SAC-S/S	80
77884	SACRHL	83	77916	PCAP-42/1050	83	78036	RV1050-SAC	87	78330	PV750-SAC-S/S	80
77884	SACRHL	90	77917	PCAP-48/1200	83	78037	RV1200-SAC	87	78331	PV900-SAC-S/S	80
77884	SACRHL	97	77918	PCAP-54/1350	83	78038	RV1350-SAC	87	78332	PV1050-SAC-S/S	80
77884	SACRHL	103	77919	PCAP-60/1500	83	78039	RV1500-SAC	87	78333	PV1200-SAC-S/S	80
77885	SACKRP	47	77920	PCAP-72/1800	83	78040	RV1800-SAC	87	78334	PV1350-SAC-S/S	80
77885	SACKRP	83	77921	RCAP-24/600	90	78041	RV1500-2SAC	87	78335	PV1500-SAC-S/S	80
77885	SACKRP	90	77922	RCAP-30/750	90	78042	RV1800-2SAC	87	78336	PV1800-SAC-S/S	80
77885	SACKRP	97	77923	RCAP-36/900	90	78043	RV2100-2SAC	87	78337	PV1500-2SAC-S/S	80
77885	SACKRP	103	77924	RCAP-42/1050	90	78044	RV2400-2SAC	87	78338	PV1800-2SAC-S/S	80
77886	SACRKT	83	77925	RCAP-48/1200	90	78045	RV3000-2SAC	87	78339	PV2100-2SAC-S/S	80
77886	SACRKT	90	77926	RCAP-54/1350	90	78080	P-CARK-V24/600	81	78340	PV2400-2SAC-S/S	80
77886	SACRKT	97	77927	RCAP-60/1500	90	78081	P-CARK-V30/750	81	78341	PV3000-2SAC-S/S	80
77886	SACRKT	103	77928	RCAP-72/1800	90	78082	P-CARK-V36/900	81	78342	RV600-SAC-S/S	87
77887	SACPL-24/600	82	77937	MHS-CARK-V24/600	95	78083	P-CARK-V42/1050	81	78343	RV750-SAC-S/S	87
77887	SACPL-24/600	89	77937	MHS-CARK-V24/600	102	78084	P-CARK-V48/1200	81	78344	RV900-SAC-S/S	87
77887	SACPL-24/600	96	77938	MHS-CARK-V30/750	95	78085	P-CARK-V54/1350	81	78345	RV1050-SAC-S/S	87
77887	SACPL-24/600	103	77938	MHS-CARK-V30/750	102	78086	P-CARK-V60/1500	81	78346	RV1200-SAC-S/S	87
77888	SACPL-30/750	82	77939	MHS-CARK-V36/900	95	78087	P-CARK-V72/1800	81	78347	RV1350-SAC-S/S	87
77888	SACPL-30/750	89	77939	MHS-CARK-V36/900	102	78093	P-CARK2-V60/1500	81	78348	RV1500-SAC-S/S	87
77888	SACPL-30/750	96	77940	MHS-CARK-V42/1050	95	78094	P-CARK2-V72/1800	81	78349	RV1800-SAC-S/S	87
77888	SACPL-30/750	103	77940	MHS-CARK-V42/1050	102	78095	P-CARK2-V84/2100	81	78350	RV1500-2SAC-S/S	87
77889	SACPL-36/900	82	77941	MHS-CARK-V48/1200	95	78096	P-CARK2-V96/2400	81	78351	RV1800-2SAC-S/S	87
77889	SACPL-36/900	89	77941	MHS-CARK-V48/1200	102	78097	P-CARK2-V120/3000	81	78352	RV2100-2SAC-S/S	87
77889	SACPL-36/900	96	77942	MHS-CARK-V54/1350	95	78106	R-CARK-V24/600	88	78353	RV2400-2SAC-S/S	87
77889	SACPL-36/900	103	77942	MHS-CARK-V54/1350	102	78107	R-CARK-V30/750	88	78354	RV3000-2SAC-S/S	87
77890	SACPL-42/1050	82	77943	MHS-CARK-V60/1500	95	78108	R-CARK-V36/900	88	78355	PCAP-24/600-S/S	85
77890	SACPL-42/1050	89	77943	MHS-CARK-V60/1500	102	78109	R-CARK-V42/1050	88	78356	PCAP-30/750-S/S	85
77890	SACPL-42/1050	96	77944	MHS-CARK-V72/1800	95	78110	R-CARK-V48/1200	88	78357	PCAP-36/900-S/S	85
77890	SACPL-42/1050	103	77944	MHS-CARK-V72/1800	102	78111	R-CARK-V54/1350	88	78358	PCAP-42/1050-S/S	85
77891	SACPL-48/1200	82	77950	MHS-CARK2-V60/1500	95	78112	R-CARK-V60/1500	88	78359	PCAP-48/1200-S/S	85
77891	SACPL-48/1200	89	77950	MHS-CARK2-V60/1500	102	78113	R-CARK-V72/1800	88	78360	PCAP-54/1350-S/S	85
77891	SACPL-48/1200	96	77951	MHS-CARK2-V72/1800	95	78119	R-CARK2-V60/1500	88	78361	PCAP-60/1500-S/S	85
77891	SACPL-48/1200	103	77951	MHS-CARK2-V72/1800	102	78120	R-CARK2-V72/1800	88	78362	PCAP-72/1800-S/S	85
77892	SACPL-54/1350	82	77952	MHS-CARK2-V84/2100	95	78121	R-CARK2-V84/2100	88	78363	RCAP-24/600-S/S	92
77892	SACPL-54/1350	89	77952	MHS-CARK2-V84/2100	102	78122	R-CARK2-V96/2400	88	78364	RCAP-30/750-S/S	92
77892	SACPL-54/1350	96	77953	MHS-CARK2-V96/2400	95	78123	R-CARK2-V120/3000	88	78365	RCAP-36/900-S/S	92
77892	SACPL-54/1350	103	77953	MHS-CARK2-V96/2400	102	78142	STS-G	55	78366	RCAP-42/1050-S/S	92
77893	SACPL-60/1500	82	77954	MHS-CARK2-V120/3000	95	78142	STS-G	55	78367	RCAP-48/1200-S/S	92
77893	SACPL-60/1500	89	77954	MHS-CARK2-V120/3000	102	78142	STS-G	69	78368	RCAP-54/1350-S/S	92
77893	SACPL-60/1500	96	78007	MHS-600BTV-SAC	101	78142	STS-G	76	78369	RCAP-60/1500-S/S	92
77893	SACPL-60/1500	103	78008	MHS-750BTV-SAC	101	78142	STS-G	97	78370	RCAP-72/1800-S/S	92
77894	SACPL-72/1800	82	78009	MHS-900BTV-SAC	101	78162	MHS-600V-SAC	94	78371	SACPL-24/600-S/S	84
77894	SACPL-72/1800	89	78010	MHS-1050BTV-SAC	101	78163	MHS-750V-SAC	94	78371	SACPL-24/600-S/S	91
77894	SACPL-72/1800	96	78011	MHS-1200BTV-SAC	101	78164	MHS-900V-SAC	94	78371	SACPL-24/600-S/S	98
77894	SACPL-72/1800	103	78012	MHS-1350BTV-SAC	101	78165	MHS-1050V-SAC	94	78371	SACPL-24/600-S/S	104
77895	SACPL2-60/1500	82	78013	MHS-1500BTV-SAC	101	78166	MHS-1200V-SAC	94	78372	SACPL-30/750-S/S	84
77895	SACPL2-60/1500	89	78014	MHS-1800BTV-SAC	101	78167	MHS-1350V-SAC	94	78372	SACPL-30/750-S/S	91
77895	SACPL2-60/1500	96	78015	MHS-1500BTV-2SAC	101	78168	MHS-1500V-SAC	94	78372	SACPL-30/750-S/S	98
77895	SACPL2-60/1500	103	78016	MHS-1800BTV-2SAC	101	78169	MHS-1800V-SAC	94	78372	SACPL-30/750-S/S	104
77896	SACPL2-72/1800	82	78017	MHS-2100BTV-2SAC	101	78170	MHS-1500V-2SAC	94	78373	SACPL-36/900-S/S	84

INDEX By Item Code

Item Code	Ordering Number	Page #	Item Code	Ordering Number	Page #	Item Code	Ordering Number	Page #	Item Code	Ordering Number	Page #
78373	SACPL-36/900-S/S	91	78399	SACKRP-S/S	85	78576	CART-24/600-S/S	103	78584	CART2-60/1500-S/S	48
78373	SACPL-36/900-S/S	98	78399	SACKRP-S/S	92	78576	CART-24/600-S/S	104	78584	CART2-60/1500-S/S	54
78373	SACPL-36/900-S/S	104	78399	SACKRP-S/S	99	78577	CART-30/750-S/S	82	78584	CART2-60/1500-S/S	82
78374	SACPL-42/1050-S/S	84	78399	SACKRP-S/S	105	78577	CART-30/750-S/S	84	78584	CART2-60/1500-S/S	84
78374	SACPL-42/1050-S/S	91	78401	SACRKT-S/S	85	78577	CART-30/750-S/S	89	78584	CART2-60/1500-S/S	89
78374	SACPL-42/1050-S/S	98	78401	SACRKT-S/S	92	78577	CART-30/750-S/S	91	78584	CART2-60/1500-S/S	91
78374	SACPL-42/1050-S/S	104	78401	SACRKT-S/S	99	78577	CART-30/750-S/S	96	78584	CART2-60/1500-S/S	96
78375	SACPL-48/1200-S/S	84	78401	SACRKT-S/S	105	78577	CART-30/750-S/S	98	78584	CART2-60/1500-S/S	96
78375	SACPL-48/1200-S/S	91	78456	SSFRB	32	78577	CART-30/750-S/S	103	78584	CART2-60/1500-S/S	103
78375	SACPL-48/1200-S/S	98	78456	SSFRB	35	78577	CART-30/750-S/S	104	78584	CART2-60/1500-S/S	105
78375	SACPL-48/1200-S/S	104	78462	LSTMPK2-S/S	13	78578	CART-36/900-S/S	47	78585	CART2-72/1800-S/S	48
78376	SACPL-54/1350-S/S	84	78472	CRB-W16	19	78578	CART-36/900-S/S	53	78585	CART2-72/1800-S/S	54
78376	SACPL-54/1350-S/S	91	78473	CRB-W22	19	78578	CART-36/900-S/S	82	78585	CART2-72/1800-S/S	82
78376	SACPL-54/1350-S/S	98	78474	CRB-W28	19	78578	CART-36/900-S/S	84	78585	CART2-72/1800-S/S	84
78376	SACPL-54/1350-S/S	104	78475	CRB-W34	19	78578	CART-36/900-S/S	89	78585	CART2-72/1800-S/S	89
78377	SACPL-60/1500-S/S	84	78476	CRB-W40	19	78578	CART-36/900-S/S	91	78585	CART2-72/1800-S/S	91
78377	SACPL-60/1500-S/S	91	78477	CRB-W46	19	78578	CART-36/900-S/S	96	78585	CART2-72/1800-S/S	96
78377	SACPL-60/1500-S/S	98	78478	CRB-W52	19	78578	CART-36/900-S/S	98	78585	CART2-72/1800-S/S	98
78377	SACPL-60/1500-S/S	104	78479	CRB-W58	19	78578	CART-36/900-S/S	103	78585	CART2-72/1800-S/S	103
78378	SACPL-72/1800-S/S	84	78480	CRB-W64	19	78578	CART-36/900-S/S	104	78585	CART2-72/1800-S/S	105
78378	SACPL-72/1800-S/S	91	78481	CRB-W70	19	78579	CART-42/1050-S/S	47	78586	CART2-84/2100-S/S	48
78378	SACPL-72/1800-S/S	98	78488	EZP1T-212	20	78579	CART-42/1050-S/S	53	78586	CART2-84/2100-S/S	54
78378	SACPL-72/1800-S/S	104	78489	EZP1T-218	20	78579	CART-42/1050-S/S	82	78586	CART2-84/2100-S/S	82
78379	SACPL2-60/1500-S/S	84	78490	EZP1T-224	20	78579	CART-42/1050-S/S	84	78586	CART2-84/2100-S/S	84
78379	SACPL2-60/1500-S/S	91	78491	EZP1T-230	20	78579	CART-42/1050-S/S	89	78586	CART2-84/2100-S/S	89
78379	SACPL2-60/1500-S/S	98	78492	EZP1T-236	20	78579	CART-42/1050-S/S	91	78586	CART2-84/2100-S/S	91
78379	SACPL2-60/1500-S/S	104	78493	EZP1T-242	20	78579	CART-42/1050-S/S	96	78586	CART2-84/2100-S/S	96
78380	SACPL2-72/1800-S/S	84	78494	EZP1T-248	20	78579	CART-42/1050-S/S	98	78586	CART2-84/2100-S/S	98
78380	SACPL2-72/1800-S/S	91	78495	EZP1T-254	20	78579	CART-42/1050-S/S	103	78586	CART2-84/2100-S/S	103
78380	SACPL2-72/1800-S/S	98	78496	EZP1T-260	20	78579	CART-42/1050-S/S	104	78586	CART2-84/2100-S/S	105
78380	SACPL2-72/1800-S/S	104	78497	EZP1T-272	20	78580	CART-48/1200-S/S	82	78587	CART2-96/2400-S/S	48
78381	SACPL2-84/2100-S/S	84	78507	EZPTMPK	21	78580	CART-48/1200-S/S	84	78587	CART2-96/2400-S/S	54
78381	SACPL2-84/2100-S/S	91	78508	EZPTCK	21	78580	CART-48/1200-S/S	89	78587	CART2-96/2400-S/S	82
78381	SACPL2-84/2100-S/S	98	78509	EZPTCKHD	21	78580	CART-48/1200-S/S	91	78587	CART2-96/2400-S/S	84
78381	SACPL2-84/2100-S/S	104	78510	EZPTSR	21	78580	CART-48/1200-S/S	96	78587	CART2-96/2400-S/S	89
78382	SACPL2-96/2400-S/S	84	78511	EZPTSK	21	78580	CART-48/1200-S/S	98	78587	CART2-96/2400-S/S	91
78382	SACPL2-96/2400-S/S	91	78512	EZPTSKHD	21	78580	CART-48/1200-S/S	103	78587	CART2-96/2400-S/S	96
78382	SACPL2-96/2400-S/S	98	78513	CST1HDM-W	97	78580	CART-48/1200-S/S	104	78587	CART2-96/2400-S/S	98
78382	SACPL2-96/2400-S/S	104	78514	CST1HDM-S	97	78580	CART2-48/1200-S/S	47	78587	CART2-96/2400-S/S	103
78383	SACPL2-120/3000-S/S	84	78515	CST1HDM-B	97	78580	CART2-48/1200-S/S	53	78587	CART2-96/2400-S/S	105
78383	SACPL2-120/3000-S/S	91	78516	CST1HDM-G	97	78581	CART-54/1350-S/S	82	78588	CART2-120/3000-S/S	48
78383	SACPL2-120/3000-S/S	98	78517	SST1HDM-W	76	78581	CART-54/1350-S/S	84	78588	CART2-120/3000-S/S	54
78383	SACPL2-120/3000-S/S	104	78517	SST1HDM-W	97	78581	CART-54/1350-S/S	89	78588	CART2-120/3000-S/S	82
78384	CSTHDMK-S/S	99	78518	SST1HDM-S	76	78581	CART-54/1350-S/S	91	78588	CART2-120/3000-S/S	84
78385	CTS-W-S/S	99	78518	SST1HDM-S	97	78581	CART-54/1350-S/S	96	78588	CART2-120/3000-S/S	89
78386	CTS-S-S/S	99	78519	SST1HDM-B	76	78581	CART-54/1350-S/S	98	78588	CART2-120/3000-S/S	91
78387	CTS-B-S/S	13	78519	SST1HDM-B	97	78581	CART-54/1350-S/S	103	78588	CART2-120/3000-S/S	96
78387	CTS-B-S/S	99	78537	MHS-600V-SAC-S/S	94	78581	CART-54/1350-S/S	104	78588	CART2-120/3000-S/S	98
78388	CTS-G-S/S	99	78538	MHS-750V-SAC-S/S	94	78582	CART-60/1500-S/S	47	78588	CART2-120/3000-S/S	103
78389	CSTHDPM-S/S	99	78539	MHS-900V-SAC-S/S	94	78582	CART-60/1500-S/S	53	78588	CART2-120/3000-S/S	105
78390	CST1HDM-W-S/S	99	78540	MHS-1050V-SAC-S/S	94	78582	CART-60/1500-S/S	82	78634	CART2-66/1650-S/S	48
78391	CST1HDM-S-S/S	99	78541	MHS-1200V-SAC-S/S	94	78582	CART-60/1500-S/S	84	78634	CART2-66/1650-S/S	54
78392	CST1HDM-B-S/S	99	78542	MHS-1350V-SAC-S/S	94	78582	CART-60/1500-S/S	89	78635	CART2-78/1950-S/S	48
78393	CST1HDM-G-S/S	99	78543	MHS-1500V-SAC-S/S	94	78582	CART-60/1500-S/S	91	78635	CART2-78/1950-S/S	54
78394	SST1HDM-W-S/S	76	78544	MHS-1800V-SAC-S/S	94	78582	CART-60/1500-S/S	96	78635	CART2-78/1950-S/S	82
78394	SST1HDM-W-S/S	99	78545	MHS-1500V-2SAC-S/S	94	78582	CART-60/1500-S/S	98	78635	CART2-78/1950-S/S	84
78395	SST1HDM-S-S/S	76	78546	MHS-1800V-2SAC-S/S	94	78582	CART-60/1500-S/S	103	78635	CART2-78/1950-S/S	89
78395	SST1HDM-S-S/S	99	78547	MHS-2100V-2SAC-S/S	94	78582	CART-60/1500-S/S	104	78635	CART2-78/1950-S/S	91
78396	SST1HDM-B-S/S	76	78548	MHS-2400V-2SAC-S/S	94	78583	CART-72/1800-S/S	47	78635	CART2-78/1950-S/S	96
78396	SST1HDM-B-S/S	99	78549	MHS-3000V-2SAC-S/S	94	78583	CART-72/1800-S/S	53	78635	CART2-78/1950-S/S	98
78397	SACRH-S/S	85	78576	CART-24/600-S/S	47	78583	CART-72/1800-S/S	82	78635	CART2-78/1950-S/S	103
78397	SACRH-S/S	92	78576	CART-24/600-S/S	53	78583	CART-72/1800-S/S	84	78635	CART2-78/1950-S/S	105
78397	SACRH-S/S	99	78576	CART-24/600-S/S	82	78583	CART-72/1800-S/S	89	78639	CART2-114/2850-S/S	48
78397	SACRH-S/S	105	78576	CART-24/600-S/S	84	78583	CART-72/1800-S/S	91	78639	CART2-114/2850-S/S	54
78398	SACRHL-S/S	85	78576	CART-24/600-S/S	89	78583	CART-72/1800-S/S	96	78640	CART2-126/3150-S/S	48
78398	SACRHL-S/S	92	78576	CART-24/600-S/S	91	78583	CART-72/1800-S/S	98	78640	CART2-126/3150-S/S	54
78398	SACRHL-S/S	99	78576	CART-24/600-S/S	96	78583	CART-72/1800-S/S	103	78642	SACPL2-78/1950-S/S	84
78398	SACRHL-S/S	105	78576	CART-24/600-S/S	98	78583	CART-72/1800-S/S	104	78642	SACPL2-78/1950-S/S	91

INDEX By Item Code

Item Code	Ordering Number	Page #	Item Code	Ordering Number	Page #	Item Code	Ordering Number	Page #	Item Code	Ordering Number	Page #
78642	SACPL2-78/1950-S/S	98	79025	HDRR60	124	79281	PTPHD96R	160	79529	MBCM-1	116
78642	SACPL2-78/1950-S/S	104	79026	HDRRS72*	124	79288	ESS-S-S/S	111	79530	MBCM-2	116
78649	MHS-1950BTV-2SAC-S/S	101	79027	HDRRS84*	124	79289	PFC-P-S/S	64	79531	MBCTA	116
78649	MHS-1950V-2SAC-S/S	94	79056	PSTS-S-S/S	55	79378	MSR-S/S	164	79532	MBCBL	116
78656	PV1950-2SAC-S/S	80	79057	STS-G-S/S	55	79431	MSTHD-W	69	79533	MBCMCK	116
78663	RV1950-2SAC-S/S	87	79057	STS-G-S/S	55	79432	MSTHD-S	69	79534	MBCEC	116
78683	PACB60	72	79057	STS-G-S/S	69	79433	MSTHD-B	69	79535	STLP	116
78683	PACB60	77	79069	SST1HDM-G	76	79434	MSTDB	72	79536	MBCDBK	114
78683	PACB60	97	79069	SST1HDM-G	97	79435	MSTAM	69	79536	MBCDBK	116
78684	PAT1	29	79070	SSTHK	76	79436	MST-MBL	72	79573	YT-P*	58
78685	PAT2	29	79071	SSTHK-S/S	76	79437	MST-MBR	72	79574	YT-C*	58
78789	SB4	130	79072	HDRBK-HD	124	79440	MSTBK	69	79617	YCART-18/450-P	58
78789	SB4	132	79200	SPFC	74	79440	MSTBK	69	79618	YCART-24/600-P	58
78789	SB4	134	79200	SPFC	76	79470	PTPLB	162	79619	YCART-30/750-P	58
78789	SB4	136	79200	SPFC	96	79473	PTPLB-HD	162	79620	YCART-36/900-P	58
78790	SB5	130	79200	SPFC	103	79476	PTP-RPA	162	79621	YCART-42/1050-P	58
78790	SB5	132	79201	SPFC-S/S	74	79478	PTP-HDRPA	162	79622	YCART-48/1200-P	58
78790	SB5	134	79201	SPFC-S/S	76	79484	PTP-EBKR	162	79623	YTAC	61
78790	SB5	136	79201	SPFC-S/S	99	79486	PTP-HDEBKR	162	79647	FMS-600V	67
78791	PATLK	29	79201	SPFC-S/S	105	79488	PTP-LS	162	79647	FMS-600V-S/S	67
78794	PATHK	29	79206	USPB	110	79490	PTP-RMB	162	79648	FMS-750V	67
78808	EST-P-S/S	18	79206	USPB	111	79491	PTP-RRB	162	79648	FMS-750V-S/S	67
78809	EST-W-S/S	18	79206	USPB2	110	79492	PTP-HDRBK	162	79649	FMS-900V	67
78810	EST-G-S/S	18	79206	USPB2	111	79494	MBC-18	114	79649	FMS-900V-S/S	67
78812	EZP1P12-S/S	18	79207	UHPB2	110	79495	MBC-24	114	79650	FMS-1050V	67
78838	CFG-212	15	79207	UHPB2	111	79496	MBC-30	114	79650	FMS-1050V-S/S	67
78839	CFG-218	15	79224	CCKL	64	79497	MBC-36	114	79651	FMS-1200V	67
78840	CFG-224	15	79224	CCKL	66	79498	MBC-42	114	79651	FMS-1200V-S/S	67
78841	CFG-230	15	79225	CCKHDL	64	79499	MBC-48	114	79652	FMS-1350V	67
78842	CFG-236	15	79225	CCKHDL	66	79500	MBC-54	114	79652	FMS-1350V-S/S	67
78843	CFG-242	15	79225	CCKHDL	74	79501	MBC-60	114	79653	FMS-1500V	67
78844	CFG-248	15	79226	CCKL-S/S	64	79502	MBC-72	114	79653	FMS-1500V-S/S	67
78845	CFG-254	15	79226	CCKL-S/S	66	79503	MBC-84	114	79654	FMS-1800V	67
78846	CFG-260	15	79227	CCKHDL-S/S	64	79504	MBDS-18	116	79654	FMS-1800V-S/S	67
78847	CFG-272	15	79227	CCKHDL-S/S	66	79505	MBDS-24	116	79656	PACB100	72
78848	EZP1PL-S/S	18	79227	CCKHDL-S/S	74	79506	MBDS-30	116	79656	PACB100	77
78849	ESTAK-EST-S/S	18	79228	CCKR	64	79507	MBDS-36	116	79656	PACB100	97
78849	ESTAK-EST-S/S	55	79228	CCKR	66	79508	MBDS-42	116	79677	YT-HDP*	58
78849	ESTAK-SS	111	79229	CCKHDR	64	79509	MBDS-48	116	79699	FMSC	69
78850	LS-SW-S/S	13	79229	CCKHDR	66	79510	MBDS-54	116	79699	FMSC	69
78919	CCMK	64	79229	CCKHDR	74	79511	MBDS-60	116	79728	YT-HDC*	58
78919	CCMK	66	79230	CCKR-S/S	64	79512	MBDS-72	116	79795	YSTS-Y	61
78920	CCMKHD	64	79230	CCKR-S/S	66	79513	MBDS-84	116	79796	YSTS-P	61
78920	CCMKHD	66	79231	CCKHDR-S/S	64	79514	MBRD-18	114	79797	YSTHDS-GR	62
78920	CCMKHD	74	79231	CCKHDR-S/S	66	79514	MBRD-18	116	79798	YSTHDS-BL	62
78921	CCMK-S/S	64	79231	CCKHDR-S/S	74	79515	MBRD-24	114	79805	YTAHD-36/900	62
78921	CCMK-S/S	66	79232	CCKTS	64	79515	MBRD-24	116	79806	YTAHD-42/1050	62
78922	CCMKHD-S/S	64	79232	CCKTS	66	79516	MBRD-30	114	79807	YTAHD-48/1200	62
78922	CCMKHD-S/S	66	79233	CCKHDT	64	79516	MBRD-30	116	79808	YTAHD-54/1350	62
78922	CCMKHD-S/S	74	79233	CCKHDT	66	79517	MBRD-36	114	79809	YTAHD-60/1500	62
78923	EZP1MPK-S/S	18	79233	CCKHDT	74	79517	MBRD-36	116	79810	YTAHD-72/1800	62
78933	LSTMPK-S/S	13	79234	CCKTS-S/S	64	79518	MBRD-42	114	79811	YCART-18/450-TC	58
79009	HDRBK	124	79234	CCKTS-S/S	66	79518	MBRD-42	116	79812	YCART-24/600-TC	58
79010	HDR24	124	79236	HDRGEK	124	79519	MBRD-48	114	79813	YCART-30/750-TC	58
79011	HDR30	124	79267	PTP18R	160	79519	MBRD-48	116	79814	YCART-36/900-TC	58
79012	HDR36	124	79268	PTP24R	160	79520	MBRD-54	114	79815	YCART-42/1050-TC	58
79013	HDR42	124	79269	PTP30R	160	79520	MBRD-54	116	79816	YCART-48/1200-TC	58
79014	HDR48	124	79270	PTP36R	160	79521	MBRD-60	114	79817	YCART-36/900-HDP	58
79015	HDR54	124	79271	PTP42R	160	79521	MBRD-60	116	79818	YCART-42/1050-HDP	58
79016	HDR60	124	79272	PTP48R	160	79522	MBRD-72	114	79819	YCART-48/1200-HDP	58
79017	HDRS72*	124	79273	PTP54R	160	79522	MBRD-72	116	79820	YCART-54/1350-HDP	58
79018	HDRS84*	124	79274	PTP60R	160	79523	MBRD-84	114	79821	YCART-60/1500-HDP	58
79019	HDRR24	124	79275	PTP72R	160	79523	MBRD-84	116	79822	YCART-72/1800-HDP	58
79020	HDRR30	124	79276	PTPHD48R	160	79524	MBCMCK	116	79829	YCART-36/900-HDTC	58
79021	HDRR36	124	79277	PTPHD54R	160	79525	MBCBC	116	79830	YCART-42/1050-HDTC	58
79022	HDRR42	124	79278	PTPHD60R	160	79526	MBCB	116	79831	YCART-48/1200-HDTC	58
79023	HDRR48	124	79279	PTPHD72R	160	79527	MBADB	116	79832	YCART-54/1350-HDTC	58
79024	HDRR54	124	79280	PTPHD84R	160	79528	MBCBM	116	79833	YCART-60/1500-HDTC	58

INDEX By Item Code

Item Code	Ordering Number	Page #	Item Code	Ordering Number	Page #	Item Code	Ordering Number	Page #	Item Code	Ordering Number	Page #
79834	YCARD-72/1800-HDTC	58	82217	EZIB600-1200L	133	82348	EZWPK-1050	136	82690	USP24/600	110
79835	YTACHD	62	82218	EZIB750-1200L	133	82349	EZWPK-1200	130	82691	USP30/750	110
79836	YST-Y	61	82219	EZIB900-1200L	133	82349	EZWBK-1200	132	82692	USP36/900	110
79837	YST-P	61	82220	EZIB1050-1200L	133	82349	EZWPK-1200	134	82693	USP42/1050	110
79838	YST-S	61	82221	EZIB1200-1200L	133	82349	EZWPK-1200	136	82694	USP48/1200	110
79839	YSTHD-GR	62	82222	EZIB1350-1200L	133	82350	EZWPK-1350	130	82695	USP54/1350	110
79840	YSTHD-S	62	82223	EZIB1500-1200L	133	82350	EZWPK-1350	134	82696	USP56/1400	110
79841	YSTHD-BL	62	82224	EZIB1800-1200L	133	82350	EZWPK-1350	136	82697	USP60/1500	110
79842	YSTHD-BK	62	82225	EZIB600-1500L	133	82350	EZWPK-13500	132	82698	USP64/1600	110
79843	YSTMB	61	82226	EZIB750-1500L	133	82351	EZWPK-1500	130	82699	USP72/1800	110
79844	YSTDBK	61	82227	EZIB900-1500L	133	82351	EZWPK-1500	132	82700	USP80/2000	110
79845	YSTGBK	61	82228	EZIB1050-1500L	133	82351	EZWPK-1500	134	82701	USP84/2100	110
79846	YSTLBK	61	82229	EZIB1200-1500L	133	82351	EZWPK-1500	136	82702	USP88/2200	110
79847	YSTTBK-W	61	82230	EZIB1350-1500L	133	82352	EZWPK-1800	130	82703	USP94/2400	110
79848	YSTPMK	61	82231	EZIB1500-1500L	133	82352	EZWPK-1800	132	82704	USP98/2500	110
79849	YSTHDMB	62	82232	EZIB1800-1500L	133	82352	EZWPK-1800	134	82707	UTV450-S/S	108
79850	YSTHDDBK	62	82233	EZIB600-1200M	135	82352	EZWPK-1800	136	82708	UTV600-S/S	108
79851	YSTHDGBK	62	82234	EZIB750-1200M	135	82353	EZCSK-600	130	82709	UTV750-S/S	108
79852	YSTHDLBK	62	82235	EZIB900-1200M	135	82353	EZCSK-600	132	82710	UTV900-S/S	108
79853	YSTHDBK-W	62	82236	EZIB1050-1200M	135	82353	EZCSK-600	134	82711	UTV1050-S/S	108
79854	YSTPHDMK	62	82237	EZIB1200-1200M	135	82353	EZCSK-600	136	82712	UTV1200-S/S	108
79855	YSTTBK-B	61	82238	EZIB1350-1200M	135	82354	EZCSK-750	130	82713	UTV1350-S/S	108
79856	YSTHDBK-B	62	82239	EZIB1500-1200M	135	82354	EZCSK-750	132	82714	UTV1400-S/S	108
79857	YSTANK	61	82240	EZIB1800-1200M	135	82354	EZCSK-750	134	82715	UTV1500-S/S	108
79858	YSTANK	62	82241	EZIB600-1500M	135	82354	EZCSK-750	136	82716	UTV1600-S/S	108
81045	C-PSTA	110	82242	EZIB750-1500M	135	82355	EZCSK-900	130	82717	UTV1800-S/S	108
81250	RIBBK	130	82243	EZIB900-1500M	135	82355	EZCSK-900	132	82718	UTV2000-S/S	108
81250	RIBBK	132	82244	EZIB1050-1500M	135	82355	EZCSK-900	134	82719	UTV2100-S/S	108
81250	RIBBK	134	82245	EZIB1200-1500M	135	82355	EZCSK-900	136	82720	UTV2200-S/S	108
81250	RIBBK	136	82246	EZIB1350-1500M	135	82356	EZCSK-1050	130	82721	UTV2400-S/S	108
81896	MESPKR	110	82247	EZIB1500-1500M	135	82356	EZCSK-1050	132	82722	UTV2500-S/S	108
82174	QMTBK-GCN	110	82248	EZIB1800-1500M	135	82356	EZCSK-1050	134	82810	SCU60-S/S	111
82174	QMTBK-GCN	111	82281	EZBMK-600	134	82356	EZCSK-1050	136	82811	SCUHD-S/S	111
82175	QMTBK-WS-MT	110	82281	EZBMK-600	136	82357	EZCSK-1200	130	82812	SCU60	110
82175	QMTBK-WS-MT	111	82282	EZBMK-750	134	82357	EZCSK-1200	132	82813	SCUHD	110
82182	QMTPSBK-CN	110	82282	EZBMK-750	136	82357	EZCSK-1200	134	82815	P-CARK-V24/600-S/S PVECKS/S	81
82185	EZSB600-1200C	129	82283	EZBMK-900	136	82357	EZCSK-1200	136	82816	P-CARK-V30/750-S/S PVECKS/S	81
82186	EZSB750-1200C	129	82283	EZBMK-9000	134	82358	EZCSK-1350	130	82817	P-CARK-V36/900-S/S PVECKS/S	81
82187	EZSB900-1200C	129	82284	EZBMK-1050	134	82358	EZCSK-1350	132	82818	P-CARK-V42/1050-S/S PVECKS/S	81
82188	EZSB1050-1200C	129	82284	EZBMK-1050	136	82358	EZCSK-1350	134	82819	P-CARK-V48/1200-S/S PVECKS/S	81
82189	EZSB1200-1200C	129	82285	EZBMK-1200	134	82358	EZCSK-1350	136	82820	P-CARK-V54/1350-S/S PVECKS/S	81
82190	EZSB1350-1200C	129	82285	EZBMK-1200	136	82359	EZCSK-1500	130	82821	P-CARK-V60/1500-S/S PVECKS/S	81
82191	EZSB1500-1200C	129	82286	EZBMK-1350	134	82359	EZCSK-1500	132	82822	P-CARK-V72/1800-S/S PVECKS/S	81
82192	EZSB1800-1200C	129	82286	EZBMK-1350	136	82359	EZCSK-1500	134	82823	P-CARK-V60/1500-S/S PV2ECKSS	81
82193	EZSB600-1500C	129	82287	EZBMK-1500	134	82359	EZCSK-1500	136	82824	P-CARK2-V72/1800-S/S PV2ECKSS	81
82194	EZSB750-1500C	129	82287	EZBMK-1500	136	82360	EZCSK-1800	130	82825	P-CARK2-V84/2100-S/S PV2ECKSS	81
82195	EZSB900-1500C	129	82288	EZBMK-1800	134	82360	EZCSK-1800	132	82826	P-CARK2-V96/2400-S/S PV2ECKSS	81
82196	EZSB1050-1500C	129	82288	EZBMK-1800	136	82360	EZCSK-1800	134	82827	P-CARK2-V120/3000-S/S PV2ECKSS	81
82197	EZSB1200-1500C	129	82289	MPSTA-S/S	111	82360	EZCSK-1800	136	82828	R-CARK-V24/600-S/S RVECKS/S	88
82198	EZSB1350-1500C	129	82342	PTPK-MT-S/S	111	82361	EZBS-1200	134	82829	R-CARK-V30/750-S/S RVECKS/S	88
82199	EZSB1500-1500C	129	82343	PTPK-MT	110	82362	EZBS-1500	134	82830	R-CARK-V36/900-S/S RVECKS/S	88
82200	EZSB1800-1500C	129	82344	EZRMKM	130	82364	MESBK-PS	110	82831	R-CARK-V42/1050-S/S RVECKS/S	88
82201	EZSB600-1200I	131	82344	EZRMKM	132	82364	MESBK-PS	111	82832	R-CARK-V48/1200-S/S RVECKS/S	88
82202	EZSB750-1200I	131	82345	EZWPK-600	130	82393	SHIM-LDKIT	130			
82203	EZSB900-1200I	131	82345	EZWPK-600	132	82393	SHIM-LDKIT	132			
82204	EZSB1050-1200I	131	82345	EZWPK-600	134	82393	SHIM-LDKIT	134			
82205	EZSB1200-1200I	131	82345	EZWPK-600	136	82394	SHIM-MDKIT	136			
82206	EZSB1350-1200I	131	82346	EZWPK-750	130	82397	IBS-M1200	136			
82207	EZSB1500-1200I	131	82346	EZWPK-750	132	82398	IBS-M1500	136			
82208	EZSB1800-1200I	131	82346	EZWPK-750	134	82410	EZAI-600	129			
82209	EZSB600-1500I	131	82346	EZWPK-750	136	82411	EZAI-750	129			
82210	EZSB750-1500I	131	82347	EZWPK-900	130	82412	EZAI-900	129			
82211	EZSB900-1500I	131	82347	EZWPK-900	132	82413	EZAI-1050	129			
82212	EZSB1050-1500I	131	82347	EZWPK-900	134	82414	EZAI-1200	129			
82213	EZSB1200-1500I	131	82347	EZWPK-900	136	82415	EZAI-1350	129			
82214	EZSB1350-1500I	131	82348	EZWPK-1050	130	82416	EZAI-1500	129			
82215	EZSB1500-1500I	131	82348	EZWPK-1050	132	82417	EZAI-1800	129			
82216	EZSB1800-1500I	131	82348	EZWPK-1050	134	82689	USP18/450	110			

INDEX By Item Code

Item Code	Ordering Number	Page #	Item Code	Ordering Number	Page #	Item Code	Ordering Number	Page #	Item Code	Ordering Number	Page #
82833	R-CARK-V54/1350-S/S RVECKS/S	88	82892	MESPBL-SS	111	90181	MSTHD-W-S/S	69	91307	SKPU-8X3/8X50	168
82834	R-CARK-V60/1500-S/S RVECKS/S	88	82893	MUPSBK-SS	111	90182	MSTHD-S-S/S	69	91308	SKPU-8X5/8X50	168
82835	R-CARK-V72/1800-S/S RVECKS/S	88	82894	MESPKR-SS	111	90183	MSTHD-B-S/S	69	91309	SKPU-8X1X50	168
82836	R-CARK2-V60/1500-S/S RV2ECKSS	88	82895	MQMTSBK-SS	111	90184	MSTHD-G-S/S	69	91310	SKPU-10X3/8X25	168
82837	R-CARK2-V72/1800-S/S RV2ECKSS	88	82896	MUPSBK	110	90265	PTEZ-450	153	91311	SKPU-10X1/2X25	168
82838	R-CARK2-V84/2100-S/S RV2ECKSS	88	82897	UST-P-MT	110	90266	PTEZ-600	153	91312	SKPU-10X5/8X25	168
82839	R-CARK2-V96/2400-S/S RV2ECKSS	88	82898	UST-S-MT	110	90267	PTEZ-750	153	91313	SKPU-10X3/4X25	168
82840	R-CARK2-V120/3000-S/S RV2ECKSS	88	82899	UST-W-MT	110	90268	PTEZ-900	153	91314	SKPU-10X1X25	168
82841	MHS-CARK-V24/600-S/S MVECKS/S	95	82900	UST-G-MT	110	90269	PTEZ-1050	153	91315	SKPU-10X3/8X50	168
82841	MHS-CARK-V24/600-S/S MVECKS/S	102	82901	UST-P-MT-SS	111	90270	PTEZ-1200	153	91316	SKPU-10X1/2X50	168
82842	MHS-CARK-V30/750-S/S MVECKS/S	95	82902	UST-S-MT-SS	111	90283	SKPU-6X1/2X25	168	91317	SKPU-10X5/8X50	168
82842	MHS-CARK-V30/750-S/S MVECKS/S	102	82903	UST-W-MT-SS	111	90284	SKPU-6X3/4X25	168	91318	SKPU-10X3/4X50	168
82843	MHS-CARK-V36/900-S/S MVECKS/S	95	82904	UST-G-MT-SS	111	90285	SKPU-8X1/2X25	168	91319	SKPU-10X1X50	168
82843	MHS-CARK-V36/900-S/S MVECKS/S	102	82932	YTP-18/450	61	90286	SKPU-8X3/4X25	168	91320	SKPU-12X3/8X25	168
82844	MHS-CARK-V42/1050-S/S MVECKS/S	95	82933	YTP-24/600	61	90351	PTEZMB +A4431:D4439	153	91321	SKPU-12X1/2X25	168
82844	MHS-CARK-V42/1050-S/S MVECKS/S	102	82934	YTP-30/750	61	90352	PTEZPB	153	91322	SKPU-12X5/8X25	168
82845	MHS-CARK-V48/1200-S/S MVECKS/S	95	82935	YTP-36/900	61	90353	PTEZDC	153	91323	SKPU-12X3/4X25	168
82845	MHS-CARK-V48/1200-S/S MVECKS/S	102	82936	YTP-42/1050	61	90616	PTEZHD-1050	153	91324	SKPU-12X1X25	168
82846	MHS-CARK-V54/1350-S/S MVECKS/S	95	82937	YTP-48/1200	61	90617	PTEZHD-1200	153	91325	SKPU-12X3/8X50	168
82846	MHS-CARK-V54/1350-S/S MVECKS/S	102	82949	YTA-18/450	61	90618	PTEZHD-1350	153	91326	SKPU-12X1/2X50	168
82847	MHS-CARK-V60/1500-S/S MVECKS/S	95	82950	YTA-24/600	61	90619	PTEZHD-1500	153	91327	SKPU-12X5/8X50	168
82847	MHS-CARK-V60/1500-S/S MVECKS/S	102	82951	YTA-30/750	61	90620	PTEZHD-1800	153	91328	SKPU-12X3/4X50	168
82848	MHS-CARK-V72/1800-S/S MVECKS/S	95	82952	YTA-36/900	61	90621	PTEZHD-2100	153	91329	SKPU-12X1X50	168
82848	MHS-CARK-V72/1800-S/S MVECKS/S	102	82953	YTA-42/1050	61	90631	CRDF18	117	A1854	CBD-M-S/S	149
82849	MHS-CARK2-V60/1500-S/S MV2CKSS	95	82954	YTA-48/1200	61	90632	CRDF24	117	A1856	CBD-L-S/S	149
82849	MHS-CARK2-V60/1500-S/S MV2CKSS	102	83099	YTCHD-900	57	90633	CRDF30	117	A0012	WCB	121
82850	MHS-CARK2-V72/1800-S/S MV2CKSS	95	83100	YTCHD-1050	57	90634	CRDF36	117	A0012	WCB	122
82850	MHS-CARK2-V72/1800-S/S MV2CKSS	102	83101	YTCHD-1200	57	90635	CRDF42	117	A0151	HBP2600-PL-TP	148
82851	MHS-CARK2-V84/2100-S/S MV2CKSS	95	83102	YTCHD-1350	57	90636	CRDF48	117	A0223	BP450-HD-B	144
82851	MHS-CARK2-V84/2100-S/S MV2CKSS	102	83103	YTCHD-1500	57	90637	CRDF54	117	A0224	BP600-HD-B	144
82852	MHS-CARK2-V96/2400-S/S MV2CKSS	95	83105	YTCHD-1800	57	90638	CRDF60	117	A0235	PTMSR	163
82852	MHS-CARK2-V96/2400-S/S MV2CKSS	102	83106	YTPHD-36/900	62	90641	CBC3R	117	A0316	SB1200A	121
82853	MHS-CARK2-V120/3000-S/S MV2CKS	95	83107	YTPHD-42/1050	62	90795	PTEZHD-1500	153	A0407	SB750A	121
82853	MHS-CARK2-V120/3000-S/S MV2CKS	102	83108	YTPHD-48/1200	62	90796	PTEZHD-1600	153	A0435	SB1050A	121
82876	P-CARK2-V78/1950-S/S PV2ECKSS	81	83109	YTPHD-54/1350	62	90797	PTEZHD-2000	153	A0612	BP800-1050MF-S/S MAIN FRAME	144
82887	UHSPK-M	110	83110	YTPHD-60/1500	62	90798	HDPTZUG-1050	153	A0613	BP800-1050-PL-S/S	144
82888	USPK-SS-M	111	83112	YTPHD-72/1800	62	90799	HDPTZUG-1200	153	A0614	BP-LA-S/S	144
82889	UHSPK-SS-M	111	83120	YTHD-900S	57	90800	HDPTZUG-1350	153	A0615	BP-MB-S/S	144
82890	UMBK-M	110	83121	YTHD-1050S	57	90801	HDPTZUG-1500	153	A0616	BP-SC-S/S	144
82891	UMBK-SS-M	111	83122	YTHD-1200S	57	90802	HDPTZUG-1800	153	A0617	BP-TL-S/S	144
			83123	YTHD-1350S	57	90803	PTEZHDB-2	153	A0620	BP1200-1400MF-S/S MAIN FRAME	144
			83124	YTHD-1500S	57	90804	PTEZHDPB-2	153	A0621	BP1200-1400-PL-S/S	144
			83126	YTHD-1800S	57	90805	PTEZHDDC-2	153	A0646	BP1500-1600MF-S/S MAIN FRAME	144
			83134	YTHD-TC-900S	57	90806	PTEZHDPB-2	153	A0647	BP1500-1600-PL-S/S	144
			83135	YTHD-TC-1050S	57	90807	PTEZHDBB-2	153	A0682	BP450-750MF-S/S MAIN FRAME	144
			83136	YTHD-TC-1200S	57	91222	SKPU-6X1/2X50	168	A0683	BP450-750-PL-S/S	144
			83137	YTHD-TC-1350S	57	91223	SKPU-6X3/4X50	168	A0887	SB600A	121
			83138	YTHD-TC-1500S	57	91224	SKPU-8X1/2X50	168	A0912	SB900A	121
			83140	YTHD-TC-1800S	57	91225	SKPU-8X3/4X50	168	A1155	HBP-MB-TP-S/S	146
			83223	YTC-450	56	91288	SKPU-4X3/8X25	168	A1155	HBP-MB-TP-S/S	148
			83224	YTC-600	56	91289	SKPU-4X1/2X25	168	A1357	SB1800A	121
			83225	YTC-750	56	91290	SKPU-4X5/8X25	168	A1436	FLSC2000-S/S	166
			83226	YTC-900	56	91291	SKPU-4X3/4X25	168	A1437	FLSC-TP-S/S	166
			83227	YTC-1050	56	91292	SKPU-4X1X25	168	A1438	FLSC-CP-S/S	166
			83228	YTC-1200	56	91293	SKPU-4X3/8X50	168	A1439	FLSC2000-CB-S/S	166
			83229	YT-450S	56	91294	SKPU-4X1/2X50	168	A1440	FLSC2000-MC-S/S	166
			83230	YT-600S	56	91295	SKPU-4X5/8X50	168	A1546	BP1800MF-S/S MAIN FRAME	144
			83231	YT-750S	56	91296	SKPU-4X3/4X50	168	A1547	BP1800-PL-S/S	144
			83232	YT-900S	56	91297	SKPU-4X1X50	168	A1575	RPHD1800-S/S	66
			83233	YT-1050S	56	91298	SKPU-6X3/8X25	168	A1588	HXFHD1800M-S/S	37
			83234	YT-1200S	56	91299	SKPU-6X5/8X25	168	A1589	HXFHD1800L-S/S	37
			83241	YT-TC-450S	56	91300	SKPU-6X1X25	168	A1590	HXFHD2100M-S/S	37
			83242	YT-TC-600S	56	91301	SKPU-6X3/8X50	168	A1591	HXFHD2100L-S/S	37
			83243	YT-TC-750S	56	91302	SKPU-6X5/8X50	168	A1592	HXFHD2400M-S/S	37
			83244	YT-TC-900S	56	91303	SKPU-6X1X50	168			
			83245	YT-TC-1050S	56	91304	SKPU-8X3/8X25	168			
			83246	YT-TC-1200S	56	91305	SKPU-8X5/8X25	168			
			87895	MESPBL	110	91306	SKPU-8X1X25	168			

INDEX By Item Code

Item Code	Ordering Number	Page #	Item Code	Ordering Number	Page #	Item Code	Ordering Number	Page #	Item Code	Ordering Number	Page #
A1593	HXFHD2400L-S/S	37	A2304	HBP2500-PL-TP	146	A2501	HBP2400-PL-TP-S/S	148	PTM-1050-3		163
A1594	HVHD1800M-S/S	39	A2304	HBP2500-PL-TP	148	A2502	HBP2500-PL-TP-S/S	146	PTM-1050-3-S/S		164
A1595	HVHD1800L-S/S	39	A2305	HBP900-MF-TP	146	A2502	HBP2500-PL-TP-S/S	148	PTM-1200-1		163
A1596	HVHD1800LL-S/S	39	A2306	HBP1050-MF-TP	146	A2504	HBP900-MF-TP-S/S	146	PTM-1200-1-S/S		164
A1597	HVHD2100M-S/S	39	A2307	HBP1200-MF-TP	146	A2505	HBP1050-MF-TP-S/S	146	PTM-1200-2		163
A1598	HVHD2100L-S/S	39	A2308	HBP1400-MF-TP	146	A2506	HBP1200-MF-TP-S/S	146	PTM-1200-2-S/S		164
A1599	HVHD2100LL-S/S	39	A2309	HBP1500-MF-TP	146	A2507	HBP1400-MF-TP-S/S	146	PTM-1200-3		163
A1600	HVHD2400M-S/S	39	A2310	HBP1600-MF-TP	146	A2508	HBP1500-MF-TP-S/S	146	PTM-1200-3-S/S		164
A1601	HVHD2400L-S/S	39	A2311	HBP1800-MF-TP	146	A2509	HBP1600-MF-TP-S/S	146	PTM-1350-1		163
A1602	HVHD2400LL-S/S	39	A2312	HBP2000-MF-TP	146	A2510	HBP1800-MF-TP-S/S	146	PTM-1350-1-S/S		164
A1603	PVHD1800-S/S	63	A2313	HBP2400-MF-TP	146	A2511	HBP2000-MF-TP-S/S	146	PTM-1350-2		163
A1604	PVHD2100-S/S	63	A2314	HBP2200-MF-TP	146	A2512	HBP2200-MF-TP-S/S	146	PTM-1350-2-S/S		164
A1605	PVHD2400-S/S	63	A2315	HBP2500-MF-TP	146	A2513	HBP2400-MF-TP-S/S	146	PTM-1350-3		163
A1610	RVHD2400-S/S	65	A2316	HBP900-B-TP	146	A2514	HBP2500-MF-TP-S/S	146	PTM-1350-3-S/S		164
A1613	PPHD2100-S/S	64	A2317	HBP1050-B-TP	146	A2515	HBP-LA-TP-S/S	146	PTM-1500-1		163
A1620	SB1400A	121	A2318	HBP1200-B-TP	146	A2518	HDSTKD	42	PTM-1500-2		163
A1622	RBPRET	152	A2319	HBP1400-B-TP	146	A2519	HDSTKD-S/S	42	PTM-1500-3		163
A1626	RVHD1800-S/S	65	A2320	HBP1500-B-TP	146	A2527	RPHD2100	66	PTM-1600-1		163
A1628	RVHD2100-S/S	65	A2321	HBP1600-B-TP	146	A2590	HPHD2400-S/S	42	PTM-1600-1-S/S		164
A1629	RPHD2100-S/S	66	A2322	HBP1800-B-TP	146	A2596	FLSCM-CP-S/S	166	PTM-1600-2		163
A1775	PPHD2400-S/S	64	A2323	HBP2000-B-TP	146	A2629	CBD-ST-TB-S/S	150	PTM-1600-2-S/S		164
A1781	PPHD1800-S/S	64	A2324	HBP2400-B-TP	146	A2671	UNB73	42	PTM-1600-3		163
A1783	HPHD2000-S/S	42	A2325	HBP2200-B-TP	146	A2704	RMC2-AP-S/S	167	PTM-1600-3-S/S		164
A1784	CBD-ST-XL-FR-B	150	A2326	HBP2500-B-TP	146	A2803	PPHD2100	64	PTM-1800-1		163
A1838	SB1500A	121	A2330	HBP-LA-TP	146	A2825	CRDLBLK-RH-S/S	85	PTM-1800-1-S/S		164
A1996	BP2000MF	144	A2396	HVHD2600M	38	A2825	CRDLBLK-RH-S/S	92	PTM-1800-2		163
A2046	PVHD2000-S/S	63	A2397	HVHD2600LL	38	A2825	CRDLBLK-RH-S/S	105	PTM-1800-2-S/S		164
A2063	HPHD1800-S/S	42	A2449	CBD-ST-PB	150	A2826	CRDLBLK-LH-S/S	85	PTM-1800-3		163
A2120	PPHD2000-S/S	64	A2461	HVHD2600L	38	A2826	CRDLBLK-LH-S/S	92	PTM-1800-3-S/S		164
A2138	CBD-ST-XL-S/S	150	A2462	HVHD2600M-S/S	39	A2826	CRDLBLK-LH-S/S	105	PTM-2000-1		163
A2189	HBP-SC-TP-S/S	146	A2463	HVHD2600L-S/S	39	A2829	MR-1500PG	123	PTM-2000-1-S/S		164
A2189	HDSTCK-S/S	42	A2464	HVHD2600LL-S/S	39	A2830	MR-1600PG	123	PTM-2000-2		163
A2215	CBD-ST-CS-S/S	150	A2465	HVHD3000M-S/S	39	A2831	MR-1800PG	123	PTM-2000-2-S/S		164
A2218	CBD-ST-L-FR-B	150	A2466	HVHD3000L-S/S	39	A2832	MR-2100PG	123	PTM-2000-3		163
A2237	BP750-HD-B	144	A2467	HVHD3000LL-S/S	39	A2833	MR-2400PG	123	PTM-2000-3-S/S		164
A2283	HBP900-TP	145	A2474	HBP-TP-900 S/S	145	A2834	MR-2600PG	123	PTM-2400-1		163
A2284	HBP1050-TP	145	A2475	HBP-TP-1050 S/S	145	A2835	MR-3000PG	123	PTM-2400-1-S/S		164
A2285	HBP1200-TP	145	A2476	HBP-TP-1200 S/S	145	A2836	MR-450PG	123	PTM-2400-2		163
A2286	HBP1400-TP	145	A2477	HBP-TP-1400 S/S	145	A2837	MR-600PG	123	PTM-2400-2-S/S		164
A2287	HBP1500-TP	145	A2478	HBP-TP-1500 S/S	145	A2838	MR-750PG	123	PTM-2400-3		163
A2288	HBP1600-TP	145	A2479	HBP-TP-1600 S/S	145	A2839	MR-900PG	123	PTM-2400-3-S/S		164
A2289	HBP1800-TP	145	A2480	HBP-TP-1800 S/S	145	A2840	MR-1050PG	123	PTM-2600-1		163
A2290	HBP2000-TP	145	A2481	HBP-TP-2000 S/S	145	A2841	MR-1200PG	123	PTM-2600-1-S/S		164
A2291	HBP2200-TP	145	A2482	HBP-TP-2200 S/S	145	A2842	SMR-CCB-L73	83	PTM-2600-2		163
A2292	HBP2400-TP	145	A2483	HBP-TP-2400 S/S	145	A2842	SMR-CCB-L73	90	PTM-2600-2-S/S		164
A2293	HBP2500-TP	145	A2484	HBP-TP-2500 S/S	145	A2842	SMR-CCB-L73	103	PTM-2600-3		163
A2294	HBP900-PL-TP	146	A2492	HBP900-PL-TP-S/S	146	A2842	SMR-CCB-L73	123	PTM-2600-3-S/S		164
A2294	HBP900-PL-TP	148	A2492	HBP900-PL-TP-S/S	148	A2843	SMR-CCB-R73	83	PTM-3000-1		163
A2295	HBP1050-PL-TP	146	A2493	HBP1050-PL-TP-S/S	146	A2843	SMR-CCB-R73	90	PTM-3000-1-S/S		164
A2295	HBP1050-PL-TP	148	A2493	HBP1050-PL-TP-S/S	148	A2843	SMR-CCB-R73	103	PTM-3000-2		163
A2296	HBP1200-PL-TP	146	A2494	HBP1200-PL-TP-S/S	146	A2843	SMR-CCB-R73	123	PTM-3000-2-S/S		164
A2296	HBP1200-PL-TP	148	A2494	HBP1200-PL-TP-S/S	148	A2844	SMR-CCB-L60	123	PTM-3000-3		163
A2297	HBP1400-PL-TP	146	A2495	HBP1400-PL-TP-S/S	146	A2845	SMR-CCB-R60	123	PTM-3000-3-S/S		164
A2297	HBP1400-PL-TP	148	A2495	HBP1400-PL-TP-S/S	148	A2988	EZP1P24-S/S	18	PTM-750-1		163
A2298	HBP1500-PL-TP	146	A2496	HBP1500-PL-TP-S/S	146	A3041	EZP1P30-S/S	18	PTM-750-1-S/S		164
A2298	HBP1500-PL-TP	148	A2496	HBP1500-PL-TP-S/S	148	A3119	EZP1P36-S/S	18	PTM-750-2		163
A2299	HBP1600-PL-TP	146	A2497	HBP1600-PL-TP-S/S	146	B0092	CBD-ST-MC	150	PTM-750-2-S/S		164
A2299	HBP1600-PL-TP	148	A2497	HBP1600-PL-TP-S/S	148	G1211	HEX NUT	55	PTM-750-3		163
A2300	HBP1800-PL-TP	146	A2498	HBP1800-PL-TP-S/S	146	G1211	HEX NUT	72	PTM-750-3-S/S		164
A2300	HBP1800-PL-TP	148	A2498	HBP1800-PL-TP-S/S	148	G1211	HEX NUT	77	PTM-900-1		163
A2301	HBP2000-PL-TP	146	A2499	HBP2000-PL-TP-S/S	146	G1211	HEX NUT	97	PTM-900-1-S/S		164
A2301	HBP2000-PL-TP	148	A2499	HBP2000-PL-TP-S/S	148		PTM-1050-1	163	PTM-900-2		163
A2302	HBP2400-PL-TP	146	A2500	HBP2200-PL-TP-S/S	146		PTM-1050-1-S/S	164	PTM-900-2-S/S		164
A2302	HBP2400-PL-TP	148	A2500	HBP2200-PL-TP-S/S	148		PTM-1050-2	163	PTM-900-3		163
A2303	HBP2200-PL-TP	146	A2501	HBP2400-PL-TP-S/S	146		PTM-1050-2-S/S	164	PTM-900-3-S/S		164
A2303	HBP2200-PL-TP	148									



Partners in Productivity

10 Solent Circuit

Baulkham Hills NSW 2153

Phone: +61 2-8818-2000 Fax: +61 2-8824-6333

Toll Free: 1300 098 435

E-mail: salesau@flexco.com

www.flexco.com