

# USE AND CARE GUIDE

---

## 15 INCH LED OUTDOOR LANTERN

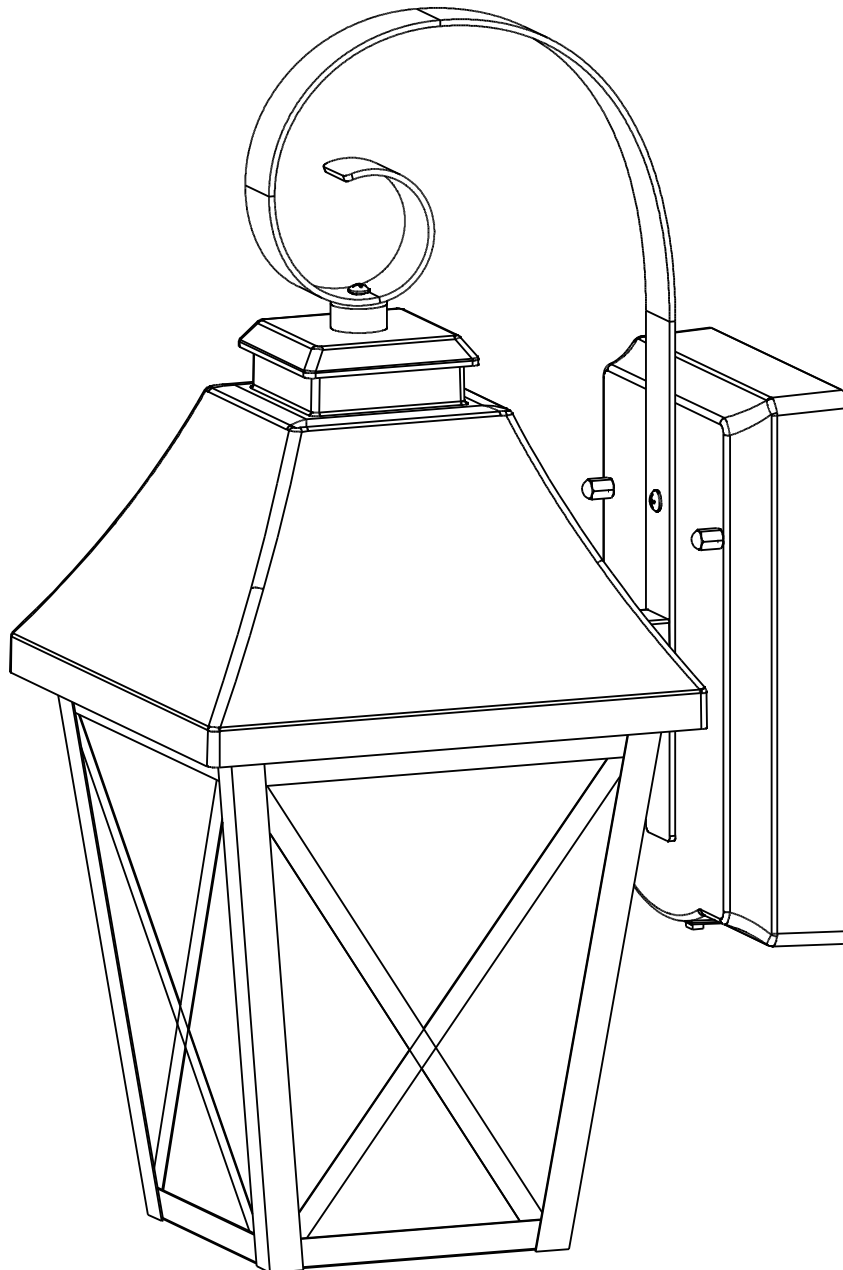

# Table of Contents

Table of Contents ..... 2  
Safety Information ..... 2  
Warranty ..... 2  
Pre-Installation ..... 3  
    Tools Required ..... 3  
    Hardware Included ..... 3  
Installation ..... 4-5  
Color Changing Instructions ..... 6

# Safety Information

## For your safety, always remember to:

- Turn off the power supply at the fuse or circuit breaker box before you install the fixture.
- Ground the fixture to avoid potential electric shock and to ensure reliable starting.
- Double-check all connections to be sure they are tight and correct.
- Wear rubber soled shoes and work on a sturdy wooden ladder.
- Account for small parts and destroy packing material, as these may be hazardous to children.

This fixture is designed for use in a circuit protected by a fuse or circuit breaker. It is also designed to be installed in accordance with local electrical codes. If you are unsure about your wiring, check your local electrical code or consult a qualified electrician.

 **WARNING: RISK OF SHOCK.** House electric current can cause painful shock or serious injury unless handled properly.

 **CAUTION:** Turn off the main power at the circuit breaker before installing the fixture, in order to prevent possible shock.

**NOTICE:** All electrical connections must be in accordance with local and national standards, National Electric Code (N.E.C.) in the US and Canadian Electrical Code (C.E.C.) in Canada. If you are unfamiliar with proper electrical wiring connections obtain the services of a qualified electrician.  
Remove the fixture and the mounting package from the box and make sure that no parts are missing by referencing the illustrations on the installation instructions.

## FCC STATEMENT

This device complies with part 15 of the FCC Rules. Operation is subject to the following two conditions:

(1) This device may not cause harmful interference, and (2) this device must accept any interference received, including interference that may cause undesired operation.  
Note: This equipment has been tested and found to comply with the limits for a Class B digital device, pursuant to part 15 of the FCC Rules. These limits are designed to provide reasonable protection against harmful interference in a residential installation. This equipment generates, uses and can radiate radio frequency energy and, if not installed and used in accordance with the instructions, may cause harmful interference to radio communications. However, there is no guarantee that interference will not occur in a particular installation. If this equipment does cause harmful interference to radio or television reception, which can be determined by turning the equipment off and on, the user is encouraged to try to correct the interference by one or more of the following measures: Reorient or relocate the receiving antenna. Increase the separation between the equipment and receiver. Connect the equipment into an outlet on a circuit different from that to which the receiver is connected. Consult the dealer or an experienced radio/TV technician for help. Any changes or modifications not expressly approved by the manufacturer could void the user's authority to operate the equipment.  
Feit Electric Company, 4901 Gregg Road, Pico Rivera, CA 90660. [www.feit.com](http://www.feit.com).

# Limited Warranty

This product is warranted to be free from defects in workmanship and materials for up to 5 years from date of purchase. If the product fails within the warranty period, please contact Feit Electric at [info@feit.com](mailto:info@feit.com), visit [feit.com/contact-us](http://feit.com/contact-us) or call 1-866-326-BULB (2852) for instructions on replacement or refund. **REPLACEMENT OR REFUND IS YOUR SOLE REMEDY. EXCEPT TO THE EXTENT PROHIBITED BY APPLICABLE LAW, ANY IMPLIED WARRANTIES ARE LIMITED IN DURATION TO THE DURATION OF THIS WARRANTY. LIABILITY FOR INCIDENTAL OR CONSEQUENTIAL DAMAGES IS HEREBY EXPRESSLY EXCLUDED.** Some states and provinces do not allow the exclusion of incidental or consequential damages, so the above limitation or exclusion may not apply to you. This warranty gives you specific legal rights, and you may also have other rights which vary from state to state or province to province.

# Pre-Installation

## TOOLS REQUIRED

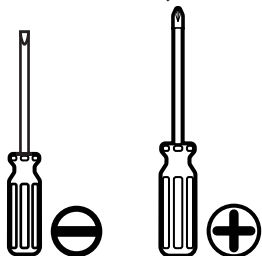

## HARDWARE INCLUDED

 **NOTE:** Hardware not shown to actual size.

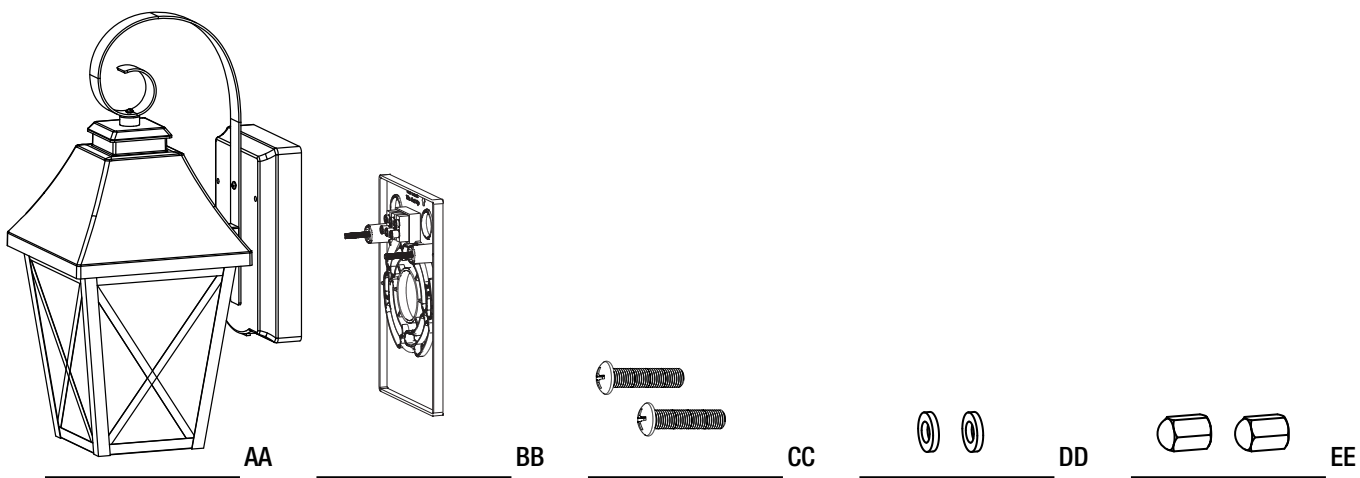

Part	Description	Quantity
AA	Fixture	1
BB	Mounting Plate	1
CC	Junction Box Screws	2
DD	Washers	2
EE	Decorative Nuts	2

# Installation

## 1 Turning off the power

- Turn the power OFF at the switch and fusebox or the circuit breaker.

## 2 Removing the mounting plate

- Unscrew the Decorative Nuts (DD), remove the Washers (EE) and keep them for Step 7.
- Remove the Mounting Plate (BB).

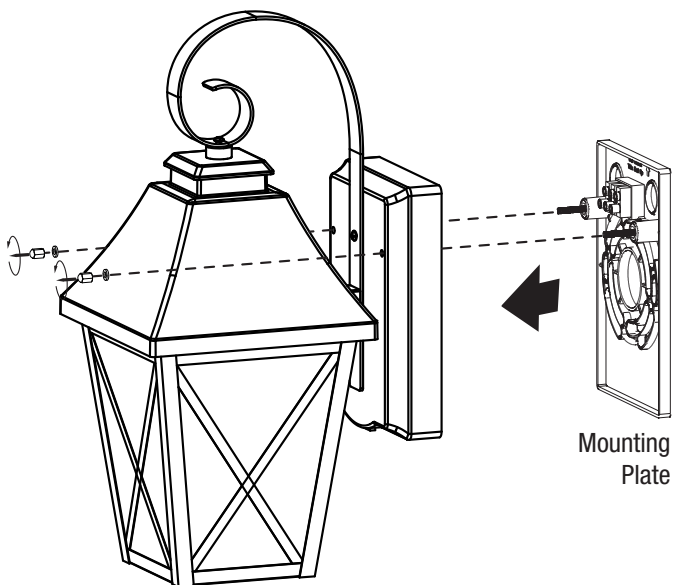

## 4 Installing the mounting plate

- Attach the Mounting Plate (BB) to the outlet box using the provided Junction Box Screws (CC).
- Make sure to run the house wires through the center hole on the Mounting Plate (BB).

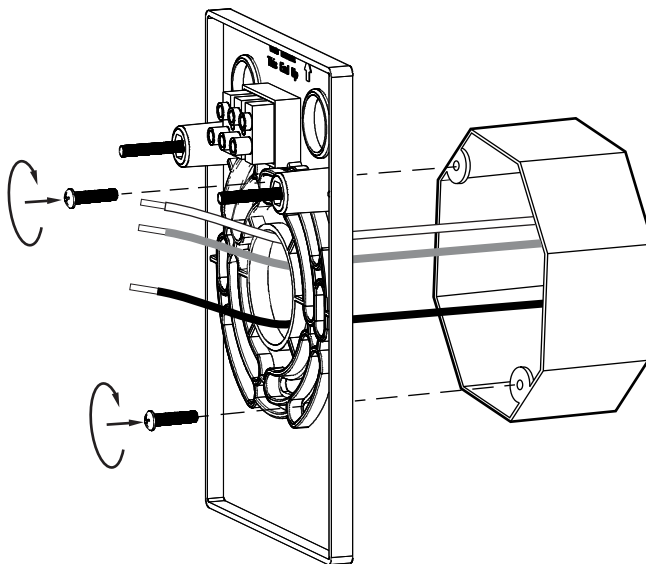

## 3 Identifying the wires

- Identify the wires at the junction box.
- (Black-line voltage, White-neutral, Green-ground).
- Make them accessible for easy connection.

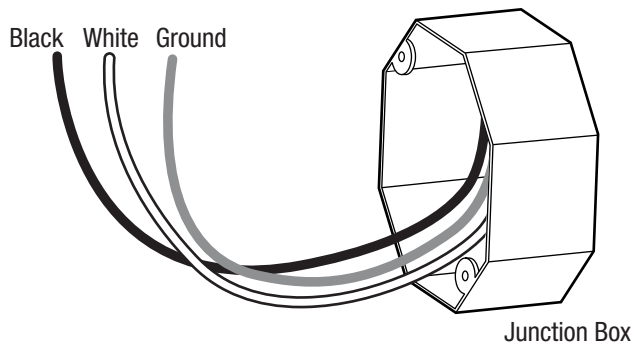

## 5 Connecting the wires

- Connect the house wires directly to the terminal block.
- Tighten the screws on the terminal block using a screw driver to secure the wire connections. See below

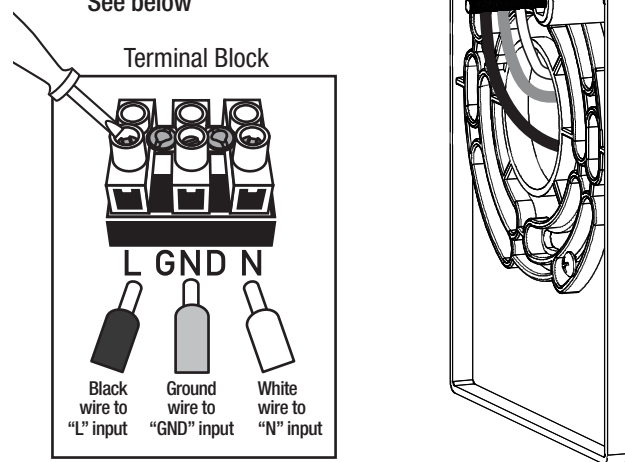

## Installation (continued)

### 6 Installing the fixture

- Gently align the quick-connect pins to the top holes on the terminal block.
- Make sure the screws on the Mounting Plate (BB) are also aligned.
- Push the fixture back plate to the Mounting Plate (BB). Make sure that the threaded screw ends are coming out through the front side of the fixture back plate.

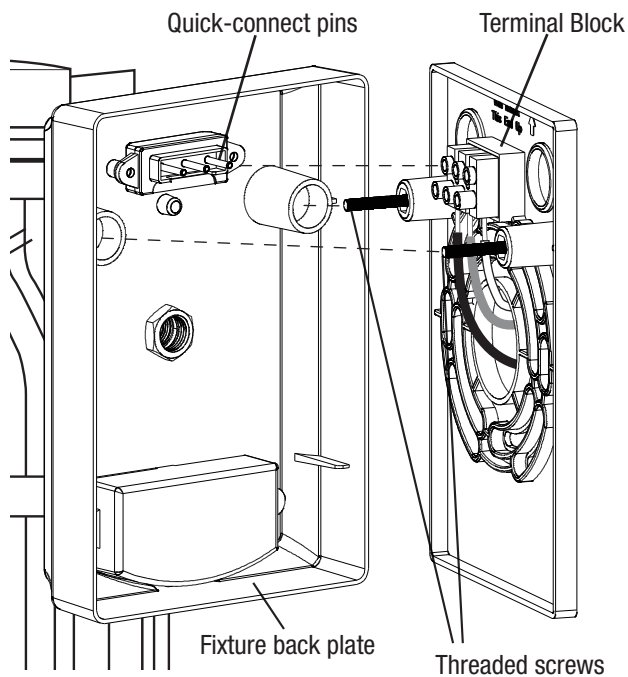

### 7 Securing the fixture

- Install the rubber washers (DD) and secure the fixture to the Mounting Plate by tightening decorative nuts (EE).

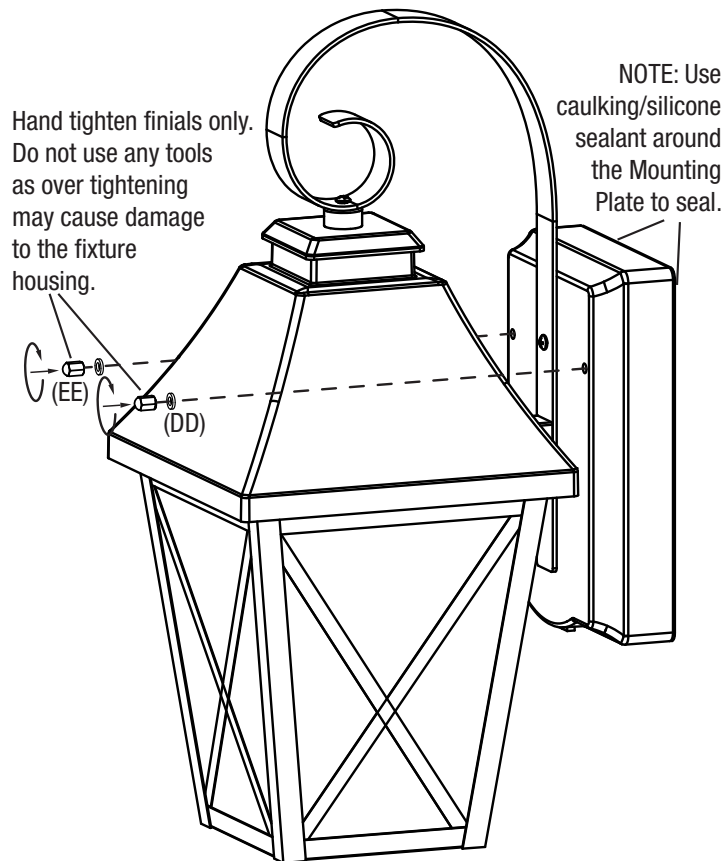

### 8 Turning the power on

- Turn the power on at the circuit breaker or replace fuse.

# Mode Changing Instructions

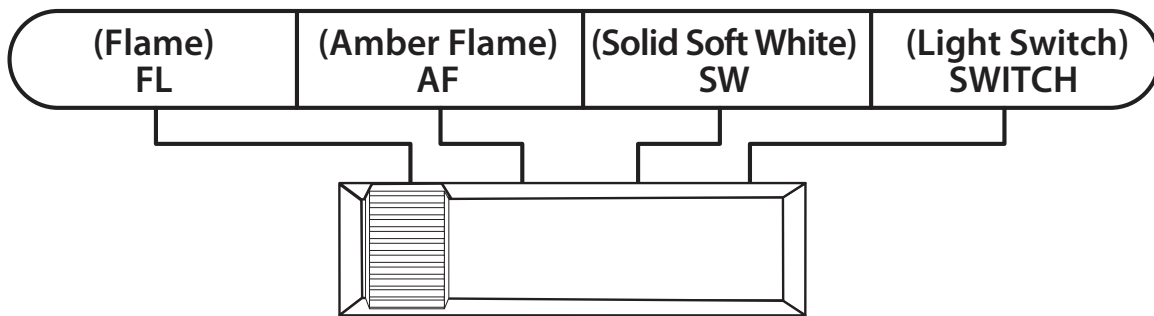

- You can lock in one color temperature or change among multiple color temperatures. It will memorize the last color temperature, and reset automatically.
- Flame - Amber Flame - Solid Soft White - Light Switch  
Marks on the lamp: FL-AF-SW-Switch
- When the slide switch is set to FL (Flame), the color temperature fixes at 1800K.
- When the slide switch is set to AF (Amber Flame), the color temperature fixes at 2000K.
- When the slide switch is set to SW (Solid Soft White), the color temperature fixes at 2700K.
- When the slide switch is set to SWITCH, the color temperature can be changed from FL-AF-SW with your existing light switch.
- To change color temperatures using your existing light switch:
  - Set the slide switch on the back of the fixture to “SWITCH”.
  - Toggle your light switch ON and OFF within 0.5-3 seconds to cycle through the three different color temperatures.
  - If the fixture is left ON for over 10 seconds then turned OFF, the fixture will remember the last color temperature selected and will display that color when turned on again.

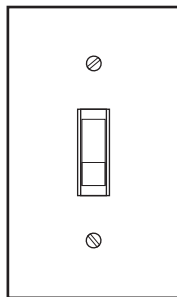





Contact Feit Electric at [info@feit.com](mailto:info@feit.com) or call

**1-800-543-3348**

7 a.m. - 5 p.m., PCT, Monday - Friday  
for instructions on replacement.

Do not return the product to the store.

**FEITELECTRIC.COM**

Retain this manual for future use.